

Beverly Hills
Bookbinding Service
(310) 378-0728

THE
PHOTOGRAPHIC NEWS:

A WEEKLY RECORD

OF THE

PROGRESS OF PHOTOGRAPHY.

VOLUME VII.

EDITED BY G. WHARTON SIMPSON.

Nulla recordanti lux est ingrata.—MARTIAL.

LONDON:
PRINTED AND PUBLISHED BY THOMAS PIPER, 32, PATERNOSTER ROW.

1863.

THE HISTORY OF THE

ROYAL SOCIETY

LONDON:

THOMAS PIPER, PRINTER, 32, PATERNOSTER ROW.



P R E F A C E .

At the close of a volume we are permitted in a preface, or, to speak exactly, in a few after-words, to address our readers in a more direct and personal manner than on other occasions; in a manner somewhat similar to that of a Parliamentary representative, who meets his constituency at the close of a session, to review briefly his labours in the past, and renew his pledges for the future.

A glance through the pages of the volume we have just completed is suggestive of some very pleasant thoughts, as to the present position and future prospects of the Art of Photography. At no former period has its practice been so wide-spread, or its results so perfect; no former period has witnessed so much mental activity amongst its devotees, or so much commercial success amongst its professors generally; at no period has the PHOTOGRAPHIC NEWS been in communication with so large a circle of correspondents, or addressed such a numerous body of readers. Photographic journalism has indeed borne a singular position, in being so essentially a cause and a consequence of photographic progress. It is in no spirit of self-laudation, but simply for the purpose of mentioning a noteworthy fact, we make the remark, that in its literature Photography occupies a position unparalleled by any of the older Arts and Sciences. We know of no branch of Science or Art which has been or is so largely represented, which has its every fact and phase so completely recorded as Photography; of no exclusive or technical literature which has been so readily appreciated and freely encouraged as that of Photography.

We feel at once pride, pleasure, and encouragement in recognizing and contemplating these facts. We feel it a privilege to conduct a Journal for a circle of readers so enthusiastic and so appreciative. But we also feel a great responsibility. With each accession of readers—and during the year we have had many hundreds of accessions—we feel that responsibility is increased.

In the volume now in the hands of our readers, we have aimed primarily to present a perfect record of the year's Photographic Progress, in every quarter of the world: a record of scientific good results. Mr. Spiller's important discovery of free nitrate in the whites of finished glass plates; Cooper's experiments with resinized paper; the probable, to the diminished use of bromide, have discovered or confirmed; whatever artists have achieved; and, in our conviction, thus to be made clear; whatever new scope or fresh applications commercial photography has unfolded; whatever, in short, has conduced to the advancement of the Art, or the advantage of all classes of its adherents, we have endeavoured to chronicle with exactitude and fulness. Our second aim has been to aid the progress we have recorded, both by initiating improvements and giving impetus to those commenced by others. To this end we have been aided by a staff of contributors which has included some of the most able writers, skilled experimentalists, profound chemists, and accomplished photographers and artists who have been associated with the Art. To this end we have been aided by a highly intelligent and liberal circle of correspondents, to whose hints and suggestions our readers are largely indebted. And to this end our own energies, by constant experiment, observation, and research, have been entirely devoted.

We have the satisfaction of believing that we have not entirely failed in our aims. The encouraging communications we receive, and the rapidly increasing circle of readers we address, afford the best evidence that we have to no small extent succeeded in our efforts; and we here take occasion to offer our hearty and appreciative thanks to contributors and correspondents for their valued sympathy and aid.

So much for the past. For the future we need not many words: we prefer to be judged by merit rather than promise, by results rather than pledges. Wherein we have done well we will continue in well-doing. Wherein we can do better, we shall omit no opportunity or occasion of improvement which may be conducive to the interests or pleasure of our readers. The continued expansion of the art involves ever fresh demands upon its representative literature. We shall always endeavour to meet these demands. And whilst we shall hope to maintain for the PHOTOGRAPHIC NEWS the position of the guide and referee of the student; the registrar and text-book of the scientific experimenter; the counsellor and encourager of the artist and operator, we shall endeavour also to meet the requirements of the art in its rapidly widening applications as an important branch of Industry. In short, whatever relates to the advancement of the position of Photography as an art, a science, or a profession, we shall endeavour to uphold, and to worthily sustain the position of the exponent of Photography and representative of Photographers.

We conclude by wishing our readers a Merry Christmas and a Happy New Year.

THE PHOTOGRAPHIC NEWS.

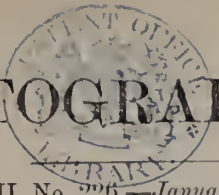

Vol. VII. No. 226.—January 2, 1863.

PHOTOGRAPHY DURING THE PAST YEAR.

ANOTHER year of steady improvement has passed. No great or specific change in the general practice of the art, no great discovery or invention, has been added to the record. The year has, nevertheless, been one of decided activity and success.

At the commencement of the year the advent of the International Exhibition, and the position of photography therein, was a topic of all-absorbing interest. The Exhibition has come and gone, but its influence on photography has been comparatively unimportant. The relations between the two commenced with misunderstanding, and ended without satisfaction. It is true that in this Exhibition photography for the first time received definite recognition as a distinct and independent art; and it is true that it fully maintained, by the excellence of the various contributions and variety of its applications, its claim to such a position. In one point alone, so far as photography and photographers themselves are concerned, did the contributions come short of what might have been hoped and anticipated. We refer to the question of permanency. Many prints which were subjected to the influences of damp walls, and some which were not, faded very palpably, even whilst hanging in the Exhibition. That some prints, even when hung on the same walls, did not fade, proves, however, that none need have done so if the conditions of permanency were well understood and carefully observed.

Printing, without doubt, still continues to be the chief photographic difficulty. Processes for the production of negatives by different methods continue to improve, and little seems left to desire in this respect; but printing still progresses with slow and uncertain steps. It is true that, in skilful hands, despite the difficulties arising from imperfect knowledge and bad paper, very beautiful prints are produced. Still very little is understood of the *rationale* of the process, and very little certainty exists as to the permanency of the results. The attention which the subject has excited during the year it is probable may lead to some good results. Mr. Spiller's important discovery of the presence of free nitrate in the whites of finished prints, and Mr. Cooper's experiments with resinized paper, will tend, it is probable, to the diminished use of albumenized paper; and, in our conviction, thus to the removal of one of the causes of fading.

Setting aside the question of permanency, no branch of the art has been the subject of greater trouble and anxiety, even to skilled photographers, than the method of producing fine and brilliant prints; but the various researches and suggestions of the year have, we believe, contributed largely to reduce these difficulties. If all the causes of meanness or want of brilliancy are not well understood, at least the means of overcoming such difficulties are more familiar. The use of an ammonia-nitrate bath for albumenized paper has been found in many hands of immense value in this respect. Fuming the excited paper before printing is stated to have been found in the United States to give excellent results. The use of a bath of acetate of soda prior to toning has been found useful by many, and in others the perfect washing and soaking of the film of albumen, prior to immersion in the toning solution, has been found effectual in preventing meanness. In all cases the use of toning baths, mixed long enough to have attained maturity, and moderately slow toning, have been found of the utmost value. The efficiency

of various remedies indicates the fact that various causes for evil exist. A common opinion has prevailed to the effect that to the bad quality of the paper most of the causes might be traced. Mr. Sutton has proposed, by rendering the paper itself waterproof, to confine the image solely to the film of albumen on its surface. The same idea, in modified forms, has been proposed before, but not extensively carried out. From what we have seen of the results of the new suggestion, we hope much. But we shall see.

Associated with the question of permanent printing is the subject of photo-lithography, which has excited much interest during the year. For the purposes of reproduction of all subjects in which gradation is secured by artificial means, such as stippling or hatching, the processes of Col. James, Mr. Osborne, and others, seem to have attained perfection. The attention of the two gentlemen we have named has been almost solely confined to the reproduction of maps and similar subjects, and not to the securing of half tone. Recently Col. James has given some attention to that part of the question, and has favoured us with some examples which are full of promise. More recently we have been favoured with the examination of some specimens by the process of M. Asser, amongst which are by far the finest specimens of half tone we have seen.

The year has been prolific in modified dry processes. The tannin process has maintained its ground, or increased its popularity. Mr. England's modification, by the addition of honey, has proved very successful in many hands. Wet development and alkaline development have aided materially in shortening exposures with these plates, and, in some cases, in permitting the production of instantaneous pictures. Neither method of development is yet sufficiently well understood to give certainty to the processes, but the results of both are sufficient to indicate the fact that rapidity depends upon development as much or more than upon the preparation of the plate. The value of a full proportion of bromide in dry plates has been well-established on all hands. Mr. Sutton has proposed equal parts of bromine and iodine, as an imperative condition for rapid results. Mr. Keene has long prepared collodion for dry plates with such proportions, and, in his recently published interesting investigations in rapid dry photography, has had opportunity of fully confirming its value. Mr. Bartholomew has also added some valuable suggestions for dry plate photography, which have not been very extensively carried out, but have been nevertheless very successful. Messrs. Hislop, Ward, Window, and others, have offered valuable hints on the simplest of all dry processes—simply washed collodion, without preservation. In these hands plates thus prepared have been very successful. As to the simplicity and value of such a process, there cannot be two opinions.

We have reason to believe that, in portraiture at least, this year has been one of very great commercial success, especially amongst skilful photographers. We are glad to believe that a process of purgation has to some extent been going forward. What have been termed "Photographic Dens" have become more scarce, and able photographers more plentiful and successful. We have heard, with much satisfaction, of a large number of instances in which the number of portraits taken during this year have been more than double that of the preceding year.

In landscape photography we fear that there has been less activity. One of the most distinguished dry plate photographers informed us recently that he had not taken one

iv

andscape during the summer, so absorbing have been the demands of portraiture. Nevertheless, we hope that the forthcoming Exhibition will not be wanting in good examples of landscape photography.

Instantaneous photography has excited much attention during the year, and its conditions seem to be better understood as consisting in simplicity rather than complexity. Good chemicals, good lenses, and good light; bromodized collodion, and iron development, are generally known to be the main requisites. Breese's wondrous instantaneous transparencies have excited so much admiration, that he has been induced to appoint London agents for their sale; and his moonlight pictures, at one time regarded by many as a hoax, are now received as veritable results. Wilson, Blanchard, Kibble, Harman, and others, have all added their quota of instantaneous results during the year, whilst England has not been less usefully engaged in producing many thousands of charming souvenirs the art treasures in the Exhibition.

We have had the pleasure of chronicling various minor improvements during the year, which do not need specific mention here. Although there still remains much room for improvement, there has been unquestionable progress in the art aspects of photography. The appliances of photography have been improved, its applications extended, and increased activity generally been manifested. Photographic societies generally have not been progressing. The London societies have, it is true, increased in numbers, and some of the provincial societies have also been prosperous; but there has been a general declension on the whole, many of the societies having either died, or sunk into a torpor which resembles death.

One of the most important and satisfactory events of the year was the passing of the new Copyright Act, which gives to the photographer the sole right to reproduce his own pictures, and checks piracy by the prompt enforcement of penalties.

We confidently anticipate, in the coming year, continued progress, and hope for all our readers renewed and increased prosperity.

AMMONIA DEVELOPMENT.

THE recent experiments in ammonia development are likely to suggest many valuable theoretical conclusions, both regarding the nature of the process of development, and the operation of preservative preparations. It is clear, for instance, from recent experiment, that the use of the coating of tannin is not merely of a mechanical character. It is not simply a varnish helping to render the desiccated film permeable by aqueous solutions, as has been suggested by some authorities. If this were the case, a solution of ammonia would be sufficient to develop plates prepared by other methods. We recently tried the effect of ammonia on plates simply washed and dried without preservative. No perceptible result whatever followed; but on the addition of a little pyrogallie acid to the solution, an image rapidly appeared. The negative was not a satisfactory one, as, on intensifying, fog and irregular deposit ensued. We had not time then to repeat the experiment, only having a single plate at hand. A letter recently received from Mr. Leahy confirms this result, and adds the interesting fact that carbonate of soda answers the same purpose as ammonia. He writes as follows:—

SIR,—Since my former communication on the subject of developing by ammonia, I have been trying some experiments, with the view of finding out whether the development was due solely to the ammonia or to the tannin and ammonia combined. For this purpose I prepared plates by the ordinary tannin, the Fothergill and Sisson's (borax and gum) processes. The pictures taken on the plates, prepared by either the Fothergill or the borax and gum process, could not be developed by ammonia alone, but were rapidly brought out by a mixture of tannin and ammonia. The

proper proportions seem to be, from 10 to 15 drops of strong ammonia to an ounce of the ordinary 15-grain tannin solution. The plates prepared by the borax and gum process gave beautiful results, when treated with the foregoing mixture of tannin and ammonia. The pictures were of a reddish brown, and very sharp and vigorous, even before the application of the pyrogallie acid and silver; the principal use of the latter (with pictures developed by the above) being to intensify, almost all the details being visible before its application. I have also tried a solution of common soda for developing tannin plates, and with almost as much success as the ammonia. A solution of tannin, with the addition of a little soda, will develop either the Fothergill or the borax and gum prepared plates, but rather slowly. The foregoing modes of developing would, I should think, succeed with any of the dry processes, but I have tried them only with those mentioned.

The development seems to be owing to some decomposition of the tannin, as, in its absence, neither the ammonia or the soda produced any effect.—Your obedient servant,

THOMAS M. LEAHY.

Dublin, 16th December, 1862.

In a recent letter, Major Russell adds some interesting remarks, which we subjoin. He says:—

“With regard to the ammonia development, I have had no failures in the way of working I have described, except in a few of the earliest experiments, before I had found out the proper proportions of ammonia, and the necessity of thorough washing before intensifying with the ordinary developer. When these points were attended to, there has never been in my hands the slightest tendency to fogging or irregular action. My plates, I may observe, were all thoroughly freed from nitrate, sometimes by immersion in strong solution of salt, and always were soaked for hours in common water. I have found, by careful experiments, that the ordinary mode of development can be made to bring out an image after nearly as short an exposure as the ammonia and pyro, by using at first a very strong solution of pyro, with a mere trace of silver and acid; but in cases of short exposure, the ammonia treatment, besides economising the pyro, appears always to have its advantage in brightness and cleanliness.

“You are not satisfied with my idea as to the manner in which the ammonia acts. I put it forward with diffidence, as very little is known on the subject; but if it is not the true one, it, at any rate, seems the most probable explanation. Ammonia, added to tannin or pyro in solution, causes discolouration of the same kind as is produced by the addition of nitrate of silver; and if this action takes place on an exposed plate, the appearance of the image takes place in a very similar manner, and is of the same colour. The chief difference is, that tannin and ammonia develop much more energetically than tannin and nitrate of silver.

“The difference between the energy of ammonia and nitrate with pyro is not so great; gallic acid with ammonia is intermediate in effect between tannin and pyro, when all are used with ammonia. In Mr. Leahy's experiments the development was produced by the action of the ammonia on the tannin. Mr. Hurst's theory that the ammonia only acts in making the developer penetrate cannot be right, as, with the collodion I use, the strongest solution of pyro will produce scarcely any trace of an image—usually no perceptible trace, in a quarter of an hour—the liquid containing enough alcohol to make it completely penetrate and whiten the film immediately, whilst the addition of one thirty-second of a drop of ammonia will cause the image to start out in all its details in a few seconds.

“The subject is rather obscure; I do not understand the action of heat with tannin alone; heat will discolour pyrogallie solution, but I think not tannin.”

Regarding the question of development, we differed from so careful an observer as Major Russell with considerable diffidence; but we felt that his view of the theory did not

account for all the known facts. At present we offer no theory, but wish for further evidence. The subject is a new one, and may prove wider in its suggestiveness than at present appears.

Scientific Gossip.

EXHIBITION OF COLOURED FLAMES TO AN AUDIENCE.—ILLUMINATING A LABORATORY WITH YELLOW LIGHT.—ESTIMATION OF ORGANIC MATTER IN WATER.—READY FORMATION OF BINOXIDE OF HYDROGEN.—EXAMINATION OF COLOURED GLASS.

AN easy way of exhibiting to many persons at once the striking phenomena of coloured flames, has long been wanted. Some metallic compounds need simply to be placed in a colourless gas-and-air flame on a platinum wire, for them to evolve the characteristic colour in sufficient copiousness to be plainly visible to a large audience; of these, sodium and its compounds, must be first mentioned, the readiness with which they give rise to the well-known yellow light being often painfully antagonistic to other experiments of this character; next follows lithium, the vividness of whose red light (when not eclipsed by the accompanying soda) is almost equally striking, and then perhaps may be ranged barium, strontium, &c. By employing, according to Mr. Crookes' suggestion, the various metallic chlorates, considerably better results may be obtained, but for demonstrations to an audience this plan is hardly applicable, in as much as the light, very vivid though it be at the time, is too much of a flash. What is wanted is some means of evolving a steady uniform light from each peculiar metal, unminged with any other colour. Messrs. Wolf and Diacon have lately proposed a plan which seems to fulfil all the desired conditions in a very perfect manner. They state that on passing a current of hydrogen through a slightly bent tube containing a volatile body in the lower part of the bend, and heating this strongly, the gaseous jet escaping at the open extremity is charged with the vapours of this body, increasing in quantity with the increased heat applied to the tube. By igniting the hydrogen a coloured flame is produced, which in some instances becomes dazzling, when the combustion is stimulated by a jet of pure oxygen.

Many metallic chlorides, but especially alkaline metals, and their volatile compounds, produce, under these conditions, perfectly distinct, and very lasting coloured flames, by placing in the tube a sufficient quantity of material. Upon examining these flames in the spectroscope very curious appearances are produced. A globule of sodium heated in an iron tube, through which a hydrogen current is passed, gives an intensely bright jet, in the spectrum of which appear six well-defined rays, all being clearly marked upon a slightly coloured ground. This ground is not continuous, but has two sudden variations in intensity; the first of these tints is remarkable for its correspondence with a green line, which appears to depend upon the existence of an excess of sodium vapours. By raising the temperature of the iron tube so as to increase the quantity of metallic vapour carried off by the hydrogen, the green band makes its appearance, limited by a very fine green line between β of calcium and δ of barium, and at the same time is observed the effect, remarked by Fizeau, the reversing of the brilliant yellow ray, due to the sodic vapours, surrounding the flame. Potassium, slightly heated under the same conditions gives a magnificent flame, which can easily be maintained for a long time by the successive addition of metallic globules. The rays composing the spectrum of this metal are ten in number, and have for the most part been described by MM. Grandeau and Debray. When potassium and sodium are introduced together into the tube, the spectrum of the potassium at first appears alone, but as it fades the sodium rays appear with glowing intensity. By observing the two spectra thus superposed, it is easy to decide upon

the relative position of the rays of the two metals. It is then seen that the blue lines of sodium and potassium in no way coincide. In trying their experiments they had no metallic lithium, but the same method applied to the chlorides of the preceding metals having given very clear spectra, though not so brilliant as with isolated metals, these experimenters were enabled to replace this metal by one of its volatile compounds. Instead of the iron tube, a small tube was used formed of platinum plate rolled round on itself; by heating in it pure chloride of lithium, four characteristic and very brilliant lines are obtained, one of the lines, a blue one, corresponding almost exactly with the faintest of the two blue caesium lines. Numerous experiments made upon these various bodies, and particularly on sodium, yielded identical results, whatever method was employed to volatilize either the metal or one of its compounds. By using sodium electrodes in Ruhmkorff's induction apparatus, the sparks exhibit all the above-mentioned rays, on which is superposed the spectrum of the circumambient gas whenever the spark is accompanied by a luminous atmosphere.

Volatilisation in a hydrogen current seems to be applicable generally. It has been successfully applied to chloride of calcium; and though with chlorides of strontium and barium, which are not sufficiently notable, the results are not superior to those obtained by the ordinary method, it is very successful with the chlorides of copper, zinc, &c., which give spectra so distinct and intense as to render the study of them exceedingly easy. With some metallic compounds this light is so brilliant that it may be advantageously employed for the projection of the phenomena on to a screen for lecture demonstrations.

To the photographer these results possess considerable interest. The hydro-sodium flame is luminous enough to illuminate a laboratory with brilliancy, whilst its actinic power is absolutely *nil*. It would thus be invaluable in the photographer's dark room; the only drawback would be the alkaline character of the vapours arising from the combustion. These could, however, be easily removed by a chimney.

Organic matter in water is always a serious impurity, but few suffer so much from its presence as photographers. Dr. Woods has recently devised a very simple method of determining the amount of organic matter so present, which appears likely to be useful. The method is based upon the reducing action exerted by the organic matters dissolved in the water upon permanganate of potash, employed as a standard solution. A litre of water is mixed with a decided excess of pure sulphuric acid, and warmed in a porcelain basin to a temperature of 140° Fahr.; the solution of permanganate is then added, drop by drop, from the burette, until the pink tinge is permanent for half an hour. The "chameleon solution" contains one milligramme of crystallised permanganate in a cubic centimetre of distilled water; with this strength, the water supplied to Chatham requires from 2.4 to 7.5 cubic centimetres to produce a permanent coloration. It is necessary to exclude the interfering influence of iron in the state of protoxide, so that when this constituent is present the water should be evaporated to dryness, the residue ignited, dissolved in sulphuric acid, and reduced by sulphurous acid, when the same standard solution will give the amount of iron, and a deduction can be made accordingly. Thus in possession of a method of determining the amount of organic matter of a transitional nature or reducing character, it becomes necessary to institute a standard of comparison, for it would be practically impossible in each instance to identify the kind of organic impurity. Dr. Woods selects for his standard oxalic acid, and with weighed quantities he estimates the volume of permanganate required to destroy it; the results of analysis are therefore stated directly in accordance with this standard, and can at any future time be translated whenever the specific character of the organic matter present in any other sample shall have been ascertained. As instance of the kind of

results obtained by this method sewage water, and a sample drawn from a pump in the neighbourhood of a cesspool have been tested by this method; the latter was found to contain no less than five grains of organic matter (oxidisable) in the gallon. Photographers would do well to practise this simple kind of test occasionally, for oxidisable organic impurity is especially injurious in their operations.

Somewhat allied to the subject of purification of water is the formation in a ready and cheap manner of binoxide of hydrogen, which has just been accomplished by Mr. Duprey. By passing a very rapid current of pure carbonic acid into distilled water, and adding at intervals binoxide of barium, perfectly pure oxygenated water is obtained. When the quantity of carbonate of baryta is sufficiently large to obstruct the passage of the gas, the clear liquid containing all the oxy-water must be decanted, and the current of carbonic acid again passed into it.

As soon as more binoxide of barium is thrown in, a fresh quantity of oxygenated water is formed. In this way we obtain water strongly charged with perfectly neutral and pure oxygenated water, which can be concentrated under an air pump. Care must be taken to maintain a sufficiently rapid current of carbonic acid so as always to be in excess of the small and gradually added binoxide of barium, which must, moreover, be finely powdered, as large pieces escape decomposition. The carbonic acid must be washed carefully by passing through flasks containing carbonate of lime. The best re-agent for oxy-water is decidedly permanganate of potash which, poured into water containing even a very small portion of oxygenated water, disengages all its oxygen. This body serves, therefore, to estimate oxygenated water as well as organic matter, the phenomena of decoloration being very apparent.

Three samples of glass have been sent for examination in the spectroscope. No. 1 (S) is of a brown colour, and admits of the passage of several active rays. It is, therefore, inapplicable for photographic purposes. No. 2 (F. Lane) is of an orange colour, and, in the instrument, appears almost perfect. Some few actinic rays, however, struggle through. No. 3 (Mr. Wilkinson) is similar in colour to No. 2, but a trifle darker. As a photographic screen, it is excellent, the whole of the active rays being cut off by it.

SPIRIT PHOTOGRAPHS.

CONSIDERABLE interest is at present excited in certain circles in America by the alleged production of photographic portraits of disembodied spirits! We alluded to the subject in a recent paragraph, as a *canard*. We now find a good deal of matter on the subject, collected from various sources, in the *Spiritual Magazine*; and as photographers generally will be concerned in preventing their art being made the vehicle of imposture, we give some copious extracts. It is scarcely necessary for us to say that the presence of additional ghostly images on the plate, besides that of the real sitter, is easily compassed. The evidence fixing the identity of such phantom images, and as to the mode of producing them, we leave without comment to the good sense of our readers.

The facts, as narrated by Dr. H. F. Gardner, of Boston, are as follows:—

“Mr. W. H. Mumler, an amateur photographer and practical chemist of Boston, was engaged on Sunday, October 5th, at the photograph gallery of Mrs. Stuart, at No. 258, Washington Street, in adjusting the chemicals, which had become disarranged. Having prepared a plate, and placed a chair near the focus of the camera, by which to adjust it, he proceeded to take his own photograph, card size, by quickly jumping into position and standing still the required time. The picture—a copy of which we have seen—represents Mr. Mumler as an active, rather athletic-looking man, standing with his coat off, and the black cloth, used to cover the camera, in his hand. Upon the back of this card appears the following statement:—‘This photograph was taken of myself, by myself, on Sunday, when there was not a living soul in the room beside me—’ so to

‘speak.’ The form on my right I recognise as my cousin, who passed away about twelve years since.—W. H. MUMLER.”

“The form referred to is that of a young girl apparently sitting in the chair, which appeared on developing the picture, greatly to the surprise of the artist. The outline of the upper portion of the body is clearly defined, though dim and shadowy. The chair is distinctly seen through the body and arms, also the table upon which one arm rests. Below the waist, the form (which is apparently clothed in a dress with low neck and short sleeves) fades away into a dim mist, which simply clouds the lower part of the picture. Mr. Mumler affirms that this form bears a likeness to a spirit cousin, and its appearance was equally unexpected and startling to the artist, who was not a believer in spiritualism, though perhaps somewhat interested, and had no reason to suppose himself a medium.

“Since this accidental discovery, we are assured by Dr. Gardner that at least a dozen similar photographs have been taken, a new spirit form appearing at the side of each subject. The artist experiences a loss of strength in the process that limits him to three or four sittings per day. The forms are not as distinct as we could desire, yet they are sufficiently marked to prove individuality to friends. Dr. Gardner kindly left with us two specimens of photographs taken subsequently to the one we have described. They are card photographs of a gentleman and his wife, residents, we believe, of Chicopee. On the picture of the lady stands beside her a female form, recognised by both parents as the likeness of a spirit daughter. The upper portion of the form is quite distinct, but the lower fades out in the form of flowing skirts, partly covering the mother’s dress, till quite indistinct at the floor. The other has a less distinct form, yet one recognised by the gentleman as that of his mother in the summer land. A peculiarity about this picture—less distinct though it is—renders it one of the most interesting we saw. The upper portion of the shadowy figure alone has a recognizable form, and this is so large, that were the figure to be completed in due proportion, the feet would be carried some distance below the floor. It is a magnified image of a human (or spirit) head, hardly possible to have been produced from any visible object within range of the instrument. And the arm of the spirit seems thrown about the neck of the subject (her son), the hand resting like a little cloud of mist upon the opposite shoulder. Witnesses were present, in all cases except the first, to testify that only one person sat for each picture, and yet we are assured that in some instances three additional forms appear. Similar results to those mentioned above can perhaps be produced by any skilful photographer, by introducing forms during a portion of the time a plate is exposed, or reflecting an image upon the sensitive surface in the dark room. We trust scientific and truth-loving photographers will experiment, that, if possible, the fraud or accident, if either exist, may be exposed, or the means made use of by spirits to project an image upon the air exposed to the line of vision of the camera be discovered.”

We next hear that Mr. William Guay, a practical photographer, had undertaken to test and verify this matter. He thus writes on the subject to the *Banner of Light*, a Boston paper:—

“Boston, Nov. 18, 1862.

“MR. EDITOR,—Having been informed by Mr. William H. Mumler that you desire to publish the results of my investigation into the possibility and genuineness of Mr. M.’s photographic impressions of spirit forms, it gives me much pleasure to detail to you what I have seen. As I have been commissioned by Messrs. A. J. Davis and Co., you can rest assured that I was resolved, if permitted, to allow nothing to slip my utmost scrutiny. Having had ten years’ continual practice in this particular branch—that is, negative on glass, and positive on paper from negative—I felt competent to detect any form of deception.

“Having been permitted by Mr. Mumler every facility to investigate, I went through the whole of the operation of selecting, cleaning, preparing, coating, silvering, and putting into the shield, the glass upon which Mr. M. proposed that a spirit form and mine should be imparted, never taking off my eyes, and not allowing Mr. M. to touch the glass until it had gone through the whole of the operation. The result was, that there came upon the glass a picture of myself and, to my utter astonishment—having previously examined and scrutinized every crack and corner, plate-holder, camera, box, tube, the inside of the bath, &c.—another portrait.

"Having since continued, on several occasions, my investigations, as described above, and received even more perfect results than on the first trial, I have been obliged to endorse its legitimacy.—Respectfully yours, Wm. GUAY."

"In a letter of the 26th November, after having made a full and minute report of his visits, Mr. Guay reports to Messrs. Davis and Co. as follows:—"The weather has been too unfavourable since Saturday to print from the negatives, on one of which I perfectly recognise the likeness of my father. The picture of my wife is very faint, but sufficient for me to recognize the features. It is impossible for Mr. Mumler to have procured any pictures of my wife or father." He also says that whilst he sat for the two pictures he mentally desired that the likenesses of his father and of his mother should be produced.

"Another photographic artist, Mr. H. Weston, of 31, Province-street, Boston, writes that after making a full examination of the process, he found a spirit-figure on the negative. He also says that he cannot conceive of any process by which imitations could be made without his detection."

(To be continued.)

TONING WITH GOLD AND LIME.*

THE tone of French prints is often very much admired, and we believe they are in the majority of instances produced by a bath containing lime in combination with the gold. We are indebted for the following formula to Mr. Parkinson, of Dieppe, who showed us some very exquisitely toned prints produced by it. He informed us that it was almost universally used among French portraitists. It is by M. Ommeganck, and originally appeared, we believe, in the *Bulletin Belge*; but as we receive it in French MS., we are a little uncertain of its origin. The tones are a rich deep black, quite free from mealiness, blueness, or slatiness in the shadows, and have warm tint in the half-tints, which is very valuable and flesh-like in portraiture. The formula stands thus:—

Chloride of gold.	15 grains.
Carbonate of lime	150 "
Chloride of lime..	23 "
Water	7 pints.

Dissolve in *aqua regia* (nitric acid one part, hydrochloric acid two parts), metallic gold 90 grains; after solution, add 30 grains of common salt to prevent decomposition during evaporation; evaporate by a gentle heat, until the saline mass contains no excess of water. It is not necessary to push the evaporation to complete dryness; a trace of acid is not of much consequence. Dissolve the salt of gold thus obtained in three ounces and a half of rain or distilled water, and you have a solution containing about 45 grains of chloride of gold to the ounce of water. It is not, with this preparation, necessary to weigh every time small quantities are required, nor is it necessary to preserve it from moisture. This salt of gold, generally called chloride, is a hydrochlorate of chloride of gold; the formula stands thus:— $AuCl_2ClH$, in round numbers, metallic gold 200, chlorine and hydrogen 140, together 340; reducing we shall have $10+7=17$; multiplying by 6 we shall have gold 60, chlorine and hydrogen 42, together 102; then 90 grains of gold will yield about 150 grains of the hydrochlorate in question. Two drachms and forty minims of the solution are taken and triturated in a porcelain mortar with 150 grains of carbonate of lime. If it be intended for immediate use, the preparation should be left in contact for one hour; if on the morrow—and this is best—ten minutes will be found sufficient. By this treatment the chloride of gold abandons its acid and a certain portion of its chlorine. The whole of the operations should be conducted by the heat of a water bath, in winter, at a temperature of between 70° and 80° Fah. Carbonate of lime being nearly insoluble, a slight excess of it is not so important as an excess of carbonate of soda. The reaction being completed, 28 grains of chloride of lime (hypochlorite of lime) are added; this latter salt should be specially pre-

pared and preserved in closely-stoppered bottles, on account of its tendency to become humid and decompose in damp air. After that add 35 ounces of water, filter, and then add 5½ pints more water, and preserve in stoppered bottles. When this bath loses its toning properties through age, without having been exhausted, it may be restored by the addition of about four drops to the pint of a ten per cent. solution of chloride of gold. When the bath has lost its smell, it may be restored by adding a few drops of a fresh solution of chloride of lime. Either this or a few drops of solution of chloride of gold will restore its action after it has been partially used, and has grown inert.

On immersing the print in the hypo bath, the tone of the proof changes at once to a violet brown; but, as soon as it is properly fixed, it returns to a bluish black. Finally, the prints are washed, as before described. The hyposulphite bath should only be used once.

ON THE COAGULATION OF ALBUMEN.

BY M. MC. A. GAUDIN.*

[We are glad to find that M. Gaudin has been following up and verifying our experiments on the coagulation of dried albumen. His further suggestions may be valuable if they prove true in practice.]

THE familiar fact of the coagulation of albumen, manifested every day in the cooking of eggs, has probably greatly contributed to lead chemists, as well as photographers, to believe, that dried albumen possesses the same property of coagulation; hence the directions given, and doubtless frequently followed, of passing a hot iron over albumenized papers before sensitizing them on the nitrate of silver bath. The precaution of ironing the paper is taken to coagulate the albumen, and prevent it from leaving the paper and mixing with the bath.

During the past few months many articles have appeared in the photographic journals tending to prove that albumen, previously dried, no longer undergoes coagulation by heat; but this absence of coagulation, which means that albumen continues easily soluble in water, was not in this way clearly explained; and this it was that decided me to prove the truth by experiment.

I took white of eggs dried spontaneously, having the appearance of dry transparent scales of a straw colour; I dissolved a portion in warm water. The solution soon formed a viscid liquor, and was quickly converted into froth by beating. I wrapped another portion in paper, and exposed it for an hour in an oven heated to the temperature of boiling water, where the portion previously dried had become a solid mass. The dried albumen thus heated became entirely dissolved, forming a frothy liquid, exactly as if it had not been exposed to heat, consequently, dried albumen loses none of its solubility by being exposed to the (dry) temperature of boiling water.

In order to ascertain whether the result would be the same if the albumen were exposed to a higher temperature, I wrapped another portion in paper and placed it in a sand-bath, so hot as to scorch the paper and the albumen enclosed in it. At the close of the experiment the greater portion of the albumen was scorched, emitting the odour of burnt egg.

In this instance warm water dissolved the unscorched egg, leaving the scorched portion intact; and upon heating the liquid to ebullition, it remained limpid, even ceasing to froth, immediately absorbing its bubbles as soon as the vessel was withdrawn from the fire. From this we must conclude, that albumen, previously dried, remains entirely soluble in water, whatever the temperature to which it has been submitted, providing this temperature is not high enough to scorch it, or cause decomposition to commence; and albumen, intact, but burnt, ceases to be coagulated by heat even after it has been dissolved again.

Dried albumen, dissolved without being submitted to heat,

* From an article on "Methods of Toning" in our YEAR BOOK OF PHOTOGRAPHY FOR 1863.

* La Lumiere.

is coagulated by heat; but I have noticed that, by this simple desiccation, it does not dissolve as readily as albumen fresh from the egg, which compels me to conclude that any degree of desiccation weakens the faculty of coagulation.

From this it results that the passing a hot iron over paper covered with dried albumen produces no effect, and that the presence of water is essential to obtain coagulation. In all probability, a minimum quantity of water suffices to produce this phenomenon; as to the paper, if already dry, it is sufficient to place it in a cellar, or other damp place, for a time, for the albumen to become coagulated by the passing of a hot iron over it.

To render albumen in the dry state insoluble, we must have recourse to chemical actions. Dry albumenized paper immersed in absolute alcohol, abandons its albumen to water as soon as the alcohol is evaporated; concentrated gallic acid no longer producing any effect on it. It is different with the metallic salts: the salts of silver and of mercury, for instance, produce insolubility. With the albumenized papers in a dry state this is an essential point, as they must always be sensitized on the silver bath before they can be used, only it would be preferable for the albumen to be coagulated in advance; and if, heretofore, the passage of a hot iron over the dry paper was in reality without effect, it is now certain that on performing the same operation at the proper moment, that is, while the coating of albumen is still moist, or is rendered so by exposing the dried paper in a damp place, an excellent effect will result, which absolutely prevents the separation of the albumen, which so frequently spoils the silver baths. For the preparation of albumen on glass, it will be also useful to take this experience into account by submitting the coated plates to a degree of heat suitable to coagulate the albumen, before they become completely dry, so as not to take this trouble in vain, inasmuch as the introduction of albumen into the bath is much more mischievous in this case than in the other.

Albumen is an organic substance, the complexity of which has remained hitherto impenetrable to chemical investigation: in all probability its molecule is composed of a great number of atoms, (since sulphur forms a part, yet cannot be separated, because its proportion is so small,) then its weight is considerable: and it is this that induces me to say that a very small proportion of water suffices to promote its coagulation. This useful proportion is actually disengaged only when the desiccation has arrived at its last limit, and we can be certain of succeeding in coagulation only when the paper appears not quite dry to the touch.

[The amount of moisture necessary to secure the conditions for coagulation is an interesting subject for inquiry. Mr. J. W. Osborne recently remarked to us, that in the preparation of his photolithographic transfer, he has observed, that when the paper, coated with gelatine and albumen, was floated on boiling water, face upwards, no coagulation of the latter took place at boiling heat until the whole had become thoroughly permeated with moisture, and that, by observation and experience only, could the proper time be determined.—Ed. P. N.]

PHOTOGRAPHY IN THE POLICE COURT.

PHOTOGRAPHY and photographers have recently been figuring in the police court. Besides the recent copyright infringements, there have been, within the last week, two or three criminal cases, which we give as reported in the daily papers. The first was before Mr. Elliot, at Lambeth, and stands as follows:—

ROBBERY AT THE CRYSTAL PALACE.—*George Restall*, a young man, who has been manager of the business—in the Crystal Palace—of Messrs. Negretti and Zambra, was charged with stealing thirteen lenses of the value of £60, the property of his employers.

Mr. H. Negretti deposed that the prisoner was employed by his partner and himself to conduct their business at the Crystal Palace, at a salary of £3 a week, and about a fortnight since

he came to them and said he had missed as many as nineteen lenses from his stall in the palace, and mentioned the name of a party whom he suspected. He (witness) told him at once to communicate with the police at the palace; but instead of doing so, he gave information of the alleged robbery at Scotland-yard, giving as his reason that the police of the palace were too friendly with the suspected party. Three of the four lenses produced were the property of witness and his partner, and were a portion of those missing.

A shopman to Mr. Blizzard, pawnbroker, in the Borough, produced the four lenses, and said that they had been pledged with him by the prisoner, who described them as his own property.

Sergeant Palmer, a detective, said that about a fortnight ago he received instructions to make inquiries respecting thirteen lenses stolen from the Crystal Palace. He saw the prisoner on the subject, and in his account about the lenses he said they were safe about three weeks ago, though in his information he mentioned that they had been gone six months. He asked him if he pawned them, or either of them, when he not only positively denied having done so, but declared he had never been in the shop of a pawnbroker in his life.

The prisoner, who denied the charge, was remanded to a future day.

On Tuesday last the case was again heard, when Mr. Sleight appeared for the defendant, and Mr. Lewis, jun., for the prosecution.

Mr. Negretti said that since the last examination he discovered other lenses missing, and requested a further remand, to give time for tracing the other property, and which, with that produced, was of the value of from £90 to £100.

Mr. Sleight represented the prisoner as a person of high respectability, and he felt quite sure, incapable of committing the offence attributed to him, and examined the witnesses at some length, after which the prisoner was again remanded, but admitted to bail.

We sincerely hope that at a future hearing Mr. Restall may be able to prove his innocence, as we know him to be a skilful photographer, and should be sorry to think him a dishonest one. The next case was heard at Marlborough Street, before Mr. Tyrwhitt, and stands thus in the report:

THE MAJOR AND THE PHOTOGRAPHER.—*Winter Thompson*, photographer, Oxford-street, was summoned before Mr. Tyrwhitt for assaulting Major Lister.

The evidence of the major went to show that he went to the defendant's with his wife and child, six years of age, to have the latter's portrait taken, and there saw a female, who said that if the first portrait taken was not approved of, a second should be taken, there being also a notice up to a similar effect. A portrait was taken, but as the child's head, owing to the position in which the child was placed, was sunk between its shoulders, he objected, and asked for another; but the artist rudely objected, said it would do very well, and on his going down stairs, declining to go on with the transaction, a man (Mr. Thompson, jun.) rushed out of a door on the left hand side of the passage, and pushed him back, threatening to knock him down. Another man (the defendant) then rushed out of another room and seized him by both hands. The defendant then retired, at his son's request, and an altercation of a violent nature on the younger Thompson's part ensued, in the course of which he said that he was justified in detaining him (the major), and taking his life. The cost of the portrait was to be half-a-crown.

Mr. Edward Lewis, of Great Marlborough-street, for the defence: The major said that he had been to the Messrs. Southwell's, the photographers, previously, but was perfectly satisfied with the reception he there met with. Mr. Thompson did not say that if he pointed out any fault he would do another. He did not wait for the photograph, and only was reluctantly shown the negative.

Mr. Thompson, jun., was called as a witness for his father, and said the complainant would not point out any fault in the negative, but peremptorily refused to have the portrait, and refused to give his name and address, or to pay the 2s. 6d. for it.

A young woman named King, in the employ of the defendant, said that the major wished to arrange the child himself, and would not let the artist do so. Mr. Thompson, jun., did not push him, and Mr. Thompson, sen., rushed out of the room, and said the major should not strike his son.

Robert Cousins, artist to the defendant, said that he told the major that he was not a judge of a negative, as he was not a photographer, and the major then went off in a tiff.

Major Lister said he should like to ask the artist if there was not a notice up, stating that if the first portrait was not approved of a second would be taken.

The witness said that was the case, but the portrait had not been shown the complainant, only the negative.

Mr. Tyrwhitt said he thought the complainant had been too hasty in the matter. He did not see, until the positive was taken, how any person could be a judge of a portrait. He thought there was a misunderstanding altogether, and should dismiss the summons.

On the same day, at Guildhall, there was another case, with no further photographic interest than that it was a robbery in a photographic establishment.

CASH ROBBERY.—George Bates, a porter, lately in the employ of Mr. Newcombe, of the London School of Photography, 103, Newgate-street, was charged before Alderman Humphrey with breaking open his master's cash-box, and stealing therefrom £160.

Inspector Wilson, of the C division, said the prisoner surrendered himself at the Vine-street Police-station; and after receiving the usual caution, he was told that the charge against him was for robbing his employer of £160. He then stated that he broke open the cash-box and took away the money, but that while proceeding to Bristol he was robbed of the greater portion of it. He also said he had twice contemplated suicide, but that he could not muster up courage enough to destroy himself.

Wm. Joseph Anderton, the manager of Mr. Newcombe's establishment in Newgate-street, said the prisoner had been in their employ about twelve months, first as porter, and afterwards as assistant in preparing the materials for the use of the artist. His wife was also housekeeper in the same establishment, and lived with the prisoner on the premises. On the night of the 25th of November last he put £150 into the cash-box, and put the key on the top of the safe, and when he arrived on the following morning he discovered that £157 19s. 4d. in gold and silver was gone, but that a large amount in notes, cheques, and postage-stamps, had been left behind. The cash-box had been forced, and, as the prisoner absconded very suddenly on that day, suspicion fell upon him.

Mr. Martini, the chief clerk, said a warrant was issued from this court on the 27th of November, for the prisoner's apprehension.

Alderman Humphrey asked what had become of the prisoner's wife? Witness said she and her two children had been in the Bow Union ever since the prisoner went away.

Alderman Humphrey asked the prisoner what he had done with all the money?—The prisoner replied that he did not wish to answer any questions, as he admitted he was guilty.

Alderman Humphrey inquired what sort of character the prisoner had previously borne?—Witness said he came from Mr. Greer's, the cutler, in Newgate-street, with an excellent recommendation. He had also held the situation of engine-keeper and organ-blower at Christ Church, Newgate-street.

The prisoner was remanded.

The International Exhibition.

REPORT OF THE JURY ON PHOTOGRAPHY AND PHOTOGRAPHIC APPARATUS.*

EARLY HISTORY OF THE ART.

THE present gathering of works in Class XIV. of the International Exhibition will mark an epoch in the history of photography. For the first time, in the crescent of all the arts and sciences, it is recognized as an independent art.

In the London Exhibition of 1851, sun pictures were grouped with philosophical instruments; in the Paris Exhibition of 1855, with printing and applied design; so that, in the first, a photographic landscape was supposed to hang in its proper place, behind a sextant or a voltaic battery; in the

second, among paper-hangings, candlesticks, and children's toys. That era of confusion has now been passed, and photography has obtained a distinct place in the arts—it is admitted to rank as a separate class.

As this public reception of photography into the great sisterhood of the arts will close the first period of its existence, and open a new and larger field of endeavour, it may be well to recall very briefly a few leading facts of its public history up to the state at which the present report will have to make a more minute and technical record of its efforts.

Photography, as a practical art, only dates, as it were, from yesterday, though some of the natural laws through which it works were subject to investigation and speculation in ancient times.

Three hundred years before Christ, Ruelid appears to have observed the principle of the stereoscope, and Galen, subsequently, in his work "On the Use of the Different Parts of the Human Body," has fully described the various phenomena which occur when viewing any body with both eyes, and then, alternately, with the right and left. Mr Hunt has traced, with much zeal, in his "Manual of Photography," the progress of the discoveries of the various minds by which the art has been built up, and describes the researches of Liectus and Kircher, in 1646, on the phosphorescent influence of the sun's rays. That Petet, in 1722, found that solutions of nitrate of potash and muriate of ammonia crystallized more readily in light than in darkness. In 1777, the illustrious Scheele gave, in the following account, the first philosophical examination of the peculiar changes in the salts of silver, and showed the dissimilar powers of the different rays of light in effecting their change. He says:—"It is well known that the solution of silver in acid of nitrate poured on a piece of chalk, and exposed to the beams of the sun, becomes black. The light of the sun reflected from a white wall has the same effects, but more slowly. Heat, without light, has no effect on the mixture. Fix a glass prism at the window, and let the refracted sunbeams fall on the floor; in this coloured light put a paper covered with luna cornea, and you will observe that this horn-silver grows sooner black in the violet ray than in any of the other rays." Senebier repeated and extended similar experiments in 1791. Fischer added to our knowledge in 1795. Count Romford published, in the "Philosophical Transactions" of 1798, "An Inquiry Concerning the Chemical Properties which have been Attributed to Light;" but Mr. Robert Harrop published, in "Nicholson's Journal," in 1802, a communication in which he negated the experiments of Count Romford, and proved that the actions described by him were due to light, and not to heat.

In June, 1802, Sir Humphry Davy published, in the "Journal of the Royal Institution," an "Account of a Method of Copying Paintings upon Glass, and of Making Profiles by the Agency of Light upon Nitrate of Silver." Sir Humphry Davy had conjointly experimented with Mr Thomas Wedgwood, considerable success attending their researches, and Sir H Davy concludes with this observation:—"Nothing but the preventing the unshaded parts of the delineations from being coloured by exposure to the day is wanting to render the process as useful as it is elegant." Wedgwood and Davy failed entirely to fix the produced image; and, with the exception of some further contributions to our aid from Drs. Young and Wollaston, no great step was made until 1814, when Joseph Nicéphore Niepce made the first permanent successful result. He named his process "Heliography," and in 1827 he presented a paper to the Royal Society on the subject; but as he kept his process then as a secret, it was not received. The memoir was accompanied with several specimens of his success on plated copper and pewter, and were afterwards distributed amongst his friends in London. By the favour of Mr Joseph Ellis, of Brighton, an opportunity has lately been afforded to closely examine one of these specimens. It is the copy of an engraving produced by the action of light in a camera on a layer of bitumen covering a silvered plate of pewter. It is not altogether in effect unlike a Daguerreotype, but wanting in the unpleasant metallic brilliancy, and having considerably more depth of tone in the shadows, which, it is stated, was produced by a subsequent application of the vapour of iodine. This specimen had been given by Niepce to his landlord, when he resided at Kew, and is so inscribed. The patient and persevering endeavours of Mr Ellis, who is the author of an instructive work, "The Progress of Photography," to procure this specimen, and save it from oblivion, are well worthy of praise.

The processes of M. Niepce were afterwards published, and he appears to have entered into a sort of partnership with M. Daguerre, who, in 1824, began a series of experiments with a view of fixing the pictures which had been taken in the camera; but it was not until the 7th of January, 1839, that Daguerre made his communication to the Academy of Sciences of his invention of the process known as the "Daguerreotype."

Mr. Fox Talbot, of Lacock Abbey, who had experimented since 1833 in photographic researches, on January 30th in the same year, 1839, communicated his discovery to the Royal Society of his process for multiplying photographic impressions, and which were then generally known as photogenic drawings. The investigations in France, by M. Daguerre, and of Mr. Fox Talbot, in England, were perfectly independent of each other.

The Rev. J. B. Reade, in April, 1839, took pictures of natural history by means of the solar microscope. Nitrate of silver was employed to sensitize the paper, and a solution of nut-gall washed over just previous to use: the paper being used wet, considerable sensitiveness was thereby secured. In the same year, 1839, on the 29th of May, Mr. Mungo Ponton made a communication of great importance to the Royal Society of Arts of Scotland, on the use of bichromate of potash. Sir John Herschel also used glass plates at this period, and published several valuable papers on the progress he had made towards the development of photography.

It was not until February, 1848, that Mr. Fox Talbot patented the process which, for a long time, bore his name, and which was subsequently changed to that of Calotype.

Recording merely the names of Mr Hunt, Dr. Draper, M. Bequerel, M. Claudet, M. Bayard, M. Niepce, Mr. Candell, Dr. Wood, Professor Wheatstone, Sir David Brewster, and others, we come to that of Mr. Archer, who, in 1851 just before the opening of the Exhibition in that year, published his collodion process. Although albumen had been extensively used, it never became popular, and, with the exception of Ross and Thompson, of Edinburgh, some few in England, M. Martens, M. Ferrrie, and a limited number in France, it did not maintain its position, chiefly from its great want of sensitiveness, and the greater facilities afforded by collodion. Previous to the Great Exhibition of 1851, it will be recollected that no collodion pictures were publicly exhibited; and we are exclusively indebted to the late Mr. Frederick Scott Archer for his application of collodion. Although very many details have been perfected, and many labourers have devoted hours in successful improvements, it must not be forgotten that Archer published his

* The following gentlemen constituted the Jury:—High W. Diamond, M.D., F.S.A., Secretary, London; A F J Claude, F.R.S., London, Photographer; Baron Gros, Chairman, France, Senator; Lord Henry Lubbock, M.P., Deputy Chairman, London; C T. Thompson, London, Official Photographer, Science and Art Department; assisted by B. Delessert, France; Lieut.-Colonel Demanet, Belgium, Member of the Department of Fine Arts of the Royal Academy of Belgium, as Associates.

collodion process—a truly useful and practical one, which, even up to the present time, cannot be said to have received such aid from any single contributor as to detect from the greatness of his first application. At what date Mr. Archer first used collodion is unknown; but this much is certain, that he first explained the process to his friends on the 21st September, 1850, at which time he was as well acquainted with its valuable properties as he was at the time he published it in March, 1851, in *The Chemist*.

Mr. Archer had been brought up at a silversmith's, but, not liking his occupation, some friends succeeded in placing him in a position more congenial to his feelings. He commenced as a sculptor, and wishing to preserve for himself records of the works which he had executed, induced him to study photography. For some time he had used the calotype process of Mr. Fox Talbot, to which he was the first to apply the pyrogallic acid; but he complained of the difficulty in procuring paper suitable for his work, and, with a view to form a finer surface to the paper, he first covered this iodized paper with collodion, and afterwards sensitized the paper by entire immersion.

The next thought was to combine an iodide direct with the collodion, and apply the collodion to glass. In his early instructions and practice, the collodion film was always removed by Mr. Archer from the glass on which the picture was taken.

It has been stated by some that M. Le Gray, in Paris, about the same time, and quite independently, also conceived the idea of improving the surface of paper with collodion. Whatever question there may be about this application of it, there is none whatever that the application of collodion to glass alone was an original and prior thought and application of Archer's. Mr. Archer, although possessed of many gifts, did not possess that of delicacy of manipulation, and, at the same time, he was always more anxious for research than the taking of photographic pictures; hence some of his friends succeeded far better than himself in obtaining satisfactory results from the process he had invented. It is satisfactory, as clearly establishing how little success had attended M. Le Gray's practice, that Mr. Archer applied to a friend, in the early part of 1852, for some specimens to forward to Paris, to prove what good results might be obtained with collodion under ordinary care.

(To be continued.)

Correspondence.

FOREIGN SCIENCE.

[FROM OUR SPECIAL CORRESPONDENT.]

Paris, 31st December 1862.

At the last meeting of our Photographic Society, a communication from Dr. Sabattier was read, on the means of obtaining direct positives on glass. He says:—"At the meeting of the Society in July last, when my note on direct positives obtained by the aid of diffused light was read, the President remarked, that in order to be able to judge of a process, an essential condition is to have its products before our eyes, and invited me to send some proofs in support of my communication. In reply to this invitation, I now send the Society a dozen of my pictures. It would have been easy for me to have sent a much greater number, but as it is sufficient to have well defined the circumstances under the influence of which is manifested a phenomenon which can be repeated indefinitely, it seemed to me that this dozen pictures will establish, indisputably, that we can constantly and regularly, by flooding it with light, convert a negative, sketched in the darkness of the operating-room, into a positive.

"These pictures, are, it is true, not free from defects; but the competent judges to whom I now submit them, will readily perceive that the defects must be attributed to the operator, and not to the process.

"In the hands of an operator better acquainted with photographic manipulations, the process will satisfy all the requirements of the art. A very few experiments will serve to convince the most sceptical.

"I cannot too often repeat, that nothing can be easier and simpler than to make a direct positive, while at the same time nothing can be more curious. As the materials and the manipulations remain the same, without any new baths or washings, by merely giving access to diffused light at a certain moment, we suddenly convert the faint negative into a positive.

"In my previous communication, I announced three conditions as indispensably necessary to the manifestation of this phenomenon.

"1st. To give access to diffused light before the negative arrives at its perfect state.

"2nd. To sensitise with a perfectly neutral bath.

"3rd. To develop with pyrogallic acid, to which acetic or other acid, not too energetic, is added.

"Recent experiments have shown me that the second of these conditions, deduced from misinterpreted facts, is not indispensable; that we can as easily obtain positives with an acid sensitizing bath, as with one that is neutral, which latter, however, gives the best results.

"Two conditions only are therefore essential, and they are easily fulfilled. For every photographer, who is not prejudiced, but sensible of the attractions of the art or science he cultivates, can experiment, see with his own eyes, and touch with his hands, the most surprising phenomenon his art can show."

The pictures sent by Dr. Sabattier excited much interest, and the thanks of the Society were awarded to him for his communication.

M. de Poilly exhibited to the Society a new system of apparatus, permitting the working of wet collodion without exposing the plate to light. He remarks that—

"Collodion, the basis of the photographic processes called *instantaneous*, has not yet received its full extension outside the operating room; hence it follows that a tent has hitherto formed an indispensable piece of photographic luggage.

"To be able not only to lessen the material, but also to simplify photographic operations, so that the merest tyro may operate with the same certainty as the experienced artist; to be able to operate without a dark room of any sort, as well at home as abroad—such are the advantages presented by my apparatus.

"Hitherto travelling photographers have been obliged to operate under tents, and to carry with them a load which it is not always easy to transport from place to place, or suitably dispose of at the scene of operations. With my system of apparatus, wherever the camera can be planted, my new dishes find their place, and the operations proceed mechanically, so to speak, and with remarkable celerity.

"To be able to operate without laboratory or tent, I have invented for each photographic operation a compound apparatus, in as many pieces as there are operations to perform in obtaining a picture. "*Sensitizing Apparatus*.—This is a bath employed in sensitizing the collodion film with nitrate of silver. Its form gives it many advantages over vertical and horizontal baths, without possessing any of their inconveniences. Thus, it requires only the liquid of an horizontal bath while the plate is covered with nitrate, as instantaneously as with a vertical bath, and this is done with the aid of a handle which suspends this bath under the base of the camera obscura, and admits of its turning, so as to assume the necessary positions:—1st, for introducing the plate; 2nd, for its immersion; 3rd, for draining it; 4th, for removing and conveying it into the slide; all without any loss of liquid, and without its having received any photographic light. In this and the succeeding operations the are not soiled, or stained by the solutions. This bath is suspended by its handle beneath the base of the camera, in an horizontal position; before immersing the plate it is placed vertically, and is fixed in this position by a hook. The quantity of solution judged necessary to introduce into the bath—a quantity which must never exceed that requisite for an horizontal bath—collects at the lower end of the bath. While it is in this position the collodion plate is introduced, the collodion side towards the operator; the bath is then shut, the hook unfastened, and the bath immediately resumes its horizontal position. The solution collected at the bottom of the bath covers the collodion plate in an instant. The bath is then rocked, to allow the ether to evaporate, and when the plate is supposed to be nitrated, the bath is again placed in a vertical position, and held there by the hook. The solution now flows to the bottom of the bath again, and the plate is found in its first position, which permits it to drain before being passed to the slide.

"*The slide*.—In this position the slide of the camera is adapted to the bath by the aid of grooves; this done, the slide and the bath are opened, and unhooked; the

whole revolves towards the operator. By this movement the plate places itself in the slide, and the liquid flows into the reservoir. The slide is then closed, the bath removed, and the plate is now ready for exposure in the camera. When it is desired to shut the bath hermetically, the vulcanized cover is screwed on, as in ordinary vertical baths.

Apparatus for Developing Baths.—Upon leaving the camera, the picture, as is well known, exists only in the latent state. I have therefore been led to construct a bath made so as to receive the plate from the slide, after its exposure in the camera, without its being attackable by the external photogenic rays; to develop and watch the appearance of the image in its different stages; and lastly, to wash it, and allow it to be withdrawn only after its complete appearance. Upon removing the slide from the camera, it is adapted to this bath by means of grooves, and the quantity of developing solution introduced requisite to cover the plate; the covers are then opened, and the plate slides into the bath. As soon as it reaches the bottom, it is rocked, as generally done; and upon opening the bottom of the bath, employing a reflector, and examining it by light admitted through a yellow glass, we follow the operation step by step. When satisfied with the result, the liquid is rejected; the picture is then washed, withdrawn from the bath, and fixed."

M. de Changy presented to the Society his new arrangement for positive printing frames.

These frames differ essentially from the ordinary ones, inasmuch as the screws and springs usually employed to press the negative and printing paper together, are suppressed. To replace these, the inventor has placed under each bar of the back of the frame four india-rubber springs, arranged perpendicularly to the bars, and which, by their elasticity, assure an equable, gentle pressure. In another system of frames, the bars, furnished with the same kind of india-rubber springs, are armed on their upper part with an eccentric lever, which, upon being turned, permits of the gradual exercise of a strong pressure upon the glass.

M. Stephen Geoffray communicated some observations upon the employment, as recommended by himself some years ago, of the iodide of carbon in the solutions of spirits of turpentine and of benzine, of which some photographers make use in the preparation of negative paper. This substance possesses great advantages, for it is soluble in these two vehicles, which the alkaline or metallic iodides are not.

The President, while recognizing that the organic iodides might be advantageously employed in this case, feared that M. Geoffray was in error with regard to the nature of the compound sold to him under the name of *iodide of carbon*, for hitherto the iodides of carbon have only been prepared in the laboratory.

M. Geoffray said, that the product in question was in the form of a yellow powder, slightly crystallized.

From this description the President thought it must be iodoform.

The President then reminded the Society, that on the 1st of May, 1863, the bi-annual Exhibition of the Fine Arts would be opened. Without being able at present to state what would be the conditions of this exhibition, the Committee of administration is already in a position to inform photographers that, according to the practice adopted in former years, the exhibition of the French Photographic Society would figure side by side with that of the Fine Arts. The President considered it his duty to invite the members of the Society to make their preparations at once, and unite all their efforts to represent the French Photographic Society worthily at this Exhibition, to which the best productions of foreign artists will be admitted.

THE PATENT ALBUMENIZED PAPER.

SIR.—I was somewhat surprised to see, from your last weeks "News," that our talented friend Mr. Sutton is about to

patent a process for the preparation of caoutchouc-albumen paper, when, from what I can learn as to his method of preparation, the system has been in operation amongst many eminent photographers for four or five years at least, and I believe was invented by my old friend M. Gaumé of Mans, who obtained a prize from M. Le Duc de Luynes, through the Société Photographique de France in 1857 or 1858, I remember not which year. M. Gaumé prepared his paper in a solution of gutta-percha, or india-rubber and benzole, and sensitized it in a bath which contained alcohol. Again, M. Durer, of Paris, used india-rubber solution regularly, and I believe, uses it now. Herr Carl Sholts has used it for several years, I am informed, and M. Von Monkoven, I believe, published a formula for the use of it three years ago. I have used a solution of gutta-percha since 1858, both in Paris, in New York, and in Bremen Haben, and now use it in England; and should you think my formula worth the notice of your readers, I shall be happy to send you the details in the course of a few weeks, as I do not hold with those narrow-minded people who would patent for self-gratification that which of propriety belongs to the whole photographic profession. I admire Mr. Sutton, and give him all honour for his valuable works and suggestions; but I cannot help expressing my extreme surprise and regret that he should seek to monopolize to himself the honour to which M. Gaumé is entitled, and the profits which ought to be the common property of the profession. With many apologies for the length of my letter, and the indifferent English in which, as a foreigner, I am compelled to express myself, I remain, yours most respectfully,
ANGELO BIANCHI.

Art Studio, Zetten Hall, 22nd December, 1862.

[The use of waterproof solutions for preparing photographic paper is not new; but, until the publication of Mr. Sutton's specification, we cannot state the precise amount of novelty it may embrace. We remember repeated occasions on which such preparations have been proposed; but there are none, so far as we know, which are precisely the same as that of Mr. Sutton. M. Gaumé, for instance, used gutta-percha prior to albumenizing; others have used gutta-percha, india-rubber, &c., without albumenizing. Regarding the right to patent such things, it is a wide and difficult question. Whilst we desire to see the utmost liberality in everything connected with the art, and are convinced that much of its progress is due to the prevalence of this liberality, we cannot overlook the fact that there are occasions when it is due to the experimentalist that he derive some substantial profit from his labours. Few men have contributed more valuable suggestions, appliances, and improvements in the art of photography than Mr. Sutton—few with so much liberality. And of this we are assured, that he would not willingly appropriate either the credit or the profit due to others. If it should turn out that the idea has been so far forestalled as to make the patent of doubtful validity, we believe Mr. Sutton would be the first to propose that his process should be given freely to the public. We shall be glad to receive practical details, and the results of any analogous process, and give them the utmost publicity.—E.D.]

PAPER PREPARED WITH GUTTA PERCHA.

DEAR SIR,—Being a constant reader of your valuable publication, I have received great advantages from your remarks and suggestions. I have practised the art, as amateur, for the last ten years, and I found that the great desideratum is good paper, without that high gloss which is obtained on albumenized paper. In that direction I have for some time made experiments, which seemed to me satisfactory; but I still postpone to make it public until I shall have obtained the opinion of others. I have shown some prints to photographers in the neighbourhood, yet I intended to wait till fine weather. Reading your last number, I was taken by surprise to see that Mr. Sutton has taken a patent for albumenized paper, by rendering the paper waterproof. This is just the process that I pursued. He does it

with india-rubber. I discarded it, finding that I obtain better results with gutta-percha. Having rendered the paper waterproof, I iodized and excite. The two proofs which I enclose I have finished in a very short time. They print quickly. I have only washed them in several waters for the space of a quarter of an hour, that you may see if they undergo a change by light and moisture. You will kindly make some remarks about it in your next number, if space permits. I beg you to pardon this hurried note, having been in haste for the post. If you find the paper of any value, I will continue to experiment, and will send you, by your permission, specimens. I beg you also to remark if it will infringe Mr. Sutton's patent-right.—Yours respectfully,

ALEX. ARNSTEIN.

Ambleside, Dec. 22, 1862.

[Our correspondent is experimenting more especially in the direction of Mr. Cooper than Mr. Sutton. If we understand him rightly, he proposes the use of gutta-percha or india-rubber in place of albumen; Mr. Sutton as a preparation for albumen. The prints enclosed are very pleasing, and we shall be glad to hear further from our correspondent. We do not think he is trenching at all on Mr. Sutton's patent-right. See note to a preceding letter.—Ed.]

BROMIDES IN COLLODION.

DEAR SIR,—I beg to correct a few errors in my letter of the 26th of July, published in your issue of the 26th September, and 13th of October, 1862, just arrived.

Page 467, column 1: "But Mr. Blanchard's experiments appear to have," &c., should be, "appear at first sight to have," &c.

Page 467, column 2: "to solve the question of increase of sensitiveness," &c., &c., and a third portion, "with iodide of cadmium, 3 grains," &c., should be, "with iodide of cadmium, 3 to 4 grains," &c.

Page 479, column 1: "introducing cadmium as a component of the iodiser, &c., and that inferiority increased with the increase of cadmium," &c., should be, "and that superiority increased," &c.

I hope you will give me space to make some further remarks on the present subject, and to record in your journal also, in a comprehensive form, the manner of my experiments.

A.—Cadmium Iodized Collodion.

1stly, Superior in durability and sensitiveness, and equal in chemical intensity, under iron development, to the same with pyro.

2ndly, Whether under iron or pyro development, superior in durability, sensitiveness, and intensity, than bromo-iodised collodion developed with iron or pyro, the superiority being reciprocally as the quantity of bromide present in the bromo-iodide.

B.—Iodide of cadmium, 3 grains, iodide of ammonium, $1\frac{1}{2}$ grains, compared with iodide of cadmium, 3 to 4 grains, bromide of ammonium $1\frac{1}{2}$ to 2 grains, both under iron development. The simply iodized collodion, superior in every respect to the bromo-iodized, reciprocally as the quantity of bromide present in the latter.

C.—The same with cadmium and potassium, but with somewhat modified results and proportions; for in the case of the bromo-iodized, there is the usual limit to the introduction of bromide, when of the potassium salt.

D.—And in all cases of like combinations between cadmium and ammonium, or cadmium and potassium, whatever the proportions, provided that the cadmium salt did not fall below half the total quantity used, the simply iodized-collodion was:

1stly, Superior in every way under iron, to the same under pyro development.

2ndly, Under pyro, superior to the corresponding bromo; under iron only, when the amount of bromide was large.

3rdly, Under iron, superior to the corresponding bromo; under iron, reciprocally as the quantity of bromide present.

Thus, the collodion, iodized only with cadmium, under iron development, stands first; and iodized collodion, with not less than half of cadmium in it, and with iron development superior to itself when under pyro development.

All these experiments, be it remembered, were made with one collodion, with a bath very slightly acid with nitric acid; developers, pyro and proto-acetate of iron. They were all conducted as carefully as possible, and the results recorded are those obtained from each collodion in its best serviceable condition, and this, a little reflection will show, can only be done by repeated simultaneous trials of all the collodions on one and the same subject every two or three days, or every day (the latter the best plan), taking the best results of each up to its deterioration, and over the whole period of experiment (as the highest attainable excellence), for comparative tabulation.

Only this method could enable me to tell, or rather ascertain, which collodion stood the longest without deterioration, which gave the best detail, which the most vigorous in action, and which the most sensitive, &c.

And this now brings me to record the result of other experiments, not, like the last mentioned, exactly intended to show the comparative merits of iodides and bromides under iron or pyro development, but to define the quality of the salts best suited for any one sample of collodion which may be required for early use, or be available in its least serviceable condition within a given time.

A universal iodiser, or one suited for all collodions of reputable manufacture, is compoundable of equal portions of cadmium and ammonium, or cadmium and potassium, preferring the former combinations from its greater durability and power of conferring intensity. From this, as a standing point, it is not difficult to determine, by a few trials, in reducing one salt or the other, the iodiser best adapted for any collodions against the day of requirement, whenever that may be; and we can defer the day, or shorten the period of ripening, by the knowledge that we can confer keeping properties by increasing the proportion of cadmium, or injure them by the augmentation of ammonium. The first defers the age of ripeness or sensitiveness, but gives it greater duration; the second accelerates the said age, but makes it temporary—the more temporary when the ammonium is used as a bromide instead of an iodide.

And now, with this information, we may compare any number of collodions differently prepared and salted, whether only iodised or bromo-iodised, and determine the degree of their respective nature, properties of sensitiveness, durability, density &c., and cultivate any one or two, or all of these properties in the subsequent manufacture of other collodions, when intended to be particularly salted, which is probably the plan followed by most manufacturers.

If, however, with such different samples of collodion, salted so as to put them in the best serviceable condition against a certain day, comparative exceptions were made to determine the qualities of the salts employed, it would be an error, something similar to Mr. Blanchard's, for the result would not be a solution of the questions of iodides and bromides, but simply a comparison of the different degrees of sensitiveness &c., of several collodions particularly salted, when in their best serviceable conditions—a matter particularly of importance to those who manufacture collodion.

A sensitive plain collodion, with decided organic reaction, is, I think, well adopted for rapid work. By reason of those organic reactions, the decay of the collodion will be rapid; but it is a great help to rapid work to be able to extemporise, at a moment's notice, as it were, in quantities suitable for temporary requirements, instead of having several pints of cadmium collodion ripening on their shelves, and which may not be available in their best serviceable condition when most needed.

With such a collodion a large quantity of bromide is admissible. As intensity accompanies organic reaction, the bromide can be made a regulator of it, although the

duration of the reduction effected will vary with the energy of the organic reactions, eventually yielding to the latter, and to the re-establishment of the density, and its increase.

As I suppose such a collodion—because of its not keeping well in its plain state, but sensitive while it did keep—to be made up in small quantities, and salted with ammonium and cadmium, the most sensitive combinations I know of, which stands next to cadmium collodion; which admits of the free use of bromide, and which can be modified in sensitiveness, and in its effect upon the said collodion by the increase of one salt or the other, I am led to infer that some such case has made successful operators believe that the presence of the bromide in large quantities has played the important part of sensitiveness, when indeed it was rather attributable to the combination, including an alkaline salt, to the excitation caused, and to the collodion having been employed while that excitation lasted.

If, however, the bromide was the cause of it, any bromide should answer; and if the bromide was ammonium, it should be replaced by bromide cadmium, and a trial given. If the collodion were fit to be salted with iodide and bromide cadmium conjointly, the sensitiveness would be deferred appreciably, although more durable when reached. But if not of it, insensitiveness and destruction of the collodion would ensue, I do not say it would be impossible to make a collodion fit for salting with equal parts of iodide and bromide of cadmium; this would, however, be making a collodion to salt in a particular manner, and it cannot therefore effect the result of my experiments, establishing that bromide causes insensitiveness in proportion to its presence. For the different iodised and bromo-iodised collodions, from one sample, were used by me throughout their various states of sensitiveness, past their age of ripeness, and into their period of deterioration, and the best results of each recorded. Nevertheless, I say that wherever bromide can be introduced it is an advantage, as regards the reduction of excessive density, and in its capacity for faithfully rendering foliage, &c.

But that it is impossible to work rapidly without the use of large quantities of bromide, is, in my opinion, an error, the dissemination of which will cause, and has caused, many disappointments. The system of parading success, and attributing it to particular causes which are not the whole truth, is, to say the least of it, disingenuous. If the rapid operators, instead of attributing their success to the use of large quantities of bromide, were to explain how their collodion was made, the treatment it should receive, and its properties of keeping &c., and give a detailed method of working, it would then be the whole truth, and nothing but the truth. Until this is done, which no one need expect, it behoves us to accept their statements and proofs with much caution, especially when the results of careful experiments and extended experience are opposed to them. For in your own columns you have recommended infinitesimal doses of bromide, improperly ridiculed by Mr. Sutton, while many eminent photographers reject the salt altogether. To the mass of beginners, it is as well to point out that the use of large quantities of bromide, on which rapid operators claim their success, has, doubtless, some favourable conditions in the collodion for its presence, and in such case is a necessity of the particular method of working adopted—not the resuscitation, or successful application of a long neglected principle, applicable under every ordinary circumstance. In other words, the practice is not a radical photographic, but local necessity; and that, whenever followed without a perfect knowledge of the working of the rapid operator, disappointment and failure are always possible.

The next mail will arrive a fortnight hence, and I hope to read the commencement of the discussion on this bromide and iodide question, and eventually the decision which will be arrived at by wiser heads than mine.—I am, yours truly,

AUGUSTUS WEBB.

Photographic Notes and Queries.

TO SECURE CLOUDS IN LANDSCAPES.

SIR.—As the desire for securing natural clouds and proper atmospheric effects in landscapes is now happily increasing, I beg to acquaint you with a small instrument which I have lately been endeavouring to construct for facilitating this object, and would feel greatly obliged by your opinion as to its probable utility, through the medium of your answers to correspondents, as you will be, no doubt, better able to judge than I am. In the case of instantaneous views, or those taken over water, where the horizon is a straight line, I suppose an excess of exposure may be given to the foreground quite easily, by the ordinary flap shutter; but in the majority of landscapes, where a much longer period of exposure is requisite, and the horizon is seldom a straight line, the light cannot well be cut off from the sky by these means, without the more elevated portions of the foreground suffering from want of exposure.

The small instrument I have constructed, with the view of remedying this evil, consists of a folding hood placed on to the end of the lens-tubes, in front of the camera, and carrying in front a frame filled with a number of small slips, which fit into each other in such a manner as to form a light-proof covering, and admit of sliding up and down with a small amount of friction.

To use this the operator has simply to put his lenses in focus, and while he is looking at the image on the ground glass, to run his finger along the tops of these slips, and gently press them down till they form such an outline as to exactly cut off all the light from the sky; and then, when the foreground has had sufficient exposure, the frame is removed out of the way, and an instantaneous exposure given over all the plate, just sufficient for the sky and clouds.

The outline these pieces make is slightly serrated, but that assists in softening off the light more gradually.

The light may be still more gradually cut off, if need be, by gently lifting up the frame, or turning it round some time, during the exposure of the foreground. As the latter part of the afternoon is the only time when I can attend to photography, and as this neighbourhood is always enveloped in mist and smoke at this season, I have not had an opportunity of giving this contrivance a fair trial; but such trials as it has got lead me to think that only conditions favourable for photography are required for success. The enclosed, which I certainly cannot call pictures, were taken in the evening, and are sadly blemished by mist, smoke, and wind. The foreground was exposed about a hundred times as long as the clouds. The contrivance could be combined with the instantaneous shutter, so as to form one instrument.

It seems to me to make a considerable difference to the foreground, especially with a prolonged exposure and compound lens, as it cuts off in such cases all the light from the sky during the exposure of the foreground. This difference is most striking when the lenses are pointed towards the sun. Even in that case all sorts of haloes seem to be prevented. Perhaps, in cases where there are no clouds to take, it might be found useful for improving the foreground of the picture, and producing a sky of any desired density, to admit of painting in clouds—or in the case of dry plates.—I am, sir, your obedient servant,

Bruce Castle, 29th December, 1862.

ALPHA.

[If we remember rightly, the late Mr. Scott Archer was in the habit of using a method of securing a short exposure to the sky by a method similar in principle but different in detail. A piece of paper was torn or cut, with an edge following the outline of the horizon. This was fixed in a frame inside the camera, in such a way as to screen the sky during the greater part of the exposure, and turned down or removed for a few seconds at the close, so as to give a brief exposure to the sky. The object is so good that we hail every effort to facilitate it with pleasure. If there be one purpose we have more steadily kept before us than another, during the last few years, it has been to aid in the abolition of the unmeaning patch of white paper which has so long done duty as a sky in photographic landscapes, to the destruction alike of atmosphere, breadth, or real brilliancy. The two examples enclosed very satisfactorily illustrate that the contrivance of our correspondent will admirably facilitate the production of natural clouds in conjunction with a foreground requiring long exposure.—ED.]

Talk in the Studio.

DISTRIBUTION OF MEDALS.—It appears that the medals awarded by the jurors in the International Exhibition will be delivered to the proper claimants, on personal application, at the Exhibition building. The following letter has been forwarded to medallists:—

Exhibition Building, South Kensington, W., Dec., 1862.

SIR.—I am directed by her Majesty's Commissioners to inform you that the medal which was awarded to you by the International jury will be delivered on presentation of this letter at the Jury Offices, Western Dome, any day before the 10th of January, between the hours of ten a.m. and four p.m. If you cannot yourself conveniently attend, any person whom you appoint to act on your behalf may receive the medal for you on presenting this letter, countersigned by you. This letter must be produced to ensure admission to the building at the Western Dome, Prince Albert Road, and will have to be left with Mr. Iselin, the secretary of the juries, as an acknowledgement of the medal having been delivered. The certificates of honourable mention will not be ready for delivery till a somewhat later day.—I am, &c.,

(Signed)

F. R. SANDFORD.

PHOTOGRAPHY AND THE LANCASHIRE FUND.—We have pleasure in stating that Mr. Meagher, Camera Maker, of Coppice Row, has forwarded to the Photographic Exhibition a very handsome and large trunk camera, which formed a chief attraction in his case at the International Exhibition. The price of the camera is £25, and he has requested the Secretary of the Society to devote the proceeds, when sold, to the fund for the relief of our distressed countrymen in Lancashire.

"PHOTOGRAPHY IN ITS APPLICATION TO THE MAGIC LANTERN EDUCATIONALLY CONSIDERED."—This is the correct title of the paper to be read by Mr. Samuel Highley, F.G.S., &c., at the meeting of the Photographic Society, on Tuesday evening next, at King's College.

M. ASSER'S PROCESS OF PHOTOLITHOGRAPHY.—We have been favoured by Mr. Toovey, of the firm of Simonon et Toovey, lithographers, of Brussels, with some very fine examples of M. Asser's process of photolithography. These for half-tone, far transcend anything of the kind we have before seen. Several architectural subjects are very fine, and one of a portion of the Town Hall, in Brussels, which was quite untouched, leaves little indeed to be desired. It is full of detail, with every gradation of half-tone down to the deep pure black of the shadows. In general effect it is strikingly suggestive of a drawing by Prout. There are also copies from oil painting, and life size head from a statue, with quite sufficient half-tone for the subject, and is wonderfully bold and fine in drawing. An excellent effect is produced in some by printing in, with a separate tint, a sketchy suggestive sky; in others there are the graduated tints from warm brown to the blue sky, which gives to some Egyptian scenes from rather hard negatives an exceedingly fine effect. M. Asser adheres in the main to the formula described in his specification. For reproductions starch and abichromate are used, for negatives from nature, requiring the preservation of half-tone, a paste of wheaten flour with bichromite is used. It is probable that some specimens will be exhibited at the forthcoming exhibition of the Photographic Society.

To Correspondents.

CORNISH CLOUGH.—You will find information on the subject of magic lanterns in many of our back numbers, we may especially mention Nos. 84, 87, 88, 89, 90, 126, 127, and others. Perhaps 126 will answer your purpose best. Photographic slides and other apparatus for the lantern you may doubtless procure of Bland and Co., Horne and Thornthwaite, Murray and Heath, Cox, Samuel Highley, and others.

VAISSIER ET VÉREY.—We have enquired of Mr. Fry as to his yellow glass, and have received confirmation of our remarks last week. The dealer happened to have a sample of yellow glass, which proved non-actinic; but has not been able to supply with certainty subsequent applications for the same article.

T. M. LEAHY.—In speaking of paper prepared with the resin of silver, Mr. Cooper means, as you conjecture, paper prepared with the resin, without chloride, and then floated on the silver solution. We have been much interested in your experiments with ammonia. The ALMANAC was sent.

HAYFORDWEST.—Benzole will dissolve a coating of india-rubber from glass. Probably boiling water and friction will make it peel off. 2. So far as our own experience is concerned we prefer the tannin and honey dry plates to any others; except, perhaps, the collodio-albumen, and they are more

troublesome to prepare. Perhaps the best mode of washing is that practised by our American correspondent. He uses six dipping baths, removing the plate from one to another, after remaining long enough in each for the coating, &c., of another plate. Sufficient washing to prevent stains is thus secured without much trouble. 3. There may be some danger of unequal sensitiveness in Mr. Keene's method, but we cannot say with certainty, as we have not yet had the opportunity of trying. We are glad to hear you find the NEWS so useful, and thank you for the additional subscribers you have secured for us.

JAMES STODDARD.—Where Mr. Warner has not given a formula, he is doubtless referring to that already given by Mr. Cooper, on page 537, Vol. VI., of the PHOTOGRAPHIC NEWS, which stands thus:

Pure frankincense	10 grains
Mastic	8 "
Chloride of calcium	15 "
Spirit	1 ounce.

We do not understand Mr. Warner as proposing any new proportions, but describing the method of manipulating, which in his hands has been successful.

AMICUS.—Mr. Osborne's papers on photolithography appear in Nos. 214 and 221 of the PHOTOGRAPHIC NEWS, pages 481 and 570 of Vol. VI. A notice of Col. James' system of photopyrography appears on page 164 of the same volume, or No. 187. It is based on the same principle as photozincography and photolithography, but the transfer itself is used to print from instead of putting it on stone or zinc.

J. SCRITA.—The streaky background arising from a new bath we have generally found to disappear on neutralizing, sunning, and adding sufficient acid. Sometimes the presence of actinic light in the dark room will cause such streaks. We have known such streaks disappear after using the bath a short time; and sometimes we have found the addition of a little tincture of iodine to the collodion sufficient to remove them. Moving the plate laterally whilst in the bath, will sometimes prove a remedy; and sometimes changing the position of the plate, immersing it cross-wise when about half-excited in the vertical position. Try these remedies, and use the bath a little. It is a pity to put the bath aside as useless when it is working so well in other respects.

A LADY AMATEUR.—You will find full instructions for recovering the silver from hypo baths, &c., on page 50 of our fifth volume, or No. 126. Any gold remaining in old toning baths may be precipitated as dark powder by adding solution of proto-sulphate of iron, the quantity or strength is unimportant, so long as you add until no more precipitate is thrown down. The brown powder may be converted into chloride of gold by dissolving in *aqua regia*.

C. P. W. states that on his albumenized paper, excited on a 100-grain silver bath (ammonia-nitrate, or rather oxide of silver dissolved in nitrate of ammonia) when hung up, the silver solution collects in drops as if repelled by the paper. We have never met with such a difficulty, and cannot well understand it; possibly the paper has not been floated sufficiently long to form the proper combination; possibly too much nitric acid has been added to the bath. Possibly the paper is defective in some way, or has been handled and become greasy.

C. F. W.—We have no means whatever of knowing whether the advertisement in question is *bona fide* or not. 2. So far as we can ascertain, the lenses of the maker referred to are very variable, some good and some bad. We prefer the last-mentioned as being most trustworthy. 3. Portraits can be taken with a view lens, but it is not the best instrument for such work.

C. W. S.—You will be able to obtain all information of Mr. Alfred Harman, 3, Albert Cottages, Hill Street, Peckham, the Secretary. The next meeting is held at the City of London College, Leadenhall Street, on the evening of Thursday January 8th, when, if you choose, you can attend. We shall have pleasure in proposing you.

D. WESTON.—We are not sufficiently familiar with the lenses of any of the makers you name to speak with certainty of their qualities, or advise you satisfactorily. We believe the first mentioned permits buyers to test the lenses, an arrangement which ought to lead to satisfactory results. Whether the others do so or not we do not know.

T. A NEW SUBSCRIBER.—We regret that we cannot charge the back numbers at a reduced price. Many of them we will willingly pay full price for ourselves. The figures are accidentally omitted, you will find them, however, half a dozen lines above. 2. The printing process used by Mr. Fontaine in his printing-machine is that by development. The paper is prepared with an iodide and bromide, and a condensing lens is used to concentrate the light. By these means instantaneous or very rapid printing is not impossible.

J. H.—The enlarged prints from America, exhibited at the meeting to which you refer, were printed on ammonia nitrate paper. We were not present ourselves, and did not see them, but we learn from trustworthy authority, that they were very poor indeed. We have not yet heard particulars of Mr. Stuart's new apparatus, but the prints he has already produced by the old one, are, as nearly as possible, perfect.

NOTICE.—A good glass positive cannot be converted into a good negative. If it be good as a positive, it will be insufficiently exposed for a negative. Negatives may be produced by means of iron only, but not always so conveniently as with pyrogallic acid intensifying. A collodion, giving a somewhat dense image, developed with acetate of iron, is frequently sufficiently dense, without further intensifying. Varnishing is only necessary for the protection of the negative. If it have been well washed, and the exciter paper be quite dry, no danger arises from the two surfaces coming into contact. If the paper be damp, however, a brown stain may result, especially if the slightest trace of hypo remain in the film. Varnishing is always safer, but where one or two prints only are required, it may be dispensed with.

A PRINTER.—If clouds are well painted at the back of the negative, or if they be well printed in separately, we think they are quite permissible. We have often said that in such subjects success is the touchstone of legitimacy. It is only when the thing is badly done that it challenges criticism. The object is to produce really good pictures; this done, the means will not often be challenged.

Several correspondents in our next.

All Letters, Works for Review, and other Communications for the Editor, should be addressed to the Office, 32, PATERNOSTER ROW, LONDON.

THE PHOTOGRAPHIC NEWS.

Vol. VII. No. 227.—January 9, 1863.

PHOTOZINCOGRAPHY.*

THE work of Col. James and Captain Scott, on photozincography, is one of the most interesting books which have been published in connection with the art, not simply as a complete and detailed statement of the processes and formulæ used at Southampton, but for the variety of fine reproductions in printer's ink with which it is illustrated.

Referring to the latter first, we are enabled to endorse the opening remark in Col. James's introduction, as to the high state of perfection to which these processes have been brought at Southampton. For reproduction of engravings and similar subjects, we have before said, that both the process of Col. James and that of Mr. Osborne have reached a pitch of excellence which leaves little to attain or desire. Amongst the dozen photographic illustrations given in this book are exquisite copies of engravings, some of which have a great deal of fine, close work, which is most perfectly rendered. We may mention amongst these a reduced copy of a fine engraving from a painting by Raffaele; two of Piranesi's engravings of antique vases of rare design; and a reduced copy of one of Volpato's engravings of a panel in the Vatican, painted by Raffaele. There are also fine specimens of hill shading, and fine detail in maps; a reduced copy of an indenture; a page of Domesday Book; and a page of the folio edition of Shakespeare of 1623. Each of these are perfect illustrations of the value of the art for the several kinds of work represented.

The technical details of the work will be read with much interest and attention amongst photographers. The processes are divided for clearness into three parts. These consist in the production of the negative; the preparation of the positive photographic print in greasy ink; and the transference of the print to the surface of the zinc, or to stone, and the preparation of that surface for printing. These processes are here more fully described than in any previous work, and a brief *résumé* will doubtless be interesting to our readers.

It must always be borne in mind, that the negative most suitable for giving good results on the lithographic stone, is one perfectly dense in the whites of the picture, and quite clear and transparent in the blacks; in short, great brilliancy, intensity, and freedom from any trace of foggy deposit on the shadows, and as in engravings, maps, &c., the gradation is secured by the artificial means of lines, hatching, or stippling, the gradation known by photographers as half tone, is not required in the pictures.

The collodion used is simply iodized, and is preferred about a fortnight old. The formula given stands as follows:—

Pyroxyline	80 grains
Iodide of cadmium	15 "
Iodide of potassium	75 "
Alcohol sp. gr. 812	10 ounces
Ether sp. gr. 725	10 "

The usual silver bath of from 35 to 40 grains to the ounce of water is used, slightly acid with nitric acid, in preference to acetic acid.

* On Photozincography and other photographic processes employed at the Ordnance Survey Office, Southampton. By Captain A. De C. Scott, R.E., and the direction of Col. Sir Henry James, R.E., F.R.S., &c. London: Longman & Co.

The development is effected by iron. The formula stands thus:—

Protosulphate of Iron	1 ounce
Glacial Acetic Acid	6 drachms
Alcohol	6 "
Distilled Water	1 pint.

The image is sufficiently developed by means of this solution, especial care being taken to stop its action before there is the slightest trace of deposit on the fine lines or shadows. Further intensity is then secured by the application, after fixing, of pyrogallic acid, a grain and a half to the ounce, twenty-four minims of acetic acid, and a few drops of a solution of silver. If further intensity be required the negative is immersed in a weak solution of bichloride of mercury until its surface is whitened; it is then treated with a weak solution of hydrosulphate of ammonia, which gives the required density. To prevent lateral deposit filling up the fine lines, the last process of intensifying is effected after the plate has been suffered to dry, the edges being varnished to prevent the film slipping.

The apparatus used for convenient copying was fully described in the PHOTOGRAPHIC NEWS, Vol. III., and we do not find that any material alteration has been made except in the adoption of Dallmeyer's triple achromatic lens for copying.

To produce the transfer the paper must be hard, thin, and tough, of even texture, and free from woolliness, and but slightly sized. Paper made from linen is most suitable; the best results have been obtained with the ordinary bank post paper, slightly sized. The proportions of the bichromate and gelatine—gum has long been abandoned—vary with circumstances. It is necessary that the solution of gelatine be fluid at a temperature of 100°, and that the proportion of bichromate be sufficient to render the whole of the gelatine insoluble under the action of light, but no more. The quantities here stated are two ounces and a half of bichromate of potash dissolved in ten ounces of hot water, added to three ounces of gelatine, dissolved in forty ounces of hot water. The fluidity is maintained by placing the dish containing the mixture in another containing hot water. The paper is floated for a few minutes, and when dried, the process is repeated. When again dry it is passed through a copper-plate press, on a hot steel plate.

The time of exposure to the negative varies, from one minute in the sun, to twenty minutes in dull light. When sufficiently exposed, the blacks appear of a brownish green.

The transfer ink, is made as follows:—two pounds of chalk lithographic ink, and one pound of middle linseed oil varnish are ground together; four ounces of Burgundy pitch are melted in an iron vessel, and to it are added two ounces of palm oil, and two ounces of white wax; these are well stirred together on the fire until they begin to burn. The ink and varnish, first mixed, are then added, and the whole thoroughly incorporated.

For use, a portion of this is thinned with turpentine to the consistency of thick treacle. To apply this ink to the surface of the print, a zinc plate or lithographic stone is inked in the usual method with a roller; the bichromate print is then laid face down, and passed through a lithographic press. By this means the whole of the surface is covered with a uniform surface of ink.

To remove the ink from every part but the image, the print is floated for five minutes on water at 90° Fah. back

downwards. It is then laid on a porcelain slab, and the surface rubbed gently with a soft sponge dipped in gum water. This will remove the unaltered gelatine, and, if all the other operations have been rightly performed, a perfect positive image in printer's ink remains. This, when dry, is ready for transferring to zinc or stone.

The zinc plate is, of course, prepared to receive the transfer; this is effected by first smoothing it, and then giving it a grain by means of fine sand and muller. The surface so produced has an affinity for the greasy ink somewhat similar to that of the lithographic stone. To effect the transfer the print is placed for a minute or two between two sheets of damp paper, and then laid on the prepared zinc plate, and passed through the lithographic press. This done the print is moistened on the back, which causes the ink to leave it the more readily. On removing the transfer paper, the image is left in the transfer ink on the zinc plate. It is now etched, as the next process is termed, by means of a mixture of gum-water, phosphoric acid, and a decoction of galls. Four ounces of Aleppo galls are steeped in three quarts of water for a day, and then boiled. One quart of this is added to three quarts of gum-water about the consistency of cream, and three ounces of a solution of phosphoric acid. To prepare the latter, some sticks of phosphorous are placed in a pint bottle, not quite full of water; a hole is made through the cork to admit air; this acting on the phosphorous, which projects above the water, produces oxidization, and the water dissolves the phosphoric acid as soon as it is formed, and in a few days produces a solution strong enough for use. The etching liquid is poured on the plate, and allowed to remain from twenty seconds to a minute, fine work requiring a shorter time than coarse work. The plate is then washed with water, and dried.

The transfer ink is next removed from the plate with turpentine, or with a mixture of turpentine, olive oil and gum water. It is then rolled up with printing ink, and is then ready for use.

In the process which Col. James has termed *Photopapyrography*, the image obtained in greasy ink, on paper prepared with gelatine and bichromate, instead of being transferred to zinc or stone, is used to produce one or more positive impressions on paper, by passing it through the lithographic press. The negative should be in such cases reversed, either by being taken through the glass plate, or by means of a reversing mirror or prism.

For the reproduction of manuscripts, printed matter, &c., the use of negatives obtained, by wet collodion on paper instead of glass is recommended. The sensitiveness is stated to be superior to that of wet collodion on glass; and when waxed it yields excellent results. With such negatives the image need not be reversed for photopapyrography, as there will be but an inconsiderable loss of sharpness in printing through the paper.

The volume contains an interesting account of the rise and progress of the application of photography to this branch of the public service, and of the discovery of photozincography. It is unnecessary to revive any discussion on the subject here. Different steps in the discovery were probably due to different individuals in the establishment, who have, from time to time, received due acknowledgment. The general control, the suggestion, direction, or permission, have rested with Colonel James, and photozincography very naturally receives public recognition as his process.

Since the publication of this book, Colonel James, as our readers know, has devoted some attention to the production of half-tone, an accident having suggested the means, in a certain condition of the prepared paper, produced by keeping it a few days before use. The several specimens, with which Colonel James has favoured us of the results, have been full of promise. There is unquestionably abundance of half-tone, the fault at present existing being rather a want of deep blacks for the shadows, or a want, perhaps, of perfect gradation generally. Sufficient is, however, already produced to indicate the possibility of obtaining

photolithographs with proper gradation of half-tone, pure lights, and deep shadows. This possibility has frequently been doubted, on the ground that gradation in lithography could only be obtained by artificial or conventional means. We find enough done to convince us that more may be done, and we have pleasure in learning that Colonel James is prosecuting his experiments in this direction.

We have before stated, that by far the best photolithographs we have seen, as regards gradation of tone, are some done by Asser's process. In these, instead of gelatine or albumen, a paste of wheaten flour is used with the bichromate. The precise condition of the organic matter in combination with the bichromate, seems materially to affect the question of half-tone, and suggests a direction for experiment. A specimen we received from Col. James, produced by the bitumen process, which has recently been vaunted as giving half-tone, was a lamentable illustration of the worthlessness of that method, as the print is almost entirely destitute of any qualities which could give it value, and strikingly enforces the fact, that the process is entirely superseded by the method of transferring now in successful use.

PHOTOGRAPHIC CHEMICALS:

THEIR MANUFACTURE, ADULTERATION, AND ANALYSIS.

Alumina Salts.—The salts of alumina are only of indirect interest to the photographer; we shall, therefore, give but a brief sketch of their history. The earth itself is a white powder, tasteless and inodorous, and after ignition insoluble in most acids. It may readily be prepared in the hydrated state, by adding an excess of ammonia to hydrochlorate or nitrate of alumina, and thoroughly washing and drying the gelatinous precipitate. If alum is used, the resulting hydrate is contaminated with sulphuric acid. Alumina has less affinity for acids than any of the bases we have yet mentioned, and forms with them compounds which have little stability. They are decomposed sometimes by simple ebullition, and deposit hydrate of alumina. When the earth is precipitated, either in this manner or by the addition of an alkali, it has a remarkable tendency to carry down with it organic, and especially colouring matter, which may be in solution; many kinds of inorganic impurity, commonly classed under the generic term mud, or dirt, are also carried down and removed from solutions in this way. This property of alumina is applied to great use in the arts and manufactures. The colour-maker utilizes it in the preparation of lakes, by precipitating alumina in the presence of some brilliant organic dye; and it is frequently used also for the purpose of decolorising solutions. Recently precipitated alumina has a similar property. When put into a liquid containing organic colouring matter, it almost invariably attracts this to itself, becoming tinted with the particular colour, whilst the solution is rendered almost colourless. The dyer and calico printer avail themselves largely of this property. When cotton goods are placed in a solution of a colouring matter, they refuse to fix the substance, and do not take the colour in the same way as silk or woollen goods would. The manufacturer, therefore, employs the artifice of precipitating alumina into the cotton fabric before immersing it in the colouring solution. Upon now dipping it into the coloured bath, the alumina, acting as a mordant, causes the goods to take the dye readily.

Chloride of Aluminium.—This salt has recently become of considerable commercial importance, being the starting point in the preparations of the metal aluminium. It is, like many other chemical compounds, very difficult and tedious to make on a small scale, although attended with no difficulty when prepared as a manufacturing operation. When alumina is dissolved in hydrochloric acid, it may be assumed that the solution contains chloride of aluminium; but upon evaporating the liquid to obtain this body in the solid state, a residue is left containing chloride of aluminium with the elements of water; and upon further increasing the

heat, the water is decomposed, its hydrogen uniting with the chlorine to form hydrochloric acid, which goes off, and its oxygen uniting with the aluminium to form a residue of alumina. It is not possible to avoid this decomposition, except by setting to work in a somewhat round-about way. An intimate mixture of alumina and carbon is prepared by thoroughly incorporating together alumina, powdered charcoal, sugar, and oil, to the consistence of a thick paste. This is introduced into a crucible, and heated, out of contact with the air, to redness. The sugar and oil are in this manner decomposed, and the carbon of their composition is left in a state of intimate mixture with the alumina and powdered charcoal. The mass is introduced warm into strong porcelain or glass retorts, through which a slow current of perfectly dry chlorine gas is allowed to pass. When all the air has been swept from the apparatus, heat is applied to the carbonized mass, when the alumina is decomposed by virtue of the double chemical persuasion to which it is subjected: the carbon takes the oxygen from the alumina, forming carbonic oxide, whilst the chlorine unites with the aluminium to form chloride of aluminium. This is carried along by the carbonic oxide gas, and condenses principally in the form of a fine powder, and partly as a solid mass at the extremity of the neck of the retort, which must be very large, or it will be stopped up by it. The alumina must be precipitated from a solution which contains no sulphuric acid, as otherwise the alumina will carry some of this down with it, and will give rise to the formation of chloride of sulphur, which will mix with the chloride of aluminium. Chloride of aluminium forms a lemon-coloured waxy mass, transparent, and of a crystalline texture resembling talc. It fuses when in large masses, a small quantity immediately evaporating on the application of heat; it boils at about 360° Fah., and fumes slightly in the air, smelling of hydrochloric acid. It rapidly deliquesces in the air, forming transparent drops, and dissolves in water with a hissing noise and evolution of heat. In this state it has fixed to itself the elements of water which cannot be driven off again by heat, the compound splitting up, as we have above described, into hydrochloric acid and alumina. When the anhydrous chloride of aluminium is heated with potassium or sodium (the latter method is always employed at the present time), metallic aluminium is separated from it with formation of chloride of potassium or of sodium. If the aqueous solution of chloride of aluminium, or the liquid obtained by saturating hydrochloric acid with hydrate of alumina, is allowed to evaporate in a warm and very dry atmosphere, crystals are deposited, which are very deliquescent, and very soluble in alcohol. They contain twelve atoms of water of crystallisation, and 43.96 per cent. of chlorine. This salt has not been much used in photography; but since chlorides which are very soluble in alcohol are not very common, it is likely that chloride of aluminium could be employed for several useful purposes, especially in the collodion process.

Nitrate of Alumina.—This is a very deliquescent salt, formed by saturating nitric acid with hydrate of alumina. Upon evaporating the solution carefully down to a syrupy consistency, and allowing it to stand in a cool dry place, the nitrate crystallises out in thin colourless laminae. It has been successfully applied, like nitrate of magnesia, for the preservation of sensitive collodion plates.

Sulphate of Alumina and Ammonia, or Ammonia-alum, as it is generally called.—This is the most important salt of alumina, and is prepared by hundred of tons at a time. Alum shale is boiled out in dilute sulphuric acid, and the solution is mixed with sulphate of ammonia derived from the gas residues. The solution is boiled down rapidly, and the salt is deposited in the form of a fine white crystalline powder, known by the name of alum meal. This is rinsed from the impure mother-liquor by a small quantity of water, then dissolved in hot water, and allowed to crystallise in large wooden tubs, capable of holding some tons' weight at a time. After the magnificent display of alum which our

readers have recently seen at South Kensington, no detailed account of the appearance of this body is needed. Although called alum, this name strictly speaking, belongs to potash alum, a compound exactly similar to the one we have now been describing, but containing potash instead of ammonia. Until within the last few years, potash alum was always made. It was found, however, that ammonia, which would confer equally good crystallising powers upon the alumina salt, could be obtained in almost unlimited quantities from the gas-purifying liquors; and it has, therefore, so completely replaced potash alum, that it is a difficult matter to obtain even a small specimen of the latter compound.

PHOTOGRAPHY AND THE HEALING ART.

[We are desirous of giving especial prominence to the appeal of Dr. Wright to photographers. No more interesting or important application of photography can be made than that which makes it an adjunct to the art of healing. A collection of good photographs of all kinds of medical and surgical cases, placed in the library of the Medical and Chirurgical Society of London, cannot fail to be of the utmost value in aiding the study of such cases. We feel sure that any of our readers possessing negatives, prints from which will add to the completeness of the collection, will gladly respond to the appeal of their brother photographer, our friend Dr. Wright.]

SIR,—Physicians and surgeons desirous of retaining lasting representations of important cases (on the accuracy of which might depend decisions as to life and death in similar cases occurring to others) were formerly compelled to resort to the pencil of the artist. But the reliable talent available for such a purpose was not readily procured, and when obtained involved a large expense. The photographic art supplies a simple and cheap method of perpetuating the appearance presented by any particular form of diseased structure at any stage of its progress, or of its cure, and medical men are daily more and more availing themselves of the opportunities thus presented. It took hours to make an exact sketch where now it requires only as many seconds, and the presentment of that seen is not only accurate in every detail, but gives facilities for such comparative measurements as the hand following the eye would never have obtained. Hence it follows that photography has been of vast service in this department of its working, and there is scarcely a professional photographer who has not been called on, at some time or other, to picture the appearances produced by deformity or disease, or to perpetuate some triumph of surgical skill. Such records are of lasting value; they do not tell merely of that which they represent; they also afford assistance, such as no verbal description could supply to those who may be in doubt when similar cases occur. Hence it well may happen that the exact verisimilitude which a photograph affords will determine doubts on which the issues of life and death may depend.

Photography is, *par excellence*, an art of exactitude, it neither exaggerates, or mitigates what the eye of the camera sees, and therefore is practically reliable even where so much depends on its evidence. The importance of the photographic representations of professional subjects has led the Medical and Chirurgical Society of London to determine on adding to their extensive library a collection of photographs of subjects of professional interest.

As a Fellow of the Medical Chirurgical Society, and a Member of the Council of the Photographic Society, I have willingly undertaken to gather and arrange the contributions. In the hands of professional and amateur photographers in various parts of the kingdom are numerous negatives, for the most part taken at the request of medical men. I believe, that considering the object in view in making this collection, I am justified in asking your readers

to supply me with prints from any such negatives in their possession—of course unmounted—with a few words of reference to the case so photographed, or to the medical practitioner for whom it was taken.—I remain, yours obediently,
H. G. WINGRUP, M.D.

23, Somerset Street, Portman Square.

Critical Notices.

THE PHOTOGRAPHIC NEWS ALMANAC; or the YEAR-BOOK OF PHOTOGRAPHY for 1863. London: PHOTOGRAPHIC NEWS OFFICE, 32, Paternoster Row.

FOR very obvious reasons, our notice of the YEAR-BOOK OF PHOTOGRAPHY for 1863 must be confined to a simple description or statement of its purpose and character.

In the ALMANAC for the present year we have aimed at greater comprehensiveness than on former occasions. We have in each year's issue endeavoured to give, in addition to the various memoranda likely to be interesting in a Photographic Year-Book, a *résumé* of the definite discoveries of the past year. But this is by no means an accurate or complete register of the advancement of the art; much of the most valuable progress consists in improvements arising out of the cumulative experience of able men, by steps so gradual, that they cannot easily be defined and set down. A record of such improvements is, nevertheless, of the utmost interest and importance to the student striving after perfection, and we have, therefore, availed ourselves of the facilities we possess of becoming familiar with the practice of the ablest photographers of the day. Guided by the information thus gained, and our own experience, we have given a re-statement of the most important processes, embodying all minor improvements, as they are successfully adopted by the best men of our time. It will be seen that our YEAR-BOOK thus becomes, not simply a collection of scraps or memoranda, but a manual of improved practice for general reference.

A simple statement of the principal contents will, perhaps, be the most satisfactory notice. Of course, there is the calendar, and usual general information of an almanac. The days of meeting, exhibitions, and officers of the various societies are given. A briefly detailed statement of the annals of photography for the past year follows. Then, under the head of Photographic Processes and Formulae, a complete statement of the wet collodion process, including the manufacture of collodion; the preparation of the silver bath; development and developing solutions; modes of intensifying, &c., &c. A chapter follows, containing a brief statement of authenticated formulae communicated by various first-rate photographers; amongst whom we may name T. R. Williams, Southwell Brothers, H. P. Robinson, and others. A chapter on the construction of glass-rooms and lighting the sitter will be found useful. A chapter on instantaneous photography contains a communication on the subject written by Mr. Blanchard for the work. Methods of printing, toning, and fixing follow, with chapters on printing on silk, on resinized paper, on double or fancy printing, &c.; chapters on mounting, on glass positives, on portraiture and card pictures, on enlarging negatives, on the solar camera, &c., follow. The department assigned to "Processes and Formulae," is completed by a series of short chapters devoted to the Dry Collodion Processes, containing the Collodio-albumen Process as practised by Mr. Mudd; the Tannin Process; the Tannin and Honey Process; the Fothergill Process; Dry Collodion without Preservative; a Valuable Preservative Process; Instantaneous Dry Plate Photography; and Modes of Developing Dry Plates.

The "New or Modified Processes" of 1862, are then briefly stated; amongst these will be found: a New Alkaline Dry Process; the Morphine Dry Process; a Carbon Process; Improved Iron Developer; Photography in Natural Colours; Alcolene, or Collodion without Ether; a New Photographic Varnish; Mode of Preventing the Discolouration of the

Nitrate Bath; Formic Acid in the Developer; Mr. Sutton's Rapid Dry Process; Mr. Keene's Rapid Dry Process; Photography on Gelatine; Fumes of Ammonia in Printing; &c., &c. A variety of useful tables, a recapitulation of new apparatus, &c., a list of photographic patents during the year, the New Copyright Act, with instructions for the registration of photographs, and some other matters complete the work, the whole constituting, as we think our readers will agree with us, a very comprehensive photographic *vade mecum*. The YEAR BOOK contains something like twenty pages of matter more than on former editions, but the price remains as formerly, one shilling.

THE COLLODION PROCESSES, WET AND DRY. By THOMAS SUTTON, B.A. London: SAMSON LOW & SON.

FEW men have the art of explaining themselves more simply, and writing more directly to the purpose, than Mr. Sutton, and, as few men have a better knowledge of photography, he could not fail to produce a good book on the subject, and one which every photographer should read.

The work before us contains a very complete and lucid statement of the wet collodion process, from the manufacture of the pyroxyline to the varnishing of the negative; a general description of the dry processes, and details of the tannin process, the collodio-albumen process, and the rapid dry process, recently published by the author; together with chapters on instantaneous photography, positive printing, chemicals, apparatus, &c. Each of the subjects is treated with a simplicity, and freedom from ambiguity, which is quite refreshing, and in the best possible style for an instruction book. The chapter on the manufacture of pyroxyline, is an especially valuable one, giving a clear idea of the principles involved, and describing formulæ which, worked with anything like care and attention, will yield an excellent soluble cotton, without risk of failure.

We like Mr. Sutton best in his description of manipulation, &c., there he is unsurpassed in the happy homely simplicity, and graphic force of his style. On some points of theory and practice, as our readers know, we do not agree with him. Although with modified force, he still depreciates the value of the bromides in wet collodion, regarding them only as the succedaneum for pure chemicals and good manipulation. In the dry processes generally, however, the importance of a large proportion of bromide is enforced, as essential to rapidity. We cannot entirely agree with him in his unqualified condemnation of commercial collodions advertised, as being "improved by age." Most photographers are familiar with the fact, that some collodions, especially if iodized with cadmium, do improve or ripen with keeping. The term "unchangeable," as applied to collodion, is probably untenable, as that implies stability for an unlimited period. We have in our possession however, collodion, we made three years ago, which we shall employ as a standard, by which to test other samples, and we rarely find any excel it in sensitiveness, whilst in cleanness and brilliancy it is rarely rivalled. The principle of manufacturing collodion and other preparations by published formulæ, to enable intelligent photographers to understand with what they are working and what reactions they may expect, which Mr. Sutton is enforcing when condemning the said advertised collodions, is one which cannot be strongly commended, and we believe that the manufacturer would in no case be a loser by such publication. We had marked some portions for extract, but the pressure on our space forbids their use at present; we shall probably give them on some subsequent occasion. In the meantime we commend the work to all our readers.

HARMONIOUS COLOURING AS APPLIED TO PHOTOGRAPHY. By an ARTIST-PHOTOGRAPHER. Fourth Edition. London: James Newman, Soho Square.

THE fact that four large editions of this work have been called for in four years, is a strong argument for the excel-

lence of the book, and the appreciation in which it is held by photographers. It is also a satisfactory illustration of the fact that photographers generally are interested in a work which, besides containing technical instructions in the art of applying pigments, is also full of hints on the application of art principles to photography, for we can scarcely suppose that there are many thousands of professional or amateur colourists, or that all who have bought the book, have done so simply for the purpose of learning to colour.

The new edition contains, not only full instructions for every mode of colouring photographs, but a very lucid statement of the general principles of harmonious colouring, and of the application of those principles to photography. Fresh chapters are added on the retouching in crayons of enlarged pictures, and also in colouring such pictures in pastel. A very useful chapter, containing "A Few Words on Portraiture," ought to be read by every photographer, and especially by those engaged in the production of card pictures.

COMPOSITION AND PROPERTIES OF GUN COTTON.

BY AUG. TESTELIN.

PYROXYLINE does not appear to be a chemical combination, in definite proportions, of cellulose with the oxygenic elements of nitrogen; it appears to us too variable in its composition and most essential properties, not to appear rather a physical modification, effected by condensation more or less considerable and perfect of a nitrogenous gas, which appears to be the protoxide of nitrogen.

In our opinion, the capillary fibres of the ligneous substance operating upon these gaseous elements by an attractive action comparable, in some measure, to the catalytic force of the cellular interstices of carbon, platinum, sponge, and many other bodies, which present this peculiar property of condensing certain gaseous bodies, without in any way uniting with them, and permitting the disengagement of these gases by the action of influencing causes more or less energetic.

Cotton, after undergoing the operations which transform it into pyroxyline, undergoes no change in its physical properties; still, in the generality of cases, it becomes less soft to the touch, and appears considerably disaggregated. But a remarkable phenomenon presents itself in this product, which is, that it has assumed an extremely singular passive condition, which renders it unattackable by chemical agents as powerful as concentrated sulphuric acid, nitric acid, potassa, and most other substances which completely destroy organic matters.

These different properties appear to us to be due to the fixation of a considerable quantity of protoxide of nitrogen in the organic cells, which exercise, like all capillary interstices, a powerful influence upon certain gases, which they condense and solidify, becoming at the same time inaccessible to the influence of other bodies, with regard to which the modified substance becomes less attackable, and then establishes itself in a truly passive state, by a cause analogous, so to speak, to that which produces a similar phenomenon upon iron and other bodies.

But when a more intimate cause comes to penetrate these spaces of the ligneous matter to destroy their cells, and dilate the gas which their attractive power concentrates, then the latter, spontaneously resuming their primitive normal state, *i.e.*, an infinitely larger volume—by breaking the cells which still form an obstacle, and the provocative force acting only upon a point—the vigorous action resulting produces an enormous disengagement of heat, propagating itself in every direction with an extreme energy; the organic matter is burned in contact with protoxide of nitrogen, a burning gas *par excellence*—the carbonic acid, spontaneously produced and dilated by heat, joins its expansion to that of the other gases from whence results a vivid explosion.

The cellulose transformed into pyroxyline acquires the

property of dissolving in a mixture of ether and alcohol; it appears, nevertheless, that it is not a true solution so produced, but simply a separation of the ligneous particles, and, according to M. Davanne, a swelling of the fibres analogous to the swelling of the granules of starch, or of fish isinglass in water.

For, upon precipitating a solution of pyroxyline in ether and alcohol by water, we easily recognize the distinct remains of the organic tissue in the deposit formed, composed of elongated fibres which have preserved the principal properties of the nitrated cotton; that is to say, they can be redissolved, partially it is true, in the ethereal mixture, and be instantly decomposed, after drying, upon contact with a burning substance only: the material then fuses, on account of its compactness, the same as gunpowder when pulverized and compressed.

This apparent solubility of pyroxyline in alcoholic ether, is therefore simply only the effect of a disaggregation of the fibres of the ligneous substance, but not of the compound cells of the organic body.

The cells not being destroyed by the dissolving vehicle, and so remaining quite entire in the liquid, it is natural that they should preserve their principal properties in continuing to exercise their condensing action upon the nitrogenous gas, until an influencing cause, such as heat or light, comes to provoke the more or less partial disengagement of the condensed gas, which is then liberated slowly, by reason of the little energy of the cause, and various other circumstances, favourable or unfavourable, amid which the phenomenon takes place. The protoxide of nitrogen, thus disengaged, combines with the elements of the solvent itself, changing it by forming more hyponitric acid, which concurs powerfully to the rapid destruction of all these substances. Whatever be the care employed in the preparation of nitrated cotton, after it is dried it instantly disengages a small portion of the protoxide of azote it contains, of which the oxygen of the atmosphere determines the conversion into hyponitric acid, which is always found in large quantities in bottles in which gun cotton has been kept.

When the vessel containing the gun cotton is hermetically closed, and the disengagement of the gas is very little favoured by any external influence, the hyponitric acid formed, withdraws the water from the ligneous matter and partially decomposes it; nitric acid is also formed ultimately, the action of which upon the pyroxyline and the organic portion of the substance, disengages the oxygenic elements of the nitrogen, and ends by causing a more complete destruction. A portion of the mass becomes liquid under the prolonged action of the nitric acid, and is converted into a substance similar to xyloidine, which the water precipitates from its solution, and there remains in the liquid other matters, soluble and deliquescent, arising from a more advanced decomposition; for these phenomena are slow to be produced, so that several different compounds must be developed in succession.

Nitric acid does not form a true combination with cellulose, hence a product, the elements of which are in definite proportions, cannot result; and it is the diversity of these proportions which gives rise to the variety of pyroxylines, which may always be seen among the specimens arising from different manufactures.

It is generally admitted that there are four varieties of pyroxyline, because analysis has sometimes afforded, according to the species, 2, 3, 4, or 5, equivalents of a nitrogenous gas, which is considered to be hyponitric acid, but which is also oxygenized, finally only by the modifications it undergoes during the reactions effected by the decomposition of the organic matter.

Moreover, these numbers, which are taken to represent the equivalents of the composition of the fulminating matter, are rather only the two extremes, in some respects, that are most frequently found, and between which there may be an infinity of varied proportions. We are sustained in this supposition by the diversity of proportions found by every

author who has attempted its direct analysis, and from which, finally, we have only been able to deduce general averages, the summary of a great number of experiments.

This, however, is easily understood, when we know that these varieties of pyroxyline are constantly mixed in the specimens obtained, no matter what the method of fabrication has been; it is therefore only the dominant species which constitute the properties, more or less characteristic, of the whole. But these species do not really exist, and why we admit them, as we have before stated, is, the varied and in determined proportions according to which is produced the absorption of the gas in the capillary interstices of the fibres of the ligneous matter.—*Bulletin Belge de la Photographie*.

Upon the preceding the editor of *La Lumière*; M. Gaudin, remarks:—"I readily admit, with M. Testelin, that nitrated cotton is not constantly in definite proportion. The action of nitric acid upon the cotton differs constantly with the proportion of water it contains, to such a degree, that in the preparation of a single tuft, we may be certain that the proportion first imbibed differs in nature from the portion last imbibed, in consequence of the accumulation of water in the acid, which has already acted, remaining, for I have proved, by a decisive experiment, that the reaction is instantaneous. It is also certain that the nitrated cotton is unstable by nature; with time it undergoes a kind of fermentation, which sometimes causes it to explode, and it is this which forms an insurmountable obstacle to its employment as a substitute for gunpowder. Witness the catastrophe at Bouchet, where some thousand kilogrammes exploded spontaneously, scattering the building in which it was contained to dust, and even hollowing the earth beneath it, like a funnel. Photographic cotton is less explosive, nevertheless from time to time it causes serious accidents; and quite recently, the explosion of some kilogrammes demolished the laboratory of M. Mathieu Plessis.

"But to conclude that the instability of the product is due to the absence of combination, appears to be an error, when we consider the known properties of photographic cotton, it *dissolves*, in fact, in alcoholic ether. I underline the word, to express that it is a true solution rather than a simple suspension. In fact, photographic collodion constitutes a *perfectly transparent* liquid—a quality which never attaches to a body held in suspension, if held, as supposed. Upon slowly evaporating it on an impervious surface, it detaches itself in limpid glassy pellicles, which also preclude the presence of any detached body. Finally, the filtering of collodion through paper, which succeeds very well, abundantly proves that the cells, if cells there be, cannot exceed the hundredth part of a millimètre in diameter, and this absolutely excludes any idea of ligneous fibre. Soluble photographic cotton, therefore, constitutes a true combination of lignine with certain oxygenised products of nitrogen; but there exists also a series of these products which differ from each other by insensible degrees, from whence results the difficulty of constantly obtaining the same product, when following, as nearly as possible, the same conditions of fabrication."

TO SECURE CLOUDS IN LANDSCAPES.

BY W. U. WARNER.

In the NEWS of this week, I read, under the above heading, a (to me) somewhat complicated arrangement for the securing of the very beautiful effects of cloudland. Having, in the course of my professional engagements, been often compelled to resort to various "dodges" to effect the best results in the securing of such effects, and knowing that simplicity in apparatus is at all times desirable, I will proceed to give you my little contrivance, which was arrived at by a puff of wind having one day blown over my camera.

The lens I was working with, was Dallmeyer's No. 1 triplet, to which was attached his flap shutter, made, as you know in mahogany.

My view consisted of a very white parsonage-house, with a

lawn in front cut up into beds, containing a large quantity of green leaves of various shades; behind the house were some very picturesque clouds, which I was desirous of obtaining. The size of the picture was 10 by 6.

Having focussed, I proceeded, as usual, to prepare the plate, when a sudden squall arose, and the catastrophe occurred as mentioned above, whereby the flap and sides of the shutter were broken. Then the following idea suggested itself, which has since been perfected by Mr. Robert Murray of Murray and Heath, viz., to make one side of the shutter a little broader than the other, and in the place of wood to have metal sides and flap; then to ascertain the exact angle at which the lower line of the shade divides the whiter portion of the picture from the darker, marking this by a lead pencil line on the broad side of the shutter. On exposure, proceed thus:—open the flap at first 1-16th of an inch within that line, holding the brass knob by which the flap is raised in your hand, according to the exposure you wish to give the foreground; at the same time move the shutter upwards and downwards, in a rapid movement, four or five times during the exposure of the foreground, say half an inch above the line marked on the side of the shutter in order to soften the light into the dark, and thus avoid an abrupt line; then for a moment close the shutter; next open the whole for one or two seconds, as the case may be, to give the clouds.

The same principle may be applied to the taking of street views, where you require an absence of people and perfect delineation of buildings. Having lately—in fact, at the beginning of last month—been requested to take a view of the Ross Corn Exchange, for the purpose of engraving, and its situation being in the main street, with people constantly passing and repassing, I found that to get a satisfactory picture it would be necessary, in the foggy frosty weather we then had, to give an exposure of two or three minutes. This, you see by the specimen sent, was done, the only figure being the one placed there in order to give the comparative height of the building. All this has taken much time to explain, the actual operation taking only a few seconds to effect.

THE URANIUM DEVELOPER.

Mr. J. R. Wood, writing to the *American Journal of Photography*, says:—"I saw it stated in the PHOTOGRAPHIC NEWS that Dr. Van Monckhoven was experimenting on developers, and that he had found protosulphate of uranium to develop collodion pictures with less exposure than protosulphate of iron. Wishing to try that salt for that purpose, and having some of the sesquinitrate of uranium by me, I converted it into the protosulphate by the following simple means:

If a solution of sesquinitrate of uranium in water be heated with clean iron filings, decomposition soon takes place, precipitating the protoxide of uranium, which mostly adheres firmly to the excess of iron filings. If these be washed and then mixed with a warm dilute solution of sulphuric acid, the precipitated uranium rapidly dissolves, forming a dark green solution, which requires filtering. This solution, mixed with an excess of sulphuric acid, I have used as a developer, and believe it to require less exposure than the sulphate of iron with acetic acid. Perhaps some of your readers might try it, and report."

TO PUT A PAPER POSITIVE INTO A LOOKING GLASS.—A correspondent sends us the following, which may interest some of our readers. Having cut out the picture, take a quarter plate glass, well cleaned, lay a sheet of tin foil on two or three thicknesses of cloth or paper, and spread some quicksilver with a piece of cotton wool. Next, attach the portrait with varnish, to the glass. All being ready, lay a sheet of clean paper on the top of the quicksilver, and place the glass, with portrait attached, on the sheet of paper. Now press hard, and draw out the sheet of paper gently. The quicksilver will run round the edge of the portrait, making a beautiful looking-glass, with a portrait in the centre, giving an effect, something like a daguerreotype.

SPIRIT PHOTOGRAPHS.

In making some further extracts from these extraordinary narratives, we may suggest the singular resemblance between the images described and the phantoms which sometimes appear as the result of imperfectly cleaned plates, on which pictures have before been produced. It will be noticed that only a portion of the figure is generally visible; that it has a shadowy indefinite appearance; and that it is often accompanied by fog and stains; which, in the narrative, are described as "cloudy vapours," "white undefined masses," "blurs," &c. The image, too, is often of a different size to the sitter, as though it is suggested "the spirit were at a different distance from the camera;" no allusion being made, however, to the trifling difficulty in regard to focus, which must follow. It is probable that the idea has had its origin in the reappearance during development of the imperfectly-removed image of a former picture, and this has been received by some credulous persons as a spiritual manifestation. That which originated in delusion is probably maintained by imposture, by a variety of possible means. The identification of the images as portraits of deceased friends, is only explainable by remembering that such barefaced impostors as Joe Smith, the Mormon Prophet, found thousands of followers, and that the wildest delusions have never been wanting in "respectable evidence" and unhesitating believers.

These are not the fitting pages for entering into any discussion of the claims of spiritualism, as it is termed, but we are somewhat concerned in protesting against our art being made the auxiliary either to delusion or imposture. The *Spiritual Magazine* remarks:—

"Those who are so carefully making their investigations are not ignorant of the manner in which the well-known stereoscopic ghosts are produced, of which the invention, like that of the stereoscope itself, is claimed, and we hope more honestly than the latter, by Sir David Brewster. These ghost imitations are produced by having a figure dressed to represent the unearthly visitor, and standing in position during just half the time required for the full operation, then moving away, giving the objects behind it the other half, to impress their image faintly on the negative plate."

"Dr. Gardner, in his address to the Boston Spiritual Conference, says:—'To me there is no cause for doubt. The pictures themselves furnish evidence in their gauze-like appearance, that has not been imitated. Careful examination will show the counterfeits that have been made to be essentially different. I do not doubt that Mr. Mumler is a peculiar medium, and has an organization and magnetism adapted to the production of these spirit photographs.'

"In the *Banner of Light*, of the 29th November, is also contained an elaborate review and description of the process and its results, from which we make the following extracts:—

"They are ordinary *cartes de visite*, but with a faint additional figure, not defined by a distinct sharp outline, but vapoury and semi-indefinite. The whole of the figure is not displayed, usually, only the head and bust.

"The first is a portrait of the medium, W. H. Mumler, with one hand on a chair, the other holding the black cloth covering just taken from the camera. In the chair sits a half-defined female form, apparently about twelve or fourteen years old. This was at once recognized as a deceased female relative. A cloudy vapour hovers about the head of this spirit—an effect we never before saw in any sun picture. One we have seen has a faint disc of light about the head, as if luminous rays were shooting outward, but all stop at a determined circular outline. Two others have a similar effect, but the circle would be sufficiently large to enclose the whole figure, if the card were of greater dimensions.

"The second picture taken by this medium has the spirit of a lady sitting on a chair, with a white undefined mass of something behind her, like two or three pillows. The features are quite sunken, with a serious expression. We are told this is a likeness of the spirit sister of Mr. J. J. Ewer, as she looked when wasted by consumption. The father of the deceased fully recognizes the likeness, as do the rest of the family.

"The next is an elderly lady leaning on a chair, in which

sits a faintly-defined form of a young man playing upon a guitar. This figure is shown more fully than the last, one leg being visible to below the knee, the other not being visible at all—looks as if moved, leaving only a blur. This was at once recognized as a deceased brother, who made guitars and was fond of playing upon them.

"Another is a female figure leaning upon a chair, the hands placed together, and eyes elevated as in prayer. The spirit appears of a larger size, the face and bust only visible. The face is elevated, as if in prayer.

"Another is a gentleman sitting, with the edge of a white marble table near him. The spirit is behind him, and a little smaller—a female figure, with the hair dressed quite plain and Quakerish, a small white collar about the neck, tied with a dark ribbon, a close fitting dress, visible only to the waist.

"A gentleman from Illinois sat for his portrait, and raised the right hand as if holding something. He was told that was a very unbecoming attitude, but he said, "No matter; take it so." When the plate was developed, there sat upon the raised arm a child, leaning its head upon the sitter's shoulder. This child is not very clearly defined; it appears a little larger than in nature, as if nearer the camera than the arm it sits upon. The dress is transparent, with the hand and arm of the sitter seen through it.

"Here is another, an elderly lady, in a dark dress, standing by a chair. The spirit of her deceased husband is with her, a man evidently older; the figure about the size of the lady. A standing collar is visible on one side, the other turned down; black neck-stock, white shirt bosom. The other portion of the costume is not distinctly defined. This is Isaac Rabbitt, inventor of the celebrated Rabbitt metal. The lady referred to above is Mrs. Rabbitt, the wife of the deceased, who assures us that the picture represents her husband as he appeared in his last illness, and she pronounces it, unequivocally, a good likeness, and *knows* that she has not been deceived by the artist.

"The next is a portrait of Mr. Luther Parks, an elderly gentleman, well known in this city, sitting with his hat on. The spirit in this picture is entirely unlike any of the others. It is a female figure floating in the air, the hair combed back over the head, a loose-fitting dress with short loose sleeves gathered in at the elbow; a bracelet on the left fore arm, which is extended, with a wreath of flowers in the hand, toward the gentleman. The right hand is pressed against the side, and over the head (not on it) floats a wreath of flowers. This spirit is quite transparent, the folds of a curtain being distinctly seen through the whole of it.

"Dr. William B. White has two photographs taken at the same time; one (a lady) in front, and another behind a chair. These spirits, he says, have been with him many years. He is a clairvoyant, and sees the spirits and talks with them. They told him, eight years ago, that the time would come when a group, sitting at a table, would have their photographs and those of their spirit-friends taken together. Still further; that they would be taken in colours.

"The last we shall notice, at this time, is that of a gentleman of commanding figure, noble bearing, and dignified demeanour, well known, particularly to express agents in the business community, who stands by a chair, in which sits the form of a young man reading a book. Another picture of the same gentleman has the dim form of Daniel Webster near him. The statesman is recognized at a glance, and bears a close resemblance to portraits painted in the latter portion of his lifetime—the sunken cheeks particularly. The top of the head is bald, with the hair combed up from each side. The expression of the features is very grave and solemn. The dress is not distinct, but, so far as it can be perceived, is unlike anything in the painted or engraved portraits, but slightly resembles the costume on the Washington statue, in the State House; nearly half the figure is displayed, and is a little larger than the mortal, as if nearer the instrument. It is quite transparent, the chair being quite distinct behind it.

"The spirit of Webster purports to be frequently with this gentleman, manifesting its presence whenever a suitable medium is available. This gentleman has received from Webster a private signal, by which he says he is able to identify its presence, and, therefore, that he is not liable to be imposed upon by any other spirit. While in position for this picture, he experienced the usual signal, thus adding another proof of identity."

"Dr. A. B. Child, of Boston, says—

"Mr. Mumler invited me to bring my own glass on which

to make the picture; to examine the camera, its tubes, and lenses; his chemicals; to see him apply the collodion to the glass, and immerse it in the silver bath; to see him take it out of the bath and put it in the shield, then in the camera, and then to go with him into the dark closet, lighted only by a little lamp, and see him take the glass from the shield, which is a little dark box, then pour on an iron preparation, wash it under a stream of water, and then hold it to the little lamp, and see the picture of a mortal and a spirit on it. In compliance with this invitation, I carefully observed all the above operations in detail.

"Mr. Mumler asks for any fair investigation that shall convince the people that his claims are just and genuine. This is right, and as it should be. And it is not unjust or ungenerous, in a new thing—so great and so beautiful as this, if true, must be for the people—to ask the privilege to *prove* it true beyond the shadow of a doubt."

"And in a letter written a week after, and after further investigation, Dr. Child says:—'The best and oldest photographic artists in Boston are unanimous in declaring that they know of no means by which these pictures can be produced, as Mr. Mumler produces them.'

"Mr. Joseph B. Hall, of Portland, Maine, writes to the *Banner of Light* an account of his experience, which appears to contain a good test. He says:—'I was permitted to go into the "dark room" with the operator, and I saw another figure, beside my own, developed upon the plate. Being unable to wait for the picture, I came home, and, a few days after, copies were sent to me. At first, although the face of the spirit-figure was familiar, I did not recognize it, as I confess I was looking for some one of my relatives; but soon I recognized the countenance of a young friend of mine, who died in Augusta, Me., some three or four years since. He was not in my mind when I sat for the picture, and I had hardly thought of him for months. Immediately I forwarded one of the pictures to the friends of the young man at Augusta, *without* intimating to them that I had recognized it. Yesterday I received a letter from his sister, from which I make the following extract:—

"I received the photograph, and it was my brother F.—. The likeness nearly overcame me, it was so plain. His collar and cravat are precisely as he used to wear them. It is as plain a picture to me as the one hanging in my room. We all see it alike, and I think any one who knew him must see the likeness at once. It was a great surprise to me, for I never dreamed of seeing any of our friends on your picture; I hope, however, that the test will make up for the disappointment to you. I do not think these pictures *flatter*, but this is a true likeness.

"Augusta, Me., November 16, 1862."

"The point has been raised by one of the New York papers, and Judge Edmonds has written the following letter, which puts the question on its true basis:—

"To the Editors of the *Evening Post*.

"Your article of yesterday in regard to spiritual photography professes to solve the mystery, and announces that Appleton's artist can do the same thing, wherever there is a photograph of the dead person.

"That is not the mystery of this thing. But it is to take a picture containing a likeness of a person who is dead, and of whom there is no photograph or likeness in existence!

"This is what the Boston operator professes to do, and the question is, "Is that so?" J. W. EDMONDS."

We echo the question of Judge Edmonds—"Is that so?"

The International Exhibition.

REPORT OF THE JURY ON PHOTOGRAPHY AND PHOTOGRAPHIC APPARATUS.*

PROGRESS SINCE 1851.—THE PRINTING COMMITTEE.

To the discovery of the collodion process, no doubt, may be attributed the immense impetus which was now given to the art. Daguerreotypes had been taken by Beard as early as the year 1843, he having patented for England that process which the generosity of the French Government had thrown open to the world by awarding a pension of 10,000 francs for the discovery—4,000 to Daguerre, and 4,000 to Niecepe. Claudet and Mayall, with some half dozen others, comprised all the professional photographers in 1852, who supplied the photographic wants of the public. After another five years there were in the metropolis alone above 150 establishments for the taking of photographic portraits; and, again, at the present time, the "London Directory" tells us that there has been a vast increase.

* Continued from p. 3.

This must still comprise but a very small portion of those who obtain their living by the sun's rays. Scarcely a favourable spot for the practice of the art is left untenanted; and we were lately informed that, for a desirable house in Regent Street, an enterprising and wealthy firm had given nearly double the former rent obtained for the premises. Every country town of note, and even some remote villages, now possess one or more practical photographers. Travelling photographic vans also throng the rural districts; and a statement of the consumption of photographic requisites seems to be quite fabulous.

A paragraph lately appeared in the daily papers stating that one firm alone, in London, used upwards of half a million of eggs annually, to obtain albumen for the formation of positive printing paper.

Beyond the discovery of Mr. Archer, two other causes, especially, have conduced to the spread of the photographic art in England—the formation of the photographic societies of London and Edinburgh, together with other local societies, and the removal of the patent restrictions which threatened the earlier practisers.

In April, 1852, Mr. Roger Fenton issued, as honorary secretary, a proposal to establish a photographic society, in which it is stated that, since the Exhibition of 1851 the science of photography had advanced at a more rapid rate than in preceding years. At the Exhibition of 1851, the lovers and students of the art in all parts of England were brought into more immediate and frequent communication. Ideas of theory, and methods of practice, were interchanged; the pleasure and the instruction were mutual. In order that this temporary state might become permanent, it was proposed to unite in a common society, with fixed places of meeting and a regular organization, "all those gentlemen whose tastes have led them to a cultivation of this branch of natural science;" but, still, a degree of doubt seemed to exist as to the strength of the infant art, for it is suggested that it is needful to ascertain the amount of support such a proposal is likely to obtain, by those desirous of uniting to send their names, with suggestions for its success, to the gentleman who had so kindly undertaken to suggest it and act as the first secretary.

The proposed formation of the Photographic Society, no doubt, influenced the second result, for Sir Charles Eastlake, the President of the Royal Academy, had been in constant communication with photographers, in their previous councils, accepting the office of first president of the proposed society, he, in conjunction, with Lord Rosse, addressed a letter to Mr. Fox Talbot, which, together with Mr. Fox Talbot's reply, appeared in the *Times* newspaper of August 13th, 1852, and, as they are both important in the progress of the history of the art, it is desirable that they should be here recorded.

I.

London, July, 1852.

DEAR SIR,—In addressing to you this letter, we believe that we speak the sentiments of many persons eminent for their love of science and art.

"The art of photography upon paper, of which you are the inventor, has arrived at such a degree of perfection that it must soon become of national importance; and we are anxious that, as the art itself originated in England, it should also receive its further perfection and development in this country. At present, however, although England continues to take the lead in some branches of the art, yet, in others, the French are unquestionably making more rapid progress than we are. It is very desirable that we should not be left behind by the nations of the Continent in the improvements and development of a purely British invention; and, as you are the possessor of a patent right which will continue for some years, and which may, perhaps, be renewed, we beg to call your attention to the subject, and to inquire, whether it may not be possible for you to obviate most of the difficulties which now appear to hinder the progress of the art in England.

"Many of the finest applications of the invention will probably require the co-operation of men of science and skilful artists. But it is evident the more freely they can use the resources of the art, the more it is that their efforts will be attended with eminent success.

"As we feel no doubt that some judicious alterations would give great satisfaction, and be the means of rapidly improving this beautiful art, we beg to make this friendly communication to you in the full confidence that you will receive it in the same spirit—the improvement of art and science being our common object.

ROSSE.

C. L. EASTLAKE.

"To H. FOX TALBOT, Esq., F.R.S."

II.

Lacock Abbey, July 30, 1852.

"MY DEAR LORD ROSSE,—I have had the honour of receiving a letter from yourself and Sir Charles Eastlake respecting my photographic invention, to which I have now the pleasure of replying.

"Ever since the Great Exhibition I have felt that a new era has commenced for photography, as it has for so many other useful arts and inventions. Thousands of persons have now become acquainted with the art, and from having seen such beautiful specimens of it produced both in England and in France, have naturally felt a wish to practise it themselves. A variety of new applications of it have been imagined, and doubtless many more remain to be discovered. I am unable to pursue all these numerous branches of the invention in a manner that can even attempt to do justice to them; and moreover, I believe it to be no longer necessary, for the art has now taken a firm root both in England and France, and may be safely left to take its natural development. I am as desirous as any one of the lovers of science and art whose wishes you have kindly undertaken to represent, that our country should continue to take the lead in this newly discovered branch of the fine arts; and after much consideration, I think that the best thing that I can do, and most likely to stimulate to further improvements in photography will be to invite the emulation and competition of our artists and amateurs by relaxing the patent right which I possess in this invention. I therefore beg to reply to your kind letter by offering the Patent, with the exception of the single point hereinafter mentioned, as a free present to the public, together with any other improvements in the same art, one of which has been very recently granted to me, and has still thirteen years unexpired.

"The exception to which I refer, and which I am desirous of still keeping in the hands of my own licensees, is the application of the invention to taking photographic portraits for sale to the public.

"This is a branch of the art which must necessarily be in comparatively few hands, because it requires a house to be built or altered on purpose, having an apartment lighted by a skylight, otherwise the portraits cannot be taken indoors, generally speaking, without great difficulty.

"With this exception then I present my invention to the country, and trust that it may realize our hopes of its future utility.—Believe me to remain, my dear Lord Rosse, your obliged and faithful servant,

"H. F. TALBOT.

To the EARL OF ROSSE, *Connaught Place, London.*"

On the 22nd December, 1852, the first public exhibition of photographs was opened by the Society of Arts, in their rooms in the Adelphi, and a large number of pictures, principally by the paper processes, were displayed. On the 20th January, 1853, a meeting of photographers took place in the rooms of the Society of Arts, and the Photographic Society was established. Sir C. L. Eastlake, President of the Royal Academy, became the first president of the new society. This society has become the parent of a numerous progeny of other societies, which have since sprung up largely in all parts of the kingdom.

The concessions made by Mr. Fox Talbot, in the foregoing letter, did not satisfy photographers, who felt that the "single point" reserved was that which hindered the practice more than all the others conceded. Accordingly, the art was daily becoming more practised and lucrative to the promoters, when Mr. Fox Talbot, in December, 1854, brought an action against Mr. La Roche, a photographic artist, to restrain him from taking collodion portraits. After a trial lasting two days, before Lord Chief Justice Jervis, a verdict was returned adverse to Mr. Talbot's claim, since which the art, freed from patent restrictions, has progressed with an uninterrupted flow of success.

The early experimentalists in the collodion process confined their efforts mainly to the production of positives on glass, and little thought was originally given to the securing of negatives by that process. On the discovery, however, that the collodion image was suited for use as a negative from which positives on paper might be printed, and that results much superior in delicacy and perfectness of definition, with greater rapidity of exposure were thus obtained, the attention of photographers was chiefly directed to this process. The delicacy of detail which was possessed by the collodion and albumen negatives was found to demand a finer surface for its perfect rendering than that usually possessed by even the finest photographic papers; to meet this difficulty it was proposed to apply to the paper a coating of albumen. One of the earliest records that we find of this application is in a communication by Mr. H. Pollock, addressed to the *Journal of the Photographic Society*, in July 1853. The process has since become general, and is almost universally practised; although the glaze thus given to the surface is not entirely satisfactory in an artistic sense, yet the facility it affords for rendering delicate definition in a class of pictures, the perfect and minute detail of which is an especial beauty, will always be a strong inducement to continue its use.

It is unnecessary here to refer at length to the calotype and waxed-paper processes and their progress since the Exhibition of 1851; they have been, for a variety of reasons, to a large extent superseded by the collodion process. The waxed-paper process has received a variety of modifications, and is still practised with success by some photographers, especially in tropical climates. An allusion cannot, however, be made to these methods without expressing some regret that the calotype process, the oldest method of producing photographic pictures, and one by which many of the most beautiful productions of the art have been obtained, possessing many advantages peculiarly its own, should have fallen so largely into disuse.

A new difficulty soon developed itself, and the want of permanency in photographic prints was forced upon the attention of all interested in the progress of the art.

One of the first to call attention to this falling, and to the importance of devising some means to give greater stability, was the Patron of the Photographic Society, His Royal Highness the late Prince Consort; at his suggestion a committee was formed for the examination of the causes upon which the fading of positive prints depend, and if possible to suggest methods for the securing of permanency.

In May 1855, a committee, consisting of Mr. Delamotte, Mr. Hardwich, Dr. Percy, Mr. Henry Pollock, Mr. Shadbolt, and Dr. Diamond, was appointed by the Photographic Society for this purpose; His Royal Highness the Prince Consort contributing the sum of £50 towards the expenses of the inquiry. The special objects of the committee were thus stated:—

1st. To report upon the evidence that can be collected with regard to photographs that have been printed for a long time; to ascertain whether there are any that appear to be quite unaltered by time, and, wherever it is practicable, to find out the methods by which they were prepared.

2nd. To conduct a series of experiments carefully, preparing photographs by different means, and exposing them under various circumstances, in order to ascertain what method combines in the highest degree the essential qualities of permanency and beauty.

(To be continued.)

Proceedings of Societies.

LONDON PHOTOGRAPHIC SOCIETY.

THE usual monthly meeting was held in the theatre at King's College, Mr. FRANCIS BEDFORD in the chair.

The minutes of a previous meeting were read and confirmed. The SECRETARY then read a letter just received from Lieut.-General Knollys, in reply to a communication from the secretary, in which he stated that His Royal Highness the Prince of Wales would have pleasure in becoming the patron of the society.

The CHAIRMAN called attention to a couple of prints from an enlarged negative, by Mr. W. H. Warner. One was on albumenized paper, the other on resinized paper; the latter possessing more softness and detail than the other, but being a little cold in tone. He also called attention to a series of photolithographs, by Messrs. Simonau and Toovey, of Brussels, produced by M. Asser's process, sent by Mr. G. Wharton Simpson. A couple of rolling presses, by Mr. Wadly, of Sheffield, were also exhib-

ited, and the Chairman explained that Mr. Waddy was present, and would answer any questions regarding them.

The following gentlemen were elected members of the society: Messrs. W. Stouchose, E. Fox, P. Meagher, W. E. Debenham, J. Rivington, and Sir A. H. K. Macdonald.

Mr. S. HIGHLEY then proceeded to read a paper "On Photography in its Relation to the Magic Lantern, Educationally Considered." A variety of mechanical adaptations were shown during the course of the evening, and at the close of the paper an interesting series of transparencies, photographed from nature, and from engravings, were exhibited by means of the magic lantern and the oxyhydrogen light. Amongst these were a variety of fine microscopic objects, a series of transparencies from Kaulbach's illustrations to "Reynard the Fox;" some from Shaw's Bible illustrations; others from Hogarth's engravings; some of Mr. England's Parisian street scenes, and American scenery, and a variety of miscellaneous subjects.

At the termination of the illustrations, the Chairman stated that it was necessary that two auditors should be elected to examine the accounts, against the annual meeting to be held next month. M. Heisch and M. Chaudet, jun., were proposed and elected, and after a vote of thanks to Mr. Highley the proceedings terminated.

Correspondence.

[FROM OUR SPECIAL CORRESPONDENT.]

Paris, 7th January, 1863.

M. E. BAROUX, a wood engraver, has claimed the merit of having solved the problem of photography on wood, inasmuch as by a simple process he obtains the design on wood, *not reversed*, with every delicacy of light, shade, and detail. The wood is not attacked by the sensitive preparations, and if the proof happens to be unsatisfactory, it can be immediately removed by passing a wet sponge over it. The block can then be recovered with the sensitive coating, and a fresh proof taken. The blocks retain their usual hardness and solidity, and are cut with as much facility as blocks unprepared. The sensitive coating is so thin that it offers no impediment to the graver, while it readily receives corrections, or retouching, with the ordinary black lead pencil. M. Baroux has not yet communicated his process, but I name it in order to stimulate your readers to a satisfactory solution of this important problem.

An apparatus for operating with in the open air has lately been introduced by M. Rousseau de la Farge: it permits of working with wet collodion, of sensitizing the plate, and of completely finishing the proof, in full sunshine.

This portable apparatus does not require the ordinary objective to be changed; it serves rather as an auxiliary to it, as they can be united together.

It is composed of a grooved box to carry the glass plates, behind which is a compartment for the bottles. To this box there are adapted two vertical baths, by suitable hooks and fastenings. The upper portion of the baths has a groove equal in size to the thickness of the principal slide, of which more hereafter, and intended to receive it during the operation. To keep it fixed, they are furnished with two stop-plates projecting a little over the opening. The rabbet of each bath is closed on one side, and can be on the other by an india-rubber spring. The opening of each bath is closed by a cover coated with gum-elastic. Pressure is exercised and maintained by two screws.

The nitrate of silver bath must be made of an impermeable substance, which has no action upon the solution, such as glass or gutta-percha; and it must be enclosed in a wooden case. The developing bath, of orange-yellow glass, must be protected in a similar manner. If it be composed of any other impermeable material, it must have two plates of yellow glass fixed parallel to its two sides, and carefully cemented to avoid leakage. The slide holding the plates during exposure in the camera opens at its lower part, and is closed at will by means of a slip of whalebone, wood, or

india-rubber sticking in a groove, and in another external one, having its corresponding sides parallel, and at the same height on the other side.

In this slide there is a second, which plays within the first, and is intended to receive the collodion plate; it is called the *plunger*, because it serves to introduce the plate into the baths by plunging into it. It is formed of bands of copper or of brass, of the same breadth and thickness, soldered together. This slide must be properly silvered. It is moved from the principal slide into the baths, and from the baths into the principal slide, by a cat-gut string passing to the outside by a hole through the upper part of the principal slide.

This plunger may be made of vulcanized india-rubber. A spring, of a particular form adapted to the outside shutter of the slide, permits of a suitable pressure being exercised at will upon the plate placed within the slide.

The manipulations with this apparatus are extremely easy to perform. We commence by placing the principal slide containing the plunger upon the nitrate of silver bath; the slide passes to the opening of the bath, and is stopped by the partition of the bottom at the point of complete coincidence of its opening with that of the bath. We next open the shutter of the slide, and collodion the plate, which is placed in the plunger. Then the shutter is closed, taking care that its spring be properly adjusted; then the stop-plate is withdrawn, and the plate falls into the bath. After it has become sufficiently sensitized, it is returned to the principal slide by pulling up the cord on the outside. The opening of the principal slide is now closed by returning the stop-plate to its original position, the bolt of the springs withdrawn, and then the plate is ready for exposure in the camera. To develop the image obtained, the slide is carried to the bath of protosulphate of iron, and operated with as described. For the sensitizing bath, with this difference, however, that the bath is turned on its hinges so as to examine the development of the image by transparency; the principal slide may then be withdrawn from over the bath on leaving the plunger, which is withdrawn afterwards, so as to avoid staining the principal slide. It now only remains to wash and fix the picture. If necessary, other baths may be established between those mentioned above and the box carrying the glass plates.

Before commencing another picture, the slide must be cleansed of all traces of the iron developing solution. For the movements of the plunger to be perfectly free, the internal space of the principal slide must be narrower than the bath, and the lower opening of the principal slide must be rounded at the edges, and bevelled.

The plunger can be dispensed with by employing silver pincers and a screw, to seize the plate at its upper end. We can also employ different hooks. In this new system the plate moves in grooves formed by the shutters of the slide, and two fillets fixed upon the interior surface of the shutter.

The baths require no sort of modification.

This arrangement can be applied to all kinds and sizes of cameras.

M. leard has communicated the following note upon Graduated Backgrounds:—

“Many contrivances for the attainment of this object have been described, none of which appear to me to be comparable, either in simplicity or in the results obtained, to that which I make use of. The following is a description of it:—I have made a little groove on each side of my pressure-frame, so as to admit of my introducing a piece of wood which completely masks the plate. An oval, of greater or lesser axis, according to the size of the object to be copied, is cut in the centre of this piece of wood. At the moment of exposing the frame to the sun's rays, or to diffused light, the whole secret consists in applying a piece of ground glass to the oval: the light reaching the picture only through this ground glass will give a gradation of tone of exquisite delicacy. In the absence of a piece of ground

glass a sheet of tracing paper will produce the same effect; the piece of wood can also be replaced by a piece of blackened cardboard with raised edges, fitting the frame exactly like a coverlid.”

M. Van Monekhoven has addressed to the secretary of the French Photographic Society the following communication upon the action of light upon certain compounds of silver:—

“In an article contributed by M. Roussin to the Society's *Bulletin*, which I have just received, I read that ‘Iodide of silver is not necessary in the albumen process in order to obtain images in the camera obscura. This salt only increases the rapidity a little.’

“I beg, sir, to refer you to No. 173 of the *British Journal* of the 1st September last, where you will find this fact stated in nearly the following words:—

“1st. In Young's experiment (consisting in the development of an image upon albumen after fixing) the image is not due to the iodide of silver, but rather to the albuminate of this metal.

“2nd. Every process in which, besides iodide of silver, there is present an organic body capable of combining with the nitrate of silver, will admit of development after fixing.

“3rd. In these processes the iodide of silver may be omitted in practice.

“The fact announced by M. Roussin is, therefore, a particular instance of the rule laid down.

“If, sir, any doubt lingers in your mind on this matter, I beg of you to peruse pages 322, 323 of the fourth edition of my *Traité de Photographie*, which I enclose.

“In my opinion, the theory of the formation of the image in the camera may be stated in these terms:—

“1st. In the processes where the iodide of silver is pure, or mixed with an excess of nitrate of silver, the action of light is purely physical.

“2nd. But in the processes where an argentic-organic combination exists in presence of iodide of silver, the action is double; first there is a physical action upon the iodide, then a chemical action upon the organic combination. Besides, the iodide of silver is not absolutely necessary in these processes in order to obtain images in the camera obscura. With regard to M. Roussin's second assertion, I have a few words to say—‘On the rapidity which iodide of silver communicates to the albumenized glass.’ I have, in fact, remarked the same thing, but the profoundest research has proved to me that this is due to the transparency of the albuminate of silver—a transparency so complete, that the light can impress several plates placed one over the other at the same time. But if the albuminate of silver be *opaque* (if the film be very thick), then the luminous rays are *stopped*; besides, I have not been able to discover in these conditions any difference between the sensitiveness of plates simply albumenized, and those albumenized and iodized.”

M. Davanne states, that on two several occasions he has proved that the abundant smoke of tobacco had an influence upon the development of negatives. In one of these instances a colleague attempted an instantaneous process in the presence of several smoking photographers: every negative was *fogged*. Next day he repeated the same process, after the room had been thoroughly aired and ventilated, and the images came out perfect. More recently, himself and a friend developed negatives taken by Taupenot's process, in the same room, with the same materials, and under identical conditions; with the one who smoked the developing solution soon became covered with reductions to such an extent that it had to be thrown away; while the other experiment, taken when the room was free from smoke, was perfectly successful. Numerous facts serve to prove the truth of these observations; and photographers who are in the habit of smoking in their operating rooms, may rest assured that this is the cause of numerous otherwise inexplicable failures.

INDIA-RUBBER PAPER. RESINIZED PAPER.

DEAR SIR,—At the beginning of last year, I tried printing on paper, prepared with india-rubber and gutta-percha, but was then unsuccessful, on account, as I since find, of my using too large a proportion of these bodies.

I have since tried some more experiments with the same substances, and some of them have turned out perfectly successful. I was much surprised to see that so many have been trying india-rubber, as I thought the idea of using it to render the paper waterproof before printing, had not been made public. As in the last number of the PHOTOGRAPHIC NEWS you say that you would be glad to receive practical details on the subject, I thought that your readers would like to know the proportions that I have found to answer best. Procure some pure benzole, and in four ounces of it, dissolve twelve grains more or less, of pure india-rubber. I say more or less, as different samples of india-rubber are very variable, as regards the extent to which they are soluble in benzole. Some of them swell up to an enormous size, and refuse to dissolve at all. After a suitable sample has been procured, and the correct quantity determined, it is best to keep to it. The india-rubber may be dissolved with advantage, in a little chloroform, before adding the benzole. When dissolved, allow the solution to stand till perfectly clear, then pour off the top portion with a flat dish. To prepare the paper, immerse in the way I directed for resinizing paper, draw it from the solution, and hang it up by two corners to dry. Great care is requisite to prevent streaks. Dust must be excluded, as far as possible, from the room, as any of it adhering to the paper whilst wet, would cause a kind of comet. When the paper is dry, it will present a beautifully even, and slightly glossy surface. The paper may now be floated on either of the following solutions:—

- No. 1.—Distilled water 1 ounce
Chloride of Ammonium ... 6 or 8 grains
- No. 2.—Chloride of Ammonium ... 6 or 8 grains
Iceland Moss..... 6 grains
Distilled water 1 ounce

The moss should be washed in cold water before pouring the boiling water upon it.

Or, No. 3.—The waterproof paper may be resinized.

The bath I used is 70 grains to the ounce, with $\frac{1}{4}$ drop of nitric acid.

By either of these three formulæ, charming prints may be produced.

The toning and fixing, is performed as usual.

A curious fact with regard to resinized paper, has recently come under my notice. I was much astonished to see a batch of prints remain, after fixing, as dark as when they were taken from the printing frames. I was at the time, at the printing establishment of one of our first photographers, and, as several prints printed there, did not lose at all, I was rather vexed that I could assign no reason for it, and to test whether it was to the chemicals used in toning and fixing that it was due, I brought a few prints away with me, and toned and fixed them at home, where they all lost considerably. I have since discovered the reason of this apparent anomaly, and now save a great deal of time, by not printing much deeper than the finished print is required to be. Upon removal from the printing frame I wash in two changes of distilled, and one of common water, and use a toning bath of acetate of soda and gold, in the proportion of 20 to 1, made at least a week beforehand, and never use either the toning or fixing bath more than once. From this, it will be seen, that if the print is washed at first in water, containing a chloride, and toned in a comparatively new bath, it will lose to a very serious amount.

Should you think this letter worth inserting, I should be glad if you would do so,—I am, dear sir, yours truly,

H. COOPER, Junr.

5, Aberdeen Park, Jan. 3rd, 1863.

Photographic Notes and Queries.

AMMONIA NITRATE BATH.

SIR,—Upon looking over the notices to correspondents, in the NEWS of the 2nd instant, one C. P. W. complains of blisters upon albumenized paper, floated upon the nitrate of ammonia bath. I beg to offer the remedy—namely, add a small quantity of alcohol; I use about four ounces in a 60 or 70 ounce bath, which at once causes the silver (as it were) to amalgamate as required, upon and with the hitherto repellent-surface.—I am, sir, yours obediently,

J. J. HOBBS.

WASHING PRINTS.

SIR,—Possibly the following idea has been already considered, but I have not seen it noticed. To every photographer, the washing of the prints is a dull, manual operation, without a gleam of science to enliven it. To supersede this troublesome process, I think that the air-pump might be applied, as follows: Place the prints in the receiver of the air-pump, and exhaust the air; this being done, admit water, which will of course immediately saturate the paper, then empty out the water, and again exhaust the air. Repeat this process, in proportion to the amount of the prints to be washed. The chemicals that dissolve in water will, I think, by this quick process, be carried completely away; whether the print will be damaged, can only be seen on trial. The experiment would require a very slight modification of an air-pump, and I would have tried it, but do not possess such an instrument, nor am I aware of the existence of one within sixteen miles of my residence. As I do not think that there is a photographer within the same distance, I have no one but you to consult, and trust you will pardon a "tyro" and "amateur" in so doing.—Yours truly, G. W. O.

PHOTOGRAPHY ON CANVAS.

SIR,—In the *British Journal*, Dec. 15, occurs the following:—

"On the same occasion M. Disderi announced that he had just been negotiating with an American artist, who had found out a means of producing positive pictures on the prepared canvas employed by painters. At M. Delessert's, and also at Disderi's, I have seen several specimens of this novelty, and must acknowledge that the result is most remarkable. The painter having only to terminate the sketch traced for him by photography, and being no longer inconvenienced by the nature of the substance he is painting upon, produces a work which has all the merit of photographic accuracy, and which at the same time has given him free scope for his talent."

I have no desire to detract from the merit or originality of the invention; but I shall feel obliged by your allowing me the privilege of stating, that as long ago as February, 1859, I had made experiments with a view of obtaining the same desideratum; and in March of the same year I had succeeded in producing perfect prints upon canvas as ordinarily prepared for the painter in oils, and had shown them to several photographers.

I hope to have several specimens of my process at the forthcoming Exhibition of the Photographic Society.—I am, sir, your most obedient servant,

Jno. T. LUCAS, Junr.

3, St. John's Wood Road, Regent's Park, Dec. 16th, 1862.

RESINIZED PAPER.

SIR,—My object in thus intruding myself to your notice, is to say a few words on the now controverted subject—photographic paper.

It is scarcely necessary here to remind your readers of the importance of the printing part of photography, as, thanks to your stirring articles on the subject, photographers have aroused themselves to take better care of this neglected part of the art.

We find most, if not all, photographers using albumenized paper in preference to any other, and yet albumen contains sulphur, the dread enemy of photographic prints; so we find in the very foundation of the proof sufficient cause for premature decay. Now, if any one paper at present in existence may be recommended, it is Mr. H. Cooper's resinized paper, described in one of your papers. This paper has many excellent points, and surely no better recommendation is needed than its well-known preservative qualities. I fear to presume too much on your time, or I would give you a formula for toning used by me, with the best results.—I am, sir, yours truly,

D. K. GRIFFITH.

Talk in the Studio.

CHEAP ALCOHOL.—A method of extracting alcohol from coal gas has been discovered at St. Quentin, France, by a young chemist named Cotelle. He announces that he can sell his alcohol at 25 francs the hectoliter, while the most inferior spirits produced from other articles is selling for 75 francs the hectoliter. One equivalent of alcohol contains 4 equivalents of olifant coal gas and 2 equivalents of water. There is nothing new about the obtaining of alcohol from gas; this has been done before but it cannot be manufactured so cheaply as from grain. Olifant gas can be made of alcohol as follows:—Take 1 ounce of strong alcohol and 4 ounces of concentrated sulphuric acid and place them in a glass retort capable of holding 10 ounces, and apply a gentle heat. When the liquor boils, olifant gas is given off. The sulphuric acid should be added to the alcohol in small quantities, and the retort should be shaken after each addition. The olifant gas thus obtained for experiment is usually passed through a weak solution of potash to wash it.

PORTABLE CAMERA.—We have recently had an opportunity of inspecting a very ingeniously contrived portable stereoscopic camera, invented by Mr. Hooper, and manufactured by Mr. Petschler of Manchester. The front is hinged at the bottom, and so arranged that it can fall back, with the lenses *in situ*, into the body of the camera. A case which holds three double backs, is attached with hinges to the back of the camera, but is so made that it can easily be removed. The whole, when packed up, forms a compact and convenient parcel.

NEGATIVE VARNISH.—We understand from Mr. Solomon, that a spurious imitation of the negative varnish of Soehnle Freres, has recently got into the market. As we have heard we have heard frequent complaints of the deterioration of this varnish recently, it is possible that this may account for the change. It should be an easy matter for photographers to assure themselves that they purchase a genuine article.

PHOTOGRAPHIC EXHIBITION.—Cards of invitation for the private view of the Exhibition of the Photographic Society have just been issued. The day is fixed for Saturday, the 10th, from twelve till dusk. On Monday it will open to the public.

THE ROBBERY OF LENSES AT THE CRYSTAL PALACE.—*George Restall*, late manager to Messrs. Negretti and Zambra, opticians, of No. 1, Hatton-garden, at their photographic establishment in the Crystal Palace, was finally examined, on Tuesday, at the Lambeth Police-court, on a charge of stealing photographic lenses belonging to his employers, of the value of £100. Mr. G. Lewis, jun., of Ely-place, appeared for the prosecution, and Mr. Sleigh for the defence. Sergeant Palmer, the officer engaged in the case, discovered that four of the missing lenses had been pawned at the shop of Mr. Blizzard, a pawnbroker, in the Borough, and that amongst them was one belonging to the prisoner himself. Richard Kinder, the shopman, swore positively the property had been pledged by the prisoner on the morning of Friday, the 31st of October last, and that he subsequently identified him at the Crystal Palace, when he had been taken into custody. Mr. Sleigh called three witnesses to prove an alibi; the first was the female servant of the prisoner, who swore that her master did not go out until after nine o'clock in the morning in question; and two relations deposed they left the house at a quarter past nine, preceded by omnibuses, and accompanied the prisoner to the Crystal Palace; while the pawnbroker's assistant swore positively that the accused pledged the property between the hours of eight and nine. Mr. Elliott, however, committed the prisoner for trial; but on the application of Mr. Sleigh admitted him to bail.

To Correspondents.

* Wanted, for full prices, or in exchange, the following numbers of the PHOTOGRAPHIC NEWS:—76, 80, 81, 91, 101, 197, 198, 200, 202, 203, 213, 214, 215, 216.

J. A. ACKLAND.—The amorphous iodide of ammonium, recommended by Mr. Ackland, is a preparation sold by Messrs. Horne and Thornthwaite, which decomposes much more readily than the usual crystalline samples, and, in Mr. Ackland's experience, gives greater sensitiveness and clearness. We shall be glad to hear further of your success with the iodide-chloride.

A.—The yellow stains are, probably, due to the prints sticking together in the fixing bath of hyposulphite of soda, and so preventing complete and

perfect fixation. A weak, or exhausted fixing bath, might aid in the result. Some trace of hyposulphite of silver is formed, and not dissolved at once by excess of hyposulphite of soda. The result is a yellow stain, which generally occurs in washing. The fact, that it most frequently occurs with vignettes, is confirmatory of this idea, as there is in such a larger surface of white paper containing unreduced chloride of silver, and more, therefore, to be dissolved.

AQUA PURA.—Vulcanized india-rubber would scarcely serve your purpose, as it contains sulphur. We don't see that you can use anything better than a piece of felt.

ROBERT REEKS.—The question entirely depends on the terms of the bargain. If you were employed to produce a photographic picture simply, whether it be a portrait, or a copy of some object, you have, according to the usual practice of the profession, completed your commission when you have delivered the print; the negative belonging to yourself, and, if given up, is generally the subject of a distinct and extra payment. If you were employed to take a negative of the painting in question, then, of course, it would become the property of the person who commissions the work. There is no law that we know of which affects the question, except usage, and that has generally determined hitherto, that, in the absence of an express bargain to the contrary, the negative remains the property of the photographer.

A CONSTANT SUBSCRIBER.—You may either print by development, fixing your negative in an aperture of the shutter of a darkened room, and enlarging on to the paper direct by means of an ordinary portrait lens, or what we should prefer, as simpler and better, take first a transparent positive, and from that a negative enlarged to the desired size. The details are too lengthy for explanation here; but you will find them given on more than one occasion in our last volume, and also in our YEAR BOOK for 1863, just published.

C. M.—We have repeatedly given the formulae and manipulations for toning with gold and acetate of soda. Use 3 grains of chloride of gold, and 90 grains of acetate of soda, in a pint of water. Mix at least twenty-four hours before use. We like the acetate better than the carbonate. See article on the subject in the PHOTOGRAPHIC NEWS ALMANAC, just issued.

S.—A report on your glass in our next.

H. J.—The dark deposit from decomposition in the toning bath is, doubtless, metallic gold. When it occurs, the only plan is to make a fresh bath. Alkalinity, organic matter, light, and a variety of causes, will sometimes bring it about, as well as free nitrate of silver. 2. We do not know of any cement which will unite strips of bladder together *strongly*, and yet remain flexible. Isinglass dissolved in vinegar might be tried, or india-rubber varnish.

HUGH ROBERTS.—If a stereoscopic negative, taken with a bi-lens camera, be copied as a transparency in a similar camera, no cutting or transposition is needed. Each half is, in the transparency, turned round on its own axis, which is practically the same as if the slide were cut in two. It is difficult to explain more definitely here without the use of a diagram, but, by trying the experiment, you will easily convince yourself. In reality the two images are cut, and each turned round in the camera on its own axis, the lens being able to turn round the image without cutting the glass. If you take the stereoscopic print, and after dividing the two halves, turn each round on its axis, so that the top is in the place where the bottom was; you will find you have simply produced the same change in their relative position as if you had transposed them, and this is what camera copying with a pair of lenses effects. Mr. Breese had one stand of Dallmeyer's stereoscopes with achromatic lenses, and another stand with similar stereoscopes by Cutts, Sutton, and Co., of Sheffield, both were first-rate instruments. We do not know any agent in London for those of Cutts, Sutton, and Co.

A. B. C.—Mr. England's use of the No. 1 B, in preference to the "new stereo" in the Exhibition building, was doubtless to enable him to get sufficient definition with a large aperture, having frequently to work in a very bad light. For stereoscopic work this is the chief advantage of the No. 1 B over the stereo lens, sufficient definition over the whole of the picture can be obtained with a much larger aperture, and thus, practically, greater rapidity is gained. Less subject is of course included in the same space with the No. 1 B, as the focus is longer. For interiors, and your purpose generally, we should be disposed to prefer the stereo. It is very rapid. As to the exact ratio of definition, light, &c., we cannot speak with certainty. The manufacturer can probably give you more definite information on that point.

AN AMATEUR.—In cold weather, and with some samples of paper, it will frequently happen that considerably more than ten minutes will be necessary to secure satisfactory tones, especially if the bath be old. Try much longer, or adding a little warm water with a trace of fresh chloride of gold. Vols. 2, 4, and 5 of the PHOTOGRAPHIC NEWS are in print, and may be had at the published price, namely, Vol. 2, containing the numbers of six months, 8s. 6d.; Vol. 4, containing the numbers of eight months, 10s. 6d.; Vol. 5, containing the numbers of twelve months, 15s. It is very doubtful whether we shall be able to make up any volumes at all of last year, as a great many of the numbers are quite out of print, and although we have offered full price for such numbers we cannot procure them.

S. L. G.—It is not necessary to be a member of the Photographic Society in order to exhibit. But we fear you are now too late, as the Exhibition opens on Monday next.

X.—The Ammonia-nitrate bath generally gives greater vigour than the ordinary silver bath. Mr. Hennah, of Brighton, has always used it for plain paper, and his tones have found many admirers. We think them a trifle too black. Tone is much a matter of taste, but a warm tone is generally more brilliant, and does more justice to a good negative than a cold one.

A. L. COKE.—There can be little doubt as to the custom of the profession. The negative belongs to the photographer unless a bargain to the contrary exists. You will find reports on *Mason v. Heath* on pages 115, 204, 234 of the PHOTOGRAPHIC NEWS, Vol. VI, or in Nos. 183, 191, 193. We do not know of any more copious reports. The paper to which you refer do not arrive. We shall be glad to learn the issue.

W. G.—Thank you for the cutting. We shall make use of it when the case terminates.

H. RANSOME.—If you wish to use that formula you should do so as it stands; but you may make an approximation by adding the lime to a solution of chloride of gold. See article in our YEAR BOOK, 2. Some persons prefer the lime and some acetate of soda. It is a question of taste.

THE PHOTOGRAPHIC NEWS.

Vol. VII. No. 228.—January 16, 1863.

THE PHOTOGRAPHIC EXHIBITION.

AN exhibition of the collected examples of any art is always a landmark of progress, looked for with eager anticipation, examined with careful scrutiny, and referred to in after-time as authoritative evidence of the exact state of advancement at a given period. The display of photographs at the International Exhibition of last year, we have always maintained, was not an adequate representation of the art. Apart from the antecedent misunderstanding and the unsatisfactory position, an exhibition representing the progress of eleven years, necessarily contained many things not new to photographers, and possessed much less technical interest than an annual exhibition. The Photographic Society very wisely determined not to exhibit in 1862, nor in any way divide the interest. This year, therefore, we have the examples of two years' progress to compare with the recollections of the last exhibition.

The ninth exhibition of the Society was opened for private view on Saturday, the 10th instant, and was attended by a large and deeply interested assemblage of visitors. The old Water-Colour Gallery in Pall Mall, where the most successful exhibitions, in former years, have been held, could not, unfortunately, be obtained this year, and the present exhibition is held in the rooms of the Society of British Artists, Suffolk Street, Pall Mall. So far as regards space, nothing could be more eligible than the present gallery, consisting of one large room and two smaller ones, and being in the immediate vicinity of the old place, it is convenient on that account. At present it possesses an important drawback, which is a serious detriment to the effect of the photographs. We refer to the want of light: the room is lighted by means of a skylight, on which appears to rest the accumulated dust and dirt of something like a century. This, added to the dark weather which has prevailed lately, renders it impossible to examine the pictures with any approximation to a satisfactory result. When the gas is lighted, the effect is wonderfully improved, but this, we fear, will not often be the case, as we learn with regret that it is not intended to open the exhibition in the evenings this season. The policy of such a course is, of course, decided by a comparison of receipts with costs; but we cannot but remember, that on former occasions the evenings presented the most animated effect, and have secured a full attendance. If it be at all compatible with commercial prudence, we would urge on the authorities the fact, that there are, in London, some thousands of photographers, whose only opportunity of profiting by the exhibition is in the evening. Operators, to whom such exhibitions are of immense educational importance, are closely engaged during the hours of daylight, making the most of the few working hours the season affords; and unless the exhibition be opened in the evening, they must lose all opportunity of seeing it, or, at most, obtain a hasty glance on some single occasion. If it be deemed imprudent, from financial considerations, to open the exhibition every night, we would suggest that it be opened one or two nights in the week, to which due publicity may be given. In any case, let us have light; let the dirty skylight be cleansed. Photographs pre-eminently require a good light for their satisfactory examination, and they lose considerably by the want of it.

The present exhibition is, so far as we can judge at present, a highly satisfactory one. Both in the number and excellence of the contributions it far surpasses those of

former years. The walls of the three rooms are well covered, and something like seventy frames remain unhung, rather from want of space than from want of merit in the pictures. The gentlemen entrusted with the hanging have, on the whole, executed their difficult and delicate task with great fairness and ability. Some modifications doubtless might be desired, but the necessity of making frames fit, as well as the importance of giving prominent positions to meritorious pictures having equally to be considered. Some of the contributions, which it might have been desirable to keep together perhaps, are somewhat scattered about; but this is better than hanging fine pictures in inaccessible positions.

In taking a general glance at the contributions, and reserving for future notices anything like a detailed criticism, we are struck with the amount of uniform excellence exhibited, and the absence of the sooty abominations which have startled us by their hardness in by-gone years. A higher general excellence prevails throughout, and leaves less room for contrast between the works of different men than existed in former years. There are much fewer white skies; there are fewer masses of soot and white-wash; there are few traces of sulphur toning. Some degree of photographic excellence, if not of artistic beauty, characterises almost everything we have noticed.

Prominently fixed on our memory, are the works of three contributors, as surpassing everything we have before seen in photographic exhibitions. These are the "Bringing Home the May," of H. P. Robinson, the "Photographic Studies," of Lady Hawarden, and the large instantaneous pictures of Lieut. Col. Stuart Wortley. The first, as we have before expressed our conviction, is such a picture as never before was produced by photography. It here occupies the place of honour, is the cynosure of all eyes, and excites alternate exclamations of wonder and delight from every visitor. Lady Hawarden's studies are small pictures, but of their class—and it is a charming class—they are perfect gems. As examples of *chiaroscuro*, they are wonderful; and as results, for the most part obtained with the management of light possible in a lady's drawing-room, they are a lesson to all photographers. The exquisite taste, fine feeling, and excellent photography, combine to produce an amount of pictorial effect very rare in photographs. Col. Stuart Wortley's instantaneous pictures of sea, and cloud, and foreground, and atmospheric effect, are sublimely grand. Le Gray has produced magnificent pictures of similar effects, but none like these. Warnod exhibited at the International Exhibition some very perfect large instantaneous views, but they lacked the sense of sublimity which these possess. Breese, Wilson, Blanchard, and Fry, have produced wondrously charming small atmospheric effect, but these are equal in beauty and rarity of effect, whilst they are on a scale rarely attempted in such work.

We have mentioned the three which have struck us most, because of their unusual style of merit; but there are many others of scarcely less excellence, but of a more familiar kind. Here are a splendid series of landscapes by Vernon Heath, from which we are delighted to see white skies entirely banished; a fine display of Francis Bedford's pictures, Eastern and English; Annan's noble landscapes; Henry White's exquisite bits of English scenery; Earl's grand interiors; Thurston Thompson's unrivalled reproductions, and a host of other landscape pictures the mere mention of the artists' names will guarantee their excellence. Here are landscapes by Mudd, Morgan, Dixon Piper, Spode,

Stephen Thompson, Major Gordon, W. W. Rouch, W. Mayland, Sir A. K. Macdonald, the Hon. W. Vernon, G. S. Penny, the Stereoscopic Company, the Amateur Association, and a host of others.

In portraiture, amidst much excellence, the level is more equally preserved. Pre-eminent in his own line, now as ever, are the vignette heads, of T. R. Williams; a large number of very fine pictures by Claudet; a few by Veron Heath; a frame by Mayland; some by McAndrew; and a few others well worthy of notice. The bulk of the portraiture is hung together in one room, a good portion of which is devoted to coloured work, much of which, so far as we can judge from a hasty examination, does not invite further attention, a great deal of it being sad stuff.

One of the most interesting features amongst the examples of portraiture is a series of prints on resinized paper from enlarged negatives, by Mr. A. Harman, Secretary of the South London Society. They are enlarged from card size to whole sheets of paper. The standing figures being about sixteen inches high. The original card is exhibited beside them, and we can unhesitatingly pronounce them to be the best pictures of their kind we have seen. The definition appears excellent, and delicacy and brilliancy are both secured. The enlarged prints appear in all respects fully equal to the small ones by their side, and the resinized paper appears to be admirably suited to the work. We shall examine these again by a good light with considerable interest, and commend them to the attention of all visitors.

There is not a large display of genre pictures. After those of Mr. Robinson, some by Bullock Brothers, also of Leamington, will attract attention, especially one entitled "Footsteps of Angels." This is a very bold attempt, and really striking in result. It is not, however, quite a success, as it fails in conveying its idea, also exhibits some solecisms, or incongruities, in lighting, to which we shall refer on another occasion.

Mr. Cooper has a glass case with some very charming specimens on silk, made into handscreens, watch pockets, &c., and also some fine specimens on resinized paper.

There is an unusually good display of stereoscopic transparencies, by Breese, Ferrier, Fry, Blanchard, and others, to which we shall refer in future. M. Claudet and Mr. England also exhibit stereoscopic pictures.

One room is devoted to foreign contributions, chiefly consisting of specimens from the International Exhibition. To these we shall advert on another occasion.

There are not many specimens of apparatus exhibited at present, two or three manufacturers only having sent contributions.

Owing to the tardiness with which packages arrived, the final steps for opening were taken in a somewhat hurried manner, so that a complete catalogue is not yet issued. We cannot, therefore, arrive at any satisfactory analysis of the processes represented; but so far as we can judge, the wet collodion process is represented in stronger force, compared to other processes, than at any former exhibition.

Scientific Gossip.

PREPARATION OF PURE HYDROBROMIC ACID—SPECIAL PRECAUTIONS TO BE TAKEN.

In our chemical articles we endeavour to place before our readers the most recent and practical information upon the various subjects likely to be of interest to them. Chemical science being, however, one of the most progressive branches of human knowledge, it constantly happens that the novelty of one day is superseded the next. In such cases as these we have adopted the plan of posting up our readers, in the particular subject in which improvement has been effected, by giving a short notice of it under the present heading, in preference to breaking in upon the plan and order of the series of our chemical articles. A case now occurs in which

information given some months back, and the best of its kind then attainable, now requires to be modified and enlarged to bring it down to the present state of science. We allude to the preparation of hydrobromic acid, a compound of considerable photographic value, both on account of its own properties, and also by reason of its forming the starting point to a long series of valuable salts. We will just glance at the different methods employed in the preparation of this acid. One excellent process consists in decomposing a solution of bromide of barium by diluted sulphuric acid. If sufficient care be bestowed upon it there is no great difficulty in getting a perfectly pure acid by this means, as by employing a trifling excess of sulphuric acid, and then distilling, a product is obtained, which is at the same time free from baryta and sulphur. The great objection to this process is, that it is necessary previously to prepare bromide of barium; otherwise it is a very good one. Another plan, is to distil bromide of potassium with dilute sulphuric acid; this involves the same objection as the one just mentioned; and is, moreover, not nearly so convenient, owing to the separation of sulphate of potash from the mixture, if the amount of sulphuric acid be small, and the decomposition of the hydro-bromic acid in the presence of a larger quantity of sulphuric into sulphurous acid and bromine. Balard's process is one of the least satisfactory of any, although it is one frequently used; he recommends passing hydro-sulphuric acid gas through bromine diffused in water. According to theory, the decomposition would consist simply in the hydrogen exchanging sulphur for bromine; but in reality another change goes on at the same time—the first portions of sulphur which separate, unite with some of the bromine, forming bromide of sulphur, and this decomposing in the presence of water, produces sulphurous acid. By far the best, as well as most economical plan, consists in preparing the acid by the reaction of bromine and phosphorus upon each other in the presence of water. These two elements have, however, so intense an affinity for each other that unless some special precautions are taken serious explosions will ensue. It is to these precautions and the modifications introduced into the process by one of our most skilful experimentalists, Mr. Maisch, that we wish to direct attention. A tubulated retort is taken, capable of holding at least double the amount of all the materials. Into the tubulus of this is fitted a funnel tube, and the neck of the retort is placed pointing upwards, and connected with an empty receiver, by means of a glass tube, which is cut off just below the cork; a second glass tube, commencing near the bottom, connects this receiver with another one of the same capacity—any ordinary bottles will answer—and dips into a little distilled water, both receivers being kept cool by ice, or some other means. The phosphorus is first introduced into the retort together with six or eight parts of water, if desired. The bromine must be added only in small portions at a time through the funnel tube, which is immediately afterwards covered with a glass plate. The apparatus is soon filled with white vapours of hydrobromic acid, mixed sometimes with free bromine; the vapours are partly condensed in the neck of the retort, and run back, they partly condense in the first receiver, whilst the last portions are absorbed by the water in the second bottle. This liquid will commence to rise in the tube when the reaction has subsided, and more bromine must now be added. This is continued from time to time until the whole has been used. The proportion of material is one part of phosphorus to twelve and a half parts of bromine. The first receiver generally contains some free bromine, besides some hydrobromic acid. The liquor in the last receiver will mostly be colourless if the condensed liquid from the first one has not been forced over through the connecting tube. If colourless, it is set aside and employed as the absorbing liquid in the next part of the process; if coloured, it is, together with the contents of the first receiver, added to the residue in the retort, and the

whole apparatus is then set aside, if possible, in the direct sunlight. The retort now contains phosphorus, bromine, phosphoric and hydrobromic acid. When it has become colourless after exposure to the light, and occasional agitation, the bromine has been converted into hydrobromic acid. The next step is the distillation of the hydrobromic acid, previous to which, however, every trace of uncombined phosphorus is to be removed. The neck of the retort is inclined, and the glass tube, after the first receiver has been disconnected, is made to dip into a small quantity of distilled water, or into the liquid employed during the first part of the process, if it was colourless, and had not to be subjected to another distillation; heat is applied, and the distillation continued to near dryness. The residue constitutes pure phosphoric acid. In this process, penta-bromide of phosphorus is first formed, which decomposes water when coming in contact with it, forming phosphoric and hydro-bromic acids. Inasmuch as concentrated phosphoric acid is apt to gradually destroy the retorts, it will be well to add after the undissolved phosphorus has been removed, six parts of bromide of potassium, and distil to dryness. As the solution in the retort becomes concentrated, by distilling off the liquid, a double decomposition is effected, resulting in phosphate of potash, and hydrobromic acid, the former of which is very soluble in water, and does not in the least impede the process. When the concussions are observed the fire is to be removed, and the tubulus of the retort opened; the salt becomes solid, and may, by dissolving in water and evaporating in a capsule, be obtained in a dry state. If the phosphorus contained no impurities, it will be pure phosphate of potash, and may be preserved as such for use. It is necessary to warn our readers on one point, which might otherwise produce serious accidents; that is, never to add the phosphorus to the bromine, inasmuch as the affinity of both elements is so great that the phosphorus burns in the vapour of the bromine, causing violent explosions, which may shatter the apparatus to atoms. By proceeding in the manner above described, there is no danger in the operation, the only annoyance being caused by the volatilization of a little bromine while pouring it into the retort.

The season for commencing photographic operations is beginning early, judging from the numerous specimens of glass which are forwarded to us for examination. No less than nine are at present on our table. Out of the whole number, however, there is only one at all fit for the purpose intended. Those marked 1, 2, 3, 4, and 5, are far too light, even 2 and 4 being not half dark enough. Specimens "Gillard 1 and 2" are too brown in colour, and transmit the actinic rays copiously. S 1 is a ruby glass, transmitting only the extreme red; it will certainly answer for photographic purposes, but not any better than orange glass, whilst it will render the room very dark for working in. S 2 has the fault of most of the other specimens, being too light, and of a brown colour instead of orange.

PHOTOGRAPHY: ITS RETROSPECTS AND PROSPECTS.

BY SAMUEL FRY.*

THE opening of a new year seems to offer a peculiarly suitable opportunity to take a slight retrospect of our doings as photographers, and to indulge in a few anticipatory views of the prospect which discloses itself at the commencement of a fresh season. Upon our late season we may look back with mingled feelings of regret and satisfaction—an alloy that, to a greater or less degree tinges all our mundane proceedings—of regret that a wet, cold, ungenial summer, should have to a certain extent marred our efforts, and acted as a hindrance to the prosecution of the desires of the enthusiastic follower of the new-born art; and of satisfaction that, notwithstanding official slights at the International

Exhibition, photography has triumphantly asserted its position, and that on any future occasion of the same nature we may feel sure its just claims will be recognized. Also, we have just cause for gratulation in the unquestionable fact, that the art-progress of photography has been fully commensurate with the expectations formed in advance; if, indeed, it have not in some respects surpassed them.

In instantaneous results—on which I have long insisted depends the future of photography—vast strides have been made; and so many accomplished labourers are now uniting their efforts, that it is only reasonable to expect great things in the ensuing year. Taking, then, all things into consideration, I am clearly of opinion that the prospects of the coming season are of the most hopeful character; and it remains for us individually, during the now short period of winter which must elapse before our active operations are recommenced, to determine fully in our own mind the line we intend to pursue.

I have, on previous occasions, urged the high importance of each taking for himself some particular line to delineate, and to devote all the energies to that, rather than by an incoherent following out of general principles to involve the mind in confusion, and, perhaps, to continue for a length of time pursuing an erratic course, and following a number of irrelevant subjects, without devoting a sufficient period to any single one to obtain proficiency therein. These remarks will apply with especial force to gentlemen whose time for these matters is very limited, and for whom it is of paramount importance to have clear, distinct intentions.

So many subjects, all of surpassing interest—some of them almost sublime in the beauty of their results—open upon the mind that any one, especially a tyro, may well be excused for hurrying for a time, butterfly like, from flower to flower. He tries in turn portraiture, landscape, stereoscopy, instantaneous works, albumen, collodion, dry plates, enlarging, microscopic reduction; there seems no end to the field, no limit to the value, commercial as well as artistic, of the subject.

We have now, thanks to eminent opticians and clever mechanists, exquisite lenses and admirable apparatus; our chemicals are more certain than ever; iron development and separate toning and fixing, have changed the whole aspect of affairs within a year or two, and there is now more scope than ever for the artistic photographer. Clean working can no longer carry off the palm, so large is the number of those who are able to fulfil all that can be desired in this way. No! photography must take higher ground, and assist in an uncontrovertible manner its intimate alliance with the fine arts. The painter, with a proud conception pre-arranged in his mind, looks to nature for his inspirations, and secures in his sketch-book studies called here and there; sunny skies, browsing herds, trees, rocks, and all that nature or art, judiciously selected can furnish to enrich his canvas and enhance his reputation. It is competent—nay, it is incumbent—on the photographer to do this also, if he desire to be of the same class, and to enforce the dogma that our art, when perfected by the united discoveries of science, and labours of the artist, should be entitled to rank as a fine art.

ON THE ACTION OF LIGHT ON BROMIDE OF SILVER.

BY M. AUG. TESTELIN.

IN almost all photographic processes in which iodide of silver forms the principal basis of the sensitive material, a certain quantity of bromide is added, corresponding to the soluble metallic iodides which must subsequently form the salt of silver by double decomposition with the nitrate of the sensitizing bath.

To the bromide of silver—which thus necessarily results in the preparation of papers or plates coated with collodion or albumen—belongs the peculiar property of being im-

* Read before the South London Photographic Society.

pressed under the action of the yellow and green luminous rays, differently and more easily than the iodide is, under similar circumstances.

In order to overcome the difficulties experienced in the representation of subjects in which the tints are very varied, and opposite in their chemical action, it is customary to introduce into the collodion a relative quantity of soluble bromides corresponding to the iodides which form the base of the generating salts, and by this addition we render coloured objects more completely than could be hoped for as perfect by any other means.

This fact is very important in photography, and has induced us to examine into the fundamental principle; whereupon we perceived that an error, apparently confirmed by experiment, had led to the conclusion that the action of coloured light upon bromide of silver, differs from that which this agent exercises upon the iodide of the same metal obtained and preserved under the same conditions. It is generally admitted that the green and yellow rays of the solar spectrum act relatively with greater activity upon bromide of silver than the other coloured rays; but if this fact be substantial and demonstrated in practice, the principle attributed to it is altogether illusory, as we shall attempt to show.

Suppose, for example, that we project the solar spectrum upon a white screen, in order that, by thus arranging a series of very pure and vivid colours, the experiment shall be clear and definite. In the place of this screen, substitute a glass plate covered with collodion prepared with iodide only (without bromides). After ten or fifteen seconds, withdraw the plate, and develop it with a weak solution of sulphate of iron, prepared in the usual manner, and there will appear a black confused trace along the entire length of the spectrum, extending from the red to the violet, and even beyond it. Upon examining the negative, we further discover that the portion impressed by the violet rays is grayer and more transparent than the rest, which indicates too long an exposure.

Experimenting afterwards with fresh plates, we reduce the time of exposure to the coloured spectrum until the most active portion (the blue and violet), has produced its maximum effect, without, however, exceeding it. Let us suppose that this space of time is a second, for example; after examining this last negative, we remark that the image obtained does not extend so far as before, and that the luminous action diminishes from the blue towards the green.

From these experiments we conclude:—

1. That the iodide is susceptible of being changed by all the coloured rays of the solar spectrum.

2. That this action is stronger with the violet, blue, and green rays, and much less active with the yellow, red, and orange rays.

3. That the action which light can exercise upon iodide of silver may be easily excessive, when there is chemical decomposition, and the effect of the developing agents no longer produces a picture, or at least, they act more feebly in causing the image to appear.

This last property, therefore, opposes itself to prolonging the exposure to light in order to obtain an impression from the green, yellow, orange, and red rays. Now, if we operate on a sensitive substance, which does not possess, like iodide of silver, the property of being "over-done" when developed, it is, of course, sufficient to prolong the exposure within determined limits, for this or that coloured ray to have time to produce an action which may be regulated in such a manner as to be relative to its apparent intensity, compared with the hues of the whole object.

It is precisely this property which is possessed by bromide and chloride of silver; these salts will even take a deeper tone under the action of light, without, in consequence, losing the property of being darkened by developing agents.

This characteristic of bromide of silver, then, very clearly

explains why this salt appears more sensitive to the green rays than iodide of silver, as it is equally susceptible to all the other coloured rays. Added to iodide of silver in the sensitive film, it in no respect modifies its properties, nor communicates new ones; on the contrary, where the solar rays have only a feeble action, it performs no part at all; but it is only where the light is so strong as to decompose the iodide of silver wholly, after a sufficient space of time, so to speak, to effect the chemical change, that the bromide of silver is found impressed in the limits necessary to render these parts of the picture in harmony with the rest.—*Bulletin Belge de la Photographie.*

A "SPIRIT" PHOTOGRAPH.

BY DR. T.L. PHIPSON, F.C.S., ETC.

SOME years ago, a friend of mine in Bruxelles received a box of glass plates for photographic purposes. They were highly polished, quite new, and each separate plate was enveloped in two or three folds of the journal *L'Indépendance Belge*. One of these plates was taken out and prepared to receive an image. The sister of the gentleman before alluded to, sat for the picture. In course of time, the plate was developed and finished, when, to our astonishment, the whole of the image obtained was covered with printed characters, which it was not difficult to identify with those of the paper which had enveloped the plate.

The "spirit" was, in fact, *the ghost of a political article in the Indépendance Belge.*

CARBON-PRINTING.

BY A. LANDER.

PERFECT confidence in the stability of photographs printed with the salts of silver cannot be said to be established; and no one would venture to guarantee the existence of a picture ten years after it has left the hypo bath.

This instability is most probably due, mainly, to defective washing of the proofs; but even supposing the washing to have been most carefully and effectually performed—a fact the purchaser can never ascertain for himself—still the permanence of a picture cannot be guaranteed; for the atmosphere abounds in agents capable of attacking the thin metallic coating which forms the picture; and skilful chemists, such as M. Regnault (the President of the Photographic Society of Paris), even think that this metallic film may evaporate or diffuse itself in the substance of the paper.

For photographic pictures to possess a degree of permanence equal to that of engravings and lithographs, it is absolutely necessary for them to be formed of insoluble substances, as little volatile as possible, and unattackable by sulphur, ammonia, and nitrous fumes. If to these conditions we add that of the picture being of a fine black colour, similar to that of printing ink, our choice becomes limited almost entirely to carbon in powder. Seven or eight years have elapsed since the first attempts were made to produce carbon photographs; the scientific possibility of success depended upon the existence of substances which become hygrometric, or cease to be so, under the action of light, so that the parts impressed by it, or those which are not, become susceptible of fixing pulverulent matters. But until the commencement of the present year, the results attained in no respect the perfection of proofs furnished by the old processes, and possessed no value other than as curiosities.

In the month of March last, M. Charavet, photographer, of Paris, exhibited a series of carbon prints, both portraits and landscapes, which were greatly admired. These photographs, in finish and delicacy, could be distinguished from proofs taken with the salts of silver only by their permanence in the presence of nitric acid, and by the beauty of

the black tones. It was now evident that the problem of permanent photography was resolved, both in a scientific and in an artistic point of view, and that it was only necessary to discover the most practicable and economical manipulations. To enquiries as to the method he adopted to produce these carbon pictures, M. Charavet gave only evasive answers. Since then, however, he has communicated to us the theory of his process, and entrusted to us some memoranda which will enable us to afford some useful information to our readers.

The chemical principle of M. Charavet's process is, that a mixture of gelatine and an alkaline chromate, prepared and dried in the dark, becomes deliquescent and soluble in water when submitted to the action of light. This property of gelatine has been known for a long time. We cannot say who discovered it; but since the year 1843,* M. Mungo Ponton has made it the basis of positive printing, in which coloured proofs were obtained by the chromates of different metals.

M. Poitevin, well known also by his curious lithographic process, conceived in 1855 the happy idea of incorporating carbon in powder with a chromated gelatine. By spreading this mixture upon a sheet of paper or other surface, and causing the light to act upon it through a negative, and afterwards washing the impressed gelatine, the water removes all the parts which have received the action of light, and the carbon remains only in the blacks. Unfortunately, this method does not furnish half tones, because in them the surface only of the gelatine has become insoluble, and they are entirely removed by the washing, along with the pure whites.

In 1860, M. Fargier, of Lyons, discovered a remedy for this inconvenience. It consists in the application of the following process, suggested in 1857 by M. Moitessier, for transferring a picture from glass to paper. In his patent Mr. Fargier describes the manipulation nearly in the following terms:—"Upon a plane surface, such as a glass plate, spread a film of sensitized gelatine holding a carbonaceous powder in suspension, and dry it in a darkened room; then expose it to the light. Then coat the plate with collodion, and immerse it in warm water; remove the collodion from the plate, to which it adheres only at the edges, and after several washings, place it upon the piece of paper on which it is to remain."

We do not consider it necessary to enter into details to explain how, during the washing, the water acting from the thick portion to the thinner portions of the film of gelatine, and not from the thin to the thick, can preserve the half tones. We say, *can preserve*, for in fact they are not always preserved, or are sometimes too much so. The pictures shown to us by M. Fargier were extremely defective, and could not be offered for sale, for they made every person look like a negro.

M. Charavet operates by M. Fargier's process, but by improving upon it he has obtained the remarkable results which have excited our attention.

Other methods of carbon photographs appear to yield very good results, but their principle is different; it consists in the fact that the salts of protoxide of iron, with organic acids prepared in the moist way, are naturally hygrometric, and cease to be so when they have been exposed to light. A collodion glass plate, impregnated with these salts, becomes, therefore, capable, in those parts which have not received the action of light, of causing powders, spread with a brush, to adhere to those parts. M.M. Garnier and Salmon took out a patent in 1859 for this process, the principle of which was announced by Herschell in 1842. More recently, M. Poitevin has discovered the counterpart of this principle; which is, that the per-salts of iron, mixed with reducing substances, are not naturally hygrometric, but become so in the light.

To complete what relates to permanent photographs, we

must not omit to mention the labours of M. Lafon de Carmasac. Since 1855, some time previous to M. Poitevin, he obtained photographs which were almost indestructable, but he overshot the mark. Instead of seeking to make permanent photographs upon paper, he regarded the paper itself, which can endure only a few centuries, as a substance altogether too ephemeral, and constrained himself to employ only ceramic media, such as porcelain, glass, &c. The chemical principle to which he had recourse is, that bitumen of Judea, dissolved in oil of lavender, acquires (or loses?) the property of adhering to coloured powders after it has received the luminous impression. Disregarding the difference in medium, it is therefore M. Lafon de Carmasac who must be considered as the inventor of carbon-printing. But, in truth, there is no need to speak of the *inventor* of a thing which exists only through the combined efforts of several persons; and we can only regard the inventor of carbon-printing in the same light, for instance, as the inventor of the steam-engine.—*Presse Scientifique*.

STUDY OF THE WET COLLODION PROCESS.

BY M. E. REYNAUD.*

4. *The Negative riddled with pin-holes, produced during Development, and also after Intensifying and Fixing.*

The principal cause of the first of these accidents is the presence of an excess of iodide of silver on the collodion film, after sensitizing.

This excess is produced when the collodion employed contains too great a proportion of alkaline iodide, relative to the thickness of the film it furnishes; that is to say, relative to the proportion of pyroxiline dissolved. However, a collodion in these conditions cannot produce the bad results indicated above, if it be sensitized in a strong new bath. Then, in fact, the nitrate will dissolve the excess of iodide of silver, and the collodion film will be in the best possible condition. But if the sensitizing bath be already saturated with iodide, the following condition arises:—the film being too thin to retain all the iodide that is formed, part of this salt is separated under the form of extremely fine and opaque grains, which, not being dissolved by the nitrate of the bath, adhere to the surface. During the exposure to light these grains are impressed by it, and, acting as screens, they prevent the lower film from experiencing the luminous action. At the time of development, these pulverulent grains are driven off by the stream of the developing solution poured upon the plate; and thus exposing the non-impressed parts, which are transparent, they form a quantity of little holes, which being reproduced as black spots upon the positive, completely spoil it.

Moreover, these impressed and floating molecules attach themselves almost always to the film, upon which they are found spread uniformly, in consequence of the agitation communicated to the plate during development. They therefore necessarily cause a uniform veil, which destroys all transparency in the darks and all delicacy in the details.

We perceive that it is easy to remedy these accidents, as it is sufficient to that end to take care not to dissolve more than a reasonable proportion of iodides in the collodion (as indicated previously); and by replenishing, at least in part, a bath already saturated by the plates which have been sensitized in it.

We sometimes also obtain negatives riddled with small holes by another cause, which it is as well to know how to avoid. I refer to the acetate of silver, resulting from the addition, to the sensitizing bath, of a certain quantity of acetic acid. This acetate of silver, but little soluble in the nitrate, is still less so when this latter is concentrated; consequently, it will be perceived that every collodion plate, sensitized in a bath of this kind, precipitates a certain quantity of this acetate under the form of very small

* Mr. Mungo Ponton first announced his discovery in 1833.—Ed. P. N.

* Concluded from p. 427.

ystals. These crystals fix themselves in the film, and being removed or dissolved in the subsequent operations, they leave the place they occupied, vacant and thus riddle the picture with small holes. Upon examining a negative thus spoiled, by a microscope or simple magnifying glass, it is very easy to recognize the nature, and consequently the cause, of this accident.

If it be due to the precipitation of iodide of silver, the holes are irregular, and do not exhibit crystalline forms; if, on the contrary, these holes result from the crystallization of the acetate of silver, they take a crystalline form, and this character permits of our recognizing them easily.

Frequently, after developing a negative, we can perceive no signs of these points; but after strengthening and fixing, we are disagreeably surprised to see them appear, and spoil a negative supposed to be perfect. This disaster may always be avoided by employing an intensifying solution of nitrate of silver both new and weak, (about 3 per cent, at most).

For when, to turn old baths to account, we intensify with silver solutions saturated with iodide, we precipitate upon the negative—in consequence of the addition of the aqueous solution of sulphate of iron or of pyrogallic acid—a certain quantity of this iodide of silver which adheres to it, and becomes incorporated among the molecules of reduced silver; and which, being afterwards dissolved by the solution of cyanide of potassium or of hyposulphite of soda, also produces, as in the preceding cases, a negative riddled with holes.

This effect is also produced less regularly when we employ an intensifying solution of nitrate of silver freshly made but too concentrated (especially if the developing solution be new). The reduction is then made in too great abundance, and the particles of silver assume large dimensions, adhere very slightly, and are removed by washing the plate, leaving great holes in the place they occupied.

By this we perceive that, in order to obtain fine pictures, we must operate with weak solutions, and with collodions slightly iodized; in a word, we must moderate the reactions, and avoid producing them suddenly, for this promptitude is always at the expense of the fineness of the grain and the perfection of details.

5.—*Complete Fogging of the Negative.*

Many different causes may produce this unwelcome result, one most frequently encountered by inexperienced operators. I shall examine each one in succession:—

- 1st. Fogging produced by certain iodides, and by too great neutrality of the sensitizing solution.
- 2nd. That which results from a bad state of the surface of the glass plate, added to a too porous state of the collodion film.
- 3rd. That which is due to the action of light, either before, during, or after exposure in the camera obscura.

A collodion containing only iodide of cadmium, without free iodine, sensitized in a neutral bath, or in one very slightly acid, will always give fogged negatives, without this result being attributable to the action of light; for the fogging will, under these conditions, still make its appearance, although the plate be kept constantly in complete darkness.

To neutralize this property of iodide of cadmium, it is sufficient to add a little free iodine to the collodion, and a little nitric acid to the sensitizing bath. If this does not suffice, the addition of a little iodide of potassium or of iodide of ammonium to the collodion will infallibly put a stop to these abnormal reductions.

The second kind of fogging enumerated above is produced when the collodion contains pyroxyline of bad quality, or too great a proportion of alcohol. The collodion film is then too penetrable to the various liquids; and then, upon developing, a certain quantity of the iron and silver solution infiltrates between the collodion and the glass plate, and (if the plate be not perfectly clean) there results a reduction under the picture, which often entirely spoils the negative, or at

least destroys the vigour of the shadows and the beauty of the details.

A glass plate, perfectly clean and dry at the moment the collodion is poured upon it, is necessary in order to avoid this accident; and as to the proportion of alcohol contained in the collodion, we have never anything to fear in employing it in the proportion of one part to two parts of ether, as before stated.

The collodion and the baths being thus prepared and harmonized, we may always avoid the foggings described above; but if the negatives still be grey, and not transparent in the darks, or if, when viewed as *positives*, they exhibit a uniform tarnished aspect, we may then be certain that the fogging is the result of the external action of light, and we must make sure that none penetrates into the camera obscura. Lastly, we must guard against the admission of white light into the operating-room, however small in quantity, though we have nothing to fear from yellow or orange rays, coloured so by passing through glass of the proper colour.

Under these conditions, I can assure the photographer that, with a little practice and dexterity, he may certainly attain a good result in most cases; at any rate he has the means of tracing the causes of failure, and of remedying them.

The wet collodion process is unquestionably the most perfect photographic process known at present, and its applications are the most general and numerous. I believe, therefore, that, notwithstanding the numerous essays and formulæ on the subject, it was probably not unimportant to collect and classify the most frequent causes of failure. I shall have accomplished my object if some of these indications prove useful to the numerous adepts of an art, the importance of which increases daily.—*Le Moniteur de la Photographie.*

ALCOHOL IN THE SENSITISING BATH FOR ALBUMENISED PAPER—THE PHILOSOPHY OF ITS ACTION.

DEAR SIR,—No one who has even cursorily investigated the subject, can have any doubt that the belief in the possibility of coagulating dried albumen, has very much retarded the advancement of our knowledge as to what is essential for the production of the utmost brilliancy in photographic prints upon albumenised paper. That photographers—whether chemists or not—have given universal credence to this fallacy, cannot be denied with any truth, when the fact is borne in mind that not any individual amongst them has ever attempted to expose it; whilst very many of them, in England, France, and America, &c., who are men of science, are, at the present time, persistently assuming it to be a fact, and attributing to this fancied coagulation the effects which are produced from other causes.

As water is the solvent employed for the salts used in the sensitising, toning, and fixing baths, and the prints have not only to be submitted to its action in these three processes, but have also, in their final washing, to be immersed in it for several hours; and as dried albumen is also soluble in it, an absolute necessity arises that insolubility should be produced by sensitising; this the nitrate of silver accomplishes, by forming with it an insoluble compound, and the sooner it can be effected, the less will the brilliancy of the albumenised surface of the paper be impaired.

Did we use any solvent for the nitrate of silver that was not also a solvent of dried albumen, a weak sensitising bath would be sufficient, not only to form the albuminate and chloride of silver, but likewise to afford the requisite free nitrate, by a longer or shorter floating, according to the strength of the bath. Absolute alcohol not being a solvent of dried albumen, it follows, as a natural consequence, that a considerable portion of it in the sensitising bath, must diminish the solvent power of the water; therefore, the greater the strength of the alcohol, and the larger the

quantity added to the bath—not only the less silver requisite in it, but also the less time required for floating the paper: as the silver salt, from not having so much antagonistic force to contend against in the solvent power of the water, is enabled to produce insolubility by its combination with the dried albumen *sooner* than it could under more adverse conditions.

Thus, upon philosophical grounds I think it may be inferred, that the addition of alcohol to the sensitising bath for albumenised paper, will be an advantage. The Abbé Laborde's conclusions are, therefore, correct, *but not the cause assigned for them.*—Vide "Foreign Science," p. 609, of your Journal for Dec. 19th, 1862.

Unfortunately, the belief in *one* fallacy causes the promulgation of *others*; thus we find the Abbé, who is a man of science, stating, that the dried albumen "is coagulated both by the nitrate of silver *and* by the alcohol." With alcohol in the sensitising bath, we have two ingredients, *both* of which are assumed to have the power of coagulating the dried albumen; but even *did* they possess the power falsely attributed to them, *they could not act in conjunction, for the weaker power must give way to the stronger*; the alcohol, therefore, only serves the purpose of *mitigating* the solvent power of the water, *and has no action whatever itself upon the albumenised surface of the paper.*

Yours truly, GEORGE PRICE.

Mornington Road, New Cross Road, Deptford.

THE CHLORIDE OF CALCIUM BOX.*

BY CHAS. WALDACK.

SENSITIZED paper, although kept in perfect darkness, sometimes turns brown in a few hours. This alteration, which is caused by the action of nitrate of silver on the sizing of the paper, is principally observed in damp weather. Albumen paper is more liable to it than plain salted paper, and such as is sensitized with ammonio-nitrate more so than one floated on a simple solution of nitrate of silver. When kept in a perfectly dry atmosphere, however, even albumen paper floated on ammonio-nitrate of silver will keep for several days. To attain this object, use is made of the properties of *chloride of calcium*, a salt which absorbs moisture with great avidity, and which, for this reason, is used as a desiccating agent in chemical operations. The apparatus consists of a square or round zinc box with a very light-fitting cover. In the bottom of the box is put a sheet-iron pan, filled with dried chloride of calcium. Above it, and resting on a border, is a wire frame on which is laid the sensitized paper. A professional photographer should possess two of these boxes—one in which to keep his sensitized paper, and another in which to keep the prints until the time comes for toning. It is readily seen that the box should be left open as little as possible, to keep out the moisture. Perhaps some improvement might be introduced by which it would not be necessary to take off the cover every time a piece of paper or a print was put in. For instance, the cover might be pierced with a hole, on the top, through which the prints might be slipped into the box, and this hole might be shut by laying a heavy ground glass over it; or, better yet, with an easily fitting cover.

For more security against the entrance of moist air, an india-rubber band might be stretched around the joint of the large cover. After being used some time, the chloride of calcium becomes wet. When this happens, take out the sheet-iron pan containing it, and leave it on the top or in the oven of a stove until the salt is again dry. This operation can be performed over and over again without losing its quality.

It is to be hoped that some one of our enterprising manufacturers will take the matter in hand and furnish this useful apparatus to American photographers.

* From *Humphrey's Journal*.

The credit of this simple, yet useful, invention is due to Messrs. Barresuil & Davanne, two chemists to whom photographers are greatly indebted, and who have written the best work on photography in the French language.

PHOTOGRAPHIC PIRACY OF ENGRAVINGS.

GAMBART v. BALL.

THIS was an action tried before Mr. Justice Willes at the last sittings at Guildhall, when a verdict was found for the plaintiff—damages, £10.

Mr. COLERIDGE, Q.C., on Tuesday last, moved on leave reserved to enter a nonsuit, on the grounds that there was no evidence to go to the jury, and that there was no infringement of any Act of Parliament. The question arose on the right to publish photographic copies of certain prints, and whether so doing was an infringement of the Copyright Acts. The plaintiff was the proprietor of the prints, "The Horse Fair," engraved from Rosa Bonheur's picture, and of "The Light of the World," engraved from Hunt's picture. The defendant, among other photographic scraps, had sold a copy of the print, "The Horse Fair," and also a photographic copy of the other print, and the jury found that they were copies taken from the engravings themselves. The learned counsel contended that these photographic copies of the prints in question would be no infringement of the plaintiff's copyright, unless within the words of the Copyright Acts. The first of these Acts was the 8th George II., cap. 13, which gave any person who invented a design, or engraved or etched it, the sole right and liberty of printing it for 14 years. This was to protect the artist or inventor of the picture. The next statute was the 7th George III., cap. 38, which extended the provision of the former statute by prohibiting any person to engrave, print, or publish, or import for sale, any copy of a print in which any person had a copyright.

Mr. Justice WILLES.—That is a protection of engraving against engraving, not of engraving against drawing; *a fortiori*, not against a new mode of drawing.

Mr. COLERIDGE.—That was so. The next statute was the 17th George III., cap. 57, which prohibited "that any person should engrave, etch, or work, or in any other manner copy, in whole or in part, any print in which there was a copyright." This statute, the learned counsel contended, did not extend the protection against any other kind of piracy than that which before existed. The next statute was the 6th and 7th William IV., cap. 59, which extended the provisions of these Acts to Ireland. The last statute was the 15th and 16th Victoria, cap. 12, which, by section 14, extended the protection of the Copyright Acts relating to prints against lithographs or any other mechanical process by which prints or impressions of drawings or designs are capable of being imitated. The learned counsel submitted that photographs were not within the meaning or protection of any of these Acts, nor was a word said about photographs in the treaties regarding international copyrights.—Rule *nisi* granted.—*Times*.

Proceedings of Societies.

SOUTH LONDON PHOTOGRAPHIC SOCIETY.

THE usual monthly meeting of this society was held in the City of London College, on the evening of Thursday, January 8th, Mr. Sebastian Davis in the chair.

The minutes of the previous meeting were read and confirmed.

Mr. A. HARMAN, the Secretary, exhibited a couple of prints from enlarged negatives; one an architectural subject, on albumenized paper; the other, a portrait, enlarged to a full sheet of paper, from a card picture, printed on resinized paper. Both were good, the latter especially so, being well defined, delicate, soft, and artistic.

Mr. WALL, commenting on this picture, said that it proved, in a very satisfactory manner, that resinized paper could render transparency in the shadows. Some who had doubted this had mistaken the depth given by the albumen for depth and transparency in the picture.

Mr. COOPER observed, that the specimen on the table was not rolled, and that a greater amount of detail in the shadows would be apparent after it was rolled.

Mr. WALL said much misapprehension seemed to prevail amongst photographers as to the true meaning of the term "transparency," as applied to the shadows of a picture. Transparency was simply the result of detail, which carried the eye into the deepest shades. It might exist without a glossy surface at all, and might be absent, no matter how high the glaze; it was a great error to suppose that the glossy surface of albumen necessarily gave transparency. Rolling, as well as glazing, would sometimes bring out detail in the shadows not before apparent, and thus Mr. Cooper was correct in referring to rolling as a means of giving additional transparency.

Mr. HARMAN thought resinized paper would not come into use for small pictures; but for whole plates and upwards he thought the results were so much more artistic, that it would come largely into use.

After some further conversation,

Mr. COOPER said, he had recently spent a few days with Mr. T. R. Williams, at his establishment at Finchley, where the printing was done. He had there been struck with the fact that, in the method adopted, very little printing was necessary. By following the same plan, he now found that, both on resinized paper and silk, he could get good results with much less printing than he had formerly recommended. It was simply necessary to wash the prints in distilled water, instead of common water, then tone with a bath of acetate of soda and gold, which had been made a week, using it only once.

Mr. LEAKE said it was well understood that the acetate bath was better for being made three or four days, or a week, before use.

Mr. COOPER said, that in using the solution only once there was not necessarily much loss, as a very small quantity of solution might be used.

Mr. HARMAN generally used the solution seven or eight times, and liked it better after it had been used once or twice than at first, as it seemed to prevent any tendency to meanness.

Mr. G. WHARTON SIMPSON said he thought the observation made by Mr. Cooper, as to the practice in the printing establishment of Mr. T. R. Williams, was very important. He (Mr. Simpson) had often been somewhat puzzled when Mr. Williams informed him that in his establishment they over-printed very little; the depth of the print, when it left the printing frame, being very little more than what was required in the finished prints. Mr. Cooper, when there, had been printing on resinized paper and silk, and found, when using Mr. Williams's solutions, his prints, printed the usual depth, were much too dark. He thought, perhaps, that he was deceived by the quality of the light, and printed a little lighter, but the results were still too dark; and it was not until he printed to just about the depth required on the finished print, that he obtained what he wanted. It was clear that the prints lost scarcely anything in the processes of toning and fixing. After careful observation, he found that the chief difference between his own operations and those in Mr. Williams's establishment consisted in the fact that whereas at home he used common water, here they used filtered rain water. On returning home he tried distilled water, and found that it made all the difference in the depth of printing required. It would seem that the effect of water containing chlorides was to act upon the print, perhaps converting some of the minutest particles of silver, forming the image, such as those in the half tones, again into a chloride of silver, which caused the prints to be considerably reduced by the action of the hypo bath, and by this circumstance rendered necessary much over-printing whenever common water, or water containing chlorides, was used for washing before toning.

The CHAIRMAN said members would remember that some time ago he recommended the use of distilled water, and floating the print instead of immersing it, so that the free nitrate would dissolve, and by its superior specific gravity fall to the bottom of the water.

Mr. HARMAN thought such a plan would require too much time, where printing was conducted on a large commercial scale.

After some further conversation, in which the Chairman commended the subject of resinized paper as one which would well repay further experiment,

The CHAIRMAN said Mr. Simpson had handed to him a copy of the PHOTOGRAPHIC NEWS ALMANAC for 1863, for presentation to the Society. All who had seen last year's almanac, would, he felt sure, look for this one with much pleasure, as forming a most valuable and complete epitome of the science

and art of photography up to the present moment. He then called attention to some prints which had been under water for some time, in the *Colombo*. The action of the salt water had been to change the colour to a light, dirty, yellowish brown.

After some further conversation,

Mr. SAMUEL FRY read a paper on "Photography: its Retrospects and Prospects." (See p. 27). At the close of his paper, he explained that his aim had been rather, by a few brief remarks, to promote discussion, than to bring any especial views of his own before them. He thought greater things would be effected in photography if each artist were to select a given line, and stick to it, in preference to perpetually experimenting in different directions. He urged upon all photographers the effort to attain a higher artistic standard.

Mr. WALL referred to the practice of capable professional photographers, who worked down to the standard of imperfect public taste, instead of endeavouring to elevate that taste to a higher standard. Painting had once been in the same position, but had at length risen beyond it, and he hoped photography would soon do the same. He referred to a recently published work, entitled "A Painter's Tour in the Highlands," said to be written by a distinguished art critic. This book devoted a chapter to the consideration of photography as a fine art. Notwithstanding an evident disposition to be just in his appreciation of photography, it was impossible to avoid a smile at the profound ignorance of the subject manifested, as evinced in his treating as inherent faults of the art those shortcomings which were entirely due to bad lenses or bad manipulation, and overlooking the important fact that all art is subject to similar defects when in the hands of incompetent persons. The legitimate conclusion of such a line of argument would be to condemn all art for the shortcomings of artists. His object, in drawing attention to the subject, was to impress upon members that one great duty photographers owed to their art was to endeavour to make it understood in principle, as well as appreciated in result.

After some further desultory conversation,

The CHAIRMAN remarked, that whilst all photographers desired to see the art progress of photography, it should never be forgotten that it was to scientific experimentalists artists must look for the power to progress. The delicacy, roundness, and many excellent qualities which were now common in photographs, were a few years ago scarcely attainable. During the old regime of iodized collodion and pyrogallic acid, hard black and white pictures were the rule; and when the chemical conditions were such as yielded those results, artists might labour in vain. The use of bromides and iron development had placed a new power in the hands of the artists, the results of which we found in better and softer pictures. He might here suggest that it was desirable that the experimental committee should resume its labours, and especially suggested for its attention the subject of a dry process which should be as good as wet collodion.

Mr. WALL suggested that an instantaneous dry process would put a great power in the hands of the portraitist, who would then have a plate ready for exposure at any moment. The great superiority of the higher class of portrait painters over others did not generally consist in the superiority of their drawing or colouring, so much as in their power to embody character. Such men would think nothing of engaging the sitter for half an hour or an hour in conversation, watching for the right expression before they touched the canvas.

Mr. SIMPSON remarked that, valuable as the suggestion might be, he feared it was scarcely applicable to photography, especially as now practised. The tendency of the day was to rapid production in large quantity. He feared that any suggestion for the art progress of photography, which was inimical to its commercial success, would scarcely obtain much attention. Again, as to the use of dry plates, however valuable instantaneous dry plates might be to the tourist, they would scarcely be used under any circumstances by the portraitist. The photographer who at all knew his business, had, in the wet process, such a safe, certain, ready, rapid, and satisfactory power, that he would not be likely to exchange it for the inevitably lengthy manipulations of the most perfect dry process. As to having a plate always ready, that was easily managed. In one of the largest and best managed portrait establishments in London, which he knew, the custom was, during the season, for an operator to commence coating and exciting plates from the first thing in the morning until evening, without any inter-

mission, so that a wet plate was ready at any moment the artist might require it.

Mr. WALL thought that the commercial interests of photography should be subservient to its art progress.

Some conversation followed, in which the Chairman, Mr. Fry, Mr. Leake, and others, thought that no advantage would be gained by the use of dry plates in the studio, and that portraitists would never abandon the wet process. A desultory conversation on the possibility of keeping wet plates for twenty minutes or half an hour in the dark slide, during the arrangements of portraiture, followed, many precedents being quoted in support of the practice.

The Rev. F. F. STATHAM made some interesting remarks on the phases of photography, illustrated at the International Exhibition. He referred to the variety of style which might be introduced into portraiture—referred, for example, to the productions of the Dutch painters, in which portraits were produced as character pictures, so that they were interesting and valuable as works of art long after the individuals portrayed were forgotten.

Mr. SIMPSON had been reminded, by some remarks of Mr. Statham, in reference to card pictures of landscapes, of one he had just received from an anonymous correspondent, which he wished members to examine as one of the most perfect small pictures he had ever seen. It was a view of Edinburgh, from Calton Hill, in which every part of the foreground was most perfectly and brilliantly defined, and yet fine natural clouds were secured in the sky. He had no information as to how it was produced, except that it was on a Fothergill plate. He did not know by whom it was produced; but, from collateral evidence, he was disposed to attribute it to Mr. Archibald Burns, of Edinburgh, a well-known skilful Fothergill manipulator.

After some further conversation, Mr. FRY, at the call of the Chairman, said, that the able remarks of Mr. Statham had quite cut the ground from under him for further comment. There was first one subject to which he would refer. It would be within the recollection of members that, two years ago, he read a paper before this society, on printing in skies, and other forms of double printing, with a view to artistic effect. It met with some opposition, and was, in fact, manifestly a premature paper—one which photographers were not then ready for. He was very happy in being able to call attention to many prints in the Photographic Exhibition (which would open in a few days), in which photographers, of undoubted skill and reputation, had adopted the system referred to, and with manifest advantage to their pictures.

The CHAIRMAN proposed that Mr. Simpson be requested to ascertain the artist who had produced the charming little card landscape they had been examining, and the terms at which a sufficient number could be procured, in order that each member of the society might have in his possession a picture which might serve as a standard for imitation. This was carried by acclamation.

Mr. LEAKE called attention to two pieces of lead pipe, quite eaten through by the vapours of acetic acid.

Mr. STATHAM suggested that the society should keep a Desideratum Paper, on which should be entered, from time to time, a note of all the especial wants which occurred in the art. Such a memorandum would preserve a record before the eye, of things which would often otherwise be forgotten.

It was announced that, at the next meeting, Mr. George Price would read a paper on the Theoretical Principles of Positive Printing. The proceedings then terminated.

The International Exhibition.

REPORT OF THE JURY ON PHOTOGRAPHY AND PHOTOGRAPHIC APPARATUS.*

THE PRINTING COMMITTEE.

CIRCULAR letters were addressed by the committee to photographers of experience and reputation, asking them to assist in the purposes of the inquiry by information and suggestions, and also by contributions of prints, with particulars of the method of producing them, in order that the fullest experiment and examination might be made. The results of this inquiry were furnished in the following Report:—

"Evidence of Permanence.

"The Committee have unquestionable evidence of the existence of Photo-

* Continued from p. 21.

graphs which have remained unaltered for more than ten years, prepared by salting plain paper with a chloride, afterwards making it sensitive with either nitrate of ammonio-nitrate of silver, fixing with a freshly-made solution of hyposulphite of soda and washing in water; also of positives produced by Mr. Talbot's negative process.

"They have not been able to obtain evidence of photographs having been prepared at all upon albumenized paper, or coloured with a salt of gold or fixed with "old hypo" so long ago as ten years.

"They have, however, ample evidence of the existence of unaltered photographs so prepared, five, six, and seven years ago.

"They have not found that any method of printing which has been commonly followed, will necessarily produce fading pictures, if certain precautions be adopted, nor have they evidence that any method which has been adopted, will not produce fading pictures unless such precautions are taken.

"Causes of Fading.

"The most common cause of fading has been the presence of hyposulphite of soda, left in the paper from imperfect washing after fixing.

"The Committee think it right to state, that they have been unable to find any test to be relied upon, which can be used to detect a minute portion of hyposulphite of soda, in the presence of the other substances which are obtained by boiling photographs in distilled water, and evaporating to dryness; yet they have no doubt of the truth of the above statement, from the history given of the mode of washing adopted.

"The continued action of sulphuretted hydrogen and water will rapidly destroy every kind of photograph; and as there are traces of this gas at all times present in the atmosphere, and occasionally, in a London atmosphere, very evident traces, it appears reasonable to suppose that what is effected rapidly in the laboratory, with a strong solution of the gas, will take place also slowly, but surely, in the presence of moisture, by the action of the very minute portion, in the atmosphere.

"The Committee find that there is no known method of producing pictures which will remain unaltered under the continued action of moisture and the atmosphere in London.

"They find that pictures may be exposed to dry sulphuretted hydrogen gas for some time with comparatively little alteration, and that pictures in the colouration of which gold has been used, are acted upon by the gas, whether dry or in solution, less rapidly than any others.

"They also find that some pictures which have remained unaltered for years, kept in dry places, have rapidly faded when exposed to a moist atmosphere.

"Hence it appears that the most ordinary cause of fading may be traced to the presence of sulphur, the source of which may be intrinsic from hyposulphite left in the print, or extrinsic from the atmosphere, and, in either case, the action is much more rapid in the presence of moisture.

"Mode of Mounting Photographs.

"The Committee find that, taking equal weights, dried at a temperature of 212°, of the three substances most frequently used, viz.: gelatine, gum, and paste, the latter attracts nearly twice as much moisture as either of the former; and, as in practice, a much smaller weight of gelatine is used than of gum, gelatine appears to be the best medium of these three; and the Committee have evidence of fading having, in some cases, been produced by the use of paste.

"In illustration of some of the circumstances alluded to above, the Committee think it well to mention some instances of prints at present in their possession.

"Out of several prepared together in 1844, three only are unaltered, and these were varnished soon after their preparation with copal varnish.

"Half of another print of the same date was varnished, and the other half left; the unvarnished half has faded, the varnished remains unaltered. Three pictures were prepared in 1846, all at the same time, with the same treatment: when finished, one was kept unmounted; the other two were mounted with flour-paste at the same time, one of these latter having been first coated with Canada balsam; at present, the unmounted one and the one protected with the balsam are unaltered, whereas the other has faded.

"A picture prepared in 1846 was so exposed that the lower part of it became wetted with rain; at present the part so wetted has faded, while the rest of it remains unaltered. Several pictures were prepared and mounted about ten years ago, and kept in a dry room for about three years without any change, after which they were placed in a very damp situation, and then faded decidedly in a few months.

"The Committee propose very shortly to actually test the durability of the various modes of printing, by exposing pictures to different treatment, and they have been fortunate enough to obtain a grant of space for this purpose from the Crystal Palace Company.

"The Committee make the following suggestions, arising out of the above Report:—

"1. That the greatest care should be bestowed upon the washing of the prints after the use of hyposulphite of soda, and for this purpose hot water is very much better than cold.

"2. The majority of the Committee think that gold, in some form, should be used in the preparation of pictures, although every variety of tint may be obtained without it.

"3. That photographs be kept dry.

"4. That trials be made of substances likely to protect the prints from air and moisture, such as caoutchouc, gutta-percha, wax, and the different varnishes."

CARBON PRINTING—THE DUC DE LUYNES' PRIZE.

The methods of printing, toning, and fixing photographic pictures had up to this period not undergone much modification since their original discovery.

An image formed by the action of light upon paper prepared with the chloride of silver and fixed by means of a solution of hyposulphite of soda was found to be tolerably permanent, but its colour, a reddish brown, was unsuited to the purposes of pictorial effect. The addition of chloride of gold to the fixing solution aided in producing a variety of purple black and neutral tints, which were much more agreeable and satisfactory. This addition, however, introducing an element of decomposition in the fixing solution, was thought by many to increase the chances of fading. To avoid this difficulty a new method has been proposed, in which the toning of the print by means of a solution of gold is conducted prior to the process of fixing by means of hypo-

sulphite of soda. This was considered an important step in the securing of permanency, and it is believed that photographs, produced with an intelligent regard to known laws, and preserved with a care due to works of art, may be considered as permanent. Although it is an undoubted fact that the phenomenon connected with the printing, toning, and fixing of photographs, so as to secure under all conditions entire permanency, still presents more points for anxious examination and inquiry to the scientific photographer, yet the fact that there are in existence many photographic prints which have remained unchanged for upwards of twenty years, proves, beyond all doubt, that the causes of fading are not inherent, but accidental, and that they only require to be better understood to be entirely removed.

The desire for absolute certainty as to the permanency of prints from photographic negatives has led to many attempts to substitute other substances for the salts of silver usually employed.

In the year 1856 a French nobleman, the Duc de Luynes, in order to give an impetus and a definite purpose to efforts in this direction, offered a prize of 2000 francs for the most perfect process of printing in carbon, two years being allowed for competitors to complete their researches in.

It was agreed that carbon being of all substances known to the chemist one of the most stable and unaltered, it was manifest that if it could be used for producing the blacks of the photographic design, the same guarantees would then be obtained for the permanency of photographs which exists for the stability of printed books and engravings, and that such a consummation was all that could be hoped or desired. Several competitors responded to the appeal thus made, and a commission of gentlemen was formed in the year 1858 to report upon the processes submitted by the respective claimants for this prize.

The report was made in the year 1859, in which it was stated that no process submitted at that time was sufficiently perfect to merit the entire award. The nobleman who had instituted the competition then intimated his willingness to allow the offer to stand over for three years more, at the same time allowing the commission to divide the 2000 francs amongst the various gentlemen who had best contributed to the end in view—the production of permanent prints. Two gold medals, each of the value of 600 francs, and two silver medals, each of the value of 400 francs, were then awarded. A gold medal was given to M. Poitevin, as the originator of the first idea upon which carbon processes were based, viz., the peculiar action of light upon a combination of salts of chromium and organic matter. A gold medal was awarded to Messrs. Divanne and Girard for their investigations into the causes of instability in silver prints. A silver medal was awarded to Messrs. Garnier and Salmon, for a process of printing in carbon. The other silver medal to Mr. Poncey, an Englishman, for a similar process. The commission appointed to decide upon the second competition have recently made their report, and have awarded to M. Poitevin the prize of 2000 francs, and an additional medal, value 600 francs, to M. Farzier for his process. Specimens of each of these artists' works are in the Exhibition.

Notwithstanding the fact that great progress has been made, much still remains to be desired, and a further prize is again offered by the Duc de Luynes, to be awarded in 1864, and it is still open to competition.

In referring to this interesting portion of the history of the art, and according high honour to the nobleman by whom it was initiated, there remain one or two remarks to be made.

It would be manifestly beside the purpose of this report to enter into an examination of the claims for priority of invention made by various experimentalists; but it is impossible to refer to the matter without drawing attention to the fact that the germ of all these processes was the discovery of an Englishman. In May, 1839, Mr. Monge Pouton communicated to the Royal Scottish Academy of Arts his discovery of the action of light upon paper, prepared with a solution of bichromate of potash, a discovery upon which the carbon processes and the majority of the photo-engraving and photo-lithographic processes have been based.

(To be continued.)

Correspondence.

FOREIGN SCIENCE.

[FROM OUR SPECIAL CORRESPONDENT.]

Paris, 14th January, 1863.

A PROCESS for obtaining paper positives and negatives, with nitrate of silver alone, is announced by M. Gaumé, of Mans. He employs a nitrate solution of the strength of 4 or 5 per cent., upon which the paper is floated 4 or 5 minutes, then dried in a dark place. The exposure in the camera must be about 20 or 30 seconds for negatives, and several minutes for positives. Both negatives and positives are developed with gallic or pyrogallic acid, without the addition of silver. They are toned with chloride of gold, and fixed in rain water. The same results may be obtained upon albumenized paper, without iodide or chloride, and the proofs are remarkable for their delicacy. By this process, therefore, pictures are obtained with nitrate of silver only. M. Regnault considers that it will be more prudent to fix with ammonia, as recommended by M. Humbert de Molard.

Mr. Maxwell Lyte has pointed out a cause of fading in paper positives which has not hitherto been noticed, viz.:—the presence of sulphur in the Bristol boards, &c., used as mounts. In paper manufacture, the pulp is bleached by the action of chlorine, and to remove all traces of this bleaching agent, manufacturers frequently put into the vat,

under the name of *anti-chlor.*, a certain quantity of hyposulphite of soda. But this substance acts only on condition of being decomposed by the chlorine, and the products of the decomposition of the hyposulphite of soda, eminently unstable, always cause the liberation of a certain quantity of sulphur, which remains in the pulp, sometimes in so considerable a quantity that it is literally possible to extract the sulphur by sublimation. Besides the sulphur, there is always a slight excess of hyposulphite of soda, and it need cause no surprise when we see proofs mounted upon certain kinds of cardboard, show the fatal yellow stain, while other proofs, prepared under exactly similar conditions, remain intact if not mounted.

Therefore, in mounting proofs we encounter numerous causes of fading, either from the presence of free sulphur, or of an excess of hyposulphite of soda, or of chlorine, or of hypochlorite of lime, or even from the chloride of sodium, resulting from the decomposition of the hyposulphite of soda by chlorine.

We may easily detect the presence of hyposulphite of soda, chlorine, and the chlorides, by the following experiment:—

Beat up a piece of the suspected card-board in a porcelain or glass mortar with distilled water; to one portion of the filtered liquid add a crystal of nitrate of silver, which in the course of a few minutes, gives, when sheltered from the action of light, a yellow, or even a black, precipitate, if any traces of hyposulphite of soda be present. In the other portion of the liquid, previously acidulated with a little nitric acid, and boiled, also put a crystal of nitrate of silver, which, if chlorine or chlorides be present, gives a white precipitate of chloride of silver.

The detection of free sulphur, rather more difficult, is made by attacking the paste of the card-board with *aqua regia* entirely free from sulphuric acid, after the evaporation of the greater part of the liquid, and the incomplete saturation of the excess of acid by a little ammonia. Then add some distilled water, and filter; the presence of sulphuric acid in the clear diluted liquid, is recognised by chloride of barium.

A successful mode of treating the ashes arising from the burning of photographic paper clippings, &c., consists in the following:—the papers are first burned in a laboratory furnace; the ashes, left undisturbed for several hours, gradually consume all the carbon; they are then collected together, weighed, and melted without any other treatment. After some comparative experiments made upon 150 grains of ashes, the following proportions have been adopted:—

Ashes	10 parts.
Carbonate of soda (dried)	5	"
Pure silica sand	2	"

The addition of the silica appears indispensably necessary. We thus obtain a very fluid nitreous slag, with a comparatively low temperature. The grains of silver are easily collected together, and the very compact matter thus obtained dissolves perfectly in nitric acid diluted with its own volume of water. The gold mingled with the silver remains in the capsule in the form of a black powder.

Generally the ashes of the refuse papers of the operating room arising from filtering papers, clippings, &c., yield from forty to fifty per cent. of their weight of silver.

M. Gaudin, the editor of *La Lumière*, has published his Photographic Programme for the current year, in which he points out the subjects deserving the especial attention of photographers, and to the investigation of which he intends devoting himself. First in importance stands a *sensitive dry collodion*. The defect in this is due entirely to the cohesion the collodion acquires in drying, which transforms it into a horny substance of a greasy nature, which does not permit aqueous liquids to penetrate it to react upon the impregnated iodide of silver it contains. Collodion which has never ceased to be wet, may be regarded as forming spongy film composed of extremely fine fibres interlaced, and acting as a support to the iodide of silver. This is, at least, what

takes place in employing the ordinary silver bath of eight or ten per cent., with a weaker bath, of two per cent. for example; the iodide of silver is produced only on the surface of the collodion, forming a continuous pellicle; unfortunately this pellicle does not adhere, and becomes detached in spots, leaving the collodion bare, and consequently perfectly transparent. From a present point of view, this is to be regretted, for we well know that a sensitive coating, which can be applied to the whole surface of the collodion, will not be protected from the developing agents by the drying of the subjacent collodion.

From this it is clear that a dry collodion composed of perfectly rectified ether and alcohol; will be less porous and less sensitive than a collodion prepared with alcohol and ether a little aqueous. In drying the first will become compact and nitreous, while the second will be very porous; but also, its cohesion will be feebler, and it will scarcely bear the numerous operations consequent upon developing the pictures, unless it be placed on a glass-plate previously covered over its entire surface with a very dilute coating of albumen; a simple edging of albumen being insufficient in this case.

Glycerine in collodion appears to act in the same manner as water, but it is probable, that in putting it on to a washed sensitized collodion, it acts like tannin, by lodging in its pores. As to inertness, and permanence of the humid state, it holds the first rank, and if we had not to fear the adherence of dust, it would, perhaps, be superior to tannin, as it carries with it a certain power of reduction, which is called into play every time the iodide has been impressed by light, however little, during the preceding operations.

The Developing Bath of Proto-acetate of Iron.—Thus far I have found nothing comparable to proto-acetate of iron for the development of negatives. The proto-nitrate is much too difficult to preserve, from its tendency to precipitate the silver in a white state. It is valuable for direct positives, but the pictures are always a little granulated, while the proto-acetate of iron, which gives, it is true, a yellow metallization, produces a delicacy equal to that given by pyrogallie acid. The great advantage to be derived from the employment of proto-acetate of iron, is that of producing in the negative a black proportionate to the intensity of the light, which has acted upon the collodion; an advantage which it does not share with any other developer. Sulphate of iron, for instance, never gives skies which can be printed uncovered, at the first pouring on, but require intensifying. During my latest researches, I have been prevented from employing the proto-acetate of iron which I had prepared, because it always produced a general inky blackness over the whole plate, without any picture; but I shall soon discover the cause of this singular obstacle, which is doubtless caused by some organic matter inherent to the products used in its preparation.

Preparation of Photographic Cotton by Nitrous Gas.—I have already made an experiment to prepare photographic cotton by the action of nitrous gas: the effect was *nil*. I ought not to have expected to succeed, for previously I had failed to obtain any result upon passing this gas through several folds of rag; but I did not think the intervention of water was necessary to this reaction; the idea occurred to me only during my last experiment. I have now no doubt that moistened cotton will produce the desired result; it would greatly surprise me if it did not. In the event of success, it is easy to perceive the great facility that would result in the preparation, on a large scale, of a product so extensively employed at the present time, and I see a means of obtaining it more easily and with less variable properties.

Mofication of Organic Substances, mixed with various Salts, under the influence of Light.—The mixture of alkaline bichromates, by which certain organic substances become insoluble by the action of light, is the first step on a boundless path. Quite recently it has been asserted, that any organic matter, the juice of walnut-peels, for instance,

becomes, without any addition to it, black and insoluble under the action of light. I have thought it necessary to notice this statement, which appears to me very extraordinary, because an operator asserts that he has obtained proofs by this means. For lack of walnut-peels, I have prepared a decoction of walnut leaves, without being able to recognize any photogenic property in this decoction when spread upon paper. Until proof is afforded to the contrary, I shall suspect that there is some error in this statement; but we must restrain our incredulity in remembering that even the illustrious Arago was too hasty in imposing limits to the power of photography.

Carbon Printing.—The highest aim of photography is to arrive at results in which durability shall rival perfection. In taking proofs with lamp-black upon ordinary paper, we seem to have attained this aim. Such, however, is not our opinion. It seems to be possible to obtain upon a steel plate, suitably coated, an engraving by the action of light solely, and to be able to print a small portrait with a black mineral ink, on asbestos paper with a suitable vitreous mixture, so that, after being subjected to a red heat, we shall possess indestructible pictures, so long as they are not exposed to the heat of a forge.

PHOTOGRAPHY ON CANVAS.

Ghent, Belgium, January 4th, 1863.

DEAR SIR,—In your number of January 9th, I find a letter from Mr. J. T. Lucas junior, by which he claims to have made perfect photograpis on canvas in March 1859.

Allow me Mr. Editor to give you a few dates relating to this matter.

It is, to my knowledge, that in 1855 or 1856, Mr. Charles Fontayne (of Porter and Fontayne, photographers, Cincinnati, O.) experimented on canvas coated with iodized albumen. I know of no particulars about it.

In April 1856, Mr. J. H. Tatum of Baltimore, M.D., patented a process which gave but indifferent results. The canvas was treated with alkali, then with chloride of sodium, after which it was silvered, exposed to light, and fixed with hypo. Finally flowed over with a very diluted solution of sulphuric acid.

In 1858, the exact date I cannot tell, Mr. Marinus Sanier communicated to the *American Journal of Photography* a process which I tried with success in the winter of the same year. The canvas was cleaned with a solution of cyanide of potassium and well rinsed, then coated with diluted iodized albumen, sensitized with aceto-nitrate of silver, developed with gallic acid, and fixed with hyposulphite. The great drawback to this process is, that a thin film must be used or it will crack after painting, and a thin film gives less success than a thick one. This evil was remedied by substituting gelatine for albumen. From the moment I made this alteration, I worked with constant success.

I may at a future time, and with your permission, give you a description of the process in all its details. Until of late, having made a special business of photography on canvas, I considered the process as a *trade secret*, and have only communicated it to a few friends.—Yours, respectfully,

CHARLES WALDACK.

From Cincinnati, Ohio U. S.

[We shall have much pleasure in learning the details of Mr. Waldack's method of working on canvas.—ED.]

THE PRESERVATIVE QUALITIES OF CAOUTCHOUC.—We quote the following interesting notice from the *Chemical News*:—*Wood for Ship Building.*—Professor Crace Calvert is now making an investigation for the Admiralty of different kinds of wood used in ship building. It appears that the professor is at no loss to explain why so many of the fleet of recently built gun-boats became rotten and others escape untouched. He finds the goodness of teak to consist in the fact that it is highly charged with *caoutchouc*; and that, if the tannin be soaked out of a block of oak it may then be interpenetrated by a solution of *caoutchouc*, and thereby rendered as lasting as teak. Of the durability of teak there can be no question.

To Correspondents.

* * * Wanted, for full prices, or in exchange, the following numbers of the PHOTOGRAPHIC NEWS:—76, 80, 81, 91, 101, 197, 198, 200, 202, 203, 213, 214, 215, 216.

F. P.—It is by no means absolutely necessary that transparencies for the magic lantern should be taken on albumen. The advantage claimed over collodion is greater brilliancy, sharpness, and richness of tone. By skillful manipulation, and careful choice of process, collodion transparencies may be made to imitate those on albumen very closely. Those who prefer the tone of albumen will find the tannin process gives very similar results. If you wish to try the albumen process you will find various articles with full details in the back volumes of the NEWS. We can only briefly state here that the albumen is prepared with an iodide and a bromide, the same as collodion, the plate is coated and allowed to dry, then excited in a bath of aceto-nitrate of silver, washed and again dried, and then exposed. With dry plates, printing by superposition, as in paper printing, is a common practice, giving a short exposure and then developing; no toning is needed with albumen. If wet collodion and camera printing be used—and excellent transparencies may be so produced—then the negative must be placed in a groove of a box or a camera so that no light shall enter the camera or reach the sensitive plate except through the negative. Various articles on transparencies appeared in our last volume.

H. P.—Your letter is not quite clear as to what part of the plate presents the "silvered" effect to which you refer. So far as we can judge from your description it is from abnormal reduction, or fogging, and may proceed from a variety of causes, which, without seeing the result, we cannot certainly point out. It may be over-need collodion, or diffused light, or the bath. Most probably the latter. Try adding a little bicarbonate of soda in solution, until a precipitate begins to be formed. Then expose a few hours to light, filter, and add a little nitric acid. If the defect arise from the bath, this will most probably cure it. 2. The time required for fixing prints in a fresh solution of hyposulphite of soda, one ounce in five of water, is about a quarter of an hour or twenty minutes.

H. S.—The defect is an unusual one, or, rather, it has presented itself in an unusual degree. It is probably due primarily to the quality of the paper, which is unusually absorbent. The defect arises from partial absorption and unequal drying of the albumen, the portion not dried then flowing over that which is dried, and causing what are technically called by albumenizers, "curtains." Newness of the paper, the size not being thoroughly hardened, will cause it. The albumen, in this case, partially dissolves the size, and the two mingling together produce the unequal surface. The extremely absorbent character of the paper is shown by moistening the back; the moisture is absorbed and disappears at once. The sample sent you tastes strongly of the salt, at the back, showing that it has been thoroughly absorbed. This would readily account for the difficulty. The suggestions we may make are: use undiluted albumen, and add neither ammonia, nor anything else but the chloride; see that the paper is thoroughly dry; float a very short time, scarcely more than drawing the sheet over the surface of the albumen without allowing it to remain at all; try some of the recent suggestions for making the paper waterproof previous to albumenizing. Or get another older, harder, less absorbent paper.

SIGILLI.—We will try your bath and report next week.

A. B. C. will oblige us by communicating his address, and the terms upon which he can supply a few dozens of the exquisite view of Edinburgh from Calton Hill, with any other particulars. See our report of the last South London Meeting.

D. A. proposes to coat plates with collodion and allow them to dry, subsequently exciting, &c., in the field, for use. We fear very little would be gained in convenience, and something would certainly be lost in several ways.

L. E. W.—You can register and secure the copyright of a photograph of an oil-painting; but that does not interfere with the right of others to copy the painting if they have an opportunity. It only secures your photograph from being copied.

E. W.—The article to which you refer contained an extract from Mr. Sutton's Notes. It was he who proposed to send a sample of the paper, in which he was interested, to readers of the Notes. We believe that such a sample was given with the Notes of January 15th.

MICHAEL LOAM.—The manipulations in making collodion are best effected in the following order:—First, add half the alcohol to the cotton, and let it get well saturated with it; then add the ether, and shake until all the cotton is dissolved. Now, let it stand for a day or two, and either decant or draw off with a siphon the clear collodion from the residue. In the remaining half of the alcohol dissolve the iodides and bromides, if necessary, grinding them with a little alcohol in a mortar of glass or Wedgwood ware. When dissolved, filter; and then add the proper quantity of the filtered solution to the clear collodion.

H. GOBLE.—We cannot recommend you to tone and fix in one bath, by the old method. But, if you do so, always use the solution fresh made, thus:—1 ounce of hyposulphite of soda, 1 grain of chloride of gold, and 4 ounces of water, adding a piece of borax the size of a walnut for each pint. Do not add silver, or anything else. Or you may use the bath of *sel d'or*, thus:—1 grain of gold, three grains of hyposulphite of soda, and 4 ounces of water, afterwards fixing in a fresh strong solution of hyposulphite. 2. The backgrounds in Messrs. Southwell Brothers' studio, are generally of a somewhat dark grey.

A SUBSCRIBER FROM THE BEGINNING.—We believe the best lenses in the world are made by the two English makers you name, and their lenses are chiefly used by good London artists. We do not know any foreign lenses which surpass them.

A NOVICE ON THE CONTINENT.—The only journal of general character devoted solely to chemical science is the *Chemical News*, edited by Mr. W. Crookes, published weekly, price 4s., at No. 1, Wine Office Court, Fleet Street. There are monthly journals, which are simply organs for recording the transactions of the societies to which they belong, such as the *Pharmaceutical Journal*, monthly, 1s.; and the *Journal of the Chemical Society*,

monthly, 1s. The *Philosophical Magazine* contains, occasionally, some chemical articles, monthly, 2s. 6d. There are several good chemical journals published on the Continent, amongst which we may name the *Comptes Rendus*, and the *Reperoire de Chimie, Pure et Appliquée*. 2. Black varnish is sometimes used for stopping out skies. If you cannot purchase it ready, brunswick black, diluted with turpentine, will answer. Water colours, such as lamp black ground in gum water, are sometimes used. We don't like stopped-out skies.

L. M. B.—Your picture is exceedingly creditable for an amateur. The chief improvement it would bear would consist in a trifle more exposure and less intensifying, this would make it a little softer. We are glad you profit so much by reading the NEWS. A little more practice will make you perfect.

C. F. W.—The book was sent. We shall look forward with interest for your promised communication.

GILLARD.—A report on your glass in the "Scientific Gossip." We have not yet seen any of the pictures referred to, but we have good reason to believe they are not photolithographs. We have been told they are vile diminutive photographic copies. But we confess that we, in common with others, are puzzled by the advertisement.

JOHN MARTIN.—The glass was so broken that we could not form an opinion of it. 2. The difference between the samples of acetic acid is that one really is glacial, and should freeze at 50°, the other is not, but is largely diluted and possibly impure. 3. We do not see any reason why photographs taken with the pistolgraph should not answer for the oxy-hydrogen microscope if care be taken regarding the definition. 4. We do not know which rolling-press you especially refer to, but, as a rule, the larger ones give a heavier pressure. We believe some of the smaller ones answer very well.

A CONSTANT SUBSCRIBER.—There is no obligation upon persons publishing registered photographs to have the fact announced on the print, but we think it would be advisable to do so. The mere fact of printing "registered" upon the photograph would be no proof, however, that it was copyright. The presumption is, that the copyright of all photographs belongs to somebody, whether protected by regular course of law or not, and that it is the duty of persons wishing to copy them for their own purposes to ascertain how far they are permitted to do so, or otherwise run the risk of piracy. The only method of ascertaining whether a picture is protected or not, is to enquire of the publisher, or search at Stationers' Hall, on paying the proper fee.

CHELTENHAM.—Your cards appear to have stood very well, but an exposure during four months is not a very severe test. The chief improvement required is a little more brilliancy and better definition. You will find valuable printing formulae in our ALMANAC, just published. You will find instructions for ammonia-nitrate there, and also repeated in the last volume.

AMICUS.—In the case stated, where an operator works for you at a regular salary, using your chemicals, &c., on your premises, &c., there cannot be a doubt about it that the negatives, taken belong to you, unless there were a direct bargain to the contrary. The fact of the camera belonging to the operator does not in any way give him a claim to the negatives.

R. M.—We are obliged by the interesting paragraph. The plan of taking a photograph in several pieces, and joining them, is not, however, new.

XENOPHON.—It is unquestionably philosophically right to reverse the lens in enlarging, so that the transit of the rays through the lens shall be after the same manner as in ordinary operations for which the lenses are constructed. We have not, however, noticed any practical disadvantage from neglecting to reverse.

THOS. COLLINS.—In Mr. Warner's remarks in reference to securing clouds with Dallmeyer's No. 1, triple, on a plate 10 by 6, there is no discrepancy. The No. 1 triple gives a circle of light twelve inches in diameter; and we have seen respectable pictures on a 10 by 8 plate taken with it. Many operators work on a plate 10 by 8 with this lens, and subsequently cut the print to whatever dimensions may suit it best. 2. We believe it an error to suppose that the triple, or ordinary double lenses, give less brilliancy than single lenses. Some of the most brilliant pictures we have ever seen have been taken with the triple. As for double lenses there cannot be a doubt as to the brilliancy of the image. 3. We have found no disadvantage from the use of an ebonite bath. 4. The sixth volume of the *Chemical News* has just been issued, we believe. It is published in Wine Office Court, Fleet Street.

PERPLEXITY.—The most palpable error in your operations, is the use of 20 drops of nitric acid in an ounce of developing solution. Try again with 2 drops. Your collodion being old and red may be insensitive. Try some fresh. Also try a better light if you can, the open air for instance. It is very probable from the appearance of the positive, which arrived in fragments that your bath is out of order. Make a solution of bicarbonate of soda, 10 grains to an ounce of distilled water; then add a few drops at a time to your bath until a precipitate begins to fall. Now place the solution in sunlight for a few hours; then filter, and add a drop of nitric acid to each four ounces of solution. It will probably work bright and clean, if not, add about as much more nitric acid, then try. Let us know of the result, and we will, if necessary, try to help you further.

TYRO R.—You will easily ascertain if you have too much of the roof over the head of the sitter darkened, by bringing him forward a little and trying a picture. We should be disposed to remove the yellow calico at the sides entirely. The general arrangements seem good. We could judge better by seeing a picture taken with the unsatisfactory arrangements.

Henry Regnier, Charles Derby, J. W., M. C., and several other correspondents in our next.

PHOTOGRAPHS REGISTERED DURING THE PAST WEEK.

By MR. JOHN STUART, 120, Buchanan Street, Glasgow.

1. Right Rev. Bishop Murdock.
2. Rev. James Knox.
3. Rev. James McNaught.

All Letters, Works for Review, and other Communications for the Editor, should be addressed to the Office, 32, PATERNOSTER ROW, LONDON.

THE PHOTOGRAPHIC NEWS.



Vol. VII. No. 229.—January 23, 1863.

CONTENTS.

	PAGE		PAGE
Excess of Density in Iodide of Mercury Negatives	37	The Application of Photography to the Magic Lantern, &c. By Samuel Highley, F.G.S., F.C.S., &c.	43
The Photographic Exhibition—Second Notice	37	International Exhibition.—Report of the Jury on Photography and Photographic Apparatus	45
The Discovery of the Metal Thallium	38	Correspondence.—Foreign Science, &c.	46
Photographic Chemicals, their Manufacture, Adulteration, and Analysis.....	39	Notes and Queries	47
Printing Difficulties. By a Photographer's Assistant.....	40	To Correspondents.....	48
On the Formation of the Photographic Image, &c. By M. Omme-ganck.....	41	Photographs Registered during the Week	48
On Photolithography. By Andrew Maectear	41		

EXCESS OF DENSITY IN IODIDE OF MERCURY NEGATIVES.

WE are enabled to relieve the minds of many of our readers from an apprehension, which has been felt of late by photographers using bichloride of mercury and iodide of potassium, for intensifying their negatives. This process has been very extensively used during the last year, or since the method of using it, with great success, as practised by the late Mr. Lacy, was published in our columns. During the past summer a conviction has been gaining ground that the effect produced was not permanent. The deposit of iodide of mercury, in combination with the silver image, was found to darken gradually under the action of intense light, so that if the right amount of intensity were gained at first, the negative gradually became hard during the course of continued printing.

All photographers are familiar with the fact that a silver image, treated with bichloride of mercury, has a tendency to darken under the action of light. Neither the salt of mercury alone, nor the reduced silver, darken by light; but it is probable that some trace of chloride of silver is formed upon which light acts. Iodide of mercury alone, in like manner, is not darkened by light, but the deposit, formed by its action upon a negative, is found, under some circumstances, to change under the action of light and become darker. What is the precise nature of the change is uncertain; nor has the fact itself excited much attention until recently. Mr. Lacy was in the habit of urging, as an advantage attending the process, that the negative became a little more brilliant, after once or twice printing, the sparkling points of high light becoming more pronounced and definite. In his experience, however, the negatives did not become hard. Mr. Hughes, who became his successor in business, found, on printing some thousands of copies from the royal negatives of Mr. Lacy, that they became, in process of time, so much denser and harder that they were comparatively useless.

The subject has several times, recently, been discussed at the South London Society, where the evidence on the subject has been somewhat discrepant and varying. Mr. Blanchard has held that this change only took place when pyrogallic acid and silver, as well as bichloride of mercury and an iodide, had been used in intensifying, and has maintained the idea that it was to the presence of some trace of iodide of silver the darkening was due. Mr. Harman, and some others, had found the darkening proceed in the course of continuous printing, where bichloride and iodide only were used. The discrepancy of experience was sufficient, however, to throw doubt upon the value of the process, and excite lively apprehensions as to the ultimate fate of many valuable negatives already intensified by the method in question.

We are now able to announce a remedy for the evil—a means of restoring all such negatives which have become hard to their pristine softness and delicacy. We are indebted to Mr. Jabez Hughes for the information, the discovery having been made, accidentally we believe, in his

studio at Ryde, which enables him to obtain soft and detailed prints from valuable negatives which had been put aside, as giving hopelessly hard and unsatisfactory prints. The process of restoration simply consists in *roasting* the negative—holding it before a brisk fire until it becomes very hot. Whatever might be the precise cause of the evil, it appeared to result from a molecular change, the increased density did not arise from an aggregation of deposit, as in the usual processes of intensifying. The application of heat appears again to induce a molecular change, restoring the image to its original softness. We have not had opportunity of putting this experiment to the test ourselves, but have the assurance of a gentleman, vitally interested in the question, and accustomed to careful observation, that the remedy proposed is a valuable and trustworthy fact.

THE PHOTOGRAPHIC EXHIBITION.

SECOND NOTICE.

A MORE careful examination of the contribution at this year's exhibition, confirms all our first impressions, both as to general excellence and particular superiority. And we may add regarding the hanging, that we do not remember to have visited any exhibition in which a more pleasant effect was presented by the ensemble: there is a harmonious completeness in the general arrangement which satisfies the eye; the spotty scattered effect so common in such exhibitions, being fortunately avoided.

The first picture in the catalogue is an enlargement from a small negative by Mr. Ponting, of a beach scene. It is one of a similar class to several sent by Mr. Ponting to the International Exhibition. It is scarcely quite satisfactory, being wanting in force; it is nevertheless very meritorious for its pictorial effect, and is remarkable for its singular resemblance to a lithograph. Possessing many of the same beauties and faults are the contributions of Mr. Lyndon Smith. They are for the most part well chosen scenes—soft, detailed, and full of atmosphere—but they are so low in tone and wanting in power, that, being amongst more brilliant prints, they suffer by the comparison. His present contributions consist chiefly of Welsh scenery, and many of them are charmingly picturesque. The entrance to Llanberis Pass, (No. 13), is a very fine composition, and only wants vigour to be a fine picture. It is quite possible that, viewed alone, these pictures may be very good indeed. It is by juxtaposition with pictures possessing more contrast that they seem weak.

We next find a series of views of Osborne and other places in the Isle of Wight (Nos. 2 and 3). These are distinguished by clean bright photography, and in some instances very good composition; but there is perhaps, in some, a little hardness and want of atmosphere. The cabinet size, produced by the No. 1 triple lens which Mr. G. W. Wilson has rendered popular, is selected for these pictures, and is well suited to the class of views delineated. Very similar in character to the pictures of Mr. Rouch are those contributed by Lieut.-Col. the Honourable Dudley F. de Res (Nos. 14

and 74). These consist of various views at Windsor and Frogmore, and of the ruins of Grey Abbey, County Down. Some of these have a little tendency to hardness and want of atmosphere. A few clouds, or even a tinted sky, would have been a material improvement.

The bulk of the portraiture and figure photography is collected in one room distinct from the landscapes. For the purpose of varying the monotony, however, a few portraits and figures are hung amongst the landscapes, and in giving a detailed notice we shall proceed in consecutive order according to the catalogue, without reserving such portraits for a place in their own classification.

A couple of studies by Mr. H. P. Robinson, "The May Gatherer" (No. 5), and "The May Queen" (No. 6), are very charming. "The May Gatherer" is a pleasing rustic girl reclining on a grassy knoll, with a heap of hawthorn blossom. The position is graceful and natural, and the composition and photography both good, whilst the keeping of the sentiment is admirably preserved. "The May Queen" is a vignettted head of a sweetly simple and winning village girl, with a wreath of May blossoms entwined around her head. The photography is very good, the picture soft, round and beautifully modelled; but it is the charming expression, and wonderfully beautiful rendering of the eyes, which attracts attention most. We have seen a copy with the lines from Tennyson's "May Queen" appended, which the picture appeared admirably adapted to illustrate:

"There's many a black, black eye they say,
But none so bright as mine."

Altogether we might take this as a very satisfactory embodiment of "Little Alice."

The next subject-pictures which come under our attention are also executed in Leamington, and are by Bullock Brothers. The most striking and ambitious of these is the "Footsteps of Angels" (No. 20). In examining such a picture, the verdict given will much depend on the preconceived notions of the critic as to the legitimacy of the effort to make a picture by photographic means. Those who deride the attempt will chuckle over certain shortcomings here, as evidence of the inherent unfitness of the art to illustrate a poetical idea, or produce a picture with a story. We, who have always maintained the art-power of photography, and the legitimacy of every effort to develop its pictorial capabilities, examine such a picture with much interest, and regard its shortcomings with leniency. The picture fills nearly a whole sheet of paper, and the photography is decidedly good. The general effect as a picture, and the composition, are also good. The idea to be illustrated is that expressed in Longfellow's pretty little lyric, from which the title of the picture is borrowed, and which many of our readers may remember. The time is evening:—

"When the hours of day are numbered,
And the voices of the night
Wake the better soul that slumbered,
To a holy calm delight;

Then the forms of the departed
Enter at the open door;
The beloved, the pure hearted,
Come to visit me once more."

An elderly gentleman sits in an apartment lighted only by the fire; and, kneeling at his feet, is a female figure, intended, we presume, to represent the "Being beautiful," the departed love, referred to in the after lines. It is in this figure the chief failure is found; the choice of a model has been especially unfortunate, as the figure and face are not of that light, delicate, fragile, or refined type, which is suggestive of a disembodied state, and especially of the "messengers divine" referred to. As suggestion, not representation, is the only possibility in regard to such an idea, the selection of a suitable model was of vital importance, and especial care should have been taken to secure one with as little of material mould as possible. Again, the treatment of the figure is defective. There is nothing shadowy or indefinite here; the form is as essentially mundane and palpable as that of a figure still in the flesh. The pictorial

treatment of things unseen and immaterial must necessarily be more or less conventional, and all we can demand is that they shall in some way or other suggest the notion of disembodiment. It may be a dimly defined "shade," or a "luminous shadow," or it may be that uncertain substance of which Milton speaks—

"If substance might be called what shadow seemed,
For each seemed either ———"

But we want the idea suggested by the presentment in some way. This figure is very real, and an arm which is extended, unrelieved by any reflected light, is very black. Photography possesses resources for giving the air of immateriality we demand, and in such a case they should have been used. The effect of the firelight is very good, and for the most part the shadows in the deep gloom of the apartment are transparent and satisfactory. There are some lights for which we cannot quite account, regarding the fire as the sole source of light as the picture represents it. For instance, the bald head and the grey whiskers of the male figure are well lighted on the side opposite to the fire. On the whole the attempt is so bold, the result in some respects so good, and success missed rather by the want of a little more thought or effort than by the inherent difficulties in the way, that we have devoted more space to a consideration of its faults than we should have done if it had been a decided failure. And we intend these remarks rather as encouragement than censure. Two or three other large *genre* pictures, by the same artists, are less meritorious. A pair, "Mischief" and "Startled" (No. 47), do not express the ideas, and the models are ill chosen. "Confound the Screw" (No. 69), a musician tuning a violoncello, and perplexed by the difficulty of turning the peg or screw with one particular string, indulges in the expletive which gives the picture its title. Here the idea is well expressed, and the composition good; but the photography is a little coarse and hard.

The prints on resinized paper, from enlarged negatives, by Mr. Alfred Harman, will excite as much interest amongst photographers as any pictures in the exhibition, as they are decidedly the largest and best pictures of the kind which have been exhibited. The method of enlarging by two operations, first producing a transparency, and from that an enlarged negative, is one we have recommended for years. It has for some time been practised to a small extent. Mr. Samuel Fry has practised it for many years with great success. Mr. Vernon Heath and Warner have both, during the past year, given some popularity to the process by successfully applying and describing it. But none of the results that we have seen have been on such a large scale, and so entirely successful, as those of Mr. Harman. Here are four portraits, each about 22 inches by 17 inches, with accompanying prints from the card negatives from which the enlargement is effected. The portraits are chiefly standing figures, and some of them with various accessories; but in none, and in no part of them, do we find unsatisfactory pictorial definition, every part of each figure being as well defined as in the small prints, showing that no appreciable loss has been suffered in enlargement. No. 61 is especially fine, the composition being good, the image soft, round, vigorous, and well defined. The tone will probably be considered a little black by some, but the effect is very engraving-like, and will recommend the use of resinized paper—the sample used in this instance being, we understand, that prepared by Francis and Co., after the formula of Mr. Cooper. The print (No. 84) from an enlarged stereoscopic negative, printed on albumenized paper, scarcely strikes us as so delicate and pleasing as the others.

THE DISCOVERY OF THE METAL THALLIUM.

AMONGST the fruits already reaped from the valuable discovery of Messrs. Kerchoff and Bunsen, in reference to spectrum analysis, are, as our readers already know, three new alkaline metals—rubidium, cesium, and thallium. The

discovery of the latter of these, as our readers also know, is due to Mr. William Crookes, a gentleman to whom the photographic world generally is indebted for much information on the chemistry of photography. In the beginning of 1861, being engaged in spectrum examinations, Mr. Crookes discovered, in the flame of some residues of selenium, a single bright green line in a portion of the spectrum where such a line had not been seen before. Further investigations convinced him that this was a new element, which he shortly succeeded in isolating. The name of thallium was given to the new element—derived from a Greek word, signifying a young twig, the vivid green spectral line suggesting the name. The exact nature of the new body was not at first decided, but it was supposed to be a metalloid. In September of the same year, however, Mr. Crookes satisfied himself of its nature by obtaining the substance as a metal, which was shown to various persons in his laboratory.

Mr. Crookes seems destined to meet with injustice in regard to this discovery. In the International Exhibition, notwithstanding that he exhibited the metal and its compounds, and that his discovery of it was well known to the jurors, his name was not mentioned in the first published list of awards; whilst a French gentleman, M. Lamy, was rewarded with a medal for the discovery of new and abundant sources of the metal, the original discoverer of which was unnoticed. A proper and energetic exposure of this grievance brought some reparation. But recently Mr. Crookes has suffered another not less grievous injustice. M. Dumas, in a memoir just presented to the Academy of Sciences, denies to Mr. Crookes the discovery of thallium as a metal at all, and awards that honour to M. Lamy. The facts appear to us, however, to lie in a nut-shell. The credit is given to M. Lamy on assumed prior publication; and this publication of the metallic character of the new element is stated to have been made in a communication to the Société Impériale of Lille on the 15th of May, 1862. Now setting aside (as non-publication or insufficient publication) explanations and exhibitions to friends in the laboratory, here is the fact patent to all the world, that on the 1st of May, 1862, a case was exhibited by Mr. Crookes in the International Exhibition, containing samples of the metal and its compounds, in which it was distinctly labelled as a "new metallic element," and further described as a "heavy metal." Publication to a larger audience could not well have been made; and it is to be noted that the contributions of thallium to the International Exhibition by M. Lamy were not made until some time after it was opened. The comparison of the two dates appears to us to settle beyond a cavil the priority of the discovery; and whilst M. Lamy has had the good fortune and sagacity to discover abundant sources of the metal, it is clear that to an English investigator belongs the honour of discovering the element and deciding its metallic character.

PHOTOGRAPHIC CHEMICALS:

THEIR MANUFACTURE, ADULTERATION, AND ANALYSIS.

THE other compounds of alumina are of too slight importance to the photographic chemist to render any separate account of them of interest. The next element, the compounds of which demand our attention, is one which can scarcely be classed among the metals at all, although for the sake of convenience it is frequently so classified in chemical works. We allude to silicium, the oxide of which is the well known silica or rock crystal. In the natural state silica occurs under many forms; it is almost chemically pure under the form of fine white sand, immense quantities of which are brought from the Isle of Wight, for the purposes of glass-making. Another form of pure silica is known under the name of rock crystal. This is met with in hexagonal crystals, surmounted by hexagonal pyramids; the colourless transparent variety is largely used for optical purposes. Although not strictly coming under the category of a photographic

chemical, the properties of rock crystal are sufficiently interesting to our readers for us to devote a small space here to their description. Pure rock crystal possesses one great advantage over other solid transparent media, in being perfectly transparent to all the chemical rays of light. A photograph of the solar spectrum, taken with a complete quartz train—that is, with prisms and lenses of quartz—will show lines and bands in the spectrum three or four times as high as when taken with a glass train. In scientific researches upon the photographic action of light and colour, it is, therefore, necessary to employ rock crystal instead of glass wherever light has to be transmitted, as it has been shown by Mr. Crookes that the interposition of a piece of colourless glass, the hundredth of an inch thick, in the path of a beam of light, passing through a quartz train, is sufficient to cut off very considerable quantities of the chemically acting rays of light. By employing a meniscus lens of rock crystal for photographic purposes, very excellent results are obtained, owing to the large number of actinic rays which are transmitted by it on to the plate. A quartz lens can, however, be used only with a small aperture in front of it, as it cannot be achromatized without diminishing its transparency down to that of glass. Another objection to a quartz lens is its double refracting power, by reason of which the image formed by it is double when viewed under a high magnifying power. This defect may be obviated by taking care in the selection of the lens, or in having it cut in a particular direction, with respect to the axis of the crystal. When a beam of light passes through a crystal of quartz in such a way that it forms an angle with the axis of the crystal, it is doubly refracted, or split up into two rays slightly divergent. A lens cut from a crystal, in such a manner that the light would pass through, forming an angle with the axis, would therefore give a double image. When, however, a ray of light passes through a plate of quartz, parallel to the axis of the crystal, it is not doubly refracted; a lens, therefore, cut so that its axis coincides with the axis of the crystal, will only give one image.

It may be of use if we instruct our readers in a simple way of ascertaining whether a lens is made of quartz or glass. The latter is much the softer of the two, and therefore, by a comparison of one with the other, the sharp point of a file will show the difference without further trouble. This, however, is not a plan to be recommended, as it involves permanent injury to the lens. The plan we recommend is to employ polarized light for this purpose. A small tourmaline, which can be purchased mounted for a few shillings, is the only special apparatus required. A dark polished surface—such as French-polished mahogany, a japanned tray, black marble, or similar material—is placed on a table in front of a window. The photographer stations himself about four feet from this, so that the bright light from the sky is reflected upwards to him from the polished surface. The tourmaline is now brought up to the eye, and slowly rotated on its axis. As the crystal turns, the polished reflecting surface will be seen to become alternately light and dark; the tourmaline is kept in the position in which the reflecting surface appears darkest. The lens to be examined is now held between the tourmaline and the reflecting surface, and in its turn moved round on its axis. If the lens is of glass, no change will be produced by this movement; but if it is of rock crystal, it will become luminous during one part of its rotation, and then dark again, presenting a similar appearance to what took place when the tourmaline was turned round. It is possible, by this means, to ascertain in which direction, as regards the axis of the crystal, the lens is cut; and at the risk of not being clearly understood by some of our readers, we will endeavour to point out how this is discovered. Turn the tourmaline so that the reflecting surface appears quite dark, and move the lens on its axis until it appears luminous over its whole surface. Now turn the lens about sideways, so as to look through it in different directions diagonally, keeping the relative positions of top and bottom unchanged. As it is being moved about,

coloured spaces will appear on the luminous surface of the lens, which will pass over it in the order of the colours in the spectrum. On continuing to move the lens in the same direction as that which produced the colours, they will suddenly cease to appear, and will then be followed by another set of colours in the reverse order. The central position between these sets of colours is then to be returned to, and the experimenter will then be looking along the axis of the crystal from which the lens was cut. This may seem somewhat complicated and difficult to understand, but in reality it is very simple. After having once obtained the phenomena here described, any number of lenses can be tested one after the other, without spending more time than a few seconds for each. Anyone can obtain the appearances here noted by an attentive perusal of our description. Sometimes a quartz lens is found, in which the axis coincides almost perfectly with the axis of the lens, whilst at other times it will be found to be cut in such a manner that the two axes are almost at right angles to each other. Such a lens as this should, of course, be rejected.

We have already alluded to one property of rock crystal—its great hardness; this gives it an advantage over glass in cases where it is likely to be exposed to any rough usage, as it is very difficult to scratch. Another noticeable property is its power of conducting heat, being in this respect almost as good as a metal. A lens of rock crystal on this account is very quick in taking the temperature of the air in which it is placed, and in that respect possesses an advantage over glass.

Silica may be melted by exposure to a very high temperature. Before the oxyhydrogen blow-pipe, or in the flame of a spirit-lamp, fed with oxygen, it fuses to a clear bead. In the fused state it may be drawn out into long threads like glass. Fused silica dropped into water solidifies to a transparent mass, free from flaws, and remarkably hard and tough, so that it sustains the blow of a hammer without breaking, showing that it has become hardened, just as steel is hardened, by sudden cooling. It is very probable that this fused silica could be applied to many useful purposes if means were devised to prepare it in larger quantities. From its properties when fused before the oxyhydrogen blow-pipe, it is evident that, at a sufficiently high temperature, it could be worked like glass, and prepared in a variety of useful forms. To the chemist especially vessels of silica would be invaluable, as they would stand high temperatures as well as porcelain, whilst their power of conducting heat would doubtless prevent them from cracking so readily when exposed to sudden alterations of temperature. Another advantage of silica vessels would be that water and chemical solutions would have absolutely no action upon them, ordinary glass being very readily attacked by many chemical solutions.

PRINTING DIFFICULTIES.

BY A PHOTOGRAPHER'S ASSISTANT.

The time has arrived when with confidence I may venture to give publicity to the results of the experiments referred to in my last communication. Selecting for those experiments samples of highly albumenized paper, which, under ordinary treatment, yield a thickly studded crop of mealiness, I set to work systematically, determined to trace out the cause from whence originates the evil. Examining (with the aid of a powerful lens) the surface of a mealy print, produced on one of these papers, it at once occurred to me, that the irregularly mottled white spots, owed their existence to the removal of a portion of the slender film composed of reduced silver, which, previous to its exposure to the bleaching influence of the toning solution, had poured an unbroken coating over the entire surface of the paper. The thought suggested by this preliminary examination, at once enabled me to fathom the reasons, why highly albumenized surfaces, are at all times the most prone to the detested evil of mealiness. At this stage of the

enquiry I deemed it necessary to ascertain, as nearly as possible, the permeating power possessed by silver solutions of various degrees of strength, and to accomplish this I commenced with a bath containing 60 grains per ounce, then increasing its strength gradually with the removal of each piece of paper, I had, when finished, 6 pieces ready for exposure, whose surfaces contained silver in varied quantities, commencing with 60 grains, its minimum, up to 85 grains, its maximum, each having received the same amount of floating, viz.: 5 minutes.

The paper floated on the 60-grain bath when exposed to sunlight, yielded a print intensely red, the second that had been sensitized with a 70-grain solution, gave a tone slightly inclined to brown, the depth of this tone continued to increase with each remaining print, the shade varying in proportion to the strength of sensitizing medium. Cogitating upon the results thus produced, I at once arrived at the conclusion, that albumen in an undiluted condition, is capable of offering some considerable resistance to the efforts put forth by the nitrate of silver to unite itself with the chemically attractive chlorine, hence the reason why the first print was composed of little besides albuminate of silver, and that increased depth of tone was obtained from the graduated increase of silver, the additional strength enabling it to permeate the minute interstices of the film of albumen, and thus gain access to a more liberal supply of the chloride salts, and by a mixture of the violet hue, produced from the chloride of silver, with the red albuminate, the resulting colour assumed a purple or reddish brown—a colour, in fact, similar to a mixture of pigments—the above named tints when the proportion of red is the greatest. To convince myself that such was in reality the case, I went through the experiments a second time, giving the first paper half an hour's floating on the 60-grain bath, and the last, ten minutes exposure to the action of an 85-grain solution. When printed, the colour of each was as near alike as possible, viz. a reddish brown, but considerably deeper than was derived from the former trials; but still the red was in the ascendant, and an hour's floating on the strongest solution produced but little difference, which fact, to my mind, affords conclusive evidence that the silver penetrates a depth infinitesimally small when albumen undiluted is employed for coating to the surface of the paper. And here I would observe that paper albumenizers make a great mistake in the proportion of the chloride they mix with the albumen to be worked in its pure state. But more of this hereafter, as we have here to consider the conditions necessary to preserve the film of reduced silver uninjured during the toning operations. To do this, it is evident that gentle means must be adopted, or mealiness must assuredly follow; to effect this object I first pass the points carefully, but rapidly, through several waters, until all traces of liberated free nitrate ceases, they are then removed, a few at a time, into a flat porcelain dish, and thoroughly sponged (without this operation it is impossible to remove the whole of the free salt), after sponging and rinsing in a couple of additional waters, they are finally placed in a tepid bath, where they are left to soak half an hour, and then they undergo the toning operations: having ascertained the nature of the surface to be exposed to the toning solution, I, in my experiments, deemed it necessary to modify the bleaching power of the chlorine. An excess of soda would have accomplished this object, but at the expense of time and gold, I therefore had recourse to heat to produce a partial decomposition (thanks to Mr. Eliot for the idea). To the grain of gold I added $1\frac{1}{2}$ grain of carbonate of soda, which I find by experience is sufficient to start decomposing action, to this I added about half a pint of boiling water, then keeping the vessel near the fire for about ten minutes, carefully preventing the solution from reaching boiling point. This proceeding, with a continual agitating motion, tends to drive off the excess of chlorine, and the small portion of soda prevents the solution decomposing too far for toning purposes. This done the solution was laid aside to cool.

(To be continued.)

ON THE FORMATION OF THE PHOTOGRAPHIC IMAGE, &c.

BY M. OMMEGANCK.

THE constitution of the invisible photographic image has been the subject of numerous speculations and discussions, besides many important studies and researches, among which those of M. Testelin are of special interest. Without wishing to dispute the profound deductions of those who have devoted their attention to the investigation of this phenomenon, it may be permitted to me to offer some ideas, which, if not altogether novel, have certainly the advantage of solving the question in the simplest manner possible. It is indisputable, that wherever there is a modification of the material molecules, there is not only a change in the state of electrical equilibrium, but also a luminous and calorific modification; these three effects being like three chords of an instrument tuned in unison, one cannot be touched without putting the others in vibration. Nevertheless, we believe that a rational explanation of the phenomenon, under consideration, can be given by viewing the efficient causes from a more general point of view, instead of attributing them to an electrical influence, or to a kind of polarization produced by light.

The question is, What takes place at the moment the bromo-iodized collodion plate is exposed to the action of light? If the exposure be sufficient, the image is visible upon the plate in consequence of the decomposition of the salts of silver; the luminous vibration causes this decomposition, as heat reduces various salts of silver to the metallic state, and, to make use of a rough comparison, as the axe splits a log of wood. The luminous agent insinuates itself between the atoms of the iodine and the silver; but before the separation has become sufficient to disconnect them, there is a road to travel, a limit to pass, a dilatation to be produced, before the final rupture is effected.

There is also, what in chemistry is called, the "nascent state," being the peculiar condition of a body at the moment when it comes out of a combination, or forms a new one, a state in which it takes its natural course only after the lapse of a given time, and in which it subsists under a more dilated form. Is not a collodion plate, recently sensitized in the nitrate of silver bath, more impressionable at this moment than later, either when left in the bath or preserved in any other way? This is particularly appreciable in taking instantaneous pictures. We may, without difficulty, admit that the action of light brings the salts of silver to the extremest limits of the nascent state, before it effects their visible decomposition. If we pour the developing solution upon an exposed plate, the development, it seems to us, operates under the following conditions:—The developer, whether sulphate of iron or pyrogallic acid, decomposes the nitrate of silver with which it is mixed, this decomposition is moderated by the presence of a certain quantity of acetic or other acid. The decomposition would take place without the presence of a latent image. The molecules of nitrate of silver, before separating from their combination with oxygen and nitric acid, have a certain road to travel, and, consequently, a movement to perform; like an edifice about to tumble down, carries with it an arch about to give way, so does the decomposition of the nitrate cause the iodide to resume its natural state, and this last modification cannot take place without motion, accelerated locally and through a quasi-reciprocal action, by the successive decomposition of the nitrate. It is not the molecules of the nitrate already separated that we see floating in the developing solution, extracted from the nitrate and fixed upon a place, in quantities which go to form the image by an attraction more or less great in one place than in another: but the molecules of silver are proportionate to the light, more or less, which has acted upon the several portions of the plate.

(To be continued.)

ON PHOTOLITHOGRAPHY.

BY ANDREW MACTEAR.*

It affords me very great pleasure, indeed, to bring before your notice this evening, a system of photolithography as practised by Mr. Gibbons, in Glasgow, as far back as 1859, and to submit for your inspection some impressions by it, being the same which I showed to the old society a year ago, and which I am satisfied this meeting will pronounce to be genuine photolithographs, having all the appearance of the chalk-drawing mode. They are not shown as being perfect specimens, but as very creditable, and to show what might be done by its proper cultivation.

But before explaining Mr. Gibbons's mode, if you will allow me, I will give you a short history of the inventor and of the art of lithography itself, which gives employment to thousands, besides ranking as one of the most useful of the fine arts.

Germany, where type-printing was invented, and which has been the means of spreading the light of knowledge all over the world, also claims the invention of lithography.

Aloys Senefelder was born at Prague, in 1771, but soon after, he removed with his family to Munich. When he grew up he wished to be an actor, like his father, in Munich theatre; but his father was so much against it that he devoted himself to the study of jurisprudence, occasionally gratifying his histrionic appetite by performing in some of the smaller theatres, and employing his leisure hours in writing light dramas—one of which, he having been induced to publish it, realized him fifty florins clear profit.

At this time his father died, leaving a widow and family, and, being poor, he was unable to proceed with his academical studies.

The success of his first drama inspired him with such high hopes that he entered into theatricals, heart and soul, both as composer and performer, till, meeting with nothing but disappointment and misery for about two years, he gave up his profession as an actor to try his fortune as an author.

The next book he wrote turned out a failure, on account of the printer not having it ready for Leipzig fair; but it gave him occasion often to be in the printer's workshop, when an ardent desire possessed him to have a printing-press of his own, so that he could not only be author but likewise printer and publisher of his own works. He often afterwards said that, if his wish had then been gratified, he would never have been the inventor of lithography; but as this was not the case, he was obliged to have recourse to other projects. Amongst these was a sort of stereotyping—then etching with acids on different metals with various etching grounds, in which his knowledge of chemistry, gained at school, greatly assisted him. After trying a variety of etching grounds, viz., melted wax; turpentine and wax; turpentine, wax, and mastic, &c., with all their failures and disappointments, the one made with wax, soap, lac, and lampblack, which being soluble in water and easy to work with, was perfectly successful.

The repolishing of these metal plates, however, was so difficult and tiresome, that he was forced to give them up.

A slab of German stone, which he used for grinding his colours on, suggested the idea that it would not only be cheaper but easier to practise upon, a fine surface being both easily and quickly obtained, and they were so plentiful and cheap that they were commonly used for floors and pavements. He coated the surface of the stone with sulphuric acid, which formed gypsum, and then engraved his work, which he printed (same as with a metal plate) in the copperplate-press, but he never could get more than fifty impressions off, as the gypsum surface soon gave way, whereas, by his matured plan, and as now used, many thousands may be printed off by any careful printer.

* Read before the Glasgow Photographic Association, January 7th, 1863.

It was very fortunate that he found out the wax, soap, lac, and lampblack ground, as it opened up the way to chemical lithography. And now comes the interesting part.

A newly-polished stone was lying in his work-room, clean and ready to work upon, when his mother came in, and said to him:—"Aloys, please write down a list of the clothes for the washerwoman," who had then called, and was waiting for the "washing." He, having neither paper nor common ink at hand, wrote with his chemical ink on the clean stone, so that he might copy it at his leisure. Some time after this, just as he was going to wipe it off, the idea struck him—"What would be the effect of the writing, if I was to etch down the stone with acid, leaving the writing raised, and take impressions therefrom?" He at once set to work, and was fortunate in producing printed work from the stone for the first time; and thus was the new art invented. He now laboured hard to make himself master of this interesting art; but being unable to do so from want of means, he, for 200 florins, became substitute for a friend, as a private in the artillery of the Bavarian army, being confident that, with such means at his command, and devoting his leisure time to develop the art, he could soon be in a position to procure his discharge. But, alas! he was doomed to disappointment; for he no sooner arrived at Ingoldstadt with a party of recruits, than he was discovered to be a Bohemian, and, according to a recent order of the Elector of Bavaria, he was not allowed to join the army.

He left Ingoldstadt bordering on despair, and when he passed along the great bridge over the Danube he wished he had been drowned, instead of being twice saved from drowning when a boy, as misfortune persecuted him in every step he took.

He now resolved to serve as a printer; and he soon after produced some good specimens of music by his new art, which he showed to a publisher and to the court musician, and got an order for twelve songs—120 copies of each—which, being completed to their satisfaction, realised him a profit of seventy florins, when he thought himself as rich as Cræsus. A copy of this work having been shown to the Elector, he gave 100 florins as a present, to be divided between him and his publisher.

Being now possessed of means, he began to invent presses, one of which was a wooden frame on which was stretched a piece of strong cloth which he put on a table with hinges, the stone being fixed on the table, and charged with ink from a flat board covered with cloth (instead of the roller as now used); the paper was then put on, covered with a few sheets of damped paper, and the frame brought down like a tympan, when, after being well rubbed with polished wood or glass, the impression was made, and he was perfectly delighted at his success.

Again, however, disappointment attended nearly everything he did for about two years more, till, fortune being tired of annoying him, he, with an improved and most excellent press, and an order to print a prayer-book, made a brighter day dawn on the art.

As all was written backwards on the stone, he used to sketch it with a dark lead-pencil on paper, and reverse it on the stone by putting it through the press, when he was able to proceed to work with ease. Afterwards, instead of the dark pencil, he tried his chemical ink, and thus obtained a perfectly clear reverse. And now came the idea of using transfer paper with his chemical ink.

In the year 1796, after countless experiments, he was rewarded by the final attainment of his object; and money being now at his command, he matured the art, and produced work in every variety of style which is known and practised even at the present day, except photolithography.

In the year 1810, honour, money, gold medals, a pension from his Government, and an appointment as Inspector of Lithography, with a salary of 1500 florins a-year, permitted him to pass the remainder of his days in ease and comfort, when he not only painted some very creditable pictures, but

compiled his work on lithography, embodying all he knew with formulæ invaluable to his successors.

In issuing this work, he finished his introduction with these liberal words:—"God grant that it may soon spread all over the world; that it may prove useful to mankind, and contribute to their improvement; and that it may never be abused to any dishonourable or wicked purpose, and I shall then never cease to bless the hour in which I invented it."

In reading over the report of the first meeting of this session of the London Photographic Society in the *Journal of the Photographic Society*, when Mr. Osborne, from Anstralia, read a most interesting paper on photolithography—and which I think is the best mode for line work—it must have struck you, as it did myself, the rather unseemly way in which Mr. Poncey pounced on him, demanding an explanation of his mode of producing gradation of tint on the stone, and stating that nobody could do it like himself, which, nevertheless, he kept a profound secret. It reminds me of the little boy who, thinking himself very precocious, said to his father one day—"Papa, I can do what you canna do." "Aye," says the father, "and what's that?" "I can rin through between your legs, and you canna rin through between mine"—an idle boast, but comical withal. Mr. Osborne, in going through the subject, knocked the legs from Mr. Poncey by his "clearing-up" process, and proved M. Poitevin to be the real inventor of photolithography.

In working on the stone, either with the pen or hair pencil, a liquid ink is used, having a fatty substance as the principal ingredient; or if drawing with chalk on a grained stone, the chalk has also a fatty ingredient, which has been found to be the best medium to resist the wear and tear of printing thousands of impressions; and by transfers, with re-transfer ink, you may go on *ad infinitum*. The system of photolithography, therefore, approaching the nearest to this in principle will, I think, be found the simplest and best; and Mr. Gibbons's plan coming about the nearest to it, will be probably the soonest brought to perfection, if diligently practised, as it should be, when he freely gives it to the public at large, knowing that it is only "practice that makes perfection," and that it is impossible for him, alone situated as he is, to give it the attention it deserves, and that he would only be keeping back his portion of what is yet destined to play an important part in the art-world.

I will now submit Mr. Gibbons's system of photolithographing gradation of tints:—

1. Grain a lithographic stone with fine sand or emery-flour, taking care to avoid scratches; wash it well, and thoroughly dry it before using.

2.

SENSITIVE SOLUTION.

Copal varnish	1½ ounce
Raw linseed oil	½ "
Bi-chromate of potash	2½ ounces

Grind these three very finely, and put into a bottle; then add

Brunswick black	1 ounce
Mastic varnish	½ "
Turpentine	1 "

Put these three also into the bottle, and mix well together.

3. Coat the stone carefully with the above solution, by pouring a little on the stone, and roll over with a clean lithographic roller till it has evenly and thinly spread over its whole surface, which dries in a short time.

4. The glass negative is placed collodion side next the stone, and is kept from shifting by being stuck down by gummed paper round the edges. Exposure—from one to five hours, according to strength of light.

5. After exposure, remove the negative, and with a tuft of fine cotton-wool, soaked in linseed oil, rub gently over the stone, when the parts of the picture not acted on by the light will gradually come away, leaving the graduated tints quite firm. The proofs now shown were produced by this process.

6. The oil is now cleaned off the stone to prepare it for etching, which is done as follows:—Take a tall jug, nearly full of clean water, and place it in the hydrometer No. 1, when it will float at 0; then add dissolved gum-arabic, mixing it well till it floats at 6; then add nitric acid, mixing it intimately till it floats at 7, which is the strength found best for etching.

ANOTHER MANNER.

After the stone has been prepared as before, after exposure, it may be placed in a bath of turpentine or naphtha, keeping the stone in motion till the picture is developed.

ANOTHER,

By which very good pictures have been got.			
Brunswick black	1 ounce
Copal varnish	1½ "
Mastic "	1 "
Turpentine...	1 "

This is very much slower, the bi-chromate of potash being a very great accelerator.

7. With shoemakers' resin—or common pipeclay will do—make an embankment round the edges of the stone about one inch high (to prevent the solution running over the sides while etching); pour on the etching solution, and let it remain ten to fifteen minutes; wash off and charge with ink in the usual way, when the printing may be proceeded with. Care, however, must be taken that the stone is quite cold before doing so.

Mr. Gibbons has printed as many as between 2000 and 3000 from the one single positive, which completed a business order, and as many more could easily have been done, as the condition of the stone was perfectly good. He has always been fortunate, having scarcely ever failed while working in the country.

It is very interesting to examine the various steps by which photolithography has attained to its present position, which I will just glance at.

1. M. Nièpee, long before Talbot or Daguerre found out their processes, discovered the action of light on bitumen, and by it etched on steel plates. Then Nièpee de St. Victor used bitumen dissolved in essential oil of lavender, also for metal plates; and shortly after Mr. Macpherson, of Rome, adapts the same substance to the lithographic stone, and takes out a patent for photolithography by the "bitumen" mode.

2. In 1838-9, Mr. Mungo Ponton, of Edinburgh, observed and pointed out the peculiar action of light on bi-chromate of potash, which made it insoluble.

1853. Afterwards Talbot finds that it is the organic matter which is in combination with the bi-chromate of potash which becomes insoluble, and invents engravings by that process. Pretsch works on a similar idea, but makes a matrix from which he electrotypes his plates.

1855. Poitevin is the first to use the bi-chromate of potash for the lithographic stone.

1859. Asser, of Amsterdam, invents the transfer process. It may be remarked here that Sutton noticed that printers' ink, put on gelatine paper, would come away if soaked in water, leaving the paper quite clean.

Then Colonel Sir Henry James and his assistants improved upon Asser's mode, by passing through the press, on a stone charged with re-transfer ink, the exposed paper, instead of passing the ink roller over the wet paper, after the parts unaffected by the light have been washed away. Mr. Osborne hit upon a plan almost identical with Colonel James's simultaneously, being, at the same time, unaware of Asser's plan.

There are others deserving of great praise—Mr. Pouncy among the rest—for their ingenuity; but the names mentioned stand out in bold relief in connection with the different modes.

I may state here that the great retarding influence to photolithography is the dread of coming into collision with

"patent" rights; and I think it is a great pity to see such a grasping disposition shown by those who patent the various modes, especially as they are themselves so much indebted to those genuine liberal-minded men, who felt it a pleasure to give to the photographic world any knowledge they themselves possessed.

I may state that I became an experimenter after seeing Macpherson's pictures, which were exhibited in Glasgow at the meeting of the British Association, in 1856; but being afraid of patent rights, I gave it up, as the safest way of steering clear of those who intimated that proceedings would be commenced against any infringement.

It is now pretty generally believed that no patent is valid in this country. Should such be the case, and the various journals would give publicity to the fact, a great start and impetus would be given to it; and by all working diligently it would very soon occupy a very important place in the fine arts.

THE APPLICATION OF PHOTOGRAPHY TO THE MAGIC LANTERN EDUCATIONALLY CONSIDERED.

BY SAMUEL HIGHLEY, F.G.S., F.C.S., &c.*

It may seem strange (to some presumptuous) that anyone should wish a body like this Society to give an evening's consideration to that reminiscence of the nursery, the Galanty Show, to that toy of our boyhood, the Magic Lantern. Many scientific phenomena, when first discovered, either from their remarkability or beauty, have excited much interest in the popular mind, but have only been regarded by it as pleasing toys, till in the course of time their practical value has been discovered, and they have been ranked thereafter in the list of applied sciences.

Such was the globe of water, magnifying in distorted form the fly or flower, till in the hands of science it sprang into that exquisite refinement of optical knowledge, "the Microscope," that discoverer of hidden worlds and life, and the seat or form of disease within the inmost walls of the human frame. Such the Kaleidoscope, the tin case with its bits of coloured glass, regarded long only as a wonder from the fair, till in practical hands we find ourselves indebted to its aid for many of the beautiful geometric designs which ornament our walls or floors.

So, likewise, the Camera-obscura, the discovery of Baptista Porta, of Padua, till the progress of chemical knowledge revealed to us the means of fixing its fleeting images; and even then its products, together with its adjunct, the stereoscope, were little thought of in their most valuable practical bearings. Of late, however, this has rapidly impressed itself upon us, though we cannot as yet even see the limits of its educational utility.

In Microscopy, Natural History, Physiological, and Pathological research, what an invaluable agent does photography prove; for nature here depicts herself with her own pencil, and, possibly, ere long from her own palette, and in this resides one of its greatest values, for truthfulness is insured, and our studies are delineated with a faithful and unbiased hand; with what minuteness of detail the photographs I shall exhibit will bear witness.

I trust that I shall be able to prove this evening, to many who may not previously have given attention to the subject, that the magic lantern is likewise, with attention, destined to become an instrument of great educational value. We are most of us aware that natural history designs have been produced by the ordinary magic lantern colourist, and many such subjects, even when produced with care, have made us exclaim with Polonius that the representations have been—"very like a whale." Undoubtedly many subjects painted for the lantern are really artistic productions; but can the best artist for one moment pretend to cope with Dame Nature in her artistic moods? Can any artist (even if he be a pre-Raphaelite) for one moment hope to introduce the amount of detail she, with her undulating brushes of light, fixes upon the film, which her assistant the chemist, has prepared for her? For it must be borne in mind, that while the artist delights in broad effects, the naturalist regards detail

* Read before the London Photographic Society, January 6th, 1863.

as a *sine qua non*, their aims being different; and it must be patent to every one, that while the painted views we have long been accustomed to, meet every requirement, where mere amusement is concerned, photographic transparencies on glass will be the great means by which the magic lantern will be rendered subservient to the purposes of instruction.

Although many persons in private have employed photographs for the magic lantern, I believe that to Messrs. Negretti and Zambra the honour is due of having first produced for public sale subjects of geographical and artistic interest, specially prepared for the lantern; but I am not aware that any one besides myself has entered upon this branch of trade with special educational aims. I have long been impressed with the conviction that the lecturer on Botany, Zoology, Microscopy, Geology, Astronomy, and even on Pathology, would welcome as a boon truthful transcripts of nature that could be packed in a small space, and then shown on a scale to arrest attention in the student. This idea is actuated by no showman's feeling; for all persons who have had any experience in scientific educational matters know the value of appealing to the eye. Book knowledge, or that experience, gained even from the most graphic description, is of little value to the student who would become a true naturalist. He must see—if possible, handle—the objects of his study. The next best thing to this is to be familiar with the most accurate delineations of the forms he wishes to become acquainted with; and here photography offers her aid, and the magic lantern popularises her efforts.

But the naturalist is not the only favoured teacher; the art-professor may likewise avail himself of these aids to education, and so may the teacher of literature. In high-pressure steam days, like the present, the student has enough to do to make himself familiar with all that he is expected to be acquainted with; and if he really meets all the requirements of the Board of Education examiners, he ought to rank as the eighth wonder of the world. But, by the aid of Photography and the magic lantern (would that some more scientific, if not so familiar, a name for our instrument were recognised), teachers could kill two birds with one stone; for, while they were familiarising their pupils with the peculiarities of style of eminent artists, they might simultaneously convey to them the leading features in the works of celebrated authors such artists had illustrated. Thus I shall presently show on the screen how Kaulbach's wonderful style and Goethe's bitter satire may be illustrated by the photographic illustrations to "Reynard the Fox." Again, how Hogarth and morality may be combined, in the counterparts of the celebrated engravings of the "Good and Idle Apprentices;" and how the great stories of the Bible may be illustrated simultaneously with dissertations on the bold and vigorous designs of Schnorr. I will also show how the singing-master may avail himself our method, so as to place the words and music of a hymn, or other appropriate song, before a choir, when such subjects as Schnorr's Bible pictures are being exhibited in the dark.

And now to the means by which we accomplish our purpose. In the first place, the negatives may be those of the usual character; but, if taken expressly for the lantern, it should be borne in mind that the pictures should be included within circles. Whenever it is possible the negatives should be taken from nature, animate or inanimate; but there are many cases where this is impossible, and when a diagrammatic treatment of the subject is desirable. This specially holds good with many oceanic forms of life; for, when out of a sufficient bulk of their native element, they collapse, and look anything but "from the life."

Again, from the rarity of the subject desired, it may be necessary to resort to engravings; but no expense should be spared to procure them from the works of the best authorities, and in such a style of execution as is to be found in the works of Ray and Paleontographical Societies. If artistic, the negatives should always be taken from the originals, so that the characteristic touch of the artist may be ensured. Where negatives of microscopic objects have to be secured, we must adopt one of several arrangements that are founded on a common principle.

Negatives of microscopic objects may be produced by the method originally proposed by the late Mr. Joseph Delves, which simply consists of placing an ordinary microscope (from which the eye-piece has been removed) in connection with a solid or bellows-bodied camera, having a focussing range of from two to four feet, or a solar microscope arrangement,

fitted to the window of a darkened room, the room itself being used as a camera, as preferred by Mr. Wenham, or my own arrangement, which conduces to compactness of parts, and the optical portions being always in adjustment when required for use; or the arrangement of Dr. Maddox, who replaces the reflecting mirror with an Abraham's achromatised rectangular prism, and employs a Coddington lens for the condenser; or the arrangement of the Rev. W. T. Kingsley, who employs a very complex system of condensers, an achromatic eye-piece of peculiar form, the oxyhydrogen light, and determines the position of the chemical focus by means of a fluorescent screen. If low powers are to be employed, a microscopic plane mirror collects the light, and reflects it through the object-glass on to the sensitized collodion film, as shown in fig. 1. If, however, the higher powers are to

Fig. 1.

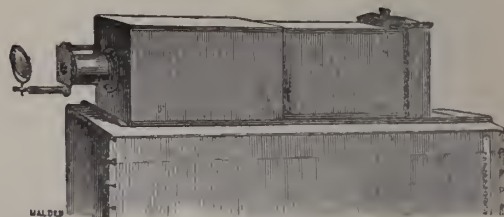

be used, it is sometimes preferable to collect the sun's rays by a long plane mirror, mounted with a rackwork rotating support, and adjusting screws, so that it can be made to follow the sun's course, and the light so collected is condensed on to the object either as parallel or convergent rays; in the latter instance by means of achromatic lenses having the same angular aperture as the microscopic object-glass in use, as in fig. 2. As, however, all microscopic object-glasses are "over

Fig. 2.

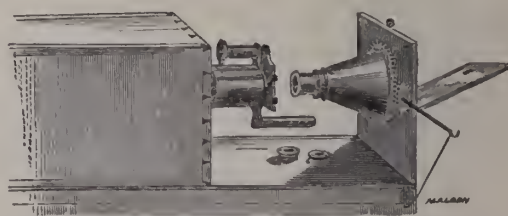

corrected," it is necessary to adopt some method for bringing the chemical image into focus on the film, after the visual focus has been determined on the greyed glass screen, and this is effected by aid of a micrometer head working on a screw attached to the stage (the parts being "kept up to their work" by means of a strong spring), the difference between the chemical and visual foci being determined experimentally for each object-glass for a given distance between the object and film; or, if great precision is desirable, special correction must be made for every object, for Dr. Maddox has found that the medium in which the object is mounted, its thickness, and the thickness of the cover, all have to be allowed for in securing perfection in the negative.

While, however, a considerable difference exists between the position of the chemical and visual foci in object glasses of low power, with the higher powers the difference is practically *nil*.

The great art in producing negatives of microscopic objects in the utmost perfection depends upon skill in the manipulation of the illuminating appliances, and I do not think anything has yet surpassed the photograph of *Navicula angulata*, produced in 1853 by the late Mr. Joseph Delves, a specimen of which (though, unfortunately, a faded one), is on the table. Negatives of microscopic objects may be produced by artificial sources of light, as the electric, oxy-hydrogen, camphine, naphthalised gas, or photogenic pyrotechnic mixtures, as recommended by Wenham, and employed on a large scale by Moule.

(To be continued.)

The International Exhibition.

REPORT OF THE JURY ON PHOTOGRAPHY AND PHOTOGRAPHIC APPARATUS.*

CARBON PROCESSES, PHOTOLITHOGRAPHY, PHOTOZINCOGRAPHY, &c.

In 1852 Mr. Fox Talbot patented the use of bichromate of potash and gelatine in connection with a process of photo-engraving. In 1855 M. Poitevin deposited, at the office of the Prefect of the Seine, a description of a process in which bichromate of potash and gelatine were combined with colouring matter for the production of photographic impressions. Since then a variety of processes, all of which have been modifications of the same idea, have been proposed and tried with greater or less success, and by means of some of which very beautiful results have been obtained.

It is needless to refer at length to the various other methods that have been proposed of producing permanent photographic impressions. The salts of iron, the salts of uranium, and other materials have been tried, but without that amount of success which would lead to their popular adoption. At the present time the salts of silver form the basis of all photographic processes commonly available; but the results obtained by some of the various carbon processes are such as to justify a hope that they may ere long take an established position in the production of photographic prints, and thus obtain a degree of permanency equal to that secured by any other method of pictorial representation.

Photo-engraving and Photolithography.—Amongst the most important methods of multiplying photographic impressions, are those in which an etched or engraved plate, or an impression upon the lithographic stone, are printed at the ordinary copperplate, typographic, or lithographic press.

The importance of these methods, as a question of economy, cannot be over-estimated; already a high degree of excellence is obtained, and there is every reason to hope for further improvements. In October, 1852, Mr. Fox Talbot patented a process for engraving photographic impressions on steel plates. This process is similar in principle to many which have followed. It consists in coating the steel plate with a preparation of bichromate of potash and gelatine; and the action of light upon this compound is to render it insoluble. A transparent positive picture being placed upon such a surface, the image is produced in insoluble gelatine, whilst the protected parts, consisting of the shadows, continue soluble in water; the plate after exposure, being washed, the soluble parts are removed, the insoluble remaining. The plate is then submitted to the action of an etching fluid, consisting of a solution of bichloride of platinum, which fills in the shadows, leaving the lights untouched. Mr. Talbot has, since his first publication, made many improvements in the process, the chief of which is a method of obtaining half tones by communicating to the plate a grain or aquatint ground, which is effected by dusting the plates with a coating of powdered resin previous to etching, and which is now done by perchloride of iron.

It will be seen that the principle upon which this process is based is capable of extensive application and modification: by a slight variation of the earlier details it is possible to obtain, not an engraved plate, but a mould or matrix, from which an image in relief can be produced capable of being printed at the ordinary typographic press. Considerable progress has been made both in this direction, and in photographic intaglio engraving, by Mr. Paul Presteh, who, by the judicious combination of photo-engraving and the electrolyte, has produced some results which are full of promise.

Other methods of engraving have been also suggested, one of which is based upon the principle by which the first permanent photographic impressions were ever obtained. The action of light renders insoluble certain bitumens. A plate of copper or steel, coated with such a substance, and exposed to light under a photographic image, is capable, after the parts not acted on have been dissolved away, of being etched by any corrosive fluid in the usual way. Other processes have been tried, but none have been hitherto brought to a higher state of perfection than that the principle of which has been described, and which, in the skilful and persevering hands of Mr. Paul Presteh, affords considerable promise that it may ere long be successfully used for book illustrations and similar purposes, with very slight aid from the engraver. The results are already very good, and in the reproduction of lines and points in any subject where the effect is not obtained by gradation of tints, the untouched image leaves very little to desire.

Not less important, and perhaps still more advanced to perfection, are the processes of photolithography, † and photozincography. The principle upon which the processes is based is analogous to that just referred to, but is entirely different in detail, and is so full of interest that a brief sketch of the operations is desirable.

In photozincography, Col. Sir Henry James proceeds thus:—A sheet of engraver's tracing paper is washed with a solution of bichromate of potash and gum, and exposed under a negative collodion to light; it is then passed through the press on a zinc plate charged with lithographic ink, the paper being perfectly and evenly covered. It is then turned over on a plate of glass, the back moistened with gum and water, which, passing through the paper, dissolves the gum and soluble portion of bichromate of potash to which the ink adheres, whilst the insoluble portion on which the lines and letters are unaffected. The hold of the ink to the blank part of the drawing having thus been destroyed, the paper is again passed through the press on a plate of zinc charged with ink. The second coat of ink brings away with it all that was on the blank parts, at the same time leaving a second charge of ink on the lines or letters. Some skill is requisite in all these operations. The transfer to zinc is made by the anastatic process, and so perfectly are the letters and lines charged with ink, that even four plates can sometimes be produced from one and the same photograph.

Mr. Osborne's plan is this:—A sheet of paper is prepared with albumen and passed through the press upon a polished plate of metal, then coated with a solution of bichromate of potash and gelatine, and again passed through the press. It is now exposed to the light, covered with the negative it is desired to copy; the paper is then passed through the press, face downwards, upon an inked lithographic stone, which gives the whole paper an even coat of ink, and the back of the paper is then placed upon boiling water, which coagulates the albumen; a subsequent short soaking swells the unaltered gelatine, and with it raises the corresponding ink from the surface, which a slight friction with a sponge removes. When the lines appear well defined, boiling water removes the last traces of the gelatine, and the print is dried. A lithographic drawing in greasy ink remains, which is transferred to the stone in the ordinary passage under the press. For the invention of this process, which Mr. Osborne has patented in Australia, the Government of the colony of Victoria awarded him £1,000.

Another process of photolithography now in use in the Imperial Printing Office, at Vienna, and used with much success, consists in taking a properly prepared collodion negative coated with gutta-percha, and removed from the glass in the way which was patented by Mr. Archer, in August, 1855. The polished surface of the stone is coated with one part of powdered asphaltum dissolved in thirty parts of chloroform; when dry, the negative is placed upon it and exposed for three hours in the sun, taking especial care that close contact is preserved; the negative is removed, and oil of turpentine, and, at the same time, water are quickly poured upon the stone; when dry it is ready to be handed to the lithographic printer, who first gums it in and then applies ink by the roller as if he intended to take impressions. When the stone is perfectly inked it is to be slightly etched, and again gummied, which completes the operation.

A variety of other modes have been proposed and practised with various degrees of success; but the most satisfactory processes are those described: although the production of half-tones yet remains to be accomplished, so far as the reproduction of lines is concerned, little now remains to be obtained. The saving effected to the country in Ordnance maps alone amounts to many thousands per annum. As another illustration of the economic value of photolithography, it may be mentioned that one of the Australian maps reproduced by Mr. Osborne, which formerly sold at two guineas a copy, has been reduced in price to three shillings. As a means of indisputably accurate reproduction of any document, either the same size, or on reduced or enlarged scale, it is impossible to overstate the value of the processes; for the copying of scarce and valuable literary works it is of the utmost importance: it has already been applied successfully to several such purposes.

DRY PROCESSES.

Leaving the methods of printing, or multiplying photographic impressions, and briefly recording the production of negatives, it is important to glance at what are termed the dry processes.

The wet collodion process having already superseded to a large extent all other methods, it soon began to be apparent that the necessity of taking into the field a dark tent, or portable laboratory, involved an amount of labour incompatible with the convenience of the amateur photographer. Attention was turned to the possibility of preparing the plate at home, and preserving the sensitiveness for use abroad.

The use of the dry albumen of Niepce de St. Victor did not become popular for a variety of reasons.

On the first introduction of collodion, in 1851, Mr. Archer, Dr. Diamond, and others had used the collodion plate, simply washed and dried, with some degree of advantage, but they were not enabled to secure satisfactory results. Messrs. Spiller and Crookes, in 1854, suggested the application, to the sensitive surface, of a solution of the nitrates of zinc, magnesia, &c., by which means it could be preserved for some time without injury, and kept ready for exposure.

The idea of using a neutral hygroscopic preparation for preserving intact the sensitive condition of the film, being once suggested, various other plans followed, and the use of glycerine, oxymel, and syrups of various kinds was proposed, each process, more or less satisfactory in the hands of those who advocated them. Mr. Shadholst and Mr. Maxwell Lyte, previous to Messrs. Spiller and Crookes's experiments, had used honey with much satisfaction in the results. These methods, as preservative processes, were attended by several inconveniences arising from the moisture of the preserved surface.

The process by which some of the best results have been produced, and which has grown, rather than declined, in popularity as time has advanced, is that known as the collodio-albumen process of Dr. Taupenot, which was published as early as September, 1855. This is an absolutely dry, and not merely a preservative process; it consists in applying to the excited and washed collodion film a coating of iodized albumen; this is then submitted to the action of a bath of aceto-nitrate of silver, washed, and dried. The plate is now ready for use; its chief drawback has arisen from its want of sensitiveness. Various modifications of recent date have, to some extent, removed this drawback: the process is practised with great success by some of the ablest devotees of the art.

The use of gelatine, metagelatin, malt, gum, and of a variety of other materials have also been proposed, and many of these substances, as coatings to the sensitive collodion film, are used by their promoters with success.

In 1853, Mr. Fothergill published, in the *Times*, a process based upon that of Taupenot, by which, not only were the manipulations much simplified, but additional sensitiveness was obtained. It consisted in applying to the excited and washed collodion film a coating of dilute albumen, which, having been allowed to remain a short time and permeate the pores of the collodion,

* Continued from p. 34.

† The following may be considered as a classification of photolithographic processes:—

On stone direct, using asphaltum as the sensitive surface on the stone—	
2. M.M. Lemercier, Lerebours, Barreswill, and Davanne, Paris	1853
3. Mr. Macpherson, Rome	1855
7. Printing Office, Vienna	1859
M. Nègre, Paris	—
On stone direct, using gelatinous substances with bichromate of potash on the stone—	
4. M. Poitevin, Paris	1855
6. Mr. Cutting, Boston, U. S.	1858
On Photographic "transfer paper," using gelatinous substances and gum with bichromate of potash on the paper—	
8. M. Asser, Amsterdam, gum and blotting-paper	1859
9. Mr. Osborne, Melbourne, who used gelatine and albumen	1859
10. Col. Sir Henry James, Southampton (Ordnance Survey)	1860
Other processes—	
1. M. Jobard, on stone and zinc direct, with the help of iodine, Brussels	—
11. Mr. Austen A. Turner, Boston	1860
5. M.M. Roussau and Masson, France, on stone direct with gelatine and bichromate of ammonia, &c.	1856
Dr. H. Hallcur, Bochum, on stone direct; two processes, one with oxalate of iron, the other with asphaltum	1854

was washed off, and the plate dried and kept ready for use. This process continues to be successfully practised by many photographers, especially for small plates.

Without referring to the many modifications from time to time proposed, the next important is the tannin process, discovered by Major Russell, which promises to be one of the most useful, simple, and popular methods of using dry collodion. It consists in the application of a solution of tannic acid to the sensitive film of collodion, which has been well washed, to remove any free nitrate of silver. The plate, when dried, is ready for use, and may be kept a very considerable time without deterioration. The simplicity of the operations, and the beauty of the results, are high recommendations to the adoption of this process. Some modifications have also been proposed with a view of increasing the sensitiveness of these plates, and from which, probably, more rapid results will be obtained. Dry collodion has, also, again been lately used with considerable success, simply by the addition of various resinous substances to the collodion employed.

The great desideratum, which, in dry processes, yet remains to be satisfactorily supplied, is an amount of sensitiveness equal to that of wet collodion. The use of hot development has been found an important auxiliary in this respect, which, with some other methods recently proposed, are now on their trial, and give great hope of success; but, with the exception of certain plates prepared by Dr Hill Norris by a secret process, the results of dry collodion continue inferior in sensitiveness to those of recent collodion.

(To be continued.)

Correspondence.

FOREIGN SCIENCE.

[FROM OUR SPECIAL CORRESPONDENT.]

Paris, 21st January, 1863.

M. OMMEGANCK confirms M. l'Abbé Laborde's recommendation, on the score of economy and better results, of the introduction of a certain quantity of alcohol into the silver baths for paper positives. He employs the following solution:—

Alcohol	33 parts
Nitrate of silver	8 to 10	„

The result, he states, has greatly exceeded his expectations, as well as that of certain friends who have made the experiment. The paper is allowed to remain two or three minutes on the bath; it dries very quickly, prints more rapidly, the tones are infinitely superior, and are obtained with great facility.*

A series of clear fine days has caused our photographers to raise up from their winter apathy, and put their houses in order for the coming spring campaign. Public taste seems pretty equally divided between the miniature *carte de visite* portrait and the life size; photographers, however, do not appear at all ambitious to cultivate the latter phase of portraiture, so many difficulties attend its successful and profitable practice; and, as before, doubtless the *carte* will be the principal branch of the art carried on during the coming season.

There is not much left to say upon the miniature photographic portrait. With respect, however, to the *life size*, it may be remarked that herein lies a fine field for the artist's skill and taste, and, it may be added, profit also. A successful life-size photograph, enlarged from an instantaneous microscopic negative, possesses qualities which cannot fail to command the attention both of artists and the public. Those who are very exacting in demanding that a photographic portrait be truly correct as a likeness, insist that only instantaneous pictures can possibly fulfil that condition. The life-size portrait, when produced upon chloride of silver paper, owing to the length of the operation, requires the aid of a heliostat—a piece of apparatus necessarily costly, from its clock-work movement. Paper prepared with iodide of silver enables the operator to dispense with the heliostat; but perhaps the best medium of all for taking life-size portraits on, will be found in collodion on paper. The pictures are remarkably delicate in detail, of very fine tones, and unquestionably durable. A portrait life size may be obtained, even in dull weather, in five minutes, and with the simplest apparatus.

Those who prefer employing paper prepared with iodide of potassium for negatives, obtain it by imbuing the paper first with an alkaline iodide, and then floating it on a

nitrate of silver solution, or by reversing this order of preparation. This method may be modified by moistening the paper with a liquid holding iodide of silver in solution. We know of two solutions of this kind which, probably, might be advantageously employed on account of their sensitiveness. Both iodide of potassium and cyanide of potassium freely dissolve iodide of silver, forming a colourless liquid insensible to light, both of which, upon contact with nitrate of silver in excess, precipitate the iodide of silver dissolved, forming in the first instance a new portion of iodide of silver corresponding to the iodide of potassium in excess, and in the second instance cyanide of silver corresponding to the cyanide of potassium in excess. In these reactions the iodide of silver is precipitated under peculiar conditions, from whence results a much greater sensitiveness.

Photographers have a great prejudice against the access of iodide and cyanide of potassium during their operations; this prejudice is justified by the property these salts possess of paralysing the action of light wherever they exist in excess; but when the salt of silver predominates, all the conditions are changed, and there results only a formation of nitrate of potassa.

We do not know much about the sensitiveness of cyanide of silver to the action of light, and still less about that of the cyanide associated with iodide of silver in the nascent state. If the paper prepared according to the last process shows a great sensitiveness, we can perhaps apply this process to collodion, by adding to the iodide a minute quantity of cyanide of potassium, which, when pure, dissolves very readily.

In employing cyanide of potassium with paper or collodion, we may perhaps be obliged to fix with cyanide of potassium, if hyposulphite of soda be insufficient. This would be inconvenient and objectionable, because the cyanide rapidly dissolves the more delicate portions of the negatives; but if its sensitiveness be proved, it will be easy to find a less objectionable fixing agent.

We can also prepare sensitive papers, for enlarged portraits, by floating them on a nitrate of silver solution to which a small portion of gelatine has been added, thereby increasing the effect of the sizing.

To develop the picture, we must employ, instead of the acid sulphate of iron (which yields only grey tones of metallic silver), gallic or pyrogallie acid, with a small proportion of tannin, to fix the gelatine. We shall in this obtain very fine tones; and this silver bath, applied to a paper imbued with an extremely dilute solution of iodide of silver dissolved in iodide of potassium, will certainly combine all the conditions of a great sensitiveness, especially when in the moist state; leaving it, however, to dry partly, before developing, to prevent the gelatine from detaching itself, which it does, notwithstanding the tendency of the tannin and the reducing acids to fix the product.

From the infinitely small quantity of iodide of silver thus employed, these proofs might almost be fixed by simply washing them in water. They never fade, and if their hue be too red, they may be toned in the usual way by chloride of gold.

The great perfection of the mechanical and chemical elements of photography to which we have attained, and which every one desirous of practising the art can so readily acquire, leads to the conviction that the differences we now observe in the portraits taken by various operators are due to the good or ill lighting of the operating-room. The prevailing error I observe to be too much light, by which a flat, insipid picture results. In the supposed necessity for having an entire glass house to operate in, there is involved a great difficulty, and constant annoyance, in seeking to regulate the light, or get rid of the excess. There is plenty of room for the exercise of a little common sense in this direction, which would also lead to a great saving of expense in fitting up the studio.

* See letter on p. 30 on this subject.

THE PATENT ALBUMENIZED PAPER,

MY DEAR SIMPSON.—Your correspondent, Mr. Angelo Bianchi, writes as if it were a very easy matter to prepare my patent albumenized paper with the rubber solution, and he alludes vaguely to several persons who have employed this process.

To me it has had many difficulties, and the novelty of my patent consists in the mode of overcoming these practical difficulties, in great measure. All these novelties will be fully explained in my complete specification, if I complete my patent in the spring. In that case, your readers will know how I manage to succeed. But if all these things have been published before, and are generally known, there will be no necessity for me to tell people anything about them, and they can prepare their paper by M. Gaumé's, or anybody else's published formula, if they please, while I use my own process. If I am badgered about this patent, that is exactly what I shall do. My secret has not yet leaked out, and if I have to deal with many such gentlemen as Signor Bianchi it never will.

I send you a sheet of my rubber paper in which the albumen has entirely sunk in instead of lying upon the surface. You see there are many queer things which do not exactly lie upon the surface. Permit me to take this opportunity of publicly thanking you for the very kind manner in which you have reviewed my new work on the Collodion Process. I only wish it deserved half the good things you have said of it.—Yours faithfully,
THOS. SUTTON.

St. Brelade, Jersey, January 3rd, 1863.

[We have pleasure in inserting Mr. Sutton's letter, and take occasion to add one or two remarks on the subject. Whilst we shall have much pleasure in ventilating the subject fully, we would suggest that, until the complete specification of any patent is published, any question either as to its validity or efficiency is premature. And again, it should be borne in mind that the protection of any invention or discovery by patent is by no means necessarily a deprivation to the public, but often the contrary. If, for instance, a patented article be manufactured well and cheaply, the public are gainers by having the matter kept in good hands, instead of being at the mercy of many of those who, having no reputation in connection with the invention to lose, manufacture it with a view to profit rather than efficiency. Taking a patent is a more liberal course than maintaining a secret. The piece of paper enclosed forcibly illustrates the fact, that preparing paper with india-rubber and albumen is by no means all plain sailing. As we had before conjectured, Mr. Sutton intends permitting amateurs to use his patented process for their own prints with impunity. It is simply the commercial use he reserves to himself.—ED.]

TRANSMITTED POSITIVES, REVERSE ACTION OF LIGHT.

SIR.—The letter of your Paris correspondent in a recent number of the *News*, page 8, reminds me of a circumstance which happened to myself on one of the very fine afternoons we enjoyed last Autumn. I was exposing a trial plate (Fothergill), the subject rather a difficult one to bring out, being the front of my house—white, with a middling sized yew tree before it, two broad carriage drives coming to a point at the yew-tree, and a foreground of grass with dwarf bushes of laurustinus box and yew scattered over it—in raising the slide I incautiously allowed the back to be lifted about an inch, thus admitting a momentary flash of light to the interior of the camera, and by reflection thence, to the sensitive tablet; however, I went on, exposed the plate in the regular way, and took it back to the yellow room, where I developed a *positive by transmitted light*. The collodion was not very suitable for the Fothergill process, and the picture not a very good one, the sky being much marbled, but every spray of the dark evergreens is well made out, and so is the white house in the back-ground.

With the exception of the dash of light into the back of the camera, the manipulations and chemicals were the same as I generally make use of for negatives, and they have no novelty to photographers. I may mention, however, that the bath was slightly acid with acetic acid, and the developer was pyro and citric with a little nitrate of silver.

About six years back, when using the waxed paper process, I met with a somewhat analogous circumstance. A negative I was developing began to come out so foggy and bad that I took it from the bath and threw it into the open air. It caught my eye by accident two or three minutes afterwards, when, to my great surprise, it was developing into a positive so beautiful in half-tone, and other artistic qualities, that I have never seen anything in photography to equal it. I tried anxiously to fix it, but all the beauty disappeared in the hypo as rapidly as it had been developed. Very truly yours,—
RHO DELTA.

January, 6th, 1863.

Photographic Notes and Queries.

INSTANTANEOUS DRY PLATES.

SIR,—From the facts that are recorded from week to week in your Journal, it would seem that the problem of producing instantaneous dry plates will ere long be solved. I wish to suggest a probable method by which those plates may be produced, and some of your numerous readers may perhaps test its value before I shall be able to do so myself.

Mr. Keene and Mr. Frew have just published their plans of making tannin and honey, and tannin and gum plates still more sensitive, by leaving free nitrate in the film; theoretically, Mr. Frew's method seems the best, being less likely to produce unequal sensitiveness. Mr. Sutton's gum process is even more rapid than the above. Major Russell and others have also found the use of ammonia in the developer to lessen the required exposure.

I would therefore suggest that the plate be coated with Sutton's collodion, and excited in a bath containing no more acid than absolutely necessary, and thoroughly washed. Next, that it be coated with gum preservative newly made, to which $\frac{1}{2}$ drachm of a 30-grain solution of nitrate of silver and $\frac{1}{2}$ grain of citric acid has been added. Ammonia development at a moderately warm temperature would complete the process, which, from the facts I have cited above, should give rapid results.—Yours truly,
W. H. HARRISON.

Hivest, December 30th, 1862.

NEW MODE OF PIRACY.

SIR.—A species of piracy has lately made its appearance, which, if unchecked, is calculated to effect considerable injury to the numerous class of persons who gain their bread by the honest exercise of their professional abilities. I allude to parties extensively advertising for prints of cartes de visite, and other portraits, with a view to furnish the owners with a great number of copies at a reduced price. It is true that, with individuals who can appreciate and value a first-rate production, such a scheme will find but little favour; as a copy, however well it may be executed, can never be made to compare, satisfactorily, with a proof from the original negative. But the mischief arises from the fact that, to a great many persons requiring photographs, excellence of execution is of only secondary importance compared with the temptation of getting a great number for a little money.

I herewith send a vignetted "carte," which was furnished to a customer two or three months ago, for 3s. 6d.; future prints would have been 1s. each, or 12s. the dozen. I do not think this charge excessive for a good picture; and most persons, after taking a similar negative, would have reasonably expected to furnish 10s. or 15s. worth of prints from it. My customer, however, sent the print to a pirating establishment, got it copied, and received fifty proofs (such as they are), post free, for half a crown! the name of the copyist being substituted for my own on each of them.

Now, sir, I have no desire to comment on the moral attitude assumed by the respective parties to this transaction. To me it seems a simple act of robbery on the one hand, and of very great meanness on the other. But this is only my own

private opinion; and, as I fear I may be a considerable sufferer by such practices, I am anxious, if possible, to hit upon an efficient remedy.

The new Copyright Act enacts that any person executing a photograph, by order of another person, shall not be entitled to copyright therein, except an agreement in writing, expressly reserving such copyright, be signed by the parties at the time the work is executed. I, therefore, propose having a book, with a general form of agreement, written on the first page, followed by the signatures of parties for whom negatives are taken—non-compliance being the subject of an extra charge. I should thus be furnished with the legal means of punishing parties who infringe my copyright. I should be glad to know if you think this plan efficient and possible? I am pleased to find that unscrupulous copyists receive no mercy at your hands; and if you think the insertion of this note of sufficient interest to photographers at large, and likely to assist in exposing such practices, I have no objection to your publishing it.—I am, sir, your obedient servant,

FAIR PLAY.

Poole, January 17th, 1863.

[We apprehend that if sitters will consent to such an arrangement, and the pictures be registered, the plan will protect portraitists. The agreement should be so worded as to protect the public as well as the photographer, and secure sitters against the publication (without permission) of their portraits.—ED.]

To Correspondents.

* * Wanted, for full prices, or in exchange, the following numbers of the PHOTOGRAPHIC NEWS:—6, 9, 41, 49, 76, 80, 81, 91, 101, 104, 127, 197, 198, 200, 202, 203, 213, 214, 215, 216.

NOTICE.—With a good lens, and judicious manipulation, it would be possible to get a group of fifteen figures sufficiently sharp in a small negative to produce a good enlarged picture. 2. The precise details of composition printing vary in different hands. Each figure or group of two or three figures is taken on a separate negative, the general design and relation of each part to the whole having been determined beforehand. Each negative in succession is then printed on a sheet of sensitive paper sufficiently large for the whole picture, the whole of which is carefully covered from the light except the figure to be printed in, which in its turn is covered until all are finished. The mode of masking or covering up may be varied according to the ingenuity of each manipulator; the subject is too lengthy for detail in this column. Much depends on circumstances as to which plan would be best for a large group, a small negative of the whole enlarged, or a composition picture. The first would be probably the least trouble, the latter, in good hands, would probably give the best picture.

C. Upton.—Mr. Sutton's recent work is a very good one. The other works you name, especially the new edition of Bland's "Practical Photography," are very good.

F. L.—The advantage of a portrait lens over a view lens, as regards rapidity, arises from the fact that they may be used with a much larger aperture than the latter.

MR. G. S. PENNY offers a suggestion relating to alleged spirit-photography. He says:—"My request is that our cousins who operate on this particular class of subjects would send us for inspection a binocular picture of a material and spiritual pair. No polite spirit, so condescending as to submit to the scrutiny of one lens, would, I am sure, offer any objection to a sitting before a pair of lenses, provided no greater tax were made upon its time; and it would afford us valuable information as to its whereabouts, if not of its nature." Regarding Spenser's magnetic filters we cannot, unfortunately, give you information, as the subject has not come under our attention.

THOS. COLLINS.—We have more than once in different places called attention to the fact to which you refer, which is one well recognized by experienced portraitists both in photography and painting. In our own observation the nose slightly inclines in the majority of cases, to the right side. Thank you for the paragraph, which may be useful to many. We will make use of it. Thank you also for the suggestion regarding the YEAR BOOK. It is one we have more than once thought of; our chief ground of hesitation, hitherto, has been the desire not only to make it useful to all classes of photographers, but to keep it within their means.

J. R. IRATON.—It is not necessary to varnish glass transparencies, unless from slight over-exposure, or from over-development, or from something in the condition of the film, they seem to require it. If it be deemed necessary, any good varnish giving a glassy, textureless surface will do. The fine ground-glass for transparencies may be had of most of the dealers in photographic glass, such as Claudet and Houghton. Crystal varnish, with a little white wax added will answer the same purpose, as will also a little thin colourless starch.

AN AMATEUR.—Your negative is considerably under-exposed. In toning, the print should be immersed, not floated. If the bath be in proper condition ten minutes will generally be amply sufficient to tone a print; but in all cases the colour, rather than the time should be the guide. Always see that the print is sufficiently toned before removing it.

EXCELSIOR.—The addition of cyanide of potassium to a nitrate bath would simply cause a precipitate of cyanide of silver, which is insoluble, and after filtration no harm would be done beyond slightly weakening the bath. It has been recommended for purifying a bath, and is considered by some a valuable secret dodge. The cyanide of commerce is, however, so impure that it is difficult to say with certainty what the effect of adding it would be. In the case you describe, it is probable no great harm is done. Try the bath, and ascertain, if it work unsatisfactorily, sun it, and add a little nitric acid. 2. It is very easy to keep an iron solution for developing

positives a few months without much deterioration of its developing powers. Make the solution concentrated, 50 grains or more to the ounce, and add half as many minims of glacial acetic acid as there are grains of the iron salt. Keep it in a well-corked bottle, always inverting it, or placing it bottom upwards, so that the solution then flows round the cork, and less air is admitted than if the bottle were upright. The only change which will take place may be a slight amount of peroxidation, which will slightly weaken the developer, but will also, in our opinion, make it give a better positive. Dilute for use with once or twice its bulk of water, adding a drop of nitric acid for each ounce. Such a developer will give bright positives. Report on your glass in our next.

A CARLISLE SUBSCRIBER.—The best mode of rectifying the condition of a collodion which gives comets, is the addition of a little bromide. From a quarter of a grain to half a grain per ounce of collodion will generally make them disappear. If the defect arise from floating particles there is nothing but filtration, or settling. The collodion filter is said to be useful, but we have never tried it, always preferring subsidence for turbid collodion.

W. G.—Thank you for the cutting, we shall make a note of the case. We have not worked the morphine process, and cannot with certainty state the cause of the watered silk markings. Perhaps our correspondent Mr. Bartholomew can help you. In some other dry processes a similar defect is sometimes found; various suggestions as to its cause have been offered; but the most efficient remedy is, we believe, the use of an older collodion. 2. A single view lens of 6 inches focus, if worked with a large aperture, say half an inch, will, in a good light, and with first-class chemicals, in good order, give instantaneous pictures; but so far as we know, the particular lens you mention will not do it better than any ordinary good single lens.

ANGUS.—We are always obliged to any one, whether friend or enemy, who points out an error. The wish and attempt to do so without success, however, merely shows incompetency and spite. One or two of the statements were correct, and the result of a printer's error. Such, for instance, as P. for platinum, which should have been PL, as the opposite page shows. The other remarks present some curious blundering in the writer, but it is not worth while to answer them. Various authorities state equivalents differently. The list of inconsistencies and blunders in the similar table given in the other little publication you name are amusing enough; but we don't care to make reprisals. Besides, it would be breaking a fly on the wheel to criticise it. It is a compliment that ours is selected to examine for errors rather than the more abundant field at home.

W. G. H.—If you cement over the water-tight top a thin sheet of gutta-percha, or a piece of vegetable parchment, that is, parchmentised paper, it will prevent the sticking of the india-rubber.

W. WILSON.—There is no disadvantage, except the expense, in using any quantity of alcohol in the developer which does not precipitate the iron; neither is there any advantage in using more than is necessary to make the solution flow without causing greasy lines. 2. In introducing a ghostly figure into a photograph, let the figure enter for a few seconds at the close of the exposure, so that the figure may appear superposed upon the image already impressed, the first image being seen, as it were, through the last, giving it an unnatural or transparent effect.

J. H. UNDERWOOD.—We shall take an early opportunity of noticing your charming slides. We think it decidedly wise to publish them.

SIGILLI.—The plate sent had the appearance of having been left some time in a bath imperfectly saturated with iodide of silver, the film being consequently deprived of its iodide. The bath, however, smells very strong of ether, as if it had been much used. On trying a plate with a good sample of collodion in the bath, universal for was the result, indicating the presence of organic impurity. We added a solution of bicarbonate of soda, a little at a time, until there was a slight turbidity, which no longer dissolved on agitation. We then placed the bottle in the sun for an hour or two. The solution darkened very considerably, and threw down a black precipitate. The solution was now filtered into a bath, and a plate tried. The result was a clean, bright, good image. You may doubtless trace the remainder of your large bath in the same way with like success. 2. The collodion appears to be simply iodized, and has a tendency to give comets. The addition of a trace of bromide removed this. Adding a little of some bromo-iodized collodion will answer the same end.

J. ALEXANDER.—The stops of lenses are made black by a solution sold by chemists as "chemical bronze," which consists, we believe, of a solution of bichloride of platinum. The metal should be made quite clean and free from grease, and slightly warmed. The solution is then applied with a camel-hair brush. When dry apply a little blacklead with a brush. The tanning process, or the collodio-albumen process will probably answer your purpose best.

J. H.—You will find several articles in our last volume on the details of producing photographic transparencies. They are too lengthy to be given in this column. If you have not the volume we can refer you to the numbers.

JOHN SHELTON.—We fear the volume of "Photographic Proverbial Philosophy" will not be published.

E. C. LOCKE, D. M. A., CHARLES DERBY, SAMUEL FRY, and several other Correspondents in our next.

Photographs Registered During the Past Week.

By MR. GEORGE JAMES KEEL, 92, Renshaw Street, Liverpool.

1. Vignette Portrait of Rev. Robert William Forrest.
2. Ditto large half-length.
3. Ditto small half-length.

By MR. JOHN THORPE, 20, Grand Parade, St. Leonard's-on-Sea.
Carte de Visite of Roger Cooper Gardiner, Esq.

By MR. FRANK REYNOLDS, Churchtown, Dundrum, county Dublin.
Portrait of Garibaldi leaning on a spade, and surrounded by his goats.

By MR. EDWIN THOMAS HICKS, 45, Mackenzie Street, Everton, Liverpool.
Vignette Portrait of Barry Sullivan, as "Hamlet."

* * * THE Publisher desires to call the attention of photographers sending photographs for registration, to the instructions given in No. 225 (see p. 613). The photographer should himself fill up the form and sign it. It is also especially desired that care be used in writing proper names to secure legibility, as, otherwise, errors detrimental to the validity of a copyright may occur.

THE PHOTOGRAPHIC NEWS.

Vol. VII. No. 230. — January 30, 1863.

CONTENTS.

	PAGE		PAGE
Private Photographic Exhibition at Nottingham	49	Copyright of Photographs	55
Another Toning Bath with Gold and Lime	49	Proceedings of Societies	56
The Photographic Exhibition—Third Notice	50	International Exhibition.—Report of the Jury on Photography and Photographic Apparatus	57
Printing Difficulties. By a Photographer's Assistant	51	Correspondence.—Foreign Science, &c.	58
Researches in Heliochromy. By M. Niepce de Saint Victor ...	51	Photographic Notes and Queries	59
Memorandum of a Photographic Trip in Norway. By the Rev. Arthur Cotton, M.A.	53	Talk in the Studio	60
On the Action of Nitrate of Silver upon Albumen. By MM. Davanne and Girard	53	To Correspondents	60
A Short Lesson in Photography.—No. 8	54	Photographs Registered during the Week	60

PRIVATE PHOTOGRAPHIC EXHIBITION AT NOTTINGHAM.

WE have received a large number of inquiries regarding an announcement which recently appeared in our advertising columns, and has been also widely circulated by means of circulars, referring to a projected photographic exhibition at Nottingham. Not a few of our correspondents suspect the scheme, others denounce it very freely, and some send for our private information particulars of a very damaging character.

When the matter first came under our attention, we must confess we viewed it with some degree of distrust. But, as it is *not* "our nature's plague to spy into abuses," we felt disposed to pass the matter by without further question or notice. The projector of the scheme, however, asks our opinion on the subject, and our consent to assist in adjudging prizes. We might have answered privately; the inquiries of many correspondents compel us, however, to adopt this method, and if we do not supply injurious information, we must at least offer an opinion. That opinion is in no sense favourable to the scheme proposed. In the first place, this is purely a private speculation. At the invitation of an unknown private individual, residing in a provincial town, photographers are requested to send him their productions for exhibition or sale. A "Contributors' Guide" is offered on receipt of six postage stamps. This, when received, consists of a circular of three octavo pages, containing the conditions of exhibition, one of which is very singular, and runs thus:—

"5. All articles intended to be competed for must be entered in the Secretary's book before the 1st of March, the charge being One Guinea, which shall be used for purchasing fifteen prizes, and procuring three impartial judges to be chosen by a majority of the contributors."

To say the least of it, such a system of raising the money for prizes, even if adopted by a responsible society, is vicious in the extreme. For the satisfaction of contributors it is announced:—

"3. That this exhibition will be protected by a joint stock company of five shares of twenty pounds each, to defray all expenses not covered by the charges on admission and *voluntary contribution*."

How the "joint stock company" is to protect the exhibition is not quite clear, neither is it clear whether such a company exists, or is yet to be formed. There are some other curiously worded conditions; but it is unnecessary to pursue the matter further. Neither do we intend to make use of the information forwarded to us bearing unsatisfactorily upon the projectors of the scheme. Whatever the respectability of the persons, the proposition is a blunder. Photographic exhibitions can rarely be successfully got up in provincial towns; but if the thing be a possibility at all, it can only become so in the hands of an active photographic society, of whom it is the legitimate province to manage such undertakings. When such a project is

attempted by private individuals, they lay themselves open to the suspicion of some kind of trade scheming for private purposes; and in this attempt the mode of procedure, and the conditions laid down, are such as cannot fail, we apprehend, to destroy confidence, and issue in entire failure.

ANOTHER TONING BATH WITH GOLD AND LIME.

M. JEANRENAUD proposes a modification of the toning bath. Considering that the process by *chloride of gold* and *acetate of soda* weakens the depth of the tones obtained by proper exposure, necessitating over-printing, he has sought a process free from these objections. He fills one bottle with

- A. Distilled water 9 ounces
- Chloride of gold 15 grains
- B. And another with distilled water 1000 grains
- Acetate of lime 10 grains.

The positives are printed strongly, then freely washed in rain water, and the toning bath is prepared in quantity proportionable to the number of proofs to be fixed. Thus for 2 or 3 proofs 12 by 10, take one ounce from bottle A and add to it two ounces from bottle B, and place the mixture in a porcelain dish, over a spirit lamp. When the liquid becomes heated it gives off faint nitrous fumes, which are immediately succeeded by a slightly acid vapour, arising from the acetic acid. The liquid soon becomes colourless, and commences to boil. A combination now takes place, and in this state the chloride of gold has no longer that corrosive action upon the proofs, which causes so many to be rejected. This operation is very rapid, as only very small quantities of liquid are made to boil at a time. The ebullition must not be prolonged beyond a few seconds, because the liquid, which becomes colourless just at the moment it comes to the boil, has then a tendency to become *yellow*, and thick, and in that state acts with less regularity, and may weaken the proofs.

The gold solution is now ready for use; it is only necessary to add sufficient distilled or rain water to immerse the proofs in, pressing them down below the surface with a glass triangle. It is best to keep a glass dish specially for the bath. The time required for toning depends upon the quality of the paper; a quarter of an hour suffices for French paper, half an hour for German; but with the latter the tones have much more strength and solidity. Lastly, to take every precaution against sulphurizing the proofs, before fixing them with a solution of hyposulphite of soda, strength 20 per cent., they may be passed through a bath containing a solution capable of neutralizing acids, such as water containing 6 or 7 per cent. of bicarbonate of soda.

This process is very economical, as with 15 grains of chloride of gold 25 to 30 half sheets may be toned. It is very convenient for amateurs, who, not having a large number of proofs at a time, require new baths frequently, and the consumption is in exact proportion to the work performed

as the solutions are kept separate until the moment they are required for use.

All the other acetates, such as those of strontian, barytes, and zinc, give nearly the same results; but the acetate of soda employed in this manner does not appear to combine with the chloride of gold, which it does not render colourless, at least when employed at 3 per cent., and it also acts very slowly.

THE PHOTOGRAPHIC EXHIBITION.

THIRD NOTICE.

WE have received numerous communications, from operators and others, regarding the opening of the exhibition in the evening, seconding our remarks, and urging us to press the subject on the attention of the authorities. We find those gentlemen upon whom the responsibility depends are most anxious to afford every facility, to every class, for visiting the exhibition, and profiting by the pictures exhibited. But opposing their desire to open in the evenings, they find the stern fact that, on former occasions, the cost has been greater than the receipts. As a means of meeting the difficulty, however, it is in contemplation to keep the exhibition open in the evenings during the last fortnight of the season. We cannot promise this as an absolute certainty, but believe that the authorities are so far desirous to meet the wishes of the photographers, that they will undertake this even at the risk of a little loss. Due announcement of the fact will be made.

We hope, before long, to be able to announce the decisions of the adjudicators in reference to the prizes to be awarded. The gentlemen who have undertaken this delicate task are pre-eminently well fitted for its satisfactory discharge. Mr. Joseph Durham, photographers know as a sculptor of eminence, a gentleman of highly cultivated taste in art, and a member of the council of the Photographic Society. Mr. Roger Fenton is known as a very able photographer, and one of the chief founders of the Photographic Society, and, having recently retired from the actual practice of photography, his decision must be free from the slightest suspicion of personal bias. In case of difference of opinion between these two gentlemen, they will elect an umpire to decide. The council have enlarged their intention, and six medals will be given instead of four, as was originally contemplated. These will be thus distributed:—

1. For the best portrait, or portraits.
2. For the best landscape, or landscapes.
3. For the best instantaneous picture, or pictures.
4. For the best contribution by an amateur.
5. For the best composition picture from life.
6. For the best reproduction or composition from still life, or copy of paintings in oil or water-colours.

In regard to several of the subjects there is sufficient distinctive superiority as to make the decision comparatively easy; regarding the landscapes, however, there are several so nearly balanced that the task of selection must be very difficult. We will not, however, anticipate the decisions.

Proceeding with the chief contributions in the order of the catalogue, we find a series of reproductions from paintings by Mr. M. H. Phillips. These are very excellent as reproductions, but the especial point which strikes us is the singularly photographic effect of some of the pictures. Here are two copies of pictures by MacCullum, "Autumn" and "Winter," either of which might very easily be mistaken for photographs from nature. The "Autumn" is a little dark and heavy, from the profusion of rich and warm colours in the original; but the "Winter" is an admirable picture, with a perfect *resemblance* which suggests forcibly the idea that the original was painted from photographic studies. Mr. G. R. Mainwaring has several frames of flowers and fruit, grouped with great taste, and exceedingly well photographed. These do not generally exceed the half-plate size, and are much more suitable for such subjects

than the large photographs of similar subjects exhibited by Mr. Fenton two years ago.

Still, amongst the finest landscapes are the contributions of Mr. Mudd. They are always well chosen and picturesque subjects, and, generally, at once brilliant, soft, and atmospheric. No. 29, the "Hermitage Bridge, Dunkeld," across the Braan, if we remember rightly, is a wonderful study of foliage, water, and large boulders. The thick masses of foliage are rendered with perfect detail, the water is transparent, and the large light-coloured stones in the foreground free from the slightest chalkiness. "Castle Crag, Cumberland" (No. 48), is another charming picture. Mr. J. H. Morgan has some very excellent landscapes. A couple of "Studies of Sheep," from life (Nos. 26 and 27), are very good, and giving just the head and bust, have a quaint and amusing effect. Mr. Mayland exhibits some fine landscapes of views in and about Cambridge, and some good interiors of difficult subjects, which have before been noticed in our columns. The Hon. W. Vernon exhibits some pretty good landscapes, but which do not, on the whole, justify that gentleman's reputation. Messrs. Fothergill and Branfill exhibit a number of pictures, from tannin plates, of scenes in Genoa. The majority of these have been exhibited before; they are clean and bright, wanting a little atmosphere, and sadly defaced with white-paper skies. "The Pieta," by Michael Angelo (No. 41), is a charming picture of a fine relief. Mr. C. Alfieri exhibits some good and some indifferent landscapes, those of "Furness Abbey" being best. Lady Jocelyn exhibits some views of Broadlands, Hants, which are delicate and detailed, but some of them a little wanting in atmosphere. One is a charmingly sunny thing, the fantastic shadows of foliage on a wall almost seem to flicker before the eyes. Mr. D. Combe exhibits a figure of a mounted volunteer, which is beautifully soft and round, but a little stiff and formal in the lines. Mr. Eidman exhibits a view of St. Martin's Church, from Pall Mall, intended to represent twilight. It is wanting in transparency, and looks dingy. Mr. Stephen Thompson exhibits a large number of landscapes, and some statuary. Amongst his contributions are many excellent pictures, of which we shall have to speak further, but many of them, especially those immediately before us, have the unfortunate fault in lighting, of which we have before spoken in this gentleman's productions, which gives them a flat and monotonous effect. "Kelso Abbey" (No. 31), "Tarsel Bridge, Flodden Field" (No. 40), and "At Richmond, Yorkshire" (No. 54), are notable examples of this characteristic.

Another little genre picture (No. 45), which, being unfortunately hung very high, is likely to escape attention, is well worthy of notice. It is entitled "A Happy Dream," and is by Messrs. Ross and Thompson. A pretty child lies sleeping, with happy peaceful countenance. A fairy-like female figure bends, or hovers about it, suggesting the idea of the "Angel's Whisper," as described in Lover's ballad. The general *ensemble* of the composition is good, and the transparent immaterial effect of the angel visitant is well managed. We commend this effect to the attention of Bullock Brothers, who made a great mistake not to call their "Footsteps of Angels" simply a fire-light effect, as which it would have won golden opinions. We regret that the hanging of "A Happy Dream" does not permit a more detailed examination.

We conclude for the present with a brief analysis of the processes represented in the exhibition. The number of contributions which are hung is larger than on any previous occasion, 825 frames being catalogued, whilst between one and two hundred have not found places. This shows an excess of contributions exhibited over the last exhibition of not less than two hundred frames. Wet collodion is now almost universally used, the proportion of other processes being less than ever. Upwards of seven hundred of the present contributions are by wet collodion; twenty-five by the collodio-albumen process, the chief of these being by Mr. Mudd; eighteen by the tannin process; eight by Dr. Hill

Norris's plates; twenty by the waxed paper process, all these being by French contributors; sixteen by various carbon and photolithographic processes; five by the Fothergill process; four by the tannin and malt process; two simply described as dry collodion; two by the honey process; two by the collodio-albumen and honey process; two by the metagelatin process; two by Corbin's collodionized paper process; one by the morphine dry process; one by the albumen process; and half a dozen daguerreotypes. The numbers of course refer to contributions or frames, which in many cases include several pictures. It is a somewhat singular fact, that whilst dry collodion processes have occupied so large a share of public attention, they are so meagerly represented here. In excellence, however, the dry processes present a more satisfactory result; some of the best pictures in the exhibition having been produced by the collodio-albumen and tannin processes, and their modifications. The Fothergill process puts in a very poor appearance this year; of the small number of contributions the majority being very poor indeed. The process has evidently been declining in popularity, and the results here exhibited will not be likely to give it a fresh impetus.

PRINTING DIFFICULTIES.

BY A PHOTOGRAPHER'S ASSISTANT.

THE advantages derived from the method described, for separating a portion of the chlorine from the gold, cannot be too highly estimated, as it gives us entire control over the bleaching power necessary to be exercised in toning operations; by the addition of soda in excess, the same results may be obtained; but, beyond a certain point, our controlling influence is lost, or at least uncertain in its operations. To those who have not made the science of chemistry their study, it may appear strange that the application of heat, whilst separating a portion of the chlorine, leaves the solution in a condition as acid as before, thus rendering necessary the same quantity of soda to produce an alkaline reaction; for the information of this class of inquirers, I shall endeavour to explain the reason why the separation of chlorine has no influence on the acid introduced with the gold into the toning solution. The chloride of gold usually sold for toning purposes, is made by dissolving a portion of the metal in a mixture of nitric with hydrochloric acids, or what is termed aqua regia: from the hydrochloric acid it derives its three equivalents of chlorine, so that, when separated by evaporation, it exists as a perchloride plus free acid in uncertain quantities; and this acid, which is a mixture of chlorine, hydrogen, nitrogen, and oxygen, we have reason to believe, separates itself from the chloride of gold immediately it is brought into contact with water; so that the heat, whilst exercising its decomposing influence upon the chlorine in combination with the gold, leaves unmolested the free acid, be its quantity great or small; consequently the same proportion of soda is required to produce alkalinity as would be required with the gold when in combination with its full amount of chlorine. Strictly speaking, the presence of soda with the perchloride is unneeded, whilst this last-named substance is undergoing the process of evaporation. But I am inclined to think that the presence of a small portion of soda hastens decomposition, not by its combination with the liberated chlorine, but by combining with the free acid it prevents the gold obtaining a fresh supply of chlorine from this source; so that, when a toning bath is to be used directly, it would, doubtless, be an advantage to add a larger quantity of soda than I have before named, the quantity being regulated by the amount of reduction required; but in no case where heat has been applied should the solution be strictly alkaline; for, except a trace of the stronger or the more faintly marked liberated carbonic acid be present, toning action will proceed but slowly indeed. It should ever be remembered, that the presence of an acid increases the bleaching power possessed by the toning

solutions, and here I would suggest, that this application of heat be resorted to for the purpose of giving the necessary qualities to the toning solutions hitherto considered unfit for use, until they have undergone a term of probation in penitential solitude upon some dusty shelf (not making use of those fanciful solutions, I merely give this hint on theoretical grounds).

Before proceeding with the details of my recent experiments, I would just observe, that I shall have occasion to offer remarks that may lay me open to the charge of inconsistency, they being somewhat at variance with the teachings contained in my letters recently published: but, be it remembered, I have been, and still am following, an almost unbeaten track; and, as I grope my way, I heed not the stones behind, though they for a time have supported my faltering steps, fixing my eyes steadily upon the goal of entire, undoubted knowledge of the subject, and throwing aside theories, useless as they are lumbering; after their work is accomplished, stepping from stone to stone, I move slowly forward, at the same time giving the photographic world the benefit of the faint gleams of light that have dawned upon my mind; and as the amount of light increases, I bring my increase of knowledge (if increase it be), and humbly add it to the stock of information contained in that best of photographers' hives, viz., the PHOTOGRAPHIC NEWS.

And now, without further remarks, I proceed to tone the prints described in the former portion of this paper: for, by this time, the solution is cold—or, at least, lukewarm—a condition most suitable for the present season of the year. Pouring this solution into the porcelain dish, for the sake of further tests, an addition of soda was made from time to time, commencing with half a grain, which, of course, left the solution still in an acid condition. The prints, which had been all printed the usual depth, viz., a full allowance made for reduction, I now commenced exposing to the action of the toning bath. No. 1, short floating, on sensitizing solution, became faint and slaty, with mealiness, though in a greatly modified form. No. 1, long floating, on ditto, retained a large portion of vigour, but still a faint trace of the same description of mealiness. The other prints followed in succession; those floating upon the strongest bath, though reduced rapidly, gave no trace of the disease until the slatiness began to appear. I now added another half a grain of soda to the bath. The reduction was not so rapid, but dark tones could not be obtained until mealiness in somewhat the same form made its appearance in the light background of the pictures; and now another half a grain was added—making in all three grains of carbonate (not bi-carbonate, remember) of soda to the grain of gold; the prints now toned more slowly, increasing rather than diminishing in vigour; those floated on the strong solution giving the most satisfactory results, although, for want of the strong bleaching power, all retained their over-printed appearance. This was just what I was in search of, a process that would give vigorous prints without any over-printing.

(To be continued.)

RESEARCHES IN HELIOCHROMY.

BY M. NIEPCE DE SAINT VICTOR.

FIFTH MEMOIR—CHAPTER .

On the Reproduction of Colours in Heliochromy.

I now state the results of the observations I have made during the past year, and, although the summer has not been favourable to my experiments with the camera obscura, still I have been able to obtain some proofs.

The obtaining of colours in the camera obscura best shows what heliochromy can give us; for here there can be no illusion, heliochromy cannot reproduce everything; but, nevertheless, it can give us many things; and thus it is

that I have the honour to present some proofs to the Academy, and, at the same time, of showing my mode of preparing the plates.

I have always found yellow the colour most difficult to obtain in the same space of time as the other tints; but I have recently discovered the means of developing the yellow with certainty, and of obtaining it in the same time as other colours. I had previously obtained, with great facility, red, green, and blue; but when yellow was produced, it was accidentally.

I have arrived at obtaining yellow in all my reproductions, by employing, as an agent for chloridizing my plates, a bath composed of hypochlorite of soda, in preference to the hypochlorite of potassa. This bath must be in the following conditions:—

Take a newly-prepared hypochlorite of soda, marking six degrees of the areometer; dilute it with one-half its bulk of water, and then add alcohol in quantity equal to $\frac{1}{2}$ per cent. of the soda, and heat the bath to a temperature of 180° to 190° F; then pour it into a flat capsule, half-plate size, stirring the liquid for a few seconds, immerse the plate in it at once, a time sufficient for the plate to take a black tint. It is then rinsed in abundance of water, and dried over a spirit-lamp.

In 200 grammes ($6\frac{1}{4}$ oz.) of this bath we can chloridize five or six quarter-plates, among which some will give better results than others, according to the thickness of the film and the degree to which the plate has been heated. In these conditions of chloridization the colours are produced (especially by contact) with very vivid tints, and, very frequently, the blacks appear in their full intensity.

To operate in the camera obscura, we select plates which, by the action of heat, have received a fine cherry-red tint, as well as those which are more slightly reheated, because they are the most sensitive to light. On this account the film of chloride of silver must not be too thick. But, to obtain the effects which I now describe, the chloridized plate must be covered with a varnish with a base of chloride of lead, as I pointed out in my last report, only we must take an aqueous solution of dextrine with chloride of lead, in order to neutralize the action of the alkaline bath upon the chloride of silver, and whiten the ground of the picture, which, without it, would remain rose colour, or dingy.

With regard to the problem of fixing the colours, I have only succeeded in doubling the time of duration announced in my last report. Many substances, added after the action of heat upon the chloride of lead, give a greater fixity than if the chloride of lead was alone; such are, among others, the tincture of benzoïn, chloride of tin, and aldehyde. But what has given me the best result is the tincture of Siamese benzoïn, applied to the plate while it is yet warm, and, after the plate has become dry, heating it until a little of the benzoïc acid is volatilized.

It is by means of this lead varnish that I have been enabled to preserve colours during three or four days, in an apartment strongly illuminated by daylight, in the month of July.

One observation I made is, that if we incline a heliochromic image, at a certain degree of incidence, the colours appear much more vivid, and the blacks assume the greatest intensity.

I have also remarked that, according to the manner in which the model (a doll) is illuminated by the solar rays, the obtaining the colours in the camera obscura becomes singularly modified, and produces very advantageous effects as to intensity of colour and brilliancy; as, for example, gold and silver lace, precious stones, &c.

But what is very extraordinary, is that, having placed a strip of unglazed black paper upon a large piece of silver lace, which the doll wore as a belt, the black of the paper was reproduced with the white of the silver lace.

Black is reproduced with a violet hue, viewed direct; but, if the plate be inclined at a certain angle, it assumes its greatest intensity, and the silver lace its metallic splendour.

Light, in changing the heliochromic colours made, in certain cases, changes green into blue, and yellow into green; as, for instance, if we cover them with a varnish having chloride of tin for a base, which, moreover, greatly retards the activity of the light; if it had not this objection, it would serve as a temporary fixing agent, for the reds are preserved a very long time.

CHAPTER II

On the Heliochromic Reproduction of the Binary Colours.

I HAVE now to speak of a series of experiments, which I consider very interesting in a scientific point of view.

I have proved that all the binary colours are decomposed by heliochromy.*

If the green be natural, like that of the emerald, arsenite of copper, oxide of chrome, sulphate of nickel, green carbonate of copper (malachite), they are reproduced green by heliochromy; but if the green be a compound, like that, for example, formed by a mixture of Prussian blue and chrome yellow, or that of stuffs, dyed by means of a blue colouring material and a yellow, or of certain glasses coloured by blue and yellow pigments, these greens, I repeat, give blue only by heliochromy, either by contact, or in the camera obscura.

I will mention another conclusive experiment: a light blue glass, superimposed upon a light green glass, give, by transparency, a very fine green; but, being applied to a heliochromic plate, they only produce blue; whatever be the time of exposure to the light, or whether the blue glass be uppermost or below, the results are the same.

Certain kinds of green glass reproduce green very well; others give only blue or yellow effects.

A yellow-green glass at first gives a light tint of blue, then a light green tint, and, finally, a fine yellow hue.

A green and a yellow glass, superimposed, produce a yellow upon the sensitive plate.

There are also other examples: a red glass, superimposed upon a yellow glass, giving an orange by transparency, produce only red upon the sensitive plate.†

A red glass, superimposed upon a blue glass, giving violet by transparency, first produce a violet (because the plate is naturally red); then blue follows: the red being replaced by an orange green, also quickly reproduces blue.

A white paper, coloured green, by green leaves, or by sap-green, is reproduced only very slowly by contact; the sensitive plate remains red a very long time, as if the light had no action; and if the exposure be prolonged, a bluish grey tint is produced; the same result takes place if we attempt to reproduce natural foliage in the camera, such as, for instance, the herbage of a green meadow; but if the foliage be a blue-green, as, for instance, the leaves of the dahlia, the blue tint will be more vivid. If the foliage be yellow or red, like that of dead leaves, the colour reproduced will be a yellow or a red, more or less pure, according to the greater or lesser absence of the blue matter, which, with the yellow, constitutes the green colour of leaves, as demonstrated by M. Fremy.‡

Lastly, it will be very interesting to reproduce Chinese green by heliochromy; we shall then discover whether it be a pure or a compound green.

The dye of a peacock's feather is well reproduced in the camera, that is, the colour appears under a certain degree of incidence, now green, now blue.

* As M. Edmund Becquerel has reproduced the solar spectrum complete, does this not prove that the colours of the spectrum are not decomposed by heliochromy? and is it not reasonable to conclude that these colours are simple, and that the solar spectrum is not formed, as Sir David Brewster asserts, by the superposition of three monochromatic spectra—red, yellow, and blue?

† I propose to repeat these experiments upon a plate not reheated, in order to ascertain if the red be still reproduced in preference to the yellow.

‡ In all the reproductions by the camera obscura, there is always a greater or lesser quantity of reflected white light, especially in the reproduction of foliage.

MEMORANDUM OF A PHOTOGRAPHIC TRIP IN NORWAY.

BY THE REV. ARTHUR COTTON, M.A.*

IN the early part of last summer I spent a few weeks in Norway, and, although the weather was most unfavourable for photography, an unusual occurrence, perhaps my photographic experiences may be acceptable to any brother in the art who is contemplating a similar ramble in this hitherto little photographed locality. The process I adopted was wet collodion developed with iron; the collodion, Thomas's, with bromo-iodiser, and the exposure with one of Dallmeyer's triplets, of which I cannot speak too highly, the exposure with the X stop varied from one second to a minute. The mode of intensifying was that with tincture of iodine, followed by pyrogallic acid, and this, by painting on an edge of varnish to the negative, I was always able to carry out, without risk of the film splitting, after the picture was fixed and dried, thereby reducing the quantity of water, a matter sometimes of importance, and the list of chemicals required in the field.

The ordinary mode of travelling in Norway affords great facilities for working the wet process, but I regret I had not also with me a few dry plates. Boats and carriages are the railroads of the country, men and horses are provided by law for fixed stages, at a very cheap rate, so that the cost of posting from ordinary stations does not exceed twopence an English mile.

The carriage, as most people are aware, is not an omnibus, being constructed only to carry one, and affords little room for luggage. It has no springs, consequently photographic traps have to be carefully packed, and craftily arranged.

Behind the body is a board about twelve inches wide, and two feet six inches long, and my tent, which was one of Rouch's, and contained camera, chemicals, &c., for the day, was swung by means of stout straps underneath this, thereby diminishing the jar upon its contents. On the board my portmanteau was strapped, but nothing that could not bear jolting could be carried in it. As a proof of this, I might mention, that the screws of a fishing reel packed in it were jolted loose, and a box of flies were pounded up so completely as to leave little else but hooks and the fluff of feathers.

Between my feet, in the body of the carriage, was my store box of chemicals, glasses, &c., and here they were fairly protected, the spring of the shafts taking off the jolt, but only a small box can be carried in this position, as even a little weight here is felt by the horse, and becomes serious as he gallops, as a Norwegian horse does down the almost perpendicular hills which abound. Moreover, the width of this part of the body, which is shaped somewhat like a canoe, is inconsiderable, and provides no room for one's feet, which rest outside against a cross-bar, which extends from one shaft to the other.

The camera stands, fishing rods, &c., were strapped to the shafts.

By promise of additional drikke-penge, or drink-money, a mere trifle, to the boy who sits on the top of the portmanteau, I was able to stop on any part of the stage; but I seldom availed myself of this, in consequence of the almost incessant rain.

The straps which secured my tent to the carriage board also served as its knapsack support, when, as was sometimes the case, I took a man on foot over the hills, who was well satisfied with two marks a day, amounting to 1s. 8d., and went up hill with his load as easily as I could without one.

Having said so much as to the arrangement of my impedimenta, which are always serious matters to a photographer, I would only recommend future travellers to take unusual precautions to preserve their negatives by very careful pack-

ing. I was not provided with grooved boxes, having always safely carried my varnished plates with blotting paper between them; and some of my best pictures were ruined by the rubbing they were exposed to in the carriage.

I have only a few hints to give, as far as my experience goes, as to the most interesting parts of the country in a photographic point of view.

Bergen is about the centre of an extremely beautiful country. North and south of this town, and within a day's steam, is the best of that scenery for which Norway is famous.

First, there are fiords 50 or 60 miles in length running up to the very backbone of the country, which in Norway is a mountain chain at no great distance from the coast, and out of these fiords the mountains rise almost perpendicularly several thousand feet.

No. 26 is a poor specimen of this feature of the country taken during a heavy rain on a very gloomy day. There are waterfalls, of which No. 18 is an example, 900 feet in height, but dwarfed in the photograph, from the impossibility of getting such a view as to give an idea of distance.

There are churches of the quaintest style of architecture, if they are of any style at all. Of these I have two or three specimens. No. 30 is a view of a noble river, the Rauma. No. 21, a view of one of the farms which, up the country, supply the place of inns, and provide good accommodation for man and beast.

With ordinary weather, I should have taken a great number of (to me) most interesting pictures, but ill-health during part of my stay in the country, and bad luck in the weather obliged me to leave a great deal of work for a future opportunity, nor should I, had it not been for the request of my friend Mr. King, have ventured to lay before you the accompanying selections from my negatives, or thought of troubling you with these few observations.

ON THE ACTION OF NITRATE OF SILVER UPON ALBUMEN.

BY MM. DAVANNE AND GIRARD.

THE employment of albumen as an additional sizing for positive paper, in connection with the action it exercises upon nitrate of silver, and the modification which may result in the proofs, is a subject that very properly engages the attention of the photographer.

We have been much gratified at seeing that the researches made subsequent to those which we presented to the French Photographic Society, in December, 1859, have confirmed what we then said upon this subject. The Abbé Pujol has recently called the attention of photographers to the combination which takes place between albumen and nitrate of silver, a combination but little studied hitherto, but upon which we have made some experiments. M. Roussin has lately shown that this combination alone, and well washed, is sensitive to light; and that with it we have even been able to obtain positives on paper. He has also obtained negatives upon glass developed with gallic acid. Mr. Spiller has also confirmed this fact, which we had stated, that albumenized papers also retain silver in the parts unexposed to light, even after fixing and the most careful washing. We should doubtless have preferred that these authors had known and mentioned our previous researches; but, as we have referred to them, we need not enter upon further details.

The combination of albumen with nitrate of silver varies according to the strength of the silver bath. Thus, in treating 5 drachms of albumen with 5 drachms of nitrate of silver, we obtained very different precipitates, according as these 5 drachms of silver were dissolved so as to form solutions of 15, 10, 5, 2½, or 1 per cent. With the solutions of 10 and 15 per cent., the albumen is strongly coagulated; it gives a heavy, abundant precipitate, which may be collected on the filter in the form of distinctly separate pellicles.

* Read by Mr. W. W. King, at the North London Photographic Association, January 21st.

With weak solutions of silver, the quantity of the precipitate is much less considerable. A notable quantity of albumen remains in the bath in a state of solution. The portion precipitated is soft, gelatinous, and sticky. A rapid analysis seems to prove that the compound of albumen and nitrate of silver is much poorer in albumen when it has been formed in presence of a more dilute solution of silver, which readily explains, by this cause alone, that the albumen, less strongly coagulated, is carried off by the washings.

In view of these facts, we can easily understand that a weak silver bath allows a portion of the albumen to be dissolved without coagulating; it thus becomes charged with organic matters which alter it; and the proof, much less rich in the argento-organic compound, does not acquire that brilliancy and vigour of tone which is due principally to this compound.

This combination of albumen and nitrate of silver is analogous to that which it forms with bichloride of mercury. It is insoluble in water, and sensitive to light even after perfect washing. When the light is intense, the compound rapidly assumes a red colour, and soon bronzes; but a feeble diffused light produces no perceptible colour; and this explains why papers strongly albumenized, and which are not chlorodized in proportion, yield, under the same negative, and by the same light, proofs in which the contrasts are harsh, and the details in the shadows less distinct. Under the influence of light, therefore, a decomposition takes place, nitric acid is separated, while a portion of the albumen remains combined with the silver. This latter combination is insoluble in hyposulphite of soda, and the total of these facts gives us the theory of the formation of positive or negative albumenized proofs, even in the absence of every other salt of silver; but it remains to be explained why the best reserved whites of the positive proofs, after fixing and washing, still retain silver if these proofs have been taken upon albumenized paper, while they retain none if taken on paper simply salted.

Some experiments enable us to explain this anomaly. We have found that the quantities of silver thus retained upon white sheets of paper, and well fixed, vary in considerable proportion.

Whatever care may be taken even by fixing the compound of albumen and silver immediately after sensitizing, we have always found a certain quantity of silver which the fixing agent has not removed, and which is probably owing to the formation of a little sulphide of silver. Albumen is, in fact, a sulphurized body, which most frequently, in contact with hyposulphite of soda, disengages a very strong odour. The quantity of silver which thus passes to the state of sulphide is very inconsiderable. It is this which imparts to the whites of our proofs a light tone which perhaps can only be appreciated when these whites are in direct contact with the margins. But there are other circumstances which cause the quantities of silver retained in the albumenized papers to vary; these are the preservation of the paper and the action of diffused light.

For while a whole sheet sensitized and immediately fixed gave, upon analysis, only a quantity of silver equal to 0.010, that which had been prepared the day before, fixed under the same conditions, gave 0.020.

Lastly, another sensitized sheet, dried, and exposed for a few moments to diffused light, although it did not become discoloured, contained, after fixing, 0.016 of silver. The experiment, several times repeated, has always given, with some variations in the proportions, analogous results.

We have therefore to conclude:—

1. That always, when albumen is in presence of nitrate of silver, it forms a small quantity of a compound insoluble in hyposulphite of soda (probably a sulphide).

2. The time that elapses between the sensitizing of the paper and the fixing with hyposulphite of soda, increases the quantity of non-fixable silver.

3. Diffused light acts in an identical manner, even when it is too feeble to colour the proof.

Now we know that a good negative must not have absolute blacks; the light can then always influence the largest whites of the photographic proofs, all the parts of which must necessarily contain silver.

But we do not think that the presence of this minimum quantity of silver can have the least influence upon the keeping of these proofs; and we all know that a great many proofs have existed a good number of years and have not undergone any appreciable change.

In connection with this practical question, the proof of the persistence with which the silver remains allied to the albumen throws some theoretical light on the subject.

We now understand that albumenized negatives may, up to a certain point, be developed without the addition of nitrate of silver, because the albumen has energetically retained a certain quantity, while non-albumenized and well washed negatives can be made to appear only after the addition of the necessary quantity of nitrate of silver.

And, as diffused light causes a portion of this compound of silver and albumen to pass to the insoluble state in the hyposulphite of soda, we can easily explain what appears abnormal in the experiments of Mr. Young, where the proof was first fixed in the dark in hyposulphite of soda; then, after proper washing, developed in full light by gallic acid *cum* nitrate of silver.

This experiment succeeds only with albumen negatives, and after a good exposure. The preceding facts give a very simple explanation, as in these circumstances an argentic-albumen compound is produced, which the hyposulphite of soda does not remove, and upon which the developing agents cannot act.—*Bulletin de la Société Française de Photographie.*

A SHORT LESSON IN PHOTOGRAPHY.—No. 8.*

THE melainotype, after development and fixing, *may* appear far from satisfactory; the whole surface appears dim, indistinct, and covered as it were with a veil; there seems to be a metallic film, a thin and semi-transparent film, pervading the surface of the picture; in fact, we have a specimen of what is technically called a "foggy picture." This is not an uncommon phenomenon with a new bath—one newly prepared, and it is very likely to occur with every new bath if the nitrate of silver used in its preparation be genuine and neutral. With an old bath the evil in question is known to every photographer; there is, perhaps, not one who has not had the misfortune to complain that his pictures were fogged, that his bath was out of order, and that customers had to be sent away until the calamity in the bath had been rectified. Whenever this fogginess manifests itself, however, we fortunately know its remedy. The bath in such a case is either *alkaline* or *neutral*; the remedy is: to make it *slightly acid*. This remedy can be effected in three ways: either by adding a drop—sometimes even only half a drop—of acid to the bath, by adding tincture of iodine to the collodion, or to the bath. The result of my experience teaches me to make it an imperative duty never to *doctor* the bath, that is, never to introduce any extraneous chemicals, but those which enter unavoidably through the collodion. To filter the bath frequently is a benefit; to boil it in a glass retort or a matras is a benefit; for, by the first operation, it is freed from innumerable fine particles of undissolved salts of iodine, which are found in every bath after it has been used awhile; and, by the latter process, the alcohol and ether, that have been accumulated from the collodionized plates, are distilled off, and the solution of nitrate of silver is thereby concentrated—but *add neither acid nor alkali*. I admit that the addition of acid will correct fogginess, that acid is a sure remedy in most cases; but my belief is that the bath is thereby deteriorated, and will soon approach its end: that is, that a

* From *Humphrey's Journal*.

new bath will soon have to be substituted in its stead; but what is to be done? cry nearly all the photographers in a breath. The answer from a few scientific operators and from myself is: "Doctor your collodion."

Whenever fogginess presents itself on the surface of your collodion, add tincture of iodine to the collodion until it assumes a wine colour; now try a picture: an improvement will assuredly be the result; if the picture be not yet quite clear, add a few drops more of the tincture, until all fogginess has disappeared. By observing this plan, each collodion surface is *doctored*; for it carries upon it that which produces a liberation of nitric acid by chemical decomposition, and this liberation takes place at the right time, on the right place, and in the right quantity.

Tincture of iodine for photographic purposes is prepared by dissolving iodine in the *strongest* alcohol; you must be very careful not to use an inferior article of alcohol, because the water which it contains would injure the collodion by coagulating the pyroxyline.

The evil of fogginess having been corrected and remedied, let us now proceed and wash the picture after it has been properly developed and fixed. Inasmuch as we have two fixing solutions, namely—*hyposulphite of soda* and *cyanide of potassium*, it might be a pertinent question to know which is preferable for the melainotype. Photographers give a preference altogether to the latter solution; and why? Because of two properties: in the first place it acts quicker on the unsolarized iodides; secondly, it is a reducing agent, and acts as such on the silver film, producing a beautiful silvery white appearance in the high lights; in the negative this silvery whiteness is not required, and is thought by some to be injurious; so that hyposulphite of soda is considered the proper fixing solution by many distinguished operators for negative pictures.

After the melainotype is thoroughly washed from all traces of cyanide of potassium, it is dried, generally by the artificial heat from a spirit lamp (alcohol lamp). In this operation you must exercise great care lest you raise blisters on the japanned surface of the picture; for an undue heat on any point will, with several specimens of the iron plate, produce almost inevitably the evils alluded to. A small light properly managed, so that the heat is well diffused over the whole surface, by moving the posterior part of the plate gently over the flame, backwards and forwards, will dry the collodion surface without disrupting the japan from the iron.

As soon as the operation of drying is finished, the picture is ready to pass into the hands of an artist, in order to receive the touch of his magic pencil. Various little particles on the background, in the drapery and elsewhere, will soon disappear as he proceeds with his artistic improvement; parts, before gray and indefinite in character, assume shades distinct and agreeable; besides this, he works in a slight shade of colour on the cheeks, which communicates a life-like brilliancy to the picture, which before it did not possess; in fact, it gives a roundness to the features which before were flat and deathlike. Even the drapery itself may, at this stage, receive its natural tinting if desired; good taste, however, eschews much colour; a vulgar taste seeks the gratification of strong contrasts, and hence of high colours; for such a taste you will have to *gild* buttons, ear-rings, breast-pins, and watch-chains; for such you will have to *paste* on colour to obscure every other shade beneath; and for such, unfortunately, the artistic photographer has frequently to cast his pearls before swine; his bread, however, is the gain; and it is the part of a *business man*, at least, to sacrifice all preconceived notions to the desires of his customers.

When all colouring, gilding, and tenebriating of the hair with lamp-black are finished, the picture is flowed with the proper varnish, in the same way as the plate is flowed with collodion. The varnished surface may then be gently dried by the side of a small light artificially, or allowed to dry naturally by rearing the plate on the end, from which

the varnish flowed, in the corner of a pane of glass in the window.

The picture, after this operation, is ready for mounting in a case, or simply in a mat for transportation in a letter by the mail.

THE COPYRIGHT OF PHOTOGRAPHS.

CHARLES DANIELS a photographer, carrying on business at No. 1, Penton-place, Pentonville, was charged before Mr. Barker, at Clerkenwell, on Wednesday week, with selling a copy or colourable imitation of a photograph of Mr. Sothorn as Lord Dundreary, without the consent of Henry Hering, photographic artist, of 137, Regent-street, the proprietor of the subsisting copyright of such photograph, and knowing the said copy or imitation had been unlawfully made.

Mr. Brandt, barrister, instructed by Mr. Bowen May, of Russell-square, attended for the complainants; and Mr. Pook, solicitor, of Basinghall-street, for the defendant.

The defendant pleaded "Not Guilty."

Mr. Brandt, in opening the case, said that he was instructed by Mr. Bowen May in his capacity of solicitor for the protection of the photographic trade, and not in connection with the trade or profession of engravers. Mr. Hering had published portraits of Mr. Sothorn in ten different positions in his character of Lord Dundreary, and as soon as those portraits came out they met with an enormous sale. Shortly afterwards the piracies complained of appeared in windows in different parts of the town for sale at a much reduced price; and an inquiry being set on foot, two of the spurious portraits had been purchased at the shop of Messrs. Palmer and Sutton, in Tottenham-court-road; and that firm, on being applied to, gave the name of Mr. Daniels, the present defendant, as the person from whom they received the supply. On this information being given by Messrs. Palmer and Sutton, a letter was written to the defendant by Mr. Bowen May, in the following terms:—

67, Russell-square, Dec. 31, 1862.

"Sir,—I am instructed by Mr. Hering to take proceedings against you to recover compensation in damages for selling pirated copies of his photograph of Lord Dundreary. If you at once come forward, give up the name of the manufacturer—if you are not he—and undertake not to offend again, my client will be satisfied with the payment of a very small penalty. Your immediate attention is necessary."

Of this communication the defendant did not take the least notice. After an inspection had been made of the photographs at Palmer and Sutton's, Mr. Bowen May wrote the following letter, dated January 2, 1863:—

"I have satisfied myself that you did sell to Messrs. Palmer and Sutton the pirated photographs; and, unless you forthwith give up the name of the manufacturer, I must assume you are unable to do so, from the fact that you have the negatives and print yourself."

Still no reply was received, and hence the present summons was issued under the 6th section of the 26th and 27th Victoria, cap. 68, entitled "An Act for amending the laws relating to the copyright in works of art, and for the suppressing the commission of fraud in the production and sale of such works." The complainant having some doubts as to whether his productions might be pirated, had published on the face and back of them that they were copyright, and therefore the defendant could not plead ignorance of the fact.

Mr. Henry Hering, the complainant, was sworn and deposed that he had published many photographic likenesses. Among others he had published portraits of Mr. Sothorn in the character of "Lord Dundreary," in ten attitudes or positions. Two of the portraits now produced were his, and on them he had printed his name, with the words "Copyright secured," and on the back his address, "H. Hering, photographer, 137, Regent-street." These photographs he had registered in the proper manner at Stationers' Hall, and the certificates of registry he now produced. He would swear that the photographs now produced (the imitations) were "positives" obtained from "negatives" of his production, and which were included in the certificate of registration. He had never given any consent or authority to the defendant or any other person to copy or publish copies of the portrait or any other.

In his cross-examination by Mr. Pook, the witness stated that he had first obtained the consent of Mr. Sothorn to sit for his portrait at the latter end of July last, and the registration

was not effected until the 30th of August. He denied that he had sold any of the portraits until after the registration had been completed. He had not obtained any written, but merely a verbal permission from Mr. Sothorn to publish the portraits. There was not a single copy sold until several days after the portrait was registered; and of that he was certain; and after the permission was obtained he went on printing them and keeping them in stock until the registration was perfected.

By Mr. Brandt.—I would not even let Mrs. Sothorn have a copy until it was registered. (Loud laughter.)

Mr. George Bishop was next called, and proved that he was a member of the firm of Marion and Co., 23, Soho Square, who were wholesale agents for Mr. Hering, the complainant, and other photographers, and that he purchased the photograph produced (the pirated copy) at the shop of Messrs. Palmer and Sutton, in Tottenham-court-road, on the 29th December last. He paid 6d. each for the copies.

Joseph Kershaw, aged 17, deposed that he was an assistant in the service of Messrs. Palmer and Sutton, and that he remembered selling to the last witness the photograph (the piracy) now produced. The photograph was purchased by his employers from the defendant, Mr. Daniels, among others which were brought to his masters' establishment by the defendant's boy.

The witness was severely cross-examined by Mr. Pook, with a view to show that he could not swear to the identical portrait he had sold to Mr. Bishop being part and parcel of the lot supplied to his employers by the defendant, Mr. Daniels. He only knew it was purchased by the firm to which he belonged, by the fact that he saw the goods paid for by a lady in the shop. The first lot consisted of ten dozen, and the second of five dozen. The money was paid in his presence. Of the portraits thus supplied he could not swear that the identical portrait now produced formed part of either parcel. Of this he was sure—that all the portraits of Mr. Sothorn, as Lord Dundreary, which his master had in stock, came from the defendant in the parcels he had mentioned.

Mr. Bowen May was next called, and proved that he was the attorney for the complainant in this case, and that the letters which had been read had been written by him to the defendant. On a subsequent day the defendant had called upon him. On being shown the portrait in question, as well as one of Sir E. Bulwer Lytton (both of which had been purchased at Messrs. Palmer and Sutton's), he said that the former had been published by him. The latter he denied all knowledge of.

Mr. John James, clerk to Mr. Bowen May, corroborated this evidence.

Mr. Brandt then informed the Court that Mr. Mayall and other eminent photographers were present, who could prove that the imitative portrait must have been taken from the original of the complainant.

Mr. Pook, for the defendant, said it had not been proved that the defendant had any knowledge that a copyright had been registered, or that he had any notice that a copyright existed. The same question had been raised elsewhere in the case of "Gambart v. Powell," in which Mr. Corrie, the magistrate, had dismissed the summons.

Mr. Brandt.—That was a summons issued under the provisions of another Act of Parliament—viz., the 17th of George III., and had nothing whatever to do with the statute now under consideration.

Mr. Pook resumed, and said, though that might be so, there had since been a decision in the Court of Common Pleas in which Mr. Justice Willes had given judgment against a photographer in a similar case, and in that instance a motion for a new trial, moved for by Mr. Coleridge, was now pending. He took two points on behalf of his client, the defendant, and the first was that there had been no proof of any agreement in writing by Mr. Sothorn for the publication of his portrait; and secondly, that if any such agreement had existed, and the copyright had been registered, it had not been brought to the knowledge of the defendant, as was contemplated by the Act of Parliament under which this action had been brought.

Mr. Barker said he was quite satisfied with the evidence before him that the defendant had been guilty of the wrongful act imputed to him under the summons and proved in evidence; and in order to give him, if he would be so advised, an opportunity of appealing against his (Mr. Barker's) decision, he should remit the penalty to the sum of £3 0s. 6d., with power of appeal, and award £2 2s. for costs.

The defendant next pleaded "Not Guilty" to a summons issued at the instance of Mr. John Edwin Mayall, photographer,

of Regent Street, for the pirating and publishing of a photograph of Sir E. Bulwer Lytton, M.P.

Mr. Mayall deposed that Sir E. Bulwer Lytton had sat to him for his portrait at the latter end of July last. He registered the portrait on the 21st of August, and of that registration he now produced a certificate. The three copies or imitations now produced were piracies of that copyright. There had been an attempt to alter the incidents of the picture by an alteration of the curtain in the background, the table at which the figure stood, and the carpet, but these were changes which any photographer with a pencil and colour could accomplish; still he was convinced that the portrait was a piracy of his original photograph. The copies were a disgrace to any man pretending to a knowledge of photography.

In his cross-examination by Mr. Pook, the witness said he had the written permission of Sir E. Bulwer Lytton to publish the portrait in question, but he did not even allow the honourable baronet himself to have a copy until he had registered it.

Evidence was then given as in the previous case.

Mr. Barker said that this case was as clearly proved as the former one, and his decision must be the same—namely, £3 0s. 6d., with the same power of appeal, and £2 2s. costs.

At a subsequent sitting, Mr. Barker was informed that Mr. Pook, the solicitor for Mr. Daniels, who was convicted at this court, on Wednesday last, for selling copies of photographs of Mr. Sothorn as Lord Dundreary, and of Sir Edward Bulwer Lytton, Bart., M.P., had withdrawn the appeals he had given notice of, and that the cases were at an end, as the fines had been paid into court. Mr. May had been asked to accept of a mitigated penalty; but he now could not do so, as he had, on behalf of his clients, and before any expense had been incurred, explained to Daniels that he had rendered himself liable to heavy damages for printing the above portraits, and offered to accept a few shillings' penalty, merely to impress the fact on Daniels' memory. This liberal offer had been refused, and further expenses had been incurred by notice of appeal having been given. The money which had been paid into court, amounting to £10 5s., would hardly pay the expenses that had been incurred; and, under the circumstances, Mr. May could not think of asking the magistrate now to mitigate the penalty. From what had come to the knowledge of Mr. May, there could be no doubt that the money did not wholly come out of the pocket of Daniels, but was found by an association.

Mr. Barker said that he should only have inflicted a nominal fine had not the defendant asked that such an amount should be fixed as to enable him to appeal. As he had not gone on with the appeal, and as the money had been paid into court, he should at once give an order for the amount to be handed over to Mr. May's clerk.

Proceedings of Societies.

NORTH LONDON PHOTOGRAPHIC ASSOCIATION.

THE usual monthly meeting was held in Myddelton Hall, Islington, on the evening of January 21st. Mr. W. Hislop in the chair.

The minutes of a preceding meeting having been read and confirmed, the following gentlemen were elected members of the Society: Messrs. P. E. Coffey, E. G. Wood, J. R. Thompson, T. R. Williams, J. Martin, and Mr. Snoad.

A number of new stereoscopic slides, instantaneous and otherwise, by Mr. Wilson, of Aberdeen, were exhibited by Mr. G. Wharton Simpson; and the three reproductions by Mr. Annan, distributed this year to the Glasgow Art Union, were exhibited by Mr. Dallmeyer.

Mr. W. W. King then proceeded to read a paper entitled "A Photographic Trip in Norway," by the Rev. Arthur Cotton (see p. 53). A number of very interesting views, taken with Dallmeyer's No. 8 triple, were exhibited as illustrating the paper. One of the best photographs and most pleasing pictures was stated to have been taken between 8 and 9 o'clock at night. After some conversation about the pictures, a vote of thanks to Mr. King was passed.

Some conversation on Mr. Annan's reproductions, which were much admired, followed.

Mr. SHADBOLT produced some prints which were exhibited as specimens of toning, regarding which a manufacturer of albumenized paper wished to obtain an opinion as to which

was best for portraiture and which for landscape, as a guide to him in preparing the paper. As no information as to the method of producing the respective tones was forthcoming, no expression of opinion as to their value was elicited.

Mr. DAWSON, referring to the specimens of Mr. Wilson's stereographs before the meeting, said they were very beautiful, as all his pictures were; but many of them displayed a great amount of curvature in the lines, showing they had been taken with a single lens. This was a serious defect in architectural work, and it was somewhat strange that such a lens should be used for such a purpose, seeing that others were now to be obtained.

Mr. HILL said that Mr. Wilson did use other lenses, as many of the pictures he had in the Exhibition were with the triple lens.

Mr. DAWSON was referring to the pictures now before them.

Mr. DALLMEYER remarked that Mr. Wilson had been using a single lens, which he had recently made for him, for instantaneous stereoscopic work; its peculiarity being, that it might be worked with a very large aperture. In the ordinary stereoscope, with a lens of six inches focus, in which these views were intended to be inspected, the slight curvature of lines would be corrected, as it had a tendency to produce the opposite kind of distortion to that exhibited in these pictures, and thus, in the stereoscope, the lines would appear straight. As for views not intended for the stereoscope, the time had come when photographers would not tolerate views with curved lines; and, for larger pictures, Mr. Wilson used the triple achromatic lens; and he had just been making him a camera with swing back, which, permitting the plane of delineation and the object always to be parallel, prevented convergence of the lines when it was necessary to tilt the camera. The triple lens then gave absolute freedom from distortion in architecture; and, for landscape purposes, he thought he only need to refer to some of the pictures of Col. Stuart Wortley to show how pre-eminently fitted it is for giving brilliant results in that kind of work. For stereoscopic interiors he thought a double combination was best, and he might refer, as examples, to the stereoscopic pictures of the interior of the International Exhibition, by the Stereoscopic Company, which were taken with his No. 1 B.

Mr. DAWSON, referred to a recent visit he had made to Mr. Wilson, when he saw his various lenses, and some very beautiful pictures. Some of his lenses only cost a few shillings.

After some further conversation, in which the tones of the prints exhibited by Mr. Shadbolt were again canvassed, he said he believed the difference in tone was due simply to the different proportion of chloride and albumen used, the same salt being used in all. In some there was a slight pink tint in the whites.

Mr. SEELEY thought that no rule could be laid down for uniformity of tone. The sentiment of the subject should be considered, and the kind of negative. A soft negative required the most brilliant white paper, whilst a hard one was sometimes improved by a little degradation of the whites.

Mr. SYDNEY SMYTH exhibited some instantaneous stereographs, taken at Plymouth, which were much admired. In answer to questions, he explained that they were produced with collodion made by himself, containing two grains of bromide to each ounce, and equal portions, of iodide of cadmium and ammonium. The lens was one of Shepherd's card portrait lenses, of 6½ inches focus, with a stop of about ⅙ of an inch.

Mr. DAWSON said the difference between these pictures and Mr. Wilson's, consisted in the fact, that, whilst Mr. Smyth's had manifestly been taken with an enormous flood of light poured through a portrait lens, Mr. Wilson's were taken with a single lens and small aperture. He took care to have his chemicals in such sensitive condition, that he got the instantaneous effects with these appliances that others got with large aperture and portrait lenses, and thus the general definition, and especially the distances, in his were superior.

Mr. SEELEY asked if it were not generally understood, that a single lens with small aperture was equal to a compound lens with large aperture, owing to the number of reflecting surfaces in the latter, all decreasing light.

Mr. DALLMEYER said something was undoubtedly lost by the number of reflecting surfaces, but much less than was often represented or fancied. The proportion of loss calculated by Professor Petzval for central pencils was only one-thirtieth part of the whole. It was not possible to use a single so as to work as quick as a double combination. Knowing that the single lens gave greater depth of focus than the portrait com-

bination, he had taken the new single lens he had made for Mr. Wilson to Mr. Williams to try. They tested it with the No. 1 B, using with the latter a stop of 1¼ inch, and with the other a stop of ⅙ inch. The result was that the single lens gave a bare positive, whilst in the same time the double lens gave an over-exposed negative. Perhaps it might be well to remember that in the majority of Mr. Wilson's subjects a quasi-instantaneous exposure was admissible, and where perfect instantaneousity was imperative the double combination should be used. Mr. Breese, who used his new stereo compound lens of 3½ inches back focus, or 4¼ inches equivalent focus, told him that he was able to take the moon quite instantaneously with it. Now Mr. De la Rue has always found it necessary to give at least five seconds, and it followed from the difficulty of following the moon's course that much less perfect results could be obtained by a prolonged than an instantaneous exposure.

After some further conversation, the proceedings terminated.

The International Exhibition.

REPORT OF THE JURY ON PHOTOGRAPHY AND PHOTOGRAPHIC APPARATUS,*

THE APPLICATIONS OF PHOTOGRAPHY.

THE applications of photography are already such as mark a high destiny for the art, and are a source of proud gratification to those who have been associated with its history and progress.

In portraiture, its most widely-extended and popular application, its value, in contributing to individual and social happiness, by placing within reach of the lowliest, as well as the highest, the treasured mementos of absent friends, scarcely needs affirming. The extent to which the class of portraits known as *cartes de visite* have been circulated, is almost beyond belief.

Its aid and connection with various sciences, as a faithful recorder, has of late years received ample recognition and illustration. In the magnetic and meteorological department of the Royal Observatory at Greenwich, photography is in daily use, and proves of inestimable value as a registrar of the magnetic and atmospheric variations. To the invention of Mr. C. Brooke, F.R.S., and the subsequent adaptation of the late Mr. Welch, the public are indebted for many useful applications of photography to the registration of natural phenomena. Under the able superintendence of Mr. Glaisher, every perturbation of the magnet during each of the twenty-four hours is self-registered by the aid of photography. The thermometer and barometer are made, by its aid, to record their own variations. Similar registrations in different parts of the world afford facilities for accurate comparison, and contributions of the utmost importance are thus secured towards the systemizing, and establishing, upon certain data, meteorological science.

The contributions of photography to pictorial art have been many and important during the last ten years. Perhaps the most interesting of these have been in the department of instantaneous photography, by which the evanescent and changing aspects of nature are seized and rendered permanent ere they have had time to change. Those fleeting and ever-charming atmospheric effects which, "ere a man can say, behold the jaws of darkness swallow," or which are—

"Just like a snow-flake on the river,
A moment bright, then gone for ever,"

are depicted with the rapidity of light—preserved for future contemplation.

The advancement in the chemical branches of the art; the improvement in optical appliances, and the increased skill in manipulation, have enabled photographers to secure various phases of the ocean in calm and storm, and under all conditions of light and sky, and atmospheric effect. Crowded thoroughfares filled with rapidly-moving figures and vehicles are accurately rendered, the uplifted foot caught and depicted in mid-air, never to fall.

Vesuvius in eruption, with its rolling volumes of smoke, is caught and fixed upon the tablet of the photographer. Apart from the pleasure obtained from the examination of such pictures for their own sake, their value to the painter, in reducing his labour and increasing the truthfulness of his results, is of very great importance.

The small images, which are usually obtained by instantaneous processes, are, moreover, capable of amplification by such appliances as the solar camera, and other means which have been recently brought to a high state of perfection. Photography itself has also aimed at emulating the productions of the painter, as well as aiding him by supplying him with studies; and the composition groups of Rejlander, Robison, and others, give much hope of successful results in this direction.

The production of natural colours by means of photography remains to be accomplished; but the labours of MM. Becquerel and Niepce de St. Victor afford hope that such an end is not beyond the range of possibility. Within the last year, the latter gentleman has succeeded, not only in producing colours, as in an original, but in preserving them for a few hours. The fact, once accomplished, establishes the possibility, and the means only require to be defined and verified.

A record of the progress of photography, as illustrated by all its applications, would far more than fill the space allotted in this Report. Suffice it to say, that there is scarcely a branch of art, of science, of economics, or, indeed, of human interest in its widest amplification, in which the applications of this art have not been made useful.

In addition to those applications of which we have spoken, it may be briefly added, that photography has, by the rapidity and uncompromising truth of its delineations, aided the psychologist in his studies of the physiognomy of mental disease or abnormal emotion, as the portraits which have been publicly exhibited strikingly illustrate.

It has aided the study of medical science by its truthful representation in

* Continued from p. 46.

morbid anatomy of malformation and disease generally, and by its record of the progress of cases and illustrations of surgical treatment.

As an aid to ethnological science, no mode of delineation can compare with it. Its unerring truthfulness has been found of unsurpassed value to the student of every branch of natural history, as is shown in the productions of Comte de Montizon, and others.

In giving a permanent form to the enlarged images of the microscope, it has added a truth and value to the productions of the micrographer which could not otherwise possess.

The archaeologist and antiquary, the virtuoso and historian, have gladly acknowledged its value, and sought its aid. With the architect and engineer it supersees, and far surpasses in many cases the drawings made by hand. For them it records unerringly the progress of works from which the directing mind may be thousands of miles distant.

It enters the court of justice, and becomes the unchallengeable reproducer of documents; or, pursuing the criminal, it silently, but indisputably, identifies him in a land where he is unknown.

For the manufacturer it depicts his designs, patterns, or workmanship with facility and truth not to be equalled, illustrations of which are to be found in every part of the present display of the world's industry.

And lastly, more ambitious still, as if the globe were too narrow a sphere for its resources, it travels into space, seeking and taking records of the phases of other worlds, and of that great body the sun, to whose subtle and "archchick" gift it owes its power and life.

It is satisfactory also to know that the status of photography is still further recognized by an Act of Parliament, passed last session, securing copyright in photographs, hitherto not given by law.

(To be continued.)

Correspondence.

FOREIGN SCIENCE.

[FROM OUR SPECIAL CORRESPONDENT.]

Paris, 28th January, 1863.

You will remember that the Academy of Sciences proposed last year, as the subject of competition for the Bordin prize, the following important photographic question:—

To determine by experiment the causes capable of influencing the differences of position between the optical and the photogenic foci.

Several elaborate *Mémoires* have been addressed to the Academy, two of which obtained prizes. From M. Fizeau's Report I extract the following passages.

"A short time after the announcement of the discovery of Niepce and Daguerre, when so many persons ardently devoted themselves to the production of pictures drawn by light, observers attentive to giving the greatest possible sharpness to the images soon remarked a singular fact, viz.: that the pictures obtained were not generally satisfactory, when the plate was placed exactly in the optical focus of the lens, that is to say, in the plane where the eye perceived the image of an object with the greatest distinctness, while the proofs presented a much superior sharpness when the plate was placed at a certain distance from this optical focus, in a distinct place which has been designated the *chemical* or *photogenic* focus."

Experience has shown that the difference of position of these two foci may be observed with the various sensitive films employed at the present day in photography, but that it is generally very variable, according to the quality of the objective, and also with the size of the images obtained by means of the same objective. In certain instances the state of the atmosphere also exercises a marked influence which, however, is but slightly apparent in ordinary circumstances, and may be overlooked.

The first *Mémoire* we now report upon bears the device, "Theory is the Explanation of Facts by Real Causes."

The author commences by establishing the fundamental fact of the difference of position between the optical and chemical foci by means of experiments, the specimens of which accompanying the *Mémoire* add to the clearness of the demonstration. The fact being well established, the author, in seeking the cause, analyses with much sagacity the complex circumstances which result from the achromatism of the lenses; to this end he imagines twenty-one different achromatic systems, in which the principal rays of the solar spectrum are successively united in pairs at the same focus, and in each of these cases he determines by a close calculation the relative foci peculiar to each of the other rays.

In the second part of the *Mémoire*, still more developed than the first, the author endeavours to give a practical character to his work by considering the following problem:—Given an objective, for which we have determined, by experiment, the difference in position of the two foci, in the instance where the image is of the same size as the object; to determine beforehand the distance of the two foci (or what the author calls the *chemical correction*) for any sized image, or in other terms, for any distance from the object.

The author arrives at a very simple formula, which permits of our calculating the photogenic distance of the optical focus of any objective system whatever, for various sized images, provided that we have determined, by experiment, a certain constant quantity peculiar to each objective, or the distance of the two foci in the case where the image and the object are both of the same size.

This *Mémoire* concludes with numerical tables, intended to give, in all circumstances which may present themselves in practice, the value of the *chemical correction*, and of the slight displacement which must be given to each plate, beyond or nearer to the optical focus, to obtain the greatest possible sharpness in the picture. These tables have been verified by M. Bertsch, the eminent photographer.

The author of this *Mémoire* is M. Felix Reynard, of Saint Martin, near Grenoble. The Academy has awarded him a gold medal of the value of two thousand francs.

The second *Mémoire* is written in the German language. Its device is:—*Es irrt der Mensch so lang er strebt.*

The work is in two parts; the first consists principally of the principles of optics.

In the second part, which includes no less than thirty folio pages of numerical calculations, the author, with a zeal and perseverance worthy of all praise, devoted himself to a detailed analysis of the properties of various achromatic objectives composed either of one or many systems of lenses; and in taking into account in these calculations the thickness and mutual distances of the lenses, he determines separately the foci, or points of meeting, of nine species of different rays, at nearly equal spaces amid the various colours which compose the solar spectrum from the ray B to the ray H.

From these researches the author draws practical conclusions adapted to guide opticians in the construction of objectives intended for photography, by indicating certain relations between the distance which separates the optical from the chemical focus for various objectives, and the tint of the coloured fringes which border the images when the eye perceives them in the optical focus.

The author of this *Mémoire* is Herr Carl Miersch, of Dresden, Saxony. The Academy, in recognition of the merits of this work, awarded the author a gold medal of the value of a thousand francs.

At the last meeting of our Photographic Society, the committee reported that, considering the prosperous condition of the Society, they thought it their duty in future to encourage and reward the interesting works and important inventions that might be communicated to it. They propose to establish an annual distribution of medals to be awarded as honorific rather than as pecuniary recompenses, for the most important presentations made to the Society, beside the competitions opened for certain determinate prizes.

The President remarked that it was unnecessary to dwell upon the evident advantages of this proposal, which, while rendering an act of justice, would excite and surely attract to the French Photographic Society the studies and researches of all those, foreigners as well as natives, who could in any department of the art effect an improvement and aid the progress of photography. But, in order to secure all the advantages of the proposal, it would be necessary that the programme should be carefully studied, and its application well regulated.

The Secretary also announced that the committee, in order to impart additional interest to the meetings of the Society,

proposed to exhibit various experimental demonstrations upon the scientific questions connected with photographic phenomena. M. Edmund Becquerel, at the request of the committee, will commence a series of demonstrations at the February meeting of the Society.

It was also stated that the project of connecting a photographic laboratory with the *locale* occupied by the Society had for a long time engaged the serious attention of the committee, but that certain practical difficulties existed which prevented the committee from carrying out this desirable object. When their present lease expired would be the time to select such a locality as would admit of this project being carried into operation.

The Secretary observed to the meeting that the Society had now been in existence eight years, and had prospered far beyond all expectation; and that this prosperity was doubtless owing to the prudence with which its affairs had been conducted. It may not be superfluous to remind English artists that our Photographic Exhibition opens on the 1st of May, and that we hope to see it adorned with some of those charming works the fame of which has reached us, and which form the frequent topic of photographic conversation.

WHOLESALE PIRACIES.

OBSERVING the letter of "Fair Play" in your last week's journal, on "New Mode of Piracy," I think it well to inform you that I have the opinion of an eminent member of the bar, well versed in copyright law, that *this* system of copying is illegal; also, that there is no doubt but a verdict would be given against photographers and dealers for selling copies of *cartes de visite* which have been published *prior*, although registered *since* the passing of the Act 25 and 26 Victoria, sec. 6.

I believe it is not generally known the enormous extent to which piracy in photography is carried on. Having received information from various correspondents that copies of my portrait of a person of considerable celebrity were being sold to a great extent throughout the kingdom, I took the trouble to discover the delinquent. At one wholesale dealer's I obtained his list of no less than 500 various portraits, at a second 559, at a third nearly 700; the stock in the warehouse of the latter must consist of at least 100,000 copies, therefore we may conclude that as many have been palmed on the public as genuine, which of course very seriously injures the reputation and interest of the original photographers.

On taking legal steps against one of these unprincipled dealers, proceedings were stayed in consideration of certain damages and costs, and a discharge to that date given from any further penalty for having sold pirated copies; also, to nearly thirty of his customers, amongst whom were to be found the names of many of the largest and wealthiest silkmongers and drapers in the city and provinces; but it is believed these latter gentlemen were ignorant that they were being supplied with spurious goods. The photographer in one case (who, by the by, claims relationship with royal blood!) also had to pay heavy damages and costs, and was bound over to respect the law for the future. In the two cases which appeared in the *Times*, at the Clerkenwell Police Court, on the 22nd inst., before Mr. Barker, the defendant was convicted, and a penalty imposed of £3 0s. 6d. and costs, £2 2s., in each case. Although nothing could have been clearer than the proofs in each case, defendant's solicitor recommended his client to appeal against the decisions of the magistrate. Wisely, however, the penalties have since been paid.

Were photographers to devote a little time and trouble to their own interests in this matter, they would soon put a stop to piracy. The course to be taken is simple: the proprietor should send some one in his employ to purchase a copy exposed for sale; let him write on the back the name and address of the vendor, time and date, and post it to the

solicitor, with instructions to do the needful, and within a week or ten days the police magistrate will convict the offender. I hear that there are no less than 18 cases now in the hands of the solicitor, several of which will be brought before the provincial magistrates. It is to be hoped that every possible information respecting illegal copying, will be given by respectable dealers to the solicitor of the Association.—Your obedient servant,
A PHOTOGRAPHER.

[We strongly commend photographers to adopt the advice of our correspondent. Prompt and vigorous measures now, will, we hope, speedily put a stop to the piracies which have so long degraded the art, and defrauded able and respectable photographers. We intend to give the fullest publicity to every case of which we obtain information. See page 55.—Ed.]

Photographic Notes and Queries.

OBTAINING CLOUDS IN LANDSCAPES.

SIR,—The use of the flap-shutter, for varying the exposure of foreground and sky, as mentioned by Mr. W. H. Warner, in No. 227 of the *News*, although not new, is perhaps the most simple mode of attaining that object—at least, in cases where the straight edge of the shutter does not preclude its adoption. May I be permitted to suggest a mode of working it which I have found advantageous, in use with the binocular box stereoscopic camera, which I designed about three years since, and which I think will be found free from the objections which would apply to the plan of marking with a pencil line, as described by your correspondent. A small index is attached to the axis on which the shutter turns, and is fixed by a movement of the finger of the same hand by which the flap is held, while the necessary angle is ascertained by looking at the ground glass. The details will immediately suggest themselves to any mechanic. I think, at the same time, that the use of the flap-shutter, in the ordinary form, must always be extremely limited, and thus a means of adapting the line of division to that of the actual view will be much more valuable, and this is not difficult of attainment.—Yours truly,
C. W. SMART.

BOOK PACKETS AND NEWSPAPERS.—The following regulations will affect the postage of photographs:—On the 2nd of February the following alterations will take effect in the rules affecting book packets and newspapers:—1. Book packets sent through the post between places in the United Kingdom, or between the United Kingdom and any of the colonies, which may have been posted either wholly unpaid or paid less than a single rate of book postage, will be forwarded to their destination charged, not as at present with the letter postage, but only with a postage which, together with any stamps which they may bear, will be equal to double the book postage which should have been prepaid. 2. No prints or printed matter will be allowed to be sent in book packets between places in the United Kingdom, or between the United Kingdom and any of the colonies, except such as may be printed on paper, parchment, or vellum. 3. Any newspaper bearing the impressed or newspaper stamp, posted for transmission between places in the United Kingdom, which may be found to have any writing or marks (though it be only a previous address to another person, and that cancelled) either upon the newspaper itself or upon its cover, other than the name and address of the person to whom it is sent, or anything printed upon its cover, except the name or title of the newspaper and the name and address of the publisher, newsvendor, or agent, by whom it is sent, will be charged, not as now with the double letter postage according to its weight, but only with a postage of 2d., being the double postage for a letter not exceeding half an ounce in weight. This charge is to be made for each newspaper written upon or marked, whether sent singly or in a packet of newspapers. 4. A newspaper for any place abroad, which may be found to infringe the rules in the manner described in paragraph 3, will not be forwarded, but will be sent to the returned letter branch. 5. A newspaper received as such from abroad, in regard to which there has been a similar violation of the rules, will be charged, in addition to any postage which may be chargeable upon it as a newspaper, with the postage payable on a single letter from the same country.

Talk in the Studio.

THE RECENT ROBBERY OF LENSES AT THE CRYSTAL PALACE.—Our readers who have already read the particulars of this case, as heard before the sitting magistrate at Lambeth, would notice two advertisements in our last; from Messrs. Negretti and Zambra, offering ten pounds reward for any information regarding the stolen lenses, and another offering two hundred pounds reward from Mr. Restal for similar information. As we are desirous of aiding the cause of justice, and the credit of photography, we wish to call the attention of our readers to these announcements, and to suggest that if the slightest information bearing on the subject be in the possession of our readers, it should be forwarded without delay both to Mr. Restal, the accused, and Messrs. Negretti and Zambra, justice demanding that both parties, in such a case, should be put in possession of every particular relating to it. It will be observed that any one who has, in ignorance, purchased any of the lenses, will not be deprived of them, Messrs. Negretti and Zambra being more anxious to find the real culprit, than to recover their lenses.

OPTICAL ILLUSIONS AT THE POLYTECHNIC.—Our readers who have opportunity will do well to hear Mr. Pepper's "Strange Lecture" at the Polytechnic Institution, which is chiefly devoted to the explanation and illustration of optical illusions, and incidentally contains many interesting illustrations of the nature and properties of light. The great feature of the lecture is the introduction of certain "ghosts," which, in vividness and reality, exceed anything before produced by optical illusions. The exact nature of the appliances is not explained, but there appears to be little doubt that the images are projected by the aid of a concave mirror. How the intensity of illumination necessary is managed is the puzzle, as the spectro appears at times more solid, real, and vivid than the real figure of a man which passes through the spectral images. We can conceive that photographing a ghost would become tolerably easy in this case.

To Correspondents.

- MR. SKAIFE'S PISTOLGRAPH.**—The words "Illustrated Guide, 2nd edition," were left out in the advertisement of Mr. Skaife's Ten Guinea Pistolgraph. This book can be obtained on receipt of 13 stamps, by applying at 32, Sussex Street, Regent's Park.
- NON-ACTIVE GLASS.**—Our report has been requested on several samples of glass. John Martin sends a specimen of brown pot metal, which we have so constantly had occasion to warn our readers against, as permitting considerable quantities of actinic light to pass through. J. W. sends three samples: No. 1 is similar to the above, but much lighter, and therefore even less safe. Nos. 2 and 3 are silver flashed glass. The former is very light, and in the spectroscopie allows many actinic rays, especially about the blue and violet, to pass. No. 3 is perfectly opaque to all photographic rays. EXCELSIOR sends two specimens: No. 1, a piece of the above-named brown pot metal, and No. 2, a piece of good orange silver flashed glass, identical in colour and properties with J. W.'s No. 3. The sample sent by J. B. is of similar silver flashed glass, which is perfectly trustworthy for the window of a dark room.
- PERPLEXITY.**—For glass positives it will be desirable to add a little nitric acid to the bath after treating with carbonate of soda. Or the same result, that is, clean shadows, may sometimes be obtained by adding tincture of iodine to the collodion, until it is the colour of a brown sherry. Regarding the works you name, No. 1 is out of print, and No. 2 is out of date.
- L. L. H.**—You will find much information on the application of photographic lenses to the purposes of the magic lantern in our back volumes. We may especially name page 53, Vol. v., or No. 126. See Mr. Highley's paper on the Magic Lantern and Photography.
- II. KENT.**—The method referred to is recommended by Mr. Maxwell Lyte; we have not tried it ourselves. When you add carbonate of soda to an acid solution at any time, be careful how you cork it up, as, unless the carbonic acid gas liberated can escape, an explosion such as you describe may easily follow. If you adopt the same method again, mix the carbonate of soda and phosphate of soda in a little water, and then pour it into the discoloured silver bath in an open vessel, stirring it meanwhile with a glass rod. We generally use kaolin to decolorise a bath.
- GARIBALDI.**—We cannot with propriety undertake to say which is the best house for obtaining any kind of photographic material; but in the articles you mention, silver and gold, the prices are generally uniform. It is impossible to say where they are kept purest.
- KRUGER.**—Your lens is scarcely quite equal to the production of standing card portraits, and you use too much front light, which gives flatness to the features.
- II. B.**—To obtain a biting surface in glass positives, upon which dry colour will readily adhere, a suitable varnish should be used. The alabastine varnish sold by Squire and Co., or the positive colouring varnish, sold by Newman, will answer the purpose. Colour first on the film, then varnish, and then again apply the dry colours. Should you not be able to obtain the varnish referred to, you may use a coating of turpentine after colouring on the film. This must be thoroughly dry before applying the colour,

and you will find it then adhere without difficulty. Nevertheless we do not like the use of the turpentine.

- II. R.**—Mr. England informed us that he had kept tannin and honey plates some months without serious deterioration. They should, however, be developed as soon after exposure as possible—that is, within a day or two. There is some uncertainty and discrepancy of experience on this subject. 2. The best mode of keeping dry plates is that which will most effectually protect them, not only from the light, but from moisture and atmospheric influences. If packed up in the fashion of Dr. Hill Norris's plates, they should, like his, be made air-tight. 3. Mr. Robinson has given the "May Queen" negative to a committee for the relief of Lancashire. We cannot tell you at present where prints may be had, nor the price. The negative went into the charge of Mr. Delamotte. 4. We prefer camera printing, with wet collodion, for transparencies. If you prefer printing by super-position, use tannin plates.
- F. L. G. K., AN OPERATOR, AN ASSISTANT OPERATOR, A PHOTOGRAPHIC PRINTER, and some others.**—We believe it is now in contemplation to open the Exhibition in the evenings the last fortnight of the season. See our remarks in this week's critique.
- AN AMATEUR.**—We do not remember, at this moment, a description of a changing box sufficiently full to enable you to make one; but they are to be had of most camera makers, and dealers in apparatus. We remember to have seen them in the establishments of Bland and Co., Mr. Hughes, and Mr. Meagher, and are, doubtless, kept by others. We are uncertain of the price. 2. Our own method of coating plates with the tannin solution is to pour on the plate sufficient to cover it; let it rest a minute or two on a levelling stand, whilst we attend to another plate; then pour the first solution off and coat again, and allow the plate to drain. We have no doubt that Mr. Sutton's plan will answer very well.
- JOHN MARTIN.**—Report on your glass in a paragraph above. 2. The electric light is the most actinic artificial light which has been applied to photographic purposes; but none has yet been successfully, or generally, applied commercially. 3. The plan described is scarcely suitable for the manufacture of oxygen on a small scale. 4. Three parts of chlorate of potash, and one of oxide of manganese, are good proportions for the manufacture of oxygen. 5. About four cubic feet of oxygen, and the same quantity of carburetted hydrogen will be consumed in an hour.
- A. B. C.**—Moule's night light is chiefly used for producing glass positives, and we have seen some pretty good ones so produced. Of course there is some little difficulty in obtaining sufficient light on the sitter without dazzling the eyes. We cannot tell you whether it is much used or not. 2. Polysulphide of potassium, or liver of sulphur, should be used for precipitating the silver from the residues of the sink. If you do a large business it will be quite worth while to save such residues.
- JOHN HAWKE.**—We are obliged by the charming cards, and also by the satisfactory information as to lens and collodion. We shall "make a note of it."
- D. M. A.** sends us, amongst various hints which we shall note and remember, a suggestion for the use of a solution of iron in place of tannin for dried plates. He states some experiments lead him to think that it would be successful. We fear it would be somewhat unmanageable, and that the plates would not keep well. It will be important to remove all free nitrate.
- E. L. LOCKE.**—Methods of dissolving silk to use instead of collodion have before been suggested, but have not come into practical use. By using proper care in the manufacture of collodion it is quite possible to obtain a very adherent and strong film.
- R. S. S.**—There is unquestionably a want of force about the standing figures, but whether it is due to having too much light stopped overhead we cannot with certainty say. There appears to be too much diffused light and too little direct light. The light wants concentrating so as to reach the sitter more directly from one source, and thus produce more definitely marked lights and shadows. Five or six feet opaque overhead, with a little more semi-opaque may probably answer very well. The standing figures appear over-exposed, and that will destroy contrast, however well lighted the figure may be.
- A. B.**—We will write shortly.
- COLOMBO.**—We do not know of any efficient means of restoring faded prints. Immersing them in a solution of chloride of gold has been suggested, but we have not tried it. Those which went down in the *Colombo* have been submitted to so many agencies which would act on silver prints that it is difficult to trace the cause of the discolouration and fading. When warmed they smell strongly of sulphur.
- G. R.**—For copying oil-paintings use a freely bromized collodion. Then expose for the darkest or most non-actinic parts, leaving the lights to take care of themselves. You will not lose detail in this way. Mr. Thurston Thompson, who has produced some of the finest copies of paintings ever issued, uses half as much bromide as iodide.
- S. JONES.**—We are not certain that we decipher this correspondent's signature, who enquires how long the acetate of soda and gold bath may be used. There is no especial limit but the bath becoming inert or exhausted; but it is well to use a little at a time and not use it very frequently, as it becomes of an uncertain strength and renders its time of working irregular. Slow toning may depend upon an inert or exhausted condition of the bath, upon cold weather, the quality of the paper, &c.; give paper, highly albumenized, toning more slowly than others. You may safely tone twenty card prints in one ounce of hypo, dissolved in five or six of water. A toning bath of hypo and gold which has been in use for six months is altogether unsafe, and the prints are not likely to stand. We do not require any fee for our advice in this column, it is always freely at the service of our readers.
- W. FOX.**—Thank you for your hints, of which we shall make a note. Articles on "Art-Photography and its Critics," on "Harrison's New Globe Lenses," "Scientific Gossip," and a variety of others are compelled to stand over for lack of space.
- AMATEUR, DRY PLATE, ALEC. ARNSTEIN,** and several other correspondents in our next.

Photographs Registered During the Past Week.

JOHN BEATTIE, 25, Triangle, Bristol,
Three-quarter portrait of Rev. David Thomas.

THE PHOTOGRAPHIC NEWS.

VOL. VII. No. 231.—February 6, 1863.

CONTENTS.

	PAGE		PAGE
Art-Photography and its Critics	61	The Application of Photography to the Magic Lantern Educationally Considered. By Samuel Highley, F.G.S., F.C.S. ...	68
Artistic Copyright	62	Proceedings of Societies	69
Photographic Exhibition—Award of Prizes	63	Correspondence. — Nature and Constitution of the Finished Negative	71
Silver in the Whites of Albumenized Prints. By John Spiller...	63	Photographic Notes and Queries	71
Printing Difficulties. By a Photographer's Assistant	64	Talk in the Studio	72
The Advantage of a Strong Nitrate of Silver Bath for Sensitizing Albumenized Paper, &c.	65	To Correspondents.....	72
On Some of the Uses and Abuses of Photography. By Thomas Sutton, Esq., B.A.	65	Photographs Registered during the Week	72

ART-PHOTOGRAPHY AND ITS CRITICS.

THE majority of the art-critics have shown an amusing agreement in condemning art-photography, as displayed in the Photographic Exhibition this year. Critics do not often endorse each other, but "when they do agree, their unanimity is wonderful." It is true they vary as to the precise grounds of their condemnation, but they agree in attacking the art wherever it seems most likely to innovate upon what they conceive to be the legitimate province of the artist, wherever it seems likely to produce pictures, or something more than studies, which "may be taken as memoranda for the use of artists." It is the old story, which we had thought dead and decently buried, revived again. Photography is to be a servant of servants; it may hew wood and draw water, or do other mechanical labour; but it must not presume to act as having attained its freedom in the guild of art.

Accordingly, it is against the attempts to make pictures we find the greatest rancour is directed, and Mr. Robinson's noble composition, "Bringing Home the May," has been the especial victim. In the *Illustrated News* we are informed that "photographers only can estimate the difficulty of selecting and posing the different models, arranging and uniting the different studies, and toning into harmony such a work as this; and, perhaps, only artists can fully understand how completely this labour is thrown away. What have we here?—a funeral rather than a gleeful procession." It would not require an artist to discover the difference between a funeral and a gleeful procession; but it certainly would require an art-critic to discover any suggestion of a funeral in the noble picture referred to. Another remarkable fact is discovered by this critic, which photographers will be surprised to learn, is, that "photographers seem disposed to force the power of their lenses more than heretofore; hence the curvature in the lines of architecture, which is becoming so frequently perceptible." Our own conviction, which we held in common with the majority of photographers, was, that this curvature, at one time almost universal, was, since the invention of a lens absolutely free from such distortion, becoming very rare. The remark is made, it is true, whilst speaking of Mr. Bedford's pictures, and charging them with this fault. It happens that Mr. Bedford, in working in the East, used simply the single lens, which, in architectural subjects, gives this curvature; but to base on this fact a statement that such curvature is becoming more common, simply displays ignorance of the real facts. Amongst some just and discriminating remarks, we have many further misuse of terms, displays of ignorance of the art, which are sufficient to show the worthlessness of the general opinion. We have, for instance, talk about "the inevitable focal distortion," whatever that may be; about the enlargement of the "spectrum," by which is meant not a spectrum at all, but the point of light in the eye. We have familiar talk about the photozincography of Col. James, and the chromo-carbon printing of Capt. Scott as distinct processes; and more to the same purpose. It is somewhat amusing to find that the

objections of this critic are little more or less than wholesale plagiarism from Lady Eastlake's article in the *Quarterly Review* on Photography, some half dozen years ago, and which, we need scarcely inform our readers, was a very different thing to the photography of to-day. The critic in the *Illustrated* reached the end of his article and the climax of absurdity together by informing his readers that Mr. Breese exhibits instantaneous stereographs in which is a "painted moon." We commend to him the task of painting—in lights into any photographic transparency on glass, without the added difficulty of making his "painting" stand the test of the stereoscope.

The *Daily News* has always been distinguished by its just and appreciative view of photography; but the advance of certain phases of photography seems to have startled it into injustice. We are told that photography "continues trenching closer and closer upon the territory of the artist proper; that we rub our eyes as we ask ourselves whether all this is art or art manufacture, and whether the taste for the photograph indicates a healthy feeling for art in its nobler forms, or merely a rage for having the eye tickled, as it were, with close imitations." And we are further told that other "instances of a vulgar and degrading tendency of photography in some hands" is found in pictures of "the sea struck by the instantaneous process into a sort of petrified ploughed field." We are here willing to put against the dictum of the critic the opinion of the President of the Royal Academy, Sir Charles Eastlake, who when he first examined an instantaneous stereograph of the sea, exclaimed that, compared with this, he had never before seen the sea delineated by any method. On the production of subject pictures, the *Daily News* is more intolerant still, as "a development of the art more offensive than any other." "Bringing Home the May" is styled a "particularly conceited attempt of this kind;" the budding May is called "ridiculous looking stuff, more like sponge than hawthorn blossom." How a good photograph of May blossom should look like something else, we leave the critic to explain; but we may remark that he has evidently fancied that the photograph was not from nature, since he speaks of such pictures as being produced from "properties and living lay figures." The last time the *Daily News* noticed an exhibition of photographs, Mr. Robinson's composition pictures were selected for especial praise; they are styled "simple," "natural," "pleasing," "beautiful;" and it was hoped they "would bring him the fame he deserves."

The *Illustrated Times* attacks the same phase of photography, and informs photographers that they mistake their vocation in "making subjects out of dressed-up figures, and sundry shrivelled greenery and rock-work." In this remark we agree with the critic; but we are bound to add that we have not seen any pictures produced from such materials in the present Exhibition.

Various other reviews of the exhibition have appeared with criticisms of similar tendency, the only thoroughly genial and appreciative notice appearing in the *Morning Post*.

We may mention here also a drearily funny article in a recent number of *Chambers' Journal*, with the title of "The Modern Priests and Temples of the Sun." The chief idea that strikes us in reading this article is wonder at the amazing misinformation it contains. The ignorance of the writer appears to be of that character which has been styled as "not only comprehensive and vast, but very elaborate and minute." We are told, for instance, that a photograph always inverts the figure, making the right hand the left, &c., and that "this diabolical perversion was doubtless invented by photographers," &c.; for what purpose do our readers think? The writer says, "in order to compel us to have *cartes de visite* taken!" This class of picture being, it is added, the only kind free from this perversion. We are told that a photographic studio "poisons the air" in the neighbourhood where it exists with the fumes of collodion! The writer affirms his conviction that there is little difference between a photograph done by the best artist and a sixpenny glass positive. This latter remark, by-the-by, explains the first. The writer has doubtless qualified himself for writing on the subject by obtaining a portrait, "frame and glass included, for sixpence." There are a great many similar complaints equally silly and equally untrue. In a case of this kind some allowance must of course be made for the writer's desire to be funny: there might easily have been more real humour, however, as well as truth.

Photographers generally look with great interest for criticisms which are supposed to represent public opinion. When these criticisms are honest and free from warp or bias, they are often valuable as presenting suggestions and hints from a fresh and untechnical point of view. Many of the remarks in the notices of the daily papers to which we have alluded are interesting and discriminating, especially when accrediting the art with its acknowledged unparalleled powers of literal reproduction. But where it threatens to trench upon the province of what they are pleased to term "art proper," the animus at once becomes apparent.

We have another criticism on art photography coming from another quarter, which will be found on another page, and which we cannot reproduce without a word of comment. Our esteemed friend, Mr. Sutton, recently communicated to the Photographic Society of Scotland a paper "On some of the Uses and Abuses of Photography," which will be read with much interest. But there are certain portions of the paper against which we must protest, as being, in our view, repressing and discouraging to the earnest and ambitious photographer. Mr. Sutton objects to picture-making by photography. He says:

"What you want in a work of art is not an exact and truthful resemblance of a group of natural objects, however cleverly arranged and lighted, but a reproduction of such objects, or of a new combination of such objects, according to impressions which they have produced upon the human mind. The first chalk drawings of a schoolboy upon a wall are, in my opinion, more admirable, from the human interest which they possess, than the finest view of inanimate natural objects upon the ground glass of a camera obscura."

We cannot here enter into the whole question, upon which we have often before expressed our opinion; but whilst we demur to the canon of art laid down, we also affirm that if it were true, photography can largely fulfil its conditions. First, we demur to the canon that an exact and truthful resemblance of natural objects is not wanted in a work of art, but that somebody's impressions of such objects constitute art. Art has many phases: high art or heroic art must present nature idealized and ennobled, or at least in the highest and loftiest aspects of which it is capable. We do not assert the power of photography here. But art also possesses phases in which exact and truthful resemblance are the highest qualities, and here photography claims the power to produce genuine works of art, capable of giving pleasure which neither palls nor diminishes. Where photography most fails in producing works of art is just where

it fails being truthful. If it could produce colour as well as form, the most skilful pre-Raphaelite might strive in vain to produce works of art equal to the camera. The one lesson which great artists have ever pressed on the attention of students has been to present nature truthfully, and not in the conventional garb of their own impressions.

But, in the second place, photography can and does to some extent present nature according to the impressions of the photographer. Else, how is it that each photographer has his style or manner as distinctively as various painters? The photographer with a coarse appreciation of natural beauty will give us coarse photographs, wanting entirely the delicate detail, the soft gradation, the tender aerial tints which render the more skilful artist's productions so charming. As to almost all the qualities which constitute style, at least in monochrome, the matter is quite under the control of the photographer. It is true, except with very bad treatment, the lens will not generally give the bad drawing in which some painters indulge; but, as regards grouping and arrangement; point of view and choice of light; the production of flatness or relief; delicacy and detail or vigour and suggestive masses, &c., the effect is as much under the control of the photographer as it is in the hands of the painter. One photographer will make a beautiful picture, and another an ugly portrait of the same sitter; one will tell a story, and the other will produce an unmeaning group with the same models; one will make a landscape look a place to be shunned, and another will make of the same place fairy land. In short, each will present his subject largely as it has produced an impression on his own mind.

We do not make any arrogant claims for photography. We know there is much sad inartistic stuff produced; we know that its best phases cannot rival the highest phases of art. We know it lacks the glorious charm of colour; we know that the finest monochrome must be to the many-lued scenes of nature but—

"—As moonlight unto sunlight,
And as water unto wine."

But we know also that photographs may be pictures, genuine works of art, refreshing the eye, and largely satisfying us with the recollections of beauty they recall. We esteem Mr. Sutton highly, and respect his opinions; but we cannot but regret that an authority so highly regarded should thus slight an important phase of the art. Outside criticism of this kind we can smile at; but when the wound comes from within the charmed circle, we cannot but recall Byron's lines:—

"Keen were her pangs, but keener far to feel
She nursed the pain that impelled the steel."

ARTISTIC COPYRIGHT.

A MEETING of painters, engravers, &c., was recently held at the French Gallery, Pall Mall, for the purpose of considering the best means of obtaining a more effective copyright in engravings. As the subject is interesting to photographers, and we wish to make one or two remarks on the subject, we condense from the daily papers a brief account of the proceedings:—

"To illustrate the facility and success with which the finest and most costly works on which a great amount of combined genius, skill, capital, and labour may have been expended, both by the painter and the engraver, pirated copies of the following subjects, made by photography, zincography, lithography, and the anastatic process, were exhibited in the room side by side with the original engravings from which they had been taken:—Portrait of the Empress of the French, engraved by Danguin; the "Parce Somnum rumpere," engraved by Raphael Morghen; Landseer's 'Monarch of the Glen'; Hunt's 'Light of the World'; Rosa Bonheur's 'Horse Fair,' &c. It is almost unnecessary to say that the genuine production and the spurious imitation in every case so closely resembled each other as to be

scarcely distinguishable, although the fair price of the one might be half a guinea or a guinea, and the other could easily be sold for a shilling.

"In introducing the business, the Chairman explained that the Act relating to Works of Art passed last Session recognized the painter's claim to the copyright of his pictures for a given period, and the photographer also enjoyed legislative protection, but the property of the engraver was still left wholly insecure.

"Mr. FRITH (who was unable to be present), in a letter, said:—"The recent Act is efficient as regards the copying of pictures, but while the remedy of the publisher, who has paid liberally for a copyright, is not secured to him by law against photographic piracy, he will be neither willing nor able to pay for copyright as heretofore; and, if that should happen, the class of art I practise will almost cease to be followed. It is to me incredible that the law should give a quick and cheap mode of redress to the photographer whose works are pirated, and refuse it to the publisher whose stake is so large, and the object of whose speculation is often so creditable."

"Mr. GAMBERT, art publisher, addressed the meeting, forcibly pointing out the peculiar hardship under which his class laboured by having their best engravings, produced at a heavy outlay, pirated by any man who had a little skill in photography, and could muster 6d. to invest in a few chemicals. The injustice of this was all the more flagrant inasmuch as the photographer who thus unscrupulously robbed the engraver was himself amply protected against piracy on the part of his rivals. No publisher would venture to give commissions, involving thousands of pounds, to artists like Mr. Frith or Mr. Holman Hunt, while the law left their property an easy prey to such unprincipled depredators. Thus, art must be discouraged, and the public would suffer.

"Mr. Herbert, R.A., Mr. E. Nicholls, R.S.A., Mr. Thomas Landseer, Mr. Redgrave, Mr. Tom Taylor, and other gentlemen, having also addressed the meeting, a series of resolutions was unanimously adopted insisting on summary redress against this particular class of piracies by proceedings before any two justices of the peace, together with the improvement and consolidation of our own laws relating to artistic copyrights, and the expediency of an assimilation of the codes of the great European countries on this matter. The business closed with several formal votes of thanks."

We most cordially agree with the proprietors of engravings in the importance of obtaining a more swift, simple, and sure remedy against piracy, than at present exists in the engraving copyright Acts. But we cannot help pointing out a fallacy which we are surprised to find generally held and expressed without contradiction at the meeting. Mr. Frith, for instance, says, that the recent law protects pictures but not engravings. But, does not he perceive that if the picture be protected, the engraving of it must be also secured by that very protection? The owner of the copyright in a picture is protected from copies being made by any process whatsoever. He alone has the right to photograph, engrave, or duplicate that picture by any means, and a copyright exists in each copy by any method. If, therefore, he issued an engraving, and that engraving be copied by photography, such copying becomes an infringement of the copyright in the original picture. This of course only applies to pictures enjoying the protection of the recent Act, and does not apply to many valuable engravings already in existence, the property in which is injured by piracy, and in regard to which a more simple remedy is imperatively required. We wish those concerned all success in securing such a remedy. For, whilst we are deeply interested in the dissemination of cheap art, we have no sympathy with those who would secure it by the sacrifice of private interests.

PHOTOGRAPHIC EXHIBITION.

AWARD OF PRIZES.

THE adjudicators appointed by the council of the Photographic Society to award the prize medals for the best contributions representing six phases of the art, have just tendered their report. We stated in our last that, regarding the majority of the medals, little hesitation would exist as

to whom they should be awarded to; but that in regard to landscapes the task would be one of some difficulty. We find from the report that our own views have been shared by the adjudicators. They state that in reference to four of the medals they had no hesitation in coming to a conclusion; that in portraiture the merit was more divided; and that in landscape it was almost equally shared by many contributors. Although it is probable that in regard to some of the decisions opinions will vary, we cannot but think that on the whole the awards will give satisfaction. They stand as follows:—

M. Claudet, for the best portrait or portraits.

Mr. F. Bedford, for the best landscape or landscapes.

Col. Stuart Wortley, for the best instantaneous picture or pictures.

Viscountess Hawarden, for the best amateur contribution.

Mr. H. P. Robinson, for the best composition picture from life.

Mr. Thurston Thompson, for the best reproduction.

We must delay further criticism of the exhibition until our next.

SILVER IN THE WHITES OF ALBUMENIZED PRINTS.

BY JOHN SPILLER.

WITH reference to a former communication which you did me the honour to insert in the PHOTOGRAPHIC NEWS (vol. vi. p. 470), I beg leave to request that you will permit me an opportunity of resuming the subject, and of describing some of the results met with in a course of experiments directed to the removal of traces of silver from the whites of albumenized prints. The difficulties to be overcome appear greater, as one chemical agent after another is tried, without accomplishing the desired result; and the object of my addressing to you the present memorandum, is rather to report progress, than to record complete success.

I have already stated, that a second immersion of the print in a fresh solution of hyposulphite of soda, is capable of removing a small proportion of the insoluble silver compound, and that this is the case also when a treatment with iodide of potassium is resorted to. Since the date of this announcement, I have tried the action of a great number of soluble salts, particularly those of ammonia, many of which are distinguished for their power of dissolving the ordinary silver precipitates. Amongst other salts, were the carbonate, acetate, citrate, and phosphate of ammonia; the alkali itself and phosphoric acid separately; tartaric acid and Rochelle salt. None of these were capable of removing the last traces of silver, and there was so little advantage gained by their employment as auxiliaries to the fixing bath, that I have been led to try the cautious use of cyanide of potassium. By immersing the prints in very dilute solutions of the cyanide, I have succeeded certainly in removing every trace of silver from the whites, but always at the expense of the shaded portions of the picture, for so readily soluble are the metals, silver and gold, when in this extremely fine state of division, that it will, I believe, be practically impossible to limit the solvent action in the manner intended. By operating upon over-printed proofs, on albumenized paper, I obtained pictures which were presentable, but I do not consider that the details were so delicately rendered as in the case of other prints obtained from the same negative by ordinary treatment. The albumen itself, at this stage of the process, does not appear to suffer by immersion in aqueous cyanide of potassium, of the degree of concentration (one grain, or less, in the pint of water), that would be requisite for this particular application.

Terro-cyanide of potassium has the property of dissolving many insoluble compounds of silver, but, according to my experience, is of no value for the purpose at present in view.

In your report of the proceedings of the Marsilles Photographic Society, November 8, 1862,* allusion is made to the

* Vide PHOTOGRAPHIC NEWS, vol. vi., p. 536.

proposal of M. Messnier, to employ the sulpho-cyanide of ammonium as a fixing agent in photography; and your correspondent further states, that the subject has been referred to a committee, to inquire into, and report upon the chemical value of this suggestion. Pending the decision of the French investigators, it may not be out of place to describe some of the characters of this salt, which have presented themselves in the course of preparing and employing this substance as a fixing agent.

There are three processes available for the preparation of sulpho-cyanide of ammonium:—Synthetically, by acting upon hydrocyanic acid with excess of yellow sulphide of ammonium, and evaporating to dryness over a water bath. Or, by virtue of double decomposition, on dissolving in a small bulk of water equivalent quantities of sulpho-cyanide of potassium and sulphate of ammonia, and adding alcohol or methylated spirit, when the sulphate of potash is precipitated, the sulpho-cyanide of ammonium remaining in solution. The third plan is but a modification of the second, and consists in fusing together the yellow ferro-cyanide of potassium with half its weight of sulphur, dissolving in water, and treating the crude mixture of the sulpho-cyanides of potassium and iron first with sulphide of ammonium to precipitate the iron, and then with sulphate of ammonia and alcohol as before. It is necessary to take care to exclude the presence of free sulphur and hydro-sulphuretted compounds from the products obtained by the first and last of these methods; for, unless perfectly purified, the salt is apt to discolour the whites of the photograph. The crystals obtained on evaporation are transparent and colourless, but the aqueous solution seems liable to undergo a gradual decomposition accompanied with the production of a yellow or reddish colour. The solution, when mixed with nitrate of silver, gives at the first moment of contact a bulky white precipitate of sulpho-cyanide of silver, which, left to itself, soon assumes a granular character, or becomes distinctly crystalline; this precipitate is, however, readily dissolved by an excess of the ammonium salt, and the addition of a soluble chloride to the solution yields no precipitate. Both the chloride and iodide of silver are to some extent soluble in the sulpho-cyanide of ammonium, but not nearly so freely as in cyanide of potassium or hyposulphite of soda. On testing the power of this salt in removing the traces of silver from the whites of albumen prints, I find that it succeeds perfectly; but, at the same time, it must be confessed that the sulpho-cyanide of ammonium is not likely to become a cheap commercial article, and on this account its general use as a fixing agent must for the present be seriously impeded.

We learn from the interesting extract from the *Bulletin de la Société Française de Photographie*, which you printed last week, that the eminent French chemists, MM. Davanne and Girard, have resumed their investigation of the compounds formed by the action of nitrate of silver upon albumen. Referring to the announcement I made in your columns on the 3rd October last, they claim the prior publication, in the year 1859, of the fact of silver being contained in the unexposed parts of albumen prints; and, on looking more fully into the matter, I concede to them the merit of having first made this observation; but it must, on the other hand, be allowed that their statement refers to a mode of conducting the fixing and toning processes which is now obsolete, which seldom gave pure whites; and, according to their own description, the silver compound was faintly visible on the paper, and sometimes even was slightly affected by light.* This is certainly not the case with the photographic surfaces I have examined; and, further, I do not coincide in their opinion that the compound under discussion is "probably a sulphide," since the very existence of the silver was discovered by the sulphide of ammonium test, and the production of the brown sulphide on moistening the pure whites with this re-agent must surely be the result of a chemical change. If the exposure of a sensitized sheet

be delayed until it has commenced to assume a visible discolouration, or the print be fixed in hyposulphite of soda without previously removing the whole of the free nitrate of silver, we obtain a condition of surface, to which MM. Davanne and Girard's description is more nearly applicable. These gentlemen are of opinion, moreover, that the presence of the argento-albumen compound is not likely to affect the permanence of the photograph, and so have not been led to study the means of removing or decomposing the same.

Royal Arsenal, Woolwich.

PRINTING DIFFICULTIES.

BY A PHOTOGRAPHER'S ASSISTANT.

SANGUINE as my views are respecting the glorious future of photography, I feel firmly persuaded that the art must ever remain unfettered by fixed rules or formulas, for it will not condescend to be governed by any unalterable number of grains, pennyweights, or ounces, imperative in its demands. It requires the careful hand and intelligent observant mind to guide its ever-varying operations to a successful issue. The above remark is offered as a caution to photographers, who may feel inclined to think that the science of sun printing is at length reduced to a mechanical operation, and, as such, may be entrusted to any blunderer to perform. Although the results I have described were arrived at ere I jumped at conclusions, I deemed it prudent to sit me down, and materially assisted by a soothing "weed," mentally went through the experiments again, the result of these cogitations was a complete modification of my former impressions concerning toning action, so that I am about to start a new theory, powerfully supported by practical, and I may almost venture to add, conclusive proofs; but, ere I proceed to explanations, it is necessary to show the conditions necessary to secure perfect prints, without the necessity of much over-printing. The print on the surface of highly albumenized papers (for reasons before given) is composed chiefly of albuminate of silver. This salt, though more stable than the chloride of the same metal, unfortunately happens to be less sensitive to the influence of actinism; it therefore necessarily follows that prints executed in a dull light must be attended with results not very desirable; there is found wanting that regular gradation of tone, that must be present ere a picture can be pronounced perfect, the light penetrates the shadows, but, its reducing power is not sufficient to act through the semi-opaque portions of the negative that represent the half tones. Hence we have harsh and unsightly contrasts, but the evil rests not here, a bright light possessing the strongest powers of permeation is enabled to produce a deeper deposit by its reducing influence, than can possibly be effected by the weaker actinic rays; hence, in the latter case, provision must be made to meet the difficulty, and this might be effected in two ways; first, by judicious printing; secondly, by a modification of the bleaching or reducing power of the toning solution. If the first-named method be adopted, we must carry the printing in dull light much further than will be necessary in a brighter one, because the reduction, deep as it may appear to the eye, is too slight to bear much bleaching; the reduced film is weak and superficial, whilst the print produced by a bright light, though apparently the same depth, is, in reality, considerably deeper; the light penetrating the minute interstices causes a greater depth of reduction, without the fact being made apparent to the eye; in this case we need go but little further in printing than is required in the finished picture; and if the toning bath is made to suit the latter, it would be found that both classes of prints, if toned together, would exhibit but little difference in their appearance. If we have bright weather, a little over-printing is of slight importance; it is during the dull seasons of the year that the difficulty is most felt. We wish to get through the largest possible number of prints daily, to meet the urgent demands of customers; and, consequently, any method that will effect that object is valuable. As I am still

* Vide PHOTOGRAPHIC NEWS, vol. iii. p. 233.

speaking of highly albumenized papers,* I would strongly advise those who prepare those papers to increase largely the chloride salts employed, for from this source alone we may expect to obtain the necessary conditions of sensitiveness, combined with softness, both matters of extreme importance when printing with a dull light; and to prevent reduction in toning, let the solution be decidedly alkaline. The bath will work very much slower—a matter of little consequence, as this operation may be conducted at any hour of the day or night, so that time is actually gained, as it removes the necessity for printing deeper than when the reduction is produced by a bright light. Direct sunlight, in my opinion, should at all times be avoided for portraiture, save when printing from a strongly contrasted negative. But let the light be strong or weak, more particularly with the latter, the strength of sensitizing solution should never be below 80 grains. Nor should it exceed 85 grains per ounce; and the time of floating should be at least ten minutes; the more prone the paper is to incaliness, the longer should be the floating, by which, in so strong a solution, the albumen cannot be injured. The sensitizing operations should be conducted in a warmed room, and the paper allowed to dry spontaneously; but if circumstances should render it necessary to dry before a fire, we must be observed to avoid doing so before the paper has become surface-dry; for, during the process of drying, the solution upon the paper's surface divides, and towards numberless centres the surrounding atoms are drawn by molecular attraction, forming small globules, which, on removal by rapid evaporation, leave indentations which render the paper quite unfit for printing purposes. If these instructions are strictly and intelligently followed, I believe those who practice them will admit the correctness of a statement made in a former letter—viz., that a clear print may be produced on every paper in the market if its requirements are carefully studied; for, in my experience, I have found that every paper requires a separate or modified treatment; and, as the various samples of gold are subject to changes in the quantities of acid they hold in combination, no fixed formula can be given to produce the necessary qualification for satisfactory toning; but the following explanation, on toning action, will enable anyone to manage his toning solution under all circumstances, that is to say, when carbonate of soda is employed.

Other mixtures will engage my attention, after the completion of this paper, if circumstances permit.

(To be continued.)

THE ADVANTAGE OF A STRONG NITRATE OF SILVER BATH FOR SENSITIZING ALBUMENIZED PAPER, DEDUCED FROM A CONSIDERATION OF THE PHILOSOPHY OF ITS ACTION.

DEAR SIR,—For a comprehensive view of the subject I have chosen for my present letter, I must shortly recapitulate what I have already stated in former communications.

The discoloration of the nitrate bath which takes place when sensitizing albumenized paper, is due to the solvent power the water exercises upon the dried albumen; therefore, in proportion to the power, and the time given for its action, so must the brilliancy of surface be impaired; any means that will mitigate or destroy this power, either previous to, or during sensitizing, must consequently be beneficial. Albumen in its *normal* state being capable of coagulation by various means, it was erroneously assumed that the same means would produce the same effect on it when in a *dried* state. Heat and alcohol were therefore employed, and as by their means the discoloration of the nitrate bath was materially diminished, it was supposed that they had destroyed the solvent power of the water by rendering the dried albumen

men *insoluble*, as insolubility was a known accompaniment of coagulation.

The rapidity with which any substance soluble in water is dissolved in it, is in proportion to its more or less hydrated state at the time it is submitted to its action; and the sole benefit derived by ironing the albumenized surface of the paper with a hot iron, arises simply from its desiccating the dried albumen, and thus rendering it more difficult of solution. The addition of alcohol to the bath, from its not being a solvent of dried albumen, merely serves the purpose of mitigating the solvent power of the water. Heat and alcohol have themselves no direct action whatever upon dried albumen; they *cannot* coagulate it, as it is incapable of being coagulated, and *they do not even render it insoluble*; consequently, they only enable the nitrate of silver to act more energetically, from its not having so much antagonistic force to contend against. The benefit also attributed to floating the albumenized paper upon alcohol previous to sensitizing, *exist therefore only in imagination*, having no foundation in fact. Seeking agents for the coagulation of a substance which is not capable of it, and attributing the benefits derived from their employment, to a cause which has not any existence, must necessarily retard the advancement of our knowledge, as the real philosophy of their action is thus not only misunderstood, but attention is also diverted from that of the action of the nitrate bath.

In the sensitizing bath, we have two *antagonistic* forces acting upon the albumenized surface of the paper; the water having power to dissolve the dried albumen, and the nitrate of silver to render it insoluble, the power of either of them is therefore capable of being diminished to any extent by increasing that of the other, and *vice versa*; thus, it is possible to *wholly* overcome the solvent power of the water by *sufficiently increasing the quantity of nitrate of silver*.

Any solvent power must, according to its strength and time of action, impair the brilliancy of the albumenized surface of the paper, therefore the quicker the dried albumen can be rendered insoluble, the more brilliant will be the prints. There is no doubt in my own mind, that the conversion of the dried albumen and salting chloride into albuminate and chloride of silver *can be rendered instantaneous* by the use of a strong sensitizing bath; and I infer, upon philosophical grounds, that by using one very much stronger than any at present employed, say 250 or more grains to the ounce, a mere drawing of the previously desiccated paper across the surface of the bath will accomplish it.

Sensitizing the albumenized surface, by merely drawing the paper across the nitrate bath, affords the solution no time to penetrate its substance; and the image being thus purely on the surface, must necessarily be more brilliant than it would otherwise be. I think we are perfectly warranted in assuming that the more superficial the sensitized surface can be rendered, the easier can the toning and fixing be accomplished. I believe, therefore, that prints obtained upon albumenized paper thus sensitized, will not only have the utmost brilliancy and vigour which albumen is capable of offering, but will also be rendered more permanent; and that not only less washing will be requisite, but, less silver will be wasted, from there not being so much unused free nitrate to get rid of.—Yours truly,

GEORGE PRICE.

Mornington Road, New Cross Road, Deptford.

ON SOME OF THE USES AND ABUSES OF PHOTOGRAPHY.*

BY THOMAS SUTTON, ESQ., B.A.

GENTLEMEN,—Your Secretary having done me the honour to ask me to prepare a paper on some subject connected with photography, to be read at a meeting of your Society, I have with much pleasure acceded to his request, and put together the following remarks on some of the uses and abuses of photography, in hopes that they may attract your attention to a

* The lighter samples will be treated on in their turn.

* Read before the Photographic Society of Scotland, January 13, 1863.

new use of our favourite art, which I will endeavour to describe, and also excite a profitable discussion on some other applications of photography with which you are already familiar.

I have now been ten or twelve years closely connected with photography, and have watched its progress with the interest one feels in a favourite hobby. During that time, as successive new steps have been taken in the art, I have endeavoured to weigh their importance, and predict their future effect. Sometimes I have been wrong, and sometimes right, in these estimates which I have formed of the probable practical value of new suggestions and processes; and it is interesting and useful from time to time to consider the course which improvement has taken, and the amount of success and popularity which certain branches of the art have achieved, and the comparative failure of others.

I will endeavour to call your attention, in the first place, to the present commercial aspect of photography as compared with that when I commenced editing my *Photographic Notes*, about seven years ago.

Photographic portraiture upon collodionized glass plates, and positive printing upon albumenized paper, were then, as now, the most important commercial branches of the art; while the sale of large views of even the most celebrated and interesting places was comparatively unremunerative. The stereoscopic slides were also at that time becoming important; and the London Stereoscopic Company, whose operations are now so extensive, was founded. But the portraitists were not then so busy as they are now; and, with the exception of a few leading firms, who did their work in the best style, only very moderate incomes were made. I have often at that time spent fine mornings in the glass rooms of really clever photographers, living in good situations, without seeing a sitter, and have wondered how they contrived to make ends meet at the end of the year. But things have greatly altered since then; photographic portraiture has now become a much more profitable occupation, and to be long without a sitter is a sure sign of incapacity, or some obliquity or vulgarity on the part of the operator. There is now a great and increasing demand for small portraits; and if a man cannot get a living by taking them, it is *his own* fault, and the sooner he finds out the reason the better.

The following seem to be the chief reasons why photographic portraiture has received such an impetus, and why it has become at present the most important use to which photography is applied:—

At the time to which I allude, positive printing was in a very unsatisfactory state; and I am sure that if the card portraits of the present day were printed as badly as the paper portraits were seven years ago, there would be but a small demand for them. I think I am right in tracing to the improvement in the printing process the chief cause of the impetus which has been given to photographic portraiture. Thus, as soon as photographers could print properly, and show people beautiful things, persons of distinction were not ashamed to have their portraits taken and exhibited, until at last Mr. Mayall obtained permission to take card portraits of the members of the Royal Family, and sell them to the public, which permission is one of the choicest instances of good nature on the part of a sovereign recorded in history; for photographs are rarely flattering, and were certainly not so in the present instance. As soon as card portraits of the Royal Family of England could be obtained for a couple of shillings, it is not surprising that other sovereigns followed the example, until at length albums and card portraits came into general esteem.

The most important and remunerative practical use to which photography has been put, is that of taking miniature portraits of distinguished people, and selling them at a price which puts them within the reach of all. How highly interesting it is to look over an album filled with unerring portraits of the ruling sovereigns, and celebrated men and women of the day! What an advantage the present generation has in this respect over those that have preceded! and what an advantage future generations would have in studying history, if *permanent* photographs of the leading men, whose exploits are recorded, could be bound with the volume! It only remains to give the last finishing touch to the carbon-printing processes of Pouney or Joubert to render this possible.

But there is another element of the success of the card portraits which must not be overlooked; and that is their small size. Let photographers carefully note the fact that those branches of their art which have succeeded commercially, consist in the

production of *small* pictures—stereo-slides, for instance, and card portraits; while the large views and large portraits have been a comparative failure. I believe this will always be the case; and although there may, perhaps, always be a certain small demand for large things, yet the professional photographer will, probably, as a rule, find it most to his interest to bend to the convenience and taste of the public for small and inexpensive portraits and views. It is not improbable that a fashion for card views may shortly spring up, and become a remunerative business; if that should ever happen, I advise photographers to multiply small negatives from a large positive print. A vignette-d print from a panoramic negative 10×6 might be copied on a reduced scale, and large numbers of small flat negatives taken from it, from which prints of the card size could be produced in abundance to meet any demand.

Next in importance to card portraiture and card views, comes the use of photography to artists, first in assisting them in the production of works of art, and secondly in multiplying correct copies of paintings, drawings, and sculpture. But I cannot agree with those who think that pictures can be successfully built up or composed entirely by photography after the manner of Rejlander and Robinson. According to my taste, everything that I have seen done by these gentlemen in this style has been a failure, and has afforded increasing evidence of what every true artist knew before to be impossible, and opposed to correct principles. What you want in a work of art is not an exact and truthful resemblance of a group of natural objects, however cleverly arranged and lighted, but a reproduction of such objects, or of a new combination of such objects, according to impressions which they have produced upon the human mind. The first chalk drawings of a schoolboy upon a wall are, in my opinion, more admirable, from the human interest which they possess, than the finest view of inanimate natural objects upon the ground glass of a camera obscura. God created those objects; and He also created man; and man's works are therefore indirectly His works. But man is also the noblest creation of the Deity; and if you follow up this train of thought, you will see that pictures which are the result of human imagination, observation, and *powers of imitation*, are more noble than, and belong to a different class of thing altogether from, the images in a camera obscura, notwithstanding all their beauty of colour and perspective. How much, then, is a work of art more noble than a photograph, with all its imperfections; and what a vast difference there is in principle between a work of art and a camera image! Although I admit the possibility of exhibiting the same artistic skill in arranging objects for the camera as in arranging them for the artist to copy in his own way, yet I maintain that in the photograph of the group there are wanting those qualities which are peculiar to a work of art, and which owe their peculiarity to the fact of the artist's copy *not* being mechanical, but purely the work of human intelligence. The true artist who has mastered the mechanical difficulties of his profession, and takes a high view of its intellectual dignity, will never attempt to build up pictures by photography; in fact, to an accomplished artist, the method would be much too slow, troublesome, and costly, even if the result were not ridiculous. That it is ridiculous is all but self-evident. Can you fancy Tennyson turned photographer, and illustrating his "Lady of Shallot" by a photograph? or Cervantes giving, in the frontispiece of his story of the exploits of Don Quixote, a photograph of a half-drunken model, surrounded with rattletraps and stage property? Are such things possible, I ask? When the Council of this Society, some years ago, banished from the walls of its Exhibition a photograph entitled "The Two Ways of Life," in which degraded females were exhibited in a state of nudity, with all the uncompromising truthfulness of photography, they did quite right, for there was neither art nor decency in such a photograph; and if I expressed a different opinion at the time, I was wrong. There is *no* impropriety in exhibiting such works of art as Etty's "Bathers Surprised by a Swan," or the "Judgment of Paris;" but there is impropriety in allowing the public to see photographs of nude prostitutes, in flesh-and-blood truthfulness and minuteness of detail.

But if artists and poets are not to turn photographers and make such pictures as "The Lady of Shallot" and "Don Quixote in his Study," the artists at least may use photography with advantage in other legitimate ways. An artist who studies largely and conscientiously from nature, acquires in time an originality of style which those who spend most of their life in the studio instead of the field

are fair to copy; and thus arises that plagues of art, "conventionality." The latter class of artists have derived great advantage from photography, because, next to copying from nature, it is good to copy the minute and accurate detail of a photograph in a broad and truthful manner. Artists are fully aware of this, and they have been large purchasers of stereoslides, and it is a common thing for them to cut these slides in half, and exchange duplicates with each other. Thus it happens that slides which have no interest for the public are sometimes largely purchased by artists.

Others, again, like Mr. Frith, use photography largely in obtaining studies for parts of their pictures. Thus, on "A Derby Day," Mr. Frith employed his kind friend Mr. Howlett to photograph for him from the roof of a cab as many queer groups of figures as he could; and in this way the painter of that celebrated picture, the "Derby Day," got many useful studies, not to introduce literally into his picture as Robinson or Rejlander would have done, but to work up in his own mind and then reproduce with the true stamp of genius upon them.

Artists may, and do, in this way use photography largely and profitably; but the tyro in art should never forget that one great secret of success in his profession depends upon his acquiring the power of closely observing the form, colour, and expression of objects, and recording them in his memory. It would not do for Leech or Tenniel to be dependent upon a camera for recording all the funny incidents they may see in London streets. An artist may use a camera occasionally as a help, but he must not trust too much to it.

I will now point out a new use which may be made of photography by persons (like Dr. Livingstone, say) who may wish to illustrate a book of travels with truthful pictures, based upon photographs, but pulled in the printing-press. All that is required to do these things artistically is to practise pen-and-ink drawing until facility is acquired in that art. I have myself made one or two attempts, and with sufficient success to confirm me in my belief that the art is not difficult. The plan is as follows:—

You first take a negative and print a positive from it, in the usual way, or, if you like, without gold toning. The photograph need not be faultless; and a few stains, spots, and comets do not signify, provided the general outline of the objects is preserved. You then lay upon the positive print a sheet of lithographic tracing-paper upon which transfers are made. This costs about eighteen-pence per sheet, demy. Then, either with a quill pen or a fine steel Perryan pen dipped in lithographic transfer ink, you make a pen-and-ink drawing upon the tracing-paper, guided by the photograph beneath. In doing this be careful not to rub the tracing-paper with damp fingers, or let any grease or dirt get upon it. The transfer ink is sold in solid cakes, having a rather agreeable smell, and is rubbed up with water in the same way as Indian ink. In making the sketch, observe that gradation of tint is got, not by using thinner ink, but by drawing your lines nearer together or further apart. In parts of the picture where broad masses of intense black occur, these may be laid on with a brush, but very carefully. Before commencing this art of pen-and-ink drawing, study carefully some good etchings or wood engravings. The amount of finish required will depend, of course, upon the nature of the subject. It is better to aim at producing a broad and suggestive effect, with the minimum of work, than to get into a small, laborious and niggling style. All the masses or systems of lines by which the various shades are produced must be drawn in a suitable direction, and with a masterly touch evincing forethought in the artist. When the sketch has thus been made, you immediately send it to a lithographic printer, and he in a few minutes transfers it to zinc or stone; and from this impression any number of prints can quickly be pulled for the purpose of book-illustration. You must not think it heretical in me to say so; but I generally like these sketches better than the photographs from which they were taken, however perfect the latter may be. There is a firmness and crispness about an etching or pen-and-ink sketch which photographs do not possess, to say nothing of their pretensions to a fine-art character when properly done. There is a great advantage also in being able to utilize bad photographs, or rather in being a little independent of the messes into which photographers sometimes get.

Now that rapid dry plates are coming into fashion, artists will find it a great help to them to use these plates with a reflecting camera, for taking groups of figures, animals, &c. I have sent Mr. Ross a plan of an artist's reflecting camera, constructed expressly for this purpose; and I am sure that an instrument

of this sort, with rapid dry plates, would be of great value to artists. In fact, photography ought now to be made a part of the course of instruction of every artist.

The magnificent series of photographs lately published by Messrs. Cundall and Downes, of the pictures in Turner's "Liber Studiorum," prove convincingly the great use of photography for reproductions of this kind. Mr. Bingham's admirable photographic copies of paintings seem also to leave nothing to desire. Should it be said that photography fails somewhat in the truthful rendering of colour by shade, yet, on the other hand, you are certain of preserving expression, which is a matter of greater consequence. Who would not rather have a fine photograph by Bingham, of Guido's celebrated picture of "Beatrice Cenci," the expression of which has been found so difficult to render faithfully by engraving, than a print of the same?

Photo-lithography is another very useful application of photography; and wonderful reproductions of maps and line drawings have been made by its means, in the hands of Sir Henry James, Mr. Osborne, and Mr. Ramage. The attempts which have been made to print by this process from ordinary negatives, by Macpherson, Poitevin, Lemerrier, and others, have been less successful; but I really must say that Mr. Pouncy, of Dorchester, has got a step in advance, and done some good things. Take, for instance, his view of Killarney, published in my "Notes;" that is surely excellent. My impression of this process is, that it is suitable only for a certain class of subjects, of which Killarney is a good illustration, and that the fault has hitherto been in attempting to apply it to the wrong kind of subjects. The subjects for which photo-lithography is suitable, are precisely those for which lithography is commonly employed, and of which Mr. J. D. Harding's lithographs are the type. If photo-lithography can produce works of this class, without the conventional mannerism which many artists acquire, they will be very useful to artists and drawing-masters. But it must be remembered that the grain of a lithograph is one of its characteristic features; and photo-lithographs must always, from the very nature of the case, have a grain. In this respect they must always differ from common photographs. A lithographic printer will always tell you of the importance of "keeping the work open;" for as soon as the grain becomes blocked up there is an end of half-tone, and the proofs exhibit dense patches of black. Bold bits of detail are the kind of thing for photo-lithography; and these bits will only be found by a man who thoroughly understands what is required, and has a great deal of taste and artistic feeling. They may be taken upon paper, and with this advantage, that the negative can be reversed in the printing-frame, if necessary. The fine detail of a glass negative is not required. Jersey abounds in studies for the photo-lithographer, although it is rather a bad place for general views.

There are two processes of photo-lithography—one in which the stone is coated with a solution of asphaltum in ether, benzole, or turpentine; and the other, in which it is coated with a mixture of bichromate of potash and gelatine. The former process is that of Mr. Macpherson, and I believe also of Mr. Pouncy; the latter of M. Poitevin and Sir Henry James. It is impossible for me to say which is the better; but the former not only allows you to grain the stone, but also the sensitive coating of asphaltum, before exposing it under the negative. While on the subject of asphaltum, I may mention the possibility of taking permanent prints upon paper with this substance, with all the fine qualities of a silver print, except its beauty of colour. The asphaltum prints have a very disagreeable yellowish-brown tint; and their only recommendation is their permanency, about which very little doubt can exist. For some subjects, however, the colour is not unsuitable.

The phototype process of M. Joubert is very nearly all that one could desire for good carbon printing upon paper. It is a great pity that photographers do not club together and buy it. The sum required by M. Joubert has never been publicly named; but he has confided to me the amount for which he would dispose of it, when I was in treaty with him, a year ago, to buy it for my own use, and I thought the amount reasonable, although more than I felt justified in giving on my own responsibility. If the required sum could be subscribed quietly, and in a way not unpleasant to M. Joubert, it would be money well laid out. If I could be of any use in privately furthering a scheme of this kind, I should be most happy.

Very little appears yet to have been done in the application of photography to scientific purposes, chiefly, I think, because

the collodion processes are employed instead of the daguerrotype. A great deal has been said about Mr. De La Rue's experiments in celestial photography; but I really cannot see that they have proved anything. Take, for instance, his stereo slides of the moon: those merely illustrate the fact of the roundness of the visible part of the moon, which was known before, and they do not prove that the mountains stand out in actual relief, as some people suppose they do. If a smooth globe were painted with dark patches, and stereo views of it were then taken from different stations, these duplicate views would make the painted patches appear in relief, and that relief might easily be mistaken for the kind of relief due to unevenness of the surface of the sphere. Sir John Herschel has had something to say on this subject lately in the *Cornhill Magazine*, but he does not attach undue importance to Mr. De La Rue's slides, or make it appear that they have proved anything new. The photography, in Kew Observatory, of the solar spots has not yet amounted to much; and it will be found, I am sure, before long, that a better instrument and better process are necessary to produce valuable results.

I have now, gentlemen, endeavoured briefly to call your attention to some of the uses and abuses of photography, in hopes that my remarks may lead to a profitable and animated discussion. I have mentioned in my paper the names of Robinson Rejlander, and De La Rue; but it must be distinctly understood that I meant no disrespect to these gentlemen; on the contrary, I consider them very talented in the particular way in which they excel. Mr. De La Rue is a gentleman who undoubtedly stands high in science; and Messrs. Robinson and Rejlander are not less distinguished in legitimate photography.

I have enclosed a few sheets of my patent albumenized paper for distribution among the members, and also a print upon it taken from a panoramic negative. You will observe in this print the perfect purity of the whites, and the extraordinary vigour of the blacks, without any bronzing. There are also a sheet of blotting-paper and a sheet of plate-paper, one half of each of which has been dipped in the india-rubber solution, and the other half not. You will see that you can write upon the half which has been treated with india-rubber as well as upon common paper, but not, of course, upon the other half. This proves the effect of the rubber solution as a sizing material; and if the ink does not sink into blotting-paper when treated with it, it will easily be understood that the albumen will not sink into photographic paper when so treated. I have also enclosed a sheet of Rive paper prepared with the rubber solution, so that you can see it before it is albumenized. You will observe that there are no visible traces of the india-rubber either upon the Rive paper or the blotting-paper, and that it does not stain the paper, or visibly affect it in any way; neither is there much smell.

I have great hopes that prints upon the patent paper will be found more permanent than those upon common paper, on account of their absorbing moisture less readily. I have immersed finished prints in the rubber-solution, and this, I think, will afford great protection to them. The treatment does not in any way affect the purity of the whites, and it seems to make the surface shine still more. I think it very desirable that valuable card portraits should be treated in this way.

If any of the members of your Society would like to send me some of their negatives, I will, with pleasure, send a print from each, upon the patent paper, for your Society's Album or for exhibition at a meeting. I am very anxious to get some good negatives to print specimens from, in order in the spring to have an exhibition of positive prints at Mr. Lamprey's warehouse, in Paternoster Row, and to be able to send round to the different Photographic Societies a portfolio of fine and varied specimens.

THE APPLICATION OF PHOTOGRAPHY TO THE MAGIC LANTERN EDUCATIONALLY CONSIDERED.

BY SAMUEL HIGHLEY, F.G.S., F.C.S., &c.*

AS TO THE PRODUCTION OF THE POSITIVES, OR TRANSPARENTS OF GLASS.—Following the system of the Microscopic Society, we ought to adopt a standard gauge for our glasses, say three-and-a-half inches square for views for the general run of lanterns. The process—old structureless collodion,

exposure in diffused light—the nearer it can be brought to a standard character the better. Iron development, after intensification with pyrogallie acid by Major Russell's process; fix with cyanide of potassium, varnish the picture to give transparency to the film, mount between two glasses; or the albumen process may be followed with advantage, especially for "superposition printing."

Where, however, lantern views are to be prepared for trade purposes, it is better to produce them by "camera printing," from negatives of large size, for by this method the producer is enabled to supply views, larger or smaller than the standard size suggested, according to the special requirements of his customers, and greater definition or sharpness is likewise attainable. I have stated that the nearer we can bring the light employed for printing transparent positives to a standard character the better, for the operator would then attain to uniform results, and loss through failures would be greatly diminished. It is also desirable that the operator should be made independent of the sun's light, for after two seasons' experience I find that when the stock of views one has prepared during the summer months is carried off, at the time of demand, the winter months, through failing light, it is difficult, at times impossible, to meet the requirements of would-be customers. To avoid this annoyance I have lately given my attention to the production of an artificial light, rich in actinic or photogenic rays, cheap in production, and that could be turned on or off as required, with what promise of success I will presently demonstrate.

It is true that we could use carbon points, or a fine stream of mercury, brought to a state of intense ignition by means of the electricity produced by forty Groves's cells, but both the ordinary electric light, and Way's mercurial electric light, are too costly in the "plant" to be economically considered. It is commonly believed, and frequently stated in some of the photographic journals, that the oxy-hydrogen light may be employed for photographic purposes, but the fact is, and I wish it to be distinctly understood, that though very brilliant and intense, it is peculiarly wanting in actinic rays. Some time since, my friend, Mr. Charles Heiseh, was preparing a lecture on photography, and wishing to give an illustration of the method of producing a picture, he thought he should be able to demonstrate the point by aid of the oxy-hydrogen light, but he found, experimentally, that while he could produce a sharp picture of a white bust, instantaneously, by the electric light, he could only produce a dingy image of the same object after twenty minutes' exposure to the oxy-hydrogen light. It is well known that if an artificial light emits fluorescent rays (known by their peculiar effect on bodies possessed of the character called by physicists "fluorescence"), that light is also rich in actinic or photogenic rays. I shall now show how far the light I have been experimenting on is likely to be of utility to photographers. [Mr. Highley here turned on from a gas-jet a bright violet sheet of flame that made an uranium glass, brought into its presence, glow like a gem.]

The cost of production is always a legitimate subject of discussion, and I may, therefore, state that, taking into consideration the cost of production of negatives (our engraved plates, so to speak), the cost of making the existence of the subject known, in other words, the advertising charges, and the cost of producing the transparencies, photographic magic lantern views can be sold to the public for five shillings each, plain, and eight shillings and sixpence coloured, while the ordinary magic lantern pictures, which, as I have previously stated, cannot for one moment pretend to embody the same amount of detail or truthfulness to nature, sell at just double that price, that is to say, sixteen shillings coloured, if of the same size and pretensions to artistic excellence. On the other hand, it should be stated that photographs involve a slight extra expense in the apparatus required, for an oxy-calcium or oxy-hydrogen light, and achromatic lenses are essential for their perfect exhibition.

As ordinary magic-lantern pictures are in the main made up of patches of colour, they can be shown by lenses that do not require great optical perfection; as, however, photographs are made up of detail, if they are shown with lenses that are not achromatic, a fringe of colour will be apparent on every line, and this defect in the optical parts of the apparatus used in their exhibition, will tend to produce a blurred effect, in fact a picture wanting in definition.

But photographic magic-lantern views, even when not in use, may be made available for educational purposes; for I would

* Continued from p. 44.

suggest, that, if they represent Natural History subjects, instead of stowing them away in boxes, they should be placed in the open cases of museums, &c., beside allied objects, care being taken that they are fixed at such an angle that light should be reflected through them, by aid of a piece of white paper placed behind the transparency—or by mounting the views in long frames backed with fine ground glass, they might serve as appropriate borders to the windows of a scientific institution.

To make our system perfect, it behoves the producer of photographic lantern views to consult the requirements of the curator or travelling lecturer, and make the demonstrating apparatus as compact and generally useful as possible. I have therefore given thought to these important points, and now beg to call your attention to some of the contrivances I have introduced.

The sources of light may be the electric lamp, which, from its intensity, is well suited for institutions or large lecture theatres; yet for ordinary use it is too expensive, as it cannot be worked to advantage with less than forty of Groves's cells, and these, with a lamp, cost not less than thirty pounds (without a lantern). Some lamps, such as Serrin's, cost, *per se*, twenty pounds, but at the International Exhibition I exhibited a novel form of automatic electric lamp, founded on a galvanometer arrangement, the invention of Dr. Squire, which, when perfected, will be quite as efficient as those of our French neighbours, Dubosq and Serrin, and cheaper through there being a simplification of parts. A model of this lamp is on the table.

For general purposes, the oxy-hydrogen light is most efficient, and as the pure hydrogen formerly employed is now usually replaced by ordinary house gas, the trouble is greatly diminished. Undoubtedly pure hydrogen gives a better light than the carburetted form, and when house gas is not attainable it may be best produced from a leaden generator, constructed on the principle of Doebereiner's lamp. The vessel being divided into two compartments, the lower part is filled with sulphuric acid and water till it runs out at the tap; the tap is then closed, and the acid mixture acting upon a cylinder of zinc supported on the outside of a tube connecting the upper with the lower chamber, causes hydrogen to be generated, which, having no vent, forces the liquid up the tube into the upper chamber; as soon as the acid is removed from contact with the zinc, the production of gas ceases. On the tap being turned, the liquid descends and forces out the hydrogen with considerable pressure. The acid, on rising within the lower chamber, again comes in contact with the zinc, and again causes the gas to be generated, and thus, if the apparatus is properly constructed, the hydrogen is supplied under pressure and as fast as it is consumed (Fig. 3).

Fig. 3.

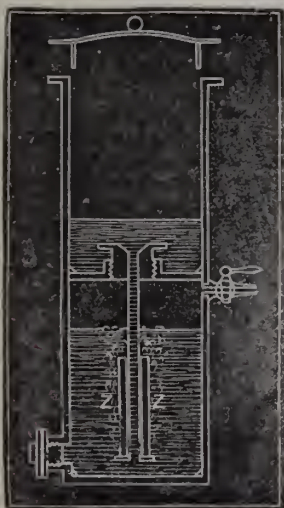

The hydrogen may also be generated in a glass Woulfe's bottle, and be stored in a gasometer, or gas bag, till wanted, or common house gas may be passed into either of these re-

ceptacles, and expelled under any given pressure by means of weights.

Oxygen gas is readily and safely prepared by placing a mixture of two parts of small crystals of chlorate of potash to one part coarsely ground oxide of manganese, into a conical copper retort, which is then closed with a cap or safety valve of vulcanised india-rubber tubing, and connected with the long tube of a wash bottle, for the purpose of freeing the gas from dusty particles or other impurities. The heat of a lamp is then applied, and as soon as the oxygen begins to issue from the short tube of the wash bottle, it is connected by a flexible tube with a wedge-shaped gas bag, as shown in Fig. 4, and so collected and stowed for use.

Fig. 4.

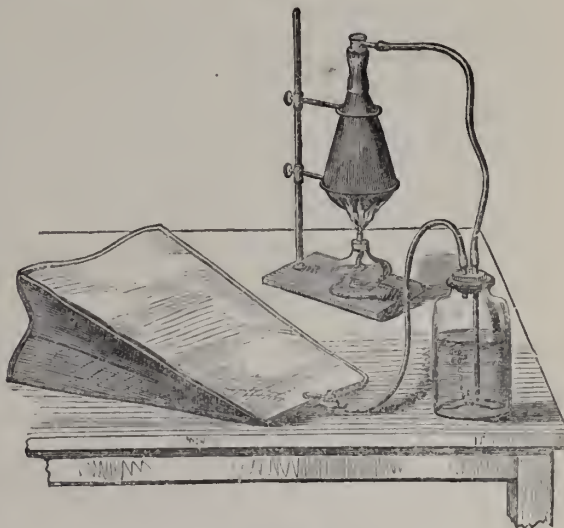

(To be continued.)

Proceedings of Societies.

LONDON PHOTOGRAPHIC SOCIETY.

THE annual meeting was held at King's College on the evening of Tuesday Feb. 3, the LORD CHIEF BARON in the chair.

The minutes of the previous meeting having been read and confirmed, the Viscountess Hawarden and the following gentlemen were elected members of the society:—Messrs. J. L. Wensall, A. Sylvester and W. Austen.

Some pleasing specimens of photography on opal glass were exhibited by Mr. Portbury.

The CHAIRMAN announced, that as no new nominations had taken place at the last meeting, the gentlemen proposed by the council, at the meeting in December, would, in accordance with the rules of the society, become officers for the ensuing year.

The names of the officers for election or re-election would stand as follows:—The Lord Chief Baron as President, Mr. Glaisher as Vice-President, Mr. P. Le Neve Foster retiring from that position into the council; as members of council, Messrs. Henry Pollock, J. Cole, Hennah, Lieut.-Col. Stuart Wortley, and Lord Henry Lennox.

The SECRETARY then read the auditors' report, which congratulated the society upon a more favorable state of the funds than had existed for some years, the excess of income over expenditure being, £32 18s. 0d. The number of new members during the year had been thirty nine, against sixteen during the previous year.

The SECRETARY then read a letter from Mr. Fenton, announcing the award of prizes in the exhibition of the society, with the reasons for the decision at which the adjudicators had arrived. We shall publish this report in our next.

Lieut.-Col. STUART WORTLEY then read an interesting paper on the production of instantaneous pictures of large size, which will appear in our next. After the thanks of the meeting had been given to Col. Stuart Wortley,

The SECRETARY read a letter from Mr. England, describing a method of testing coloured glass for use in the dark room, accompanied with illustrations of the suggestion, consisting of a series of pieces of yellow glass, about two inches square, of different tints. These were arranged side by side between two white glasses, and each piece numbered. A piece of sensitive paper was then exposed for some hours under these glasses, and their respective powers of resisting actinic rays thus ascertained.

Mr. P. LE NEVE FOSTER asked Col. Stuart Wortley what especial benefit he found from the use of the iodide and bromide of lithium.

Col. STUART WORTLEY said it dissolved very freely in alcohol, yielded a clean and good picture immediately after the collodion was mixed, and gave fluidity to the collodion, which rendered it valuable for use with large plates. The collodion was moreover very sensitive and stable, not changing within ten months, which was the longest time he had kept it.

Mr. VERNON HEATH, expressed a conviction that the great future of photography largely depended upon the production of instantaneous pictures, and the subject was therefore peculiarly interesting. He wished, therefore, to ask Col. Stuart Wortley whether he had taken any instantaneous pictures in this country, or only in the light of Italy. He should also like to know what means were used to secure instantaneous exposure. Every one who had seen the beautiful pictures in the exhibition, must be very anxious to obtain any information which might enable them to take such pictures in this country. He would also add, that he had listened with great interest and pleasure to the remarks in the paper on printing. He was convinced that no one could so fully understand the qualities of a negative and the results it ought to yield, as the photographer who had produced it; the mere printer, unfamiliar with the scene, and the effect which would best render its character, could not produce the prints best for the purpose; and he thought it would be doing a great deal of good to urge the importance of every photographer printing his own negatives.

Colonel STUART WORTLEY had not practised instantaneous photography in this country; but, from some recent experiments in portraiture, he was led to believe that there was not that difference in the light of Italy and this country which was imagined. In some respects the advantage, so far as landscape photography was concerned, was found in this country. It was very difficult to render distance in Italy, on account of the hot vapour which generally hung over the horizon. The only time when it was possible to succeed satisfactorily was the day following a thunder storm or rain.

The Honourable W. VERNON had found that early in the morning was the best time for landscape photography in Italy. He wished also to add his conviction in confirmation of the remarks of Colonel Stuart Wortley and Mr. Heath as to printing.

Colonel STUART WORTLEY said, regarding his method of exposure, he simply used his hand. It would be noticed that his pictures were fully exposed; indeed, the process was more rapid than the exposure, sometimes a little blurring of moving objects being observed. He wished he had a more rapid method.

Mr. J. W. OSBORNE wished to ask three questions. Colonel Stuart Wortley had referred to a liberal use of acetic acid in conjunction with formic. How much constituted a liberal amount? Second, he asked his reason for using bichloride and iodide prior to the use of pyrogallic acid and silver. He had himself adopted that plan when he found it difficult to get sufficient intensity, but he wished to know what was the object of using it generally, when the opposite method, that of using pyro and silver first and bichloride afterwards, was so much more usual. Third, he wished to know why Dallmeyer's triple lens was used, seeing that an impression prevailed in some quarters that it was slower than the single lens, owing to the number of reflecting surfaces. Was it because of its known freedom from distortion, or because it permitted the use of the full aperture, and thus practically quicker than others, or for some other reason?

Col. STUART WORTLEY used as a rule as much acetic acid as formic acid, but varied according to the temperature and the light, trying a plate in the morning to ascertain. If there were not sufficient acetic acid, the picture flashed out too quickly for control, and about two inches of the plate, where the developer first came in contact, was fogged. By adding more acetic acid the image was a few seconds before it appeared, and then developed satisfactorily. The formic acid aided in giving

amazing detail. Mr. Simpson would remember a specimen he sent over from Naples to him, which especially showed this quality.

Mr. G. WHARTON SIMPSON said the picture in question was one of the most exquisitely detailed pictures he had seen, and of a difficult subject.

Col. STUART WORTLEY said as he intensified his negatives after they were dry, some of them having been taken in Italy and intensified in this country, he found a method of producing an iodide on the surface of the picture prior to the application of pyrogallic acid and silver was desirable, otherwise the negative would not intensify easily.

A conversational discussion on this subject followed, in which Dr. Diamond remarked that he had seen Col. Wortley's manipulations, and whilst the pyro and silver applied to a dried plate would not take at all, nor give intensity, after the application of bichloride and iodide no difficulty was felt.

Col. STUART WORTLEY said, in regard to the question about the lens, he used the triple lens because it covered a larger sized plate more perfectly than other lenses of the same focus which he had tried. He was sorry he had not some of the pictures at the meeting to show, but they were all at the exhibition.

Mr. OSBORNE: Do you think it the best lens?

Col. STUART WORTLEY: I have not found any so good; but I have not tried everybody's lenses. Without wishing to depreciate others, I think it right to state which I have found answered best.

Mr. HEISCH said he had recently intensified six dozen negatives taken in the Holy Land, and had used nothing but pyro and silver. He had found no difficulty in producing intensity.

Col. STUART WORTLEY asked if they were developed with iron.

Mr. HEISCH was uncertain.

Mr. DEBENHAM was in the habit of intensifying with pyro and silver without difficulty. The negatives were developed with iron, using bromo-iodized collodion.

Col. STUART WORTLEY said much would depend upon the amount of deposit to begin with.

Mr. SEBASTIAN DAVIS referred to some experiments he had made with single and compound lenses. Using a stereoscopic single lens and one of Dallmeyer's double lenses of similar focus he found that with an aperture of $\frac{3}{8}$ ths of an inch in the single lens, and $\frac{1}{4}$ ths of an inch in the double lens similar results as regards definition and intensity were obtained. In the exposure the single lens required 10 seconds, whilst the double lens required only 4 seconds. The double lens was the most rapid in the ratio of 4 to 10. Regarding the triple lens, it doubtless gave fine results, but he did not think satisfactory definition all over the plate was obtained with the full aperture; a somewhat small stop being required to secure good marginal definition. In many of Col. Stuart Wortley's pictures the margin was removed by vignetting, so that any defective definition was not seen. On the whole, he was disposed to think that a single lens was more rapid.

Col. STUART WORTLEY assured Mr. Davis that the vignetting was not due to any defect of the lens, but solely for the purpose of producing an artistic picture. Besides, some of the pictures were not vignettted, and he thought that it would be seen in them that the whole plate was well covered. He ought to mention also that the lenses used were only intended for plates 6 by 5, and 8 $\frac{1}{2}$ by 6 $\frac{1}{2}$, whilst his pictures were very much larger.

A communication from Dr. Van Monckhoven on the Theory of Photographic Processes, was then read by Mr. Shadbolt, but elicited no discussion.

The CHAIRMAN proceeded to make some interesting remarks on the practical progress of photography, but confessed that he had been somewhat disappointed that more light had not been thrown on its scientific and theoretical aspects. He thanked the society for the honour they had done him in his re-election. His years forbade the hope that he could much longer till such an office, and hoped the society would not neglect an opportunity of securing more efficient services; adding, however, whilst they might find a more able chairman, one more willing and zealous for the interest of the society they could not possibly have.

The Secretary announced that at the meeting in March Mr. Johnstone, of Birmingham, would read a paper on the Electric Theory of Photography. After some votes of thanks the proceedings terminated.

Correspondence.

NATURE AND CONSTITUTION OF THE FINISHED NEGATIVE.

DEAR SIR,—Permit me to make a few observations in the NEWS upon the discussion of an important topic, respecting which much has been said and written of late, namely, "The Nature and Composition of the Photographic Image." I think the statement of the problem to be solved embodied in this phrase is somewhat vague, and has conducted, in some measure, to give vagueness to what we have read upon the subject in your own and other journals.

Some persons evidently think it necessary to explain the *modus operandi* of the subtle chemical and molecular changes produced by the actinic rays. These they illustrate by divers similes, designed to convey the idea of unstable equilibrium, and pass on naturally to the mode in which the developer acts, thereby involving themselves in the mazes of two most difficult questions, respecting which very little is known, or will be, until inductive reasoning, based upon cleverly devised experiments, and the closest observation, is brought to bear upon them. Now, if photographers confined themselves to the investigation of the dark deposit in the collodion film, or rather made that a separate subject for the present, perhaps some progress might be made; for I quite agree with Mr. Malone, that enough time has been spent on conjectural statements, and what we want now is facts. It appears to me that the determination of the nature of the substance which produces the opacity in a negative is quite within our reach; but it will never be arrived at by speculation alone, which is legitimate only so far as it guides our experiments. I am not about to enter upon this subject in the present communication; but I wish to bring under the notice of such of your readers as occupy themselves with its investigation, a fact which should not be overlooked.

If, after fixing and drying any ordinary negative, but especially one of a black and white subject, such as an engraving, the surface of the collodion film be carefully examined, the transparent parts of the picture will be found to be relatively depressed in a very striking manner. I have been aware of this fact for a long time, and have speculated much upon its probable cause, and the uses which might be made of it, and have also written respecting it long ago to Mr. Hadwich, requesting him to bring it before the Society; but when he received my letter, he had already left King's College. I have never seen a statement of this phenomenon in print, nor any allusion to it; but the idea that it had not been observed before was instantly dispelled by yourself and Dr. Diamond, on my arrival in England in July last. Being therefore known, I certainly am surprised that it has not been put prominently forward as an important item in the consideration of the deposit in the collodion film; for I do not think that any one of the talented men, who have thought and written on this subject, will venture to maintain that it is the actual bulk of the metallic matter in the collodion, which gives rise to the differences in elevation of the transparent and opaque places, a difference by no means so slight as might be supposed.

A copy by mechanical means may be taken of the depressions in any negative, in the copperplate printer's press, or even in one used for lithography, if a sheet of tin foil in contact with its surface be submitted to the necessary pressure. For this purpose, the soft, spurious description of tin foil, largely alloyed with lead, is the best fitted, and some experience and care is desirable if the negative is a valuable one. But I have succeeded in producing from negatives of a variety of kinds many excellent copies on metallic surfaces, in the way I have described, and by other means less satisfactory. Copies of this kind serve to establish incontestably the reality of the depression, which some persons detect with difficulty upon the glass; and to

show that its amount entitles it to serious consideration, I purpose exhibiting a few specimens produced by my method at an early meeting of the Society.

We have frequently been told that one of the advantages collodion offers for photographic work arises from its absolute indiffidence, chemically speaking, to the silver salts. This may be so. I do not now intend to controvert it; but the fact above cited seems to me to make it appear probable that a change of some kind has taken place in the collodion itself, where the light has fallen, and that its condition in such places is not the same as it is in the shadows.

Until lately most of us were under the impression that the white parts of a positive print contained no silver. We took for granted the power of the hypo to break up any uncoloured combinations between silver or its salts, and albumen. Our opinions are now modified, and I draw the obvious moral from the change, and applying it to statements made respecting collodion, object to take its total indiffidence for granted, while I am far from regarding its chemical activity as proved. I am, dear Sir, yours truly,

J. W. OSBORNE.

61, Beaumont Street, Portland Place, W.
January 26, 1863.

Photographic Notes and Queries.

RESIZED PAPER.

DEAR SIR,—Further experience with this paper has led me to the conclusion that a floating of three minutes on the sensitizing bath, if of 80 grains strength, is amply sufficient to give, not only a good, but a brilliant picture. Apologizing for troubling you, I am, dear sir, yours truly,

W. H. WARNER.

Ross, January 16th, 1863.

PHOTOGRAPHIC PIRACY.

SIR,—It has occurred to me that the infringement of copyright in photographs might be prevented by making the sale of photographs, not bearing the name and address of the photographer, an illegal act on the part of the vendor, punishable by fine for each separate sale. If the vendor were thus responsible, he would not venture to sell pirated copies. The actual copier should be liable to a much heavier fine. To "counterfeit" the name of the photographer would of itself be forgery.

I am not aware how far the law, as it exists, may be effectual for this purpose; but, as the evil is so notorious and extensive, I should think there is good ground for getting, if necessary, some such power over the vendor, when the general subject of copyright is reconsidered, as it probably will be, this session.—I am, sir, your obedient servant,

ALEXANDER BASSANO.

February 3rd, 1863.

[We fear it would be difficult to obtain the power our correspondent suggests. We hope that the law as it stands, if vigorously applied, will be found efficient in suppressing the disgraceful piracy which has hitherto been as a cankerworm injuring the art.—ED.]

LEUT.—Light also has an undoubted influence on the growth of some of the lower animals. Animalculæ grow, in water, much more readily in the light than in the dark. If equal numbers of silkworms be exposed in a light room and a dark, many more larvæ will be hatched from the former than the latter. And, what is stranger still, Dr. Edwards found the development of tadpoles into frogs may be entirely prevented by the absence of light. They grow into big tadpoles. Several facts tend to the belief that the human body is greatly amenable to the influence of light. Dr. Edwards found that persons living in caves or cellars, or in dark streets, are apt to produce deformed children; and the workers in mines are liable to disease and deformity beyond what could be accounted for by the condition of the atmosphere. And it has even been affirmed by Sir A. Wylie that in a large barrack at St. Petersburg the cases of disease in those men who live on the dark side for many years are three to one to those on the light side.

Talk in the Studio.

ART PHOTOGRAPHY.—At the next meeting of the South London Society, to be held in the City of London College, Leadenhall Street, next Thursday evening, Mr. Rejlander will read a paper, entitled Rejlander's Apology for Art Photography. Mr. Price, also, will read a paper on the Theoretical Principles of Positive Printing.

PHOTOGRAPHIC COPYRIGHT.—Mr. Sothorn having become a world-wide celebrity, the world naturally desired to have his portrait; and so he consented to sit to Mr. Hering, the eminent photographer of Regent-street, for no less than nine *cartes de visite* representing him in so many highly diverting and Dundrearyish attitudes. These productions, most elaborately and artistically executed, have had, it appears, a prodigious sale. It seems to have occurred to a person named Daniells, a photographer carrying on business in Pentonville, that a very good speculation might be made out of the Dundreary mania, by counterfeiting, or forging, or re-photographing Mr. Hering's pictures, the copyright of which had been duly secured, and notices to that effect affixed to the front and back of each likeness. This disgraceful simulation was ere long discovered. Daniells appears to have sold numbers of the spurious *cartes de visite* at a very low rate; but his tricky trade was brought to a sudden stand-still by a couple of summonses to appear at the Clerkenwell Police Court, there to answer for a wilful and wanton violation of the 26th and 27th Victoria, which punishes the infringement of artistic or photographic copyright in copying or selling any such work of art, without the consent of the proprietor, by a forfeit to him of a sum not exceeding ten pounds and which also provides that all existing copies, repetitions, and imitations, and the negatives from which the photographs have been printed, shall be confiscated. Nothing could be clearer than the evidence which brought home to Daniells the offence of having made use of the original Dundreary for his own counterfeits. The only question was a technical one respecting the Artistic Copyright Act, which requires to be affirmed by some high judicial decision. With a view of fixing the meaning of the law, the sitting magistrate, Mr. Barker, inflicted a penalty of three pounds and sixpence, together with two guineas costs, in order that the defendant might appeal if he so chose. Such a course he has elected to pursue; but if he be wise in his generation he will desist from disputing the decision arrived at. Recent experiences and common sense convincingly prove that there should be as clearly defined and as rigidly enforced a copyright in an original photograph as in an original picture; and if the law we already possess is loosely or vaguely worded, it must be speedily and precisely amended.—*Telegraph.*

To Correspondents.

** WE must again crave the indulgence of a large number of our advertising friends whose announcements are compelled to stand over until next week.

M. W.—Very little is written on the Calotype process at the present day, simply because it is little practised. Dr. Diamond is one of the best Calotype manipulators we know, and you cannot do better than follow the instructions in his article. Those, or the instructions by "Theta" in our own pages, will aid you to produce satisfactory results.

D. A.—We are glad you find the gold and lime bath so successful. We have not used the lens to which you refer, but have heard it well spoken of, and have seen some good work done by it.

SPECLUM.—The film splitting and curling off the plate may be due to several causes, but the condition of the collodion is most frequently the primary cause. Some kinds of pyroxyline have an especial tendency to this defect, and weak solvents, containing too much water, materially tend in the same direction. Dirty plates or damp plates will also cause it. When the tendency is found to exist, be very careful that the plate is clean and quite dry; see that the film is well set before immersion; be very careful to avoid under-exposure, as under-exposure and prolonged development will bring it about if the slightest tendency exist from other causes. When this result is feared with a good negative, pour a solution of gum or albumen on the film before it dries, and varnish afterwards as usual.

G. F. P.—See answer to "Speculum." For your printing bath, agitate it with kaolin, and filter.

MADDER BROWN.—You may of course obtain good photographs by purchasing published pictures, but as this would be a somewhat expensive mode of getting prints merely to practise colouring upon, you will doubtless be able to procure some on moderate terms by applying to any professional photographer, who generally possesses spare prints.

EXCELSIOR.—The system of prize-giving generally stimulates exertion; but we fear that in connection with the Exchange Club it would involve some

difficulties, and would certainly increase the responsibility and already invidious duties of the referees. Your letter shall, however, be handed to them for consideration. The date and hour of exposure should always be appended, as well as the time, lens, stop, and other particulars.

A. BEGINNER.—The most common cause of a sandy surface is supersaturation of the bath with iodo-nitrate of silver. See an article on page 597 of our sixth volume, the number for December 12, 1862, and on page 590 in the same number. A bath which has been boiled down will be very likely to give it. To remove the cause, dilute the bath with an equal bulk of distilled water, let the solution get as cold as you conveniently can, and then filter. The hurning of gas is not desirable in a dark room, but it is not likely to cause the sandiness referred to.

M. M. D.—A square inch of coloured glass is sufficient for our examination. We do not require any fee for the examination, but have pleasure in undertaking it for our readers. 2. Doubtless you can purchase a good iron negative of almost any professional photographer. If you do not know any, we can furnish you with the names of some.

AMARANTH.—The lens you have procured is probably the best you could possess for your purpose. 2. It is not so quick as a portrait lens; but as quick, or quicker than other landscape lenses. 3. We prefer an iron developer for all purposes. We shall always have pleasure in helping you by our advice.

G. H. MARTIN.—The card sent is very round and brilliant. The printing is especially fine, and the tone good.

J. W. P.—The letter was posted with the proper address added. **QUERCUS.**—Printing by development has not generally been successful with albumenized paper, but it can be done. The albumen must, in such case, contain a bromide, or bromide and iodide, as well as a chloride. The process will then be similar to that on plain paper. 2. The copies to which you refer are very diminutive, a bust about the size of a shilling mounted on the ordinary sized card. A number of prints are probably copied at once, forming one large negative. The results are very poor; but, taking everything into consideration, we should not like to produce them at the price.

W. WARRINGTON.—The size of the condenser commonly used in the solar camera is nine inches, and the focus eighteen inches.

A THREE MONTHS SUBSCRIBER TO THE NEWS.—For a first attempt your prints are promising. They all require printing deeper, and all the negatives have a little too much top light, which causes heavy shadows under projecting features. Cover more of the skylight immediately over head, and get a little shadow on one side of the face. No. 1, the face is flat from over-development or over-intensifying. No. 2 is better in this respect, as also is No. 3. No. 4 is flat in the face from too much light all round it, and a little over-intensifying. With care and perseverance you will succeed. Let us hear of your progress.

A PRINTER'S ASSISTANT.—You have used too large a proportion of alcohol and too much silver. Nitrate of silver is very sparingly soluble in alcohol, and when you add one-third of its entire bulk of alcohol to an 80 or 100-grain solution, the probability is that the alcohol will float on the denser fluid, and even if well stirred up, they would not mix without precipitating some of the silver, and hence the mottled effect of your prints. As a remedy, add an equal quantity of a new 60-grain solution. 2. Filtering water only removes matter in suspension; it does not get rid of chlorides, carbonates, &c., and therefore does not form a substitute for distilled water where the latter is imperatively required. 3. Soap and water should not be used for washing prints, the soap is useless and injurious. 4. We have not used magnesia in a toning bath. It might be used, but we don't know of any special advantage in its use. 5. About a quarter of an hour is the time required for fixing. If the paper be thick, the bath weak, or the weather cold, a little longer may be an advantage. 6. We use methylated spirit for almost every photographic purpose, instead of pure spirit without disadvantage. 7. Intense negatives and deep printing are requisite in order to ensure purple or black tones. The acetate of soda bath will give fine purple tones, but the lime bath gives black tones most readily.

GEORGE GUYEN.—We regret to state that the Almanac is out of print. We printed of this year's issue a very large number in excess of what had been done before, being warned by the experience of last year, at least 500 applications having been made after the work was out of print. Our calculations have, however, been at fault, the demand having again exceeded them.

ALPHA.—Two quarter-plate portrait lenses may be used with advantage for the production of stereoscopic pictures. 2. A fallacy used to prevail to the effect that so much as a passing gleam of light would ruin a nitrate bath. We have never experienced any evil result from such a cause. It is as well, however, to keep the bath generally in the dark; any evil which could result would arise from the presence of organic matter in the bath, which light would tend to reduce. 3. It entirely depends upon the mode of intensifying whether it may or may not be done in daylight. With bichloride of mercury, sulphide of potassium, &c., you may work in daylight; with pyro and silver, it is better to work in yellow light, as white light, acting upon the silver, will soon make the pyro and silver turn turbid, and will sometimes cause reduction on the shadows, and fog.

XENOPHON.—The stains on your negatives arise from the use of an energetic developer, which you do not contrive to make cover the plate at once in one even wave. Until you get more skill in covering the plate with the iron solution at one sweep, use it a little weaker, add a little more acetic acid, and also a little more alcohol to prevent the solution running from the edges of the plate in greasy lines. 2. A little more exposure would have improved the negatives; and, with a weaker developer and more acid, you would have less risk of reduction on the shadows. 3. We not know much of the lenses you name, but believe them to be pretty good for low-priced lenses.

** A large number of articles in type, and answers to correspondents in our next.

Photographs Registered During the Past Week.

- MR. WILLIAM MAYLAND, Cambridge,**
Portrait of late Jonas Webb, Esq.
MR. JOHN INSKIP, 10, Granby Place, Queen Street, Scarborough,
Two Cartes de Visite of the Rev. S. Wilkinson, Sheffield.
MR. JOHN WEBBER, Taunton, Somerset,
Three Portraits of A. W. Kinglake, Esq.

THE PHOTOGRAPHIC NEWS.

Vol. VII. No. 232. — February 13, 1863.

CONTENTS.

	PAGE		PAGE
Spirit Photographs	73	Prizes at the Photographic Exhibition—Adjudicators' Report...	81
The New Globe Lenses	74	Remedy for Cracked Varnish. By H. R. Nichols.....	81
Enlarged Negatives	75	The Application of Photography to the Magic Lantern Educa-	
Printing Difficulties. By a Photographer's Assistant	75	tionally Considered. By Samuel Hightley, F.G.S., F.C.S. ...	81
On the Production of Instantaneous Photographs on Large		Correspondence.—The French Photographic Exhibition ...	82
Plates. By Lieut.-Col. Stuart Wortley	76	Photographic Notes and Queries	83
On the Manipulation, Developing, and Intensifying of Negatives.		Talk in the Studio	84
By James Ewing	76	To Correspondents.....	84
Theory of the Photographic Processes. By Dr. D. Van Monck-		Photographs Registered during the Week	84
hoven.....	79		

SPIRIT PHOTOGRAPHS.

WE feel that some apology is due to our readers for gravely occupying their attention with what we now do not hesitate to style a pitiable delusion originating in shameful fraud or mischievous trickery. Our business is not, however, with the general claims of what is termed "Spiritualism," but with a phase of it in which our own art is prostituted to purposes of imposture, and which we feel called upon to lay fully before our readers, if not to denounce. The chief details have already appeared in our pages, and, as no new facts have transpired, we shall not exhaust the patience of your readers by a repetition of evidences similar to those already published. The faith of photographers in this country has, however, been challenged on new ground. Copies of the photographs containing the alleged spirit-portraits have been announced in our advertising columns for sale in this country, three for three and sixpence, in sealed packets, like some other matters of more than questionable character. In addition to the evidence thus to be derived from sight, the *Spiritual Magazine* claims especial attention and credence for a letter from Dr. H. T. Child, of Philadelphia, who is stated to be well known to "many in this country as a man of science, and a clear philosophical thinker." We demur, however, entirely to his science and philosophy, as developed in the letter in question, for the reasons we shall lay before our readers.

Dr. Child, at the opening of this letter, states that he had been informed that "the learned philosophers who constitute the American Photographic Society had solemnly resolved that the spiritual likenesses are a fraud and gross deception;" he then adds that this led him "rather to infer that these pictures were real because of this decision!" The fact that a body of scientific gentlemen, with no possible object before them but the truth, having examined a subject on which they were pre-eminently well qualified to form an opinion, and pronounced it a fraud, rather inclines this "philosopher" to believe in its truth, and in this spirit he proceeds to investigate the subject. He informs us that he is aware of the modes in which the spirit photographs might be simulated, one of which is to place another negative in contact with the sensitive plate, already containing a latent image of an actual sitter, and allow the light of a lamp to pass through the negative. So far so good. But the doctor then proceeds to illustrate his character as a "man of science," by informing us that he has seen a photograph so produced, and that it was distinguishable from the genuine spirit photograph by having "a very marked yellow tint, the result of the artificial light of the lamp!"

With these two specimens of the doctor's knowledge of facts and mode of reasoning upon them, his "science" and "philosophy," we presume our readers will be content. One word more, however, since it bears on the theory of photography, and introduces ideas doubtless new to our readers. Some of the doctor's spiritual visitants have communicated

to him the theory or *modus operandi* of these spirit portraits. Here it is:—

"There are three forms of matter. First, tangible matter; second, the imponderables, well known to science as heat, light, electricity, magnetism, the Od force and the life principle. These become more refined in the order in which I have named them, and thus approximate toward the third realm of matter, which constitutes spirits, and the home they dwell in, in the spiritual world. Photography, or the art of printing by light, is the most spiritual of all the arts, and by it any substance that is sufficiently dense to set in motion the rays of light, may have its form and character printed on the plate, being received there by the delicate and perceptive chemicals which are used. But spirit forms are so much more refined than light, that they cannot set in motion or reflect its rays. To do this, they require the aid of the life principle—the Od force—magnetism and electricity. These may be obtained from certain mediums, and the atmosphere around them; and when thus obtained and properly placed, either around a spirit form, or combined and formed into such a model as to represent the form itself, either of which will be enabled to set in motion the next form of matter, which is light, and print an image upon the glass. It does not require as much light to print this as it does to make an image on the retina of the human eye, and hence these forms are not visible. This model process is the one which will be first introduced, and hence the forms of spirits and objects will not be very perfect."

One or two words on the "spirit" portraits sent to this country and advertised for sale. When we saw the announcement, we called upon the publisher and asked to be permitted to see the pictures in question. We were informed that strict instructions had been given that no one was to be permitted to see them without purchasing. They were in sealed packets, and could only be seen on disbursing three shillings and sixpence. As these instructions emanated from the proprietors of the *Spiritual Magazine*, who have undertaken the speculation of getting up these pictures for the English market, we were scarcely so much impressed with their desire to promulgate what they believed to be spiritual truth, as with their anxiety to obtain material cash. However, we purchased the packet, and although we were prepared for imposture, we were altogether confounded by the barefaced humbug revealed to us.

The first picture contains a portrait of Mumler, the "medium and photographer," standing with his hand on a chair. In the printed description at the back it is stated "in the chair sits a half-defined female form," and that "this was at once recognized as a deceased relative." The half-defined female form is simply and palpably, to the eye of any experienced photographer, the smudgy trace of a former image on an imperfectly cleaned plate, not sitting on a chair, but near it. She is attired in the ordinary costume of the material world as worn in the nineteenth century, and sitting in the conventional position, with one arm on the table holding a book and the other laid across a lap, as doubtless Mr. Mumler is in the habit of posing young ladies. It is such an image as almost every photographer of any practice has occasionally been troubled with, the persistency

of the image on some samples of glass being very singular. An eminent photographer informed us the other day that he had a plate which every time it was used gave traces of the portrait of the late Prince Consort, which had once been taken on it; and there are various similar cases on record.

The second picture is a portrait of Mr. Alvin Adams, stated to be known as the great express agent of America. By his side and partly mixed up with his figure, is the smudgy and indistinct image of a boy reading, which is stated to be recognised as the portrait of a nephew who has been dead a few years. The same general remarks apply to this as to the preceding picture.

The third is a portrait of Mr. Luther Parks, of Boston. The "spirit" figure here bears the evidence of intentional imposture. The other images are as we have stated evidently the result of ill-cleaned old plates, and may have been produced by accident, and afterwards presented as spirit photographs in joke until, in the eyes of credulous persons, they assumed the aspect of supernatural visitations. The trick "taking" must be repeated and improved upon; and in the picture of Mr. Parks we have an illustration of the attempt. Here a figure is introduced bearing some resemblance to the conventional and time-honoured ghost; it is robed in flowing white drapery, with something like a nimbus, or it may be a fancy night-cap above its head; one arm is extended and holds something like a wreath which is offered to Mr. Parks, who appears quite unconscious of the favour. The general position and aspect of the figure reminds us of allegorical paintings of Victory crowning heroes. This figure, we are informed, is recognized by the family as a "strong" likeness of a deceased nephew. Now, as the face in the picture has not a trace of a feature, but is simply a round white patch, without any indication whatever of the human face divine, rather resembling the white paper dolls cut out occasionally for children in the nursery, we can only come to the conclusion that it was the most extraordinary "nephew" we have ever seen, or that "the family" are considerably more imaginative than the Yankee horse which, having green spectacles put on, fancied he was at grass when he was eating deal shavings.

Seriously speaking, we feel very indignant that our art should be brought into disrepute by being made subservient to such an impudent trick. We are told in the *Spiritual Magazine* that the whole is a matter of evidence, meaning testimony, and not of probability or theory. We reply that there are some things which are not believed on testimony, and that there is some testimony not worthy of credit. We should not believe a man who informed us that the moon was made of green cheese, although he told us that he had been there, and subsisted for a month on its cascos products. These photographs present internal evidence of their mundane source, stronger than all the testimony as to their spiritual origin. And we protest against the blasphemy offered to man's spiritual nature, in attributing these abortions to such a lofty origin.

We are somewhat amused to find at the conclusion of the article in the *Spiritual Magazine* the following remarks: "of course the *Photographic Journal* of London is true to its instincts, and denounces the whole as a shameful imposture," &c. Now, as the *Photographic Journal* did not offer a single comment on the subject, we presume that the *Spiritual Magazine* is confounding us with our esteemed contemporary, and as a challenge follows, we feel bound in fairness to take up the gage. "We invite these gentlemen," says the *Spiritual Magazine*, "to produce likenesses of the deceased relatives of their sitters, whom they have not previously known, and without the collusion of their sitters, in the presence of honest and experienced investigators, who shall not be able to detect the imposture." When the editor of the *Spiritual Magazine* will furnish us with sitters, and investigators who will be willing to accept patches of white paper without a trace of feature, such as the image of Mr. Luther Park's nephew, as "strong likenesses," we shall unhesitatingly produce any quantity of such likenesses.

THE NEW GLOBE LENSES.

We have recently had opportunity for a hasty examination of some of Harrison's new globe lenses, regarding which extraordinary statements have been made as to the amount of angle they included. We knew that some of Harrison's lenses were very good, having used one we purchased in New York for years. But we must confess we were disappointed in these; not so much at any special faults in the lenses as in the discrepancy between their actual qualities and those claimed for them. It was stated that the new lenses would include an angle of 90° on a flat plate; and that they were very rapid. It has been more than once stated, the stereo lens of this form having a focus of two inches and a half, would produce a picture of five inches square. We had no opportunity for any very accurate examination or trial, but we will record the result of a hasty inspection.

The combination consists of two meniscus lenses placed with their convex surfaces outwards, and so arranged as to form segments of a perfect sphere. They naturally present a somewhat unusual appearance, and are mounted in what appeared to us an unnecessarily heavy and clumsy bronzed mount. The stops, five in number, are fixed in the centre, all being in one plate, each one in succession being brought into position by the rotation of the plate.

The stereo-lenses have a back focus of $2\frac{1}{2}$ inches, the equivalent focus being about $3\frac{1}{2}$ inches. The circle of light produced is about five inches in diameter, but it is very unequal in intensity, being bright in the centre, and falling off considerably towards the edges. The extent of good definition, however, even with a small stop does not exceed the size of a stereoscopic plate, or about $3\frac{1}{4}$ inches square. The first fact which struck us was, when using the largest stop, the want of a crisp, fine definition, or precise focus anywhere, arising from the existence of a considerable amount of spherical aberration. To secure good definition a very small stop was necessary; and as with the largest stop the amount of illumination was very small, the use of the lens is necessarily limited to subjects permitting long exposure.

For the purpose of obtaining a comparative view we mounted one of the globe lenses and one of Dallmeyer's new stereo lenses on the same camera, so arranging them that the image of both, when in focus, fell on the same plane. With the globe lens we used the largest stop, which is about a quarter of an inch in diameter; with the Dallmeyer a stop of about three-eighths of an inch. With these stops the amount of illumination was nearly equal, but a little in favour of the English lens. The definition in the globe lens was very much inferior everywhere. It was a dull, foggy day, requiring a wet collodion plate requiring an exposure of about a minute and a half. The image given by the Dallmeyer lens was sharp and crisp and well made out, that by the globe lens was altogether fuzzy. In the latter there was, however, the considerable depth of definition which arises from spherical aberration. The margin of the plate also showed considerable astigmatism.

We also made a hasty examination of one of the larger lenses, the back focus being 8 or $8\frac{1}{2}$ inches. We did not try this lens, but examining its image on the ground-glass we observed the same want of crisp definition as in the smaller lenses. The equivalent focus was about 11 inches; the circle of light included about 15 inches, or a little under. A Dallmeyer's No. 1 triple, with equivalent focus of a fraction under 8 inches, gives a circle of light of 12 inches, showing the extent of angle included decidedly in its favour.

For instantaneous, or even ordinary rapid work, these lenses appear to be altogether unsuited; and for ordinary stereoscopic work they have the defect, incident upon a very short focus, of giving a very violent perspective, or rapid convergence of the lines. But as they give perfectly straight lines, they will be occasionally useful for archite-

tural work in confined positions where a very short focus becomes valuable. Thus for interiors they may occasionally be useful, their depth of definition becoming a valuable quality, especially if the amount of illumination will permit the use of a small stop, and thus secure sharpness. For general use, however, they are decidedly not equal to some of the recently invented lenses made by English opticians.

ENLARGED NEGATIVES.

THE prints from enlarged negatives exhibited by Mr. Alfred Harman, have excited much interest amongst photographers as being much finer than it was believed possible to obtain by such a method. The principle and the method of working have been often described in our pages; nevertheless, a few words from Mr. Harman will, doubtless, interest many, and we have asked him for details of his manipulation. Here they are:—

"Dear Sir,—In compliance with your request, I send you a few particulars of the method used by me to enlarge negatives.

"The negatives most suitable for enlarging are those which have received a very full exposure, but have not been sufficiently intensified for ordinary printing purposes. But by judicious management it is possible to get very fine results from negatives which have been taken expressly for printing from. The enlargements exhibited in Suffolk Street by me were enlarged for negatives which had been used for printing a large number of copies. I mention this to show what can be done by this method.

"I will now proceed to describe the apparatus I employ; but to save any description, I have only to refer your readers to some numbers of the PHOTOGRAPHIC NEWS, which appeared a month or two back, where Mr. Samuel Fry described a method of enlargement he introduced for his own practice. My apparatus is identical in principle with his, and I here take the opportunity of thanking Mr. Fry for his very ingenious contrivance, and the liberal courtesy with which he has made it known.

"Now for a few words upon the process. I need not mention that the small negative must be *perfectly sharp*, if not, the loss of sharpness apparent in the enlarged negative will be very great.

"The transparency must be of the same photographic value as the small negative; that is, there must not be any very great contrasts, or the large negative will differ.

"I generally take the transparency a trifle larger than the small negative, but that is a matter of not much importance.

"It is better not to varnish either the original or the transparency, as there is very often a quantity of minute particles in the varnish which do not show in the small negative; but, when enlarged, the effect is, of course, the same as putting them under a microscope. I do not mean to say a good enlargement cannot be made from a negative that has been varnished, but it is better when they are taken with the view of having them enlarged, not to varnish them.

"For large plates, it is necessary to have a support in the centre, while the collodion is being poured. I have a ball and socket arrangement, which I find answers extremely well; the same stand can also be used for developing.

"The bath I employ for large plates is a large deep tray, with about four inches at one end covered, so that when tilted to that end, the well formed will hold the solution. Four pegs stand out from the bottom to support the plate, and prevent its touching the solution, until the bath is lowered to the vertical position, when the solution flows evenly over the glass.

"The development, fixing, &c., are the same as used for ordinary wet collodion.

"In conclusion, I must remark, that it is *positively* necessary to have a room fitted expressly for the purpose, and used for that purpose alone.—Yours very truly, ALFRED HARMAN."

PRINTING DIFFICULTIES.

BY A PHOTOGRAPHER'S ASSISTANT.

WHEN the system of alkaline toning was first introduced, it was generally considered that excessive alkalinity was essential to secure satisfactory results, and quantities of soda, varying from 5 to 10 grains to the grain of gold, was recom-

mended, without one thought being directed to the diversified character of various samples of the tetrachloride of that metal prepared by different makers. The existence of this salt as a tetrachloride was perfectly understood, but the ever-changing quantities that may be traced even in samples prepared by the same maker was considered a matter of too little importance for investigation, and here lay the root of the many failures that characterised toning operations at the period before alluded to. Happily, patient, untiring observation and research have been, and still are, directed to this subject, and we now understand the necessity of avoiding excessive alkalinity in our toning solutions; for under such conditions toning operations may be pronounced a tediously uncertain process. It should therefore be remembered that what I have termed a decidedly alkaline bath must not be taken in its chemical meaning, but rather that condition when the free acid, introduced with the gold, is neutralised by the soda leaving a trace of the liberated carbonic acid, whose presence can only be detected when the litmus paper is in a perfect condition as a testing medium, and I once more emphatically repeat where heat is employed in the manner I have recommended, except a trace of free acid be present, toning action will prove too slow for commercial purposes. There would appear at first sight a striking analogy between the toning and linen bleaching operations, more especially when chloride of lime is employed in the latter process, the operation of each being hastened by the presence of a free acid; the lime in this case liberates chlorine in favour of the acid, but this explanation would not hold good in toning operations, for the fact of gold remaining in solution in the presence of large quantities of free acid, through whose agency it resists decomposition, proves that the acid can exercise no influence in promoting or producing decomposition. But from the facts we have enumerated it is obvious that it has a strong tendency to increase the bleaching powers of the chlorine by directing its action to the surface of the paper and preventing its combination with the soda, as it is wont to do when this substance last named is added in quantity sufficient to overcome the influence of the acid. It is a judicious observance of this bleaching process that enables the printer to secure satisfactory results, as its duty is to prepare the way for the gold. The operation of toning action may, in some respects, be compared to the electro-gilding process, but moved by a power entirely different in its composition, whose nature in the present state of chemical science is but imperfectly understood. For convenience sake we call it affinity; at all events, it is not electricity, for it is a well proved fact that a current of the electric fluid passed through or brought into contact with water containing chlorine, will, by its decomposing action on the water, produce hydrochloric acid, the chlorine uniting with the liberated hydrogen, thus forming the acid named; so that a bath would become more and more acid as toning proceeded. That such is not the case may be easily proved by any person who may feel an interest in the subject.

In the absence of a diagram, we may endeavour to explain our modified views of toning action as follows:—Chlorine entertains a great affection for soda, and would willingly fly to its embrace, but ere she can approach near enough to do so, acid steps between, and combining their forces together, they attack the surface of the paper, thus preparing it for the reception of the gold, and atom after atom is attracted and deposit themselves on the spots thus prepared. If the surface of the paper is not perfectly free from the unreduced, or, at all events, unstable nitrate, it assumes a false colour that dissolves out in the hypo bath; and the same results follow when chlorine is liberated in large quantities, a false colour is produced without a proportionate deposit of gold. We have, therefore, two extremes to avoid, an excessive alkaline, or acid conditions. As a rule, the larger the amount of chlorine the greater the quantity of soda required, and the greater the amount of chlorine liberated by heat, the stronger the necessity for free acid, the quantity being

regulated by the amount of reduction required. Having now said as much as is necessary on the treatment of highly albumenized papers, I shall proceed to treat on the lighter samples, which, with a few words on the numerous failures produced by the agency of water, I shall bring this paper to a conclusion.

(To be continued.)

ON THE PRODUCTION OF INSTANTANEOUS PHOTOGRAPHS ON LARGE PLATES.

BY LIEUT. COL. STUART WORTLEY.*

I SHALL begin by mentioning that, in the short paper I am about to read to you, I shall avoid as much as possible entering into details of manipulation, &c., all practical men having their own way of working.

I may, however, start by impressing upon every one the absolute necessity of clean plates, both for the sake of avoiding marks in the original negative and to guard as much as possible against loosening of the film during the intensification. The collodion I have been in the habit of using is very alcoholic, the following being the proportions:—

Ether	1 oz.
Alcohol, 802	2½ oz.
Iodide of lithium	15 grs.
Bromide of lithium	6½ grs.

or rather more than double alcohol to ether, between 4 and 5 grs. of iodide and 2 grs. bromide to the ounce of collodion. The pyroxyline is first steeped in the iodo-bromized alcohol, and the ether then added. The quantity of collodion varies very much in different samples. I thus obtain a very fluid collodion, which I find a great advantage in coating large plates where a very even film is required, and in all instantaneous pictures where there is much sky.

The utmost precautions must be used to avoid streaks, spots, or stains of any kind. This is one of the great difficulties of working out of doors. I have lost many good negatives by accidental spots from dust, and such unavoidable causes.

The silver bath is made from Hopkins and Williams's pure recrystallized nitrate of silver, 35 gr. to the ounce. I iodize by leaving a couple of coated plates in the bath for several hours.

I then find it necessary to add from 2 to 3 drops of pure nitric acid to the ounce of bath. The more bromide in the collodion, the more nitric acid, I find, is required in the bath. I leave the plate rather longer in the bath than I should were I using simply iodized collodion, as I find the maximum of sensitiveness takes longer to produce with a collodion containing much bromide than with a simply iodized or lightly bromized collodion.

I drain very carefully, and place blotting paper all along the bottom of the plate when in the slide.

My pictures in the Exhibition are taken with Dallmeyer's triplet lenses, and usually with full aperture,—necessarily so when facing the sun, as any diaphragm in the lens produces rings on the plate, when the sun shines into the lens.

My developer I make as follows:—

Sulphate of iron	20 ounces
Distilled water	120 „
			Dissolve.	
Acetate of lead	0½ ounce
Water	5 ounces
			Dissolve.	

Mix the above solutions, and when the precipitate has all settled, decant off very carefully. Add—

Formic acid	5 ounces
Acetic ether	1½ „
Nitric ether	1½ „

* Read at the London Photographic Society, Feb. 3rd.

This I keep as a stock solution, and filter off as much as I require for use at a time, adding acetic acid in proportion, according to the temperature of the weather and the class of picture required. The developer should move freely over the plate, and should remain on the plate some seconds before any sign of the picture appears. As the acid loses its restraining power, the iron acts, and the result is a simultaneous action over the whole plate, and the picture flashes out all at once. You will have noted that the developer is a very powerful one, and I use a very liberal amount of acetic acid as a restraint to the energetic action of the iron and formic acid.

I keep the developer on the film till I have obtained the necessary detail, and then, washing the plate very thoroughly, bring it home in a grooved box, to be fixed in the evening with a weak solution of cyanide of potassium. (Many of my negatives were taken in Italy, and brought home, after fixing, for the intensification to be done in England.) The edges of the plate must be carefully varnished, and the film moistened with distilled water. A saturated solution of bichloride of mercury is then poured on, and poured off as soon as the film has taken the proper colour, on which, after a good washing, a five grain solution of iodide of ammonium in water is poured on and off till the desired depth is attained. I then use two solutions composed as follows:—

1. Pyrogallie acid	12 grs.
Water	1 oz.
2. Citric acid	50 grs.
Nitrate of silver	10 grs.
Water	1 oz.

Pour a few drops of No. 2 into No. 1, and pour on and off. The negative can now be made to assume any depth you may require.

If you have a negative from which you desire to print vignettes, keep the negative tolerably transparent. If you intend to print your negative to the edges, see that it has force conjoined with softness. Many a negative, which is too transparent to give an effective print if printed to the edges, will give a beautiful vignette.

Every one should print from their own negatives. Taste and knowledge are shown as much in the printing as in the production of the negative. Many amateurs who produce moderate negatives send them to professional photographers to print, and thus obtain the taste and talent of another man in the production of the pictures, which they then speak of as their own. This is not, in my opinion, at all right, as the printer certainly deserves to share the credit of the finished picture.

I use, for printing, a silver bath of 100 grains to the ounce of water, acidified with citric acid; and use as toning-bath a solution of chloride of gold and phosphate of soda, of which I keep a large quantity in stock, and prefer to use some weeks old. I fix in fresh hyposulphite of soda, and mount the finished picture with fresh starch.

ON THE MANIPULATION, DEVELOPING, AND INTENSIFYING OF NEGATIVES.

BY JAMES EWING.*

In looking over the papers read before the members of the late and present societies, it is a strange fact that we have never discussed the above important divisions of our chemically pictorial vocation, although, in point of routine, they should have had precedence of our papers on printing, toning, &c. But should the disquisition on the heads proposed for your consideration prove as successful in eliminating general good to the profession as discussions on some of the papers previously read, we shall not be sorry in passing the evening conversing together.

The enthusiasm arising from the beauty, and wonder excited in the versatile French mind, and, indeed, that of the world, by the introduction of the Daguerreotype to the Academy of

* Read before the Glasgow Photographic Association, Feb. 5th, 1863.

Sciences, in Paris, by M. Arago, had not yet reached its acme before the celebrated Mr. Fox Talbot had forwarded for the inspection of the members of that august assembly his sun-made Calotypes: dingy they might be when compared with the brilliant Daguerrotypes, but rich in that promise which M. Bist almost prophetically conjectured, that from those murky shades, with certain modifications, should yet spring the beautiful pictures of to-day.

Whilst admitting the beauty of the Daguerrotypes, its salient points could not be hid: these were principally the danger attendant on the accumulation of plates, &c., used in the mounting of the pictures, the inconvenience of binding them into suitable forms for publication, or other art purposes, as also the objectionable reversion of the image. The Calotype, then, first presented to the photographer a medium by which he could produce, in a kind of way, copies from his first impression; but whilst it pointed to the possibility of overcoming the difficulty, it did not entirely succeed; and, until the introduction of albumen and collodion on glass, nothing of a presentable photograph on paper could be obtained. On the adaptation of Mr. Talbot, however, depended our after success in the production of the negative, his task being to impregnate paper with the salts of the elementary substances used by Daguerre in the production of his image, viz., iodine and silver. The formation of a negative on such paper is the high honour due to Mr. Talbot, but not for the discovery of the latent image, or the agent for development thereof: to give that gentleman such honours would be gratuitously bestowing on him that esteem which legitimately belongs to others, though to Mr. Talbot we are really indebted for our first approach to the negative. But it is still a nice question, which must be decided sooner or later, whether Niepce or Daguerre first produced by a lengthened exposure an apparent image on a sensitive surface, which, by a shorter exposure, was capable of holding the image invisible till developed by some other agent, or, in other words, how was the latent image discovered. After the introduction of glass and collodion, it must be remembered the many difficulties that had to be encountered, producing the negative, the great feat being how to intensify the positive. In a paper read by Mr. Brown to the old society, and one by myself on the positive process, we glanced at the obstacles the amateur and professional had to contend with in their pursuit of the art, as also the introduction of the different formulas, by which we arrived at the production of good pictures on glass; but whilst we were practising successfully and openly the glass process, we were at the same time quietly studying how to intensify. I remember our old daguerrotypes mercury boxes being converted into pans, for the fuming of the positive with sulphur, just as the milliner's girl introduces her idol straw bonnet to be whitened, only ours was the reverse process, it was with the intent to blacken our idol. Having glanced at the discovery and discoverer of the negative and positive from the negative on paper, I take this opportunity to remark, that in an art like ours, where so many differing points are, as it were, brought to a focus, individual effort, such as it may overcome, is brought to a stand-still, and he who would prove a practical and successful photographer, must not work alone, but by a methodical arrangement, to harmonise all these points involved in the art, that step by step each particular part of the process shall be executed with that precision and care which photography demands, the neglect of which in the slightest instance casts a shade over the fair face of the delicate creations. When we consider the multiplicity of operations through which a photograph passes in these days, and the nicety and delicacy with which those operations must be performed, can we wonder that individual effort, however energetic, could successfully compete with an institution regulated by a comprehensive division of labour, where every hand skilled in its own set part executes faithfully the task allotted it without constraining or forcing? Certainly not; and hence, those establishments where this particular is most stringently observed, in America, France, or Britain, have been the most successful, both as regards beauty of result and honourable remuneration. It is important, then, with an eye to the perfection of result, that the manipulation of the negative shall be conducted in as careful and deliberate a manner as possible. This general head involves a great many nice points, more than any casual observer would suppose: the kind of glass best suited for the basis of the negative; the temperature (an important feature); at which the suite of photographic rooms should be kept; the light in the glass-house, and more particularly the colour and quantity of light admitted into the sensitizing

room; the quantity of the silver bath; the strength of the same; whether the pure nitrate in solution or saturated with bromide or iodide; whether alkaline, acid, or neutral; how to strengthen when weakened; method of pouring on the collodion, setting, placing in the silver bath, time of immersion of in the same; draining, placing in the dark slide, and time of exposure.

The kind of glass to be used; on this head a variety of experiments exist, as to whether colourless plate, patent plate, flatted crown, or common glass, is best suited for the purpose. The weight of opinion in the matter preponderating in favour of the patent plate, the colourless glass being objected to on account of its softness, difficulty of getting its free from scratch, and its tendency to absorb damp under the varnished film, producing cracking in the negative. Flatted crown is often used as successfully as plate, but is more subject to break, on account of its thinness, and more difficult to clean; all the objections to the other qualities are labelled against common sheet, and yet I must say I have seen good negatives taken on all these kinds of glass; but there is no doubt to be entertained against the fact of plate glass being the glass for negative purposes. In cleaning the plate the old and unsurpassed system of steeping it in a dilute solution of nitric acid and water, still holds good, rinsed well in pure water, and stood up to drain, dried with cloth No. 1. After which apply the iodine pad, moist with iodide solution, composed of metallic iodine dissolved in a solution of iodide of potassium and water, but add no muriatic acid, as the slightest trace left will generate acid, and form an appreciably small quantity of chloride in the sensitizing bath, which often becomes a source of great annoyance, destroying the extreme sensitiveness of the bath, and causing minute holes in the collodion film. After having obtained a flat polish with the other cloths, pour on the collodion. Operators of standing differ on the best method of doing this, some pouring the collodion on from the right edge corner of the plate, others from the left, whilst others are of the notion that pouring on the centre, especially in large plates, gives a more equable coating, which ever way is best, the end in view obtained is all that need be cared for, viz.:—A flat even coated surface of collodion. After slightly setting, according to the nature of the material used, whether alcoholic or ethereal, place the plate on the dipper, to this all agree, although some discussion ensues as to the proper mode of placing the plate in the bath, some supposing that the plate, if longer than broad, should be immersed long ways; the why being answered, as the collodion is poured, so should the plate be inserted in the bath. Now, I think, theoretically and practically, this mode is incorrect, as by immersing the plate broadways, that is, when using a vertical bath, it has all the better chance of being covered with the nitrate solution, as it is the nature of ether and alcohol (being of less specific gravity than water) to rise to the top of the bath, thinning the solution, and giving an uneven coating of iodide of silver. But to those whose baths will not permit of their being inserted broadways, it may be observed, that, as generally in pouring on the collodion, one side of the film is a little thicker than the other, it will be best to insert the thinly-coated portion downwards, so that the upper portion being possessed of more iodide and consequently more absorbent of the silver, shall get but its due proportion. We are not of opinion of M. D. Van Monckhoven, in a recent paper translated into the *British Journal of Photography*, that after a little practice, the operator will be enabled to work in absolute darkness; although we believe in a very subdued yellow light being used in the sensitizing-room, and all care taken that no dust be raised during any of the operations therein; and whilst we insist on care and attention to every little point in the manipulation of the plates, we would not have you believe that "every operation in the collodion process should be performed as if you were working in the den of a sleeping tiger," as insisted on by the author of an article on photography in *Orr's Circle of the Sciences*. The time of immersing the plate in the bath is another question involving some controversy, the general method practised, and as given in photographic manuals, being till all the greasiness has disappeared. Now, Mr. Brown, in his paper on the Positive Process, touched on this head about two years ago, and showed that different results were obtainable by leaving the plate for a shorter or longer period in the bath; and not long ago Mr. Macnab adverted to the same subject with regard to negatives, and I think there is no doubt in the matter, as it is quite obvious that a collodion containing iodide alone will take less time to excite than a bromo-iodized plate, whilst either may

be influenced by a longer or shorter period in the bath. Then the point is to secure the plate at that moment when it is in the most sensitive condition, a matter requiring patient watchfulness in practice, but having obtained that important point with an unvarying temperature and light, negatives of nearly the same quality and density may be obtained for days together. Some assert that the plate should lie in the bath undisturbed for about one minute, then slightly moved about and again allowed to rest, till all the alcoholic streaks have disappeared. Now, I think and believe, if the plate could be kept moving in the solution all the time the sensitizing is going on, that a more equal surface would be the result, as it appears to me that when a plate is inserted in the bath the tendency of the alcohol and ether is to rise in streaks over the film, whereas, by moving it, say, with a circular motion, the evaporation is dispersed in the solution with less hurt to the plate. You will observe streaking more particularly as the bath weakens and becomes more saturated with alcohol and ether. Some use their baths in the old proportion of 30 grains to the ounce of water, without the addition of any iodide or bromide; others from 36 to 40 grains with such addition; but I must say I have seen as pretty negatives produced with a 30-grain bath as with either of the former; but the strong baths have this recommendation in their favour, they last longer. Some are of opinion that a neutral bath works best, with some collodions this cannot be doubted, but it has always a tendency to fog. Some prefer an alkaline bath, supposing that thereby they secure a film peculiarly sensitive to light; and, if we can place any faith in those instantaneous workers in the sun, and we have little reason to doubt them, it must be allowed they have all a leaning to the alkaline side of the question; but, for good, clean working, with an average exposure, that can be counted by oneself without annoying the subject, give me a slightly acid bath, as it has less tendency to fog than those previously mentioned. The time of exposure depends on the kind of negative required. I do not think that a large picture requires such a long exposure as a small one; but to get out detail and shadow, and to avoid those shocking contrasts of coal and chalk it is necessary to over-expose considerably; by doing so the high lights mellow into the secondary tints, whilst it imparts to the resulting picture soft lights in shadow. I think a slight over-exposure in the case of negatives for *cartes de visite* is a fault less heinous than under-exposure, or sometimes with a little management, in after intensifying, the "all overcrishness," so to speak, can be remedied.

Now there are a variety of developers, those principally in use are pyrogallic acid, gallic acid, and iron, into which the acetates and nitrates of other salts are introduced as accelerators or retarders. The gallic and pyrogallic acids, although yielding good negatives, being very slow of action, do not on this account receive the same favour in the eye of the professional photographer, as the plates manipulated with those acids require much longer exposure, and a greater amount of care and time in their development. The iron, being the most rapid developer, is the favourite, and the different formulæ for making up the various baths from this salt would occupy too much time in the rehearsal; suffice it to say, that the usual bath of protosulphate of iron solution, from twelve to fifteen grains to the ounce of water, with the usual amount of acetic acid and alcohol, is capable, when you have a good light, of producing negatives from the camera, without further intensifying. Now, the manner of pouring on the developer becomes a matter of argument also, some contending that it should be poured on as the collodion is poured; as the plate is immersed in the bath and lifted from the slide, I pour on the developer as I pour on the collodion, but not as the plate is inserted in the bath. In flowing the iron solution over the plate, it should be done as rapidly and evenly as possible, else streaks and stains will result; keep the solution moving on the plate, say, with a circular motion, till the detail is just out, and all the greasiness has disappeared; it should then be washed well under the water tap, care being taken that the strength of the water is not too great, as it is apt to exfoliate the film, which may yet be required to pass through an intensifying process, and as such, is likely to lift the collodion off the plate. The less the film is loosened, the better.

In the matter of fixing, there is also discussion involved, and the great question in this case is, which of the two substances, hyposulphite of soda, or cyanide of potassium, is the best and most expeditious agent in the removal of the unreduced iodide

of silver, the argument in favour of hypo being that it costs less, and is less deleterious to health; but I think (even admitting such to be correct) that cyanide is the best and cleanest fixer, clearing away all the organic matter that only serves to clog the pure image, allowing an intensifier to mingle at once with the metallic body, and clearing the blacks better than the hypo. From experience, I know that if you intensify after the plate has been fixed and dried, using iodine as a medium, you will find it much harder to get the pyrogallic solution to mingle with the silver, and further, after washing well (and it requires an immense washing to clear the film of the hypo), it is subject to crystallize under the varnish; and again, when your fingers are in the slightest way touched with hypo, dare you work near the silver bath, or touch prints on paper without leaving a trace of your whereabouts?

I look upon hypo-sulphite of soda as a very dangerous compound in the operating room. You can readily wash cyanide from your hands, as it has an affinity for moisture, but you will have some difficulty in removing the last trace of the hypo bath; more especially if any oxide stains are on your fingers. I am, therefore, of opinion, that friend Cyanide, though a dangerous fellow to drink, is the sharpest fixer, and those who would work expeditiously, for "time is money," should hold on by Cyanide.

If it were possible, always to develop the negative at once with iron, I think we would have the perfection of results, as those pictures which are done in the field, right from the camera, are indeed the most beautiful. In them "Ilka blade o' grass" has its *due* share of intensifying from the moment that the photographic sunbeam darts from its tender stem. I would avoid all after intensifiers, as they have a tendency to attack the finer gradations of shade, eating up those tiny tints which make the nature picture most valuable, intensifying those bolder lights that can resist their action, and, on the whole, swelling disproportionately the finer lines of the picture, I have no doubt but that yet we shall be enabled to do so, and then we shall bid farewell to those old intensifiers, to which we have been indebted in the past, and are still indebted, in a fix, to give our fair subjects the Ethiopian wash. The oldest intensifier with which I worked was the fumes of sulphur; then was introduced bi-chloride of mercury in conjunction with iodide of potassium, pyrogallic acid, gold, hydrosulphate of ammonia, ammonia. I show from the negative debris of the past specimens of the different intensifiers, but how simplified became the process of intensifying when it was made known that pyrogallic acid, with a slight proportion of silver solution, could still be precipitated in fine division, even after fixure. It gave photography on paper an impetus that no other intensifier had done previously, and until, as I said before, we can develop an image direct from the camera with iron, it must continue to hold supremacy over all other intensifiers with which we are yet acquainted. But even here we have a moot point for controversy amongst our ablest photographers; some contending that it is better to intensify the image before fixing, as if there is any detail not brought out by the iron, it is sure to come out with the pyrogallic acid, I have tried this method over and over again, and although occasionally successful, still I was never sure when I had arrived at the proper pitch of intensity, owing to the manipulation being done under cover of the yellow light, as the yellow film of iodide caused it to look denser than it really was, and often when the picture was fixed, it was only to find it coated with a precipitate of silver, either above or below the film; now it is a waste of time to intensify a picture that you do not know is worth intensifying or no, those are my objections to that mode, although I know many gentlemen who work it successfully. Others are of opinion that the pyrogallic solution should be added when the picture is just fixed; a very good mode; and I think, with all due deference to those who think otherwise, it is preferable to allowing the picture to dry before intensifying, because if the collodion shrinks in drying, as undoubtedly it does, it gives a sharpness to the detail, that can never be possessed by a picture that has been intensified after drying. Those who intensify their negatives after drying, are of opinion that they have a sharper or harder image to work upon; and there is no doubt they have, as the pictures have not been intensified previously; but when you coat a beautifully sharp piece of chased or carved work with paint, you take away materially from the sharpness thereof. It is covering the sword with scabbard; whereas if the pyro and silver had been added when the collodion and silver were in a porous condition, the effect of the intensifier

would be to surround the molecules of silver more completely, and fill up the interstices between them, thus binding the image more closely together, which, on drying, shrinks with the film, making a more compact picture. However, it has this drawback, if the collodion has any chance of being crapy it shows it more so than in the other case. In reference to drying pictures, I think it proper to observe that as the heat exercises a double effect on the negative at this stage it should be carefully dried; we know that the film shrinks with the drying heat as also that the glass expands. Now if the collodion be very contractile, the expansion of the glass acts as the great producer of what is called crapy negatives, for I have seen such crapiness displayed by collodions, in which I knew there was the purest material. But could we possibly reduce the image to the negative condition at once, I think the permanence of the negative would be enhanced, the beauty of detail in the softly and gradually blending lights and shadows would be more truthfully given than by our present intensifying processes, as, however small the distortion, it is still a distortion, for we clothe a beautiful subject in a drapery it was never intended to wear.

THEORY OF THE PHOTOGRAPHIC PROCESSES.

BY DR. D. VAN MONCKHOVEN.*

THE photographic processes may be divided into two distinct classes—first, the processes in which silver compounds are used; second, those in which silver compounds are not used. The first deserve principally our attention, because they are used almost exclusively, and because of the numerous investigations of which they have been the object.

1. *The Silver-Salt Processes.*—These can be divided into two categories. The first, including those in which the sensitive surface is exposed to the action of the light for a very short time, and the *latent* image is developed by gallic acid or any other reducing agent. The second, in which the sensitive surface is exposed to the light long enough to produce an intense blackening. In both cases the light acts in the ratio of its intensity, and produces *inverse* images, in which the light parts are reproduced in black, and *vice versa*; but, as in the first category of processes, the time of exposure to the light necessary to produce an image is *very short*, they are used directly in the camera, and in this way a *negative* is obtained. The processes of the second category, on the contrary, requiring a long exposure to light, the sensitive surface is placed in contact with a *negative*, through which the light reaches it, and forms a *positive* or image in which the whites correspond to the whites or lights of the object primitively reproduced. The processes in the two categories are thus very distinct in their uses. We will distinguish them in calling the former *negative processes* and the latter *positive processes*.

NEGATIVE PROCESSES, IN WHICH SILVER COMPOUNDS ARE USED.

Section 1.—Formation of the Image in the Camera.—Although most of the silver compounds blacken when exposed to the light, there are but few amongst them which yield an image by a short exposure, followed by the action of gallic acid or other developing agent. The compounds which possess this property in a remarkable degree are, in the order of their sensitiveness, the *iodide, bromide, and chloride of silver*.

The iodide of silver, being the most sensitive of the three, is used as the basis in the negative processes. It is produced by the action of the vapour of iodine on a surface of polished silver (*daguerriotype*), or by double decomposition in the texture of paper (*albotype*), of a layer of albumen (*albumen process*), of pyroxyline (*collodion process*), of gelatine, &c.

But here we meet with a question on which we have to insist. To form iodide of silver a soluble iodide is introduced in a porous surface, which is then immersed in a solution of nitrate of silver. Now it is possible that the substance which constitutes the porous surface has a chemical action on nitrate of silver, and then we have two silver compounds in contact, and even three, if we count the excess of nitrate of silver which remains on the surface. This is just the case in the albumen and gelatine processes, but not in the collodion process and in the process on unsized paper.

We also remark here a curious fact, and that is that the organic silver compounds in the albumen and gelatine processes are able to yield an image by a subsequent development, when no iodide of silver is present, provided a sufficiently long exposure to light be given. It is also remarked that in these

processes the addition of iodide of silver exercises but little effect, that the time of exposure is always very long, and that the image is visible before the development with gallic acid. The same thing takes place when the pyroxyline or the cellulose (paper) contains organic substances capable of combining with nitrate of silver, and this principally when the substances are albumen (Taupenôt's process) or gelatine (sized paper processes).

To examine how light acts in the negative processes, we will only consider perfectly pure iodide of silver (*daguerriotype*) or iodide of silver in presence of an excess of nitrate of silver (unsized paper)—(collodion).

Two theories are proposed to explain how iodide of silver, exposed during a very short time to light, possesses the property of condensing the vapours of mercury, or of attracting the particles of silver reduced by the action of gallic acid on the excess of nitrate of silver.

1. It is said to be a chemical action.
2. It is regarded as a physical action.

The first theory, which has been presented very clearly by M. Davanne, is almost exclusively adopted on the Continent. The second is due to Möser, and adopted by Mr. Hardwich and ourselves.

Let us analyse M. Davanne's theory. The principal arguments on which he finds it are the following:—

1. The salts of silver in general, the iodide of silver in particular, darkening by a sufficient exposure to light, should, by a very short exposure, darken also, but in an imperceptible way. However, the very small quantity of reduced silver acts as an attractive nucleus on the particles of silver set free by the gallic acid (and probably, also, in the opinion of this author, on the vapours of mercury).

2. If this theory be true, in certain processes in which the exposure is very long, the image will be visible. Experience proves that this happens in the albumen, gelatinized-paper, and waxed-paper processes.

3. Their principal argument consists in the celebrated experiment of Mr. Young, who had exposed an albumenized glass in the camera, and dissolved out the iodide of silver by hyposulphite of soda before developing, and had, notwithstanding that, obtained an image. Thus, says M. Davanne, the light has decomposed a small fraction of iodide of silver into iodine and silver; and the hyposulphite has not dissolved the silver, which, in the development, becomes then the attractive point for the particles of the same metal set free by gallic acid.

Let us examine the value of these three arguments.

1. A film of collodio-iodide of silver exposed to sunlight for $\frac{1}{100}$ th of a second, blackens under the influence of gallic acid, while it does not change visibly in five minutes' direct exposure (that is, if no bromide of silver or no other organic matter than the pyroxyline be present). Thus, let us repeat it, no appreciable change takes place in 32,400 times longer than the time necessary to produce an image by a developer, and notwithstanding that M. Davanne pretends that silver exists there, which is the cause of the subsequent reduction (*vide* our article in *The British Journal of Photography*, 1862, page 340.)

2. Yet in certain processes the image is visible before development. But let us well remark it here, it is precisely in these processes to which we have called attention; because, besides the iodide of silver, there also exists in the film an organic compound capable of combining with nitrate of silver. This is so true that a simple comparison will be sufficient to prove this fact beyond doubt. The collodion process is a hundred times more rapid than the albumen or waxed-paper process; and notwithstanding if an excited collodion plate and a waxed-paper (both with a base of iodide of silver) be exposed in the same camera, and for the same length of time, the collodion plate will show no image when the exposure has been long enough to show one on waxed-paper. But, as the reader will well understand, this image is not produced by the iodide of silver, but by the organic silver compound in the waxed-paper.

3. The third argument, the strongest one of the French theory, does not seem to us more convincing than the others.

In fact, how is it that the collodion plate, which is much more sensitive than an albumenized plate, does not give a trace of an image if fixed before developing, although it has been exposed in the camera for the same length of time?

This is very easy to explain. M. Davanne attributes the formation of the image in the experiment of Mr. Young to the decomposition of the iodide of silver. But that which proves it is not so, is, that an albumen plate without iodide of

* Read at a meeting of the London Photographic Society, Feb. 3, 1863.

silver gives a very vigorous image; and so it is in all photographic processes where an image is visible on removal from the camera.

Let us explain what takes place. In Mr. Young's experiment the film contains *iodide* and *albuminate of silver*. The first is not blackened by the light; the second, on the contrary, decomposes into a brown subsalt, which is soluble in nitric acid and caustic potash. The hyposulphite dissolves the iodide of silver, and leaves, not metallic silver, but blackened albuminate, which causes the development. We were the first to explain this phenomena in *The British Journal of Photography*, 1862, page 340.

According to us, then, no metallic silver is reduced by the action of light on iodide of silver, and no *chemical action* takes place, provided the iodide of silver be not mixed with an organic silver compound. If the least doubt remained in the mind in regard to the fallacy of M. Davanne's theory, the following facts would completely solve it:—

1. If light acts chemically on the iodide of silver in the collodion film, and metallic or suboxide of silver result, an application of diluted nitric acid must dissolve the silver or the suboxide. Now, a plate treated in this way, washed to take away the excess of nitric acid, and covered with a mixture of pyrogallic acid and nitrate of silver, yields an image which, although feeble, is still very visible.

2. Bromide darkens easily when exposed to light; and, notwithstanding that, it is less sensitive than iodide when a developer is used.

3. If the action of light on iodide of silver be a chemical one, it must be in proportion to its duration. Or, to state the matter in a more simple way, if in one second a vigorous image is formed, in two and three seconds it will be twice and three times as vigorous.

Now, in virtue of a singular property of the iodide of silver, it is not so. Light, to produce a maximum of effect, requires a certain time. If this time be overreached, the effect decreases and the image loses in intensity (Möser). This effect has been called *solarization*. This argument seems to us to be decisive.

Let us state here some curious facts discovered by Möser, and which we have had occasion to observe also.

A. A sheet of glass is exposed, behind a piece of paper in which some figure has been cut, to the light of the sun; the breath condensed on the glass will make the action visible.

B. A piece of silver plate gives the same result; but, if for the moisture of the breath we substitute the vapour of mercury, the image can be made visible by a much shorter exposure to light.

C. A copper medal, slightly warmed, is put on a polished plate of silver. The breath of the vapour of mercury will make the image visible, even if the experiment be made in the dark.

D. If the medal be left very long on the plate of silver, or even for a short time under certain circumstances which Möser has not been able to determine exactly (he only stated the fact), the image formed by the breath or mercury will be solarized, and can even be the reverse of the one of experiment C.

This fact presents a striking analogy with the action of light on iodide of silver—action which tends to reverse itself if the action be pushed sufficiently far, and which is indeed reversed if, while the image is being developed, the light be allowed to enter the dark closet.

We say, then, that *the action of light on iodide of silver is thus purely physical*;* and if in certain processes an image be produced by a chemical action, it is due not to the iodide of silver, but to an organic compound of silver.

But what is the nature of this physical action?

Dr. Hill Norris thinks electricity has something to do with it. M. Testelin, and, before him, M. Poey, think the molecules of iodide of silver have acquired electric polarity, and that, in consequence, the vapours of mercury and the silver become deposited on the affected molecules, in the same way that a light body is attracted by an electrized surface. But these hypotheses are, we think, mere assumption, and do not rest on a single precise experiment. Möser has been more explicit when he put forth the following principle, which was at least founded on neat and clear experiments—that when *one body*

* M. Beuvière remarked that if an iodized silver plate be, by means of a galvanic process, covered with copper, the copper will deposit on the parts affected by light.

has been touched by another one, vapours can make the point of contact visible.

It is supposed, according to this principle, that light can in a determined time give new physical properties to iodide of silver; but how can it be imagined that this time cannot be exceeded without the primitive action being destroyed? This negative action is, moreover, obtained long before the chemical action begins, at least we have no proof of its existence, when already the light has acted too long.

A fact which is not less singular is that certain reducing agents, although more energetic than pyrogallic acid and sulphate of iron, produce no image, although they set free the silver in the nitrate of this metal. Such are, for instance, hypophosphorous and phosphorous acids.

Let us say, then, without reserve, that we do not know the nature of the physical change which takes place by the action of light on iodide of silver. Möser's theory seems the most rational, but does not give a sufficiently exact explanation of the singular phenomena of *solarization* to be strictly true.

If, in the processes where pure iodide of silver is used, or iodide of silver mixed with nitrate of silver, the formation of the image must be attributed to a physical action, it is not so in the processes in which an organic silver compound is in contact with the iodide of silver; and in this case the chemical and physical actions take place together. What proves this, is that the organic silver compounds alone give images which are the more vigorous, as the action of the light has been pushed further, without offering the phenomenon of solarization—at least we have not been able to prove it.* The only silver compounds susceptible of giving images by a physical action are the *iodide, bromide, and chloride of silver*, and each possesses the property of solarization.

Section 2.—Development of the Latent Image.—The points where the sensitive substance has been acted upon by the light condense the vapours of mercury (daguerrotypé), or attract the particles of silver which have been reduced by the action of the developer on the excess of nitrate of silver which covers the film (wet processes).

In the first case, the image is formed by an amalgam of silver, the iodide of silver being subsequently dissolved by the hyposulphite of soda. In the second case, the image seems to be formed of metallic silver—at least, such is the opinion generally entertained. Recent experiments, however, have proved to us that it is not always so.

Images on albumen, gelatine, and waxed-paper, when treated with caustic potash, abandon an organic compound of silver, proves that their composition is complex. The images on collodion do not seem always formed of pure silver, either, as the following experiment seems to prove:—A collodionized and sensitized glass, after having been exposed to the light and developed with *pyrogallic acid*, is well washed, and then dipped in nitric acid. The image dissolves almost entirely; but it may happen that a weak, *scarcely* visible, image remains. This, I observed, is the case principally with old collodion, such as is proper for use in the dry process.

The acid being washed away, the image can even be developed a second time, and a new application of acid leaves always a secondary image.

The examination of the film proves thus:—

1. That the iodide of silver is not altered by the reducing agents.†
2. That the image is formed for the greatest part, if not entirely, of pure silver.
3. A fraction of the image is at times formed by an unknown substance.‡ The fixing agent then dissolving the iodide of silver, leaves in the film pure metallic silver, or silver almost pure, which, by rubbing, takes the metallic aspect.

* We have made numerous experiments on gelatinized, albumenized, and waxed paper, albumenized and gelatinized glass, and collodio-albumen. In all these processes, particularly those on albumen, the iodide of silver has appeared to us as being of no use; and it is sufficient, for instance, to albumenize a glass, and dip it in nitrate of silver, to obtain negatives in the ordinary way (vide Dr. Mouchhoven, the *British Journal of Photography*, for 1862, p. 349).

† Some authors affirm the contrary, and pretend that a film of pure iodide of silver can be developed with pyrogallic acid without the addition of nitrate of silver. The experiments of M. Barreswil and Davanne, Hardwich and ourselves, prove the contrary.

‡ What is this substance? It is soluble in hyposulphite of soda and cyanide of potassium. When dissolved by the latter the image can again be developed weakly. The silver, deposited by a mixture of pyrogallic acid and nitrate of silver, is entirely soluble in nitric acid, thus it does not come from the reducing agent. Moreover, the same thing takes place with sulphate of iron.

PRIZES AT THE PHOTOGRAPHIC EXHIBITION.

ADJUDICATORS' REPORT.

As to four of the medals, we have had no hesitation in fixing upon the names of those best entitled to the honour of the award.

To begin with the Amateurs' Medal. There is a beautiful picture exhibited by the Earl of Caithness; but it is simply a translation, though very faithful and artistic, of an accidental effect of nature. Greater merit is, we think, shown in the series of studies from nature exhibited by Lady Hawarden.

2. In the class of elaborate figure compositions, we can see nothing that can be placed on a level with Robinson's "Bringing Home the May."

3. As for reproductions, Thurston Thompson is *facile princeps* in this Exhibition.

4. Of instantaneous views, the series exhibited by Col. S. Wortley stand alone in their excellence.

So far it has been easy for us to assign the places of honour. In landscape subjects we had much more difficulty, and have not without much hesitation made up our minds as to the rightful claimant of the medal. Messrs. Bedford, Annan, Mudd, Vernon Heath, Dixon Piper, and White have each exhibited pictures of the greatest beauty. If the medal were to be the reward of the best *single* production, we might have found the duty of deciding even more difficult than it is. The medal, however, is to be given as the reward of the greatest general excellence. We find instances in the works of each of the gentlemen already named, either of happy choice of subject, or of skill in the composition of their picture, or of due attention to contrast of light and shade, and to gradation of distance and atmospheric perspective; but we think that we see in Mr. Bedford's works the most complete union of all the qualities which must be united in a good photographic picture.

Taking the same principle of general excellence as our guide in examining the merit of the portraits in the Exhibition, we consider that M. Claudet is entitled to the first place; but we must add that, in delicacy of treatment, nothing can be finer than Mr. Williams's vignette portraits.

The carte de visite portraits of M. Joubert are unsurpassed, we think, by any of that class of pictures. We were also much pleased with the portrait of Thomas Carlisle, by Jeffrey, and with one of the large portraits exhibited by Mr. Voigtlander.

R. FENTON.
J. DURHAM.

REMEDY FOR CRACKED VARNISH.

BY H. R. NICHOLS.

MANY of your correspondents ask for a method to restore negatives that have become useless by the cracking of the varnish. Having frequently repaired negatives which have suffered that misfortune, I will briefly state the way I manage it; but must state at the same time that a little practice and a little caution is necessary to ensure success.

The apparatus I use is constructed in the following manner:—Procure a tin dish about an inch larger each way than the negative and about two inches deep, with a piece of tin, the size of the plate, or of the largest size of plate used, raised about a quarter of an inch from the bottom; next a rim of wood on the outside to be laid on the top edge, so that a plate of glass, when laid on, fits comparatively air-tight.

Now for manipulating. First, to know the solvent for the cracked varnish proceed thus:—Touch the varnish with alcohol on the end of a glass rod, the plate being slightly warmed at some unimportant part of the negative. If it dissolves, alcohol is the solvent; if not, benzole is probably the solvent of the gum in the varnish. That having been ascertained, we now proceed. Place the injured negative on the raised part of the dish; pour into the lower portion a little

alcohol or benzole, whichever be the solvent, taking care that none of the spirit comes in contact with the varnish surface. Put the glass cover on, and heat the dish by any convenient method—I use a hot tile. The vapour of the spirit will cause the varnish to swell; the cracked portions will unite, at which period remove the glass top, let it cool gradually, and finally varnish again.

2, St. Jude Street.

THE APPLICATION OF PHOTOGRAPHY TO THE MAGIC LANTERN EDUCATIONALLY CONSIDERED.

BY SAMUEL HIGHLEY, F.G.S., &c.*

The bag of oxygen, when wanted, is placed between a pair of pressure boards; half-hundred weights are placed on the upper edge of the boards, and the gas is expelled at any desired amount of pressure.

As the pressure boards, as ordinarily constructed, are of inconvenient size, I have adopted a suggestion of Mr. Madden, the engraver, a gentleman very conversant with philosophical instruments, and make them to fold up, so as to make packages of a more convenient form, the parts, when opened for use, being kept firm by clamps and swivel bars. The arrangement adopted will be readily understood by aid of Figs. 5 and 6.

Fig. 5.

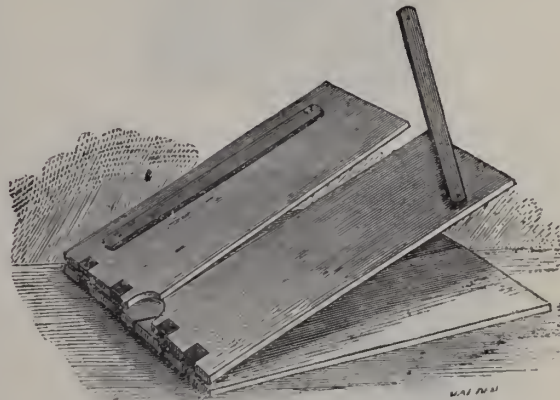

PRESSURE BOARDS OPEN FOR USE.

Fig. 6.



THE SAME FOLDED FOR TRAVELLING.

If both gases are to be used under pressure, the connecting tubes of their respective bags are connected with the pipes of an oxy-hydrogen jet (Fig. 7), whence they are conveyed to a mixing chamber, from which the combined gases are projected upon a lime ball placed at about one-eighth of an inch from the nozzle of the jet. The lime-ball is fixed upon a pin that is turned from time to time; or, if the mixed gases are to be used under greater pressure, the lime-ball is kept in constant rotation by means of clock-work, to prevent holes being burnt in the lime, and the light being thus thrown out of focus of the lenses, or the light being diminished in intensity through the distance between the jet and lime cylinder being increased beyond the proper point. The proper proportion of the oxygen to the hydrogen is regulated by stopcocks till the best effect is produced. If a picture only 10 feet in diameter is to be produced, a very simple arrangement may be employed, a fine jet of oxygen is forced from a bag

* Continued from p. 69.

under moderate pressure through a flame of house gas burning at the end of a brass pipe connected with a flexible tube to the

Fig. 7.

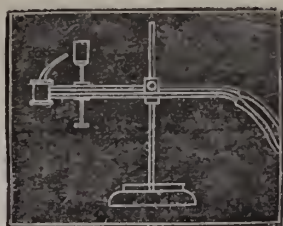

burner of a lamp or other gas supply, Fig. 8, the mixed gases being projected on a lime cylinder, as in the previous arrangement, the incandescent limo being the real source of light.

Fig. 8.

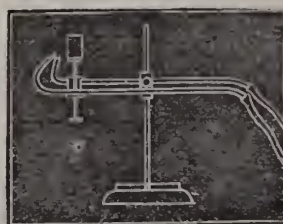

When, however, house gas is not attainable, and the trouble of making pure hydrogen is an objection, a very good light may be obtained by forcing a fine jet of oxygen through a spirit flame on to a limo cylinder, by the arrangement shown in Fig. 9.

Fig. 9.

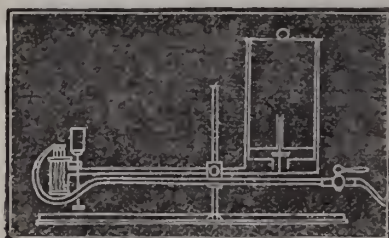

It should be stated that an argand oil lamp, even if the brilliancy of the light is increased by adding camphor to the oil, is not suitable for photographic views.

If the limo cylinders are to be subjected to a lengthened exposure, under great pressure, they must be made from the best and hardest lime; if under moderate pressure, soft limes may be employed with advantage. Mr. Fryer, of Manchester, has proposed the employment of cylinders, made of two parts of calcined magnesia to one part of sulphate of limo mixed with water, cast in a mould, and then baked, which he states, after careful photometric comparison, gives a light, as compared with ordinary limes, as 54 to 28; as far as I have tried this form of cylinder, I cannot confirm this statement, but much may depend upon the details of preparation.

(To be continued.)

Correspondence.

THE FRENCH PHOTOGRAPHIC EXHIBITION.

SIR,—I notice in last week's NEWS a statement from your foreign correspondent relating to the Photographic Society of Paris, in which, amongst other things, it is announced that an exhibition of photographs will be held there on the

1st of May next. English artists are reminded of this; and some flattering remarks are added with regard to their photographs. Having myself sent several landscape photographs to the last exhibition held by the Paris Society, I feel, with the foregoing announcement before me, that I may be doing some service if I relate what has occurred to me in connection with that exhibition. Let me, however, say that I do this with reluctance, and that I greatly regret the necessity of making this public statement. It will, though, be seen that I have given those who should have furnished the explanation required more than reasonable opportunity for doing so.

The photographs I sent to the Paris Exhibition in 1861 were in six frames, arranged as my exhibition pictures usually are, some containing four subjects, others two. They were forwarded by myself, packed in a case, carriage paid, duly arrived in Paris, were hung, and I possess a catalogue of the Exhibition in which they are mentioned.

As the time approached when, according to the original announcement, the Exhibition should have been closed, I received a letter informing me that it had been determined to keep the Exhibition open for an extended period, at the end of which period, if I desired it, my contributions should be at once returned to me; or, if I did not object to it, they should be retained by the Society until the time came for sending to London the Paris contributions to the International Exhibition, and they should come with them.

I replied by sending the address of my own agent in Paris, and requested that, at the close of the Exhibition, my pictures should be packed up and sent to him. Some time then elapsed, and not hearing anything of them, I wrote to the Secretary of the Society, but had no reply, and I made other applications by letter, but without any result.

Being in Paris at the commencement of this year I determined, if possible, to obtain an explanation of this matter; and having had the good fortune to make the acquaintance of Mr. Ernest Lacan, I asked that gentleman to go with me to the Secretary of the Society.

Perhaps I should mention here that just before going to Paris I heard that Mr. H. P. Robinson had had similar experiences with regard to his contributions to the Paris Exhibition; his case, however, being a stronger one than mine, inasmuch as, beyond the pictures sent for exhibition, he sent a large number of duplicates for sale. But, to continue:—On the 8th ulto., with Mr. Lacan, I called upon the Secretary at the rooms of the Society, who, while admitting that my pictures were received, stated that he was then quite unable to give any explanation as to what had become of them. Mr. H. P. Robinson's contributions he knew nothing about, and stated that he did not even know him as an exhibitor! He would, however, make every possible inquiry, and we were to call the next day. This we did, but nothing had been found out; it was promised me that the inquiry should be continued, and that I should be written to.

Now, sir, I submit that from the 9th of January to the 5th of February is reasonable time for inquiry, but as yet I have had no letter; and, though I can now hardly expect that even this public statement will bring me the information I have hitherto failed to get, it may be useful to those who intend to send pictures to the forthcoming exhibition. I do assure you that I regret that this has happened; had I been treated with even the most ordinary consideration I should have been happy to have continued an exhibitor at Paris.

VERNON HEATH.

43, Piccadilly, February 5th, 1863.

[We regret exceedingly the necessity for publishing the statements above made, or in any way damping the ardour of intending contributors to the French Exhibition; but such circumstances call for explanation or remedy. In Mr. Robinson's case, we believe that not less than ten copies of "Fading Away" were sent and never accounted for. The fact that the prints are now scarce and very valuable renders their loss the more annoying.—Ed.]

Photographic Notes and Queries.

PRIVATE PHOTOGRAPHIC EXHIBITION.

SIR,—I was surprised on reading your article of Friday last, not having met with the disapprobation of other photographic journals or of the local press. Your criticisms in no way daunt me, already nearly all the space is engaged by some of the best artists and well-known publishers; a sufficient proof of the confidence reposed in the projector of the scheme.

By the condition of six postage stamps, the Contributors' Guide is likely to be desired only by those wishing to forward specimens.

The guinea intended to be used for purchasing prizes and procuring judges does not refer to *all* exhibitors, but to those only who, after fifteen clear days' inspection of the works of other competitors, may deem it expedient to invest their money. Of the gentlemen kind enough to act as umpires, some may not be able to do so without considerable loss of time, not to speak of travelling expenses; it is therefore but natural that those to whom the advantages accrue should provide for such contingencies.

Should the above plan fail in making the exhibition defray its own expenses, four gentlemen of property and respectability, who take an interest in the undertaking, are pledged to me as manager to bear an equal share of the liabilities. These gentlemen's names I am not at liberty to set forth except when their financial connection with the exhibition may render it necessary. One important item you have not laid before your readers, many of whom may not have had an opportunity of seeing my circular, viz., the packing, arrangement and repacking of all goods sent. This, together with catalogues and other incidental expenses, will be no slight matter, considering that I run the risk of that failure you have so kindly prognosticated.

Supposing the whole proceeding to be a "blunder," on whom will the responsibility devolve? Not on the exhibitors, they are merely invited to accept an opportunity of displaying their productions, but on the daring individual, the originator of an enterprise, who, though "a private unknown individual," will be able to carry out the entire project to the very letter.

The insertion of this in your next number will greatly oblige, sir, your obedient servants,

A. G. GRANT, *Manager*.
G. LASSALL, *Secretary*.

TO PREVENT THE SILVER BATH BECOMING DISCOLOURED.

SIR,—I have much pleasure in being able to give a method for preventing the silver bath turning colour after using albumenized paper.

Instead of dissolving the silver in distilled water, use common hard water that has been *boiled* in an ordinary kettle, and then let it get quite cold before dissolving the silver.

I tried the plan of using common water before boiling, but I found such an objectionable deposit in the bath, so gave it up.

There is a slight deposit by using my method, which is scarcely worth mentioning, and which had better remain in the bottle.

I have had this plan in use for the last two months, and my bath now is as white and clear as when first made.—I am, sir, yours, &c.

Bristol, Feb. 6, 1863.

WM. CLARK.

HOW TO KEEP GUN COTTON.

DEAR SIR,—The following incident, which occurred to me the other day, may, perhaps, be interesting to some of your readers, as showing the danger of keeping pyroxyline closely stoppered. I have had some pyroxyline by me for about a year, made from paper; it has been in a stoppered bottle, cemented, and capped with bladder and leather. I happened to take it from the cupboard in which it has been kept, and observed the pyroxyline, in the upper part of the bottle, to be slightly tinged with yellow, so thought it advisable to open it, knowing that pyroxyline keeps much better when exposed to the air. I took off the leather and bladder caps, and removed the cement, when the stopper flew out with a loud report, large quantities of nitrous fumes were emitted, the bottle was cracked, and quite hot at the upper part. I have always made my own pyroxyline in India, and have found it keep perfectly well, simply wrapped in paper, and placed in a cupboard, or on

a shelf. I have pyroxyline, which was made three years ago, and has been kept in this way; it is in the same condition as when it was made. I have received samples of pyroxyline in India, which were sent out to me by different firms in England, and there were always nitrous fumes in the bottle—sometimes plentiful, sometimes in small quantity. I have kept the same pyroxyline for a considerable time afterwards, wrapped in paper, and it has not suffered any further decomposition. I feel sure that pyroxyline may be kept for any time if exposed to the air. I have kept it myself for three years in this way; if it is hermetically sealed, it will begin to decompose in less than six months; much, doubtless, depends on the thorough washing of the pyroxyline. The samples I have alluded to I believe to have been perfectly washed; but I am confident that the above remarks will apply to any cotton, however well washed.—I remain, yours faithfully,

N. L. NOVERRE.

25, South Street, Park Lane, Feb. 8, 1863.

[Under some circumstances pyroxyline will undergo change with keeping, however stored; but it should never be kept airtight. We always keep it in paper parcels, or in a wide jar with loose paper cover, and have kept it for months and years without injury.—Ed.]

SUBSTITUTES FOR PRINTING FRAMES.

DEAR SIR,—Having some time since invented substitutes for printing-frames, which I find to answer perfectly, and at the same time do away with the slightest risk of breaking a negative, whilst the cost of them is trifling. I send you a description of them for the benefit of your readers. The principle in all sizes is the same, but I will describe the frame for a $\frac{1}{4}$ -plate negative. I first get a 5×4 plate, and having measured the right length across it, when at full tension, of a very wide piece of elastic; cut it off, and sew two hooks to each end of it. I do the same with two other pieces. I then take a $\frac{1}{4}$ -plate and cut it in two with a diamond. The frame is now complete, and is thus made use of;—The $\frac{1}{4}$ -plate negative is placed on the 5×4 plate, then the sensitive paper, and pads of soft paper, &c., cut exactly $3\frac{1}{4} \times 4\frac{1}{4}$ then the half pieces of quarter plate, and then the elastics hooked over all onto the 5×4 one, over each half, and one over the joining (but this is not essential). If properly made there is abundance of pressure, no risk of breakage, and they are easier to open for inspection than the ordinary frames.—Yours most respectfully,

D. WARD.

Manchester, Feb. 3, 1863.

GUTTA-PERCHA PAPER.

DEAR SIR,—It seems that there is nothing new in the world. Scarcely is an improvement suggested, or something new introduced when a somebody appears revealing that it has been done in such and such places, and even in our neighbourhood. Now there is only one question that arises from such assertions: if paper has been prepared by Mr. So-and-so, &c., and it proves valuable, why was it not made public? What is the use speaking now about filthy lucre, sordid gain? For my part I must confess I never heard of any other paper but albumenized and plain, and lastly of Mr. Cooper's, to whom photographers owe many thanks. Mr. Sutton's paper will prove a great boon when he has overcome all difficulties. The preparation of the waterproof solution is even not very easy; it may do for waterproofing shoes but not paper; but even when it has been done properly, there are other things which most leak out in order to obtain a fit paper for photography. I take the liberty of enclosing two *cartes de visite* printed on my gutta-percha paper; they were done by Mr. Hogg, of Kendal, and you will see his remarks. The paper sent to him was Causton's, which I had in possession for the last seven years. He speaks of the slow printing, which I account for the not having known the strength of his bath. I will feel obliged if you point out the defects, and it will guide me how to improve. I must not omit to state that I have prints which were only washed for five minutes, and are now for four weeks exposed to light, and I do not perceive any change. I expect some paper from London, and by your permission I will send you some prepared paper; and if you should find it good, I shall feel glad that my experiments have not been in vain. As customary, begging you to pardon my bad English, I remain yours respectfully,

ALEX. ARNSTEIN.

Ambleside, January 27, 1863.

[The prints received are a trifle flat and inky in tone; but that would doubtless be overcome by practice.—Ed.]

Talk in the Studio.

SOIREE OF THE PHOTOGRAPHIC SOCIETY.—The soiree of the London Photographic Society will be held on the evening of Friday the 20th. inst., in the Suffolk Street Gallery, where the exhibition is now held.

NEW EXHIBITION.—We understand that in consequence of the flattering manner in which Mr. Highley's paper on "The Application of Photography to the Magic Lantern" was received by the members of the Society of Arts, he proposes opening a public evening exhibition of his science and art photographs, at the Burlington Gallery, 191, Piccadilly, on Wednesday next.

"COAGULATING" THE SURFACE OF ALBUMENIZED PAPER.—Mr. A. Wood, of Brunswick Street, Edinburgh, informs us that he has found an easy and efficient method of rendering insoluble, or "coagulating," as it is improperly termed, the dried albumen on albumenized paper. He says:—"The means I employ is a pipe leading from a steam boiler into a receiver—the steam is admitted or shut off by a cock at the receiver. I enclose the paper in a box having holes in the sides, and covered with blotting paper and allow it to remain five or six minutes. When taken out it is only slightly damp, and completely changed in appearance, the surface being much more brilliant and beautiful." Mr. Wood has sent us some samples in which the surface is rendered quite insoluble. He states that with a 40-grain bath very brilliant results are obtained. We consider the subject very important, and shall take an early opportunity of giving it more attention.

To Correspondents.

COLOURED GLASS.—EXCELSIOR forwards a specimen of yellow glass for examination. It is coloured throughout, and is of rather a light colour.

In the spectroscopic it is seen to be tolerably opaque to the chemical rays, but a few of the blue struggle through, which would render it unsafe in bright light. To Excelsior's further questions we may state that common water may be used for making an iron developer, but if it contain any large proportion of chlorides, carbonates, &c., it may cause some trouble by throwing down the free nitrate on the plate as a chloride or carbonate, instead of allowing it to give density to the negative. The chloride of gold to which you refer will doubtless answer for a toning solution after the Abbé La Borde's formula.

G. F. S. forwards some flashed orange glass. It is of the best quality, and perfectly trustworthy as a medium for glazing the dark room.

BRADFORD.—Dr. Hill Norris's plates will keep after a packet has been opened, but not so well as before. It is important to keep dry plates air-tight as well as protected from light. Moisture and vapours present in the atmosphere are often injurious to dry plates.

R. W.—The No. 1 Triple is not intended for, nor well suited for card portraiture; nor is it suitable for stereoscopic work. It is of a focus too long for such work. If you require a lens for both these purposes, a quarter-plate or No. 1 B of the maker you name will meet your wants.

A.—Two grains of iodide of potassium are sufficient for a pint of nitrate bath. You have added too much, and probably, from the sandiness you describe, supersaturated your bath. The two grains in the formula to which you refer doubtless are meant for the whole bath, not for each ounce of solution. Dilute your bath with an equal bulk of distilled water; let it stand all night, then filter, and add sufficient nitrate of silver to make it the proper strength. 2. The path of insensitiveness to which you refer may arise from the film having got dry at that end before immersion, or from a variety of causes which we cannot with certainty specify without seeing a plate.

INQUIRE.—We do not know of any plan of drying prints except hanging them up or spreading them out. If they are blotted off with clean blotting paper, to remove the surface moisture, they soon dry, however arranged.

ANXIOUS.—If, when using pure albumen, it sink into the paper, drying dull and irregularly, the fault is in the paper, which is too absorbent, and probably new. Untilage has thoroughly hardened the surface of paper, the size is very apt to become partially dissolved; this will cause the albumen to sink partially in and dry with a dull, irregular surface, disfigured with curtains. The only way to meet this difficulty when the tendency exists, is to float the paper for a very short time, not more than a few seconds, or indeed not more than on and off the albumen, taking care to add no ammonia to the latter as sometimes recommended, and to have the room at a sufficiently high temperature, not lower than 70° Fah. There is no "secret dodge" in successful albumenizing, except the knowledge of conditions arising from experience, and good manipulation. We do not know of any book which gives any special details of this subject.

AN ANATEUR.—Mr. Sutton's patent is for a method of preparing paper with india-rubber previous to albumenizing. The paper is to be had of Messrs. Ordish and Lampray, Paternoster Row. The resinized paper process is due to Mr. Cooper; paper by his formula is prepared by Messrs. Francis and Co., Islington. We have not tried the rose-tinted paper.

H. S.—It somewhat depends upon the quality and form of your quarter-plate lens, as to whether it is well suited for enlarging at all; but there is no especial limit to the extent of enlarging to which it may be put. A triple lens is the most suitable for enlarging. 2. Considerable difference of opinion prevails amongst authorities as to whether the presence of some free nitrate increases the sensitiveness of a dry plate. The general opinion is that it does; but Dr. Hill Norris, one of the best authorities on the subject, says it does not, and that his instantaneous dry plates have no free nitrate present.

P. SKEOLAN.—A form provided at the Register's Office at Stationer's Hall must be filled up with the necessary particulars and left at Stationer's Hall, together with one shilling for each photograph to be registered. You will find full particulars in the number for December 26th last, and some preceding numbers there referred to. Also in our ALMANAC.

LENOIR.—The tone and general character of the print are good. The dark patches doubtless arise from the varnishing. We have noticed sometimes that negatives intensified with bichloride of mercury when varnished with a rather thin varnish, especially if the plate be made a little too hot, are spoiled by the varnish passing through the film made porous with the mercury, and settling in small patches between the film and the glass. In all these patches the negatives become more transparent, and the patches print blacker, as in your case.

M. D.—Mr. Osborne has not published any specific work on photolithography. He delivered a lecture on the subject in Melbourne, which was published in the English photographic journals, and also in a small, separate pamphlet. In this lecture, contained a sketch of various photolithographic processes, which you will find on pp. 374 and 388 of our fourth volume. Various articles on the subject, historical and practical, have recently appeared in our pages. A work recently issued by M. Poitevin, entitled "A History of Printing without Salts of Silver," also contains much information on the subject.

S. R.—Your figures are lighted with too much diffused and too little direct light; and you have decidedly too much front light. There is no appearance in your prints of want of bromide. 2. Of the two makers of lenses you name, the latter is the best.

ENIGMA.—Dallmeyer's new stereo lens is not intended for card portraiture, and with full aperture it will not be likely to answer the purpose satisfactorily. To obtain good definition with it over the whole of a standing figure a small stop will be required. For rapid work in card portraiture you must procure a lens especially constructed for the purpose. 2. A solution of iodine is sometimes used in intensifying before fixing, prior to the application pyro and silver. We will make use of your other communication, for which accept our thanks.

X. Y. Z.—We do not know anything of the qualities of the first lens regarding which you inquire; but have seen excellent work with that of the second maker. 2. A great many qualities go to constitute rapidity and excellence in a lens. The conditions you name, large diameter, short focus, and pure colourless glass, are important in securing rapidity, but there are others not less important, which the skilled optician must consider. Every varying density in the glass, for instance, will require some modification in the figure of the lenses to meet the case. There are many such points, which are the business of the optician, and he who best understands his business produces the best instruments.

J. W. S.—Our pages have almost teemed with recipes for toning baths during the last few years. That with the acetate of soda is as simple as any. Here it is again: chloride of gold, 1 grain; acetate of soda, 30 grains; distilled water, 6 ounces; mix 24 hours before use. With skilful manipulation, 1 grain of gold will tone from 1 to 2 sheets of paper. A deep tone depends on a good negative, strong nitrate bath, good paper, deep printing, and sufficient toning.

A. B. D.—If you send us a specimen of the defect we shall be able to form a better opinion of the cause.

JOSEPH FORD.—We will take an early opportunity of noticing your slides. 2. You may copy engravings in which no copyright exists, but you may not photograph copyright engravings.

G. STANHAM.—Some samples of chloride of gold are adulterated, but as a general principle, the adulteration is not of an injurious kind beyond robbing the purchaser of a portion of the gold he pays for. A common adulteration is chloride of sodium. Any solution made with such gold will be weaker than intended in proportion to the amount of adulteration present. We have no means of saying that the samples sold by any manufacturer are better or worse than others. 2. If you make an ammonio-nitrate bath, make it according to the formula we have given several times; but if you are uncertain of your manipulation make a plain 70-grain bath and use it as nearly neutral as possible, or very faintly acid with nitric acid.

J. M. LEAHY.—In the case referred to, Mr. Barrett used the Stanhope lens almost in contact with the portrait lens, and your conjecture that the latter in such played an unimportant part in the matter is correct. The greater power of the former would almost ignore the action of the portrait lens. The most satisfactory lens for the purpose is a microscopic object glass of about 13 inch power. You might use one of the lenses you name as a condenser. Your letter, unfortunately, got mislaid, or it would have had attention sooner.

WILLIAM COCK, Rio de Janeiro.—This gentleman is requested to send his address to Mr. Wall, who, having mislaid his first letter, was unable to send the desired information. A second note received since did not give the address.

Several correspondents in our next.

Photographs Registered during the Past Week.

- MR. H. J. WHITLOCK, Birmingham,
Portrait of Prince Louis of Hesse.
- MR. THOMAS WARREN, Newcastle-on-Tyne,
Photograph of "Old Nag's Head," and other buildings.
- MR. C. M. DRAYSON, 13, St. George's Street, Canterbury,
Two Portraits of Henry Alfred, D.D., Dean of Canterbury.
- MR. A. S. WATSON, of Great Yarmouth,
Portrait of the Prince of Wales.
- MESSRS. PETSCHLER AND CO., Manchester,
Portrait of Professor Bunsen,
Portrait of Professor Kirchhoff,
A Group, Bunsen and Kirchhoff,
Portrait of Rev. Dr. Beard,
Portrait of Rev. Dr. Parker.
- MR. JOHN STUART, Glasgow,
Two Portraits of Rev. H. M. Williamson,
Two Portraits of Rev. George Phillip,
Portrait of Rev. Ivie Maclellan.
- MESSRS. SCHNADHORST AND HEILBRONN, 433, West Strand, London,
Portrait of Augustus Troumouger, Esq.

THE PHOTOGRAPHIC NEWS.

Vol. VII. No. 233.—February 20, 1863.

CONTENTS.

	PAGE		PAGE
Fuming Albumenized Paper with Ammonia	85	The Application of Photography to the Magic Lantern Educa-	
The Photographic Exhibition.—Fourth Notice	86	tionally Considered. By Samuel Hihley, F.G.S., F.C.S. ...	92
Printing Difficulties. By a Photographer's Assistant	87	Proceedings of Societies	93
On Iron Developing Solutions. By M. Me. A. Gaudin	87	Correspondence.—Foreign Science, &c.	94
An Apology for Art-Photography. By O. G. Rejlander	88	Talk in the Studio	96
Thomas Sutton, B.A., on Art-Photography. By Alfred H.		To Correspondents	96
Wall	90	Photographs Registered during the Week	96

FUMING ALBUMENIZED PAPER WITH AMMONIA.

Palmar qui meruit ferat, is a good motto at all times, and is frequently of especial application in an art-science like photography, which owes its rapid progress and present proud position to the ability and ungrudging liberality with which so many of its votaries have given their discoveries, small and great, to the general stock. It is not unfrequently a matter of some difficulty to trace the exact origin of many new ideas or improvements, as they often appear to spring up simultaneously in different quarters. Here is one of those cases in which a misunderstanding has arisen regarding a process, of which we scarcely know yet whether it is to become important and popular, or to drop into "the limbo of vanities" and be forgotten. The worthy Editor of the *American Journal of Photography* has received some unintentional injustice at our hands, in not receiving the amount of credit due in connection with the process of forming ammoniac-nitrate of silver on albumenized paper by fuming. The case stands thus:—

Some time last Autumn, Professor Emerson communicated to us in confidence the process in question, for our own use, and not for publication, as the originator, Mr. H. T. Anthony of New York, did not wish it published then. We had a dim impression at the time that we had met with the idea before, but could not quite recall it. We had respect to the confidence reposed in us, and did not publish any allusion to the matter. A few weeks afterwards, Mr. Penny, of Cheltenham, wrote to us a letter for publication, stating that such an idea had occurred to him, and that he had tried it with success. We could not of course, in fairness to our American friends, publish this letter without alluding to the fact, that the process was used by some gentlemen in America, whilst Mr. Penny's letter announcing his independent discovery, absolved us from secrecy. We therefore frankly stated the circumstances, endeavouring to do justice to Mr. Penny, to our readers, and to Professor Emerson. A few weeks afterwards we received from that gentleman a letter, in which, amongst other things, he asked, as Mr. Anthony's secret discovery had got into print, would we give him due credit. It was really Mr. Penny's discovery which had got into print, with a courteous allusion to the prior use of the process in America; but in deference to a gentleman who possessed our esteem, we made the desired announcement. In reference to this, a recent *American Journal* contains the following remarks:—

— *What does it mean?* The editor of the *News* (December 12), announcing the receipt of a letter from Professor E. Emerson, concerning matters photographic in America, says, "In the first place we are desired to place on record that it is to Mr. Henry T. Anthony, of the well-known firm of E. and H. T. Anthony, photographers are indebted for the discovery of the value of ammonia fumes in printing on albumenized paper. . . . Professor Emerson communicated to us the process in confidence."

Some further remarks follow in reference to Mr. Sellers,

who, having seen the announcement first referred to in our pages, wrote to a contemporary promising particulars, and adding that without doubt the discovery was due to Mr. Anthony. The Editor then further remarks:—

How strangely sound the expressions we have underscored! The fuming process was published in this journal, for plain paper, by Mr. Campbell, of Jersey City, vol. i. p. 57, and for albumenized paper by the editor, vol. iv. p. 500. Mr. H. T. Anthony is not a subscriber to this journal, and therefore may be excused by some for being far behind the times. Mr. Sellers without doubt has overlooked the articles in this journal, and will make the proper explanations. Professor Emerson has informed us that he was not aware of the publication of the process in this journal, not having been at the time a subscriber, and that his information came only from Mr. Anthony. On the supposition that the claim of Mr. Anthony is just, what a funny thing it is that we must get the news not direct, but by way of Philadelphia and England! From 501 Broadway to Canal Street is only a good stone's throw; but by the other route it is 6,000 miles! We have more to say on this subject. We only add now that we never heard the name of Mr. Anthony connected with the fuming process till the receipt of the English journals above quoted from.

To whom the discovery was really due we cannot state. Mr. Anthony, it is quite possible, may have discovered it and used it years ago. But to the *American Journal* is unquestionably due the merit of first publication. We stated that when Professor Emerson first mentioned the matter we had a dim conviction that we had heard the suggestion before. If our readers will turn to p. 213 of our last volume, May 2nd, 1862, they will find an article from the *American Journal* in which the suggestion is made. The precise fact had escaped our memory, an uncertain impression only remaining when the matter was again brought under our attention. It is only just now to recall the fact.

About the exact value of this process we are less certain; and at present wait for evidence. It stands on our notebook, amongst many more processes, to be tested and verified when time and circumstances permit. Mr. Penny, of Cheltenham,* exhibits, in the present exhibition, some illustrations, from which it appears that a 40-grain silver bath with the fuming gives equally good results as a 60-grain bath without it. On the other hand, we have had some communications from an able photographer, from whom we learn that in his hands the fuming was a failure. No accession of sensitiveness was gained, and the prints were flat, poor, and grey, much inferior in brilliancy to prints from the same paper, silver bath, and negative, without the use of ammonia.

Whilst referring to the above subject, we may take occasion to correct another misapprehension in the mind of our American contemporary. In another article he complains a little of the "harsh criticism" on American inventions of English photographic journals; and states that perhaps

* A contemporary, by the way, has overlooked the fact that the use of ammonia fumes in printing is an independent discovery by Mr. Penny, and refers to his specimens as the result of Mr. Anthony's suggestion.—Ed. P. N.

they receive "some tinge of the present prevailing prejudice against almost everything American." We feel concerned to disabuse our American friends from any such notion. We are profoundly thankful that the charge of a scientific journal absolves us from the duty of dealing in any way with the complicated difficulties which now harass the great American nation, and from which we wish them a speedy and satisfactory deliverance. But, as regards American photography and photographers, we can assure all concerned, that they are held in very high respect, indeed, in this country. The time was indeed, when, as a whole, American photography was immeasurably ahead of that of any other country. We have seen in the galleries in New York, Philadelphia, Baltimore, Washington, and other American cities, Daguerreotypes which were, beyond all comparison, superior to anything we have seen in this country, or in the cities of continental Europe. In the production of photographs on paper, this superiority does not, we believe, exist, but it is rather because of the advancement on this side of the Atlantic, than of any inferiority either in knowledge or executive skill in our American friends, whose productions are still inferior to none in the world, and whose enterprise, ingenuity, and skill, have largely contributed to the general advancement of the art.

THE PHOTOGRAPHIC EXHIBITION.

FOURTH NOTICE.

THE landscapes in the Exhibition, as we are told by the adjudicators of the medals, present the greatest equality of excellence. It is perfectly true that in no previous exhibition have we noticed such a large number of thoroughly good landscape photographs. Whilst, however, there is so much uniformity of excellence, we have never noticed an occasion in which the distinctive characteristics, or "manner," of each artist was more broadly marked.

Amongst the best as well as largest of the landscapes exhibited, are those of Mr. Annan, of Glasgow. In all his pictures there is much artistic feeling, and they are characterised by an amount of massiveness, vigour, and breadth, very unusual in photographs. The relief, distance, and atmosphere are also exceedingly satisfactory. Mr. Annan avoids the enormity of white skies; clouds of an atmospheric tint is present in each of his pictures, admirably preserving harmony and breadth. Mr. Annan usually prints from separate cloud negatives, and is very successful in results. An interesting illustration of a favourite dictum of ours, to the effect that results depend on the man more than the method, is illustrated in Mr. Annan's contributions. We have, amongst his pictures, tannin and wet collodion, with a singular identity of characteristics. His "Loch Ranza" (No. 258), a picture about 16 by 12, from a tannin negative, and the "Last Stooks of Harvest" (No. 152), another charming picture of similar size, are in no sense, photographic or otherwise, inferior to "Kelvin Grove" (No. 222), "Aberfoyle" (No. 182), nor "Head Waters of the Frith" (No. 257); all of which are from wet collodion negatives. The "Muirland sac Dreary" (No. 145), and "Ben Venue from Loch Ackray" (No. 108), are also two charming pictures from tannin negatives. The three very admirable reproductions produced for the Glasgow Art Union, are also exhibited by Mr. Annan, as well as some other good pictures.

Entirely differing in style from those we have just noticed, and possessing excellence of altogether another order, are the landscapes of Mr. Vernon Heath. If the last were characterized with massiveness, these are distinguished by wonderful delicacy of feeling and manipulation. These qualities have always distinguished Mr. Heath's pictures, and in this year's pictures they are present in a more than usual degree; we have very rarely seen photographs uniting so completely force and delicacy, brilliancy and softness. A large number of Mr. Heath's pictures have been taken in

the grounds of Lord Ashburton, at The Grange, in Hampshire. One frame of four pictures especially pleases us. (No. 127). The two lower pictures in this frame are as perfect as we have ever seen photographs. The exquisitely defined distance, with its reflections in the transparent water, seems rather a dream of fairyland than a photographic transcript of actual nature. No. 133, "By the Lake," is another specimen of this marvellous delicacy of treatment. The chief feature in the picture is a silver cedar of rare magnificence; and although rendered in the monochrome of the photograph, it seems modelled in frosted silver. "A Study of Ferns" (No. 143), is such a bit of foreground, the rendering of which will delight the heart of Brett or Linnell. Several of the views of Windsor are magnificent pictures. Mr. Heath has introduced natural clouds into all his pictures this year, from separate negatives, whereby an immense gain in unity, harmony, breadth, and atmosphere is obtained. His pictures have given rise to some discussion, from the fact that the clouds in many of the pictures are printed from different parts of one negative. We feel so strongly the value of the sky in making a picture, that for such a purpose we would pardon a fault more venial than this. Variety of effect is doubtless desirable, but if the clouds are obtained under the same conditions of light, and are used so as to aid the composition, and be in harmony with the landscape, we are disposed to think that the repeated and judicious use of the same negative is quite permissible.

Mr. Bedford exhibits a number of his Eastern views, which we have already noticed, and a few other, of landscapes and interiors in this country. All his pictures have gained immensely by the introduction of skies. Perfect as the photography always was, and characterized as it was by artistic feeling, the harmony of some of his pictures was in former years impaired by the white paper sky. Now we find always a tint or clouds. Mr. Bedford adopts the method perfectly successful in his hands, of painting clouds occasionally at the back of his negatives. In less skilful hands such an attempt would fail in producing good results. But here we never dream of questioning its legitimacy, and we think it a noteworthy circumstance that pictures so treated secured the prize for landscape excellence. It would be difficult to select from these contributions any one excelling the whole, and all are pre-eminently characterized by softness, completeness, and harmony.

Mr. Henry White, amongst the earliest artistic landscape photographers, still preserves his position. Every picture is chosen with an artist's eye, and the photography is in all cases good; although in one or two instances the harmony is disturbed by a white sky.

Mr. J. Spode, who generally sends some good pictures, has some very fine landscapes indeed at this exhibition. His "Harlech Castle" (No. 256) is a most charming photograph.

Mr. Dixon Piper contributes some very excellent photographs, many of which we have, however, seen before. His "View near Rokeby" (No. 75), is especially fine.

Mr. G. S. Penny exhibits some very fine pictures from negatives taken on plates prepared with tannin and malt. "Tintern Abbey" (No. 170), is a very fine picture, with some well managed clouds. "On the Wye, Chepstow" (No. 362), is also a charming photograph.

Mr. Baynham Jones exhibits some good tannin pictures, one of which is hung near the fireplace, but not numbered, and is worthy of remark from its similarity to the pictures by the panoramic lens in shape and size. It is apparently about eight inches long and three and a half deep, and is taken with a Dallmeyer No. 1 triple lens. The effect for many subjects is very good.

Sir A. K. Macdonald exhibits a view of "Antis Cove, near Torquay" (No. 269), which is very fine, and possesses some fine natural clouds, apparently produced at the same time as the bold foreground of sea and rock.

A picture by Mr. A. S. Fisk deserves attention for the same reason. It is a view of the "London Extension Rail-

way Bridge, Battersea," and besides being a good picture, possesses some fine natural clouds.

Mr. F. C. Earl contributes some of his large views of "Witley Court," which have been exhibited before, but now have the effect of new and better pictures by having good skies printed in. Some large interiors of the same building are remarkable, as illustrating the depth of focus yielded by the triple lens, and as showing the advantages of a coating of honey with wet plates, where long exposure is necessary. These, notwithstanding the large size of the plates, are very brilliant, perfect, and clear.

Mr. Stephen Thompson's "Durham Cathedral from the Wear" (No. 176), is a fine picture, as are also some of the views of the "Abbey, Lindisfarne."

There are some other landscapes more or less worthy of notice, for which we have not space at present.

PRINTING DIFFICULTIES.

BY A PHOTOGRAPHER'S ASSISTANT.

THE necessity for an observance of a definite and more clearly understood rule in chlorodising albumen, is strikingly perceptible in the samples of slightly albumenized papers now in the market, the ever varying colour yielded by those papers has hitherto been considered the results of the acid or alkaline sizing employed in their manufacture. I think a little observation would convince the most sceptical that the sizing has but little, if anything, to do with it, that, in fact, the changes are caused by the changing influence of the light employed in reducing the silver salts; if the sensitive surface of a slightly albumenized surface is exposed to a dull light, the results are directly opposed to those observed in the highly albumenized samples; the former will yield prints of a bold blue tone, because the excess of chloride salt is most sensitive to light, and for this reason will reduce most rapidly, so that the print has attained the necessary depth ere the albuminate of silver has been acted upon to any extent. This extra sensibility is, doubtless, by some photographers considered an advantage; I am inclined to believe it is not, for whilst the chloride salt is the most unstable, and consequently requires deeper printing, the absence of the necessary proportion of the albuminate is liable to mislead us, however careful we may be in conducting toning operations, for this deep violet colour will oftentimes cause the prints to be removed from the toning bath ere it has gone the necessary depth to resist the reddening influence of the fixing solution.

Do we require proofs to convince us that the albuminate of silver remains unreduced in a dull light? If sceptics to this doctrine exist, let them place their printing frames in a shaded corner, if the paper employed be of coarse texture, and slightly albumenized, except the quantity of chloride salt is unusually small, the print will assume a blue or violet tone. Now let the frame be removed, and exposed to a brighter light, and speedily this cold tint will change to a bright and warmer hue. Why? because a reduction of the albuminate of silver has been effected, and a satisfactory print is the result. Now, had a more judicious salting been observed, the quantity of chloride of silver present would not of itself have been sufficient to give the necessary depth to the picture, and consequently the assistance of the albuminate would be needed, to produce the necessary depth of printing, or at all events, the print would contain a larger portion of the last named salt, the reducing action would move slower, but the improved results would make amends for loss of time.

In highly albumenized paper, the printing proceeds too slowly, because the albuminate is in too great an excess; whilst the slighter coated samples, in a dull light, print too rapidly, because the excess is in favour of the chloride salts. Hence we see the necessity of a series of well conducted experiments in this direction, to determine the proportion one should bear to the other, in order that the best results

may be arrived at. Some may here feel disposed to inquire the reason why lightly albumenized surfaces should contain a larger proportion of the chloride of silver than the highly-coated samples? Simply for this reason—the greater the fluidity of the albumen, the stronger its penetrative and diffusive power, and it follows that it extends itself over a larger surface than the thicker fluid can possibly do; it permeates the interstices of the paper, thus increasing largely the area of surface, and its every atom of chlorine is brought into immediate contact with the silver; and this is sufficient of itself to guide us in operations of sensitizing. A bath too strong is oftentimes an unsuspected cause of failure; the paper becomes saturated, and bears in its surface even to the closing of its pores a large amount of free nitrate. When this occurs the print bears a mealy appearance when removed from the printing frame. The chloride and albumen salts have been reduced, but the nitrate of silver continues in an unreduced condition; the finely-divided atoms extended over the entire surface of the picture, giving it the appearance of a flour bag having been shaken upon it.

And now for a word or two concerning the strength of sensitizing solution required. I stated in the early part of this paper that an 85-grain solution was required for highly-coated papers. With the slightly albumenized samples no advantage is gained by using a bath too strong; from 60 to 65 grains per ounce, is ample and most safe in working. To go beyond that quantity renders it necessary to float but a short time, say from one to three minutes. This method may do for the thoughtful printer that studies the requirements of his paper; but for the amateur, whose experience is small, it is dangerous, as he either nervously withdraws the paper too soon, or he leaves it too long, and thus engenders mealiness with the strength above named. A little over-floating makes no difference in results.

And now concerning water employed for washing, I would counsel all who value satisfactory results in their printing operations, avoid rain water that has been deposited in a tank; use spring, well, or any other clean waters that are fresh, but avoid rain water, however tempting its appearance, insidious organic poison is lurking in the crystal goblet which will insinuate itself into the affections of the silver the surface of your paper contains; and then with weary dejectedness you will watch the changeless prints as they float on the placid bosom of your toning solution, and as the old brass clock strikes at the expiration of each fleeting hour, the chloride of gold solution will again and again be added, moving the prints—yes, moving them more swiftly towards the mealy destruction the organic poison from the first had consigned them. If the printer would avoid this evil, and any trace of it crosses his path, let him suspect his water. Change it for another sample; for evils created by water are the easiest to be rid of; and now, in conclusion, I would observe my object in writing is to endeavour to rid the art of photography from empiricism; I wish to see its principles thoroughly understood; in a word, I wish every practitioner of our art to know the causes of success as well as the reasons of failures, and I see no reason why a space in the PHOTOGRAPHIC NEWS should not be set apart for discussing the causes of success in every branch of photographic art; if this plan was adopted, and photographers would assist the Editor in his arduous duties, our art would, I am convinced, be greatly improved by the practice.

ON IRON DEVELOPING SOLUTIONS.

BY M. MC A. GAUDIN.

I HAVE undertaken, as promised, a fresh examination of the proto-salts of iron, other than the proto-sulphate, for the development of negatives. This time I have had a certain success, which I hasten to communicate to my readers.

The salts of iron, at the minimum of oxydation, possess of themselves alone every degree of reducing energy which we encounter in the series of organic substances with a carbon

base, and each of these salts exhibits behaviour which depends on the nature of its acid.

The proto-sulphate, so much used at the present day, is distinguished by the fineness of the details it gives, and the sensitiveness it produces, but it rarely gives sufficient intensity which necessitates strengthening. The proto-nitrate and the proto-acetate give at once pictures of the greatest intensity; but the half-tones are often defective; the difficulty consists in their giving a sensitiveness as great as that inherent to the employment of proto-sulphate of iron.

In order to avoid their preparation by double decomposition, which is always tedious, expensive, and irksome, I have attempted to prepare these salts in a direct way with iron and the acids; and I have been very successful.

To prepare proto-nitrate of iron, it suffices to digest during four and twenty hours iron in a fine state of division, in nitric acid, diluted with *ten parts of weaker*. It thus forms, after being shaken from time to time, an olive green liquid when viewed by reflected light, and deep red by refracted light. This is the proto-nitrate of iron ready for use.

To prepare the proto-acetate, according to the same process, we take the concentrated acetic acid of commerce, and promote the reaction by a gentle heat which manifests its action by the disengagement of an infinity of microscopic bubbles, due to the decomposition of the water. This action is very slow, but little by little the liquid assumes a wine-red tint, and at last becomes as red as blood.

While these salts are forming, it is necessary to test them, in order to stop the reaction at the opportune moment. To this end we soak some pieces of ordinary white paper in the solution of nitrate of silver used for sensitizing, and after having submitted them to the action of light until they just begin to turn yellow, we place them near the salts in course of preparation, to make them serve as tests, which is done by touching these papers with a glass rod dipped into the solution. At first, the salt in which acid predominates discolours the paper, especially the proto-nitrate; but gradually the salt becomes a reducing agent, and makes a black mark on the paper. When the blackening appears very distinctly, the salt has attained its maximum of reducing power, but it may be too strong. To make sure of this, it must be submitted to a reverse test. After having diluted the salt with four or five parts of water, as if it were to be employed for development, we take a glass rod moistened with it, and touch a piece of the silvered paper that has not been exposed to light. In this case, the paper must not become coloured in less than five or six minutes. If a black colour appears immediately, which often occurs with the proto-acetate, the salt must be aerated, or some drops of nitric acid added, to oxygenate it, for, in fact, as I have many times repeated, the efficacious salts of iron are the oxydule salts, and not those of the protoxide. The instantaneous blackening of the nitrate of silver bath, which I have before attributed to an organic matter derived from the acetic acid, has no other cause; in every case we can remove this impediment by a gradual addition of nitric acid, followed by aeration.

The proto-sulphate and the proto-acetate of iron have a tendency to make the developing solution muddy during the developing, which the proto-nitrate does not. I fully believe that this is due to a double decomposition ultimately produced: there is the formation of insoluble sulphate and acetate of silver, which are reduced to the nascent state, while between the nitrates this phenomenon does not occur.

The essential characteristics of the proto-nitrate are, the slowness of its reduction, the constant limpidity of the liquid, and the pushing to an intense black, which is permanent; but, on the other hand, the most delicate half tones are wholly wanting; and this is just what remains to be attained. For example, after having sensitized a small plate and having placed at its back a piece of red or yellow glass, if we expose the plate to light for a few seconds, and then develop it, the profile of the coloured glass will detach itself perfectly pure and clear upon a black ground of the greatest intensity, and in this clear portion, at the end of ten minutes, the iodide

of silver will have become insensitive to light, for we may pour upon it in the open air some nitrate of silver mixed with proto-nitrate of iron, and double the intensity of the black without sensibly dimming the light portion.

While we cannot obtain the half-tones by development with proto-nitrate of iron; this salt is found, by the same fact, superior to all others for certain purposes; for example, the negative of an engraving is composed of lines or points, more or less distant from each other, *but all of the same intensity*; the blacks cut sharply on the whites. With the proto-nitrate of iron, the blacks will not send sufficient light to impress, while the whites will work themselves upon the negative in a black of an intensity proportionate to the duration of the exposure. This does not take place with the proto-sulphate and pyrogallic acid, which seldom gives skies fit for printing, without some additional coating.

The proto-acetate is intermediate between the proto-sulphate and the proto-nitrate; it gives a bistre tint of the greatest beauty, the intensity of which is exactly proportionate to the duration of the exposure; but it, at the same time, gives half-tones; and from the day when it gives them as faithfully as the proto-sulphate of iron, it will be the developer *par excellence*, because it keeps very well in a corked bottle, when concentrated, and it is sufficient to dilute it with four or five parts of water to have it always ready for use.

By adding an imperceptible quantity of ordinary sulphate of iron to a proto-nitrate that works well, we succeed in making it act quicker; this is useless with the proto-acetate, which works quick enough. I have thought of employing these solutions in a warm state, but this deviation produced the worst results at every increase of temperature; for, these developers are of an excessively delicate nature.—*La Lumière*.

AN APOLOGY FOR ART-PHOTOGRAPHY.*

BY O. G. REJLANDER.

SOME time ago you did me the honour to elect me an honorary member of this Society. I felt it to be an honour, and take this opportunity of returning you my warmest thanks for the distinction.

I have diligently read the reports of the meetings of the South London Photographic Society, and find that there is no branch of photography with which you are not thoroughly conversant. What has pleased me most in your proceedings has been the earnest interest you have shown, and the encouragement you have given, in raising the science we practice to the dignity of a fine art. Such course, however, has been much misunderstood by friends and foes, and as I am an old sinner in that direction I have come forward to be the "horrid example," show my complicity, and present AN APOLOGY FOR ART-PHOTOGRAPHY.

In doing so allow me, in the first place, to explain how I first tumbled into photographic art, and how I have been "bobbing around" ever since, without being able to benefit myself in the way I have been preaching to others.

I had always a hope that I should be able to sit down and paint with the aid of those photographs that I had invented, and grieved I have often been to send out gems for others to paint from; but the fact is that my experiments have cost me so much, and my *clientèle* been so small, I have never been able to get the upper hand. Commercially, the cost has been to me sometimes more than what I earned; and it is impossible to have a painting in hand—a lone man—and run backwards and forwards from the camera to the drying pallet; so I must stick to the camera for my living, though in my own way.

In 1852 I was in Rome, and saw photographs of the *Apollo Belvidere*, the *Luocoon*, the *Torso*, Gibson's *Venus*, &c., &c., which I bought and studied; and I was delighted to have a fair chance of measuring the relative proportions of the antique on the flat and true copies of the originals. That was my first acquaintance with the fair results of photography. I merely recollected having seen some reddish landscape photographs the year before at Aekermann's, in Regent Street, but these made no impression on me. What I saw in the Exhibition of

* Read at a meeting of the South London Photographic Society, Feb. 12th, 1863.

1851 had proved as evanescent as looking at myself in a glass—"out of sight out of mind." They were all Daguerreotypes, and awakened in me at the moment nothing but curiosity. But in Rome I was fairly taken with the capabilities of the art, so I made up my mind to study photography as soon as I returned to England.

My view at this period, to the best of my recollection, did not extend farther than showing me the usefulness of photography in enabling me to take children's portraits, in aid of painting, and for studies for foregrounds in landscapes.

In 1853, having inquired in London for a good teacher, I was directed to Henneman. We agreed for so much for three or five lessons; but, as I was in a hurry to get back to the country, I took all the lessons during one afternoon!—three hours in the calotype and waxed-paper process, and half-an-hour sufficed for the collodion process!! He spoke, I wrote; but I was too clever. It would have saved me a year or more of trouble and expense had I attended carefully to the rudiments of the art for a month.

It is curious to notice how frequently trifles decide some men's actions. What really hurried me forward was my having seen the photograph of a gentleman, and the fold in his coat sleeve was just the very thing I required for a portrait I was then painting at home, and could not please myself in this particular point. My sitter had not time or inclination to sit for it; my lay figure was too thin (I soon sold that); but this was just "like life!" "Now," said I, "I shall get all I want." I could not exercise proper patience. I therefore took all the lessons at once, to turn out as a ready-made photographer the next day. Alas! for a very long period my attempts at photography resembled those of a young Miss at the piano, looking alternately at the music and the keys. If I had to speak at the time of operation, I very easily went wrong—often drawing up the shutter of the plate-holder with the collodionised plate outside.

I wish here also to add my acknowledgment that in my early photographic education my guide and comforter was Professor Hunt's Manual—that, even then—contained the germs of most of the processes since enlarged upon.

I cannot forbear mentioning that some of the earliest portraits that I took, and which I had sensitized with ammonia-nitrate, are as vigorous now as they were then, although they had but three changes of water—ten minutes or a quarter of an hour in each dish after hypo, as my instructor had told me—while others and later, according to the usual process, have proved as treacherous as a bad memory. At length Maxwell Lyte let his light in on my manipulations by the publication of the alkaline gold-toning process. At that time I was nearly giving up photography. I felt as if I were only writing in sand.

My first attempt at "double printing," as some call it, was exhibited in London in 1855. It was named in the catalogue *Group Printed from Three Negatives*. That plan I hit upon through sheer vexation, because I could not get a gentleman's figure in focus, though he was close behind a sofa on which two ladies were seated. Up to this time I considered postures on the principle of *bas-reliefs*—that is, with as few foreshortenings as possible; but now I felt freer.

I will now tell you how I first drifted into [making photographic pictures; and it seems to me that any one might excuse me—even Mr. Sutton—after hearing it. I had taken a group of two. They were expressive and composed well. The light was good, and the chemistry of it successful. A very good artist was staying in the neighbourhood, engaged on some commission. He called, saw this picture, was very much delighted with it, and so was I. Before he left my house he looked at the picture again, and said it was "marvellous;" but added:—"Now, if I had drawn that, I should have introduced another figure between them, or some light object to keep them together. You see there is where you photographers are at fault. Good morning!" I snapped my fingers after he left—but not at him—and exclaimed aloud, "I can do it!" Two days afterwards I called at my artist-friend's hotel as proud as anybody. He looked at my picture and at me, and took snuff twice. He said—"This is another picture." "No," said I, "it is the same, except with the addition you suggested." "Never!" he exclaimed; "and how is it possible? You should patent that!" * * * Well, our interview ended with another suggestion that if a basket or something else had been on the left side in the foreground it would have given greater depth to the picture, and adding that the light dress of the female on the shady side was not shady or dark enough. I agreed fully with my friend's criticism; and, after a week, I

sent to him, to London, the picture amended as at present. He wrote some time afterwards and thanked me, saying that it was very successful; but (he wrote), of course, now that that was known, any one who practised photography could do it.

* * * This was my first sip at the sweet and bitter cup in my photographic career.* A thought of the share he had in this first effort in composition-photography did not occur to my friend. I should very likely not have done it but for his "you can't!" Now why should this cause all the fuss and abuse for interfering with legitimate art? To me double printing seems most natural. Vignetting is allowed and admired. The manual part of photographic composition is but wholesale vignetting. It has proved most useful in portraiture when a family group was to be taken; for if one figure moved, he or she could be taken over again alone, and put in afterwards; or, what is still better, a sketch of the group may first be made, then take each figure separately—for then each would be more perfect—and print them in agreeably with the sketch.

But please to believe that I did not look upon photography as an ultimate art, or an art depending on itself, or complete in itself, except details; though I can guess of its extended applicability, or rather plasticity. In almost all the art-studies I have made, I have had one object in view—they were for the use of artists; and if I had not done them, how could artists, who are not acquainted with photography, know what could be done? They know now, and they avail themselves of it.

But as there is no mind in the photographic picture, so according to some it cannot contain any new idea, pose, light, or expression capable of representing impressions produced on the human mind, and "not being the work of man," it must be, indirectly, the work of the devil—and, since as "the work of man is indirectly the work of God," as Mr. Sutton has it, where are we to go to?

Still I think highly of photography. It is fair, open, and above-board. There is no sham about it—no pretensions to anything that is not discernible. And the world wouldn't be without it, in all its branches—including the one I most practise, art-studies and details from the life. Though to me this branch of the art is unprofitable, yet it gives me pleasure. I live in it, if not by it. As to those dreadful composition photographs, I have only executed one since the "abominable" "Two Ways of Life," and that one I meant as a set-off to the other, and called it the "Scripture Reader;" but that was neither good nor bad enough to attract any notice whatever. I have not exhibited for some years, so I think I might have been let alone.

I have been so ill-used and abused about the picture, the "Two Ways of Life," I should be glad to once more—not describe it, as I did to the Central Society—but explain that it was dedicated to English artists, which dedication was written under the one exhibited at the Manchester Exhibition;—not as a challenge, for that would have been ridiculous, but to show various studies from nature, which at that time were rather novel. And again, as the most difficult drawing is that from the living model, I presumed thereby to point out a handmaid to art—not alone in full light, but in shade—yet transparent. Each figure was meant as a specimen of variety of light and shade. I dislike a mere nude, if it (apart from study) conveys no idea. So I brought all the figures together as well as I could, and gave the resulting picture a name. This composition was also meant to show that there might be a little real sun-painting employed when needed, to harmonise or soften harsher light in photographs. These are indeed no after-thoughts.

I will not tire you with further description. Those that objected to the "Two Ways of Life" being exhibited had a perfect right to their opinion; but they have no right to ask the names or profession or religion of models, still less to use vile epithets in speaking of them, as Mr. Sutton has done in his paper read before the Photographic Society of Scotland. When children are inconveniently inquisitive, we tell them they were "found in a parsley bed;" and a similar answer might be given to those who cannot or will not comprehend the matter. There are many female models whose good name is as dear to them as to any other woman. But I prefer to believe that Mr. Sutton did not use those harsh expressions on mere supposition; but that he may have been misinformed, in his search for the truth, by those who wished to increase their attraction by saying

* It is not difficult to understand the vague notions of an artist the first time he sees such a thing accomplished—such a result in so short a time—when compared with his own laborious method.

that they had been models for Mr. So and So; for I have been told that that is not an uncommon practice. Of course I need not be ashamed to say I have heard it.

Mr. Sutton is a very hasty writer, and is often wrong in consequence; yet he is always frank enough to admit his error when convinced that he is wrong. This opinion is formed on my long reading of the "Notes," to which I have been a subscriber from its first publication, until I removed to London, when I missed it, or it has missed me, owing to my having forgotten to send my new address. I have always found the "Notes" full of promising information.

It is very hard—but I must confess it—that I positively dare not now make a composition photograph, even if I thought that it might be very perfect. I have brought with me a sketch over which I have thought for a very long time. Up to this moment it is a work of art. Is it not? The same way a painter goes if he means to paint a photographer must go if he wishes to make a composition-photograph. The two go together—part here, and meet again.

Fine art consists of many parts; and a photographic composition commenced in this manner must contain many parts in common with art; and even where they part company photographic art does not stand still, but proceeds and gathers other merits on another road—though a more humble one, yet full of difficulties, requiring much thought and skill up to the last moment, when they again converge, in the production of light, shade, and reflected lights which have been predetermined—in general keeping and aerial perspective.

There is no valid reason for saying that, because you have not seen a good photographic composition, there could not be one. I believe there can be produced—even after all that has been done—wonderful pictures by photography. And why are there no good art photographs? Because it requires art and long training to execute them, beside encouragement. I do not believe in haphazard excellence. Photography, in my opinion, is essentially excellent for details. You may take twenty good figures separately, but they cannot be taken at once. You cannot take even four good ones at once; but then you cannot draw or paint a picture at once.

I believe photography will make painters better artists and more careful draughtsmen. You may test their figures by photography. In Titian's "Venus and Adonis," Venus has her head turned in a manner that no female could turn it and at the same time show so much of her back. Her right leg also is too long. I have proved the correctness of this opinion by photography with variously-shaped female models. In "Peace and War," by Rubens, the back of the female with the basket is painted from a male, as proved by the same test.

The real good old painters—such as Raffaele, Leonardo da Vinci, Luini, Velasquez, Teniers, Titian—you often find reflected in photography in apparent finish and effect. I can exemplify presently what I mean by the photographs which are now before you.

There are many ways in which photography can prove useful to artists, although few of them are aware of it. Here is one:—After they have made their sketch, or uncoloured cartoon, they may have a photograph taken from it; and then on the prepared albumen paper they may play with colours as much as they like, until they arrive at what they wish for their painting; for a wet brush removes any colour objected to, just as if it had never been there, yet the outline underneath remains the same.

One of the reasons why painters are troubled in using a photograph to print from, is that almost in every case (I am now speaking of portraits or figure pictures) the light on the photograph is different to that on the sitter at the artist's studio. Here is a source of confusion and vexation. I have often felt it, and wished that I had not looked at the photograph; yet it saved the time of the sitter. But if a photographic study is taken in a light similar to that at artists' studios generally, and that be enlarged, if the artist gets the same model or sitter into his own studio, the work is only pleasure.

I think picture-dealers are, or have been, from interested motives, the greatest opponents to photography, and they have great influence. As to art-critics, they vary so much in their opinion from one year to another, and differ so much between themselves, I am induced to conclude that they write generally from the information they have received from persons they trust to; for I believe if they possessed even the data that we have, they would be more Christian like—rather help with their criti-

cism than damn with their sneers. Though individually I must not complain much. I have had praise, and I was silent. Lately the tables have been turned, and from a "successful delineator," &c.,—happy in catching transient expressions—I had come down to be a "clever operator," when recently I was reduced to the position of a "manipulator" in a notice—and such a notice!—in the *Athenæum*, of an allegorically-treated photograph of "Garibaldi Wounded, Supported by Hope, Pointing to Rome." My intention in this photograph was to show that my opinion of the hero was that he never would give up the idea of possessing Rome. But in the notice in the *Athenæum** above alluded to, I was rudely taken to task. It was intimated that I had paid my model 1s. 6d. per hour, when I myself was the model, and never realised 6d. per hour! After my many days' trials, and heavy printing expenses, my publisher ceased to order immediately upon that veto being placed upon the picture. I hoped to have secured an adequate return from its publication: I never had a catchpenny yet. But what angered me most was that the critic called the photograph indecent! I cannot guess in what.

A funny thing it is that some people actually prefer the chalkings of a boy on the walls and shutter to the finest photographic pictures! Just think how superior are the mackerel and ship at sea we find drawn on the pavement in coloured chalks! I am ambitious, too!

I have here a picture,† in which I have attempted to draw something, like a good boy, and beg the Chairman's acceptance of it. I only wish there had been another sunny day, to have enabled me to have made it more perfect. It is a real sun-painting, or rather it has been painted by me with pencils of light about ninety-three millions of miles long! and the points varying considerably. I exposed it so much to diffused daylight for want of sun, that I have been obliged to take up some lights still that have been done chemically by the cyanide of potassium. When I painted it I almost imagined I heard its notes whistling.—Now, USE PHOTOGRAPHY; DON'T ABUSE IT.

THOMAS SUTTON, B.A., ON ART-PHOTOGRAPHY.

BY ALFRED H. WALL. ‡

SAITH Atticus—"Let every man enjoy his own spouse;" and I have no reason on earth for denying every man his right so to do, providing only that such spouse be quite legitimately his own.

But the man who enjoys one spouse while he has another living I conceive that I have a perfect right to denounce as guilty of no less a crime than bigamy; and that, gentlemen, as your worthy Treasurer will inform you, is against the law.

Before this bar of public opinion, and in the interests of one of two spouses thus enjoyed, I therefore charge Thomas Sutton, B.A., editor of the *Photographic Notes* with flat, downright, open and avowed bigamy. For that, whereas, up to the year 1860, he had openly announced himself as wedded to *Art-Photography*, he in that identical and aforesaid year did publicly espouse *Mechanical Photography*. And in support of this charge I beg leave to introduce the following witnesses:

My first witness is a valuable little work on "The Positive Collodion Process," written by Mr. Sutton in 1857, which says—*"Photographic portraiture is not a mechanical art. It involves the application of certain principles of art."*

My next witness is the *Photographic Notes*, dato 1860, which very wisely remarks:—"Although photography is certainly a mechanical means of representing Nature, yet, when we compare a really fine photograph with an ordinary mechanical view, we are compelled to admit that it exhibits mind, and appreciation of the beautiful, and skill in selection and treatment of the subject on the part of the photographer, to a degree which constitutes him an artist in a high sense of the word."

My third witness is a number of the *Photographic Notes* published in 1862, which remarks of the productions of T. R. Williams, that "sentiment and grace" are infused into them by the artist, and that to such an "extraordinary extent that they are quite undistinguishable from the fine works of art."

Here, then, we see Mr. Sutton holding within his fondly-encircling arms the first love of his fickle heart,—Art-

* "I wish I was in Dixie! I do! I do!"

† A donkey's head, drawn by light alone, guided by me.

‡ Read at a meeting of the South London Photographic Society, on Thursday Evening, Feb. 12th.

photography—recognized, as we see, in 1857, and not disowned entirely in 1862.

To prove the existence of the second "spouse," and that she was wedded before any legitimate separation had divided Mr. Sutton from his first spouse, is the business of my next following witnesses.

Witness No. 4 is a number of the *Photographic Notes* for September, 1861, and says—"Photography has its peculiar value as a handmaid of the fine arts, but it is not one of them." This witness, moreover, gives as a reason for such a conclusion, that "the essence of art is to suppress coarse particulars," which "the camera has no power of rejecting;" and that if the photographer removes these "coarse particulars" so that the camera can have no power of recording them, although the photographer is then admitted to be an artist, still photography is not art.

In dismissing this witness, I would, if the poor thing were not already sufficiently confused, commence a cross-examination to discover how the man could be an artist by virtue of works not the production of an art.*

Witness No. 5 is a paper by Mr. Sutton, read before the *Photographic Society of Scotland* on the 13th of January, 1863, which completes my case by asserting that "the first chalk drawings of a school-boy on a wall are" (in the opinion of Mr. Thomas Sutton, B.A., &c.) "more admirable, from the human interest which they possess, than the finest view of inanimate natural objects upon the ground-glass of a camera-obscura.

As I am not in possession of more than a few numbers of the *Photographic Notes*, and have not time to look carefully through even the few I have, no more witnesses will be called, although I have in remembrance the words of many others capable of giving even more conclusive evidence than that I have advanced. Still, I believe the case, even as it here stands, will be found tolerably clear and conclusive, and that the verdict will be in accordance with the evidence and with truth.

To quit joking, however, I wish to tender a few remarks concerning a paper written by Mr. Sutton, "On some of the Uses and Abuses of Photography," or rather upon that portion of it which refers to the so-styled "abuses."

Mr. Sutton commences this portion of his paper by saying that everything in the way of composition photography which he has seen, by Messrs. Robinson and Rejlander, "has been a failure, and has afforded increasing evidence of what every true artist knew before to be impossible and opposed to correct principles. What you want in a work of art" (says Mr. Sutton) "is not an exact and truthful resemblance of a group of natural objects, however cleverly arranged and lighted, but a reproduction of such objects, or a new combination of such objects, according to impressions that they have produced on the human mind."† And then follows that truly remarkable paragraph to which I have already referred, concerning the school-boy's first chalk drawings on one of my more illustrious namesakes.

The question thus stated by Mr. Sutton simply resolves itself into that old, old question on which artists and artistic critics have themselves been divided for very many years past. Long before photography was dreamt of in our philosophy, the degree and character of truth which ought to be embodied in the highest aspirations of art were a source of continual discussion and contention in all the various schools. But in none of these schools however strong party influence or feeling might run, was there ever found an advocate for the ideal in art so extravagant as to assert of truthful art that it was not art at all. This has been reserved for Mr. Sutton.

But the question of artistic *versus* mechanical photography will never be decided on these grounds of the real and the ideal. Upon the evidence afforded by simple truthfulness of imitation, photography can neither be denied nor awarded a place among the fine arts. Every art which aspires to the distinction implied by the term "Fine Art," must base its claims upon the amount and degree of intellectual power of which it can be made the vehicle. If we find that photography can convey as much of the artistic intellect into the minds of spectators as any other art called "fine" has the power of doing, then, and then only, is photography a fine art. By this test I ask that photography shall be judged; and if such works as those of Rejlander and Robinson be allowed to plead in the minds of competent

and unprejudiced witnesses, I have little fear of the decision which must be arrived at.

On this subject of true and ideal art I know no one who has said more in fewer words than that eminent and high authority, Mr. Ruskin, has done in the following:—"Every alteration of the features of nature has its origin either in powerless indolence or blind audacity—in the folly which forgets, or the insolence which desecrates, works which it is the pride of angels to know and their privilege to love."

In contrast with this noble sentiment of a humble and reverential love for the works of the Divinity, emanating from the soul of a true artist, let us place the following, uttered, in the paper I have mentioned, by Mr. Sutton:—"God created these objects and He also created man; and man's works are therefore indirectly His works. But man is the noblest creation of the Deity; and if you follow up the train of thought you will see that pictures which are the result of human imagination, observation, and powers of imagination* are more noble and belong to a different class of things altogether from the images in a camera-obscura.

I must confess that any clue to the train of thought Mr. Sutton here refers to is, to me, perfectly invisible; for I cannot of course conceive that Mr. Sutton is so blindly audacious, so forgetfully foolish, or so sacrilegiously insolent (to give Mr. Ruskin's words their legitimate application) as to claim greater superiority for the works of man than for those of God, as represented in all their glorious perfection on the ground-glass of the camera-obscura.

Putting aside the abstract question of reality and ideality, then, as being no concern of ours (for I cannot conceive that even Mr. Sutton would deny the claim of the minutely and quite photographically truthful paintings of the Dutch school to be considered works of art), let us turn to Mr. Sutton's attack upon photographic studies from the nude, which runs as follows:—

"When the Council of this Society [the Photographic Society of Scotland] some years ago, banished from the walls of its exhibition a photograph entitled 'The two Ways of Life,' in which degraded females were exhibited in a state of nudity, with all the uncompromising truthfulness of photography, they did quite right, for there was neither art nor decency in such a photograph; and if I expressed a different opinion at the time I was wrong. There is no impropriety in exhibiting such works of art as Etty's 'Bathers Surprised by a Swan,' or the 'Judgment of Paris;' but there is impropriety in allowing the public to see photographs of nude prostitutes, in flesh-and-blood truthfulness and minuteness of detail."

The great sting of this attack is perhaps intended to reside in such terms as "degraded females" and "nude prostitutes;" but Mr. Sutton has no more right to scatter his foul words among the models chosen by Mr. Rejlander for his beautiful photographs, than he would have to apply the same coarse expressions to the models Mr. Etty painted from in producing the identical pictures he mentions. Mrs. Grundy and Mr. Sutton notwithstanding, it is by no means impossible that the very models thus publicly stigmatized as "degraded prostitutes," because they sat as studies to Mr. Rejlander, may be really respectable wives and mothers. Of course, I use the word "respectable" in its anti-Grundy sense.†

If, however, Mr. Sutton objects to the representation of nude models, simply because he imagines that they should be idealized or conventionalized, before their images are fit to be presented to what he must evidently regard as a lascivious-minded, British public, then I have another answer for him.

Canova, the great sculptor, in a letter to the Earl of Elgin, concerning those celebrated works of Greek art, the Elgin marbles, says:—"I admire in them the truth of nature, united to the finest forms. Everything here breathes life. The naked is perfect flesh, and most beautiful of its kind. I think myself happy in having been able to see with my own eyes these distinguished works, and I should feel perfectly satisfied if I had come to London only to view them." Haydon, the historical painter, says of these same glorious and unequalled productions, that, "having dissected man and animal for two years," he saw in this sculpture "every tendon, bone, and muscle distinguished from each other in substance and shape, and always indicated where nature indicated them;" and adds that, therefore, "it

* "It—the camera—treats everything alike, and if the man interferes and alters the arrangement of things that nothing objectionable shall be presented to the camera. His art consists in making that arrangement, and not in afterwards taking a photograph of it."—*Notes* for September 1st, 1861.

† These italics are Mr. Sutton's.

* The italics are Mr. Sutton's.

† In reading this, it must be remembered that the writer is an artist who has himself studied from the nude, and is, therefore, familiar with the general characteristics of artists' models.

was nothing but natural that he should at once recognise their superiority to all other sculpture, because in no other sculpture was this system of nature so distinctly clear." Enthusiastically dwelling upon their truth and beauty, poor Haydon added, that he "would joyfully have died in their defence." Hazlitt, the popular art-critic, says of these same miracles of art:—"The communication of art with nature is here everywhere immediate, entire, palpable. The artist gives himself no fastidious airs of superiority over what he sees. He has not arrived at that stage of his progress, described at much length in Sir Joshua Reynolds's discourses, in which, having served out his apprenticeship to Nature, he can set up for himself in opposition to her. . . . We can compare these marbles to nothing but the human form purified; they have every appearance of absolute *facsimiles*, or casts taken from nature. . . . Let any one, for instance, look at the leg of the *Ilissus* or *River God*, which is bent under him: let him observe the swell and undulation of the calf, the inner texture of the muscles, the distinction and union of all the parts, and the effect of action everywhere impressed on the external form, as if the very marble were a flexible substance, and contained the various springs of life and motion within itself, and he will own that art and nature are here the same thing." Referring to some advocates of the ideal in art who urged that in the *Elgin Marbles* the real and the ideal are only combined with very extraordinary skill, Hazlitt replies:—"If by *ideal forms* they mean fine natural forms, we have nothing to object; but if they mean that the sculptors of the *Theseus* and *Ilissus* got the forms out of their own heads, and then tacked the truth of nature to them, we can only say, 'Let them look again! let them look again!' We consider the *Elgin Marbles* as a demonstration of the impossibility of separating art from nature, without a proportionate loss at every remove. . . . The truth of nature is incompatible with ideal form, if the latter is meant to exclude actually existing form." This same able art-writer then goes on to say:—"That truth of nature and ideal or fine form are not always, or generally united, we know; but how they can ever be united in art, without being first united in nature, is to us a mystery, and one that we as little believe as understand."

To make the illustration thus supplied by a writer of position (speaking, it must be remembered, before photography existed) the more remarkable, I shall give one more quotation, in which Hazlitt writes:—"Suppose, for illustration's sake, that these marbles were originally done as casts from actual nature; and then let us inquire, whether they would not have possessed all the same qualities that they now display, granting only that the forms were in the first instance selected with the eye of taste, and disposed with knowledge of the art and of the subject."

This inquiry is most conclusively answered in the affirmative. "Incontestably there would have been, besides the same grandeur of form, all the *minutiae* and individual details in the cast that subsist in nature, and that find no place in *ideal art*. . . . The veins, the wrinkles in the skin, the indications of the muscles under the skin, the finger joints, the nails, even the smallest part cognisable to the naked eye, would be given with the same prominence and the same subordination. . . . Therefore, so far these things—viz., nature, a cast from it, and the *Elgin Marbles*—are the same; and all three are opposed to the fashionable and fastidious theory of the ideal."*

What becomes of Mr. Sutton's disgust at "flesh-and-blood truthfulness, and minuteness of detail," in the face of such proofs as are supplied by the *Elgin Marbles*, and such opinions as are here, by voices of the greatest authority, so emphatically expressed? No higher or more widely-recognized authority, and none more conclusively eloquent in favour of absolute truth in studies from the nude, can possibly be advanced than will be found in these marbles, many of which were undoubtedly, if our best records of ancient art may be relied upon, faithfully copied from what Mr. Sutton chooses to call "prostitutes," or "degraded women." Phryno, whose beauty preserved here life, courtesan though she was, has won world renown as the "Venus of Cnidos," and her golden image took its place among those "consecrated by public piety."

In conclusion, I will quote Cowley, the good old poet, to show how far from new this controversy of the real and the ideal is:—

* The author greatly regrets that he cannot here give all the powerful arguments and demonstrations by which Hazlitt urges that, even if mechanically produced, these works are the very highest and most perfect art.

"Who to the life an exact piece would make,
Must not from others' work a copy take.
No, not from Rubens or Vandyke,
Much less content himself to make it lie
The ideas and the images which lie
In his own fancy or his memory.
No: he before his sight must place
The natural and living face;
The real object must command
Each judgment of his eye and motion of his hand."

THE APPLICATION OF PHOTOGRAPHY TO THE MAGIC LANTERN EDUCATIONALLY CONSIDERED.

BY SAMUEL HIGHLEY, F.G.S., &c.*

LECTURER'S DEMONSTRATING LANTERN.—The best form of lantern for lecturers or institutions is one made in mahogany (the older the stuff, of which it is constructed, the better), twelve inches square, and twenty inches high, fitted with two jets and two nozzles, the lower one being used for lantern views, the upper one is fixed on a hinged panel, so that if a dissolving view arrangement is desired, the two discs on the screen may be made to coincide by depressing the upper nozzle by the action of a spring and screw adjustment. The upper nozzle may be replaced by a microscope arrangement, or a polariscope, and to the flange of the lower nozzle various pieces, such as knife-edge slit plates may be fitted for Spectrum Analysis, or other optical experiments. To economise space and cost of production, in place of the ordinary chimney, I use a flat dome of iron, fitted with side plates, so that by raising the dome or lid from behind, ventilation is secured, while the egress of light is prevented by the angular side-screens. Instead of the ordinary dissolving view fan, which I dispense with *in toto*, I make one view die away while the other brightens, by means of alternating gas-taps (that admit the oxygen supply), worked by a lever arm, all of which improvements are shown in section, in Fig. 10.

Fig. 10.

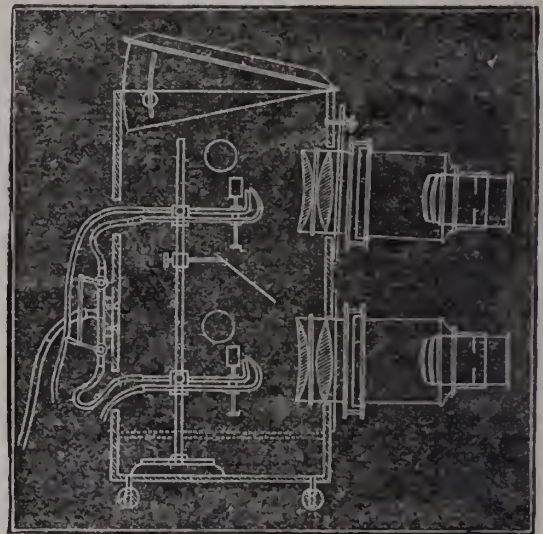

The optical parts consist of the condensers, which are formed of a meniscus and a crossed lens, and the front lenses, which should be achromatic combinations, adjustable by a tube sliding in a cloth-lined jacket, or by a rack and pinion motion.

The lenses should separate, so that while in combination they may give an obtused-angled dispersion to the rays of light, and then be used near a screen of moderate diameter, and when the back lens is removed, an acute-angled dispersion, so as to be suited for a large screen placed at a considerable distance from the lantern. By the latter arrangement, at an equal distance from the screen, a smaller, but consequently a brighter, picture is secured, as the same amount of light is not diffused over so

* Continued from p. 82.

large a surface as when the two combinations are used together.

If this lantern is to be employed by a travelling lecturer, I would suggest the adoption of an arrangement I exhibited at the International Exhibition, and which stands upon the floor; it consists of a zinc gasometer, enclosed in a wooden casing; within the body of the bell, the lantern is packed, while a case containing the jets, nozzles, &c., fits within the body of the lantern, as shewn in Fig. 11.

Fig. 11.

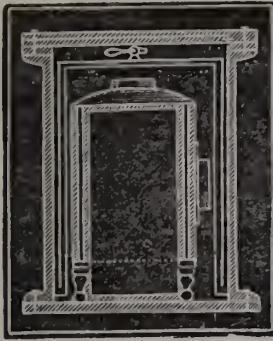

When the parts are unpacked four rods screw into the corner of the outer case of the gasometer, on to the top of these the folding lid clamps, and then forms a table for the lantern and slides as shown in Fig. 12, while the bell of the gasometer is capable of holding sufficient oxygen for an hour's lecture (or longer).

Fig. 12.

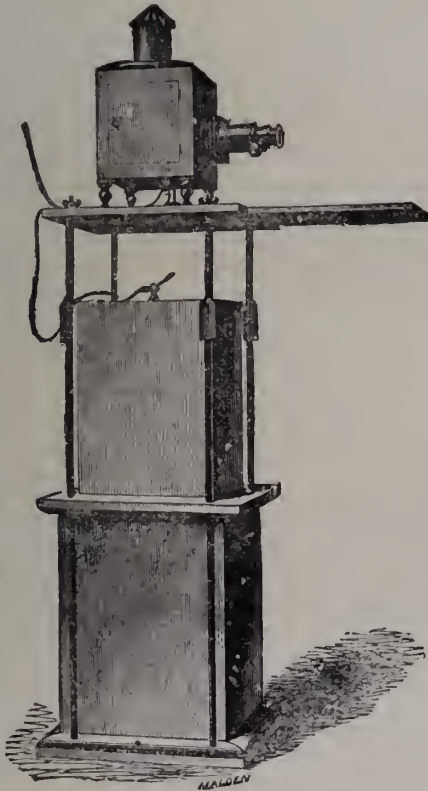

The lantern case of fittings, and gasometer, when packed, occupy a space of 14 by 15 inches square by 24 inches in height. The four iron rods strap together as a separate package.

If, however, the lantern is to be in constant use at an Institution for demonstrations, pictorial or optical, then the lecture-room stand I have devised is more convenient. By rackwork

and turn-table adjustments, the lantern placed on its stage can be centred with any piece of optical apparatus; or, when required for views, it can, by a telescopic slide in the supporting bars, be carried up to the centre of a screen five or seven feet from the ground. By turning the folding flap back at any desired angle, and placing the lantern upon it, the rays of light might be projected upwards or downwards, as may be desired, according to the way the nozzle is placed in reference to the incline of the flap-table. I do not mount my photographs in separate frames, but, to economise space, pack them in grooved boxes like those used by photographers, and employ a pair of "view-holders." These open like a book, the slide is dropped into a square cell, and on the flap being shut and clamped by a turn-buckle of peculiar construction, the view is kept firm by four springs pressing on the corners, as shewn in Fig. 13.

On a view-holder being taken from the lantern it is replaced by its fellow holder, and during the description of the subject on the screen, it is opened, the previous slide removed from its cell, dropped into its groove in the stock box, and replaced by the next subject, and the two view-holders are thus kept alternating.

With regard to screens, they may be transparent or opaque, the latter being distempred in "flatted" white by any method that prevents the surface from cracking when rolled up. Opaque screens can be made as large as ten feet in diameter,

Fig. 13.



and up to this size may be conveniently mounted, like library maps, in cornice rollers. Beyond this size, they should be constructed of calico sheeting, as they then fold into a small space for the purposes of carriage, and when mounted may be strained by strong poles jointed together like a fishing rod. The smaller screens may be supported, and strained on a portable folding stand I have designed, a model of which is placed on the table.

The advantages I claim, then, for magic lantern views, over those in general use, when educational value is aimed at, are delineations truthful to nature, and abounding in detail, cheapness, compactness, as compared with paper diagrams, and their utility in museums, when not in use for their legitimate purpose.

(To be continued.)

Proceedings of Societies.

SOUTH LONDON PHOTOGRAPHIC SOCIETY.

The usual monthly meeting was held in the City of London College, on the evening of Thursday, February 12th, Mr. SEBASTIAN DAVIS in the chair.

The minutes of a previous meeting having been read and confirmed, the following gentlemen were elected members of the Society:—Messrs. C. Smartt, T. R. Williams, J. H. Dallmeyer, T. R. Mills, Henry Squire, and C. E. Elliott.

A parcel of two-ounce bottles of bromo-iodized collodion, by Messrs. HORNE and THORNTHWAITHE, was placed upon the table as a present from that firm to the Society, each member being requested to accept a bottle. It was explained by Mr. Martin that the collodion was believed to be of unusually fine quality, and he read a note received from Messrs. Ross and Thompson, of Edinburgh, ordering six pints as early as possible, and remarking that it was the very best collodion they had used. We may here, with propriety, add that since the meeting we have tried the collodion and found it fully justify the encomiums it had received. It is very rapid, clear, and brilliant; full-bodied, giving a rich creamy film, and yielding fine half tone, clean shadows, and dense lights, the negative being in some cases

sufficiently vigorous with simple iron development without intensifying.

Mr. SQUIRE exhibited a variety of photographs illustrating the capabilities of Shepherd and Co.'s lenses, amongst which were some fine instantaneous stereographs of scenes in the neighbourhood of Plymouth. He also exhibited a novel printing frame, in which facilities existed for printing half-a-dozen card portraits on separate negatives, the arrangement permitting not only the easy examination of each, but of removing any print and negative without disturbing the others. He also exhibited a rolling press for card pictures, after the design of Coleman Sellers.

It was explained by the Chairman that the exquisite card picture consisting of a view of Edinburgh from Calton Hill, with fine natural clouds, which had been so much admired at the last meeting, was by Mr. Archibald Burns, and that some of them were ready for distribution amongst the members, in accordance with the resolution of the last meeting. He hoped that all would be ready by the next meeting. In the mean time, those members who chose to send to Mr. Wharton Simpson a stamped and addressed envelope might receive copies without delay.

Mr. REJLANDER's paper, "An Apology for Art Photography" (see p. 88), was then read by Mr. Wharton Simpson, Mr. Rejlander himself suffering from some indisposition. At the conclusion of the paper, Mr. Rejlander handed round for inspection a couple of pictures, consisting of donkeys' heads, drawn by light on sensitive paper without the aid of negative or camera; the pencil of the sunbeam simply being wielded by Mr. Rejlander's hand. He also exhibited a sketch showing the plan of his studio, in which a much smaller amount of glass than usual is employed, the especial object being to produce studies for painters; the mode of lighting is intended to produce similar results to those obtained in the studio of the painter. A group designed for a composition picture, as referred to in the paper, was examined with much interest.

Mr. WALL, in continuation of the discussion, read a paper entitled "Thomas Sutton, B.A., on Art Photography" (see p. 89).

Mr. REJLANDER then laid before the members a choice selection of photographic studies from his portfolio. Some of these were selected with a view to illustrate the plasticity of photography in producing effects, and faithfully imitating in life, studies in the style or manner of various great masters, amongst whom were Raphael, Velasquez, Titian, Teniers, and others. In some the test of photography had been applied to the drawings of Raphael, in which the figures were in peculiar action, or unusually lighted; and, as Mr. Rejlander observed, it was as pleasant to observe that the test of photography proved the truth of drawing in the muscular action and anatomy of Raphael's figures, as it was to know that effects so similar to those of the great master could be produced by photography. Others illustrated how, by the posing and action only, a sentiment could be expressed or a story told. This was shown by a charming pair of studies entitled "Cupid in Trouble and Cupid in Despair," the action in the latter, in which the baby model leans forward grasping his leg, being wonderfully expressive.

Another picture illustrated a similar idea, showing how a story could be told, and expression thrown into a picture produced by the aid of lay figures only. It was an allegorical picture, the title of which we forget, but which might have been called a "Dream of Life." A male figure is laid sleeping, and his dream is indicated by the aid of a mysterious-looking article, in shape like a hollow truncated cone, consisting of a series of rings, or hoops, known, we believe, by the initiated, as a "crinoline." On these hoops, as on the bars of a ladder, the small lay figures were climbing, the different action and positions aptly displaying character and intention. Some were resting happy and content on the lower round of the ladder, whilst others toiled eagerly forward far above them; some had dashed forward with such precipitancy that, having nearly attained the summit, they then missed their footing and were tumbling headlong, whilst others—very few—having reached the topmost round, look calmly or proudly down on the toilers below.

A charming study of a child, smiling and interested, called by Mr. Rejlander, "Do it again," gave occasion for an anecdote of the mode in which the expression was obtained. The ordinary bribes of childhood had been insufficient to interest the little urchin, and a female attendant had, therefore, attempted the extraordinary feat of eating a nail, which was in the wall opposite to the child, who was mightily tickled, and exclaimed,

"Do it again," and whilst waiting, watching with amused interest for the feat to be done again, the portrait was secured.

Many other studies of expression were exhibited, with anecdotes of the mode in which they were secured. Studies of muscular action, of graceful action, of the nude, of drapery, &c., were also exhibited and explained during a desultory conversational discussion, in the course of which a gentleman present remarked, in confirmation of some remarks on the aid to the artist furnished by photography, that Burford's "Panorama of Rome" was painted by Mr. Selous from photographs of that city.

After a few remarks by the Chairman, a vote of thanks to Mr. Rejlander was moved by Mr. Simpson and seconded by Mr. Wall, who wished Mr. Rejlander's detractors had been present, as he thought the studies they had examined, and the comments and explanations they had heard, would have been sufficient to convince the most stubborn of the art claims of photography. The vote of thanks having been passed by acclamation,

Mr. REJLANDER, in acknowledging the vote, said, that in his endeavours to make photography an aid to the painter, he had almost been as modest as the most fastidious person could wish. Where he had in the service of art delineated by photography the nude figure, he had scrupulously avoided the violation of modesty, both in act and thought. He disliked immodesty, and in his pictures had always avoided it; and he was sure if those who had spoken of the indelicacy of his pictures knew the injustice they had done him, they would be sorry for it. However, when his pictures were condemned, he did not care about fighting, and instead of producing other composition pictures for which he might have to fight, he confined himself to studies for artists, which were often required most by those artists who most decried photographic aid. He had many conceptions, and should have liked to have produced many pictures but for this repression. In reference to the art claims of photography, it was undoubtedly a mechanical and chemical art, but it was capable of being applied as a fine art, and he hoped for the time when there would be a class for photography in the Royal Academy, under the guidance of approved artists. By this means, artists and photographers would get better to understand each other, and the capabilities and limits of their respective methods. Once more he thanked them, and if health permitted he hoped again perhaps to do something in composition photography. But he would bide his time.

Some prints were presented to the Society by Mr. Sidney Smith, and Mr. Price's paper "On the Theoretical Principles of Positive Printing" was deferred until the next meeting. The proceedings then terminated.

Correspondence.

FOREIGN SCIENCE.

[FROM OUR SPECIAL CORRESPONDENT.]

Paris, 11th Feb. 1863.

A new method of microphotography is proposed by M. H. Vogel, which is so simple, that any one, however little acquainted with operations of this nature, may easily avail himself of it. To a microscope, placed horizontally, a small photographic camera is adapted, fitted with a single achromatic landscape lens, of about 4" focal distance, and arranged in such manner that the optical axes of the two instruments coincide, and that the objective of the camera almost touches the eye-piece of the microscope. M. Vogel has also attempted to photograph telescopic images, but the undertaking was much more difficult, and the results hitherto obtained are not satisfactory.

MM. Bunsen and H. Roscoe have published, in *Poggendorff's Annals*, a very important article on the chemical action of light applied to the phenomena of the organic and mineral kingdoms. The learned authors propose to themselves to examine the modifications and the chemical effects which the surface of the earth is susceptible of receiving, either from the direct rays of the sun or from diffused light. These researches, extremely delicate, require new means of experimenting, into the details of which it is not possible to enter in this place. It must suffice to notice,

among the results obtained, that the chemical action of light, *photochemistry*, varies according to the geological constitution and the agricultural condition of the soil, the annual and diurnal obliquity of the rays, the hours of the day, the latitude and the seasons. The *maxima* of effects are remarked at the period of the solstices. In order to classify the phenomena, the points of equality might be united by lines, as is done with the distribution of heat on the terrestrial surface. We should thus obtain a set of *isophotochemical lines*, diurnal, monthly, and annual, and of unquestionable utility for the progress of general physics and meteorology, which are still in their infancy. But to realise this magnificent and difficult programme requires the union and co-operation of all the observers living in every quarter of the globe. A consummation which, unfortunately, is very unlikely to be attained.

M. A. d'Abbadie has presented a report to the Geographical Society, on *The Photographic Plane-Table*, invented by M. Auguste Chevallier,* in which he pays a warm tribute of admiration to the efforts of the persevering inventor in perfecting his apparatus. Geographic photography is placed between two extremes, one of which is the microscope, the other the telescope—the infinitely small and the infinitely great. It aims at employing the flat pictures, upon which are fixed the panoramic landscapes and varied plans, which the traveller perceives unfolded to his view in all their new and changeful details. But how shall we deduce the precise data of latitude, longitude, and altitude, that hidden but substantial framework which sustains the varied structure of a map? This problem has been ingeniously solved by M. Chevallier, who, disdaining the more enticing phases of the photographic art, has put aside the picturesque, and in his landscapes disregards only the relations essential to geography; or the forms and positions relative to the signals. To this end he has converted the photographic negative into a plane-table, and by a mechanical, and we may also add, automatic process, retained all the advantages of this elementary instrument, but which is, in the last analysis, the capital instrument of topography.

In using the ordinary plane-table we must carefully trace the lines which note the direction of each interesting signal, such as the angles of houses or fields, mouths of rivers, summits of mountains, &c.; we must afterwards write the name of each object projected, or, if ignorant of it, as is frequently the case in travelling, it is indispensable that an exact sketch of each signal noted be made, in order to recognise it at the new station to which the traveller repairs to set up again his plane-table. We may have already anticipated that photography employed in such a case will cause the sketching to be dispensed with, and provide a guarantee against the errors which may, in the sketches, seriously affect the accuracy of the essential details. Moreover these sketches demand much time; and experience has often proved to us that after having fixed upon a distant signal, atmospheric changes will veil it from the sight before there has been sufficient time to sketch its form. And this is not all: the ordinary plane-table does not admit of the projection of many objects very near together without introducing confusion into the work. Besides, it gives only the relative azimuths. It has therefore been found desirable to add to it a lens and a circle, or at least a graduated arc, to obtain the angle of height, or apozenith, an element indispensable for knowing the altitude of the signal. But then the instrument, although complete, becomes very complicated, like that invented by M. Porro, and most practical geographers prefer to replace the plane-table by a more precise instrument, which gives both the vertical and horizontal angles at the same time. The elements thus obtained, first transcribed in a register, must be repeated upon another sheet of paper by means of a transfer. And, after all, this method of observation does

not dispense with the minutious care of sketching each signal. And it is difficult for the energy of the topographic traveller to overcome all these obstacles. By the aid of photography he can accomplish in a quarter of an hour a more satisfactory result than in six hours without it.

It is easy enough to obtain a panorama of the horizon by means of photography, but it was a difficult task to give to the photographic plate all the advantages of an ordinary plane-table. M. Chevallier has solved this difficult and important problem. Other operators had shown, as he has done, that an objective, furnished with a rotary movement, can reproduce a panorama, without confounding the images in it by superposition; but what appears to specially constitute his discovery, is, that of being able to operate usefully upon a plane surface, by fixing his glass plate, coated with a sensitive film, upon a moving vertical wheel articulated at right angles, with a fixed horizontal wheel, the teeth of which force the vertical wheel to terminate a complete revolution upon itself at the precise moment when its horizontal axis has finished its tour of the horizon. The principle of this invention consists in the transformation of the horizontal movement of the camera into an equal but vertical movement of the glass plate, which registers the picture in a continuous manner. Beyond the well-known manipulation of photography, the employment of this instrument requires no other preliminary than the regulation of the level which the positive requires.

THE DISCUSSION ON ART PHOTOGRAPHY.

SIR,—I quite intended to have been present at the last meeting of the South London Society to take part in the discussion on the papers by Messrs. Wall and Rejlander, but the weather was so provokingly brilliant here last week that I was compelled to remain at home to take advantage of it. However, the papers read by those gentlemen so completely upset all that Mr. Sutton advanced against art-photography in his paper read before the Photographic Society of Scotland, that it would have been scarcely necessary for me to have said one word on the subject. Having been coupled by Mr. Sutton with Mr. Rejlander, as an offender against photographic propriety in the pictures I have produced, I have to thank the latter gentleman, and also Mr. Wall, for the very valuable and convincing arguments they employed in our defence, although I think the matter was not worth the trouble they took about it, for I am sure that if Mr. Sutton were left to himself for a little time, he would, with his usual heedlessness of consistency, turn round in favour of all he now opposes. The efforts of those who endeavoured to raise the character of our art having the approbation of every other journal devoted to photography, it cannot be of the slightest importance to them what are the present opinions of an editor who capriciously praises and condemns by turns.

HENRY P. ROBINSON.

Leamington, Feb. 16, 1863.

NO OUTLINE IN ART.—Mr. Ruskin, in speaking of his mode of teaching drawing at the Working Men's College, says, "There are no *outlines* in nature, and no pupil in my class is ever allowed to draw an outline"—arguing, it would appear, that as there is "no outline in nature," there should be no outline in art. Nature, he says, relieves one mass or one tint against another, but there is no outline. In theory, this is to a great extent true; but yet it is very convenient to the artist, in making a composition, to define by an *outline* how far and in what form a mass or a tint extends itself; and the effects produced by these artistic lines of demarcation are so agreeable to the eye in themselves, if done in a true artistic spirit, that many pleasing decorations may be made with outline alone. The outline sketches of some artists are indeed more sought for by the true connoisseur than the finished work in which they have been blended into the masses. Nevertheless, Mr. Ruskin's acutely perceived and ingeniously defended crotchets, though often untenable, are always full of suggestive hints of the highest artistic value.

* Vide PHOTOGRAPHIC NEWS, vol. vi. pp. 63, 77.

Talk in the Studio.

THE REV. T. F. HARDWICH.—Many of our readers will learn with pleasure of the publication of a portrait of Mr. Hardwich, who, although retired from the photographic world, is still kindly remembered by photographers. Mr. St. George has recently issued a card picture, which is a characteristic portrait and a brilliant photograph. We have pleasure in commending it to our readers, and we may also call attention to it as a specimen of fine printing.

ROBBERY OF LENSES AT THE CRYSTAL PALACE.—George Restall surrendered at the Surrey Sessions to take his trial upon an indictment charging him with stealing eighteen lenses, the property of his employers, Messrs. Negretti and Zambra, opticians, at the Crystal Palace. Mr. Robinson, with Mr. Oppenheim, for the prosecution; and Mr. Sleight, specially retained, with Mr. Thompson, conducted the defence. The evidence for the prosecution having closed, Mr. Sleight addressed the jury for the defence; when the Chairman summed up, and the jury, after an absence of nearly an hour, returned a verdict of guilty against the prisoner, with a strong recommendation to mercy on account of his previous good character. Sentence was postponed.

MOIST SENSITIVE PHOTOGRAPHIC PLATES.—A correspondent of the *Scientific American* says:—It has long been an object with photographers to keep prepared sensitive plates moist longer than ordinary, as it is well known that in a dry atmosphere, in doors or out, a sensitive plate will crystallize in a few minutes and be rendered unfit for use. My remedy is this:—Take newly-made plate frames and varnish them with gum shellac dissolved in alcohol, until the wood is thoroughly saturated; after being dried, immerse them in water for an hour, take them out, drain and wrap them in a wet towel, and place them in a box made of wood or leather, with a close lid. The towel should be wet daily, and the frames kept in the box. By these means, with a nitrate bath of thirty to thirty-five grains, I have no difficulty in keeping the plates two or three hours or more. I have had many inquiries about my process upon the supposition that there was some secret in the preparation of the plate; but it consists in preventing the evaporation of the moisture, and that is effectually done by the above method.

PHOTOGRAPHY AT THE SEAT OF WAR.—"Decidedly" says the *Corinth Tribune*, "one of the institutions of our army is the travelling portrait gallery. A camp is hardly pitched before one of the omnipresent artists in collodion and amber-varnish drives up his two-horse wagon, pitches his canvas gallery, and unpacks his chemicals. Our army here (Fredericksburg) is now so large that quite a company of these gentlemen have gathered about us. The amount of business they find is remarkable. Their tents are thronged from morning to night, and "while the day lasteth" their golden harvest runs on. Here, for instance, near General Burnside's headquarters, are the combined establishments of two brothers from Pennsylvania, who rejoice in the wonderful name Bergstresser. They have followed the army for more than a year, and taken, the Lord only knows, how many thousand portraits. In one day since they came here they took in one of the galleries, so I am told, 160 odd pictures at one dollar (on which the net profit is probably ninety-five cents each). If anybody knows an easier and better way of making money than that, the public would know it.

To Correspondents.

B.—There are several modes of producing enamel photographs on china, some of which are secrets and others patents. The process of M. Joubert has repeatedly been described in our columns, and is patented. It consists in coating the china or glass with a mixture of honey, albumen, and a bichromate, exposing under a transparent positive, coating with an enamel powder, and burning in the image. The process of M. Camarac has not been stated in detail so far as we know: we believe it consists in producing a transparent positive on a collodion film, either direct upon the china, or by transfer from a glass plate; toning this with gold, and then burning-in. We do not think the latter is patented in this country.

A. R. P.—Two ounces of hyposulphite of soda ought to be sufficient to tone two batches of 40 card portraits, provided they are well washed and the hypo is kept neutral. 2. Grey tones, if you desire them, may be produced by the aid of almost any of the toning formulas, by making them strong enough and toning long enough. With some samples of highly albumenized paper, however, it is very difficult to get beyond tints of purple brown. 3. There may be a limit to the time an exciting bath ought to be used even if the strength were kept up, as it is constantly receiving some

foreign matter from the albumen, and some aggregation of nitrates; but we have not noticed any deterioration, when the strength was maintained, in our own case.

J. K.—The price of Colonel James's work on photozincography is 12s. 6d.; it is necessarily a somewhat high-priced work, having several photolithographic illustrations.

T. W. S., Cambridge.—Any good bromo-iodized collodion will answer for the honey and tannin process; but we cannot with certainty recommend any commercial sample. It should not contain less than one grain of bromide to the ounce, and might, without disadvantage, contain more.

Y. Z.—The lens you name may be used for an enlargement of about four or five diameters, with a moderate stop, without impropriety; but the No. 1 triple lens is best for the purpose. Report on your glass in our next.

L. SHAW.—Your prints are promising. Many of your difficulties will disappear with practice. The spot on the shoulder appears to have arisen from an air-bubble or other similar cause having prevented the perfect action of the toning bath at that spot, and thus left it browner than the remainder. The toning bath with gold and acetate of soda is a very good one. If you have any special difficulties please state them specifically.

CALICO.—The formula of Messrs. Fordos and Gelis appears very satisfactory. Chloride of calcium is altogether a different salt to chloride, or hypochlorite, of lime, and must not be substituted for the other. 2. The exact action of acetate of soda in a toning bath is somewhat uncertain, and the formula not less so; the chief thing that is known on the subject is, that, practically, it gives good results. Samples of chloride vary in acidity, and samples of acetate of soda, which should be neutral, are some faintly acid and some slightly alkaline; generally, however, the latter. Wherever we have any reason to fear a trace of acidity in the toning bath we place the prints in a weak solution of carbonate of soda before fixing. This is a very safe practice, and permits the use of the gold bath if even faintly acid. A bath of gold, quite neutralized with carbonate of soda, will tone very well without any other addition. 3. We will try the intensifying process with a bromide. We cannot give any opinion *a priori* as to whether the results will be more stable than those of the iodide.

GILCHRIST.—The best enlarging lens is the triple; but a good portrait lens, say a quarter-plate, may be used for the amount of enlarging you propose.

CUDDE LUGES.—You have quite misunderstood us. There have been copyright acts in force for the protection of engravings ever since 1735. We believe the term of protection is twenty-eight years, and, therefore, all engravings published within that period, which have complied with the provisions of the law, are copyright, and may not be copied. 2. In filling up the office form for registering photographs you may place more than one picture in the form, but you must pay the fee upon each picture. 3. We have not seen any of the prints to which you refer, and cannot offer an opinion thereon.

EXCELSIOR.—Your glass is too brown, not the true silver-flashed tint. It lets some active rays through, but very few, and could be used with safety except in a very bright light. We may here give a word of advice to those of our readers who may require to send us samples of glass for examination. It will save some disappointment and trouble, if, in obtaining a sample of glass from a dealer, it be ascertained at the same time that he has a sufficient stock of the same sample on hand. Many dealers think they are quite near enough if they supply something which they conceive to be similar in tint, but which really may be altogether different in its power of repelling chemical rays. It is also important to secure, if possible, the silver-flashed glass, which generally has a somewhat mottled effect, as though it were stippled rather than stained.

AMATEUR DRY PLATE.—Almost all photographic materials, which come under the general head of "Chemicals," keep, if properly stored. Nitrate of silver, hyposulphite of soda, acetic acid, pyrogallic acid, gallic acid, chloride of gold, acetate of soda, &c., if kept dry and air-tight, keeps almost indefinitely. Plain collodion, cadmium-iodized collodion, and good bromo-iodized collodion will keep a long time—at least a year, if kept with any care; as will also iodized paper. Albumenized paper is best used as fresh as convenient, and will injure in a few months, if at all damp. Sensitive plates, or paper, should be kept dry and air-tight, but in most cases there is a tendency to deteriorate. 2. Mr. Bartholomew has given tolerably full details of his morphine process in our pages; but he will, doubtless, have pleasure in supplying more details on the points you wish, namely, the length of exposure, as compared with wet plates; whether an iron developer be necessary; whether acetate of morphine may be used in place of nitrate, and the proportion; whether any preliminary coating be necessary, and what is the best. 3. We cannot tell you much of the probable value of negatives of foreign landscapes. You will best ascertain by writing to some of the photographic publishers in this country.

CHARLES DERBY.—We have delayed publishing your description of a photometer, until we had more time to examine it carefully, as it does not appear very explicit. We certainly should not recommend you to patent it. We never undertake the duty of attending to patents, and did not understand you as making any inquiry about the subject.

J. B., Scarborough.—If you take the portrait of any person on your own account, with a view to publication, no agreement is required to permit you to secure the copyright. You execute the work for yourself, and it is yours. But if you take the portrait for the sitter himself, or for some one else, it being, as the Act phrases it, "a commission," then an agreement in writing is necessary. If the commission were for the sitter himself, and he be dead, then the agreement must be with his heir, who is his legal representative, can give you the proper permission in writing. We do not charge any fee for advice; but the claims upon our time prevent us writing private letters on subjects which can be answered in this column, where the information can also be of use to others.

T. R.—We do not know of any certain method in which old manuscripts can be copied by simple pressure.

Several Correspondents in our next.

Photographs Registered during the Past Week.

MR. T. SMITH, Cemetery Road, Sheffield,
View of St. John's Church, Masboro', Rotherham.

MR. THOMAS WORDEN, Newcastle-on-Tyne,
Two Photographs of Scenes in Newcastle-on-Tyne.

MESSRS. PETSCHLER AND CO., Manchester,
Two Portraits of Mr. Wright, the prison philanthropist.

MR. ALFRED THROGDON'S HEATH, 36, Camden Street North, N.W.,
Portrait of James B. Bunning, Esq.

THE PHOTOGRAPHIC NEWS.

VOL. VII. No. 231. — February 27, 1863.

CONTENTS.

	PAGE
Photographic Soirees	97
On a Process for Direct Intensifying	97
Photographic Exhibition.—Fifth Notice	98
Critical Notices	99
Collodion Wet and Dry. By M. L'Abbé Despratz	100
Glasgow Photographic Association.—Soirée, Exhibition, and Conversazione	101
The Application of Photography to the Magic Lantern Educa- tionally Considered. By Samuel Hignley, F.G.S., F.C.S. ...	104

	PAGE
New Process for Positive Printing. By M. Bertrand	101
Proceedings of Societies	105
The International Exhibition.—Report of the Jury	105
Photographic Notes and Queries	106
Miscellaneous	107
Talk in the Studio	108
To Correspondents	108
Photographs Registered during the Week	108

PHOTOGRAPHIC SOIREES.

A VERY successful soirée of the London Photographic Society was held on Friday evening last, at the Gallery of British Artists, in Suffolk Street, where the exhibition of photographs is now held. A brilliant company, including many persons of distinction, thronged the rooms, examining the excellent display of pictures until a late hour.

We call the especial attention of our readers to a copious report, on another page, of a very brilliant soirée, held by the Glasgow Photographic Association. Indefatigable efforts had been made to secure a first-rate collection of photographs for exhibition; very able and interesting speeches were delivered, various photographic illustrations and experiments made, amongst which the erowing one was the production, by the aid of the electric light, of a portrait negative; Mr. Jabez Hughes, whose name is well known to our readers, being the sitter.

From this a transparency was immediately produced, and, in the course of a few minutes, the portrait was perfected on to the screen of the magic lantern, and shown, amid much enthusiasm, to the entire audience. We commend the account of this soirée to photographers, because it exhibits an amount of energy, unity, and enthusiasm among photographers, rarely witnessed, but worthy of all emulation.

ON A PROCESS FOR DIRECT INTENSIFYING.

M. BLANQUART EVRARD has addressed the following communication to the Paris Photographic Society and recorded in the *Bulletin*.

It has for a long time been known that when a sensitized surface is exposed to light, after it has been impregnated with a reducing salt in solution, we obtain, upon removal from the camera, a completely developed image.

In ordinary practice, in which the sensitized film only is exposed in the camera, the image obtained by the exposure remains latent until revealed by a reducing solution.

Three agents, therefore, concur to produce the image.

1. A sensitized film (sensitized collodion.)
2. Light.
3. A developing salt. (Sulphate of iron, gallic and pyrogallac acid.)

I shall not occupy myself in this place either with the sensitive film or with the reducing salts whose action varies; the sulphate of iron precipitates the silver in the metallic state; the gallic and pyrogallac acids form with silver, in my opinion, gallates of silver more or less coloured;—but I shall examine the action of light, from which it seems to me possible to derive a new resource under certain circumstances.

It is admitted that there is a complete formation of the image by the exposure to light, however short may have been its duration. We may then infer that if the image does not entirely appear under the action of the reducing

salt, it is because the latter is not sufficiently subtle. It remains, then, to find a reducing salt capable of revealing the image in all its strength.

But has the sensitive film itself been so deeply impressed as to be able to transmit afterwards the image in its entirety?

From what occurs in ordinary practice, we may be allowed to doubt if it does.

When the exposure has been too short, the image is formed only on the surface of the film. It results from this, that the layer of reduced silver has not sufficient thickness to oppose a sufficient obstacle to the passage of light. In taking the positive, we obtain only a pale and ineffective design. If, on the contrary, the exposure has been too long, the reverse action is produced, the parts most lighted assume too great an importance. The details in the lights disappear, in compensation we obtain details in the shadows which a short exposure would not have given, but the picture is none the less poor and inharmonious. The negative is lost.

The point at which we must stop the exposure is then very difficult to seize upon. There is an equilibrium to be preserved, which becomes impossible under certain conditions of lighting and colour.

We employ, it is true, different means to give either more importance to certain parts of a negative, or to diminish the value of certain others, but these partial intensifyings, by means which I am almost tempted to call mechanical, are almost always defective.

Thus far, then, we have actually acquired the possibility of intensifying a negative as a whole, and still the means employed are hazardous, and very often compromise its existence by causing a softening of the collodion, wrinkles, rents, &c. Besides, it seldom happens that a successful intensifying does not cause the image to lose a portion of its primitive delicacy.

For the chemical means hitherto employed we must substitute a more inoffensive method, so as to develop any portion of the image at pleasure, by localizing the operation, either by too short an exposure, or that the colouring of certain objects adverse to the photogenic action be suitably modified.

This method will be *the continuation, under certain conditions, of the action of light upon the sensitive film*, or, in other terms, *the light completes the manifestation of the image formed in the camera*. I sum up the principles upon which my theory is based.

On removal from the camera, the image in its entirety is imprinted on the sensitive film. The impression is more or less decided, according to the duration of the exposure or the intensity of the light.

The image is visible only after being developed by the reducing agent, and it is not till then that we can judge its value.

However, if before developing the image we assume that the exposure has been insufficient, and that we desire to augment it, we have only to remove the cap from before the

objective, the impression continues, nothing being changed in the chemical condition of the sensitive film.

Query: would it be the same if we re-exposed the image after it has been precipitated by the reducing agent?

A priori, we reply, No! Nevertheless experience has shown me that if, upon removal from the camera, we develop the image by the gallic acids or sulphate of iron, and that after having washed the negative simply in water, we expose it to the light, the image strengthens more and more, it may even attain to an astonishing vigour.

To account for this phenomenon, and explain why the image does not become a black mass, as happens when we treat a paper negative in the same manner, we must consider that in a collodion glass plate the surface only is impregnated, and that the reducing salt which precipitates the image removes at the same time all the silver which has not been impressed, and is carried away with it by the washing in water. There remains, then, on the negative no other silver upon which the light can act beside that which forms the image.

We can readily understand that it is different with a paper negative. The washing in water clears only the surface. The interior of the paper retains a quantity of silver which is impressionable by light so long as it is not dissolved in the hyposulphite.

How does light continue the development of the image? Does the metal pass to a higher state of oxidation? Is a thicker film precipitated? It is certain that the opacity of the image sensibly increases. Positives obtained in the first and second states of the negatives exhibit very striking differences.

The atmosphere plays an important part in the action produced. If we preserve a portion of the image from contact with the air, and cover it with a transparent varnish which permits the light to pass, the part covered with varnish becomes only feebly coloured, while the remainder sensibly deepens in tone, we must, therefore, admit that there is a greater oxidation of the metal.

As to the precipitation of a thicker metallic film—for this to take place it is necessary that the first exposure in the camera has impressed more of the sensitive salt than the reducing salt can precipitate; there will then be an incomplete reduction of a portion of the silver, a reduction sufficient to prevent its being carried off by the water in washing, but susceptible of being continued and completed by a second exposure. I admit this more readily from what takes place when, if after washing, the negative be fixed by hyposulphite of soda, and afterwards exposed to the light, we no longer obtain an intensifying of the image, the hyposulphite having dissolved all the iodide of silver not completely impressed by the light.

Whatever the theory I humbly submit to the appreciation of the eminent chemists to whom you refer questions of this sort, it has always appeared to me

That it is possible to strengthen a collodion negative, by exposure to light alone, after simply washing in water, on removal from the developing bath.

That we can follow with the eye the progress of the operation, and stop it at will by irrevocably fixing the image with hyposulphite of soda.

That we can also localize the action of light by exposing to its contact only a portion of the image, and thus obtain a partial intensifying.

To arrive at this interesting result, we must, by means of screens suitably placed, so as not to form gaps in the image, merely obscure those parts of the object which may be considered as being fully impressed. In this manner we can strengthen at will any portion of an image just as the engraver in mezzotinto lights his plate by means of a burnisher.

Note.—If, to carry the comparison with the work of the engraver still further, we wish to obtain the reverse effect, that is to say, darken the parts which are too light, and give more depth to the shadows of a negative, we must

diminish the opacity, or thickness, of the film of reduced silver. We arrive at this result by submitting these portions to the action of the vapour of iodine. These vapours combine with the silver forming, at the expense of its thickness, an iodide of silver, which dissolves in hyposulphite of soda.

PHOTOGRAPHIC EXHIBITION.

FIFTH NOTICE.

As the last week of the exhibition approaches, and it is now open in the evenings, as well as during the day, we hope those of our readers, who can, will make the most of the remaining opportunities of examining the contributions.

We have not hitherto given much attention to the portraits exhibited, chiefly because a very large number of them had been already exhibited in the International Exhibition. We will now, however, briefly glance at such pictures as have chiefly attracted our attention. The two portraits, which have, perhaps, excited more interest than any others in the exhibition, are those of Alfred Tennyson and Thomas Carlyle, both by W. Jeffreys. These, apart from the distinguished character of the men, although only half-plate pictures, are as admirable specimens of portraiture as any in the exhibition. Characteristic in pose, round, soft, and full of half-tone, yet very vigorous and forcible; they are altogether exceedingly fine photographs. The grim power of the Chelsea philosopher, and the lofty thought of the laureate, are well rendered in the pictures, and convey the impression at once that the portraits are characteristic of the men.

Mr. Claudet's portraits, to which the medal was awarded, are very numerous, and are scattered throughout the different rooms of the exhibition; they consist of *cartes de visite*, of various large-sized pictures, taken direct, and of solar camera pictures, plain and coloured. They all display many excellent qualities. Those we like best are the large pictures, taken direct from life, of which, No. 116, a portrait of a lady, in a light dress, is a fine example. Some of the enlarged pictures are also very fine.

The solar camera pictures, of Mr. Stuart, we have before fully described. We need only remark here that, being hung amongst several brilliantly-coloured pictures, they are seen to less advantage than when examined alone, as they lose brilliancy by contrast with the amount of colour surrounding them.

An untouched solar camera picture of Herr Formes (563) exhibited by Mr. McAndrew, looks grey, flat, and poor. It is unfortunate that solar camera pictures so often run to extremes. If they are soft they are flat and feeble; if vigorous, they are coarse and hard. Mr. McAndrew's other contributions are for the most part very excellent, and comprise some excellent specimens of large untouched portraiture.

Mr. T. R. Williams sends a fine selection of his charming vignettes of rare beauty and delicacy, both whole plates and card pictures, of which, however, we prefer the larger size. Mr. Mayland, of Cambridge, sends a frame of albumen portraits (655), so nearly resembling those of Mr. Williams in style, and nearly equalling them in quality, that we have heard them frequently mistaken for those of the latter gentleman. This we consider almost the highest praise they could receive. Mr. Mayland's card pictures (654) are equal to any in the exhibition.

Mr. Robinson sends a small frame of his exquisite card portraits (653), which are unfortunately hung too high for careful examination. Two or three of the groups in this frame we consider the finest card pictures ever issued. A standing group of two pretty girls at the entrance of an arbour is especially worthy of notice.

A frame of 10 by 8 pictures (589) exhibited by Mr. Carrick, presents some lamentable instances of what to avoid in careful examination, and fills us with regret. Mr. Carrick is a miniature painter of no mean standing; and in many respects the portraiture and photography both are good; but

the backgrounds are so "loud" that it is next to impossible to see the portraits; the objects in the painted background will obtrude themselves, and the whole effect is one of extreme confusion. To use the remark of a foreign gentleman who examined them, they looked "very much troubled." There is one exception to the remark amongst Mr. Carrick's pictures. In this (690), a lady is standing in a room, her face apparently lighted from an open door, and in this case the effect of the flood of light on the objects in the interior is very pleasing.

Mr. Joubert exhibits some very fine cards. Mr. Mullins, of Jersey sends some very charming card pictures of the same class, and Mr. Brooks, of Newberry, sends a frame of cards which are interesting as specimens of double printing.

Mr. Cooper contributes a good selection of examples of resin printing, many of which are also very charming photographs. Artistic in feeling, soft, and delicate, as well as brilliant, they are admirably fitted to recommend the use of resinized paper for very many purposes. In these, as also in the exquisite specimens of Mr. Cooper on silk, the system of double or fancy printing, is applied with excellent taste.

Hennah and Kent send some very fine portraits, which, if they do not maintain the pre-eminence in portraiture they once possessed, yield that position, not from any lack of excellence of their own, but from the gradual progress of others up to a similar standard.

Some exceedingly perfect specimens of portraiture, by Angerer, of Vienna, are not numbered, but they should not be overlooked by visitors interested in this branch of the art. There are four other unnumbered portraits to which we would call especial attention: they are hung in the door-way leading into the room containing French contributions. These are by Dr. Diamond, and will interest photographers not only as far surpassing any other specimens of amateur portraiture, but as equalling the best to be found in this exhibition, both as artistic and characteristic portraits, and as perfect photographs.

Associated closely with portraiture are life-studies, of which, whilst there are not very many in this exhibition, there are a few gems. We have before referred to the studies of Viscountess Hawarden, and which, very properly, we think, gained the medal as the best amateur contribution. There is a wonderful charm of freshness about these pictures which is much less common in photographs than we like to confess. These consist for the most part of female figures with interior accessories: there is much grace and beauty both in the fair models themselves, and in the posing and general arrangement, but the chief charm consists in the daring lighting and the artistic effects of light and shade secured. There are figures brought close to the window of a room into which pours broad sunlight: the portions tipped with the bright light are full of detail and free from chalkiness, and the masses in deep shadow are perfectly transparent and free from blackness. In some cases a portion of the window, balcony, and objects beyond is included, and these have sufficient detail to be compatible with atmosphere and distance. In some cases the effect of light reminds of some of Rembrandt's pictures, in which one bright light is in strong contrast with a mass of shadow into which, however, the light is sufficiently carried to secure both transparency and breadth. We regard these pictures as most instructive and well worthy of study as illustrations of lighting of the effects possible in photography. They are produced we understand with a highly bromized collodion: a very strong iron developer, sometimes containing as much as fifty grains of iron to the ounce, and with Dallmeyer's No. 1 Triple lens, which secures this wondrous depth of definition. Should these studies be published, and we believe we may venture to hope they will be, Lady Hawarden, having, we believe, given her consent, we should recommend every portrait photographer to possess and study them.

Mr. Rejlander has not contributed many of his fine art photographs to this exhibition; we find however, two very

charming studies, Nos. 567 and 574. The first is one of those genuine touches of humour in which Mr. Rejlander is so happy, and is entitled, "Give us a copper, yer honour." A comical, ragged urchin with broom in one hand, and the other touching his cap, is trotting along evidently in front of some one, to whom he turns his head and looks up; his face wears a droll, coaxing expression, as he begs the copper he has earned by sweeping the crossing. The second picture is a beautiful head surrounded with white drapery, arranged somewhat after the fashion of a nun; the general effect being after the Madonna of Sassoferata. The expression and general treatment are very beautiful, the whole of the face being in a mezzo-tint, with an exquisitely transparent and delicate shadow on the forehead, cast by the projecting drapery. Altogether it is one of those rare gems seldom obtained by photography.

Besides these and some before noticed, there are not many figure studies. There is a picture by J. J. Keet, entitled, "The Lost Game," which does not convey any especial idea beyond two persons playing a game of chess; and a couple by J. T. Lucas; one, "Hard Times," the interior of a Lancashire cottage with its inmates; and another, "The Maid of Llangollen." The first of these is best, and has many fine points; the second is hard as a photograph, and a little wanting in reason for its title.

The coloured portraiture strikes us as a mistake; very much of it here is staring, vulgar, and coarse, with little of photography, and nothing of art. Some garish looking solar camera pictures coloured in pastels, are particularly offensive, in their hard, crude, raw colour, glaring without brilliancy, and suggesting nothing but chalk. The great evil of these things is, that while nothing of photography remains, being overlaid by the stiff drawing of the painter, the glaring colour spoils the eye for the quiet monochrome of the pure photographs which are near them. The best pictures here are those coloured in oil, of which some are exhibited by M. Claudet, which are really well coloured. Some portraits painted by M. De La Folie, and exhibited by Mr. Mc Andrew, possess great truth and purity of colour, with much force and brilliancy. No. 508 is a good example; No. 510, a portrait of a lady, is well coloured, but badly posed. Nos. 519, 539, 543, and 551, coloured by this gentleman, are all exceedingly good, the flesh being healthy and pure. The life size portrait of Mr. Chance of Birmingham, exhibited by M. Claudet, and that of Lord Brougham, exhibited by Mr. Mayall, are both fine. Mr. Brothers exhibits some fine composition groups, and one of the chief savans at the Manchester meeting of the British Association is well coloured in oil. Mr. Wall exhibits a large head coloured in oil, which has many good points, but he can paint better than this. There are many more coloured pictures, some of which are not worthy of notice, some moderately good, and many in regard to which silence is the best praise which can be awarded them.

Critical Notices.

PRACTICAL PHOTOGRAPHY ON GLASS AND PAPER. Fifth Edition. London: Bland and Co., Fleet Street.

THE especial claim to notice of a fifth edition of this little work is the fact that it is entirely re-written, and becomes practically a new book. Notwithstanding the fact that it has obtained a very wide circulation in its original form, not less than twenty thousand copies, we are informed, having been issued, the publisher recognizing the vast advancement made during late years, has felt it important that a book, for beginners, should contain instructions for the best and most approved practice of the art, so far as it is known at the present time, instead of the teachings written eight years ago, many of which must now be obsolete. The design of the work has also, it appears, become more comprehensive

a second part being produced, which is to deal with those branches of photography chiefly interesting to the advanced student, while the first part—that now before us—is chiefly elementary, and is confined to the wet collodion process, and to printing.

The style of the book is very simple and lucid: the student is not perplexed with discussions as to his various theories propounded; but is conducted by easy and sure steps into the practice of the art. An introductory chapter contains a brief statement of principles, and such an explanation of distinctive technicalities as may render clear and easy of comprehension the instructions which follow. They comprise the production of positives on glass, of collodion negatives, and of printing on plain and albumenized paper. There are also chapters on tinting positives on glass and paper; on the production of stereoscopic pictures; on imperfections and failures; and also one which will render the work valuable for calculation in many of the colonies, on photography in the tropics.

So far as we have examined the work, the instructions are always sound, as well as lucid and clear; and such as, if followed, will ensure successful results. A number of excellent wood engravings, illustrating modes of manipulation, as well as forms of apparatus, materially add to the interest of the book, which, as a whole, we can cordially recommend as one of the most simple, clear, and trustworthy instruction books we have seen.

THE COMIC ADVENTURES OF A YOUNG MAN FROM THE COUNTRY. Photographed by Dages and Harman, from designs by Percy Cruikshank. London: Ward and Lock.

THE claim which this little work has to the especial attention of photographers consists in the fact that photography has here taken a place very commonly assigned to lithography, being applied to the reproduction of a series of original sketches. It is unnecessary for us to trace the career of the "young man from the country, who thought no one could get over him on his way to visit the International Exhibition, and who went back without seeing it," beyond remarking that the designs possess some humour, but are a little wanting in delicacy. The photography is, however, unexceptionable, the prints being scarcely distinguishable from Indian ink drawings. They are chiefly on plain paper, and are printed with a margin, so as to avoid the evil of the book bulging and gaping from the accumulated thickness of the mounted photographs—an evil sometimes very annoying in other cases where photographs have been used for book illustration.

COLLODION, WET AND DRY.

BY M. L'ABBE DESPRATZ.*

Various Reactions.—It now remains to add some practical developments of the ideas we have suggested in our preceding article upon the sulphate of iron developer. First remarking, however, that the various methods we have successively described, are principally applicable in making use of a sensitizing bath, which, if not new, had been but little used. For, with an old bath containing a considerable proportion of alcohol and ether removed from the collodion film, the development of the image is not always made with the wished-for regularity; and, in that case, the success which we announced as infallible becomes, in some measure, exceptional. Yet still, even with a very old silver bath, and containing a strong proportion of alcohol and ether, a perfect result may also be obtained by developing with sulphate of iron as concentrated as possible; only in this particular instance, which most frequently becomes general, we must have recourse to a special manipulation, which we now proceed to describe carefully.

First, a word upon the preparation of a good sulphate of iron bath. In a quart of rain or distilled water dissolve to

saturation, cold, some pure sulphate of iron. The solution will be saturated when some crystals remain undissolved. If the sulphate be really pure, the solution will be at once fit for use. If commercial sulphate of iron be used, which frequently contains free sulphuric acid, and very often some sulphate of deutoxide of copper, we must drop into the solution some Paris white, which will decompose this latter salt, and also neutralise the sulphuric acid in excess. It is then left four and twenty hours to settle. The bottle containing the solution should be kept always full, by the addition of a quantity of the mixture of sulphate and water equal to that used.

As we may perceive, this bath is very easily prepared; but we have never allowed ourselves to believe that it was necessary to complicate it by the addition of alcohol or any acid whatever, and still less to greatly reduce its strength. There may, it is true, be very plausible reasons given for having recourse to these additions; but we believe it is most advantageous to do without them altogether. What, for instance, are the reasons given for the addition to the sulphate of iron, of either alcohol, acetic acid, or even sulphuric acid? Doubtless they have been recommended with a view of putting the iron bath in harmony with the silver bath, if not in a chemical point of view, at least in a physical. For the sensitizing bath containing alcohol, ether, or even acetic acid, experiences a kind of repulsion for the bath of pure sulphate, with which it mixes only with difficulty. An acid added to the iron bath, and particularly alcohol, destroys this mutual repulsion and changes it into a real affinity: but this advantage can be obtained only at the expense of energy in the developer, which is not a trifling inconvenience.

With the employment of the mode of operating which we wish to see adopted, this inconvenience no longer exists, for the pure and concentrated iron bath retains not only all the energy, which by this quality is peculiar to it, but also works with all the desired regularity, even with a sensitizing bath highly charged with alcohol and ether.

The alcohol and ether of a bath become old by use; being the only obstacle to the regular action of the bath of pure concentrated solution of sulphate of iron, it would seem natural that, to cause it to disappear, it would only be necessary to warm the bath. The heat ought, in fact, to expel these two fluids. This method has been pointed out, but we have not had recourse to it; it seems to us too radical, if not suicidal. A bath which has become good by use is a thing too precious to allow us to decide upon submitting it to so violent a torment, exercised upon principles as yet but little known, and the association of which is, moreover, full of mystery. We preserve, therefore, the bath just as *nature* has made it; but if, to sensitize the plate, we leave it its alcohol and ether, there is no objection to removing them from the collodion film when it has been impressed by light, which we effect in the following manner.

The plate on being removed from the camera obscura is placed flat on the bottom of a dish containing sufficient rain or distilled water to cover it completely.

We then give a rocking motion to the dish, and continue it until the water flows freely over the film, which it does as soon as the greasy aspect disappears. The plate is next placed on the tripod, levelled, and covered with a weak solution of nitrate of silver (strength two per cent.), and this is allowed to act for a minute at most. At the expiration of this time we lift the plate and pour off the silver solution into a beaked measure, and allow the plate to drain thoroughly. Meanwhile, we have ready a flat bottomed dish containing the concentrated solution of sulphate of iron, to the depth of half an inch. Holding the plate by one corner, we place it vertically upon the bottom of the dish, and *at the same moment* drop it, by means of a hook, into the iron solution without the slightest hesitation or pause: it must be allowed to remain two or three seconds and then lifted out; if it has been exposed the right time, the image will appear with all its details.

* Continued from Vol. VI, p. 464.

It will also be understood, that if the concentrated bath possesses sufficient energy to cause all the details of the image thus to appear instantaneously, the proportion of silver is too feeble to give the desired intensity of tone. A new dose of silver must now be made to react upon the free sulphate of iron which covers the plate. To this end, the plate being partially drained, is again placed on the tripod, and inclined at a certain angle, and by the opposite corner pour quickly over it the silver solution reserved in the beaked measure. The silver solution must be made to flow over the plate as quickly and as evenly as possible, and repeatedly during several seconds, in order to facilitate and equalise the reaction. Immediately the blacks, which were very feeble, become strengthened in an extraordinary degree, and all the details gradually appear. In this case, the action is not instantaneous; we can continue it during three or four seconds, and it very seldom happens after the expiration of this lapse of time that the development is incomplete. However, if we wish for a still greater intensity of tone, we can drain the plate again, submit it for the second time to the developing bath, and a third time to the silver solution, and so on until the contrasts between the blacks and whites is satisfactory. But, we repeat, if the time of exposure has not been unreasonably short, and if the sensitizing bath be quite neutral, a first strengthening of the image will generally be found sufficient.

In the case where, by insufficient exposure, the negative remains weak, we can repeat several times the methodical strengthening with sulphate of iron and nitrate of silver, without exposing the picture to the thickening too frequently observed when employing pyrogallie acid; only, as the film too feebly impressed by light in the camera has not sufficient strength to retain the silver decomposed by the sulphate, it forms a pulverulent deposit which, by its mechanical adherence to the film, opposes itself to the ulterior electrical deposit, the only one capable of forming the image. In these conditions the defects of the photographic impression are manifested by a crowd of little white or grey points. We may avoid this defect by first filtering the iron bath, and also by washing the plate in pure water, in order to free it from every mechanical deposit, before submitting it to the two per cent. silver solution. If we have care to take these precautions for cleanliness at each alteration of the silver and iron solutions, it will very often be possible to bring out a good picture from an under-exposed plate, which at first we might have despaired of.

The electrical action in photogenic phenomena, of which we have spoken in a preceding article, appears to us particularly evident during the development with sulphate of iron. Upon the decomposition of the nitrate of silver by this metallic salt, an electrical current is established, possessing very great energy, which ceases immediately the decomposition is accomplished. By the effect of the imperfect conductivity of the bodies brought into contact, the duration of this decomposition is appreciable, and it is during this interval that the silver carried by its excess of electricity fixes itself upon the impressed iodide. This free electricity of the silver reacts upon the natural electricity of the iodide, or, rather, it combines with the opposite electricity of this body, rendered free by the action of light. Whatever it be, some molecules of silver, however attenuated, would never fix themselves upon the iodide of the film if they were not solicited on their own excess of free electricity; what proves this is, that upon the appearance of the image through the action of the sulphate of iron, there is a considerable excess of silver reduced, while a very minimum quantity is retained by the plate; only that which is in contact with the iodide impressed by light, the remainder, which is found outside the sphere of the electrical activity of the iodide remains in the bath, where its electricity is dissipated. If, therefore, we desire a new deposit of silver to take place, a fresh quantity of electricity must be disengaged, and this we always obtain when practising the artifice of strengthening as we have described it.

(To be continued.)

NEW PROCESS FOR POSITIVE PRINTING.

BY M. BERTRAND.*

This process does not differ in principle from that in ordinary use with chloride of silver. It consists, likewise, in impregnating the paper with a soluble chloride, which is transformed into chloride of silver, in exposing a paper thus prepared beneath a negative, and in fixing and toning. I do not enter into lengthy details, as the manipulations are nearly all the same as in the ordinary process.

I prefer the *papier de Saxe*; evenness of substance is not absolutely necessary, but sheets having spots of iron must be rejected.

The first preparation of the paper consists in impregnating it with a soluble chloride: it is immersed or floated in the following solution.

Alcohol (36°)	100 parts
Benzoin	10 "
Chloride of calcium	5 "

The most expeditious method consists in taking a dozen sheets of paper, and immersing them one by one in the bath, with the aid of a glass rod; when a certain quantity is immersed they are all turned in a heap, and withdrawn one by one, then hung up to dry.

The improvement effected by the benzoin consists in completely stopping the pores of the paper: air and moisture can no longer penetrate the proofs, which are thus protected from the principal, if not the only source of deterioration. The benzoin also imparts the gloss of albumen to the paper, but in a less degree.

This chlorided paper will keep a long time; it is sensitized by being placed in contact with the following bath.

Water	100 parts
Nitrate of silver	15 "

If it is desired to keep the sensitized paper a long time, it must be placed in a box with chloride of calcium.

The exposure under a negative is shorter than with albumenized paper: the proof is printed deeper than required ultimately. If the exposure is continued a long time, the blacks become dark green, but this need give no concern, as the toning bath restores the blacks.

For toning I employ M. Bayard's formula.

Water	1000 parts
Chloride of gold	1 "
Sal Ammoniac	20 "
Hyposulphite of soda	4 "

Or the acetate bath:

Water	1000 parts
Chloride of gold	1 "
Acetate of soda	30 "

Or any other toning bath.

The proofs rapidly assume a black tone, which is obtained with difficulty on albumenized paper.

They are fixed in

Water	100 parts
Hyposulphite of soda	20 "

When the proofs are well washed they are left to dry, then rubbed with a tuft of cotton wool, or a piece of flannel, to impart lustre. It must evidently be useless to varnish them.

—*Bulletin de la Société Française de Photographie.*

GLASGOW PHOTOGRAPHIC ASSOCIATION.

GRAND SOIREE, EXHIBITION, AND CONVERSAZIONE.

[FROM OUR OWN CORRESPONDENT.]

THE above interesting and long looked-for Soirée took place on Feb. 19th, under the auspices of the Council of the Association, in the Merchants' Hall: about 400 members and friends

* M. Bertrand first published his process in Paris, just prior to the publication of Mr. Cooper's; both gentlemen having been apparently experimenting in parallel directions. We should, however, recommend Mr. Cooper's last improved formula as the best.

assembled, but had the hall been able to accommodate twice the number, it is probable that it would have been filled, the demand for tickets being so great; but the Council deemed it better to limit the number to as many as could be comfortably accommodated. It would be well if this example were more often followed, for the practice is too general of issuing twice as many tickets as there is accommodation for, and the crush and squeezing often entirely spoils the pleasure of the meeting.

The handsome hall was decorated with an extensive and choice collection of photographs by the most celebrated artists of England and Scotland, also a quantity of apparatus contributed by Dahmeyer, Ross and other distinguished makers.

The meeting was presided over by Professor Allen Thomson, M. D., F.R.S., who was supported on the platform by Dr. Taylor, Dr. Penny, Dr. Rainy, Professor Wallace, Professor Blackburn, Jabez Hughes, Esq. (of London), E. Braze, Esq., A. Maetear, Esq., J. Stuart, Esq., A. Macnab, Esq., J. Jex Long, Esq., J. Spencer, Esq., and other gentlemen.

The proceedings of the evening commenced with a bountiful service of tea and coffee, an efficient band of music meanwhile enlivening the company with popular quadrilles, and operatic selections. Tea concluded.

The CHAIRMAN, Dr. Allen Thomson, apologized for the unavoidable absence of the President, and congratulated the association on their excellent attendance and splendid display, and trusted they would heartily enjoy themselves. He maintained that that association represented one of the "Wonders of the Age"—Photography. It was an art as remarkable for its rapid rise and progress as for the deep and subtle scientific principles on which it was based. It had arisen, not only in our own time, but almost under the eyes of the youngest amongst us. But a few years since, it was the latest marvel of science, and now it was practised everywhere. The early examples of the art were costly and imperfect, obtainable only by persons of means; its progress, however, had been marked by a series of rapid strides, and each step of progress has not only improved, but cheapened it; so that now, in its highest degree of perfection, it was within the reach of all. Thus had this philosophical wonder become almost a daily necessity, and, ministering to our feelings and affections, it was equally appreciated and patronized by the highest and the humblest in the land. He continued:

There is a combination of science and art—of fine art and the highest taste—that secures approval for photography wherever it goes, and makes it one of the most delightful occupations that can be followed. I think it may be viewed in various aspects. I take first that which suggests itself the most readily to the mind and heart, its social aspect. Where is the house you enter now that you do not find portraits of beloved friends and valued scenes, remembrances of every description by the photographic art? Who is there now who has not his large album of cartes de visite, or his small and cherished collection? A friend of mine gave me an illustration of this the other day. He met an old woman, and he asked her about her children. "Where," said he, "is Maggie, where is Betty, and where is Tom, and so on?" Well, he got an account of them all. Tom was gone to Australia; Maggie was married, and gone to Canada; and Betty was gone to New Zealand. "But," said the old woman, "here they are all in my pocket." (Laughter.) "I will show you their husbands, and Tom's wife and bairns, and I have got pictures of the cottage which they have just built, and the place is beautiful." This is a simple picture of what occurs in almost every family of the present day. I say it is a picture of the social aspect of this art of the most agreeable and delightful description. (Applause.)

The Chairman then alluded to the general improvement in taste, and this he attributed to a considerable extent to the influence of photography. No doubt such great Exhibitions as those of 1851 and 1862 produced powerful influence, but to this art must the greater effect be due, and no more striking proof could be given than the almost entire suppression of miniature painting, and the commoner form of oil painted portraits. These were avowedly ill-drawn, even when well painted, and at best unsatisfactory representations, and he had no hesitation in saying, that even an ordinary photograph of the present day, by virtue of its truthfulness and accuracy, stood higher as a work of art, and was of more real value to its possessor, than many of the costly and pretentious productions of days past. Some persons objected to photographic portraits because they did not make more pleasing likenesses; this he thought was more often attributed to the sitters themselves than photography, for it must be remembered that it was the person himself who pro-

duced the expression that was copied on the plate. He thought this subject was likely to engage the attention of the public more than it had done, as he found many persons who really did study the pose and expression, with the view to aid the artist and secure a better photograph. Still, for his part, he was a great advocate for truth, and if the frown was habitual on the brow, he did not see why it should not be on the photograph too. (Cheers.) It was to be regretted that doubts still existed as to the ultimate permanency of the prints. Yet as so much advance had been made, he doubted not that science would speedily solve this problem, and that the certain stability of the prints would be one of the earliest improvements recorded. Allusion was then made to the usefulness of photography in fostering and diffusing a taste for the fine arts by reproducing, for comparatively trifling sums, copies of the celebrated statues of antiquity, of the pictures of the best masters, of the choicest examples of the architecture of all lands, as well as some of the most beautiful and interesting scenes in Nature.

After alluding to the utility of photography in copying objects in natural history, historical monuments, rare manuscripts, &c., he enjoined the company not to neglect the opportunity of a close inspection of the exquisite works before them, as it might be long before they again had so favourable an occasion.

The band now performed a variety of popular airs and a choral party sang quartettes.

Mr. E. BRACE (Hon. Secretary to the association) delivered a very interesting address, in which, after alluding to the rise and progress of the art, he contrasted it twenty years ago, when practised only by Claudet and Beard, to its present diffusion, where almost every village has its professional artist.

He had been at some pains to collect a few statistics on the subject. He found by consulting the Directories, that in London there were 194 professional photographers; in Liverpool 51, Manchester 49, Glasgow 38, Edinburgh 33, and Aberdeen 15. He was aware that these figures very much understated the real numbers, as there were many photographers whose names were not in the Directory, yet even these showed that there were nearly 400 photographers in the three principal cities of England and Scotland. But this did not represent in any degree the number of persons employed; as, in every establishment there are several assistants.

In one establishment in London, there were last season nearly 100 hands engaged, and in many the number were over 50. He proposed to assume on an average, that there were ten assistants, this would show 4,000 persons employed. The wages earned varied considerably, according to skill and ability, but if each were paid £1 per week, this estimate would show that nearly a quarter of a million sterling was paid per annum as wages for photographic assistants. These figures, however, let it be understood, bear reference, not to the United Kingdom, but only to the three principal cities of England and Scotland, and therefore gave but a very imperfect sketch of the real number of persons employed in photography, or of its value as an industrial art. As an enormous quantity of gold and silver was consumed in the production of photographs, he had endeavoured to get an approximate idea of the amount. He had put himself into communication with two of the largest houses in the trade, and from the data supplied, he found that during 1862, there were 152,216 ounces of metallic silver consumed, nearly 4½ tons of the precious metal. So large an amount might be supposed to influence the currency, fortunately, as yet, it had not done so. This silver was converted into upwards of 240,000 ounces of nitrate.* He had endeavoured to form some idea of how many pictures could be produced by this amount of nitrate of silver. Here he entered more into the region of surmise, but he took it for granted, that, though a good deal of this nitrate of silver was consumed in the production of negatives, yet that the great proportion was employed in sensitizing the paper. He thought he was also justified in assuming, that during the past season the bulk of this nitrate was used in the production of cartes de visite. By a comparison of notes with an eminent photographic friend, based on the number of grains of nitrate of silver required to sensitize a whole sheet of paper, and the number of cartes de visite that could be produced by this whole sheet, he had come to the conclusion, making

* As Mr. Brace derived his data from two wholesale houses only, and as one of these is not by any means the largest manufacturer, it is probable that the amount is much understated. Perhaps 500,000 ounces of nitrate of silver would be a more accurate estimate, but allowance must be made for a considerable quantity of the precious metal that is recovered from cuttings and waste solutions.—Ed. P.N.

allowance for the small proportionate amount required to produce the negative, that each carte picture represented a grain of nitrate of silver consumed in its production. If, then, every grain of nitrate of silver represented a card picture, this amount of silver would show the enormous number of 105,441,129 pictures produced during 1862; and further, if one shilling be taken as the average paid for each of the pictures, it will be seen that photographers have received no less than £5,272,064 odd, for their productions during the past year. He also found from the data supplied by these two wholesale houses that, to improve the tone of their pictures, and give them increased permanence, photographers had consumed during the year past 3,000 ounces of metallic gold, which, at £30s. 6d. per ounce, represented £9,075. Although the conclusions he had drawn could only be regarded as approximate, yet they would show the enormous scale upon which this art was practised. This would also be established by the large sums that were allowed by the refiners for the clippings, cuttings, and waste solutions of some of the principal London photographers. He found that sums so large as £200, £300, and even £400 had been paid during the year for these waste products.

Mr. Brace then proceeded to call attention to the more remarkable pictures exhibited on the walls. There was first the large view of the Broomielaw by their President, Mr. Kibble. This picture was taken several years since, and the character it then held of being the largest photograph ever taken is still maintained, for no one had since taken a picture so large. The size of the negative was about 44 inches by 36 inches, and he was pleased to say it was as perfect as it was large. There were also many of Mr. Kibble's instantaneous views, which were most perfect examples of that branch of the art. There were also the exquisite landscapes of their townsman, Mr. Annan, which would bear advantageous comparison with the works of the best artists in that line. Attention should be given to two perfect pictures by a Glasgow amateur, Mr. Church, which had had prizes awarded to them in London for their excellence. They had also a beautiful winter scene; a prize picture, too, by the Earl of Caithness, who had shown in photography as in other branches of practical science. There were also excellent examples of the skill of their local artists, in coloured and other portraits, particularly the popular cartes de visite of Messrs. White, Douglas, Macnab, Stuart, Bowman, Alexander, and others. There is another department in which, considering the smoky, foggy, atmosphere of this city, we could never expect our artists to shine, and yet to Glasgow had been awarded the palm for excellence in solareamera pictures. On the walls they would see the productions of Mr. Stuart. Some of these were on exhibition now in London, and they had there been acknowledged to be unequalled. But unless, smoky Glasgow has more than one artist destined to shine in this branch. Since Mr. Stuart's works have been seen and admired, Mr. Douglas has also exhibited a solar picture; it is on the walls to-night for you to admire; and if this be but his first attempt, as I understand it is, considering the known skill and ability of the artist, I ask, what may we not hereafter expect from him? Among the strangers, they had some excellent Scotch views by Roger Fenton, scenes in Egypt and the Holy Land by Frith, Roman views by Macpherson, and Venetian by Ponti.

Mr. Brace then alluded to his own experience as an amateur; he had had much pleasure in practising this fascinating art, but he had too little time to devote to it. He had had his troubles and difficulties like all others, but whenever he got into a mess he had only to go to one of the professional brethren, who were always ready with advice and assistance. As an amateur, he tendered his thanks to the profession for their readiness always to open the stores of knowledge accumulated by their daily experience, for the benefit of persons who, like himself, had little time to make experiments or mature improvements. He had also great pleasure in bearing testimony to the excellent feeling that animated the professional brethren. They met in the Society, read papers, and compared experiences, and with an utter absence of trade rivalry and jealousy, seemed animated only with the feeling to improve each other and advance the art.

After some more music, the Chairman invited the company to leave their seats and examine the pictures exhibited. He also desired them to descend in small parties to the hall below, where Dr. Taylor's Photographie Diorama was fitted up. This exhibition, invented by Dr. Taylor, late Professor at the Andersonian University, has already been described in the PHOTOGRAPHIC NEWS, Vol. VI. p. 603, and *passim*.

Among the views exhibited was one that created a great sensation, "The Governor's House, Calcutta," as seen with the crowds of natives in front, on the occasion of reading the Peace Proclamation. The picture is first seen in sunlight, then illuminated at night with the coloured lamps on the scaffolding in front of the house, then the display of fireworks and rockets produced a most marvellous effect. A view of Bowling Bay, with the shipping, was very pretty, especially when seen under a variety of atmospheric effects; but perhaps the most remarkable was a view of Holywood, first seen in broad sunshine, then twilight, then moonlight, and finally a torch-light procession of priests in full canonicals, bearing the Host, completes the illusive and romantic scene. The exhibition of the Diorama was superintended by the Doctor himself, to whom the thanks of the Association is due for this interesting portion of the evening's entertainment. He was ably assisted by Messrs. Macnab and Bowman.

After the interval allotted to the examination of the pictures, &c., the company re-assembled, and after being regaled with a service of fruit, the music playing the while, their attention was called to an exhibition of the electric light by Mr. J. W. Stone, preceded by a brief lecture by Professor Wallace, descriptive of the peculiarities of the light. After a few illustrations of its intense power, with and without the reflector, the most interesting photographic feature of the evening occurred, the attempt in the presence of the audience to take a photograph by the electric light. The necessary apparatus being all at hand and a plate prepared by Mr. Maetear, the electric light, by the aid of the reflector, was thrown on a wall covered with photographic pictures. Great doubt was expressed whether the light was intense enough to produce a negative in any reasonable time; twenty seconds' exposure was tried, and in a very few minutes the word was passed to the Chair that the picture was perfectly successful. It was then proposed to try a more interesting object, a portrait. Another plate being prepared, Mr. Jabez Hughes was requested to sit quite steady, and with the audience on-looking, the portrait was duly attempted. Some thirty or forty seconds were given, and after a few minutes the gratifying intelligence came that the portrait was all right, but rather over-exposed. The dripping negative was speedily passed from hand to hand and declared to be a great success.

The CHAIRMAN then called on Mr. Hughes as a gentleman formerly known as a successful practitioner amongst them, but now present as a guest for a few words.

Mr. JABEZ HUGHES responded with a short enthusiastic address, comparing photography in Glasgow to what it was when he first came among them, when there was only one besides himself practising professionally. He also complimented the Association on the high position they held among photographic societies, and their great success was the more gratifying to him as he was one of the founders of the first Glasgow Photographic Society, and had had the honour of contributing the first paper ever read to them.

Mr. MACTEAR delivered a humorous and amusing narrative of the many comic mishaps to which newly-fledged photographers are subject, which excited great amusement and laughter.

An exhibition of photographs in the magic lantern followed, the slides being principally England's beautiful views in Paris, Canada, the United States, and particularly Niagara Falls.

During the interval that had elapsed from taking the electric light negatives, some of the friends had copied them as transparencies, and these were exhibited in the lantern and formed an important finale to the exhibition. The unexpected appearance of these pictures on the screen caused the greatest delight, especially the portrait of Mr. Jabez Hughes, which called forth rounds of applause.

It will be seen that the programme for the evening was of an exceedingly varied and pleasing character, and the entertainment from first to last gave universal satisfaction.

Thus closed the most brilliant and successful meeting ever held among the photographers of the West of Scotland, and the greatest credit and honour is due to the Glasgow Photographic Association for providing so interesting a meeting and setting such an excellent example to other photographic societies.

THE APPLICATION OF PHOTOGRAPHY TO THE MAGIC LANTERN EDUCATIONALLY CONSIDERED.

BY SAMUEL HIGHLEY, F.G.S., &c.*

As I have been requested to give the same subject before the Society of Arts, I shall this evening dwell upon the artistic section of my series, concerning such subjects as Kaulbach's "Reynard the Fox," and the pictures of Hogarth and Schnorr, more in accordance with the taste of this society—while on the 14th inst. I shall give my entire series of scientific objects, as being completely suited for the members of a society that have always been ready to promote scientific educational appliances.

SCIENTIFIC SUBJECTS.

GEOLOGICAL.—Penrhyn Slate Quarries—*Silurian Formation*. The Crater of Etna—*Volcanic*. PALEONTOLOGICAL.—Fossil Pterodactyle of the *Solenhofen Limestone*.—RESTORATIONS of Pterodactyle, by Waterhouse Hawkins—of the Wealden Epoch, by Professor Unger. BOTANICAL.—*Phyteleptas Macrocarpus*, or the Ivory Palm—Group of Japanese Fruit.* ZOOLOGICAL.—*Fredericella Sultana* (*Polgzoa*)—*Sepia Officianalis*, or Cuttle Fish (*Cephalopoda*)—*Rhizostoma Cuvieri*, or Jelly Fish (*Hydrozoa*). ASTRONOMICAL.—The Moon at full. ETHNOLOGICAL.—A Japanese Family.* OSTEOLOGICAL.—Skull of European. MICROSCOPICAL.—*Pinnularia* (*Diatomacea*)—Flea of the Hedgehog—Parasite of the Flea of the Hedgehog—*Acaris* of the Hedgehog—*Acaris* of the Sparrow—Section of Tooth of *Labyrinthodon*. GEOGRAPHICAL.—Views of the Falls of Niagara (from the negatives of Mr. England). BIOGRAPHICAL.—The Princess Alexandra.

ARTISTIC SUBJECTS.

Kaulbach's Illustrations to "Reynard the Fox."

Goethe's poem of "*Reineke Fuchs*" was thus epitomised by Mr. Highley.

View 1. King Noble the Lion summons all animals, both great and small, to his court at the Feast of Whitsuntide. 2. Reynard the Fox, conscious of evil doings, flinks it better to stay at home and enjoy his *otium cum dignitate*. 3. Sir Isegrim the Wolf, Frizepate the Poodle, Tybalt the Cat, and Fang the Panther, all bear witness against their neighbour Reynard, but Greybeard, the Badger, his nephew, and only friend at Court, swears that Reynard is leading a most irreproachable life, and that his accusers were themselves accomplices in his former misdeeds. Unfortunately, Chanticleer the Cock arrives with a fresh grievance, and the body of his favourite daughter Greyleg, who has been foully garotted unto death by Reynard. 4. The Cock depicts how Reynard, with sanctified men, gained access to the bosom of his family ere he treacherously betrayed his trust. 5. The King sends Bruin the Bear to summons Reynard to answer for this crime. 6. Reynard, however, on the way, leads Bruin into a trap by raising visions of unlimited honey in the hollow of a tree, and makes his way home, while Bruin meets with an *overpowering* reception. 7. King Noble, greatly enraged at his first ambassador's mishap, sends Tybalt to command Reynard's attendance, trusting that Wit and Wisdom might accomplish what Strength failed in. 8. Tybalt fares no better, and Greybeard undertakes to bring him before the King by force—*of persuasion*. To him Reynard makes confession, of how he led Isegrim to commit a *fovil* murder, and thus *take a false step* in life. 9. Reynard brought to trial, unable to contend against the charges brought against him by bird and beast, is condemned to death. 10. But, in his last dying speech and confession, Reynard turns the tables on his enemies, and by a story of buried treasure, of which he induces Puss, the timid hare, to swear he knows the hiding-place, manages to gull the King, and save his own neck. 11. Having thus risen in royal favour, and secured the imprisonment of his foes, he determines to make a pilgrimage to get out of harm's way, and receives an earnest exhortation from Bellyn, the Prelate Ram. 12.† Bellyn and Puss accompany him on the way, and inducing the latter to pay his wife a lying-in visit at his residence in the cave of Malepartus, he cannot resist the temptation of making a meal of his unsuspecting victim. 12. Bellyn, unaware of the fate of his companion, is induced by Reynard to take back a missive to the King, which proves to be (when the

wallet is opened) the head of poor Puss. King Noble in his wrath, sacrifices Bellyn as a peace-offering to Bruin and Isegrim, whom he releases from prison *instantly*. 13. The Court holds a festival to do homage to Bruin and Isegrim, who are reinstated in royal favour. 14. Reynard again induced by Greybeard to go to Court to clear his character, takes a tender farewell of his family. 15. Dame Ruckeuaw, the She Ape, and favourite monthly nurse in the King's family, pleads Reynard's cause. 16. Reynard applies the fable of the Ass, the Man, and the Spaniel to his own case. 17. And reminds the King of how his father, who was in the medical profession, through his skill, saved the life of the King's sire. 18. And relates how his arch enemy, Isegrim, got himself into trouble, in the baboon's den, by using uncourtous language to her and her family. 19. Isegrim having challenged Reynard to mortal combat, Reynard prepares himself, both inwardly and outwardly, for the encounter, under the guidance of Dame Ruckeuaw. 20. In the contest (by means of his tail, moistened and dragged on the ground), throws dust in the eyes of his enemy, till having blinded him, he falls upon him tooth and nail, and thus gains the victory over Isegrim. 21. *Being* victorious, all the beasts, *of course*, hail Reynard as conqueror: some Ass recites an ode: lauding his mental, moral, and bodily excellencies; and even the ladies look upon him with eyes of favour. 22. King Noble confers upon him the highest dignities of the animal kingdom. 23. During which time Isegrim, surrounded by his family and friends, suffers mortal agony. 24. Reynard, overpowered with honours, retires into the joys of domestic life.

"The Life of Christ," from Schnorr's "Bible Pictures," Hogarth's "Good and Idle Apprentices," and Hogarth's "Finis," concluded the series.

Beyond the department I have specially dwelt upon this evening, I may say a few words upon the Educational value of Stereographs, but only a few words, for every one must have felt their value, but, unfortunately, they have never been published in a systematic form, so as to give them a true value for the purposes of scientific instruction, but if systematically produced, the Schoolmaster, the Provincial Lecturer, and the Professor of Natural History, might bring many unique specimens, scattered through the museums of the world, within the ken of their pupils; in fact, the treasures of our British Museum might be carried in a professor's coat pocket. Such productions ought to be accompanied by descriptive letter-press, and this leads me to the application of photography to book illustration.

I was one of the first—I believe *the* first—who applied photography in this direction, for, in 1852, I illustrated a paper in the "Quarterly Journal of Microscopical Science," of which periodical I was the projector, and (at that time) proprietor, with an 8vo page plate, containing two enlarged photographs of microscopical objects, with the "imprints" exactly in counterpart of a lithographic, steel, or copper-plate print.

These two subjects were printed at one operation, on a single 8vo page of albumenized paper, in such a manner as to avoid the consumption of time and expense over the usual process of "mounting," a matter of great importance when a thousand copies had to be in the binder's hands on a given day. I subsequently published a second book illustrated with photographic plates, viz., an English edition of Dr. Unger's beautiful work on the restoration of the fossil Flora and Fauna of the different geological epochs, bearing the title, "Ideal Views of the Primitive World."

Having had some experience in this direction, I feel bound to state that we can never look to the present method of producing photographic prints, if we wish to apply the art to the purposes of book-illustration, for the cost of each print is too great for popular educational adaptation; but there is a method to which I look with hope, viz., the photo-galvanographic process of Mr. Paul Pretsch. By this invention, the counterpart of wood blocks can be produced from a photographic negative; and every publisher will, I think, back my assertion that this is the right and principal direction in which experimentalists should work; and I trust to see the day when Mr. Paul Pretsch's unwearied labours will be, as they deserve to be, crowned with complete success. For every bee in the great hive of science should sympathise with the labours of his fellow bee, while deploring that the awards and honours of the land fall too often to the share of the drones. In conclusion, I would say that every exploring expedition should be accompanied by its official photographer; that every national museum, observatory, and hospital should have its appointed operator; and

* Continued from p. 93.

† From the negatives of Messrs. Negretti and Zambra.

then the hoped-for time may come, when we can, in a systematic manner, place the records of scientific travel, the transcripts of Nature's treasures, and the history of the progress of fell disease, upon the screens of our lecture theatres, the stereographs of our cabinets, and the pages of the books in our libraries.

(To be continued.)

Proceedings of Societies.

NORTH LONDON PHOTOGRAPHIC ASSOCIATION.

The usual monthly meeting of the society was held in Myddelton Hall, on the evening of Thursday, February 18th; Mr. G. DAWSON in the chair.

The minutes of a previous meeting having been read and confirmed, the following gentlemen were elected members of the society:—Messrs. Parsons, Smith, James Howe, and T. Heritage.

Some specimens of the alleged spirit photographs were examined, and briefly discussed, the general impression being one of amusement at the clumsy imposture.

Mr. HILL called the attention of members, to the advantages of focussing with plain glass instead of ground glass, a much sharper image being obtained.

Mr. WHARTON SIMPSON said the method had often been recommended; Professor Emerson had especially called repeated attention to the advantages of the method. It was necessary to use a focussing glass, focussed upon the surface of the glass by means of a scratch. The naked eye might easily be deceived by seeing the image through the clear, at a little distance from it.

Mr. MARTIN said, that Messrs. Horne and Thornthwaite had long been in the habit of having a portion of the ground glass quite clear, so as to get the most delicate portion of the image quite sharp, magnifying it with an inverting eye-piece.

A desultory conversation on the subject followed, in which Mr. Simpson said an excited collodion plate was an excellent substitute for ground-glass, when that got accidentally broken. The Chairman remarked that nothing could be better, and it had the advantage of being always at hand.

Mr. SQUIRE exhibited several fine pictures taken with Shepherd's leuses, also some examples of metal printing frames, with facilities for printing several card pictures in one frame; and a Collman Sellers rolling press.

Mr. SHADBOLT exhibited a number of card portraits, some of which were by an amateur, some by Mr. Robison, some by Mr. Bannister, and others by Mr. Wenderoth, of Philadelphia. He was induced to bring the latter pictures before the meeting again, because he feared the last time they were examined they scarcely received justice from being shown in the rough, unmounted.

Mr. SIMPSON remarked, that at their best estate they were not very good; they were very hard, and devoid of half tone. They were not a fair sample of American photography, which was usually very good.

The CHAIRMAN said they were certainly hard and poor, not equal to some of the amateur pictures then before them.

The specimens by Mr. Bannister were produced, it was explained, from negatives on curved glass.

Mr. HILL said that probably accounted for the distortion observable in the background objects.

Mr. SHADBOLT said he thought the curve was so slight, only one-tenth of an inch rise in the middle of the plate, that it would not produce any perceptible change in the lines. He thought Mr. Hill was deceived by the ugly ill-drawn background. Anything more hideous he had never seen.

The CHAIRMAN said with respect to the curvature of the glass, twelve months ago Mr. Ross had tried hard to induce photographers to use such plates, but he (the Chairman) had always felt that they would not willingly use anything which involved much extra trouble. It was certainly a pity that since the distortion and astigmatism introduced by the endeavour to produce flat fields could be got rid of by using a curved glass, that photographers would not do it.

After some further conversation, and some routine business in nomination of officers to be elected next month,

Mr. REJLANDER, having apologized for not being prepared with a proper paper, read some desultory observations on "Art-Photography," illustrating his remarks by some very fine photographic art studies, which were examined with much interest, after which the proceedings terminated.

The International Exhibition.

REPORT OF THE JURY ON PHOTOGRAPHY AND PHOTOGRAPHIC APPARATUS.*

In proceeding to some brief considerations of those contributions in Class XIV., which possess especial interest, the Jury feel it important to state that the limits of this Report preclude the possibility of any extended notice of even the most meritorious works, and to add, that silence in reference to any contribution must not be understood as necessarily implying any want of merit in the work, or of interest on the part of the Jurors, their object in the following comments being chiefly to direct attention to such contributions as, apart from their individual merit, are possessed of features interesting to the public, or to those interested in the art, either professionally or as amateurs.

APPARATUS, &c.

To commence with the means, before entering on results, we shall refer to the apparatus first, and here it is necessary to say, that the high excellence of the photographic appliances in the British department was worthy of every commendation.

The uniformity of this excellence was such as to present some embarrassment to the Jury, and they felt it impossible to make a distinction by awarding a medal to any, whilst every contribution was worthy of honourable mention. They have pleasure here, therefore, in recording the fact, that it was rather from equality of excellence, than from inferiority in any respect, that medals were not awarded to apparatus in the British department of Class XIV.

UNITED KINGDOM.

3033 AUSTEN, W. (H. M.)—This contributor is the inventor and manufacturer of improved rolling machines for closing the fibre of the paper upon which the photograph is printed, and giving it an ivory-like appearance; also of camera-stands made of iron with universal motions, together with various iron head-rests. The advantages claimed for iron over wood consist in its freedom from warping or shrinking in changes of temperature, and in securing rigidity and firmness without cumbersome bulk. The rolling presses exhibited appear to be singularly well made and efficient. The bed, instead of consisting, as is usual, of a plate of steel fastened on wood, is of one solid piece of cast steel. The head-rests are provided with ball-and-socket joints, which afford great facility of adjustment. One of the rests for standing figures is provided with a support for the back as well as the head, which materially contributes to comfort and firmness whilst standing for a portrait. The contributor deserves commendation alike for the ingenuity of his applications, and the excellence of workmanship in his apparatus.

3043 BLAND and Co. (H. M.)—This firm exhibit a variety of cameras, baths, shutters, vessels, &c., which are made with an especial view to the changes of temperature and other trying conditions found in India and other tropical climates. Not simply in the designs and in the perfect seasoning of the raw materials is this purpose remembered, but in the mode of workmanship, &c., glue not being relied upon for the adhesion of the parts, an excellent universal camera is shown which may be used for stereoscopic pictures, or album portraits; it may be employed in the field as well as in the glass room, being equipped with a series of frames for dry plates, as well as with the usual appliances for wet processes. The camera is provided with an arrangement for sliding the lenses inside, for the convenience of packing; a convenient and portable chemical chest accompanies the camera. The water-tight bath exhibited has the cover conveniently attached, which prevents the chances of mislaying; at the bottom of the mahogany outer case is an opening which permits the contents of the glass bath to be examined. An ingenious instantaneous shutter, closing with a spring, is also exhibited; and a variety of other cameras, &c., combining many improvements with good quality and handsome design.

MESSRS. BLANN and Co., as wholesale agents, exhibit the only collodion to which a Medal was awarded, that of Mr. PONTING of Bristol (3136). This collodion, on trial by the Jury, fully bore out the reputation it has obtained amongst practical photographers as extremely rapid, and giving very perfect delicate negatives, full of half tone and brilliancy. The stability of this collodion is a feature to which the Jurors call especial attention. At the period when the trial was made, the sensitive collodion had been prepared some months; and as some of the members had been in the habit of using the same preparation, they were enabled, by their individual experience, to confirm and endorse the results of the trial then made as to the high character for sensitiveness and stability of this collodion.

3047 BOUQUIN and Co. (H. M.)—A variety of cameras and camera-stands, albums, &c., are exhibited by this firm. The camera-stands are good in design and workmanship. A large camera, combining a multiplicity of objects, being suited for copying and enlargements as well as for ordinary purposes, and extending from four and a half to forty inches, possesses many excellent qualities. The albums by this firm are superior in design material, and manufacture, the tint of the paper giving the best effect to the photographs mounted therein.

3053 BELL, J. T. and G. (H. M.)—A variety of pictorial backgrounds and profiles; accessories chiefly intended for use in the production of carte de visite portraits; they demand attention from the variety of the designs and from the novel application of the art of the scene-painter as an auxiliary to that of the photographer.

3064 COX, F. J. (H. M.) contributes a variety of excellent apparatus, amongst which may be named an instantaneous shutter, which is placed between the anterior and posterior lenses of a portrait combination in contact with the central diaphragm; a dark slide or "camera shield" which revolves and exposes alternately different parts of one large plate, and permits several different pictures to be taken on the same glass; a plate containing seventeen different portraits being exhibited as an illustration; these portraits are glass positives of great brilliancy, and are stated to have been produced by

* Continued from p. 58.

Fisher's positive collodion, and developed with a solution of proto-nitrate of iron with formic acid.

3069 DALLMEYER, J. H. (Medal).—The contributions of this exhibitor consist of a variety of photographic lenses and apparatus.

The lenses for the great excellence in which the Medal was awarded, consisted chiefly of double and triple achromatic combinations possessing novel features of great importance. The triple achromatic lens invented by Mr. Dallmeyer consists of three achromatic lenses, the front and back of which are positive, the central one being negative. In each of these combinations the combined surfaces are cemented, thus giving the same number of reflecting surfaces as the ordinary portrait lens. The negative central lens is of the exact form and power required to correct the central and eccentric pencils, and this with full aperture. The triple lens is free from chromatic and spherical aberrations. The images produced by this lens are quite free from distortion; a wide angle of view, with good definition, is included by it. For copying and architectural purposes it is especially valuable, giving perfectly straight lines, a flat field, and great equality of illumination and definition. In the hands of the Jurors these qualities have been satisfactorily proved, and in the beautiful landscapes produced by this lens, and exhibited in the building, additional confirmation is obtained.

Several quick-acting lenses, with flat field and fine definition, especially adapted for card portraits and other larger pictures have been invented by Mr. Dallmeyer. A double combination, especially designed for instantaneous stereoscopic views, and also a lens adapted for enlargements, specimens of which are exhibited by Mr. T. K. Williams (3182).

The medal has been awarded for the introduction of novelties as well as for unsurpassed excellence of manufacture.

Some excellent samples of apparatus, consisting of cameras, instantaneous shutters, are also exhibited. A camera for carrying two stereoscopic lenses possesses a moveable front and diaphragm, which permits it also to be used with one lens for producing landscapes $7\frac{1}{2}$ by 4 $\frac{1}{2}$. The use of the double rack and pinion for adjusting the focus by sliding the front body of the camera is worthy of notice.

3071 DAVIS, T. S. (H. M.), contributes a photographic manipulating camera. It consists of a small chamber, with drapery to surround the operator, forming a dark tent; the chamber is fitted with bath, dishes, and other requisites; the lenses are attached to the front of the chamber, and the focusing screen is fixed inside, the plate being withdrawn from the bath *in situ*, and exposed and developed without the operator leaving his position in the dark tent formed by the drapery attached to the chamber. This contrivance is in some respects similar to Arber's camera, and is very compact and convenient for operating in the field.

3080 HAAR, G. (H. M.). Cameras of very excellent quality, well seasoned and well made; a portable stereoscopic camera and improved Kinneer's camera were both worthy of attention. Mr. Haare manufactures largely for the wholesale trade.

3095 HIGLEY, S. (H. M.).—A variety of contributions are shown by this exhibitor, who received an award for the general excellence of his apparatus, consisting of a photo-micrographic camera for taking enlarged photographs of microscopic objects; a photographer's actinometer, by which the time of exposure required in a given light of any class of objects, may be tested; a new form of dropping bottle for nitrate of silver; solutions, acids, &c.; an improved pneumatic holder; a photographer's travelling lamp to be used when developing, and a portable tripod developing stand. Much ingenuity of contrivance is displayed in all these articles.

3097 HOCKIN and WILSON (H. M.).—Apparatus and chemicals of great excellence are displayed by this firm, amongst which may be named an instantaneous shutter made of brass, closing with a spring; vessels of ebonite for photographic purposes; hermetically sealed tubes, or bottles for collodion, ether, and various other chemicals.

The chemicals are of great purity; the collodion, a preparation of which Mr. Hockin was one of the earliest manufacturers, is possessed of great intensity, and for many purposes is highly valuable. They also exhibit a portable tent intended for field operations.

3099 HOCKIN and WILLIAMS (H. M.).—The contributions of this firm consist of a variety of photographic chemicals of great purity, and of which they are the manufacturers on a large scale for supplying retail dealers. The samples exhibited fully sustain the long-established reputation of this house for the care used in securing purity in their productions.

(To be continued.)

Photographic Notes and Queries.

CONTINUED USE OF THE SAME TONING BATH.

DEAR SIR,—For some time past I have meditated laying before you one of my experiences on the much vexed question of Alkaline Gold Toning, and some remarks in the paper of your able correspondents. "A Photographic Assistant," on the subject of old gold baths, makes me think this the fitting opportunity to do so.

In lieu of making a fresh bath for each batch of prints, I have for some months past been in the habit of continuing to use an old one over and over again with a result fully satisfactory to myself both as to the tone arrived at and the economy of the gold, having always been able to reach it with purple tint approaching to black without the smallest tendency to that dreaded arch-enemy mealiness. I have invariably found on first using a new bath that the prints, though of satisfactory tint on leaving it, receded to a sepia tint in the hyposulphate of soda; but this never occurs on the second using, and it is a great convenience, as an amateur, to be able to work off one or two prints at a time by having a bath constantly ready.

The course I pursue is to make the bath with distilled water, and having inserted in it a small piece of litmus paper, add in small portions at a time bicarbonate of soda until the blue

colour is all but restored; then, from time to time, if the bath becomes inert, I add from 6 to 8 drops of a 4-grain gold solution (or more if so large a number of prints have been through as to nearly exhaust it), which at once sets up the action, and in extreme cold I have sometimes warmed slightly to save time, I do not find that it requires further alkalizing, or that I get any large precipitate of gold thrown down. I may add that I usually print on the albumenized paper of the London Stereoscopic Company, floating two minutes in a bath made at 100 grains to the ounce, and never allowed to fall below 90 grains, and thoroughly washed before toning.

In all this I may be telling you nothing new; and, if so, have to crave your pardon for troubling you; but I have never met with it in print or practice; and if you think it likely to be useful to others, I shall be much gratified in having contributed my mite to the general stock.—I am, yours obediently,

F. LANE.

P.S.—I enclose a small print as a specimen of tone.

Rotherham, Feb. 6, 1863.

[The print enclosed is an architectural subject; the tone a good purple black.—ED.]

MORPHINE DRY PROCESS.

DEAR SIR,—In reply to your correspondent's inquiries, ho must obtain the *miriate*, not *acetate*, of morphine, dissolve it in a little water, add it to the bath, and filter out the chloride or muriate of silver, when the *nitrate* of morphine remains in solution, which salt is, I believe, not manufactured for sale. As to the exposure required in this process, all I can say is that the plates are very sensitive, may be requiring half as long again as a wet plate. I generally varnish round the edge of the plate before development, and do not use any coating above or underneath the collodion. I have only worked stereoscopic plates, on account of the increased expense of large ones, but I see no reason why an edging of varnish should not do for them also, especially with a non-contractile collodion; there is no wrinkling and loosening of the film, as in the tannin process. It is important not to use water containing lime, or much inorganic matter in solution; filtered fresh fallen rain water is good; after excitation immerse in a vertical bath of this water, giving an up and down motion to the plate for fifteen seconds or so; then, after an interval of a minute or two, immerse in another lot of water, and so on, to get rid of all the nitrate. For development, I far prefer iron to any other agent, and from my experience with it on these plates, it appears to act thus: if under-exposed, the picture lacks detail and intensity, after one application of developer; another will increase the detail, and, if necessary, a third dose or fourth will augment the half tones, and not much increase the density, which must then be gained by the use of pyro and silver. If, on the contrary, the plate has been fully exposed, the iron developer will bring up the whole of the detail on the first application, and a second will increase the density very much. I have taken many stereo negatives, which were completed with two doses of iron, and a few drops of silver solution added on using. In making a new bath, I expose it to the light for a week or so, which facilitates the deposition of a black powder, which is then filtered out, and the solution will keep much longer in a clear state afterwards, although it is always good for use if filtered.—I am, dear sir, yours respectfully,

WM. BARTHOLOMEW.

Farnham, Surrey, Feb. 22, 1863.

PHOTOGRAPHIC HALF-HOLIDAY.

DEAR SIR,—Will you kindly insert in your next Friday's NEWS, that an attempt is now being made to afford all those who are engaged in photography the benefit of the Saturday half-holiday, by soliciting the various photographers in the city to close their respective establishments at two o'clock on Saturday afternoons throughout the year, commencing March 7th (the day on which the Princess Alexandra passes through the city.)

The time of closing (two o'clock), has been chosen, as in many houses it would be impossible for business to be concluded, and negatives varnished, &c., before three o'clock, so that the latter may be calculated as the hour of leaving.

I trust that all who are concerned in photography will give this movement their warmest support.—I remain, dear sir, yours truly,

H. J. GOLDBOLD.

[We very heartily commend this suggestion to employers,

and may add our conviction, that in granting the boon, it will not be all loss to them, as their operators will doubtless work with renewed zest and energy in consideration of such a privilege. It would, moreover, afford to some the opportunity for occasionally trying a landscape, an opportunity for which those constantly immured in the operating room often sigh and hope at present in vain.—Ed.]

ENLARGING WITH A STANHOPE LENS.

DEAR SIR,—I think your correspondent, Mr. Leary would find that in using the Stanhope lens for taking photographs of microscopic objects, the double combination of lenses has the effect of neutralizing to a considerable extent the coloured fringe which surrounds the object when seen with the Stanhope lens only. The use of the Stanhope lens was only advocated by me as a *cheap* means of taking these photographs, or studying the structure of insects and plants. If only the latter object is desired, we have a very cheap contrivance with the Stanhope lens, costing 2s. 6d., and a long deal box, with the bottom made to slide (in the centre of which the Stanhope lens is fixed), and the top fitted with a piece of ground glass, which box any carpenter would make of deal, for a trifle.

I think, for enlarging from small negatives, a large double-bodied camera of deal, painted black, is certainly the cheapest, and perhaps the best apparatus for the purpose; indeed, I cannot say that I see any great improvement upon the method of enlargement, which I have used for years, and a description of which will be found in the first volume of the NEWS. I think we shall never get a really satisfactory enlargement of a portrait until we get a film on the glass that will bear magnifying to the required size without showing the structure; all the enlarged photographs that I have seen look as if the sifter were pifted with the small-pox, which does not improve the appearance.

I have noticed some remarks in recent numbers of the NEWS, on the use of "Ammonia nitrate of silver in alcohol," for albumenized paper. I have found the formula, mentioned in vol. i. page 141, to answer well with some albumenized paper, but in many cases, it has dissolved the albumen; perhaps floating for a very short time would succeed, as the solution penetrates the paper almost immediately, or using more silver, only, in that case, I think the paper must be used immediately after sensitizing, as even with ten grains to the ounce it soon begins to change.—Believe me, my dear sir, yours very truly,

THOMAS BARRETT.

Miscellaneous.

PHOTOGRAPHS IN PRINTING INK.—A correspondence has recently taken place in the *Times*, which illustrates how amusingly uninformed even the intelligent portions of the outside world remain as to progress and capabilities of photography. First a paragraph appeared announcing an "Important Discovery in Photography." This, however, merely turned out to be Mr. Pouncey's process, the alleged discovery being the production of photographs in printing ink, and was stated as follows:—"This ink is mixed with certain chemicals, and spread completely over the paper intended to be submitted to the action of the rays of light through a negative; and the secret consists in rendering it so sensitive that an indelible photograph may be fixed on the paper, leaving the other portions so free as to be easily washed off. The time required for exposure is comparatively short, and the advantage is, besides that of permanence, the fact of the subject being fixed, developed, and, as it were, completed without the various manipulations required under the old system. The superfluous ink is removed by spirits in ten minutes or a quarter of an hour, displaying a picture for delicacy of tone, beautiful gradation of light and shade, and minuteness of detail fully equal to anything heretofore obtained in photographic printing." A letter from Mr. Osborne followed, correcting the erroneous notion that the application of printing ink was a new discovery, and briefly detailing the history of its application, first, in 1859, by M. Asser; next by himself, and subsequently by Col. James: all of whom not only produced photographs in printing ink, but also transferred them to stone for reproduction by a printing press. He adds:—"That Mr. Pouncey may have a special method of his own I do not doubt, nor do I wish to take from him any of the merit to which he is entitled; but to the statement that the results he has obtained are perfect,

or excellent, I must demur, if we are to judge by the specimens exhibited by him at a recent meeting of the Photographic Society, and by the manner in which they were received by the members present." Mr. Paul Pretsch next writes claiming the invention as early as 1854. There is just this distinction to be made, however, between the latter gentleman's ingenious methods and those before referred to:—The former refer to producing from a negative an image on paper in printing ink; the latter to the production, by the aid of a negative, of a plate or block from which to print in the ordinary way. In fact, Mr. Pretsch incidentally indicates the difference in his communication: he claims, simply, reproducing photographs in printing ink; the other claims are for producing them direct from the negative.

STEREOGRAPHS OF THE MOON.—A singular question as to certain photographs of the moon recently published in a work entitled "Our Satellite," by Dr. Le Vengeur d'Orsan, has been raised by the *Athenaeum*, in which a possible case of disgraceful piracy is involved. The *Athenaeum*, in a recent number, says:—"Looking at one of Mr. De la Rue's photographs of the moon, we were struck with its minute resemblance to one recently published by Dr. D'Orsan—even to the appearance of a casual flaw in the glass. Whereupon we asked the question—When was Dr. D'Orsan's negative taken? In reply we have a letter from J. B. Morgan, the Doctor's Secretary, from which we quote this passage:—"Dr. D'Orsan always treated such covertly scurrilous personal attacks with dignified indifference, and would also meet those recently made with contempt, did not the interests of his publisher render the publication of an authorised contradiction of the recent mis-statements a matter of necessity." Unhappily, the Doctor's Secretary forgets to answer the question put. As we are not told when Dr. D'Orsan's negative was taken, we are unable to say which of the two lunar photographs before us was the original." In a subsequent number, a letter from Messrs. Smith and Beek appears, in which they distinctly charge Dr. D'Orsan with piracy from a stereoscopic transparency by Mr. De la Rue, published by them. "The proofs of this statement," they say, "are as follows:—Not only are the photographs exactly similar as regards both lunation and libration, but the very flaws in the collodion film of the original negative are reproduced in Dr. D'Orsan's prints. One of the most prominent of these flaws is situated in a small plane to the N.W. of Tycho, between Orontius and Sasserides. It appears as a white speck on the collodion film of the original negative, and is reproduced as a black marking in the positive print published in the stereoscopic slide. It is reproduced again in both photographs of Dr. D'Orsan; thus proving, not only the source from which he has obtained the photographs, but that both his published photographs, although professing to be taken at different lunations, are from one and the same photograph. In one of them the outlying parts around Tycho have been carefully expunged. There are at least half-a-dozen flaws reproduced, but the above-mentioned is, we think, sufficient." In reply to this, Mr. Bennett, the publisher of Dr. D'Orsan's work, states that this gentleman is willing to show to any scientific gentleman, his original negatives, and the date of their reproduction, proving their priority to those of Mr. De la Rue. He adds, that "to distinguish between minute flaws in the negative, and hitherto undiscovered 'flaws,' so to speak, on the surface of the moon, would require a most accurate and critical series of observations." For the present, the matter remains there. The quarrel is a very pretty one as it stands. Since the above was in type, Mr. De la Rue has written a voluminous letter with illustrations, to the *Athenaeum*, in which he very satisfactorily shows that Dr. D'Orsan's published photographs are simply unauthorized copies of his own. Mr. Bennett, Dr. D'Orsan's publisher, has also written to state, that, having applied in vain to that gentleman for dates, and a sight of his negatives, he has come to the conclusion, that it is not in Dr. D'Orsan's power to produce evidence to overthrow the grave charges made, and that until such evidence is forthcoming, the publication of "Our Satellite," will be discontinued.

LECTURES ON PHOTOGRAPHY.—We find, from a Berkshire paper, that a lecture on photography was recently delivered at the Working Men's Institution at Newbury, by Mr. E. T. Brooks a professional photographer in that town. We think that much might be done to place correct notions of our art in the public mind, by popular lectures of this kind, and remove fallacious notions. The subject could always be made interesting.

Talk in the Studio.

PHOTOGRAPHIC EXHIBITION.—We must remind our readers that the Exhibition closes on the 2nd of March, and that it is now open in the evenings.

SOUTH LONDON PHOTOGRAPHIC SOCIETY.—We are requested to inform the members of this Society that the address of the secretary, Mr. Alfred Harman, is now, 7, Gunnersby Villas, Harter's Road, Peckham, S.E. Mr. Harman has recently dissolved all connection with his late partner, Mr. Dages, and is now engaged in business at the above address.

BULLOCK'S MOUNTING MACHINE.—This is a cleverly contrived aid to the mounting of card portraits. A raised plate, the exact size of the print, is fixed in the centre of a piece of mahogany. At each end is a hand or "gripper" resting on a spring; these hold the print in its place whilst it is pasted. The card is then laid upon it, the edge touching certain guides which give exactly the right margin on the card. The points are then slipped off the print, the card pressed down, and the operation is complete. Perhaps this seems more complicated in description than it is in fact; and we are assured that a great saving of time and increase in the neatness of the mounting is obtained by the use of this little contrivance.

SUTTON'S PATENT ALBUMENIZED PAPER.—We are informed that the manipulatory difficulties attending the production of this new paper are now nearly, if not entirely, removed, and that Messrs. Lampray, Tibbitts and Co., will be prepared shortly to supply it to the public. We have seen some proofs on this paper produced in an early stage of the experiments when the *modus operandi* was in a comparatively crude state, which were highly satisfactory. The surface of the paper being peculiarly delicate and grainless. The advantages claimed for this paper are, mainly, that it has an unusually fine surface, that it produces a better tone, and greater detail, especially in very deep shadows; that it is free from meanness, and that really bad prints are almost impossible. We understand that shortly a fine collection of prints on this patent paper, the production of different distinguished artists, will be ready for inspection at the establishment of the manufacturers. Some of the prints are on tinted paper, producing a very pleasing effect.

To Correspondents.

*** Several columns of Advertisements are compelled to stand over for want of space.

PHOTOGRAPHIC NEWS ALMANAC, AND YEAR-BOOK OF PHOTOGRAPHY.—This work is now reprinted, and is ready for issue.

PHOTO. A.—The streakiness in the direction of the dip may arise from several causes. A very common and generally efficient remedy is the addition of a little acid. It will sometimes arise from the accumulation of ether and alcohol in the bath, and in that case, removing these by evaporation is necessary. It will sometimes occur from the presence of organic matter in the bath, in that case, a simple remedy, generally efficient, is the addition of a little bicarbonate of soda, just sufficient to cause a slight precipitate, which is not redissolved on agitation. Then place the bath in the sun for an hour or two, and afterwards filter, and if necessary, acidify. A strong bath generally favours vigour, but increases the tendency to stains.

S. CHESTER.—The line to which you refer means simply what it says: "distilled water 1000 grains;" that is, 2 ounces and 40 minims of distilled water; but we phrased it in the words of M. Jeanrenaud.

R. T. W.—The specimens are very creditable for an amateur with few opportunities. You will obtain a better idea of your chances as an operator and of the remuneration, by answering some of the many advertisements for assistants which constantly appear in our columns, than we can give you. 2. Chloride of lime is often used for cleaning or removing discolouration of engravings; but we cannot tell whether it will remove the stains to which you refer.

J. R. H.—The rapid discolouration of the silver bath often proceeds from some peculiarity of the albumenized paper; but we have not met with a case which resisted attempts to clear by citric acid, kaolin, &c. We can only recommend you to make the bath neutral, or slightly alkaline, and then add solution of citric acid until a precipitate takes place; this will most likely clear it. Sunning the bath after it has been rendered alkaline, will also clear it. When using common water you should not add any acid or you may dissolve some of the insoluble salts which helped to keep the bath clear.

F. L. E.—There are several methods of photographic engraving by the aid of bitumen. You will find a summarised history of several on page 71, vol. i., of the PHOTOGRAPHIC NEWS; on page 247 of the same volume you will find particulars of the original process of M. Nicéphore Niepce; on pages 133 and 158, of our second volume, you will find a process by M. Bertchold. The most detailed account of the process of M. Nicépce de St. Victor and M. Lemaitre, that we know, is given in Monckhoven's *Traité Général de Photographie*, of which a new edition has just been published.

JUSTITIA.—A photograph published or sold before the passing of the New Copyright Act is not protected, and you have no remedy against the piracy. 2. The defect in the pictures received is *meanness*. Many remedies have appeared

in our pages, many of which are at times useful; but sometimes the defect seems to defy all remedy. Read the various articles we have published on the subject. The defect is much more common with thin than with vigorous negatives. There are no especial instructions to be observed in making the acetate bath, beyond following the formula, and keeping the solution a few days before using it. 3. You have light too evenly all round the sitter; more side light and less front light is desirable, this will give more vigour and roundness to your figures.

J. BURGESS.—Your letter did not contain the sample of paper alluded to. Albumenized paper prepared with fresh eggs, and 24 grains of chloride of ammonium will doubtless make a good paper, but will require a very strong silver bath. We should prefer half the quantity of chloride.

M. A.—Ammonia-nitrate, when successfully worked, gives very rich deep tones; but there is no fault to be found with the tones of the cards enclosed. 2. A newly iodized collodion, especially if it contain cadmium, generally has a tendency to give veiled negatives. It sometimes happens that the veil does interfere with the quality of the print, if the relations between lights and shadows are properly preserved; but it retards the printing very much. 3. As a general principle a bath for landscape purposes will bear more acid than one for portrait negatives. If your tannin plates have a tendency to fog, the bath should have more acid. 4. The PHOTOGRAPHIC YEAR-BOOK is reprinted. The Photographic Exhibition closes on the second of March.

A CONSTANT READER.—If albumenized paper be quite dry when placed in the printing-frame, it ought not to cockle. It is probable that the back of the frame is damp in such case. 2. A piece of felt is a good thing to place upon the print in the frame. 3. When the free nitrate solution collects on the plate in streams during exposure, it indicates that the plate had not been sufficiently long in the bath; that the collodion is of a very repellent character, and may be remedied by the addition of a drop or two of distilled water, or that the bath is very old. We do not like redipping in the bath as it often causes fog. 4. The imperfect surface to which you refer is too generally described to enable us to help you. If we saw a specimen we could perhaps give some advice. 5. The cause of varnish cracking has been the subject of much discussion; it is generally believed that damp is the primary cause. 6. We prefer the lenses of the best English makers to any French ones.

R. G.—It entirely depends on the size of a dish, whether one made entirely of gutta-percha, or one of wood lined with gutta-percha, will be cheaper. If very large, the latter will probably cost less and be more useful. 2. To precipitate silver from hypo solutions, use liver of sulphur.

NO NAME.—We received an envelope from some of our correspondents, posted in the West Central district, in which the letter had been omitted. The envelope was unsealed as well as empty, with a note on it from the local postmaster saying it was received so. This being the case, we do not know whether the letter had never been put in, or lost out, only that we have nothing to answer.

An article on "Glass Rooms," with a Diagram of Mr. Rejlander's studio, together with several other articles and "Critical Notices" are compelled to stand over for want of space.

Several Correspondents in our next.

Photographs Registered during the Past Week.

- MR. A. LANE, Hungerford, Berkshire,
Photograph of the "Meet" at the Marquis of Aylesbury's.
- MESSRS. C. A. DU VAL AND CO., Exchange Street, Manchester.
Photograph of Robert Maclure, Esq.
" S. J. Stern, Esq.
" Lord Edgerton, of Tatton.
" Robert Gladstone, Esq.
" John Platt, Esq.
" William Roberts, Esq.
" Nathaniel Bekersley, Esq.
" Edmund Ashworth, Esq.
" Hugh Mason, Esq.
" Abel H. Heywood, Esq.
" Colonel Wilson Patten, M.P.
" Lord Derby.
" J. W. Maclure, Esq.
" Thomas Ashton, Esq.
" Rev. J. Wyld.
" Sir J. P. K. Shuttleworth.
" Rev. E. Hornby.
Two Photographs of Rev. E. Birch, Chaplain to H. R. H. Prince of Wales.
Photograph of G. E. Ashworth, Esq.
" R. H. Hutchinson, Esq.
" Dr. Molesworth.
" Richard Ansell, A.R.A.
- MR. FREDERICK L. SLEDON, Derby House, Edge Hill, Liverpool,
Three Portraits of Rev. Thomas Moore, St. Stephen's Church, Liverpool.
- MR. WILLIAM DOWNEY, 9, Elton Square, Newcastle-on-Tyne.
Photograph of John Bright, Esq., M.P.
- MR. JOHN STUART, 120, Buchanan Street, Glasgow,
Photograph of Rev. James Macnaught.
- MR. WILLIAM GEORGE HELSBY, Crosby Green, West Derby, Liverpool,
Photograph of Valparaiso.
" Professor Sammelson.
" Robinson Crusoe's Cave, Juan Fernandez.
" The Ruins of Tia-Huamaco.
Vignette Portrait of Rev. J. Stevens.
- MR. PETER SKELAN, 12, Promenade Villas, Cheltenham,
Photograph of Rev. Gordon Calthorpe.
Portrait of Rev. Alfred Barry.
" Rev. George Roberts.
- MR. CHARLES MONSON, 12, Bridge Street, Northampton,
Photograph Group of H. R. H. Prince of Wales, Earl Spencer, &c.
- MR. EDWARD SMITH, 8, Old Bond Street, Bath,
Portrait of Mr. Edwin Sturge.
" Dr. Marks.
- MR. JAMES G. TUNNY, 93, Princes Street, Edinburgh,
Portrait of the Hon. Theresa Yelverton.

THE PHOTOGRAPHIC NEWS.

Vol. VII. No. 235.—March 6, 1863.

CONTENTS.

	PAGE		PAGE
Glass Houses and Lighting	109	Proceedings of Societies	114
Photographic Exhibition.—Final Notice	110	Correspondence:—Iodides and Bromides in Collodion—The	116
Collodion Formulae.....	111	French Photographic Exhibition	118
New Fixing and Developing Agents. By M. Meynier	111	The International Exhibition.—Report of the Jury	119
On the Decomposition of Tannin Plates. By Stephen P. Leeds	112	Photographic Notes and Queries	120
On Composition Photographs.....	112	Talk in the Studio	120
The Application of Photography to the Magic Lantern Educa-	113	To Correspondents.....	120
tionally Considered. By Samuel Hihgley, F.G.S., F.C.S. ...	113	Photographs Registered during the Week	120
Copper-Plate Printing by Photography	114		

GLASS HOUSES AND LIGHTING.

From the frequent inquiries which reach us, asking for advice and information relative to the building of the glass-house, and lighting of the figure, we are led to believe that few subjects are more interesting, or less understood, amongst photographers. Whilst it is difficult either to deal with such a question in the abstract, or prescribe rules of universal application, we can occasionally give illustrations of specific cases, and suggest general principles.

We do not know of any photographer who has produced more artistic pictures than Mr. Rejlander. One of the first reflections which strike us, on looking over a collection of these photographs, is the unusual command over the lighting of the model which the artist possesses: almost every variety of lighting is adopted in turn, to serve some specific purpose, and always successfully. To the education of an artist, Mr. Rejlander has added years of practice as a photographer, not simply in manufacturing conventional portraits, but in producing art studies, in which every possible effect of lighting is in turn necessary. Mr. Rejlander has recently erected a new studio in London, a brief description of which cannot fail to be interesting to our readers, not necessarily as a model to be imitated, but as illustrating the principles of lighting, which may be adopted or modified as circumstances may render necessary. We should state at the outset that the chief aim in the present studio is to secure a mode of lighting similar to that used by painters, so that the photographic studies obtained may be strictly available for painters, the same conditions of light and shadow existing in the photograph, which are required in the painting. That the same light will often be valuable for portraiture, and general photography, we see no reason to doubt; the only misgiving we have on the subject, being in relation to the amount of light, which we fear would scarcely be found sufficient for convenient working in dull weather. Here is a sketch of the erection.

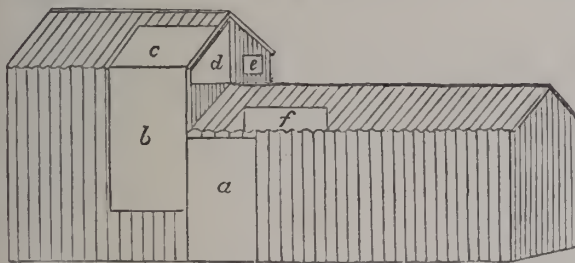

It is built of corrugated iron; and the total length is thirty feet. The portion devoted to the sitter is ten feet long and eleven feet wide. The remaining twenty feet curving in near the door, and becoming narrower, so that, at the extreme end, where the dark room is, the width is seven feet. The light is obtained solely from the white spaces *a, b, c, d, e, f*, in the diagram, the light falling from

the north-west. The door *a* consists of a plate of glass, seven feet high by three feet wide. The window adjoining, *b*, consists of another plate of glass, seven feet high by five feet wide; this joins another plate, *c*, in the roof, which is five feet wide and three feet deep. These three are of white plate glass, and constitute the chief source of light. On the opposite side there is no glass at all, but the interior is painted white to secure reflected lights. The minor lights, *d, e*, and *f*, will generally be covered with blinds, their object being to secure not direct light, but diffused light, and thus aid the reflections.

It will be seen that the sitter is lighted from the side and side top: front light, and direct vertical light being entirely avoided. The absence of sash bars is in Mr. Rejlander's opinion a great advantage to the sitter and to the picture. The effect of these bars on the eye having a painful sensation, interfering with natural expression, and spoiling the beauty of the eye in the picture. The camera is in comparative darkness, enabling the operator to focus without the aid of a dark cloth over his head. The eye of the model also looks into this darkness, by which is gained the double advantage of comfort to the sitter and expansion of the pupil of the eye, giving it more depth and expression. Nothing is more offensive in a photographic portrait than the light unmeaning-looking eye, which often results from the sitter looking towards the light, in which case the pupil contracts; and, if the irides be blue or grey, giving at once a weak, fishy, washed-out effect to eyes, which, in the original, probably look dark and bright, and beaming with expression.

We may here subjoin a diagram, showing the longitudinal section of a glass room proposed some time ago by Mr. Sutton, to which Mr. Rejlander's is very similar in principle.

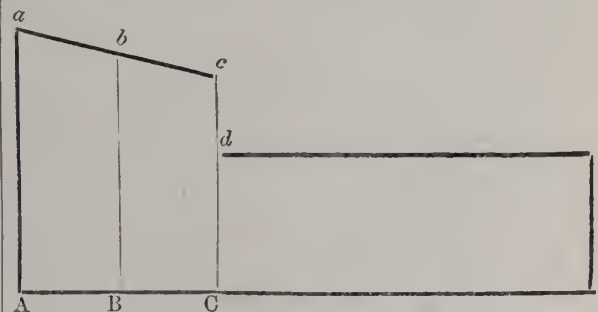

The total length here is supposed to be thirty-six feet, of which twelve feet, *A, B, C*, constitute the glass room proper. *A, B*, on each side, is opaque, and *B, C*, on each side, glass, from top to bottom. This, with the small portion, *c* to *d*, at the front of the glass room, and adjoining the narrow passage, is all the glass the building will contain, the remainder being a long, dark passage, as in

Mr. Rejlander's studio. The end, A, at which the background will be placed, must be south, so that the light reaches the sitter from the north. The windows, facing east and west, must be furnished with blinds, one of which, according to circumstances, will always be down, just allowing sufficient light to pass through, to serve as reflected light.

The front top window, *d*, it is recommended, should be made to open and fall back upon the roof of the passage, so as to let in air and more light in fine weather. The chief objection to this also is that existing in Mr. Rejlander's room, namely, that in dull weather, and amid the smoky atmosphere of large towns, such a room would often be found to be too dark for practical purposes of portraiture, so that it is desirable to have facilities for getting in more light when necessary. In Mr. Sutton's design we conceive it would be an advantage, instead of continuing the opaque roof of the glass room over the entire space, *a, b, c*, to let it be opaque merely over *a, b*, the glass then commencing and sloping to the roof of the dark passage, forming a line from *b* to *d*. This would give more light without serious sacrifice in other respects.

In both these designs it will readily be seen that excellent principles of lighting are involved, which are well worthy of consideration. Not the least of the benefits to be secured consists in cleanness of the shadows, and consequent brilliancy without much intensifying, as there is scarcely any chance of that bane of iron development—deposit on the shadows from diffused light entering the camera. For further details on the subject of erecting glass-houses and lighting the sitter, we refer our readers to an article in the YEAR-BOOK OF PHOTOGRAPHY for 1863, which is just reprinted.

PHOTOGRAPHIC EXHIBITION.

FINAL NOTICE.

The number of reproductions in this exhibition is not large. With the exception of three or four very fine things by Mr. Annan, and a few others we have noticed before, the copies of Turner's paintings by Mr. Thurston Thompson are the only reproductions worthy of mention in the exhibition. These are, as a series, perhaps, the most perfect copies of oil paintings which have ever been produced by the aid of photography. It is a somewhat singular fact that pictures, the great charms of which consist in their gorgeous colouring and wondrous aerial perspective, rather than in sharply defined drawing, should, in the photographic monochrome, so accurately render the feeling and characteristic style of the master; yet, it is a fact, that in no copies of paintings we have before seen, is the photograph more satisfactory, or the original painting more ably translated into monochrome. Here is "Spithead" (241), which will rival any engraving possible of the same subject, as a picture, whilst, as a study of Turner, not the most admirably drawn copy by hand can compare with it. "Venice" is a picture consisting of little more than sunlight and atmosphere, which seems to robe every object in a fairy-like veil; it is one pre-eminently difficult from which to produce an effective photograph; yet in the copy before us there is the perfect suggestion of the original, which it enables us to bring most vividly before the mind's eye. "Carthage" is one of the most glorious pictures of the series, and a perfect study of atmosphere and composition. Mr. Thompson has conquered all the difficulties which might readily have been supposed insurmountable in photographing these pictures; the glowing colours, the indefinite drawing, the heavy impasting and peculiar handling, have all yielded to the skill, taste, and experience brought to bear in copying them; and it is a matter of congratulation for the public, that probably the only opportunity which will occur—the removal from one gallery to another—was seized for obtaining such invaluable transcripts. We are glad to be able to state that this series will shortly be published, and afford every

admirer of Turner, and every student of art or of photography, the facility of obtaining some of the most valuable contributions which photography has yet made to art. Mr. Thompson exhibits some other copies of pictures, and few photographs of *bas reliefs*, in terra-cotta we believe, by Clodion. There is also a copy of a marble bust by Hiram Powers, "Proserpine" (254), which is as perfect a specimen of delicacy, roundness, and satisfactory rendering of texture as we have ever seen.

The London Stereoscopic Company exhibit a fine collection of their admiral photographs of objects in the International Exhibition, which we have noticed before, and which all the world knows by this time to be almost as perfect as photographs can be.

Mr. Stephen Thompson exhibits some photographs of sculpture, amongst which we may name copies of Foley's Egeria, both the bust and complete statue, as possessing considerable force and delicacy; a little more reflected light in the deep shadows would, we think, have more accurately rendered the texture of marble.

Amongst instantaneous photographs, claiming especial pre-eminence as being unsurpassed for beauty, and unequalled for size, are the pictures of Col. Stuart Wortley, consisting chiefly of scenes in Italy, and possess, in almost every instance, clouds of most wondrous beauty, in combination with sea and foreground. The sweep and dash of the waves, the smoke of Vesuvius in the distance, mingled with the grand masses of cloud, are all very beautiful and effective. The modes of producing these pictures was recently very fully and lucidly described in our pages. A strongly bromized collodion; a nitrate bath containing a full dose of nitric acid; an iron developer with formic acid; a 6 by 5, or 8½ by 6½ triple lens with full aperture, for pictures on 10 by 8 or 12 by 10 plates; intensifying after the plates are dry with mercury and an iodide, followed by pyrogallic acid and silver. These give, in all photographic respects, such softness, detail, clearness, brilliancy, &c., as much perfection as the pictures possess in an artistic sense. Col. Stuart Wortley also exhibits a few very perfect tannin pictures, which leave nothing to be desired; one of these has also had an instantaneous, or very rapid exposure.

Mr. Blanchard's stereographs are the only other instantaneous pictures on paper exhibited. Mr. Wilson does not contribute at all this year. Mr. Blanchard's pictures consist of instantaneous views of London and the Thames; busy, bustling, street scenes; and combinations of water, shipping, and magnificent clouds. It is unnecessary to dwell further on these pictures than to state that in their especial line we have not seen them surpassed, and rarely equalled.

There is a good display of instantaneous transparencies this year. Mr. Breese has two tables, each with eight stereoscopes, containing his exquisite transparent slides, with rare moonlight and sunset effects, and breaking waves, which, for absolute instantaneity, we have rarely seen equalled. Mr. Fry has a table with very fine transparencies, some of which are equal to those of Breese, but do not receive so much justice from being exhibited in inferior stereoscopes. Mr. Blanchard exhibits some of his charming pictures as transparencies; but these, like those just mentioned, suffer from the stereoscopes in which they are exhibited. Some of the same slides shown in a column stereoscope, exhibited, we believe, by Mr. Hare, are seen to much greater advantage. Messrs. Ferrier and Soulier exhibit a number of instantaneous and other transparencies of most exquisite quality.

A number of the very fine photographic enamels of M. Lafon de Camarsac are exhibited. Some very good photographs on porcelain, or enamel glass, are exhibited by Mr. Portbury. These, with the charming photographs on silk, by Mr. Cooper, are the only departures from the usual routine as to the basis of the picture.

The room devoted to pictures by French photographers, contains many valuable illustrations of processes, amongst

which we may name Corbin's dry collodionized paper process; Poitevin's and Fargier's carbon processes; Poitevin's photolithographic process; Negre's photo-engraving process, &c. The specimens of the latter are accompanied by some of the plates, and are not only interesting as illustrations of processes, but very excellent as results. M. Lemerrier exhibits some very perfect photolithographs by Poitevin's process. These are so good, and possess so much of half-tone, that we should have been very glad to know something more about them, especially how many stones were employed in producing the charming view of Alpine scenery. M. Charavet's specimens of carbon prints, by Fargier's process, hung beside the silver prints from the same negative, are exceedingly satisfactory. It is true, they lack a little of the brilliancy and transparency of the silver print, but they are, nevertheless, very excellent, as are also M. Lafon de Camarsac's specimens of the same process. The specimens of enlarging by M. Bertesh are exceedingly good: the detail is amazing, but either from the fault of the original lens, or that used in enlarging, the amount of distortion is very offensive.

We are here reminded that we omitted to notice in the proper place, a frame of carbon prints by Cecil Walker and Son, from being mis-classed under the head of collodion in the catalogue. These contain several specimens, which are very little, indeed, inferior to silver prints, and afford hope of the eventual possibility of obtaining prints entirely permanent without sacrificing delicacy or beauty.

A few specimens of apparatus are exhibited, but not such as call for especial notice. The exhibition is now closed, and there is, we fear, one drawback to its generally satisfactory character: it has not paid, and the sales have been small. The dull season, the out of the way position of the gallery, and a variety of other causes, have tended to bring about this result, which is, however, much to be regretted. The exhibition has been an exceedingly good one, and, on the whole, well managed, and, except financially, has, we believe, given general satisfaction.

COLLODION FORMULÆ.

THOSE who are in the habit of experimenting in the preparation of collodion will, probably, like to try the following formula communicated by M. Jeanrenaud to the *Moniteur de la Photographie*. To counterbalance the drawback of complexity which seems to characterize it, is the strong recommendation of the author, who possesses a high reputation. It is stated to give delicate results, to be very rapid and durable, improving rather than deteriorating with age. Here is the formula:—

Soluble cotton	8 parts
Pure ether	800 "
Alcohol sp. gr. 830	250 "
Iodide of cadmium...	9 "

Dissolve and add to 35 ounces of collodion 25 of pure bromine. To 3 ounces of the collodion then add 12 drops of strong liquid ammonia. A deposit is thrown down which may be re-dissolved by adding a few drops of glacial acetic acid. The three ounces are then added to the remainder of 35 ounces, and the whole left to settle for a fortnight. If it retain a straw colour, it is fit for use; if it be colourless, add a few drops of bromine.

M. Jeanrenaud also gives a formula for dry collodion as follows:—

Take ordinary collodion, and add to it 5 per cent. of a solution of ether saturated with yellow amber; the sensitizing bath consists of from 7 to 8 per cent. of nitrate of silver, and 2 per cent. of glacial acetic acid; the plate is then washed in four or five waters. The development may be effected either by the ordinary bath of sulphate of iron, or with pyrogallie acid. When the plates are large, it is necessary to fix the film around the edges by means of some varnish, either with alcohol or chloroform. M. Jeanrenaud found plates so prepared as sensitive, after

the lapse of a month, as when first fixed. The time required is about double that of the wet process, and for landscapes varies from three to seven minutes, according to the light and the season.

NEW FIXING AND DEVELOPING AGENTS.

BY M. MEYNIER.

1. Struck, on the one hand, with the danger incurred by photographers of being poisoned by the daily use of *cyanide of potassium* as a fixing agent, one of the most violent poisons that modern chemistry has produced; and desiring, on the other hand, to escape from the serious inconveniences presented by *hyposulphite of soda* of sulphurizing the proofs in the course of time, and of precipitating sulphur upon the slightest contact with any acid, I have searched among the chemical salts to find one which, without having properties injurious to the health, possessed the useful qualities in photography, as fixing agents, of the hyposulphite and cyanide above mentioned. I have been more successful than I anticipated, for I have found a salt which accomplishes the object in view in the most complete and satisfactory manner: this salt is the *sulphocyanhydrate of ammonia*, which hitherto has not been manufactured, nor for which has any use been suggested. This salt must be employed in the following manner:—To fix direct negatives and direct positives upon glass, a solution is made of the strength of 30 per cent. in pure water, and when the proof has been washed, a quantity of the solution is poured over it sufficient to cover it. The salts of silver unacted upon by light disappear from the proof as by magic, which assumes an opaline aspect, and upon being again covered with the solution, the proof is washed and remains perfectly fixed.

To fix positives on paper we employ a weaker solution of the strength of 12 per cent. only. The proofs being washed upon removal from the toning bath, are immersed in a dish containing the solution of 12 per cent., and allowed to remain in it five or six minutes, and then removed to a dish containing clear water. The water becomes thick; the proofs thus washed are again placed in a second bath of the solution of 12 per cent. and left in it for two or three minutes, then withdrawn and submitted to a methodical washing as when hyposulphite of soda is employed.

2. Every photographer who has employed sulphate of protoxide of iron as a developing agent, is well aware how quickly this salt is decomposed by contact with air. They have also experienced the inconveniences arising from its developing the picture unequally, of spotting and fogging, without it being possible to foresee such results. I have sought for a salt of iron, which, while it possessed all the developing properties of the sulphate, was exempt from its defects, and I have found that the *double sulphate of iron and ammonia* possess all the useful properties of the simple sulphate without having any of its objectionable qualities; it is unchangeable in the air, it develops the photographic image completely, and what is still more important, it requires a shorter exposure in the camera.

It is employed in the following manner. I dissolve 5 drachms of the salt in 100 drachms of water, and add to the solution 20 drachms of dilute acetic acid at 8° and 10 drachms of alcohol at 36°. The solution is employed in the usual manner.*

Upon this communication M. Davanne makes the following observations.

I have this morning tested in my laboratory the two substances which M. Meynier proposes to employ in photography.

The double sulphate of protoxide of iron and ammonia, dissolved in the proportion of 5 drachms of sulphate to 100 drachms of water, 20 drachms of pyroligneous acid and 10 drachms of alcohol, developed negatives with perfect detail and uniformity. The time of exposure was only twenty

* We have recently made trial of this double salt, see paragraph on last page.—Ed. P.N.

seconds for a portrait of medium size made with an objective of 4 inches diameter: nevertheless, the proof came out well, full of detail in the shades; and if there be not, as I am, however, tempted to believe there is, acceleration in the time of exposure, I can say that this developer acts as rapidly as the ordinary solution of sulphate of iron in the best conditions. It has an advantage over the latter in not being decomposed under the influence of the atmosphere, the double sulphate of iron and ammonia being much more stable than the ordinary sulphate, and, therefore, admits of a more precise formula.

The sulphocyanhydrate of ammonia has also been tested as a fixing agent:—Firstly, for negatives, employed in a saturated solution, it was sufficient to pour it upon the negative to perceive the layer of iodide of silver disappear as rapidly as when we employ for the same purpose a solution of cyanide of potassium of the strength of 3 per cent.; but it presents the advantages over the cyanide of not being poisonous, of not exhaling the cyanhydric odour, and if the negative has been badly washed and still retains salt of iron, instead of the greenish blue film which is precipitated on contact with the cyanide of potassium, sometimes straining the pictures, we only see the liquids take a red blood colour which disappears upon being simply washed.

I have also experimented with the sulphocyanhydrate of ammonia for fixing positive proofs; this substance is an energetic solvent of the salts of silver, and I feared to see that it would act like the cyanide of potassium in corroding the proof; but such was not the result, this fixing agent respected the half tones as much as the hyposulphite of soda does, and appeared to act like it in the different phases of the fixing; the proof must, however, be toned deeper than usual, because it more readily returns to its red colour. This first experiment at fixing, made hurriedly, under unfavourable conditions upon positives which had been some time printed, has, nevertheless, sufficed to show that we can succeed with it, and I think that by studying it carefully, we may obtain as good results as with hyposulphite of soda, over which the sulphocyanhydrate of ammonia presents the advantage of not giving spots while fixing, and especially of not giving free sulphur, which seem a guarantee of permanency for photographic positives.—*Bulletin de la Société Française*

ON THE DECOMPOSITION OF TANNIN PLATES.

BY STEPHEN P. LEEDS.

At the last meeting of the Photographical Society I presented to the notice of the members some tannin plates, which were prepared in the latter part of April last, strictly according to Mr. Russell's process—with the exception that the plates were coated with albumen, diluted with 3 parts of water to 1 part of albumen—and which were taken by me to Mexico, and exposed there in the camera, during the months of August and September, and brought back to this city, and developed during the present month. These plates presented such a novel appearance upon being developed, that I deemed them worthy of exhibition, in the hopes that the mystery of their strange appearance might be explained.

Throughout the surface of the plates, there appeared ring-like spots, some not more than one-tenth of an inch in diameter, while others were about half an inch in diameter. These spots were nearly clear after development. At first I was inclined to attribute the defect to the developer, but the otherwise perfect character of the negative at once refuted any such theory. That the plates were perfectly prepared, is proved by the fact that some of them were tried previous to my departure, and were found to be free from blemish, and to work well. Also that one of them was exposed in Mazatlan, and developed on the same day, and was perfectly clear and clean. Some of those which remained undeveloped were placed in the hands of some of the members of the Society, and under their treatment pre-

sented the same appearance; in one case, rather more so, than those which were exhibited by me.

I have arrived at the conclusion that a decomposition of the coating of the plates takes place after exposure to light, and that when the development is delayed for too long a time, the decomposition will have progressed far enough to ruin the negative. The plates should, therefore, be developed as soon after exposure as can be conveniently done. The time that can be allowed to elapse between exposure and development, without deterioration of the plates, depends upon so many contingencies, such as power or force of light, quality and condition of plate and temperature, and dryness, &c., &c., that no fixed rule can be given for it; but I think that not more than ten to fourteen days should ever be allowed to elapse; although I have known plates kept successfully six weeks before development.

I have deduced the above conclusion from the facts, that the plates when first prepared and tried proved good; that the plate, which was exposed, and soon after developed in Mazatlan, also proved good; while those in which the development was delayed for a long time, were all spotted.

Two rules may be safely followed—in fact they *should* be, viz:—

1st. That the plates, when exposed in the camera, should be entirely free from moisture.

2nd. That after exposure no more time should elapse than is unavoidable previous to development.

I am apprehensive that the moisture of the climate may have dampened the plates at the time of exposure.

Why the decomposition should have taken this peculiar form, instead of pervading the entire surface of the plate, and what is its primary cause, are subjects I am now investigating, and should my experiments lead to anything conclusive, you shall have the results.

I shall leave for Mexico in a few days, and shall take a good supply of tannin plates with me, and shall watch this matter with very close attention. There is difficulty in the way, somewhere, and, if possible, I will ferret it out.

In the hope that these few hints may lead others in the right direction, and perhaps elicit an expression of their views upon this, so important a subject, I leave the matter with a promise to refer to it at my earliest opportunity.—*American Journal*.

ON COMPOSITION PHOTOGRAPHS.

WHEN will the world become wiser on the subject of photography? Perhaps of all arts the photographic has been the one most misunderstood, and the one on which the largest portion of ignorant criticism has been written. In its earlier days, portrait-painters took fright at the facility it possessed of affording a really truthful representation of life, and, fearing their own art would suffer, did all in their power to decry the latest-born of science, and abused it as a mechanical method of producing a map of the face, having no power of giving a life-like presentment of the human face divine. The beautiful results exhibited by our best professors have, in some measure, removed this erroneous impression from the mind of the public, and the press has tardily given way in this matter to the voice of the many; but it is still curious to notice the rabid manner in which some of the writers of criticism in the daily papers oppose the introduction of fine art into photography: they still speak of the camera as an unthinking machine, forgetting that the machine, as the brush of the painter, is guided by the will of the operator. As a specimen of this kind of criticism, one may mention the review of our present Exhibition by the *Daily News*. The writer says—"If there is a development of the photographic art more offensive than any other, it is that in which the aim is to make a subject-picture by 'arranging,' as the phrase is, so many properties and living lay figures as a picturesque composition. There is one particularly conceited attempt of this kind (166, 'Bringing Home the May') by

Mr. H. P. Robinson, to which a verse of Spenser is appended. It is a large photograph, with women and children dressed up in country clothes; but the May, intended to be as beautiful as the real flower, is a ridiculous-looking stuff, more like sponge than hawthorn-blossom." Any of our readers who have seen this elaborate composition, which occupied the thoughts of the artist for many months, will see the absurdity of the paragraph we have extracted. The latter part of it is particularly funny. We have good reason for knowing that the "May" photographed in the picture was *not* an artificial "property," as the writer evidently thought, but some of the finest in Warwickshire (a county celebrated for its hawthorn), gathered in an unusually good season.

But, after all, we must not expect too much from a writer of this kind—one who probably has not time to think, but allows his brain to become, like his own idea of a camera, a mere machine, and runs off his "copy" mechanically, to fill a certain amount of space. But it is different with a writer who professes to have an intimate knowledge of photography, and who has written on the subject for many years. In our last number we printed a paper read before the Photographic Society of Scotland (a Society distinguished for its appreciation of art-photography), by Mr. Sutton, in which he deliberately states, "The first chalk-drawings of a schoolboy upon a wall are, in my opinion, more admirable, from the human interest which they possess, than the finest view of inanimate natural objects upon the ground glass of a camera obscura."

This, we take it, is rank heresy. We are not writing with the object of confuting Mr. Sutton's strange expression of his taste. We think we should only be insulting the intelligence of our readers, did we point out and attempt to prove logically that a fine view, as seen in a camera is much more beautiful than a schoolboy's caricatures. Our object is to express our deep regret that the higher branches of our charming art should be so misunderstood and abused by a gentleman who has earned the respect and esteem of all photographers by his many valuable inventions for facilitating the practice of the art-science. Mr. Sutton confesses that his opinions often change; let us hope that they will experience yet one more variation in favour of the art he now writes so vigorously against, and that they will then remain permanent.—*Photographic Journal*.

THE APPLICATION OF PHOTOGRAPHY TO THE MAGIC LANTERN EDUCATIONALLY CONSIDERED.

BY SAMUEL HIGHLEY, F.G.S., &c.*

DISCUSSION.

Mr. CHARLES JONES, as an old member of the Society, expressed the deep interest he felt in the subject which had been so ably brought before them this evening, and the pleasure with which he had listened to Mr. Highley's paper; and he congratulated the meeting upon the very practical manner in which that gentleman had treated the subject. Since the year 1859, he (Mr. Jones) had devoted a great deal of attention to photography in connection with the lantern, and the members would probably recollect that on two occasions, at the Society's conversazioni, he had exhibited a series of photographic transparencies in the lantern, showing its capabilities as an educational instrument. Amongst other subjects of a popular character, he had recently photographed the engravings given in the *Illustrated London News*, representing various incidents connected with the distress in Lancashire, and he should feel obliged to Mr. Highley if he would be kind enough to include a few of those photographs in the illustrations with which he was about to favour the meeting.

Mr. HIGHLEY said he should be most happy to do so.

The CHAIRMAN then suggested that he thought it would be more convenient that the illustrations should now be shown,

and any further discussion upon the paper would take place afterwards.

Mr. HIGHLEY then exhibited, on a large screen, an extensive series of lantern views of scientific subjects, illustrative of the application of photography to the representation of geological, botanical, zoological, microscopical, astronomical, geographical, ethnological, biographical, and pathological subjects; and afterwards examples of the representations of the artistic works of Kaulbach, Schnorr, and Hogarth; together with groups of sculpture, as well as some specimens furnished by Mr. Charles Jones.

The CHAIRMAN said it was now his duty to recall the attention of the meeting to the subject which had been so ably brought forward in the paper, and to invite discussion upon it. After the illustrations they had just seen, he thought they would be better able to appreciate the paper which Mr. Highley had read.

Mr. PEARSALL thought the medical profession and society at large would be greatly benefited by the application of photography to the illustration of the various stages of the diseases of the human frame. He had frequently been called upon to make sketches of the progress of disease, but it was impossible for an artist to follow the rapid changes which sometimes took place in cases of a complicated character. In this respect, therefore, photography was of the greatest value. Its importance to the palæontologist was also manifested in the illustrations given of the restorations of extinct animals. With regard to the illustrations of the distress in Lancashire, he thought it was a remarkable proof of the perfection to which the art of wood engraving had been brought, that the subjects exhibited this evening bear the severe test of the high magnifying power to which they had been subjected in the lantern.

Mr. W. HAWES thought so interesting a paper as this ought not to pass over without a few more observations than had already been made upon it; for he thought very few would have had an idea of the importance of this subject in an educational point of view, had they not seen the illustrations which had been shown, and undoubtedly they would not have been in a position to discuss the merits of the paper, or to appreciate the views enunciated in it, without first seeing the illustrations by which it had been accompanied. When they considered that photography itself, as an art, was scarcely a dozen years old—that it was only just previous to the Exhibition of 1851 that it was first practically applied—it was a striking illustration of the marvellous rapidity with which knowledge of all kinds was made available, and how soon it became popular and was turned to really useful account. It was only by the untiring industry of comparatively few persons, who had devoted themselves to the study and development of this new art, that it could have been brought to such perfection as to allow of the production of such beautiful specimens as had been exhibited this evening. He thought their educational value could hardly be over estimated, and that those present were much indebted to Mr. Highley, not only for the paper itself, but for the illustrations of this beautiful art with which he had favoured them, and which showed the vast amount of benefit which would be derived from photography applied to educational purposes. He could not conceive anything more valuable to the lecturer and teacher than this power of reproducing the marvellous creations of Nature, and exhibiting them in the way they had seen this evening. He therefore hoped that they would unanimously thank Mr. Highley for bringing this subject before them.

The CHAIRMAN said, before they adjourned, he might be permitted in the name of the meeting, to thank Mr. Highley for the interesting paper he had read, as well as for the illustrations of it he had given. As an educationist, a line which he (the chairman) had himself taken, he could not thank him too highly for the manner in which he had brought the subject before them, connecting it, as he had done, immediately with education. The microscopic illustrations exhibited had shown, in a remarkable manner, how the valuable sources of information opened up to us by that instrument might be popularized, and rendered available for general instruction. As an educationist, he (the Chairman), would again thank Mr. Highley most heartily, for he thought they had arrived, happily, at the day when they did not regard education as a mere matter of form. The eye must be entertained, and they might in many ways contribute to education and enlarge the powers and faculties of the mind without treading merely those old and narrow paths to which education has been hitherto confined. The rule of thumb was no longer admissible as a simple means

* Concluded from page 105.

by which alone education could be conveyed; and any means by which science could be popularized was to every educationist, in 1863, the most valuable assistance that could be given. He therefore looked upon photography as a means, and a most important one, by which opportunity would be afforded of enlarging and educating the minds of the people. He now begged, in the name of the meeting, to thank Mr. Highley both for his paper and for his beautiful illustrations.

Mr. Highley exhibited some transparent and other stereoscopic views of Geological and other Natural History subjects.

COPPER-PLATE PRINTING BY PHOTOGRAPHY.

A DISCOVERY has been made by which copper plates for printing on a type press can be made by a photographic process. These plates are precisely the same in appearance as the stereotypes taken from wood-cuts, and are printed from them in the same manner. The process of making these plates is patented, and, without entering into intricate chemical details, is somewhat as follows:—The negative used is either taken photographically from the object to be represented, if an engraving or a pen-and-ink drawing, or it is drawn with a steel point upon a glass plate prepared for the purpose. These plates are perfectly white like porcelain, and, placed upon a dark ground, say a black cloth, every line made upon them appears black. Artists work upon these plates with the same facility as with a pencil upon Bristol board. The negative being ready, it is placed in the ordinary photographic printing frame, upon what is called a matrix plate, against a glass plate covered with a thin coating, hardly to be distinguished from the glass itself. This matrix plate is thus exposed to daylight under the negative, and when taken out presents a beautiful brown positive picture upon a straw-coloured ground. It is then immersed in fluid, and when again taken out forms a bold bas relief, the reverse of a wood-cut. To procure the plate itself in copper, it is only necessary to cover the matrix with a thin metallic coating, and attach it to the positive pole of a galvanic battery in the usual manner of making stereotypes from wax, plaster, or other molds. As soon as the deposit is sufficiently thick, the copper plate is separated from the matrix and backed with type metal, ready for printing. These plates, for illustrations of books, for pictorial papers, copies of engravings, &c., are produced at a price from 40 to 50 per cent. below that of wood-cuts. It is hardly to be estimated what revolution this invention will produce in the business of publishing and engraving, but it is supposed by those acquainted with the subject that, so far from injuring the engraving interest, it will benefit it by creating a larger demand for all kinds of pictorial illustrations, wherein every available talent will be employed. The American Phototype Company are now using this interesting discovery.—*Humphrey's Journal*.

Proceedings of Societies.

LONDON PHOTOGRAPHIC SOCIETY.

THE usual monthly meeting was held in King's College, on the evening of Tuesday, the 3rd inst., Mr. GLAISHER, F.R.S. in the chair.

THE SECRETARY having read the minutes of a previous meeting, the following gentlemen were elected members of the Society:—Messrs. W. Stokes, R. H. Allan, W. Cooke, G. J. Keet.

THE CHAIRMAN then called attention to various matters of interest to members, amongst which was a medal in wax of the reverse of the prize medal of the Society; some prints on paper prepared with india-rubber, by Mr. Cooper, possessing very pure and engraving-like blacks; some enlargements, we believe, by Mr. Warner, of Ross, and a couple of panoramic pictures taken on a flat plate with a common sixteen shillings lens, and including an angle of 120° with all the lines straight. The exact method was at present a secret, but would be published as soon as the patent was completed.

MR. SHADBOLT thought the Chairman was in error in sup-

posing all the lines straight, as those of the road were palpably curved. Nine months ago a gentleman showed him a positive picture which included an angle of 380°, going completely round the circle, and 20° over. He would bring the picture to the next meeting.

THE CHAIRMAN called attention to some circulars on the table announcing the forthcoming exhibition of the French Photographic Society, and remarked that he wished to reassure English photographers regarding the safety of any prints sent there, as some statements exciting distrust had gone forth. The names of the gentlemen constituting the Committee, and which were appended to the circular, afforded full assurance of the proper management of the exhibition.

THE CHAIRMAN then called attention to the handsome trunk camera which Mr. Meagher had given for sale in behalf of the Lancashire Fund, and which had not yet been sold. It was an excellent camera and a worthy object. There was another camera on the table of French manufacture, by Rollo, which possessed many advantages, and was very useful for copying.

THE CHAIRMAN next called attention to a curious illustration of the persistency with which an image sometimes remained on the plate, the outlines here being quite apparent after film was removed and the plate cleaned. It was in fact what might be called a spirit photograph. He also called attention to some card pictures which Mr. Wharton Simpson explained were the alleged spirit photographs produced in America.

A bottle of the double sulphate of ammonia and iron, prepared by Messrs. Horne and Thornthwaite, after the suggestion of M. Meynier, was examined.

THE CHAIRMAN announced that a portion of the presentation prints of the late Prince Consort, by Mr. Heath, were now ready and would be distributed by ballot. The remainder would be ready for distribution shortly, as Mr. Vernon Heath was printing them at the rate of about 50 per month.

MR. JOHNSTONE then read a paper "On the Electrical Theory of Photography."

THE CHAIRMAN, in proposing a vote of thanks to Mr. Johnstone, said he understood from the paper that Mr. Johnstone regarded chemical action as the visible exhibition of electrical action. It might be so, and it was possible the direct contrary was the case. Mr. Johnstone had, however, given considerable attention to the subject, and had very kindly come from Birmingham to explain his views, and he felt assured the meeting would willingly accord him its best thanks for his kindly feeling and earnestness in doing so.

MR. DEBENHAM then called the attention of the meeting to some experiments he had made with ammonia fumes upon excited albumenized paper—a subject to which he had given considerable attention. It was alleged that it would print in less time, and that the tones would be deeper and richer. In order to try it fairly he divided a piece of excited paper, and fuming one half, left the other as it was. He then placed the pieces side by side in the printing frame, under a double negative, both sides of which possessed equal intensity. This he had done repeatedly, preserving all the conditions as equal as possible, so that the effect of fuming might be distinctly marked. He had brought with him a negative and prints so produced for the examination of members. He had come to the conclusion that there was not the slightest advantage gained. At first, during the process of printing, the advantage seemed on the side of the fumed paper: it seemed to print with a deeper, warmer tone. But when both had been exposed for the same time, and both had been toned and fixed, he could scarcely distinguish the one from the other. Then there was a great disadvantage in the fact, that the paper would not keep, but discoloured considerably in the course of a single day.

MR. HUGHES, after making some observations on Mr. Johnstone's paper, and the importance of obtaining more certain knowledge of the principles upon which photogenic action was based, referred to the subject of ammonia fuming, and expressed his surprise that a good deal of space had recently been occupied in the journals discussing to whom the suggestion of fuming with ammonia was due, before it had been proved that the suggestion was worth following. It had been tried in his establishment without any advantage whatever, and had been voted by his people to be a useless bore.

MR. MALONE said the question of fuming was one purely of manipulation. The points to be settled were, what was the combination of ammonia with silver, and what were the effects of the combination in printing. These should be settled before discussing whether it was better to apply the ammonia by fuming, or by adding it

to the silver solution. When the ammonia-nitrate of solution, as proposed by Dr. Alfred Taylor, was used for plain paper, it was found to be more rapid, and give better results as regarded tone. As regarded the question of sensitiveness it was his conviction that it was decidedly more rapid than silver without ammonia. As to its value in regard to tone, since the introduction of gold toning that might possibly be altered, but with the old system it gave better tones. Then as to its mode of action, that was not well understood; and it was questionable whether the common theory expressed all that took place. It was quite possible that silver replaced a portion of the hydrogen as in cuprammonium copper replaced a portion of the hydrogen. In any case the subject demanded further experiment before it was condemned. He had recently tried the effect of a somewhat complex mixture consisting of ammonia added to solution of silver, and then nitric acid added until there was a faint acid reaction, and he liked the results better than with silver alone. He then proceeded to make some remarks on Mr. Johnstone's theory, observing that it was based upon conjecture only, and was not supported even by analogical facts. It was not, he thought, so well supported as the theory of the older chemists to the effect that the action of light was to split up the haloid salts of silver into their respective elements, forming chlorine, iodine, or bromine and metallic silver; and that in the case of a latent image that action was really commenced, though unseen, and was completed by the developer. This view was strongly corroborated by the experiment of Mr. Claudet in which he found that sufficient exposure of an iodized plate gave an image of metallic silver.

Mr. SHADBOLT asked if he rightly understood Mr. Malone to say that the action of light upon iodide of silver had produced a visible image without the presence of bromide or mercury?

Mr. MALONE.—Yes.

After a few words from Mr. Johnstone,

The CHAIRMAN said that Mr. Vernon Heath would read a paper at the next meeting "On the Progress of Photography in France."

The proceedings then terminated.

THE PHILADELPHIA PHOTOGRAPHIC SOCIETY.

THE second meeting of the Photographic Society of Philadelphia, was held at their new room in Walnut Street, and was quite crowded. The President, Mr. CONSTANT GUILLOU, presiding.

A portion of the time was devoted to the consideration of some amendments to the constitution, and to the election of new members, of which a long list had to be balloted for. Mr. Charles Waldack, of Belgium, and Mr. Robert Shriver, of Cumberland, Maryland, being elected corresponding members.

The report of the publication committee being acted upon, and there being no papers on scientific matter to be read,

Professor EMERSON said he wished to call the attention of the meeting to an article in one of the French journals, by M. Jacquemot, on the subject of the gradual fading of the impression of tannin plates, when their development had been delayed many days, and ascribing the cause to some molecular change in the film; he reviewed this theory, and also the theory advanced by Mr. Maxwell Lyte on the imprisonment in a thick film of the luminous impression. He stated that in his own experience there was no fading of the impression if the plates were protected from the action of the atmosphere; that in all cases of such fading he thought the truth should be ascribed to some atmospheric action on the plates, and that had they been kept from the air, they would have yielded good negatives even if months should intervene between the exposure and the development.

Mr. FASSITT had tried the experiment of exposing one-half of a plate one time, and then after the interval of a month exposing the other half—at the same time of day and with the same quality of light—and that the recent exposure developed better in every way than the other half, which was generally good in detail but lacking intensity.

Professor FAIRMAN ROGERS related his own failure in working the dry processes on very long journeys, but was doubtful as to the cause of his failure; but he would remark that he had never been so successful with tannin plates as he had been with malt.

The PRESIDENT spoke in high terms of the malt, and said that he had some malt plates at that time one year old.

Mr. FASSITT was sure nothing could work better than the

malt had in his hands, and he was often surprised at himself for having abandoned it for the tannin. He had just exposed a plate thirteen months old, and it was as good as when first prepared.

Professor ROGERS liked the malt for its simplicity; in his way of working he did not wash the plates after sensitizing, but merely drove off the entire silver by flowing the malt solution on and off.

Professor J. FRAZER said the water in our city after rains was in his opinion bad enough to cause all kinds of trouble, and the mud would be as bad as the dust would be. He recommended the use of filtered water.

Professor ROGERS agreed with him; but in his own case, he cleaned his water by subsidence in a large tank in the upper part of his house.

COLEMAN SELLERS had tried tannin plates washed when the water was not very clear, and he did not find any trouble from the mud. The water after rains being mere surface water is generally rather softer than when the rivers are clear, but low, and are supplied by springs. He begged leave to call the attention of the meeting, while on the subject of dry plate photography, to an experiment recently tried by Mr. Borda, who was not present to relate it himself.—

Mr. Borda had desired Mr. Hull, of New York, during his recent visit to this city, to expose two plates on the same view, one of which was to have his usual exposure, or such as his judgment should say it would require, and the other to have only thirty seconds. The first was exposed five minutes. This long exposed plate was to be developed on Mr. Hull's return home, hence we know not how it turned out. But the short exposed plate was treated by Mr. Borda in the manner suggested to him by Mr. H. T. Anthony, viz., toned with weak ammonia before development. He demonstrated on this plate that by careful manipulation and the use of a weak developer, little silver and considerable excess of the retarding acids to overcome the alkalinity of the film from the toning, the development would be protected for at least one hour and yet no tendency to fog, and his experiment resulted in a negative somewhat under-exposed it is true, but with a very intense sky and all the detail, excepting in the foreground well defined; one minute exposure would have given him a good picture. He had not done this to advocate short exposures, but to demonstrate the practicability of the toning process, and its advantages.

Professor ROGERS read a letter of inquiry as to the practicability of printing with the solar camera by artificial light.

Mr. WENDEROTH being appealed to, said he had made many such pictures, but all by development; and that an exposure of six minutes was needed in cases where he could have printed on the same paper in the same light by superposition in about one second. He had always preferred the developing process even for sunlight, but did not practise it now owing to the difficulty of instructing others how to work, and the work attending careless manipulation.

During the evening Professor Emerson exhibited some of Mr. C. Breeze's glass stereographs, which he had brought with him from England. They were greatly admired.

Vice-President SERGEANT exhibited a specimen of resin paper printing, from England, which may not have been a fair specimen, but was not considered of any value at all.

M. LA FETE exhibited his Jaminiscope, and, much to the admiration of the members, explained its *modus operandi*.

COLEMAN SELLERS displayed two sizes of the Harrison and Schmitzer globe lens, and exhibited specimens of work done by them; also in contrast a specimen of the work of the Grubb aplanatic lens, which is said to include a visual angle of seventy degrees, but with considerable spherical distortion of the marginal lines, as was evident in the print shown.

Professor EMERSON presented the Society with one of his stereoscopes, and received the thanks of the Society for the gift.

It was resolved that the room should be open every Wednesday evening, for informal conversational meetings.

The meeting then adjourned; but the members were so interested in general conversation, and there seemed so much harmony and good feeling among all present, that it was late before they retired, all well pleased with the beginning of the infant society.—*American Journal*.

Correspondence.

IODIDES AND BROMIDES IN COLLODION.

DEAR SIR,—The leading article of your issue of the 24th October last somewhat alarms me; but, I really hope you do not mean to close the discussion.

I am aware that I need expect no mercy, for I am contesting a widely received principle, and, thereby, placing myself in direct antagonism to a large section of photographers. But I believe that you will give me one more opportunity to be heard, because of "the earnestness and manifest honesty" which you have handsomely attributed to my exposition of the question of "iodides and bromo-iodides." Your claim "to do full justice to all sides of all photographic questions" cannot be disputed, and its enunciation, particularly, makes me bold to avail well of the opportunity you will now finally afford me of defending myself from misconception on the one hand, and of pointing out error on the other.

You pronounce my first error as having "misappreciated the avowed character of Mr. Blanchard's experiments," and explained that those experiments were held "tolerably conclusive of the fact, that bromides and iodides, in combination, were more sensitive than either bromides or iodides alone."

I was well aware of this, provided, that by "iodides alone" is meant ammonium, or potassium, or magnesium, and no other; for, at page 479 of the PHOTOGRAPHIC NEWS, I remarked as follows:—"They (Mr. Blanchard's experiments) were simply illustrative of the circumstance, that, under certain conditions, which nobody should adopt, bromo-iodized collodion is superior under iron development to simply iodized collodion."

You also remark, that, on the "general question," Mr. Blanchard's experiments were not put forth as conclusive." No admission could be franker or fairer, and I am sorry for having understood otherwise.

The "general question" (the exposition of which has never yet been attempted) I have endeavoured to show, involves the arranging against each other of an iodizer and bromo-iodizer made of one collodion, and constructed of like salts, and like combinations, *i.e.*, if the iodizer is compounded of ammonium and cadmium, or cadmium and potassium, the bromo-iodizer should also be made of the same salts, in the same proportion; only, that a part or all of one of the salts in the latter case should be a bromide; and that, if the iodizer is made only of ammonium or only potassium, or only cadmium, that the corresponding bromo-iodizer should be made of iodide and bromide of ammonium, or iodide and bromide of potassium, or iodide and bromide of cadmium, when, a comparison will show the iodizers invariably superior in every respect to their pair bromo-iodizer.

It is possible, nay, certain, that in the several combinations of cadmium and ammonium, or cadmium and potassium tested, that the bromo-iodizer of one experiment or pair will be superior to the iodizer of another pair; but this bromo-iodizer will in its turn be inferior to its pair iodizer. We can evidently, then, make iodizers and bromo-iodizers of various capacities (the cadmium being the regulator of durability and sensitiveness) alternately inferior and superior, until we come to an iodizer superior to the best bromo-iodizer, which will be at the same time the pair of that iodizer, and superior to all other iodizers and bromo-iodizers. And, above all, the pure cadmium iodizer will rank first. I have nowhere taken ammonium or potassium iodizers into account, because, for practical purposes, they can bear no comparison with the combination salts. I have shown the results of my experiments in a letter dated and posted a month ago to your address, under the head A to D, as also the comparative merits of pyro and iron development. An examination of the same will show that iron development stands first.

To show that the combinations of salts do possess the different degrees of sensitiveness and durability that I claim for them, I will place the matter in the following light.

Very sensitive ammonium and potassium collodion can be made. They are undisputable facts; for instantaneous work has been done with them, as with cadmium collodion, or with collodion salted with combinations of salts. But they (the potassium and ammonium iodizers) are so capricious as to render them a source of trouble. Hence cadmium collodion ranks first on the score of stability. Next to it we must place combinations of cadmium and ammonium, or cadmium and potassium, their order being regulated by the proportion of the

cadmium salt present in each, until we end with ammonium or potassium only. Now, all are equally sensitive.

But, for all practical purposes, how do matters stand? We cannot avail ourselves of each in its best condition; we cannot at will give to each the collodion most suitable to it; but we may at all times succeed in getting a collodion fit to be iodized with one or more of the combinations, and we can never better employ a collodion. Any collodion fit to be iodized, with potassium or ammonium alone, will admit of the introduction of cadmium more or less. Any collodion fit to be iodized with cadmium only will admit of any combinations of salts (which anybody may ascertain for himself in a moment) being used with it, although it will be worthless for ammonium or potassium alone. Any such collodion will therefore be the best to experiment with.

Now, cadmium glutinises collodion and attains maximum sensitiveness slowly, and it deteriorates slowly; but potassium and ammonium liquefy collodion—they attain sensitiveness quickly, and as rapidly lose it. Under these circumstances the effects of the alkaline salts upon the collodion are not so energetically injurious in the presence of cadmium as when employed alone; but injurious they still are in proportion to the quantity, and are comparatively innocuous when their quantity is small. I should therefore conclude that the smaller the proportion of the alkaline salts, and the greater that of cadmium, the less the injury to the collodion by the greater glutinosity opposed to the liquefaction: the greater the stability by the resistance to the deteriorating effects upon the collodion, and the superior the ultimate sensitiveness by the time given to attain it.

Only on one supposition, it appears to me, could there be an equality of sensitiveness in all combinations with any given collodion—if the alkaline and acid salts, apart from the question of stability, sensitize the collodion equally rapidly, and affect it identically; but this can never be the case.

As respects Mr. Blanchard's experiment with iodide of potassium on the one hand, and a bromo-iodized collodion on the other, made to test whether a potassium iodizer was the most sensitive, as claimed by some operators, I beg to observe that under no circumstances could the result be reliable, unless the comparative experiments (provided that the collodions and baths most suitable to the salts had been furnished) had been extended over a period such as would have included the best average condition of such collodion, as insisted upon in my last letter.

As regards equality of sensitiveness between all iodizers, I think there should be very little room for doubt if the exact condition of suitability of collodion and availability in the exact stage of sensitiveness—especially as regards potassium or ammonium collodion—are secured. For we read of instantaneous work by Count Montizon, Legray, Maxwell Lyte, &c., with the ammonium and potassium salts. No operator now, however, would so use them because of their notorious capriciousness and instability, and all prefer collodion salted with cadmium, or at least as half of the total quantity of salts, because stable and comparatively reliable.

As respects the exception I have taken to Mr. Blanchard's experimenting with one plate, two collodions, and two lenses, which you have thoroughly explained, I scarcely care to wish it to be decided (more emphatically than it has been done by you) whether the plan I recommend or Mr. Blanchard's is the legitimate one, and which of them is to be recommended for simplicity, and, above all, for unquestionable accuracy and certainty of result. For you already concur with me in the use of one lens, and, by implication, one plate and one collodion.

I think you agree with me that one collodion, iodized and bromo-iodized similarly, one lens, and light exposure are indispensable. I claim also one bath for each pair of iodizers and bromo-iodizers, but you contend that "a bromo-iodized collodion, for instance, works best with nitric acid in the bath; to a simply iodized collodion this would be fatal." To prevent the possibility of any misapprehension of terms here, I beg to inquire whether by "simply iodized collodion" you mean a collodion iodized only with potassium, or ammonium, or magnesium, or with cadmium and combinations including cadmium. If with the first three salts, I concur in part with you; but if with cadmium and combinations including it, I differ most emphatically from you.

All my experiments were made with nitric acid baths only; and in page 467 of the PHOTOGRAPHIC NEWS I laid down the following as a radical principle:—"The constitution of the

nitrate bath is no unimportant matter in experiments—one abound with acetate of silver and alcohol, &c., is the least desirable. The only one admissible is a pure, unadulterated bath, having had a little careful working. As the question of fused and recrystallized nitrate of silver is still in an unsatisfactory condition, the best salt from reputable dealers will answer; and as regards organic matter in water, let the liquid be cleared by light and oxide, and we shall have a good stable working bath, rectified with nitric acid and oxide.* And lower down, in the same letter, I have again alluded to the nitric acid bath. No where have I made mention of any other bath. Nothing can be plainer than this, and than the principles I have contained for in comparative experiments.

I am not the first to consider a nitric acid bath anything but fatal to iodized collodion. Mr. Thomas, of Pall Mall, years ago enunciated the superiority of the nitric acid bath over every other, and he made no distinction between any iodized and bromo-iodized collodion. To this day his collodion bottles have printed wrappers describing the construction of his normal bath. Another able advocate for nitric acid baths is Mr. Hockin. *Vide his Photographic Treatise.*

My experience of the several baths is as follows; and it is in the power of anybody to satisfy himself of its thorough correctness.

A nitric acid bath answers the best with cadmium collodion, or collodion containing cadmium as one of the salts. But the bath must wait for the ripening of the collodion, whether iodized or bromo-iodized, when it will give exquisite negatives free from spots and stains; but not more rapid results than those attainable with the same collodion in acetic acid, acetate of soda, or carbonate of soda baths, when these are in their sensitive condition. But the nitric acid bath is supreme in stability, *i.e.*, it is rectifiable and comparatively under control. It deteriorates slowly.

I do not, however, concur in the use of the nitric acid bath with ammonium and potassium collodions, newly iodized and bromo-iodized with those salts, or in their sensitive conditions. The other baths will then give by far the better negative. When, however, the said collodion is deteriorating, the nitric acid bath will give a finer detailed negative, and in a shorter time.*

THE FRENCH PHOTOGRAPHIC EXHIBITION.

SIR,—My attention has just been directed to a letter in the *Photographic News* of the 13th February, which contains a charge against the French Photographic Society, or rather against its secretary, to which the approach of the exhibition at Paris gives special importance.

I am confident, that, as a gentleman, Mr. Vernon Heath will, after reading the explanation, experience a regret equal to my astonishment, and he will admit, that if we had had the good fortune as to speak the same language and to do without the aid of an interpreter, we should have both been spared a very disagreeable affair. In fact, if I had not waited for his return, he would have received at once the explanation to which I am now obliged to give the publicity he has given to his note.

When last month Mr. Vernon Heath did me the honour to visit me at the French Society's establishment, with the gentlemen he had been so fortunate as to meet at Paris, he had, I was informed, two objects: first, the wish to present some specimens to the Society at their next meeting, and next, to reclaim some frames sent by him to the Exhibition of 1861. I gave to the first proposition, naturally, the flattering reception that it merited, and recollecting the frames exhibited by Mr. Vernon Heath in 1861, I said that if they had not been sent back at the close of the exhibition they had certainly been kept carefully at the *Palais de l'Industrie*, whether by error or for some other reason, which it was not possible, after the lapse of two years, for me to recollect at once; I promised, however, to go myself and see to the matter.

The following day, I believe Mr. Vernon Heath came again with the same gentleman to say that he was obliged to leave sooner than he expected, and could not be present at the meeting of the Society. Being much occupied by

business rendered urgent by my long absence in London for the exhibition, and not thinking that the departure of Mr. Heath would have been so precipitate, I had not gone to the *Palais d'Industrie* to make inquiries. I said I would go the same day, and did not doubt to find the frames if they had not been sent, and I could easily after his departure send them to London or elsewhere. I proposed at the same time to make in his name, the presentation, he regretted not being able to make himself.

The answer returned to me was, that this would be useless, as Mr. V. Heath's absence would be very short, and on his return he would certainly call on me.

The day after, I went myself to the *Palais d'Industrie*, and found that, in fact, the frames of Mr. Vernon Heath were placed with care among others for which, for their despatch, orders had not been received, or for which we had received contrary orders.

Mr. Vernon Heath, in his note, admits that I had informed him of the prolongation of the Exhibition, and asked him if he wished his frames at once, or with the others sent by France to the International Exhibition. He admits, also, telling me not to send them, as he had an agent at Paris. Now, did Mr. Vernon Heath, or did he not, give the order to his agent to fetch the frames, or were the frames to be sent to his agent? I cannot affirm positively, but, in either case, there could be nothing worse than a simple error.

Having understood seriously the answer that was made me, I waited innocently his return to give him these explanations.

As regards Mr. Robinson, the answer is still more peremptory.

When Mr. Vernon Heath and his friend spoke of Mr. Robinson's reclamation, and assured me that he had sent at the same time as Mr. Heath some photographs for the Exhibition of 1861, I answered that I did not recollect, and that he was probably mistaken. I recollect very well certain subjects and studies after nature, of which Mr. Robinson was the author, and which had figured in former exhibitions, but that he had not since exhibited at Paris. Despite the assertions to the contrary I find that I was right, for the catalogue of 1861 does not mention Mr. Robinson, but that of 1859 does mention him. Notwithstanding the time that has elapsed, I succeeded in getting traces of this affair, and here is what passed in 1859 on the subject of Mr. Robinson.

To be agreeable I put him in communication with a gentleman engaged especially in the sale of photographs. I knew nothing of him personally, but I had heard of Mr. Rarrere, 59, Rue Richelieu, and to him I mentioned the matter. He wrote to Mr. Robinson to send him direct the prices of his photographs. I had no reason to take further steps which might appear officious, so delivered to Mr. Rarrere the photographs of Mr. Robinson on his account, with the exception of two that were to be left with the Society as specimens. It is then to Mr. Rarrere that he should address himself, for it is no longer an affair of exhibition, but of commerce, to which, thank goodness, I am entirely a stranger. If there is negligence, Mr. Robinson has only himself to blame.

You see, Mr. Editor, how an uncharitable interpretation can alter and distort the most simple facts. I believed it right to enter into these details because, I repeat it, the circumstances give particular importance to a charge calculated to deter your countrymen from exhibiting at Paris.

The French Society, which counts amongst its members a great many foreigners of every country, has always shown in its actions the most liberal intentions, and has always shown and proved its good sentiments towards the Photographic Society of London.

As for me, its Secretary, I have certainly not the pretension to be perfect and infallible, nor yet to satisfy everyone, but I certainly do my best, so that the number of those who render me justice is sufficient to compensate for the annoy-

* The remainder of Mr. Webb's letter in our next.

ances entailed by my position. Anyone who has seen our exhibitions must admit that we have for the foreign exhibitors a care that our French exhibitors would be glad always to meet abroad.

To assure your countrymen, I can inform them that some of the best English photographers at the International Exhibition wished to exhibit in the French section for the only reason that they could depend upon my care and attention.

At the close of the International Exhibition, my honourable colleague, Dr. Diamond, Secretary of the London Society, informed me rather late of the special exhibition then contemplated and now or lately open. I thereupon gave orders to stop at once all packing, and took the necessary steps among the French exhibitors, notwithstanding the derangement and trouble both for them and myself. If through being informed too late the result was not so complete and perfect as I should have desired, at least I did all that was possible.

Now, sir, shall we be wrong in counting upon a just reciprocity? I do not believe so. Sir, I hope that this answer, published in your journal, will suffice to change the consequences of a charge which, I regret, I did not see earlier. I am persuaded the London Society will act as we would act under similar circumstances, and, with yourself, will do us justice. No, sir, I do not doubt it, for I have met amongst your countrymen many true gentlemen, and have considered the meeting to be simply natural and not an unusual piece of good fortune.

I count, sir, upon your honour for the prompt insertion of this answer, and beg you to receive the expression of my distinguished consideration.

M. LAURIER.

Secrétaire-Agent de la Société Française de Photographie, Rue Drouot, 11, Paris.

P.S.—Mr. Vernon Heath having an agent at Paris, ought to find it very simple and just that we expect him to send and take his frames, and I insist above all that he sees them in their actual state and admit that we take for our exhibitors precautions that are not always taken elsewhere.

The International Exhibition.

REPORT OF THE JURY ON PHOTOGRAPHY AND PHOTOGRAPHIC APPARATUS.*

3100 HORNE and THORNTWHAITE (H.M.) contribute a variety of cameras and lenses well adapted for general use.

Powell's registered stereoscopic camera, possessing the utmost degree of portability combined with efficiency. Schaw's camera is also well-suited for tourists: an instantaneous shutter on the principle of the guillotine is very ingenious and well adapted for its purpose. Various other articles are exhibited, all of which are characterized by general excellence. The chemical contributions are fine, and the specimen of chloride of gold is probably the finest in the Exhibition.

3111 LEAKE, J. C. (H.M.), is the inventor of a convenient and portable dark tent of very moderate price and considerable efficiency. The principle is simple and good, but the example exhibited had not been made with sufficient consideration to the temperature to which it would be exposed, being considerably warped and twisted by the heat.

3120 McLEAN, MELCHISH, and HAES (H.M.).—A variety of apparatus of general excellence is exhibited. Portable cameras made of metal for combining perfect rigidity with lightness and portability; Lieut.-Col. Shakspeare's simultaneous camera, in which an extra lens is attached to act as a finder, so that when a proper focus has been obtained by this lens, whilst the sensitive plate is *in situ*, exposure may follow immediately after, without the delay which is usual where the ground glass has to be withdrawn and the holder containing the sensitive plate inserted in its place.

A variety of lenses combining facilities for lengthening and shortening the focus, to render them suitable for landscape as well as portraiture, are also exhibited.

3128 MURRAY and HEATH (H.M.)—This firm, which has lately passed into the hands of Mr. Heisch, chemical lecturer at the Middlesex Hospital, exhibits apparatus of great excellence. A copying camera, with a variety of convenient appliances, and capital workmanship and material; camera-stands of bamboo cane, combining great height with lightness; a chemical chest, or portable laboratory, with complete equipment for use; Smart's dark tent, which affords considerable convenience as a portable dark room, is so fitted and arranged as to secure every facility for operators engaged in landscape photography; other apparatus exhibited by this firm combine all modern improvements in design with great care in the goodness of the workmanship.

3125* MEAGNER, P., (H.M.) exhibits a variety of cameras, camera-stands,

stereoscopes, &c., of very great excellence in design, material, and construction. The seasoning of the material is stated to have received especial care; the skill shown in the contrivances for the convenience of the photographer, and the workmanship and general finish possess much excellence. In addition to other modern cameras, Mr. Meagher exhibits a tourist's camera intended for stereoscopic pictures, or for plates 7 inches by 5; the body is of the bellows form, expanding from 3½ to 10 inches, being applicable for the short focus of quick-acting stereoscopic lenses or the Dallmeyer's triplet. Six dark frames accompany the camera, and the focussing-glass is attached—a great convenience in out-door operations. It is altogether a most convenient, economical, and portable instrument, very well adapted for the combined purposes for which it is intended.

Mr. Meagher is the manufacturer of the excellent cameras originally designed by Mr. Kinnear of Edinburgh; he manufactures largely for the dealers in first-class apparatus.

3129 NEGRETTI and ZAMBRA (Medal) exhibit a variety of photographic camera and stereoscopes of very great beauty in design and neatness of workmanship. In stereoscopes their specimens display great variety and elegance. The revolving stereoscope, exhibiting many slides in succession, is a very desirable application; other apparatus are also contributed by this firm. Reference will be made elsewhere to their beautiful transparencies and book illustrations.

3133 OTTEWILL, T., and CO. (H.M.).—This firm send samples of their well-manufactured cameras, consisting of folding cameras, trunk cameras for the operating-room, binocular and other stereoscopic cameras, together with many other useful photographic appliances.

3136 PONTING, T. C. (Medal).—A medal was awarded to this exhibitor for the excellence of his sensitive collodion, a reference to which has been made in speaking of Bland and Co., who exhibit samples of his manufacture.

3149 ROSS, T. (Medal).—A medal was awarded to Mr. Ross for the excellence of his photographic lenses. These include a variety of forms for different purposes, all of which are of very good quality. The portrait lenses comprise various examples, possessing great intensity, good definition, and great rapidity, yielding negatives of considerable beauty, prints from which are exhibited. The single landscape lenses are unsurpassed of their kind. A stereographic double combination is very rapid, and well suited for taking instantaneous views. The orthographic lens, constructed on the formula of Professor Petzval, is well adapted for the delineation of architectural subjects and for copying flat surfaces; all these lenses have their chemical and visual foci coincident, and on trial proved highly satisfactory, fully maintaining the reputation of a house which in 1851 received the only award for lenses especially manufactured for photographic purposes. The chief novelty manufactured and exhibited by Mr. Ross is a panoramic lens and camera, invented by a gentleman who has contributed many ingenious novelties to the art. It is novel in principle and results, giving pictures which include a lateral angle exceeding 100 degrees. Mr. Ross also contributes examples of a great variety of excellent apparatus in which the form and workmanship are of first-rate quality; they combine all the most approved appliances known and used in the art.

3150 ROUCH, W. W.—This exhibitor sends a series of valuable apparatus and chemicals.

A portable operating chamber, described as Edwards's New Model Tent, combining great portability with convenience and efficiency, differing in many of the contrivances of a similar character in the ample room afforded in the part immediately over the head of the manipulator, materially contributing to his comfort. Another well adapted portion consists of a small water-tank placed outside, a pipe from which, with spring tap, enters the tent at a convenient corner, being always at hand for the ready use of the operator. The tent is in every respect admirably contrived to meet the wants of the amateur photographer. Various cameras are also exhibited. A well-contrived portable laboratory; an instantaneous shutter; dippers for the bath of pure silver; and other photographic requisites. Mr. Rouch also contributes samples of bromo-iodized and other collodions made according to Mr. Hardwick's formula. A medal was awarded to Mr. Rouch for his series of small photographs, which are stated to be produced in the tent referred to, and with the same kind of collodion and chemicals he exhibits.

3155 SKAIFE, T. (H.M.).—Mr. Skaife is the inventor of an ingenious miniature camera described as a "pistolgraph," the productions of which he terms pistolgrams. The lenses are very small and exceedingly rapid, and well fitted to the production of very small instantaneous pictures, to which aid a clever instantaneous shutter is attached. The pictures are glass positives sealed between two pieces of glass, which are then ground by the lapidary, and fitted into mounts for various purposes. The representations are generally those of babies, and every phase of infatuate expression is accurately depicted by the means that Mr. Skaife uses.

3158 SOLOMON, J. (H.M.), exhibits, in addition to a good general display of apparatus, a great variety of excellent contrivances for the aid of the photographer, amongst which may be mentioned a cutting table on which to trim and shape photographs. It consists of a slab of thick plate glass, fitted on a frame, and moving on a centre; the glass slab revolves whilst the photograph and glass shape remain unmoved, which facilitates the operation and prevents the slipping or disturbance of the shape. Also a strong iron camera stand of great utility in the process of development; a new pneumatic holder; a collodion pourer which prevents the possibility of impurities ever falling on the plate; a dropping bottle on a good principle; a convenient dark tent, and a variety of other appliances; the whole showing considerable ingenuity and well deserving of attention.

3161 SPENCER, J. A.—Various samples of albumenized photographic paper. These papers are carefully prepared and salted in different proportions, to suit the purposes for which they are especially intended. Mr. Spencer manufactures very extensively for some of the leading firms in this country.

3157 WRIGHT, DR. H. G. (H.M.).—The complete portable apparatus combining a dark tent and all requisites for operating in the room or open air, which pack into a parcel easily carried by one person, was invented by Dr. Wright, a physician in extensive metropolitan practice, with a view to the facility with which it might be carried into the sick room and assist in the delineation of the various aspects of disease. It is equally well adapted to the purposes of landscape and stereoscopic photography. It is altogether a skilful and valuable contrivance.

AUSTRIA.

671 DIETZLER, C. (Medal).

679 VOIGTLANDER and SON (Medal).—These two names may with great propriety be associated, both having received Medals for the excellence of

* Continued from p. 106.

their lenses, and both basing their construction on the calculations of Professor Petzval. The lenses of Voigtländer are characterized in a remarkable degree by intensity and perfect definition on a mathematical plane. The lenses of these makers combine qualities which render them eminently valuable to the photographer.

— PONTI, CHARLES (Medal).—A Medal was awarded for a novel instrument styled the "alethoscope," invented by this exhibitor, by which very remarkable effects of relief and illumination are obtained. This instrument was only introduced into the Exhibition a few days before the Jurors closed their labours; they are enabled, however, to state that it will doubtless afford a new source of interest in the application of photographic pictures, and with a new object to amateurs in the art.

128 MOLL, A. (H. M.), displays a remarkably fine series of photographic chemicals, showing that much care has been used in their preparation, appearing to the jury well worthy of commendation.

(To be continued.)

Photographic Notes and Queries.

CRYSTALLINE DEPOSIT ON NEGATIVES.

DEAR SIR,—Having noticed an article in No. 223 of the PHOTOGRAPHIC NEWS respecting the crystalline deposit on negatives, and having myself occasionally been disappointed in taking views of any beauty whatever from that cause, I am induced to make the present communication to you on the subject, as my experience slightly varies from what I find stated in that article.

The size of plate I usually work is 10 by 8 (that being the most convenient size for India, where the thermometer is frequently over 100° in your dark tent), with a bath (glass, in mahogany case) containing about 50 or 60 ounces of bath solution; collodion, Bolton's and Thomas' mixed. With these I have taken as many as twelve negatives in one day, and that without a single failure; but a short time ago, wanting to take a view, and not having any collodion on hand but what had been either very recently or several weeks previously iodized, I chose the latter and went out. The first picture, however, that I took on fixing had a peculiar greenish appearance, and was slightly fogged, and when finished, looked as though it were covered with pin-holes; this rather puzzled me, but remembering that I had left the plate in the bath rather longer than usual (about 3½ minutes), and, thinking it might have resulted from that, I coated a fresh plate, only giving it one minute in the bath, and the result was that I got as good a negative as any I have yet taken; not understanding this, I tried again, leaving the plate in three minutes, when the negative, on finishing, presented the same defects as the first one did, and I found that I could, by changing the time for sensitizing the plate get either a good or bad picture with that collodion. Being struck with this peculiarity, I tried the next day again with similar results; but on using some new collodion, I found I could not affect it in that way, for no matter how long I left it, even to ten minutes, in the bath, the film was even and firm and perfectly satisfactory.

Now, I don't think this could have arisen from the supersaturation of the bath with iodide of silver, because the bath is nearly new, and the temperature never falls sufficiently low to cause it to crystallize; besides, it only affected the *old* collodion when left in the bath longer than usual. If it is owing to the collodion, how is it that it works well when only left a short time in the bath?

The only conclusion I could come to was that the pin-holes were caused by keeping the *old* collodion too long in the bath; but whether the fault was in the collodion or the bath I am unable to say, but should very much like to know if any person of more experience and knowledge than myself would kindly inform me.

Regretting that I have transgressed so much on your time and patience, believe me, yours faithfully,

AN ENQUIRER.

Court House, Bombay, January 26th, 1863.

[In the number of the PHOTOGRAPHIC NEWS to which our correspondent refers, there are two articles on the subject: one by Mr. Waldack, in which he refers the deposit to iodo-nitrate of silver; and one by ourselves, in which we trace it on some occasions to a different cause, namely, the formation of oxalate of silver. If our correspondent will read that article he will find that it is to the use of an old and somewhat decomposed collodion we refer this result. Leaving a plate long in the bath would, of course, give more time for its formation.—ED.]

ALKALINE TEST PAPER.

SIR,—It has occurred to me as an omission in many manuals of photography, and in the lists of "requisites" published by photographic chemists, that although litmus paper is given as a test for acids, no test is mentioned for alkali.

For this reason I think it probable that many operators may not be aware of a fact well known to chemists, viz., that a paper made from turmeric will detect the slightest trace of free alkali with as much certainty as litmus will detect acid.

A teaspoonful of turmeric should be boiled for a few minutes in half a pint of water; and when the decoction has been allowed a short time to settle, white blotting-paper should be soaked therein and hung up to dry. The paper will be dyed a bright yellow, which will instantly change to a red brown under the action of alkali.

A gold toning bath which would cause no alteration in the colour of either test paper (litmus or turmeric), would thus be perfectly neutral.

As there are many who would be glad to know of such a simple test, the above may perhaps be worth insertion. If you do not think so, pray put it in the waste basket, and oblige—Yours obediently,

W. CORRI.

East Greenwich, March 3, 1863.

[The use of turmeric paper is so familiar in chemical experiments, that it may probably have escaped especial mention, and is worth mentioning for the benefit of beginners, who will generally, however, find it better to use the reddened litmus for the purpose.—ED.]

AMATEUR PORTRAITURE IN THE OPEN AIR.

DEAR SIR,—I have the pleasure to send a few cartes de visite portraits for your inspection, being the result of following out the directions given in the NEWS and the NEWS ALMANAC, and showing what kind of portraits may be taken in the open air. They were done in the country the week before last, when the frost was on the ground. Perhaps a description of the way in which they were taken may be useful, as some amateurs are apt to imagine that portraits can not be produced except in the studio.

The sitters were placed against the garden wall, with a piece of canvas nailed against it for a background for full length picture; a piece of coloured calico was nailed on one side of the background for a curtain, and a bit of carpet placed on the ground, a chair and table completed the accessories. The plates were prepared and developed in a Smart's tent set up in the garden. The lens used was Dallmeyer's No. 1 B lens with the X stop for vignettes and the next size smaller for full length pictures. The collodion was made with pyroxyline according to the formula in the NEWS ALMANAC. Ether and alcohol methylated, a 50 grain nitrate bath slightly acid with nitric acid; developer, iron, 30 grains; acetic acid, 15 minims; water 1 ounce; alcohol, 20 minims; intensified with pyro, 2 grains; citric acid, 1 grain; water, 1 ounce; fixed with cyanide, 8 grains to the ounce of water.

I am sorry that printing is not better, but it was done away from home, and, therefore, rather carelessly. They were toned in Lacy's bath as given in the ALMANAC.—I remain, dear Sir, yours faithfully,

N. L. NOVERRE.

[The portraits received form a very interesting illustration of what may be done by the amateur with a little judgment and contrivance, without the manifold appliances of the professional portraitist; some of the specimens surpassing those produced "with all appliances and means to boot."—ED.]

THE GAROTTERS.—Mr. Rolfe has just produced a card picture illustrating the *modus operandi* of garotting. The "nasty man," as the operating garotter is technically named in the "profession," is just putting on the hug; while the "front stall," whose duty it is to secure the plunder, with one hand seizes the victim's watch and aims a blow with a bludgeon held in his other hand. The background is too light, and does not represent night, but the action is very well managed. The illustration is a little late in the market: with returning spring the public have almost forgotten that garotters exist.

Talk in the Studio.

DOUBLE SULPHATE OF IRON AND AMMONIA.—This double salt recently recommended by M. Meynier as a developer in preference to the ordinary protosulphate of iron has been manufactured by Messrs. Horne and Thornthwaite. We find on trial that it has certain advantages. Using a 25-grain solution with 25 minims of acetic acid it gave very good results. The action was very regular and perfectly under control, giving greater density and clearer shadows than a similar solution of the usual protosulphate. This is what we anticipated, as the general presence of a large portion of sulphuric acid in the common protosulphate of iron tends to the production of a thin grey image, with slightly veiled shadows, and this in the double salt is avoided. M. Davanne expresses a conviction that with this latter the molecules are thrown down in a much finer state of subdivision than with the ordinary developer, thus securing a more delicate image. The double salt is also more stable, having less tendency to peroxidation.

PAISLEY PHOTOGRAPHIC SOCIETY.—We are glad to see from a local paper that a photographic society is in active operation in Paisley. A meeting was held on Thursday evening week, Mr. Robert Harris, Vice President, in the chair. The subject of the evening was recent improvements in toning processes. Amongst other things exhibited was a very beautiful print, taken from a negative photographed by Mr. Edmonds, from Mr. Stewart's fine painting of "Interrupted Studies," at present in the Edinburgh Exhibition, and Mr. Archibald Barr also exhibited some fine prints on the newly introduced tinted paper. Mr. John Clark, Gateside, presented to the society's library a handsome bound volume of the PHOTOGRAPHIC NEWS for 1862, in consideration of which, and also of the many valuable donations he has repeatedly presented to the society, they awarded him a cordial vote of thanks, and instructed the Secretary to transmit him the same. A vote of thanks to the Chairman terminated the proceedings.

AMMONIA DEVELOPMENT.—Speaking of the ammonia development, Major Russell says:—"In certainty, this method, as I now manage it, leaves nothing to be desired, and there seems to be less liability to stains, or spots, than in the acid method. The only points which I have lately found out are, that commercial carbonate of ammonia is a little better than the solution of ammonia, and that the best proportion is 1 grain to 1½ grain of the carbonate to 1 grain of pyrogallie, to be used in from 2 drachms to 1 ounce of mixed developer. Within these limits there is little difference in the effect; the stronger the developer the quicker its action, but the weaker the more entirely free from all veiling will be the negative: the amount of detail brought out does not seem to be affected by the degree of dilution within the limits mentioned. The best way is to pour the ammonia, dissolved in equal parts of alcohol and water, over the dry plate, then to mix the pyrogallie, and pour on again." A new edition of Major Russell's little work, "On the Tannin Process," will shortly be published. We have just received an interesting letter from Mr. Leahy, on the development of dry plates, in which he says lime-water will develop tannin negatives. The letter in our next.

To Correspondents.

A. LEWIS.—Your "spirit photograph" is much more spiritual looking than the alleged genuine pictures produced in America, which are very clumsily managed. The ghostly effect in your attempt is very well managed.

BROMIDE.—The arrangement of canopy or screens in taking portraits in the open air must depend largely on circumstances. The canopy may be made of the slate-coloured glazed calico to which you refer; the extent to which it should project forward over the head must depend much upon its height or distance above the head. The light should reach the head at about an angle of 45°, so that a canopy a yard and a half above the head should project about a yard and a half over it. There need not be a screen or wall on both sides necessarily; but if you have a wall on one side you will find a screen of three or four feet wide, and about as many feet from the sitter on the other side will help you to get softness, and prevent too much light falling quite on the side of the face. To prevent diffused light entering your lens, attach to it a large conical hood of cardboard blackened inside, and projecting about a foot, in size and shape something similar to a sugar loaf, but expanding a little more.

A MAN FROM THE COUNTRY.—The stain on the background of your negative appears to have arisen from an accumulation of the silver solution having drained to that spot, and become precipitated there by the developer. Try placing a strip of blotting paper along the bottom of the plate, which will absorb any surplus drawings. We have met with the tendency as you describe in a new bath, and there is something not explained in the circumstance that it should occur especially in a new bath; but we think you will find the remedy efficient. The general chemical quality of your negatives appears pretty good. Report on your glass in our next.

J. JONES.—We do not necessarily indorse or approve all the formulæ we publish, and amongst other things we do not recommend or practise ourselves, is the adding of alcohol to the nitrate bath. The ammonia nitrate bath with nitric acid added until it is neutral gives exceedingly good results. Let any turbidity subside, or if necessary, filter the solution.

ALPHA.—We think the lenses of the best English makers are decidedly preferable to the common French articles. The superiority consists in a variety of points, such as better definition throughout, greater rapidity, &c. We cannot, in fairness, recommend any maker by name. See our advertisement columns.

TOMPKINSON.—The *sel d'or* toning bath is a mixture of hyposulphite of soda and gold. Dissolve one grain of chloride of gold in an ounce of water; in another ounce of water dissolve three grains of hyposulphite of soda; now pour the gold solution in the hypo solution, agitating it during the process. Dilute with a couple of ounces of water, and when any turbidity or milkiness has subsided, filter, and it is ready for use. This process is now rarely used, as it has been abandoned for the alkaline gold process, which gives better and safer results.

G. H. M.—Fresh glasses generally need no other cleaning agent but alcohol and tripoli. Glasses that have been used should be cleaned with the same, with the addition of a little nitric acid; a little iodine may also be added with advantage; finishing with alcohol alone. If the plates are well cleaned, and the edges carefully rubbed to remove adhering particles, there is no danger of the bath suffering.

A. TANNER.—About four grains of the iodide of magnesia, and one or one and a half of bromide of magnesia, may be used with advantage in each ounce of collodion. It is desirable to evaporate the nitro-muriatic acid as closely as possible, without inducing decomposition, but it is necessary to be very careful towards the close of the operation, and work with a low temperature, or decomposition may suddenly take place.

J. B.—See article on "Glass Houses," in the present Number. A modification of Mr. Sutton's principle—getting a little more light—will probably suit you better than the design with top light only.

F. TABLE.—A combination of softness and delicacy with brilliancy is necessary to good results. In the earliest set, No. 1 is the most perfect negative, but it is not a good print, being too lightly printed. A little more printing would have given depth and richness to the drapery, and more roundness and modelling to the features. No. 2 is brilliant, but a little hard; a trifle more exposure, and less developing or intensifying, would have improved the picture. No. 3 is better in these respects; but it errs a little on the side of softness; it wants a little force. A medium between No. 2 and No. 3, or a combination of some of the qualities of both would give a fine result. If you examine the face of No. 2, you will find patches of white without any detail or drawing, which should never occur, and no richness or perfection of the drapery will compensate for this.

W. C. MARKET RASEN.—A longer immersion in the toning bath will give you deeper and blacker tones; but the highly albumenized *Rive* paper on which your print is produced is often difficult to get beyond the chestnut tone of your specimen, a tone which, however, many persons prefer. A few lessons from a capable instructor will be valuable; but we do not know anything of the qualifications of the gentleman to whom you refer.

ALEX. ARNHEIM.—Thank you for the samples of paper prepared with gutta-percha, we will take an early opportunity of trying it.

ONE WHO WANTS PRACTICE.—The print received is a specimen of imperfect fixation. The hyposulphite bath is too weak, or old and exhausted, or the prints have stuck together so that the solution did not act properly upon all. In this case the latter is probably the fact, as you state that some of the same batch were so and some perfect. The effect generally is first seen whilst the prints are washing. Prints perfectly washed before toning or after toning are much less liable to this mischance. There are no means of ascertaining when a print is fixed by its appearance. The only certainty can be obtained by taking care to observe all necessary precautions, such as careful washing, using fresh, strong, neutral hypo solution, keeping the prints in motion and free from sticking together, &c.

GEORGE DRAPER.—We did not find any print enclosed in your letter. Possibly a little alcohol will prevent the stains to which you refer; or possibly they may arise from the drainings of the plate; we tell from your description. 2. You may, without impropriety, defer intensifying until the close of the day, as is the custom with many artists. You may either allow the negatives to dry, or keep them in water just as you prefer; with the latter plan there is some chance at times of the film becoming loose.

F. L. S., EDGE HILL.—The chief fault of your pictures is the use of too much front light, giving the faces a uniform and flat effect, you want more distinctly marked light and shadow to give more relief.

A. WOOD.—We are obliged by the examples of the effect of steaming; which seem strikingly to prove its value. We shall look with interest for Mr. Nichol's paper on the subject. We should like to know something of your photolithographic process. We have not yet exposed the piece of excited paper, so that we shall learn something of its keeping powers.

A. BURNS.—The cards received; we will write shortly.

Y. Z.—Your sample of glass is very excellent, and may be used in the dark-room with perfect safety.

Photographs Registered during the Past Week.

MESSRS. W. AND D. DOWNEY, 9, Eldon Square, Newcastle-on-Tyne,
Two Portraits of John Bright, Esq., M.P.
Portrait of George Dawson, Esq.

MR. JOHN STUART, Glasgow,
Two Photographs of Rev. Niel Brodie.

MR. BROTHERS, Manchester,
Portrait of late Rev. W. J. Ffarrington.
Two Portraits of Rev. J. Atkinson Longsight.

MESSRS. C. A. DU VAL AND CO., Manchester,
Photograph of Colonel Grealish,
of Earl of Derby.

MR. THEOPHILUS SMITH, Sheffield,
Two Portraits of John Brown, Esq., Mayor of Sheffield.

MR. E. T. BROOKS, Newbury, Bucks,
Portrait of the Rev. the Warden of All Souls,
of Archdeacon Foulkes,
of Rev. T. T. Carter,
of Rev. T. V. Fosbury.

THE PHOTOGRAPHIC NEWS.



Vol. VII. No. 230. ~~14th~~ 13, 1863.

CONTENTS.

	PAGE
Skies in Photographic Landscapes	121
Critical Notices	122
An Experience with the Old Hypo Bath. By Carl Meinertzh ...	123
On Some New Principles of Direct Photographic Printing on Paper. By M. Poitevin	124
Expedient Method for the Comparison of Photographic Substances. By M. Mc. A. Gaudin.....	125
A Simple Method of Choosing Glass for Operating Rooms.....	126

	PAGE
Theory of Positive Printing. By George Price	126
A Short Lesson in Photography.—No. 9.	128
The International Exhibition.—Report of the Jury.....	129
Correspondence :—Foreign Science, &c.	129
Talk in the Studio	132
To Correspondents.....	132
Photographs Registered during the Week	132

SKIES IN PHOTOGRAPHIC LANDSCAPES.

WHITE skies are no longer the "fashion" in photographic landscapes. A few years ago a photographic exhibition scarcely gave us examples of anything else in the shape of landscapes, but a foreground, surmounted by white paper in place of sky, or "buildings," to use the words of Lady Eastlake, "of rich tone, and elaborate detail, upon a glaring white background, without the slightest form or tint, like a Chinese landscape on a looking-glass." The "light having burnt out all cloud-form in one blaze of light." That which originated in a defect soon became a fashion, and the speckless sky, without the suspicion of a tint, was regarded as the pride of the picture. In the last Photographic Exhibition white skies were the exception; natural clouds, or graduated tints, were everywhere present. It is unnecessary here to dwell upon the immense pictorial value thus conferred upon each subject. A white patch of paper destroyed all brilliancy by killing all the lights in the picture. It destroyed all atmosphere by killing the delicate tints of the distance, and making that which should be afar off—the sky—the most prominent and staring part of the picture. It destroyed all breadth by cutting the picture into two distinct patches of light and dark, without harmony or connection. As a higher appreciation has been growing amongst photographers, a few words on the various modes of producing skies may not be uninteresting.

There are at least half a dozen modes in which skies are produced in photographs. The first and most obvious is that which is least under control, being possible only under certain conditions, namely, the production of clouds at the same time as the foreground, as in instantaneous photography. The second is by contriving during development to bring out the forms of clouds present during exposure, and to avoid over-intensifying them to that condition in which they never print through. The third is by managing to give the sky a minimum exposure while the foreground receives its full time. The fourth is by printing in clouds from a separate negative. The fifth is by painting or otherwise working on the negative. And the last is by exposing the sky to light after the print has left the pressure frame, so as to secure a graduated tint.

On the method of obtaining clouds by rapid or instantaneous exposures, we need not say much here. A cloudy sky surmounting a well illuminated foreground, containing no very dark objects very near to the camera; a highly bromized collodion and iron development, together with skill and judgment in selecting subjects and manipulating, are the chief requisites here.

Management in developing gives, under some circumstances, great power over the sky to the skilful operator. In some large pictures we have recently seen, by Mr. R. Gordon, of the Isle of Wight, of which we shall have more to say shortly, very good natural clouds were secured in negatives requiring eight or ten seconds' exposure. It will be assumed at once that the clouds in such instances had

not been in very rapid motion. This is a circumstance which not unfrequently occurs; but it in general happens, that in developing in the usual manner, the clouds which come out rapidly in development as rapidly disappear in one uniform mass of intensity, being buried by the amount of development necessary to bring out the foreground. To meet this difficulty, Mr. Gordon adopts a very ingenious method. Instead of applying the developer in its ordinary strength, he uses a one-grain solution of iron without any acid whatever. This, in a few seconds, brings out the delicate cloud forms, when there are any present, and to some extent the foreground. When its operation has been carried sufficiently far, the developer, which contains also the free nitrate, is poured off the plate, and a portion of fresh iron solution and acetic acid added to it sufficient to make a developer of the ordinary strength, suitable for the collodion in use. Mr. Gordon generally uses a similar solution to that of Mr. Vernon Heath, namely, 8 grains of iron and 20 minims of acetic acid. This solution is now applied to the plate, confining it chiefly, but not exclusively, to the foreground. The whole of the detail sufficiently out, sufficient intensity is secured by a two-grain solution of pyrogallie acid and a few drops of silver. By this means a negative is obtained, in which the cloud-forms are not buried in one mass of intensity, but print sufficiently to give harmony and atmosphere to the picture. It will be seen that this method is analogous to that used by Mr. Mudd, with dry plates, in which a plain solution of pyrogallie acid is applied until the clouds and general details appear; the ordinary pyrogallie solution, with citric acid and silver being then applied to give intensity to the foreground.

Various contrivances have been tried for protecting the sky whilst the foreground received its proper amount of exposure. Mr. Scott Archer had a plan of tearing a piece of paper to a form corresponding with the horizon line in the view to be depicted, and placing it inside the camera in a groove, so that it cut off the sky during part of the exposure, when it was removed to give the sky a few seconds only. The flap shutter placed before the lens has frequently been used to partially shade the sky; but this is only available when no tree, spire, or other object materially breaks the level of the horizon. Mr. Mann has recently patented a shutter, which it is stated can be made to adapt itself to any line dividing the sky and landscape, however irregular, and thus give absolute control over the respective exposures for each part.

The method of printing-in a sky from a separate negative is pretty well known. Mr. Samuel Fry was, if we remember rightly, one of the first to call attention to the advantages of this method, which he described in our pages some time ago, when its legitimacy was the subject of considerable discussion. It was alleged against this plan, that to secure truth and harmony, the landscape should only be accompanied by the same sky which was over it at the time when the picture was taken. It was argued, on the other

hand, that the portion of the sky seen by the lens was not necessarily that which, by the reflections of clouds, &c., affected the portion of the foreground seen by the lens, and that if care and judgment were used in selecting the sky for each subject, harmony might easily be secured. This plan has been gradually gaining popularity, and is now practised by many of our best photographers, amongst whom we may name Mr. Vernon Heath, Mr. Maxwell Lyte, Mr. Annan, Mr. Archibald Burns, and others. Two or three points demand imperative consideration. The clouds must be lighted in a similar manner to the landscape, and must be of a character to harmonize with it. Nothing would be more incongruous than heavy dark masses of cloud in the sky, when the landscape, perhaps, presents a lake which reflects only bright sunlight. Care must always be taken that the sky be lighter, more atmospheric, and less substantial looking than the foreground. As a general principle, the more light, indefinite, and less pronounced the clouds, the better will be the effect. It is scarcely necessary to say that in using this method immense power is placed in the hands of the artist in balancing his composition, and making a picture out of unpromising materials.

The method of painting on the negative has been often attempted, but rarely with complete success. Indeed it can scarcely be expected that it should be successful in other than the hands of an artist. The Eastern pictures of Mr. Francis Bedford afford the best example of successful treatment of this kind that we have seen, and the effect is marvellously fine. It is a necessary condition in this case that the sky of the negative be not too dense; it must print through, giving an appreciable tint. The clouds may then be carefully painted at the back of the negative; or they may be painted on thin semi-transparent paper like tracing paper, which can then be placed at the back of the negative. The safest plan is that adopted by Mr. Mudd who contents himself with a few delicate stratus-like clouds near the horizon, which are just sufficient to break the blank of white paper, and give some gradation.

The simplest plan of avoiding a mass of white paper for a sky consists in giving graduated tint by exposing the print, after it has left the pressure-frame, to the partial action of light. This, if done with care and taste, preserving light in the horizon and running into a darker tint higher up, avoiding at all times too deep a tint, or one in any degree as heavy as the shadows of foreground objects, is often very successful and satisfactory, and can very rarely be offensive.

We do not here enter into the question of the legitimacy of any of these methods of giving pictorial value to the photographic landscape beyond reiterating a conviction we have often expressed, namely, that in such matters success is the touchstone of legitimacy.

Critical Notices.

INSTANTANEOUS AND OTHER STEREOGRAPHS.

By G. W. WILSON, Aberdeen.

WE have recently received a further series of Mr. Wilson's exquisite instantaneous and other stereographs, amongst which we find some of the most perfect photographs we have seen. The instantaneous pictures are wonderfully fine and full of life and motion: three of the Thames at Greenwich—"Waiting for the Boat," "Arrival of the Boat," and "Departure of the Boat"—are excellent examples. The crowded pier; the transparent water; the forests of masts which form the distance in which looms heavily, with tier upon tier of decks, the noble hospital ship; the fine clouds all combine to make most picturesque views. "The Thames at Woolwich" (No. 418) is another exquisite slide, low in tone, but wonderfully delicate, detailed, and soft, and a most admirable example of composition. The "Victory Flag Ship, at Portsmouth," is another fine slide, as brilliant as the other is soft.

There are many more of the instantaneous pictures of marine subjects which are very fine; but the slides in this series which please us most are the views of Highland scenery, which far exceed any views of the same or similar subjects we have seen. Here is a series of Loch Katrine, which is inexpressibly beautiful, so perfectly chosen as regards point of view, so brilliant and delicate, so full of gradation, from the tender greys of the distance to the forcible and bold relief of the foreground and the transparent depths of the water. No. 10 B, "Loch Katrine and Ben Venue," is an admirable example of this series, as is also "Ellen's Isle" (No. 36), the sparkling little lights of which more resemble the work of the engraver than the lens. "Loch-na-gar, Balmoral," is another noble slide of the same series.

A series of interiors and exteriors of English cathedrals includes some exceedingly fine pictures, amongst which we like those of Durham best. A view of the cathedral from the river Wear (No. 380), is exceedingly beautiful. The interior of the "Galilee, or Lady Chapel," in Durham Cathedral, is very fine, and renders very perfectly the fine examples of Norman arches. No. 407, the "Lady Chapel" interior, in Winchester Cathedral, is an exceedingly fine study of lighting and perfect chiaroscuro. Amongst some other very fine interiors, perfect in lighting and manipulation, it is to be regretted that there is not an entire absence of curved, or converging, perpendiculars. With this exception, in a few instances, the whole of the pictures before are perfect examples of art-photography, forming not only some of the most pleasing slides ever issued to the public, but containing most valuable studies for young photographers to adopt as standards of excellence to which they should try to attain.

INSTANTANEOUS VIEWS OF LONDON. &c.

By VALENTINE BLANCHARD. London: C. E. Elliott, Aldermanbury Postern.

WE have here a further series of Mr. Blanchard's instantaneous views of London streets, and marine and river scenery, of which we have repeatedly had occasion to speak in very high terms. The slides before us include some of the most interesting, and, at the same time, most difficult street scenes in the metropolis, the difficulties here being increased by including vehicles, on a large scale, in the immediate foreground. We have not space for a detailed notice of each slide deserving notice; but we may mention as amongst the street scenes, which please us best, "Regent Circus, Piccadilly" (No. 204), which is a very charming soft picture, with natural clouds, falling exactly in the right position for balancing the composition; "London Bridge," from Southwark (No. 220), is also a fine slide. The marine and river scenes are our favourites, and these include many charmingly artistic bits. Here is "The Thames at Richmond" (No. 228), somewhat low in tone, but a most charming little picture, with a fine sky; it includes the bridge, boats, &c. No. 235, a "Study at Tilbury," of an old paddle steamer laid high and dry upon the strand, is also very fine. No. 240, "Gravesend from Tilbury," is another very artistic view. We might easily go on selecting choice specimens, but we must forbear, simply heartily commending the series to the attention of lovers of artistic photography.

RAMBLES ABOUT CHESHIRE. Photographed for the stereoscope, by J. H. UNDERWOOD.

THIS is a continuation of a series we have before had pleasure in noticing and commending. It includes some very pleasant bits of rural scenery, very perfectly photographed: great brilliancy, combined with detail and softness characterise all the pictures.

VIEWS IN NORTH WALES. Photographed by JACKSON Brothers, Junbo and Oldham.

NEARLY a couple of years ago we reviewed a series of photo-

graphs, chiefly consisting of rural studies and landscapes with figures, by Messrs. Jackson Brothers, which struck us at the time as unusually picturesque and artistic. We have here a series of views in North Wales, which, whilst different in character, consisting of natural scenery rather than artistic studies, are selected and executed with equal artistic feeling, with one slight drawback, however, namely, that in some instances we have white skies. In all other respects this is one of the best series of photographs of Welsh scenery we have met with.

TRAITE GENERAL DE PHOTOGRAPHIE, Comprenant tous les Procédes connus jusqu'à ce jour. Par D. V. MONCKHOVEN, Quaterième Edition, Paris: Victor Masson et Fils.

The fourth edition of Dr. Van Monckhoven's *Traité Général* has been entirely re-written, and is, perhaps, the most complete work on photography in existence, treating most fully alike of the theory, practice, and scientific applications of photography, and being illustrated with upwards of two hundred and fifty engravings. We heartily commend it as a work which should be in the library of every photographer who reads the French language. Dr. Monckhoven is not only a careful and conscientious compiler, but himself a man of high scientific attainments, and a high authority in the chemistry of photography.

REPertoire ENCYCLOPEDIQUE DE PHOTOGRAPHIE. Par H. de la BLANCHERE. Tome I. et II. Paris: 39 Boulevard de Capucines.

This is another very comprehensive French work of reference on the art of photography, and professes to comprise, in alphabetical order, all which has been published in France and other countries since the discovery of Daguerre and Niepce on the art of printing by means of light, and of chemistry, physics, and art, so far as they relate thereto. The alphabetical treatment of all matters photographic is completed in two closely-printed 8vo. volumes; but to keep pace with the progress of the art, the work is continued in monthly parts, which recommence the alphabet, and proceed to include the progress of the art to the latest possible period. The work displays great research and care, and is invaluable as a work of reference on the history, theory, practice, and applications of the art.

TRAITE DE L'IMPRESSON PHOTOGRAPHIQUE SAN SELS D'ARGENT. Par ALPHONSE POITEVIN, avec une Introduction par M. Ernest Lacan. Paris: Lieber

A most interesting history of the origin and progress of the various methods of obtaining photographic impressions without the salts of silver, whether by carbon, photolithography, or photographic engraving. To all photographers interested in this branch of the art, so important in an economic point of view, this brochure will be most welcome, both as recording the history and describing the methods of operation. The value of the work is most materially enhanced by illustrations, produced by the various processes described, including a carbon print, containing very perfect half-tone. The book is manifestly the work of one with whom the art, to the progress of which he has contributed so much, has been a most all-absorbing passion. We notice in some cases, that he has fallen into some inexactitude in dates, but there is a manifest desire to perform the work in careful and conscientious spirit, and we commend it very heartily for its practical value.

AN EXPERIENCE WITH THE OLD HYPO BATH.

BY CARL MEINERTH.

[WE have received from Mr. Carl Meinertth of Portsmouth, New Hampshire, U.S., a series of prints, in illustration of an article in the *American Journal*, to which he calls our

attention, and which we here subjoin. The prints include some exceedingly fine specimens of photography, and are very perfect in tone. The colours vary from a deep rich warm neutral tint to a deep black, and, notwithstanding their long immersion in the old hypo bath described, they have not the faintest indication of the yellow tint we generally find accompanying the blacks so produced, and which so oft-n indicates incipient decay. The prints are card vignettes, presenting therefore, a large surface of white, which is exquisitely fine. So far as there is present indication, the tones are good, and with every promise of permanency. How far that promise will be fulfilled, time alone can decide. In the mean time, we are bound to add that the alkaline gold process is, we think, the most trustworthy method we at present possess.—Ed. P.N.]

When a vicious boy changes his mind, repents his sins, and by degrees in his later days becomes a good man of estimable character and qualities, we ought not surely to condemn him for ever for his juvenile sin. Would that we could say so with some hope of the old boy, Hypo, whose pranks made him so odious with us, that he was despised and turned out years ago, with disgrace, so much so that we now feel almost ashamed even in mentioning his name; and one must fear to be considered a candidate for some certain asylum, if he dares undertaking to restore him to society. Yet who of us would not be willing to welcome him back to homo and hearth if he could and would give up his rank habits and unstable qualities, for the slow but lasting virtues of his younger golden brother, Alkaline?—the "gold-solin'chen," as the Germaus would call him.

But let me report an accidental case of experience with the boy, which induced me to extemporise in these charitable mediations in his behalf:—

In May, or June of last year, I prepared a "rich toning and fixing bath," for experiment, and for quick work (as for any other I have used none but the alkaline), which as usual produced very fine tones, but the whites turned yellow after a few days, and even as soon as the prints were dry; now, these yellows even in pictures of no intended value or durability, can, to use a vulgar phrase, make any one mad! Well; so after they appeared, young master Hypo, after this first exploit of yellowizing that batch of prints, was corked up, and put into the dark closet, until I could treat him to a dose of ferri sulphas, to disgorge the gold from his pockets, in order to prevent further mischief by temptation. But this was never executed, and he was left in statu quo until about two weeks ago—thus eight months.

Gathering up, as I said, about two weeks ago, old bottles and solutions, I came across the old offender, and as it were, wishing to give him the last chance for repentance, poured him out into a dish and threw a handful of over-printed, unwashed albumen prints into it. This was in the afternoon; other business made me neglect these prints entirely, until the next morning, when to my surprise I found them beautifully white or black, and the solution perfectly clear. I soaked the prints for only about an hour in one water, still suspiciously expecting that they would turn yellow after drying; but they did not, and have so far not shown any symptoms of the yellow fever, and also look not likely as if they would [I enclose a few of those original prints, and beg for your opinion, Mr. Editor, of their toning quality, and for preserving them, and reporting on their stability at some future day.]

Now to sum up: this bath was eight months old; the prints were left in it eighteen hours, and received only one hour's soaking afterwards.

The tone of them is, in my humble opinion, —; (but let the Editor speak), and the white of the vignette is as pure as the edge of the surrounding card.

When this same bath is freshly prepared, prints toned in it in thirty minutes and washed very carefully in warm, and then in running water for four hours, go to "lemons" very soon, if not already while drying. But I must mention the composition of the bath:—

Water	16 ozs.
Hypo	8 ozs.
Sal ammoniac	2 ozs.
Nitrate of silver	40 grs.
Gold...	15 grs.

The result of the present experiment seems to indicate that

age is the agent which produces in the hyposulphite bath, as in LeGray's, and in fact in a great many chemical combinations or mixtures, an important and most favourable change. It seems to lose its rank "yellowizing" quality, so that even an excessively prolonged time of toning and fixing will not injure the albumen print, nor the middle-tints of the picture.

As the old rule is, in order to obtain the best possible results, to prepare the bath fresh every time, to tone and fix as quickly as possible, and to wash as much as possible; yet the experiment above was made under exactly the reversed conditions, and has produced a very superior result.

However, at the first glance, we may ridicule the idea, that such a bath which requires half a year waiting, and a whole day toning, should be worthy of any consideration in view of exchange for the trouble of washing, with the alkaline bath, even if the photographs toned therein should really prove equal in keeping with those toned in the latter. Yet an amateur, as well as "operator," will, after a little reflection, agree that such a bath, even if not preferable, is not undesirable; and consequently a step towards its perfection not so much out of the way. We must perceive, of course, that neither "eight months" nor "eighteen hours" are requisite for obtaining good results, as that amount of time was merely accidental. I have since got very fine tones in half an hour's toning in the same bath, whereof I also enclose a specimen. As to the *age* of the bath, it is probable that it may work as well after four weeks as after as many months: which fact further practical experiments alone can prove.

ON SOME NEW PRINCIPLES OF DIRECT PHOTOGRAPHIC PRINTING ON PAPER.

BY M. POITEVIN.

In the new principles of permanent printing in carbon or other inert pigment, which I submit to the Photographie Society, the pigment remains, as I proposed in 1855, imprisoned in an organic material, originally insoluble, and remaining so in those portions not acted upon by light, or coagulated in certain parts only of the impressed surface. I append some proofs to my description, for which I crave much indulgence: accustomed as we now are to see only perfect photographs obtained by processes arrived at the highest degree of perfection, it is an act of temerity to exhibit imperfect specimens obtained from immature processes. In these experiments I have had everything to do under the worst possible conditions; first, from bad weather, for these new experiments only date from November last; then the study of the materials and their proportions, the particular quality of the paper, as well as of the negatives inappropriate to this kind of printing. However, if these first proofs do not militate in favour of the process, we may judge by the description of the principles, what we may be able to obtain hereafter with great facility and at little expense, as we operate directly upon the paper, the use of collodion for transfers, indispensable in my former processes, being now surpassed.

The first principle, that which I have most followed up to the present time, rests upon a well known reaction—the insolubility communicated to organic matters, such as gum, albumen, gelatine, &c., by *maximum* and analogous salts of iron, the perchloride, for example, and upon a new fact which I have observed, which is, that this matter coagulated and rendered insoluble in cold or warm water, becomes soluble under the influence of light, in presence of tartaric acid, which reducing the ferric compound, restores the organic matter to its natural state. Gelatine is the substance with which I have succeeded best. The following is my mode of operating.

I dissolve 5 to 6 grammes of gelatine in 100 grammes of water, and add sufficient quantity of carbon or other inert pigment to obtain the intensity of tone I desire to produce. I pour this solution into a flat dish, and keep it warm so as to prevent the gelatine solidifying. Each sheet of paper is floated on one side only on this solution, and a uniform coat of coloured gelatine adheres to it; I then place the sheet of paper on a flat surface and leave it to dry spontaneously.

To sensitize these sheets, I impregnate them on both sides with a solution of perchloride of iron and tartaric acid in the proportion of 3 to 1. The quantities which have appeared to me most suitable being 10 grammes of perchloride to 100 cubic centimetres of water, and 3 grammes of tartaric acid. I leave the sheets thus prepared to dry in the dark; then the coating of gelatine has become completely insoluble, even in boiling water. I print these surfaces from positives on glass or on paper, and in all those portions upon which the light acts, the coating becomes soluble in warm water; this solubility, be it understood, commencing from the surface. After a few minutes' exposure to the sun, if the positive *cliché* be not very dense, which is preferable for this kind of printing, I remove the paper from the printing frame, and immerse it in warm water; thereupon all the parts which have been modified by light dissolve in proportion to the quantity of light which may have passed through the various portions of the positive *cliché*. In the parts corresponding to the lights of the *cliché*, the black or colored coating will be dissolved down to the surface of the paper, leaving perfect whites, while in the half-tones a part only of the coating will dissolve, commencing with the surface, and these half-tones will be rendered upon the greater or lesser thickness of the coating of gelatine remaining insoluble; and as this part is in immediate contact with the paper, it cannot be removed by washing: as to the portions of the negative which are entirely black, they will be rendered by the entire thickness of the primitive coating.

To complete the proof, it is only necessary to dry it in the air, or treat it with water acidulated with hydrochloric acid, which removes the stain of salt of iron, then to wash it freely in water, and dry it again spontaneously. It is now unchangeable, but a tanning of the gelatine, accomplished by known methods, with alum. bichloride of mercury, &c., will give it greater solidity. Before this fixing we can make whites wherever they may be required, by means of a pencil dipped in warm water.

We do not encounter such dangers in this method as presented themselves in that I proposed in 1855, in which I employed a coating of gelatine mixed with an alkaline bichromate and carbon, and which I printed by means of negatives: for in that method the gelatine was rendered insoluble by light, commencing at the surface, and the half-tones were removed in the washing, undermined from beneath by a portion of the coating remaining soluble. The method I now propose does not possess this inconvenience, and to obtain perfect proofs by it requires only suitable paper with a glazed surface, uniformly coated with a film of the coloured preparation, which will be found easy to realize in practice. The proofs I now present have not been obtained under these favourable conditions, and must therefore be considered only as the products of a new reaction, and the *débuts* of a process.

As to the second principle, it is only a new application of a known reaction, the coagulation of an organic substance in solution by a salt of iron or by a vegetable acid. It consists as follows:—The paper, impregnated with perchloride of iron and tartaric acid dissolved in the proportions indicated in my mode of printing on glass, having been exposed to the light through a positive *cliché*, obtains the property in all the parts which have not been acted upon by light, of precipitating caseine (e. g., of milk) in solution on its surface. I therefore mix the pigment in powder with a solution of caseine, alumina, &c., and I immerse the impressed paper in it, and a layer more or less thick is formed upon the portions not solarized proportionably to the half and whole tones of the *cliché*; if we replace the caseine by gelatine, the latter goes to the solarized portions. In either case the organic matter carries with it a certain quantity of colouring material, holds it imprisoned, and forms the picture. I shall again recur to this reaction, so easy to practice, and exhibit proofs so obtained.—*Bulletin de la Société Française de la Photographie.*

EXPEDITIOUS METHOD FOR THE COMPARISON OF PHOTOGRAPHIC SUBSTANCES.

BY M. MC. A. GAUDIN.

In order to be able to make the numerous trials I have undertaken in that branch of photography which relates to the employment of collodion for the formation of images in the camera-obscura, I contrived a process at the same time comparative and expeditious, of which I have spoken before, and now proceed to describe in full, being persuaded that it will be found useful to photographers on many occasions.

At the present day the main thing is sensitiveness, and that has been the steady aim of all my efforts for more than twenty years. Notwithstanding the multiplicity of my attempts, of which no one can form any idea, I have discovered very little; but this has not discouraged me, and in any case this process will be very useful in practice, if it does not become fruitful in inventions in the hands of every body.

Success in photography depends particularly upon the mutual accord existing between the collodion, the silver bath, and the developing agent, which is fully realized only in taking proofs; but to appreciate the sensitiveness the question becomes complicated with that of the intensity of the light, and the focal distance of the objective and its diaphragm, the time of exposure, the nature of the object, and the intensity of the image obtained: so that, the operation concluded, we find ourselves greatly embarrassed to decide the principal question started, namely, the sensibility. While, with the process I now proceed to describe, we can, at all times, by night as well as by day, prove the effective sensitiveness of its products on the relative sensitiveness of two collodions, with great promptitude, and without any apparatus.

We employ plates of glass eight inches long and two inches wide, which, by their elongated form, permit of our operating upon a small scale without the contact of the fingers or frames, which is often the cause of the proofs becoming fogged. After pouring the collodion upon the extremity of the plate, so as to cover a space of two inches square, we immerse this extremity, collodion downwards, into the dish containing the silver solution, the other extremity resting upon the edge of the dish, which must be covered with a piece of card-board. After sensitizing, we place upon the back of the plate a piece of moistened yellow paper, cut square or triangular, which adheres, and we then present this paper to the flame of a candle, at the distance of four inches, counting seconds from 0, 1, 2, 3 to 9, removing the paper between 9 and 10. By this means we have, side by side, two exposures; the one of ten seconds, the other of one only, which, after the application of the reducing agent, will mark, if the sensitiveness is at the maximum, the one, an intense black, the other, sensibly of a half tint; but if the sensitiveness is weak, the exposure of ten seconds only will be marked.

We at once understand that this manner of operating gives results always comparable at any season, and at any hour of the day and night. If the developer is susceptible of fogging, it will show itself after the washing with hyposulphite of soda, the space left masked in the last place by the screen of yellow paper will not appear perfectly black upon a black ground, provided, however, that it be held three feet from the candle during development.

To compare the sensitiveness of two collodions is also very easy: we pour on the extremity of the glass plate a film of each collodion, thus forming two contiguous squares, which are sensitized together; and after placing at the back a slip of yellow paper across the line of separation of the two collodions, and impressing these collodions by the light of a candle as before described, upon the application of the developing agent, we may clearly ascertain which is the most sensitive of the two collodions.

With 150 grains of collodion we can make twenty trials in an hour. It is by following this method that I have

recently made numerous experiments upon the introduction of iodide of silver, protochloride of tin, and the iodides of iron, tin, and antimony into the collodion.

Iodide of Silver in Collodion.—The introduction of iodide of silver into collodion appears to me a good way of increasing the porosity of collodion and augmenting its sensitiveness. This idea is not a new one, as the first collodions prepared contained iodide of silver, but theoretic notions have caused this accessory to fall into disuse. Still, it is quite certain, that when iodide of silver exists in collodion at the same time with iodide of potassium, we need not fear that the iodide of silver will be impressed by light, since, on the contrary, if it were impressed in advance, in the highest degree, the contact with iodide of potassium would restore it to its original state. During my long researches upon the *photogène* for collodion, I have been led to believe that most of the iodides act upon iodide of silver, like the iodide of potassium, but in a much less degree. This is why I have introduced some iodide of silver into a collodion iodized with iodide of cadmium, working well, and I have left the bottle exposed to sunshine for half an hour. When I afterwards coated my slip of glass impressed by the flame of a candle, I obtained as pure an image as ordinary. I have, therefore, concluded that iodide of silver, with excess of iodide of cadmium, is *insensible* to light, and that we may carry the addition of iodide of silver to collodion very far. Only the great difficulty is in obtaining it in the collodion in the nascent state, and not in the state of suspension: in the nascent state, the collodion is opaline, just like a sensitized film, and the iodide is never precipitated, while, if in a state of suspension, it very quickly subsides to the bottom of the bottle if left to repose. This difference in the behaviour of iodide of silver declares itself at once under very different circumstances: for example,—to prepare collodion with opaline iodide of silver, it is better first to introduce into simple collodion a drop or two of a concentrated solution of nitrate of silver, then to add the alkaline, or metallic iodide, in the usual proportion, and shake the bottle until the whole is dissolved. By adding nitrate of silver to collodion already iodized, the collodion almost always *turns*, and the iodide very quickly separates upon standing, with the exception of a very minimum portion, which is incapable of producing the least useful effect.

Protochloride of Tin in Collodion.—The protochloride of tin, introduced in a *very minute* quantity into collodion, iodized or not, produces an extraordinary effect—fully comparable to that of gallic acid: after sensitizing, the film has assumed a light-brown hue, which is not modified by the action of light; so that a plate thus prepared and exposed yields no image, but under the action of the reducing agents its whole surface assumes a uniform red hue of extraordinary intensity. The addition of free iodine to this collodion ultimately gives sensitive plates, so that protochloride of tin produces the opposite effect to free iodine; and in the present case it may serve for this latter. A collodion become very red by old age will almost immediately recover its sensitiveness by the addition of a few drops of a collodion prepared in the ordinary proportions with protochloride of tin. The reason of this phenomenon is very simple: the protochloride of tin, in presence of nitrate of silver, forms chloride of silver and nitrate of per-oxide of tin, which immediately gives rise to the formation of deutoxide of tin, which causes the reduction of the silver. Protochloride of tin is already known for reducing the salts of gold, and its reaction is still more marked with nitrate of silver: it takes place instantly, which prevents its employment for developing photographic images.

Preservation of the Ferroso-Acetate.—The preservation of the ferroso-acetate being a condition of primary importance, for its employment as a developer in photography, I have tested it under this relation. I left a pint of a weak solution of it in a wide-necked bottle, uncorked, exposed to the atmosphere for three weeks, using a portion every day, without observing any diminution in its power of reduction,

which proves to me, that, preserved in a concentrated state in a corked bottle, it will keep for an indefinite period of time. It is a bright red liquid, but the iron is not in the state of peroxyde, for ammonia precipitates it green, like all the developers with an iron base, employed to develop negatives. —*La Lumière.*

A SIMPLE METHOD OF CHOOSING GLASS SUITED FOR THE OPERATING ROOM.

The following letter from Mr. England was read at a recent meeting of the Photographic Society:—

DEAR SIR,—Having seen several inquiries lately respecting the coloured glass best adapted for the operating chamber, I am induced to offer a few suggestions, which, in practice, will be found to save much trouble and many failures.

On my visit to several photographic studios, it has surprised me the small amount of light, or rather the large amount of darkness, in which the plates are prepared, developed, &c. Now, by a little care in the choice of proper glass, we may have a window containing as many superficial feet as at present inches, thereby working with much greater freedom, comfort, and certainty, instead of fumbling about in the dark, upsetting solutions, breaking bottles, and losing your—no! I ask pardon, a photographer never loses his temper; a more patient race of mortals has not existed since the days of Job; and should some future Foley or Bailey choose as a subject for sculpture that worthy patriarch, he will, without doubt, wend his way to the nearest "Temple of the Sun" for his model.

But to proceed. Procure from a glass-cutter several pieces of coloured glass, say two inches square; number these, and place them in a pressure-frame, cover with a piece of sensitive paper, and expose to strong light till printed. The results will show at a glance the tint best adapted to stay the passage of the actinic rays. It will then be as well to try the same experiment with a collodion plate, to ensure perfect results.

One of the prints sent has had an exposure of four hours in strong sunshine, and still No. 1 square has received but very slight change. The second print has been exposed a shorter time, and exhibits in a perfect manner the various tints.

The accompanying prints and glass will fully explain themselves.

To the grandmothers of photography, of course, this is but pap; but to amateur infants, perhaps, a little of that article may be acceptable, and which must be my apology for troubling you.

W. ENGLAND.

7, St. James's Square, 3rd Feb., 1863.*

THEORY OF POSITIVE PRINTING.—ALBUMENISED PAPER AND THE ACTION OF THE SENSITIZING BATH.*

BY GEORGE PRICE.

THAT I may not be considered presumptuous, or actuated by motives of vanity, in addressing those who are much more practically conversant with every branch of photography than I am myself, allow me to assure you that I should not have come thus prominently forward had I not been solicited to write a paper for one of our meetings. I have complied with that request, because I consider that every one who becomes a member of our society virtually binds himself to do all in his power to aid the others in their endeavour to acquire knowledge, however humble may be his own abilities; for, though by reading a paper he may not himself be able to impart any information, or even to place his subject in a new point of view, he may, perchance, give rise to a discussion in which many important facts may be elicited.

The subject which was proposed to me was PRINTING; and it is, without doubt, the most important branch of the art, inasmuch as, without it, the others would be comparatively useless, for we should be unable to disseminate throughout the world the beautiful results which photography is capable of producing.

Although we are able to produce splendid prints by very different formulæ, still, it is an undeniable fact, that we absolutely know nothing whatever respecting the theory of positive printing upon albumenized paper; even the philosophy of the action of the preliminary sensitizing bath is but little understood; and

thus many erroneous notions are prevalent respecting it. Notwithstanding I am not conceited enough to imagine that I know any more of the subject than yourselves, it is nevertheless the one to which I invite your attention in order to raise a discussion upon a few points that require elucidation, believing that the illumination of even a farthing insight is preferable to total darkness.

Unfortunately for the progress of science, the majority of mankind have no individual opinions of their own, but accept those of others, without caring to take the trouble of ascertaining whether the opinions they adopt are facts or fallacies. It is, I believe, this universal acceptance of several fallacies as facts, that has so much retarded the advancement of our knowledge respecting the philosophy of positive printing upon albumenized paper. A fallacy is like the fabled *hydra*; if you cut off one head, another springs up to supply its place; and like *slender*, it lives long and travels far and wide. Should we flatter ourselves that we have killed it in England, lo! it makes its appearance in France; when we imagine we have destroyed it in France, we find it resuscitated in America; and when we hug ourselves with the idea that it is deprived of life in America, we are startled by its appearing again in England, enlivened with new life and vigour.

On a sheet of paper, which has been albumenized for photographic purposes, we have a superficial layer of dried albumen in conjunction with a salting chloride, this dried chlorided albumen being soluble in water. Notwithstanding I have written so much in the NEWS, endeavouring to expose the fallacy of the belief that dried albumen can be coagulated, it is necessary to say something about it here, not only in order to have a comprehensive view of our subject, but also in order to clear away much error which exists amongst photographers and scientific men respecting it. Any one who is conversant with the various branches of science must be aware that there is much looseness of expression in giving a name to various phenomena.

It is from this looseness of expression that so much error has arisen from using the word "coagulation." In making use of this term, we should bear in mind that it was originally given as a name for the phenomenon which takes place upon the application of heat to albumen in its normal state; and was intended to signify the production of a *semi-solid opaline mass*. As other agents were afterwards found to produce the same apparent effect, and insolubility was an invariable accompaniment, the expressions "insoluble albumen" and "coagulated albumen," came to be considered as synonymous when applied to the effect produced by these various agents upon normal albumen. Upon the erroneous supposition that what would render albumen insoluble when applied to it in its normal state, would also do so in its dried state—the term "coagulation" came to be mis-applied to dried albumen; losing sight of the important fact that fluidity of the substance to be coagulated is an absolute necessity. It happens, however, that several agents which will render albumen insoluble when applied to it in its normal state, will not do so when applied to it in its dried state; heat and alcohol are the only two of them which it is necessary to mention here.

Notwithstanding the assertions and opinions of many photographers and scientific men to the contrary, I unhesitatingly affirm that these agents (heat and alcohol) cannot render dried albumen insoluble; and, moreover, we have no means whatever of rendering it so; we may form an insoluble compound by chemical combination in various ways, but it is then no longer albumen; and whatever means we employ to do so before sensitizing, will, I believe, render it unfit for photographic printing. I think there can be very little doubt that the term coagulation, as synonymous with insolubility, was applied to dried albumen by photographers before it was recognised that it entered into chemical combination with nitrate of silver; but now, that such is known to be a fact, to say that nitrate of silver coagulates the dried albumen is erroneous in every way. In the first place, as there is no fluidity, there can be no coagulation (according to the original meaning of the term); in the second place, the expression cannot with any correctness imply that the dried albumen has been rendered insoluble, for it is the new chemical compound which has been formed that is insoluble (and to which has been given the name of albuminate of silver) and not the dried albumen *per se*.

The coagulation of albumen by heat, and its (so called) coagulation by chemical agents, are two separate and distinct phenomena; but photographers un-scientifically apply to them the

* Read at a meeting of the South London Photographic Society, March, 12th, 1863.

same term. In *what* way heat coagulates albumen chemists have not yet determined; but no *additional* substance enters into combination with it; it is simply the same albumen in another state; it is not so, however, when chemical agents are employed to produce insolubility; the *generality* of them enter into combination with it, and an insoluble *precipitate* is formed, which is not albumen alone, but a *compound substance*, and no one has any right to *mis-call* it *coagulated albumen*. I have said the *generality* of these chemical agents enter into combination with albumen, because I believe that alcohol simply unites with the water of the albumen, and causes an insoluble precipitate to be formed, with which it does not enter into combination; this may, perhaps, be the case with the coagulating *acids*, as it is not yet satisfactorily determined whether they form any definite compound with albumen; it is, however, otherwise with such metallic salts as nitrate of silver—here a direct chemical combination takes place. I have also said, *we have no means whatever of rendering dried albumen insoluble*; for I maintain that when normal albumen is coagulated by any agents, without their entering into chemical combination with it, those same agents, as they cannot *coagulate* dried albumen, *do not render it insoluble*, the insolubility of the normal albumen being due to its coagulation.

From what I have now stated I leave you to judge whether it be not want of knowledge which can alone induce any one to use the term *coagulation* in any way whatever when applied to dried albumen.

I need, perhaps, scarcely say to those who have paid any attention to the subject, that this fallacious notion of dried albumen being capable of coagulation, *even by heat*, is very prevalent, notwithstanding it is at variance with the dictates of common sense. In a pretty extensive and varied course of reading, I have never yet met with any author, be he photographer or chemist, who has ever stated the *impossibility* of so coagulating it; the most that any of them has advanced is, that it is not coagulated up to a certain temperature.

Mr. Hardwich, in the last edition of his *Manual of Photographic Chemistry*, leads his readers to suppose it to be a *possibility*. At page 470 he says:—"A layer of dried albumen cannot easily be coagulated by the mere application of heat." Now, we all know that when a person says a certain thing cannot *easily* be done, the inference to be drawn from his statement is, that it *can be done* with difficulty. Again, in speaking of albumenized paper, at page 371, he says:—"Some have recommended to press it with a heated iron, in order to coagulate the layer of albumen upon the surface; but this precaution is unnecessary, since the coagulation is perfectly effected by the nitrate of silver used in sensitizing; and it is doubtful whether a layer of *dry* albumen admits of coagulation by the simple application of a heated iron." You will, no doubt, have noticed that he does not say the application of the hot iron is *useless* for coagulation; but, merely, that it is *unnecessary*, because it will be effected by other means, thus ignoring the beneficial effect produced by its desiccating the paper; and you must be well aware that the statement, "*it is doubtful*" whether a thing can be done, is, in fact, an avowed acknowledgement that *it is not certain it cannot be done*.

M. Gaudin, in an article lately published,* alluding to albumenized paper, says that it will be sufficient to hang it in a cellar, or other damp locality, to coagulate the albumen by the passage of a hot iron across its surface; and also that at the time of albumenizing if the hot iron be passed over it before it is dry enough to cease sticking to the fingers, the same effect will be produced. Now, this statement is a *very great fallacy*, for the following reason:—Whatever moisture is imbibed will be evaporated by the application of the hot iron *before* it can arrive at sufficient temperature to coagulate the albumen. The same will also be the case with the albumen in its sticky state. Moreover, as I stated nearly two years ago, *no amount of dry heat* will coagulate or render insoluble a mere film of albumen, *even in its normal state*—it simply dries the albumen; therefore, the albumenized surface of a sheet of paper, whether it be rendered damp after being dried, or be taken before the albumen has ceased to be sticky, *cannot be rendered insoluble by the application of a hot iron*. By the aid of steam and boiling water, the albumenized surface of the paper may perhaps be made to imbibe sufficient moisture for coagulation to take place, but it becomes a question whether this coagulated moist albumen would return to a sufficiently dried state to be fit for photographic printing; but, even if it did so, I believe that this very insolubility would

render it almost—if not wholly—*incapable of being sensitized* by the nitrate of silver bath.

The belief in the fallacy that dried albumen could be coagulated, or even rendered insoluble, naturally induced means to be sought for to accomplish it; but, its being an impossibility, the beneficial effects produced by them were attributed to a cause which had no existence; and thus attention was diverted from the *real philosophy* of their action. "The rapidity with which a substance, soluble in water, is dissolved in it, is dependent upon its more or less hydrated state at the time it is submitted to the action of the solvent; thus, the passing a hot iron over the surface of albumenized paper, by desiccating it, renders it more difficult of solution; and, therefore, the nitrate of silver is enabled to be forming an insoluble compound before the solvent power of the water can come much into play.

Unfortunately, in making the sensitizing bath as we do at present, we use a solvent for the nitrate of silver, which is also a solvent of dried albumen; and thus, with respect to the albumenized surface of our paper, we have two antagonistic forces in operation at the same time—one having power to dissolve, and the other to form an insoluble compound. This being the case, we can diminish the power of either of them by increasing that of the other; and therefore it is perfectly possible, by sufficiently increasing the quantity of nitrate of silver, to almost (if not entirely) neutralize the solvent power of the water. The stronger the sensitizing bath the quicker will be its action, and the more will the albumenized surface of the paper be able to maintain its brilliancy; and I believe it to be possible to make the nitrate bath strong enough to render a mere drawing of the paper across its surface quite sufficient to form the albuminate and chloride of silver with the requisite quantity of free nitrate; and, from the solution not having time to penetrate the substance of the paper, that the prints will have *all* the brilliancy which albumen is capable of affording; and, moreover, that less silver will be wasted than at present, and less washing required; we should also, I believe, then receive the full benefit of colouration which the nitrates of the bases of the salting chlorides would give us. As alcohol is not a solvent of dried albumen its addition to the nitrate bath, by mixing with the water it contains, mitigates its solvent power in proportion to the strength and quantity added; hence the addition of alcohol to the sensitizing bath, and the desiccation of the paper by a hot iron, are *beneficial* because the solvent action of the water has been decreased by their means, and the albumenized surface is enabled to retain more of its brilliancy than it can do without their employment. It is scarcely necessary, perhaps, to say that alcohol must not be added in sufficient quantity to cause precipitation of the nitrate of silver.

In printing upon albumenized paper, it is usually considered that we have present *three* compounds of silver; the albuminate, chloride, and nitrate; and that the *chloride* is the most important of them. I do not hold this opinion myself, but believe that if the chloride be not deserving of being degraded to the *lowest* rank, it only holds a *secondary* one. That the chloride is not of that paramount importance usually attributed to it, is fully evidenced by the beautiful effects produced by the use of low salting formulae. The almost universally accepted theory respecting the production of the image, is, that the action of the light decomposes the chloride of silver, liberating the chlorine; and silver having a greater affinity for chlorine than it has for nitric acid, the silver of the free nitrate combines with this liberated chlorine, setting free in its turn the nitric acid and oxygen with which it had previously been combined; this decomposition and recombination of the chloride of silver going on during the whole time of printing: the vigour and intensity of the print being due to this constant and continued re-composition of the chloride of silver. According to this theory, the presence of the albuminate of silver is entirely ignored, and the free nitrate—as such—plays no part whatever in the production of the image. Were this the case, we could produce the same result by giving *at once* the same amount of chloride of silver as this additional re-composition has afforded, and dispensing entirely with any free nitrate; but experience tells us that this will *not* produce the same effect. I therefore hold the opinion that the nitrate of silver plays an important part *itself* in the production of the image: for surely it is too much to ask us to believe that the chloride can *only* produce a good effect when the nitrate is present; that is to say, that its continued re-production is necessary. The vigour of the print is not, I think, due to the chloride of silver, but to the albuminate; to which is also due the richness of tone. So little is understood of the

* PHOTOGRAPHIC NEWS, vol. vii. p. 5.

action of a solution of nitrate of silver upon dried albumen, that it has not yet been ascertained whether that which we term albuminate of silver, be a combination of the silver salt and albumen, or, a mixture of two compounds; one consisting of the acid of the salt and albumen, and the other of the base of the salt and albumen. Dr. Löwig says:—"If to a solution of albumen we add a solution of metallic salts, as sulphate of copper, nitrate of silver, bichloride of mercury, &c., precipitates are formed, which consist of albumen-metaloxyd and of the compound of albumen with the acids. The latter can be removed with water, whilst the albumen-metaloxyd remains undissolved."

I have said—"In printing upon albumenized paper it is usually considered that we have present three compounds of silver: the albuminate, chloride, and nitrate;" but I believe this idea rests only on assumption, as it has not been ascertained as a fact, whether sensitizing the dried chlorided albumen really produces two separate and distinct compounds of silver, the albuminate and chloride; or whether a double compound be not formed which, for distinction's sake, I will call a chlor-albuminate. The Abbé Pujos makes what I consider an almost astounding assertion respecting the formation of the image upon sensitized albumenized paper. He says:—"A proof when taken from the printing frame, is formed of three superimposed images—the first formed by the albuminate, the second by the chloride, and the third by the nitrate of silver." Supposing the chlorided albumen to be simply a solution of the chloride in albumen, without any chemical combination, we have still an intimate commixture of the two substances; and surely the new compounds formed by sensitizing will also be intimately blended with each other; but, if they be not so, what proof can be given to warrant the Abbé's assertion, that the albuminate will form the lowest stratum.

(To be continued.)

A SHORT LESSON IN PHOTOGRAPHY.—No. 9.†

As ambrotype resembles a melainotype in every respect; it is a positive picture to be regarded by reflected light, and is laterally inverted. The time required for the solar impression, and the mode of development and of fixation, are precisely similar as in the melainotype; the only difference between the two pictures is, that the ambrotype is prepared on glass, whereas the melainotype, as its name implies, is a picture on an iron plate. Inasmuch as the ambrotype is formed on the collodion film on glass, and that the latter substance is transparent, it becomes necessary to coat the posterior surface with either black varnish, black velvet, black paper, or, in fine, some black material to represent the dark background. It is almost immaterial which substance is used, as long as it is uniform in shade and texture; the proper varnish or cloth can be obtained from any of the regular dealers in photographic wares.

The ambrotype, thus prepared, is mounted with mat and preserver in the same manner as the melainotype, and inserted into its case. When thus mounted it can scarcely be distinguished from the picture on the iron plate. It is a much more tedious operation to prepare an ambrotype than a melainotype; for the glass in the first place has to be cleaned thoroughly, which requires much more time than to dust a new excelsior plate; then the varnishing with black japan, or the covering with black cloth, is an operation not required at all with the iron plate; so that, when both these disadvantages are taken into consideration together with the difference in fragility, lightness, and portability, operators give a decided preference to the melainotype, and have by this means almost pushed the ambrotype out of fashion. We will, therefore, leave it to its fate.

The next picture which claims our attention is the all-pervading card picture. No picture has ever had so wide a sphere of action, has gratified fashion and taste so long, or has been as productive of gain to the photographer, as the card picture. Every family, excepting mine, has its variegated album on the parlour table filled with family

likenesses from the time of Noah's ark down to the battle of Antietam—all of them, either staring right in your face as if they were suffering the last pangs of martyrdom, or as if straining a smirk whilst bitten by a flea. Family consanguinity in the present age of the world is circular—it has no limits—it is ubiquitous. Cousin Victoria, uncle Napoleon, great uncle Maximilian Joseph Ludwig, second cousin President Lincoln, nephew Colonel Ellsworth, my most intimate friend Lord Palmerston, General Beauregard, a distant relation of my wife's family (who is of French descent), General Kirby Smith (whose sister is a very dear friend of the family), Secretary Seward (the uncle of a lovely rich widow, now in Europe, on a tour with her medical adviser, for the benefit of her health and for her consolation after her heart-rending privations, and with whose little boys my dear little Joseph used to play at hide and seek in the Park)—together with an innumerable host of plebeian relatives and acquaintances, being part and parcel of our family pedigree: these, sir, you will find in our album on the drawing-room table.

This card picture is no ordinary picture; it is an extraordinary picture, and I will now tell you all about its manufacture.

The cards on which the prints are mounted, and which are denominated the "mounts," are each four inches long by two inches and one-third wide; these mounts can be had ready prepared, plain or ornamented with a gilt border, at the photographic ware establishments, whose advertisements you will find in this journal. The prints are smaller than the cards, leaving a margin of about one-tenth of an inch on the two sides and on the top; the margin at the bottom is about a quarter of an inch. The paper on which such pictures are printed is of the finest albumenized quality, that is, the texture of the paper itself is homogeneous and free from asperities, and the albumen is communicated to the surface uniformly and free from flaws. Some persons prefer plain salted paper for such pictures; but it is not advisable to make it your practice to print on such paper for such purposes, because you cannot obtain the same fine definition on a paper surface as can be obtained on an albumen surface. The prints in question present the model without inversion, being the result of solar printing beneath a negative. My task, therefore, resolves itself into that of taking a negative on glass.

Glass for negatives must be flat, homogeneous, free from flaws, and as transparent as possible; for card pictures it is cut to the quarter-size. The edges of each piece are ground, and the glass itself is prepared for the reception of the collodion, and in like manner sensitized, as already explained in a former lesson.

The developer may be either protosulphate of iron or pyrogallie acid. I do not use the same developer for negatives and positives. It is preferable to have less of the iron salt, in comparison with water, for a negative than for a positive, in order that you may watch the progress of the development easily, and also in order that you may flow the place entirely before the development commences. I use for my

Negative Developer.

Protosulphate of iron (pure)	40 grains
Water	4 ounces
Alcohol	2 drachms
Acetic acid	3 drachms

Or, No. 1.

Pyrogallie acid	12 grains
Acetic acid	1 ounce

(To be kept in the dark-room).

No. 2.

No. 1	1 drachm
Water	7 drachms
Alcohol	20 drops

(To be used immediately.)

* PHOTOGRAPHIC NEWS, vol. v. page 303.

† From *Humphrey's Journal*.

It is always recommended to filter both these developers before use. But, before we proceed to develop a picture, we must have the negative, and know all about taking it, and something of its philosophy. Instruction on these two points will form the subject of my next lesson.

The International Exhibition.

REPORT OF THE JURY ON PHOTOGRAPHY AND PHOTOGRAPHIC APPARATUS.*

FRANCE.

1458 BERTAUD (Medal).

1458 DEROGY (Medal).—To both of these exhibitors in the French department Medals were awarded. The first named received the award for an orthoscopic lens of very large diameter and excellent quality.

The lenses of Derozy were fully tested by the Jury, and proved highly satisfactory. An ingenious arrangement for lengthening and shortening the focus of the objective by the addition of a central lens, was found to answer admirably well for the purpose to which it was intended.

1459 BERTSCH, A. (Medal).—A Medal was awarded for a series of novelties in photographic apparatus. These consist of several automatic cameras with portable laboratory to facilitate the working of wet collodion out of doors without the necessity of a dark tent; also for a very excellent enlarging apparatus which he styles a "mégascope héliographe," the utility of which is illustrated by a variety of fine pictures enlarged from very small negatives. The collodion of this manufacturer is very good.

1457 DUBOSCQ, L. J. (Medal).—The apparatus for which a Medal was awarded in this instance, consisted for the appliances for using the electric light to photographic purposes, and a source of illumination for enlargement of pictures. It is stated that the specimens by NEMA-BLANC (1494) and VILLETTE (1456) were produced by means of this apparatus.

1451 TITUS-ALBITES (H. M.).—A manipulating laboratory camera, by which all the collodion process may be worked without any dark room or tent. The principle is similar to that of the original Archer's camera, but modified as regards the arrangements, which are very ingenious and deserving much commendation.

1476 BRIGIS, C. A. (H. M.). 1486 GARIN and Co. (H. M.). 1475 PUECH, L. (H. M.). 1493 MATHIEU-PLESSY (H. M.).

Honourable mention was granted to these exhibitors for general excellence of the various photographic materials which they exhibited, consisting of apparatus, photographic papers and chemicals. In reference to the chemicals, they deserve especial attention from the purity of the samples, as well as for the moderate price at which they are vended.

1490 HERRAGIS (H. M.) contributes a good assortment of lenses and photographic apparatus. His lenses have for a long time justly held a high reputation in France.

1482 KOCH (H. M.). This exhibitor is held in high estimation by his own countrymen, and the award is for general excellence of his apparatus.

1474 MARION (H. M.) contributes a variety of articles appertaining to the stationery of photography, consisting of albumenized paper, cases for preserving sensitive paper, albums, &c. These were all considered of great excellence.

1489 MILLET, A. (H. M.).—A variety of photographic lenses and fine pictures obtained by their aid are considered by the Jury well worthy of attention.

1473 ROLLOY (H. M.) exhibits a variety of good photographic chemicals and papers, also a varnish which, on trial, appeared to the Jury to possess many of the excellent qualities of the Söhne varnish.

36 KÜSS, A. (Medal).

HAMBURG.

PRUSSIA.

1420 BUSCH, E. (Medal).—Both contribute lenses for photographic purposes, which, on trial, were found to combine many excellent qualities in an eminent degree, and some were, moreover, distinguished by great cheapness.

1433 SCHERINGE (Medal).—The photographic chemicals of this exhibitor are well worthy of attention; they appear to be prepared with great care, chiefly for the supply of the retail houses. When purchased in any quantity these productions are very cheap.

1419 BEYRICH, F. (H. M.).—1427 KENZMANN (H. M.).

They exhibit many very fine samples of photographic papers, albumenized and plain. Results of a trial of several samples were very satisfactory, the proofs obtained being brilliant and perfect.

PICTURES.

We have already seen that great strides have been made in photography in the superiority of its processes; in the increased certainty which has been obtained by regard to the chemical condition upon which success depends; in the improvement of its apparatus, and the widened scope of its appliances, aided by increased skill in the manipulatory details. We now proceed briefly to refer to some of the examples of the various applications in which this progress was strikingly manifest.

Portraiture, as the most universal branch of the art, claims first attention; and here, in pure untouched photography, requiring no aid from the pencil of the artist, the most striking advancement has been made. Pre-eminent in this style are the vignette portraits of T. R. WILLIAMS (United Kingdom, 3182), to whom a Medal was awarded. In these, by the judicious arrangement of light, exact chemical conditions, skilful manipulation, and artistic management, a delicacy and perfection of representation is attained which at one time would have been regarded as impossible without the after touching of the pencil. Possessing many of the same qualities, combined with a richness and depth of tone due to the mode of printing, known as the ammonio-nitrate process, are the portraits by T. H. FLEMMING (United Kingdom, 3093). Similar in quality and in many points of excellence, but of larger size and bolder style, may be mentioned the portraits of M. Ken,

(France, 1500). In all these and some others delicacy is combined with great brilliancy, and those qualities which painters obtain by elaborate finish, are here secured by skilful manipulation guided by artistic judgment.

Another order of excellence, in which bold artistic conception is manifested with less attention to delicacy of manipulation, is illustrated by the productions of D. O. HILL (United Kingdom, 3996), whose portrait groups possess great merit.

The portraits of Ross and Thomson (United Kingdom, 3148) possess much of the freshness of design, and demonstrate that photographic portraiture need not be confined to the production of lifeless facial diagrams.

Untouched photographic portraiture, possessing many excellent qualities, both artistic and manipulatory, is exhibited by M. ALOPHE (France, 1462), and by M. NADAR (France, 1498), some of whose impressions have the additional interest of having been printed by means of the electric light.

M. ANGIEA of Vienna (Austria, 670,) exhibited a series of very large portraits, in groups, vigorous, brilliant, and artistic; they illustrate the fact, that the highest qualities are not incompatible with an amplitude of size not usually attempted in photographic portraiture.

K. STRAEGLE (Denmark, 133) contributes many portraits of similar excellence to those described; one possessing especial interest at the present moment in the eyes of the nation is a portrait of the Princess of Denmark, in which the charms of the photograph are much enhanced by the beauty, grace, and intelligence which it so faithfully depicts.

(To be continued.)

Correspondence.

FOREIGN SCIENCE.

[FROM OUR SPECIAL CORRESPONDENT.]

Paris, 11th March, 1863.

MESSIEURS DAVANNE and GIRARD have undertaken a series of researches upon the fixing of proofs by means of sulphocyanide of ammonium, as proposed by M. Meynier. They first tried its action upon albuminate of silver, and found that it was much more energetic as a fixing agent than hyposulphite of soda. If a certain quantity of albumen be precipitated directly by nitrate of silver, and after the precipitate is washed, and treated two or three successive times by sulphocyanide of ammonium, the residue carefully washed, we recognise that this residue dried and be calcined leaves only very minute quantities of silver in the ashes, while, in operating in a similar manner with hyposulphite of soda, the ashes contain, relatively, considerable quantities of silver. The sulphocyanide of ammonium appears, therefore, to present a real superiority over hyposulphite of soda in respect to the absolute fixing of the whites of the proofs.

Sulphocyanide of ammonium can be made to replace cyanide of potassium and hyposulphite of soda in all their applications. It dissolves, with the greatest facility, all the salts of silver employed in photography: chloride, bromide, iodide, &c. In the state of concentrated solution it fixes negatives very rapidly, and employed of the strength of 15 to 18 per cent. of water, it serves to fix positives.

It is a substance which readily crystallizes in fine white deliquescent crystals. M. Meynier can obtain it in very considerable quantities in his manufacture of ammoniacal salts, and the recent discovery by M. Gelis allows us to assume that this salt may be manufactured at as low a price as hyposulphite of soda. It presents the advantage over the latter of being less easily decomposed, and while the slightest trace of acid puts the sulphur of the hyposulphite of soda at liberty, and compromises the proofs, there need be no such fears in employing sulphocyanhydrate of ammonium. It is, therefore, a substance which merits the attention of photographers; it must be carefully studied, and although the first laboratory experiments appear to have been perfectly successful, yet long and extensive practice may show some inconveniences attending its adoption, but among its known advantages we may place in the first rank that of allowing the operator to handle indifferently negatives and positives, fixing baths, &c., without incurring stains or any other risk.

S. M. the Emperor has bestowed the cross of the Legion of Honour upon three photographers whose productions were most deserving attention in the late Universal Exhibition, viz., M. Bayard, for useful photographic inventions, M. Duboscq, for improvements in optical instruments, and on M. Poitevin, for his inventions in carbon printing and in photolithography.

* Continued from p. 119.

M. Beaujout suggests the following, in connection with printing enlarged positives, not as a new discovery in photography, but as a new application of a phenomenon lately described by Dr. Sabatier, with regard to direct positives on glass. Every photographer knows how difficult it is to obtain a perfect positive, either in the camera or by direct contact from a negative intended for enlarging: they also know how difficult and tedious it is to take enlarged positives from a small negative, the sky being so rarely clear. We avoid all these inconveniences by applying Dr. Sabatier's discovery.

Take an enlarged positive on wet collodion from the negative (the exposure is instantaneous in the sun), and develop it with pyrogallie acid, and, in causing diffused light to act upon it at a given moment, the enlarged positive may be converted into an excellent negative, by means of which as many positives may be obtained as required.

M. Davanne, in quoting Mr. Kibble's method of obtaining nitrate of silver, remarks that an analogous result may be obtained by keeping the nitrate of silver fused at a dull red heat for several minutes, a slight decomposition takes place; a part of the nitrate of silver probably passes to the state of nitrite, and another part is reduced to a very finely-divided metallic state; by afterwards making a warm solution we may rapidly obtain the reaction indicated by Mr. Kibble.

M. Licsegang remarks upon intensifying, that when the negative is completely developed by the dilute solution of sulphate of protoxide of iron, then washed, it is immersed in a bath containing 2 parts of cyanide of potassium, 0.4 of nitrate of silver, and 100 of distilled water. The picture fixed in this solution is carefully washed and intensified by the following process:—

In a litre of water dissolve 9 grammes of bichloride of mercury, and when the solution is complete add 25 grammes of iodide of potassium, pulverised. Shake until completely dissolved, then filter and keep for use.

When it is desired to intensify a proof, a small quantity of this solution is put into a glass, and thrice its volume of water added to it, and poured on and off the proof several times; and when the desired intensity is obtained, it is thrown away and replaced by a solution of hyposulphite of soda of 10 per cent., which gives both a deep tone to the proof and fixes it at the same time.

IRON DEVELOPMENT FOR DRY PLATES.

SIR,—Having found the mode of developing dry plates by means of pyrogallie acid without the addition of acid or silver, very successful, I thought that an iron developer applied in the same manner would produce a like effect. On trial I found that such was the case, the picture developing rapidly and evenly. When the image is fully out, the plate must be well washed and intensified in the usual way, with pyro and silver. The iron developer may be about 20 grains of the sulphate to the ounce of distilled water, *without any acid*.

Lime water will develop tannin pictures. The best way of using it is to immerse the plate in a bath containing the lime water. A mixture of lime water and tannin will also develop pictures taken by the Fothergill and other dry processes.—Your obedient servant, THOMAS M. LEAHY.

Dublin, 4th March, 1863

PANORAMIC PHOTOGRAPHS ON FLAT PLATES.

SIR,—In the last number of the NEWS, mention is made of some panoramic negatives on flat plates, exhibited at the late meeting of the London Photographic Society, and, as the subject appears to be at present attracting considerable attention, you will perhaps be able to find space for an account of the method by which I succeeded in producing such pictures, rather more than a year ago.

If an ordinary camera have a screen of pasteboard, or other opaque material, with a vertical slit about half an inch

wide down the middle, fitted inside the back of it, just in advance of the focussing screen, and be then directed at any convenient objects, and slowly turned on its stand, it will be seen that the view will appear to pass slowly across the narrow portion of the focussing screen, on which alone it can fall, with the vertical lines absolutely upright, and that the vertical dimension of the field will be the diameter of the circle of light given by the lens.

If now, by any contrivance, a sensitive plate can be caused to move in the same direction as the view appears to move on the focussing screen, and at precisely the same rate, it is evident that we shall be able to obtain a picture whose vertical angular extent is the angular diameter of the field of the lens, and of any horizontal length we please, this being limited only by the length of the plate.

This I have managed to effect in several ways, the simplest and most beautiful of which I proceed to describe.

An ordinary camera, furnished with a short focus lens (a Dallmeyer's stereoscopic would answer admirably), whose equivalent focus must be known with extreme accuracy, has the ordinary groove for its slides removed, and the end filled up with two pieces of wood, so as to leave only a narrow vertical opening between them down the centre of the field.

A back to hold the plate must be constructed like an ordinary stereoscopic back, but of a size to suit the dimensions of the picture to be taken, and with a shutter to work horizontally a little more than *twice* the length of the slide.

A vertical opening corresponding in dimensions with the opening in the back of the camera is made in this shutter across its middle; and on the sides of this opening are fixed two projecting slips of wood, which enable the shutter to be firmly fixed to the camera by biting the edges of the slit, precisely as the sides of the ordinary camera back slide into the groove in the camera. The shutter being thus fixed to the camera, it is evident that every part of the plate can, by sliding the frame along the shutter, be brought successively opposite the opening in the back of the camera.

A circular disc of well-seasoned wood or metal, is now to be made, with a shallow groove round its outer edge, the *radius* of the disc being made *exactly equal to the focal length of the lens*; this is the point of most importance in the whole contrivance, as any error here will prevent us from obtaining perfectly sharp pictures. This disc is to be fixed firmly on the head of the tripod and carefully levelled, and in the centre of the disc, and exactly concentric with its edge, must be a vertical proof made to fit into a socket in the bottom of the camera, so that when the camera is mounted on the disc, and turned round about the vertical axis of the pivot, the axis of rotation shall pass through the optical centre of the lens, and the axis of the lens shall be truly horizontal.

At one portion of the circumference of this disc, is to be attached one end of a very fine and flexible wire, somewhat longer than the plate frame, and the other end of this wire is to be fastened to a short arm, which is firmly fixed to the plate-frame, so that as the camera is turned round on the disc, the wire wraps round the outer edge of the disc in the shallow groove, and by this action causes the plate-frame to slide along the shutter at precisely the same rate as the image formed by the lens moves. If, therefore, a sensitive plate be placed in the plate-frame, taking care to slide the frame to one end of the shutter before bringing it out to the light, and the frame and shutter fitted on to the camera, and the wire attached, by simply causing the camera to revolve on its pivot slowly and uniformly, the successive portions of the view will be unwrapped and straightened out as it were on the flat plate, and if the opening at the back of the camera be not too wide (about one-tenth of the focal length for single lenses), a panoramic picture will be produced, of exquisite sharpness and beauty, and a perfect cylindrical projection of the scene, equal in accuracy, and vastly more useful to artists and military engineers than the queer looking catharine wheels produced by Chevallier's Plane Table.

I have left some minor points of detail unexplained, but the above is as brief and intelligible as I could make it without diagrams, and I shall be happy to give you any further information on the subject, if you think it sufficiently interesting to your readers, and to send you a specimen of the work it will do.

I forgot to mention, that by modifying the shape of the opening, a longer or shorter exposure can be given to any portion of the picture lying in a horizontal direction.—I have the honour to be, &c., &c.,
W. G. T. P.

[We shall be glad to learn further particulars, and to see a specimen of the results.—Ed.]

IODIDES AND BROMIDES IN COLLODION.*

An acetic acid bath is, in its first stage of sensitiveness, not appreciably, if at all, inferior to a nitric acid bath with ripe bromo-iodized or iodized collodion, but it is less stable than the nitric acid bath, and, eventually, capricious. It deteriorates much sooner, and is not easily rectifiable.

An acetate of soda bath, in its best state, is an accelerator of collodion, however iodized or bromo-iodized, but it is very capricious and rapidly deteriorates. I do not know how to rectify it.

A carbonate of soda bath is a superior accelerator, but it also is unstable like the last. In its sensitive state, however, it is well fitted for instantaneous work with ripe iodized or bromo-iodized collodion, and for iron development. The collodion being made of the ammonium and cadmium salts.

I beg to observe here, that when I talk of iodized collodion, I invariably mean, iodized with combinations of cadmium and ammonium, or cadmium and potassium; and when I allude to potassium, or ammonium, or cadmium iodizers, I always name them, and this will now prevent a misapprehension of my meaning.

Mr. Ponting, I see, holds the same opinion that you do—that a nitric acid bath is fatal to iodized collodion. A reference to his experiments will clearly show that he used $\frac{1}{2}$ drop of nitric acid to each ounce of bath. An excess of acid will, as is well known, diminish sensitiveness, and otherwise cause injury. And if Mr. Ponting's iodizer was ripe, the $\frac{1}{2}$ drop of acid per ounce was too much; for ripe collodion containing cadmium, as his does, works in a bath verging on neutrality.

Mr. Ponting's acetic acid and soda baths were but faintly or appropriately acid, and consequently the iodizer answered better with them. "The bath No. 1, with acetic acid and acetate of soda, was unmistakably the quickest of the three, the nitric acid bath, No. 2, being very slow."

If it is asked how this nitric acid bath, unsuited to the iodizer because of excess of acid, answered for the bromo-iodizers? I beg to reply that not one of the bromo-iodizers was constituted like the iodizer. There was no equality of conditions. Like Mr. Blanchard, Mr. Ponting made but one solitary experiment, and may or may not have pitched upon each collodion in its most serviceable condition.

If I can get heard, I feel convinced that the results of my experiments will be well received. I have no object in misleading any one, I have honestly stated all the conditions of my experiments, and challenge their all-possible fairness being disputed.

As illustrative of my experiments, let me recommend the following to any one desirous of testing them. Take a collodion of reliable quality from a good maker; iodize it with cadmium 3 grains, ammonium $1\frac{1}{2}$ to 2 grains; and for a bromo-iodizer, cadmium 3 grains, ammonium $\frac{1}{2}$ to 1 grain, bromide of ammonium 1 to $1\frac{1}{2}$ grain. Try these with a nitric acid bath, and acetate of iron developer, from time to time, and record the results; one subject, one lens, and one hour for both samples being understood. When the bath does not work satisfactorily, make a new one. Continue the experiments until the collodions begin to deteriorate. A comparison of the recorded results will show greater durability and sensitiveness in the iodizer. Other experiments may be made with different proportions of salts, and by reducing or increasing the quantity of bromide. The results will be as those stated under the heads A to D in my last letter, and I earnestly beg that they may not be considered untrustworthy until practically proved to be so.

I will conclude here with a hint regarding the nitric acid

bath. It must always be rectified for the bromo-iodizer, and it will then answer equally as well for its pair the iodizer. If the bath were rectified for the iodizer, precaution would perhaps not always prevent a possible excess to the hurt of the bromo-iodizer, especially if the quantity of bromide present is large, when this would, of itself, be a weakener and retarder of sensitiveness in a very marked manner. Taking the bromo-iodizer, then, as a regulator and key of the bath, is not wrong, nor need the plan create any apprehension of a possible deficiency of acid for the iodizer; for, with any given collodion, however so salted, it is not easy to ascertain exactly what quantity of nitric acid can exist in excess, or be deficient in a bath without appreciable injury to a plate; and this fact meets also the case of any accidental deficiency or excess in rectifying the bath at starting for the bromo-iodizer. And, above all, when we reflect that the pair iodizer and bromo-iodizer, to be compared, are of absolutely identical constitution in the plain collodion used, and in the proportions and bases of the salts used; and that ripe collodions, whether iodized or bromo-iodized, work in a bath verging on neutrality, the condition of the bath is, to all practical considerations, if not theoretical also, admirably adapted to both the iodizer and bromo-iodizer compared. If the correctness of these principles is concurred in, let them be compared with those adopted by Messrs. Ponting and Blanchard in the treatment of their baths for iodizers and bromo-iodizers not similarly and identically constituted.

I will not here recapitulate the articles of my belief. They can be seen under the heads A to D of my last letter; but I will only add that I nowhere condemn the use of bromides, regarding which, in page 479 of the PHOTOGRAPHIC NEWS, will be found the following.—"But although the use of a bromide is attended with loss of sensitiveness, the more appreciable as the quantity is larger, compared with simply iodized collodion, yet its presence in collodion is very desirable, because of its established sensibility to coloured light; and it simply remains for operators to regulate the quantity according to requirements, remembering that there is scarcely a subject which will not benefit by its presence in suitable strength. Of course the iron developer must be used."

By iodized collodion, here, is meant collodion iodized with combinations identically as the corresponding bromo-iodizers compared with it. And I would also recommend the perusal of my remarks at the beginning of col. 2, page 479, regarding the exquisite sensitiveness of chemicals when even a large addition of bromide is not accompanied by any appreciable loss of sensitiveness.

I think it is quite clear that I too swear by iron and bromo-iodizers, under certain qualifications, however, which but require examination to secure concurrence and general approval.

I am sorry that I should take up your time and space; but it is for the last time (if you so wish it). It is impossible to dispose of the present subject in a few lines. It has so many apparently contradictory features, that they defy collective treatment. The popular theory involved has hitherto been eluded and confounded with the popular practice. The former, which has never had a leg to stand on, has been sustained by arguments erroneously deduced from the latter.

I am not putting this question of iodides and bromo-iodides in a new light, but in one in which it has never before been properly viewed. I must meet with opposition from all those who have not been accustomed so to look at the matter. It is not possible to expect a cradle-faith to be abandoned without a struggle, unless, indeed, the principle of Mahomedanism is brought to bear on it; but this will not do with photography.

There should be no alarm at my efforts because directed against a pet, but unquestionably erroneous and untenable, theory, which most photographers have never examined, but been content to receive as correct, viz., that bromides are accelerators. They are, indeed, the very reverse, and answer successfully and admirably as drags. I am not singular in this view, and I have given proof enough to be tested by everybody. Mr. Hardwich, with a mind singularly free from prejudice, has pronounced bromides retarders; but he nowhere objects to their use—on the contrary, he recommends them, although retarders. I, also, have advocated their use. But while I uphold the practice proper, I attack the theory popularly expressed. And why should not error be exposed?—I am, dear sir, yours truly,
AUGUSTUS WEBB.

* Concluded from page 117.

Talk in the Studio.

PHOTOGRAPHIC PIRACY.—On the 4th inst., at Clerkenwell Police Court, *William Luff*, a photographic artist, residing at 325, City Road, was summoned before Mr. Barker, at the instance of Mr. Ferdinand Joubert, to answer the following complaint: "For that you, on the 17th day of January, not being the proprietor of copyright in a certain photograph, to wit of a photograph of H.R.H. the Prince of Wales, did unlawfully sell and offer for sale a copy or colourable imitation of the said photograph, without the consent of the said Ferdinand Joubert, the proprietor of the subsisting copyright in such photograph, and knowing that the said copy of such photograph had been unlawfully made contrary to the statute," &c. A gentleman from the office of Mr. Bowen May, solicitor for the prosecutor, said it was not intended to proceed with the case, as the defendant had signed the following declaration: "Mr. Joubert,—In consideration of your releasing me from the payment of any but 40s. damages towards the expenses of my solicitor, I promise never to offend again by selling any more printed copies of your photographs, and, if I break this engagement, I promise to pay you fifty pounds, by way of liquidated damages; and I declare I am not aware where I purchased the printed copies of the distinguished persons I have copied; and I also declare that I have no other copies than those handed to your solicitor, WILLIAM LUFF. Witness, J. Bowen May, 67, Russell-square."

PHOTOGRAPHY AND THE ROYAL WEDDING.—Public celebrations in our day are perpetuated by an unerring recorder which the grandest pageants of olden times lacked. Photography is the sworn witness of all public spectacles, and has been very active in all the recent public ceremonials. Many scores of brass tubes took aim at the youthful and fair Dane, who having before invaded many loyal hearts, came on Saturday to take possession of her conquest. Mr. Francis Bedford and Mr. Downes were at Gravesend to photograph the arrival; Mr. Blanchard took some instantaneous stereo negatives of the same ceremony. Many others were engaged in London, with what success we have not heard. The ubiquitous photographer even found his way into St. George's Chapel, at Windsor, to record the wedding ceremony, Mr. Vernon Heath having, we believe, been honoured with that commission. Not least attractive amongst the many tastefully decorated buildings in the city on Saturday was the Photographic Warehouse of Messrs. Henry Squire and Co., in King William Street, the noble circular front of the building having a fine balcony erected and ornamented with great taste. The warehouse was for the nonce turned into a theatre, with tier above tier of seats, accommodating a hundred persons with a most excellent view of the procession. Mr. Squire had issued photographic tickets, containing portraits of the Prince and Princess, inviting a large number of friends connected with literature, photography, and art, to witness the spectacle. When it had passed, it was announced that a successful instantaneous negative had been obtained from the top of the building, prints from which would be placed in the hand of each guest as a souvenir of the occasion. Of the other interesting parts of the entertainment offered to the guests, in which both wet and dry processes were tried, plates coated and cleaned with amazing rapidity, it is unnecessary to speak here. We need only add, having ourselves been present, that the results were most satisfactory. We learned, from the long examination which a pause in the procession afforded us opportunity for, that the numerous photographs which have crowded shop windows, have not done the young Princess anything like justice. Her fair hair, brilliantly rosy complexion, and the winning grace which lights up her delicate features of pure Scandinavian type, are not fairly rendered in any portrait we have seen.

To Correspondents.

G. F. R.—The first application of albumen and gelatine in combination with a bichromate for the purposes of photolithography of which we have any record was made by Mr. Osborne, who used it in 1859. The process is not protected by patent, and you may use it without let or hindrance. The fact that it is included in a patent by no means implies the validity of the patent. Nine-tenths of the photographic patents, indeed, a large proportion of the existing patents of all kinds, would be proved invalid if brought to the test of law.

H. L.—Unless the paper be good in itself it cannot give good results when albumenized. We have seen some samples of Saxe paper with streaks or

bands which were unusually absorbent, such paper would inevitably give imperfect results even when albumenized. In the case you describe another sample of paper is the only remedy.

J. W.—A yard only 20 feet by 15 feet in dimensions, surrounded by walls, the lowest of which is 15 feet high, is a rather unpromising place for photographic portraits. The only mode of preventing the undue action of top light will be to place a screen over-head, so that all light shall be cut off which does not reach the sitter at an angle of 45°.

S. M. Tou.—Your design for a colorless collodion bottle is doubtless ingenious, but as the sediment generally possesses a greater specific gravity than the collodion, it would be apt to flow from the bottom the moment the bottom of the bottle was elevated in the act of pouring.

Mr. Wright.—Vignette photographs are almost as old as photography itself, and were occasionally produced on the Daguerreotype plate before the collodion process was discovered. Mr. Harner has not, that we know of, made any claim for the invention of vignettes, nor even of the mode of double printing he has worked with such skill. The plan of double printing Mr. Harner unquestionably was the first to carry out to the same degree of perfection, but in its simpler forms it had been practised for many years. We must demur to the claim of priority or superior excellence you make for Mr. Watson, unless substantiated by proof.

S. W., Dudley.—In photographing engraved or cut-glass vessels you can get the same effects upon your plate which you can see with your own eyes; but if the vessels be transparent you can necessarily see through them to some extent, so that the cutting of the far side, as well as that which is nearest the eye will be seen. If you wish the front of each decanter only to be photographed, it will be necessary to cover or conceal by some means the other side. The best mode of lighting will be to place them at some distance from a window, so that the direct light reaching them may be tolerably well diffused, to give a soft light on one side and a soft shadow on the other. Use a bromo-iodized collodion, expose sufficiently long, and develop with iron.

A YOUNG PHOTO.—In making collodion, proceed in the following order, for, say 4 ounces:—Take 16 grains of soluble cotton, place them in your 4-ounce bottle, and add 1 ounce of alcohol, sp. gr. 820. Next take 8 grains of iodide of cadmium, 8 grains of iodide of ammonium, and 4 grains of bromide of cadmium; dissolve these in 1 ounce of alcohol of the strength before mentioned. When these are dissolved, filter the solution into the bottle containing the cotton and alcohol. Shake until the cotton is well saturated, then add 2 ounces of pure sulphuric ether; shake until all is dissolved. Then let the collodion stand for 24 hours, when it will probably be fit for use, and will be very sensitive. In making larger quantities, it is better not to add the iodizing solution until the normal collodion has been decanted from any sediment.

SUBSCRIBER T.—Acetate of soda is soluble in three parts of cold water; a saturated solution would consist, therefore, of one ounce in three ounces of water, a strength unnecessary in photographic operations. 2. Sulphuric acid which has become black has come in contact with organic matter; it may still be used for some purposes without disadvantage, but you cannot undertake to purify it. 3. Citric acid, when added to the printing bath to remove the colour, is used in no larger quantity than is just necessary to cause a slight precipitate, as, being tribasic, it rapidly wastes silver. 4. Sulphide of potassium added to a hypo bath for precipitating the silver is added until there is no further precipitate thrown down, the quantity necessary being determined by the amount of silver present. 5. Bicarbonate of soda is soluble in ten parts of water, therefore, 3 drachms will require $4\frac{1}{2}$ ounces of water to dissolve all. 6. The same principle applies here; you attempt to dissolve a substance in less water than is necessary for its solution; phosphate of soda is soluble in 4 parts of water, and, therefore, 5 drachms would require at least 2 $\frac{1}{2}$ ounces of water to dissolve all, whilst you have only used 2 ounces. 7. Sulphide of potassium is used to precipitate the gold from a hypo bath; protosulphate of iron from an alkaline toning bath.

NOTTING HILL PHOTOGRAPHERS.—We always feel pleasure in advocating the interests of every class of photographic operatives; but we must remind our readers that the bargain between employers and employed, whether it refer to the hours of labour, the work done, or remuneration received, is entirely a personal question between the parties to the contract. We strongly recommend liberality to employers as good policy, and because photography is generally sufficiently remunerative to justify liberality. But on the other hand it should be borne in mind that in winter a photographer's working hours are necessarily short, and that no available light should be wasted in summer. We do not think there is much danger of over-work or under pay in the present state of the profession, inasmuch as the market is not so much stocked with thoroughly skilled workmen to induce any of them to accept injustice. Where there is a good demand for any class of labour it will always command a fair price for reasonable hours. An employer who, under such circumstances, attempted to grind his people would soon find them leaving him for more liberal employers. Whatever grievance of this kind exists must soon right itself. We cannot offer a more definite opinion without knowing more of the circumstances, and hearing the case stated by both sides.

H. D. O'DONNELL.—The note and cash received. We will endeavour to carry out your wishes. Several Correspondents in our next.

Photographs Registered during the Past Week.

MESSRS. BEWLEY AND EVANS, 4, Lower Sackville Street, Dublin,

Photograph of Rev. Dr. Flcury.

MR. H. J. WHITLOCK, 11, New Street, Birmingham,

Three Portraits of Bishop Twells.

MR. SAMUEL WALTERS, 3, Filikner Crescent, Bootle, near Liverpool,

Photograph of the *Alabama*.

MR. MRS. VAISNER ET VEVEY, 31, Edgeware Road,

Stereoscopic View of the Edgeware Road on the 7th March, 1863,

entitled "Going to see the Procession."

All Letters, Works for Review, and other Communications for the Editor, should be addressed to the Office, 32, PATERNOSTER ROW, LONDON.

THE PHOTOGRAPHIC NEWS.

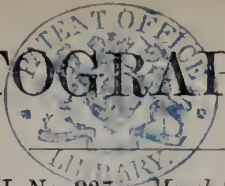

Vol. VII. No. 237.—March 20, 1863.

CONTENTS.

	PAGE
Enamelled and Tinted Papers for Photographers.....	133
A Final Word on Art-Photography and its Critics	134
English and French International Copyright in Photographs ...	134
Chemical Experiments. By John Kibble	136
Theory of Positive Printing, &c. By George Price	137
On the Electrical Theory of Photography. By John Johnstone	139

	PAGE
Proceedings of Societies	142
Photographic Notes and Queries	143
Photographs Registered during the Week	143
Talk in the Studio	144
To Correspondents.....	144

ENAMELLED AND TINTED PAPERS FOR PHOTOGRAPHERS.

It has often been said that a photographer needs to be a "Jack-of-all-trades;" it is probable that he will shortly have to add a knowledge of one more business to his miscellaneous stock of information: we refer to the trade of a fancy stationer. Tinted papers and enamelled papers are already in the market, and likely to command considerable attention, and we expect perforated cards, lace envelopes, and other specialities of the fancy stationer to follow.

Some of these things are really worthy of serious attention. We recently received from Herr Paul Liesegang a sample of paper, which, he informs us, is becoming popular amongst German photographers. It is called "enamelled paper," and is intended exclusively for card portraits, and similar small pictures. The surface very nearly resembles that of the well-known enamelled visiting card, which is generally produced by means of a preparation of lead. The instructions for manipulation are simply to proceed in all respects as with albumenized paper. We have printed a few card pictures upon the sample sent, following those instructions, and are highly gratified by the result. The paper appeared a little more sensitive than most samples of albumenized paper; printing rapidly with a rich red brown tone. They toned satisfactorily in an acetate of soda and gold bath a few days old, losing very little depth, either in toning or the subsequent fixing. We tried different tones, from a rich warm purple and a warm grey, to a deep fine black, free from any inkiness; in each case the colour being rich and deep, with a very agreeable warmth. The prints were, moreover, very brilliant, having both more vigour and more half-tone than some other prints from the same negatives on albumenized paper, the fine surface rendering with exquisite delicacy all the half-tone in the negative. There is, moreover, entire immunity from mealiness.

As to the mode of preparing this paper, we have no information, and can only speak from observation. The final surface appears to be chlorided albumen; but, instead of having been applied to a plain Saxe or Rive paper in the usual manner, the paper seems to have been varnished or enamelled in some way first, so that the albumen, instead of sinking into and partially permeating the paper, rests entirely on the surface; thus securing an important condition for brilliancy of image. If the paper be sponged or soaked in water before exciting, a surface of albumen can be removed, but an enamelled surface is found underneath. If an air bubble occur in exciting, the spot, after fixing and washing, is not plain paper, like that found under similar circumstances with albumenized paper, but still a varnished or enamelled surface. Of what the primary surface may consist, we cannot at present state; we can only remark, that it is insoluble in water and alcohol. So far as we can at present judge, it forms no combination with the silver during floating, and the image appears to be confined entirely to the surface of albumen; thus presenting a similar result to

the paper previously prepared with india-rubber. How far it may be equal to the latter we cannot say, as we have not made any comparative trial at present. Whether the paper is yet in the English market or not, we cannot state; but it will, doubtless, speedily find its way into the hands of dealers, and for card pictures is well deserving of a trial; for, whilst for large pictures we hold a glazed surface as vulgar and inartistic, for small delicate pictures like card portraits the objections are by no means necessarily the same.

Another kind of fancy paper for photographs has been attracting some attention lately. We refer to the rose-tinted albumenized paper. We must confess that we do not look with much favour upon its use. But tastes differ, and there are some subjects which may possibly be improved by the tint, especially if it be very delicate. Hard negatives sometimes also yield better results on a paper with a tint than on a pure white surface. Some other advantages are claimed for it, regarding which, however, we have had no experience. A correspondent writes to us, saying, that some tinted paper supplied by Mr. C. E. Elliott, gives him better results, and is more sensitive, excited on a forty-five-grain bath, than ordinary albumenized paper on an eighty-grain bath. The mere presence of colour could not, of course, effect the improvement, which must have been due therefore to other causes.

If a tint be desirable at all, it must be a much better plan to apply it after the completion of the printing operations, so that the exact character best suited to the print may then be easily determined. This will also remove a difficulty which we are informed in some cases occurs, namely, the disappearance of the colour during printing operations. We subjoin, therefore, a communication with which Mr. Lampray, of Paternoster Row, has obliged us, regarding his own experiences in the application of a tint to the finished picture. Here it is:—

DEAR SIR,—I have had a host of inquiries as to "tinted" paper and the practicability of tinting the picture *after* it is finished, instead of colouring the paper before it is albumenized. The information I have been able to give—the result of a few trifling experiments that I have made—seems to have afforded satisfaction to a good many of my correspondents. Perhaps you will not think some remarks upon the subject quite useless in your columns as others will thereby be enabled to avail themselves of what information I possess. The extremely little leisure left me by a daily and rapidly increasing business must be my excuse for the somewhat crude form of my communication.

I need scarcely say that it is manifestly an advantage, if tinted prints are desired, that the printer should have it in his power to tint them to any shade, and of any colour his fancy, or the necessity of the case, may dictate. He may, for instance, by adopting a suitable dye, tint his picture so as, in some fashion, to match the complexion of his sitter. This he could not do if he used paper tinted before printing, unless he had papers previously prepared not only of various colours but of different shades of each colour. And even then he could not be sure of obtaining the exact shade he desires, as a great deal of the

colouring matter comes out in the toning—and does his toning solution no good.

The plan I have tried is very simple, and any one can easily adopt it. The dyes I have used are known as "Judson's Simple Dyes," and may be had of any chemist, at sixpence per bottle. Six pennyworth would tint, I dare say, half a ream, or thereabouts, of paper. A little of the dye, according to the depth of tint desired, should be mixed in boiling water (stirring it up well with a glass rod), and the print should then be immersed in it for a few minutes. This should be done after the print has been fixed and *thoroughly washed*, and before it has been allowed to dry, otherwise it may make the paper rather rotten. Some colours get a little deeper on drying.

Some pictures I happened to have by me were toned to a peculiarly ugly colour. After tinting them in the way I have described, they were converted into very presentable, if not really good, prints. On an emergency, therefore, tinting in this way may be of great importance to the artist.

With care and a little practice, different parts of the picture may be tinted with different colours.

Hard, inky-looking prints improve by tinting.

A mauve tint gives a very good effect to landscape *stereos*.

I have produced one or two curious results in the course of my experiments, and on some future occasion, after further trials, I shall have great pleasure, should you accord me space, in laying them before your readers.—I am, dear sir, yours faithfully,

THOMAS LANPRAY.

44, Paternoster Row, London, E.C.
March 12th, 1863.

Judson's dyes are sold in small bottles at sixpence and upwards. There are several tints prepared, such as magenta mauve, scarlet, orange, blue, green, brown. A tea-spoonful of the dye added to a couple of quarts of boiling water will produce a tolerably vivid dye of any of the colours. For the rose tint, recently introduced in albumenized paper, the magenta dye answers admirably. The print, when completely washed and ready for drying, should be immersed in the dye and left for a few minutes. It should be borne in mind that the longer the immersion the deeper the tint becomes. A very dilute solution of the brown gives a fine india tint, which is, to our taste, the least vulgar of any colour for a picture, and may, indeed, in some cases, with advantage, take the place of white. In portraiture for instance, wherever a negative is hard, yielding black and white pictures only, a delicate india tint removes much of the effect of hardness, and is, in some cases, very pleasing. The mauve tint, or a mixture of mauve and magenta, will please some persons, and it is possible other mixtures may find a use. But there is one word of caution to which we beg especial attention; whatever the tint used, let it be as delicate as possible, or it will inevitably be offensive and vulgar. Let it be a tint and nothing more, never approaching a full hue. And bear in mind that the tints deepen very much in drying, they must not, therefore, approach the desired colour when wet, or they will be too dark when dry. It is not improbable that by skillful management these dyes might be used for tinting photographs in various colours, as they are perfectly transparent, but we do not enter into the subject at present.

Since writing the above, we see that Mr. Sutton has prepared a series of "Photographic Tints" to be used in a similar way for a similar purpose. He also adds another suggestion—to perfume the photograph. "Fancy," he says, "sending by letter your card portrait tinted and perfumed. Is not the idea exquisite?" Perfuming the photographs! Well, why not?

A FINAL WORD ON ART-PHOTOGRAPHY AND ITS CRITICS.

SOME weeks ago we gave a resumé of the opinions of the art-critics upon photography with a few brief comments on these opinions. Since then, our pages, and those of some of our contemporaries, have been considerably occupied by an amusing discussion on the subject, which has well nigh exhausted it. Mr. Rejlander has been quaint, humorous, modest, and forcible, in his defence of the claims of his art.

Mr. Wall has been trenchant and unsparing. Mr. Robinson has been terse and good-humouredly caustic. Others have spoken or written on the same side. The art-critics having done their business, we do not, of course, hear any more of them. Mr. Sutton has once or twice returned to the subject, but as we do not find him defending his original propositions, we conclude of course that he has abandoned them. We the more readily come to this conclusion because in his last number he treats the subject with infinite drollery. Referring to the authorities quoted by Mr. Wall to prove that truth was an important element in art, he says of a marble statue, "Why not have a little *more* truth, and paint it flesh colour, and put a wig of real hair upon its head, and give it glass eyes?" Now, when Mr. Sutton speaks of a wig and glass eyes as *truth*, he is of course joking; for have not these, from almost time immemorial, been regarded as typical of falsehood, and is not a wig commonly called *false hair*? Of course, Mr. Sutton is joking, and a good joke is often an excellent thing to aid in abandoning an untenable position. The truth is, Mr. Sutton has a real appreciation of art-photographs, and we have seen few photographs more artistic than some produced by himself.

There is just one point in the argument to which we will refer now. An important distinction we find continually overlooked in these discussions. It is customary with the opponents of the art claims of photography to confound *high art* with *fine art*, and because photography is unsuited to the one, to argue that it is incapable of the other. No one that we have ever known has claimed for photography the capability of competing with high or ideal art. Jokes about Michael Angelo or Raphael engaging in photography are therefore altogether beside the mark. No one ever dreams of expecting works of imagination from photography, and the most ardent art-photographer would as soon think of comparing one of Madame Tussaud's wax figures with the Moses of Michael Angelo, as of comparing the best photographs with Raphael's Transfiguration. But is there no fine art but ideal art? If so, what are the works of Landseer, Frith, Ansdell, Creswick, Stanfield, Hook, Linnell, Brett, McCullum, or a host of others whose especial charm is *truth* in the delineation of nature? To deny to photography a position amongst the fine arts because it is not ideal art is then clearly foolish, as by pushing the argument to extremes we must exclude by the same argument all the productions of artists whose pride and boast is to paint only from nature.

We do not intend, however, to enter into any further discussion here of a question which to us appears so self-evident: but before entirely leaving the subject, we should like to call the attention of our readers to a large engraving of Mr. Robinson's last composition "Bringing Home the May," which appears in the *Illustrated News* of the 28th ult., accompanied by some remarks reiterating the former criticism in that journal, protesting against the want of harmony in tone in photographs, and arguing that they cannot be in "any true sense pictures." Now we simply want our readers to mark the fact, that according to the canons of these critics the engraving before us is a work of art, whilst the photograph from which it is taken is not and cannot be. Yet we unhesitatingly challenge conclusions on these two pictures. The photograph is full of tone and gradation, the chiaroscuro is almost perfect and the whole is most harmonious. The engraving is as unlike as it is possible to be and at the same time be a copy. It is a crude, inharmonious mass of spotty lights and black shadows without gradation, tone, or harmony in any sense of the word. But this is art, and Mr. Robinson's original is photography.

ENGLISH AND FRENCH INTERNATIONAL COPYRIGHT IN PHOTOGRAPHS.

Few persons are aware that, although an original photograph be first published in the United Kingdom, the copyright in such photograph may now be secured in France,

and *vice versa*. As photography has grown into a branch of industry, and photographic copyrights are of considerable value, it may be useful to call attention to the existing state of the laws of England and of France affecting such copyrights.

Formerly, when any work of literature or of the fine arts was first published abroad, the copyright in it became public property in England. The author was unable to obtain any protection there in respect of such copyright. This manifest injustice has been remedied by certain Acts passed in the reign of Her present Majesty, "to amend the law relating to international copyright." These statutes enable the Crown, by order in Council, as respects works of literature, music, and art (to be defined in such order), and which shall be first published in any foreign country named in that order, to direct that the authors of such works, and their assigns, shall have the privilege of copyright therein to the same extent as allowed by law in respect of any such works first published in the United Kingdom. But no such order is to have any effect unless it states that due protection has been secured by the foreign power named in the order, for the benefit of parties interested in works first published in the British dominions similar to those comprised in such order. Besides this, as a condition precedent to the acquisition of any copyright in a work so first published abroad, the statutes render it imperative that the work shall be registered at Stationers' Hall, together with the date and place of first publication thereof abroad. The time within which such registration must be made after that first publication is to be fixed by the order in Council.

In 1852 an International Copyright Treaty was entered into between England and France, whereby it was agreed that "the authors of works of literature or of art, to which the laws of either of the two countries do now, or may hereafter, give the right of property or copyright, shall be entitled to exercise that right in the territories of the other of such countries for the same term, and to the same extent, as the authors of works of the same nature, if first published in such other country, would therein be entitled to exercise such right." But the treaty expressly stipulates that such international copyright shall not be claimable in either country, unless the work shall have been registered," viz. :— "1st. If the work be one that has first appeared in France, it must be registered at the Hall of the Company of Stationers in London; 2nd. If the work be one that has first appeared in the dominions of Her Britannic Majesty, it must be registered at the *Bureau de la Librairie* of the Minister of the Interior at Paris." At the time of such registration "one copy of the best edition, or in the best state," must also be deposited; and "in every case the formality of deposit and registration must be fulfilled *within three months after the first publication of the work in the other country*." The treaty likewise provides that "a certified copy of the entry in the register-book of the Company of Stationers in London shall confer within the British dominions the exclusive right of republication until a better right shall have been established by any other party before a court of justice;" and that "the certificate given under the laws of France proving the registration of any work in that country shall be valid for the same purpose throughout the territories of France." The charge for registration of a single work "shall not exceed one shilling in England, nor one franc twenty-five centimes in France; and the further charge for a certificate of such registration shall not exceed the sum of five shillings in England, and six francs and twenty-five centimes in France." The ten years' term for which this treaty was entered into has expired, but it provides that it shall continue in force "from year to year until the expiration of a year's notice from either party for its termination"—an event which in the present advanced state of public opinion respecting international rights generally, and copyright particularly, appears to be most improbable.

In pursuance of this treaty, and of the powers vested in the

Crown for that purpose, Her Majesty afterwards made an order in Council, whereby it was ordered "that from and after the 17th day of January, 1852, the authors, inventors, designers, engravers, and makers of any of the following works (that is to say), books, prints, articles of sculpture, dramatic works, musical compositions, and any other works of literature and the fine arts, in which the laws of Great Britain give to British subjects the privilege of copyright, and the executors, &c., of such authors, &c., shall, as respects works first published within the dominions of France after the 17th January, 1852, have the privilege of copyright therein for a period equal to the term of copyright which authors, &c., of the like works respectively first published in the United Kingdom are by law entitled to; provided such books, dramatic pieces, musical compositions, prints, articles of sculpture, or other works of art have been registered, and copies thereof have been delivered according to the requirements of the International Copyright Act (7 Vict. c. 12 s. 6) within three months after the first publication thereof in any part of the French dominions."

Soon after entering into the above convention the French law was placed upon what seems to us, having regard to the existing state of the law of nations, to be the only just, and, consequently, tenable ground respecting international copyright. Irrespective of any reciprocity, a decree was made upon the 28th March, 1852, prohibiting within the dominions of France the piracy of works published in any foreign State, and also the importation or exportation of any pirated copies of such works.

Now, with respect to copyright in *photographs*, no such copyright existed according to the law of England prior to the 29th July, 1862, when "The Copyright (Works of Art) Act" came into operation. Since that date the authors of original photographs, or the employers of such authors, are entitled to copyright therein *for the author's life and seven years after his death*; but to acquire the benefits of that statute, the work must be registered at Stationers' Hall.

So likewise, according to the decisions of the French Courts, no copyright in *photographs* has until recently been held to exist in France. According to the Code Napoléon, "*L'auteur d'un ouvrage de littérature ou de gravure, ou de toute autre production de l'esprit ou de génie qui appartient aux beaux-arts, en aura la propriété exclusive*"—or copyright, during the life of such author, also of his widow, and for thirty years after the death of the survivor of them in favour of their children.

Does a *photograph* come within the above definition of the French law relating to works of fine art? Some of the most eminent French artists have protested against the art of photography being deemed a fine art; and until within the last few months it seems that the French Courts were of the same opinion. But the decisions upon the point have recently been overruled by the supreme court of appeal in France, the Court of Cassation, in a case which arose out of the piracy of a photographic portrait of the late Count Cavour. It was held that although a mere servile copy of any subject made by means of photography is not absolutely a work of art within the meaning of the Code, yet that a photograph does become a work of art, and is the subject of copyright, when its execution includes artistic conception upon the part of the author.

Practically, therefore, British photographic artists will now be enabled to obtain the benefits of copyright in France for most of their original works. If claimed under the Copyright Convention with France, to which we have alluded, it will, however, be subject to the performance of these conditions: 1st. The work must have been first published in the United Kingdom. 2nd. It must have been registered, and a copy deposited, in Paris, *within three months* after such first publication.

Upon the other hand, it seems French photographic artists may now secure a British International Copyright in all their original photographs upon these conditions:—1st. The work must have been first published in France. 2nd. It

must have been registered, and a copy deposited, in London, within three months after such first publication.

Considering the beauty of, and the immense demand for, many photographic works produced both in France and England, the existing state of those international relations to which we have called attention seems calculated largely to enhance the value of original productions of that description by French and British artists.—*Athenæum*.

CHEMICAL EXPERIMENTS.

FORMATION OF NITRATE OF SILVER FROM AN IMPURE SOURCE, WITH SEPARATION OF IMPURITY; THE SAME FROM PURE SILVER, WITH PROOF OF THE ATOMIC THEORY.—PAPER RELATIVE TO THE ABOVE, COMPRISING GENERAL REMARKS ON THE SENSITIZING BATH.

By JOHN KIBBLE.*

In the present advanced stage of our Society, it will doubtless appear to many of you a retroceding, on my part, in entering into a subject with which all of you are supposed to be familiar. Such an opinion, to a certain extent, will really be correct; yet, from the numerous queries put to me by photographers and others, many practical difficulties must exist—not so much, perhaps, in the preparation of the new silver baths as in the reduction of the old solutions, which have become unfit for use by general deterioration, such as acidity, foreign matter getting admittance into it by some unknown means, or from any accidental cause whatever. I think it will best forward the object I have in view to commence with the preparation of nitrate of silver from an impure source, such as the silver alloy of commerce, which will not only show the formation of nitrate of silver, but the very simple manner in which the copper or any other impurity can be separated and a pure salt obtained, and, if desired for instantaneous work, brought to its greatest state of alkalinity by fusion.

Before doing so, I will enter into a few particulars regarding the tendency which all bodies have to combine in definite proportions with each other when entering into chemical union. So fixed and invariable is this, when all circumstances are alike, that the term "law" has been adopted to express the fact. The chemical atom must not for one instant be confounded with the atom of the philosopher, or that infinitesimal portion of matter supposed to be indivisible. The latter is purely imaginary, and, although affording a wide field for ingenious speculation, is of very little consequence to the present purpose; the former is an absolute fact, proved by gravitation, and visibly demonstrated through the medium of the finely-adjusted balance. Until such an instrument was resorted to, chemistry, that matter-of-fact science, had in it much that was hypothetical.

Oxygen—that body which plays so important a part in the economy of the universe in which we dwell—exists in combination with hydrogen in the proportion of eight of the former to one of the latter by weight, forming that well known and absolutely necessary fluid, water. Assuming the combining proportion or atom of hydrogen as unity, it necessarily follows, the atom of oxygen being eight times heavier than the former, when they enter into chemical union with each other the resulting atom of water must be nine. For example: take eight grains, by weight, of oxygen, one of hydrogen, and having ready a glass tube of the requisite capacity, sealed at one end, filled with water, place it on a shelf in the pneumatic trough, the open end a little below the line of the water. Having done so, pass into it the gases in the above proportions. Pass an electric spark through the tube: chemical union will at once take place, accompanied by detonation and light—simple manifestations of combination. The water from the trough will rush into this tube, filling it, showing that the gases no longer exist. Repeat this experiment, say with ten grains of oxygen to one grain

of hydrogen. Upon the electric spark being applied, the gases will again combine in their atomic proportions; but, in this instance, it will be observed that the water does not fill the tube, but leaves a space equivalent to the vacuum occupied by two grains of oxygen. Upon a quarter grain of hydrogen being added, and the electric spark applied, the water will rush into and fill the tube as in the first instance, proving the gases will only combine in the ratio of eight to one, or their atomic proportions; could they be forced to combine in any other proportions the result would be no longer water.

Let me now take the metal iron. If fifty-six grains of it in a very finely divided state, be enclosed in a bulb tube of the following shape, the exact weight of which is known



—having fixed it to some support so that the flame of a spirit lamp, or better still, if at command, a Bunsen's gas burner, can be applied to the bulb containing the iron until such time as the mass is ignited to redness—the flame of an additional lamp must now be applied to the flask containing water, attached, as you observe, to the end of the tube, until the water undergoes ebullition, keeping a continual stream of vapour passing over the red hot iron. The affinity of the metal for oxygen will cause decomposition of the vapour, the oxygen thereof uniting with the iron forming the peroxide: the released hydrogen passing off with the superfluity of vapour can be collected, if means be used for that purpose. Allow the glass vessel to cool, and, after ascertaining that there is no adhering moisture, the whole can be carefully weighed. It will now be found to have increased exactly twenty-four grains in weight; two atoms of oxygen which have attached themselves to the metal forming the peroxide of iron = eighty grains. This is in chemistry termed a synthetic experiment, or the formation of a compound from the elements of which it is composed. Now comes rather a paradoxical point. Detach the flask containing the water and add thereto some iron filings and a small quantity of sulphuric acid: replace it again: this, by the decomposition of water will yield hydrogen, which, as it passes over the heated oxide will rob it of the oxygen, the pure metal being left the same as at the starting point. This is called an analytical experiment, or the resolving of a compound into the elements of which it is composed—the exact converse of the former. This is an exceedingly interesting experiment. In the first instance, iron under the influence of heat decomposes the vapour of water, becoming itself an oxide, the hydrogen passing off free. In the second instance, the oxide of iron under heat parts with its oxygen to the hydrogen, the two gases combining to form water, the pure metal coming into existence once more. There is something very singular here. In the first experiment the iron tears the oxygen from the hydrogen: in the second, the hydrogen tears back the oxygen from the iron. This can only be explained by quantity; that is, the great volume of hydrogen passing over the heated oxide, every atom of which is struggling for its atom of oxygen, the joint force empowers the affinity existing between the metal and oxygen, which, in the act of splitting up, is seized upon by the hydrogen in atomic proportion—the result being water, the iron left pure. You will also observe that when these two gases are presented to each other in the nascent state—that is, immediately on being let loose from other combinations—they at once enter into chemical union; whereas, if collected in separate vessels and allowed to get into a state of repose, and then presented to each other, they will mix

* Read at a meeting of the Glasgow Photographic Association, March 5th, 1863.

mechanically, but not combine, unless other means are employed, such as a flame of the electric spark. May not this be analogous to what photographers experience with sensitive surfaces which are not developed within a given time after having been submitted to actinism? or with the iodide of silver surface which has been left too long in the nitrate of silver bath after decomposition has been thoroughly effected?

With the little I have said, unless you have yourselves practised such experiments, you must exercise faith. With what is to follow, that may be discarded: there stands the material, which you can test by gravitation.

For the first experiment I shall take the atom of silver = 108—in the *present instance* grains—which you must take as the standard of all that follows, unless contradicted.

When nitric acid— $\frac{1}{11}$ $\frac{5}{43}$ —is poured over this, decomposition of part of the acid ensues. Eight grains of its oxygen combine with 108 grains of silver, forming the oxide of silver, = 116, at *one and the same instant*: the oxide is dissolved in the free undecomposed portion of the acid, forming nitrate of silver in solution = 170 grains; that is, 54 acid, 116 oxide, of which you now have visual evidence. All the free acid being now evaporated, you have the nitrate as an amorphous mass. On the temperature increasing, you observe the mass enters into fusion, which, if carefully done will show a decidedly alkaline reaction with litmus paper. Having so far as I have proceeded given proof of the atomic theory, I will now dissolve the nitrate in distilled water, and give you an additional proof of what is termed substitution, viz., that the atom of one metal will displace from solution, the atom of another.

You are already aware that the present solution contains exactly 108 grains or the atom of silver. To displace that I use one atom of copper, = 32 grains. You now observe that having heated the solution, and kept the copper wire rotating in it, to shake off the adhering deposit of silver, already in the space of a few minutes all the metal is thrown down. I now withdraw it, pull it through the folds of a towel to clean it, and very slightly heat it to drive off moisture. It now weighs, as I anticipated, exactly 32 grains less than at first, = one atom of copper, which is now in combination with the acid formerly holding the silver in solution. The atom of copper can now be displaced by the atom of iron or zinc; but time does not admit of that, nor is it all necessary. It is imperative in experiments of this nature that no free acid be present in the nitrate solution, otherwise it will be a source of error in many ways. It would dissolve more than the atom of copper, and therefore could be called a case of substitution: even could the copper be withdrawn immediately all the silver had fallen, the free acid would again take the finely-divided silver into solution.

For the present I will lay aside the pure nitrate solution and commence with the impure, precipitating the silver therefrom by substitution. This will not only give a very correct idea of the quantity of alloy, but will show the separating, washing, and formation of pure nitrate of silver from an impure source, such as the photographer has often to deal with. In this part of my experiments I have to work at considerable disadvantage, the vessels being much too small to give the thorough washing and boiling necessary to deprive the silver precipitate of its adhering copper. I find in my own experience that silver precipitated from strong solutions is infinitely much worse to free from copper than when displaced from weak solution, and are apt to show traces of copper when re-formed into the nitrate of silver, even although the latter washings were alternately with weak acids and ammonia; but when separated from weak solution, and boiling water is used in washing, a very pure salt can be obtained—in as short a time, and with as little trouble, or less, than by any other mode I have tried—such as the chloride, carbonate, oxide, &c. I have a strong impression that silver in precipitating rapidly from strong solutions embodies in its substance traces of the nitrate of copper,

which only again get loose on the breaking up of the metal, such as in entering into solution; if so, the slower the precipitation the better. With a proper arrangement of the copper, a pound weight of silver could be thrown out of solution just as rapidly as one ounce, and with as little labour.

To iodize the bath, the simplest mode is to dissolve the crystals of the nitrate of silver in three or four parts of water, and add about fifteen grains of nitrate of silver to each ounce of the quantity weighed. This will immediately disappear. But in reducing the solution to the strength of thirty or forty grains per ounce fluid, a considerable precipitate of iodide of silver will be displaced from solution, showing over-saturation at that strength. This will also show that a bath, although saturated with iodide of silver at the strength the photographer works with, when used for long exposures, such as enlargements,—more especially if the temperature be high, the evaporation of water from the nitrate of silver covering the sensitized surface,—must, of necessity, increase it in strength—indeed sometimes to saturation, when it will at once attack the iodide, taking it into solution, thereby rendering the film porous, and round the edges of the plate almost transparent.

If there be any point which I have not lucidly expressed, or which you may consider erroneous, please to bring it under discussion.

THEORY OF POSITIVE PRINTING.—ALBUMENIZED PAPER AND THE ACTION OF THE SENSITIZING BATH.*

BY GEORGE PRICE.

THERE is what I consider to be *another fallacy* which requires a passing notice, the belief in which has prevented any endeavour to ascertain whether it be not possible to obtain different—or better—tones than we do at present: I mean the belief that the base of the salting chloride has no effect in giving colour to the print; that the nitrates produced from these bases *cannot* have any effect, may be according to a *pre-conceived* theory, but it will be very evident that *it is contrary to fact* to any one who will watch the different hues produced by ammonium, sodium, and barium, provided *they make use of their eyes*. I ask, then, would it not be advisable to ascertain whether there be no nitrates, the addition of which will yield purple, black, or rich brown tones, according as the subject might require. Evidently the belief in this fallacy arises from what I also consider to be an erroneous idea as to the manner in which the double decomposition takes place when the dried chlorided albumen is sensitized by the nitrate of silver bath. According to an assumed theory, when the decomposition of the salting chloride takes place, the chlorine remains in the albumen, drawing to itself the silver from the bath; whilst the liberated nitric acid and oxygen, being left behind by the silver, draw to themselves, *from the paper*, the base of the salting chloride which the chlorine has liberated in consequence of its own greater affinity for silver. The chloride of silver being, therefore, formed *in the albumen*, and the nitrate of ammonia, soda, or baryta, as the case may be, being formed *in the bath*. Stating it shortly, it is assumed that the *re-composition* of the *new chloride* takes place in the paper, and the *re-composition* of the *new nitrate* in the bath.

When theories are at variance with facts methinks it is time that they were abandoned and others formed more in accordance with the results which practice exhibits; but instead of doing so, so tenacious of life is a fallacy, that we find persons who, although unable to deny the facts, are compelled to confess that they are at a loss to account for their existence, because they still persist in viewing them through the medium of a *pre-conceived* theory. Thus, in the celebrated controversy which took place about two years ago, respecting "the testing of used silver baths by the hydrometer silver meter," Mr. Dawson, the present lecturer on photography at King's College, stated,† that "*theoretically* the large amount of other nitrates arising from the double decomposition, must *necessarily* accumu-

* Continued from p. 128.

† PHOTOGRAPHIC NEWS, vol. v. p. 116, and BRITISH JOURNAL OF PHOTOGRAPHY, vol. viii. p. 103.

late to such an extent as to render the hydrometer test useless;" and doubting the assertion "that such an accumulation did not *practically* take place, except to a very limited extent," he afterwards analyzed some old baths in order to satisfy his own mind on the point. Consequently, in a paper he subsequently read upon the subject, in allusion to one of these baths, he says*—"I should certainly have expected to find a very much larger proportion of nitrates different from that of silver. The equivalent of nitrate of soda being 84.97 (say 85), it follows that, for every two grains of nitrate of silver abstracted by decomposition, one grain of the former *ought* to be left in the bath. In the above case, certainly, and in some other baths I have tried, this accumulation of nitrate of soda or ammonia did not take place in any way commensurate with the quantity *we ought to expect*. Although these nitrates must inevitably be found, they are partly retained and taken away by the paper, *in a way which I am at a loss to account for.*"

Again, persons have assumed that the nitrate of the base of the salting chloride does not affect the colour of the print, and though an intelligent use of their eyes cannot fail to tell them the contrary, they still adhere to this idea, and endeavour to find *another cause* for the colouration which they cannot gainsay. Thus, Mr. Hardwich, in the last edition of his *Manual of Photographic Chemistry*, page 479, in speaking of chloride of barium, says:—"It also slightly alters the colour of the photographic image when used in preparing positive paper, which may be due, in some measure, to a chemical combination of baryta with albumen." That it is the *nitrate* of baryta which produces the alteration of colour, is evidenced, I think, by the fact that it takes place in a much greater degree in *plain salted* paper, than it does in albumenized; in *plain salted* paper the *black* colouring property of nitrate of baryta has not to contend against the *red* colouring of albumenate of silver, and no albumen being present, the peculiar colouration *cannot here be produced by its combination with baryta*. This theory of the nitrates of ammonia, soda, and baryta being formed in the bath, I believe to be based upon assumption, and *to be contrary to fact*. I maintain that the double decomposition and recombination takes place *on the surface of the paper*; the nitrate of silver solution leaves the vessel which contained it and adheres to the surface of the paper, permeating the film of dried chlorided albumen; I am therefore at a loss to conceive why theory should *grant* to the chloride of silver the privilege of being formed on the paper, where its constituents are present, but should *deny* the same privilege to the nitrate of ammonia, soda, and baryta, whose constituents are *also* present there. Whatever nitrates, otherwise than silver, are found in an old sensitizing bath for paper, I believe find their way there in consequence of a too long floating *having dissolved them out of the albumenized surface of the paper* where they had *originally* been formed.

The philosophy of positive printing upon albumenized paper is really such a comprehensive subject, that it would even be a vain attempt for any one with far greater abilities than I am possessed of, to endeavour to treat it satisfactorily in a paper which must necessarily be circumscribed in its length, in order to afford time for after discussion. I have, therefore, omitted *even an allusion* to those necessary accompaniments of printing—*toning and fixing*—and confined myself to the action of the preliminary sensitizing bath; for, had I not done so, I must have encroached *much more* upon your time and attention, and I fear that you may think it has been trespassed upon too much already; moreover, I deem that I have already furnished you with quite enough matter for an evening's discussion.

As a question naturally fixes attention to its own individual subject, allow me to state in that form, the various points which I consider particularly require elucidation, and upon which I invite your opinions:—1st. *What salting chloride* for the albumen is the best to use, and why? Also, is a combination preferable to a single one? if so, what, and why? and what proportion should the chloride bear to the albumen? 2nd. *How* does the nitrate of the base of the salting chloride influence the colour of the print? 3rd. *Supposing* the albumenized surface of the paper be capable of being rendered insoluble *previous to sensitizing*, would that insolubility be an advantage; or, would it not tend to diminish—or destroy—its capability of being sensitized by the nitrate of silver solution? 4th. *Supposing* we use a *very strong* sensitizing bath, is the vigour of the print dependent upon the length of time the albumenized paper is floated upon

it; and does its employment necessitate *deeper printing* than a weaker bath does? 5th. In sensitizing a sheet of albumenized paper, are *two separate and distinct* compounds of silver formed, viz., the albuminate and chloride; or, is a *double compound* formed? 6th. *Supposing* two distinct and separate compounds of silver be formed by sensitizing, which of the *three* compounds of silver on the paper is the most important in the production of the image—the albuminate, the chloride, or the nitrate? What part does *each* play—and do they act conjointly or independently?

I do not mention the opinions I have advanced respecting dried albumen, and the manner in which the double decomposition and recombination is effected when we sensitize a sheet of chlorided albumenized photographic paper, because they can be discussed incidentally with the points I have named.

In all philosophical discussions, but more especially when the subject is but little understood, mere *assertion* will never tend to enlighten us, however high an authority the person making it may be considered; for we have had too many instances of men of science being led into grievous error and promulgating most extraordinary fallacies as facts; every gentleman, therefore, who gives his opinion upon *any* points that arise in the discussion, will, I trust, state the *reasons* which induced him to form them, as he thereby gives the others an opportunity of showing whether they are fallacious or not. For the better elucidation of these points, I think I should be allowed the same privilege that counsel are, viz., that of *cross-examination*, which I will promise not to use rigorously. With this suggestion I now leave the subject in your hands to deal with in the manner you consider best.

ADDENDUM.

This, Mr. President and Gentlemen, is what I wrote for our last meeting, but its having been unavoidably postponed, a short addendum is now necessary. A paper has since been published in the journals, by M. Davanne and Girard, "On the Action of Nitrate of Silver upon Albumen,"¹² they state:—"The combination of albumen with nitrate of silver varies according to the strength of the silver bath. Thus in treating five cubic centimetres of albumen with five grammes of nitrate of silver, we obtained very different precipitates, according as those five grammes of silver were dissolved, so as to form solutions of 15, 10, 5, 2½, or 1 per cent. With the solutions of 15 and 10 per cent., the albumen is strongly coagulated; it gives a heavy, abundant precipitate, which may be collected on the filter in the form of distinctly separate pellicles. With weak solutions of silver, the quantity of the precipitate is much less considerable. A notable quantity of albumen remains in the bath in a state of solution. The portion precipitated is soft, glutinous, and sticky."

This is an announcement that every one who knows anything at all about the subject, has been fully aware of *long ago*. If an egg be boiled what we deem soft, the white has very little consistence, but this consistence increases up to the point at which the yolk becomes, by boiling, what we designate hard; the albumen is then, what, for want of a better expression, I will call *saturated with heat*, and thus is perfectly coagulated; it is only therefore to *this* state that the term coagulated properly applies. The same, also, with respect to the combination of albumen with nitrate of silver. Albumenate of silver is, correctly speaking, only that combination of albumen which takes place when it is *saturated with nitrate of silver*, every combination *below* this is what may be considered as an *imperfect albumenate*. Common sense tells us that, as varying approximations to perfect coagulation are afforded by varying degrees of heat, so differing proportions of nitrate of silver must produce differing approximations to the perfect albumenate of silver.

I am ever willing to confess that I have formed an erroneous idea, when that idea is proved to be incorrect. I have, therefore, now to state that I have hitherto been in doubt whether, if the albumenized surface of a sheet of photographic paper were rendered insoluble *previous to sensitizing*, this insolubility would not almost destroy its capability of being sensitized. This doubt is now dissipated, for Mr. Simpson has kindly furnished me with a piece of albumenized paper, the surface of which, Mr. Wood, of Edinburgh, has rendered insoluble by the aid of steam. This paper does not *appear* to have lost any of its capability of yielding either the albumenate or chloride of

* PHOTOGRAPHIC NEWS, vol. v. p. 116, and BRITISH JOURNAL OF PHOTOGRAPHY, vol. viii. p. 103.

* PHOTOGRAPHIC NEWS, vol. vii. page 53.

silver, by sensitizing. A comparatively weak nitrate bath will, of course, produce good effects upon it, provided it be of sufficient strength to saturate the albumen in the ordinary time of floating, as a strong bath is only necessary when the albumen is soluble, because by hastening the time when insolubility occurs, it prevents the solvent power of the water having full effect.

Ever since I have known anything of photography, I have been firmly convinced that the nitrates of the base of the salting chloride, affects the colour of the print; although this has been strongly denied, the belief that such is the case has been daily gaining ground, and in Mr. Towler's "Lessons on Photography," No. 11, published in *Humphrey's Journal*, I now find my statement corroborated. In allusion to plain and albumenized paper, prepared for photographic printing, he says:—"The chemical foundation in either, is an alkaline chloride, which by floating the paper on nitrate of silver, or ammonia nitrate of silver, becomes converted into chloride of silver, in a state of very fine division, mixed with the nitrate of the alkali employed. The latter salt modifies in a great measure the colour and intensity of the print produced. From this circumstance, we account for the different tones in different specimens of prepared paper. Some manufacturers use chloride of ammonium, others that of potassium, sodium, or lithium, in the salting of their paper; each print, on this account, will have a different tone when it leaves the printing frame."

Under the title, "Coagulation of Albumen," I find in the leading article of the *British*, for Feb. 16th, some statements of the editor's, which require a passing notice. Alluding to MM. Devanne and Girard, he says:—"They go into another phaso of the question, which has disturbed the equanimity of our antagonist, Mr. George Price—we mean that of the amount of albuminate of silver, in comparison with the chloride, produced upon a piece of positive photographic paper, on being sensitized on the nitrate of silver bath." Now, there is not a single word of truth in any part of this assertion; the whole of it is such pure fiction, as not to have even the shadow of a fact for its foundation. I am no antagonist of Mr. Shadbolt in any way whatever, not having as yet entered into any controversy with him; and moreover, my antagonism is against fallacies, and not against persons. I was the first person who drew attention to the erroneous ideas prevalent respecting the coagulation of dried albumen; and I believe also, that I am the only one who has calculated from an atomic weight, the amount of albuminate of silver on a sheet of albumenized photographic paper; and how my equanimity can possibly have been disturbed by so doing, I am at a loss to imagine, I only know that it has not been so in reality, for nothing I have ever written respecting the impossibility of coagulating dried albumen, has yet been disproved, although I have publicly challenged any one to do so. Mr. Shadbolt takes an exceedingly lofty flight in the realms of fiction, when he states the subject of MM. Davanne and Girard's investigations to be "the amount of albuminate of silver in comparison with the chloride, produced upon a piece of positive albumenized paper on being sensitized on the nitrate of silver bath;" the plain matter of fact being that their paper has no reference whatever to the amount of albuminate of silver in comparison with the chloride; they investigate simply "the action of nitrate of silver upon albumen," without any reference to either the alkaline chloride on the paper before sensitizing, or the chloride of silver produced by its being sensitized; and they state merely that varying strengths of the nitrate of silver solution produces varying degrees of coagulation of the albumen, and therefore varying compounds of albumen and nitrate of silver; a previously well-known fact. Because I calculated according to a particular atomic weight, it is a strange perversion of logic to assume, as Mr. Shadbolt does, when he says that its combination in other proportions is "an idea apparently ignored by Mr. Price." It happens, however, that for more than twenty years I have been well aware of the different character of the precipitates which varying strengths of solutions of metallic salts produce when mixed with albumen.

Mr. Shadbolt also says:—he alludes to the subject "for the purpose of discussing the accuracy or otherwise of certain propositions advocated and maintained by the editor of a contemporary and one of his correspondents, in opposition to certain others held by ourselves and one of our contributors." As what I have written appeared in the NEWS long before the *British* took any notice of the subject, I cannot have stated opinions "in opposition" to certain others held by its editor and one of its contributors; moreover, Mr. Shadbolt is the only person who

has written in the *British* on the subject, and then it was only in reply to a letter of mine, when, amidst much misrepresentation and personal abuse of myself, he denied that this contributor entertained the opinion I had attributed to him in that letter. What I wrote respecting the non-possibility of coagulating dried albumen was corroborated by Mr. Simpson before this; and it must be borne in mind that I commenced writing about albumen two years ago, although it is only lately that I have succeeded in arousing attention.

Mr. Shadbolt also says:—"It has been contended by one or both of our opponents that albumen, in contact with nitrate of silver and some other metallic salts, does not undergo coagulation, but merely combination with the metallic base." I am sorry to say that there is also not a word of truth in this statement; neither Mr. Simpson nor myself have ever said or written anything of the kind; and as Mr. Shadbolt has not ventured to gainsay aught that I have advanced, and has not published his opinions upon the subject of albumen, we cannot be his "opponents." He proceeds to say:—"We, on the contrary, maintained that there was no evidence to show that coagulation did not come about contemporaneously with combination, and cited several authorities in support of this view." This statement of what he himself wrote in his own former leader, is also pure fiction; Mr. Shadbolt maintained nothing whatever of the kind he now says he did, nor did he cite any authorities to the purport he states; in what he did say on the subject he merely attempted to show that coagulation and insolubility were considered as synonymous terms, and to prove it he cited an authority who said nothing upon the subject.

I have reluctantly felt compelled, in justice to myself, to take this notice of Mr. Shadbolt, and much regret to find that such gross misstatements and fictions can emanate from the editor of a scientific journal which claims to hold high rank amongst its contemporaries. With an apology for the extra length of time my addendum has claimed your attention, I now leave the proposed questions in your hands, to discuss in whole or part, or not at all, as you think best.

ON THE ELECTRICAL THEORY OF PHOTOGRAPHY.

BY JOHN JOHNSTONE.*

I STAND before you, this evening, with much diffidence; and, if I should fail in imparting information to recompense you for the time devoted to me, I trust you will vent your disappointment on your fellow-member, my friend Mr. J. E. Mayall; but, should the contrary be the case, he is no less entitled to your vote of thanks for his impertunity in inducing me to appear before you. The subject announced is the electric theory of photography. It might possibly have been better if announced as an electric theory of photography, as several others have been nibbling at the same bait; but, so far as I know, no one has as yet developed a great principle as a foundation upon which to build with certainty. It is my intention this evening, if possible, to lay a firm foundation on which scientific workmen may build a superstructure sound in all its parts. I have had some doubt in my mind as to the best mode in which to introduce the subject, being aware that many of you are well versed in every department of knowledge bearing on photography; yet, from my own experience, in conversing with photographic friends, I have found a great difficulty in making them clearly comprehend the nature of electrical polarisation. If you will bear with me a short time, I will lay before you a few facts in connection with my own impressions as to the nature of heat, electricity, and light.

When a boy at school, it was a habit with some of the more mischievous to cut a metal button from their coat, rub it on the desk, and then apply it to the cheek or back of the hand of their neighbour. This produced a startling effect, often eliciting a retort not very pleasing to the offender. But simple as this experiment may seem, it lies at the basis of electric phenomena. Let us vary the experiment a little by drawing the button rapidly, with a certain amount of pressure, over about eighteen inches of the surface of the facia of a painted architrave of a door. We find that adhesion of the button is the consequence. How is this to be accounted for? In the first instance we have heat generated between a conductor and a partial non-conductor of electricity by friction or abrasion. In the second case we have the same thing, a little modified; in drawing the button along, we generate heat, but the two bodies are not equal con-

* Read at a meeting of the Photographic Society (London), March 2nd, 1863

ductors of electricity; we find that the metallic button has lost a portion of heat in its transit, thereby creating a polarised condition, causing an attraction between the two bodies. Let us now turn to the phenomena exhibited by the electrical machine in its ordinary working, having the silk rubber amalgamated in the usual way, and a metal conductor connected with the glass cylinder, and a similar one connected with the silk rubber. On turning the handle, heat is generated; but, as the glass and silk have unequal attraction for electricity, the heat is split up into a positive and negative condition, accumulating in the two conductors. Let us now attach a wire to each conductor (having the whole machine insulated) bringing the other ends nearly in contact; here the charged conductors have transferred their charge of electricity to the points of the wire, where it is palpable to our senses, as light and heat—this flow of electricity may be made to do duty chemically for any length of time, proving clearly that the earth is not necessary for the continuous supply of either the positive or negative element. After exciting the machine, it will be found that the glass cylinder is quite neutral, the whole of the developed electricity being concentrated near the ends of the wires. If a conductor is charged positively, and any other body (either solid or gaseous) be brought nearly in contact, an induced electrical condition is the result—that is, the part of the body nearest to the conductor will be in a negative condition, and the other extreme in a positive one—leaving the centre of the intermediate space quite neutral.

Now let us turn our attention for a short time to the action of the galvanic battery in the production of electricity. It is well known that if a plate of zinc and of copper are brought in contact for a short time, and then rapidly separated, the zinc plate indicates positive electricity, showing that the copper has parted with a portion of its constituent electricity. Let us now connect these two plates with a wire, immersing them in a solution of salt slightly acidified, or water only with a little acid to increase the conducting power—we now see a continuous flow of electricity resulting in chemical action; on tracing the current we find that the copper has, in the first instance, yielded a portion of positive electricity to the zinc—the zinc being in a state of tension polarises the intervening fluid or electrolyte—hence the negative element of the fluid unites to the positive electricity of the zinc—the positive element uniting with the negative copper thus producing a normal condition between the copper and zinc, so that a continuous supply of electricity is kept up from the copper to the zinc. It is rather difficult to comprehend the state of the polarised fluid; but, as an assistance, let us imagine a tangible image by supposing while the plates are in metallic contact that the fluid between exists in a similar condition to a portion of a vibrating string cut in the centre of the adjoining vibration; having the nodal point in the centre where there is no action. Now, let us separate the connecting wires, when at once we transfer the polarising points to the ends of the wires, leaving the plates and electrolyte quite neutral.

As a further illustration of polarisation from only one polarising point, let us take a long narrow gutta-percha trough, having a copper bottom, to which a small piece of zinc is soldered at one end; on filling up the trough with water, slightly acidulated with sulphuric acid, at once an electric and chemical action is produced, the copper being electrically protected through the polarising of the zinc. Let us vary the experiment by dividing the trough in the centre with a solid diaphragm, filling each cell with acidulated water, in a short time it will be observable, that in the cell farthest from the zinc the copper is corroded by the acid as if no zinc were in contact, but in the other cell perfect protection is given; by substituting a porous diaphragm, complete protection is given to the whole plate, clearly showing that it is the fluid only that is polarised. If the trough is long in proportion to the size of the zinc, protection will not be extended to the extreme end of the copper, because of the induced positive action at that end, through the polarised state of the electrolyte.

We will now draw your attention for a few minutes to the nature of chemical action. Let us take two plates of platinum charging one of them positively; then immerse them face to face in acidulated water. No action will be observable; but bringing the unimmersed ends in contact, immediately chemical action is instituted in the electrolyte. We may vary the experiment by using a test-tube, inverted, having a platinum wire inside, supported by a perforated cork; let the tube be partially immersed in a solution of gold, rendered quite neutral with soda. No action will be observable; but on substituting hydrogen for atmospheric air, chemical action is at once set up, resulting in

a deposition of gold on the immersed end of the wire. It seems quite evident that the platinum wire has been deranged in its electrical quiescence through its polarisation: hence the chemical decomposition of the gold solution. And we may conclude that all chemical action is preceded by electrical derangement; for the disturbed state of the electrical equilibrium involves a disturbed state of the molecules of matter; as one disturbance does not occur without the other. We are, therefore, induced to accept this compound disturbance as chemical action. We may thus conclude that chemical action is the visible exhibition of electrical influences on bodies at insensible distances.

We may now make a few remarks on the nature of light and heat. It is recorded in the first book of the Scriptures that light was a distinct creation, consequently solar light is unique of its kind, all other lights requiring force in some way or other to bring them forth. Experience tells us that light generates heat in our atmosphere, and on the solid surface of our earth, as there is no direct evidence that heat rays emanate from the sun, but rather to the contrary; for, on ascending the highest mountains, we find a continued diminution of solar heat; on descending to the lowest valley, the reverse is the case. No doubt there is a cause for this, and may it not be accounted for by accepting the power of light in eliciting electricity in an allotropic condition in the form of heat? Many facts might be adduced to corroborate this view; but we will only allude to one at present. It is well known that the heat passing from the fire through the boiler plate enters into combination with the water, generating steam, in which it is said to become latent; but by a peculiar modification of the exit of the steam, this latent heat is transformed into positive electricity in enormous quantity.

By applying heat to a glass cup containing sulphur, when sufficiently cold (if separated), the sulphur will be found negatively electrical, and the glass will be positive; by using a metal cup the result will be reversed.

To show how easily the electrical quiescence of some bodies may be disturbed, let us take a mixture of phosphorus and any gum or saccharine matter, with a small portion of nitrate of potash made into a paste, having the temperature raised to what the hand can bear with ease, in the course of an hour or two there will be nothing left but the carbon and potash. Again, if we take a small portion of phosphorus oil and bisulphide of carbon, spread on paper, raising the temperature to about 90° to 95°, flame will instantly ensue.

Light—in passing through our atmosphere—produces a peculiar electrical condition; the oxygen showing itself in a state of electrical activity. If we take two bottles filled with atmospheric air from a dark room, having suspended from the stopper a piece of paper that has been previously moistened with the usual preparation of manganese, or with pyrogallic acid and potash, placing one bottle in the sun, after a time the paper in the sun will show strong indications of electrized oxygen or ozonized air, while the paper in the dark will exhibit little indications of changes. Light has great power in producing various changes in bodies both electrically and chemically; for instance, in upsetting the equilibrium of the two gases, chlorine and hydrogen, forming hydrochloric acid. Light again is found to be a powerful agent in decomposing the oxides of the perfect metals, such as the silver salts. The decomposition of nitric acid has long been known through the action of light being resolved into oxygen and nitrous acid. If we admit that light has power to derange the electrical quiescence of one or more elements in a compound, there can be little difficulty in comprehending that chemical action follows.

Having said all that I think will be requisite to base photographic action upon, I will at once proceed to apply these principles to an explanation of photographic phenomena.

The daguerreotype process being the first in use, and well adapted to simplify the application of the principle, I think it well to explain it first.

To produce a good daguerreotype picture it is requisite to have a plate well cleaned and polished, leaving it free from all impurities, exposing it to the vapour of iodine and bromine in proper proportions, and, after due exposure in the camera and development in the mercury-box, a perfect picture will be the result. Now in this routine all seems simple enough, excepting how the change has been produced from the action of the light in the camera, causing the silver to combine with mercury when the light has acted, and resisting it for a time where it has not done so. Though several surmises have been made from time to time as to the true cause, I believe it has fallen to my own lot to

explain that cause. Experience tells us that the more pure is the silver surface prior to exposure over the iodine and bromine the more perfect will be the finished result (the reason will be given afterwards). When the plate is coated we have a thin film of iodide and bromide of silver easily deranged by the action of light in its electric quiescence, the parts where the light has infringed being left in a positive condition, the other portions remaining perfectly neutral. When this plate is exposed to the action of vapour of mercury the electric tension existing polarises the vapour in contact to a limited distance; thus an attraction is set up, causing a combination of the two metals. As long as the polarising force is kept up the neutral parts of the plate are protected in zones proportional to the polarising force produced through the tension of the plate. When the induced positive parts of the plate are neutralised the protection at once ceases, and the mercury condenses mechanically over the whole surface. Any operator having practised with a small ring-lens on a two and a half inch plate must have seen the practical result of this theory of action. Under the best of circumstances condensation takes place towards the edges almost from the commencement of exposure to the vapour of mercury, thus showing that the small electrified surface in a state of tension in the centre does not yield the conservative power beyond a certain area. In very dull, damp weather, if the plates used are not perfectly pure in themselves, or badly cleaned, a good clear result cannot be obtained; but under such circumstances, after the plate has been cleaned in the ordinary way, then coated with any greasy body (those, of course, being good non-conductors are preferable), perfectly free from water, leaving just so much as will coat the organic and other matters in the pores of the silver surface; then giving the requisite amount of iodine and bromine, but exposing in the camera only for one-fourth to one-third of the time required in ordinary cases. Now, in developing, it will be found that it requires three or four times as long as is required for an ordinary plate to get sufficient mercury deposited to produce a vigorous picture.

Here we have two modes of preparing the plate, resulting in a great disparity of time requisite in the camera; this has generally been attributed to a greater degree of sensitiveness in the one case over the other; but, with all due deference, I beg to suggest a different solution of the matter. In the first case we have a plate often impure in itself with the addition of a portion of the cleaning matters used left in the pores of the plate, so that in the course of developing, local electric action is set up before the whole of the polarising power of the plate has been exhausted, rendering it necessary to check further exposure, else the blacks of the picture would become spotted with mercury. In the second case we have a plate, where all local action is prevented by rendering the whole surface nearly perfect as a non-conductor, permitting the whole tensile force to be exhausted in attracting the mercurial vapour.

As a further evidence of the truth of an electrically disturbed condition of the iodized surface, I may allude to the condition denominated solarisation: every operator knows that an excess of light produces a peculiar action on the prepared plate, causing such parts to unite with a very limited portion of mercury, whence a peculiar blue coloured amalgam is the result. Taking the electric principle as a guide, I believe we shall have little difficulty in solving this phase in daguerreotyping. In a thinly-coated plate the solarising point is soon arrived at: in a deeply-coated one—somewhat longer—so that thickness of the film of iodide of silver has something to do in the matter. Now if we admit that light acting on a prepared surface for a definite time, induces a positive condition to a certain depth—but if prolonged the whole thickness will be in a state of tension—hence the pure silver below becomes a defender of that electrical tension produced by the action of light, consequently on those portions of the plate that are over exposed by losing a great portion of their polarising power a smaller quantity of mercury is attracted.

To show that this is the correct view of the matter, insulate a plate in the camera-slide, charge the back of the plate positively with frictional electricity of a low degree of tension; after exposing a time that would usually solarise the plate, convey the slide to the mercury-box for the usual time, when it will be seen that no blueness exists, but a good solid white will be the result.

I might now go on to apply these principles to the unravelling of every little difficulty arising at times in the manipulatory processes; but as I think it would be superogatory on my part to do so, thinking every intelligent mind will be able to apply the principle himself.

In point of time the talbotype process comes next; but as the same leading principles are common to the albumen-waxed-paper and collodion processes, I need say little about the paper varieties, leaving the full examination for the collodion processes.

In the calotype processes we have an iodide of silver formed in the paper, serving the same purpose as that on the daguerreotype plate, namely, a negative quiescent surface easily deranged by the action of light from a negative to a positive condition, polarising the developing fluid while in a state of decomposition, thereby determining a deposition on the light-affected portions of the sheet.

The long-keeping qualities of sensitized waxed-paper proceeds from the pores of the paper being filled with pure wax (an excellent conductor), enveloping each fibre, thus doing away with the local action incurred where simple paper is used. Some paper sized with heterogeneous materials cannot be preserved for any time, nor can the developing be protracted sufficiently to make a clear strong picture.

Pyroxyline, whether prepared from cotton or flax fibre, when kept for a time, exhibits symptoms of decomposition by giving off the elements of nitric acid. When dissolved in ether, it seems to remain in a comparatively stable state; but when any of the alkaline iodides are added, chemical affinity is soon brought into play in proportion according to the alkali used, the metallic iodides having little attraction for the nitric element of the pyroxyline; but little decomposition ensues for a considerable time.

The ordinary routine of iodizing the collodion, spreading on the glass, sensitizing in the bath, exposing, developing, and fixing, I need not describe; but at once enter into the causes of the various changes produced in the film, tending to a perfect result. When a plate is coated and immersed for a time in the silver bath, the iodide of silver precipitated in the collodion film is in a very favourable condition to be excited by the electrical action of the light in the camera. On application of the developing fluid an electrolytic action is set up in the fluid, similar to the induced action previously explained in the mercurial development of the daguerreotype. The various changes produced in the development of a picture have generally been explained on chemical principles. But as I conceive the great principle desired is that upon which depends the production of all chemical action; for it seems to me that all chemical action is the result of a previous disturbed electrical equilibrium as shown previously.

Let us now take a more minute survey of a collodion picture. In the first place we have a sheet of glass, a neutral non-conductor, on which is spread a film of collodion (properly iodized); this collodion is likewise a non-conductor, the iodide and bromide of silver also having the same properties in a high degree. Here we have everything negatively quiescent, but on partial exposure and on flooding with a developer (such as gallic acid, pyrogallic acid, or sulphate of iron) at once a controlling action is set up by the electrified portions of the plate, determining a deposition of deoxidized silver on the light-affected parts; but, without an acid in the developer, it is scarcely possible to carry on the development without a fogged state intervening. The use of acid, I think, has not been clearly understood hitherto. It seems to me to be useful simply as a conductor of electricity; for, if we use any of the salts undecomposable by the developing agents being slightly on the acid side, perfect development will be the result.

It is well known that an old decomposed collodion tends to give brilliant, clean, hard pictures. Now, assuming that my idea as to the use of acid is correct, there will be little difficulty in comprehending the reason of this property of old collodion, or collodion holding a portion of iodine or bromine in a free state; for when the coated plate is immersed in the silver bath, iodide of silver and nitrate of potash (or other base) is formed in their definite proportions. The free iodine in the film will unite with its constituent portion of silver, leaving an equivalent of nitric acid free in the film just where it is wanted, for on pouring on the developer its conducting power is at once continued through the body of the film, checking any tendency to local action on the lower side of the film. That all the stains and dirtiness are upon the glass surface is easily provable; for by transferring a dirty picture to leather or prepared card, letting dry, then rubbing with cotton-wool, all the useless deposition will be cleared away, leaving a perfect and clean picture. Having said enough as to the practicability and utility of these views, I will conclude for the present, trusting you will pursue a course in accordance with them, and thereby develop the photographic art into a fixed science.

Proceedings of Societies.

SOUTH LONDON PHOTOGRAPHIC SOCIETY.

THE usual monthly meeting of this Society was held on the evening of Thursday, the 12th inst., in the City of London College. F. F. STATHAM, Esq., M.A., F.G.S., in the chair.

The minutes of a previous meeting having been read and confirmed,

Mr. G. WHARTON SIMPSON called attention to a couple of large photographs by M. Jeanrenaud, one of the ablest landscape photographers in France. They were worthy of examination, he remarked, for their excellence, but the especial object for which they had been forwarded by that artist was to illustrate the very great amount of angle he had been able to include with satisfactory definition by using Dallmeyer's No. 4 triple lens. M. Jeanrenaud had marked on the picture the amount of subject included by one of the best French landscape lenses of similar focus, which was about one-third of the picture less than was given with the triple. There was, moreover, considerable depth of definition. The photographs, which were from dry plates, by M. Puech's dry collodion, were very fine. Mr. Simpson also announced that the prints by Mr. A. Burns were now ready for distribution. He had written, asking Mr. Burns for a few particulars of his method of working in producing such views, in the form of a short paper for the Society. He would read the part of his letter referring to the subject, which was as follows;—

"With regard to a paper for the Society on obtaining cloud negatives and printing in skies, I fear I cannot do anything in that way. What little I do know on the subject is just what has appeared in the News and other journals, and a mere compilation by such an indifferent hand would not profitably occupy the time of the South London Photographic Society.

"The card picture is printed from a stereo negative obtained by the ordinary Fothergill process, very early (about 5 a.m.) one morning in June last, the exposure with a pair of Horne and Thornthwaite's small new lenses and smalls top, from beginning to end occupied 60 seconds, but the whole plate did not receive so much time, the lens being opened and closed *very slowly* by a shutter inside the camera, so that the immediate foreground would receive at least double the exposure of the distant castle &c. In this way I sometimes manage so as to obtain natural skies, and in the negative referred to, all the clouds present at the time may be seen in the negative, but too dense to print with the rest of the picture."

Mr. G. PRICE then read a paper on "The Theory of Positive Printing.—Albumenized Paper, and the Action of the Sensitizing Bath" (see p. 126 and p. 137). After which the Chairman, in moving a vote of thanks to Mr. Price for his very able paper on a subject of great interest and importance.

If the question were thoroughly examined, it opened a very considerable scope for inquiry. It was perhaps a matter for a little regret that any subject of personal antagonism had been introduced into the paper, and he would suggest that this part of the paper was scarcely suitable for discussion in a society's meeting. The subject presented ample field for discussion, however, and had been most comprehensively treated. There was first the general question, and then the distinctive propositions with which Mr. Price concluded his paper, which he (the Chairman) again read to bring them under the immediate attention of the meeting.

Mr. PRICE explained that the observations in his addendum were not intended for discussion. There was, however, neither personality nor antagonism intended. He had felt it important to clear the subject of certain mis-statements, and he had taken the advice of several unprejudiced persons and some friends of the *British Journal*, who all had concurred in the recommendation that they should be rebutted in this way. He had felt no antagonism, intended no personality, and only wished an important subject to be cleared from misleading statements, that the truth might be established.

Mr. SEBASTIAN DAVIS asked Mr. Price whether he had formed any opinion as to the constitution of the salts formed by weak solutions of nitrate of silver and albumen as compared with those formed by strong solutions. Did he regard them as differing in chemical character?

Mr. PRICE had, in his paper, simply referred to Messrs. Davanne and Girard's statements on the subject, in which they repeated a fact well known before.

Mr. DAVIS was not aware that it was known that a precipitate of different character was formed.

Mr. PRICE said they did not say that, neither did he; but, nevertheless, there must be a difference in the chemical constitution, or there could be no difference in the character of the precipitate.

Mr. DAVIS said the subject was a difficult and complex one, and considerable doubt existed as to the calculation of the equivalent of albumen, as it was necessary to multiply the different elements in order to state the proportion of sulphur and phosphorus.

Mr. MARTIN said that from analogical cases he would lead to the conviction that a definite chemical compound would be formed, whatever the strength of the solution—the difference in physical appearance, described by MM. Davanne and Girard, arising in his (Mr. Martin's) opinion solely from the variable state of agglomeration of the particles; that, in short, a definite compound of albumen and nitrate of silver was formed in each case, just as gelatinous alumina and pulverulent alumina—the one obtained from a cold solution and the other from a hot solution—were nevertheless both alumina.

Mr. PRICE held that all combinations below that which produced complete saturation were imperfect albuminates.

Mr. DAVIS asked what Mr. Price understood by imperfect albuminates.

Mr. PRICE said that by the term albuminate or perfect albuminate of silver he meant the highest or most complete combination, which produced what was termed complete coagulation. Combinations below that he would call imperfect albuminates.

After some further conversation on the subject,

Mr. HART thought that precipitates produced by weak or strong solutions were identical in constitution, albumen being a highly colloid substance, the more dense the solution the more firmly it held any salts of silver, so that a higher amount of silver was found in the dense precipitates than in the light precipitates.

Mr. PRICE asked Mr. Davis if he considered the albuminate of silver a combination of albumen with nitrate of silver, as a whole, or as a phosphate, carbonate, &c.

Mr. DAVIS was uncertain, but should say it combined as a whole.

Mr. HART had analysed the ashes of some albumenized papers after burning and found them to contain sulphide of silver.

Mr. DAVIS expressed surprise that Mr. Price should imagine that it was not generally known that the base of the chloride used, and the nature of the nitrates formed affected the tone of the print. The idea that they did affect the print had been held for years. He remembered that some years ago Mr. Heath brought the subject under the attention of the parent society.

Mr. PRICE said that so far as he had been able to ascertain the notion had not been commonly held. An article which appeared in the journal of the Photographic Society referred to that idea as having *recently* gained some attention. He knew that it had been held by some that barium affected the colour of the print, because of a combination between the albumen and the barium; but he had tried everywhere almost in London without being able to meet with albumenized paper salted with barium.

A conversational discussion arose on the question whether the action of the nitrates had been recognized, and upon the use of barium paper and the difficulty of obtaining it.

Mr. HARMAN thought chloride of ammonium was the best salting chloride; and the reason was, that the prints were always red in the pressure-frame, so that there was more control and certainty in toning them.

Mr. HOWARD thought that one of the advantages of ammonium arose from the fact that it was a ready solvent of salts of silver, and thus aided in producing even homogeneous film of silver on the albumenized paper, by the more ready assimilation as it were.

Mr. PRICE asked Mr. Harman if the redness in the pressure-frame was not rather due to the proportion of albuminate of silver than to the base of the chloride.

Mr. HARMAN said that some samples of albumenized paper would print black, no matter how much albumen there might be.

Mr. PRICE said that was a question of the proportion between the two; if the chloride were in greater proportion it would print dark.

A conversational discussion on this subject followed in which Mr. BLANCHARD mentioned the curious circumstance that a certain pair of negatives, printed on the same paper at the same time, in the same light, and with the same exposure, one gave a red print and the other a purple tint, the result always being the same.

Mr. HART had noticed that on mixing chloride of ammonium with albumen a decomposition took place, in which ammoniacal gas was given off. The chlorine either combined with some base in the albumen or with the albumen itself. The prints on such paper were probably redder because there was a less amount of base. He had printed two pictures which he would then show—one on normal albumen, the other on albumen with chloride of ammonium. When the ammonium paper was fully printed the albumen paper only showed signs of appearing; in fact, it took three times as long as the other to print. In toning the ammonium print occupied twelve minutes and the albumen sixteen minutes. The albumen alone never got deeper in the pressure frame than a salmon colour. Regarding coagulation, he had some experiments in progress which would he hoped throw light upon it. If the albumen combined with the silver, what became of the nitric acid liberated? That would act very specifically on the albumen, for it was well known that nitric acid was the most powerful test for albumen, a five thousandth part being sufficient to produce insolubility.

Mr. WHARTON SIMPSON said that one important element in giving this specific colour to the print in the pressure frame had not been noticed. He referred to the kind of light in which they were exposed. Most photographers would have observed, that paper which, exposed to soft diffused light, printed with a blue or purple tint, when exposed to sunlight assumed a red tint. He had recently carried the matter further, and but for the pressure of more immediate duties, he would have completed experiments to the present meeting. He found, when submitting a piece of sensitive paper to the concentrated light of a lens, that a still different tint was produced, so that three distinct tones were produced on one piece of paper, the difference caused by light alone. At one end of a piece of paper, placed at the focus of a lens in sunlight, the tint produced very rapidly was of an orange tint, and that produced, it was very slow to go beyond it; direct sunlight gave a reddish brown, and diffused light a purple. These distinctive differences were less marked after toning and fixing, but they still remained the same in character.

Mr. HARMAN and Mr. HART confirmed the view that the character of the light largely influenced the colour.

Mr. HOWARD suggested that heat might have something to do with the colour.

After some further conversation, Mr. HARMAN, referring to Mr. PRICE's summary of questions said, that he found vigour to depend largely on the use of a strong solution and short floating, the prints were produced by shorter exposures, and were more brilliant.

Mr. PRICE asked if in such case he found it necessary to print deeper, or if the prints lost more in toning and fixing than with a weaker bath.

Mr. HARMAN did not find any deeper printing necessary.

This view was confirmed by Mr. DAVIS and Mr. LEAKE.

Mr. T. R. WILLIAMS quite agreed with the remarks of Mr. Harman, especially as to the advantage of prints appearing red in the pressure frame. A great advantage was the possibility then of seeing exactly the amount of toning effected, which was very difficult where the print was blue to begin with. Regarding the use of barium, he felt assured of its advantage, and had used five grains of barium and five grains of ammonium for many years. There appeared to him considerable misapprehension to exist regarding the necessity, under all circumstances, for over-printing. In his establishment they scarcely printed any deeper than was required in the finished print. This, through the experiments of Mr. Cooper, they had discovered to depend upon the use of distilled or rain water for washing before toning, as, when common water was used, deeper printing was necessary.

Mr. LEAKE referred to a recent trial he had made of some paper which was albumenized without any chloride. It gave flat, poor, meagre prints. He had recommended the maker to use 10 grains of chloride of ammonium, which was attended with a great improvement in the prints. He thought it a pity that manufacturers of albumenized paper would not state the proportion and nature of the salt used in salting the paper, as at present they were obliged to proceed very much on the

principle of putting a lump into a tolerable sized jug. The system of printing was exceedingly empirical. All papers were treated alike both as to silver bath and toning, and no distinction was made as a rule between the requirements of feeble or vigorous negatives.

Mr. SIMPSON said, Mr. Leake's experience with paper simply albumenized was somewhat at variance with general experience, as excess of vigour and lack of half-tone, was the general result of such paper, as indeed the examples exhibited by Mr. Hart illustrated.

Mr. HART said, in his experience it was almost impossible to get anything but black and white, without half-tone with such paper.

Mr. HARMAN had always found the smaller the proportion of chloride, the slower the printing, and the more brilliant the print.

Mr. DAVIS remarked, in reference to the loss in toning and fixing, when common water was used for washing, that he had prepared a piece of plain paper by floating on nitrate of silver; and obtaining a blue print in the pressure-frame had immersed in chloride of sodium previous to toning, which caused it to assume a bright red colour, showing the reaction of nitrate of silver and chloride of sodium in the print.

Mr. HART had directed attention to the advantages derivable from the use of soft water in a letter to the PHOTOGRAPHIC NEWS three years ago. He had been in the midst of some serious toning troubles, which the use of a softer water for washing at once relieved him from.

After some further conversation,

Mr. SIMPSON moved the adjournment of the discussion, as it was now late, and the subject was not exhausted. This was agreed to, and it was announced that Mr. Harmer would also read a paper "On Mask Printing," and Mr. Cooper a brief communication "On Substitutes for Albumen." After a vote of thanks to the Chairman, the meeting was then adjourned.

Photographic Notes and Queries.

WORKING HOURS OF PHOTOGRAPHERS.

MY DEAR SIR,—In your last Number I saw, in the "Answers to Correspondents," an allusion to some complaints emanating from the employés of a photographic establishment at Notting Hill.

As I know of no other business of that kind in the neighbourhood than my own, I, in justice to myself, beg to offer you the other side of the question. In the first place, no one in my employ has worked more than seven hours and a half this winter and during short days and foggy weather. I will leave you to judge how much of that time could be profitably employed.

As the longer days are now coming in I desired the men to work nine hours per day and the boys nine hours and a half. All time beyond that I have always paid for, both to men and boys.

A notion seems to have entered their heads that they should work the same hours only as operators employed in the close confinement of the dark room, and at that requiring infinitely more head work than printing, divided, as it is, into different branches, each one to his own department.

Several of my hands I could have well dispensed with, but having had their services through the summer, I have kept them through the winter, and at full wages too.

During this winter I have paid a lad to be here two hours before the others to get the workshops dry and warm, ready for the day's operations.

I now, sir, leave you to judge how tyrannical has been my conduct.

Apologising for thus troubling you, I remain, dear sir, yours obediently,

W. ENGLAND.

P.S.—Since writing the above I have discovered the chief mover in the affair to be an apprentice in the house, of whose character the best I can say (after an experience of five years) is that it is very difficult to get him out of bed before 9 o'clock in the morning.

Photographs Registered during the Past Week.

MR. R. L. ALLAN, 13, Murray Street, Camden Square, N.W.,

Portrait of Rev. George Hogben.

MR. H. C. BOOTH, Harrogate,

Two Photographs of Rev. Arthur Connel.

MESSRS. BECKITT AND WILLIS, 29, Newboro' Street, Scarborough,

Portrait of the late Mr. Harry Beverley, of Scarborough Theatre.

MR. WM. HARDING WARNER, Ross, Herefordshire,

Portrait of Rev. Alexander Crigan, D.D.

MR. E. H. RHODES, High Street, Nantwich,

Three Photographs of Wyburnbury Church and Vicarage, Cheshire.

Talk in the Studio.

MR. MEAGHER'S CAMERA.—The handsome large trunk camera sent by Mr. Meagher to the exhibition of the Photographic Society to be sold on behalf of the Lancashire Fund not having there met with a purchaser, it is now proposed to dispose of it by subscription sale. One hundred shares at five shillings each make the price of the camera; each subscription of that amount entitling the subscriber to one chance in the drawing. Applications for shares should be made to Dr. Diamond, Secretary to the Photographic Society, Twickenham House, Twickenham. The camera is a very perfect one, and well worth the money for a chance.

THE BEST SIDE OF THE FACE FOR PORTRAITURE.—A Correspondent says: There is a point in portraiture that I have never seen hinted at in any photographic publication: it is, that everybody has *two sides* to his face. I might state it less equivocally, however, by saying that the sides of the face are not symmetrical, and you may notice that almost everyone has a better look on one side than on the other. This difference between the sides of the face is much more remarkable in some persons than in others, but in all it may be seen in a certain degree. The nose is always more or less turned to either side, commonly the left, and will consequently alter the expression by rendering one side of the face wider than the other. This point is of considerable importance to portraitists, as they should always take the *best side* of their sitters.

To Correspondents.

COLOURED GLASS.—"A. E. II" sends a sample of glass, which is perfectly satisfactory and non-actinic. The samples sent by "A Man in the Country" are rather of a light brown tint than orange, and are quite unsuited for the dark-room.

A.—Streaks on the plate in the direction of the dip will arise from several causes; but those to which you refer, as appearing generally when fresh silver solution has been added to fill up the bath, probably arise from some floating matter at the surface of the solution, which has accumulated from the sides of the bath; in such case cleaning the surface will frequently remove the streaks. Giving the plate a lateral motion in the bath will often prevent the formation of streaks. The addition of a little nitric acid is often a remedy. Sometimes after taking a few plates it will disappear without further steps.

DR. LANGUE.—We do not know whether any one in this country is agent for M. Berth's camera. 2. From the results we have seen produced it appears good, but we do not know anything of it beyond this.

W. B.—We have no means of accounting certainly for the stain on your print; it appears to have resulted from the action of an acid. 2. It is well to wash thoroughly before toning; two changes of distilled water, if properly manipulated, might be made to remove the greater part of the free nitrate.

D. FERGUSON.—The process referred to is worked by the American Photo-type Company, and, we presume, they are the patentees of the process.

AMARANTH.—The intrinsic value of a 12 by 10 photograph, apart from its value as a picture, may easily be estimated by ascertaining the trade price for printing such photographs, which is about 18s. per dozen. 2. The selling price of photographs of that size varies from 5s. to 10s. and upwards, according to the excellence of the picture and the interest or rarity of the subject. 3. We cannot recommend you a publisher. 4. If you merely wish to make photography pay its own expenses, and have some good negatives, the Amateur Photographic Association will afford you the best facilities for disposing of prints. 5. Reproductions are rarely so valuable as photographs from nature, unless the originals are rare and valuable. 6. There is no reason why a good negative should not be taken on flatted crown. For large plates it is apt to break, and its surface is not quite so good as patent plate. 7. Flatted crown is generally slightly curved, and is not polished like patent plate. The latter is by no means always of one uniform thickness, nor is it always quite free from blemishes; but if of good quality it is tolerably free. The price depends upon the size of the plates; 12 by 10 plates are about 2s. a foot; 8½ by 6½ plates are about 7s. a dozen; but prices vary.

AMATEUR IN ST. THOMAS, W. J.—An ordinary copying camera and suitable lens, say the triple, will answer every purpose for copying oil paintings. We are not aware that any camera has been made for that work only. 2. Unless instructions to the contrary are given we apprehend that the rose tinted albumenized paper should be treated in all respects as that without a tint. See first article in the present number. We are obliged by your kind offer of services in the West Indies.

F. G.—Various substitutes for yellow glass have been tried with more or less of efficiency. Your proposition to use coloured gelatine may probably answer. It is easy to colour it, but it is doubtful whether the colour will be quite non-actinic or permanent. A solution of annatto or saffron will give you a good deep yellow; but these will be apt to fade in sunlight. The addition of a grain of nitrate of silver to each ounce of gelatine solution will, when exposed to light, probably give you a permanent non-actinic colour. Judson's orange dye will probably answer. Coating the plate with plain gelatine, and when nearly dry immersing it in a solution of the colouring matter will probably be a good mode of applying it.

Tnos.—The camera to which you refer being a modern invention is less likely to be obtained second hand than one of older form. We are not very familiar, however, with the class of photographic materials to be obtained second hand; but there are, no doubt, sometimes bargains to be had. The price you quote for the camera referred to is, if we remember

rightly, for a complete equipment of double hacks, leather case, tripod, &c. If you require the camera alone the price would probably be less.

PHOTOGRAPHIC ENTHUSIAST.—A Stanhope lens is a cylindrical piece of glass with both ends convex, of such curves as will make the foci of parallel rays refracted at one surface coincide with the other, so that objects placed in contact with one surface are seen greatly magnified on looking through the other. 2. The Coddington lens is a small spherical lens, with the equatorial portions ground away so as to correct spherical aberrations. Neither of these are suitable for photographic purposes. 3. A movable partition in a belows stereoscopic camera need only come in contact with the edges of the folds, it is not necessary to fit into the gussets. It may be of any convenient material. 4. Some operators use a leather for polishing glasses, just in the condition it is sold; but it is safer to wash it thoroughly in spirits of wine and water. 5. A bromo-iodized collodion will bear a stronger iron developer than a simply iodized sample. 6. In the panoramic pictures exhibited at the London Society, the lens had no part in producing the panoramic results. It was simply a common achromatic stereoscopic lens, and the picture might have been better had the lens defined better. The panoramic result was due to a mechanical contrivance for moving plate and camera in proper ratio during exposure. The specification will be shortly published. 7. It is probable that it would cost you more to make a bad lens than to purchase a good one; even with the best written instructions to guide you. Purchase a good lens if you can; but, at the same time, do not be discouraged if you can only afford a cheap one. By great care and skill good results have been produced by a common single lens.

M. B. L.—By mixing a portion of a toning bath with your silver bath you have simply precipitated a portion of the silver as a chloride, carbonate, acetate, &c., the exact character of the precipitate depending on the constitution of the toning bath. All you can do is to remove the precipitate and recover the silver by reducing it. Then test the clear solution, and ascertain to what extent it is weakened; sufficient nitrate of silver should then be added to make up the proper strength again. 2. A bath which has been used for exciting collodion plates does not give brilliant results when used for paper. In any case you should get rid of as much of the iodide as possible by precipitation, as recommended by Mr. Hardwich; that is, adding a few drops of a solution of citric acid, which, forming a precipitate of citrate of silver, will carry down some of the iodide of silver.

A. R.—A mixture of bichromate of potash and gelatine, when exposed under a transparent positive, and then soaked in water, will give an image in relief; from a gutta-percha mould of which an electrolyte taken would present a block, the raised parts of which would print the blacks of the picture. The property possessed by gelatine, or similar substances, in combination with bichromates, of being rendered insoluble by light, is the germ of the greater part of the heliographic processes. In the process referred to, the parts acted upon by light are insoluble, and are not, therefore, affected by water; whilst the parts not affected by light retain the ordinary property of gelatine when soaked in water, which is, of course, to swell up.

D. W.—The formula and manipulations referred to are, as stated, those of Mr. England. When he states that development is to be effected with "the usual three-grain pyrogallic acid solution," we presume him to mean three grains of pyrogallic acid to an ounce of water, with the usual amount of acetic acid, or citric acid, and a few drops of silver solution.

BRADFORD.—Dr. Hill Norris's plates are generally developed with pyrogallic acid; but if, as you state, you exposed one under a negative for a minute without obtaining a trace of an image on development with iron, it is probable you omitted to add any silver solution to the iron, in which case you would not, of course, obtain an image. An exposure of a minute to daylight should be much too long. As you describe your operations, they are correct; but we presume you neglected to add silver to your developer—an omission which persons unaccustomed to dry plates not unfrequently make. You will find many articles on producing transparencies in our back volumes; we may especially mention one on page 410 of the 6th volume.

A LONDON AMATEUR.—Our opinion coincides with your own as to B. 2. We should recommend B 1, as satisfactorily combining both the capabilities you require. 3. With A 3 you must have stereoscopic lenses as well. 4. So far as our experience goes, the B are in all respects at least quite equal to A.

THOMAS JONES.—Messrs. Marion and Co., of Soho Square, publish original portraits of the Prince and Princess of Wales and of some other members of the Royal Family.

GOOD NIGHT.—We are very highly gratified with your specimens as illustrations of the value of the information referred to. Some of them are very perfect indeed, and equal to those produced by professional photographers of high standing, and all exhibit very careful and intelligent manipulation, and much good taste. We have little to criticise in them or suggest for their improvement. Your lens is, as you doubtless are aware, not quite equal to producing male standing figures. Take care to keep your accessories quiet and subdued, and the same with pictorial backgrounds, suggestion rather than definite making out, is all that is required in each. Many of your pictures are very good in this respect, but some are scarcely so quiet as might be desirable. If you continue to progress in the direction you have done, your work will be inferior to none; it is now superior to much with more pretension. Regarding the rapidity of lenses, the rule is, other things being equal, that the larger the aperture in relation to focal length, the quicker the action, therefore the latter of the two to which you refer would be quickest, and give the best results. Both by the maker you name, are, however, good. If you have length of room, and can afford it, we should recommend the larger one. The salaries of operators in London vary very much. We should say they range from two guineas to five guineas a week, depending on the ability of the operator and the character of the establishment. We shall be glad to hear further from you.

YOUNG PHOTO.—Your specimens arrived so much broken that we could make very little of them. So far as we can judge the fault is simply under exposure. No. 1. appears to be a fogged plate from using a bath in bad condition. Possibly a little nitric acid would remedy that. If not, add carbonate of soda and sun the bath. The other two plates appeared both to be very much under-exposed. It is difficult to say how late in the day you may produce pictures; generally, any time up to sun set, but requiring very long exposures, as the sun is declining. A few lessons from any capable professional photographer would help you very much, but we cannot recommend any one in these columns. A low temperature in the operating room generally makes operating altogether slower.

Several correspondents in our next.

THE PHOTOGRAPHIC NEWS.

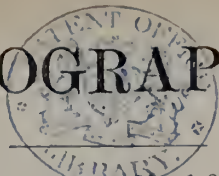

Vol. VII. No. 238. — March 27, 1863.

CONTENTS.

	PAGE		PAGE
M. Meynier's New Fixing Salt	143	The Nitrate of Silver Bath	150
Secret Formule. By Coleman Sellers	146	Photographs in Printing Ink	152
On the Influence of Iodides and Bromides in Collodion, and on the Influence of Developing Agents upon Short or Long Ex- posure. By M. Ommeganck	146	Proceedings of Societies	152
A Short Lesson in Photography.—No. 10	147	Correspondence	154
Preparation of Gutta-Percha Paper. By Alexander Arnstein	143	Photographic Notes and Queries	155
The Stereograph and the Stereoscope	149	Photographs Registered during the past Week	155
		Talk in the Studio	156
		To Correspondents.....	156

M. MEYNIER'S NEW FIXING SALT.

THE application to photography of a salt which might replace hyposulphite of soda and cyanide of potassium, for fixing either negatives or positives, without presenting the inconveniences peculiar to these two substances, was an event too important to the photographic art, and for the permanency of pictures obtained by the aid of salts of silver, not to strongly excite the attention of all who are interested in the progress of science and who regret seeing so many excellent proofs rapidly fade.

The Marseilles Photographic Society, of which M. Meynier is an active member have submitted the new fixing agent to the necessary tests in order to prove its superiority over hyposulphite of soda, and M. Teisseire has made a report upon it, of which we give the substance as recorded in the *Moniteur de la Photographie*. The results are less satisfactory than could have been desired. We hope shortly to record the results of our own experiments in the matter.

The salt proposed by M. Meynier is the sulpho-cyanhydrate of ammonium, which he obtains by mixing the compound of sulphide of ammonium dissolved in water in presence of a porous body, such as sawdust.

Chemistry offers several other methods of preparing this salt. Its elements are, as its name indicates, sulphur, hydrocyanic acid and ammonium. It presents, therefore, some analogy, by its elements, with the three fixing agents hitherto employed in photography—hyposulphite of soda, cyanide of potassium, and ammonia.

Like them, it possesses the property of completely dissolving the chloride, iodide, and bromide of silver, and all identical compounds, and particularly, according to M. Meynier, the sulpho-cyanide of silver which may be formed during the fixing of proofs. M. Meynier states that the new salt is not poisonous like the cyanide of potassium. These properties induced him to employ it for fixing negatives and positives.

The sulpho-cyanhydrate of ammonium dissolves the argentine compounds employed in photography very readily, and its most remarkable property with respect to the permanency of the pictures is, that notwithstanding the presence of sulphur among its elements, it does not precipitate that element under the action of acids, which is the primary cause of the fading of proofs fixed with hyposulphite of soda.

To verify this property a saturated solution of hyposulphite of soda was placed in one test glass, and a saturated solution of sulpho-cyanhydrate of ammonium in another. A drop of acid added to the solution of hyposulphite of soda caused an abundant white precipitate of sulphur. The solution of sulpho-cyanhydrate of ammonium similarly treated, on the contrary, remained limpid. This limpidity was not changed under the action of a very strong proportion of acid. The liquid only became feebly coloured yellow red. From these facts it evidently results that the sulpho-cyanhydrate of ammonium does not precipitate sulphur under the influence of acids, and admitting that some sulphur

must be liberated, soluble compounds only are formed, which will be removed by washing, and leave no sulphur in the substance of the paper.

The next experiment was to ascertain whether the new fixing salt could be applied indifferently to albumenized, and to simply salted paper; the results were stated as follows:—

1st. *Salted paper*.—We believe the new salt to be perfectly applicable to proofs on salted paper, sensitized either in the bath of 15 per cent. of nitrate, or of 5 per cent. of ammoniacal nitrate. The faces come well out without losing much vigour in the fixing. The proof remains perfectly pure in the whites, without taking a yellow tint. (N.B. During the fixing, the following phenomenon takes place: after a few minutes' immersion in the sulpho-cyanhydrate of ammonium bath, the proof becomes covered with a white veil, which is formed by sulpho-cyanide of silver. This veil ultimately disappears, especially if the proof is passed to another new bath, when the picture soon resumes all its vigour).

2nd. *Albumenized paper sensitized in an ammoniacal nitrate bath*.—We have not obtained good results by fixing proofs upon ammoniacal paper, by means of sulpho-cyanhydrate of ammonium. The ammoniacal nitrate solution itself removes some albumen from the paper, and consequently its gloss; the sulpho-cyanhydrate finishes the work, and but very little albumen remains on the proof. The colour given by the toning disappears, and the picture assumes a tint resembling that of proofs fixed in hyposulphite of soda and not toned. The albumen having for the most part disappeared, the pictures have very disagreeable dull tones, with no depth, and the whites become very yellow.

3rd. *Albumenized paper sensitized on an ordinary nitrate bath of 15 to 20 per cent.*—The sulpho-cyanhydrate might be employed to fix proofs on paper with 15 to 20 per cent. of nitrate, if we could prevent the paper turning yellow under its influence. The albumen remains intact. The tones given by the toning bath are well preserved if we take care to force them a little. The picture appears perfectly clear when viewed by transmitted light, but notwithstanding the most careful washing, it becomes yellow when dry. The question arises, Is this effect caused by the presence of sulphur in the elements of the new fixing salt, or by the albumen itself? But the fact is undoubted. We have, in presence of M. Meynier, made comparative experiments with hyposulphite of soda, and the new salt. Some stereoscopic pictures were cut in two, and one half fixed in hyposulphite of soda, and the other half in sulpho-cyanhydrate of ammonium; in the first, the whites remained pure, in the second, they yellowed considerably. Experiments made upon various qualities of paper, gave similar results.

With respect to the permanency of the proofs obtained by this process, time alone can show, if they be more durable than those fixed by hyposulphite of soda.

In conclusion, we think that the sulpho-cyanhydrate of ammonium may be employed in photography for fixing collodion negatives and positives upon salted paper, but that it

cannot be advantageously substituted for hyposulphite of soda, for fixing proofs upon albumenized paper, until we find means of avoiding the yellow hue it communicates to these papers.

We have not examined whether the new salt be poisonous or not. M. Meynier affirms that it is not.

SECRET FORMULÆ.

BY COLEMAN SELLERS.*

MR. PRESIDENT, I beg your attention for a few minutes this evening in reference to a matter which may serve as an illustration of one of the uses of photographic societies in general, and at the same time prevent some of those now present spending money needlessly.

There have always been persons who make a business of selling wonderful formulæ; in many cases they charge pretty well for their information, and in my own experience the ones thus trading are not always the originators of the processes vended. But to the point. I have in my possession a circular issued by a respectable house in New York, calling attention to a pamphlet which they offer for sale for the moderate sum of three dollars, and which is said to describe "a new process of photographic printing by which from 25 to 30 grains of silver will produce better results than were obtained by using 80 to 120 grains to the ounce of solution," and detailing many advantages as to keeping qualities, &c. Now this pamphlet, when received, is found to describe what (to use their own words) "may be called the fuming process, and consists in part in applying the fumes of ammonia to the paper after it is silvered, instead of using ammonia in solution with the silver, thereby increasing the sensibility of the paper without injuring the albumen surface." It then gives the proportion of silver solution thus:—

Water	1 ounce
Nitrate of silver	25 to 30 grains	
Nitrate of ammonia	3 grains.	

"Float the paper on this solution from three to five minutes, then hang up to dry by one corner. When it is dry it assumes a cone-like shape, and will keep in a dark room several days. When wanted to use place it in a box described in the drawing. Close the door and remove the stopple from the ammonia bottle, and allow the fumes to pass to the paper for five minutes. Then put in the stopple, and open the large door which will allow the fumes to pass off. The paper may be removed as wanted for use."

Now all this is very well. It is without exception one of the very best means of sensitizing albumen paper; and doubtless it is cheap at three dollars. But if it had been published in any of the public journals which we were in the habit of reading, and we had thus become possessed of the information in advance, we would all object to paying the three dollars. And, what is more, we would question the right of any party to make capital out of this public property.

In the last volume of *The American Journal of Photography*, Mr. Seely described the fuming process, and his article was copied abroad, even translated into French, and yet it did not attract one half the attention its importance demanded; as far as I can learn few persons availing themselves of it, and that mainly because its importance was not dwelt upon by the writer. The firm of E. and H. T. Anthony had been practising the method for several years, and Mr. Henry T. Anthony claims to have been the originator of it, as applied to albumen paper. While a Mr. Campbell four years ago published the process for plain paper in Vol. I., *American Journal*.

Now regarding the twenty-five to thirty grains bath. At the meeting of the Photographic Society of Marseilles, France, held on the 28th of February, 1862, "M. Terris described to the society a sensitizing bath which he used for albumen paper. To a bath of nitrate of silver of twenty-five grains to the ounce he added a certain quantity of nitrate of ammonia, which he alleged to preserve the albumen on the surface of the paper, and asserted that his toning was good even with so weak a bath as indicated, in proof of which he exhibited a set of beautiful cartes de visite." This was published in the English journals, and could have been seen by any one who was in the habit of reading the papers. It attracted my attention from

having, previously to the receipt of it, written on the ammonia-nitrate of silver for albumen paper, and stated that it was more properly a solution of oxide of silver in nitrate of ammonia, as had been clearly stated by Mr. Hardwich.

In my letter to the *British Journal of Photography*, dated April 28, 1862, writing on the same subject, I said "from careful inquiry as to the exact condition of various baths used here of this kind, I think I am safe in saying that, if a solution of nitrate of sixty or eighty grains to the ounce be made, and to this a solution of nitrate of ammonia be added, taking care to keep the solution very slightly alkaline, the exact equivalent to these so-called ammonia nitrate solutions will be produced. In no single case have I seen baths of this kind become discoloured from use, and what is remarkable, the range of strength for good work is very much increased. At my suggestion, and in order to test the matter for the information of your readers, I requested an operator here to make up a new bath, eighty grains to the ounce, and to use it from day to day without adding any more silver to it until his prints began to show the want of silver. He worked the solution down too low for successful floating, and still the prints showed no symptoms of meanness. The solution at this time showed by the hydrometer thirty grains to the ounce, and I cannot say how much longer it might have been used to advantage."

Any solution of nitrate of silver to which ammonia and nitric acid have been added, as was the case in all the so-called ammonia-nitrate solutions, were to all intents and purposes the same as what is now described in the pamphlet above mentioned—as they were all nitrate of silver and nitrate of ammonia in water—and were made alkaline to produce the effect which is now better obtained by the fuming. Paper floated on a neutral or slightly acid bath will keep white several days, and the alkalinity needed to produce good prints can be imparted to it by fuming to a greater degree without injury to the surface.

What is now sold for the three dollars is what has been written about in the public journals, and has been the property of the public for a long time. I myself have been using a bath with nitrate of ammonia in it for nearly two years, and have been fuming with ammonia ever since last spring, when I received the process from Mr. Henry T. Anthony, who showed me how they used the fuming in their own establishment. It had been my intention to show a few experiments this evening, in illustration of the chemistry of the process, but will content myself with merely stating that nitrate of silver is an oxide of silver combined with nitric acid, and that oxide of silver is soluble in ammonia, or in nitrate of ammonia; it is held more feebly in combination than in nitric acid, and hence will part with its silver to the chloride in the paper more readily than if combined with nitric acid, and the more alkaline is the solution which eventually dries on the film or paper, the more readily is it reduced by light. The solution in ammonia alone is inadmissible on account of the inevitable destruction of the albumen surface, hence nitrate of ammonia, as a neutral salt is better, and the alkalinity can be given by the fuming after the paper is dry. The consumption of silver is the same whether you use 30 grains to the ounce or 120 grains so far as the conversion of the chloride is concerned, but there is some economy in using a weak solution in as much as the liquid on the surface and which dries on also impregnating the paper to some extent is not so rich in silver, and it is probable that the large amount of silver is not advantageous to the production of good pictures.

In conclusion let me express the hope that the members of our infant society will be at all times ready to impart information; for while they are thus advancing the art, they will find that by giving freely they will the more freely receive, and thus in harmony defend themselves from imposition.

ON THE INFLUENCE OF IODIDES AND BROMIDES IN COLLODION, AND ON THE INFLUENCE OF DEVELOPING AGENTS UPON SHORT OR LONG EXPOSURE.

BY M. OMMEGANCK.*

BROMINE was introduced into the daguerrotype process as an accelerating agent, it caused much astonishment when, subsequently, the bromides were said to retard the luminous impression on collodion plates. This diversity of appre-

* Read before the Photographic Society of Philadelphia.

* Continuation of an Article on p. 41, vol. vii.

ciation had its origin in an imperfect method of experimenting. The circumstances were not all taken into consideration. It would not be difficult to demonstrate the causes, but such a discussion, to be complete, would divert us from the object we have now in view, and exceed the limits of an ordinary article. The accelerating action of the bromides in collodion, is unquestionably admitted.

We have established the principle (in our preceding article), that the greater or lesser sensitiveness of iodide of silver depends upon the abnormal dilatation which affects this salt at the moment of its formation in the texture of the collodion, and we have placed it in that category of aggregations, which, in chemistry, is termed the nascent state. Every re-agent which favours this state, and prevents the return of the iodide of silver to the natural contracted state, will be an accelerating agent. It will be much better adapted to produce this effect, if it be itself sensitive to light, and susceptible of being formed in the nascent state. Bromine realizes these conditions perfectly. If we consider that in a bromo-iodized collodion, the iodides and bromides are intimately mixed at the moment of their immersion in the silver bath, by the side of a molecule of iodide of silver (I Ag) is formed a molecule of the bromide of the same metal (Br Ag); perhaps even a double salt is formed; their alternate interposition must necessarily injure and diminish the force of attraction, which tends to bring them to the natural state in nearly the same manner as carbon acts upon the iron of tempered steel; not only does the dilation subsist longer in a compound of I Ag + Br Ag, but the interstices between their molecules, which are of two different forms, are wider, the luminous agent insinuates itself more easily into their medium, and the long and slow vibrations penetrate as well as the more rapid and short ones. As to the more considerable space which we suppose to exist between the atoms I and Ag, and Br and Ag, than between their combinations I Ag and Br Ag, we observe something analogous in the chemical compounds, which are explosive or easily decomposable, inasmuch as the atoms of these bodies are aggregated, contrary to the laws of their natural attraction, and in such manner, as to present a very considerable volume. Experiment has confirmed these theories with regard to photographic operations, for a collodion with equal parts of iodide and bromide is, in general, the most sensitive of any for instantaneous proofs; and, on the other hand, a strong dose of bromide is also necessary to allow of a long exposure.

There exists a great diversity of opinion on the state and kind of re-agents adapted to obtain the best result, as well for ordinary proofs as for instantaneous ones; we believe we may succeed by different methods, and that, above all, proper manipulation is indispensable. Nevertheless, some re-agents are preferable to others. This question seems to be very far from decided, inasmuch as the mode of operating by many distinguished operators is still a secret.

A series of questions which every photographer must frequently put, is the following:—

To which iodides and bromides must preference be given in the preparation of collodion? and must the collodion be colourless, or contain free iodine?

What is the best developing agent, pyrogallie acid or sulphate of iron? Must we acidulate the developing solution with acetic acid, citric acid, formic acid, or nitric acid?

Some of these questions appear to be solved, others still require a long series of experiments.

It is impossible to treat them all within the restricted limits of this essay: we must, for the present, examine the composition of the developer especially.

As the basis of the developing solution, sulphate of iron generally appears to merit the preference, except, perhaps, with dry collodion, where the use of pyrogallie acid is prescribed.

For ordinary productions we employ a bath composed as follows:—

Water	100	parts
Sulphate of iron	3 to 5	"
Glacial acetic acid	1½	"
Alcohol	4	"

For instantaneous pictures we reduce the quantity of acetic acid as much as possible, until we reach the limits at which a fogged picture results: the quantity must be determined at the time, and cannot be subjected to fixed rules. Two solutions are prepared, one of the strength of 1 to 100, the other of 1 to 1,000, and a mixture of the two in suitable proportions employed.

The employment of nitric acid, in lieu of acetic acid, may present many great advantages, especially for instantaneous pictures: it gives greater rapidity.

The employment of formic acid exhibits some remarkable peculiarities. Associated with pyrogallie acid in Mr. Claudet's formula, it greatly accelerates; but, on the other hand, it has the disadvantage of the reactions of pyrogallie acid upon the sulphate of iron. One among other results which its employment yields us in a bath of sulphate of iron of 3 per cent. is, that of fogging the picture completely, if used the same day it is prepared; two days subsequently it yields a good negative in the fraction of a second; eight days after its preparation it has little or no effect, even after an exposure of five seconds. A solution prepared with equal parts of acetic acid and formic acid acts very well the first day, but is rapidly decomposed in contact by sulphate of iron and the oxygen of the atmosphere; it becomes brown only after the nearly complete oxydation of the formic acid.

We do not specify the proportions for formic acid, or for nitric acid, because, as these acids are always diluted with a very variable quantity of water, it is necessary to have recourse to an acidimetric operation in order to ascertain their real value. In taking the sulphate of iron bath, given above as the starting point, we substitute for the acetic acid an equivalent quantity of some other acid. Take two drachms of acetic acid and colour it light red by means of some drops of tincture of litmus, then take an aqueous solution of caustic soda or potassa, and, by means of a graduated measure, put into the acetic acid the exact quantity of alkaline solution necessary to turn the litmus colour to a blue, noting the number of minims employed, and perform the same operation with the formic and the nitric acids; the three numbers found indicate the relative strength of the acids tested. Suppose that five drachms of acetic acid have been neutralized by ten drachms of the alkaline solution; that the nitric acid has required eight, and the formic acid four; then, in the preceding formula, we must replace the 1½ drachms of acetic acid by about 2 of nitric acid, and 4 of formic acid, to have the chemical equivalent. Finally, in taking two or three negatives, we must endeavour to reduce, as much as possible, the quantity of nitric and formic acids, according to circumstances, such as light, heat, state of collodion, silver bath, &c., the effect obtained can alone determine the quantity.

The employment of nitrous, and of acetic ethers, to replace the acids in the iron solutions, may yield excellent results; but it is a most delicate operation: the transformation of a portion of sulphate of iron into acetate or nitrate of iron, by means of the acetate or nitrate of baryta or of lead, may possess certain advantages. Our own experience has not yet given a very decided conviction on this subject.

A SHORT LESSON IN PHOTOGRAPHY.—No. 10.*

THE rules already given for taking an ambrotype are nearly all valid in reference to preparing a negative. The same collodion and the same sort of glass can be employed in both cases. The only differences in the preparation are referable to the time required for the solar impression, to the mode of development, and to the intensifying of the negative.

Time required for the solar impression.—In the negative

* From *Humphrey's Journal*.

it is as absolutely necessary to preserve the same grade of contrast between the lights, middle tones, and shades as in the ambrotype.

It is equally necessary to avoid all fogginess—to preserve the picture as bright and transparent in those parts which are to be transparent as can possibly be effected.

But these are the exact properties of the ambrotype; and now we arrive at that which is distinctly different. If you hold an ambrotype to the light and look through the glass you will easily distinguish objects; you will, in fact, be able to read through the darkest parts, through those parts on which the light has made the greatest impression; whereas, by holding a *correct* negative in the same way, you will not be able to distinguish a single letter through the darkest shade. And the same gradation of opacity is observable in the middle tones and the lights. This is the only difference that exists between a good negative and an ambrotype, and I must consequently impress upon you the necessity of avoiding all attempts at fogging your picture as a means of obtaining negative effect. This is a great error, and one into which you will be liable to fall, from the circumstance that some authors speak of a degree of fogginess as an essential part of a negative.

Now, knowing what the true characteristics of a correct negative are, let us see how we can accomplish the task imposed upon us. The opacity on the sensitized collodion film depends primarily upon the time exposure, and secondarily on the development. But deep opacity of the high lights and transparency of the shades depend upon the intelligent application of both light and the reagents used in development.

An increase of light, either in duration or intensity, will produce more general action on the silver film, and consequently increase the tendency to fogginess; from this circumstance we learn to add more acid in proportion to the sulphate of iron in the developer. If the light be too intense or continued too long, the tendency to fogginess will be unmanageable. The light required must be just sufficient to yield by development a negative possessing clearly and distinctly the three gradations of light, middle tone, and shade above mentioned. As soon as we have managed to arrive at such a result, although the opacity may be far from being deep enough, the rest of the operation is easy enough.

Fix your model to your desire, and, instead of giving six or eight seconds as you did for the melainotype, try ten or twelve to begin with. Now let us proceed to the dark-room. Naturally, the actinic impression being more intense, the developing process will start with more rapidity; and consequently those parts first covered with the developer will be sooner finished, whilst the other parts are not yet finished. Besides this inconvenience it invariably happens, if you pour on your developer as you would collodion, that the force of the falling fluid makes a mark on the film which spoils the picture. Hence arises the necessity of floating your negative plate quite otherwise. For this purpose I recommend you to use always a porcelain or photographic ware dish of about 6 by 8 inches.

Lay your small negative in the front left corner of this dish with the collodion surface upwards; now, holding the dish in the left hand, incline the right side of the dish downwards, and pour into it so inclined a few ounces of the developer, and then quickly raise the dish so as to flow all the liquid at once over the surface. By this means you will avoid all the inconveniences of lines of breakage and other marks referred to. As soon as the plate is thus covered you can place the dish on the shelf or table before you, and can then take out the negative and watch the development. This process may proceed slowly or quickly according to circumstances. If it is tardy in beginning, the time of exposure was too short; if, on the contrary, the action is very rapid, the time was too long, that is with the developer recommended. Supposing the action to be moderate, but quick enough to be properly watched, you may conclude the

time to be about right. Allow the reduction on the film to proceed, increasing in intensity as long as no fogginess supervenes, or until finally the surface by reflected light appears to undergo a retrograde action as mentioned in the lesson on the melainotype. It is high time in this case to stop all further action by quickly and thoroughly washing the plate, and by then fixing in a bath of hyposulphite of soda, and again thoroughly washing.

If, on examination by reflected light, the picture appears still as an ambrotype, and by transmitted light the high lights are tolerably opaque, of course more so than the ambrotype, whilst the deep shades are still transparent, you have a picture from which we can now fabricate a negative in which the opaque parts shall be as dense as you may desire. At present it is not a negative—it is merely the foundation of a negative in which the grades of light and shade are present without the necessary degree of denseness in the opaque parts.

Intensifying of the Negative.—The plate so far prepared may be intensified either whilst it is still wet or at any time after it is dry. In the latter case, however, it becomes necessary to coat the four edges of the collodion film to the depth of one-sixth of an inch with negative varnish. This can be accomplished by dipping the uncut quill-part of a large feather in the varnish and then rubbing this part along the edge slowly—by capillary attraction a sufficient quantity of varnish will flow along the edge, and particularly so if you take care to rub the edge of the plate along that part of the quill where the varnish accumulates by its pendent position. As soon as the varnish has thoroughly indurated, that is, after the lapse of a few hours, the paper is immersed in water and retained there for a quarter of an hour, when it will be in the condition of the wet plate.

Intensifying Preparations.

No. 1.	Water	2 ounces
	Iodide of potassium	to saturation,	and afterwards			
	As much iodine	as it will dissolve.				
No. 2.	Pyrogalllic acid	12 grains
	Acetic acid	1 ounce

Take one drachm of No. 1, and dilute it with seven drachms of water, then flow the plate with this mixture, taking care to keep the fluid moving, by pouring it off and on all the while. By degrees the collodion film assumes a yellowish tone; at this stage you can wash the plate thoroughly and then proceed to the final operation.

Take one drachm of No. 2, and dilute it with seven drachms of water, to this add twelve drops of the nitrate bath and shake well, then keep pouring the mixture on and off the plate until the proper degree of opacity has been attained.

It sometimes happens that you have to proceed a second time with No. 2, before the opaque parts are sufficiently dark. I must repeat: be careful to shake the mixture well before you use it. Now wash thoroughly, dry, and finally varnish. Your negative is complete.

By this process of intensifying there is not much difficulty in converting an ambrotype into a negative; but such a negative will be defective from the fact that it possesses no intermediate tones; it is a mere contrast between intense blacks and pure transparent parts. On this account we are obliged to give more time, that is, more light, in order to produce a more general actinic effect over the whole surface of the plate, which, on development, yields a foundation-negative, that will receive by the intensifying solution any amount of deposition.

PREPARATION OF GUTTA-PERCHA PAPER.

BY ALEXANDER ARNSTEIN.

The gutta percha is cut in small pieces, and put in a wide-mouthed bottle, wherein benzole is poured sufficient to make a thick solution. The bottle is then put into a vessel containing water, and the whole placed on a stove, or near the

fire, stirring the solution from time to time. When dissolved, it is poured in the filter to draw off the liquid; what remains on the paper forms a paste that must be kept in a cool place. From this paste 6 to 10 grains are taken to the ounce of benzole (it depends on the moisture it contains). The bottle containing the solution is placed in warm water. A clear solution is obtained, which, if rightly made, looks like newly-iodized collodion.

Paper.—The paper is put in this solution, and left for a minute or two. Several sheets can be put in, being careful to avoid air bubbles; they are then hung up in a warm, airy place, and left so until the gutta percha is set, which takes a day or two; if not set, opaque spots will be seen when salted; although it does not affect the paper, it is better to avoid it.

Salting.—Ten grains of chloride of ammonium to the ounce of water. The paper takes the salt solution well, but I think a grain of isinglass to the ounce of silver is a great improvement to the tone of the picture.

The Silver Solution contains 60 grains to the ounce of water.

Washing.—As usual.

The Acetate Bath contains 1 ounce of acetate of soda to 6 ounces of water.

Toning Bath.—One grain of chloride of gold, 20 grains of borax to 8 or 10 ounces of water, prepared a few days before using, or any other toning bath, but must be weak in gold.

Fixing Bath.—One ounce of hyposulphite to 6 ounces of water.

Washing.—Two or three hours to be on the safe side.

The prints, when passed under the rolling press, look as if printed on slightly albumenized paper. Seeing the defects of photographic paper, I think that a waterproof solution will be applied to all kinds of paper. I hope that photographers will not be slow in giving to this process a fair trial. If any one should wish for a few pieces of prepared paper, and will send a directed stamped envelope, I will enclose a few pieces for cartes, as I cannot afford to send larger.

Ambleside, March 21, 1863.

THE STEREOGRAPH AND THE STEREOSCOPE.*

But if the single eye has this property, then the retina is not a surface—it must have a certain thickness of such a constitution as to be sensitive to the focal impression on any part of it; and if it has this sensitive structure throughout a certain thickness or depth, then the secret action of vision at long and short distances is solved. The problem, therefore, to be demonstrated seems to be, to ascertain, in the first place, what ought to be the thickness of a sensitive retina to comprehend pictures of objects between the extremes of the minimum distance of distinct vision and the maximum at an infinite distance, and then whether such a thickness exists. With an ordinary lens this is an easy task. The greater the power of the lens, the less will be the difference between the length of the principal focus and that of a very near object. The same law will prevail, with certain strictures and modifications, with the crystalline lens in the eye. But the method which I adopt, for ascertaining the capacity of the eyes for different focal distances, is altogether independent of the ordinary laws of optics, or at least it is developed upon totally different data from those previously applied to such discussions. The capacity referred to can be found in the following manner:—Take two words, for instance, *London*, printed in the same type, and paste them on a sheet of paper on the same line, so that the distance apart from *L* to *L* in either word shall be exactly the distance between the centres of the two eyes. Then on a line, parallel with the former, and distant from it one-quarter of

an inch, take two other words, as for instance: *Geneva*, printed in the same type (although this type may be quite different from that with which *London* was printed), and paste the word *Geneva* so that *G* is exactly beneath *L* of *London* on the left side, but let the distance between *G* and *G* in the two words *Geneva* be less than that between *L* and *L* in the two words *London*, as in the following example:—

London.	London.
Geneva.	Geneva.

Let the word *Geneva* to the right be loose (not pasted), so that it can be moved nearer or farther off. Now superimpose these words strabonically. It will be found that the word *Geneva* can be moved but a short distance to the left before it becomes impossible to superimpose *London* on *London*, and *Geneva* on *Geneva* at the same time. Be careful to obtain the exact point where the power of superimposition ceases. Then measure off, with a pair of compasses, the distance between *L* and *L*, as also between *G* and *G*, and ascertain the amount of their difference. Call this difference *Z* (equal to lateral difference). Next ascertain the distance of the eyes from the paper, when they see distinctly. Then say: As the distance between the centres of the eyes is to the distance between the eyes and the paper, so is one-fourth of *Z* to *X* (the longitudinal distance). A second proportion, as follows, will give the thickness of the retina. That is: As half the distance of distinct vision is to *X*, so is the distance between the retina and the crystalline lens to the thickness of the sensitive retina.

If the difference, *Z*, be greater than one-fifth of an inch, my own eyes cease to superimpose the objects with tolerable clearness. Assuming this quantity, then, as the limiting difference, and twenty inches the distance of distinct vision for my eyes, and, moreover, half an inch the distance of the crystalline lens from the retina, we have the following proportions:—

Inches.	Inch.	Inch.	Inch.
As 2·5 :	20 :	0·5 ($\frac{1}{2}Z$) :	·4 (<i>X</i>)

Inches.	Inch.	Inch.	Inch.
2ndly, As 10 :	·4 :	·5 :	·02 (thickness of the retina).

From this calculation I infer that, if the retinae of my eyes are sensitive not alone on their surface, but to the depth of two one-hundredths of an inch = one-fiftieth of an inch, then these retinae are in a condition to bring all objects to a focus whose distances vary from 20 inches to an indefinite quantity, and consequently to see all objects between these extremes. If an object be nearer than 20 inches, the conjugate focus will be longer, or beyond the retina; still such an object will be seen (although indistinctly, because the rays pass through the retina, just like an object viewed on the ground glass when out of focus and too near to it).—The calculations of Olbers, derived from quite a different source, that is, by taking into consideration the radii of curvature of the crystalline lens, its refractive power, its distance from the retina, and the refractive powers of the other media engaged in producing vision, resulted in obtaining ·143 of an inch as the difference between the conjugate focal distance of an object four inches remote from the eye, and of an object at an infinite distance.

Eyes that are endowed with the power of seeing distinctly at the distance of four inches, as also at an indefinite distance of a mile or more, would certainly be able to superimpose objects placed at a greater disparity apart than I can; and if there are such eyes so remarkably endowed, then the quantity which Olbers obtained would coincide in some measure with the quantity obtained by my method, which can be more relied upon, because it is founded on the capacity of the eye as derived from absolute experiment, and not on the assumption—that if the eye were in every respect like an ordinary refracting mirror, then optically

* Continued from p. 615, vol. vi.

from given data we should obtain a given result. I must confess, however, that I have not seen any eyes possessing the capacity in question from which the deductions were obtained. Eyes that see objects distinctly at the distance of four inches are abnormal, and are incapable of seeing objects distinctly at very great distances; so that the capacity, that is, the difference between the minimum and maximum focal distance in most eyes, is, probably, nearly the same quantity, and that at the very utmost it probably never exceeds the one-fiftieth part of an inch. I think it will not exceed this quantity from another fact, namely, that, having exercised my eyes exceedingly in experimenting with the superimposition of objects at variable distances, the faculty of discriminating the amount of this capacity or quantity has become very sensitive.

If, then, the retinal layer has the thickness of one-fiftieth part of an inch, and if the structure of the retina is sensitive from the anterior to the posterior part, that is, from the hyaloid membrane on one side to its contiguity with the choroid membrane on the other, then the eyes are endowed with the power of distinct vision at variable distances *without changing* the shape of the crystalline lens, or its position in the eyeball. In the first place there is no authority, derived from the anatomy of the eye, to conclude that the crystalline lens assumes a different shape when viewing near or distant objects. Secondly, there is no authority, derived from the science of optics, permitting the conclusion that the different layers of the crystalline lens act independently of each other, or in partial combinations involuntarily for different distances. To admit such a phenomenon would be equivalent to admitting that the separate lenses of an achromatic combination had each its separate focus, at which a separate image would be produced. Thirdly, there is but little authority that will warrant us to conclude that the crystalline lens has a motion in the eyeball, produced by the ciliary muscle or the erectile tissue of the ciliary processes.

Such motion cannot be demonstrated to exist; the conclusion alone has been drawn, that if such a motion did exist, it might perhaps be produced by such means, but certainly not by the action of the muscles of the eyeball. It seems to me, therefore, a reasonable conclusion to reject all hypotheses which have so little ground for adoption, and to admit one which possesses all that is desired to satisfy the requirements.

It has been proved, by microscopic observations, that the retina is not a surface, that the retinal expansion is quite appreciable in depth, consisting of several layers of nervous fibres, vesicles, granules, and rods, quite transparent and in continuity with each other: so that it becomes a conclusion warranted by the data, that the conjugate foci of objects at different distances in front of the eye are to be found at relatively different distances among the radiating bacillar projections, and nervous fibres that make up the substance of the retina, and that the impressions thus made at different distances on either eye will, by the crossing of the nerve fibres at the optic commissure, or elsewhere, or otherwise, produce the solid picture of the reality in the sensorium.

The calculations of Olbers furthermore presuppose that the eye changes its form some way or other in order to view the extremes of minimum and maximum distance; but I maintain that, as indicated by the experiments of superimposition, the eyes can view minimum and maximum distances of great diversity at the same moment of time; for instance, the moon and a church-steeple can both be seen at the same time if situated in a proper angular condition for the purpose. Now, if this be so, if it can be proved to be so, it is evident that the eye, in the case supposed, *does not change* its form; and if it does not change its form, then the retina must consist of a transparent thickness for the reception of the conjugate foci of external objects; and the admission of both these properties of transparency and thickness of medium is simply the admission of two well-known facts; and, these facts being admitted, the rationale of vision at differ-

ent distances, and of solid pictures on the retina conjugate to objects in nature, or to their representation on the stereograph, is manifest and intelligible.

A person with one eye can never see perfectly the solid character of objects as comprehended by the operation of two eyes; for the superimposition of the two sides of an object cannot be performed by one eye. Nevertheless, a single eye can take cognizance of distance, which it could not do if the retina were simply a surface. If this be so, then the visual impression of lateral and longitudinal distances will give at the same time a conception of solidity, deduced probably from, or corroborated by, the sense of touch and by experience.—*Humphrey's Journal.*

THE NITRATE OF SILVER BATH.*

The nitrate of silver bath, undoubtedly, is the photographer's greatest difficulty. Being unfortunately required in large quantities, and of an expensive material (its preservation in a good working condition is one of the grand desiderata of our art), too much care cannot be bestowed upon its preparation. Perfectly pure ingredients are indispensable; and carefully re-crystallized nitrate of silver, obtained from a reliable source, should alone be employed. Some samples of the commercial nitrate of silver are found to answer fairly, but, as a rule, it cannot be depended upon. A good and easy test of the purity of this article, is the suspension of a piece of litmus paper in the bottle containing the crystals. If, at the expiration of an hour, the paper remains unchanged, the absence of free nitric acid is indicated, and, along with that, it may be presumed, of the other impurities of the adhering mother liquor. Good re-crystallized will always stand this test, but it is very rare for the commercial to do so. Fused nitrate of silver the writer has always maintained to be a great mistake, because of the probability of its being made from the mother liquor, from which a crop or two of crystals have been taken—the manufacturer thus being enabled to use up advantageously all his solution—and, therefore, instead of its being the purest kind, it is generally the very reverse, with the additional danger of its being further injured by the presence of nitrate of silver from carelessly over-heating during fusion. This fact is now so fully recognised, that the employment of this form of the salt has almost ceased. The objections, of course, do not apply to the carefully fused sample, prepared under the watchful eye of the well-skilled manipulator, but even then it possesses no advantage over the re-crystallized.

So much difference of opinion prevails with regard to the bath being *neutral* or otherwise, that a set of very careful experiments were instituted to ascertain what were the real facts of the case; and, in order to guard against error, the experiments were repeated three times, the first and second being a year apart. I would strongly advise photographers to make trial of the matter for themselves, for they would find in the knowledge and confidence thereby obtained an ample compensation for the little trouble occasioned. There is, however, much uncertainty in these photographic experiments, unless great precaution be used to guard against error—the danger of misreading or misinterpreting the results of our experiments, arising from the complexity of the subject with which we are dealing, and our proneness to overlook or disregard some seemingly trifling condition—a trifle which may turn out to be of the utmost importance. If photographers were more careful experimenters, there would not be such contradictory statements put forth, nor would such a mass of crude hypotheses pass unchallenged as are now met with among us.

Passing on to the experiment, I will detail, as clearly as I can, the method employed, and the results obtained in my hands. In the first place, it must be clearly understood

* From Ponting's "Photographic Difficulties." We have generally condemned the use of acetate of silver in the bath; but, for the purpose of giving impartially both sides of a question, upon which we have recently had many questions, we reproduce this interesting chapter.

that the collodion used in this and all other experiments, was my own make, and at its ripe and colourless stage. With other collodions, it is possible the results may be different.

A neutral bath being necessary to start from, it was obtained by dissolving two ounces (avoirdupois weight) of re-crystallized nitrate of silver, in thirty ounces of distilled water, very carefully distilled at a low temperature over a gas flame. The solution was then divided into two equal portions, of fifteen ounces each, and placed in perfectly clean and new bottles, to one of which was added a small portion of oxide of silver, made by dissolving a few grains of the same nitrate of silver in distilled water, and precipitating the oxide with liquor potassæ, P.L. (solution of caustic potash of pharmacopœia strength) ascertaining, first, that the liquor potassæ was perfectly caustic, by finding that it would not effervesce on the addition of a dilute acid. The oxide of silver was then thrown on a filter, and washed with distilled water. In the first experiment, in March, 1859, I mixed together five ounces of each of the two solutions of nitrate of silver, used the resulting bath, and obtained a clean and satisfactory picture. I then added one ounce more of the solution with the oxide, and on again taking a picture, found it foggy from the alkalinity of the bath, its neutral condition being restored by adding another ounce of the simple solution of nitrate of silver. On repeating the experiment, however, in March, 1860, a different result was obtained. The two solutions of nitrate of silver were made as before; but it being, at the time of preparation, very dull weather, quite unsuited to experiments of this kind, the oxide of silver remained on the filter several days, having three or four portions of distilled water poured over it each day; and in this way, I believe, all alkalinity, from the presence of liquor potassæ in the precipitate, was entirely got rid of. The solution of nitrate of silver saturated with this oxide, while still moist, and allowed to stand over it several days, with frequent shaking, gave a clean picture free from fogging, when it was used without any admixture of the other solution. Thinking, from the discrepancy between this and the former experiment, and from the recorded experience of others, that some fallacy lurked in the experiment, a further additional trial was made, and a precisely similar result obtained. It would thus seem that the alkalinity, deemed to arise from the oxide of silver, is really due to the presence of a minute portion of the potash solution adhering to the oxide.

Having in this way obtained a perfectly neutral bath, which had neither acid nor alkaline reaction on test paper, further experiments were made to ascertain the effect of the addition of *acetate of soda* and *acetic acid* to the bath. For this purpose a pair of landscape lenses, fitted to a binocular stereoscopic camera, were used, the lenses being $1\frac{1}{2}$ inch diameter, five inches in focal length, and stopped down to three-eighths of an inch. This is a very convenient camera for such experiments, as it enables one easily to try the result of two different times of exposure under the same circumstances. The object was a lot of dingy old chimney stacks, roofs of houses, and a distant church tower, visible from the operating room, giving near and distant objects, and brightly illuminated by a March sun; care being taken to select a day when the light was uniform, otherwise these comparative experiments would be of little value. A plate that had been immersed in the above neutral bath was exposed on one half of its surface three seconds, and on the other half six seconds, developed with the usual one grain to the ounce pyrogallic developer, with acetic acid. Ten drops of solution of acetate of soda* were added to the bath (of about ten ounces), and a pair of negatives taken, giving precisely similar exposures to those of the first pair. Five drops of glacial acetic acid were now added to the same bath, and a third pair of negatives taken, keeping, of course,

to the same exposure, each pair thus consisting of a negative taken in three seconds, and one taken in six seconds. The three negatives were printed together, on one piece of paper, the first negative having to be screened about one-fourth of the time, to prevent its being over-printed. A descriptive account of the negatives is annexed, in a tabular form, for easy reference.

A. NEGATIVE No. 1. B.

THREE SECONDS' EXPOSURE.

A weak purplish sky; all the details of the illuminated parts of the picture are given, with some of the brighter portions of the shadows; no details in the deep shadows; prints dark and heavy.

Exposure too short.

SIX SECONDS' EXPOSURE.

This is a good negative of a purple red colour, full of half tone, and details of the dark parts well out; a little wanting in force, but furnishing a good print.

Exposure about right.

C. NEGATIVE No. 2. D.

THREE SECONDS' EXPOSURE.

In this the effect of the acetate of soda is very apparent; sky intense; a much better negative than the one above; no details in the deep shadows; prints dark, but brighter than the one above.

Exposure too short.

SIX SECONDS' EXPOSURE.

A very intense negative; a black sky, which could not be printed through; details of the dark parts well out, but being somewhat over developed, it prints with too strong a contrast between the lights and shadows.

Exposure about right.

E. NEGATIVE No. 3. F.

THREE SECONDS' EXPOSURE.

This is a good and vigorous negative; sky orange red; the details are all well out in the dark parts; half tones good; gives a good and forcible print, and with another second's exposure, would have been, beyond question, the best of the lot; as it is, it is doubtful whether this or the B of No. 1 is the better.

A little under exposed.

SIX SECONDS' EXPOSURE.

This is a very intense negative, with orange sky, and the other portions of the picture of a red tinge; takes a long time to print; the sky weak from exposure, and prints through, but the other parts vigorous and full of detail and half tone.

Over exposed.

To sum up the results of these trials, it is clear that the addition of acetate of soda and acetic acid does not make the bath work slower. In fact, if these experiments may be relied upon, it is shown that the action of the bath is thereby accelerated, for the pair of negatives No. 3, are very much better than No. 1 pair, and there would be considerable difference of opinion among photographers as to whether the negatives B or E were the better, though the latter was exposed only half the time of the former. Although I had, for years, employed and recommended to others this method of making the bath, I was not at all prepared for this result. For myself, I had long been abundantly satisfied, as the result both of my own experience and that of others, that this preparation furnishes the operator with an organic matter, not injurious to the bath, which gives him a controlling power over it, so as to enable him to increase or diminish the intensity of his negatives; and, in addition to this, there is plentiful proof that the bath is, by its use, preserved in good working order for a longer time than by any other method.

This accelerating action of acetate of soda with acetic acid (for they should always be used together, as these experiments demonstrate), being quite unexpected, some experimental negatives taken a year ago, were examined, to see

* Acetate of soda, 130 grains dissolved in one ounce of distilled water, to which is added sufficient glacial acetic acid to make it redden litmus paper, say ten drops.

if they would bear out this statement; and, on submitting them to careful inspection, there could be no doubt of the fact. The trials were made at the time to demonstrate the increase of intensity obtained, without adding to the exposure; and, as they proved that no further search was made, and as no prints were taken from them, the difference was not so manifest. In order still further to be satisfied that the result in question was not due to an accidental increase of light in the favoured negative, a further set of experiments was made, with a fresh sample of collodion about a month old (the previous one being about nine or ten months old), commencing with an entirely new neutral bath, and, altering the order of the previous experiment, acetic acid alone was added for the second trial, the third attempt being with both acetic acid and acetate of soda. The result was quite confirmatory of the first set of experiments. The time of exposure was increased to four and eight seconds respectively. The four seconds exposure was abundantly long enough for the first and third plate; the one with acetic acid alone was much slower than the other two; but the third negative, with acetic acid and acetate of soda, was again, unmistakably the best of the lot. Of the negatives with eight seconds exposure, the first, with neutral bath, is so much over-exposed as to be useless; the second, with acetic acid alone, is about right; the third, with acetate of soda and acetic acid, is considerably overdone, but gives a tolerably good print notwithstanding. The slight difference between this negative and the corresponding one of the former experiment, is probably due to the fresh sample of collodion, but is confirmatory of previous experience, which showed that the operator might, with this bath, much increase his exposure, to get out any very dark portions of the pictures, with greater impunity than when using a neutral, or nearly neutral, bath.

PHOTOGRAPHS IN PRINTING INK.

[Mr. John Pouncy, of Dorchester, has addressed to the Editor of the *Times* the following letter, in answer to one from Mr. J. W. Osborne, as it was not inserted in that journal he asks us to publish it. As we gave an abstract of the correspondence in the *Times*, we, in fairness, insert Mr. Osborne's reply. We must add, however, that we are not aware of the existence of any evidence which proves that Mr. Pouncy applied the principle of the *transfer*—the question really at issue—before Mr. Asser, Mr. Osborne, or Col. James. Mr. Pouncy's first published carbon process had no relation to the use of printer's ink.—Ed.]

I claim your indulgence for a few lines in reply to the letter of Mr. J. W. Osborne, which appeared in the *Times* of the 17th inst., with regard to my newly-patented process for producing photographs in printer's ink. Notwithstanding all that is therein stated with such "official authority," I, as an honest Englishman, not only claim the "earliest conception of the idea," but also the practical working out of the same to the production of a picture, direct from a "negative," hitherto unequalled in any system of printing photographs in carbon. This I demonstrated before a meeting of the London Photographic Society at King's College, on the 4th of November last; and although Mr. Osborne seems to think so little of the specimens then exhibited, how is it that, with all the resources at their command, neither he nor Colonel James has responded to the challenge I then gave to produce anything of the kind in this department of carbon printing? My original carbon process was first brought out in 1858, and publicly discussed before the Photographic Society of London in January, 1859—a fact which Mr. Osborne altogether ignores, and this included a process on stone, from which copies could be printed in printer's ink. After this followed M. Asser and others; but I have failed hitherto to see that they have attained to anything more in this direction than photolithography, and that only in copying prints and maps. The printing of Domesday Book from stone or zinc is based on the principle of my original carbon process, as acknowledged in the preface to Sir Henry James's book. There is, however, a vast distinction between copying line engravings, maps, &c., and photographing pictures from nature or life; the former requiring nothing but black and white, while the other must be composed of the minutest gradations of tone. Here lies the

value of my "special method," as Mr. Osborne is pleased to style it; and that my "half tones" are equal to photographs produced by the nitrate of silver process from the same negatives, I can assert, without fear of contradiction, before any competent and unbiassed tribunal. Those who have any misgivings as to the results at which I have arrived will have ample opportunity of satisfying themselves, by an inspection of the specimens which will be shown at the approaching exhibition of the Photographic Society of Scotland.—Your obedient servant,

JOHN POUNCY.

Dorchester, February, 18, 1863.

Proceedings of Societies.

NORTH LONDON PHOTOGRAPHIC ASSOCIATION.

THE Annual Meeting of this Society was held in Myddelton Hall on the evening of Wednesday, March 18th, Mr. G. DAWSON in the chair.

The minutes of a former meeting having been read and confirmed, Miss Barfoot and the following gentlemen were elected members of the Society:—Messrs. G. Hooper, W. Braine, J. Davis Burton, Wm. Henry Mertens, Jas. Mitchell, and Ed. George.

MR. G. WHARTON SIMPSON exhibited a specimen of enamelled paper for photographs, which he had received from Herr Liesegang of Elbertfeld, who stated that it was regarded with much favour in Germany. Mr. Simpson also exhibited some card portraits printed thereon, which were very brilliant and rich in tone.

THE CHAIRMAN called especial attention to the depth and richness of the prints, which were generally admired.

THE SECRETARY then read the annual report, which congratulated the members on the satisfactory position of the Society. The financial statement showed that at the last annual meeting there was a balance in hand of £15 6s. 9d.; and that after paying all expenses, the balance now presented was £21 18s. 7d.

The report having been read and adopted, the meeting proceeded to the election of officers. Whilst the routine proceedings necessarily were in hand,

MR. SIMPSON, at the request of the Chairman, entered into a few further explanations regarding the enamelled paper, which seemed to excite much interest. He stated that on examination he found that a surface of albumen rested on a surface of enamel, and that the image was confined to the albumen surface. A piece of the paper where an air bubble had occurred in sensitising, illustrated this, for the albumen had been removed during fixing and washing, but an enamelled surface was still found. He had treated the paper the same as albumenized paper, floating on a 60-grain bath, toning in a bath of gold and acetate of soda, and fixing and washing as usual. With each of the pictures he had printed he had also brought a print on ordinary albumenized paper from the same negatives. The superiority in depth and richness of tone in enamelled prints was very striking, whilst the fine surface unquestionably rendered more detail. So far as it was at present possible to judge, the paper would be very valuable for card portraits. He ought to add that it was quite exempt from meanness.

Some conversation on the subject followed, especial attention being directed to the freedom from meanness, and a general opinion in favour of the paper was expressed.

MR. MORLEY showed some very fine negatives with prints therefrom. They were produced by plates well washed after sensitizing, then coated with dilute albumen, dried, and subsequently coated with a solution of gallic and tannic acid.

MR. MOENS having relieved the Chairman of his duties, MR. DAWSON read a brief paper on the lenses used for instantaneous photography, in which he expressed a strong preference for the use of single lenses with small aperture as giving so much better definition to the distance as well as the foreground, instancing many of Mr. Wilson's slides as illustrating the value of this mode of working,* and exhibiting many of the slides in

* It is a mistake to imagine that Mr. Wilson uses a small aperture in instantaneous photography. Every photographer will, of course, use an aperture as small as the condition of the light, the nature of the subject, and the sensitiveness of his chemicals will permit; but the average aperture used by Mr. Wilson with a lens of five or six inches focus, is about half an inch or five-eighths, and he has recently been using a new form of single lens constructed for him by Mr. Dallmeyer, with the express purpose of giving good definition with a wide aperture.—Ed.

question. These were marked at the back with the name of the lens with which they were produced; a few of the earlier slides were produced by French single lenses, a couple by Jamin's quarter-plate portrait lens, several by Ross's $\frac{1}{4}$ inch focus single stereo-lens, and the remainder by Dallmeyer's new form of single lens; the size of the stop used, however, was not stated.

Mr. Dawson also showed one of Harrison's new globe lens which he had been trying. The equivalent focus was about $10\frac{1}{2}$ or 11 inches; he had tried one or two negatives, but the day was very unfavourable for such a test. An image consisting of a test object of a series of vertical and horizontal lines, was given quite free from distortion and well defined on a 12 by 10 plate; an hour's exposure being necessary in the very dull light of that morning. An image of the same object on the same sized plate was equally free from distortion, and as well defined with one of Ross's new triples of 9 inches focus. A pair of views, chiefly of house tops, taken with the two lenses in question, were also exhibited, in these the advantage appeared to be possessed by the lens of larger focus. They were produced with similar stops in about the same time, and both on 12 by 10 plates.

Mr. Dawson in answer to Mr. Simpson, said his test sheet was about 23 inches long.

Mr. Simpson remarked that in producing an image so large in proportion—about half the size of the original—the focus became of course practically lengthened. In answer to a question Mr. Simpson stated, that the price of the lens now exhibited was, he believed, £15. Mr. Martin said he had understood it to be £19.

After some further conversation, the names of the officers elected for the ensuing year were announced as follows:

President.—Charles Woodward, F.R.S.

Vice Presidents.—G. Shadbolt and G. Dawson.

Treasurer.—D. W. Hill.

Committee.—G. Wharton Simpson, W. Hislop, J. Shave, W. W. King, W. J. C. Moens, F. Bedford, T. A. Barber, E. W. Foxlee.

The proceedings then terminated.

PHOTOGRAPHIC SOCIETY OF PHILADELPHIA.*

THIRD stated meeting, held Wednesday, February 4th, 1863. Meeting called to order by President C. GUILLOU.

The room committee reported having completed the furnishing of the room, and urged the members to donate to the library such books and back numbers of the journals as they could spare, and to make use of the walls of the room to display photographs of interest, which they could change from time to time and thus by variety keep up the attraction. They report that to Mr. Hugh Davids they are indebted for the gift of a book-case; and to Mr. Pearce for a bulletin board.

Corresponding Secretary COLEMAN SELLERS read a letter from Mr. Robert Shriver, Cumberland, Md., thanking the Society for the compliment paid him in electing him corresponding member. Also a letter from Mr. Charles Waldack, Ghent, Belgium, full of kind wishes. One from Mr. Black, of Boston, promising some large photographic views, and giving a short history of the spirit photographs. One from Messrs. Seely and Bartlett, of New York, offering to donate to the Society the back volumes of the *American Journal of Photography*.

Messrs. Robert Wise, and Robert Sturges, were elected members.

The SECRETARY, Mr. J. C. BROWN, then read a letter which had been published by Dr. Childs, giving his account of the spirit photographs, and having his first proof of their genuineness in the fact that the New York Photographic Society pronounced them a humbug, as in the case of Galileo and others of the old philosophers in the days of darkness, and the discussion of the learned bodies of those days. During the reading of the paper quite a number of the spirit pictures were passed around for inspection, and were examined with interest, but did not strike any of the members present as convincing proofs of their being genuine. Various ways of producing the pictures were proposed, but as there were no believers in spiritation present, the argument was rather one sided, and the matter was soon dropped.

The PRESIDENT exhibited a number of etchings by Spackman, as an introduction to some prints made by a company in

New York, and which are to be printed from copper type said to have been made by a new process. He said he would not give any further detail of the process used further than that a glass was coated with some compound (as on the plan of Pretsch, which was, he believed, gelatine and bichromate of potash), and then dried. This exposed to the light under an engraving or an etching on collodion films, and then soaked in a liquid which would swell up all but the lines; on this surface the copper is printed direct, and this copper plate used as a block to print from. A sample of the copper plate was shown.

COLEMAN SELLERS read a paper on "Secret Formule," which was intended mainly to show that a pamphlet published in New York, and sold for three dollars, was descriptive of what had been long known, viz., that nitrate of ammonia added to the silver bath would allow a weaker solution of silver to be used for albumen paper, and the fuming with ammonia would surpass the requisite alkalinity without injury to the surface.

The PRESIDENT passed around for inspection some of the negatives made at the Imperial printing office of Vienna, and which consisted of films separated from the glass. He supposed that gelatine was the substance used, but the gentleman who had brought them to him was no photographer and could not describe the process, although he had seen it at Vienna.

The SECRETARY exhibited some prints from negatives made into a six-inch focus globe lens, and stated that he had heard that these new lenses were considered quick workers, but he did not think so. That he in company with Professor Fairman Rogers had taken a short photographic excursion, and that he had taken his six-inch Harrison globe and a Voigtlander orthoscopic lens of ten or eleven inch focus. He had exposed five or six plates, but that the day was so cold that the films were frozen (he was working wet collodion), and that with the Voigtlander he could get better definition with a large opening and could work quicker than with the Harrison. He merely wanted to say that he had been disappointed in the rapidity of the working, and did not think he could secure clear definition except with the very smallest stop.

Professor ROGERS was of opinion that the test of that day was hardly a fair one, as it was very cold, and his own dry plate seemed to take longer exposure than usual. He alluded to the freezing of the wet films, and said the crystals were very beautiful thus formed. He had never had much experience with the working of wet collodion in cold weather, but presumed Dr. Hayes's experience in the Arctic regions would throw some light on it.

Mr. J. P. SARGEANT said that Dr. Hayes had laboured under many disadvantages, not having any practical knowledge of photography, but that his negatives were quite good considering the circumstances, and had not heard him complain of any trouble except what were incidental to young beginners.

During this conversation, Mr. Hugh Davids, who is a landscape painter and has a room over that of the Society, retired for a few minutes, and returned bringing with him a negative and print from it, which he had made with an eight-inch Harrison globe, at six o'clock p.m., in the latter part of August last; the subject was principally foreground of weeds and stones, with dense masses of trees for the background; size of plate 8 by 10, exposure, wet, forty-five seconds; it was fully timed. He said he considered the globe lens as a quick worker, and had used a large opening in making the picture exhibited, which was very sharp in all parts of the field.

COLEMAN SELLERS said he had tried the identical lens in presence of Mr. Browne, and had produced a good picture on a cloudy day in less than one minute; he did not think them slow workers, but hoped some of the gentlemen present who had these lenses would give some account of their experience with them.

Mr. E. BORDA had been using the globe lens for a long time, and considered them very quick; with the smallest stop less than one-eighth of an inch diameter, he had produced a good picture wet, in a fraction of a second, and with tannin plates in fifteen seconds by fuming. This led to many questions as to the particulars of his fuming, which Mr. Borda answered substantially as follows:—

The plan of fuming plates had been suggested to him by Mr. H. T. Anthony, who had tried it some two years before he told it to him; but that Mr. Anthony fumed his plate before exposing. Mr. Borda fumed after exposing and before developing. He now fumed at least nineteen out of every twenty plates exposed; he could accomplish two important results: first, he could diminish the time of exposure; second, he could

* From the *American Journal of Photography*.

so modify the development as at all times to secure good detail in the foreground, while his clouds and distances were well preserved. He used ammonia diluted, and fumed for a longer or shorter period, according to the effect he wished to produce. When the exposure had been very short, he "gave it a pretty stiff dose;" but with long exposure he would not let it be but a few seconds in the gas from dilute ammonia; say one ounce of concentrated ammonia to two ounces of water. The development was conducted by wetting the plate, then using weak pyrogallie acid and a great deal of acetic acid; he had operated on a plate in this manner for one hour without staining or fogging it in the least. He could not, without an actual exhibition of his mode of operating, give a full account of time and quantities, as both were dependent on experience and practice, but he was very cautious in his manipulation, using his silver drop by drop, so as to feel his way with the development.

Mr. FASSITT had been present some few days ago when a twelve-inch Harrison globe lens were tried. He had seen three exposures made, as objects across a street, that with forty-five, forty, and thirty seconds' exposure the negatives were over-exposed; he should have judged seventeen seconds would have been ample time; he had never considered them slow workers.

Professor ROGERS was of opinion that in all experiments to determine time, the slide of the shield should be marked, and then when closed to begin with should be opened one inch at a time, giving from three to five seconds difference between the spring and the developed plate would show what time was best for the subject.

The PRESIDENT asked if any of the gentlemen present had tried formic acid as a developer? He had had given to him on that day a translation from one of the German journals (which one he did not know), describing a quick developer of 200 parts water, 14 parts pyrogallie acid, 26 parts formic acid, and twenty parts alcohol. He had tried it, but not enough to judge of its value.

Mr. DAVIDS had been using formic acid with the proto-sulphate of iron, and thought it an improvement.

COLEMAN SELLERS had used it for a great while, but did not think it was of very marked advantage; he was of opinion that in the formula given by the President the omission of any retarding acid would make the picture flash up quick, but would be apt to produce stains, formic acid not being a very powerful reagent, except when warm, as one of its properties was to reduce silver from its salts when hot.

The PRESIDENT had been promised by next meeting some copies of "greenbacks," producing the colours in the bank note, and that (as had been represented to him) in so perfect a manner as to defy detection.

The meeting then adjourned.

Correspondence.

PHOTOLITHOGRAPHY.

DEAR SIR,—I beg to enclose you a specimen of a transfer exactly as it was taken from the ink. The method by which it is obtained is at once simple and easy, securing the minutest detail, without the labour and risk of washing off the gelatine that has not been acted on.

After a print is taken from the printing frame, it is laid on its back on the surface of clear cold water, and allowed to remain till the gelatine can be traced on the surface. It is then removed and laid face down on a sheet of plate glass which has previously received a thin coating of greasy ink, and gently rubbed over the back, so as to bring the drawing into close contact with the ink. On removal, it will be found that the ink has attached itself to those parts only which have been acted on by light, the ground remaining perfectly pure and clean. If the quantity of ink is found not sufficient the process can be repeated till it is so. The coating of gelatine should be strong, and the paper, which I find gives the finest results, is albumenized, the surface of which has been rendered insoluble by straining.—I am, Sir, yours respectfully,

A. WOOD.

[The transfer received is clean, crisp, and sharp; and altogether, so far as our eye—not practised in lithography—can perceive, very good.—Ed.]

PHOTOGRAPHY IN NEW YORK.

MY DEAR SIR,—I owe many apologies to all my friends for shortcomings. My excuse is illness. Pertinacious attacks of pleurisy and bronchitis have confined me to the house for some months, and photography has been at a discount. My amusement has been printing a newspaper, of which I send two first numbers, and will send regularly. This sheet is "club" entirely, and we hope to print articles from the Club which will be worth reading.

In regard to the "Brass Toning," Coleman Sellers, Esq., writes me that he has introduced it into the photographic department of the Sellers Iron Works, of Philadelphia (where an immense deal of work is done in photographing models, drawings, castings, plans, &c., &c., connected with his business), with great success. This photographic department is of great advertising value to his Works, as he sends (in lieu of a long reply to inquirers about any machinery) one or two stereoscopic pictures of different sides of the machine, and the thing is seen and understood at once, and these pictures are seen and criticised by dozens, while a description would only be read by the person to whom addressed. The only talk here for a month past has been "Fumination," which has been harped upon, quarrelled over, and peddled out for three dollars. The experiences of Anthony's Fuming Process are curious. Spirit Photography is having a run also. This humbug is certainly well managed, and it is surprising that the Boston Yankees even can gull so many men of fair knowledge. The *Banner of Light* (Spiritualist paper) suggest that a Committee be appointed from photographers and from believers, one half of each, and they do go into a full investigation of the process. If this is done we can know something about it. One fact somewhat curious is the depreciation of prices of photographic work here, while all materials have appreciated. Gold and silver have almost doubled in value on account of the depreciation of our currency, while the finished pictures bring but half the price of two years ago. Cartes de visites are advertised at \$1.50 per dozen, at present rates of exchange about 3s. 8d. sterling, and yet the rush of business never was so great. To have a negative taken now requires the filing of your name and appointing an hour several days ahead, and then, necessarily, you must take the first result of the sitting. In another week a dozen pictures are sent to your house, and you pay for them whether they resemble you or Tom Jones. Great business country.

Our *rear* this side of the Atlantic has got to be a national institution, and as such will probably be kept running for some time to come. We do everything here on a big scale. We can get up the biggest ghost stories, the biggest accidents, the biggest factories, the biggest men, and we have shown how we can get up the biggest rebellion, and the biggest guns and armies in the world, and bye-and-bye we'll show how we can get up the biggest peace on record.—Yours respectfully,

F. F. THOMPSON.

New York, March 5th, 1863.

IS ALBUMEN RENDERED INSOLUBLE BY THE SALTS OF SILVER?

DEAR SIR,—I think the following few experiments (from many others) undertaken in connection with my manufacture of albumenized paper, go far to prove that NO₃ bears a most important part in rendering albumen insoluble, as expressed by me at the late discussion on the paper of G. Price, Esq., read at the South London Photographic Society, last meeting.

As an introduction to the experiments, I will put the question, why is it really necessary the albumen should be rendered insoluble in sensitizing? To enable it to resist the action of *after chemicals* it has to be subjected to.

1st. Precipitate AgO, NO₃ by NaO, A+6aq; wash the crystals, or add them without washing, to a portion of albumen, we have then a *salt of silver* in combination with albumen and its allied elements and natural salts. Treat

these mixed precipitates with our ordinary fixing solution (NaO, S₂O₂) and they will be entirely dissolved.

2nd. Add a few drops of paper bath solution (equal to quantity taken for precipitation in first experiment) to corresponding amount of albumen. Here we have the appearance of real coagulation; not a mere precipitate diffused in a viscous medium as in first experiment. Now treat these precipitates with NaO, S₂O₂ when the silver salts alone will be dissolved leaving insoluble films of albumen, with traces of silver.

3rd. Take another portion of albumen and precipitate with NO₂. Here the coagulation resembles that produced in Exp. 2nd; carefully neutralize with KO, and treat with NaO, S₂O₂ the precipitate remains undissolved in our usual fixing agent as in Exp. 2nd.

In conclusion I have only to add that it will easily be seen by photographers having a slight knowledge of chemical operations, why the best results are produced by a strong silver bath for albumenizing paper. I should feel much obliged if some of your correspondents will try the above experiments, and report thereon in PHOTOGRAPHIC NEWS; not being aware of similar ones ever having been published, which, of course, is the only test of priority.—I remain, dear Sir, yours obediently,

FREDERIC W. HART.

52, Canterbury Road, Islington, N.

Photographic Notes and Queries.

COLOURED GLASS FOR DARK ROOMS.

SIR,—Allow us to correct some erroneous impressions as to the non-actinic glass for dark rooms. It is frequently called "silver-flashed glass;" the glass is, however, stained, not flashed; the difference being that in flashed glass the colour is blown, or flashed on by gathering on the blow pipe, first, some ordinary metal, and then some of the colour required; whilst stained glass is produced by floating over a sheet of ordinary glass the required preparation, and burning it in the kiln.

In a recent number you recommend, in your answer to "Excelsior," the glass with a mottled or stippled effect. This, however, is not a test, as it occurs in glass which will admit the actinic rays, and is in fact a defect in laying or burning in the stain, and also in its non-actinic properties, as will be seen by testing a piece over sensitive paper, when the mottled effect will be found to be reproduced on the paper, proving that the actinic rays pass more readily in some parts than others.

We have found by experience that the property of excluding the actinic rays does not depend alone upon the colour being produced by silver, but that it is necessary to test the glass, a plan which we now always adopt before selling it for that purpose.—We remain, sir, your obedient servants,

CLAUDET AND HOUGHTON.

[We recommend the glass with a mottled appearance, not because the mottling possesses any advantage, but because it is one of the indications of the silver stain, which we have always found non-actinic, and the mottling is the only visible guide to the eye, indicating the proper quality; and although it may originate in a technical defect, it is always more or less present in the glass stained with silver. When the stain is thin and the mottling very distinctly marked actinic light will be admitted as we have frequently pointed out. We have also sometimes examined glass not stained by silver, pot-metal, which is quite non-actinic, but it is rarely met with. Silver colouring is generally the most trustworthy. The technical difference between staining and flashing is unimportant to the photographer.—Ed.]

REVOLVING GLASS ROOM.

DEAR SIR,—I beg to thank you for the advice received some time since, respecting the photographic house I was then about building. I have just finished it, and think it is everything that can be desired or wished for; the following are the dimensions of it:—

Length	26 feet 6 inches.
Width	10 "
Height to eaves	8 "
Side lights	8 " by 5 feet.
Top	10 " by 10 "

The house is erected on 4 wood pillars 8 feet high, with a cross and curb on the top, and fitted with iron rollers acting on the top of the curb, and, by a simply contrived lever, it may be easily turned round by the persons inside to face any quarter that may be most desirable, and to get the best light on the sitter. Should any of your readers think of building a photographic house, I think they would not regret the trifling extra outlay, of having it made to turn round.—I remain, sir, your obedient servant.

CHARLES SCARFE.

Alford, March 9th, 1863.

THE SACCHARO-SULPHATE OF IRON versus "THE DOUBLE SULPHATE OF IRON AND AMMONIA."

SIR,—As a new developing agent has been recently introduced by one of the leading photographic firms, and is, therefore, likely to be extensively tried. I beg to call attention to the suggestion of an amateur made some two or three years ago, I believe in these pages, of the use of another double salt of iron as a developer. This is the saccharo-sulphate of iron. Upon reading the communication referred to, I at once procured some of the salt, and found that its properties, and the results produced by it as a developing agent, fully bore out the description given. It has no tendency to peroxidize, and the crystals retain their beautiful greenish-blue colour, when kept in a corked bottle apparently indefinitely. In solution it yields extremely clean and dense negatives, and the positives obtained by it are of a very pleasing tone. I should not have troubled you with this note had I not considered the saccharo-sulphate were worthy of attention in these days of "iron development," and a salt which I feel persuaded has never received, at the hands of photographers, a fair trial.—I am, sir, yours, very faithfully,

CYMBRO.

SPOTS ON DRY PLATES.

DEAR SIR,—In the News of the 6th inst., page 112, I see an extract from the *American Journal*, in which the author records having met with round insensitive spots on tannin plates, which had been first coated with albumen. I have very frequently met with similar spots in collodio-albumen plates (I adopt the plan of coating the plate with gallic acid before drying); can they have anything to do with the albumen?

Having very little time to devote to photography, I have not been able to trace the origin of these spots, but have noticed that when the plate was wetted, they have whitened more readily than the rest of the film, from which fact, I fancy that they arise from some hygroscopic substance, which attracts moisture from the air. Out of a batch of eleven plates lately exposed, and prepared at two different times (some being six months old), only one presented them. I have not noticed that they are worse from the development being delayed after exposure, but I never remember to have met with them on freshly prepared plates. Should you think this worth inserting in your next issue, pray make what use of it you please.—I am, dear sir, yours faithfully,

J. A. C. BRANFILL.

10, Bridge Street, Westminster,
March 16th, 1863.

[Perhaps some of our readers can throw some light upon this trouble, which must have occurred more or less in the experience of all dry photographers.—Ed.]

Photographs Registered during the Past Week.

- MR. JOHN STUART, Glasgow,
Two Photographs of Mademoiselle Vaneri.
- " " " of Miss Kirk.
- MESRS. ROBERT HILLS AND JOHN HENRY SAUNDERS, Oxford and Elton,
Photograph of "The Oxford University Crew, 1863."
- " " " of Bishop Tozer.
- " " " of Canon Stanley.
- MESRS. LLOYD AND JEFFERSON, Southampton, Lancashire,
Photograph of Rev. W. Landels.
- MESRS. BECKETT AND WILLIS, Scarborough.
Three Photographs of Elihu Burritt.

* * Photographers wishing the Publisher to register for them must fill up one of the printed forms themselves. The form can be had of the Publisher by remitting two stamps. Two or more pictures can be entered on one form, but each must be separately described.

The fee for each picture is 1s. 3d.

Talk in the Studio.

PHOTOZINCOGRAPHY.—In the report of the Topographical Department, with reference to photozincography, Sir H. James states that photozincographs are now produced by him from nature, and any number of copies can be taken that may be required; the beauty, extreme simplicity, and cheapness of this process, he adds, are certain to cause it to be very generally adopted for producing illustrations to works on all kinds of subjects.

THE FIRST PHOTOGRAPHS OF THE PRINCESS OF WALES.—We have pleasure in stating that our valued friend and contributor Mr. F. R. Window, had the honour, a few days ago, to take the first portrait of Her Royal Highness the Princess Alexandra since her marriage. His Royal Highness the Prince of Wales, and their Royal Highnesses Prince and Princess Christian, the Princesses Dagmar and Thyra, and the Princes Frederiek and Vladimir also sat to Mr. Window, who secured some of the most pleasing portraits that have been issued of the Royal sitters.

RAPID TANNIN PLATES WITH A BROMIDE ONLY.—Major Russell, in a recent letter we have received, says:—I have lately found some important improvements in preparing dry plates. In investigating the method recommended by Mr. Keene, but using tannin alone, I find that a considerable increase of sensitiveness is obtained by washing off the tannin before drying, but that no difference is made by leaving nitrate of silver in the film before applying the tannin, except that a liability to stains is thus incurred. I also find that bromide alone in the collodion is twice as sensitive as 3 parts bromide to 1 part iodide, which mixture is more sensitive than any containing less bromide. The bromide requires different treatment throughout to that required by iodide; and the best way of working has not yet been determined in some points, but it seems to produce a better quality of negative for landscape views, and to work with greater certainty than iodide; the carbonate of ammonia developer works better than acid, silver, and pyro, with bromized collodion. By both the improvements which I have mentioned, not less than three times as great sensitiveness is gained, I think, besides the advantage given by the ammoniacal developer.

VIGNETTED BACKGROUNDS.—Mr. A. H. Wall informs us that he is now preparing a class of pictorial backgrounds, which he anticipates will be useful to many photographers. They consist of vignetted landscapes in which the formal ugliness of the oval, often given by the common vignetting glass, is avoided, and the time saved which is necessary to secure good results, by other methods. The sole care with these backgrounds will be to get the figure into the right position in relation to the landscape, and in printing to cut off the figure also in proper relation. A vignetted print with a suitable pictorial background, is often very pretty.

To Correspondents.

CORNISH CHROM.—The chief causes of the flatness in prints No. 1 and 2, are, in the first place, over-intensifying in the negative, and, next, under-printing. The coarseness and granular texture in No. 3 are partly due to a coarse film, a little over-intensifying, and partly to meanness in toning.

PERPLEXITY.—The difference in weight between a given measure of distilled water and the same measure of bath solution will of course represent the amount of nitrate of silver present, a slight allowance being necessary, however, for the water displaced, or increase of bulk produced by the nitrate of silver; but it is a somewhat roundabout method of getting at the strength of the solution. If you cannot afford a silver meter, and cannot satisfy yourself by means of precipitation by chloride of sodium, you may, by a little ingenuity, manufacture a meter with a test tube and a little mercury.

BICHLORINE.—There is much discrepancy of experience in regard to the darkening of negatives intensified with bichloride of mercury and iodide. We have some negatives so intensified, which have darkened after long printing, and some which are not changed by the same treatment. Some of our correspondents tell us that they invariably meet with this result, whilst others do not meet with it. We can only recommend you, if you find that such a result occurs in your hands, to adopt another method of intensifying. In some cases submitting the negative which has blackened to considerable heat restores its softness again. You can try if it answers with your negatives.

G. R. G.—We have never found the silver solution run in greasy streaks on the paper; but your suggestion of the presence of ether may explain it. The surface of the paper being in any degree greasy might also account for it, and with a horny, repellant surface, too short floating might account for it. To determine certainly the cause or remedy a few experiments with the materials used would be necessary.

PHOTO. Oxford.—The best apparatus for enlarging photographs to the size of life, of which we have any knowledge, is the solar camera, upon which many articles have appeared in our pages.

SUBSCRIBER T.—Citric acid will not decompose nitrate of silver if free nitric acid be present. The solution should be neutral or slightly alkaline. When you added citric acid and saw no change produced, and then found a white, curdy precipitate on adding a little ammonia, it was citrate of silver which was thrown down. 2. For toning it is better to work to a definite formula than to use the mixture you describe, the exact constitution of which it is impossible to determine. When the toning solution begins to turn reddish or purple it is an indication of decomposition, the colour being caused by finely divided metallic gold. 3. The whites of your prints "not being clear" arises from the fact that the negatives are thin, and that there is a little over-printing. 4. The stain on your vignette arises from the print having been touched with hypo before fixing; probably your fingers had come into contact with hypo and then touched the print in toning. 5. Your tones are good; but the portraits are over-printed. 6. The figure is lighted too much from the front; the negative is over-intensified; and the print is over-toned.

J. C. S.—Scratches can be polished out of lenses; but you will run a great risk of altering the figure and spoiling your lens if you attempt it yourself. 2. In good lenses each lens of the combination is burnished into its cell so that it cannot be placed in a wrong position. In cleaning others, if you are not familiar with their construction, the best plan is to replace each lens in its position before taking out the next; and it is not wise to often take your lens apart; as the interior surfaces of the lenses once properly cleaned ought not to need the operation very frequently, not being exposed. In the ordinary portrait combination the front meniscus lens has its convex side outwards; the back combination has the double convex lens outwards, and the concave lens with its concave surface towards the double convex lens.

SUBSCRIBER.—The toning process used by Mr. Lacy is to be used as we gave it, the only addition to the gold is the chloride of lime, which has a strongly alkaline reaction.

J. BUTLER.—In order to obtain a pyroxyline giving greater intensity, add a little water to the acids, or elevate the temperature, or both. The weaker the acids, and the higher the temperature up to a certain point, the more intense the collodion made with the cotton. The cotton will, also, be more soluble, and the larger the amount of cotton you can use, other things being equal, the more intense the collodion.

AN AMATEUR.—The operations you describe are of a very slipshod and unsatisfactory character; but we fear that in many commercial photographic establishments matters are managed somewhat loosely. We can only recommend you, however, to look upon such arrangements as "things to be avoided," no matter by whom they may be adopted.

A.—The addition of iron-developing solution to a silver bath will cause a reduction of a portion of the silver. If a small quantity only have been added, give the bath a dose of carbonate of soda and sun it, when in all probability it will, after filtering out the precipitate, work out all right.

J. F. TRELL.—The cards received have many very excellent qualities; the arrangement is artistic and pleasing, and the photography is brilliant and pure; the pictures altogether displaying good taste and careful manipulation.

MR. ENGLAND'S APPRENTICE.—We answer you under this name rather than your own, which you sign, out of consideration. We cannot enter further into a discussion of private or personal matters in our pages. Let us urge upon you, as an apprentice, diligence and a conciliating, or even submissive, demeanour to your employers, and you will meet with consideration in return. Depend upon it that it is a bad beginning in life for a youth to stand upon his real or fancied rights as to the amount of labour he will perform.

J. BURGESS.—We have not met with any such experience in using resinized paper. We will submit the specimens to Mr. Cooper and ask for his opinion. The examples of your early experience with it are very good indeed.

WILLIAM GREEN.—The spots in your print are similar to several which have been submitted to us recently. We can only conclude that it arises from some cause in the paper, since we know of no other cause. The effect is similar to that produced by the contact of acid with the print before the hypo has been washed out. The general photographic qualities of the print are good.

A DORSET AMATEUR.—The multitude of small black spots in the print doubtless arise from pin-holes in the negative, and these may arise from various causes; very probably in this instance from the supersaturation of the nitrate bath with iodo-nitrate of silver. See several articles on the subject which have appeared in our pages recently.

LECIA.—We cannot tell you exactly how to bromo-iodize your stock of plain collodion without knowing something of its constitution. Some samples are sent out requiring the addition of one ounce of iodizing solution to three of collodion; some one ounce to seven of collodion. Try, however, as follows: dissolve in one ounce of alcohol 24 grains of iodide of cadmium, 12 grains of iodide of ammonium, and 8 grains of bromide of cadmium, and add this solution to 7 ounces of the plain collodion. Should this prove too thick, then add a little more alcohol to reduce it to a working condition. 2. The opaque part of the roof overhead may be painted white or grey.

O. K. WALKER.—Your prints are not by any means the worst that reach us for examination; but there is still room for improvement. No. 1 is not quite sharp and a little over-intensified; No. 2 is better, but the light on the face is a little too evenly diffused, and the face lacks contrast a little; No. 3 the same characteristics, and a little over-intensified; No. 4 the same; No. 5 is soft and round, but lacks force a little. With continued care and perseverance you will soon attain excellence.

W. CALLOWAY.—Thank you for the address; it shall be forwarded to the right quarter. Regarding the paper to which you refer, we have not yet expressed any personal opinion of the practical result, but only of the principle. So far as we know it has not yet been produced quite to the satisfaction of the manufacturer.

OXALIC ACID.—We will take an early opportunity of examining the material received, and, if we can, help you in the matter.

Several Correspondents in our next.

* * * Advertisers are respectfully informed, that the PHOTOGRAPHIC NEWS will be published a day earlier next week, on account of GOOD FRIDAY.

* * * Several Advertisements left over for want of space.

THE PHOTOGRAPHIC NEWS.



Vol. VII. No. 239.—April 2, 1863.

CONTENTS.

	PAGE		PAGE
Amateur Portraiture	157	A Short Lesson in Photography.—No. 11	164
Mr. Rejlander's Studio	158	Proceedings of Societies	165
Fuming Sensitive Paper with Ammonia. By George S. Penny	158	Imperfections in Albumen Prints	166
On Developing the Photographic Negative. By M. Aug. Testelin	159	The International Exhibition.—Report of the Jury	166
Strengthening Negatives. By C. Ommeganck	160	Photographic Notes and Queries	167
The Accelerating Effects of Bromides in Collodion. By Charles Waldack	160	Miscellaneous	167
Thallium	161	Talk in the Studio	168
A Short Lesson in Chemistry.—No 7.	162	To Correspondents	168
Development by the Fumes of Ammonia. By Alfred Verity ...	163	Photographs Registered during the past Week	168

AMATEUR PORTRAITURE.

THERE is no branch of the photographic art more fascinating than portraiture; and whilst excellence is generally supposed to belong only to the professional photographer, who is properly equipped with glass-house and proper accessories, there are few amateurs who have not made some attempts to depict the "human face divine," beginning by victimizing their friends as sitters, and ending by being victimized themselves in the demands for prints from some especially fortunate negative.

The much neglected glass positive was at one time most in favour amongst amateurs, but it now seems almost entirely discarded or forgotten, a circumstance much to be regretted, as some of these positives, when really good, were very beautiful. The fine white positive produced with the proto-nitrate developer, having a texture like matt silver, has rarely been surpassed by any class of photographs. The good alabastrine positive, either plain or skilfully tinted, possessed qualities we have not often seen equalled. But all these, as well as the common flat tawny positive, which was no credit to photography and could claim nothing of art, seem to have had their day, and may possibly, ere long, be named with daguerrotypes, as belonging to the extinct arts. Paper prints, especially card portraits, at present seem to claim almost sole attention from professional and amateur photographers.

Amongst amateurs a very general impression prevails that a glass house is necessary to portraiture. There can be no doubt that entire control over the lighting of the sitter is of great importance in securing the best results, and that to the professional portraitist it is imperative. There are, nevertheless, a number of effects possible to the amateur which are often pleasing and well worthy of a little attention. If other evidence or experience were wanting, the pictures contributed by Lady Hawarden to the recent Photographic Exhibition, furnished ample illustration of what might be done without the facilities of the professional portraitist. The majority of the pictures exhibited were taken in the drawing-room of her ladyship's residence; many of the figures being brought close up to the window, a portion of which, with the balcony, foliage, &c., beyond, were included in the picture. These, whilst satisfactory as pictures and artistic studies, independent of any likeness they might possess, were, we understand, not less valuable as portraits. The absence of the backgrounds and other accessories of the professional studio, we should regard in many instances as a positive advantage, as we have no wish to see amateurs competing with professional men in producing the conventional photographic portrait, however perfectly it might be achieved.

As a general rule the amateur is confined to the use of an ordinary room or the open air, and in both cases, by a little care and judgment, satisfactory lighting may frequently be obtained. To begin with the light in an ordinary sitting room with one window, with which we have seen very fine

effects produced, especially where the window was lofty. The sitter should, as a general rule, not be placed exactly opposite the window but a little behind it; a folding screen, or a clothes horse, covered with a white sheet, and placed parallel with the window may be made to throw a very good reflected light on the shadowed side of the face and figure. The nearer the sitter is placed to the window the more violent the contrasts of light and shadow will be; the further removed from the window the less violent the contrasts, but the longer the sitting necessary. On a bright day, and when the apartment is well lighted, the sitter may be placed at the side of the room opposite to the window. In some winter experiments we found that an exposure of thirty seconds was sufficient for a negative of a sitter placed twelve feet from a window, not much exceeding seven feet by four feet, using Dallmeyer's No. 1 B lens with open aperture. By a little management the actual furniture of a room may frequently be made to answer for the background. Care must be used, however, to avoid cutting up the picture by a number of spotty lights, and also to avoid having objects so much out of focus that their forms are not even indicated. A golden rule for portraiture in an ordinary apartment is to use a freely bromized collodion, which will not only give the maximum of sensitiveness, but will also check the tendency to undue contrasts which generally exists where the light reaches the sitter from one small source. As a further means of counteracting the tendency to black shadows, a full exposure should be given, and a strong iron developer used.

In open air portraiture as a rule an opposite tendency to that in an ordinary sitting room prevails. In the latter, as we have said, the tendency to undue contrast is common; in the former to want of contrast and consequent flatness. A collodion with a moderate amount of bromide is most useful here, and the presence of a little free iodine will be an advantage. Where it is convenient the sheltered angle of a wall or building should be sought so as to secure some shadow on one side of the face. With an equal light all around it is almost impossible to secure roundness or relief. If there be an open expanse of sky immediately behind the sitter it will be almost impossible to prevent fog from the mass of diffused light entering the lens. In all attempts at portraiture in the open air it is desirable to have the lens well protected from diffused light, the use of a cone of paste-board, blackened inside, which we have often recommended, will be found very useful. Where it is possible, a screen or awning should be placed above the head of the sitter to prevent the undue action of top light, of which there is, of course, a very large proportion. As regards background, a portion of a building, a portico, an arbour or rustic seat, a few shrubs or trees, or a combination of parts of several of these may often be made to give an excellent effect; and as in open air portraiture the exposure is often very short, a sufficiently small stop to give moderately good definition to the background objects, may without disadvantage be used. Where the amateur may prefer it a plain background may

easily be improvised: a blanket or a grey shawl hung across a suspended cord readily furnishes one. Or, where a vignette portrait is desired a less extensive background than this may be; for, as very little of the background will be seen in the vignetted picture, a large sheet of brown paper alone is sufficient to furnish a very excellent background.

An exceedingly good effect may sometimes be obtained by placing the sitter just within a doorway or an open French window, one half of the figure being in the full light, and the other in the shadow of the room. By a little care in arranging the position so as to avoid too much shadow, the effect here produced is very charming, the more so if a little foliage, &c., be seen beyond. In the case to which we are alluding, the camera is of course in the room, so that the shadowed side of the face is presented to the camera; and it is scarcely necessary to say that unless the shadow is kept very transparent and tender, a heavy inartistic effect must result. This, however, with sufficient exposure, and freely bromized collodion, may easily be secured: an exposure of about twenty seconds with the lens before referred to, giving an excellent result.

We have not here entered into the general question of portraiture, in reference to posing, expression, and general accessory, our sole object having been to throw out one or two suggestions in reference to methods of lighting not usually considered available for portraiture, for the benefit of amateurs not much experienced in this branch of photography.

MR. REJLANDER'S STUDIO.

MR. REJLANDER informs us that our misgivings as to the amount of light in his glass room have proved groundless in practice; it answers admirably. It has, moreover, rather less light than we stated. The door *a* in our diagram, which was not hung when we first saw the studio, and which we understood had to be glass, is simply of wood. We give some extracts from a letter in which Mr. Rejlander refers to some minor modifications which would be an advantage:—

"In juxtaposition to the cut of my studio you place an old cut (?) by Mr. Sutton, which looks very much like it, but I had never seen it before; if I had I should have adopted mine to his, not because of the length—which I find I shall have to do—but the slope, which is much better, and I should so far improve upon it as to slope *c,d*, as well, so as to get the glass more at an angle to the sitters.

"When I can afford it I shall make another alteration, instead of straight lines for the background and the side opposite the light, I shall have them both curved, perhaps a catenary curve.

"As to light, I have abundance without overflowing, but 'just the ticket.' As to ventilation, the undulated edges of the corrugated iron secure openings all around the house, beside the door and one opposite the sitter that you did not notice.—Yours truly, and always in a hurry when letter-writing,
O. G. REJLANDER.

P.S.—I took a group of twelve last Wednesday—plenty of light for all."

FUMING SENSITIVE PAPER WITH AMMONIA.

BY GEO. S. PENNY.

HAVING read the report of the discussion at the last meeting of the Photographic Society, following some remarks made by Mr. Debenham upon fuming sensitized albumenized paper, to say nothing of the remarks being illiberal, the conclusions are to my mind so illogical, that I cannot refrain from the attempt to prove the fallacy, not of Mr. Debenham's experiments, but of the argument he deduces from them.

It is a pity Mr. Debenham should have rejected the compliment offered to him for having proclaimed his failure, and claimed a success, because this can only be granted to him taking the word in the "Pickwickian sense." In the ordinary acceptation of the words, success and failure,

supposing the author of these remarks to have undertaken his experiments with the view of succeeding, surely he failed; if he entered upon them with the idea of failing, then he failed; or if he insists that success is the right word, why, he succeeded, but only in proving that *he failed*, not, as he asserted, in "clearing away a fallacy."

If every new discovery yielding contradictory results in different hands is to be shelved, or rather buried, in so unceremonious a way, it offers a serious bar to progress. Whatever the present value of this process, as it seems to involve a principle at present not understood, which may some day tend to important results, our aim ought to be to discover the *rationale* of its action, not to attempt to disprove facts.

Thinking that the question, as Mr. Malone remarked, might be one of manipulation, I have conducted a few more experiments with a view of determining how far that is the case, and also of verifying my original experiments, the result of which I sent you on a former occasion.

I now enclose some prints illustrating two series of experiments. For the first series I sensitized a piece of Collins' albumenized Saxe positive paper, on a 60-grain nitrate bath, acidified with nitric acid. The particulars are seen in the table below.

No. 1.—Not fumed.	Exposed 28 minutes.
2.—Fumed 3 minutes.	" 21 "
3. " 7 "	" 15 "
4. " 10 "	" 20 "
5. " 15 "	" 20 "

For the following series a piece of the same paper was sensitized upon the same bath reduced to 30 grains to the ounce.

A 1.—Not fumed.	Exposed 49 minutes.
A 2. " "	" 63 "
B 1.—Fumed 4 minutes.	" 49 "
B 2. " 15 "	" 23 "
B 3. " 30 "	" 24 "

The first series were exposed consecutively in full sunshine. The second were exposed in the shade, A 1 and B 1 simultaneous to the two halves of the same negative, for the purpose of demonstrating, by contrast of intensity, the superior sensitiveness of the fumed over the unfumed prints.

In the other specimens I aimed at printing all to the same intensity, that the effect of fuming may be judged of by a comparison of the relative times of exposure. On removal from the pressure frame I find the fumed prints not warmer than the unfumed, as Mr. Debenham finds them, but of a rich violet or purple, as if richly gold-toned. The prints of each series were toned all together, for the same time, in an acetate bath, and remained all the same time in the hyposulphite.

I think it necessary to state my own conclusion from these experiments, as the majority of your readers will not have the opportunity of seeing the prints. In the first series No. 1 is somewhat less intense, and rather less toned than the others, which are all as near as possible the same tone and strength; showing, much to my surprise, that a long or a short fuming makes not much difference either as to sensitiveness or other effect. In the second series with the weaker bath, the difference in sensitiveness appears still more in favour of the fumed.

The difference in time between A 1 and A 2, is accounted for by the fact that the latter was printed later in the day when the light was not so good. B 1 exposed with A 1, shows a much greater depth of printing than its fellow, as indicated by the bronzed shadows. The remaining two are very much alike in strength and colour. It is a question how far the particular salt in the paper, and the proportion of it, affects the result; this might soon be decided if the albumenizers would kindly furnish the required information.

I should feel obliged if you would, after examining the prints, state your conclusions whether they agree with or differ from mine, and if you think the experiments worth bringing before the notice of either of the societies you are quite at liberty to do so.

It is not worth while to refer to the originality of my experiments upon this subject, further than to thank the Editor of this journal for correcting the misstatement that I had been carrying out the American discovery, and thus fulfilling one of the highest offices of a journalist, viz., that of vindicating the truth, whether the matter be one of great or of small importance.

Cheltenham, March 28th, 1863.

[The specimens we have receive strikingly bear our Mr. Penny's remarks; those which have been fumed being in all cases deeper in tone, as well as having been printed in a shorter time. We shall take an opportunity of bringing them before some of the societies, and probably at the same time some experiments of our own in the same direction.—Ed.]

ON DEVELOPING THE PHOTOGRAPHIC NEGATIVE.

BY M. AUG. TESTELIN.

The photographic image is not visible upon the sensitized plate immediately after its exposure in the camera; we know that to cause it to appear, it must be submitted to particular reactions, which gradually develop it with all the requisite details.

In the collodion process we produce these reactions by means of special reducing solutions, the particular composition of which is one of the distinctive characteristics of the process.

The reducing agents most employed for developing collodion images are, sulphate of iron and pyrogallie acid, either separately or when the sulphate solution only has been employed, to make the image appear in feeble strength with a view of being afterwards strengthened by pyrogallie acid, in order to keep the picture very pure and give it more relief and brilliancy.

The sulphate of iron developing solution must be employed only in a weak state. When too strong, the development proceeds so rapidly that time is not given to watch the appearance of the image, which appears suddenly, and is immediately fogged, even before we are able to stop the reaction at the proper moment, a crisis which we can appreciate only by an attentive inspection of every part of the proof.

Employed as a dilute solution, with a certain quantity of acetic acid added, the sulphate of iron produces a gradual and less energetic development; the image appears successively in every part, clear and well defined, its contours well detached, and we can produce at pleasure more contrast or more harmony between the whites and blacks.

This mode of development has the indisputable advantage of permitting the employment of collodions reddened by iodine, and of acid sensitizing baths, the use of which is infinitely preferable. The exposure in the camera is shorter than required with pyrogallie acid, and in all cases the negatives thus produced are much superior in transparency, by the complete detail which we can obtain both in the most opaque parts, and in the lightest, and by the softness, delicacy, depth of the shadows, and the admirably modelled condition of the luminous portions.

But to obtain all these qualities, we must not seek to obtain a picture at first as intense in the opaque portions, as it is desired they should remain: for in that case we produce only hard negatives, completely black in the shadows, and without detail in the whites, an effect frequently attributed solely to the too energetic action of the sulphate of iron, while it is principally due to the too great concentration of the sensitizing baths, which, by leaving abundance of nitrate of silver upon the film, furnishes immediately so great a quantity of particles of reduced silver, which are carried in a mass to the most impressed portions of the film, where they form considerable deposits.

On the contrary, it is with very weak acid intensifying baths that the image successively appears in every part, and

if it then lacks the necessary intensity for printing positives upon paper, we can easily communicate it by a well conducted intensifying.

Returning to the preparation of the sulphate of iron developing solution, we give the proportions in which it is employed; and which are nearly the same as those employed by operators working by methods analogous to our own.

Sulphate of iron	50 grammes
Crystallizable acetic acid	...	30 to 40	"
Water	1000 "

We sometimes add to this solution alcohol in the proportion of 4 to 5 per cent. of the ferric solution. The object of this addition is to give to the developing solution about the same density as that of the argentiferous liquid covering the sensitive plate, which is saturated with the ether and alcohol of the collodion, and forms a sort of greasy film, which prevents the equal mixture of the two solutions, producing marbled spots upon the negative, due to the liquid veins of different densities, which cause a partial reduction.

In our own practice we suppress the addition of alcohol because the acetic acid suffices, acting as a moderator of the reducing action, communicating at the same time to the solution that penetrating property which facilitates the perfect mixture of the liquids.

With the solution thus composed, the image is not suddenly developed, it is only two or three seconds after its extension upon the exposed film that the parts most vividly lighted begin to appear, and the whole is developed in from 30 to 50 seconds. For we particularly recommend the stopping of the action of the sulphate of iron as soon as all the details have come out sufficiently, without considering if the negative be vigorous enough for printing with, as it is much more advantageous to give the requisite intensity to it by the intensifying processes hereafter indicated.

Until recently pyrogallie acid was almost exclusively employed for developing collodion negatives, and it is still one of the best reducing agents for that purpose: but now the employment of sulphate of iron has become so general, on account of the facility with which it is managed, and of the regularity and promptitude of its results, that pyrogallie acid serves only, it may be said, to complete the development begun with sulphate of iron.

Still pyrogallie acid is often necessary to give to certain subjects more contrast than they naturally exhibit, and where the sulphate of iron does not sometimes act so advantageously. It is on account of this property that it is preferred for the images of all objects in which the tints are black and white rather than coloured.

Under the action of this reagent the image appears almost as rapidly as with sulphate of iron, but is infinitely longer in finishing, and requires a more prolonged exposure to the light for the details to come out sufficiently.

The solution of pyrogallie acid is particularly suited to the development of images formed upon a sensitive film prepared with neutral products; it is composed in the following proportions:—

Water	500 cubic centimetres.
Pyrogallie acid	1.30 grammes.
Acetic acid	30 cubic centimetres.

When we are compelled to prolong too much the contact of the pyrogallie acid upon the collodion film, the latter at length detaches itself from the glass, causing the loss of the image, or at least a portion of the negative. This result is due to the large quantity of acetic acid the solution contains, and may be avoided by substituting citric acid for acetic acid, which also presents many advantages with regard to the negatives themselves, which are very pure and possess great transparency, only the citric acid does not communicate to the bath that greasy property which facilitates the uniform extension of the liquid upon the plate; it therefore becomes necessary, to this end, to introduce a certain quantity of alcohol. The solution is then composed as follows:—

Water	500 cubic centimetres.
Alcohol	45 do. do.
Pyrogallic acid	1·30 grammes.
Citric acid	1·50 do.

This solution becomes decomposed in the course of a few weeks, it absorbs oxygen and deposits a very light brown substance; it first assumes a light brown tint, which becomes deeper and deeper. Then, at the time of pouring it on the plate, it almost immediately precipitates the silver of the sensitizing solution adhering to the sensitized plate, and the development of the image is checked, because the molecules of reduced silver instantly group together, forming corpuscles of too large a volume for them to continue to follow the attractive force that draws them to the parts modified by the light to which they can no longer attach themselves.

(To be continued.)

STRENGTHENING NEGATIVES.

BY C. OMEGANCK.

To obtain negatives of suitable strength we must employ a developer which does not give at once all the opacity required; for if we employ an iron solution adapted to produce a finished negative at once, we incur on the one hand the risk of too strong a negative, which will give positives on paper in which the lights of the picture cannot be distinguished from the first shades. It also presents another inconvenience; when the negative produced under the conditions of a vigorous development is a little too feeble, it then becomes very difficult to strengthen it, without exceeding the proper intensity. And, lastly, in a negative feebly developed, the details of the dark portions come much better than with very strong development.

We can strengthen either before or after the fixing, or at both these periods at the same time, if necessary. The strengthening after fixing can be made by daylight, and is more easily performed, because we can better watch the gradual strengthening of the picture from the first up to the point at which it is desired to stop it, the tone afterwards remains nearly the same, a simple washing merely suffices to finish the negative, while, if we strengthen before fixing, the fixing removes a notable quantity of the opacity we had obtained.

Strengthening by means of pyrogallic acid with the addition of acetic acid and nitrate of silver, according to the ordinary formula, appears to us to merit the preference over all other processes hitherto described. The employment of citric acid, in place of acetic acid, may present certain advantages, especially in dry processes.

Strengthening by means of the salts of mercury is generally discontinued, especially when, to obtain the necessary strength, we must have recourse to sulphurization, either by hyposulphite, or by any other sulphite, for then we obtain negatives which are liable to become weaker and even to disappear altogether.

Besides, to strengthen an extremely weak negative, we whiten it with corrosive sublimate to blacken it afterwards by means of hyposulphite, or of sulphide of ammonium, it thickens so much that the delicate lines become completely obliterated.

An intensifying solution is sold at ten francs the litre which is not worth ten sous, and which, it is declared, does not contain the slightest trace of mercury. Much astonished will the photographer be if he drops a little of the solution on a clean piece of copper, to perceive it covered with globules of the fluid metal; and if he does not wish to suspect the word of the dealer, there remains for him no alternative but to believe that he has realized the alchemist's dream, and succeeded in transmuting metals.

This preparation gives much greater vigour to the picture than corrosive sublimate, without whitening it by prolonged contact. It is merely a solution of bichloride of mercury, or

corrosive sublimate saturated with iodide of mercury. It is prepared by making a saturated aqueous solution of corrosive sublimate, then dissolving a small quantity of iodide of potassium in water, and dropping it cautiously into the solution of bichloride of mercury until a red precipitate remains, which does not disappear by agitation.

Sometimes negatives are so feeble that the pyrogallic solution appears to be powerless to communicate to them the tone necessary to ensure good printing of the positives. It is not only by a too strong luminous influence, but also by a long exposure with a feeble light, that we obtain negatives that refuse to be strengthened.

In these circumstances we have for a long time employed a process which succeeds perfectly, and the negatives thus obtained have not grown weaker. The mode of operating is as follows:—

After developing and fixing, wash and cover the plate with a saturated solution of corrosive sublimate diluted with twice its volume of water, until the surface blackens; pour off the liquid, then wash the plate and cover it with the ordinary pyrogallic developing solution; replace this latter liquid by an identical quantity of fresh, but additionally this time with some drops of an ordinary solution of nitrate of silver; pour it off and on to produce the strengthening required, as in the method usually practiced.

If the first operation does not bring the desired vigour, the negative must be washed and treated anew with the mercurial solution, then with the pyrogallic solution, as before. We can in this way strengthen a negative indefinitely, the sensitive film being constantly regenerated.

The operation must be performed in a feeble light. We can replace the solution of corrosive sublimate by the compound solution (bichloride of mercury saturated with iodide of mercury). It will, however, be as well to reduce it by the addition of thrice its volume of water.—*Bulletin Belge de la Photographie.*

THE ACCELERATING EFFECTS OF BROMIDES IN COLLODION.

BY CHARLES WALDACK.*

I WROTE to you some time ago I had repeated some of my former experiments with iodized and bromo-iodized collodion; what induced me to do so was that the accelerating properties of bromide of silver were denied in several communications to the photographic journals, thus creating some doubts in my mind about the manner in which these experiments had been conducted.

The first in this new series of experiments was made three or four months ago. I made some plain collodion with equal parts of ether and alcohol, and six grains to the ounce of Beynch's alcoholic pyroxyline, an article which, as far as I could ascertain, was quite free of that peculiar organic substance which causes collodion to yield intense negatives. This collodion was rather thick, thicker than it ought to be for ordinary work, but I made it so purposely, in order to obtain a stronger contrast between blacks and whites.

Part of the collodion was iodized with $4\frac{1}{2}$ grains to the ounce of iodide of cadmium, and I added a few drops of tincture of iodine, to give it a slight tinge of yellow.

After it was well settled, I took five small bottles, marked them 0, 1, 2, 3, 4, and put one ounce of it into each.

To No. 1, I added one grain of bromide of cadmium.

To No. 2, I added two grains.

To No. 3, I added three grains.

To No. 4, I added four grains.

* We have pleasure in reproducing from the *American Journal of Photography*, this article by Mr. Waldack, who is a most careful experimentalist and clear writer. Our own convictions as to the advantages of a bromide in collodion, based on repeated exhaustive trials, have been often expressed; and we do not therefore feel bound to controvert every statement to the contrary which may occur in communications appearing in our pages; but we are glad to publish experiments so conclusive and so simply stated.—*Ed. P. N.*

To No. 0, I made no addition.

Two days afterwards these different samples were tried; the light was changeable, but as I tried two samples on one plate this was no objection.

The instrument used was a quarter-size Jamini, with half-inch stop.

The object a photographic view.

The bath was of 40 grains to the ounce, iodized and acidified with one drop of diluted nitric acid.

The developer was the ordinary iron one.

Those marked 0 and 1 were tried together on one plate; then 0 and 2, 0 and 3, 0 and 4, each time giving *about one-half or two-thirds of the proper exposure*, in order to be better able to see the difference. The result was that the bromo-iodized collodion gave each time an image more advanced than the iodized one. In the same time the iodized collodion gave an image with denser whites, the half-tones being very slightly marked. In measure also as the quantity of bromide was increased the image became less contrasted, and the details more marked. Between 0 and 3, the difference seemed to be as if No. 3 had been exposed one-third longer; 0 and 4 being tried together the effect was more striking yet.

These experiments were conducted with every possible care, at one time flowing and dripping one collodion first, at another time flowing and dripping the other.

In developing I poured the solution in the middle of the plate, so that it could not be said that on one side some of the solution was washed away.

As there is an opinion prevailing that bromo-iodized collodion is more sensitive, only when used in connection with an iron developer, I resolved while I was at it, to set this matter to the test also, and made a solution of pyrogallie acid.

I tried 0 and 3 together twice, alternating the flowing, and the same result showed itself so plainly, that I thought more trials useless.

In a pamphlet by T. C. Ponting, called "Photographic Difficulties," I had seen an assertion which I found so singular that I resolved to put it to the test also. Mr. Ponting says that with a bath containing nitric acid $\frac{1}{4}$ drop to the ounce, bromo-iodized collodion is most sensitive, but when the bath is made with acetate of soda and acetic acid, iodized collodion, on the contrary, is the most sensitive.

I made thus a solution of acetate of soda with excess of acetic acid, and added a few drops of it to my silver; that I had enough acetate of silver dissolved to saturate the bath was proved to me by the deposit. The bath was tried without filtering, both with iron and pyrogallie, with the same results as before, plain, unmistakable results, which I have here before me at the moment I am writing.

I did not follow Mr. Ponting's recommendation, *to let the bath stand several days*, but as I am in the habit of making my baths immediately before using them, I found Mr. Ponting's recommendation a little obsolete. However, as I wanted my conscience clear from all blame, I tried the same bath several days after, and the result was a foggy picture, so foggy that only traces of it could be seen, with the bromo-iodized collodion, a clear one with the iodized; of course I could not compare them.

Now, after I got through with all that, somebody to whom I communicated these results, found right off a way to account for them in the fact that collodion Nos. 1, 2, 3, 4, contained respectively 1, 2, 3, and 4 grains of sensitizing more than No. 0. I knew well enough, by experience, that his conclusions were false, that a more or less larger quantity of iodizing within certain limits has no effect on the sensitiveness; but to accommodate him, and every one who might think like him, I took another ounce of iodized collodion and added one grain more iodide, then another one, to which I added $\frac{1}{4}$ ounce plain collodion, and tried them on the same glass, with the result I expected, namely, *no difference between the two*.

A few days ago, the collodion being then over three months old, I repeated some of the experiments in presence

of Dr. Van Monekhoven, and in a bath which he had used; the results were identical with the first ones obtained.

An opinion prevailing to a certain extent is, that with pure chemicals an iodized collodion is more sensitive than a bromo-iodized one. If this is true, I must conclude out of it that I never yet had a chance to experiment with pure chemicals. Admitting this to be the fact, pure chemicals are the exception, impure ones the rule. Conclusion: work with bromide.

I think a great cause of error in experimenting with iodized and bromo-iodized collodion, is the giving too long an exposure. When such is the case, the difference between the two images is not so striking. When the plate is much over-exposed, no difference at all can be seen. I think that in these experiments only one-half or two-thirds of the regular exposure should be given.

Another cause of error in comparing developed plates together results from the use of full apertures or large diaphragms. One or two seconds cannot be so easily fractionated as so many minutes. A difference of one-eighth in a short exposure is equivalent to a proportionate difference in a long one. Now, one-eighth of a second is not appreciated, whereas one-eighth of a minute is eight seconds. If we consider the matter in a theoretical point of view, I must confess that we have not got the best of the argument.

Bromized collodion is undoubtedly less sensitive than the iodized (according to Hardwich, ten times less). How could the bromo-iodized be more rapid than either? To point to the same results in the daguerreotype process would, I think, be an error, for the two layers of iodide and bromide of silver are there superposed, whereas in the collodion process the molecules of iodide and bromide are mixed together in one layer. Without waiting thus for a theory to be found to explain this, I will continue, the same as in the past, to use and recommend bromo-iodized collodion for its superior sensitiveness, in the same time recommend it for its half-tones, and for the results it gives with baths, which with iodized collodion could not be used.

THALLIUM.

WE learn, from a lecture delivered on the 27th, by Mr. Crookes, at the Royal Institution, that, by the aid of the grant recently made to him for the purpose, this new metal is likely to be obtained in tolerable abundance, notwithstanding that a ton of pyrites only contains ten ounces of the metal. We cannot do better here than reproduce an interesting summary, from the *Athenæum*, of Mr. Crookes's paper, read at the Royal Society a few weeks ago:—

"A paper which, at the close, was pronounced by the leading chemists present to be one of the most important contributions to chemical science that has of late appeared. Since his discovery of the metal, Mr. Crookes has been engaged in further researches and experiments into its properties, and the sources from which it is derived. In the latter quest he applied to manufacturers of oil of vitriol for specimens of the pyrites burnt by them in the process, and of the deposit left in their leaden chambers; and we are glad to record the fact that the much-desired specimens were sent to him from nearly thirty manufactories. He tested also the various minerals collected in the International Exhibition, to verify his former opinion that "thallium is a very widely distributed element," and found ample confirmation. Thallium exists not only in iron pyrites, but also in native sulphur, zinc, cadmium, bismuth, mercury, and antimony ores, as well as in their manufactured products. As yet Mr. Crookes has failed to detect the "law" of the distribution of this remarkable element; but he has ascertained that it is confined to no particular country, though by no means uniformly distributed in mineral veins from the same locality. Owing to the delicacy of the test employed—the spectroscope—thallium can be detected, if present, in the proportion of only 1 to 100,000. In his statement of the physical characteristics of thallium, Mr. Crookes

shows that it has a distinct colour of its own—has no perceptible taste when bright, but is pungent and biting after long exposure to the air—that it is the softest of known metals, and marks paper as easily as lead, with a streak which changes from blue to yellow—can be compressed in a mold or die, and formed into wire by pressure—that it volatilizes easily, and is a pretty good conductor of heat and electricity—that it is strongly diamagnetic, and readily alloys with other metals. These are but a few of the principal facts brought out during the reading of the paper, which elicited approval, as much for the variety and ingenuity of the experiments by which they had been demonstrated, as for the clearness with which they were described. The paper is to be regarded as an instalment of a subject which has yet to be worked out by laborious research. It cannot be in better hands than those of Mr. Crookes; and, considering the attempts that have been made on the other side of the Channel to deprive him of the merit of his discovery, we notice, with pleasure, that a sum from the Government grant, administered by the Royal Society, has been allotted to him, in aid of the further work which he hopes to accomplish.*

We may further add, that Mr. Crookes regards thallium as belonging to the silver and lead group of metals, and demonstrated its similar reaction with hydrochloric acid, iodide of potassium, bichromate of potash, sulphide of potassium, &c. He also illustrated various very curious characteristics of the metal, amongst which we may mention the singular property of welding at the ordinary temperature of the atmosphere; a number of small pellets being placed in a tube and submitted to pressure, issued in a perfectly connected tough wire. As yet its economic value and applications have to be discovered. We do not at present perceive any probable photographic application of any of its compounds.

A SHORT LESSON IN CHEMISTRY.—No. 7.*

IN the present lesson I will give you a little information about gold and one of its salts. The leaf which is sold by the dealers in chemical drugs is not always gold; it is more frequently bronze. Of course gold leaf can always be had; and you can easily distinguish the leaf of gold from that of bronze. Take a few drops of pure nitric acid in a test tube, and by means of a glass rod introduce a piece of the so-called gold leaf—if the acid dissolves the leaf, the latter is certainly not gold; it will contain copper and other metals. As a second experiment now take a drop of the solution produced in the first experiment, and add to it a drop of ammonia—an intense blue colour will indicate the presence of copper. For your third experiment take a piece of polished iron wire and dip it into the first solution—metallic copper will be precipitated on the iron wire. In like manner, but by other experiments, any other metal might be detected. But we will suppose that the leaf was not all acted upon by the nitric acid; in this case add a few drops of hydrochloric acid, which will undoubtedly then dissolve the metal; and, since this metal is yellow, you can decide at once the leaf is gold; for there is no other yellow metal that is insoluble in nitric acid, and soluble in nitro-hydrochloric acid.

If you wish to ascertain whether a certain ring or trinket is gold, proceed as follows:—Make a streak with the ring, &c., on a piece of ground glass, or on a piece of unglazed porcelain, or wedgewood mortar; then add to the yellow streak a drop of nitric acid—if the streak is entirely dissolved by the acid, there is not a particle of gold in the trinket; if some portion of the yellow streak remains after repeatedly trying to dissolve it by nitric acid, you may conclude that there is gold in the ring, &c. If you wish to ascertain whether the ring, &c., be alloyed either with silver or copper, or with both, try the following experiments:—Experiment No. 1. Dilute the solution of nitric acid and the metal with a few drops of water, mix intimately, and then add

one drop of ammonia—a blue colour, as before, indicates the presence of copper. Experiment No. 2. Add one drop of the diluted solution to ten or twelve drops of water in a test tube, now add a single drop of hydrochloric acid—if a milkiness is produced, you may conclude that silver may be present; to be sure about this point, allow the precipitate, which is the cause of the milkiness, to settle; then pour off the supernatant liquid and wash the sediment with rain water, allow it to settle and again decant; repeat the washing two or three times—at least pour the sediment upon a clean saucer and expose it to the rays of the sun—if the colour soon changes to a violet-hue, be assured that silver is the metal.

Experiment with real Gold Leaf.—Mix together in a Florence flask, or pear-shaped glass bottle, a couple of ounces of the peroxide of manganese and the same weight of hydrochloric acid, and after the proper arrangement is made for collecting the chlorine which is produced, by means of a perforated cork and a glass tube bent twice at right angles, throw into the vessel containing the chlorine a few sheets of gold leaf, these will immediately be acted upon by the chlorine, and so energetically as to produce flame. That which is produced is a chloride of gold. In this way the chloride might be prepared; but it is prepared otherwise as follows:—Take a mixture of one ounce of nitric acid and two ounces of hydrochloric acid; this is nitro-hydrochloric acid, or the *aqua regia* of the alchemists, so called because it will dissolve the royal metals, gold and platinum. But we do not obtain from this solution of a metal in *aqua regia* a nitro-chloride, we obtain simply a chloride, and it is obtained in the following manner:—

Nitric acid is easily decomposed into its elements, or at least is easily resolved into compounds of the same elements containing fewer equivalents of oxygen, so that one equivalent of oxygen is set free and acts upon the hydrogen in the hydrochloric acid, whereby water is formed and chlorine liberated. The chlorine thus liberated combines with the gold so as to form chloride of gold; naturally by such a proceeding we have in the solution an excess of nitric acid and hydrochloric acid, which must be expelled by evaporation.

If, in this experiment, we were to use one of the coins of the country, which may contain either copper or silver as a part of the alloy, and platinum as an accidental admixture, these metals will likewise be found mixed with the chloride of gold; for instance, the silver will be recognized as a sediment which you cannot dissolve by any new additions of the *aqua regia*, but which, when separated from the solution, is easily dissolved in ammonia, cyanide of potassium, or hyposulphite of soda, showing thereby that the sediment in question is chloride of silver. The copper remains in the solution mixed with the chloride of gold.

In order therefore to get pure chloride of gold, you must either have pure gold to begin with, or you must know how to purify your gold from the silver and copper, either before solution or afterwards. There are various ways to do this. I will tell you how I proceed. I take, for instance, a gold dollar piece which I melt with three five cent. pieces in a small crucible; by this means I can get an alloy containing much more silver than gold; it contains also copper. This alloy I either hammer into a thin leaf, or pass it between a pair of steel rollers, and then dissolve the foil thus formed in nitric acid assisted by heat. In this experiment the nitric acid must be pure. The solution will be nitrate of silver and nitrate of copper; the residue, which is somewhat dark-coloured or sometimes slightly pink-coloured and metallic, is pure gold in the form of a thin film or a powder. By washing, after pouring off the nitrates, we obtain the gold pure and in a state of fine division which is quite suitable for making chloride of gold, for it dissolves in the nitro-hydrochloric acid almost as rapidly as silver would do in nitric acid alone. By evaporation to dryness in a gentle temperature and with precautions, we obtain a residue which, when dissolved in a little rain water, will compensate you in the toning process for any trouble it may have cost you.

* From *Humphrey's Journal*.

The solution of the nitrates above separated from the gold may be evaporated to dryness, dissolved in water and then crystallized. If there is not much copper in the silver used, the crystals can be employed in the formation of your bath in which you float your albumenized paper. Or you may precipitate the silver from the copper by means of hydrochloric acid, and then reduce the well-washed chloride by fusion with potassa or its carbonate.

DEVELOPMENT BY THE FUMES OF AMMONIA.

BY ALFRED VERITY.*

At our last meeting I showed you two pictures developed by the fumes of ammonia, and at the request of our Secretary, Mr. Montefiore, I have come prepared this evening to give you full particulars of the process by which they were produced.

I have been making some experiments with ammonia, which I have no doubt will be interesting to some of the members present.

The fumes of ammonia will not develop every dry plate, but will shorten the time for development of most. This I think is due to the acid being neutralized. But its use may be carried too far; that is, a plate fumed with the same strength of ammonia before exposure, as would be required to develop the same, would be slower than if fumed with weaker ammonia. One part liquid ammonia, sp. gr. 880, to ten of water I have found to work the best; but this will depend to a degree upon the amount of acid in the plate.

I soon came to the conclusion that unless a plate could be prepared that would develop by the fumes of ammonia, there would be very little gain by using it, as it left the film in a very loose state, and what was gained in time would not compensate for the chance of the film slipping from the glass. Again, the ammonia must be driven off before the pyrogallie acid and silver is poured over the plate, or it will be covered with black stains, which spoil the picture.

After many failures I have succeeded in preparing a plate possessing the following qualities:—It will keep; is very sensitive; will develop by the fumes of ammonia in four seconds, all the detail in the shadows coming out; no tendency to spots (if proper care be taken in the manipulation); is easily prepared; and gives clear pictures with every detail.

I do not think it possible to get what is called a hard negative by this process, as any process where the development is so rapid and without silver, must, I think, give a soft tone. It is my opinion the impression made by light on the sensitive film of iodide of silver is instantaneous, and only wants bringing out.

I have succeeded in developing a picture by the fumes of ammonia, 880 sp. gr., with an exposure of less than three seconds to an ordinary gaslight; not only the high lights, but the whole of the shadows were there. Caustic potash will bring out a picture that could not be brought out by fuming.

If you give a plate an exposure in the camera—not sufficient to be developed by liquid ammonia, or any other known developer—if we fume the same (getting no image), and then expose to light for a few seconds, and after this replace it in the fuming box, you will find the picture develop. This is, I think, a great proof that the image was formed, but the developer was not strong enough to bring it out, until the light had advanced it enough to be attacked by the developer. This, of course, is only useful as an experiment, as the picture must of necessity be fogged.

To those photographers who have little patience I can recommend the process as one that will enable them, in five seconds, to see the picture, which, in the collodion-albumen and other good processes, would cause them half an hour's speculation and straining of eyes to see whether the picture is coming out. There are few that have not felt this anxiety when developing the first plate after a few days in the country with the camera. But if this were the only advantage the process possessed, it would be worth little, as photographers, as a body, possess the virtue—patience.

Those who have an objection to the use of ammonia, will find that plates prepared by this process will develop quicker than a tannin plate by the regular developer—pyrogallie acid and acid silver—giving first-rate pictures.

As the eyes are more credulous recipients of information than

the ears, I will, in the course of the evening, develop two plates—giving one one minute's exposure, and the other twenty seconds (to gas); and if, from what you will see, I can induce some of the members to take the process in hand, I am sure by their improvements we shall soon have a Manchester *dry process* as good as any at present in use.

I will now give you the particulars how the plate is used:—The plates must be coated with gelatine, or some other substance, to keep them from slipping. This I do in a very simple manner. After the glasses are cleaned I put them in clean water. I take each plate and let water from a tap run over it for a few seconds: if any grease be present it shows itself at once. I make a five-grain solution of gelatine (Nelson's), as recommended by Major Russell, and filter it through paper while hot. After draining a plate for a second, I pour on the solution warm, in the same manner as collodion: this takes all the water off with it. I do the same a second time, which does for the first portion for the next plate. I then stand the plates on blotting-paper to dry and finish by heat. Nothing could be easier, and we have perfect freedom from dust, which will attach itself to the glass that has been rubbed.

The process will work with any good collodion. I have used seven commercial collodions, all of which give good clear pictures. Some were quicker than others, but there was not very much difference in the intensity of the image.

I prefer a collodion that will give a thick film; this, I find, gives a stronger image than a thin collodion. By giving a plate a coating with collodion and then drying it well, then giving another and sensitizing it, I have been able to get a picture intense enough for a transparent positive. A plate so prepared will develop rather slower, but is very sensitive—the picture first appearing on the surface, and then on the back. This is a proof that the picture is *in* the film, and not *on* the film. With three or four coatings of collodion a picture may be obtained intense enough to print from; but the cost of collodion and silver would be so great that it would not be worth doing. There is some little difficulty in coating a plate with more than two coats; but, if well dried before a fire, and a quick-setting collodion used, it can be done. A plate so prepared will take fifteen minutes in the bath, and will have a dense film of iodide of silver.

The bath I find to work the best is a thirty-five to forty grain to the ounce of water, neutral to test paper. It is quicker than one that is acid, and the pictures will develop with weaker ammonia, and quite as clearly. The principal thing in the bath is to keep up the strength—anything under twenty-five grains giving a weak picture.

We now come to the washing. This I do thoroughly. I have four dishes:—

- No. 1. One quart distilled water.
- No. 2. do. do.
- No. 3. Town water one quart, with three ounces salt.
- No. 4. Town water, with a tap running into it.

No. 1 bath will wash twelve stereo plates. I then charge No. 2 for No. 1, and put fresh in No. 1, making *it* No. 2. I coat the first plate, sensitize, place it in No. 1 bath till the next plate is sensitized, then pass it to No. 2, until I have one dozen stereos in No. 4. I then take each plate and let water from a tap run over it for a few seconds, and stand on blotting paper to drain. I then place them into a dish containing the preservative solution—six at a time. In this they stay four minutes. The solution must be kept moving by rocking the dish. From this the plates are placed on blotting-paper to dry, and before placing in the dry-plate box I dry them by heat. If they are wanted to keep more than six weeks, wash gently for a second under a tap, after coming out of the preservative bath. The salt bath may be dispensed with if they are not wanted to keep more than a month. If the plates are not dried well before putting away they will go brown in the fuming box. The plates will absorb moisture from the air, which leaves them in the best working order. I have developed plates that have been prepared over two months, and find them work well.

The exposure is much shorter than for most dry plates, which I hope to prove to you. I have taken (printed) a picture by an ordinary gaslight in two seconds, and I think, with everything in the best working order and quick lenses, it will be able to take instantaneous pictures in the summer.

Plates coated with the following preservatives will all develop by the fumes of ammonia. I will give you them in the order I have found to answer best, starting with the worst first:—Gallic

* Read at a meeting of the Manchester Photographic Society, Jan. 7th, 1863, and reported in the *British Journal*.

acid; pyrogallic acid; gallic acid and honey; gallic acid and gum arabic; gallic acid and tannin; gallic acid and grape sugar; gallic acid, tannin, and honey; tobacco, gallic acid, and grape sugar; gallic acid, tannin, and grape sugar.

The last is the one I use. It will keep good for months, and may be used over and over again. The plates I intend to develop this evening are prepared in the same solution that I prepared two months ago, with the addition of a little fresh to make up the quantity required. It is prepared in the following way:—

Tannin	200 grains
Distilled water	10 ounces
Gallic acid, a saturated solution in water	10 "
Grape sugar	2 drachms
Distilled water	5 ounces.

The grape sugar is dissolved over a water bath, and filtered through paper. Each solution is filtered separately, and then the three mixed and filtered again. I filter every time I use this. It changes to a sherry-wine colour by keeping. I keep it in the dark, with a small piece of camphor in the bottle. Both tannin and tobacco have a preserving effect upon gallic acid. The reason I prefer tannin to the tobacco (which was what I used first) is that it gives the glossy surface to the plate, which may be brushed when dry, which tobacco does not.

It may be against all the rules of photography to use a reducing agent for a preserving one; but in practice it holds good, as I have proved by experiment.

The following plates will not develop by ammonia fumes, but will by the ordinary method:—

- Protosulphate of iron and honey.
- Plain tannin.
- Gum arabic.
- Plain washed collodion.
- Collodio-albumen.

The fuming must be done in a box with a glass top, such as you see before you. The strength of ammonia I find work the safest is one part liquid ammonia, 850 specific gravity, to two of water, placed in a dish at the bottom of the box. If the plate has had the proper exposure, it will be fully brought out in two seconds; if over-exposed, in one second; if under, four minutes. A picture that will not develop in this time will not be worth much, the film turning brown on those parts not acted upon by light, and not properly clearing up in the hyposulphite of soda. Pure ammoniacal gas will develop a picture that would not come out in the above; but with properly-exposed plates this is too rapid, the picture jumping out in two seconds. Great attention must be paid to the plate while in the fuming box, if the best results are to be had, as the plate must be removed the moment the action has arrived at a certain point, which is as soon as the picture is seen through the negative, as it were on the back, with all the detail. It is first brown, then grey, and will next seem of a yellow-brown: before this yellow-brown spreads over the picture remove it.

The first plates I prepared used to fade if left in the ammonia. The ones prepared now will stand days without fading, and undergo a process of fixing, but take a long time to intensify.

To intensify these pictures any of the ordinary modes will do, if the ammonia be first neutralized. The one I have found the best is to drive off the ammonia by heat, and then use formic acid, pyrogallic acid, and nitrate of silver. Citric acid is very good for transparencies; but is very slow.

Another way I find to work very well is to pour over the plate distilled water, with a few drops of acetic acid, then add the pyrogallic acid and nitrate of silver to the same. This is very quick and will give a jet black negative. Fuming with acetic acid is too strong, and dissolves the picture if left too long.

I fix with hyposulphite of soda.

It may be interesting to some of the members to know the effect other gases have on these plates.

Oxygen: If a plate be transferred from the ammonia into a jar of oxygen, very little change takes place; but if this same plate be again placed in the ammonia, the picture will become much stronger. I have found no change in a plate placed in this gas before exposure.

Chlorine: The action of this gas on a developed plate is to bleach the image, but not dissolve it. If a plate be placed in this gas before exposure, no picture can be developed; no marked change takes place in the film; the sensitiveness is completely destroyed. I have been unable to get a trace of a picture after long exposure.

Hydrogen: This has very little effect on a developed plate. A plate will develop after being eighteen hours in this gas. One developed by ammonia will lose a little density in this gas, but is again restored by ammonia.

Nitrogen will not develop a plate. One developed by ammonia will fade if left in this gas, and will not develop again by ammonia. If a plate after exposure be placed in this gas no picture can be developed afterwards.

Sulphuretted hydrogen will not develop a plate. If a picture that has been fixed after fuming with ammonia be placed in this the image is blackened and intensified. A picture developed by ammonia, and not fixed, will turn brown and fade. A plate placed in this gas before exposure will turn brown, and the sensitiveness is destroyed. The danger of using this gas makes it unfit for photography.

In conclusion, I have to thank you for the patient way in which you have listened to a paper containing little that is new and much that is old, and have only to add, that if I have not been explicit enough on any point, I shall be happy to answer any questions to the best of my ability. I will now develop the plates; and I hope, from the discussion we shall have on them, to go away primed for further experiments.

A SHORT LESSON IN PHOTOGRAPHY.—No. 11.*

If a negative has to be varnished (and it certainly has to be varnished if a large number of impressions are required), it must be made more opaque in the lights, because the opaque parts become somewhat transparent by varnishing. The best impressions, however, are indubitably obtained from an unvarnished negative: and where but few copies have to be taken, I would advise you not to varnish the negative; with great care in the apposition of the sensitized paper upon the surface of the negative you will seldom injure the film. When an injury does take place, it is owing to friction on the one hand, and to moisture in the paper on the other, and finally to irregularities on the surface of the paper produced by unequal drying, especially by artificial heat. If the paper is perfectly flat, and perfectly dry, and laid on the negative without the slightest motion in any direction when once in contact, there will be but very little risk of damage to the film.

Experience has taught us the peculiarities of the action of light when applied to direct printing by contact. The peculiarities alluded to are as follows:—When a negative is exceedingly dense in the opaque parts, the best prints are obtained from the action of diffused light, even sometimes after it has passed through a white curtain or a white sheet; the process naturally is slow, but the effect is very pleasing, because the gradations of tone are correctly brought out; whereas, if the direct rays of the sun were to perform the operation, some parts of the prints would be bronzed long before the others had received the proper amount of actinic action.

On the other hand, if the negative is but a few degrees removed from an ambrotype, that is, if the parts which ought to be opaque are still in some measure translucent, in such a case, I would recommend you to print with the direct rays of the sun at an open window, or even by the aid of such rays condensed by means of a set of reflectors. The operation is very rapid and has to be watched with great care. The best and most agreeable prints are obtained by the former process.

I cannot easily describe to you what length of time is required in the successful operation of printing, because this will vary with the two principal things employed, namely, the light and the negative. As a guide, you may observe the following rule. As long as the paper is preserved perfectly white under the opaque parts of the negative, and when beneath the most transparent parts no bronzing has yet intervened, you may then continue the action; and you may continue it as a general rule until the highest lights are somewhat tinged, or the deepest shades begin to show signs of approaching bronzing.

* From *Humphrey's Journal*.

The paper employed for such impressions is either plain or albumenized; both of these kinds can be purchased of the *very best* quality from the best photographic establishments. Such houses always aim to have the most successful formulae in the preparation of their photographic wares, and spare no expense in obtaining such formulae. It is therefore altogether more to your advantage to buy your paper, collodion, nitrate of silver, &c., from such dealers, than to trouble yourself with their manufacture, in which you will, nine times out of ten, fail in the minutiae. With the same propriety might the shoemaker commence tanning hides, the clock and watchmakers casting wheels, or the surgeon manufacturing scalpels, as for the business photographer to waste his time and money in the grinding of a lens, the albumenizing of his paper, or the fabrication of his chemicals. Rely upon it you can buy them cheaper and better than you can yourself present them. It is well that you should know how all such operations are performed, just as we educate our children in the geography of the Celestial Empire or in the mechanism of a watch or a steam engine, although they may never visit China, or manufacture time-pieces or locomotives.

Albumenized paper is preferred by many photographers to plain paper, and I think justly so for portraits. The only difference between the two consists in the albumenized surface, which contains within itself a sufficient degree of polish to supersede the use of any varnish after the printing, toning, and fixing are complete; besides this, the surface is more uniform than that of the very finest paper. The chemical foundation in either is an alkaline chloride, which, by floating the paper on nitrate of silver or ammonio-nitrate of silver becomes converted into chloride of silver in a state of very fine division, mixed with the nitrate of the alkali employed. The latter salt modifies in a great measure the colour and intensity of the print produced, and so does the albumen.

From this circumstance we account for the different tones in different specimens of prepared paper. Some manufacturers use chloride of ammonium, others that of potassium, sodium, or lithium, in the salting of their paper; each print, on this account, will have a different tone when it leaves the printing-frame. It remains with you to select that which pleases best.

The sensitizing bath may consist simply of a solution of nitrate of silver, containing about 90 grains to the ounce of rain or distilled water, together with a drachm or two of alcohol to each ounce of nitrate of silver. But paper so sensitized is not so sensitive to light, nor is it so quickly sensitized as in a bath containing, in addition to the above ingredients, about half a drachm of ammonia. In the latter bath good albumenized paper does not need to be floated at the very most more than a fraction of a minute; in fact, 20 seconds is abundance of time; if you float the paper longer than this the albumen is very apt to be attacked by the ammonia and to be dissolved by it, to remedy which the alcohol is not altogether sufficient. As soon as the papers are thus sensitized they are hung up, as already described in a preceding lesson, by one corner and dried. When they are thoroughly dry they are ready for the printing-frame.

COMMON PRINTING.—VIGNETTE PRINTING.

Before you proceed to print, see that the glass in the printing frame is perfectly clean and altogether free from any particle of sand, which if allowed to remain beneath the negative, would almost certainly break it when submitted to pressure. Place the negative in the middle of the space with the back in juxtaposition with the glass below, that is, with the collodion film outwards or upwards. The paper is next placed upon the negative with the albumenized surface in contact with the collodion film. Over the paper lay a sheet of Canton flannel, of vulcanized india-rubber, or of any other soft material, and finally over this place the jointed lids of the frame, and fasten them down by means of the levers and clasps with which each frame is furnished.

If it were intended to print vignette fashion, you will have to be provided with vignette glasses, which are manufactured specially for such operations, and to be had of all respectable dealers. The vignette aperture can be had of any size required; it is formed of a piece of glass stained on one or on either side with a metallic oxide which is burnt into the glass. This stain, however, is a mere film and can easily be ground away of the required shape and size by the lapidary, and then polished. The external parts, being of a red orange colour, intercept or absorb those rays of light which would act upon the sensitized collodion film, whilst through the vignette opening all the rays can act almost with their primitive vigour. Such a glass, or an appendage of such glasses, is placed first on the glass of the printing frame; upon this comes the negative, and the rest of the arrangement will be as before.

The lids at the back of the frame can be opened independently of each other, which allows the half of the print to be examined whilst the other half is kept fixed on the negative, so that the relative position of parts is never disturbed by the examination of either half.

As soon as the print is sufficiently intense, remove it from the frame and place it between the two leaves of a blank book, and proceed with the printing until you have a sufficient quantity for toning and fixing. Whenever you examine the print, the operation must be performed in some corner of the room where the light is feeble; otherwise the print would be injured by an exposure where the light is brilliant.

Here the lesson ends to-day.

Proceedings of Societies.

AMATEUR PHOTOGRAPHIC ASSOCIATION.

A COUNCIL MEETING of the Amateur Photographic Association was held on March 13th, Mr. G. SHADBOLT in the chair. The minutes of the last meeting having been read and confirmed, the following members and subscribers were proposed and elected:—

The Viscountess Jocelyn	George Ottley
Thomas Bell, F.R.S.	Thomas Fothergill
A. R. Hamilton	Rev. H. B. Ingram
The Countess of Rosse	T. H. Powell
F. R. Barclay	S. W. Rivington
John Rivington	George Daglish
Henry Wood	Mrs. Perry
Captain H. Lawson	S. St. L. Blaawn
Dr. Douglas Reed	The Hon. H. L. de Boscawen
Mrs. Spottiswoode	Mrs. Gough
Miss Darby	Mrs. S. Perry
Professor Selwyn	Miss Bagwell
Col. Whitmore	H. A. Hoare
Robert Hudson, F.R.S., F.L.S.,	Professor E. A. Clayden
&c.	D. Nicholl
W. R. Hayward	M. Peaco
H. L. Dymoke	Mrs. C. S. Harris
W. G. Hunter	Capt. W. Knipe
Thomas Fenn	G. H. Hodges
Rev. E. W. Benson	

Mr. GLAISHER asked the Secretary when accounts of sales of members' prints would be made up.

The SECRETARY replied that he purposed making up the accounts of sales in June next, and explained that although the Association had been in existence nearly two years, yet that the first year had been occupied in forming the Society, and collecting the negatives, and that the publication of them did not commence until June last. It was therefore decided by the meeting that the account of sales should be made up and forwarded to members as soon after the 1st of June each year as possible.

The Secretary was instructed to prepare for next meeting of Council a list of members and subscribers who had, and who had not, paid their subscriptions, also a list showing who had, and who had not, received their allotments of prints. The proceedings of the meeting then terminated.

A. J. MELHUSI, Hon. Sec.

IMPERFECTIONS IN ALBUMEN PRINTS.

Want of vigour and contrast.—Supposing the negative to be of the proper intensity, results—1st, from under-printing; 2nd, from a too weak silver solution. In the second case the print is rod and dim on removal from the printing-frame.

The print refuses to tone.—The negative is too weak, or the silver solution too weak.

The print is red after fixing.—Under-toning.

The print has a cold, ashy blue colour when dry.—Over-toning.

The print is yellow in the lights.—1st, accidental mixture of hyposulphite in the toning bath; 2nd, use of an old fixing bath; 3rd, careless washing, the print being left too long without a change of water.

The whites of the prints are not sufficiently pure, but are grey and dirty.—1st, exposure to light; 2nd, use of ammonia-nitrate of silver in damp and warm weather; 4th, contact with ammonia-nitrate paper; 5th, use of damp flannel on the back of the paper; 6th, use of flannel impregnated by frequent use with ammonia-nitrate of silver; 7th, too long exposure to the heat of the sun.

Brown or black stains on the print.—Contact with hyposulphite of soda before fixing.

Marbled spots.—Insufficient absorption of the silver by the paper, from the silver solution being too weak, or from not floating the paper a sufficient length of time.

Red circular spots.—Air-bubbles under the print while toning.

Irregular bronzed marks.—Impurities on the surface of the silver solution.

Red comet-like marks.—Paper floated on imperfectly beaten albumen.

Black spots seen by transmitted light.—Imperfect fixation.

Mealiness.—Too weak a silver solution.

Red freckled spots all over the paper.—A form of mealiness in thick and highly albumenized paper; too weak a silver solution; try an ammonia nitrate of silver solution, if conditions of temperature will permit it.—*The Card Photograph.*

The International Exhibition.

REPORT OF THE JURY ON PHOTOGRAPHY AND PHOTOGRAPHIC APPARATUS.*

Meriting attention from the amazing popularity which it has attained, and the great impetus it has given to photographic portraiture, is the style known as *cartes de visite*, or visiting card portraits.

Photographs of a similar size and style were amongst the earliest examples of the collodion process, but were then undistinguished by any especial title. The name by which they are now known, and the introduction to the public as a distinct class, for which a furore soon began to prevail, is due, it is stated, to M. DISDERI, a Parisian photographer of great eminence, in whose hands these small portraits attain great excellence and variety.

The accounts recorded at various times of the numbers of these portraits produced in different establishments, appear almost fabulous; it may be safely affirmed that they have attained a popularity and extent of circulation altogether unparalleled in the history of pictorial art. The production of albums especially prepared for their reception, and which are now found in almost every household, has become in itself a distinct and important branch of manufacture, and even the production of scenic backgrounds and other accessories for the photographer's studio are amongst the distinct pictorial characteristics creating a separate branch of trade.

Taking precedence in this style, in the British photographic department, are the productions of Mr. H. P. ROBINSON (United Kingdom, 3147), whose card portraits possess great beauty as artistic studies, apart from their interest as portraits.

Mr. W. MAYLAND of Cambridge (United Kingdom, 3125) also claims a notice for the excellency of his pictures in this department.

Messrs. ROSS and THOMSON of Edinburgh (United Kingdom, 3148), and MELLINS of Jersey (United Kingdom, 3188), deserve notice for their examples in this style. The small pictures of ANGEAEN of Vienna (Austria, 670) are not less perfect than his larger ones, of which we have already spoken.

Many other contributors of this style of photograph display high qualities, whilst some, it is to be regretted, are shown, which illustrate how imperfectly an art distinguished generally by its truth, can be practised; a series of card pictures, by BIRNSTING, purporting to be the portraits of the guarantors of the International Exhibition, strikingly illustrates this bad eminence to which reference is made.

An interesting feature in the various displays of photographs, consists in the pictures of life size, produced either directly in the camera, or by enlargement from small negatives by means of the solar camera, or other similar appliances.

Mr. ANGEL (United Kingdom, 3032), and Messrs. SMYTH and BLANCHARD (United Kingdom, 3157) exhibit some fine enlargements.

The contributions in this style from different continental artists comprise specimens of unsurpassed beauty. M. DISDERI of Paris (France, 1461) showing some enlargements in which the perfection of definition is in every way satisfactory.

M. ALOPNE (France, 1462) also shows a series of very large heads, stated to be produced without enlargement, possessing unusual vigour, without the coarseness too often found in these large photographs.

M. NUMA-BLANC (France, 1494) contributes some very fine amplified proofs of great excellence, and are interesting from the fact that the source of illumination in enlargement was not the solar rays but the electric light.

M. DARLOT (France, 1491), to whom a Medal has been awarded for his lenses, is much indebted to them for the excellency of the large proofs exhibited by him in illustration of their powers.

M. GNEMAA of Brussels (Belgium, 358), amongst other fine pictures exhibit an enlarged portrait of the Comte de Flandres, a standing figure from a visiting card portrait, enlarged to about twelve diameters, which, for perfection and delicacy in every part, is unsurpassed by any exhibited. HANSEN of Copenhagen (Denmark, 127), Wornly of Aix-la-Chapelle (Prussia, 1435), and some others exhibit also enlarged prints which are highly satisfactory.

Another class of photographs very popular with the public, but which at a time when the art has obtained such perfection scarcely possesses the same claim to photographic excellence as those already named, are the touched pictures, or those which owe something to the finishing pencil of the artist, who corrects supposed faults, and supplies deficiencies with a pigment approaching as nearly as possible to the neutral tint of the photograph. In some instances this is not all, as the whole picture is remodelled, the photograph merely subserving as a basis for a picture in sepia or Indian ink.

Of this class are some of the portraits exhibited by Mr. MAYALL (United Kingdom, 3123), which have every appearance of possessing much photographic excellence, being very carefully worked in imitation of a mezzotint engraving by the artist.

Another section of touched portraits are those exhibited by HERBERT WATKINS (United Kingdom, 3177), by JOHN and CHARLES WATKINS (United Kingdom, 3178), Messrs. MALL and POLYBANK (United Kingdom, 3122).

Many of these are good untouched photographs; but mixed with them are many more which are worked on, not to the extent of those just described, but still sufficiently to destroy their claim to consideration as specimens of pure photography.

Amongst others exhibiting pictures of merit in this class are BASSANO (United Kingdom, 3036), BARNES (United Kingdom, 3034), H. N. KING (United Kingdom, 3109), together with others; and it may be proper here to state that it was the original intention of the Committee of Advice appointed by the Royal Commissioners to exclude rigorously all specimens of this class. The published conditions definitely stated that such pictures would not be admitted; it was decided, however, at the last moment, when a great many examples of this class were sent in, to give them a place in the department rather than leave a bare space on the walls, which had been allotted to the gentlemen who had sent such pictures as their contributions. Coloured portraiture, with the photograph as a ground work, whilst not strictly entirely belonging to the art, has hitherto been associated with it as one of its lucrative and proper applications, and some very fine examples of such are exhibited in the British department. A member of the Jury holds a prominent position, especially in enlarged portraits coloured in oil; these pictures are not, strictly speaking, photographs, but are produced by the use of a small photographic negative and an enlarging camera, the image being projected on the camera, and traced by hand instead of by chemical agency; the outlines thus obtained are subsequently finished by the painter.

Mr. KILBERS, Mr. MAYALL, and Mr. WILLIAMS exhibit also some very effective oil-coloured photographs, a great charm in which is the fact that whilst acquiring the beauties of colour they have not lost the distinctive truth of photography.

Messrs. GUSH and FERGUSON (United Kingdom, 3084), and LOCK and WHITFIELD (United Kingdom, 3115), have photographs coloured in water colours, on which the most elaborate skill of the miniature painter is expended, giving them qualities in which they rival the best-executed ivory miniatures of the past age. The coloured specimens of McLEAN, MELCHISEN, and HAYS (United Kingdom, 3120) are very distinct, and their excellency demands every praise. The picture contributed by Mr. B. R. GREEN (United Kingdom, 3051) has also distinct features of considerable merit.

Messrs. HEATH and BEAU (United Kingdom, 3090) have charming miniatures, in which the aid of colour is secured with less elaborate manipulation and a more perfect retention of the photographic character of the portraits.

Mr. A. BAOTIERS (United Kingdom, 3051) exhibits a remarkable finely-coloured miniature photographed upon ivory, and a large group tinted in water colours with great skill; he also exhibits an excellent example of what is known amongst photographers as composition groups, consisting of an assemblage of twenty-two portraits of eminent members of the Association for the Advancement of Science. The capability of the photographer's art in correctly defining groups of several persons on a large scale is limited by the powers of his lens. To meet the difficulty, a method of printing from several negatives, originating with Mr. Rejlander, is adopted. The print to which reference is made was printed at thirty-seven different operations on paper 36 inches by 24 inches. Each negative must of course be designed for its position in the picture from the first, and although each portrait may be taken without the presence of any other member of the group, the proper relation of size must be regarded throughout, so as to produce harmony in the finished pictures. The skilful blending of the separate portraits of this group into one harmonious whole is very satisfactory.

Also, associated with portraiture, a variety of photographs are exhibited, which possess great value and interest as ethnological illustrations, especially a series of Indian portraits of native tribes together with several volucres exhibited in the French department.

Allied to portraiture, and more closely trenching upon the domain of art, is the production of *genre* pictures. Of these the productions of REJLANDER (United Kingdom, 3145) and ROBINSON (United Kingdom, 3147) take first rank. In Mr. Rejlander's photographs the most remarkable feature is the perfect rendering of an idea; each picture tells its story without explanation, the models seem perfectly easy in his hand, and the artist does not seem more fettered by his camera and chemicals than he would be by his palette and pencil.

Superior in precision and excellency of the photographic manipulation, and no less excellent as artistic productions, are the pictures of Mr. H. P. ROBINSON, several of which are printed from many negatives. "Fading away," "She never told her love," and many others have obtained a world-wide reputation.

In *lanescope* and *architecture* the progress of photography is illustrated in a most satisfactory manner, as well as in the results of the wet as the dry collodion processes. The pictures of Mr. BEDFORD (United Kingdom, 3039)

* Continued from p. 120.

possess a degree of excellence beyond which it would seem impossible to go. In his productions are admirably united great artistic excellence with perfect command of his materials. His interiors are probably the finest which have ever been obtained by photography, and illustrate the importance of a cultivated knowledge in the selection of time, light, and position.

Mr. HENRY WHITE'S (United Kingdom, 3179) are perfect landscapes, strongly exemplifying the value of artistic feeling in the prosecution of the art.

Mr. VERNON HEATH'S (United Kingdom, 3091) photographs show the high degree of excellence attained by studying the manipulatory details of the process.

Mr. DIXON PIPER'S (United Kingdom, 3135) views have all those charming characteristics which give value to pictures of English landscape scenery.

Dr. HEMPHILL'S (United Kingdom, 3092) photographs relating to Irish antiquities are highly interesting.

The Viscountess JOCELYN, Sir A. K. MACDONALD, and the Earl of CAITHNESS, send contributions which illustrate that in the amateur pursuit of an elegant accomplishment results may be obtained which rival in all excellence the works of the most able of those who practise the art as a profession.

In many of the contributions of the Amateur Photographic Association the same fact is illustrated.

Amongst the contributors who practise dry photography are many whose pictures show that dry plates in skilful hands yield results equal to wet collodion. Mr. DR. SIDEBOTHAM, and WARDLEY, send illustrations of this kind, in which delicacy and softness are secured without any sacrifice of vigour and effect.

Without entering into lengthy detail or comparison where so much excellence exists, the names of ROGER FENTON, FRITH, STUART-WORTLEY, D. CAMPBELL, LYNDON SMITH, B. B. TURNER, and others, may all be mentioned as admirable illustrations of the excellence which has been attained in the branch of landscape photography.

(To be continued.)

Photographic Notes and Queries.

SPOTS IN DRY PLATES, &c.

DEAR SIR,—In reply to Mr. Branfill's letter in the NEWS of last week about Spots on Dry Plates, I have little hesitation in saying that they are caused by the albumen.

When I first began Major Russell's excellent tannin process I always used gelatine as a preliminary coating; seeing however somewhere a recommendation that albumen should be used for that purpose, I carefully tried it, both plain and iodized, when spots of imperfect development at once appeared, besides a great tendency to stains. On returning to the gelatine, they did not present themselves, nor have I ever been troubled with them since.

During the last month or two I have been making experiments for the purpose of obtaining rapid dry plates, and I am glad to say that I have, by a modification of the tannin process, succeeded in getting a fully exposed negative with "Ross's" single stereo lens of 4½-inch focus with fixed stop (two-tenths inch) in ten seconds, the detail well out and the clouds beautifully rendered.

I purpose attempting to take an instantaneous street view, so soon as I have an opportunity on a favourable day, and if successful, will send you a print.—I am, yours truly,

JOS. T. HURST.

Mirfield, March 30, 1863.

SPOTS ON DRY PLATES.

DEAR SIR,—The principal cause of spots on dry plates I think arises from the bad quality of the glass. I have had many samples of prepared plates brought for examination, afflicted with this disease, and in ten cases out of twelve trace the mischief to the glass. In my own practice I am not troubled with it since adopting the following simple

Rule.

Take a few plates from the packet, or stock of glass intended to be used for dry plate photography, clean them by the method generally used, breathe on each plate, closely observing whether any spots appear, if so, such plates are worthless. But should the breath dry off, leaving the plate clean, proceed with the test. The cleaned plates are to be placed in the plate box and left for a week or so; if after that period spots are not produced by simply breathing on the plate, they may be used with safety. I find it necessary to try every description of glass, as none is free from this defect, which defect arises in the annealing oven. Another, but not frequent cause, by mixing an old powdery collodion with a new and glutinous one, and using it too soon after mixing.—Your obedient servant,

H. R. NICHOLS.

2, St. Jude Street, March 28, 1863.

Miscellaneous.

THE MOON PIRACY.—We recently published an abstract of a correspondent between Mr. Warren de la Rue, Dr. D'Orsan, and others, respecting an alleged piracy by the last named gentlemen of Mr. De la Rue's photographs of the moon. Some further correspondence has transpired without anything being elicited to establish the originality of the photographs in "Our Satellite." Dr. D'Orsan finally entrenching himself behind his dignity will "give no reasons on compulsion, though they were plentiful as blackberries." The *London Review*, in a caustic article on the subject, supplies some evidence of Dr. D'Orsan's capabilities of literary appropriation as illustrative of a possible similar propensity in scientific matter, and gives the following passages in juxtaposition, the first from Dr. Chalmers' Sermons, edited by the Rev. William Hanna, published by Constable, Edinburgh, and Hamilton and Co., London, 1855, vol. iii. page 20:—"Who can question it? What is seen may be nothing to what is unseen, for what is seen is limited by the range of our instruments. What is unseen has no limit; and though all which the eye of man can take in, or his fancy can grasp, were swept away, there might still remain as ample a field . . . which the Divinity . . . may have peopled with innumerable worlds." From D'Orsan's "Our Satellite: or, Selenography according to the present State of Science," Part I., page 17, published 1862;—". . . For who can question it? What is seen is nothing to what is unseen; for what is seen is limited by the range of our instruments. What is unseen has no limit; and though all that the eye of man can take in, or his fancy can grasp, were swept away, there might still remain as ample a field as ever, which the Deity might have peopled with innumerable worlds." The *London Review* adds, "The remarkable similarity of these passages may be accidental. But considering there are many more examples, if M. D'Orsan should hereafter prove himself innocent of having taken to himself words and views that belonged to others, it will still have to be recorded as an inexplicable psychological fact that he thought exactly like Chalmers, and photographed exactly like De la Rue. There is but one course open to M. D'Orsan. Let him at once state the dates on which he took his photographic views—if he ever took them at all; let him say where they were taken, with what telescope; and these three data given, the scientific knowledge possessed of this particular subject is such, that the truth or falsity of any statement could be made intelligible to every child in the kingdom. If he has been guilty of copying, let him boldly aver it, and render De la Rue the justice that is due to him. For proving his right no testimony of witnesses is required, no challenges nor inspections are needed. But if M. D'Orsan refrain or hesitate to speak, the conviction in every competent mind will be dead against him."

PHOTOGRAPHIC ILLUMINATIONS.—In connection with the important part photography has played in the late public rejoicings, its application to the purposes of illumination was not the least interesting. On the night of the 10th many of these were displayed, but most notable was that at Messrs. Carpenter and Westley's, opticians, in Regent-street. It consisted of a series of portraits of the Royal Family, as dissolving views. The portraits were coloured photographs, surrounded with appropriate wreaths of flowers, and illuminated by the oxyhydrogen light. The subjects comprised the Prince of Wales; the Princess of Wales; the Queen; the late Prince Consort, &c. The portraits were followed by views of the Royal residences—Windsor Castle; St. George's Chapel; Osborne House; Whippingham Church; Balmoral; the Horse Guards; &c. The exhibition, which commenced at seven p.m., was continued till two a.m., and, at this latter hour, the crowd was as great as it was at eleven. The spectators never numbered less than from 8,000 to 10,000 at a time, and the way was completely blocked from Piccadilly down to the Club Chambers, Regent Street, and as far down Jermyn Street as brought the exhibition within eye-shot, and the loyalty manifested by the spectators was enthusiastic; several times they burst out spontaneously with the National Anthem, and when the words—"God bless our widowed Queen," were exhibited, dissolved into a portrait of the Queen herself, which was again dissolved into "Albert the Good," with the lines from Tennyson's Ode:—

"Oh silent Father of our Kings to be,
Mourning in this golden hour of jubilee"—

the murmur of mournful sympathy which ran through the immense assembly was eminently touching. When a portrait of the late Prince Consort himself followed, the cheers with

which it was greeted were enthusiastic. Among the miscellaneous series was a portrait of Garibaldi, which was received with shouts of delight. So orderly was this vast assembly, that "Good Night" being put in at the very moment when the pressure was at its highest, the thousands who had caused a dead block instantly dispersed, having first given three cheers for Carpenter and Westley. It is calculated that this singular and most attractive exhibition was witnessed by upwards of 200,000 persons.

Talk in the Studio.

ENAMEL PAPERS.—We have received from Mr. J. Spencer, of Enoch Square, Glasgow, an intimation that he is the agent for the enamel paper of which we had recently occasion to speak in very high terms. There is, however, some doubt in our minds as to the identity of the paper. The paper for which Mr. Spencer is agent, is, he states, prepared by Schering, of Berlin, who exhibited some very fine photographic chemicals in the International Exhibition. That which we tried we received from Herr Paul Liesegang, Editor of the German journal; but as his father is, we believe, connected with the preparation of photographic papers, it is probable that the paper was prepared by him and not Schering. Mr. Spencer is, then, the agent for an enamel paper, which may be as good as that on which we reported, but which at present we have not tried. We shall probably report on it on receiving a promised sample. Messrs. Johnson and Matthey are Mr. Spencer's London agents.

AMATEUR PHOTOGRAPHIC ASSOCIATION.—The firm of McLean, Melhuish, and Co., having dissolved partnership, the offices of the Amateur Photographic Association will henceforth be at the establishment of Mr. Melhuish, the Secretary, 12, York Place, Portman Square.

PHOTOGRAPHS OF THE ROYAL RECEPTION.—The preparations made by many photographers for photographing the various phases of the royal procession on the 7th, turned out in the majority of instances comparatively useless, from the unfavourable nature of the light. The best we have seen are those of Mr. Blanchard, at Gravesend. These comprise the *Victoria and Albert*, the *Raceon*, the *Black Eagle*, the *Emerald*, and other vessels, decorated from stem to stern with flags, and some with yards manned. They are soft, pleasing pictures and pleasant memorials of the occasion. An interesting view of the triumphal arch and waiting crowd at Gravesend was obtained by Messrs. Le Beau and Rust, of Bayswater. Mr. Rolfe, of Graecelureh Street, obtained some views of King William Street and London Bridge during the procession, but the light being insufficient for instantaneous work, these are under exposed.

To Correspondents.

- A. B. C.**—We cannot decide certainly the cause of the stains on your background from seeing the print, as such stains might occur from a variety of causes, you should state their appearance on the negative, and at what period they occur.
- J. H. S.**—You may without impropriety mix the two collodions of which you speak. A bath prepared for bromo-iodized collodion and iron development will probably contain nitric acid, which is not desirable in a bath intended for pyro development, and will probably cause the want of intensity of which you complain. Add a little bicarbonate of soda to neutralize the nitric acid, if you find you cannot get intensity without; but we should recommend you, for portraiture at least, to stick to iron development. We shall publish next week a new intensifier, which will, probably, help you.
- J. HAWKE.**—The definition in the prints referred to certainly does not exceed that of the prints received, nor are yours inferior in brilliancy to any we know.
- F. L. G.**—You may repair your glass bath by the aid of marine glue without hesitation. It will not act on the solution injuriously. We have cemented the ends of dippers on with this material, and used them for years without disadvantage.
- G. M. Amsterdam.**—The double sulphate of iron, to the use of which a great impetus has been given by the experiments and recommendation of M. Meynier, was first suggested by the PHOTOGRAPHIC NEWS, and is the salt described on page 374 of our last volume.
- CUMBERLAND.**—A print being too dark in the face when it comes from the pressure frame may arise either from over-printing, or want of vigour in the negative. In your case, probably, the latter. Your negative, perhaps, is too thin—lacks deposit. You require a much denser deposit of silver on the lights of a negative than on a collodion positive. Try to procure from some more experienced photographer a sight of a good negative; or, better still, the possession of one, as a guide. You will thus save yourself many disappointments in working to find out the right thing.
- GEORGE WHARNCLEIFFE.**—Various articles on plain-paper printing have appeared in our pages. You will find succinct instructions on p. 405, Vol. iv., of the PHOTOGRAPHIC NEWS, under the head, "Dictionary of Photography." We should recommend you, however, to use the process with resinized paper, as minutely described in our columns by Mr. Cooper. With all the general characteristics of plain paper you will obtain greater richness and vigour,

A CONSTANT SUBSCRIBER.—We do not know the constitution of the collodion in question; but, in all probability, it will still answer your purpose. Try it first for a wet plate, and ascertain if it have lost its sensitiveness.

2. Some operators excite both the collodion film and the albumen film in the aceto-nitrate bath. **3.** It will, probably, be a little slower; but, otherwise, we see no disadvantage. **4.** If you use ground glass, on which to print your transparencies, by all means use the plain side. It is customary, and for some reasons better, to use plain glass, and back with ground glass or a dead varnish. **5.** As the human eye sees a little more of the right side of an object with the right eye, and of the left side with the left eye, you must mount your slides in accordance with this law, i. e., you must give a little more of the right end of the right half, and of the left end of the left half. A bluish-white eard will not give a good effect to the print mounted thereon.

W. L. NOVEAEE.—Thanks for your communication. We shall be glad to learn your further experience with the developer, and also to see the specimens.

JUSTITIA.—So far as we can judge from a hasty inspection of your model, your glass house is exceedingly well arranged, and ought to permit very fine effects. In order to judge satisfactorily we ought to have some illustrations of the defects complained of to examine as well as the model. We will answer more fully in our next. In the mean time send us a few of the defective prints.

J. S. II.—So far as we can understand the defect you describe, it appears to arise from the use of an unsuitable collodion. Either an older sample or one with a more powdery and permeable texture would probably answer better. With Keene's process, we should recommend you to try his collodion.

SUBSCRIBER T.—The acetate of soda and gold toning bath should not become black; nor have we known it do so. We have seen it become purple, which indicates that some cause is in operation reducing the gold to a metallic state, and of course spoiling the bath. **2.** We do not remember such a table of a general character. **3.** The presence of nitrate of soda in a solution of nitrate of silver does not appear to produce any injurious results. It is of course accumulating in either negative or printing baths where sodium is the base of the iodide or chloride used. **4.** Stains caused by hyposulphite of soda coming into contact with the print before fixing cannot be removed.

CHARLES AUSTRONIUS.—We do not clearly understand what you mean by the "gas-light process." There is no method of producing negatives by gas-light. Transparencies may be printed by superposition by gas-light; but it is not sufficiently powerful to give a picture by exposure in the camera.

WM. FOX.—The address of Dr. Diamond is Twickenham House, Twickenham. Mr. Henry was the gentleman in charge of the Exhibition as curator. His address is, we believe, 78, Hatton Garden. Your eards are very good. There is, however, one point worth modifying: character figures like "Happy as a King" should not be seen against a smooth, clean, light background, as though standing for a portrait. Either a suitable suggestive pictorial background is desirable, or a rough wall, or a background broken into irregular masses of shade.

AMARANTH.—It is possible to produce an enlarged negative from a small one; but it requires skill and experience. There is generally some slight loss in the enlargement; but in skilful hands very little. Of course the less amount of enlargement, the less probability of loss in the definition. If the small negative be very perfect, and the enlargement be managed with judgment, a negative magnified, say six diameters, may be produced to give good results.

TRAVELLER.—The Photographic Exchange Club is still in existence. The address of the Secretary is F. Howard, Esq., 10, Lansdowne Road, South Lambeth.

PROS.—Pinholes may proceed from a variety of other causes besides the condition of the bath; but if you are satisfied they proceed from it, add carbonate of soda until there is a slight precipitate, and then sun the solution, which will probably reduce the foreign matter present, which causes the abnormal action.

GEORGE QUILTER.—If you forward one of the printing-frames you mention, we shall have pleasure in noticing it.

A. R.—There is no work published containing the details you require, but they are scattered through many articles in our pages. Mr. Osborne's article on photolithography, on p. 484 of our last volume, contains much practical information on the subject. Mr. Postlevin's work on printing without the salts of silver also contains some account of it.

G. H. C.—It is better always to wash between toning and fixing, although many who use the bath of acetate of soda first dispense with such washing. **2.** In using bichloride of mercury and iodide for intensifying, the yellow colour depends more on the strength or time of application of the mercury than of the iodide. If the mercury has acted too long, a very weak solution of iodide will turn the film yellow at once; but if the mercury be allowed to act but very slightly, you may apply a one-grain solution of iodide for some minutes, increasing the intensity without producing the yellow tint.

THOS. JOHNS.—The plan is good, but if the light be increased a little at the top it will be better. See our remarks a few weeks ago on the subject, and Mr. Rejlander's in our present number.

A. WOOD.—The illustrations of your proposed method of inking are very interesting. So far as we can judge there is less difficulty in getting half-tone on the stone than in printing it. But we hope by the aid of skill and perseverance that both will yet be done. A correspondent asks if you will detail the whole of your operations?

Photographs Registered during the Past Week.

- MR. WILLIAM DOWNEY**, 9, Eldon Square, Newcastle-on-Tyne,
Three Portraits of Lady Don.
One Photograph of Dante Gabriel Rossetti.
- MESSRS. H. PETSCHLER AND CO.**, 84, Market Street, Manchester.
Portrait of Rev. Nevison Lorain.
" of Rev. John B. Kenneley.
" of Rev. T. R. Bentley.
- MR. A. S. WATSON**, 2, Regent Road, Great Yarmouth.
Photograph of "Officers of the Norfolk Artillery Militia."
" of President Lincoln, covered with Portraits of his Friends.

THE PHOTOGRAPHIC NEWS.

Vol. VII. No. 240. April 10, 1863.

CONTENTS.

	PAGE		PAGE
Ammonia Fumes in Printing	169	Photography and Bad Taste	174
Photographs in Printing Ink	169	Photographic Piracy of Engravings	175
How to Print in Skies from Separate Negatives. By Wm. L. Noverre.....	170	Proceedings of Societies.—London Photographic Society.—The American Photographical Society.....	176
Report on the New Fixing and Developing Agents	171	Correspondence.—Foreign Science, &c.	178
On the Most Recent Spectrum Discoveries. By Professor W. Allen Miller, F.R.S.	172	To Correspondents.....	180
A Short Lesson in Photography.—No. 12	173	Photographs Registered during the past Week	180

AMMONIA FUMES IN PRINTING.

THERE are some singular discrepancies of experience in connection with this process which require clearing up before it can become of practical benefit to photographers. Our readers have already had some record of failures in connection with it; but, with a promised improvement in the production of photographic prints, we are unwilling to allow a few failures to stand in the way, or condemn the plan as entirely useless. At present the experience is singularly conflicting, and we wait for further and more definite information before we can arrive at a decision on the question.

In our last, we gave a communication from Mr. Penny, of Cheltenham, in which he detailed his experiences, which were very strongly in favour of the fuming. Its effect, as illustrated in the specimens we received, appeared to be a great increase in sensitiveness, and a greater richness and depth of tone; the same treatment in toning giving decidedly greater depth. This experience coincides with that of various American authorities who have given opinions in favour of the process. The experience of some other operators, however, is not only opposite, but is very anomalous and varied. Mr. Debenham, who stated the results of some experiments at the Photographic Society last month, found, absolutely, no difference in the final result between the paper which had been fumed, and that which had received no such treatment. Mr. Hughes, in detailing to us the results of his own experience, described the fumed paper as assuming a greyish-blue tint in the pressure frame, and retaining that colour, more or less, whilst toning, fixing, &c., and after it was finished; the print being neither so warm or so vigorous as others from the same negative printed and toned in the usual way. We have recently been trying some experiments ourselves, and we meet with results, in many respects, decidedly the opposite to these; but still, in our estimation, a failure. We will detail exactly our operations.

We used Saxe paper, highly albumenized, and salted with seven grains of ammonium and one of sodium to the ounce, and which, by the ordinary treatment, gave us very good results. This was excited on a bath originally neutral and sixty grains to the ounce, but reduced by working to a little under fifty grains; having just been decolorized with a little chloride of sodium a slight trace of nitric acid was set free. Sheets of paper excited on this bath were divided, one half fumed, and the other left as it was. The fumed half and the other half were printed together on halves of the same stereoscopic negative. The fuming was effected by placing a saucer containing a little of the strongest liquor ammonia in a box, to the lid of which the sensitive paper was pinned. The first floating of seven minutes slightly attacked and disintegrated the albumen. Subsequent fumings of the same duration and of about five minutes did not show any such result. The effect in printing was altogether different to what, from the experience of others, we had been led to anticipate. In the first experiment the fumed paper required an exposure of about

one-fourth longer than that which had not been fumed. It printed much redder, and with more contrast or brilliancy, and these characteristics continued throughout subsequent operations. When toned in the same acetate and gold bath, it coloured a little more slowly, and remaining in the bath for the same time, as also in the fixing bath, final washings, the finished print is redder, lighter, and possesses a little more contrast than the other half which had not been fumed. Other experiments were similar; in some cases the amount of sensitiveness seemed equal between the fumed and the unfumed paper; but in all cases the tone was redder in the pressure frame, and continued so to the end of the chapter. In some cases there was a little more contrast in the fumed specimens, but in no case either greater sensitiveness or depth of tone.

We must confess that however promising some of the results may have appeared, we fear there is too much uncertainty in the very nature of the process to give promise of much practical value. In fuming we have no means whatever of arriving at certain or uniform results. Whatever the action of the ammonia may be, we have no means with such a process of fixing the exact extent of the action or the amount of the combination. Even if the same time be given to each sheet, the result must vary for the strength of the ammonia is constantly changing by the evaporation. The presence of ammonia fumes in any part of a photographic establishment, is moreover scarcely desirable. If the good were certain and definite, this might doubtless be got over; but we fear that until the conditions of success are more accurately defined, tempting as the promise of perfect prints may be, the fuming process will not prove of much practical value to photographers.

PHOTOGRAPHS IN PRINTING INK.

WE have recently been favoured by a visit from Mr. Pouncey, when he showed us some specimens and made some explanations which give a more specific meaning to the term "photographs in printing ink" than it has seemed to possess in a recent correspondence which has appeared in the *Times* and some portions of the photographic press. By the use of this term Mr. Pouncey does not simply mean prints from blocks obtained by the art of photography, as in Herr Pretsch's productions, nor photolithographs or photozincographs, nor even the photographic transfer produced in printing or other greasy ink; but positive prints produced direct from the negative in the compound of carbon, oils, and varnish, known as printing ink.

The mode is the subject of a patent, the specification of which will not be published for a few months. We are at liberty to say, however, thus much of the method of operation. A suitable photographic paper is covered by means of a brush with a preparation of printing ink containing a salt sensitive to light, and affected in the same way as the bichromates. This is ready for exposure under a negative in a quarter of an hour, or it may be kept without deteriora-

tion for months. The time of exposure varies of course with the quality of the light and the character of the negative; but generally exceeds, somewhat, the time required by a silver print.

The whole surface of the paper being black, the progress of printing cannot be seen as in the ordinary process, but may be ascertained by other methods, of which there are two or three available. When the proper exposure has been given, the print is placed in a solvent of the ink, which dissolves and removes the whole of that which has not been acted upon by light, leaving the photograph with its blacks in printing ink as though it had been produced by the printing press.

This is somewhat similar in principle, it will be seen, to some of Mr. Pouncy's early experiments in the carbon process, the whole paper being covered with the black pigment in combination with a salt which serves as a mordant under the influence of light.

It will doubtless occur to many that it will be difficult to obtain perfectly clean lights by any process in which the white paper has once been covered with a black pigment in a greasy vehicle. This, Mr. Pouncy assures us, is purely a question of material and manipulation. In the specimens we have seen there is perhaps a little to be desired as regards colour, a slight tendency to degradation in the whites being manifest; but in many respects they are very satisfactory and full of promise. They are subjects from nature, and the half tone is very perfectly rendered, whilst the shadows are deep and transparent, possessing in this respect a great advantage over most of the photolithographs we have seen. We shall look with interest for the further development of the process.

HOW TO PRINT IN SKIES FROM SEPARATE NEGATIVES.

BY WM. L. NOVERRE.

Now that white skies are going out of fashion, and photographers do their best to obtain either clouds or a tinted sky, the description of a method for producing such results may be of use to those unacquainted with it. Most of the good photographs in the last exhibition of the London Photographic Society had clouds or a tint on the sky, and no one having seen such productions can feel satisfied with a photograph having a white sky or rather no sky at all. The method about to be described will be found simple and effectual if the directions are carefully followed out.

In printing in skies from cloud plates a print must first be taken of the building or landscape about as dark as it is intended to remain after toning and fixing. Examine it on removal from the pressure frame, if the sky is white and free from spots, the negative requires no preparation; it may however happen that the sky prints through, or that there are spots and markings on it, in this case the sky must be cut out with a pair of scissors to within $\frac{1}{4}$ th of an inch of the outline of the picture; this will form a mask for the sky; a mask must next be cut for the landscape, making it rather smaller by cutting it $\frac{1}{4}$ th of an inch within the outline. These masks must be exposed to the light till they are blackened, they are then washed to remove the free nitrate, and dried. We now gum the mask on to the sky on the varnished side of the negative, so that there will be $\frac{1}{4}$ th of an inch left between the edge of the mask and the outline of the landscape; this interval is to be filled up with Indian ink laid on with a camel hair brush. It is convenient to keep some mixed up pretty thick with water in a bottle; it is then always ready for use. To apply the Indian ink, hold the negative upside down between the eye and the light, then trace round the outline on the varnished side. If the Indian ink is thick enough, one coating will be sufficient. The addition of gum would give the ink more body, but it is liable to crack and pull off the negative after a time. The negative is now ready to print from; this is done as usual; on removal from

the pressure frame the sky should be white and free from spots. We must now completely mask the landscape, leaving nothing visible but the white space above, on to which the clouds are to be printed. To do this, take the mixture of Indian ink and with a small brush paint over about $\frac{1}{4}$ th of an inch within the outline of the picture, taking care not to allow the brush to touch the white part of the print, as it would leave a white mark in the finished picture. Should the brush happen to slip, do not attempt to wash off the paint, as doing so would produce a stain on the sky by removing the free nitrate. Not painting quite up to the edge will not signify, and will be scarcely perceptible in the picture when finished. When the painting is done, lay the paper mask on the landscape, allowing it just to overlap the lower edge of the paint, gum it on either side to the part which will be trimmed off, next lay the sensitized side of the print on the sky plate, hold them up between the light and the eye to ascertain that the right part of the plate will print on to the picture, place them carefully in the pressure frame and print as from an ordinary negative; on removal from the frame place the print in a dish of water to remove the free nitrate and the Indian ink; as soon as the gum has become soft, remove the mask and put by for the next print. The Indian ink may be easily removed with a paint brush, or by gently rubbing with the finger; after proper washing the print will be ready for toning, and if the operation has been carefully carried out no join will be seen between the outline of the landscape and the sky. The masking, &c., must be done in yellow light or by the light of an ordinary lamp, which is to be preferred for laying on the Indian ink. Should there be any white spots on the finished print from the brush having been allowed to go beyond the outline, they must be touched out with water colour.

A photographer having no cloud plates may produce a tint on the sky, which has a remarkably pleasing effect, in the following way. The negative must be prepared in the manner directed for printing in clouds; a proof is then taken, and when at the proper depth remove it from the pressure frame, mask the landscape exactly as described for cloud printing, lay a glass plate over the print to prevent it shifting about, place a piece of cardboard rather larger than the print over the plate, take this arrangement into the light, or sun, if it shines, place it on the ground or table, move the cardboard screen backwards and forwards from the edge of the landscape to within a short distance of the upper edge of the print, an evenly graduated tint darker at the top and getting fainter as it approaches the horizon will be the result. The print can afterwards be treated as in the case of printing in skies; this tint can often be obtained without using the Indian ink, the paper blind being placed a little over the outline of the subject, it need not be gummed to the print as the glass plate will prevent its moving. In sunning down, the screen must not be allowed to come below the mask, or there will be a sharp edge following its outline. It is only in the case of a subject having a very irregular outline that the first plan need be resorted to. From the description I have given many may be discouraged by its lengthy description and apparent complication to attempt the process, it will, however, be found very simple in practice and the effect produced will amply repay any trouble that may be expended on it.

The negative, when once prepared, will do for any number of prints, as likewise the paper masks; these may be numbered the same as the negatives, and kept between the leaves of a black book, the pages being numbered consecutively, and with corresponding numbers, so that any blind may be readily found when required. The line of paint round the print does not as a rule take more than about five minutes for a 10 by 8 print, and as the negative is not required any more, another proof may be printed from it whilst the first is having the clouds printed on to it. The process of sunning down may be used to produce even backgrounds on portraits when from any cause, such as from their having been taken in the open air or otherwise the background is

defective; in this instance the tint should be light over the head and darker as it approaches the feet. The above method of masking might be applied with advantage to composition photographs, we should not then see the line of paint round the figure which has to be stippled in with much care and labour after the print is finished, and which may be noticed in many composition pictures.

25, South Street, Park Lane.

REPORT ON THE NEW FIXING AND DEVELOPING AGENTS.

PRESENTED TO THE FRENCH PHOTOGRAPHIC SOCIETY BY
M. DAVANNE.

At the meeting of the society held on the 9th of January last, M. Meynier presented two salts applicable to photography: the one as a developing agent to replace the ordinary sulphate of iron, the other as a fixing agent to replace hyposulphite of soda. A Committee consisting of MM. Périer, Bayard, Girard and Davanne was appointed to make practical experiments on the employment of these salts, and I have now the honour of giving you an account of the experiments made by the Committee.

The new developing agent proposed by M. Meynier* is the double sulphate of iron and ammonium; previously known to chemists and described by Berzelius together with the analogous salt of iron and potassium: but hitherto it has not been employed in photography.

The Committee first tried if the proposed salt developed negatives properly, and it was unanimously agreed that the photographic picture was developed very pure and soft under the action of the double sulphate. This agent may therefore replace both sulphate of iron and pyrogallic acid: but as to the question which developer is to be preferred, there was considerable diversity of opinion, and in fact it is a difficult if not an impossible question to solve, that of knowing which among several products giving good results is to be preferred: for it depends upon a host of different circumstances, and the best must be replaced at a given moment by another, if the conditions are no longer the same: thus when a photographer finds his negatives too grey and inclining to *fog*, it will be advantageous to employ the double salt proposed by M. Meynier: but if with the ordinary iron bath the negative comes pure, the greater purity due to the double salt will give a dry aspect to the picture.

The inventor of the process gives the following formula:—

Double sulphate of iron and ammonium	5 parts
Water	500 "
Pyroligneous acid	20 "
Alcohol	10 "

In our experiments we found the quantity of pyroligneous acid too large, and we have been able to reduce it one-half without inconvenience; that is, 10 parts acid to 100 parts water. The addition of alcohol is not absolutely necessary: it is useless, if the developer flows over the glass well; but, if it forms a greasiness upon it, alcohol must be added, little by little, until equilibrium is established.

The double salt is very easily prepared: it suffices to take 2 parts of sulphate of iron and 1 part of sulphate of ammonia, and dissolve them in a porcelain dish by means of 4 or 5 parts of warm water. When completely dissolved, the solution is filtered and left to crystallize: the mother water can be employed in making a second solution. The crystals drained and dried upon bibulous paper are ready for use. The salt is preserved in a solid state in a well stoppered bottle: the solution may be prepared a long time in advance; it finally acquires a brown tint, which does not alter its properties in any respect.

M. Meynier has presented us with a new re-agent, endowed with valuable properties: it remains only for operators to learn the use of it.

The second salt proposed by M. Meynier offers still greater interest, for he assumes to replace by sulpho-cyanide of ammonium, the hyposulphite of soda, which is the cause of so many spots and much fading. The committee thought that by leaving to MM. Davanne and Girard the theoretical researches which belong to their general study of positives, they could especially occupy themselves with the practical side of the question, and their experiments, as yet but few, in consequence of the deficiency of material, were all in this practical direction.

We first undertook to fix some negatives, and we satisfied ourselves that well washed negatives, upon which a saturated solution of sulphocyanide of potassium is poured, are fixed almost as rapidly as with cyanide of potassium; pouring off the solution, we wash the negative, and if the washing causes a white precipitate to appear upon the plate, it is sufficient to quickly pour a second quantity of the fixing solution in order to remove it completely. During this operation, a light sulphurous odour may be disengaged, arising from the mixture of the acidulated sulphate of iron with the sulphocyanide of ammonium: but this odour will not appear if the negative has been well washed, nor if the liquid does not drop into the same dish as the sulphate of iron. A rapid washing concludes the operation of fixing.

This method of fixing presents the advantage of replacing so dangerous a substance as cyanide of potassium by a body which we have reason to believe is inoffensive—and of substituting, for fixing with hyposulphite of soda, which always acts slowly, and demands the greatest precautions to avoid spots in the subsequent preparations—a much more rapid fixing, and without giving spots, even when a considerable quantity of the salt adheres to the fingers. The fixing of paper positives, which we carried on simultaneously with a fixing with hyposulphite of soda, has given us results comparable with the latter.

The proofs, a little deeper toned than usual, and washed, were placed in a bath of sulphocyanide of potassium, strength 30 per cent., then washed. In consequence of a chemical decomposition, this washing immediately gives a white precipitate of sulphocyanide of silver, part of which remains on the proof: this must be removed by a second fixing in another solution, also at 30 per cent. After these two fixings, the washed proofs exhibit an aspect exactly identical with those fixed with hyposulphite of soda. We must advise photographers that all the operations of fixing with sulphocyanide of ammonium must be conducted in dishes which have not been used with hyposulphite of soda, otherwise the proofs will be immediately spotted and spoiled.

Your Committee has not entered upon the economical question, not but that it is a question of great interest, but they thought it was quite secondary to that of the probable permanence of the proofs; and, moreover, from the moment that a substance enters into general consumption, we may leave it to the talent and interest of manufacturers to reduce the cost as quickly as possible. While on this subject, we may remark that pyrogallic acid, at first ten shillings the drachm, is now twopence. Besides, many large manufacturers have assured us that this new salt can be sold nearly as cheap as hyposulphite of soda.

Your Committee is therefore of opinion, that as sulphocyanide of ammonium may replace hyposulphite of soda in fixing positives, without their exhibiting any appreciable difference, that they are justified in recommending photographers to introduce this salt into their daily practice; it is only by operating on a large scale that the advantages and possible inconveniences of this salt can be appreciated, and which the laboratory experiments may not have sufficiently made evident.—*Bulletin de la Société Française de Photographie.*

* The use of the double sulphate of iron and ammonia was first suggested by the PHOTOGRAPHIC NEWS.—See vol. vi. p. 374.

ON THE MOST RECENT SPECTRUM DISCOVERIES.

BY PROFESSOR W. ALLEN MILLER, F.R.S.*

THE subject of the lecture, the learned Professor said, was, perhaps, the most extensive and fascinating which presented itself to scientific men. On the present occasion he intended to limit himself to but a few of the interesting discoveries made in this great field of research, and hoped he should not be considered egotistical if he referred to his own experiments. Among the rays emitted by the sun there were three kinds, interesting as endowed with special action—those which conveyed heat, light, and chemical action. With heat he should have but little to do on this occasion; about light he had something to say; but he was now principally concerned with the rays which manifested themselves by producing chemical action. It was well known that transparent substances did not transmit all these rays with equal facility. Glass was only imperfectly transparent to the chemically active rays, which were found in the most refrangible rays of the spectrum, heat rays being in the least refrangible portion, and light occupying the middle place. It had been found that rock crystal was one of the few substances which perfectly transmitted rays, those highly refrangible, which glass absorbs.

The Professor then showed that some kinds of light were without chemical action, the light from a mixed air-gas flame possessing scarcely any, while that from an ordinary gas flame did possess a little. The oxyhydrogen flame, while attended with intense heat, was endowed with very little chemical action. A prepared collodion plate exposed to this light for twenty seconds gave a very faint picture. But when the flame was thrown on lime, although the temperature was lower, the light had sufficient chemical activity to produce a strong picture, on a similarly prepared plate, exposed for the same time. In the case of the chemically acting rays, the intensity, number and position of the lines on the spectrum had been found to vary with the source of light. The most remarkable illustration of this was the different spectra produced by the electric spark of an induction coil between poles of different metals and projected upon a photographic plate.

The spectrum produced by the spark from silver poles, for example, was found to be three times the length of the whole of the solar spectrum transmitted by quartz. In order to obtain views of this invisible spectrum it was necessary to transmit the rays through a medium more transparent to chemical rays than glass, which it had been said, was opaque to the higher rays of this kind, and various experiments had been made to ascertain what substance allowed them to pass most freely. The results were shown in the following table of the—

Photographic Transparency of Solids.

Rock crystal 74	Sulphate of magnesia 62
Ice 74	Borax 62
Fluor spar 74	Bromide of potassium 48
Topaz 65	Thin glass 20
Rock salt 63	Mica 18
Iceland spar 63	Iodide of potassium ... 18
Diamond 62	Nitrate of potash ... 16

The above numbers being founded upon an arbitrary division of the spectrum.

The photographic transparency of liquids differed still more, as would be seen from the following diagram:—

Photographic Transparency of Liquids.

Water 74	Wood spirit 20
Alcohol 63	Acetic acid 16
Chloroform 26	Oil of Turpentine ... 8
Benzole 21	Bisulphide of Carbon 6

Various gases were also found to interfere with the transmissibility of these rays, as exhibited in the table of the—

Photographic Transparency of Gases.

Hydrogen 74	Benzole vapour 35
Nitrogen 74	Hydrochloric acid... .. 55
Oxygen... .. 74	Hydrobromic acid... .. 23
Carbonic acid ... 74	Hydriodic acid 15
Olefiant gas 66	Sulphurous acid 14
Marsh gas 63	Sulphuretted hydrogen 14
Coal gas 37	

The diamond and rock crystal allow the chemical rays to pass freely, but other substances, in which no difference of transparency can be discovered by the eye, considerably affect the transmission of these rays. Chloride of potassium allowed them to pass less freely; and nitrate of potash, and nitrates generally, offered still more obstruction. It was the same with fluids, and also with gases, as would be seen by a reference to the diagrams. It was remarkable, too, that solid bodies when dissolved or melted maintained exactly the same power as when in the solid state. The same was the case when they were converted into vapour, which showed that this power was part of the nature of the substance.

The lecturer then described the phenomenon of fluorescence, and showed that the chemical rays of the spectrum corresponded with the rays of fluorescence by taking a photograph in that part of the spectrum which, though otherwise invisible on the screen, lighted up a solution of resuline. He then showed that all metals give characteristic photographic spectra, some of them bearing a strong family resemblance to each other, as in the cases of iron, cobalt, and nickel, the last metal giving one of the longest spectra observed, and which extended to 190° of the scale. Arsenic, antimony, and tin showed as great differences in the invisible as visible part of the spectrum. The most interesting of the metals to study in this respect was magnesium, which opened a wide field for investigation. There were certain points of resemblance between the spectrum of magnesium and that of the sun, which lead to the supposition that this metal existed in the solar atmospheres. The comparison of the spectrum of magnesium with that of the sun led also to some important considerations as to the temperature of the sun. It was known that the higher the temperature the more refrangible were the rays of light emitted by a body. We have no conception of the temperature of the electric spark. The heat of the strongest wind furnace was estimated at 4,500° F., and that of the oxyhydrogen jet was supposed not to exceed 15,000° F., yet with neither of these could the same effects be produced as with the electric spark. The lines of the photographic spectrum of magnesium were not seen in photographs of the solar spectrum, and yet there was no doubt that this metal was present in the solar atmosphere. Kirchhoff had discovered that solids when heated give a continuous spectrum, but that bodies in the form of gas give rays of definite and limited refrangibility, each substance emitting light of definite property. He had also noticed that light from a luminous mass, by passing through ignited vapour which, *per se*, would give bright lines in the spectrum, became furrowed out in dark bands occupying exactly the same position in the spectrum as the bright lines. Now, ignited magnesium vapour emitted green rays which were absolutely identical with the group of fixed lines *b* in the solar spectrum, and it was therefore certain that magnesium was a constituent of the sun. It was, moreover, probable that the heat of the sun was inferior to that of the electric spark, inasmuch as it was insufficient to bring out the highly refrangible lines observed in photographs of the magnesium spectrum.

There were thirteen bodies known on earth which these researches lead us to suppose existed in the solar atmosphere. Nor are they limited merely to the sun. Fraunhofer had examined the spectra of several stars, and found that although they presented no similarity to that of the sun, nor to each other, yet that some general relationship between them was observable.

Mr. Huggins and the lecturer had recently been investi-

* Read at the Royal Institution, March 6.

gating this subject, and had obtained very perfect maps of the visible spectra of several stars. They had also obtained a photograph of the spectrum (which was exhibited) of Sirius. This star is 130,000,000,000 of miles distant, and the light which produced the photograph must have left it twenty-one years ago.

A photograph of the spectrum of Capella, which is three times further distant than Sirius, had also been obtained, the light to produce which, the lecturer said, must have left that star when the oldest in the room was a little boy. Professor Miller concluded an eloquent address, of which the above is a mere outline, by remarking how much these wonderful facts enlarged our ideas of the power of the great Author of the Universe, whose will "creates, sustains, and animates the whole."

A SHORT LESSON IN PHOTOGRAPHY.—No. 12.*

PRINTS, when removed from the printing frames, cannot be kept long either in the dark or between the leaves of a blank book, before decomposition spoils the surface. This decomposition is attributable to the presence of organic matter in contact with nitrate of silver, and is much more energetic on albumenized than on plain paper. Hence it is necessary as soon as the prints are either sufficiently numerous, or that no more prints are required, to proceed at once to the next steps in the routine of photographic printing.

Take either a pail or a tub, according to the circumstances of the case, depending on the number of prints to be manipulated with. These vessels must invariably be constructed of wood, and never of tin-plate or other metal. Be very particular on all occasions to see that they are perfectly clean from all extraneous matter, and especially from all sulphurizing substances, as sulphide of potassium or decomposed hyposulphite of soda, &c., whose presence would be very deleterious by producing stains that cannot afterwards be removed.

Fill the pail, &c., with rain water, and immerse the prints one by one. This operation has to be performed in the dark-room; keep the prints in agitation for about five minutes; now gather them all together, take them out, and place them for a moment aside in some convenient corner until the water is removed from the pail.

[Some artists, who conduct extensive establishments, first precipitate the nitrate of silver, now present in the water, by throwing into the pail about a teaspoonful, &c., of salt; the precipitate is allowed to subside, and the water is afterwards decanted and thrown away. When such an expedient as this is resorted to, it is better to have a tank into which all the silver washings can be thrown, and in which the chloride of silver can be precipitated as soon as a sufficient quantity of the water has accumulated; the supernatant water is afterwards allowed to flow off; and thus fresh supplies can be introduced, until finally there is formed at the bottom quite a considerable sediment of the chloride. This chloride is then removed, dried, and fused into pure silver.]

Fill the pail again with rain water, and wash the prints as before by continual agitation for the same length of time. Again withdraw the prints and pour the water into the tank; and, finally, with another pail-full of rain water wash the prints once more for about the same length of time. By this proceeding all the superfluous or undecomposed nitrate of silver is washed out from the prints; so that now there remain probably only the superfluous or undecomposed chloride of silver and albuminate of silver to be removed afterwards in the fixing bath. I say undecomposed chloride of silver, by which I mean that portion which, by reason of the dark parts of the negative, has not been acted upon by the light, and which would consequently spoil the prints if allowed to remain.

The parts that form the picture consist of chloride of silver made insoluble by light; this species of chloride, or subchloride, or oxychloride, is not thoroughly understood;

it has received new properties from the light, and might hence be denominated *actinate* of silver, or *actino-chloride* of silver. If any doubt should exist as to the successful completion of the washing of the prints, take one of them, immerse it in a basin-full of rain water, and, after the expiration of a few minutes, remove it from the water, and then add a particle of salt; if a milkiness is thereby produced, the washing has not been complete.

We will suppose, however, it has been complete and proceed. We find it to be an advantage before introducing the prints into the toning bath to pass them through hot water, whereby, probably, the albumen film becomes more effectually coagulated, or the toning by the heat is facilitated, and the time of toning shortened.

The toning bath consists essentially of a solution of chloride of gold made neutral with an alkali or an alkaline earth, as, for instance, with carbonate of soda or with carbonate of lime. Without this addition the gold would not only tone quickly, but bleach the prints quickly. Besides this alkali or earth some artists add an excess of either acetate of soda, phosphate of soda, or citrate of soda. Experience shows that these additions do not produce any very decided advantages if the chloride has been previously properly neutralized.

Again, other artists succeed most satisfactorily with a bath containing an admixture of nitrate of uranium. This bath once formed may be used over and over again, by simply adding from time to time fresh supplies of neutralized chloride of gold and nitrate of uranium.

TONING BATH.

Rain water	1 quart.
Nitrate of uranium neutralized with chalk	3 grains.
Acetate of soda	50 "
Chloride of gold neutralized with chalk	4 "
Chloride of lime	20 "
Alcohol	1 ounce.

By neutralizing the nitrate of uranium or the chloride of gold, by means of chalk, is meant, that to their separate solutions in half an ounce of water pulverized chalk is added until a piece of blue litmus paper first reddened by either solution is just restored to its original blue colour. As soon as this state occurs, the solutions are allowed to settle and poured separately, agitating all the while, into the water with which have already been mixed the other ingredients.

This bath will keep well, and it produces rich purple tones. It works much better, as do all toning baths, when the water is just lukewarm.

Into this bath, after it has been prepared a short time, introduce each print separately, and retain the prints in such a position as to preserve their picture surfaces in direct contact with the fluid, and not in contact with each other. Besides this, keep the prints in motion so as to obviate all abnormal or unequal action. As soon as the tone has become a sort of blue violet, take the prints out, wash them in hot water for a moment, and then immerse them in the fixing bath with the same precautions as in the toning bath, namely, so that their surfaces are not in intimate contact with one another.

FIXING BATH.

Rain water	1 quart
Hyposulphite of soda (to saturation) or about	8 ounces.
Alcohol	1 ounce.

The fixing bath operates much quicker if preserved at a lukewarm temperature. On the introduction of the prints into this bath the tone will change slightly at the beginning, but is afterwards partially restored. Considerable experience is required in the toning, so as to obtain the right shade, which, when fixed, will yield the most agreeable or a given colour *ad libitum*. If a rich sepia brown is required, the prints are not to be toned into the violet, but are to be taken out before they have arrived at this stage. If the hyposulphite of soda is genuine, and the method here prescribed has been strictly adhered to, the time required to restore the tone

* From *Humphrey's Journal*.

and remove all the soluble ingredients will seldom exceed four or five minutes, and is frequently much less than this.

The restoration of tone is in some measure a criterion by which to judge of the fixation; another criterion is the absence of all grey particles in the body of the paper in the transparent parts; if the tone has been thoroughly restored, and the whites are perfectly clean, the prints may be taken out and placed in a pail or tub of clean water, and washed by frequent renewal of the water; they are then allowed to remain in rain water for several hours, until every trace of the hyposulphite has been removed. We will, therefore, leave them in the water until to-morrow.

PHOTOGRAPHY AND BAD TASTE.*

EVERY new art, unfortunately, is sure to bring out a vast amount of bad taste on the part of its ignorant patrons. In these days everything is cheap—at least, most things are capable, so to speak, of being issued in cheap editions; and this tendency is not to be regretted. It is, indeed, one of the best results of civilization that the doors both of knowledge and pleasure are widely thrown open to the masses. The invention of printing first cheapened books; the development of science has cheapened the comforts and even the luxuries of life, so that a humble workman may now live in a manner far superior, in many respects, to the domesticities of a prince three hundred years ago. Art manufactures are making even our cottagers familiar with forms of beauty that will soon displace the monstrosities of former days; and schools of art are preparing the way for a still further extension of the principles of good taste. But it must be owned that the sudden development, in one particular direction, of a taste which as yet is but half informed, has led to much offensive vulgarity, and threatens, if it be not checked, to lower the standard of truthfulness in the popular mind. A large supply of anything, when combined with cheapness, as it is pretty sure to be, generally brings a large demand; and the demand, thus instantaneously and artificially stimulated, is certain to be attended by a considerable amount of ignorance and pretence. People require time to be educated up to the point of knowledge and refined perception. Those who supply them are often equally in want of correct ideas, and at any rate have an interest in producing that which the thousands can most readily appreciate; and thus the new art is for a time degraded. It was so with the invention of printing. For the first century or two after the great discovery of Faust, learned men were led to debate whether or not the printing-press had really proved a benefit to mankind; those who held the negative proposition basing their argument on the assertion that the labours of the compositor and pressman had given greater facilities than before existed for worthless scribblers to inflict their nonsense on the reading public. This evil, however, was one of those which always correct themselves in due time; and so it is with other mistakes of the same character. But in the meanwhile it is as well to see how we stand in regard to the æsthetic and intellectual uses of the most recent inventions.

Photography is an art peculiarly liable to be perverted to base uses. It is cheap (that is to say, when badly executed), and therefore appeals to a large class of uneducated people; it is singularly well adapted to minister to personal vanity, and to keep pace with the incidents of the day; and it is capable of producing, especially when combined with the stereoscope, effects which are more startling than artistic in their nature. All these facts form a perpetual incentive to the photographic manufacturers to lower what might otherwise be esteemed one of the fine arts, to the level of clap-trap, and sometimes to far worse uses. The Society for the Suppression of Vice can tell us something of one of the purposes to which photography is applied, and we know not

how many cartloads of immoral slides have been taken away from the sombre dens of Holywell-street and Wych-street. The police make a seizure of this kind every now and then; but there can be no doubt that the trade still flourishes, because a demand exists for these wretched incentives to evil. Then there are the photographs which may be seen even in respectable shop windows, and which just daily with questionable situations—just faintly suggest ideas of impropriety. Let us hope, however, that both these classes of photographic pictures appeal to a comparatively limited class of buyers. The majority of bad photographs are reprehensible on the ground of taste rather than of morality. Considered in this way, the detestable portraits, executed "in this style" for sixpence or a shilling, are really a nuisance, though the annoyance is one which cannot be abated by any other means than instilling into the mind of the community better notions of art. Nothing can be more natural or commendable than that John Brown should wish to possess a "correct likeness" of himself, to be presented to Mrs. Brown, or Jemima Higgins, his intended bride, or, perhaps, to his mother. But it is surely not a good thing that plain John Brown should be induced by the "artist" to assume the aspect and bearing of a brigand in broadcloth; or of a poet, Byronic and sentimental; or of a statesman, revolving in his anxious brain the fate of empires and of ministries, the consolidation of our power, and the liquidation of our National Debt. Nor is it at all desirable that when Jemima Higgins, in her turn, honours the "artist" with a sitting, she should be forced to take upon herself a Siddonian mien, as though just uttering the words, "Give me the daggers!" We say nothing of the cruelty inflicted on the general public by the wholesale exhibition of these monstrosities (framed and glazed) at the outer doors of the "studio;" or the annoyance of being pursued, for half a dozen yards along the pavement, by a loud-voiced, ruffianly-looking fellow, who bullying invites you to come in and be "done," and who, but for the fear of the police, would probably fight for the possession of your person, carry you into his den by main force, and "do" you in such a way as he might consider best suited to your particular style of physiognomy. These are matters of social arrangement, which, according to our English custom, must be left to settle themselves. But we must, on artistic grounds, protest against cheap photographic likenesses. It may be said that, if they satisfy their purchasers, and enable poor and humble people to gratify a vanity always harmless, and sometimes associated with affectionate thoughts of others, they do all which they pretend to do, and even answer a good end. This is very true as far as it goes; but if, by educating the perceptions of the lower orders to a better knowledge of what is truthful and reasonable, the more cultivated classes can save them from such nightmare phantasms of bad taste, it would surely be a desirable result. Vulgarity is not a necessary element of cheapness; it is only a necessary result of ignorance. The history of the last five-and-thirty years has shown what excellent literature may be published at a trifling price; and when good art is equally appreciated with good writing, art producers will find themselves obliged to seek for popular custom by a higher style of conception and execution than they at present display in the cheapest class of their works.

But it is not merely in the humblest stratum of society that bad taste in photography finds a ready market. It flourishes abundantly in the middle class. Every street passenger must have noted those portraits of royal personages with which the shop windows have recently abounded. Probably he has got a round dozen or so of them in his album. He is a loyal man, and wishes to have about him what he considers authentic likenesses of the sovereign, of the Prince and Princess of Wales, and of the other members of the family that reigns over us. Even if he does not care about such matters, his wife and daughters do, and the photographs must be had. Besides, they cost only a shilling each, so that for a guinea or two we might almost provide ourselves with illustrations of the whole *Almanac de*

* From the *London Review*.

Gotha. The photographic artists of Belgium know where their most numerous customers are to be found; and Brussels supplies England with the means of gratifying her curiosity in this respect. Paterfamilias buys a heap of shilling *cartes de visite*, and fancies that he has got the veritable effigies of royalty. He does not know that a vast number of these supposed portraits from the life are "cooked up" by foreign artists, whose main object is to make everything look pretty and sentimental. The result is often miserably false and bad. Here, for instance, we have lying before us a card which contains portraits of the Prince of Wales and the Princess Alexandra, issued several weeks before they were married. His Royal Highness sits in a chair, while the Princess stands over the back of the chair, with her two hands resting on his two shoulders. Pretty, is it not?—sentimental, sweet, and lover-like? Very—only not quite probable, or in the best taste. That a young lady may have stood, in that attitude of tender watching, at the chair of her future husband, is likely enough,—but she would never think of being photographed at so confiding a moment. The lover would certainly object to the artist "posing" his intended in any such way, and the lady herself would object to it with still greater vehemence. Can Paterfamilias possibly believe that the Prince and Princess allowed themselves to be shown after this fashion to the general gaze? Yet we believe that this particular *carte* has sold enormously, together with its companion, in which the position of the figures is reversed. Then there is another photograph, representing our widowed Queen contemplating a portrait of the Prince Consort, with the royal children grouped, in the manner of a tableau, around her; and there is another, still more theatrical, depicting the Queen and the young Princesses wreathing a bust of the departed with festoons of flowers. Within the last few days we have even been introduced in this way to the very death-bed of Prince Albert! The publisher thinks the photograph will be an "attractive, though sad" memorial; and he is probably well assured of his ground.

It is quite lamentable that any one should believe these fancy pictures to be photographs from life, or real scenes: yet we doubt not that they are generally so accepted.* People are actually so ignorant as to suppose that her Majesty, who has withdrawn herself from public life ever since her great affliction, would have permitted a photographer, for his trading purposes, thus to invade the very privacy of her grief.

The manufacture of these photographic impostures says little for the honesty of those who produce them; and it also suggests the existence of a great deal of bad taste in the English public, or these articles would not obtain here so large a sale as they do. But for the existence of that bad taste, the untruthfulness of such sketches would at once be detected. They are thought, especially by women, "pretty" and "interesting;" and the gross improbability of their composition goes for nothing. They are not beautiful as works of art; they are not truthful in any sense; but, like Packwood's razors, they are made to sell, and they *do* sell.

* There is, we regret to say, too much ground for the charges of bad taste imputed in this article, which, as a whole, is worthy of the serious consideration of photographers. The writer is, however, woefully misinformed with regard to facts. In reference, for instance, to the group of Her Majesty contemplating a portrait of the late Prince, and also his bust wreathed with flowers, the writer intimates his conviction that it is a spurious photographic manufacture; he is manifestly not aware of the fact, that, the photographer by whom it is issued possesses at least a quasi-official connection with the royal household, and sends this picture forth by the express permission of Her Majesty. We do not presume here to offer any expression of opinion on the question of taste, beyond remarking that the want of better information or of a more discriminating judgment, has caused this writer to be guilty of the bad taste evinced in criticizing the decisions of a royal lady on a subject which did not in any way necessarily challenge his attention. Taste is a question on which there may be differences of opinion; but there can be no doubt that the motive which induced Her Majesty to thus admit her people, to share, as it were, the privacy or domesticity of her grief, is one which should meet with tender sympathy. The writer is also manifestly in error in his allusions to M. Ghemar's pictures, of the genuineness of which there cannot be a doubt, that artist having been honoured with sittings, not only from the Prince of Wales and his intended bride, but by the Queen and several other members of the Royal family.—ED. PHOTO. NEWS.

The Belgian artists know our weakness and find their own strength in it. A people possessing a widely diffused perception of what is artistic, would not be bamboozled by such false pretences; the power of apprehending the highest forms of art being one with an instinctive sense of verisimilitude. The strange part of the business is that we English, despite our dullness in matters of art, should not perceive, by the mere strength of our honest love of matter of fact, the absurdity that is palmed off on us. But when the matter of fact man takes to art in any form, he is generally best pleased with that which is false. The artistic world being an utterly strange world to him, he makes the mistake of supposing that untruthfulness is the law of its existence. He demands "effect" above all things, something that will give him a sensation beyond his ordinary round of ideas; and whatever does this commands his enthusiasm and his patronage.

PHOTOGRAPHIC PIRACY OF ENGRAVINGS.

SHERIFFS' COURT, *Red Lion Square, April 2.*

(*Before Mr. Under-Sheriff BURCHELL and a Jury.*)

GAMBART v. SCLATER.

THIS was an action brought in the Court of Common Pleas under the 17th George III., chap. 57, and the 8th George IV., chap. 113, for an infringement of the copyright of the engraving "The Light of the World." The damages were laid at £500, and the defendant, who resided at Canterbury, having allowed judgment to go by default, a writ of inquiry was executed to assess the amount to be awarded.

Mr. Biron appeared as counsel for the plaintiff; the defendant was not represented.

In opening the case to the jury, the learned counsel stated that the plaintiff, Mr. Earnest Gambart, was the well-known printseller in Pall Mall, and was a great promoter of art. He had published engravings of Rosa Bonheur's "Horse Fair," Frith's "Dorby Day," and Holman Hunt's "Finding the Saviour in the Temple," and "The Light of the World," by the same painter. It was in respect of the last picture that the present action was brought. Mr. Gambart had expended large sums on the works, and they had been photographed, and sold at very small sums—from 1s. to 10s.—when the price charged was from two guineas to ten guineas. Mr. Gambart had sustained a very serious loss and could not account for the decrease in the sale of the "Light of the World," which had been one of his most successful productions, until he discovered that it had been copied and sold by such persons as the defendant in country places. The defendant was a shop-keeper at Canterbury, and boasted, when called upon, that he had sold a considerable number. The only remedy for Mr. Gambart was to bring the present action, and unless the jury gave substantial damages the great works of art would be pirated, and publishers, unless protected, would not embark in any enterprize on the subject, and the public would be the losers.

A traveller named Lefevro proved the purchase of a photographed copy of "The Horse Fair" and "The Light of the World," at the defendant's shop at Canterbury, for a few shillings; and he told him he had sold a great many of them.

Mr. Gambart stated that he had given Mr. Holman Hunt 200 guineas for the privilege of engraving the picture of "The Light of the World." He had paid the engraver over 300 guineas as his fee, and £130 to the owner of the picture for allowing the engraving to be made. With other expenses, including canvassing and advertisements, he had expended upwards of £2,000 in bringing out the print. The print had been published about three years ago, but he had been five years about it. The print was his most successful production, and he realized the first year about £10,000. He discovered that about two years ago there was a great falling off, which was not to be expected from the success it had achieved, and he ascertained that, with others of his productions, it had been photographed, and sold for a few shillings. He had sustained a considerable loss. His prices were from one to eight guineas. The manner in which photography had been used to copy his productions was a serious injury to him; and on one occasion, when he consulted Sir Richard Bethell (the Lord Chancellor) on the subject he preferred the photographed copy.

Mr. Under-Sheriff Burchell remarked that some one must get the advantage. He supposed it was the public.

Mr. Gambart said he was greatly injured. Photographers could produce copies for 1½d.

The learned Under-Sheriff had no doubt there was "great light in the world," but whether it was the "light of the world" was another and a very different question.

Mr. Graves, printseller, of Pall Mall, was called to prove the loss Mr. Gambart was likely to sustain by having his prints copied.

Mr. Under-Sheriff Burchell could not see how the question could be asked. The defendant, he was sorry, was not represented, and he could not see how it could be proved against him what injury Mr. Gambart had or was likely to sustain. The question was, what damages Mr. Gambart could recover against the defendant, and not the injury likely to accrue to Mr. Gambart by photographing his production.

Mr. Graves said that unless printsellers were protected it would lead to the destruction of the trade, as no one would give a large price for permission to engrave a picture.

A resident at Canterbury, named Ginger, who had acted as agent for the sale of the print, stated that he had obtained subscribers to the amount of 70 guineas, and after the defendant sold copies by photography the sale fell off. He called on the defendant, and he abused him. He was now selling the copies.

Mr. Under-Sheriff Burchell thought the jury should know what occupation the defendant followed, as it would assist them in estimating the damages to be awarded.

It was proved that he was a shopkeeper and a maker of picture-frames.

The learned Under-Sheriff, in placing the case before the jury, told them that the only question for their consideration was the amount of damages to be awarded for the infringement of the copyright, as, by allowing judgment to go by default, defendant had admitted that the plaintiff had a right of action against him. The question was, no doubt, a difficult one, and the defendant had not thought proper to appear and offer any explanation as to the course of conduct he had pursued. The plaintiff had stated the sum he had paid for the work of art in question, and also that the sale had fallen off in consequence of the photographed copies being sold. He had not allowed him to be asked what loss he was likely to sustain from such conduct, because it could not be fairly submitted against the defendant. He had not sat in that Court so many years without knowing that a man could not be permitted to estimate the damage he was likely to sustain. He would further say that the jury were not there to punish the defendant, but merely to compensate the plaintiff, so far as he was concerned, for the injury of which he complained, as against the particular individual.

The jury consulted in the box and wished to retire. After a short consultation they returned into Court with an assessment of 100*l.* damages.—*Times.*

Proceedings of Societies.

LONDON PHOTOGRAPHIC SOCIETY.

THE usual monthly meeting of the London Photographic Society was held in King's College, on the evening of Tuesday, April 7th, Mr. P. LE NEVE FOSTER, M.A., in the chair.

The minutes of a previous meeting having been read and confirmed,

THE CHAIRMAN called attention to some views of India which he thought were superior to anything he had seen done in that country. They were produced by Mr. Elphinstone Underwood, the President of the Madras Photographic Society, a gentleman whose name would be submitted to the meeting for election as an honorary member of the body.

A revolving pillar stereoscope, with some five transparencies of Japan, &c. was exhibited by Messrs. Negretti and Zambra.

The following gentlemen were elected members of the Society:—Messrs. J. R. Johnson, W. Elphinstone Underwood, and Thomas Brooks.

It was announced that the two promised papers, one by Mr. Heath and the other by Mr. Johnson, would not be read; these gentlemen being unable to be ready in time.

Mr. SHADBOLT produced three specimens of panoramic pic-

tures taken on a flat plate with a common lens. He said that the fact that they had been produced some time ago did not detract from the merit of Mr. Johnson's invention, as no account of those he now produced had been published; they were merely placed in his hands as a record of the fact that such a thing had been done. The first picture to which he would call attention was the interior of a room, and if anything would show forcibly the fallacy of circular, or panoramic photographs, this would, as it gave the four sides of a room, and a little over, on one flat plane. Another picture was a landscape view, and in it a straight road was sadly distorted. Apart from these specimens, he held in his hands the specification of a patent dated October 6th, 1857, which seemed to him to embrace, not only all that had been done, but all that could be done in that direction. The patent was obtained by Mr. Brooman, and the invention was stated to be a communication from M. Garella.

THE CHAIRMAN referred to Marten's panoramic camera for daguerreotype plates.

Mr. SHADBOLT remarked that M. Marten's camera was for producing panoramic pictures on a curved surface, but this patent was like Mr. Johnson's, for producing them on a plane surface. So far as a patent was concerned for the latter gentleman's invention, it was out of the question altogether. The principle of M. Garella's was for a motion of the plate in proper ratio to another motion of the lens and camera, and he presumed Mr. Johnson's was of a similar character, but probably simplified and improved.

THE SECRETARY read a communication from M. Rolloy of Paris, recommending his varnish, which was stated to consist chiefly of white lac in alcohol, prepared in some peculiar manner.

Mr. JOHNSON wished to say a few words in reply to Mr. Shadbolt. He was perfectly aware of the various attempts which had previously been made to produce panoramic pictures on flat plates. M. Garella had attempted it; Mr. Sutton had attempted it before he invented his lens for curved plates; and others had attempted. But what others had attempted and failed in achieving, he had succeeded in doing. He did not claim any novelty in principle; all he claimed was the difference between success and failure. The specimens Mr. Shadbolt had brought that evening were striking illustrations of the former failures, and were very unsuccessful indeed, showing that the motion applied was altogether inadequate to produce the end. Regarding the alleged distortion, the result was, of course, in what was termed panoramic projection, in which parallels vanish in curves; but if the eye, in examining the picture, were placed at the proper point of sight, all appeared right.

Mr. DEBENHAM wished to say a few words in answer to a communication from Mr. Penny, which had appeared in the PHOTOGRAPHIC NEWS. He had hoped that Mr. Simpson would have brought forward the specimens that evening, together with some promised results of his own, but he understood from that gentleman that he was suffering from some indisposition, and would not therefore bring the matter forward.

Mr. WHARTON SIMPSON said if Mr. Debenham would allow him he would willingly place the specimens before the meeting, but he was not then prepared to enter into any comment, beyond pointing out that from the specimens of Mr. Penny in his hands an undoubted accession of sensitiveness appeared to have been obtained.

Mr. DEBENHAM resumed: he thought he could easily explain the discrepancy of experience. Mr. Penny's bath was stated to be acid with nitric acid, and therefore not in the best condition for sensitive results. With a bath in such a state, it was possible that fuming might to some extent have connected it, and hence the improved results described. He should not enter into any comment upon what he conceived to be the unnecessarily personal remarks upon himself.

Dr. WRIGHT, recurring to the communication of M. Rolloy, thought that although it partook more of the character of an advertisement than anything else, it might have originated an interesting discussion upon an important subject. He referred to one or two singular and annoying circumstances connected with varnish occurring in his own experience, one of which was a portion of the image being dissolved off by Schönée varnish. He attributed this to the plate being too dry before immersion in the bath, and so causing the image to be entirely superficial, instead of in the film. He also mentioned the value of a glass coated with spirit varnish chilled, as a substitute for a broken ground glass.

Mr. J. W. OSBORNE said, that he had used amber varnish in hot climates, and although the plates had been exposed to a temperature of 130°, he had never known the varnish stick to the paper, as alleged by M. Rolloy. In his own particular work he used a solution of gum arabic applied before drying the plate, which answered every purpose so long as the plate was kept dry. This he managed by using tin-plate boxes instead of those made of wood. He thought the tin boxes had many advantages which made them superior to wood; they gave more space for storage, and preserved the plates much better from damp.

Dr. DIAMOND said other causes would sometimes make the varnish dissolve off the image, besides the plate being too dry before going into the bath. It had recently occurred in his hands, from the use of a horny collodion, which kept the image on the surface instead of permitting it to permeate the film properly. With another sample of collodion, treated in all respects in the same way, the image did not dissolve.

Mr. SHADBOLT had not heard any suggestion from previous speakers as to the real cause of the varnish dissolving the image. It was well known that some samples of pyroxyline were to some extent soluble in alcohol, and as the Sehnée varnish was made with strong spirit it would dissolve a film constituted of such cotton; but the dissolving had nothing whatever to do with the image being merely on the surface.

Dr. DIAMOND said that in the case to which he referred the film was not dissolved, but was there clean and horny after the image was dissolved off the surface. A sample of the collodion was at Mr. Shadbolt's service if he wished to convince himself.

Dr. WRIGHT said in his negatives the film was not dissolved, but remained quite perfect, the image only was removed by the varnish.

Mr. ELPHINSTONE UNDERWOOD referred to the difficulties of obtaining good varnish suitable for India, and also to the difficulty of obtaining anything but hard negatives there.

After some further conversation it was announced that a number of the prints of the late Prince Consort were ready and would be distributed by ballot. It was also announced that at the next meeting Mr. Richards would exhibit some apparatus by M. Bertsch, and that papers by Mr. Johnson and by Mr. England would be read. Also that at the June meeting Mr. Brookes would read a paper "On the Latent Properties of the Blue Ray in regard to Iodide and Chloride of Silver."

The meeting then adjourned.

THE AMERICAN PHOTOGRAPHICAL SOCIETY.*

The Society held its regular meeting for March, on Monday 10th inst., at the University. President JOHN W. DRAPER in the chair.

Collodion Films.

Mr. F. F. THOMPSON exhibited some collodion films of negatives taken in the Imperial print works at Vienna. The films were detached from the glass, and sent to the president of the Photographic Society of Philadelphia, who had sent them here for exhibition, as an interchange of friendship between the two societies. By daylight the film is very yellow and dull; it prints about twice as slow as a glass negative. The gelatine which is used with the collodion seems to destroy the brilliancy almost entirely.

Professor SEELY said that in galleries where they sometimes have a ton of negatives, a practicable process of removing the film would be very useful. Gutta-percha had been suggested for this purpose. There is no difficulty in removing the film with gelatine, and probably would be none with a gutta-percha solution in benzole or chloroform. Moisture would probably have an injurious effect upon gelatino, which would be an objection to its use for this purpose.

Col. PIKE stated that he had frequently removed collodion films by pouring over the plate a weak solution of cyanide of potassium, which starts the film immediately.

Mr. THOMPSON remarked that these films were very convenient for packing; but considered this no compensation for the want of brilliancy in the prints.

Professor SEELY called attention to the fact that these films are so sensitive to moisture that the moisture of the hand or of the breath makes them move, curling like the leaves of the "Chinese love-plant."

The PRESIDENT remarked that dry shavings, or horn, or gelatine, are affected in the same manner.

Cameras for Travelling.

Mr. THOMPSON exhibited and explained a camera box, containing all the apparatus, excepting the tripod, and a dozen prepared plates eight by ten inches, the whole weighing no more than a pail of water. He exhibited also a sample of the work from a plate which had been prepared more than two years before the picture was taken upon it. He said that the box he had exhibited and which was invented by Mr. Hughes, of England, weighed but half as much as Mr. Stock's box. He had carried it twenty-five miles in a day; and he had never had any trouble with it in practical operation. This picture was taken from one of Norris's prepared plates, sent to this country two years ago, having then been prepared several months. These were gelatine plates; but tannin plates, well packed, will keep equally well.

Col. PIKE said that to prepare plates for keeping, two grains of gallic acid should be put into fifteen grains of tannin; and the plates should be washed well, and the solution flowed over them; and then they would keep any number of years, if kept in a dry place. The tannin should never be used a second time. There seems to be some chemical change in it, unfitting it for repeated use. He objected to the plan of washing plates under a tap. It was better to immerse them in a dish of clean water, moving it about gently.

Mr. MASON: Does the acid make any difference in the sensitiveness of the plate?

Col. PIKE: Not at all.

The Effect of Washing Plates.

The PRESIDENT called up the subject selected for this evening, being "The Effect of Washing Plates," and said the operation referred to, in selecting this subject, was this:—In the wet process, after having immersed the plate in the nitrate bath, it is thoroughly washed to remove the nitrate of silver it contains; it is then exposed in the camera; and in the subsequent development it must receive a sufficient quantity of nitrate of silver to replace that which has been washed away. The advantages which seem to follow from this manipulation are the extreme purity and cleanliness of the result. In the washed plates, we never see holes, specks, black dots, or anything of that kind. The surface is perfectly pure and clear. Nor do we ever see those white silvery stains that come up chiefly from the lower part of the shield. Upon such a plate, developed and dried, the collodion film is perfectly glassy, looking as transparent as the glass itself. Another advantage is that the state of the bath, as regards its said condition, becomes comparatively unimportant. An acid bath seems to work nearly as well as one perfectly neutral. The drawback upon the operation is that it diminishes the sensitiveness of the plate. But where great speed is not essential, he regarded the process as a considerable improvement.

Col. PIKE stated that, two years ago, having occasion to work the wet process, he found upon developing his pictures that they had streaks across the plate. After various experiments, for three months, he had determined to wash the plates thoroughly; he then obtained good pictures. And to this day, he continued the practice of washing the plates; although in gallery work it diminishes their sensitiveness so much as to be impracticable. In developing these washed plates, by using a few drops of pyrogallic acid, he could get any required intensity.

The PRESIDENT said that his son, Dr. Henry Draper, who had occupied himself a good deal in astronomical photography, had found that the washing operation very much facilitated his operations. He could prepare quite a number of plates in the beginning of an evening, and could keep them in saucers of water for several hours, if required. In taking lunar photographs, for instance, clouds are apt to interfere; but the plate is all ready for use at any moment. The diminution of the sensitiveness of the plates may not be so great as some imagine. From the accounts given by Mr. De la Rue and other foreign gentlemen who have taken lunar photographs, making due allowances for the optical effects of the instruments used, it appears that a washed plate will give a representation of the surface of the moon very nearly as quickly as those not washed.

Dr. HENRY DRAPER remarked that the difference seemed to a great extent to be that the washed plates require much more time for their development. The picture will not flash out, as from a plate not washed. But a developer can be placed upon

* Abridged from the *American Journal of Photography*.

the plate for twenty minutes or more, and the picture growing better all the while; the clear parts remaining perfectly clear without any fogging. And although the density of the black portions may not be so great, yet the absolute purity of the light portions may cause the picture to be quite as intense as from the other process.

Mr. BURGESS asked for a more detailed description of the process.

Dr. HENRY DRAPER: I use for celestial photography any good collodion immersed in a forty grain (acid or neutral) bath. The plate, being washed, is exposed. On removal from the camera, it is again put under the tap. Then a pyrogallic and nitrate of silver solution is poured on. It is composed of two drops each of the following, in two drachms of water:—1st. Pyrogallic acid, 72 grains; alcohol, 1 ounce; 2nd. Nitrate of silver, 20 grains; citric acid, 50 grains; water, 1 ounce. The development is quite slow, occupying sometimes twenty minutes. Doubtless too the exposure is longer. But there is no comparison between the results obtained in this way and those by the usual wet method. The former are much purer and clearer in the transparent parts, and there is no trace of fogging. They will bear much more subsequent magnifying.

The PRESIDENT: When these pictures are properly developed, they are so black that you can barely see the sun through the darkest, densest parts. With proper development, you will have as dark a picture as you can get with any photographic process.

Mr. BURGESS suggested that this process would be valuable in copying engravings, or in copying photographs.

Col. PIKE said that Professor Seely had suggested to him some months ago to try an experiment of using the ammonia nitrate of silver for pictures exposed the fractional part of a second. He had tried the experiment and sometimes with such success that he would recommend others taking instantaneous pictures to try it. It would be excellent in the galleries, for taking children.

Professor SEELY said that the process of washing the plates had a great deal of novelty in it; but it reminded him of some experiments he had made three years ago. He had then been troubled with a sandy or mottled surface upon negatives. We now know that this arises from impurities in the nitrate bath. In order to demonstrate this, he had proposed to dip the plate in the bath, and after sensitising it, to wash it off and expose it in the camera. There were two trials, the exposure being about one-third longer, and the result was a very clean picture, without any signs of mottling. The development also, as he expected, was slower. The experiment of washing the plates was tried for that purpose only, and there it rested. These suggestions now came with a great deal of novelty, and something useful may come from them. The difficulties as to the development may be easily overcome. Another advantage in this process is the saving of silver which may be effected by it.

The PRESIDENT remarked that even when the exposure had been too short, even the most delicate parts of the picture are all perfectly there; it is only a tax upon patience in the development to bring them out. But we may have a dozen plates developing at once if we please.

Professor SEELY: Has a trial been made of insufficiently washing the plates, so as to leave a small quantity of silver upon them?

Dr. HENRY DRAPER: No sir; the silver was always washed off as clean as we could. The difficulties that exist in photographing with a Newtonian reflector, bringing the plate nearer the open window, instead of the ordinary refracting telescope, where the plate is at the end farthest from the window, made it necessary that we should wash the plate as completely as we could.

Professor SEELY suggested pouring over the film, after washing, a solution of ten grains of nitrate of silver, which would perhaps unite the advantages of washing with the advantage of sensitiveness.

Camphor Crystals.

Mr. TILLMAN referred to a paper on the subject of camphor crystals, and experiments which the President (Dr. Draper) had made with them.

The PRESIDENT: These camphor experiments always present themselves pleasantly to me as being the first thing that drew my attention towards photography and the action of light upon various substances. I think it was in 1828, while attending

lectures as a student in the University of London, a large glass globe containing camphor was introduced, and upon the sides towards the window there were large and magnificent crystals; and the observation was made that the crystallization was due to the influence of the light, but that up to that time nothing was known respecting the manner in which it took place. That excited my curiosity a good deal, and I tried the experiment for myself. I soon found that the operation would be vastly improved by exhausting the air from the vessel previous to the exposure. Instead of taking several days, the crystallization would take place in an hour. After a great many experiments, I ascertained that a piece of tin foil upon the glass would protect the glass from crystals behind the foil and for half an inch from it. I finally came to the conclusion that the old theory was incorrect; that the crystallization was not caused by the light, but by the heat. The side of the vessel nearest the sky becomes the coldest, and the camphor crystallizes upon it simply by virtue of its being a cold surface. Anything placed before it to obstruct radiation, will prevent the formation of the crystals. That was the explanation I gave of that fact and others connected with it more than twenty years ago. The same explanation has been given within a few weeks, which led to a reclamation upon my part.

The Actinic Spectrum.

Professor JOY translated an extract from the supplement to No. 232 of the *Allgemeine Zeitung*, with reference to experiments by Steinheil and Albert, in which they state that the yellow, green, and blue portions of the spectrum cannot be photographed.

The PRESIDENT said that their experiments must have been very badly made, for he had taken photographs of the solar spectrum from the extreme red to the extreme violet, and extending as much farther beyond the visible spectrum. He had sent such a photograph to Sir John Herschel, in 1842, a long account of which was published in the *Philosophical Magazine* in 1843 with a steel engraving. There were probably as many new lines in that spectrum as in all of the spectrum that had been examined before.

Professor JOY remarked that he read the extract to give the president an opportunity to reclaim that discovery also. Mr. Rutherford had also photographed the whole spectrum.

Correspondence.

FOREIGN SCIENCE.

[FROM OUR SPECIAL CORRESPONDENT.]

Paris, April 8th, 1863.

At the last meeting of our Photographic Society, M. Ch. Vinois suggested a mode of taking a good view of a building or other object when, from the contracted space around it, it is difficult to find a place for the camera and obtain a good picture. This inconvenience he proposes to remedy by placing a mirror before the object to be photographed, and then pointing the camera to the reflection of the object in it instead of to the object itself. By this means double the ordinary field of observation is obtained; it is true the image is reversed, but that defect can be easily remedied. He claims that this method presents many advantages in taking portraits. The mirror is supported on a painter's easel.

M. Bertsch objected that every mirror reflects two images of an object; one from the surface of the glass, the other from the surface of the mercury with which it is silvered; and that, moreover, the two surfaces of a plate of glass were rarely parallel, so that the two images reflected would scarcely coincide. To this, M. L'Abbé Moigno and M. Lemaitre replied that they had seen mirrors placed opposite a model to augment the distance.

M. Bertsch admitted that the thing was possible by arranging the mirror at 45° from the model in an atelier, for example, in taking portraits; but in proceeding to take views of public buildings no mirror could increase the angle embraced by the objective, consequently, we cannot accomplish the aim proposed by M. Vinois.

M. Couvreur addressed a communication on the danger presented, in certain modes of treating deteriorated silver baths, he says: "I am accustomed, when my positive silver bath is blackened by organic matters, instead of treating it with a chloride or a phosphate which, it is true, clarify it, but which at the same time weaken it—to evaporate it to dryness; and adding nitric acid, afterwards fuse it. The nitric acid and nitrate of silver entirely destroy the organic matters, and a little silver is found reduced. As in chloridizing my paper I exclusively employ chloride of ammonium, the nitrate of ammonia produced is volatilized, leaving me a nitrate of silver only very slightly coloured grey by the reduced silver.

"Next adding some drops of nitric acid, and evaporating it anew to dryness, and also gently fusing it, a very white nitrate of silver remains, which gives me a pure nitrate of silver bath without any loss of silver.

"I do not pretend that the process I employ is a new one, and only because I think many persons may employ it that I think it useful to caution those who are unaccustomed to chemical reactions of the danger they incur in adopting this method, as well as that indicated by M. L'Abbé Laborde, who advises the addition to the nitrate bath of a given quantity of alcohol, with the view of rendering the impregnation of the paper more rapid and complete.

"I have tried this addition, and find that it gives good results. But after making use of this bath, I afterwards evaporated it, and added the nitric acid as advised above: my bath was rather strong, containing 20 per cent. of nitrate of silver; when the liquid was warmed, I obtained, as may be easily proved, some fulminate of silver."

We can, certainly, avoid this objectionable result by previously diluting the bath with as much water as will reduce its strength to 8 or 10 per cent. of nitrate of silver at the most, and taking care not to add the nitric acid until all odour of alcohol has disappeared.

M. Kessler has invented a new apparatus for evaporation and distillation, to which he gives the name of *erorateur*. It is adapted for chemical purposes, and will be found useful to photographers, either for distilling water or for evaporation. M. Davanne, who presented the apparatus to the Photographic Society, stated that he had, during several days, employed it in the distillation of water, alcohol, ether, in the treatment of old collodion, and in the evaporation of the mother waters of the double sulphate of iron and ammonia, and in all cases had obtained satisfactory results.

For distilling water, by heating rapidly, and abundantly cooling the upper plate, he was able, with the small copper apparatus, to obtain as much as three litres ($5\frac{1}{2}$ pints) of water per hour, which, if not absolutely pure, was equal to that furnished by an ordinary alembic. If the water is required in an absolutely pure state, we must collect only the water of emanation, that is to say, evaporated without ebullition. In making use of the three plates the distillation of alcohol proceeds rapidly, without its being necessary to lute the edges. If it be desired to distil ether, the evaporation is just as simple, only the precaution must be taken to cover the joints with a strip of glued paper.

The double *erorateur* serves also for distilling old collodions; the lower basin serves as a *bain-marie*; the liquids to be distilled are placed in the middle one, and a continuous current of cold water cools the upper plate. By a well managed distillation we can easily separate, first the ether, and then the alcohol; the gun cotton and the iodides remain in the basin. We must, however, before making the distillation, deprive the collodions of their colour by the addition of a very small quantity of caustic potassa, to prevent the volatilization of the iodine, which would colour the distilled products. This operation is preferably made in a porcelain *erorateur*, for the residue of the collodions destroy the tinning of the copper apparatus.

The porcelain apparatus must also be employed whenever we desire to concentrate solutions of photographic salts in order to obtain crystals.

The various experiments made with the *erorateur* lead M. Davanne to conclude that this apparatus, on account of its small bulk, may prove very serviceable to travelling photographers: it is equally useful to photographers who desire to purify their chemicals.

M. E. Renet proposes to substitute tartaric acid for formic acid, in the developing bath of sulphate of iron; his formula is—

Sulphate of iron ... 6 parts, by volume, of a solution at 9 per cent.
Tartaric acid ... 4 parts, by volume, of a solution at 4 per cent.

These proportions are not arbitrary, the author, for want of leisure, has not yet determined the best proportion. His sole object is to call the attention of photographers to the good results obtained by the addition of tartaric acid to sulphate of iron.

The mixture of the two solutions gives a compound of the colour of olive oil.

The conditions under which M. Renet operated are as follows: his collodion is a mixture of numerous old collodions of different formulae, containing various bromides and iodides; a special collodion is not indispensable. The plate is sensitized in a bath of 7 per cent. nitrate, immersed in it 20 or 30 seconds. Exposed and developed in the solution of iron and tartaric acid. This developer does not act upon the latent image immediately. It begins to appear after three or four seconds, and gradually acquires the desired intensity if the exposure has been sufficient, and without the necessity for intensifying. The half-tones have a delicacy which neither sulphate of iron nor pyrogallie acid employed alone can give. The general tint of the negative, after fixing, is an intense blue black.

THE GLOBE AND TRIPLE LENS.

DEAR SIR,—In your report of the proceedings of the North London Photographic Association, of Wednesday, March 18th, 1863, you state that Mr. Harrison's globe lens possesses an advantage over my new actinic triplet.

Allow me to inform you that Mr. Dawson (Professor of Photography at King's College) and myself made several comparative experiments with the two lenses in question, and the conclusion arrived at was, that my actinic triplet possessed this decided advantage over the globe lens, that its definition was incomparably superior.

Doubtless, sir, you have seen the globe lens, and, from your intimate knowledge of the effects produced by the various forms of lenses, you will see that the globe lens possesses positive spherical aberration in a very marked degree, so much so, indeed, as to render necessary the use of a remarkably small stop in order that this aberration may be reduced to a minimum.

I may state that Mr. Dawson has, at King's College, several negatives which fully confirm the fact that my actinic triplet produces the most brilliant and best defined results.

Permit me to say, in conclusion, I hope you will not regard this as an attack on the globe lens, my only object being the rectification of an erroneous statement in which I feel personally interested—I remain, dear sir, yours truly,

THOMAS ROSS.

March 30, 1863.

[On a reference to the report in question, it will be seen that we expressed no personal opinion of the globe lens, but simply recorded Mr. Dawson's remarks thereon. The alleged advantage was not an advantage *per se*, but one merely due to its longer focus. We have already, in these pages, stated that the globe lens possesses considerable spherical aberration, and does not give even tolerable definition without a small stop. It is not, in our opinion, comparable in general qualities to the triple.—ED.]

To Correspondents.

YELLOW GLASS.—Two samples of glass from "S. W. B.," and from "J. M.," have been forwarded, with a request that we will report as to their photographic value. The sample from "S. W. B." is of a dark orange body coloured glass, and, to a casual observer, would appear quite dark enough for glazing a dark room with. The spectroscopic, however, reveals that some chemically-acting rays of light struggle through, although in very small quantity. The specimen from "J. M." is flashed glass, rather darker than the former sample, and quite opaque to the chemical rays of light.

P. M.—Cyanide of potassium will readily remove a fresh silver stain; but if it be old, or, indeed, in all cases, it is well to convert the silver first into an iodide, as it is then more soluble, and more easily removed. The following mixture is useful to keep on hand:—

Spirits of wine	1 ounce
Iodine	20 grains
Nitric acid	20 drops
Hydrochloric acid	20 "

This, applied to any silver stain, and followed by cyanide of potassium or hyposulphite of soda, at once removes all traces. Apply the first solution to the stained linen by means of a camel's-hair pencil, the black stain will become yellow; now apply a solution of hypo or cyanide, and the stain will quickly disappear. Then rinse the place thoroughly with water.

D. W.—A portrait lens may be used for landscapes, but if objects on many different planes are to be defined, it will require stopping down considerably. 2. The value of a negative depends upon so many things that no definite, or satisfactory, answer can be given.

TYRO.—A floating scum of metallic silver formed during development, or a quick decomposition of the developer, throwing down the silver in a dark powdery form, may arise from several causes; such as the presence of some impurity in the nitrate bath, too little acid in the developer, under-exposure and protracted development, or the presence of some white light in the dark room.—2. Same as above. 3. A rusty appearance at the edge of the plate is most probably fog from imperfectly cleaned glasses. 4. When Prussian blue is formed on your plate it is because the iron was not sufficiently washed away before applying the cyanide. A porous and absorbent collodion requires much more carefully washing to remove each solution than a horny one. 5. Brilliancy in the negative depends upon the harmonious co-operation of many causes too lengthy to detail here; read a series of articles entitled "Iron Negatives and Brilliant Prints," which appeared in the Fifth Volume of the PHOTOGRAPHIC NEWS. From what you state, either your bath is out of order, or you develop too long.

6. It is very difficult indeed to distinguish at all times between the fogging caused by impure chemicals, and that by diffused light; nevertheless, as a rule, the surface deposit indicates that the chemicals are at fault.

R. (GLAER.)—It is quite unimportant whether your ground glass be thick or thin, as the image falls on the anterior surface. In the choice of a lens we prefer maker No. 2. It is necessary to tone in a dark room, as the prints would, of course, be injured by exposure to white light; but it is not important that the room be as free from white light as that for developing negatives. The two modes of spelling Voigtlander and Son, both refer to the same firm.

A. M.—There are various modes of obtaining metallic silver from the chloride, but perhaps the simplest is to reduce by heat in crucible by the aid of a flux. First carefully wash the chloride to remove all impurities, then dry and add twice its weight of a mixture of carbonates of potash and soda, or of carbonate of soda and of borax, place in a crucible, and apply a bright red heat for about an hour.

H. C. M.—Your question as to the best paper for enlarged pictures is a very indefinite one, as you do not state what mode of enlarging is to be employed. If you mean prints from enlarged negatives any paper which gives good results for small negatives will do; if to enlarge by means of the solar camera, printing out, then any good paper for other purposes will do; but if you mean enlarging and developing the print, then a paper especially suited to the results you require should be used. Towgood's paper gives generally the most vigorous, Turner's more half-tone; the Saxe and Rive papers more half-tone still. Some operators prefer drawing paper, as being less liable to tear in the washing. As regards the photographic result of any of these papers much will depend on the salt employed in the first preparation.

VEADANT.—You cannot do better than you propose, nor can you secure greater cheapness without sacrifice of quality. 2. No stereo lens will not cover anything like a $7\frac{1}{2}$ by $4\frac{1}{2}$ plate; using the front lens of the combination will give you a little larger field, but not to cover the plate in question. 3. The simplest shutter for your purpose is the flap shutter made by Dallmeyer. 4. Mr. Robison, of Leamington, is a professional photographer.

SR DEXIS.—A good bromo-iodized collodion, without any addition to it, is suitable for taking interiors. 2. There is no remedy for a collodion which has too much water, except mixing it off with a better sample. Keeping out of the bath until it is well set, will decrease its tendency to reticulate. Exposing long enough, so as not to need to force the development or intensifying, will also decrease that tendency.

AN AMATEUR.—When you refer to the albumen going into streaks, we presume you are referring to the process of albumenizing paper, although you do not say so. Streaks in albumenizing will occur from many causes, the most prominent of which is unskilful manipulation. The albumen not being well beaten up, or not having the germs removed would cause it. Too long floating the paper will sometimes cause it; and it will arise from faults in the paper or sizing, causing unequal absorption of the albumen. Whatever the state of the weather, albumenizing should be conducted in a room at a high temperature, at least 70° or 80° Fah.

D. D., Brighton.—We have not seen the portraits resembling postage-stamps to which you refer. It is not improbable that they may become popular, but we cannot speak with much certainty. Any quarter-plate or stereo-scope lens will doubtless answer; the capability of taking twelve heads on one plate does not belong to the lens but to the camera, or rather to the dark slide containing the plate, which must revolve so as to bring the various portions of the plate successively opposite the lens. Mr. Cox, of St. Mark Street, exhibited in the International Exhibition a contrivance for the

purpose. Of course a series of small lenses, properly arranged, would answer the same purpose.

C. W.—Both or either will answer for stereo interiors and give perpendicular marginal lines. We prefer the latter of the two, both for general and instantaneous work.

JOHN INSKIP.—The instantaneous portrait of a baby received is very pleasing indeed, and quite successful as a picture. We shall have much pleasure in publishing an account of your method of securing such effects.

W. B. M.—We prefer the first you name. 2. The No. 1 triple is very suitable for groups in a good light, but would be slow in a bad light. 3. The No. 2 B of the maker you name may be used with full aperture for card portraits, and its advantage over the No. 1 B is much greater rapidly, as the latter must be used with a much smaller stop to get as good definition. The image is moreover, rounder, and has its different planes in more perfect focus. But we have seen excellent pictures taken with both lenses. 4. See article on another page on the double salt of iron and ammonia. It is easily made by dissolving two parts of the ordinary protosulphate of iron and one part of sulphate of ammonia.

S. W. B.—We will give our opinion of a picture if you forward it. See answer above as to your glass.

L. L. II.—You do not state the focus of your lenses nor the size of the stop, both most important elements in forming an estimate of the extent of definition which ought to be expected. Speaking generally, the definition is not unsatisfactory for a "stereo lens" with "large stop." Both pictures, however, are not equally sharp, and if they have received justice in manipulating the lenses are not quite coincident in focus.

B. B.—If you are using the same paper, the same silver bath of the same strength, and the same class of negatives, the same kind of toning bath as before, and yet fail with the same treatment to get as good prints, it is very difficult to make a suggestion. Are you certain the bath is not impoverished and low in silver? Are you sure the paper is the same? Are the negatives brilliant? Is your toning bath old or exhausted? Send us one of the good and one of the bad prints. 2. In Mr. Blanchard's hands the plates in question keep four hours in summer, and twenty-four hours in winter.

J. L.—Of those you name, probably, No. 2.

GOODWYN LEWIS.—As a rule, it is necessary to register a print from each distinct negative, unless they are in all respects identical. In regard to a copy of a work of art, probably the registration of a negative of one size may be sufficient; but, if you are anxious to make the copyright secure, it is best, in regard to a doubtful subject, to be on the safe side. We have handed your note and stamps to our publisher, who will send the form. All communications on the actual business of registration should be addressed to him.

L. S.—Render your nitrate bath neutral; the presence of nitric acid is favourable to mealiness. Use brilliant negatives; wash well in distilled water before toning, or try a bath of acetate of soda first. Let your toning solution be made a week before using it. Tone slowly. If these fail, try another sample of paper.

JUSTITIA.—We have carefully examined your specimens, and the model of the glass room. Much better pictures can unquestionably be obtained in such a room. The first characteristic which strikes us in the prints is the presence of too much diffused light. You have a large glass room with light struggling in from many directions. The pictures require more concentration of light from one source. Remove all light from the end, which should be black. In specimen No. 1, all modelling is destroyed by front light. The same is true of No. 2 and 3. Have dark blinds on the shaded side, and on the lighted side try reducing the extent, or space, through which light is admitted. The chemical part of your work is right enough; but there is a tendency to under-exposure in all the pictures. The definition is very poor indeed, and tends largely to give the unsatisfactory modelling of which you complain. There is no crispness or decision anywhere, and the best possible lighting in card pictures will not give good modelling with a lens which defines badly. See diagram of Mr. Rejlander's room, and also his remarks on it last week.

G. C.—See article on "Glass Rooms" in our YEAR BOOK OF PHOTOGRAPHY for 1863. Also further remarks on the subject in the PHOTOGRAPHIC NEWS for March 6th and April 2nd of this year.

SEA-SIDE.—Give considerably more exposure, and work with a weak iron solution freely acidified with acetic acid. Take care to get the shadows clean and transparent, with some slight touches of bare glass. If you intensify after fixing, first apply a solution of iodine to the film as recommended in our ALMANAC. Take care to prevent diffused light entering your camera.

C. F. WATSON writes to inform us that grey vignettes, or vignettes softening into a tint instead of into white paper, were taken by himself and brother in 1861, long before Mr. Harner wrote on the subject. It is very possible they did, and very possible that they did them well. We produced vignettes in the same style many years before that, and so, doubtless, have others. We again repeat, Mr. Harner made no claims of discovery on the subject, but he carried out with great skill, and with great variety of effect, a familiar idea, and then published for the benefit of brother photographers a detail of his ingenious manipulations. Several Correspondents in our next.

Photographs Registered During the Past Week.

- MR. THOMAS WORDEN,** Newcastle-on-Tyne,
Two Photographs of Old Buildings in the Bigg Market, Newcastle-on-Tyne.
- MR. WILLIAM DOWLEA,** St. Mary's Church, Torquay,
Photograph of Nave and Chancel of the Parish Church of St. Mary, near Torquay.
- MR. JOHN STEART,** 13, Buchanan Street, Glasgow,
Photograph of Rev. Wm. Clark.
- MR. DANIEL DOWNEY,** 9, Eldon Square, Newcastle,
Two Photographs of Venerable Archdeacon Prest.

All Letters, Works for Review, and other Communications for the Editor, should be addressed to the Office, 32, PATERNOSTER ROW, LONDON.

THE PHOTOGRAPHIC NEWS.

Vol. VII. No. 241.—April 17, 1863.

CONTENTS.

	PAGE
The New Iron Developer	181
Ammonia in Printing	181
Amateur Photography in America.....	181
Critical Notices	182
Scientific Gossip	183
Impressions on Chromate of Lead. By Dr. T. L. Phipson, F.C.S., &c.....	184
Copying and Enlarging. By A. Macnab.....	184
Substitutes for Albumen for Positive Printing. By H. Cooper... 186	

	PAGE
A Word about Toning. By Professor C. F. Himes	187
Eden's Patent Microscopic Camera	187
Collodion Wet or Dry. By M. P. Abbe Despratz.....	188
Proceedings of Societies	188
Correspondence.—Foreign Science, &c.	190
Photographic Notes and Queries	191
To Correspondents.....	192
Photographs Registered during the past Week	192

THE NEW IRON DEVELOPER.

As the double salt of iron and ammonia seems likely to become a favourite developer, a few more words on the subject may not be uninteresting. We have, in the first place, a slight reclamation to make. The suggestion for its use is almost universally accredited, by the photographic press at home and abroad, to M. Meynier. This gentleman called attention to its use at a meeting of the Marseilles Photographic Society, held on the 8th of October, 1862. Two months previous to that date, this salt had been recommended as a developer by the *Photographic News*. On page 374 of our last volume, published on the 8th of August, 1862, the nature, properties, and manufacture of the salt are fully described, and its use as a developer in place of the ordinary protosulphate recommended. That the suggestion might be quite original with M. Meynier we do not at all doubt, nor that it has received a considerable impetus from his recommendation. The matter is not a very important one to reclaim; but since the salt will very probably come into general use, it is worth while placing these facts, as to its first application, on record.

As to its value as a developing agent, opinions generally seem, as we have said, in its favour; but as to the precise amount of excellence there appears to be some uncertainty. In our own hands it has a slight advantage over the ordinary iron developer in giving cleaner shadows and intenser lights; but we have not found any palpable difference in the length of exposure required by the plate in the camera caused by its use: some of our friends, on the contrary, are decidedly of opinion that it permits a shorter exposure in the camera, and yields a very harmonious image with such short exposure. The unquestionable advantage it possesses is that the crystals, even when kept in loosely corked bottles, do not become per-oxidized. In solution, however, a small portion of a per-salt is formed, so that the developer is not deprived of the qualities, regarded as valuable by many photographers, which the presence of a small amount of the per-sulphate produces.

The double sulphate is very easily prepared; two parts of sulphate of iron and one part of sulphate of ammonia are dissolved in, say four parts of water. The solution is then gently evaporated, over a water bath is best, until signs of crystallization are seen, when the vessel is put aside to cool without disturbance, when the double salt is formed in beautifully clean and clear crystals. For those of our readers who are wishful to try its effect and have not the opportunity of procuring it, the manufacture is a simple matter, and both the salts of which it is formed may be had of any chemist. For experiment it is not necessary to crystallize the double salt, the solution itself may be filtered, and with the proper addition of acetic acid, used at once.

As regards its energy as a developer, it must be borne in mind that, theoretically at least, the double salt is not so active as the same weight of ordinary protosulphate, thirty

grains of the double salt being equivalent in energy to about twenty of the ordinary protosulphate.

As we have received many inquiries as to the price of the double salt of iron and ammonia, and where it may be obtained, we may mention that it will shortly be kept by photographic chemists generally, and sold at a price not much higher than the ordinary protosulphate of iron. We may also add that we have recently received from Bailey and Son a very fine sample, which is put up in pound bottles, which are sold for eighteen pence each.

AMMONIA IN PRINTING.

FROM recent American intelligence it would appear that the *dernier mot* on the value of ammonia in printing has not yet been spoken. Mr. H. T. Anthony announces a discovery that by using a solution of moist oxide of silver in a solution of nitrate of ammonia, for exciting albumenized paper, an enormous saving of silver can be effected, whilst rapid printing, easy toning, and good results are also secured. Mr. F. F. Thompson states in the *Amateur Photographic Print* that he has seen some prints by Mr. Anthony on paper sensitized with a silver bath equivalent to *five grains* of nitrate of silver to the ounce of water, and that they were in all respects excellent.

Mr. Anthony, writing on the subject to *Humphrey's Journal*, says:—

The solution used by me could not have been of the strength of twenty grains of nitrate of silver to the ounce of water, yet with it I made a very excellent print which toned very readily, yielding fine black tones and pure whites. The paper is, besides, very sensitive and prints very quickly. My chemist is now making an examination of the matter, and we shall soon have some of the compound for sale. In the meantime I would suggest to photographers to try a 2-drachm solution of nitrate of ammonia, to which as much moist oxide of silver should be added as it could dissolve.

It will be seen that no allusion is here made to the proportion of chloride used in preparing the paper, a somewhat important element in the question. The subject is, however, interesting, and we shall duly apprise our readers of the further developments of this subject.

AMATEUR PHOTOGRAPHY IN AMERICA.

AMATEUR photography has been progressing of late amongst our friends in the States. In point of numbers they are still, probably, far behind this country; but what is lacking in numbers is made up in enthusiasm. Amongst other illustrations of this enthusiasm, we may mention the recent establishment of a periodical, entitled *The Amateur Photographic Print*, the editor, printer, and publisher of which is our esteemed correspondent, Mr. F. F. Thompson, the late Secretary of the American Society. Three numbers of the periodical are now before us, which are full of fun and in-

formation, a few samples of which we propose to lay before our readers. To indicate exactly the position of the new periodical, we make a brief extract from its prospectus:—

The *Amateur Photographic Print* is just what the title indicates. It is issued for the benefit of the members of the Club, and for their mutual edification. It is printed and issued by the secretary solely. He sets the type, locks the form, and prints the sheet on a private press in his own photographic "den." The publisher being purely an amateur, of the laziest kind, the precise days of issue will depend very much on time and pleasure; but he intends to issue the Photographic Print monthly, if not too lazy.

In fact, this is to be a purely independent sheet. The terms of subscription are of the most liberal kind; filthy lucre being entirely disregarded, and the whole number of subscribers being on the free list. Only the members of the Club will be recognised as having a right to blow-up the Editor, and they, in return for this privilege, will be expected to keep THE PRESS alive by frequent contributions. Short articles written to the point will have the preference. Short, because our compositor, being a green hand, would be "stumped" with a long job, and the d—l (we mean the one in our office) can't find room on the press for but a limited amount of matter.

The first article is headed "Photographic Quarrels," in which provision is made for the possible escapades of some of our pugnacious friends. We make a brief extract:—

PHOTOGRAPHIC QUARRELS.

"No quarrelling allowed." This notice appears in the "studio" of one of our enthusiastic dog-fanciers, and if Carlo or Towzer grow uncivilly, they are turned out of decent company. We notice that this little world, only twenty-five thousand miles broad, is not wide enough for more than one photographic paper to swing clear in, without striking against some other one, and so we expect, when we say black is black, or white is white, to hurt the feelings of somebody, and start a controversy. We say we expect this, and therefore we announce our intention of sailing the heliographic ocean of the universe alone, regardless of all small potato concerns that presume to disagree with us or get in our way.

With the second number of the *Print* a presentation photograph was issued by the Editor, in regard to which he observes:—"We do not wish to kill any of the other journals with envy, nor do we wish to kill ourselves with braggadocio, but we think that our presentation print 'knocks the chips' from anything yet done." This number, which contains an article on "Brass Toning" by the Editor, concludes with a somewhat plaintive appeal to contributors. The Editor thus addresses his friends:—

Gentlemen of the Amateur Photographic Exchange Club! We have not had one line for the *Print* from any of you. But two of you have even spoken cheerfully to us. As our President of the United States would say, "That reminds us of a little story."

In New York three policemen were sent to examine the Twenty-seventh Street haunted house. One was posted at each door, while Jim, the third, was to go up stairs to find the ghost. He expected to hear unearthly noises and horrible sounds; but he was disappointed. The silence was terrible. The gloom was deepening, and Jim shook with fear. His teeth chattered as he turned the stair head, but still there was that horrible darkness; that terrible silence. He peeped over the banisters and saw the guard in the front door. He could stand it no longer. He croaked out in a voice hoarse with terror, "Say! Fellars! Whistle or suthin', or there'll be a dead perlice-man up here."

Gentlemen of the Club! Jim needed encouragement. You are out on the sidewalk of the photographic world, with your hands in your pockets, looking at life in the street, while we are groping alone in the dark gloom of Journalism in dreadful silence.

Gentlemen of the Club!! Whistle or something! or there'll be a dead *Print* around here.

The third number opens with an article on toning by Professor Hines, in which he refers to Mr. Thompson's claims on behalf of "brass" in toning, and states that his toning solutions work better when copper is present. An article on the Amateur Photographic Exchange Club states that the "day is near when Brother Jonathan will enjoy amateur photography as much as John Bull." The writer anticipates that after the peace shall have been established the numbers will increase by hundreds instead of tens as hitherto. We scarcely imagine that professional photographers will endorse the same writer's reasoning in the following remarks:—

An amateur is generally a better workman than a professional, for the reason that it is not his *labour* but his *amusement*; and he can spend as much time over a single picture as is requisite to make it perfect. He can travel where and when he will, and has the widest choice of subjects. He has no living to make, no grumbling customers to hurry him up, no one to please save himself and his wife.

A presentation print which accompanies the third number is an etching on collodion, by Professor Rood, printed photographically by the Editor, illustrating a paper by the latter gentleman, read before the American Society. The mod of

producing these etchings given by Professor Rood is interesting. He says:—

The plates are made by Mr. Enenger's process. The glass plate is coated with an adherent collodion (sensitized with the alkaline iodides, and rather old), placed in the bath as usual, removed from it, and held in the hand before a window for one or two minutes. It is then developed with sulphate of iron, and well washed and dried. It does not go into the hypo.

The drawing more or less complete, is made on letter paper, and the outline traced through this on the plate, using common tracing paper and a small rounded point; or the drawing, if it be slight, can be made directly on the plate with a pale wash of india ink.

The plate is then placed on black velvet, collodion side up, and the drawing made with a common needle, fine or not as may be desired, which is set in a wooden handle.

The manipulation is much the same as in making a drawing with a pen on paper; and as every line drawn by the needle shows as a black line on a white ground, the effect can be judged during the operation. When the etching is finished it is varnished, a proof print struck off, and necessary alterations in the plate are made.

Properly speaking, a complete copying on paper in light and shade should first be made, and the etching derived from this; though in the etchings which I have executed, and which were sent to some of the Club, this was not done, nearly all the work being made at once with the needle.

The object of the *Amateur Photographic Print* appears to be fun, as much as photography. It succeeds well in combining both, and we hope again to draw from its pages.

Critical Notices.

A TREATISE ON POSITIVE PRINTING. By THOMAS SUTTON, B.A. London. LAMPRAY, TIBBITTS, and Co.

A FAMILIAR and intelligent treatise on the production of positive prints is certain of a ready welcome from all photographers. Notwithstanding the acknowledged importance of printing, and the many unacknowledged difficulties connected with the subject, there have been but few treatises on the subject, and no instruction book, that we remember, devoted solely to printing. Mr. Sutton's pamphlet, as announced in the preface, "has been written chiefly as a guide to those who use the patent albumenized paper, which is sized with india-rubber before using the albumen." But it is something considerably more than such a guide: it is a thoroughly intelligent and interesting treatise on the general subject of printing, which no photographer can read without profit. The whole subject is lucidly discussed, and the author's own practical conclusions clearly stated. We recommend every one of our readers to possess this little work.

THE ISLE OF WIGHT. A Series of Views Photographed by ROBERT GORDON, Bembridge, I. W.

This is by far the best and most complete series of views of this charming island we have seen. There are few places more abounding with subjects for the camera, in the shape of wood and water, rustic cottages, leafy lanes, sylvan nooks, &c., &c., and few which have hitherto received so little justice. In Mr. Gordon's series, however, we find many very excellent photographs, and, what is better, many very beautiful pictures; the point of view well selected, the photograph harmonious, free from chalky lights or black shadows, and without a mass of white paper in place of a sky.

In many of these pictures, which are, we should remark, on twelve by ten plates, a natural sky with pleasing clouds is secured, adding immensely to the value of the pictorial result. The means by which this is effected on large plates is, as we recently stated, by the use of a one-grain iron solution, prior to the application of the regular developer, consisting of eight grains of protosulphate, and twenty minims of acetic acid to an ounce of water.

We have not space to notice each picture in detail, but may mention a few which we consider especially good. "Little Jane's Cottage," a spot rendered famous by the Rev. Leigh Richmond as the residence of the "Dairyman's Daughter," is a very charming photograph, brilliant, yet soft and harmonious, with an atmospheric sky and indefinitely indicated clouds; a rustic figure just entering the

garden gives life to the picture. Several views of, and about, Bonchurch, are very fine; we may especially mention a lane scene, with figures, as an exceedingly fine picture. A View of Ventnor is a very perfect photograph; the mass of white houses in the blazing light, are not chalky, the water is transparent, and the dark rocks in the foreground are full of detail. The "Crab Inn," Shanklin, the "Keeper's Cottage," the "Old Manor House," "Yaverland Church," and others, are all excellent pictures. "The Village Lane" is a very pleasing picture, and by the sacrifice of about three inches at the right, might be made perfect. In the majority of the pictures before us, Mr. Gordon has achieved complete success, and rendered justice to the charming scenes he has depicted.

HER MAJESTY THE QUEEN. Photographed from Life by the late Mr. C. CLIFFORD of Madrid.

This is, in many respects, one of the most interesting portraits of the Queen ever published. It was photographed in the year 1861, by the late Mr. C. Clifford, an able English photographer, residing at Madrid, who was entrusted by the Queen of Spain with a photograph, as a present to the Queen of England, together with a request that Her British Majesty would send in return her portrait. Mr. Clifford then received Her Majesty's command to produce the present photograph. It is probable that Mr. Clifford was scarcely prepared for this honour; he had, however, recourse to Mr. Ross for assistance, who furnished him with a suitable lens, and in the middle of November, Her Majesty standing some distance within the orangery, the only light reaching her being that passing through the open doors in front, the camera out on the terrace, he succeeded in obtaining a very good negative. The portrait gave Her Majesty and the Prince Consort so much satisfaction, that they gave Mr. Clifford permission to publish it; a step which has been delayed, however, until the passing of the new Copyright Act should protect the picture from piracy.

The size of the picture is a trifle under 12×10 on a mount 24×18 . Her Majesty stands with folded arms, arrayed in semi-regal costume; the dress and train being of handsome black watered silk; she also wears a coronet of diamonds.

The photograph is, considering the circumstances under which it was produced, amazingly perfect. Something, perhaps, is left to desire in the matter of expression, and the background furnished by the interior of the room, having been stopped out, leaves this part of the picture less satisfactory than might have been desired. The picture is, nevertheless, the most imposing portrait of Her Majesty which has been published; the only photograph, indeed, which is suitable for framing, and will, doubtless, have a very large circulation.

Scientific Gossip.

PREPARATION OF ALCOHOL FROM COAL GAS.

REMOURS have lately been heard in the chemical world of a discovery by a young French chemist of a process of manufacturing alcohol, which, if successful, will entirely revolutionise this branch of trade and will confer a great benefit on photographers and others who require this solvent for business or experimental purposes. The fortunate discoverer is a M. Cotelte, and the raw material from which he evokes such a magical result is nothing more or less than coal gas! Coal gas, as our readers doubtless know, is a highly complex mixture of various gases and vapours, containing amongst others, hydrogen, olefiant gas and other hydrocarbons, light carburetted hydrogen, carbonic oxide, carbonic acid, sulphuretted hydrogen, ammonia, oxygen, and nitrogen. The first three are the only valuable constituents, the others being impurities present in comparatively small quantities. The ingredient utilized by M. Cotelte is the olefiant gas, so called

from its property of forming an oil with chlorine and bromine. The formula of olefiant gas is C_2H_4 , and that of alcohol is C_2H_6O ; they only differ therefore by H_2O , which is the same as $2H$, or two equivalents of water. If, therefore, olefiant gas can be persuaded to assimilate to itself the elements of two equivalents of water, the thing is done. This synthetical branch of chemistry has of late years received great attention at the hands of Gerhardt, Wurtz, Berthelot and others, and in fact the problem of effecting the hydration or olefiant gas by means of sulphuric acid was some time ago realized by the latter chemist. Nobody doubts that sulphuric acid is capable of fulfilling the paradoxical functions of hydrating olefiant, and yet of dehydrating alcohols (as in the ether-making process), according to the conditions of the experiment; and it is tolerably certain that, by working on a sufficiently large scale, alcohol might be prepared in quantity by a modification of Berthelot's process; but that it could be done with anything like the economy claimed by M. Cotelte, we utterly deny. Berthelot, if we remember rightly, caused the olefiant gas to assimilate to itself the elements of water, somewhat as follows:—Sulphuric acid was placed at the bottom of a bottle, and the upper part was filled with olefiant gas. The stopper was then lightly inserted, and the bottle was fastened to the vibrating frame of a saw-mill, where it could be violently agitated day and night for a considerable time. After an immense number of shakes, the olefiant was found to have been absorbed by the sulphuric acid, in the form of sulphovinic acid. This was diluted, and the alcohol obtained from it by distillation. This is almost identically the process now about to be introduced at St. Quentin. The patentee speaks of several different modes of producing intimate contact of coal gas with sulphuric acid. The first is, by means of a pump, to discharge the acid in the form of rain into a leaden receiver containing the gas; the second is a more complex method of operating, but on the same principle; the third is to procure absorption by pressure, as in preparing soda water; and the fourth consists in placing the sulphuric acid in the form of vapour in contact with the gas. It is evident that very little ingenuity is shown in the methods of causing intimate contact between the gas and acid; they are all inferior to the one originally employed by Berthelot, and considering that in his small experiment it was necessary to give the mixture 53,000 shakes before combination was effected, there is every reason to assume that by Cotelte's processes, and on the scale necessary for a manufacturing operation, only a very small portion of the olefiant present in the coal gas will become hydrated. Two other objections strike us as being impediments to the successful working of the process; one is, that coal gas seldom contains more than three or four per cent. of olefiant gas, and every one knows how dilution interferes with chemical action of this sort; another objection is that if the gas is used purified, some of the olefiant will be lost in the sulphuric acid used in the preliminary purification, whilst if the coal gas is employed in its crude, impure state, the ammonia and other bases which it contains will unite with the sulphuric acid, and introduce complications into the after processes. Another difficulty is where to procure the coal gas. Of course, Mr. Cotelte proposes to use the gas at a gas-works, and after passing it through his apparatus, to return it to the gas company for circulation to their customers; or perhaps the manufacture of gas for lighting purposes is to be carried on simultaneously with that of alcohol. In any case, we fear the consumers of the gas will be inclined to grumble at its inferior illuminating quality if Mr. Cotelte has succeeded in depriving it of its olefiant, seeing that this gas is one of the principal illuminating agents of ordinary coal gas.

Besides these objections, which might, perhaps, be got over, there are the more serious ones connected with the manufacturing process; there are to be pumps constantly working in sulphuric acid of almost the strength of oil of vitriol, and the wear and tear of these must be enormous; then again the

acid, after being diluted sufficiently to allow of the alcohol being distilled off, is to be concentrated by heat until it is of the proper density for a subsequent employment. The patentee, on this part of the operation, says that great economy will be found in this source, the sulphuric acid may serve almost indefinitely.

Now the concentration of this sulphuric acid involves the establishment of another factory on a large scale, for the quantity of strong acid to be employed is considerable. M. Cotelte himself admits that it requires about $1\frac{1}{4}$ cwt. of acid to produce one gallon of alcohol, and we may be sure that he has stated the minimum quantity; but this $1\frac{1}{4}$ cwt. has to be diluted with five times its bulk of water, and then this excess of water has to be evaporated down again. The costs of fuel for this will be considerable, and when we add to this the expense of leaden pans, and the wages, &c., we venture to say that the production of alcohol by Cotelte's process, at anything like Cotelte's price (10d. or 1s. per gallon) is a chemical impossibility. Still, it may be possible when the process has been tried on a large scale, and the difficulties as they arise met and combated with the skill which is sure to be applied when the pocket is concerned, to prepare alcohol at a somewhat higher price, but still leaving a profit. On this view of the question, the photographer will have other things to consider. An alcohol built up from its elements ought to be absolutely pure and free from every deleterious empyreuma. In this case the introduction of hydrated olefiant gas into commerce will be a great boon to all practising the art. On the other hand, it is very probable that carbonaceous impurities, sulphur and other things, will remain with the sulphuric acid, and, being liberated with the alcohol, will render this highly impure, and unfit to be used for anything but rough manufacturing processes. Of the two suppositions the latter is by far the most likely, and if it should turn out that this is the case it will be a still further objection to the "process, Cotelte."

IMPRESSIONS ON CHROMATE OF LEAD.

BY DR. T. L. PHIPSON, F.C.S., &C.

A FEW days ago I remarked upon a table in my laboratory a sheet of yellow glazed paper (coloured on one side only), which had very distinctly received the impression of a printed page that had been lying for some time upon it. The black characters of the printed page were here reproduced in *white* upon the yellow ground. I immediately analyzed the paper to know what the colouring matter consisted of, and found it to be chromate of lead. The paper was, moreover, soiled by sulphuretted hydrogen gas, so often required in the analysis of minerals, and which, in the best ventilated laboratories, does not fail, now and then, to attack uncovered salts of lead, copper, &c. These circumstances gave me the key to the mystery: the white characters were evidently formed of sulphate of lead, produced by the oxydation of the sulphuretted hydrogen; this oxydation only occurring in contact with the charcoal of the printed characters, and the oxygen being probably derived from the chromate of lead.

COPYING AND ENLARGING.

BY A. MACNAB.*

As the copying and enlarging of pictures have ever formed a very important element of employment to a numerous class of operators, permit me to introduce to your notice a few simple and practical details bearing upon the subject. That it is of importance will at once be admitted, on the score of the large and increasing demand in this direction, more particularly since the introduction of card pictures, and from the fact of small pictures admitting of being enlarged without the distortion consequent upon using large lenses, so much spoken against by Sir David Brewster. That such enlargements are

appreciated by the public is rendered obvious by the recent call for solar camera enlargements, which, although some optical questions remain unsettled with regard to the instrument by which they are produced, do not fail to become exceedingly attractive, and which, ere long, it is anticipated, will throw into the shade their Lilliputian originators; and whilst advertent to those pictures, we must for a moment refer to the pleasure with which we listened to the paper read to the members of this Association on such enlargements, and so ably illustrated by Mr. Stuart, and still more recently by Mr. Douglas, at our late conversazione. The following remarks are not intended to detract from or impugn the merits of that class of pictures, but to bring before your notice a different instrument, which serves as a medium by which parties not possessed of a solar camera may by its aid effect enlargements to a considerable extent, without loss of detail or fear of distortion, whilst it has the advantage of not requiring direct sunshine, but can be wrought out in a quiet diffused light.

This method is not advanced as new, having long since been applied; but as many are not yet aware of its value, and the immense facilities it affords for the reproduction of negatives from one single sitting, it occurs to me that this subject will form a companion paper to those preceding. In business, as a matter of course, we wish to find the best and readiest method of attaining our object; and in thus sketching my mode of proceeding, I do not want you for a moment to suppose that it is the most perfect, but simply as I have found it in my experience—the most suitable and convenient. My first attempts in this direction caused me much annoyance; allow me for a moment to refer to it. A small 1-6 plate had to be enlarged to 1-1 size plate. The picture was put up in order to be copied, which I proceeded to do with a whole plate, "Sheppard" lens. After focussing the image sharp upon the screen, and, as I thought, in condition to make a good picture, conceive my chagrin, after exposing and developing the image, to find a terribly blurred and confused abortion—if such a phrase can be applied to a conception of this sort. What could be wrong? Had the camera moved, or the plate got out of its place, that the resultant picture should be so far from sharp? Another and another plate was tried, with a like success, until I had to abandon it in despair. Another of my difficulties was in the arrangements of the camera, and the proper adjustment of the picture to the plane of the axis of the lens. Much time was taken up in getting the one parallel with the other. After much consideration, it struck me that a very simple way of overcoming this obstacle was, to construct a long board, on which to place the camera, having an upright grooved frame at one extremity to admit of a cell, similar to that used for exposure. Into this cell place the picture to be copied, arranging the camera in position, and at the right distance on the board. We will now suppose that the picture has to be copied size for size, or under. In most cases I use a Grubb card, No. 3 lens, well stopped down. Glass positives are generally difficult to manage, and few covet this kind of work from the unsatisfactory results often obtained. Should it be a glass positive to be copied, in which the clothes are black and underdone, with the shadows strongly marked upon the face, the exposure will require to be prolonged an unusual length of time, otherwise the result will be far from satisfactory, with a highly-iodized and full-bodied collodion in a good working bath, in such a case, will yield the best return for the labour expended. Overdone and well-defined positives usually give good results, and not unfrequently the copy is superior, in a photographic point of view, to the original. In copying daguerrotypes, first free the surface from the fine particles of dust which usually adhere to pictures of this description, with a soft camel-hair brush; if the positive is somewhat faded, showing a blue or brown haze on the surface, a weak solution of cyanide of potassium carefully flowed over it will remove the oxydation, and render it more suitable for copying; this done, observe the way the plate has been buffed, allow the striping to run perpendi-

* Read before the Glasgow Photographic Association, on Thursday, April 2, 1863.

cular to the front of the lens; this is important to free the picture from the buffing lines observable on the original; failing this precaution, these streaks become painfully distinct and offensive. If your camera has a swing back, be careful that it is set fair and plumb, or your copy will be out of proportion. A little attention at this stage will save much trouble and vexation, not to speak of a ruffled temper. Adjust to copy for proper size, and take precaution to guard against reflected light, by covering the camera and mounting the lens with dull black cloth, or, better still, velvet; allow a full flood of northern light to fall upon the plate; or it may be sometimes an advantage to have a blaze of sunshine: much depends on the subjects to be copied; the same rule applying to the daguerreotype as to the collodion positive, in the case of its being underdone or well defined. There are many other minor points of detail in the manipulation upon which your discretion must be brought to bear, according to the circumstances which may present themselves, which, in a paper of this kind, would occupy too much time and space to particularise and enumerate; but one advantage in this really simple and inexpensive mode is, that it can be put up and taken down in less than two minutes, should you be disturbed in your copying, and required to leave off and take sittings. I am presuming you have but one glass house for operating. By using a cell, or holder, for the plate to be copied, you can at pleasure expose or cover it up, and put it past in a place of safety till a more favourable opportunity offers for the successful completion.

Since the introduction of the cards, the demand for direct large pictures has been very limited, such orders now being like "angels' visits, few and far between;" yet, from the cards a new demand has arisen, and inquiries are made, such as: Is it not possible to give us large pictures as beautiful and as truthful as those charming little miniatures, so that they may be coloured and made suitable to hang in our drawing-rooms? I found it rather a difficult matter to meet such a demand at first, from the fact of not having the necessary apparatus. Some there are who can work with almost anything—construct a clock, it may be, with a pen-knife, or perform several mechanical feats similar, with indifferent materials; but I think it must be admitted by all, that good instruments are indispensable to successful manipulation. It is an axiom that "what is worth doing, is worth doing well." We may often entertain the notion, and yet have great difficulty in its realization. Such I found to be the case in my first effort to produce large pictures from small ones; and here I must add, that of all the professions that I know of, requiring the operator to have his wits about him, there is none so much so as the photographer, as he must possess an aptitude to suit himself to the varied circumstances which are continually presenting themselves, in ever-changing, never-ending, forms and phases, and which no rule can well define. Perception in a high degree, to which we must add a thorough care and watchful attention, in regard to those mementoes of the "gone, for ever gone," entrusted to his charge for copying, &c. Such qualities are essentially requisite for the successful prosecution of the various branches of photographic reproduction, as the slightest inattention to those invaluable keepsakes, may often cause irreparable discomfort to those to whom they may belong. It often happens that such do not escape scatheless. You have many assistants, and when anything goes wrong, all are more or less ignorant of the cause. The knowledge of such accidents having occurred, often prevents parties from allowing those souvenirs to be copied, owing to the risk which has to be run in their attainment. As an instance of this, I may mention it was once my lot to observe, whilst in the gallery of a photographic friend, a lady whose face wore the aspect of the most earnest anxiety. After her departure, I learned that she had come for the purpose of having a daguerreotype copied. The engagements of the gentleman prevented him from seeing the lady. Day after day she had called, but persisted in not allowing any one to handle the much-prized picture, or to communicate

her business to any in the establishment. Day after day did she toil, climbing up those long and weary stairs leading to his studio, till at length she inquired if Mr.— was a myth that could never be seen. Having succeeded in obtaining an interview with the artist, it was arranged to copy the picture, during the manipulation of which she sat patient and uncomplaining, never for a moment allowing the picture to leave her sight until the operation was completed. Pardon this digression.

With very crude materials I made one or two abortive efforts to produce large pictures direct from small prints, but this mode I eventually discarded for the following simple method; let me remark, "*en passant*," that the first I produced were done in the most rude and extemporary manner, to find how far the system might be successful in my hands previous to getting a more complete and systematic apparatus. The plan worked well, and my wish to enlarge from small negatives was thus realized.

METHOD.

Take an unvarnished "carte de visite" negative, or negative of any sort unvarnished requiring to be enlarged; place it in the cell holder, with figure inverted, collodion film towards the lens, fix it in the slide with opaque gum paper so that no light be admitted, save passing through the negative, with the slide up; turn an enlarging camera with lens reversed, or end for end. I am supposing that a common portrait combination is to be used. Draw back your camera until the image appear of the desired size upon the ground glass; stop down to give sharpness; have it so arranged that it is placed against the clear sky; where this cannot be done, place a sheet of white paper against the window immediately in front of the negative, at a distance of at least twelve inches, that it may be out of focus. If the negative be a dense one, use a thin collodion, a good positive highly bromized and free from crapy lines; give a long exposure, and develop with strong iron, say thirty grains to the ounce of water, continue to develop this plate until there is detail all over the face. Don't be afraid of overdoing the dress. Clear the iodide off with cyanide and examine the plate as to the suitability of its being used as a transparency. If the negative is thin and full of detail, much shorter exposure will suffice, with a developer not stronger than fifteen grains to the ounce of water. In all cases the character of your negative must regulate the time of exposure; and the careful timing of the plate will greatly modify your transparency. When you have obtained a transparency, dry it, and after removing the negative, put it into the cell before-mentioned, observing the same precaution as with the negative, or, as the glass is now transparent, you may have a chimney-top or window stuck into the body of your subject. Again, adjust the camera to get the image the required size upon the focussing-screen; take a plate with good negative collodion the usual way, but shorten your exposure to about one-fourth of the time required for the transparency, although the enlargement may be considerable. These remarks equally apply in copying stereoscopic transparencies or slides for the magic lantern. I am indebted to the kindness of Mr. Spencer for the use of two plates that I might illustrate the subjects of this paper, and show the capabilities of this method for the reproduction of negatives. It would be a gratuitous statement were I to allow you to believe that this system is free from trouble, or that you can expect work as perfect by it as a negative directly from the subject (could that be obtained without distortion), or by the solar camera, the inequality of the glass, the imperfection of the collodion film, dust, spots, comets, and numerous other accidents being all fatal to perfect success. On the other hand, the advantages afforded are indeed considerable—first, that of obtaining large negatives from small ones, and in any number, from one sitting, this alone being exceedingly serviceable where pictures of popular men are required to be reproduced; second, when the sitter, from a nervous disposition, is unable to sit the length of time requisite for a large picture, even were he willing to have such done; third, the

ability to produce the beauty and truth of the card five or six diameters; fourth, the reduction of large pictures to card size, and the great fact of being able to work such with very moderate light, all conspire to render this mode an exceedingly attractive one to the photographer, especially as the humblest operator has the means necessary within his reach.

SUBSTITUTES FOR ALBUMEN FOR POSITIVE PRINTING.

BY H. COOPER.*

THE finding of a substitute for albumen, for positive printing, has for a long time, more or less, claimed the attention of photographers, but I do not think that sufficient perseverance has been shown in the pursuit.

Many, I dare say, have tried an experiment or two, met with no good result, and fallen back upon albumen, leaving the trouble of finding a substitute to others possessed of more patience than themselves.

Only those who have gone on with their experiments can know the difficulties that spring up at every point. They are such that it requires many a glance at the golden end in view to keep the enthusiast from giving up in despair.

The subject of printing has at no time received the attention it deserves. Negatives can now be produced nearly, if not perfect; and it seems to me very strange that more care has not been shown in that process, by which their beauties are exhibited to the world.

As has been recently remarked, every photographer ought to produce the best result, to have the printing of his negatives under his own supervision.

But yet, when perfect prints are produced, the chances are that they are not permanent, and in a few years, or even months, their beauties begin to fade; so that, if it is the portrait of a handsome young lady, the likeness keeps pace with the original. It is a most essential point that photographs should be as permanent as engravings.

Photography is a great blessing; for by its means we may possess faithful records of places and events of the greatest national or private interest, and of the features of those far distant, or who have passed away from among us to that "bourne from whence no traveller returns."

But what is more grievous than to see the cherished likeness of a lost one gradually fading away, when we had hoped to hand those loved features down to generations yet to come.

There are some remarks of Washington Irving's on the introduction of the printing press, which apply with such force to photography, that I am sure you will pardon me for quoting them in a paper which professes to dwell upon processes and formulæ. He says:—

"The recent invention of the art of printing enabled men to communicate rapidly, and extensively, their ideas and discoveries.

"It brought forth learning from libraries and convents, and brought it familiarly to the reading desk of the student. Volumes of information, which had before existed only in costly manuscripts, carefully treasured up and kept out of the reach of the indigent scholar and obscure artist, were now in every hand.

"There was, henceforth, to be no retrogression in knowledge, nor any pause in its career.

"Every step in advance was immediately, and simultaneously, and widely promulgated; recorded in a thousand forms, and fixed for ever. There could never again be a dark age; nations might shut their eyes to the light and sit in wilful darkness, but they could not trample it out; it would still shine on, dispensed to happier parts of the world by the diffusive powers of the press."

In what a greater degree does not photography accomplish all these blessings!

I have made the foregoing remarks to impress upon you the importance of the subject, "The improvement of formulæ for photographic printing."

We *must* make our prints more permanent; and as it is exceedingly dangerous to employ albumen for printing processes, I, as you are aware, am a great advocate for its removal altogether from our formulæ.

I will briefly call your attention to the only advantages possessed by albumen. It gives great fineness of definition combined with a high degree of transparency, and depth in the shadows (which last, allow me to observe, is not always according to nature. I think I shall be supported in this idea by many).

These two good qualities are set against a long array of serious defects.

1st. The trouble and vexations failures in manipulation.

2nd. The great uncertainty of the result to be obtained.

Two sheets of albumenized paper very seldom being alike.

3rd. Its proneness to mealiness, and what I term *scarlet fever*, viz., large patches being left unacted upon by the toning bath. This is really a species of mealiness.

4th. Its great liability to become yellow by sulphurization, and thereby cause fading of the image.

5th. Its great gloss of surface, which is very inartistic.

There are many other faults to be found with poor albumen which I need not enumerate.

I shall now make a few remarks on the processes that appear to me to stand any chance of beating albumen out of the field.

The processes in question are, the resinized paper, paper prepared with india-rubber, and the new enamel paper introduced by M. Schering or Herr Liesegang, or by both these gentlemen.

On the subject of resinized paper I have not much to say, as I have made no alteration in the formula, except in the bath, which I now use of the strength of at least 100 grains to the ounce (more commonly 120), and I only float the paper from two to three minutes.

The bath should also contain 5 or 10 per cent. of alcohol, as I recommended in the first instance, or sometimes the paper will be found to repel the solution, causing a most disastrous effect.

(Mr. Cooper here exhibited a piece of paper that Mr. Simpson had received from a correspondent, in which one half was quite insensitive to light, and it appeared as if a solution of nitrate of silver had been carelessly brushed over without forming any chloride in parts.)

The only other point is to wash the prints finally in boiling water.

From the india-rubber paper I expected much better results than I have as yet obtained.

It decidedly gives cleaner lights and as good shadows as resinized paper. The following is the *modus operandi*:—Procure some pure india-rubber or gutta-percha, that sold in thin sheets is the best; dissolve it in a little chloroform, and add it to benzole in the proportion to make a solution of from two to three grains to the ounce. Shake it well, and immerse the bottle containing it in hot water till the solution is bright and free from muddiness.

Allow it to settle for some time to prevent white spots from being visible on the finished prints.

To prepare the paper, pour some of the solution into an even bottomed dish and immerse the paper in the way I described for resinizing paper.

The draining is the most important part of the process, and where a failure is most likely to occur: the paper must be so hung that one corner is lower than the other, and just before it ceases to drip reverse the position of the sheet, so that the solution may drain from the other bottom corner.

The difficulty is to get a suitable sample of benzole, as it is generally very liable to run into greasy streaks. If it has originally the least tendency this way it will only be increased by the addition of the india-rubber or gutta-percha. When the paper is thoroughly dry it may be floated on a

* Read at a meeting of the South London Photographic Society, April 9th, 1863.

solution of any of the chlorides of from 5 to 10 grains to the ounce.

A little Iceland moss may be added to the salting solution with advantage.

Float three minutes on a silver bath of 60 grains, slightly acid. Or a combination of the nitrates of silver and ammonia may be used, formed as follows:—Make a solution of ammonia-nitrate of silver, 100 grains to the ounce, and add nitric acid till the solution is neutral or faintly acid.

By the bye, plain ammonia-nitrate of silver answers very well for this paper.

The toning, fixing, and washing is performed as usual.

We now come to the consideration of the enamelled paper. Of this I have great hopes, and I think I shall soon be able to employ it successfully for cartes and the finest work.

I have not yet made any experiments with it, as I only had a piece of the size of a carte de visite for which I was indebted to Mr. Simpson.

I have since received some from Glasgow, so I trust by our next meeting to have some perfect prints on it to show you.

As the piece of paper I received was albumenized, of course, for my purpose, it was necessary to remove the albumen; I accomplished this by floating on repeated changes of distilled water (the object of my using distilled in preference to common water, you will perceive presently), gently dabbing the surface with a clean sponge. To make sure that I had entirely got rid of the albumen, I floated a small piece of the paper on the nitrate bath (I beg your pardon, *nitrate of silver bath* I should have said). I then exposed it to strong sun-light for the whole of a day, when not the least change took place in the tint except at the edges, where the silver solution had come in contact with the unprotected paper. This, also, proves that the enamel is unacted upon by the nitrate of silver. If I had used common water, a slight difference might have been made in the result.

This was, to me, a most satisfactory experiment. I have brought a piece of the paper from which the albumen has been removed; you will perceive that the surface is very nice, although it has a slightly bronzed appearance.

To salt the paper, I floated two minutes on a 7-grain solution of pure chloride of sodium, and then, when dry, on the 100-grain silver bath.

One advantage is, that the paper does not cockle in dipping. The piece I tried printed very red in the frame, but toned up beautifully to a splendid purple; upon fixing, the print lost considerably in tone, but not in strength; but, when dried, it was very much too blue.

I must try and procure some of the paper unalbumenized, and then I can set to work in a systematic manner.

I forgot to mention, that the enamel is insoluble in hot and cold water, and alcohol.

It is also unacted upon by nitric, hydrochloric, and acetic acids diluted with their volume of water. I have tried many experiments to *make* an enamelled paper, but have not, as yet, been successful.

This paper is necessarily very cursory, as through severe cold I have been prevented from carrying out a great number of experiments which I have in hand. In fact, I was rather inclined to postpone my promised communication till the next meeting, as I thought we should have plenty for the evening; but as Mr. Harmer was prevented from fulfilling his intentions, I have done the best I can to open the way for a discussion on this most important subject.

A WORD ABOUT TONING.

BY PROF. C. F. HIMES.*

A WORD on toning: I always have copper in my toning bath, because I use scraps and ends of gold in making my chloride of gold, which *invariably* have copper in them.

* *Amateur Photographic Print.*

My bath seems almost exhaustless in its toning power. It is now more than two months old, has been used at least ten times, and works as rapidly and well as ever.

When I stop toning, I pour it into a bottle, add enough hydrochloric acid to give it an acid reaction, and let it stand. When I wish to use it again, pour it into a tray and add solution proto. carb., soda, until its addition causes no more flocculent precipitate (sometimes this bath is almost *mushy*), then put in the prints. They tone in from one to five minutes, and change very little in the hypo. I also put in a pinch of hypochlorite of lime occasionally, never any salt, as I wash my prints in salt water, from which I transfer them to the toning bath; and the repeated acidifications and neutralizations give a large supply of chloride of sodium. My *stock* solution of chloride of gold is quite acid, as I never evaporate the solution to dryness, nor do I do anything in the way of neutralizing until it is used, as it keeps much better acid.

I think if there is any virtue in *brass*, I get it in my way of operations, and I must say that since I have been using this coppery gold solution, it holds out much better than before.

EDEN'S PATENT MICROSCOPIC CAMERA.

A VERY ingeniously constructed instrument of this character has recently been patented by Mr. A. F. Eden, of Crown Court, Threadneedle Street, the inventor and maker. It is made to serve a variety of purposes, and can be used either for the production of direct miniature portraits suitable for mounting in lockets; for taking reduced copies of photographic pictures to be examined afterwards by the aid of an ordinary microscope; or may be employed inversely for the production of magnified representations of microscopic objects. The instrument may be described as consisting of a photographic camera adapted to the tube or body of an ordinary microscope, and, although the combination serves the purposes already enumerated, the two portions may be disconnected, and each used separately: thus, to the mahogany camera may be adapted a landscape lens of about sixteen inches focus, when it becomes suitable for copying, and for taking small views of any size not exceeding six inches square; likewise the optical portion of the instrument may be mounted on a brass stand, and requires merely an eyepiece to constitute an efficient compound microscope.

The manner of using the instrument may be briefly described:—Supposing it be required for taking a micro-photograph or reduction from an ordinary negative, the latter is supported in the position occupied by the ground glass or dark slide in a camera of the usual construction. This end of the instrument is provided with a large plane reflector attached by a hinge, and capable of adjustment to any angle which may be required to direct the rays of the sun or diffused daylight through the negative and axis of the camera; by means of the microscope object glass in front of the camera, a sharply defined image is depicted upon the screen of a little dark box placed a short distance beyond. The lens may be adjusted and focussed by the aid of a rack-work and pliuon movement; and when the optical perfection of the image is arrived at, the scratched glass is exchanged for the sensitized plate, in this instance represented by a single drop of collodion upon a glass slide of standard dimensions, one by three inches; the exposure will not usually exceed ten seconds in bright daylight, and the development occupies but a single moment, since it is advisable to guard against too great intensity in the minute photographic reproduction, and in order that the speck of reduced silver on the glass may exhibit, under assisted vision, its proper gradation of light and shade. The beauty of the result, and the rapidity with which the whole process is executed, will possess a charm for those whose leisure moments are few, and whose laboratory facilities are of a limited character.

On the other hand, by placing in the little dark box a microscopic object mounted on a glass slide, and removing the cap or stopper which prevents the access of daylight, an enlarged and well-defined image will appear upon the ground glass at the larger end of the camera; having focussed in the same manner as before, this image now presents itself ready to be photographed on merely holding the camera directly

pointed to the sun, or reflecting its rays from the small concave mirror placed at this extremity of the instrument. And, further, by removing altogether the larger mirror, the apparatus will be suitable for taking miniature portraits of sizes varying from that of a grain of mustard seed to such as would be mounted in a small locket. The one-inch lens is that preferred for general use, but a lower power is also provided; both of these object glasses have their photographic and optical foci coincident, no allowance need, therefore, be made in the adjustment of the sensitive plate; and the fact that Mr. Eden was for some years a pupil of Mr. Andrew Pritchard is so far a guarantee for the perfection of the optical part of the microscopic camera.

COLLODION: WET OR DRY.

BY M. L'ABBE DESPRATZ.*

THE mode of developing we have previously described appears, we must admit, to complicate operations: it differs a little from the method usually followed; but as it is based upon oft repeated operations, and as it tends to yield constantly identical results, we have thought it would be useful to make it known with some details. We recur then, for a moment, to speak of pyrogallic acid; for although it is possible to obtain with this agent an excellent development in most cases, that is, when we moderate the action of pyrogallic acid by acetic acid, we do not hesitate to affirm that by proceeding as we have indicated for sulphate of iron, the results will be obtained with greater regularity and facility, when we substitute the action of acetic acid for that of citric or tartaric acid.

Some preliminary considerations must not be neglected. Pyrogallic acid, as is well known, is never employed without the previous addition of another acid. Observation has in fact shown that pyrogallic acid alone, and without the association of another acid, is so sudden in its action, that a complete decomposition of the nitrate of silver occurs instantaneously upon first contact, and that, from this moment, the pyrogallic acid seems to lose its continuing power for developing the image. The addition of an acid always retards its action. Hitherto we have had recourse principally to the vegetable acids, acetic, citric, and tartaric. If on principle we make use of the first, and if we still use it to the exclusion of the others, it is doubtless for this specious reason, that its physical constitution is more in harmony with the collodion film, its diffusion upon this film being effected with the greatest facility. Citric, tartaric, and many other acids beside, doubtless, also possess the property of moderating the action of pyrogallic acid; but viewing their physical constitution, their action, although chemically the same as that of acetic acid, can be exercised under the same conditions only with much more difficulty. The special conditions demanded by citric and tartaric acids are the same as those we have indicated for sulphate of iron, and are almost wholly applicable to them.

In following our researches in this direction, we do not confine ourselves simply to regulating the action of the moderating acid upon the silver bath; we also think that it will be interesting to know whether in securing the good development of the picture, the moderating acids do not modify its tone, and also if the image itself will be accelerated or retarded in its appearance. And thus experience has taught us that in a physical point of view, and especially in the chemical, the choice of acids added to the pyrogallic is not a matter of indifference.

What first strikes attention in the chemical point of view is that the different acids associated with the pyrogallic have evidently a peculiar action. The tint of the picture obtained is not the same with the one as with the others; besides, the acceleration appears to be variable. Finally, if they can contribute to the obtaining of a greater or lesser delicacy, they oppose more or less the tendency to *fogging*. Under these two relations, the advantage seems to be attributable to citric and tartaric acids; to the first especially, which gives

blacks of a peculiar aspect, blue in some measure and of very great transparency in the half-tones; while tartaric acid will give reddish blacks comparable with those of a positive in chloride of silver. With these two acids the picture develops slowly. It is one or two minutes before the darkest parts begin to show themselves, but as soon as they are well out, the entire picture appears with admirable regularity, and with a harmony of tone that leaves nothing to be desired. This slowness in the appearance of the image leads to the supposition, that the reducing faculty of the pyrogallic acid is diminished; but we believe that it is merely slackened. It is, however, not impossible that there is a real diminution, and starting from the fact of a special and coercive action of one acid, we can, in the hope of another action in the contrary direction, make use of some other acid. An action of this kind seems to be the property of formic acid, for example, but we have had no facilities for proving it in our experiments. Whatever it be, there are very interesting studies on this point to be pursued: and it is to be regretted that, hitherto, they have been almost exclusively limited to the employment of pyrogallic acid moderated by acetic acid.

Our studies have, however, not been limited to acetic acid. What we are about to say of citric and tartaric acids, has determined us to seek the means of deriving every advantage from them they possess. In our experiments both have been submitted to similar treatment, and both have comporting themselves alike, and the results obtained, variable with the nature of the acid, have presented themselves in the same degree. Both, therefore, require the same manipulation. As with sulphate of iron, a new sensitizing bath offers, in use, less obstacle to a regular and harmonious development; but as we have said, this is not ordinarily the case; almost always, if not always, sensitizing is made with an old bath, or more frequently, with one made old by artificial means, by the addition of iodides soluble in ether and alcohol, the alcoholic tincture of iodine, or even with a weak solution of nitrate of lead; preparations, more or less complex, and most certainly preferable to a new bath simply prepared with nitrate of silver.

(To be continued.)

Proceedings of Societies.

SOUTH LONDON PHOTOGRAPHIC SOCIETY.

THE usual monthly meeting of this Society was held in the City of London College, on the evening of Thursday, April 9th; Mr. SEBASTIAN DAVIS in the chair.

The minutes of a previous meeting having been read and confirmed, the following gentlemen were elected members of the Society: Messrs. J. W. Osborne, Henry Cooper, jun., and William Cobb.

Mr. MARTIN exhibited some very fine crystals of the double sulphate of iron and ammonia prepared by Messrs. Horne and Thornthwaite, and also some negatives developed by its aid, by Mr. T. R. Mills. Some conversation on the subject ensued.

Mr. G. WHARTON SIMPSON exhibited some prints by Mr. Pouncy's new process, in which the paper was prepared with printing ink and a sensitive salt, exposed under a negative, and cleared by immersion in a solvent of the printing ink, the result being a photograph in printing ink, presenting the due gradation of half-tone. The prints were examined with great interest. As analogous in character in some respects, Mr. Simpson also showed some photolithographs by Asser's process, executed by Messrs. Simonau and Toovey, of Brussels. These were also considered very successful, especially in the half-tone. He also exhibited some specimens on enamel paper he had received from Herr Liesegang, which were much admired. He further called attention, as not less connected than the pictures he had already shown with the subject of the evening, printing, to Mr. Penny's specimens of the effect of fuming albumenized paper, illustrating its value, and to some specimens of his own in which he had failed to secure any advantage by this process.

Mr. COLE presented to the Society some card portraits taken in Rome, of various eminent men; which were examined with much interest.

* Continued from p. 101.

Mr. SYDNEY SMYTH exhibited some very fine enlarged prints by the solar camera, which he explained were produced by development on Hollingsworth's drawing paper, prepared with a bromide and a chloride. The sheets were washed in troughs, and the paper in question was the only kind which, in such large sheets, would bear washing without tearing.

Mr. COOPER showed some pleasing specimens, amongst which was a charmingly lighted copy of a bust of the Princess Alexandra, the print being about half the size of the bust, produced by Dallmeyer's No. 1 Triple lens.

The CHAIRMAN announced that Mr. Harmer was unable to read his promised paper on "Double Printing," but Mr. Cooper would now proceed to read his paper prior to resuming the discussion on Mr. Price's paper.

Mr. COOPER then read a paper "On Substitutes for Albumen in Printing," (see p. 186).

A conversation then ensued upon the enamel paper, a sample of which, with the albumen coating removed, but leaving an enamel surface, he produced, and also a print upon it, salted after removing the albumen. Various opinions as to the constitution of the enamel were expressed. In answer to the suggestion that lead was used in producing a similar surface,

Mr. SIMPSON said that he thought that lead was not employed in this case, as he had tested it with sulphide of ammonium, which did not produce any blackening. He was disposed to think that probably sulphate of baryta was used.

Mr. J. W. OSBORNE thought it very likely that either the sulphite or carbonate of baryta was used, as they were both very suitable substances. It was probably mixed with dextrine or some paste, supplying no sulphur compound. It was a matter of surprise, however, that the enamel remained perfectly intact, after the treatment necessary in removing the albumen.

The CHAIRMAN suggested that a varnish of some kind not soluble in water was the vehicle of applying the enamel to paper.

A Member suggested that it might be soluble glass.

Mr. COOPER thought not, as he had tried that himself. It gave a beautiful surface to the paper, but quite dead, and it became decomposed on coming in contact with the nitrate of silver.

After a desultory conversation, in which Mr. Cooper referred to the fact that the enamel remained unaffected by nitric, sulphuric, or hydrochloric acids,

Mr. MARTIN said that this fact inclined him to the opinion, already suggested, that soluble glass had been used in obtaining the enamelled surface. The silicate solution was probably applied to the surface, which was then submitted to the vapour of carbonic acid gas, which would precipitate the silicate on the paper.

Mr. COOPER's experiments with silicates inclined him to think not, as the solution at once penetrated the paper and left a dead surface, whereas this enamel was entirely on the surface.

After some further conversation, Mr. HARMAN stated that he had found in using resinized paper that a floating of three-quarters of a minute gave more brilliant prints than a longer application.

Mr. S. SMYTH said, in reply to the Chairman, that he used resinized paper for the solar camera and liked the result; the print was more on the surface and more brilliant than with plain paper.

A desultory conversation followed on the relative value of Hollingsworth and Turner's papers, on tinting photographs on resinized paper, on printing on tinted papers, on dyeing or tinting the prints subsequent to printing, &c.

After a vote of thanks to Mr. Cooper, the debate on Mr. Price's paper was resumed.

Mr. J. W. OSBORNE had not had the good fortune to be present when Mr. Price read his paper. He had read his paper with great interest in the pages of the NEWS, and as it was a subject in which he felt interested he had followed it up with some experiments, in the course of which he had found some inaccuracies in Mr. Price's statements. He referred to that part of his paper wherein he stated that M. Gaudin was in error in stating that a hot iron applied to paper which had been rendered damp would coagulate the albumen. He would read the passage from the PHOTOGRAPHIC NEWS (see p. 127 of our present volume). On reading this and remembering his own experience he thought M. Gaudin was right, and his experiments proved that this was so. A very small amount of moisture was sufficient to permit the coagulation of albumen. He had

tried various ways of moistening the paper, and used it with different degrees of moisture. Amongst other methods he might mention he had placed the albumenized paper between sheets of damp paper and allowed it to get just so moist that it was no longer crisp. Strips of this he passed over a heated Italian iron, the plain side in contact, and the result was coagulation. He was not prepared to say that this could be done easily with large sheets. It required, moreover, great care and attention to manage it properly; too great a heat would scorch the paper, and too little would not produce coagulation; and it was more-over possible to scorch the paper without causing coagulation. He had himself been surprised to find that on ironing a sheet of damped albumenized paper, with a sheet of paper over it, coagulation followed. Mr. Price had shown a great readiness to admit any error or mistake he had made, and he felt sure he would be glad to have this error corrected, arising from his too hastily having assumed that coagulation could not be effected in the manner proposed.

Mr. PRICE said he had tried the experiment and no coagulation whatever was the result. He put the paper in an extremely damp place and then ironed as M. Gaudin had directed, but without producing any coagulation.

Mr. OSBORNE was not surprised. It was very difficult to succeed and very easy to fail. He would probably have found that an Italian iron would have answered best as giving the most control over the heat.

Mr. PRICE had used a box iron. He had also had some paper submitted to the steam passing from a safety valve, which, however, produced no coagulation.

Mr. OSBORNE said it was possible that it was equivalent to dry heat, which would not, of course, cause coagulation. In his operations for coagulating the albumen on the photolithographic transfer he had less difficulty in effecting it by floating as the gelatine present held the moisture and prevented evaporation. He found it impossible to coagulate the albumen by floating on an open vessel of boiling water, as the evaporation carried off the moisture from the paper too rapidly; but if the vessel were covered for even a few seconds, coagulation was produced. The operation was, though difficult, still possible; the point to be settled was whether paper so treated could be produced as a commercial article, and if so, whether it possessed any special advantage.

Mr. PRICE was not sure that even if effected by steam, a portion of the chlorides might not be removed by the operation.

Mr. OSBORNE thought it quite possible; indeed one of the samples upon which he had experimented, when printed upon, gave a very unsatisfactory result, and he thought the chlorides had been washed out.

Mr. SIMPSON believed that any steam at a temperature less than 214° or 216° was too moist and would be likely to deprive the paper of a portion of the chlorides, even if it effected coagulation.

Mr. PRICE had many experiments, and had tried steam, because Mr. Simpson had shown him some paper in which the albumen was rendered insoluble by steam. The sheets submitted to the steam from a safety valve, had been moist, for they all stuck together. He had not succeeded in coagulating the albumen in any of his experiments. There was, evidently, great uncertainty as to success.

Mr. OSBORNE said that was doubtless the case.

After some further conversation,

The CHAIRMAN recurred to Mr. Price's objection to the term "coagulation," as produced by metallic salts. He thought the objection not based on certain grounds, as there was no proof that albumen was not coagulated independently of any compound which was formed.

Mr. PRICE maintained that it was a new compound which was formed by the combination, and that it was a misnomer to call it coagulated albumen.

Mr. OSBORNE said there was no proof of chemical combination being formed, substances always combined chemically in definite proportions, and we had no evidence of such combination between albumen and silver.

The CHAIRMAN said it might be an entanglement of nitrate of silver with coagulated albumen, and the term coagulation might be strictly correct in the sense used by authorities.

Mr. SIMPSON thought in such discussions it was most important to define terms, and he thought there could be little doubt that the term coagulate, according to either philological or chemical authorities, meant the changing of a substance from a fluid to a solid state. The coagulation of albumen was de-

scribed by chemists as an isomeric change, and it was certainly not such a change which was produced by nitrate of silver. He believed that chemical authorities had always regarded the insoluble substance produced by the action of strong acids or metallic salts upon albumen as direct compounds between the bodies. To the photographer the simplest evidence of the formation of a combination was the fact that the compound blackened by light. Nitrate of silver alone and albumen alone were unaffected by light; whilst the compound readily blackened. It would scarcely be alleged that any mechanical entanglement of the two or mere intimate contact, without a chemical combination, would enable light to bring about the chemical change involved in the blackening. The fact that the proportions in which these substances combined was not well known was no proof that a definite combination did not take place. If a new compound then were formed, the term "coagulated albumen" did not properly define it.

A somewhat lengthy conversation on the subject followed, in which the Chairman and Messrs. Price and Osborne took part, after which the proceedings terminated.

Correspondence.

FOREIGN SCIENCE.

[FROM OUR SPECIAL CORRESPONDENT.]

Paris, April 15th, 1863.

M. Sabattier-Blot exhibited to our Society an apparatus for operating in the open air without the aid of a tent. It consists of two superimposed boxes, the upper box is the ordinary camera, only its position is reversed, the objective occupying the place where the ground glass is usually found. On the front is a board, which opens upon hinges. Inside this board two brackets are adapted to slides which hold a piece of wood to which is adapted the crutch in the form of a T, upon which the plate is fixed by means of little hooks. This crutch or hook, placed, vertically, is moved by means of a button placed outside, which permits it to be raised or lowered into the several baths.

The groove which admits the passage of the button is formed by means of a piece of caoutchouc or oil-cloth.

The hook which supports the plate is very easily removed by turning a little screw, which permits of the hook being immediately cleaned.

The lower box contains another box lined with gutta-percha, in which are placed two, three, or four glass baths, which by means of a little rack are placed successively under the hook. This operation is performed so exactly, that the hook and the plate it sustains can enter easily, without friction, into a bath of 6 millimetres ($\frac{1}{4}$ of an inch) in thickness. When ready to operate, the hook is removed, and the focus obtained on the ground glass, the prop is then placed; the plate is covered with collodion, and then immersed in the nitrate bath. After it has remained sufficiently long in the bath, the plate is removed and drained for a few seconds, and then exposed. As soon as the picture is taken, the developing bath is brought to its place by means of the rack, and the plate promptly immersed in it. It now only remains to fix and wash it, which can be done in the box if desired, or outside, as many operators do.

The negatives thus obtained are generally weak, but very delicate, and very well adapted for reproducing and enlarging. If it is desired to strengthen them immediately, there is a very simple way of doing it; we can make use of a little box of gutta-percha, into which we let fall the plate and the hook. This box has both sides furnished with windows of yellow glass, through which we can see when the operation is concluded; by this means we strengthen the negatives with as much facility as in the dark room.

The advantages claimed for this apparatus by the inventor are, that the operations are very easily performed, without slides, dark room, or soiling the fingers.

In one of the photographic ateliers of Berlin, a curious phenomenon lately exhibited itself. When alcohol varnish

was poured upon the negatives, dried and warmed, the collodion broke up and came off with the excess of varnish, and only the intense blacks remained on the plate. At first the phenomenon occurred with but a few plates, but it soon began to occur very frequently, so that at last almost every negative was damaged during the process of varnishing. Operators were compelled to use gum arabic instead of varnish, so as not to lose all the fruits of their labour.

When this fact was communicated to M. Vogel, he concluded that the varnish contained some acid. To make sure he added twenty drops of liquid ammonia to two hundred centimètres (seven ounces) of varnish; a flocculent precipitate appeared, which was entirely redissolved upon warming and shaking the bottle.

The varnish prepared in this way no longer exhibited the phenomenon in question. Although we may conclude from this experiment that the acid contained in the varnish was the cause of the destruction of the collodion, testing with litmus paper showed very little acid in many samples of varnish. It may therefore be presumed that there are other causes to be discovered.

The film of collodion does not become insoluble in drying. If we pour upon it some alcohol mixed with a little ether, the collodion breaks up in the same manner as with the varnish. It is therefore probable that the varnish (an alcoholic solution of resin) *dissolves* the collodion. This dissolving will take place if the collodion be very soluble, or if the alcohol of the varnish be very strong; it is easy to remedy this inconvenience by adding a little water to the varnish, say twenty drops to seven ounces of varnish, heated in a retort, a white precipitate is formed, as with the ammonia, which dissolves rapidly upon being shaken.

The varnish, thus treated, no longer acts injuriously upon the collodion film, and leaves nothing to be desired.

The analogous action of ammonia is due only to the water it contains. The neutralization of the acid seems to play an insignificant part.

THE MOTION OF CAMPHOR TOWARDS THE LIGHT.

SIR, my attention has been called to a statement by Dr. Draper in your last number (p. 178), abridged from the *American Journal of Photography*, to the effect that he, Dr. Draper, is the author of a theory of the motion of camphor, &c., towards the light, similar to that which I submitted to the British Association at Cambridge, in October last, an account of which is given in the *Philosophical Magazine* for November last, and in greater detail in a small volume recently published by me, entitled "Experimental Essays."

Dr. Draper has already made a similar statement in the *Philosophical Magazine* for January last, and my reply to him is contained in the *Philosophical Magazine* for February. As many of your readers may not have seen my reply, perhaps you will allow me to re-state it in your next number, with a few additional particulars.

In a dispute of this kind more assertion should be carefully excluded, and the only evidence adduced should be documentary printed and published statements, with the dates open to all the world.

Now I cannot help remarking that Dr. Draper deals in mere assertion when he states, "I finally came to the conclusion that the old theory was incorrect; that the crystallization was not caused by the light, but by the heat. The side of the vessel nearest the sky becomes the coldest, and the camphor crystallized upon it simply by virtue of its being a cold surface. Any thing placed before it to obstruct radiation will prevent the formation of the crystals."

All this, so clearly stated after my own labours have been published, sounds exactly like my own language, and is indeed my own theory. Dr. Draper claims it, but where are the published proofs of his claims? The only attempt at proofs given by him in his letter to the *Philosophical Magazine* in January last, is a question put by him in 1840 in the same magazine, whether the side of the jar next the sun may not, after all, be the colder? This was a passing idea, and he proceeded to test it by the light of an experiment which he describes in his quarto volume, "On the Forces which produce the Organisation of Plants," published

at New York in 1844. At page 124 of the appendix he says, "It might be suggested that when a vessel is exposed to the sun, that part of the glass which is nearest to him may actually be the *coldest*; such an opinion, it is evident, rests on no sufficient grounds." He then describes the experiment, in which a differential thermometer, enclosed in a jar and exposed to the sun, proved that the side of the jar nearest to the sun was the warmer, and adds, "Hence we know that in all cases where crystals of camphor, dew of water, &c., are deposited on the side next the sun, they are so deposited in opposition to an energetic force which tends to remove them."

This is pretty strong evidence that Dr. Draper's theory is very different from mine.

A few more statements from this volume will show that Dr. Draper tried at least six theories to explain the phenomena in question, and failed in all.

At p. 120, he says:—"The sun's rays have the power of causing vapours to pass to the perihelion side of vessels in which they are confined, but, as it would appear, not at all seasons of the year." He then describes a case in which, during December, January, and part of February, "a deposit was uniformly made towards the sun; during the months of March, April, and part of May next following, although every part of the arrangement remained to all appearance the same, yet the camphor was deposited on the side furthest from the sun. *It does not appear that any immediate cause can be assigned for this waywardness.*"

Could Dr. Draper have put forward such a statement as this in 1844, if he had had the slightest idea of the true theory of the motion of camphor towards the light?

Again, p. 122, when a circular plate of glass was put into a glass receiver above the camphor, no deposit was made on the plate. Dr. Draper says, "It was not without surprise I observed that, however long the plate was continued in the beams of light, no crystallization would ensue." Cases of this kind are perfectly explicable on my theory, and, indeed, I give several such.

Commenting on such a case, Dr. Draper says that "to reduction of temperature we cannot look for an explanation." I prove that reduction of temperature is the only means of explanation.

Again, at p. 122, Dr. Draper says, "Why does this condensation take place on the hottest surface, the side nearest to the plate? *We cannot admit that the rays of heat have any active part in bringing about the phenomenon.* On the other hand, they ought rather to exert a contrary effect, antagonizing the powers that solicit the camphor crystals to form, and driving them to the coldest surface. We are therefore reduced to the supposition that, when the light of the sun impinges on a surface of glass, it places that surface in such a condition that it exerts a pressure on the adjacent medium, immediately followed by a condensation of that medium."

I have no idea what this means; but I would ask how it is possible Dr. Draper could sanction such statements in 1844, if, as he says, he had adopted my theory in 1840?

At page 124 he says that "light which has suffered reflection at certain angles seems to have undergone a remarkable modification, being no longer able to put the glass into such a condition that it can cause motion towards the sun." Does this look like settled theory?

Nor is the action of metal screens and tinfoil rings in preventing a deposit at all explained. At page 126 it is stated that "the ring exerts a kind of protecting action," &c. Again, "This action of a ring formed of good conducting materials might be supposed to arise either from its adding something to the surface of the glass, or taking something away from the glass with which it is in contact; or it might be imputed to some change impressed on the ray of light, &c."

The electrical theory is started at page 127, in which it is supposed that a glass exposed to the sun's rays becomes electrified in an opposite state to that of the camphor, and consequently attracts it; but that a ring or screen of tin-foil prevents such action, &c., &c. At page 128 it is stated that, if the inner surface of the glass receiver be rubbed with a glass rod, the camphor will deposit itself on the lines traced by the rod. Although the explanation of this fact is perfectly easy, yet Dr. Draper compares the result with Lichtenberg's electrical figures, and proceeds to ask, "Are we to refer this singular action to the rays of light, to the rays of heat, or to the chemical rays?" He then proceeds to pass the light through solutions of ammonio-sulphate of copper, bichromate of potash, &c., and obtains what he calls "aphelion camphor deposits." He says, "It does not necessarily follow from the phenomena that any pecu-

liar class of rays is emitted by the sun which bring about this action; but if there are such, it is a question of interest to find what is the reason that good conductors of electricity render their action nugatory."

Now is it conceivable that Dr. Draper could have published such statements as these in 1844 if he had had the faintest idea of the true theory? Or is it conceivable that so industrious and ingenious an experimentalist would not have devised experiments to test his theory had it been the same as mine, and which he now admits to be a sufficient one? I have looked in vain for any indication of such an attempt. Instead of any settled theory, I find a large number of theories, and a large number of experiments, but nothing is settled. In fact, Dr. Draper makes a lottery of a number of theories, and draws out blanks so far as the explanation of the phenomena in question is concerned; and when, twenty years later, another inquirer draws a prize, he claims it as having come from his original lottery.

If Dr. Draper advanced the true theory in 1840, it made no impression on himself or on others. No scientific writer, to my knowledge, either in America or Europe (and I have searched far and wide for the purpose), has ever had a doubt that the camphor deposits are produced by the action of light. Nor do I now see any cause to alter one of the conclusions of my paper, viz., that the result of Dr. Draper's labours was "to multiply phenomena, and to leave the theory as it was."

The above statement has already been given in the *Philosophical Magazine* for February last. Should it be necessary, I have other proofs that so late as 1860 Dr. Draper had no idea of the true theory of motion of camphor towards the light.—I remain, &c.,

C. TOMLINSON.

King's College, London, April 13, 1863.

Photographic Notes and Queries.

SATURDAY HALF-HOLIDAY FOR PHOTOGRAPHERS.

SIR,—It was hoped good things would come of the circular issued by Messrs. Ackland and Godbold, soliciting signatures of employers photographic to a form affirming their willingness to concede the Saturday half-holiday to operators, &c., from the 7th of March.

The day certainly appeared an appropriate one for such a change to date from, but it came and brought no change.

Hence my reason for troubling you with the following suggestions:—

That Messrs. Ackland and Godbold constitute themselves bankers for the receipt of "hard cash" to be used to advance the cause of health in Health *v.* Cyanide and others; and that the Early Closing Association's boards would be a good medium to advise the public of our wishes, and how to gratify them.

I would also hint, that the majority of west-end customers on Saturday afternoons are drapers' assistants, who no sooner rid themselves of the last counter-feat than they go in quest of another, and injudiciously bother the photographer with the study of the drapery line in all its beauty.

The aristocrats, by deed and word, some time ago, gave in their adhesion to the half-holiday movement.

I remain, sir, your obedient servant,

TANTALUS.

DIRECT IMAGE ON TANNIN PLATES, &c.

SIR,—It may be perhaps interesting to some of your readers to know of an incident which occurred to me the other day when taking a view, which shows the extreme sensitiveness of the tannin process (or rather a slight modification of it) which I have for some time past used—viz., that after exposing above the usual time for a plate of that description, I found, upon opening the slide to develop the plate, a perfect view on it of the subject, with detail, &c., very well brought out without any developing, filling up an oval space of about three-quarters of the plate with an oval of light round it. That portion of the plate outside of which had as usual only an invisible image on it which was brought out by developing in the usual manner. It is possible, but I am inclined to think improbable, that the plate was not perfectly dry at the time of exposure.

Seeing a letter in your paper by Mr. Bartholomew regarding his morphine process, I find that he has omitted one most im-

portant remark, viz., how many grains of nitrate or chlorido of morphine does he use for a pint (16 ounces) of 30-grain bath solution. Perhaps you can supply this deficiency, as upon these minutiae often a process depends, and they are often forgotten by photographers in describing their processes.—Yours, &c.,

Gibraltar, March 30th, 1863.

ALEX. B. BROWN, Licut., R.A.

[From the print received we are much inclined to think that the centre of the plate had been slightly moist when exposed. Mr. Bartholomew has more than once stated that he uses one grain of muriate of morphia in eight ounces of bath solution.—Ed.]

To Correspondents.

JUSTITIA.—Your specimens exhibit an immense improvement in your lighting: the modelling in the male figure, No. 4, is very excellent indeed. We do not consider the coat at all too light for well-lighted black cloth. Regarding the increased exposure necessary, we fear we cannot help you, except by suggesting a few experiments to admit a little more light without altering the balance or proportion of light and shade. Also try a quick-acting lens, or one which will define sufficiently well with large aperture. We do not know whether the collodion you mention is quick or slow; but the chemical conditions in your pictures seem all right.

A. LEXARIC desires us to state "the failures and causes of the enclosed prints," which are reduced copies of a card portrait. If the original be good, the first failure arises from under-exposure and over-development of the reduced negative, producing a hard black and white print without detail. One of the prints is imperfectly fixed from the use of weak or old hypo, or the prints sticking together. Insoluble hyposulphite of silver has been formed in the print, which, decomposing in the light, produces the dirty brown effect.

R. G.—We do not know any one who has tried the collodion in question with the formula to which you refer; but we have heard of several who have failed with the formula.

W. C.—The enamel paper to which we referred did not, in our hands, present the drawbacks to which you refer in another sample. It did not crack if care were used; was remarkably pure and deep in the shadows, and was quite free from meanness. We have just been favoured with another sample from a correspondent in Berlin, which we hope to try shortly and report. We shall try Schering's also, when a promised sample arrives.

GEORGE LEWIS.—We should not apprehend any danger to sensitive plates placed to dry in a mahogany box, provided that the plates rest on clean blotting-paper. A coating of good varnish could not do any harm. 2. The term "good light" is very indefinite, but we should say from half a minute to a minute. A good rule for exposure with tannin plates is to give them at least six times as long as wet plates.

A. B. S. N.—In our experience, decidedly No. 2.

H. G.—Any silver in old developing solutions will be precipitated as a metallic powder, by standing. Or, if not, it may be thrown down as a chloride by adding salt.

Y. B.—We can only advise you in general terms, as it is impossible with any certainty to decide without personal examination as to the best mode of arranging the blinds. Primarily, all your pictures are considerably under-exposed and over-developed, giving simply black and white results. Lack of detail is the result of under-exposure. In the next place, your light is too much directly in front of your figure, which destroys relief and modelling. Get your light a little more from one side than the other; use a collodion containing more bromide and expose longer. The colour of your background is good; that of the curtain may possibly answer, but is scarcely what we should select.

X. Y. Z.—If the specimen sent be a fair sample of your work, we should imagine that you will have little difficulty in obtaining an engagement as operator. The amount of remuneration will necessarily depend much on circumstances. The salary of a competent operator in London varies from two guineas to five guineas a week. The posing, lighting, modelling, and printing, of your print are all good. It only fails a little in definition. The tone is slightly inky.

J. L. F.—Print deeper, and tone deeper if you wish to secure black tones. But your negative is scarcely vigorous enough for that purpose. With a weak negative use a Rive paper; with a hard negative use Saxe paper. The pose is somewhat stiff.

SOL.—The same sensitizing and toning baths which you use for albumenized paper may be used for resinized paper. Mr. Cooper recommends a strong silver bath, with the addition of a little alcohol. See his paper in the present number. 2. There is not usually any difficulty in obtaining purple tones with the bath of gold and acetate of soda; if you can get sepia or black tones, but not purple, it must arise from some peculiarity of the paper. 3. The addition of a little bromide to the collodion you name will probably aid you in securing half-tone.

W. A. S.—The exact time required for fixing is a point upon which some uncertainty prevails. We should regard 4 or 5 minutes as too short a time with a highly albumenized Rive paper. It is quite possible that 10 minutes may be sufficient, especially if in that time the purple tone, which had disappeared at the first immersion, has been restored. Imperfect fixation generally shows itself in a few hours, as the undissolved hyposulphite of silver left in the print by imperfect fixation decomposes very rapidly, producing a dirty yellow or brown.

ONE OF YOUR EDITORS.—A bromo-iodized cadmium collodion is best suited to a hot climate both for keeping qualities and excellence of general results. Develop with iron and intensify if necessary. 2. A similar collodion, but containing a somewhat less proportion of pyroxaline and iodide, is good for positives. A little of an alkaline iodide, say ammonium, is also of some advantage. For positives the free use of tincture of iodine in the

collodion is generally an advantage. See collodion formulas in our YEAR BOOK OF PHOTOGRAPHY, 3. There is no danger in taking ether or collodion a voyage through the tropics, if they are properly packed. The bottles should not be more than three quarters full so as to allow for the expansion of their contents. They should be well stoppered and tied down, and securely packed to prevent breakage.

FREDEBICK BARTON.—We are much charmed with your copies of etchings; their effect on the resinized paper is extremely pleasing. The copy of Bertalozzi's engraving is very successful and very beautiful; the peculiar tone is admirably reproduced. Your difficulty in obtaining black tones with the resinized paper is somewhat an anomaly, as any complaint of the tone which has reached us has generally been of too great a tendency to run into the black tone.

W. L.—The wind either in open air portraiture or landscape photography is a sad enemy to the photographer: we are afraid we cannot suggest any means of circumventing it. We are glad to hear of your success with the new developer. Report on your glass in our next.

EXCELSIOR.—Judging from the character of the street view, we should say the fault arises from excessive over-exposure, destroying all contrast. The mixture of the collodions in question produced a sample much more sensitive than you had been working with. Try reducing the exposure very considerably, and let us know the result. 2. A slight amount of discoloration in your bath for exciting paper will not do any harm. It is easy to remove the colour when it gets too deep, using either a little of a solution of citric acid or chloride of sodium, if you have not kaolin at hand. Do not add ammonia to a bath which has been some time in use.

J. W.—See preservative process by Mr. Blanchard in our YEAR-BOOK OF PHOTOGRAPHY for 1863, also at p. 578 of our last volume.

A. & S.—The marbled mottling on the paper sent is very like what occurs in the use of a silver bath nearly exhausted. We have seen a similar result arise when, from some cause, the surface of the paper was repellent, and had not sufficiently long floating. Perhaps the most probable cause is one which sometimes occurs when several sheets of paper have been excited without disturbing the solution, the upper stratum of which gets robbed of its silver, whilst the stronger solution, having a greater density, remains below; a very slight agitation will of course restore the balance; but under some circumstances that agitation is necessary.

S. X.—We cannot with certainty state the cause of the light spots in your print. They look like the result of contact with an acid before the hypo was entirely removed. 2. The abraded marks on the albumenized paper have certainly the appearance of having been done purposely. An albumenizer informed us that such marks were not unfrequently found on the paper before albumenizing. The dog is very good, with the exception of the slight movement of the eyes. The lady is lighted a little too directly from the front to secure sufficient contrast and modelling.

G. PAARKING.—See answer to A. M. in our last.

FAITH.—Use white blinds to regulate the amount of light from roof and left side, and white screens to get reflected light on right side. Avoid too free use of top light. See article on Glass House in our ALMANAC for this year.

TYRO TANNIN.—The use of simply bromized collodion has not been common, but it has been tried. Mr. Crookes experimented with it some years ago, and we think also Mr. Berry. It is not usually supplied by any maker; your best plan will be to get plain collodion, or make it, and add bromide of cadmium about four grains to each ounce. Major Russell has not yet entered into specific details. For development try one grain of pyrogallic acid, and from one to two grains of carbonate of ammonia in an ounce of water.

J. BERGESS.—Mr. Cooper, to whom we sent your sample of paper, has occasionally met with a similar result, where the paper has from some cause repelled the silver solution. He recommends as a safeguard the addition of a little alcohol to the silver bath. See his paper in the present number.

J. P.—Registered photographs are not required to be specially marked, and every person vending a copy, in any form of a copyright photograph, is liable for his own act, and risks incurring penalties. We can readily conceive that the subject may cause serious trouble to manufacturers sending out goods in boxes ornamented with photographs, as it may easily happen that they may unconsciously be selling pirated copies. The law does not recognize ignorance of its enactments as any justification in case the law is broken, nor does it recognize ignorance of the ownership of property as a justification in case of appropriation. A person who, therefore, appropriates a right to copy a photograph, simply because he does not know that any one has a property in it, does so at his peril. In order for any one to have a right to copy, he must first ascertain, at the cost of whatever labour or effort may be necessary, that he does not infringe the rights of others. A simple plan would be to inquire of the original photographer, or to pay the proper fee and examine, at Stationers' Hall, the Registrar's list. This may be troublesome, but it is honest and safe. We shall, probably, have more to say on the subject shortly.

W. B.—Mr. Wood will have pleasure in explaining any special point regarding his transfer process, respecting which you may desire information; if you will specify your wishes.

A. WOOD.—We shall be glad to receive and try some of the prepared paper you kindly offer. Your first letter was, as you conjecture, received too late for insertion that week.

N. JOCELYN.—Thank you for your communication and samples of paper. Both shall receive attention in our next. Several correspondents in our next.

Photographs Registered during the Past Week.

- MR. THOMAS FALL, Market Place, Bedale, Yorkshire,
Two Photographs of "Anderson," of the "All England Eleven."
MR. WILLIAM PRESTON CAULTON, Horncastle,
Two Photographs of the Rev. Charles Prest.
MR. ANDROSE COPSEY, Long Melford, Suffolk,
Two Photographs of Clare.
MR. JOHN JAMES WILSON, 22, High Street, Eton, Bucks,
Photograph of Mr. William Leggatt.
MR. ROBERT KNOTT, Bolton-le-Moors, Lancashire,
Photograph of the Rev. Thomas Sneyd Wallace.

THE PHOTOGRAPHIC NEWS.

Vol. VII. No. 242.—April 24, 1863.

CONTENTS.

	PAGE		PAGE
Nature Printing and Photography.....	193	On the Decomposition of Collodion. By Dr. Van Monckhoven	198
Bromides without Iodides in the Tannin Process.....	193	The New Art of Auto-Typography. By George Wallis	199
Strange Discovery—Pre-Daguerreotype Photographs	193	Correspondence.—Foreign Science, &c.	200
Enamelled Paper for Card Portraits	195	Proceedings of Societies	201
Photogenic Action at Different Altitudes	195	Photographic Notes and Queries	203
On Development with Formic Acid. By Dr. Monckhoven	196	Talk in the Studio	203
Enlarged Photographic Transparencies for Ornamental Windows, &c. By Dr. Taylor	197	To Correspondents.....	203
		Photographs Registered during the past Week	204

NATURE PRINTING AND PHOTOGRAPHY.

Our readers will find on another page an interesting paper on the "New Process of Auto-Typography" read by Mr. Wallis at a recent meeting of the Society of Arts. We wish to call the attention of experimental photographers to the details of the process, and also to add one or two suggestions as to the possible combination with this process of photography, so as to produce from the photographic negative engraved plates in relief or intaglio, as described by Mr. Wallis.

Mr. Wallis's process, as will be seen, is analogous to that known as "Nature Printing," by which impressions of natural objects are obtained on metallic plates, and the down of a feather or the frond of a fern, are made to yield their forms to plates capable of being printed in the usual way. Many photographers have observed that the collodion negative presents definite relief, the deposit on the high lights often being palpably higher than the deep shadows. Mr J. W. Osborne has actually produced metallic impressions of such relief by placing upon the negative a piece of tin foil and submitting it to the pressure of a rolling press. It is true that hitherto the relief has been chiefly observed in subjects possessing strongly marked contrasts, such as copies of line engravings, &c., but it may be fairly assumed, although it may have been appreciable only in such cases, that the relief doubtless exists in absolute relation to the gradation of the negative. It is observable, moreover, in a much more marked degree in some negatives than in others, in cases for instance where a considerable amount of silver has been piled on in the process of intensifying, and also in negatives submitted to the continued action of bichloride of mercury for a few hours, in which case a considerable deposit of mercury is secured.

The question then arises, Can a negative be obtained with a deposit to produce mechanical relief in a sufficiently marked degree to be capable of yielding a printing image after the fashion described by Mr. Wallis? We think it is by no means impossible or even improbable. It is at any rate a question worthy of careful consideration, and we again recommend Mr. Wallis's paper to our experimental readers.

The methods of obtaining relief with the bichromates in combination with gelatine is already known, and it may be worth consideration, whether Mr. Wallis's method might not be found useful in connection with this process.

We learn from the interesting report of the proceedings which followed the paper, in the *Journal of the Society of Arts* that plates were actually produced during the course of the evening and printed by a copperplate press, the impressions being distributed amongst the auditory, proving at once the simplicity, rapidity, and efficiency of the process.

BROMIDES WITHOUT IODIDES IN THE TANNIN PROCESS.

SINCE our brief announcement, a few weeks ago, that Major Russell had found a considerable accession of sensitiveness in tannin plates, on using a collodion salted with a bromide alone, without any iodide, we have had many inquiries as to the best bromide for the purpose, and the proportion to be used. Some ten years ago the use of a simply bromized collodion for the wet process was in considerable favour amongst many high authorities, Sir J. F. W. Herschell, Mr. Crookes, the Abbé Laborde, Mr. Berry, and others, being amongst its warm advocates. We find, on reference, that various portions, from four grains to ten grains of bromide to the ounce of collodion, were recommended, and that the bromides of cadmium, calcium, and ammonium had their respective adherents. Some years ago we tried a series of experiments with collodion prepared with four or five grains of bromide of cadmium to each ounce of collodion, but with less satisfactory results in the wet process than were produced by a mixture of the bromide and iodide.

Major Russell, seeing our reply to a correspondent on this subject, kindly furnishes us with the following hints for the guidance of our readers:—

"DEAR SIR,—In the 'Answers to Correspondents,' I see that you recommend the trial of 4 grains of bromide to the ounce of collodion; I do not think that this will be sufficient: the formula which I find to answer best is:—

Pyroxyline (which will make a quick-setting collodion)	5 grains
Bromide cadmium	8 "
Alcohol '805	3 drachms
Ether	5 "

Excite in a 60-grain bath saturated with bromide, and keep in fifteen or twenty minutes; this will make a very creamy film. The bromide will not burst out if used in much larger proportion, but may prevent the setting of the collodion, if not of a quick-setting kind.—Yours truly,

"RUSSELL."

STRANGE DISCOVERY—PRE-DAGUERREOTYPE PHOTOGRAPHS.

A STRANGE discovery, of peculiar interest to photographers, has been the subject of conversation in scientific circles for some short time past. It is neither more nor less than the exhumation from a pile of old papers, &c., of several photographs alleged to be of a date at least half a century prior to the supposed discovery of the art. They consist of sun pictures on silver plates, much resembling the early daguerreotypes, and of paper pictures unlike any photographs of which we have at present any knowledge. We have been favoured with a sight of these sun pictures and with many interesting particulars of their history; but in deference to the wish of the gentleman who has charge of the subject, we refrain from any statement of details at present. The gentleman to

whom we refer has been for some time collecting historical and other evidence on the subject, and hopes shortly to be able to present not only a clear case establishing the production of the pictures in the eighteenth century by James Watt or his partner Mr. Bolton, but also to publish some account of the method employed. Until his case is perfect to his own satisfaction, he naturally deprecates discussion of the subject. We are promised the earliest intelligence of full and accurate details, and we refrain, therefore, from giving further particulars than have already appeared in print, the whole of which we may add may not be quite exact. The first published account of which we have any knowledge appeared in the *Birmingham Daily Post* of the 16th inst., from which we subjoin a somewhat lengthy extract. Before doing so we give a more summarised extract from last week's *Reader*, as follows:—

Photography, there is ground, it seems, for thinking, is not so recent a discovery as has hitherto been supposed. It is said that James Watt had an inkling of it, as of so many other things, seventy or eighty years ago. Among the household lumber of the family of Bolton, Watt's partner, a silvered copper-plate has turned up—now in the Patent Museum of Kensington—having on it an impression of the old premises of Watt (or Bolton) at Soho, Birmingham. The impression represents the old house as it was a long time ago, not as it now is, or has been within ordinary recollection; and those who have seen the plate have no doubt of its being, in some way, a photograph. Whether it may not be a photograph recently made from some old drawing or engraving is worth inquiring; but authorities are disposed to think it is not. Moreover, there exists traditional evidence of some sort of experiments that could now be called photographic, in which Watt, Bolton, Priestley, and others, belonging to a so-called Lunar Society about Birmingham, were engaged. An old man of ninety (recently dead or still alive), recollected, or recollects, that Watt and others used to take portraits of people in a dark room; and there is a letter extant of Sir Wm. Beechey, a portrait painter or artist of those days, begging the Lunar Society to desist from these experiments, as, were the process to succeed, it would ruin portrait-painting.

The following is from the *Birmingham Daily Post*. It is, perhaps, necessary to premise that the speculations on the subject, although interesting, are the writer's own, made without a full knowledge of all the circumstances, and must be taken *quantum valet*:—

There is an art called photography, which has hitherto not been connected with our town, excepting by its practice. In this respect, however, Birmingham is but on a level with the rest of the world; for the practice of this art is co-extensive with human vanity. We think, however, that Birmingham must now figure in the history of this beautiful art, and that, too, in a way which will probably clear up some of the dark passages in the course of photographic discovery.

A distinguished chemist in London, writing a few days ago to a friend of his in this town, says:—"The following extraordinary fact will interest and surprise you. Yesterday I was at the Patent Museum, and inspected some recent additions obtained from lumber, formerly in the possession of the Boulton family. I saw two copper plates, plated with silver by the old process. They had been carelessly kept, face to face, and are much scratched. On one is a photographic image of the old house at Soho. It has been ascertained that the house was altered at a certain date, and that the image in question is of the house *before* the alteration. This was produced by James Watt! There are also many paper photographs which were produced by J. W. Further, distinct evidence has been got to show that J. W. was engaged in photographic experiments, and that he took portraits. There was a society in Birmingham called 'The Lunar Society,' comprising amongst its members Watt, Wedgwood, Priestley, and others. A letter was written to this society by Sir William Beechey (or Beachy), the portrait painter, expressing a hope that the then photographers would not disclose their process lest the art of portrait painting should come to an end. There is much other collateral information on this curious subject which has been procured; and inquiries are being still prosecuted. You may probably aid in the investigation. The information is so startling as to seem almost incredible; yet it is true. Of course iodine could not have been used, as it was not then known."

Let us see how this strange discovery bears on the history of

photography. It seems but the other day that we were startled by the announcement that a Frenchman had exhibited to the *savans* of Paris beautiful pictures, mostly architectural, produced in the camera obscura, upon plates of silver or plated copper. The announcement was a surprise to the civilised world, and France purchased the secret of his process from Daguerre, and presented it to the country. The process, when disclosed, turned out to be in brief, the following:—A plate of silver or plated copper was carefully cleaned and polished, and exposed for a short time to the vapour of iodine. It thereby became coated with a film of iodide of silver. This plate was exposed to the luminous image of the camera, and an impression was produced upon it, not visible to the eye, but made evident or developed, by exposing the plate to the vapour of mercury. The picture was fixed, or made permanent, by being washed with a solution of hyposulphite of soda, by which the film of iodide of silver was removed and all sensibility to light destroyed. This beautiful process, although now superseded even in France by the invention of our countryman, Mr. Fox Talbot, was the first really practicable photographic process; the first, that is, available for general use. Its results, moreover, are of astonishing beauty.

It has long puzzled the student in photography to account for Daguerre's invention. He does not appear to have been a man of other than very humble scientific attainments, and his subsequent contributions to photography were puerile and worthless. By what course of thought or experiment was he led to this singular process? He never gave any information on the subject. He died and "made no sign."

This discovery relative to Watt's experiments, added to what Niépce had done prior to Daguerre's invention, seems to bridge over the difficulty very satisfactorily. If it be granted that Daguerre had learned what Watt had done (and the known intercourse of the Birmingham *savans* with their Parisian *confères* renders this probable), the course of Daguerre's researches seems very plain. Let us recall the facts that Daguerre had never devised any photographic process until after he had entered into partnership with Niépce, that Niépce had invented a good but slow process, and that it was not till after Niépce's death that Daguerre's process was invented. Niépce's process was this; he spread upon a sheet of black glass a varnish made by dissolving bitumen in oil of lavender. This plate was exposed in the camera, when the portions of the hardened varnish on which light had acted, were bleached and made insoluble. The faint image produced was strengthened by plunging the picture into oil of lavender, which was absorbed by the unchanged portions of the bitumen, which were either dissolved off or made more transparent, and the picture was strengthened by the more perfect expression of the black glass constituting the dark parts of the picture. Subsequently Niépce exposed the picture to the vapour only, of the oil of lavender, and obtained the requisite vigour.

The points of similarity between Niépce's and Daguerre's process are striking; the use of a surface which, by its blackness (the black polish of the silver), constituted the dark parts of the picture, the coating with a film acted upon by light, the developing or strengthening the impression made, by subsequent exposure to a vapour. When Watt's experiments were made, iodine had not been discovered; and, it is to be presumed, that his silver plate was coated with chloride of silver, the only silver salt then known to be powerfully affected by light. Subsequently iodine was discovered—an element belonging to the same natural family as, and exceedingly analogous to, chlorine. Moreover, it had been put on record by an English chemist, that iodide of silver produced in the moist way was exquisitely sensitive to light (although the necessary conditions of its sensitiveness were overlooked). With all these facts, which were known at the time, and which, it may be readily supposed, were collected by so enthusiastic an inquirer as Daguerre, a man whose devotion to his hobby very nearly procured for him a place in a lunatic asylum: with these facts the construction of his process becomes very easy. A silver plate exposed to the newly-discovered iodine, instead of being treated with chlorine, as practised by Watt, would produce the compound iodide of silver, already known to be more sensitive than the chlorine. But on making the experiment of exposing this plate in the camera, Daguerre must have found that no image was produced; yet iodide of silver made in the moist way was highly sensitive, and the iodide of silver made in the dry way could hardly be believed to be wholly insensitive; there would, doubtless, be an impression, although not visible. But

Nièpce had shown how very feeble pictures could be strengthened by exposure to vapours which would act on the sensitive surface. What more natural than that Daguerre, before abandoning the iodide of silver, should assure himself, either that there was or was not an impression produced on the plate, by exposing it to the influence of something which would attack it, and which might be supposed to attack it differently in different parts, if the light had really produced any change in the nature of the film. Had he pursued this course of thought, he would inevitably be led to think of mercury, which so readily amalgamates with silver. Had he applied a dilute solution of proto-nitrate of mercury, he would have found a picture present itself, but he does not appear to have tried this. The example which Nièpce had set him of applying a vapour was the method he resorted to, and, as is known, with a success at which he himself must have been startled.

But we must not pursue the subject further. Whether the production of pictures on silver by Watt was ever published, we do not know; probably we soon shall know. If it was not, his doings were certainly known to his scientific brethren, some of whom were in correspondence with French savans, and were members, as we believe he was, of French learned societies. But for the length to which it would prolong these remarks, we should have liked to dilate somewhat fully on what we must only note very briefly—another aspect of the curious discovery made respecting Watt and his photographic experiments. Our readers must have heard of photographs having been obtained in colours; that is, pictures in which not only the light and shade, but the colours of natural objects are reproduced. These results, obtained principally by the researches of M. Nièpce de St. Victor, are produced upon plates of silver, coated with chloride of silver, the film of chloride of silver being produced by electrolytic action, and afterwards heated. Such a film will take the colour of any ray of light which may be for a time allowed to act upon it. How little did Watt suspect, when he was experimenting with his chloride of silver plates, that in a few years these same plates, prepared by a somewhat different process from any he could have employed, would hold themselves ready to take any tint of the rainbow, which may be allowed for a time to fall upon them!

ENAMELLED PAPER FOR CARD PORTRAITS.

We have pleasure in publishing a letter just received from one of our esteemed correspondents, Mr. H. Jocelyn, secretary to the British Embassy at Berlin, in which some further details are given regarding the new enamelled papers, with details of the manipulation. The communication was accompanied by some very finely toned specimens, and some samples of the paper in question, in regard to which we may add one or two words. The paper received from Mr. Jocelyn possesses a much higher surface than that to which we recently referred as having been received from Herr Liesegang, and is of a thicker substance. Contrary to the suggestion of our correspondent, we excited it on a 50-grain bath, which we had in use, and had no difficulty in obtaining brilliant results, which toned well and were in all respects satisfactory. The chief difficulty is the tendency to crack, and that may be obviated by the method pointed out in the subjoined letter.

Regarding the paper we have already tried, we think our correspondent is in error as to the nature of the enamel. Sulphide of ammonium gives no indication of the presence of lead, nor did we find any tendency to greyiness in the toning; the tints we obtained varying from warm sepia to a rich purple black. Whether it be prepared by Schering or not, we do not know, as we have not yet received a promised sample by which to make the comparison. From a sample we have seen of M. Schering's preparation, we think it is probably similar to Herr Liesegang's, if not the same. We append the letter.

"DEAR SIR,—I have been so long a reader, and I hope a profiter by your valuable periodical, that I venture to send you herewith a specimen of the enamelled albumenized paper, which I do not think you can already possess. I observe you mention having received some from M. Liesegang, at Elberfeld. The paper which he uses he derives, I believe,

from the manufactory of M. Schering, of this city, and that paper is enamelled, as it is pretty well ascertained to be, with a preparation of lead, which always gives rise to a certain greyiness when in contact with hyposulphite of soda.

"The specimen I send you herewith is prepared by another manufacturer of this town.

"The enamel in this case is not a preparation of lead, but as it is a trade secret, of course it would not be for me to say of what it consists. You will see by the enclosed couple of prints how exquisitely delicately every detail in the negative is reproduced on the enamel, and how far superior it is for card portraits and stereoscopic slides to the albumenized paper.

"Its use is not unattended with difficulties, and, considering the wholesale manner in which our photographers of cartes de visite print their negatives, I fear it will be some time before it is adopted by many of them.

"In the first place, the silver bath should be made of 1 in 5, or of nearly 96 grains to the ounce, in order to obtain the most brilliant effects. It should be of pure recrystallized nitrate, and not the concentrated refuse of old nitrate baths, as I have learnt to my cost, in which case it will not tone at all.

"The enamel paper must never be rolled up, but be always kept in a flat portfolio, or it cracks all to pieces.

"An arrangement must be contrived to prevent it from curling when drying, either by straining it in a light frame of wood, or, what is more simple, by having two strings stretched across the room exactly parallel and one above the other, at the distance from each other of the width of a sheet of the paper to be sensitized, which is then easily kept strained while drying by four clips instead of two at the four corners of the sheet.

"It should not be silvered long, as the solution saturates the albumen on the enamel almost immediately.

"I always tone with gold and a solution of borax used warm, about ten grains to the ounce to each grain of gold.

"It tones rapidly, producing the colours of the enclosed.—I am, dear sir, very faithfully yours,

"NASSAU JOCELYN,

Secretary to the Embassy.

"British Embassy, Berlin, April 10, 1863."

A further letter, after some remarks on the identity of Schering's and Liesegang's paper, adds:—"You must be careful in pressing the cards when finished. They must pass over a steel plate, and not only between rollers, which would crack the enamel."

PHOTOGENIC ACTION AT DIFFERENT ALTITUDES.

MR. GLAISHER, who has recently resumed his balloon observations, in his last ascent made some photographic experiments in illustration of the amount of actinism at different altitudes, presenting very curious results largely at variance with those obtained by Mr. C. Piazza Smyth on Teneriffe. Mr. Glaisher, in a communication to the daily press, says:—

"For the purpose of learning something of the action of the chemical rays of light, I took slips of sensitized photographic paper, having arranged that similar slips, made at the same time, should be exposed at the Royal Observatory, Greenwich, and the amount of coloration in one minute noted every five minutes, so as to have some simultaneous observations with the experiments I might be able to make in the balloon. The paper in the balloon was exposed to the full rays of the sun, and with this remarkable result, that when above three miles high the paper did not colour in half an hour so much as it did in the grounds of the Royal Observatory in one minute.

Whilst Mr. Glaisher finds that the actinism on *terra firma* at Greenwich is thirty times greater than it is at an altitude of upwards of three miles, Mr. Piazza Smyth, in his Teneriffe experiments in 1857, found a progressive actinic intensity with each increase of altitude. "The average times," he

says, "of getting a good picture of a standard subject, in average illumination, were represented by 7 at the sea level, by 5 at the 8,900 feet station, and by 3 at the 10,700 feet station." Possibly varying temperature and other conditions may have affected the results in some degree. Of the temperature on Saturday last, Mr. Glaisher observes:—

Just before leaving the earth the temperature of the air was $61\frac{1}{2}$ deg. At the height of one mile the thermometer read 41 deg.; but we had passed up so quickly, that it is most likely that this reading was higher than the true temperature. At the height of two miles the reading of the thermometer was 32 deg.; at three miles the temperature was 21 deg.; at four miles 16 deg.; and at the highest point reached was 12 deg., which was the lowest temperature we experienced.

The results generally confirm the law as found by the combination of all the preceding experiments, viz.: That the theory of a uniform decrease of temperature with elevation must be abandoned.

The air was dry before starting, and, as found in all the preceding experiments, was very dry at heights exceeding four miles.

Clouds were reached at the height of one mile, and on passing above them, the sea of shining white clouds extending to the horizon, was, as usual, very fine.

The following paragraph from Mr. Glaisher's letter will interest some of our readers:—

From 2.15 to 2.31 I devoted myself almost entirely to observing the black lines in the solar spectrum; between these times the balloon was revolving once in five minutes. I succeeded in adjusting the slit of the apparatus to the sun, and kept my eye to the telescope whilst the balloon completed three revolutions. When the light entered the slit from the sun itself the lines in the spectrum were innumerable. All those I saw before leaving the earth were visible, and many more. The nebulous lines (H) were both seen, and the spectrum a good deal lengthened at the violet end. At the red end (A) was visible. When the light came from the sky in the immediate vicinity of the sun the spectrum was shorter, but all lines were visible from (B) to (G). On passing from the sun the spectrum shortened very quickly, and when opposite to the sun there was no spectrum—in fact, no light at all.

The courage and perseverance with which Mr. Glaisher, whom our readers will be proud to remember is an ardent and accomplished photographer, prosecutes these ascents for scientific observations is worthy of all admiration. That it is not by any means devoid of danger, and that it demands high courage and great self-possession is abundantly proved by the events of the last ascent, to which only the skill of the aeronaut and the calm presence of mind of all concerned prevented a disastrous termination. The ascent commenced from the Crystal Palace at 1.17 p.m., and the earth was reached again at 2.50 p.m., at Newhaven, on the south coast. The entire distance of nearly sixty miles, in round numbers—we do not speak by the card—besides the ascent and the descent, being done in about an hour and three-quarters, and a descent in the sea being only barely escaped. We append the exciting account of the descent:—

After reaching the height of four miles, and we had determined we were moving directly towards the coast, Mr. Coxwell continually applied to me for the readings of the barometer, and directed our companion, Mr. I——, to keep a sharp look-out for the sea.

Immediately after we attained an elevation of four and a half miles Dr. Coxwell let off some gas, and said he felt assured there was not a moment to be lost in getting within view of the earth.

Mr. Coxwell again let off gas rather freely, so that we descended a mile in four minutes.

At 2.46 we were two miles from the earth, the barometer reading 21.20 inches, when Mr. Coxwell caught sight of Beachy Head, and exclaimed, "What's that?" and then the coast through a break in the clouds, and exclaimed, "There is not a moment to spare, we must descend rapidly, and save the land at all risks." It was a bold decision, but we were in a critical position, and I do not see what else could have been done.

Mr. Coxwell now used the valve with a degree of freedom which would have alarmed any one who had not perfect confidence in his skill.

I was requested to pack up my instruments as quickly as possible, and then to assist in getting ready a large amount of ballast to throw away at the last moment.

On breaking through the clouds we appeared to be already over the water, but as the ground came up to us, or seemed to do so, we found there was land beneath. Mr. I—— rendered important services in letting up the neck lines, and in clearing the ballast for immediate delivery, so as to lessen the violence of the descent.

When orders were given to put out sand, we did so simultaneously, which gave a favourable check, and, as the lower part of the balloon itself assumed a parachute form, the shock was not so bad as might have been expected. Most of the instruments were broken, owing to their delicate construction, yet, strange to say, the glass vessels of air, collected at the highest point for Professor Tyndall, remained uninjured, as did some bottles of lemonade which Mr. Coxwell had placed in the ear.

We descended the last two miles in four minutes, and had we done so less rapidly the land would have been missed altogether, and we must have fallen into the sea. The descent was within half a mile of the station at Newhaven.

ON DEVELOPMENT WITH FORMIC ACID.

BY DR. MONCKHOVEN.

I HAVE prepared formic acid in the following manner:—I kept a mixture of glycerine and oxalic acid for three days in a glass retort at a temperature of 220° to 230° F. The crude product of distillation was treated with soda, and dried in order to free it from the glycerine and other volatile substances, carried over during distillation. The formiate of soda thus obtained was treated with sulphuric acid, diluted with half its volume of water, and heated in glass retort furnished with a condenser. The formic acid obtained possesses a penetrating odour, is perfectly colourless, and marks 1.12 with the densimeter, and is a very concentrated acid.

I then prepared two samples of pyrogallie acid, exactly following the proportions indicated by M. Claudet, viz.:—

Water	225	parts.
Alcohol	20	"
Formic acid	30	"
Pyrogallie acid	1.20	"

The second sample was prepared in exactly the same manner, except replacing the 30 parts of formic acid by 30 parts of dry crystallized acetic acid.

Lastly, I prepared a bath of iron also according to the usual proportions, viz.:—

Sulphate of iron, quite pure	...	5	parts
Water	...	100	"
Crystallized acetic acid	...	2.5	"
Alcohol	...	5	"

I then compared the development of plates exposed in a stereoscopic camera with compound lenses, furnished with a spring cap. I exposed eighteen plates in succession; the weather was very favourable, as I operated under a cloudless sky.

The result of my experiments is as follows:—

1st. That sulphate of iron admits of a shorter exposure in the camera than pyrogallie acid, whether the latter contains formic acid or acetic acid.

2nd. Development with pyrogallie mixed with formic acid is not more rapid than when acetic acid is added to it.

3rd. The negative developed with pyrogallie acid mixed with formic acid appears quick, but the formic acid tends to reduce the silver from the nitrate, and to produce on the film a grey deposit of metallic silver. I believed, upon a superficial examination, that there was greater intensity of the picture, but an examination by daylight by transmitted light satisfied me there was not.

My own opinion upon this point is as follows:—

1st. That formic acid alone, without pyrogallie acid, in

not causing the image to appear by reducing the silver from the nitrate, produces a veil which gives to the iodide of silver a grey colour.

2nd. That formic acid added to pyrogallic acid, acts in the same manner, and that the exposure in the camera is the same as with the ordinary formula.

These experiments were made on the 2nd April, with two nitrate of silver baths, the one neutral, the other acidified by nitric acid.—*Le Moniteur de la Photographie*.

ENLARGED PHOTOGRAPHIC TRANSPARENCIES FOR ORNAMENTAL WINDOWS, &c.

BY DR. TAYLOR.

[We are favoured by Dr. Taylor with the following excellent remarks on the capacity and scope of photography, and especially as to its probable future position in decorative art, which were made at the last meeting of the Glasgow Photographic Association on the discussion on Mr. Macnab's interesting paper on "Copying and Enlarging."]

DR. TAYLOR said that the paper which had just been read, related to a subject which to him appeared to be of great interest to photographers at the present time. He believed that photography could not be said to be in its infancy in the sense in which some persons used the term, because he thought that it had reached very considerable maturity; so much so, that, in some respects, comparatively little remained to be accomplished. They had already reached results so beautiful and so nearly perfect that he feared the strides to be made in future years would not, in regard to some walks of the art, be so great as those of the past. Confident expectations were frequently expressed regarding the probability of getting the pictures in the natural colours; he confessed that in this direction he had little hope. From the nature of the chemical processes employed few colours could be imitated in the film. How, for instance, were they to give silver the substance at present forming the image, all the varieties of hue assumed by natural objects. As long as the picture consisted of a silver deposit he had no hope of seeing any other colours than those which can be assumed by silver. The same remarks may apply to any other single substance which might be substituted for silver; in fact, he could not see how it was possible to get the infinite variety of natural tints in a photographic picture, and the mere power to imitate a few colours would be of little value. But as to future advancement, he was very sanguine in the progress of the art in another direction, viz., as regards the size and boldness of effect of the pictures. They were all well aware that the art of the painter would be confined in its results if it were limited to miniatures or to cabinet-sized pictures. It was only in large gallery paintings or in great dramatic pictures, as seen in churches and other public buildings, that the art gained power to make its deepest impressions on the mind. The painted ceilings became a part of the architecture, and produced an effect on the spectator which could never be obtained by small work. Photography had been hitherto confined to small work, such only as could be seen by close inspection, and dependent for its effect on minutiae of detail, and it was only very recently that it had attempted to reach a grander development, and to produce results which large size and breadth of effect alone could give. The processes of enlargement, which had been that evening so well described, sought to produce such work that no one could pass it without being impressed with its presence. It would now seem that small pictures, such as those exquisite little cards or stereoscopic views now so well known, can be enlarged to almost any extent. No one could doubt but that this was a great step in advance, and that photography would thus be enabled to take up a more extended, and perhaps a higher position. Those transpa-

rencies, such, for instance, as the one before the meeting, would come to be taken advantage of for the decoration of buildings. The house-painter at present exercised his faculties in decorations of this kind, and so long as he confined his efforts to ornamental scrolls or geometrical patterns, succeeded moderately well; but when the human figure or other object, requiring accurate and subtle drawing, was attempted, the results were too often anything but beautiful or instructive. Drawing was an art in which few obtained perfection, but photography promised to bring a higher kind of decorative art within easy reach. If glass doors and pannels could be ornamented with large sized photographs of appropriate subjects, he had little doubt that they would soon supplant the daubs that at present too frequently appear in such situations. Then, again, as regards our stained-glass windows, he thought photography would yet have an important part to play. The kind of art at present in use was excessively costly, we paid thousands of pounds for it. He would not wish publicly to say anything by way of depreciating works which were so highly paid for, and on which so much labour had been bestowed, but to a society of photographers the case was different, and to them he would confess, that, in his opinion, such works, compared with photographs, were, in most instances, merely barbarisms. In past ages, no doubt such work served its purpose, and as a relic of the past it deserved our regard; but he had no doubt but that appropriate photographic transparencies of well chosen subjects, delicately tinted by coloured glass placed behind them, would be far more effective and beautiful than the incongruous and improbable-looking pictures at present too often seen occupying prominent situations. Let us have such pictures to take the place of the frequently ill-drawn and glaringly-coloured figures which had long been the representations on stained glass. Colours were much alike in all ages, and though the scenes represented were long past, this ought to form no reason why the pictures should be made of such hues and arrangement as to have only a faint resemblance to anything that ever could exist, or that modern art should still be tied down to imitate the colours and designs of a past age. The fact seemed to be that glass painting was an art which, as we had borrowed it from our ancestors, we were afraid to improve through dread of innovation. We have it from antiquity in the same way as we have received the symbols of heraldry, and as relics of antiquity we tolerate or even venerate them, but as for the received system of decoration on windows he confessed that he would rather see it among the dust and cobwebs of an old church than as a thing to be imitated or followed at the present time. But the question for us is, could photography do better? He had tried the fine head of Tenyson with tinting of colours and surroundings of coloured draperies of stained glass, and he thought the effect much finer than with the conventional heads employed by the glass-stainers. As to the landscapes, he had hopes that they would soon be produced of such a size as to be seen at once by a whole company of spectators; they would then, if executed with all the precision, multiplicity of detail, and truthful interest which photography could give them, and if made of such dimensions as to cover the end of a good-sized room, become among the grandest achievements of any art. To look at them would, indeed, be next to travelling to the spots which they represented. The process by which this enlargement could be produced had to him a peculiar interest. The first specimen of its results was one executed a few years ago by the author of this paper. He was anxious to possess a large photograph of Holyrood Chapel, but no such picture had been taken. Mr. Macnab got hold of a paper stereograph of the required subject, and by the process they had this evening heard described, soon succeeded in producing the enlarged picture which some of them had lately seen in the dioramic apparatus. It was most successful, every detail was faithfully reproduced and without visible distortion, giving

great promise as to the future results to be expected from this process of enlargement, which he could not but regard as one of the most fertile fields for the future enterprise of photographers.

ON THE DECOMPOSITION OF COLLODION.

BY DR. VAN MONCKHOVEN.

If there exists a subject upon which numberless gratuitous hypotheses have been written, it is surely this. To prove it, let any who is thoroughly acquainted with chemistry take any bulky treatise on this science, and turn to the pages upon which ether and alcohol are described; he will read that iodine and bromine act at high temperatures upon these substances, producing others, the names of which are very sonorous, and, by the aid of the imagination, very long articles are written upon the decomposition of collodion, which have a very learned aspect, but which, in fact, make true chemists smile, for they contain all sorts of things except the truth.

Some years ago, when the nature of collodion was less known, we fell into the same error as that described, but now that more exact and complete studies have guarded us against the vagaries of imagination, we have adopted the principle of admitting facts only when they are based upon experiment, which, in a scientific point of view, is always a prime necessity. We will, therefore, now examine the decomposition of collodion, sustaining ourselves upon precise and irrefutable experiments, and not upon suppositions more or less specious.

What is collodion? It is a solution of pyroxyline in pure alcohol and ether, to which an iodide is added. It is generally remarked, that collodion, composed with pure materials and recently prepared, yields, a few days after its preparation, results very different from those obtained when this collodion has been kept a very long time—several months for example. These differences are as follows:—

New collodion gives in the nitrate bath a white film, the opacity of which is considerable, and the rapidity of luminous impression very great; but in general the pictures are not very strong (with sulphate of iron). All the details of the image come well, but the sky and strong lights in the model do not acquire much opacity.

Old collodion, on the contrary, yields films that are almost transparent, not very quick under exposure, but the pictures, on the contrary, are very intense.

There are other differences between new and old collodion, such as the following: *new* collodion, when dry, will not give pictures by washing the film after sensitizing; *old* collodion, on the contrary, does yield them. With new collodion, the picture developed with sulphate of iron is entirely soluble in nitric acid; with an old collodion, the image is not entirely soluble, which will be explained immediately.

Photographically speaking, then, there exists an essential difference between new and old collodion, and the object of this article is to ascertain the cause of this difference.

We will commence by establishing this important fact, that contrary to the generally received opinion, a collodion minus the pyroxyline, that is to say, an ethero-alcoholic solution of an iodide, will keep for an indefinite time. We possess a solution of iodide of potassium in ether and alcohol prepared many years ago; this solution is scarcely tinged with iodine, and when a little pyroxyline is added to it, it works marvellously well. This fact serves us as a basis to prove that everything which has been written upon the decomposition of collodion is erroneous; for how can traces of iodine (the quantity which colours the collodion is less than 1 gramme in 1000 litres), exercise a decomposing effect upon the collodion, when they are so feeble as almost to escape analysis.

But, on the other hand, let us take a simple collodion, consequently without an alkaline iodide, and we shall observe the following facts:—

The collodion begins by becoming more fluid, and acquires a peculiar odour of nitric ether. When kept a very long

time, it gives, when poured on the glass plate and sensitized in the nitrate of silver bath, a white film which yields pictures in the camera! And yet there is neither iodide nor bromide present!

It is, therefore, neither free iodine, ether, nor alcohol, which act in the decomposition of the collodion; it is the pyroxyline. But what takes place with it?

When the sulphuric and nitric acids act upon the cotton, not only is gun cotton formed, but also a substance greatly resembling it, which is *nitro-glucose*, as shown by Mr. Hardwich. Between *nitro-cellulose* (pyroxyline) and *nitro-glucose* (nitre-sugar), there is a very great analogy with regard to their chemical properties; but nevertheless, *nitro-glucose* produces certain effects which have escaped the rare penetration of Mr. Hardwich; they are the following:—

Nitro-glucose is obtained by mixing 300 parts of concentrated sulphuric acid with 200 parts of nitric acid, specific gravity 1.5, and 100 parts of ordinary sugar in powder. After two or three minutes' action, the plastic mass is washed in water, and pressed together with the fingers. It is then washed in warm water, dissolved in warm concentrated alcohol, and precipitated by water. After the lapse of a few days it is deposited at the bottom of the vessel under the form of a gummy mass.

The alcoholic solution of nitro-glucose, agitated with caustic potash, *browns*, and exhales an odour of *burnt sugar*. Now *simple collodion, kept several months, exhibits exactly the same characteristics.*

The alcoholic solution of nitro-glucose possesses very curious properties, the study of which is of the greatest importance to photography. This solution is colourless, and when added to collodion, it produces no effect. *It is not disturbed by the addition of an alcoholic solution of nitrate of silver.*

Kept several days in a corked bottle, the solution which was at first colourless with a purely alcoholic odour, becomes of a *rose* colour, and acquires the peculiar odour of old collodion, that is to say, of nitric ether. But more; this rose-coloured solution now precipitates nitrate of silver, and added to a recently prepared collodion, imparts to it immediately all the properties of old collodion: namely,

1. Less rapidity.
2. Very intense negatives.
3. The property of acting when dry, with a simple washing after sensitizing.
4. Transparent sensitized films.
5. Negatives which, develop either with iron or with pyrogallic acid, and not are entirely soluble in nitric acid.
6. A peculiar odour.
7. A red colour due to a little iodine set at liberty.
8. A great tendency to solarization.

Lastly, there is a fact which confirms our theory. An old collodion, prepared several years, precipitated by an alcoholic solution of nitrate of silver, instead of giving a precipitate formed only of iodide of silver, gave a precipitate six times more considerable, and the properties of this salt are *the same* as those obtained with the decomposed nitro-glucose. Doubtless this is the product which changes so profoundly the properties of collodion.

The decomposition of collodion arises then, not from the action of the acids accidentally present in the pyroxyline or ether, acids which have the effect of setting free a little iodine which scarcely changes the properties of the collodion, but from the slow decomposition of gun-cotton in presence of alcohol. Then the gun-cotton produces nitrous or nitric acid, which forms a large quantity of nitrate of ethyle (nitric ether), which ether imparts to the old collodion its well-known odour; moreover, the quantity of collodion diminishes by this fact, the solution becomes more fluid. Lastly, the product of this decomposition is an organic body of a composition hitherto unknown, but which is susceptible of forming with nitrate of silver and iodide of silver, a compound sensitive to light, both in the humid and the dry state. The developer, instead of producing upon

a film of this collodion an image composed solely of pure silver, forms, on the contrary, an image constituted of an organic substance analogous to albuminate of silver blackened by light; also, the developed picture is imperfectly soluble in nitric acid. Every one possessing old collodion can easily prove for himself the truth of the facts and conclusions arrived at.—*Le Moniteur de la Photographie*.

THE NEW ART OF AUTO-TYPOGRAPHY.

BY GEORGE WALLIS.*

As the new art-process for the reproduction of drawings to which I am about to call attention, and as far as possible describe and illustrate before you, is based in principle upon a process of an analogous character, by which certain classes of natural objects are engraved and printed, popularly known as Nature Printing, I think it desirable from my personal connection with the two gentlemen who certainly originated the direct method of Nature-Engraving, as I prefer to call it, in this country, and my knowledge of their early efforts, to endeavour briefly to correct a wrong impression which I believe to have been unintentionally given, through an imperfect knowledge of the true facts and the dates at which the first experiments were made in England.

In a paper read at the Royal Institution, 11th May, 1855, by the late Mr. Henry Bradbury, to whose ability, energy, and perseverance, the art of nature printing owes so much, and also in a more recent publication, the early attempts to obtain impressions from plants, &c., are carefully traced up. In these papers Mr. H. Bradbury gives the credit, which is evidently due to a Danish goldsmith and engraver, Peter Kyhl, of Copenhagen, as having been the first to produce impressions in metal plates direct from natural objects; but whilst honourably seeking to do justice to an ingenious man, who unfortunately died in 1833, the year in which he made his invention known, he does a certain measure of injustice to the late Mr. Richard Ford Sturges and Mr. W. C. Aitken, of Birmingham, on the assumption that the experiments made by the former in August, 1851, and the latter in the spring of 1852, were based upon a knowledge of what Peter Kyhl had done. I have no hesitation, therefore, cognisant as I am of nearly all the earlier efforts in this direction at Birmingham, to declare that neither Mr. R. F. Sturges nor Mr. W. C. Aitken knew anything whatever of Kyhl or his experiments, and did not even know that such a person ever existed prior to the publication of the paper read by Mr. Henry Bradbury at the Royal Institution, more than three years after Mr. R. F. Sturges' patent for the ornamentation of metals by pressure, which process he claimed as his invention, had been taken out.

I have felt it my duty to state this, because I purpose bringing out the true dates in connection with the invention of the process of nature printing, leading as this process does to that which I am about to describe and illustrate, and of which I claim to be the inventor.

That the Danish goldsmith and engraver, Peter Kyhl, did, in the year 1833, exhibit at the Exhibition of Industry, held at Charlottenberg, various productions in silver, decorated by a process described in a manuscript, entitled "The description (with forty-six plates) of a Method to Copy Flat Objects of Nature and Art," dated 1st May, 1833, and that the plates "represented printed copies of leaves, of linen and woven stuffs, of laces, of feathers of birds, scales of fishes, and even serpent skins," we have the authority of the late Mr. Henry Bradbury, based on that of Professor Thiele, and therefore we may accept it as a fact; but that this fact had anything to do with the experiments instituted at Birmingham, in August, 1851, by Mr. R. F. Sturges, in the engraving of lace, and early in 1852, by Mr. W. C. Aitken, in engraving skeletons of leaves, feathers, &c., by placing the objects between two plates of metal and subjecting them to pressure by steel rolls, I emphatically deny. The truth is, Kyhl's process had been evidently forgotten, and his manuscript, buried in the archives of the library at Copenhagen, was not dug up until the Imperial Printing Establishment at Vienna had given dignity to the process of nature printing, and Mr. Henry Bradbury had brought the invention from Vienna, where it was practised, and, by his skill and ingenuity, had begun to produce the works which are so worthily associated with his name.

The facts are these. In August, 1851, the late Mr. R. F. Sturges made some experiments in direct engraving, by placing pieces of lace between two Britannia metal plates, and passing them through a pair of steel rolls, revolving at a suitable pressure, his object being to devise some cheap and rapid process for the ornamentation of metals. A little specimen in one of the frames before you is an impression printed from one of the plates so engraved at this period. Mr. Sturges took out a patent for "ornamenting metallic surfaces," based upon the results he had arrived at. This patent is dated 24th January, 1852.* Specimens were shown about as curiosities, especially impressions printed from the plates. In assisting to bring this patent into operation, in the establishment of Messrs. R. W. Winfield and Son, Cambridge Street Works, Birmingham, Mr. W. C. Aitken made his first experiment on natural objects with a skeleton leaf, picked out of a roadside brook, early in the spring of 1852. An impression of this, together with one of the two plates, which Mr. Aitken presented to me, are now before you. This result was shown to me in a day or two after it was produced; therefore, I am speaking from experience, and not from hearsay, or upon any authority. Mr. Aitken subsequently brought the further results of his experiments before this Society, in a paper read in February, 1854, and printed in the *Society of Arts Journal*, vol. ii. p. 227.

In Mr. Henry Bradbury's paper, read at the Royal Institution, he says, "In the Imperial Printing Office at Vienna the first application of taking impressions of lace in plates of metal by means of metal rollers, took place in the month of May, 1852. It originated in the Minister of the Interior, Baumgartner, having received specimens from London, which so much attracted the attention of the Chief Director, that he determined to produce others like them." Now we all know what the Imperial Printing Office of Vienna showed in the Great Exhibition of 1851; and, beautiful, and even wonderful, as the specimens were, that there was nothing in any way approaching to nature printing. The Austrian commission, however, was busily employed in London until the end of 1851 or beginning of 1852. Its members visited Birmingham, as our foreign friends usually do on these occasions, as a relaxation from heavy duties, and from a laudable desire to obtain information.

Mr. R. F. Sturges was not a man to "hide his light under a bushel," and therefore I have little doubt that the specimens of impressions of lace from plates engraved by him were sent to the Austrian Minister of the Interior, being obtained, either directly or indirectly, from Mr. Sturges immediately after he had secured himself in England by patent. If not, where did they come from? No one else in this country had at this period done anything of the kind. Peter Kyhl had been dead and his experiments at Copenhagen forgotten, where alone they had been known eighteen years before.

If we compare the date of Mr. R. F. Sturges' patent, January 24, 1852, with the date given by Mr. H. Bradbury, May, in the same year, as the period of the first experiments at the Imperial Printing Office at Vienna, it will be seen at once that Mr. Sturges had no object in the concealment of his process or its results, for three months before anything was known or done at Vienna.

In making these remarks, I do so for the honour of Birmingham, and from a strong conviction, based on a personal knowledge of the facts, and not from hearsay, that the action of the Imperial Printing Office at Vienna was induced by the successful experiments made in Birmingham in 1851-2.

Having, thus, as an act of justice to an ingenious manufacturer, stated these facts as to the independent re-invention, at least, of this process, assuming Peter Kyhl's to have slept—as it really did—not only from 1833 to 1851, but, in fact, to 1855, when it was brought forward through the instrumentality of Professor Thiele, I may now briefly allude to the several processes employed for the reproduction of flat natural objects by means of metal plates and the printing press: the nature printing of Dr. Dresser by transfer from leaves of plants, &c., to paper direct, and his process of transfer to lithographic stones and printing therefrom, being outside the present question, although very interesting and useful in many points.

In 1847, Dr. Branson, of Sheffield, made a series of experiments, commencing with taking impressions of leaves in gutta-percha, from which he cast a brass mould to print from. An electrotype plate could also be obtained. In 1851, Dr. Branson brought this interesting subject and his processes before the Society of Arts.

* *Society of Arts Journal*, April 17, 1863.

* Patent No. 13,914.

After the Imperial Printing Office at Vienna had experimented upon lace, &c., in 1852, as already mentioned, we have Mr. Henry Bradbury's authority for stating that gutta-percha was tried by Andrew Worring, in whose name the patent was subsequently taken out. No doubt this plan was derived from Dr. Branson. This failing, he, says Mr. Bradbury, "employed," as Peter Kyhl had done before him, "soft lead plates." Yet, probably, Worring was as innocent of any knowledge of Kyhl's doings as Mr. Sturges was. This Mr. H. Bradbury acknowledges with regard to the former, and it is deeply to be regretted that he did not do so in regard to the latter, as I think that Worring, being connected with such an establishment as the Imperial Printing Office at Vienna, was much more likely to know of the existence of Peter Kyhl's manuscript in the Royal Library at Copenhagen, than a busy manufacturer at Birmingham. Mr. Henry Bradbury's process was taken from that practised at the Imperial Printing Office at Vienna, where he was engaged for a period, with such improvements as his great ingenuity and perseverance enabled him to introduce; and we see the result in the magnificent volumes published by Messrs. Bradbury and Evans.

In all these processes, however, the plate from which the impressions had to be printed was an electrotype copy of the soft lead plate in which the object was engraved, and a considerable amount of labour and skill in burnishing and touching up had to be expended before the plate was fit to yield a satisfactory impression.

This is not the case with the direct process, or with Mr. R. F. Sturges' method of copying lace, &c., and more particularly as carried out in reference to natural objects by Mr. W. C. Aitken. The impressions of the most delicate skeleton of a leaf, or a feather with its down, are impressed direct in all their delicacy and the plate is ready to print from at once.

It was this fact which led me to the experiments which have resulted in the process I am now to describe, for, on seeing the first specimen of a feather engraved by Mr. W. C. Aitken, early in 1852, I asked myself mentally, "If the down of a feather can be made to impress itself in a metal plate, and print, why not a drawing?" The next question was, "How to do it?" Urgent duties prevented any experiments until the winter of 1858. The result of these experiments I shall now give in detail.

No want has been more strongly felt in the arts than some easy rapid, and direct method by which the spirit and mental impress of the artist's own hand could be reproduced in a metal plate or type, either in intaglio or relieve. I remember reading, when a youth, in some old edition of the Life of Albert Durer, that he had solved this problem and had a secret method which died with him by which he could transfer a drawing to a metal type and print from it. Whether this was simply a mystical description, by some person ignorant of art-processes, of the ordinary method of etching, in which Durer was such an adept, I cannot say, but it made a deep impression on my mind, and the question how to bring about such a result was for years a subject of interest and speculation with myself, as it has no doubt been to hundreds of others. When, in 1842, Mr. Palmer commenced his experiments in glyptography, some friend, knowing my propensity to experiment in this direction, sent him to me, and I believe I executed for him the first drawing produced by his process, in which lines were drawn in imitation of etching, or the *fac-simile* style of wood engraving. After several experiments, however, not seeing my way to satisfactory artistic results, I declined to devote any more time to this process. I have ventured to name this as showing that my attention was by no means first drawn practically to this question, when the success of the direct nature engraving of my friend, Mr. W. C. Aitken, in 1852, directed it into a new channel. In fact every process of the kind had been practically examined and tested—etching on copper and steel, lithography, zincography, the anastatic process, the paneionography of Gillot, shown in the Exhibition of 1851, from which so much was expected in surface printing, had all had attention. The matter was, therefore, not taken up blindly, except in one point, and that a most important one, for every single step of the solution of the problem had to be taken practically in the dark, as there was no experience in the same direction to suggest, still less to guide, in a single experiment; and even now, after four or five years' experience, I rarely make an experiment without gaining some additional light, which either helps the certainty, or extends the operation of the process. I beg, therefore, most distinctly to state, that I do not bring this before you as a perfected process, but simply as a method which, so

far as, experience has gone, has produced certain undeniable artistic results, and as containing, as I believe it does, the elements of far higher, much wider, and more practical issues in the future. I trust no one will tell me that because the effects shown on this occasion are only produced in *intaglio*, that it would be much better for economical purposes to produce them in *relievo*, and thus suit them to the immense demand for surface printed illustrations. Of all this I am quite aware; but having so far accomplished one phase of the invention and undertaken to explain it, I shall confine myself to that. Should I, having already made a beginning, solve the other part of the problem, and produce a block where I now only produce a plate, I shall ask for another opportunity to bring that before you in due course. In the meantime our subject is the production of a metal plate engraved direct from a drawing and suitable to be printed from at an ordinary copperplate printing press, or for transfers in certain industrial arts.

(To be continued.)

Correspondence.

FOREIGN SCIENCE.

[FROM OUR SPECIAL CORRESPONDENT.]

Paris, April 22nd, 1863.

At the last meeting of our Photographic Society, Mr. Henner's communication on the modifications he has introduced into the treatment of photographic residues was read. His special aim has been to obviate the inconveniences, in a sanitary point of view, arising from the method hitherto employed for extracting the precious metals from the washing waters. One of the well-known methods adopted consists in immersing in the liquid, which is strongly acidulated, a bar of zinc or of iron. This method is excellent in practice, when adopted with certain liquids, but, if applied to photographic residues, it causes certain decompositions which we should endeavour to avoid.

Hyposulphite of soda and cyanide of potassium, for example, are often found in great quantity in the washing waters. By the action of the acid necessary to attack the zinc, *sulphurous acid* is formed, very irritating to the respiratory organs; and *hydrocyanic acid*, still more dangerous to inhale.

Another process consists in precipitating the gold and silver in the state of sulphides. If the waters are acidulated, which is almost always the case, there is a very intense disengagement of hydrosulphuric acid, when the alkaline sulphide is added. Now, we well know how disagreeable this gas is to respire.

To obviate these inconveniences, which often induce photographers to throw away the washings, or to sell them at a nominal price, Mr. Henner confines himself to *neutralizing the liquids*, and to keeping them in that state. It is easy to ascertain this condition by means of litmus paper. To effect this neutralization, we cannot employ the carbonates which cause a disengagement of carbonic acid, and, besides, are expensive. Caustic potassa and soda must, also, be avoided. Mr. Henner makes use of lime; or, rather, of *cream of lime*. It is thrown from time to time into the liquid residues, and left to settle. Thus, by this very simple method, the gold and silver are precipitated in the state of oxides, better adapted for melting than sulphides. In those cases where we suppose that traces of the precious metals still remain in the liquids after this treatment, it suffices to add a small quantity of alkaline sulphide, which, being employed after neutralization, has not the same inconveniences.

This method, successfully employed for several months by Mr. Henner, presents many advantages, of which photographers will, doubtless, gladly avail themselves.

Mr. Henner also announced that he has studied the method of manufacturing sulpho-cyanide of ammonium, and finds that it is possible to produce this useful product at a very low price. As to the properties, more or less injurious to health,

of this salt, Mr. Heppner has made comparative experiments, not yet completed, which, however, prove that the sulphocyanide of ammonium is far from possessing the poisonous properties of the cyanide of potassium.

M. Potteau exhibited some new proofs, which render his collection of the various types of the human race complete. He has also photographed certain anatomical specimens, which, from their flaccidity, could not be placed vertically: placed horizontally, and photographed from above, their forms are accurately depicted. M. Potteau also exhibited an interesting collection of costumes, views, and types, brought from Siam, by M. Beaufour.

M. Moisson sent some enamelled photographs. He first obtains a transparent positive in the usual way, covers it with yellow ochre, and allows it to dry. The plates are then placed in a muffle, and heated to a cherry red. The image is in this way vitrified, and incrusts in the substance of the glass.

M. Terrail has discovered a very ingenious process, by means of which he separates the coating of albumen containing the picture from the paper, without in any way damaging it. It can be rolled up or kept in a portfolio, and transferred to a glass plate or another piece of paper. This process will be found very useful for negatives and in travelling. M. Terrail obtains this result by parchmentizing the paper.

M. Roman, of Wesserling, sent some proofs executed by his dry process, and recommends the employment of a very minute quantity of pyrogallic acid after washing, as it is important for the preservation of the picture. M. Roman has ascertained that the sensibility of plates prepared by his method is nearly one-half less than that of plates prepared with wet collodion.

M. Meynier writes to the *Moniteur de la Photographie* in reference to the report presented by M. Teissère to the Photographic Society of Marseilles, upon the *sulpho-cyanide of ammonium*, which he (M. Meynier) was the first to propose for fixing photographic proofs without danger to the operator; he says:—"I regret that before publishing that report it was not communicated to me, as it involves the question of a process of manufacture supposed to emanate from myself, and the result of an experiment made in my presence.

"I have nothing to say concerning the essays attempted by the committee, which retains the responsibility of the results it has made known; but I wish to state a fact relative to the fixing experiment made in my presence upon the day, when, upon M. Teissère's invitation, I went to the laboratory of the Society. M. Teissère brought three stereoscopic pictures ready for fixing. Each was divided into two equal parts; the one was immersed in a solution of hyposulphite of soda, the other in a solution of sulpho-cyanide of ammonium. On being taken out of these solutions after fixing, all the halves fixed with the sulpho-cyanide appeared like, as to tint, those fixed in hyposulphite of soda. M. Teissère thought that those fixed in the hyposulphite were whiter than the others. A person present during the experiment, consulted on this point, declared, on the contrary, that those fixed in the sulpho-cyanide of ammonium were the whitest, from which it would appear to result that they did not differ sensibly one from another. This is all I wish to establish at the present time. However, I do not mean to say that the proofs upon albumenized paper may not subsequently acquire a bad tint, when fixed in sulpho cyanide. If it should prove so, we must search into the cause, and the explanation given by M. Teissère of the phenomenon of colouring he observed will still be premature, if not even in opposition to the properties of the salt with which he experimented.

"I have undertaken a series of experiments upon fixing positive proofs, the results of which I shall publish hereafter, if I am not anticipated by operators more skilful than myself, such as MM. Davanne and Girard, who are much occupied with the study of the new fixing salt, and who have already remarked the phenomenon of which M. Teissère

has spoken, but of which they have not yet discovered the real cause."

M. Belitsky gives an easy method of making a specific gravity bottle without its containing exactly 1,000 grains. Take a clean dry bottle of thin glass, with glass stopper, and ascertain its weight, then fill it completely with distilled water at 60° Fahrenheit, and wipe it clean. Then weigh the bottle, and the weight of the water may be easily found by deducting the weight of the bottle. To ascertain the weight of a liquid, fill the empty bottle with it, weigh it, and its specific weight is readily found. For example:—

The empty bottle weighs	...	349.34 grains.
Filled with distilled water at 60°		611.39 do.

Consequently the water weighs 262.05 do.

The bottle filled with alcohol weighs 568.66 do.

Consequently the alcohol = 219.32 do.

By the rule of proportion 262.05 : 219.32 :: 100 : x ;
 $x = 836.9$; which is the specific weight of the alcohol.

Proceedings of Societies.

MARSEILLES PHOTOGRAPHIC SOCIETY.

At the meeting of this Society, held on the 10th ulto., M. Rey gave an analysis of the publications received during the preceding month. He interested the members of the Society by the precise details he gave upon the various steps in progress recently accomplished. The facts upon which he particularly dwelt were:—M. Jeanrenaud's method of toning; M. Belitzki's researches upon the part water plays in collodion; M. Wharton Simpson's observations on the favourable effect of the fumes of ammonia in developing negatives obtained by the tannin process; M. Jeanrenaud's formula for collodion; M. Poitevin's account of his recent progress in carbon printing, &c.

The SECRETARY, in thanking M. Rey on behalf of the Society, called the attention of members to the importance of the facts noticed by the honourable member. He would, he said, sum up in a few minutes those works, the results of which promised to become the most favourable for the future of the new art. Photography, after having slumbered a few months, or rather, having taken that repose necessary for new researches, has awakened with a crowd of new ideas and discoveries, which are at once both conquests over the past and aids to future progress. M. Poitevin, who has so accustomed us to surprises, has startled us with the discovery of the curious reactions due to light. Doubtless, in consequence of other learned researches, we shall soon arrive at a truly practical application of carbon printing.

M. VIDAL insisted upon the practical value of the processes indicated by M. Jeanrenaud, a very skilful amateur, who has obtained very fine pictures by the dry process.

M. DE SIVRAY, director of the photographic operations of the Society, was invited to give an account of the experiments he had made with the water of Patako, sent to the Society by M. Clerville. His experiments show that this compound is very suitable for producing intense blacks in the negatives, where transitions from white to black are unnecessary; for instance, in reproducing plans or engravings. As to negatives with half tone they were less successful. It is true, however, that an intensified picture is never of equal value with a proof the effect of which is the result of a sufficient action of light.

Dr. MONCKHOVEN presented to the Society a copy of his new Treatise on Photography.

M. VIDAL, in the name of the Administrative Committee, proposed that letters of congratulation be addressed to MM. Poitevin, Bayard, and Duboscq, on the distinction they had obtained at the International Exhibition of 1862. This proposal was unanimously adopted.

M. GUIBAULT asked permission to read the draft of a letter addressed to the Minister of State, soliciting of His Excellency that works of art, the result of the application of photography, be admitted to the Fine Art Exhibition.

"MONSIEUR LE MINISTRE,—Among the works invited to be sent to the Art Exhibition of 1863 we do not see mentioned those executed by means of photography. We take the liberty

of addressing you a few remarks on the subject, on behalf of the Photographic Society of Marseilles.

"There is some confusion in the expression which has hitherto been adopted to designate everything proceeding from this admirable discovery, and we do not hesitate to attribute to this fact the omission which we take the liberty of pointing out to you. The term *photography* is employed indifferently both for the science and the art of photography. There is, however, a distinction to be made, and a word to be created. The term 'photographic science' appears to us a proper definition, but 'photographic art' is a term as little applicable to the thing as if we said the *art of perspective* for painting, or *grammatical art* for poetry.

"Photographic science proceeds from chemistry. It is one of its most interesting off-shoots. The chemist has placed in the hands of the artist and amateur an instrument which dispenses with the arduous studies of perspective and the mechanical labour of the crayon and the pencil. Reagents, processes for employing photographic substances, and instruments at the service of this employment form the body of this new and delicate science.

"As to photographic art, we are of opinion that it has not a name, and we wish it were possible to give it one, which should express in one word the idea of art by the heliographic process. Art, generally, has for its object the external manifestation, by various means, of the thoughts, feelings, and passions of the individual. Whether these means be writing and grammar, perspective and the pencil, or even photography, the aim is the same. Only, photography, which is unquestionably scientific, executing at the same stroke the work of the crayon and of the geometrician, permits of the art taking a more elevated range.

"It has been stated, Monsieur le Ministre, that photography materializes art. This could only proceed from persons ignorant both of art and of photography. The artist who employs these processes of expression has as much freedom to select from nature as the draughtsman who employs his crayon. Besides, in art, the process is a secondary matter. It is the idea, the choice of the mode employed to express it, that is essential. We think that it is by their manner of understanding this important point that artists are divided into painters of style, and realists. The one believe that they may represent the object of expression crudely, just as it is; the others think that they must represent this object only as it seems most apt to render the special idea they have in view. It has been said, that the design produced by the sun belongs to the realistic genus, as it brings out parts useless to the general effect. Moreover, as the photographic process is at the command of everybody who can master a few preliminary details, they add, that this method of expression belongs rather to the province of manufacture than to that of art.

"Happily, Monsieur le Ministre, among the numerous productions of photography may be found many admirable ones which show what the true artist can derive from this new source. Can we refuse to accord the title of "works of art" to the landscapes of M. Bisson, the portraits of M. Salomon, M. Nadar, or M. Carjat, or to the "studies" of M. Aguado?

"For the landscape artist, the choice of position, the hour of the day, the study of the various planes; for the *genre* painter, or the portrait painter, the attitude, costume, accessories, choice of light—are not all these the resources of the artist who employs the new process as well as of him who handles only the crayon and the pencil?

"If these considerations, Monsieur le Ministre, appear to you sufficient to cause an end to be put to the confusion which hitherto has mistaken the means for the cause, the instrument for the thought which directs it, we take the liberty of praying you to grant a place for original works produced by photographic processes in the approaching Fine Art Exhibition, upon the same conditions as those required for painting, sculpture, engraving or lithography.

We have the honour to be, Monsieur le Ministre,

Your Excellency's very humble and obedient servants,

MEMBERS OF THE MARSEILLES PHOTOGRAPHIC SOCIETY."

THE SECRETARY remarked that the Society did not intend to enter upon a discussion on a subject upon which there are so many different opinions: viz., whether photography is or is not an art. It is an undeniable fact that we can produce an artistic work by photography. This is what the Marseilles Photographic Society maintains, no one up to the present time has denied this fact; there is, therefore, good and sufficient reason to claim for these works of art the rank and place they merit.

THE SECRETARY announced that the Marseilles Photographic Exhibition is fully organised, and that it will be opened to the public after as short delay as possible. The Society has not aimed at making so considerable an exhibition as the first. The progress accomplished during the year will be best shown by the results. Inspired by this idea, the committee has limited the space and the number of exhibitors. To have organised a new great exhibition really susceptible of offering a new interest, it was necessary for time to permit the photographic art to produce, invent, and perfect, and, especially, practically apply.

Dry processes and the carbon process have made but little progress during the past year. But in another year, certainly, we shall see productions possessing very great interest.

The course of lectures on practical photography will coincide with the exhibition. M. Leon Vidal, entrusted with this difficult task, is quite ready to commence it.

THE PRESIDENT reminded amateurs that the laboratory of the *Union des Arts* is now organised, and that they will find all the facilities necessary for the material part of their labours.

PHOTOGRAPHIC SOCIETY OF PHILADELPHIA.

THE stated monthly meeting for March was held in the rooms of the Society, on the evening of Wednesday, March 4, 1863. Vice-President FREDERICK GRAEF in the chair.

After the usual preliminary business, the following gentlemen were elected members of the Society, Felix D. Crane, Richard D. Petit, and John H. Simmons. Dr. Van Monckhoven was elected a corresponding member.

COLEMAN SELLERS, corresponding secretary, reported having received a letter from a gentleman of Boston, who had taken a prominent part in the investigation of the spirit photographs, in which he says, "I agree with you perfectly in supposing that the plate in the bath is changed during the time that the dark room is entirely without light, as is the case when the plate is removed from the bath."

The secretary, Mr. BROWNE, read a letter from a Mr. Cox, giving a description, illustrated by photographs, of a wheelbarrow dark tent; the pictures of it were examined with interest.

Mr. TAYLOR read a communication from Mr. F. A. Wenderoth (who was prevented from being present by indisposition), on the subject of enlargements by artificial light. He had made an arrangement of lime light in combination with a quarter size portrait tube, but had not been very successful in printing by development direct on paper; he had, therefore, turned his attention to enlargement on collodion films. He had made two negatives enlarged from ordinary transparent glass stereographs; one of a view in the Alps, the other of the town of Altoona, Pa. The negatives were exhibited, also prints from them; they measured 20 x 16 inches, and were not remarkably sharp, as the position from which they had been amplified had not been made with a view to enlargement. Mr. Wenderoth gave an account of his experience with the solar camera, and seemed inclined to favour the idea of enlarging on glass and then printing by superposition, as better in a commercial point of view than the use of the solar camera. In the specimens exhibited the exposure had been forty-five and sixty seconds with lime light. There was also exhibited developed prints made by Mr. Wenderoth five years ago, which were considered by him more permanent than the ordinary prints.

Mr. J. W. HURNE exhibited two card pictures with spirit accompaniment, which he had made himself. He said that his acquaintance with the spirit world had been so recent that he had not been able to prepare as many of these specimens as he should have liked. The spirit pictures were exactly like the ones made by Mmmler, but the photographs, as a whole, were far better than his; he had gone ahead of Mr. Mmmler in one respect, inasmuch as one of his spirits was head downwards, showing conclusively that it must have been taken in the act of descending to the earth. After many amusing comments on them by himself and others, he said that the spirits were from positives, the impression being made by lamp light in one or two seconds, the portrait of the sitter being made afterwards with the usual exposure.

Mr. BROWNE passed around for inspection some copies of engravings made by himself, which were much admired; the tone was black, but clear. He stated that the toning solution made use of was prepared as follows:—Gold solution, one grain to the drachm. Toning solution, 4 ounces of warm water, 2 draehms

of gold solution; neutralize with bicarbonate of soda, and add 25 grains of salt, 20 grains of acetate of soda, and 20 grains of nitrate of uranium.

The Harrison and Schnitzer globe lens being alluded to, Mr. BROWNE said he would refer to the testimony which had been given regarding their quickness in landscape work, but was sure they were very slow indeed for copying purposes. He had exposed an engraving in bright sunshine for two minutes, and had got a poor negative. He would be glad to hear the opinion of gentlemen present on the subject.

Mr. SELLERS had had too little time to experiment, but could state that he had seen copies made with the 12-inch focus globe in much less time than Mr. Browne gave; and that he had always thought that the 6-inch globe used by Mr. Browne must be quicker than the 12-inch, inasmuch as the rule of "the shorter the focus the quicker the work," the areas of work being the same in both cameras, holds good with these new lenses.

Mr. HUGH DAVIDS showed a negative made from an oil painting of a landscape, green being the prominent colour. He had made this with an 8-inch focus in ten seconds; engravings he had copied in even less time.

Mr. MORAN had been working a pair of the 2½-inch focus globes, and said that they had far exceeded his most sanguine expectations. He displayed a number of views made on the Wissahickon creek; in these he had used all the various sized openings, the largest being used to take some cattle in the foreground. They were remarkably good pictures, and called forth many expressions of admiration. His exposure with the large opening had been not over two seconds, but he thought he had over-exposed all, at another time he would shorten his time of exposure, he was hesitating in expressing his opinion that they were far from being slow workers.

Mr. TAYLOR stated that he had tried various samples of blue glass with a view to making a new skylight, and that by placing various shades of blue glass over sensitive paper, and exposing to the light, the paper would print slower in proportion to the depth of blue under all the glasses; and that the blue light falling on red and yellow paper, making the one purple and the other green, and a negative made of the colour, the purple and the green were less sensitive than the red or yellow; showing that the only effect of the blue is to shut out some valuable light, just as a curtain would do.

Here the meeting assumed a conversational tone, and the various pictures exhibited were examined with care. Mr. Gray added to the collection on the walls of the society room, two fine photographs—one from Rome, the other from England—the latter by Mr. Fenton.—*American Journal of Photography.*

Photographic Notes and Queries.

TRANSMITTED POSITIVES, &c.

DEAR SIR,—Perhaps the following may interest your readers. I was copying a lithograph the other day and wanted to make it very clean. I tried Mr. Osborne's clearing up process, and on pouring on pyro and silver, I *always* got a transmitted positive where the solution was poured on first, and I could produce as many positive spots as I chose by changing the place of pouring on repeatedly.

The following plan produced a very beautiful positive by reflection. A tannin plate was flooded with 3 grains of pyro without acid. No result was produced. I accidentally poured silver without acid into the pyro, and flooded the plate, and a magnificent clean positive resulted. I then stopped the development.

I have a mode of toning which I think is economical. I use acetate of soda, as given at the end of your 5th vol. and never throw away my bath. About ten minutes before use I put in the estimated quantity of gold for my prints, at six drops of a No. 8 grain to an ounce solution per quarter sheet of Rive. I do not neutralize and never hardly have meanness now, but I always use a preliminary acetate bath as recommended, and wash for some minutes in distilled water; before that, each print is put separately in the toning bath, and kept in motion, turning it frequently till the colour begins to change, *then, and not till then*, is it safe to leave it till toned. I fix in strong hypos. A bottle is filled one-third with the salt, and filled up with water, add a lump or two of chalk and use till the silver begins to be thrown down by light on the side of the bottle. When

this happens, I add a few drops of sulphuric acid to the hypos. Sun for two or three hours (of course the chalk must be out), and filter, neutralize with chalk, and filter again, and add more hypos to restore its strength. I send a specimen print.—Yours faithfully,
AN AMATEUR.

SIMPLE PLATE HOLDER.

SIR,—Having frequently noticed in the NEWS various suggestions for plate-holders, I trust you will allow me as an amateur to describe for the benefit of others a holder which I have contrived for my own use, for quarter and stereo plates, and which for portability, cleanliness, cheapness, and efficiency, I have found superior to anything I have been able to purchase.

It consists mainly of a small pair of ordinary pliers; round the nipping ends of these I tightly wind a few turns of string in order to prevent breakage or contact of metal with the plate as well as to give a better bite. Next I twist *tightly* round the handles an ordinary india-rubber ring, such as is used for binding papers, &c. This keeps the nippers firmly closed.

By inserting the two first fingers of the left hand between the handles a very slight effort is sufficient to open the blades widely enough to insert the plate.

Stereo plates are best held by the centre, as the leverage is otherwise too great to allow a firm hold. This plan too sacrifices less of the picture.

The whole costs me sixpence!—Yours obediently,

ARTHUR DALTON.

WEAK PRINTING BATHS.

SIR,—Should you deem the following communication worth notice, you are at liberty. I have been trying several experiments, lately, with different strengths of silver for floating paper. I find that with a weak solution I can produce a more brilliant print than with a strong one, providing a quantity of nitrate of soda be added. I operate as follows: Float five minutes on a solution, nitrate silver 20 grains, nitrate soda 60 grains, aqua 1 ounce; print rather deep and tone as usual. It will be noticed that they print rather redder and tone much quicker.

I enclose you three prints of one negative from one sheet of paper; No. 1 was done in the usual way, with a 70-grain solution of silver; No. 2 with a 20-grain solution of silver and 20-grains nitrate of soda; No. 3, silver solution 20 grains, nitrate soda 60 grains. You will see that a large proportion of nitrate of soda is necessary. I have not yet determined what proportion gives the best results; I will leave it to some experimenter who may have more time than I have.—I remain, Sir, yours, respectfully,
PUBBICOLO.

P.S.—I will send, in a few days, a recipe for a toning bath which I believe superior to any in use.

[The experiments of our correspondent seem to run parallel with those of Mr. Anthony recently recorded. Of the prints enclosed, No. 3 is about equal to No. 1, and both are superior to No. 2. Another print enclosed is marked as floated on a 5-grain silver bath, with 60 grains of nitrate of soda. It is somewhat mealy, which is ascribed to the over rapid toning induced, the effect having been produced by a 30 seconds immersion in the gold bath. We shall be glad to receive the toning recipe.—Ed.]

Talk in the Studio.

CONCERT IN AID OF A PHOTOGRAPHER.—Mr. John Watson, a photographer of old standing in the metropolis, well known to old photographers, has recently had the misfortune to become totally blind. A concert will be given on Monday evening next, at the Hanover Square Rooms, with a view to raising funds on his behalf. Those of our readers who would enjoy good music,—for a fine programme is provided,—and at the same time enjoy the "luxury of doing good," will do well to attend. The tickets are from half-a-crown to seven and sixpence each, to be had at the rooms and of various agents.

To Correspondents.

CONSTANT READER writes as follows:—"I am an artist at a photographic establishment (that is to say, I paint in oil and water colours in all its branches). I have a son, whom I have apprenticed to my employer at the same establishment. The indentures run that by the consent of his father, artist, he doth put himself apprentice to W. R. of C—, photo-

grapher, to learn his art, and with him after the manner of an apprentice to serve, &c. It then goes on in the usual printed form, that he shall serve his master faithfully, keep his secrets, and obey his lawful commands, &c., &c. At the close it states that the master shall teach, or cause to be instructed as a PHOTOGRAPHER the said apprentice. There is nothing about painting named in the indentures. When these indentures were signed I painted six days in the week, now I print three days only. My employer orders my boy, as his apprentice, to paint his photographs, and tells me and him that he can make him do so, and that he has a right to enforce it. Having laid the case before you, I beg to ask if you consider it as part of the duty of a photographer's apprentice to paint photographs. You will kindly be particular in this matter, as I have no doubt there are many similar cases." The question involved is a legal one, and will be decided by the construction of the phrasing in the indenture. Our opinion of the matter is, that painting portraits is no part whatever of a photographer's duty, or of his apprentice; and it is probable that the law will give the same decision.

W.—The brown colour of your prints appears to be the result of imperfect fixation. The hypo bath is either old or weak, or the prints have been stuck together whilst in the hypo bath. Probably in this case the latter, as the shape of one print is distinctly marked upon another, causing a stain and showing the contact. We suspect, moreover, that the toning, or fixing, or both, was conducted in the presence of some white light. We regret our inability to answer letters on difficulties of this kind by post, as such an undertaking would fully occupy our time. Such letters are not even read through when they arrive, but placed aside to receive attention on a day set apart for that duty in each week.

A.—The fact of the minute holes occurring always in one place, and near the end of the plate resting at the bottom of the silver bath, would suggest some turbidity in the bath, which rises for an inch or two upon the immersion of each plate. There are many causes of such pin-holes, but none that we know of by which the defects would be confined to one part of the plate always.

LUCIFER.—There are several good tents manufactured. We may especially mention Edward's Model Tent, by Rouch; and Smart's Tent, by Murray and Heath. How far they will be suitable for a tropical climate we cannot state. *A priori*, we should think a developing box, which does not envelope the head, would be most suitable.

X. Y. Z.—The best material for the window of a dark room is a suitable yellow glass. Where that is inconvenient, and a yellow blind only is required, Mr. Smart's silk is best; but if that be too expensive, two or three thicknesses of deep yellow calico, renewed whenever it fades, is the next best thing. It is a good plan to have one or two thicknesses of the yellow calico, and a thickness of yellow tannin. This does not fade, and it protects the calico.

W. W. H. WARNER, of Ross, requests us to explain that some delay in executing orders in hand for the profession may arise from some alterations, and the construction of a hot-water apparatus in his printing-house.

TYRO.—We do not know the gentleman you name. We do not consider £2 weekly too high a salary for a competent photographic printer in the country. We shall be glad to receive the communication referred to.

CHARLES CONNOR.—We do not clearly understand the nature of the deposit to which you refer as forming on some portions of your negatives; nor does the print enlighten us. Is the deposit fog?

H. M. R.—We have never used iodoform for the purpose of rendering a horny collodion porous. 2. We have no data upon which to form an opinion as to the quantity to be used. 3. Agitating the collodion with bicarbonate of soda will produce the result, and has, in our hands, been successful. After agitation let it stand for a day or two, and then decant from the sediment.

SUBSCRIBER D's note is written so illegibly that we are by no means certain that we read it correctly. 1. Grape sugar may be obtained in various ways, and from various sources, from grapes dried and fresh, from honey, from starch, &c. Neutralise the expressed juice of the grape with chalk, strain, add a little white of egg, boil, and evaporate until the sp. gr. is 1.32. Then allow to cool, the result is grape sugar or glucose in a solid mass. For details of other methods of preparing it, see any work on organic chemistry. 2. We have in use a gold toning bath which has been made for weeks, which shows no signs of the precipitation you deem inevitable. When the solution of chloride of gold is neutral, it is, however, very easily decomposed. We have repeatedly given formulae for gold solutions which will keep without decomposition. The gold precipitated from such solutions, by means of sulphate of iron, is in the form of a dark powder. It may be converted into chloride of gold by nitro-hydrochloric acid in the usual way. It is scarcely fair to bring papers before societies for the purpose of advertising secret preparations. It is also against rule, although such things sometimes creep in before those concerned to repress them are aware. We never publish such papers. All photographers should be familiar with the decimal system of weights and measures, which is likely eventually to come into general use. As a rule, however, we translate them; when they appear without translation into familiar terms it is from oversight. A table giving the equivalent terms used in this country is given in our ALMANAC.

J. D. Z.—The suitability of a quarter-plate lens for enlarging, and the extent of its powers, depends much upon its construction; quarter-plate lenses by different makers vary, so you can only learn by experiment the capabilities of your own. Mr. McNab, in referring to reversing the lens, simply means that the end usually towards the sitter should, in enlarging, be towards the sensitive plate. A Dallmeyer's No. 1 triple is peculiarly well suited for enlarging. We cannot say exactly the extent of amplification which may be secured without loss of definition; much will depend on the original to be enlarged, and much on the manipulation; but we have seen a card picture enlarged to a whole sheet of paper with excellent results. In copying an albumenized print you must be careful that no light is reflected from its glazed surface, or a deposit will be the result. You can only ascertain by experiment in your own studio the best mode of placing it to avoid such reflections. The defect in the paper is from bubbles in albumenizing.

PHILIP CRELIN, JUN.—Your pictures in the room are a little under-exposed. The definition is more or less faulty in all, apparently from the imperfection of the lens, but, possibly, from want of careful manipulation.

W. S.—We like the pictures received much. We will examine them more in

detail in our next. We will forward the card, asked for some time ago shortly.

M. P. R.—When a correspondent tells us he has carefully followed instructions and failed, with a process with which we and thousands of others have always succeeded, it is very difficult to give him a reason for his failure. We can only give the advice to try again more carefully, or change the materials. The print enclosed is certainly not toned at all, and, apparently, imperfectly fixed. The negative appears to be tolerably good. Such a stain might arise from various causes. Read the article on "Imperfect Fixation," in our last ALMANAC.

J. C. V.—Many authorities have condemned the use of methylated spirit for collodion. We think, without sufficient trial or good reason. We have used it for many years, without ever perceiving any bad result, either to the collodion or silver bath. The chief danger from its use is the possible presence of impurities in it. You must not use the "methylated finish," containing a certain amount of some resin that will, probably, make the collodion unstable, and, possibly, foggy. We see no reason why the presence of wood spirit, if pure, should be injurious.

N. 290.—It is quite possible to obtain good negatives with a bromo-iodized collodion and neutral bath. We frequently use both. 2. Of the three lenses by Dallmeyer, regarding which you inquire, each has its special use and value. For card portraits No. 2 B is best, if you have length of room. No. 1 gives very good pictures, but requires a smaller aperture to give the same definition, and is, consequently, not quite so rapid. The stereoscopic lens is of shorter focus still, and, of course, gives a smaller picture; but is excellent for stereoscopic purposes. No. 1 B will cover a larger extent with a larger aperture than the stereoscopic, and is, therefore, practically more rapid. The No. 2 B will, of course, cover a larger plate still. How large we cannot certainly say; probably about 6x5.

A. C. P.—In our own experience, that which you mention as being "very highly spoken of," you are somewhat in error as to the standing of the respective persons; but we cannot discuss the matter here. We can explain more when we see you.

A.—We have no faith whatever in the statement made. We have recently had a report from a very able photographer, giving a totally different account. The results were said to be very unsatisfactory. A report on such a subject will always, of course, be influenced by the taste or appreciative powers of the reporter. Some people are satisfied with very little, and quite charmed with mediocrity.

W. H. SIMONS.—We cannot tell you certainly whether the engravings in the illustrated journal in question are copyright or not. We should presume they are. And, what is still more probable, they may be copies of copyright photographs which are engraved by permission; in which case you would be infringing the law by copying them. You will run great risk of breaking the law of the land, and will certainly infringe the moral law if you make copies without ascertaining absolutely that no personal property exists in the pictures.

A. R. P.—The best remedy for loosening of the film consists in using perfectly clean plates, an adherent collodion, a nitrate bath not too acid, and in careful manipulation. In asking the number of prints a given quantity of hyposulphite will fix, you omit the most important element in the calculation, namely, the size of the prints. Read the article on "Fixing" in our last ALMANAC. A toning bath made with acetate of soda may be used over and over until it is exhausted. There is no difficulty in obtaining grey tones with it. If there be the slightest acid reaction neutralize with carbonate of lime.

YELLOW GLASS.—Two samples of glass have been sent by A. L. for examination in the spectroscopie. They are prepared with gelatine and nitrate of silver, and when viewed by transmitted light, have a dark reddish brown, translucent appearance. In the spectroscopie, however, they are seen to transmit red, yellow, and green rays up to the blue, and arc, therefore, unfit for employment in the windows of the dark-room. A piece of orange oiled-silk sent has the same faults as the above, but in a less degree.

G. C. C.—The dissolving, partial or entire, of the image in varnishing may proceed from two or three causes, some of which were discussed at the last meeting of the London Photographic Society, reported in our pages for April 10th. In your case it appears to have arisen from a certain condition of the collodion and the highly rectified spirit of which the varnish is made. Old collodion, or collodion made from gum-cotton produced at a high temperature, is most liable to this accident, being, to some extent, soluble in strong alcohol. The remedy consists in firstly allowing the varnish to stand for a few days without cork or stopper in a moist atmosphere, so that it may imbibe a little water. Adding a weaker spirit, or a drop or two of water, might answer, but would leave the varnish turbid for a time. Also taking care to use the least possible heat in varnishing, as heat aids the solution. Finally avoiding the use of the same varnish with the same collodion. Negatives suspected of the tendency may be safely varnished with a benzole varnish or a chloroform varnish, but not with a spirit varnish. The benzoin or amber varnishes may be used.

J. INSKIP.—We are obliged by your communication, and will make use of it in our next.

Several correspondents in our next.

Photographs Registered during the Past Week.

- MR. JOHN JAMES WILSON, Eton, Bucks.
Photograph of Mr. William Leggatt.
- MR. A. S. WATSON, 2, Regent Road, Great Yarmouth.
Photograph of Miss North.
- MESSRS. MINSHULL AND HUGHES, Eastgate Row, Chester.
Photograph of the Hon. Robert Bourke.
- MR. THEOPHILUS SMITH, 16, Cemetery Road, Sheffield.
Three Photographs of the Rt. Hon. Lord Wharfedale.
Two Photographs of His Grace the Duke of Newcastle.
- MR. THOMAS HEAGREN REID, English Street, Carlisle.
Photograph of Napoleon I., as exhumed at St. Helena.
- MR. THOMAS MILLARD, 39, Lower Sackville Street, Dublin.
Five Photographs of Rev. John Nash Griffin.
- MR. JOHN GREENLAND, 1, Orchard Street, Portman Square.
Photograph of scene of the "Lime-tree Walk" in *Judy Auld's Secret*, as performed at St. James's Theatre, with full length portraits of Miss Herbert and Mr. Stirling.

THE PHOTOGRAPHIC NEWS.

Vol. VII. No. 243. — May 1, 1863.

CONTENTS.

	PAGE		PAGE
Iron Intensifiers	205	General Study of Photographic Positives. By MM. Davanne and Girard	210
Improved Solar Camera	205	The New Art of Auto-Typography. By George Wallis	212
Neutralizing the Toning Bath	205	Photographic Piracy of Engravings	214
Practical Notes on the New Fixing Agents. By G. Wharton Simpson	206	Proceedings of Societies	215
On the Development and Intensifying of the Negative Image. By Valentine Blanchard	208	Miscellaneous	215
Photographic Chemicals	209	Talk in the Studio	216
On the Influence of Sulphate of Silver in the Sensitizing Negative Bath	210	To Correspondents	216
		Photographs Registered during the past Week	216

IRON INTENSIFIERS.

ONE of the few disadvantages attending iron development is the frequent necessity for after intensifying with pyrogallic acid and silver, or some other preparation. Thus, not only two operations have to be gone through with careful washing between, but two solutions have to be kept prepared. Where rapidity of operations is of importance, as in large portrait establishments, or where rapidly changing aspects of nature are to be secured by instantaneous photography, the delay involved is a serious inconvenience.

Pending the success of the various experiments for securing sufficient intensity with an iron salt by the single operation of development, a method of intensifying with iron instead of pyrogallic acid will often be found of the greatest value. On another page we publish a communication from Mr. V. Blanchard to the final suggestion of which we call especial attention. It refers to the use of a weak iron solution with excess of citric acid in place of the usual pyrogallic solution for intensifying.

We have, during the last few months, been trying this preparation, and with unvarying success. Made in the proportion mentioned by Mr. Blanchard—five grains of iron, with ten grains of citric acid, in one ounce of water—it permits the addition of silver freely, and even when placed in the sunlight does not decompose. It intensifies the image readily, either before or after fixing, without the slightest tendency to fog the shadows. If used before fixing, it may be applied to the plate after the ordinary iron developer, without washing, which is so imperatively necessary with pyrogallic acid, and in such case it develops us well as intensifies, really bringing up detail not before apparent. In field operations, thus dispensing with present washing or future intensifying is of great advantage, and Mr. Blanchard has thoroughly tested its value in all his instantaneous work, during the last summer. The solution may be kept prepared for an indefinite time, and appears to improve with age. The proportions stated are not arbitrary, but have been found most generally useful as stated. The citric acid may, in cold weather, be reduced to the same quantity as the iron, or even less. Mr. Mainwaring, at the last meeting of the North London Society, showed a print from a rapid plate, which had been intensified with five grains of iron and five of citric acid. Tartaric acid may be substituted for citric acid, and we have recently found it quite possible, where rapid and vigorous intensifying was necessary, on a phantom image, to use a fifteen-grain iron solution, with three grains of tartaric acid, and to add silver freely, without any sign of decomposition, until after sufficient intensity was obtained.

We have recently been making experiments with other iron developers, for obtaining sufficient intensity at one operation. We do not like to speak with certainty upon the results of a few experiments; but hitherto we have obtained the best results with the saccharo-sulphate, great intensity,

with clean shadows and delicate gradation, being obtained by the simple process of development.

We have tried the formulæ of M. Renet with tartaric acid recently given in the letter of our Paris correspondent. Used as there stated, we find that a considerably increased exposure is necessary, the amount of citric acid being considerably in excess of what is necessary. The negatives develop very slowly, but are exceedingly delicate and clean. Probably one-third of the amount of acid would yield more satisfactory results.

IMPROVED SOLAR CAMERA.

WE have received from Mr. Stuart, of Glasgow, a couple of enlarged prints, in illustration of the powers of his improved solar camera. In order to enable us to judge more correctly of the results, they are from the same negative from which one of the prints we noticed some months ago was produced. With the solar camera in its old form, an exposure of two hours in continuous sunlight was necessary to complete the printing. The print before us was completed in one hour of sunlight, during which, however, there were three or four interruptions from the withdrawal of the sun. The negative had, moreover, from standing all this winter unvarnished, become brown and tarnished, and thus less rapid in printing. The prints are as sharp as we could desire, and beautifully modelled. The greatly increased rapidity of printing being obtained without any sacrifice of results.

We hope shortly to publish a detailed account of the improved apparatus; but we may remark in the mean time, that the accession of rapidity is largely due to the entire discarding of the mirror, and securing the necessary movements for obtaining the direct and continuous action of the sun through the condenser without displacement or interruption.

NEUTRALIZING THE TONING BATH.

ONE of the difficulties in preparing the alkaline gold toning bath arises out of the varying amount of acidity in different samples of chloride of gold. This renders it impossible to prescribe a definite proportion of carbonate of soda as the right amount to neutralize the acid present. And as excess of acid produces mealiness in toning, and excess of alkali frequently prevents toning altogether, it happens that where carbonate of soda is used, the most variable and unsatisfactory results are produced. Where the neutral salts of soda are added, more complex reactions follow, the hydrochloric acid is neutralized, but the weaker acid, in combination with the soda, is set free and remains in the solution. The toning is more regular and satisfactory, but unless the print be well washed before fixing, there is some danger that the traces of acid in the print may decompose the hyposulphite solution and thus, by liberating sulphur, peril the permanency of the print.

We have frequently felt it desirable to immerse the prints in a dilute solution of carbonate of soda between the operations of toning and fixing. This method, although effectual, is somewhat troublesome as involving one extra operation.

A better plan consists in neutralizing the free acid in the gold bath by means of carbonate of lime or common chalk in powder. Where a soluble alkali is used, it is of course easy to get an excess in solution; the carbonate of lime being insoluble, or nearly so, in water, neutralizes any free acid by its presence, whilst merely in a fine state of subdivision suspended in the solution, the precipitate being easily removed by subsidence or filtration, whilst excess in solution is impossible. This has before been generally recommended, in formulae in connection with chloride of lime; but there is no reason why it should not be used together with acetate of soda and similar salts. Mr. Frank Eliot, well known to many photographers as a skilful and intelligent printer, informs us that he uses in this way with the most complete success.

PRACTICAL NOTES ON THE NEW FIXING AGENTS.

BY G. WILKINSON SIMPSON.*

The practical results of the new fixing agents have been, in my hands, decidedly satisfactory. It is scarcely necessary to say more than this to obtain for the subject some interest and attention. It is unnecessary to dwell upon the importance of the questions involved: perhaps at no previous time were photographers so thoroughly alive to the subject. Much has been eloquently spoken and written of late years on the primary importance of good printing, and still more has been written and said, despondingly, of the imperfection of a process which depended upon hyposulphite of soda as a fixing agent. Not that good and permanent prints were not frequently produced by its aid; but that it was uncertain, was the complaint. It often "paltered with us in a double sense," and destroyed our reliance upon it. Its instability and treachery were its faults.

When a substitute for hyposulphite of soda for fixing prints, and for cyanide of potassium for fixing negatives, possessing many of the good qualities of both, and free from many of the faults of either, was suggested by M. Meynier, I, in common with many others looked for further information on the subject with considerable interest. And when the Committee appointed by the Photographic Society of Marseilles, to examine and report upon the subject, rendered an unfavourable account of the matter, stating, that the whites of albumenized prints became somewhat yellow under the action of the sulpho-cyanide of ammonium, I felt a good deal of disappointment. The committee appointed by the Photographic Society of Paris reported more favourably, but from their report there appeared to be some drawbacks to its use, such as the necessity of using a second bath of the salt to remove all traces of the compound formed by the action of the first.

In my hands the results seem to have been more satisfactory than those recorded in the reports referred to. Whether from some difference in the sample of the salt used, or from some other unnoted conditions, I do not undertake to determine; but the fact is so, that in my experiments, I have not met with some of the difficulties before recorded, as the results I will show you and the details I shall state will illustrate.

My only purpose in these brief notes is to refer to the practical results of a few experiments I have tried, recording my experience, where it differs from that of some eminent authorities who have written on the subject, with some hesitation and diffidence. The subject is, however, a new one; recognized authorities differ in the properties they ascribe to the sulpho-cyanides. The question for photographers must

be settled practically, and for this reason I record the facts I have observed. The theory of the subject I do not enter into at all. On that, something is probably still to be learned; in the meantime I commend attention to the interesting article on the subject by MM. Davanne and Girard, which will doubtless be published in all the journals.

I may premise the account of my results by referring to the advantages claimed for the sulpho-cyanides over the hyposulphites as fixing agents for positive prints. The sulpho-cyanides are more stable, not being easily decomposed so as to yield free sulphur or sulphuretted compounds, no part of the manipulation or materials used in positive printing having any tendency to liberate sulphur. Exactly the opposite facts to these are, as we know, true of the hyposulphites used. The salt formed by the reaction with silver salts and the sulpho-cyanides is readily soluble in excess of the latter, not forming at any stage a salt insoluble in the sulpho-cyanide solution. With hyposulphite, as we know, the opposite fact is true, as the perpetual stains from touching the unfixed print with fingers which have been in contact with hyposulphite, and from imperfect fixation, too abundantly prove. With the sulpho-cyanides the photographer is freed from this trouble, the sulpho-cyanide of silver formed by the reaction between nitrate of silver or chloride of silver and an alkaline sulpho-cyanide being readily soluble, even after exposure to light, in the latter. The sulpho-cyanide of ammonium is said to be a more perfect solvent for what is termed the albuminate of silver than hyposulphite of soda. The sulpho-cyanide is much more readily removed by washing from the print than the hyposulphite. There are some other advantages, but these are of the chief importance to the photographer.

I have used the term sulpho-cyanides in the plural because I have tried two: the sulpho-cyanide of ammonium and the sulpho-cyanide of potassium. The other sulpho-cyanides have not, I believe, been tried for photographic purposes.

The sulpho-cyanide of ammonium I have used, is, I believe, a very pure sample, prepared by Messrs. Hopkins and Williamus. I used a solution containing one part of the salt in three of water. An albumenized print a little more over-exposed and over-toned than for hyposulphite fixing, as I had been led, from the record of other experiments, to believe would be necessary, was immersed in the sulpho-cyanide solution. The results which followed were in all respects, so far as the eye could perceive, similar to those with a strong solution of fresh hyposulphite of soda, but the changes were a little more rapid. The print first turned very red and gradually resumed, in the course of a few minutes, its original purple tone. I left it for a quarter of an hour, or thereabouts, and then washed carefully. The resulting print was too dark and too black. The action of the sulpho-cyanide had not been to reduce the depth or the colour as I had anticipated.

I then printed some others just the depth, and toned to just the colour, I should have done for hypo fixing, and treated them with the sulpho-cyanide in the mode just described, and with some variations to be referred to. Some of the prints I now produce, and I think you will agree with me that they are as good in tone, as pure in the whites, and as brilliant generally, if not better, than the hypo-fixed print produced at the same time, from the same negative, and with similar conditions in all respects, except in the fixing. I found no trace whatever of the yellowness of the whites described by the Marseilles Committee, until I introduced other conditions which I shall describe presently. Some of the prints are, as you will perceive, on ordinary albumenized paper, and some on the albumenized enamelled paper recently introduced. I did not find in any case the slightest loss of tone produced by fixing.

I next tried the sulpho-cyanide of potassium, a sample forwarded to me for trial by Messrs. Bailey and Son, of Wolverhampton. After one or two tentative experiments, I made a solution containing one part of the sulpho-cyanide of potassium in two parts of water, and proceeded as described

* Read at a Meeting of the North London Photographic Association, April 22.

with the sulpho-cyanide of ammonium. The result was in many respects similar, with these differences: that the depth appeared a little less reduced and the colour a little more. The depth appeared to be less reduced than with new hyposulphite; the colour was a little more reddened than with the sulpho-cyanide of ammonium, but the loss of colour was not greater than often occurs with new hypo. In some of the prints I fancied there was greater brilliancy when the sulpho-cyanide of ammonium was used than when the potassium base was present; but in others I felt doubtful. Whether the difference in the results was actually due to the different bases present, or was due to the especial samples used, I cannot say. The sulpho-cyanide of potassium, it is perhaps necessary to say, appears to possess little more than half the energy of sulpho-cyanide of ammonium as a solvent of salts of silver.

In none of the cases where the solutions used were of the strength indicated was the slightest yellowness in the whites apparent. I did, however, contrive to get it. After fixing several prints in a small quantity of sulpho-cyanide of ammonium, and allowing the solution to stand for a day or two in an open vessel, a toned print was immersed in it, which immediately assumed a bright yellow tint, approaching orange. The print, when submitted, however, to a fresh solution, one part in three gradually resumed its proper tint, the lights becoming perfectly white and pure. On another occasion I essayed to fix a print in a solution of sulpho-cyanide of potassium, one part of the salt in five of water. The result was that the print assumed a deep orange tint at once. It did not occur to me then to try a stronger solution, and the print was thrown away as a failure. Whether this result will occur on all occasions where weak or exhausted solutions are used, I am uncertain. I have only tried it twice, and with those results. What is the exact nature of the decomposition I am uncertain, but it is probable that the yellow colour is due to sulpho-cyanogen.

There is another point on which I found my experience with that of some of the French authorities. We are told that on immersing the print in the fixing bath it becomes covered with a white veil of sulpho-cyanide of silver, and also that on first immersing the print in the washing water the latter becomes turbid, the result of a decomposition of the double sulpho-cyanide of ammonium and silver, effected by the water; and that for these causes the print requires removing to a second fresh bath of the fixing agent, of the same strength as the first, in order to remove the traces of sulpho-cyanide of silver left in the print. So far as I have been able by careful observation to perceive, I have not met with those results, although there appears every theoretical reason that they should take place*. The only changes I have seen in the print whilst in the fixing solution are those I have described as resembling the changes produced by hypo. The print first reddens and then resumes the tone it acquired in the gold bath, without any appearance of a veil. On immersing the prints fresh from the sulpho-cyanide solution in a limited quantity of washing water I could perceive no turbidity except in the cases where a weak or exhausted solution was used for fixing. Some of the prints, however, I immersed, as directed, in a second fresh fixing bath. I have not, as yet, been able to detect any difference in the results where this precaution is taken.

* The reactions which take place are thus stated: On immersing the print in a sulpho-cyanide solution, the sulpho-cyanide of silver is formed, which is dissolved again by the excess of sulpho-cyanide of ammonium, and a double sulpho-cyanide of ammonium and silver is the result. This double salt is not soluble in water, but is decomposed by it into sulpho-cyanide of ammonium, and sulpho-cyanide of silver; the former being dissolved in the water. The latter, being insoluble in water, is left, to some extent, in the print. Hence the apparent necessity for successive baths of sulpho-cyanide of ammonium to remove, as far as possible, all traces of sulpho-cyanide of silver from the print. Experience alone will determine the extent to which these successive baths are necessary. We have now some prints fixed as described, and, probably, containing some traces of sulpho-cyanide of silver, placed in strong sunlight to see if any darkening is the result. One print was merely rinsed in one or two changes of water, after leaving the sulpho-cyanide of ammonium; neither this nor the others have as yet, after several days' exposure, shown any change.

The salts are extremely soluble, and the washing appears to be very easily effected. As the per-salts of iron are a most perfect and delicate test for the presence of a sulpho-cyanide, by striking a blood-red colour, it will be easy to ascertain when they are effectually removed from the print by washing.

I may state that all the comparative experiments were conducted under, as nearly as possible, the same conditions. The paper was excited on a neutral, and somewhat weak, silver bath, containing about fifty grains to the ounce of water; the toning by an acetate of soda and chloride of gold bath made some weeks ago.

Regarding the permanency of the prints, we cannot, of course, as yet speak with certainty; we can only rest satisfied that we have secured some better conditions of permanency. On one point, I must confess that I feel considerable disappointment. I refer to the presence, in the fixed prints, of traces of silver in the whites, just in the same degree as in hypo-fixed prints. From the experiments of my friend, Mr. Spiller, and the opinion of some of the French authorities, I had been led to hope that the sulpho-cyanide of ammonium was a perfect solvent for the compound formed between nitrate of silver and albumen. Mr. Spiller's experiments consisted, however, in submitting the hypo-fixed prints, after perfect washing, to a concentrated bath of sulpho-cyanide of ammonium. This, he found, removed the traces of silver remaining, in combination with the albumen, in the whites. In my own hands, the prints fixed as described, washed, and dried, exhibit the characteristic brown stain, indicating the presence of silver, when sulphide of ammonium is applied to the whites, and in just about the same degree as hypo-fixed prints. All the prints I have tried give this result; whether treated with the ammonium or potassium salt; whether submitted to the action of a second fixing solution or not; and whether immersed a few minutes or a few hours.

As a fixing agent for negatives I have not tried these salts to any great extent. In the degree of concentration I have mentioned, namely, one part of the salt in three of water, they dissolve the iodide of silver very slowly; too slowly for use by pouring on to the plate, as the process would be most tedious. If used as a bath for immersing the plate, I have reason to believe that the solution will lose much of its energy by standing in an open vessel. The only mode of using it for negatives with advantage appears to consist in the employment of a very concentrated solution.

In regard to the poisonous character of this salt some doubt seems to exist. Various authorities state that hydro-sulphocyanic acid has a similar poisonous action to hydro-cyanic acid, and we would naturally infer that the sulpho-cyanides possess a poisonous action similar to the cyanides. M. Meynier says they do not, and Fownes, regarded as a careful writer in this country, makes a similar remark. The only evidence I have on the subject was a painful irritation set up by the action of the solution on a scratched finger.

In the course of various experiments not necessary to detail here, I met with one result which appears to contradict very distinctly the opinion of various authorities. Grotthuss, for instance, a German chemist, says that "sulpho-cyanide of silver blackens by exposure to light even more quickly than the chloride," a fact which, if true, would be of considerable interest to photographers. Other authorities make similar statements. I precipitated a quantity of sulpho-cyanide of silver by the decomposition of sulpho-cyanide of ammonium and nitrate of silver, and exposed it to diffused light for a day without any change or blackening taking place. Thinking that it was possible that the presence of free nitrate of silver might assist blackening I added some nitrate solution to the sulpho-cyanide. It has now stood for two days more in diffused light without any change, as you may perceive from the sample I now pro-

duce.* This is very readily soluble in excess of sulphocyanide of ammonium.

The question of price becomes finally an important consideration. On that subject I am afraid that I cannot at present give any very satisfactory information. As at present manufactured there does not appear any chance of the sulpho-cyanide of ammonium becoming a cheap salt. The price of that I have been experimenting with is four shillings an ounce, and of the sulpho-cyanide of potassium one shilling an ounce. Mr. Williams hopes, by some improvements in the method of producing it and increased demand, to be able to offer the former at half that price, or possibly, ultimately, a little lower than that; but so far as present evidence exists, it is impossible to state that it will ever become very cheap. Its purity is very important, and one of the most common impurities is a polysulphide of ammonium, which would be most fatal to the print. There is some hope, as stated by the French authorities, of producing it from gas residues, and Mr. Williams informs me that he has some on hand for that purpose; but even with this we fear that the cost of production, rather than of the materials, will be considerable. It is to be remembered, however, that when hypo sulphite of soda was first used in photography it cost three shillings and sixpence an ounce, and that even sometime after it was regularly used by professional photographers it cost a guinea a pound. Remembering these facts we may hope that if the new salts prove as satisfactory as we hope when further tested, they will soon be produced at a price which will be no barrier to their regular employment, and thus, possibly, introduce the era of permanent photographs.

ON THE DEVELOPMENT AND INTENSIFICATION OF THE NEGATIVE IMAGE.

BY VALENTINE BLANCHARD.

So much has already been said on this subject by those qualified to speak with authority, that it may appear superfluous, at first glance, to write further on a theme apparently exhausted. As, however, there is much in the individual experience of each experimentalist, that appears to clash with many of the preconceived notions, and as little points of detail are all important in the practice of the photographic art, I may be pardoned if much of what is here written prove simply a twice told tale.

Common place as appear the operations involved in the development of the negative image to those constantly engaged in the production of photographic pictures, there is no point in the whole photographic process where greater variety of results can be produced.

The employment of salts of iron in place of pyrogallie acid, has completely changed the character of the negatives. Instead of pictures of great depth, but lacking detail, we now have great softness in our pictures, but with it frequently a want of vigour. The great aim should be to combine the depth of the pyrogallie negative with the softness and detail produced by the iron salts. This is completely gained by most of the first class operators, but a great many of the pictures we see show a decided want in this respect.

It will be found that the cleanest pictures are produced by weak solutions of iron, and moderately large proportions of acetic acid, but the exposure is longer. A solution of 10 grains of iron and 20 drops of acetic acid to the ounce of water will give, with a 30-grain silver bath, negatives, which, while they develop slowly, yield prints of great roundness. With such proportions a moderately experienced operator can ensure wonderfully uniform results, as, in consequence of the slow development of the image, the employment of only ordinary care will produce clean pictures. It will be found also, that with the employment of a weak bath and the developer above mentioned, a considerable amount of

diffused white light may find its way into the supposed dark room, or in at the lens, without absolutely spoiling the negative, but with highly bromo-iodized collodions and with the bath and developer considerably increased in strength, the *slightest* trace of white light either in the room or lens, will very materially mar the beauty of the negative. The insidious influence of the light is so slowly felt, that the operator may easily be led to blame anything but the right cause. The unfortunate collodion or bath most frequently comes in for the blame. But where all these points are carefully attended to it will be found, that with a bath nearly neutral, of 35 or 40 grains, with a developer of iron 30 grains, acetic acid 15 minims, negatives of great beauty and depth can be produced, with an exposure altogether insufficient where weaker solutions are used, and, in many cases, these negatives will be found sufficiently dense, without any after method of intensification.

It may seem unnecessary to mention the importance of keeping out white light, but it is so easy to get into a jog-trot method of working, and make up the deficiency by some after process. A few days ago I was in the room of a friend who produces some really good pictures; I however found fault with the quantity of silver piled upon the image in many of his negatives. He replied that unless he did so the prints looked flat and wanting in brilliancy, and that the public found fault with them. On going into his dark room I was shocked at the amount of white light he permitted to enter. He, however, said it did not make any difference in his results. But I am satisfied, from the appearance of his negatives, that by stopping all the white light out he would get negatives that would print in half the time and be equally brilliant. Of course, if a negative very slightly veiled in the shadows be produced, it is so very easy, by a liberal use of silver in intensifying, to make up for it. But how much better to do away with the necessity for such a waste.

Very vigorous negatives can be produced by the employment of an extemporaneous acetate of ammonia in the developer. My method of operation is as follows: Of the iron 4 drachms are dissolved in 16 ounces of water, and into 4 drachms of acetic acid 1 drachm of liquor ammonia is poured. Violent effervescence ensues. As soon as this is over it is poured into the iron solution. With this developer I frequently secure negatives that require no after intensification.

It will be found of great service if a quantity of iron solution be made, but without adding the full quantity of acetic acid. Then pour out for the day's supply as much as may be needed, adding the acid to make up the deficiency, that is to say, if a developer containing 15 minims of acetic acid to the ounce be in use, add half only of the acid when the stock of, say a Winchester quart, is made. Then, if a pint be needed for the day's supply, 2½ drachms of acetic acid must be added before use. The acetic acid, when added in this manner, will be found to check the energy of the iron more completely, and enable the operator to produce cleaner negatives. It is a good plan also to make concentrated solutions of iron of known strength, and weaken at the time of use, adding the extra acid as above described. It will be found that while a strong solution is undoubtedly difficult to use, yet when skilfully poured over the plate negatives can be produced that need but little intensification.

Some time ago I advocated for intensifying the use of a solution of iodine, followed by pyrogallie acid and silver when needed after fixing. I have, however, found in practice that its use is dangerous, for frequently when large numbers are printed from the negative, it gradually blackens under the influence of the light, indeed to such a degree as to render negatives that were soft and harmonious when produced perfectly useless after six months' use. The same results have been noticed by Mr. Hughes, Mr. Williams, and others, when the bi-chloride of mercury, followed by iodide of potassium, has been employed. It would be desirable, if a preparation of iron could be employed as a developer,

* This sample, after standing several days in diffused light, without change, was placed in direct sunlight, when, in a few hours, it changed to a pale lavender tint, and has not gone further since.

which would permit the addition of silver when necessary without rapid decomposition. I have tried the addition of small quantities of glycerine and honey to the developer with varying success. If the bath contain no nitric acid, but a drop or two of acetic acid instead, it will be possible to employ a developer containing honey and glycerine, into which silver can be freely dropped. But at present I have not been able to employ it with uniform success. As, however, experiment in this direction is important, for there is nothing so beautiful as the negative developed completely with iron.

The nearest approach to this desired result is gained by the employment of a re-developer of iron, containing a liberal quantity of citric acid, say iron 5 grains, citric acid 10 grains. This solution, unlike pyrogallic acid, improves with age. Where a new bath is in use, as in instantaneous operations out of doors, and no alcohol is needed in consequence in the developer, the employment of this solution will effect a great saving in water, for no washing will be needed between the two operations. As soon as the image is developed by the ordinary iron solution, the image is washed, *if necessary*, or not, at pleasure, and then a portion of the re-developer is taken, and silver dropped in *ad libitum*. This is poured on and off until the requisite density is obtained. It will be found that the deposit is more delicate than that produced by pyro and silver. The negative is now washed and fixed in the usual way. When taken out in the light the image will be found of silver whiteness, and easy to be seen by reflected light. Indeed, it will be found to possess many advantages over the pyrogallic intensifying solution.

PHOTOGRAPHIC CHEMICALS.

THEIR MANUFACTURE, ADULTERATION, AND ANALYSIS.

Silica—(continued.) The combinations of silica with the alkalis are of the highest importance to all engaged in photography, inasmuch as these bodies enter largely into the composition of glass. The chemistry of the alkaline silicates is most complicated, and would be of very little interest to any of our readers, who would, doubtless, never desire to make their own glass, however perfectly our instructions for that purpose might be given. There is, however, a class of silicates which possesses interest in another direction. We allude to *soluble glass*, which, from its nature, is likely some day to be used extensively in photography. This product was first minutely examined by Fuchs. To obtain a good result, take fifteen parts of powdered quartz and ignite them with ten parts of crude potash and one of charcoal (which decomposes and expels the sulphuric acid contained in the potash), till perfect nitrification takes place. A good red-heat will be required for this purpose. The mixture must be put in a good Hessian crucible, not more than half filled, and the lid placed firmly on. The crucible is then to be put in a wind-furnace, if obtainable, or in a common fire, with a *blower* on, and exposed to a powerful heat from coke, until, on removing the lid, the contents are seen to be perfectly fused. The hard, blistered, greyish-black glass thus obtained is pulverised in a mortar, placed in a flask, and covered with its own weight of water. Heat is applied, and after half an hour, four more times its weight of water are to be added, and the whole boiled together for four or five hours. It will, if the operation has been successfully conducted, almost entirely dissolve in this time, leaving only a residue of impurities, carbonaceous matter, &c. Now filter the solution, and evaporate the clear liquid to a syrupy consistency. By simply drying the solution, the soluble glass is obtained colourless, transparent, and brittle, with a conchoidal, vitreous fracture, but softer than glass. It has a slightly alkaline taste and reaction, and after thorough drying still contains twelve per cent. of water. It is permanent in the air, does not absorb car-

bonic acid from it, and effloresces only when accidentally mixed with other salts of potash. In the fire it swells up from loss of water, then fuses, and forms an hydrous soluble glass. Dilute acids decompose it, with separation of silica, more easily than concentrated acids. It dissolves very slowly in cold, but readily in boiling, water, when in solution of a syrupy consistency, as obtained by the evaporation of the original liquid, soluble glass forms a tenacious, somewhat turbid, treacly liquid. On boiling or exposure to the air, it becomes covered with a tough skin, which disappears when thrust beneath the surface. After evaporation at a high temperature, it becomes very tenacious, and may be drawn into threads like melted glass. It dries up to a varnish when spread upon wood, &c., and the combustibility of which it diminishes. A dilute solution absorbs carbonic acid from the air—a concentrated one scarcely at all. The stronger acids precipitate silica from the solution, as do also alkaline carbonates, and many ammoniacal salts. Phosphate of alumina, and carbonate, phosphate, or sulphate of lead, when rubbed up with a solution of soluble glass, yield a tenacious mass, which becomes as hard as stone, when exposed to the air. The above properties of solution of soluble glass point out its great value to photographers in many respects. As a varnish it would be perfect, were it not for some little difficulties which are scarcely overcome at present, and which interfere with the uniformity of the film. Several experiments upon the employment of soluble glass are given in detail in our back volumes.

Glass consists of a mixture of silicate of potash or soda, or of both, with one or more silicates insoluble in water, such as silicate of baryta, strontia, lime, magnesia, alumina, manganese, iron, and lead. Pure silicate of potash or soda, or a mixture of the two, even with a sufficient quantity of silica to form a very infusible glass, would still be attacked by water and acids. Silicate of lime is likewise acted on by acids; but a mixture of it with silicate of potash or soda resists their action.

Such mixtures of silicate of soda and potash with silicate of lime, &c., are more fusible than the simple salts, and require a smaller amount of silica to render them capable of resisting the action of water and of acids. They contain between two and three atoms of silica to one atom of base, and still less when alumina is also present. The glass is more infusible and offers greater resistance to the action of water and of acids, the larger the proportion of silica and alumina it contains; it is more easily fused and attacked by water and acids the greater the excess of potash, soda, baryta, lime, magnesia, or oxide of lead which it contains; an excess of the last mentioned oxide renders it particularly fusible, of a high specific gravity, soft, easily scratched, and corroded by acids. Lead glass is also highly refracting, and on this account is of great service in the manufacture of lenses.

When water stands in contact with glass for some time, it extracts potash or soda from it, together with a portion of silica, the decomposition taking place with greater ease in proportion as the glass is richer in these alkalis, and more minutely divided, and the temperature of the water higher. The powder filed from white glass reddens moistened turmeric paper. Water triturated with pounded glass in an agate mortar becomes alkaline, and on the addition of sal ammoniac deposits flakes of silica. Water becomes alkaline after long digestion with glass at a boiling heat, and likewise turbid from separation of an insoluble compound of silicic acid and lime. An alkaline reaction is also exhibited by the powder of bottle-glass. After sufficient washing, it no longer reddens turmeric paper, unless it be recrushed in an agate mortar. These effects are much more striking with some kinds of English glass than with foreign glass, in which potash is generally employed as the alkaline base. It is for this reason, amongst others, that foreign chemical glass apparatus is so highly prized in this country, and Florence flasks are so frequently recommended for experiments in which solution or digestion at a high temperature is to be effected. In common glass, even the

moisture in the atmosphere produces an injurious effect. To this is due the annoying appearance in lenses, occasionally even by our best makers, known as sweating, caused by the atmospheric moisture separating out the potash and soda, and standing on the surface in a fine dew consisting of globules of alkaline solution. The silica and lime are left behind on the surface of the glass, and in time this decomposition causes the surface to exhibit prismatic colours. Sometimes this superficial decomposition is scarcely visible, but on warming the glass, numerous fine scales peel off, and leave the surface dull and opaque.

The pearly stratum with which specimens of antique glass found buried in the earth are covered consists almost wholly of silica.

Most acids attack glass, the action varying with the strength of the acid, and also with the quality of the glass—alkali being dissolved from it. Solutions of potash and soda also decompose glass, dissolving out the silica with greater ease in proportion to their temperature and degree of concentration. In some common varieties of glass, even at ordinary temperatures, the action is so strong that the glass sometimes cracks to pieces. When lead is present in glass, it tarnishes very readily by exposure to sulphuretted hydrogen. The dense glass used for prisms and lenses requires preserving away from this gas with great care, as it is acted on and darkened on the surface even by the ordinary atmosphere of a dwelling-house.

ON THE INFLUENCE OF SULPHATE OF SILVER IN THE SENSITIZING NEGATIVE BATH.

SULPHATE of silver is often contained in nitrate of silver made with nitric acid containing sulphuric acid. The solution of such nitrate, therefore, contains a small quantity of sulphate of silver which imparts to the bath the property of furnishing films more sensitive than if the nitrate employed had been purer; it gives quicker and more sensitive negatives.

If the quantity of sulphuric acid be too great, the sensibility remains, but the negative is spoiled by short lines resembling the letters of the Turkish alphabet and the characters used in stenography. These lines become fully visible only upon developing, and are caused by the absence of iodide of silver upon their path.

If the nitrate contains a greater quantity, it remains on the filter, for the sulphate of silver is but slightly soluble.

Failures due to the presence of sulphate in the nitrate are very frequent with the nitrate obtained from the residues of paper, filters, &c., treated as they are too frequently directed in books on photography.

The mode of treating then indicated by many writers must necessarily furnish a nitrate as rich as possible in sulphate of silver; to be convinced of this, it is only necessary to examine the prescriptions.

The papers are burned and the ashes placed in contact with liver of sulphur; sulphide and sulphate of silver are formed. The residue washed, decanted, then dried, is roasted to transform the sulphide into the metal silver.

To the last residuum nitric acid is added, then diluted with water, to be filtered.

What passes through the filter is the nitrate in solution accompanied with sulphate which is found in exact proportion to the water added.

This water evaporated, generally gives a nitrate containing from 5 to 10 per cent. of sulphate of silver; a nitrate quite unsuitable for negative sensitizing baths.

It is supposed that the sulphate may be separated by crystallizing the nitrate, but it is not; the sulphate crystallizes also, or is so completely in contact with the crystals of nitrate, that there always remains sufficient to cause the lines described above.

Method of treating Spoiled Nitrate Baths.

Baths are often put aside upon pretexts more or less well-

grounded, and every one knows that a new bath is always better than a doubtful one.

In order to obtain new baths without great loss, the following process will furnish excellent nitrate without much difficulty:—

The spoiled bath is filtered into a flat dish, in which a piece of pure copper is placed. After a contact of two or three hours (according to the quantity of the bath and the size of the piece of copper), all the nitrate of silver contained in the bath is converted into silver in the form of powder. The contents of the dish are filtered, then the silver powder is washed with several quarts of water poured upon the filter; this powder being dried, it will serve to make nitrate, taking care to keep it in a state of fusion for several minutes, in order to convert any particles of copper present into insoluble oxide.

The silver is in a very finely divided state; it is best to pour the nitric acid upon it in small quantities only, so that its action, which is sudden, may not cause particles of silver to be thrown out of the crucible.—*Bulletin Belge.*

GENERAL STUDY OF PHOTOGRAPHIC POSITIVES.

BY MM. DAVANNE AND GIRARD.

CHAPTER V., ON FIXING (CONTINUED).

§ VI.—On the Employment of Sulpho-cyanide of Ammonium.

BESIDE the three substances previously proposed for fixing positives, cyanide of potassium, caustic ammonia, and hyposulphite of soda, another has been recently introduced—a salt hitherto rare but of which many circumstances combine to render the manufacture abundant and cheap. This salt, which M. Meynier, chemist, of St. Barnabas, near Marseilles, has proposed and described the qualities, is the sulpho-cyanide of ammonium, or sulpho-cyanhydrate of ammonium.

The examination of the properties which can recommend this substance in an economical point of view, necessarily find a place in our "General Study of Photographic Positives." In order to render this study profitable, and to allow a comparison to be made of the qualities and defects of the salt in question with those of other fixing agents, we follow in this part of our task, the same method as with hyposulphite of soda, ammonia, &c.

Properties of the Sulpho-cyanide of Ammonium.—This is a white salt, crystallizable, decomposable at high temperatures, and extremely soluble in water and in alcohol. Considered in reference to the decompositions it can undergo by the moist way, this salt exhibits very remarkable conditions of stability in a fixing point of view.

For the substances which photographers have most to fear, with regard to the fading of their pictures, are, as we have frequently observed, free sulphur, sulphuretted hydrogen, or the compounds susceptible of producing them. Now, chemistry informs us, and we have verified it by new researches, that the reducing agents alone—nascent hydrogen, acidulated protosulphate of iron, &c., are susceptible of disengaging, in the state of hydrosulphuric acid, the sulphur of the sulpho-cyanides, but none of these agents intervene in positive photography.

Doubtless, the sulpho-cyanides are not stable; left for a considerable time in contact with the atmosphere, they deposit a yellow powder, sulpho-cyanogen, the formula of which is not yet fully established, but which we may consider as a sulphide of cyanogen with sulphur in excess. On the other hand, the alkaline sulpho-cyanides, treated with the concentrated mineral acids, or by chlorine, leave a deposit, either of sulpho-cyanogen in powder, or persulpho-cyanhydric acid in fine yellow needles. But the compounds thus obtained are themselves exceedingly stable, and do not, under the conditions in which photographic fixing is effected, either separate sulphur in a free state, or in the state of sulphuretted hydrogen. As to the sulpho-cyanides, such

as the sulpho-cyanide of silver, they present a surprising stability; this substance may be boiled with nitric acid; even calcined with nitrate of potassa, and, in those circumstances, decomposes only after a very prolonged contact with those reagents. Thus, from our present point of view, the sulpho-cyanides present themselves at once under very favourable conditions: the dilute mineral acids, the concentrated organic acids, very concentrated nitrate of silver, solid even, can never cause with the sulpho-cyanides a disengagement of sulphur, or sulphuretted hydrogen comparable, with that produced by hyposulphite.

Action of the Fixing Salt upon the Picture.—This established, the first question that presents itself is the following:—Can the sulpho-cyanide of ammonium remove all the argentiferous compounds? We have no hesitation in replying in the affirmative. For a long time it has been known that the alkaline sulpho-cyanides dissolve the salts of silver; this fact is recorded in all treatises on chemistry; but experiment has shown us that its solvent faculty is more absolute than that of the hyposulphite.

The action of this salt upon nitrate and chloride of silver is more decided, as every one may ascertain for himself. Take a solution of nitrate of silver, and pour into it some drops of the alkaline sulpho-cyanide, a white precipitate of sulpho-cyanide of silver will appear: upon your adding an excess of the reagent, the precipitate will quickly disappear. Chloride of silver, shaken into a solution of sulpho-cyanide, is dissolved in the same manner.

The clearness of these two reactions admits of our passing them over rapidly; we therefore devoted all our attention to the solution of albuminate of silver. We recognized that the solution was complete, and that the action of the sulpho-cyanide was, from this point of view, more energetic even than that of hyposulphite of soda. For, on the one hand, we precipitated some albumen by nitrate of silver; then, after well washing the precipitate with distilled water, we treated several times, one portion with sulpho-cyanide of ammonium, the other with hyposulphite. Again, well washed, the precipitates were then calcined: that which had been treated with sulpho-cyanide furnished traces of silver only; while that treated with hyposulphite of soda furnished very notable quantities. On the other hand, we fixed, comparatively, by means of these two agents, some albumenized papers, which we afterwards burned; and, in this case, we recognize a difference of the same kind quite favourable to the employment of the sulpho-cyanide, but which, we must say, was less marked than in the first case.

The sulpho-cyanide then attacks albuminate of silver more energetically than hyposulphite of soda, and, consequently, it presents a decided superiority over the latter with respect to the absolute fixing of the whites of the proofs.

Next to this first question we place a second no less important. The sulpho-cyanide of ammonium, when employed under suitable conditions, leaves on the proof no portion of its substance capable of change, either immediately or ultimately. In that respect it behaves like fresh hyposulphite of soda, but like the latter, it exposes the proof to some risk in the case where the manipulations have not been conducted with the necessary care. These dangers consist, 1st, in the precipitation of a small quantity of sulpho-cyanogen, either in the case where, by accident, some concentrated acid is present at the moment of fixing, or in the case where the bath full of proofs is exposed to contact with the atmosphere for an extreme length of time. 2nd, in a feeble quantity of sulpho-cyanide of silver remaining in the proof in consequence of incomplete fixing. In the first case, the bath, becoming thick, deposits a yellow powder, and the proof is immediately stained: in the second case, the sulpho-cyanide of silver, sensitive to light, quickly blackens; in both cases the photographer is immediately aware of what takes place, an advantage he is far from possessing with hyposulphite of soda, the injurious effects of which are not immediately developed, and in this particular the purchaser has an excellent commercial guarantee.

Limit of Saturation of the Sulpho-cyanide of Ammonium.—The study of this part of the subject, so complex with regard to hyposulphite of soda, is very simple with the sulpho-cyanide. Upon contact with the salts of silver, whichever they be, the alkaline sulpho-cyanides give rise to a white precipitate absolutely insoluble in water, the sulpho-cyanide of silver corresponding to the formula C_2NS, AgS . This salt combines with the sulphocyanide of ammonium to yield a double salt.

$C_2NS, AgS + C_2NS, NH_4S$, uncrystallizable in water, which it decomposes; but crystallizing with facility in an excess of sulpho-cyanide of ammonium. Isomorphous with this latter, the double salt always acquires a certain quantity in crystallizing, and we are thus able to obtain salts varying according to their composition from

$2(C_2NS, AgS) + 3(C_2NS, NH_4S)$

to that corresponding with the formula,

$C_2NS, AgS + 6(C_2NS, NH_4S)$.

Between all these there exists no other difference of properties than the instantaneous decomposition of the first by water, opposed to the solubility of the latter in a very minimum quantity of water, a greater quantity of this liquid rapidly producing an identical decomposition, and separating the double salt into soluble sulpho-cyanide of ammonium, and white in soluble sulpho-cyanide of silver.

This decomposition of the double sulpho-cyanide by water is, as we shall soon see, upon studying the practical conditions of fixing, a very serious inconvenience inasmuch as it compels the operator to submit each proof to two successive fixings, separated by a washing in water.

This property also brings notable variations in the limit of saturation of the solutions of sulpho-cyanide of ammonium of different degrees of strength, and it is very evident *à priori*, that an equal quantity of sulpho-cyanide of ammonium will dissolve much less of the salts of silver, of chloride for example, as the quantity of water in which it is itself dissolved is increased. This we have proved by direct experiment. For,

100 parts of sulpho-cyanide of ammonium dissolved in 100 parts of water, dissolve 26 parts of chloride of silver.

100 parts of sulpho-cyanide of ammonium, dissolved in 200 parts of water, dissolved only 19½ parts.

100 parts of sulpho-cyanide of ammonium dissolved in 400 parts of water, dissolved only 14¾ parts.

So that there is an advantage and economy in dissolving a given quantity of sulpho-cyanide of ammonium in as little water as possible.

Preservation of the Bath.—An important consideration which demands all our attention is this:—Do the baths of sulpho-cyanide deteriorate like those of hyposulphite of soda when they are charged with salts of silver? Experience has shown that a solution of sulpho-cyanide undergoes a similar change, whether it contains silver or not. Besides the compounds formed in it are not, in any respect, of a nature to injure the permanence of a proof; a small quantity of a yellow powder (sulpho-cyanogen) is precipitated, and the bath exhales a faint odour of cyanuret compounds.

A simple filtering will remove the sulpho-cyanogen which renders the bath turbid, but the cyanide of ammonium will remain dissolved. Perhaps this compound, the action of which upon the proof is necessarily energetic, may exercise some influence, good or bad, upon the proof. Of this, experience will instruct us, but what theory at present teaches us is, that a bath of sulpho-cyanide does not acquire, by becoming old, any element destructive to the proof. The stability of the compounds under consideration is such, that the fixing baths may even, without danger, be acidulated with acetic, tartaric, citric, and other acids.

*Practical conditions of Fixing.**—The proof, before being submitted to the bath of sulpho-cyanide of ammonium, must be washed under the same conditions as a proof in-

* If the proof be fixed after it is toned, it will be well to carry this a little further than ordinary, for the sulpho-cyanide of ammonium appears to attack the proof a little more than the hyposulphite of soda.

tended for hyposulphite of soda. By thus removing all the nitrate of silver, we economize the fixing salt, but that is the limit of the effect of washing; for, it must be remarked, that in this case, the presence of nitrate in excess does not present the same danger as when hypo is employed; a drop of a solution of sulpho-cyanide may fall upon a nitrated proof with impunity, for it does not spot it; the fingers impregnated with this fixing salt produce no marks or stains; in a word, there is nothing to fear of such accidents that so commonly accompany the use of hyposulphite of soda.

The proof is afterwards immersed in the fixing bath; the best conditions, it appears to us, are those of a bath of the strength of 30 to 40 of sulpho-cyanide to 100 parts of water. With a bath made in these proportions we can fix with 1500 grains of sulpho-cyanide, 3 or 4 sheets 16×20, previously washed.

The fixing takes place a little more rapidly than with hypo, five to six minutes in the fixing bath will be sufficient. At the expiration of this time the proof is removed from the fixing bath and immersed in a dish of plain water, then will appear the only inconvenience this new method presents; the double sulpho-cyanide with which the paper is impregnated becomes decomposed, and small quantities of this substance remain interposed in the substance of the paper. To diminish that proportion as much as possible, we must take the precaution of draining the proof on removing it from the fixing bath. A second operation is then necessary to cause the last portions of silver the paper retains to disappear; it consists in passing the proof into a bath like that first employed. On removal from this bath the proof is again washed in plain water, and if the latter remains untroubled, it indicates that the proportion of salt of silver removed by the second bath is so small in proportion to the sulpho-cyanide of ammonium, that the double salt is no longer decomposed by the water.

If, however, this decomposition manifests itself again after the second fixing (although we have never encountered this inconvenience in practice), we must proceed to a third similar operation. The quantity of silver introduced by the proof into the second fixing bath is so small that it may pass for a new bath, when the first has become saturated, and consequently may take its place, and serve for the direct fixing of washed proofs. This is an important consideration in an economical point of view.

Finally, we remove the last traces of the fixing salt by simple washings; these washings are much shorter than with hyposulphite of soda, and it is easy to recognize their limit by adding a drop of the salt of the peroxide of iron to the washing water, which, if the alkaline sulpho-cyanide be present, will produce a blood-red colour.

The sulpho-cyanide of ammonium, and the alkaline sulpho-cyanides generally, which, as we have recognized, behave exactly like the salt which M. Meynier proposes to employ, present important advantages, the principal of which are: 1st. The certainty of never producing sulphurous compounds, which gradually destroy the proofs; 2nd. The absence of all fear respecting spots on the proofs; 3rd. The probable preservation of the fixing bath. To these advantages M. Meynier thinks we may add that of the perfect innocuity of the sulpho-cyanides; but we cannot speak on this point, for we are perplexed between the assertion put forth by M. Meynier and the statement contained in all treatises on chemistry to the effect that hydrosulpho-cyanic acid is poisonous.

Beside these advantages we perceive only two inconveniences: 1st. The necessity of operating with two successive fixings, a necessity which, unfortunately, will cause many photographers to ignore the advantages of the new fixing salt; 2nd. The high price of the sulpho-cyanide, which, at present, render its employment too expensive; but we must not omit to remark that this inconvenience will soon disappear, for the processes employed, first by M. Meynier for extracting the sulpho-cyanides from the condensing waters of gas works, and, secondly, that proposed by M. Gelis, for manufacturing the cyanides by means of sulphide of carbon,

will soon admit of photographers obtaining the sulpho-cyanides at a price nearly as low as that of hyposulphite of soda.—*Bulletin de la Société Française de Photographie.*

THE NEW ART OF AUTO-TYPOGRAPHY.*

BY GEORGE WALLIS.

THERE are several methods by which the drawings can be made, but I shall confine my attention to describing and illustrating those which have been most successful up to this time. The material may be paper of suitable texture, such as fine India post, or sheet gelatine, or the drawing may be made on the surface of the plate to be engraved, or on the plate-glass bed of the machine.

When a drawing is made on paper there is a choice of two methods. One is to make the drawing with a glutinous ink, which, when apparently dry, will, by floating it upon the surface of water, or damping equally at the back, become so far wet again as to take up fine particles of emery or other hard granular substances reduced to a powder. The effects produced are bold and effective, but rather coarse, as the examples shown indicate. The other method is to make the drawing with the same material as that used in executing a drawing on sheet gelatine, on the plate, or the plate-glass bed of the machine.

These drawings on paper when engraved produce a tint all over the subject, the result of the texture of the paper itself. This tint may be very usefully employed in producing gradations of tone, when treated with a mezzotinto scraper and burnisher.

The material for executing the drawings on sheet gelatine, &c., presented the greatest difficulty and cost some hundreds of experiments. It is composed of peroxide of tin, peroxide of manganese, Indian or Venetian red, Paris white, rice starch, gum arabic, and bichromate of ammonia, the latter being used for the purpose of converting the gum and starch into an insoluble resin, so as to permit of the repetition of the touches of the drawing, without disturbing the work previously executed. The relative proportions of the ingredients of this drawing material, which requires special care and experience in its preparation, are given in the specification of the patent,† by which the invention has been secured, and therefore need not be quoted here, as, of course, modifications are made for the purpose of producing special effects, of which the practice of the art can alone show the use.

This drawing material is classified for use as No. 1, with which the outline and basis of the drawing is executed; No. 2, which is darker in colour, is used to re-touch parts requiring greater force than that produced by No. 1; No. 3 is sometimes used for producing very strong granular effects in the shadows, but generally I think it best to avoid its use.

One great peculiarity of this process is the production in the metal plate of the effects produced by broad washes and touches executed with a brush, somewhat of the character of aquatint. These broad effects are produced in the drawing by the washes being thrown in after the simple outline of the subject is obtained with material No. 1, by means of a special material, which, for convenience, is called Tint A, to indicate its use. A more granular modification of this mixture, Tint B, is used to obtain greater force in such parts of the washes as the artist may deem desirable.

The drawing instruments used are pens, metallic or otherwise, of suitable quality as regards fineness or breadth of point, and the ordinary sable brushes used in water-colour drawing.

When a drawing has to be executed, say on sheet gelatine, the material is selected of as even thickness as possible, and with the surface upon which the drawing is to be made free from spots, bubbles, or other blemishes, as these will come in contact with the plate during the operation of engraving, and all defects will be re-produced as well as the artist's work. The piece of sheet gelatine is mounted in a card board mount, the "sight" being cut to the size of the plate in which the drawing is to be engraved. (A specimen properly mounted was shown.) Over the back is placed a piece of tissue paper, fastened only on one side, so that it can be turned back, while the subject is traced upon the gelatine with the drawing material No. 1, from a study prepared for the purpose, and as the gelatine is as trans-

* Continued from p. 200.

† Patent No. 1,299, 1860.

parent as glass, of course this tracing can be done with the greatest nicety. The outline being secured, the piece of tissue paper is then returned to its position, and the drawing has much the appearance, when looked through, of being executed on ground glass.

To facilitate easy execution I have invented a drawing desk with a glass top fixed in a frame. This can be placed at any convenient angle, and by this desk being placed so that the artist can sit opposite to the light, with a piece of white paper on the bottom of the desk under the glass, the light is thrown through the partly executed drawing, and every facility is thus given for finishing it with all the force and effect of which the process is susceptible. (A specimen of the desk was shown in use with a lamp.)

The drawing materials, being in the condition of powder, are mixed for use by taking a small quantity of the gradation required and adding to it sufficient water to make it flow easily and continuously from the pen. If used too thin, however, the lines produced in the engraving are not forcible, and the principle of the invention must then be borne in mind, viz., that the lines will engrave in proportion to their substance, just as the natural object engraves according to the thickness and density of its substance. In this fact lies the whole condition of a successful drawing, and perhaps I could not give a better illustration than by reminding the artist that, as in oil painting, the impasto, or loaded portion of the drawing is in the lights, the reverse is the case in autotypography, for the deeper the shadow required the higher the relief of the drawing material should be off the surface of the drawing, as the greater will be the intaglio thus produced in the plate. Of course it would be hopeless to attempt to give precise rules for producing special effects. We are dealing with an art, and to know it it must be practised; and I believe that it has this merit, that the impress of the mind and manual dexterity of the artist will add to the great charm of the results produced, whilst the limit, under certain conditions, is simply that of the ingenuity and skill of the executant.

The drawing being ready for engraving, which it is as soon as dry—that is a few minutes after it is finished, although as a rule it is better to let it stand for a few hours—it is taken to the machiuo.

The machine now before you is a working model of improvements suggested by the experience gained in the construction of our four times the size, and by which the larger specimens have been produced. This consists essentially of a pair of rolls mounted on horizontal axes. The bearings of the lower roll are fixed, whilst the brasses of the upper roll in which it turns are capable of a vertical sliding motion in the side standards. By means of side screws and hand wheels the upper roll is raised or depressed. In this small machine the wheels are engraved with gradual degrees for the indices of pressure, which can be regulated to the 1520th of an inch by the usual relation between the rotation of the index wheels and the thread of the screws. The edges of these wheels are notched or toothed in correspondence with the graduated degrees, and a fixed index with a spring engages as the wheels are moved, thus indicating both the pressure and parallelism of the upper roll with the lower. Between the two rolls a horizontal table or bed, which is supported by steel spring bars, is made to slide. The table may be made entirely of metal, but in this instance it is made of steel with a well, into which a piece of plate glass is fitted and securely embedded upon a sheet of gutta-percha. The plate-glass possesses great advantages over metal, both as regards surface and non-oxidization, whilst the facility with which it can be removed, when required, from the well or metal frame for convenience in drawing upon is of great importance.

The rolls are made to revolve by means of a worm-wheel attached to the axis of the lower roll, but working outside the framework. Motion is communicated by a worm which drives the wheel, the power being applied to a hand-wheel or winch attached to the lower end of the worm axis or shaft, which works within a bearing and hanging bracket attached to the frame of the machine. The rotation of this shaft and worm communicates a slow and steady motion to the lower roll, and as this is geared on the opposite side to the upper roll by means of toothed wheels, the rolls rotate simultaneously.

The method by which a plate is engraved has now to be described. The thickness of the plate being gauged by one of Whitworth's decimal gauges, the indices are turned to the particular degree indicated by that thickness, with an allowance

of the 50th of an inch, and the thickness of the gelatine, which may be calculated at another 50th, as engraving pressure. It should be borne in mind, however, that the gelatine is elastic and yields probably full one-half its thickness, so that the *plus* pressure beyond the gauge of the plate may be taken at about the 30th of an inch.

The metal plates used are a good quality of Britannia metal, and, so far as experience goes, these print a fair number; but by taking advantage of Joubert's process for steeling the surface, or producing an analogous effect by means of nickel, the plates yield a considerable number of impressions; and, as the drawing is comparatively uninjured by the process, several plates of the same subject can be produced from one drawing by a careful examination of it, and a little retouching in such parts as may appear worn or deteriorated by the pressure in the operation of engraving. In some instances, as many as six plates have been produced from one drawing, and it is still available; and, unless injured by damp or some accidental cause, will be available for years to come.

It will be evident, from the nature of the process, that it possesses several advantages over any other in use for the reproduction of the artist's work direct from his own hand. Thus:—

1. There is no reversal of the subject required, as it is drawn exactly as it is to appear when printed.
 2. A plate can be engraved and proved to show the state of the drawing. The latter can be worked in again, and again proved, and this can be repeated until the desired effect within the limits of the process is produced.
 3. The transparency of the sheet gelatine gives great facility for copying drawings, by tracing all the leading features; and, of course, this applies to photographs, which may be largely used as guides, and art thus made to supplement science, since the artist has the power of selection in reproduction of the forms of the photographs by autotypography.
 4. The rapidity with which designs, drawings, &c., may be reproduced, when they are once executed by the autotypographic process, which, as already stated, becomes with a slight degree of practice, as easy as ordinary sepia or India ink drawing.
 5. The fact that the artist can retain the plate in his possession, and have such a quantity printed at a time as may best suit his convenience, as in the case of an etched plate.
- In all the illustrations given it must be distinctly understood that no after process, or any retouching whatever, has been used. All the examples are the result of the autotypographic process, pure and simple. It must be quite clear, however, that some of the effects could be rendered much more positive and telling by judicious touching up with the graver and etching needle. As, however, it would have been difficult to have defined where the process which is the subject of this paper ended, and that of touching up began, it was thought desirable that none should be shown which had been so treated. It must be clear, however, that for practical purposes those well known means of increasing the force of an engraved plate would be largely available when required.

There are only two points now to consider, and this paper may be brought to its conclusion.

The first is—Can the process be regarded as complete? To this I answer, as the inventor, that so far as the effects already attempted are conceived, it may be, but I feel satisfied that in the hands of an ingenious artist, fertile in resources as regards the production of delicate and even powerful effects, it is susceptible of very great development. This however depends upon one point, to which I am particularly desirous to have attention paid on this occasion in any remarks which may follow this paper, and that is, whether in the present advanced condition of the art of illustrative printing in its varied forms, this process is worthy of special attention and further development.

The second point is the purposes to which, if this question is settled in the affirmative, the process can be artistically and economically applied. Under the latter head we may range the reproduction of artists' sketches at a comparatively cheap rate, the plate being held for use at any period subsequent to the reproduction; also plates for book illustrations and the production of portraits in a metal plate by the aid of a photograph, the autotypographic drawing being worked upon from life, if necessary. The portraits so produced are, of course, as permanent as those printed from ordinary engraved plates. In the

industrial arts, the production of transfer plates, especially for the "bat" process for the decoration of porcelain, appears to afford a considerable field of operation, as the drawing produced by the original artist is reproduced on the ware; and outlines drawn by a first-class artist may be transferred to the surface of an article in porcelain, to be filled in with colour by the artist workman, whose technical knowledge is thus used to the greatest advantage. It must be evident, too, that metallic surfaces being planes, may be decorated in a novel and effective manner by painting upon the metal plate the design intended to be engraved, and then submitting it to the action of the machine. Results may be thus obtained which no engraving with a point could possibly achieve, and these effects may be further enhanced by working upon with the graver.

Of course it is impossible to calculate what ingenious persons may make of any invention at the outset. Experience has shown that the most unpromising in the beginning have come out triumphantly in the end; and it is equally true that many processes of apparently great value and probable usefulness when first developed, have sunk into oblivion before the test of practical and every-day application. Whether the process I have brought before the Society of Arts in this paper belongs to the one category or the other, it would be presumptuous to pronounce too distinctly in its present stage. I may be allowed, however, to state, in concluding this description of its purpose and leading features, that the main object I have had in view in following up a series of experiments extending over more than four years, at no little cost of time and money, has been the improvement of the arts of my country, both pictorial and industrial, by bringing the artist himself nearer to the reproduction of his own work, and affording a means by which the impress of the original mind and hand shall be conveyed in a permanent form, for easy reproduction in considerable numbers, at a comparatively cheap rate.

As a matter of interest to the members of the Society of Arts, I think it a duty, as it certainly is a pleasure, however largely mixed with sorrow, for me to state, that the late lamented President of the Society, His Royal Highness the Prince Consort, expressed a very distinct and favourable opinion of the process in its application to various branches of art, when specimens were submitted to him, and a desire to know more of the practical working than could be given by mere description; but his premature removal from his earthly sphere of usefulness prevented the fulfilment of arrangements proposed for meeting his wishes. We all know the intelligent interest with which he invariably investigated all matters which seemed worthy of attention, or likely to prove useful to the arts and sciences of his adopted country, and his readiness to encourage, by kindly words and judicious advice, efforts which he believed to be in the right direction. To myself, although greatly encouraged by the favourable opinion expressed, it would have been a source of infinite satisfaction to have submitted the whole process to the judgment of one so able to appreciate its value on the one hand, or detect its defects on the other.

PHOTOGRAPHIC PIRACY OF ENGRAVINGS.

(*Sittings at Nisi Prius, at Guildhall, before Mr. Justice Williams and Common Juries, April 27.*)

GAMBART V. MAYNE.

Mr. Collier, Q.C., and Mr. Brandt were for the plaintiff, and the Hon. G. Denman, Q.C., was for the defendant.

This was one of a series of actions brought by Mr. Gambart, of Pall Mall, the well-known publisher of works of art, with the view of endeavouring to protect his copyright in the engravings which from time to time he brings out. The plaintiff has for some time past confined his dealings to paintings of the highest character, and has given very large sums for works of merit. He gave £5,500 for "The Saviour in the Temple," by Mr. Holman Hunt, which is the largest sum ever paid for a modern picture. Having become the owner of a painting, he has it engraved in first-rate style and at great expense, and for the engravings, which are first-class in their character, he obtains from two to ten guineas each. Since photography was arrived at such a state of perfection, facsimiles of his plates have been taken by that process, and from the negatives so obtained copies are printed, which in some cases are little, if at all, inferior to the plaintiff's ten-guinea engravings, but which can be sold with profit for from 1s. to 5s. a-piece. A league has been formed by publishers of engravings for the purpose of putting

down this practice, but Mr. Gambart prefers suing on his own account, and single-handed.

In the present case, he complained of the infringement of his copyright in a very beautiful engraving, copies of which are to be seen in the windows of many dealers in engravings and prints, both in London and in the country. It represents our Saviour holding a lantern, and knocking at a rustic door, and is known by the name of "The Light of the World." The original painting is by Mr. Holman Hunt, and Mr. Gambart had expended upon the engraving, purchase of the copyright, &c., nearly £2,000. The defendant is a stationer and proprietor of a circulating library at Exeter, and photographic copies of Mr. Gambart's engravings having been seen in his window, in 1861, he was written to on the subject by that gentleman's agent, but no satisfactory answer was obtained from him. In October, 1862, Mr. Gambart having employed Mr. Bowen May to conduct his legal business, Mr. Wakeford May, who is clerk to his father, happening to be on a visit in the neighbourhood of Exeter, bought a copy of Mr. Gambart's "Light of the World" from Mr. Mayne, the defendant. Letters were written by Mr. May offering to forego all proceedings if Mr. Mayne would give up any copies remaining in his shop, and the names of the persons from whom he had obtained them, pay a small penalty, and promise to offend no more. No settlement could be effected and he therefore brought this action.

The plaintiff having proved his copyright in "The Light of the World," Mr. Thomas Ward, of Exeter, was called to show that he had bought two photographs of Mr. Gambart's engraving at Mr. Mayne's shop, and that he saw there about 10 other copies of the same print, but inasmuch as his purchases had not been within six months of the date of the commencement of the action, the plaintiff was limited in his proof to the photograph bought in October by Mr. Wakeford May, which was a very small one, much smaller than one bought by Ward. Mr. Gambart, however, said that the sale of even these diminutive copies was very detrimental to the sale of his engravings. He had exhibited the original painting in Exeter, and had, up to the time of the introduction of the photographic copies, realized there £800 by sales of his large engraving, but not a penny since. He urged it as his opinion that the public were satisfied with a photograph as a kind of reminiscence of the subject, especially when it was of a religious nature. In this view he was borne out by Mr. Graves, the eminent publisher, who said that a purchaser of the photograph had a small but exact reproduction of the original, and that in fact a photograph might be as large as the engraving of Mr. Gambart. Several points of law having been raised on behalf of the defendant, and reserved by the learned judge,

Mr. Denman addressed the jury and called his witnesses.

The defendant proved that he had sold no copies of "The Light of the World" since April last; that Mr. Wakeford May came into his shop in October and asked for a photograph of that engraving, and that he (Mr. Mayne) had told him that he had sold none lately, for that there had been a fuss about them. His daughter came in, and he said, "We don't sell 'Lights of the World,' do we?" and she answered, "No, certainly not." Mr. May then appeared very anxious to have one, and Miss Mayne said she thought she had a small copy, which had been given her by a Mr. Brewer. Mr. May said he should like to see it, upon which she went into a back room and brought the one which had been produced at the trial. Mr. May said it was a very poor one, and he would rather have a larger one. He then asked what he was to pay, and the defendant said "Nothing." Mr. May, however, insisted on paying, and eventually he did pay 6d., which Miss Mayne claimed. On this a Mr. Farrant, who was in the shop, observed, "Bravo young lady, I like to see you stick up for your rights." Mr. May bought three other photographs, and paid 3s. for them.

The defendant's evidence having been corroborated by Miss Mayne, Mr. Brewer, and Mr. Farrant.

Mr. Justice Williams asked Mr. Collier if he could carry the case any farther?

While the learned council was arguing the point, the foreman of the jury rose and said that there ought to be a verdict for the defendant.

Mr. Collier begged to say on behalf of Mr. Gambart that the defence had come upon him entirely by surprise. The defendant had not in his letters hinted at any such state of facts.

Mr. Justice Williams said Mr. Gambart was actuated by the most praiseworthy motives as he had a very valuable property to protect.—Verdict for the defendant.

Proceedings of Societies.

NORTH LONDON PHOTOGRAPHIC ASSOCIATION.

The usual monthly meeting of this society was held on the evening of Wednesday, April 22nd, at Myddelton Hall. Mr. G. Shadbolt in the chair.

The minutes of the previous meeting having been read and confirmed, the following gentlemen were elected members of the society:—Messrs. C. Wright, and C. Henneman.

Mr. COLLIS exhibited some views in Portugal, taken by Mr. Munro, an amateur, with Ross's panoramic and triple lenses. Also some fine card portraits, by Southwell and others, with his card lenses. Also a very fine photograph, 26 inches by 20 inches, of a *bas relief* in Spain, by the late Mr. Clifford.

Mr. G. WHARTON SIMPSON exhibited some very beautiful crystals of the double sulphate of iron and ammonium, by Messrs. Hopkin and Williams.

A conversation on the use of the double salt as a developing agent followed.

The CHAIRMAN showed some good stereographs from negatives by a new rapid dry process; and also some card portraits of celebrated men in America.

Mr. MORLEY showed some good negatives on Fothergill plates, treated after drying with a mixed solution of tannin and gallie acid. Some conversation on the subject followed, in which Mr. Morley, in reply to a question, said he thought that the gallie acid gave more intensity than tannin alone.

Mr. MAINWARING showed a stereograph of a wedding party, the negative of which was taken in four seconds. It was developed and intensified with iron, a solution containing 5 grains of iron and 5 grains of citric acid being used for intensifying.

Mr. G. WHARTON SIMPSON then read a paper entitled "Practical Notes on the New Fixing Agents," (see p. 206). The thanks of the meeting being awarded by acclamation, some conversation on the subject followed.

Mr. SIMPSON showed a number of prints fixed with the sulpho-cyanides of various tones, from purple-brown to black, in all of which the whites were perfectly pure. He also showed a sample of sulpho-cyanide of ammonium, and some sulpho-cyanide of silver in a test tube, which had been exposed some days to diffused light without change.

The CHAIRMAN said the paper suggested several important points for discussion. In the first place the fact that the new fixing agent did not present many advantages for removing the unaltered iodide from negatives was not of serious importance, as hyposulphite of soda performed that office so well already. Its use for fixing albumenized prints was of far greater importance; and here, for the present at least, they were met with somewhat contradictory evidence. If he understood Mr. Simpson rightly he found that even with this fixing agent silver was still present in the whites.

Mr. SIMPSON pointed out in some of the sulpho-cyanide-fixed prints exhibited the characteristic brown stain in the whites, produced by contact with sulphide of ammonium.

The CHAIRMAN resumed that Messrs. Davanne and Girard had said this salt was a solvent for albuminate of silver, and had also stated that the presence of silver in the whites of even hypo-fixed prints was due to some slight exposure to light, during the printing processes, and that if the same care were taken to keep the sensitive paper from all contact with white light which was taken with the collodion plate, we might avoid the traces of silver in the whites.

Mr. SIMPSON said that this was a very ingenious theory, but unfortunately for it Mr. Spiller's experiments quite disproved it. He excited albumenized paper, and then washed and fixed it with new hypo, without even taking it out of the dark room, or allowing it to have the slightest exposure to light. Yet this, when fixed and thoroughly washed, showed the presence of silver when tested with sulphide of ammonium, and yielded silver on analysis. In reference to the remark of Messrs. Davanne and Girard to the effect that the sulpho-cyanide of ammonium was a perfect solvent of the albuminate of silver, they had also remarked that after treating the combination of albumen and silver with this salt they found only very *small traces* of silver remaining. But if it were a perfect solvent no trace whatever should have remained.

The CHAIRMAN next referred to the possibility of testing for the final traces of sulpho cyanide in the fixed and washed prints, and said he did not think the iron test would be a sufficient

guide. Nitrate of silver was a very delicate test for hypo, but it was possible for the print to show no trace of hypo when tested with silver, and yet be imperfectly washed.

Mr. SIMPSON agreed with the Chairman that much stress could not be placed upon this test. But he thought that probably less danger was to be apprehended from traces of the sulpho-cyanide of silver remaining in the print than from traces of the hyposulphite of silver or soda. Either of the latter were very unstable, and free sulphur was liberated by their decomposition. This, it appeared, was not the case with sulpho-cyanide of ammonium or sulpho-cyanide of silver, for although sulphur could of course be liberated, it was much less liable to be so than from the other salts. It was possible that some danger was to be apprehended from the peculiar fact that the double sulpho-cyanide of ammonium and silver formed in the course of fixing, was decomposed by water into soluble sulpho-cyanide of ammonium easily washed away, and insoluble sulpho-cyanide of silver, traces of which would probably remain in the print. What damages must be apprehended from this, time would show.

The CHAIRMAN referred to the irritant influence of this and other fixing salts, such as cyanide of potassium on the skin, and remarked that he understood from a medical friend that it was rather from the potash than the cyanogen that the irritation arose, and that probably carbonate of potash would have a similar effect.

Mr. SIMPSON said that he had not referred to the irritation in the finger as any proof of the poisonous character of the salt. Authorities on that subject appeared to differ, and he had not made any experiments in that direction.

Mr. SIMPSON then placed a portion of the sulpho-cyanide of silver which had been exposed to light, in a glass, and pouring a little solution of sulpho-cyanide of ammonium upon it, showed how readily it was dissolved. He pointed out the advantage this offered in the case of imperfectly fixed prints, which, instead of being destroyed, could be properly fixed subsequently; and also showing that from this fact there was no danger of staining the print by touching it with the fixing salt as was the case with hypo.

Mr. MAINWARING asked if cyanide had been tried for fixing prints?

The CHAIRMAN said he remembered the same question being asked at the Photographic Society, when one gentleman replied: "He had tried it;" and, on being asked the result, laconically replied, "Out."

Mr. SIMPSON said the misfortune with cyanide was, that it did not discriminate between the unaltered chloride of silver and the reduced chloride which formed the half-tones, and these were generally destroyed by the cyanide.

The CHAIRMAN corroborated this view, and said that cyanide was not only a solvent for chloride of silver, but for metallic silver itself, when in a sufficiently fine state of sub-division, as in the half-tones of prints.

After some further conversation the proceedings terminated.

Miscellaneous.

PHOTOGRAPHS OF SANDRINGHAM, &c.—The London Stereoscopic Company have, during the last fortnight, had a staff of artists engaged at Sandringham in taking portraits of the Prince and Princess of Wales, and of the house and grounds. They have, we understand, been very successful.

TO EXTRACT THE SILVER OUT OF OLD HYPO BATHS, BY MEANS OF METALLIC ZINC.—If a strip or stick of zinc is put into an old hyposulphite bath the silver will precipitate in the form of a black powder. The reaction is complete when the liquid begins to smell strongly of rotten eggs (hyposulphurous acid). The liquid is then thrown away, and the deposit is washed repeatedly, to get rid of the hypo, and is usually thrown on to a paper filter and allowed to dry. This precipitate is not metallic silver, but a mixture of this metal with sulphuret of silver. It can, therefore, be transformed into nitrate by dissolving it in nitric acid. To transform this deposit into metallic silver, it is mixed with its weight of dried nitrate of potash in a porcelain mortar, and thrown by small quantities into a bright, red hot crucible. When the whole mass is fused, it is kept on a brisk fire for at least fifteen minutes. The silver will then be reduced, and the crucible allowed to cool. On breaking it, the metal is found in the bottom.—*American Almanac of Photography.*

Talk in the Studio.

COAGULATING ALBUMEN ON ALBUMENIZED PAPER.—Mr. Wood says, in reference to the alleged difficulty which some have felt in effecting coagulation by steaming, that in his hands it is so simple that he would undertake, unassisted, to complete a ream in three hours, and warrant every inch perfectly insoluble.

MEDALS OF THE PHOTOGRAPHIC SOCIETY OF SCOTLAND.—Amongst the medals awarded by the Scottish Society for meritorious works at its recent private exhibition, we find that Mr. Meagher has secured one for excellence of workmanship and improvements in cameras. Also, that for printing in carbon, the committee would recommend that the medal be given to Mr. Pouncy, of Dorchester, for his view of Melrose Abbey, in which it appears to the committee he has overcome the difficulty of representing in carbon every variety of shade and tint exhibited in the original negative.

THE CAMERA FOR THE LANCASHIRE FUND.—We understand from Dr. Diamond, that the subscription list, making a hundred chances, at five shillings, for Mr. Meagher's handsome camera, given to the Lancashire Fund, is not yet quite filled. As the drawing will take place shortly, the Secretary is anxious to have the list filled up, and also to receive the subscriptions of those who have already entered their names. We commend the matter to the attention of our readers.

To Correspondents.

G. R. G.—The defect is that so commonly known as mealiness; it proceeds from a variety of causes, the majority of which originate primarily in some peculiarity of the paper or albumenizing. It may frequently arise in comparatively good paper from unsuitable treatment, and in some samples no treatment that we know of will entirely avoid it. A strong neutral or slightly alkaline silver bath, a good negative, well washing in distilled water, and slow toning with a gold bath at least a few days old, are the best modes of avoiding the evil. Some printers have found great advantage in bad cases from the use of a bath of acetate of soda previous to toning. We have never found it, when we have toned slowly, using a dilute acetate and gold bath, which has been made a week or more. In your case, from the results, we imagine the toning has been rapid. Where it shows before toning, it results either from the paper, or from an acid nitrate bath.

N. O. B.—We have never met with, or heard of, anything like the stained and leprous effect of the sensitive paper enclosed in your letter. If it simply result from floating on the nitrate bath without contact with any other substance, we cannot conceive the cause. The paper must have come into contact with some other chemical beforehand. The contact of salted albumen only, with nitrate of silver, could not produce such a result. It might possibly arise from some serious impurity in the paper.

PHOTOS.—The addition of three grains of carbonate of soda to one grain of chloride of gold, will frequently be sufficient to cause precipitation in 24 hours. We do not like the use of carbonate of soda on account of its uncertainty. Carbonate of lime being an insoluble alkali, answers the purpose of neutralizing much better. See a short article on the subject in the present number.

P. T.—Your communication must have miscarried, as we always answer or acknowledge in some way the receipt of letters, and we are always glad to receive suggestions which may be of service to our readers. Exposing an excited wet plate to the fumes of ammonia would, unless the bath were very acid, produce fog. It is a dangerous practice to keep chemicals of any kind unlabelled, especially composite acids. There are various methods of distinguishing between nitric, sulphuric, and hydrochloric acids. The presence of colour is not a test; when pure they are all colourless, but all assume colour from the presence of impurities; the yellow colour is most likely, however, to belong to the hydrochloric acid. Perhaps the simplest method for you to ascertain which acids the three unlabelled bottles contain will be to observe the following points: the nitric and hydrochloric acids both emit suffocating fumes, when the bottle is opened the sulphuric acid does not. To distinguish then between the two first, add a drop or two of each to a solution of nitrate of silver, with the nitric acid no visible change takes place; with the hydrochloric acid a white curdy precipitate of chloride of silver is thrown down. As a further test for the sulphuric acid, add a little to a solution of nitrate of baryta; a white insoluble precipitate of sulphate of baryta is the result.

A. FAIRBANKS.—You cannot secure a copyright in the portrait of one of your sitters without an agreement with him to that effect.

J. J. W., Eton.—Your cards have very good qualities. There is, however, a little too much even diffusion of light all round the figure. A little more direct light from one side, and a little more shadow on the other, will give you more force without losing definition. We are glad you have found our teachings so valuable.

H. P. C.—You will find various descriptions of developing boxes for field use in our back volumes. We may especially mention page 275, Vol. v. (No. 144), and page 381, Vol. v. (No. 153). A good portrait lens, when used with full aperture, does not possess much depth of focus, especially when used for objects very close at hand. To get depth of focus you must use a small stop, and in such a subject as that you name, you can afford to do so, without reference to the time of exposure. A still-life object, such as a group of porcelain, should be taken with the lens sufficiently stopped down to give the proper modelling and definition in every part. The simple lens

of the same maker is the best for such work, giving great depth of definition; but if you wish to work with your portrait lens, you will have no difficulty in obtaining depth of focus if you use a smaller stop.

M. A.—Unless the sample of chloride of gold be nearly neutral, the trace of alkalinity in acetate of soda will be insufficient to neutralize the acid. The free hydrochloric acid will decompose the acetate, and become neutralized by the soda, leaving free acetic acid. See our short article on the subject in the present number. The tone and general qualities of the print you enclose are very satisfactory.

A. B. C.—Thank you for the slip. As you would perceive in our last, we had already received and made use of it. Your bath is super-saturated with iodide or iodonitrate of silver. Dilute it with half its bulk of distilled water, which will at once make it milky-looking, place in the sun for a few hours, until the precipitate has fallen and the solution is clear; now filter, and then add sufficient nitrate of silver to make up the proper strength. The print received is from an under-exposed negative. If it had received longer exposure it would be brighter and more harmonious.

P. M.—So far as we know, No. 2, but we do not speak from personal experience. Either of the English, we believe, are superior to the French lenses.

W. H. H.—There is some difference in the solubility of different samples of tannin; but we have not met with any which did not with proper agitation dissolve in the ratio of 15 grains to an ounce of water. There is often a slight deposit of resinous matter which must be removed by filtration, after which it may appear opaline, but not turbid. In preparing gum and tannin it may be better to dissolve and filter each separately, and then mix. We cannot tell you where to obtain malt except from a maltster or brewer. Prepare it by infusion, using three or four ounces of malt to a pint of boiling water.

CUMBERLAND.—The chief fault in the card sent arises from the fact that both the sitters, or the plate, have moved. In the next place the negative is considerably over-developed, and the print not sufficiently deeply printed. Even when operating in the open air you should contrive some means to obtain shadows. The light is equally diffused all around your sitters, which destroys force and modelling. Read a recent article headed "Amateur Portraiture."

A LADY AMATEUR.—The red streaks on the prints in your letter are apparently due to imperfect albumenizing of the paper. The albumen appears to have run in streaks, and those parts where it is most present refuse to tone.

A CONSTANT SUBSCRIBER.—The plate commonly used for the stereoscopic negative is 6½ inches long, and it is customary, in the absence of any instructions to the contrary, on the part of camera makers to place the lenses on a bi-lens camera at a distance of 3½ inches from centre to centre. This is a very good distance, as, when the print is produced, each half can be trimmed all round, which, if the images were much nearer together, could not be done. The distance should never be less than 2½ inches apart, and may be a little more without disadvantage. According to strict rule, as stated by some authorities it should not exceed the distance between the eyes, whilst others would regulate the distance according to the character of the view, making it, for very distant objects, several feet apart. We think the latter in error, but it is not necessary to adhere absolutely to the former.

DUTIES OF A PHOTOGRAPHER'S APPRENTICE.—A correspondent familiar with the law writes as follows:—"As you have said, 'W. R.' cannot legally enforce the apprentice to learn a different profession to the one which is mentioned in the indenture. It is very evident from the wording of the indenture—and particularly from the fact that no mention is made in it of painting photographs—that 'W. R.' is bound to teach his apprentice the art of a photographer and not that of painting photographs; and the apprentice would be perfectly justifiable in refusing to do anything but what is stipulated in the said indenture. Of course this opinion is grounded upon the supposition that the wording of the deed is in no respect different from what 'A Constant Reader' uses in his recital of it. If the indenture states that 'the apprentice shall be taught the art of photography and its branches' the master is at perfect liberty to teach and enforce the teaching of his apprentice in anything which relates to photography."

W. STONEHOUSE, Whitby, sends us some very charming card portraits, taken with Dallmeyer's No. 2 B lens. They are beautifully defined, round, soft, and delicate. The lighting is very successful, and the composition generally good. No. 6, a young lady in profile, lighted chiefly from behind, is very fine. The fish-woman is a good photograph and characteristic picture. No. 4 is a good photograph, but as a composition it is cut up into two parts a little too definitely by the curtain, &c. No. 2 is a capital composition. As a whole we like the pictures much.

A. WOOD.—We are obliged for the prepared paper and further details. We hope to try it in a day, and will report with what success. The specimen enclosed is very good. Several correspondents in our next.

Photographs Registered during the Past Week.

- MR. A. BROTHERS, 14, St. Ann's Square, Manchester,**
Photograph of 'The Members of the Session of the Presbyterian Chapel, Copland Street, Manchester.'
- MR. A. S. WATSON, 2, Regent Road, Great Yarmouth,**
Photograph of Rev. Gott.
Photograph of Rev. Neville.
- MESSRS. W. ANN D. DOWNEY, 9, Eldon Square, Newcastle-on-Tyne,**
Eight Photographs of Fishing Scenes, with Portraits of Lords Thynne, Dunglass, and Kerr.
Two Photographs of Elihu Burritt, Esq.

Advertisements and Communications for the Publisher for the current number, to be addressed to the Office, 32, PATERNOSTER ROW, not later than 3 o'clock every Thursday. Post-Office Orders are to be made payable to Mr. THOMAS PIPER, at the Money-Order Office, St. Martin's-lane.

THE PHOTOGRAPHIC NEWS.



Vol. VII. No. 244.—May, 8, 1863.

CONTENTS.

	PAGE
Experiment with Iodides and Bromides in Collodion	217
The Enamel Photographic Papers.....	217
Copyright in Engravings.....	218
Formic Acid in the Developer	218
Critical Notices	219
The Double Sulphate of Iron and Ammonium as a Developer.	
By H. S. Noverre	219
The New Fixing Salt. By Dr. Van Monckhoven.....	220
On Developing with Pyrogallic Acid. By M. L'Abbe Laborde... 220	

	PAGE
Authenticated Formulæ	221
Proceedings of Societies	222
Photographic Piracy of Engravings.....	224
Correspondence, Foreign Science, &c.....	224
The International Exhibition—Report of the Jury	227
Talk in the Studio	228
To Correspondents.....	228
Photographs Registered during the past Week	228

EXPERIMENT WITH IODIDES AND BROMIDES IN COLLODION.

In conducting experiments all the conditions at every stage of which are well known and familiar, the experimentalist is apt to be guided in his estimate of the result by foregone conclusions. It is well, therefore, sometimes to begin *de novo* without a knowledge of some element in the calculation, so as to reach conclusions without any settled conviction in the mind of what must happen.

A few days ago a manufacturer of collodion sent us three sample bottles to report upon. They were labelled No. 1, No. 2, and No. 3, but no clue of any kind to their special character or preparation was given, beyond the fact that they were especially intended for card portraiture, and that the manufacturer was desirous of having independent testing or verification of his own results before making largely for the public. He felt, therefore, that a report, unbiassed by any possible prepossession, would be best obtained by withholding any details as to haloid salts, and their proportions, present in each.

We proceeded to take a card negative with each, exciting in a nitrate bath in excellent condition, giving us fine results with various samples of collodion we had in use. We used a Dallmeyer's No. 1 B lens, with a stop of about half an inch aperture, giving in each instance, five seconds' exposure in the open air. We developed with a strong solution of saccharo-sulphate of iron. The result of the first trial of each sample, hastily jotted down at the time, but verified by repeated experiments since, was as follows:—No. 1, lights developed quickly, but half-tones appeared tardily; finished image thin, grey, and under-exposed, with fogged shadows, profusion of spots, and comets. No. 2 developed in every way satisfactorily, the image was brilliant, the high lights well picked out, the half-tone delicate, and giving great modelling, shadows clean, the negative sufficiently vigorous, with the first application of the iron solution, to print well without further intensification. No. 3: the result was in many respects similar to those of No. 2; a very soft image, but sufficiently dense to print without further treatment; a little more deposit on the shadows, and the general effect of being a little more done, the sparkling high lights giving force and brilliancy in No. 2, being wanting in No. 3.

On rendering this report to the maker of the collodion, we learnt that in each instance the normal collodion was the same, the sole difference being in the salts used, which were as follows: No. 1 contained $4\frac{1}{2}$ grains of iodide of cadmium in each ounce. No. 2 contained the same quantity of the same iodide, with the addition of one grain of bromide of cadmium. No. 3 contained the same quantity of the same iodide, but in addition $4\frac{1}{2}$ grains of bromide of cadmium to each ounce. The results in his hands had been similar to those in ours, with one interesting difference, illustrating another point: No. 1 in his hands was less sensitive and less satisfactory than the others, but instead of yielding a

thin grey image, it gave a negative with great density and contrast, but without half-tone or harmony. The difference in the experience of each was easily explained. We had used a bath somewhat freely acidified with nitric acid, whilst he had used a neutral bath. The presence of nitric acid in the bath was, in the days of simply iodized collodion, a familiar cause of thin grey negatives, and proved so in this instance. Some subsequent experiments with a neutral bath gave us similar results as to sensitiveness; but whilst with No. 1, the simply iodized sample, we then got rid of the thin grey image, it was still spotty and slow, and yielded less brilliant prints than a negative taken with No. 2 under similar circumstances.

The results thus secured, and the conclusions attained, without the possibility of foregone convictions influencing the decision, confirms in a very satisfactory manner all our established conclusions, the results of numerous carefully conducted experiments several years ago, and repeated at intervals since. For portraiture and general purposes a collodion made from cotton which will dissolve not less than six grains to the ounce of solvents, and containing from a grain to a grain and a half of a bromide, and from four to five grains of an iodide, either cadmium alone, or half cadmium and half an alkaline iodide, we regard as decidedly the most stable and best for iron development, yielding, with short exposure, harmonious and brilliant negatives. For many special purposes a larger proportion of bromine may be permitted, for the general purposes of the portraitist, however, it is unnecessary and sometimes injurious.

THE ENAMEL PHOTOGRAPHIC PAPERS.

As the enamel papers for card portraiture appear likely to excite some interest amongst photographers, it is important to obtain as much information as possible as to their original preparation, the treatment they require, and the qualities they possess. At present the information on the subject is very scanty, owing to the existence of "trade secrets;" we have, however, gleaned a few additional particulars.

There are, so far as we know at present, three distinct manufacturers of the enamel photographic paper all in Germany, namely, Liesegang, Schering, and another whose name we do not at this moment recall. Of the material employed in giving the preparatory enamel surface we only know that employed by Herr Liesegang, the other two houses preserving the matter a secret. Herr Liesegang, himself an able photographer and chemist, knowing the importance to the photographer of having some knowledge of the nature of materials with which he is working, does not withhold the information. The pigment employed in enamelling, he informs us, is oxide of zinc. Referring to the suggestion, in the letter of a correspondent, recently made in our columns, to the effect that his paper was really prepared by Mr. Schering he writes as follows.—

"The paper of which I sent you a specimen was prepared,

after my suggestion, in the manufactory of my father. The enamel is a preparation of zinc-white, and the albumenizing is done in the ordinary manner. The albumenizing not being different from that of ordinary paper (the solution being only a little more salted because the film is entirely on the surface) there is no reason why it should be treated in any other way."

The samples we have seen of the three makers vary in qualities. That of Liesegang has a less highly glazed surface than either of the others, but it is more free from tendency to crack, and, altogether, presents the fewest manipulatory difficulties. In fact, we have treated it as precisely ordinary albumenized paper, and found no difficulty whatever in obtaining excellent results.

The sample with the highest surface was that we received from Mr. Jocelyn, details regarding which we recently published. The quality was very fine, but it required great care in treatment to avoid cracks.

The paper, prepared by Schering, which he styles alabaster paper, not enamel, takes a position midway, both as to surface and as to facility in manipulation, between the last mentioned and that prepared by Liesegang. We have recently received communications on Schering's paper, both from Mr. Spencer and from Messrs. Johnson and Matthey. We glean from them that the first sample of this manufacture which arrived in this country was somewhat prematurely introduced, before its manufacture was sufficiently perfected, and that a judgment formed on such a sample will scarcely do it full justice. We have received a sample of a fresh arrival, to which we have not had time, however, to give a fair trial. One of the claims made for the alabaster paper is that it does not crack under fair treatment. We must warn our readers, however, that unless pinned at the four corners when lifted from the silver bath, it will curl and will crack. Indeed, the sample which reached us, rolled up, was already slightly cracked, and would have been better if it had been set out flat. The tendency to crack seems to increase with the proportion of the enamel pigment present, and hence the thinnest papers, with least of the enamel pigment, present the least difficulty. We have tried the sample in question, so far as to be able to say that in our hands it has not given the streaky effect, nor the bloom in the shadows, which we have heard alleged as being present in the first sample by the same maker.

From all we can learn, it appears that some slight specialities in treatment are required by the alabaster paper in order to secure the greatest success. Mr. Schering recommends the following formulæ:—

FORMULA FOR TREATING THE ALABASTER PAPER.

Silver Bath.

Nitrate of silver	80 to 85 grs.
Distilled water.	1 oz.

The bath must be rendered acid, so as to quickly reddens litmus paper.

Floated the paper for about five minutes after printing, until the shades become bronze coloured; wash in several waters, in the last of which put a little acetate of soda.

Toning Bath.

(Sufficient for six sheets.)

Chloride of gold.	15 grs.
Bi-carbonate of soda	150 grs.
Distilled water.	36 oz.

And it is advisable to add—

Citric acid	15 grs.; or,
Acetate of soda	1 oz.; or,
Phosphate of soda	1½ oz.

in order to get the desired tone.

Fixing Bath.

Hyposulphite of soda.	1 part.
Carbonate of soda	½ "
Water	8 "

We have not tried the formulæ given; but we should distrust the large amount of bi-carbonate of soda prescribed; a fifth part of it would be, in our estimation, nearer the mark.

COPYRIGHT IN ENGRAVINGS.

WE call the attention of photographers to a decision of the Court of Common Pleas, Lord Chief-Justice Erle, and Justices Willes, Byles, and Keating sitting in Banco, on Saturday last. The Copyright Acts relating to engravings give to the proprietors of such copyrights the sole right to reproduce or copy in any manner whatever the engravings protected by the provisions of the Act. The phraseology employed appears to us very comprehensive: it says distinctly that the engraving shall not, without permission of the owner of the copyright, be "engraved, etched, or worked in mezzotinto or chiaroscuro, or otherwise, or be in any other manner copied in whole or in part," &c. To common apprehension this phraseology would cover every possible mode of copying, photography not excepted. The law is said to be the perfection of reason; but certain acute lawyers have held that, as photography was an art unknown at the time when the Act was formed, and could not, therefore, be contemplated or comprehended by its provisions, and that therefore photographic reproductions were not copies within the meaning of the Act.

In a recent case, which we reported, a verdict—damages £10—was obtained by Mr. Gambart against a photographer for pirating the engraving of "The Horse Fair;" but a rule was obtained to set aside the verdict, on the ground to which we have just referred—that photographs were not contemplated by the Act, by virtue of which Mr. Gambart possessed his copyright. The hearing of the case took place on Saturday last, and we are glad to record that the decision of the Judges was to the effect that the law in this instance was in accordance with common sense and common honesty. Mr. Justice Erle referred to the very comprehensive words of the Act, which included, any manner of copying, and this applied, in his opinion, not only to the modes of copying then known, but to any other mode which the ingenuity of man or the progress of science should develop.

We are glad that this question has been brought to a decision, because we regard everything like dishonesty, meanness, or piracy, associated with any branch of our art or its professors, as degrading it, and all belonging to it, in the eyes of the public generally, and we trust that this decision will tend largely to put a stop to the illegal piracies which have so frequently been brought under public attention of late.

FORMIC ACID IN THE DEVELOPER.

[We have been favoured by Mr. Henry Claudet with the following copy of a letter addressed to the *Moniteur* in answer to Dr. Van Monckhoven's article on the use of Formic Acid in the Developer, which was reproduced recently in our pages.]

MY DEAR SIR,—The last number of the *Moniteur de la Photographie* contains the result of some experiments made by Dr. Van Monckhoven, which are not favourable to the employment of formic acid, as described in the process I indicated in the *Photographic Journal* of the 15th of July, 1862 (and in the *Photographic News* of July 18th), which was communicated to the Academy of Sciences by Mr. Balard subsequently.

Such a communication made by Dr. Van Monckhoven, who is considered as an authority in photography, will probably discourage many persons disposed to try a process which ought to contribute to the progress of instantaneous photography, generally regarded as the highest aim of all engaged in this art. I believe it to be my duty therefore to ask you to publish my reply to the conclusions of the photographic *savant* in question. Dr. Van Monckhoven says:—

"The negative developed with pyrogallic acid mixed with formic acid, appears quickly, but the formic acid does not retard the reduction of the silver, producing on the film a greyish deposit of silver."

This result shows me, that Dr. Van Monckhoven has used too much formic acid, or that his acid was too strong to be introduced in the formula in the proportion that I have indicated.

In fact, in the course of my experiments, I have also had the deposit of silver of which Dr. Van Monckhoven when the dose of formic acid has been too strong.

When the collodion plate has been withdrawn from the nitrate of silver bath, *decidedly acid with nitric acid*, and well drained before putting in the slide, then exposed it in the camera, and a solution of pyrogallic acid mixed with formic acid applied, the image appears instantly, giving a very vigorous negative; and, however far the development be pushed, there should be no reduction of metallic silver upon the plate.

It is necessary that the exposure in the camera should be five times less than if developed with pyrogallic acid and acetic acid; and half the time necessary where it is developed with the sulphate of iron; having moreover the advantage over the latter that there will be no necessity for intensifying. If this result be not obtained, the most probable cause will be that the formic acid has been too strong. This should not, of course, discourage the experimentalist, but simply induce him to continue changing the proportion of formic acid in the developer until he gets the results I have obtained daily for two years, and of which I am able to show the proof in the large photographs and the cartes de visite sent by my father to the exhibition of the "Palace of Industry," all of which have been done by my process.

Having had the occasion to operate before M. Balard in his last visit to London, this illustrious *savant* was so much surprised at the rapidity of photogenic action resulting from the new addition of formic acid in the developing bath, that he himself proposed to me to present the communication of my process to the Academy of Sciences, as a discovery capable of rendering service to photography.

I have frankly described the process with the desire of rendering it easy to all operators, and the formula that I have given succeeds with me perfectly. I recommend Dr. Van Monckhoven to make new experiments. I need not say to him that the state of the nitrate bath, more or less acid, the constitution of the collodion and of the pyrogallic acid that he used, and, perhaps, the quality of light under which he operated, may cause a modification in the proportions of formic acid necessary. He will, I think, be soon convinced that formic acid, added to the developer, is attended with the best results, as an accelerating agent, the most powerful in the formation of the photographic image.—Yours very truly,

HENRY CLAUDET.

Critical Notices.

THE FAITHFUL SHEPHERDESS: A Statue, by Miss S. D. DURANT. Photographed by STEPHEN THOMPSON. London: MARION & Co.

We unhesitatingly affirm our conviction, at the risk of the double charge of bad taste and want of gallantry, that the photography is here, in our view, better than the sculpture. The figure is one of a series of colossal statues executed for the Corporation of London, amongst which are some fine productions by good men. "The Faithful Shepherdess" is in illustration of Beaumont and Fletcher's lines, running thus:—

"Look and see
The ring thou gavest me, and about my wrist
The curious bracelet that thou thyself did twist
From these fair tresses. Know'st thou Amoret?"

The expression and pose of the statue—which may now be seen in the Royal Academy, where we examined it—illustrate the lines sufficiently well; the drapery is also graceful, but the general effect of face and figure is "sticky," poor, and hard. Miss Durant, who is, we believe, a pupil of the Baron Triguetti's, holds a good position in a certain school of sculpture, and it may be heresy to express our want of admiration for the work; but it is so. Mr. Thompson has chosen a view which gives the best rendering to the subject and produces a really fine picture (12 by 10), which Her Royal Highness the Crown Princess of Prussia—we like the term Princess Royal of England better—for whom the work was photographed, has not only expressed her gracious approval of, but given permission for its publication.

We have received some fine things Mr. Thompson has recently been executing in Warwickshire, which are not, however, ready for publication yet.

THE DOUBLE SULPHATE OF IRON AND AMMONIUM AS A DEVELOPER.

BY H. S. NOVERRE.

I HAVE been using the double sulphate of iron and ammonium for the last two months, and as its employment appears likely to become general, I send you the formulæ I have found most useful. The advantages I find it to possess over the protosulphate of iron are the absence of all tendency to deposit on the shadows, that a shorter exposure is required in the camera, that the crystals keep well, and that, provided the solution has not been kept long, it may be mixed with solution of nitrate of silver, without becoming turbid, for several minutes.

The following is my experience as regards the strength of the solution:—

Sulphate iron and ammonia	25 grs.
Acetic acid	15 mins.
Water	1 oz.
Alcohol	q. s.

The above is a convenient solution for general use for views and portraits well lighted, and it keeps well.

Sulphate iron and ammonia	35 grs.
Acetic acid	20 mins.
Water	1 oz.
Alcohol	q. s.

This solution I have found useful for subjects badly lighted and for interiors, but is too energetic for ordinary work. I enclose a carte de visite, the negative of which was developed with this solution; the image started out at once, and after applying the developer, and in about two minutes, was of sufficient density to require no further intensification. The exposure was two seconds, with Dallmeyer's No. 1 B lens, with the X stop, in the open air. I do not think, however, that the result is as satisfactory as if it had been developed with the first-named solution, and intensified afterwards with pyrogallic acid.

A stronger developer is made thus:—

Sulphate iron and ammonia	100 grs.
Acetic acid	30 mins.
Water	1 oz.
Alcohol	q. s.

It answers very well for instantaneous work; it develops clearly and evenly, and is at the same time quite under control. This is best used fresh, as it may then be kept on the plate several minutes if the picture does not appear at once.

The solutions of the double salt do not appear to keep any better than those of the protosulphate of iron, but the crystals keep exceedingly well. I have had some of the salt loosely wrapt in paper for about two months, which is as good as the day it was bought.

25, South Street, Park Lane.

THE NEW FIXING SALT.

BY DR. VAN MONCKHOVEN.

1st. Contrary to M. Meynier's assertion, we have found that the rhodanide of ammonium (sulphocyanide of ammonium) is a violent poison; less so, it is true, than cyanide of potassium; but it is dangerous, nevertheless, to lead the public into error on this point; therefore, we repeat this substance is a violent poison.

2nd. The rhodanide of ammonium decomposes in the air; it acts as a fixing agent in the same manner as the rhodanide of potassium, which is less poisonous, much more stable, and is prepared much easier.

3rd. The rhodanide of potassium fixes the proofs in the same manner as cyanide of potassium; that is, it communicates a disagreeable yellow tone to the proof, especially if on albumenized paper. [Dr. Van Monckhoven's experience is at variance with our own, in this respect. We have not met with any yellowness in the whites.—Ed. P. N.]

4th. We can, however, avoid in great measure this yellow tone by adding to the rhodanide a small quantity of chloride of gold, which colours the solution red.

5th. The rhodanide of potassium communicates a yellow tone to the proofs which the gold toning seems to cause to disappear, but in reality again becomes apparent when the positive is left to dry.

6th. In fact I prefer, until a more complete examination, the hyposulphite to the new salt, which possesses no real advantage, for it contains sulphur like the hyposulphite, and there is no evidence that it cannot abandon a portion and sulphurize the proof. Besides, nothing proves that it completely dissolves the albuminate of silver, for the experiments made by us in this direction have proved very discordant.—*Bulletin Belge de la Photographie.*

ON DEVELOPING WITH PYROGALLIC ACID.

BY M. L'ABBE LABORDE.

In a note which I had the honour of presenting to the Photographic Society (of Paris), on the proportion of the iodides, and the value of each, in photography, I remarked that the nitrate and the acetate of alumina favoured the action of the gallic and pyrogallie acids, to the degree that the latter could rival the ordinary solution of pyrogallie acid. These salts, strictly speaking, do not increase the reducing power of pyrogallie acid, but they singularly hasten its action; it is precisely to this particular circumstance, and to the reasons which may give it importance, that I now propose to call attention.

All the salts of alumina do not enjoy this property in the same degree: thus, the formiate of alumina added to the solution of pyrogallie acid, is no sooner poured upon the negative, than the picture appears with all its details; the action of the nitrate and acetate of alumina is less prompt; the sulphate acts still more slowly. In alum, the employment of which, has been recently explained by M. Martin, it is not the sulphate of potassa that acts, but only the sulphate of alumina. Being induced, for certain reasons, to select nitrate of alumina, I employed the following formula.

Water	300 parts
Nitrate of alumina	1.50 "
Pyrogallie acid	1 part

The nitrate of alumina must be very pure, free from iron especially, and dissolved in water. This salt often contains some insoluble nitrate, and has such great tenuity, that part of it passes through the filter; the liquid is poured a second time upon the same filter, the pores of which, obstructed by the sub-nitrate, have become so fine, that the liquid passes through perfectly transparent. This solution keeps well, but the pyrogallie acid must not be added to it too long in advance of use. To always have a freshly prepared solution, divide a gramme of pyrogallie acid into ten parts, and put each portion into a piece of paper. When it is desired to

make a normal picture, for example, put into a test glass 30 grammes of the solution of nitrate of alumina and one portion of the gramme of pyrogallie acid; it is well to add a few drops of alcohol in order to cause the solution to spread rapidly over the collodion film, without any defect of continuity on the impressed plate. The alcohol may be omitted with small plates, which are easily covered without this auxiliary, and thus the action of certain alcohols which slightly fog the image is avoided. The quantity of nitrate of alumina indicated above is an average proportion, and may be varied. It is often objected to sulphate of iron that its action is too rapid and brusque to be managed; and many eminent photographers prefer a slow and progressive development. But in presence of the admirable results obtained by sulphate of iron, we must modify this view. For we may ask if the valued qualities of sulphate of iron are not due to its rapidity of action. In a slow and progressive development, the operator feels more mastery over the picture; but if the picture obeys only to exceed the aim, and destroy the equilibrium which should exist between the different tones of the picture, then there is only an apparent advantage in being able to regulate its coming. We know also that in photography, the things which do themselves are always more perfect than those which depend upon the skill of the operator.

The advantages which I think may be attributed to the rapid action of the developer are, that the negatives possess more detail, and rarely give those absolute blacks in the picture which never exist in nature. I readily believe, that upon leaving the camera, not only the iodide of silver, but the nitrate itself, is modified—not the nitrate that runs freely from its surface, but that in contact with, and adherent to the iodine, and which, under the developing agent, concurs more powerfully to the reduction than ordinary nitrate of silver. The question is—is this nitrate modified under the influence of light because it forms with the iodide of silver, which it tends to dissolve, a more sensitive compound; or, because it is in contact with organic substances, as alcohol and collodion, which it slightly penetrates? It is difficult to say: there it is, and, as we all know, great care is required when the developer is poured over the exposed plate; if the liquid is poured on carelessly, the reduction fails in the spot where the liquid is first poured, and not merely because we thus drive away the ordinary nitrate of silver, for if we restore it, we never succeed in re-establishing the equilibrium between this portion and the remainder of the picture. The almost sudden slackening in the appearance of the picture after the first reduction, which has brought it out almost entirely, clearly proves that there is one favouring circumstance, at least, and that we can replace it only very imperfectly by renewing the dose of pyrogallie acid and nitrate of silver. From this we may understand, that a developing agent, the slowness of whose action manifests the strongest tints first, will never show the weaker under so favourable an influence, and that there will be a defect in equilibrium between the first and the last; while a developer more prompt in its action, bringing everything out at the same time, will show the action of the light more faithfully.

When a picture is developed and washed in the space of a few seconds, the developer has scarcely time to penetrate to the surface of the glass, the imperfections of which are less evident, and there is one chance the more of obtaining a good negative. In fact, I have often remarked upon certain plates, spots which obstinately appear after a long development, while they are scarcely apparant when the nitrate of alumina, united with pyrogallie acid, had permitted the development and washing of the picture within the space of a few seconds. I do not speak of the impurities left on the surface of the plate, and which always produce spots, because the collodion becomes impregnated by them, but of the substances which adhere strongly to the glass, and seem, from the difficulty of removing them, to combine with it.

All the salts of silver which I have tried in conjunction

with pyrogallie acid allowed me to dispense with the addition of any other acid, excepting the pyrogallate of alumina, which may be employed alone, and demands the usual dose of acetic acid.

If the sulphate of iron was always successful, I should dispense with preparing another developing agent as prompt in its action; but it very often fails in cases where the pyrogallie acid and nitrate of alumina may give very good negatives. If, for example, we employ a collodion simply iodized with iodide of cadmium, sensitized in a neutral nitrate bath, the sulphate of iron will almost always blacken the exposed film, while pyrogallie acid united with nitrate of alumina will supply all the elements of success.—*Bulletin de la Société Française de la Photographie.*

AUTHENTICATED FORMULÆ.

CONTRIBUTED BY FIRST-CLASS PHOTOGRAPHERS.*

WE are enabled, by the courtesy of several gentlemen, who are recognized by the photographic world as amongst the very ablest exponents of the art, to publish the formulæ by which they habitually work. In most cases these formulæ are simple enough, and are just the same as are generally used by others; but their publication possesses this advantage: where it conveys nothing new, it gives confirmation to what is; for the most valuable confirmation of the worth of any process, is the publication of successful pictures. It, moreover, confers a dictum we have often urged, that success is due to the man rather than the method. An intelligent application of a process is essential to good photography; and a thoughtful application of art principles is essential to a good picture. Ruskin observes, that "patience and sand paper will not make a picture," although they may give a smooth surface; and the most perfect formula will not yield an artistic photograph, except it be in the hands of an artist.

PORTRAITURE.

MR. T. R. WILLIAMS'S FORMULÆ.—The prints are exquisitely delicate, perfect, and brilliant. Tone warm, neutral tint. Mr. Williams prefers a 30-grain nitrate bath to a stronger solution. A good commercial nitrate of silver, purified with carbonate of soda, if necessary. A trace of nitric acid, generally less than a drop in a pint of solution.

A commercial bromo-iodized collodion. Frequently a mixture of that of different makers, not unusually Mawson and Rouch.

Developing solution, in summer:—

Protosulphate of iron	15 grains
Acetic acid (glacial)	15 minims
Water	1 ounce
Alcohol	quantum suff.

In winter:—

Protosulphate of iron	30 grains
Acetic acid (glacial)	15 minims
Water	1 ounce
Alcohol	quantum suff.

Fix in a dipping bath containing saturated solution of hyposulphite of soda, and wash very thoroughly.

Intensify after the negative is dry, with bichloride of mercury and iodide of potassium, as used by the late Mr. Laev. Sometimes, before drying, but after fixing, with pyro and silver.

In printing, with albumenized paper prepared with 10 grains of chloride of barium, use a silver bath, strength from 30 grains to 50 grains per ounce. With most commercial papers containing an unknown proportion of chloride, use an 80-grain silver bath, with a trace of nitric acid, and float one minute.

Print in diffused light, not much deeper than required in finished print. Wash and tone in acetate of soda and gold

* We reprint the above from the YEAR-BOOK OF PHOTOGRAPHY and PHOTOGRAPHIC NEWS ALMANAC for 1863, as meeting many questions which frequently reach us.

bath, usual formula, but made always a week in advance of its use. Never use twice. Fix in abundance of hypo, one part in six of water. From eighty to one hundred card pictures fixed in about two quarts of hypo, which is never used more than one day. Wash for four hours in constant changes of water, drain a few minutes, and wash a few minutes without leaving off, then dry without further soaking.

MESSRS. SOUTHWELL BROTHERS' FORMULÆ.—The prints are, perhaps, the most brilliant published, and very round, and finely modelled. Tone, rich, warm, sepia and bishe tints.

The silver bath contains 40 grains to the ounce, slightly acid, with nitric acid.

Collodion, a good commercial bromo-iodized; frequently Mawson's.

Developing Solution—

Protosulphate of iron	4 drachms
Glacial acetic acid	4 "
Water	16 ounces
Alcohol	1 ounce

Intensify before fixing with—

Pyrogallie acid	80 grains
Acetic acid	200 minims
Water	16 ounces

and a few drops of a fresh silver solution.

In printing use a good commercial albumenized paper. Excite in a 90-grain bath. Tone, and fix in a bath of hypo and gold, using great care, and wash well.

MR. H. P. ROBINSON'S FORMULÆ.—The prints are rich, round, delicate and vigorous. Tone, deep purple, brown, and warm neutral tints. The only card portraits specifically rewarded with a medal at the International Exhibition, and at the Exhibition of the Scottish Photographic Society.

Nitrate bath—

Pure recrystallized nitrate of silver	12 drachms
Water	20 ounces
Acetic acid	10 minims.

Collodion, a good commercial bromo-iodized sample; frequently Ponting's or Rouch's, and sometimes mixed.

Developing solution—

Protosulphate of iron	200 grains
Acetic acid	1 ounce
Water	20 ounces
Alcohol	2 "

Intensify before fixing with—

Pyrogallie acid	40 grains
Acetic acid	2 ounces
Water	20 "

and in a little fresh silver solution.

Print on good commercial albumenized paper excited on a 60-grain bath. Tone in a gold and acetate of soda bath, usual formula, made always a week or two in advance.

MR. Mc NAB'S FORMULÆ.—The prints are distinguished by especial brilliancy, with exquisitely deep and transparent shadows. The tones are rich purple browns.

The silver bath is prepared in the usual way, from recrystallized nitrate of silver, 35 grains to the ounce of water. If, on using it for the first time, it shows a tendency to fog, it is slightly acidified with nitric acid.

The collodion, made after Hardwich's formulæ, frequently mixed with commercial bromo-iodized samples.

Developing solution, 15 grains of iron to the ounce of water, when the light is good; but in cold weather, and weak indifferent light, it is increased to 20 grains. When intensity is lacking, use—

Iron	4 drachms
Acetate of soda	1 drachm
Water	17 ounces
Pyroligneous acid	2 "
Alcohol	1 ounce

The plates are developed and well washed, and put aside

in a rack to dry, until we find it convenient to clean them. When they are dry, a line of varnish is put round the edges to prevent the film from being removed in the following operations of cleaning and intensifying. The plates are wetted again, and fixed with cyanid of potassium.

Intensify according to the character of the picture. If the negatives are nearly dense enough, and but slight intensifying is required, pyrogallic acid, $1\frac{1}{2}$ grains to the ounce of water, and one or two drops of silver from a 30-grain solution. When the negatives are feeble they are treated to a weak solution of iodine, which is floated upon the plates for a short time; they are afterwards copiously washed previous to applying the pyro and silver.—At other times, intensify by pouring on a saturated solution of bichloride of mercury, until the film is of a grey colour, after which it is washed, and a solution of iodide of potassium, of one grain to the ounce of water, is applied until a greenish yellow tint is produced.

In *printing* use *Rive* paper for soft negatives, and *Saxe* paper for hard ones. The sensitizing bath contains 90 grains of silver to the ounce; the paper is floated upon it from three to five minutes, according to temperature. Tone with Maxwell Lyte's formula.

MR. MAYLAND'S FORMULE.—The prints very delicate and full of half tone, and, at the same time, exceedingly vigorous and round. Tone, a rich, warm neutral tint.

The *silver bath* is 35 grains to the ounce, and is very slightly acid, with nitric acid. *Collodion*, a good commercial bromo-iodized sample.

Developing solution—

Protosulphate of iron (in summer)	15 grains
Acetic acid	20 minims
Water	1 ounce.

The solution is better for being a few days old. In winter the iron is increased to 30 grains.

Intensify before fixing with—

Pyrogallic acid	1 grain
Acetic acid	40 minims
Water	2 ounces

with a few drops of 15-grain solution of silver. Fix with hypo.

In *printing*, good commercial albumenized paper; an 80-grain silver bath; two minutes floating and rapid drying. Tone with the gold and acetate of soda bath. Fix with hypo, one part in five, never used twice.

MR. HAWKE'S FORMULE.—The prints are delicate, brilliant, and very bold. The tone, rich purple brown.

The *silver bath*.—40 grains to the ounce, slightly acid with acetic acid.

Commercial bromo-iodized *collodion*, frequently mixed.

Developing solution.—

Protosulphate of iron	2 drachms
Glacial acetic acid	1 drachm
Water	1 ounce
Alcohol	<i>quant. suff.</i>

Intensify before fixing with pyrogallic acid two grains, citric acid one grain in an ounce of water and a few drops of silver.

In *printing*, use Sandford's thin *Saxe* albumenized paper, a strong silver bath, and acetate of soda and gold toning bath.

MR. PARKINSON'S FORMULE.—The prints are very brilliant and bold and finely modelled. The tones a rich, warm, intense black, with very warm, flesh-like half tints.

The *silver bath* has 30 grains to the ounce, always treated, when new, with oxide of silver, and then slightly acidified with nitric acid.

Commercial bromo-iodized *collodion*, often a mixture of Thomas's and Ramsden's, and for rapidity Rouch's, or a mixture of Thomas's negative and Mawson's positive.

Developing solution, a 20-grain iron solution with 20 minims of acetic acid and alcohol *quant. suff.*

Print on albumenized *Rive* paper excited on an 80-grain silver bath slightly acid with acetic acid. Tone with gold and chloride of lime, Ommeganck's formula.

LANDSCAPE AND INSTANTANEOUS PHOTOGRAPHY.

MR. VERNON HEATH'S FORMULE.—The prints exquisitely delicate, brilliant, with rich and perfect warm tones.

A 36-grain *silver bath* nearly neutral, or very slightly acid with nitric acid.

Collodion.—Thomas's bromo-iodized magnesian collodion.

Developing solution—

Protosulphate of iron	8 grains
Glacial acetic acid	20 minims
Water	1 ounce
Alcohol	<i>quant. suff.</i>

Intensify with pyro and silver before fixing.

Print in albumenized paper salted with chloride of barium; excite in strong silver bath; tone with gold and acetate of soda bath.

MR. BLANCHARD'S FORMULE.—The instantaneous pictures by this formulae are well known as exceedingly well detailed and brilliant.

The *silver bath* contains 40 grains of pure recrystallized nitrate to the ounce, neutral or with a very slight trace of nitric acid.

The *Collodion* contains a large proportion of bromide, and is prepared expressly for instantaneous photography.

Developing solution—

Protosulphate of iron	30 to 50 grains
Glacial acetic acid	20 minims
Water	1 ounce
Alcohol	<i>quant. suff.</i>

Intensify by different processes according to quality of image.

MR. ENGLAND'S FORMULE.—The perfect detail and delicacy of these instantaneous pictures are well known.

The *silver bath* contains 40 grains of pure nitrate to the ounce, and is worked neutral.

The *Collodion* contains 3 grains of iodide of ammonium, and 3 grains of bromide of cadmium to the ounce, and is sometimes mixed with commercial samples.

The *Developing solution*—

Protosulphate of iron	48 grains
Glacial acetic acid from	12 to 20 minims
Water	1 ounce
Alcohol	<i>quant. suff.</i>

Intensify before fixing with a two-grain solution of pyro, citric acid, and a little silver.

Print on albumenized paper prepared with 4 grains of chloride of barium, and 4 grains of chloride of ammonium to the ounce. Excite on a 60-grain silver bath; print very deep; fix in saturated solution of hypo, then tone in a solution of hypo and gold, both fixing and toning baths always used fresh.

Proceedings of Societies.

LONDON PHOTOGRAPHIC SOCIETY.

The usual monthly meeting of this Society was held on the evening of Tuesday, the 5th instant. Mr. Glaisher, F.R.S., in the chair.

The minutes of a previous meeting having been read and confirmed, Mr. J. Parsons was elected a member of the Society.

Mr. Richards exhibited and explained the photographic apparatus of M. Bertsch, consisting of a small "automatic" camera for producing small pictures, a stereoscopic camera, and a mezzotint or enlarging camera, for producing amplified proofs from the small negatives. He remarked that the end of

photography for the greatest number of artists and amateurs was to enable them to bring home from their travels souvenirs or subjects for study. Hitherto great difficulties had prevented many from profiting by this beautiful discovery. For, besides the volume and weight of the instruments and baggage required for photographic operations, and the difficulty of focussing and correcting the chemical focus, artists and connoisseurs had objected to photography, or rather to the instruments in use, that those instruments produced landscapes without foregrounds and distances, therefore the perspective was inaccurate, and nothing indicated the real scale. The truth of this objection had been mathematically proved in many reports, and especially in the excellent work by MM. Barreswill and Davanne on Photography. Struck by these defects, M. Bertsch, whose name enjoyed a great celebrity in science, had sought the means of correcting them, and he had so completely succeeded that his invention would, he thought, work a revolution in the photographic art. The instruments of M. Bertsch being made after the most exact laws of optics, formed a new and complete system; their precision was mathematical, and they gave, without focussing or correcting the chemical focus, landscapes most remarkable, as well for the bold clearness of the foregrounds as for the natural effect of perspective. The automatic camera was constructed with the double aim of reducing the baggage of the photographic traveller into a very small space, and of sparing him the trouble and difficulty of focussing. It was so constructed that the pictures it produced were perfectly clear from the foreground to an indefinite distance, and would bear enlarging to the extent of a yard square without losing any of the details. The apparatus complete, permitting to operate in open air by the wet process, was composed of a small case like that of a landscape painter, containing all that is required for working in the field. It served as a laboratory, and enabled the plates to be prepared on the spot. It contained the chemicals, the plates, and all the other things necessary. Of a camera obscura, also contained in the case, which produced pictures of all the objects from eight to ten yards, up to an infinite distance. And of a light trivet or tripod. Stereoscopic views were obtained on placing first the camera against one of the lateral sides of the little shelf, and then for the second picture the camera was removed to the other edge, the breadth of the shelf being adjusted to this end. As some amateurs had found the views of the automatic camera rather small, M. Bertsch had a double automatic camera constructed, so as to make at once the two pictures. The magnifying apparatus was distinguished from others hitherto employed not only by its smaller volume and weight, but by the results. It was screwed to a window-shutter facing the south. Being thus disposed, the mirror by the means of a parallactic movement was set so as to introduce the solar light by reflection into the axis of the lens. After this the diaphragm was put to the point where the rays cross, when the picture appeared in great brightness on the screen. The screen was moved forward or backward, according to the size the picture required. The focussing was effected by means of a pinion. Then applying a sheet of sensitized paper or a prepared plate, the picture was obtained. A distance of two yards gave an image one yard square. On a collodion plate the effect was instantaneous. On paper prepared by M. Bertsch an exposure from 15 to 20 seconds was quite sufficient.

Mr. RICHARD illustrated the mode of manipulation, and also called attention to a variety of small negatives and enlargements 14 inches square.

A conversation then arose as to the price of the automatic camera and equipment, which it appeared was £8 10s., and of the enlarging camera £17.

Mr. RICHARDS, in answer to a question, stated that the lens was single lens of short focus. It required no focussing, as all objects from ten yards distant to infinity were sharp.

Some conversation on this subject, which seemed to excite surprise, followed.*

Mr. ENGLAND then read a paper on the recovery of silver and gold from waste solutions and other residues. He exhibited

* As the statement referred to seemed to excite surprise, it may be well to explain a simple optical fact, which does not seem to be sufficiently well understood by photographers. The fact that all objects beyond a given distance to infinity are rendered in focus, does not arise from any peculiarity of M. Bertsch's lens, but is true of all lenses. The shorter the focus of the lens, however, the shorter the distance at which all objects to infinity will be in sufficient focus; and thus M. Bertsch's lens, having a very short focus, defines all objects within a moderate range, and thence beyond, indefinitely, without focussing.—Ed.

some fine ingots of pure silver, and some containing a percentage of gold, and also some silver again manufactured into nitrate.

Some conversation followed, in which Mr. England stated he had melted as much as 64 ounces of silver at one operation.

Mr. SEBASTIAN DAVIS asked if he used a Black's furnace.

Mr. ENGLAND said, "No;" with his own, built as described in his paper. A chimney of about 25 feet gave sufficient draught. The small Griffin's furnace he exhibited was heated by gas, and a small assay could be effected by it in about twenty minutes.

Mr. DAVIS asked what fuel he used with his own furnace. He asked, because he had had some difficulty with an Aikin's blast furnace with double action bellows. After half an hour's operations he did not get a sufficiently high temperature. He therefore wished to know what fuel Mr. England used.

Mr. ENGLAND used coke broken into pieces, about the size of an egg. He thought the best furnace was one built with a few fire-bricks, as he had described. He found 60 ounces might be reduced by keeping the pot filled up as its contents became less in bulk. He did not find any blast required, only the ordinary draft secured by having a 25-foot chimney.

Mr. DAVIS asked if he had used cyanide of potassium to assist in ready melting.

Mr. ENGLAND had tried it and found no advantage. He found the use of nitre the best to aid in getting rid of sulphur, which was sometimes very difficult to remove entirely. If any traces of it remained, the whole mass of metal would have a grey leaden colour from its presence, and it was then very difficult to dissolve it in the acid. If the sulphur were all removed the metal would be perfectly white. It would then dissolve readily, and any gold present would be obtained as a black powder, and the chloride obtained from it was in all respects as good as when made from the pure metal.

Mr. BROOKES asked Mr. England if he had understood him to say that the ashes from black silvered papers were of a light drab colour and turned darker in the light.

Mr. ENGLAND said that the paper to which he referred was much of it not exposed; he had not especially noticed the colour of the ashes, where all the paper was previously blackened. The especial peculiarity to which he had referred was the fact, that, after burning the paper the silver evidently remained in the form of a chloride, and had not in the course of burning been reduced to the metallic form, notwithstanding the state of fine subdivision in which it was subjected to heat.

Mr. HART said he had had a furnace made similar to a pipe-maker's furnace, standing upon a circular iron frame, about 3 feet high. It was covered at the top and had an outlet at the back. With a 10-inch black lead crucible, he had a space of an inch or two all round. In 25 minutes he could get a white heat, and reduce 8 or 10 ounces of silver in three quarters of an hour. It cost about 25s. and was very portable.

Mr. ENGLAND said ordinary Blenheim pots were the best; black lead was acted upon and quickly destroyed.

After a vote of thanks to Mr. England,

THE CHAIRMAN called attention to two very fine life-sized portrait busts, by M. Claudet, of Dr. Diamond, the secretary of the Society, and of M. Laurier the secretary of the French Society, produced from the negative in which those gentlemen formed a group. They were enlarged by means of the solar camera and were entirely untouched. They were both sharp round, soft, well modelled and brilliant, that of Dr. Diamond being an especially fine likeness.

THE CHAIRMAN also announced that it was probable the members would be called upon to attend an extra meeting, of which due notice would be given in the various journals, in order to hear Mr. Smith's account of the sun pictures at South Kensington. If it were a fact that sun pictures were taken 50 or 60 years before the supposed discovery of the art, it was most interesting to learn the fullest particulars.

THE CHAIRMAN said it might possibly be interesting to the meeting to hear a few remarks on his photographic experiments in a recent balloon ascent. He prepared some paper with chloride of ammonium and excited it with a 50-grain solution of ammoniacal nitrate of silver, and produced a sensitive paper which he knew gave uniform results under uniform circumstances. One-half of a sheet was left at the Observatory at Greenwich, the other he took with him. He left instructions that a portion of the paper was to be exposed for one minute, the first out of every five minutes in succession; while he would give some one minute out of every five, as opportunity might permit. Whilst they were below the clouds the results were

nearly the same, but above the clouds there was no discoloration at all in one minute. With a guide before his eyes, as a test for pure white, he could detect no change whatever, although the direct rays of the sun were upon the paper. The dew-point was below zero at the time; whether it was the dry state of the atmosphere, or what, he could not at present determine. He now only spoke to facts. One piece of paper which was exposed for half an hour was not so dark as several of the pieces had become at Greenwich in single minutes. He hoped to try it again and should be glad to receive hints from any one before the next ascent. His chief attention on the last occasion had been directed to the remarkable results he had obtained with the spectroscope. He had commenced with a fixed slit which showed the lines, from B to G, with the light from the sky; but when he got above the clouds the light from the blue sky gave him no spectrum at all; when he got the direct light from the sun, however, the lines were vivid and innumerable. He wished to try the experiment again, and so verify his observations. He might remark, that notwithstanding the non-actinic character of the light, the blue end of the spectrum appeared considerably longer.

A conversation on the causes of the want of actinism followed.

Mr. ENGLAND suggested that the temperature might affect the question. Placing white glass over sensitive paper would, by increasing the heat, make it print quicker.

The CHAIRMAN thought the difference in temperature was not sufficient to make much difference. It was probably more due to the absence of moisture.

Mr. P. LE NEVE FOSTER said a similar condition might be induced by the chloride of calcium preservative box.

Mr. ALLEN suggested that much was yet to be learned as to how far atmospheric conditions affected actinism. All photographers were aware that sometimes an apparently bright light was very slow, whilst a light which looked dull was very energetic. He thought experiments in a vacuum would help to elucidate the question.

Mr. DAVIS suggested trying experiments with iodide of silver, on dry plates, to ascertain if the same action had occurred with the latent image when developed, as with the apparent image of chloride of silver.

The CHAIRMAN said if there were an unlimited number of balloon ascents he might have time for this. He believed atmospheric conditions affected the question of actinic influence largely. He found it necessary on dry days to regulate the moisture in the Observatory to secure regular results in his photo-magnetic and other registrations.

After some further conversation the proceedings terminated.

PHOTOGRAPHIC PIRACY OF ENGRAVINGS.

(*Court of Common Pleas. Sittings in Banco. Before Lord Chief Justice ERLE, and Justices WILLES, BYLES, and KEATING, Saturday, May 2.*)

GAMBART V. BULL.

THIS was an action for pirating Rosa Bonheur's celebrated print of the "Horse Fair" by photographing copies of it for sale. For doing this the plaintiff brought his action and recovered a verdict with £10 damages. A rule having been obtained to set aside that verdict on the ground that the Copyright Acts did not contemplate or apply to photographic copies.

Mr. Collier, Q.C., Mr. Prentice, and Mr. Brandt showed cause against that rule; Mr. Coleridge, Q.C., and Mr. Rew appeared in support of it.

The CHIEF JUSTICE, in giving judgment, said, in this action the question had been raised whether a photographic copy of an engraving was an infringement of the rights given to the engraver by the statutes of George II. and George III., and he was of opinion that it was. The statutes that protected the rights of engravers began with the statute of the 8th of George II., cap. 13, which in its preamble recited that print-sellers and other persons had, without the consent of inventors and designers, taken the liberty of copying, engraving, and publishing base copies of such works, designs, and prints, to the great prejudice and detriment of the inventors, designers, and proprietors. The preamble, however, did not conclude the enacting words, which prohibited the copying of any engraving that the author of the engraving had invented, and it appeared

to him that that statute in its enacting part went much beyond lowering the estimation and character of an engraver by publishing a spurious article in his name. Engravings were made for money reward. The object of this enactment was to give to the engraver a money value for the product of his mind embodied in the steel engraving, prints from which could be multiplied and sold. Then came the statute of the 7th George III., cap. 23, which gave the same protection to engravers, and persons were thereby prohibited to engrave, print, publish, or import for sale any copy of an original engraving. The 17th George III., cap. 57, was the statute on which this action was founded, which was an Act "for more effectually securing the property of prints to inventors and engravers by enabling them to sue for and recover penalties in certain cases." This Act recited the statute of the 8th of George II. and of the 7th of George III., and then went on to recite that whereas the said Acts had not effectually answered the purpose for which they were made, and it was necessary for the encouragement of artists, and for securing to them the property of and in their works, and for the advancement and improvement of the aforesaid arts, that such further provisions should be made as thereinafter mentioned, enacted that "if any engraver, etcher, print-seller, or other person shall within the time limited by the aforesaid Acts, or either of them, engrave, etch, or work, or cause or procure to be engraved, etched, or worked in *mezzo tinto*, or *chiaro oscuro*, or otherwise, or in any other manner copy, in the whole or in part, by varying, adding to, or diminishing from the main design, or shall print, reprint, or import for sale, or cause or procure to be printed, reprinted, or imported for sale, or shall publish, sell, or otherwise dispose of, or cause or procure to be published, sold, or otherwise disposed of, any copy or copies of any historical print or prints, or any print or prints of any portrait, conversation, landscape, or architecture, map, chart, or plan, or any other print or prints whatsoever which hath or have been or shall be engraved, etched, drawn, or designed in any part of Great Britain without the express consent of the proprietor or proprietors thereof first had and obtained," then the proprietor of such print may bring an action for damages against the persons so offending. It seemed to him that that statute contained extremely wide words. It prohibited any person from engraving or in any other manner copying. The question was whether a photographer taking a photographic copy of a print had in a manner copied that print. In common language he had made a photographic copy of that print. These prints were of value; they gave pleasure; and the statute said to the designer and inventor, "You shall have a monopoly of selling that object of attraction as your reward." If that was the principle laid down by the statute, a photographic copy might represent exactly the same idea, and so diminish the sale of the engraver's print and his reward. He saw no reason why these general words should not apply to any mode of copying known at the time when the statute passed, or why they should not apply to any of the modes of copying which the ingenuity of mankind and the progress of science have from time to time brought forward. He felt bound to say that whether a photograph was of the same size, or very much diminished in size from the print which it copied, the statute applied. One of these photographs represented a French horse-fair, and horses in the highest enjoyment of animal life brought out for the fair. Though represented in a diminutive form, they gave the same kind of pleasure to the purchaser that the original did, and the photographic copies would be an interference with the sale of the print by the owner, and within the mischief that the statute was intended to prevent. The plaintiff was, therefore, entitled to recover.

The other learned Judges concurred in this judgment.
Rule discharged.

Correspondence.

FOREIGN SCIENCE.

[FROM OUR SPECIAL CORRESPONDENT.]

Paris, May 6th, 1863.

M. F. Zucchi recommends the following method of preparing collodion, which yields a very uniform, colourless product, and dissolves very readily in the mixture of alcohol and ether.

Into an earthen vessel put 20 lbs. of ordinary sulphuric acid and 9 lbs. of nitrate of potassa reduced to a coarse powder. These two substances are stirred together with a wooden spatula. At the expiration of 10 minutes add to the mixture 1 lb. of cotton, previously reduced to tufts the size of the thumb. The cotton is allowed to remain until a sample washed, pressed, soaked in alcohol, then dried, dissolves completely in a mixture of 2 parts ether and 1 of alcohol. When the solution takes place readily, the cotton is removed from the mixture, and freely washed in water until the latter no longer reddens litmus. After separating the water, by pressing the cotton in a linen cloth, it is placed in alcohol, and left for four-and-twenty hours. The alcohol acquires a yellow colour, and the cotton becomes perfectly white. It suffices then to free it from the alcohol by pressure, and to dissolve it in a mixture of 2 parts of alcohol and 15 to 20 parts of doubly-rectified ether, to obtain a collodion of excellent quality.

M. Zuchs employs the best carded cotton. It always has a yellow tinge, but upon operating as above it becomes quite white.

Treating the cotton with soda is useless; the sulphuric acid and saltpetre of commerce are sufficiently pure for the preparation, and the quantities of nitrate necessary are, according to the author, less than those usually prescribed.

The time of immersing the cotton in the acid liquors is almost always indicated, but the temperature they ought to possess is frequently omitted.

In summer, 10 minutes suffices for its complete transformation into a soluble product; while in winter we must place the mixture in a *bain-marie* before introducing the cotton, in order to prevent the precipitation of the bisulphate of potassium, which thickens the bath. If hyponitric acid is given off, and this inconvenience cannot be obviated by plunging the cotton beneath the liquid, it suffices to add a fresh quantity of sulphuric acid to stop the production of the irritant fumes.

The transformation of the cotton is not so prompt but that there is time to make successive trials of the immersed cotton to ascertain its perfect solubility. The alcohol employed by the author was 90 degs. strength, and the specific gravity of the ether 0.730.

The subject of enlarging photographic portraits was discussed at a recent meeting of our Photographic Society. The president, M. Regnault, made the following remarks:—Whatever may be the degree of ardour and hope with which photographers view the ultimate and radical solution of this problem, they are unanimous as to its importance; for the question of enlarging, considered as a whole, and under the hypothesis of a definite success, involves and resolves the principal *desiderata* of the photographic art. We know that the inherent distortion of large pictures, obtained direct by means of lenses of large diameter, is what most seriously vitiates and disfigures the products of this art, and that this defect fatally tinges them all, more or less.

Upon this point science is, unhappily, affirmative; and in spite of all artifices, expedients, and formulæ, and of the ingenuity of opticians and mechanicians, it asserts that distortion, in large pictures, is an inadmissible original vice. On the other hand, it has already, as we believe, proved that the small pictures obtained with very small lenses of short focus secure a perfect proportionality of reproduction. It has, according to recent works, which appear to merit every confidence, ascertained and proved in a constant and exact manner the conditions of distance, amplification, and form, which it is necessary to combine, to arrive in some measure, at these results mechanically. This, then, is a prodigious stride to make in the matter of *enlarging*, the result of which depends, as we perceive, on the previous perfection of the *diminishing*. If, therefore, we can transform these little pictures in all their proportions in a quite satisfactory manner, photography will produce works of a value hitherto unknown, since they will combine the qualities due both to extreme rapidity of force and a total absence of distortion.

Now, in what regards the participation of optics with instruments generally, the optical enlarging of very small pictures by the negative or positive method seems to be in a state of most encouraging progress, if even this is not saying too little.

But a great difficulty has always obstinately opposed the efforts of operators, and is even inherent to the sensitive film that sustains the image. When we enlarge a small collodion picture, it happens that the intimate or superficial structure of the film is enlarged with the rest, and presents inequalities, streaks, and other impurities previously invisible, so that the enlarged image becomes corroded and coarse.

Albumen remains much more homogeneous and pure in aspect after enlarging. But, as every one knows, it possesses the defect of requiring much longer exposure, so that in employing it one of the two great advantages of the process in question is lost.

So that the qualities of albumen and collodion will be reciprocally reversed; with the one, long exposure and relative beauty of the image; with the other rapid exposure, but an imperfect image. We must, therefore, propose as an aim to inquirers, in this part of the question, either the appropriation of these two substances to the office of support of the enlarging, by means which are the *x* of the problem, or by the induction or discovery of a new substance which shall combine the qualities, hitherto isolated of the two first. Inventors will, besides, be quite free in their researches: they will be neither limited nor cheated by a narrow programme, that which will give the means of obtaining the most perfect images in enlarging will receive the prize offered, whatever those means may be; if, however, the maximum of success realized by it appears sufficient.

M. Bertsch remarked that experience had shown him, that albumen carefully prepared and free from dust, and spread uniformly on a glass plate, and, when the iodide of silver has not been dissolved by cyanide of potassium, but by hyposulphite of soda, presents no appearance of network, even when enlarged one hundred diameters. If we could but increase its rapidity, it would, doubtless, permit our reproducing of the natural size, a full length portrait of seven-tenths of an inch in height. In these conditions, there would be no appreciable trace of network or of distortion.

M. Ernest Lacan relates, in the *Moniteur de la Photographie*, an account of his visit, on the 13th ult., to M. Lewitsky, to experiment upon a box of dry collodion plates received from M. Liesegang. The hour was five in the afternoon. M. Lewitsky took a plate from the box, and placed it in the frame without even brushing the dust off. It was exposed 6 seconds, the lens being a Voightlander, 3 inches diameter. The negative was washed in water, and developed with sulphate of iron, made by the usual formula, and the picture appeared with all its details. A portion was, however, slightly fogged, the light having penetrated by a hole made in the box at the Custom-house. It was now a quarter past 5. Another plate was exposed 15 seconds, which was too long. The box had been sent by railway on the 15th of March; consequently, the plates had been prepared a month. Similar experiments, made previously by M. Lewitsky, gave identical results. It thus appears that, with these dry plates, we can operate in the same manner as with moist collodion, without prolonging the time of exposure, which is evidently a very important step in advance.

M. Mazac, who has studied dry collodion for a long time, states that he makes collodion plates retain their sensibility a long time by covering them with a solution which he calls *vegcto-animalisée*, and which differs from anything employed hitherto. He does not give the formula.

A new photographic journal has been established at Milan, entitled *La Camera Oscura*.

SPONTANEOUS DEVELOPMENT OF THE COLLODION IMAGE.

SIR,—I was yesterday engaged in making an enlarged

negative from a collodion transparency, and tried two plates with two and three minutes' exposure. The pictures were both deficient in half-tone, and I accordingly increased the length of time to six minutes for the next picture. I was surprised on taking the plates into the dark room, to find a faint impression of the image spontaneously developed; on pouring on the iron, it *immediately* thickened up with chalky lights, but did not fog in the shadows as I should have expected. I repeated the experiment with an exposure of twenty-five minutes, and obtained a similar result with a decided increase of intensity, as much indeed as is usually required for a collodion positive. I poured on a few drops of iron developer in three draughts of water, and slightly increased the intensity. On removing the iodide I found that the image was of a powerful orange colour by transmitted light and of a greenish tint by reflected light. I think it not improbable that with a longer exposure, and the sun shining through the transparency, a negative might be obtained without any development.

I mention the foregoing as I remember having read the report of a discussion on the same subject.—I am sir, yours very obediently,

JNO. TEMPLETON LUCAS.

3, St. John's Wood Road, Regent's Park, May 1st, 1863.

[An important element in forming an estimate of the cause of the phenomenon, is a knowledge of the process employed; if simply wet collodion, then with what the collodion is salted. A simply iodized collodion without organic matter present would not, we think, with any exposure give a visible image. Bromide of silver is, however, more like chloride of silver, and blackens visibly under the action of light.—Ed.]

PHOTOGRAPHY IN THE UNITED STATES.

DEAR SIR,—You have probably noticed that we in this country have gone crazy over the Harrison's globe lens. We brag of it, and our writers tell great things of it, say it will do anything up to—say 100°. I have examined much work done by many of these instruments, and have been disappointed. In purchasing one of these lenses, a person may be lucky enough to get one that comes up to promise, but in many instances they must be exchanged several times before a perfect one is found. The "six-inch focus" ones are advertised to cover a circle of light twelve inches in diameter. Generally this circle does not exceed eleven inches.* One man will boast that his six-inch lens almost covers an 8 by 10 plate, while another finds decided blurring in the corners of only a four-fourths plate when working the same priced and sized article. It is this uncertainty of working that will damage confidence in them: could it be avoided they would prove a great success. We have an eminent optician here who will shortly manufacture a lens having all the virtues of the "globe" at one-half the price. He is at present perfecting his patents, and very many operators are awaiting his instruments rather than pay the exorbitant prices of Harrison's.

Photographically speaking, there is no excitement here. The carte de visite fashion is changing. The old style of showing a full length figure stiffly braced against an impossible railing or column, or savagely holding fast of a chair back, is dropped, and the more artistic style of a simple vignette face is now in vogue.

Double printing has not yet been introduced among us, but from its more beautiful effects, will soon become fashionable; for, truly, the American taste, heretofore so neglected, is becoming much more refined. I enclose a card portrait by myself, double printed. My method is simply to print the face with an ordinary vignette block or glass, and then taking the paper out of the printing frame, and holding it

in the left hand, lay on it a piece of glass having an oval black paper pasted to the middle of it as a shield to the face. Expose to the sunshine a few seconds, keeping the shield glass constantly moving in a small circle over the face, holding it by the corner with the right hand. I omitted to say that the negative must be taken with a neutral background somewhat darker than the face. In this way the head seems to stand out in relief from an atmosphere of space behind, thus avoiding the disagreeable effect of a blank white paper.* Mr. Moran, of Philadelphia, has made some very fine moonlight pictures by double printing. He first prints the sky, making a full moon by laying a coin over the glass, and then prints from the negative. The effect of having a tree, branch, or chimney-top appear against the moon is very fine. His photographic etching of "The Haunted House," printed in this way, is exquisitely fine, and perhaps stands at the head of American Art Photography.

By the bye, these Philadelphians have a Photographical Society which effectually surpasses our ancient institution in New York. They make theirs a sociable club, have rooms open at all times,—have a Photographic Library, walls full of pictures, floor full of easy-chairs, and all that sort of thing. They certainly beat us, but an old adage says, "A new broom sweeps clean." Will it last?—Very respectfully yours,

F. F. THOMPSON.

PHOTOGRAPHY AND MURDER.

DEAR SIR,—On the 15th instant, after reading an account of the murder of the young woman, Emma Jackson, in Stt Giles's, I addressed a letter to Detective-officer James F. Thomson, informing him that "if the eyes of a murdered person be photographed within a certain time after death, upon the retina will be found depicted the last thing that appeared before them, and that in the present case the features of the murderer would most probably be found thereon." I exemplified my statement by the fact of my having, four years ago, taken a negative of the eye of a calf a few hours after death, and upon a microscopic examination of the same I found depicted thereon the lines of the pavement on the slaughter-house floor. This negative is unfortunately broken, and the pieces lost.

I enclose you Mr. Thomson's reply, together with his permission for me to make any use I please of it.

The subject is of too great importance and interest to be passed heedlessly by, because if the fact were known through the length and breadth of the land, it would, in my estimation, tend materially to decrease that most horrible of all crimes—*Murder*.—I am, dear sir, yours very truly,

WM. H. WARNER, *Photographer*.

Metropolitan Police Office, Scotland Yard, S. W.

Friday, 9 P.M., 17th April, 1863.

RE "MURDER IN ST. GILES'S."

SIR,—I hasten to acknowledge the receipt of your letter of the 15th inst., handed me about an hour since.

The secret you convey in your letter—photographing the eyes of a murdered person—is one of the greatest importance, but, unfortunately it is unavailing in this instance, for various reasons, three of which I will give you:—1st. Life had been extinct some 40 hours prior to my seeing the body of Emma Jackson. 2nd. The eyes were closed. 3rd. A post mortem examination has been made, and she has been buried—shell coffin—since Monday last.

In conversing with an eminent oculist some four years ago upon this subject, I learned that unless the eyes were photographed within 24 hours after death, no result would be obtained, the object transfixed thereon vanishing in the same manner as undeveloped negative photograph exposed to light. I did not, therefore, resort to this expedient.

* The six-inch focus refers, of course, to the focus from the back lens, and probably means eight or nine inches equivalent focus. We have a Dallmeyer's No. 1 triple, with an equivalent focus of a fraction under eight inches, which covers a circle of light twelve inches in diameter. It is a pity that the misleading system of speaking of the focus of compound lenses, as measured from the back glass, is not abandoned, both here and in the States.—Ed.

* The specimen received from Mr. Thompson is very effective.—Ed.
† This arrangement is something similar to that attempted by the Photographic Society of London, some years ago, but which was found too expensive and not sufficiently appreciated to be continued. It is certainly a desirable arrangement, and we shall be glad to learn that it is successful in the City of Brotherly Love.—Ed.

With my sincere thanks for your kind letter and information,
I am, sir, faithfully yours,
W. H. WARNER, Esq.
Literary Institute, Ross, Herefordshire.

JAMES S. THOMSON.
Sup. Detective.

*Metropolitan Police Office, Scotland Yard, S.W.
Tuesday, 21st April, 1863.*

SIR,—In reply to your note of yesterday, I can only say that you have my compliance to make any use you please of my previous letter to you.—I am sir, in haste, faithfully yours,

W. H. WARNER, Esq. *Officer of Detective Police.*
Literary Institute, Ross, Herefordshire.

The International Exhibition.

REPORT OF THE JURY ON PHOTOGRAPHY AND PHOTOGRAPHIC APPARATUS.

Continued from p. 167.

Most satisfactory illustrations of the advancement of the art are shown in the display of instantaneous photographs, stereoscopic and otherwise.

In the production of marine subjects—sea, shipping, clouds, and atmospheric effect, it seems as if little remained to be accomplished, as the pictures of G. W. Wilson, Blanchard, and of C. Breese (United Kingdom, 3049) exemplify. The exquisite transparent stereographs contributed by the latter gentleman possess photographic and artistic beauties quite unsurpassed; every drop of water in breaking waves or foaming cataracts is reproduced by an operation perfectly instantaneous and with a transparency beyond comparison. The sea-gull is arrested on the wing, the balloon depicted in its ascent, whilst foreground and distance, sea and cloud, are each at the same time perfectly rendered. The effects of sunset and moonlight are beautifully given; and to add wonder to beauty, images of objects photographed by the light of the moon alone are amongst his contributions. It may be interesting to state in connection with these pictures that, instantaneous as they manifestly are, no other contrivance but a cap held in the hand was used for covering and uncovering the Dallmeyer's lens, thus showing the rapidity of the motion of the human hand, and the simple way of overcoming what has been thought so difficult a matter.

The street scenes of Mr. England (United Kingdom, 3117), executed for the London Stereoscopic Company, are perfect and beautiful, especially those of his views in Paris.

As not inferior to the majority of the contributions of this kind must be mentioned the instantaneous pictures of Warnod of Havre (France, 1548). They are of a size larger than the majority of instantaneous productions, consisting of sea, cloud, and shipping, possessing a delicacy and vigour with perfect definition in the highest degree satisfactory.

Reproduction is another interesting and valuable branch of the art which has attained a very high state of perfection, some excellent illustrations of which are exhibited.

The magnificent copies of the cartoons of Raphael, produced respectively by a member of the Jury and Mr. Caldesi (United Kingdom, 3061), cannot well be overrated. Mr. Caldesi's copies of the Phidian marbles rank amongst the most valuable applications of the photographic art.

Mr. Downes's map (United Kingdom, 3068) and other reproductions of engraving are perfect. The enlargements of Mr. Warner (United Kingdom, 3176) are most excellent.

The obtaining of fixed natural colours by means of photography still remains, as was before remarked, to be accomplished; but the Jurors have pleasure in recording that some very striking results of experiments in this direction were forwarded for their inspection by a veteran in photographic research and discovery, M. Niepce de St. Victor. These, about a dozen in number, 3, by 2½ inches, consisted of reproductions of prints of figures with parti-coloured draperies. Each tint in the pictures exhibited, they were assured, was a faithful reproduction of the original. Amongst the colours were blues, yellows, reds, greens, &c., all very vivid. Some of the tints gradually faded and disappeared in the light whilst under examination, and a few remained permanent for some hours. The possibility of producing natural colour thus established is a fact most interesting and important, and too much praise cannot be awarded to the skillful research which has been to this extent crowned with success. The Jury record their obligations to their chairman, Baron Gros, to whose personal solicitation they were enabled to obtain a sight of these remarkable pictures.

We now approach, for very brief notice, a variety of contributions illustrating several very important applications of photography. First amongst these may be mentioned the photo-lithographic process of Mr. Osborne, the photo-zincographic process of Col. Sir H. James, the photographic process of Mr. Fox Talbot, the processes of Mr. Paul Pretsch for producing, by the combined aid of photography and electricity, plates for printing, either in intaglio or relief. In all these the impression is produced in printer's ink, and by the aid of the ordinary letter-press, lithographic, or copper-plate presses; all the facility for rapid reproduction of the prints, and all the permanency, or, indeed, as far as the impression is concerned, the indestructibility of ordinary prints or engravings are in the productions under notice secured. Mr. Osborne (Victoria, 385) exhibits specimens by his process of the official colonial maps and plans of Victoria. All these are for the purposes required faultless, and consist of reproductions of the original plans, &c., in the same size and on amplified and reduced scale, any proportion to the original being, of course, easily obtained and with perfect accuracy. For such purposes his process has attained its utmost limit of perfection. The productions of Col. Sir H. James (United Kingdom, 3101), of a similar character, and applied to similar purposes, are not less perfect. The specimens exhibited consist of copies of the Ordnance maps, Hozarth's engravings, a page of an early edition of Shakespeare, Prynne's Horace, &c., also specimens of the transfers of the zinc plates, &c., illustrating different stages of the process. In a process based upon the same principle, and styled by Col. James phototypography, the sheet of paper is made to serve the purpose of the plate of zinc or lithographic stone, and where a small number of impressions only is required answers every purpose, as the speci-

mens contributed show. The specimens of Mr. Paul Pretsch (United Kingdom, 3140), both of block printing and intaglio printing, are very interesting, and in many instances exceedingly fine. We may mention as especially worthy of notice a print of the Venus of Milo and the portrait of a child, engraved by this process, and printed by means of the copper-plate press. These plates have received a little aid from the burin of the engraver, and render exceedingly satisfactory pictorial effect. The specimens of Mr. Fox Talbot's (United Kingdom, 3167) photographic process are very interesting; but his method has not received that practical attention by which results of high pictorial excellence has been attained. Mr. Ramage, of Edinburgh (United Kingdom, 3143) contributes some of the most perfect specimens of litho-photography in the Exhibition, consisting of the reproduction of engravings. The process by which they are produced is not stated, but is understood to consist in a modification of the processes of other discoverers. MM. Poitevin (France, 1503), Leimercier (France, 1501), and some others in the French court, also exhibit fine specimens of photo-lithography.

Based upon a similar principle, but of less economic importance, are the various carbon processes. The specimens produced in this country have not yet attained a degree of excellence, which renders them of much practical value. The most perfect process of which any specimens are exhibited are those by the method of Mr. Joubert (United Kingdom, 3105), styled the prototype process. Some of these are very good, and the rate of production is stated to be very rapid, but the details of the method are not made public. In the French department, specimens of very high excellence are exhibited. Amongst the contributors here, first, is the honoured name of Poitevin, to whose research much of what has followed is due. MM. Fargier, Garnier, and Salmon, Charavet and Carmarsac, and others also exhibit carbon prints of much excellence, a detailed notice of which, however, would occupy too much space here. M. Leth, and some others in the Austrian department, also exhibit very fine carbon prints.

The exhibitors of photographs in enamel, or vitrifiable colour, are not numerous, but many of the specimens are very fine. Mr. Joubert exhibits in the British department a number of large pictures enamelled on plates of glass, some of which are in monochrome, and others in a variety of tints, and are produced in some instances from negatives direct from nature, and in others consist of reproductions of engravings. A very high degree of excellence is obtained in many of them, and it is probable that an extensive application of the process for decorative purposes will ere long be made. M. Lafon de Carmarsac (France, 1506) exhibits some very charming photographic enamels, the application of which is in a different direction to those of Mr. Joubert. M. Carmarsac's specimens chiefly consist of miniature portraits. It is impossible to overrate the delicacy and perfection of many of these examples.

The application of photography to textile materials is very interesting, although its objects have yet to be developed. Madame Lafon exhibits some charming specimens on white silk, in which the photography and the designs possess much merit. In the Italian department some similar specimens were added after the conclusion of the Jurors' labours.

The applications of photography to the progress of astronomical science are not so numerous in the present Exhibition as the interest and importance of the subject might have rendered desirable. Mr. Warren De La Rue (United Kingdom, 2893), exhibits a series of his valuable photographs, recording the various phases of the total eclipse of the sun of 1860, which were produced in Spain in conjunction with the expedition sent out expressly for observing and recording the various phenomena in connection with that event. Several important points which up to that period were of considerable uncertainty and debate, were effectually and indisputably established by the aid of these photographs, and which, without their evidence, must still have remained undecided. Mr. De La Rue also exhibits his photographs of spots on the sun and of the moon in various phases. Mr. Beckley (United Kingdom, 3009), also exhibits a series of photographs of much interest, showing the spots on the sun at various periods.

The application of photography to the production of the enlarged images of the microscope receives many valuable illustrations, the exhibitors of which can, however, only be briefly chronicled here. Mr. Reeves Traer (United Kingdom, 3171) and Mr. Olley (United Kingdom, 3132) exhibit prints on paper from large negatives of minute objects taken through the microscope. M. Lackerbauer (France, 1553) exhibits some exceedingly fine enlarged microscopic images as transparencies on glass. M. Roncalli (Italy, 1249) exhibits some fine enlarged images on paper. In addition to these some interesting specimens are shown in which the inverse result is produced. These consist of reduced copies of pictures for microscopic examination; the results, although partaking of the character of toys, may yet become of important application. Mr. Reeves (United Kingdom, 3144), Mr. Stovin (United Kingdom, 3163), and M. Dagron (France, 1543), exhibit interesting specimens in this class.

In reference to the productions of many of the colonies, the Jurors have not space to enter into detailed notice; they may mention, however, that in many instances in their awards of merit to colonial exhibitors they felt that recognition of the circumstances under which the contributions were produced was necessary, and that a less amount of excellence here was worthy of mention than would have sufficed to secure it where the facilities for good results were more accessible.

The Jurors, in terminating their report, cannot conclude without stating their conviction that, rapid and important as the progress of photography has been since the Exhibition of 1851, it affords promise of still wider development, and still more important results, both in the stations it already occupies and in others it is yet destined to fill. Much of the progress already attained has been due to the disinterested exertions and research of individuals, but they may add their conviction that still more may be attributed to the influence of the Photographic Society. This Society, founded under the august auspices of the late lamented Prince Consort, who to the perfol of his death continued its patron, and took the deepest interest in its welfare, and the minor associations of a similar character which have since sprung up, have, by concentrating and fostering the exertions of individuals, contributed in a degree not easily calculated to the present high position of the art. The exhibitions of the Photographic Society, held from year to year, have been at once the incentives to exertion and the landmarks of progress; during the past, and will, doubtless, continue to exercise a still more marked influence on the future; and the Jurors of the next International Exhibition will, probably, be called upon to chronicle results to which those now recorded bear but a small proportion in beauty, vastness, and importance.

HUGH WELCH DIAMOND, Reporter.

Talk in the Studio.

INSENSITIVE PATCHES ON RESINIZED PAPER.—Mr. Burgess, of Norwich, writing on the occurrence he had met with of insensitive mottled patches on resinized paper, says:—"It seems to me that the paper becomes *hardened* by keeping after being resinized, so much so, that when it has been kept a month or two, a 60-grain bath will no longer penetrate it sufficiently to combine with the chloride, except the little that happens to be in the surface. The paper does not repel the solution as though it were greasy, the surface being completely *wetted*, and yet when dry and exposed to the light, it is found that very little chloride of silver has been formed. I have not tried the addition of alcohol, having found an efficient remedy by increasing the strength of the bath to 80 grains per ounce. If the *hardening* of the paper does really take place, I think it a very valuable property, rendering a print on resinized paper much more permanent than one on albumenized or plain paper."

TINTING ALBUMENIZED PRINTS.—We have a hint to offer as to the method of applying the dye or tint to albumenized prints as described in our pages a few weeks ago. Instead of immersing the wet print, let it be dried first, and then float on the tinting solution the same as exciting on the silver bath. A cleaner, better effect is produced, possessing more delicacy. We have received from Messrs. Bailey and Son some of Mr. Sutton's photographic tints which may be applied as we have described. These possess some advantages in variety and colour over those before described, and will answer the purpose admirably.

CALCIO-CHLORIDE OF GOLD, &c.—We have recently been trying Mr. Sutton's calcio-chloride of gold as prepared by Messrs. Bailey and Son, of Wolverhampton. It answers capitally; toning rapidly to any tint without giving the slightest trouble. As it is sent out in solution only requiring diluting prior to use, it will especially answer the purpose of many amateurs who desire to decrease their preparatory labours as much as possible. The only hint we would give in opposition to the instructions on the bottle would be to dilute considerably more than is recommended. With the proportion of water recommended to be added, namely, from 3 to 5 times the bulk, the toning is almost too rapid.

INSTANTANEOUS PORTRAITURE FOR CHILDREN.—Mr. Inskip, of Scarborough, has sent us a pretty portrait of a laughing child, evidently taken instantaneously. He has also sent us details of his mode of working in such case. The collodion is made with four grains of soluble cotton, made as described in our ALMANAC dissolved in equal portions of ether and alcohol, the latter having a specific gravity of .820. It is salted with three grains of iodide of ammonium and three grains of bromide of cadmium. The silver bath contains 35 grains to the ounce, neutralized with a few drops of a saturated solution of carbonate of soda. If it should fog a little, glacial acetic acid is added until it works clear. The child is arranged on a table, brought out as much to the light as possible. All blinds are thrown back to get all the light possible without direct sunlight. A Barr's short focus lens is used without stops, and the exposure is as short a time as possibly can be given—not time to count one. The picture is developed with 25 grains of iron to the ounce, with 6 drachms of acetic acid, and 6 drachms of methylated spirit to 20 ounces. After developing the picture well out it is washed, fixed, rewashed, and dried. The picture generally is rather thin with the short exposure. The edges are varnished to keep on the film. After moistening the plate with water, a solution of iodide of potassium and iodine in water, about the colour of sherry, is applied, the plate is well washed again and re-developed with pyrogallic acid 2 grains, citric acid 1 grain to the ounce, with a few drops of a 20-grain solution of silver, until the required density is obtained. Mr. Inskip adds:—"I have no doubt but some will think it too tedious a process to use, but I find it to my advantage to take the extra trouble, and have no doubt others would do the same."

To Correspondents.

R. C. R. B., Jeenseewalway.—The use of a collodion containing a good body of pyroxylene will aid you in obtaining density, and the use of a cadmium iodizer, and about 14 grains or more of a bromide will aid in preventing the red solarization to which you refer. 2. Pinholes arising from printing ten or a dozen copies of a varnished negative can only arise from the use of an imperfect varnish. A good spirit varnish would protect the film better. 3. The prints being cold when finished arises from over-toning. If you used, as you say, a large amount of citric acid in clearing your

bath, you have probably weakened it considerably by the free precipitation of silver; it would, moreover, liberate nitric acid, and this would make the prints look cold and poor. 4. There are no special instructions required for copying engravings. Use a copying camera; stop your lens down as much as the light will permit, so as to secure definition; use a strong and acid nitrate bath; a collodion giving sufficient density; or bearing continued intensification without leaving the plate. If sufficient intensity is not easily obtained, proceed as follows: apply bichloride of mercury, wash, apply a one-grain solution of iodide of potassium, wash, and apply a strong solution of pyrogallic acid and silver. In copying oil-paintings more care is required in getting suitable lighting, and the use of a freely bromized collodion. 5. Pin-holes in tannin plates most probably arise from turbidity in some of the solutions. Transparencies of tannin plates are produced by exposing them under a negative for a few seconds, and developing in the ordinary manner.

G. H. C.—Acetate of soda may be used in combination with carbonate of lime; and the latter may be added in excess without doing harm. We cannot, with certainty, say how long the bath so prepared will keep. That must be ascertained by trial. If your toning bath bleaches too much, make it weaker or keep it longer before you use it, or place it in an open vessel for some time before use. A dark spot in the centre of the negative is not a common occurrence with a single lens. Send us an example.

L. L. H.—We have had similar complaints of the same lenses by which your specimen was taken. Those regarding which you inquire, cover well, and are very rapid, and in all respects well suited to your purpose.

R. C. H.—Your cards have some good qualities, and their faults lean to the best side, that is softness rather than hardness. You have a little excess of diffused or front light, which detracts from perfect modelling, and your lens does not cover sufficiently well. Dr. Diamond's address is Twickenham House, Twickenham.

XXX.—We have repeated until we are weary of doing so, that the use of bicarbonate of soda in the toning bath is undesirable, except in skilled hands. You use 30 grains of bicarbonate of soda to half a grain of gold, and are surprised that the solution does not keep! We fear you have paid but little attention to the numerous articles on toning which have appeared in our pages. Read the instructions on this subject in our ALMANAC, or use the gold and acetate bath.

A. BISSIER.—When you speak of "a camera for 30s.," do you mean a camera and lens? If so, you cannot get anything worth having at the price. If you mean a camera only, it is quite possible to have a useful article for that money. If you want the cheapest portrait camera and lens, you may find in various catalogues quarter-plate French lenses at about 25s. or 30s., and camera to match at 14s. or 16s. Such a camera and lens will answer for a beginner.

J. BERGESS.—It is very probable that your suggestion as to the hardening of the resin may be correct. An enlarging camera to enlarge a quarter-plate negative to 18 by 15, with a lens of 9½ inches equivalent focus, should have a total length of between 60 and 70 inches, say, to avoid fractions, 60 inches on one side of the lens and 12 inches on the other, that is, between a lens and the negative. We should use less front light, and avoid the use of white lace draperies in the card portraits.

G. F.—It is quite true that the use of tartaric acid in the developer was tried years ago. We tried it ourselves six or eight years ago. But it is frequently wise to try old suggestions in the light of additional experience. It was proposed before for use with pyrogallic acid, now with sulphate of iron. The saccharo-sulphate forms fine crystals, which keep well. The old ethereal collodion, containing five parts of ether to three of alcohol, is rarely used now. At one time seven parts of ether to one of alcohol was commonly used. Equal parts of each are now generally employed, and in some cases two parts of alcohol to one part of ether.

F. C.—Use blotting paper at the corners of your dark slides; this will prevent the stains of which you complain. 2. In the case to which you refer the use of a turbid iron developing solution would cause pin-holes in the film.

PANORAMIC PICTURES.—We received a few weeks ago a panoramic picture about 13½ inches by 5½ inches, consisting of two halves joined together without any note or advice concerning it. We shall be glad to hear from the sender.

FRED. CLIFF.—Any gold remaining in used-out toning baths may be thrown down in the form of a dark powder by adding protosulphate of iron to the solution. This powder, which is metallic gold, may be converted into chloride of gold by means of aqua regia in the usual manner. Any silver in your developing solutions will be precipitated in the form of a grey powder, by allowing the solution to stand.

J. STIRIA.—If you found the addition of acid to the bath partially removed the markings, probably the addition of more will entirely remove them. You may add nitric acid freely to a bath in which a bromo-iodized collodion is used without appreciably diminishing its sensitiveness.

A. B. C.—The object of adding acetate of soda to the silver bath is to form acetate of silver, which, under certain circumstances, is favourable to density. We do not use it ourselves, nor recommend it; although it has some good authorities in its favour. 2. Reducing the size of the stop will increase both the extent of the definition and the depth of focus. Removing the stop further from a single lens will decrease the field covered, but improve the definition; putting the stop closer to the lens will increase the field, but injure the quality of definition. We do not know of any advantage the aplanatic possesses over the ordinary simple combination. Several correspondents in our next.

Photographs Registered during the Past Week.

MESSRS. W. AND D. DOWNEY, 9, Eldon Square, Newcastle-on-Tyne,
Photograph of Lord Brougham.

MR. ROBERT SLINGSBY, Lincoln,

Three Photographs of Lincoln Horse, Sheep, and Pleasure Fair

MR. JOHN STUART, 120, Buchanan Street, Glasgow,

Four Photographs of the Rev. Mr. Cowan.

* * * The Publisher respectfully requests that all remittances above 3s. may be made by Post-Office Orders, payable to THOMAS PIPER, at the Chief Office, St. Martin's-le-Grand. Sums below 3s. may be remitted in postage stamps.

THE PHOTOGRAPHIC NEWS.

Vol. VII. No. 245. May, 15, 1863.

CONTENTS.

	PAGE
Recovery of Waste Silver.....	229
Formic Acid in the Developer. By H. G. Cooper, Jun.....	229
Enamelled Photographic Paper. By L. M. Liesh.....	230
Landscape and Instantaneous Photography. By W. H. Warner.....	230
Scientific Gossip.....	231
Critical Notices.....	232
On the Action of Photographic Varnishes upon the Collodion Film. By Dr. D. Van Monckhoven.....	233
Recovery of Gold and Silver from Waste Photographic Materials. By William England.....	234

	PAGE
A Short Lesson in Photography.—No. 13.....	235
Copyright in Engravings and Photographs.....	236
Photography in Tropical Climates.....	237
Fogging Nitrate Baths.....	238
Correspondence—Foreign Science, &c.....	238
Photographic Notes and Queries.....	239
Talk in the Studio.....	239
To Correspondents.....	240
Photographs Registered during the past Week.....	240

RECOVERY OF WASTE SILVER.

On another page will be found an interesting paper by Mr. England on recovery of silver from the various residues accumulating in photography. When it is remembered that little more than one and a half per cent. of the silver used in printing is actually to be found in the finished print, and that consequently upwards of £4 18s. 0d. out of every £5 spent in silver, is waste, unless some steps be taken to recover it, the question becomes one of serious import.

There will be of course a practical limit to the amount of silver possible to be recovered, and perhaps before that is reached, a limit to the amount it will be remunerative to recover, for it is quite possible in such operations for the cost of the effort to exceed the value of the result. But it is quite clear that with moderate effort a large proportion of the silver now wasted in too many establishments might be saved. Where the amount of work, especially of printing, is small, the trouble of recovering the silver as chloride and sulphide, and then of reducing it to a metallic state, seems somewhat formidable, and the result is scarcely considered worth the constant attention necessary. It is to be regretted that a system of collecting argentiferous waste, in which photographers might have confidence, is not established. Attempts have been made to establish such a system, we know; but, we believe, without much success. In other trades in which the precious metals are used the sweepings of the rooms, the dusters employed, &c., are regularly collected, and command a specific price remunerative to those who save and those who collect, and it is much to be regretted that a similar system does not obtain for photographers.

Refiners are prepared, we are aware, to purchase the various residues containing silver, or to reduce it, making a specific charge for the operation. But there is a want of confidence existing which makes photographers indifferent about availing themselves of the aid of the refiner. One photographer, we know, who took a large quantity of chloride of silver for reduction, was coolly informed, on calling again for the reduced metal, that the crucible had unfortunately cracked, and his silver was lost. It was not until after he had threatened legal proceedings he obtained any satisfaction; and, finally, he received a small ingot of metal, not a third of the legitimate yield of the chloride he had taken.

Mr. England informed us that a short time ago, after burning an accumulation of sensitive papers, he carefully weighed out three parcels of the ashes, each weighing two pounds, having well stirred and mixed the ashes first, to avoid any possible difference in their character. One parcel of two pounds he sent to one refiner for reduction; a second parcel was sent to another refiner, and the third he reduced himself. The result was—eight ounces of metallic silver from the first refiner; nine ounces from the second; and ten ounces and a half from the parcel he reduced himself. Thus, if the silver were worth only five shillings an ounce, he was mulct, in one instance, of twelve shillings and six-

pence; and, in another, of seven shillings and sixpence, in addition to the legitimate charge for reduction. We do not wish to imply that dishonesty is an invariable, or even a common characteristic of refiners, we should be sorry to entertain such a notion; but the fact is, that a few such cases destroy confidence, either in the men employed, or the method adopted.

Where it can be done, however, it is a very simple operation for the photographer to reduce his own residues. Where gas is available, and a moderate amount only of the metal has to be reduced, the small Griffin's furnace, heated by gas, Mr. England informs us, answers admirably. There are similar small furnaces, costing but a few shillings, made for burning coke. We have seen a small stove, in which coke was burnt, used successfully for the reduction; and it is possible, although difficult, to obtain sufficient heat in a kitchen fire. The London pots, recommended by Mr. England, are cheap and excellent, and the flux employed is also cheap.

In Mr. England's establishment, which we recently visited, the recovery of the waste silver is provided for in all the arrangements. In the sensitizing room the excited sheets are suspended on pins along two sides of the room, and beneath, to catch the droppings, are curved glasses placed at an incline so as to flow to a common point where a jar is placed. These curved glasses are each about two feet long, and are formed of parts of a cylinder of fourteen inches diameter which is cut into three sections. A cocoa-nut matting covers the floor, which, when worn out, will be burnt, and yield probably more than its original cost, in argentiferous ashes. Pieces of waste blotting-paper or rag are at hand to wipe up small portions of spilled silver solutions. The kaolin is made to give up its silver and is used over and over again. The silver in washing waters is precipitated as chloride, and in old hypo baths as sulphide. All clippings of sensitive paper and waste prints are burnt, and even the ashes of waste fixed prints are made to yield something. We do not know whether Mr. England has made any exact calculation of the saving effected; but we believe it is possible to recover from sixty to seventy per cent. of the silver used. This, even in small establishments, is, we think, worth saving.

FORMIC ACID IN THE DEVELOPER.

BY H. G. COOPER, JUN.

I HAVE lately been making many experiments with formic acid in the developer; and as the subject of its use is now attracting considerable attention, the results which I have obtained may not be uninteresting to your readers.

I took a nitrate of silver bath of the strength of 30 grains of pure fused nitrate to the ounce, and having made it perfectly neutral, added one drop of strong nitric acid to 20 ounces of it.

The collodions I employed in my experiments were all, with one exception, bromo-iodized.

As I am more partial to the use of iron as a developer than to pyrogallie acid, I determined to use the former for my experiments. I made a solution of pure sulphate of iron, 20 grains to the ounce, and added thereto varying quantities of acetic and formic acids. (The former glacial and the latter of the pharmacopoeal strength.) The proportions that I found to answer best were 10 minims of acetic and 15 minims of formic acid to the ounce of developer.

The results showed that with the above quantities the exposure was reduced to one-third (from fifteen to five seconds, for instance). The negatives developed exceedingly clean, without the least trace of any deposit on the shadows; but were all very much wanting in intensity, the image being thin and grey. I could only intensify it in the following manner: after fixing, wash well. If the collodion be at all likely to slip, the plate should be dried, the edges varnished, and it should then be soaked for some minutes in warm water. Have ready a filtered 2-grain solution of bi-chloride of mercury. Cover the negative with a good quantity of it, or, better still, immerse the plate in a dish full of the solution. Carefully watch it, and as soon as the dark tint which it at first assumes begins to turn lighter, rapidly wash it.

Now immerse it in a very weak solution of iodine in iodide of potassium or of ammonium, about 1 grain in 5 ounces of water. Should stains occur under the after treatment these two solutions have most likely been too strong. The remedy is simple,—use them weaker. Do not let the plate remain long in the iodide solution; no visible change will take place. After again washing it may be exposed for an instant to diffused daylight. All the operations must be performed in the dark room, as the result is then much more under control.

The negative is now to be re-developed with pyro and silver in the usual way. The image will then be found to be of a deep orange tint, and very delicate; the particles of silver composing it appearing to be very fine. If citric acid, in place of acetic, be added freely to the pyro solution, the image will be of a splendid purple, but, of course, is not so non-actinic as the orange tint.

I have not yet tried formic acid with the double sulphate of iron and ammonia, but recommend it to the attention of those whose object is to secure instantaneous results.

5, Aberdeen Park.

ENAMELLED PHOTOGRAPHIC PAPER.

BY L. M. LIESH.

As enamelled paper is now attracting attention, it may be of service to those interested in the matter to know that the same paper may be had in London, equal, if not superior, to any I have seen by the German makers. Some four years ago I experimented largely upon various enamelled papers, with the view of applying them to photographic printing—a short description of my experience in this direction may be interesting and useful to your readers, who may wish to experiment in a similar direction.

My object in making these experiments was two-fold, viz.: to get rid of the grain of the paper, and of the brown tone usual in albumenized prints.

After trying various enamels I found that the oxide of zinc was the only one answering the purpose. I applied to Messrs. De la Rue and Co., Bunhill Row, London, to prepare a quantity of paper and cards enamelled with the pure oxide of zinc. The greater portion of this paper was prepared with two coats of zinc white, some had three coats; and some only one coat; the cards had three coats, a portion of the paper had ten grains of chloride of sodium to the ounce of enamel. This I used to float on a new bath; after a sheet or so had been floated, the plain unsalted gave the best results. The paper was floated one minute on a 60-grain nitrate bath, and was dried and exposed under the negative in the usual

way. It printed in about half the time of albumenized paper, of a blue-black tone, which did not alter in the toning and fixing bath of hypo and gold I then used.

The details of the negative were rendered in the most exquisite manner, and when removed from the fixing bath nothing could be more beautiful. The drawbacks of the paper were that the prints were apt to become injured in the subsequent washing, and even after they were mounted they were easily scratched. I tried coating the enamelled paper with albumen, but the tone was not so good. As a whole I obtained the best results with the enamelled cards; those had three coats of enamel, which gave a beautiful surface. These cards were floated on the silver bath in the usual manner, and printed upon, with a mask of thin black paper put round the outside of the negative to confine the image within proper bounds and leave the necessary white margin round the card. This saved the trouble of mounting, and obviated any fear of cracking, as the cards remained quite flat, and the finished card presented a neater appearance than if the picture had been mounted on it.

I may here remark that the paper prepared for me by De la Rue and Co. was not liable to crack. It was beautifully finished, and if my memory serves me right, the price of the two-coat enamel was about £2 10s. or £3 per ream, deny. They would not make me a smaller quantity to order; but, I dare say, now it may be had in smaller quantities.

I had also some prepared by another London house, with certain modifications, such as introducing salt, &c., &c., but I did not obtain any advantage; the enamelling was not quite so well done as that by De la Rue.

The above experiments may induce some of your readers who may have more time, to devote their attention to the subject; and if it does no other good, it will tend to remove the monopoly or secrecy that at present exists respecting the enamel paper.

Grange Road, Darlington.

LANDSCAPE AND INSTANTANEOUS PHOTOGRAPHY.

BY W. H. WARNER.

It may prove interesting to some of your readers to know of a formula which at all times will give satisfactory results whether employed as an instantaneous process or otherwise. It is one that I have used for every kind of work during the last eighteen months; it is certain, sure, and safe; it keeps well, and, above all, it is economical. To many of the veterans in photography it is probably well known already, but it is for the benefit of those gentlemen who have only occasional opportunities of practising our beautiful art, but who, nevertheless, appreciate a good negative, and are all the more pleased when they get one, I address myself.

Collodion.

Ponting's plain iodized 5 oz.
Perry's (new) bromo-iodized 10 oz.

mixed, it will keep any length of time, and works equally well at seven years old as it does at one month.

Bath.

Any good commercial sample of nitrate of silver 40 grains to the oz. made according to Lake Price's formula.

Developer.

Proto-sulphate of iron 30 grs.
Water 1 oz.
Glacial acetic acid, crystallizable at 50° 30 mins.
Nitric acid 1 min. to every 4 oz. of solution.
Alcohol quantum suff.

When the subject is well out, wash thoroughly. The nitric acid makes the film close and tough; it never reticulates in the hottest weather.

Fixing Solution.

Cyanide	10 grs.
Water	1 oz.
Nitrate silver	1 gr.
Wash thoroughly.	If not sufficiently dense, use—			
Iodine resublimed	$\frac{3}{4}$ gr.
Iodide potassium	1 "
Citric acid	1 "
Water	1 oz.

Be sure and not make up this solution with alcohol, as it causes stains on the plate.

My friend, Mr. Blanchard, in a late article, states that he has found that by the use of the iodine the negatives become hard. They do so *without the citric acid*, but I have printed fully 2,000 prints from one negative, intensified with my formula, and the last was equally as good in tone as the first. The addition of the nitric acid is also important, the plate works foggy and dirty without it—with it, clean and brilliant—the difference would be found at once. It also enables the iron solution to be kept for a long time without deteriorating.

Wash well and use

Pyro...	1 $\frac{1}{2}$ grs. (hot weather)
	2 to 3	"	(cold weather)
Citric acid	1 $\frac{1}{2}$ "
Water	1 oz.

Add 2 drops of a 20-grain solution of silver, *not* from the bath. Keep this moving on the plate until the solution becomes of a pale sherry colour, or rather, to the inexperienced operator, until the points of light appear sparkling and brilliant. Then *well wash*.

It must be apparent to every one that citric acid in this formula is brought prominently forward; for many years it has been my constant habit of using it. I found when using the collodions of Bolton and Co., Thomas, and Perry (Sheffield), that it gave me brilliant and beautiful negatives when others who used acetic acid failed. Mr. Keene, of Leamington, recommends acetic and citric acids mixed in the pyro solution; this gives very excellent results, but it occasions a little extra washing; it however rather tends to keep the positive soft and harmonious.

In conclusion, should any of your readers be tempted, in the course of the summer, to visit Ross and the lovely scenery of the Wye, I shall be happy to see them and help them out of any difficulties they may get into, photographic of course.

Scientific Gossip.

SPECTRUM analysis, after having passed through the preliminary stages of wonder and implicit credence, has now arrived at that point at which people begin to throw doubts upon the absolute accuracy of its deductions. It has been lately discovered that the spectrum of an element is not always identical in its different compounds; lines which are absent in one compound being rendered apparent by the presence of another body, and strong definite lines, hitherto considered to be characteristic of an element, being altogether effaced when some other body is present. M. Mitscherlich has remarked that the spectrum given by chloride of barium in presence of an excess of hydrochloric acid, is quite different to the spectrum of barium itself. At first he was inclined to attribute this fact to the presence of another metal, and in order to satisfy himself on this point he examined it synthetically. The arrangements adopted were very simple; the solutions to be examined were placed in a glass tube, closed at the upper end, and having the other drawn to a point and bent nearly to a right angle. The liquid flowed slowly through a bundle of fine platinum wires lodged in the point, and allowing at the same time the re-entry of air into the tube. He usually added a salt of ammonia to the solutions to facilitate the volatilisation of

the dissolved salt. In studying the chloride of barium spectrum he filled one of these tubes with a solution of acetate of baryta, with the addition of acetate of ammonia, and he filled another tube with concentrated hydrochloric acid. Upon placing the extremity of the first tube in a flame he found it produced rays characteristic of barium. When this was removed, and the tube containing hydrochloric acid was placed in the flame, no lines whatever were produced; but on placing the bundles of platinum wires at the extremity of these two tubes simultaneously in the flame, he saw the spectrum which he had previously obtained with chloride of barium. M. Mitscherlich has noticed analogous facts with the chlorides of calcium and strontium: but upon experimenting with iodides, fluorides, and sulphides of the alkaline earths, similar results were not obtained, the spectra observed being those characteristics of the metals themselves. Copper gave curious results in its different combinations; the chlorides and iodides of copper give distinct spectra according to the combination. Sulphide of copper gives no spectrum; this fact might be attributed to the fixity of this combination, but the following experiment puts this explanation out of the question:—A solution of chloride of potassium, in presence of sal-ammoniac and excess of hydrochloric acid gives no spectrum in spite of the volatility of chloride of potassium, whilst this salt by itself, and much more diluted, gives the characteristic ray of potassium. This may be accounted for by the reduction of the salt being in the latter instance effected by the flame, which in the first instance could not be the case.

It is important to note the fact that certain rays in the spectrum of a metal may be effaced by the presence of a different substance in the flame: thus, the blue ray of chloride of strontium disappears in presence of the spectrum produced by chloride of copper with addition of sal-ammoniac.

Wishing to go a step further M. Mitscherlich sought to discover whether the rays usually considered characteristic of metals were produced by the metal itself as by its oxide. For this purpose it was necessary to avoid the reducing action of the flame. With this object he heated the combination to redness in a porcelain tube closed at each end with glass; and commenced by receiving on the spectro-scope the light emanating from the inside of the tube containing the combination partially reduced to vapour. This light being very feeble he placed a bright flame at the other extremity of the heated tube, allowing thus the rays furnished by the substance to be observable owing to their being reversed. M. Mitscherlich's experiments were chiefly with soda, sodium, chloride of sodium and carbonate of soda; sodium alone gave a spectrum under these circumstances. With all deference to the opinion of M. Mitscherlich, who is well known as an accurate and acute observer, we do not agree with the conclusions he draws from these experiments. He says that the result of these researches is that to the free metal alone are due its characteristic rays, and that if they are seen with its combinations, reduction takes place by the carbon and hydrogen of the flame. Very possibly this may be the case, indeed some recent researches about which we shall have more to say shortly, seem to prove that it is so, but we cannot admit that M. Mitscherlich's experiments prove anything except that the heat to which he submitted his porcelain tube was not sufficient to volatilize the contained soda salts. Sodium was the only substance which gave a spectrum under these circumstances, because it was the only body which could be volatilized at the temperature employed. To render the experiment worth anything the heat should have been raised sufficiently to render the other soda salts thoroughly gaseous, and then if their vapours, seen through the length of the tube, were unable to plough out the black line D from the continuous spectrum of the luminous flame, it might be regarded as evidence of what is attempted to be proved; but as the experiment at present stands it merely

shows that insufficient heat was employed. Granting, however, that further experiments would confirm M. Mitscherlich's opinion that the spectral rays belong to the metal in its pure and simple state, another deduction springs from the fact. That is that the solar atmosphere does not contain sufficient oxygen to oxidise all the sodium contained in it, and that all the metals having less affinity for oxygen than sodium are free; it may, moreover, be admitted that if in the solar atmosphere there exist metals combined with electro-negative elements in spite of the presence of free sodium their affinities are inverted at the high temperature of this atmosphere. Moreover, if the rays of certain metals are not observed it is impossible to be quite certain of their absence; for they may exist in a state of combination like chloride of potassium, which in the presence of some other bodies, as shown above, gives no spectrum.

A most ingenious barometer, for measuring small atmospheric disturbances, has recently been devised by Dr. Joule. It consists of a large glass carboy connected by a glass tube with a miniature gasometer, formed by inserting a small platinum crucible over a small vessel of water. The crucible is attached to the short end of a finely suspended lever, multiplying its motion six times. When the apparatus was raised two feet the index moved through one inch; hence he was able in serene weather to observe the effect corresponding to the elevation of less than one inch. The barometer is placed in a building, the slated roof of which affords, without perceptible draught, free communication with the external atmosphere. In this situation it was found that the slightest wind caused the index to oscillate, a gale occasioning oscillations of two inches, an increase of pressure being generally observed when the gusts took place. This barometer is undoubtedly very sensitive, and is highly spoken of amongst scientific circles in Manchester. It will however, of course, only show relative pressure, not absolute, as the indications would vary as much, or even more, by an increase or diminution of temperature. It would not be difficult we think to compensate it for temperature, and thus to render such a barometer an accurate measure of the height of the atmosphere as well as of its passing waves.

Critical Notices.

PRACTICAL ADVICE TO AMATEUR PHOTOGRAPHERS; or, the Direct Negative Process, v. Strengthening Positives. By HENRY MATHESON, eight years Principal Operator in the Photographic Department, Crystal Palace, Sydenham. London: JAMES HOW, Successor to G. Knight and Sons.

The author of the little work before us is a professional photographer of many years' standing, his experience, as he informs us, extending "from the old daguerreotyping times to the present of *cartes de visite*." It is almost impossible for an experienced practical man to write upon his art without saying something interesting and useful, and Mr. Matheson says much in his book which will well repay perusal.

The title of the book scarcely entirely conveys its character, for, whilst it contains much advice for amateurs, it is practically a manual for beginners, commencing with instructions for obtaining collodion positives and proceeding onwards to the production of prints on paper. Incidentally, in the course of his instructions, the author introduces what appears to be the great aim of the work, an argument in favour of simply iodized collodion, and a method of using iron development so as to secure negatives at one operation, as superior to the use of bromo-iodized collodion, and the necessity of using intensifying processes which he conceives it involves.

The author's predilections are very strongly in favour of what he terms the direct negative process, in which bromo-iodized collodions are, he states, "a delusion and a snare."

Mr. Sutton, who, as our readers know, has been the strong champion of simply iodized collodion against bromo-iodized collodion, has always insisted as one of the points of its excellence that it required the use of pure chemicals, simple and unsophisticated, the nitrate bath especially consisting only of pure nitrate of silver and water, without doctoring of any kind. Mr. Matheson insists on the addition of acetate of soda in the bath as a condition of success. As this is a point to which he attaches considerable importance, we will quote his remarks upon the subject:—

BEST CHEMICAL CONDITION OF BATH.—We have found that for a negative bath to give a film sufficiently sensitive, yet at the same time to develop dense enough for printing at once, and without re-developing or strengthening, or whatever it may be termed, a small quantity of *alkali*—masked, however, by a slight excess of some organic acid—is indispensable. To prove this position, let us examine the results we get from the formulae for bath and developing solutions which most beginners in photography are taught to use. Let us take the favourite one, which seems to be, pure nitrate of silver and distilled water, with a little iodide of some kind added to it (to prevent the silver entering away the iodide from the film of collodion), and perhaps a little alcohol or ether, or, may be, an infinitesimal dose of acetic or nitric acid. Practically, what is the result? Why, on developing the picture taken with an iodized collodion (which, we repeat, is best for negatives), and a neutral, or simple silver and water bath, it will be found that the picture appears struggling to get through a cloud of all sorts of photographic difficulties, in the shape of fog, veils, haze, streaks, comets, &c., &c., and the picture appears under-exposed. The remedy for this, say some, is a little acid—well, let us try—say, nitric. We try another glass, and what do we get? If sufficient is added to clear away the previous difficulties, we get another; for if developed with pyrogallic acid, the picture is certainly free from the previous defects, but the picture vanishes with them, and we only get the extreme high lights, and those so faint as to be totally useless for printing. With the iron developer the matter is very little better, besides the greater length of exposure necessary in the camera.

Suppose we had tried a little acetic acid instead, we should find the bath deteriorated in sensitiveness, without getting rid of our enemies.

Let us now try the system advised by the writer, starting with a neutral, or plain silver and water bath.

To a fifteen-ounce bath, of the strength of thirty-five grains to the ounce, let us add one or two grains of an alkali dissolved in a little distilled water; after well shaking this with the bath for a minute or two, the bath should be well filtered. After preparing a glass, and giving it the right exposure in the camera, what do we now find on developing? Positively nothing at all apparently. The film blackens instantaneously under the developer, and there is no picture to be seen, but we do see the character of the deposit is totally changed; instead of the previous greyish-laden line of the surface, we have, after the picture has been fixed and washed, a deposit of a brownish orange colour, and when held up to the light and looked through, the film appears of a brownish yellow, inclining in some places to a purple. The bath now evidently requires a little acid of some kind to prevent the spontaneous blackening of the film; but as the alkali was added to the bath to remove all traces of free nitric acid, it is evident that nitric acid cannot be used, or any other which would liberate it. We have tried various acids, but find none equal to acetic, which, for reasons too numerous to be mentioned here, we recommend as being the best. Acetic must be added very sparingly to the bath, just barely sufficient to mask the alkali and to develop clearly. Two or three drops are more than sufficient to neutralize the small portion of oxide of silver formed from the alkali.

As the strength of acetic acid is very subject to variation in different samples, and as it is not always possible, or convenient, to get pure caustic potash, soda, or other alkalies, it will be found much more certain if we take an acetate of any alkali, say acetate of soda (as the most conveniently obtained), because here acid and alkali are combined in equivalent proportions. To a fifteen-ounce bath add two or three grains of this salt, dissolved in half an ounce of distilled water; this will combine with the nitrate of silver when added to the bath, forming acetate of silver, which readily dissolves therein to the extent of nearly twenty grains to a pint. For this reason more than the two or three grains recommended may be added without injury, only that the proportion of acid which is to be added in addition will have to be increased in the same ratio, and will be found less manageable.

Supposing, then, we have added to a fifteen-ounce bath two grains of acetate of soda, we shall find, on developing a picture, the same spontaneous blackening of the film, provided there was no free nitric acid in the crystals of silver of which the bath was composed, as it very often happens there is a trace. Should there have been any free nitric acid in the crystals, it will perhaps be found not necessary to add any more acid, as the nitric acid may have liberated sufficient acetic acid from the acetate of silver by forming nitrate of the oxide of silver, and setting acetic acid free. Should, however, this not be the case, make a solution of a drop of pure nitric acid in an ounce of distilled water; add a drachm or two to the bath, occasionally trying a picture, until it develops satisfactorily.

It may be thought a paradox to add nitric acid, when we are trying to secure ourselves against the presence of this very acid; but it will be found that, although we could not use it to neutralize oxide of silver formed by the addition of alkali to the bath (as it would have been only bringing it back to its previous condition of a neutral nitrate), yet, in the case of the presence of an acetate, the effect is quite altered, as was shown by the description of the action of free nitric acid sometimes found in the bath, due to its being introduced in the crystals of some samples of silver.

No matter, however, how or by what method we introduce the acetate—whether by an alkali to be masked by acetic acid, or by the addition of an acetate (which is the mode we recommend), with a portion of its acid set free by the cautious introduction of a minute quantity of nitric acid—the change in the picture is marvellously satisfactory; for now, instead of a picture flat, and too faint for printing, we get an intensity which may be carried to opacity if desired, without any "re-developing," "convertlug," "blackening," &c., &c., with all their attendant risks, uncertainties, and vexations. The change in the colour of the negative is just as extraordinary—the surface appears, when viewed by reflected light, to show objects in almost their

natural colours; indeed, in the case of a landscape, we have often seen them have the effect of views when seen at sunset. This, although so far satisfactory, makes no difference as to its printing qualities, only that when we get negatives with this coloured surface we may be sure the bath is in good working order.

The developer recommended for use with this bath and simply iodized collodion is as follows:—protosulphate of iron, ten grains; glacial acetic acid, thirty minims; water, one ounce; a drop of the strongest liquor ammonia being added when the whole is mixed. If the negative be too dense, the proportion of ammonia is to be reduced; if too weak, increased.

The advantages claimed for the direct negative process, are that the process is simpler, the results are more under control, the exposure not much longer than with bromo-iodized collodion, and that the negatives are better and more vigorous.

We do not intend to enter here into a discussion of a subject we have so often treated, further than to state our conviction, that whilst Mr. Matheson invokes for his favourite process a fresh trial, he does not appear to us to have given the method now almost universally in use, with bromo-iodized collodion, by any means such a fair trial as is necessary for a discussion of its merits. We arrive at this conclusion as we peruse his book. In comparing, for instance, the simplicity of his own process with that now commonly used, it never seems to enter his calculations that negatives are frequently obtained by means of bromo-iodized collodion, with quite sufficient printing vigour, without any process of intensification. As to the comparative excellence of the two classes of negatives, we are scarcely surprised that he should prefer his own and speak of the rough granular looking deposit on the others; for, on examining his instructions for producing negatives with bromo-iodized collodion, we find, what he must pardon us for styling, a general slovenliness in the operations. He says, for instance, "a little old positive bath kept in a small bottle is a very convenient way of having at hand the silver used for blackening." Again, "the pyrogallie acid solution should be rather strong—say, ten grains to the ounce of water, controlled by a little citric acid—say, a lump the size of a horse bean to half a pint of solution." If he have been in the habit of using old silver bath charged with iodide of silver for intensifying, we do not wonder that the negatives have a granular surface; we cannot indorse either his recommendation to use citric acid by the "lump," nor his statement that citric acid gives a colour favourable for printing, as in truth the blue tint it confers readily permits the actinic rays to pass, and practically reduces the strength of the negative.

One of the methods given for intensifying is to pour over a fixed positive "a solution of bichloride of mercury either in alcohol or dilute hydrochloric acid; after the film has been properly acted upon to the satisfaction of the operator, wash off all traces of bichloride of mercury with water; then pour on a very weak solution of hyposulphite of soda, which will turn the deposit into an intense black." Now as bichloride of mercury is soluble in water to the extent of 30 grains to an ounce, a greater strength than it is desirable for photographers to use, the employment of either alcohol or dilute hydrochloric acid is unnecessary and mischievous, as the latter render the film rotten, and the former renders necessary an amount of washing which loosens the film, and thus causes one of the evils, the occasional loss of films, which he charges on the process generally. We might quote more to show that the writer either was not familiar with the process he condemns, or that he had practised it in a very slovenly fashion; but we have said enough on that subject.

In treating of his favourite direct negative process, Mr. Matheson is much more satisfactory, and for those who are wishful once more to try that method we can recommend him as a most satisfactory companion and guide. We must add, moreover, that he discusses the questions with the utmost candour, and straightforwardness, and fairness.

In the printing process he recommends an alkaline gold solution with a little more than two grains of bicarbonate of

soda to each grain of chloride of gold, which, he states, if kept three or four hours before use, tones perfectly, without any tendency to mealiness. It has the disadvantage of not keeping longer than that time. He recommends also the dangerous plan of using old hypo solutions, strengthened from time to time, in order to avoid loss of tone, in preference to the constant use of fresh solutions.

A chapter on Photography in Tropical Climates, based upon the author's own experience in India, is excellent, and only too short. It will be read with great interest by all who wish to practice the art in hot climates; many of the hints it contains may be noted with advantage for observance during the heat of summer in this country. The remarks on glass houses are, for the most part, thoroughly intelligent and to the purpose. The form of room recommended, of which a design is given, is one of the best we have seen. We should have preferred the side lights down to the ground, especially for eard portraiture; but with that exception we consider the room perfect. On another page we give the chapter in its entirety, and are enabled, by the courtesy of Mr. How, the publisher, to place the diagrams, illustrating what to avoid and what to build, before our readers.

ON THE ACTION OF PHOTOGRAPHIC VARNISHES UPON THE COLLODION FILM.

BY DR. D. VAN MONCKHOVEN.

It frequently occurs that the varnish completely removes the intensity of the image on the collodion. The aim of this short article is to point out the cause of this phenomenon, and to indicate a method of remedying it.

When a collodion plate, upon its removal from the camera, is covered with the developing solution, the image, as is well known, gradually appears. Many persons imagine that the image formed penetrates the film, but this is not the fact, for, upon examining the film on the back of the plate, we perceive that the iodide of silver remains perfectly white.

The luminous impression is confined to the surface of the sensitive film, and does not penetrate its substance; besides, the silver deposited by the developer superficially swells the fibres of the gun-cotton, and forms an image in relief.

The developed image may, therefore, be considered as formed of two films; the first, constituted by the pyroxyline and iodide of silver, unchanged; the second, by the metallic silver; some traces of iodide of silver, which, before the development, constituted the most superficial part of the film; and, lastly, a very small quantity of pyroxyline, the fibres of which are distended by the deposited silver.

Now we must not forget that gun-cotton is partially soluble in alcohol, benzine, and several other liquids, especially when they are thoroughly deprived of water. Anhydrous alcohol, at 42°, for example, dissolves a large proportion of pyroxyline, while alcohol at 40° dissolves only traces of it, and alcohol at 36° none at all.

Now, in the manufacture of varnish, it is necessary, in order to dissolve the resins which form their basis, to employ alcohol at 42°. What takes place, then, in making use of such a varnish? Why, it dissolves the superficial part of the collodion film, and the image is either wholly removed, or, as frequently happens, its intensity is greatly diminished. The first case is easily explained; the second is intelligible when we consider that the molecules of silver forming the image are at first spongy, then, suddenly, by the removal of the pyroxyline, reduced to the state of boil, which necessarily opposes fewer obstacles to the passage of the luminous rays. Not only spirit-varnish, but also those containing benzine frequently present this defect, and recently, M. Vidal, in employing the excellent varnish described by us some years ago, viz., amber, torrefied at 300° C. dissolved in benzine—informed M. Deltenre, the

manufacturer, of the fact that the varnish frequently deprived the negatives of their intensity.

At a recent meeting of the Photographic Society of London, Mr. Shadbolt explained the fact in question by the dissolving of the pyroxyline, while, on the other hand, Dr. Diamond and Mr. Wright maintained that the pyroxyline is not dissolved. We perceive that these two opinions are reconcilable. The pyroxyline is removed, but only in small quantity, and the pyroxyline remains, but only the film subjacent to the silver deposited by the developer, and that is the most considerable portion.

According to the explanation we have given of this phenomenon, it is easy to point out a remedy which shall protect the film from the varnish; it is sufficient, upon removal from the washing which follows the fixing, to cover the plate with a solution of gum-arabic, consisting of one drachm of pure gum dissolved in ten ounces of water. In this case, the liquid gum penetrates the superficial film which constitutes the image, and imprisons it, so to speak; and when, after it is dried, we cover the plate with alcohol or benzine varnish, no particle of gum-cotton can be dissolved, and, consequently, the negative loses some of its intensity.

I may add, that this process of a preliminary gumming is employed by many professional photographers, who have noticed the fact of loss of intensity by pure and simple varnishing.

In conclusion, I shall state that a varnish formed only of gum-arabic is bad, because the gum swells in summer, deriving humidity from the atmosphere, and sticks to the positive paper. The varnish of white lac is abandoned, because it must be applied warm; that of amber and chloroform is removed under friction of the finger—deficient, therefore, in hardness; that of benzoin is still worse; finally, there remains the formula we gave some years ago—*torrefied amber and benzine*—which, on the contrary, gives a very fine hard surface, and which does not adhere to the positive paper.—*Le Moniteur de la Photographie.*

RECOVERY OF GOLD AND SILVER FROM WASTE PHOTOGRAPHIC MATERIALS.

BY WILLIAM ENGLAND.*

GENTLEMEN,—It is scarcely necessary to remind you that, in all affairs of business, economy is one of the great objects held in view, either of labour, material, or time; and I think it behoves every one whose opportunities or experience enables him to arrive at facts which result in economy to make known those means. With this view, I propose to occupy your attention for a short time upon a subject which I think is important to all photographers, and most particularly to those whose business is extensive.

I will not try your patience by detailing a long and elaborate account of a number of experiments, with a view to arrive at the easiest methods of recovering the gold and silver from waste material; the few remarks to which I shall call your attention may be relied upon as being purely practical and simple, and I hope may prove of some service to those who have not been able to devote the time and attention necessary to ensure success.

I may here mention, that in the course of the past winter I have operated upon and recovered nearly *one thousand ounces* of metallic silver; in fact, during the dull, short days, when photographic operations are at a stand still, this is rather an agreeable, as well as useful occupation.

The materials we have to operate upon are too well known to need description. We will, therefore, take them in the following order:—

Firstly, Washings from the prints and all solutions that can be precipitated as chlorides.

Secondly, Hypo fixing baths, to which may be added the used-out toning-bath, &c.

Thirdly, Sensitive-paper cuttings, filters and any materials containing silver which can be reduced to ashes; and,

Lastly, Kaolin, which has been used for cleansing the sensitizing bath. This contains a large amount of nitrate.

I shall in the first part of this paper, speak of some of the methods of precipitating and preparing the sulphurets, chlorides, &c., ready for the furnace; and, in the second, the reduction of the same into the metallic state.

The first on our list are the chlorides. The method of precipitation with common salt is so well known that no mention is required, more than that the deposit should be well washed and thoroughly dried.

In recovering the metals from the hypo solutions, Mr. Hardwich recommends that it should be boiled for two or three hours in contact with zinc; other authorities recommend adding to the boiling solution hydrochloric acid. Neither of these methods is found in practice to answer well. With the first it is difficult to get rid of the whole of the zinc; and the second plan is objectionable on account of the large amount of sulphur precipitated with the silver and which gives considerable trouble in the process of reduction. Perhaps there is no better method than the one most commonly adopted, that of adding sulphide of potassium; but care should be taken not to add an excess. A simple way to avoid waste is to test as follows:—After the deposit has subsided test the liquor in a test-tube by dropping in a drop or two of sulphide solution; the result will show at a glance whether the whole of the silver and gold has been thrown down.

Now take another sample, and test with silver, to ascertain if an excess of sulphur has been added; if so, it would be advisable to throw in more of the fixing bath, and allow it to settle before drawing off. These experiments are necessary; for, if sufficient sulphide has not been used, of course the whole of the silver will not be precipitated; and should a large excess have been thrown in, a portion of the deposit would be redissolved, causing a waste.

The silvered paper may be conveniently burnt out in the open air in a sheet-iron box about 3 feet deep by 2 wide. Allow the burnt waste to smoulder for a considerable time, to burn off the charred matter; by so doing, it will take up less space in the crucible in reducing. It is a curious fact that these burnt ashes are very sensitive to light, changing from a light drab to a deep brown in a few minutes in sunshine, proving that the action of the fire in consuming the paper only fuses the chloride, instead of reducing it to metallic particles.

Kaolin, as may be supposed, cannot be readily melted in the furnace; therefore, in operating upon this material, we must proceed in a different manner. A simple and economical method is to place a pound or two in a stone pitcher, and pour in an equal quantity of nitric acid, containing about 25 per cent. of water, stirring well the while. Place the pitcher in a warm place for a few hours, and afterwards add a couple of quarts of water, stirring it well again. Allow the kaolin to settle, and draw off, repeating the operation several times, of course saving the liquid, from which the silver can be precipitated as chloride. Kaolin, treated in this way, may be used any number of times, provided the acid is well washed out.

I will now proceed to the second part of this paper—the reduction of the metals. A good furnace is, of course, indispensable. Black's answers very well; but it is too small to take a good-sized crucible. A furnace may be constructed of a simple form and very cheap with a few fire-bricks. A convenient size is about two feet deep by sixteen inches wide, with an ash-pit beneath. No door will be required, as it may be fed from the top. Half a dozen bricks, cemented together and bound round with an iron band, will form an excellent cover. This furnace should be built where a good draught can be obtained, as the success of our operations will much depend upon having a considerable heat. The

* Read at a meeting of the London Photographic Society, on Tuesday, May 5.

only other apparatus required is a few crucibles, usually called pots, a pair of long pincers, some fluxes, such as borax, carbonate of soda, carbonate of potash, and some nitre,

Now let us suppose everything ready to commence operations.

We will begin with the ashes from the paper, that being the simplest. Weigh out two 21bs. of ashes, to which add the same quantity of carbonate of soda and 1 lb. of carbonate of potash. Afterwards take a well dried crucible, and place it in the furnace, mouth downwards, and build up the fire around it. It is necessary to adopt this plan to prevent the pot splitting; or when, in our innocence, we fondly imagine our smelting operations to be complete, on looking in the pot we discover, not metal, but emptiness, and the silver in the ashes under the furnace. After the fire has burnt up, take out the crucible and place it in the right position, mouth upwards. Now fill it about three parts full with the mixture; again make up the fire to a good heat. After the contents of the pot have melted down, another lot may be added, again making up the fire to the greatest possible degree of heat, and in about an hour our operation will be complete, provided the fire has been properly attended to.

To economise time and material, the pot may be taken from the fire, and the contents poured into an iron ladle, the pot put back into the furnace, again filled up with more material, proceeding as before. On turning out the contents of the ladle, the silver will be found at the bottom of the flux.

In reducing chloride, a different method must be adopted. Mix carbonate of soda and potash in equal quantities, add one pound to one pound of chloride of silver, mix well, and throw into a red-hot crucible small portions at a time; for, if the whole were thrown in at once, the effervescence which ensues would boil over, and cause a considerable waste of silver. It is necessary in these operations to weigh out the materials, and after each one to compare results, to enable us to judge whether our experiment has been complete.

Chloride of silver will yield 75 per cent. of metal, paper ashes about 50 to 60 per cent.; but, of course, much will depend upon its freedom from impurities.

Sulphuret of silver and gold is much more difficult to reduce, on account of the large amount of sulphur in combination. After the precipitate has been thoroughly dried, it must be mixed with an equal weight of nitre, and thrown a little at a time into a red-hot crucible. An iron ladle will be necessary for this purpose. Care must be taken not to put in too large a quantity, or the combustion which takes place will drive the metal out of the pot. When the crucible is full, the fire must be made up, and a good heat maintained for about half an hour, after which the cover may be removed, and a portion of the flux taken out with an iron ladle, to make room for more material, and the same process repeated; after which more flux should be taken out and its place supplied with a small quantity of nitre and some carbonate of soda. This will ensure the whole of the sulphur being got rid of. The fire should now be continued for about a couple of hours.

On removing the crucible from the fire, should the experiment have been successful, the whole of the silver, in combination with the gold, will be found at the bottom of the pot.

The two metals may be readily separated by nitric acid, to which a little water has been added to assist the oxidation. The gold will be left in the state of a fine black powder, which must be carefully separated, and may be converted into chloride by nitro-muriatic in the usual way.

In these remarks, I have omitted many matters of detail, fearing to trespass too much upon your valuable time. I therefore thank you, gentlemen, for your kind attention; and should these observations prove of any practical value, or if there be any question I can answer, it will afford me much pleasure.

A SHORT LESSON IN PHOTOGRAPHY.—No. 13.*

THE pictures have been in the water upwards of twelve hours, and during this interval the water has been changed several times, so that by this process every trace of the hyposulphite of soda has been removed. In large photographic establishments an arrangement is made for washing the fixed prints which is supplied with fresh water from a stopcock connected with the water-works. This apparatus is so adjusted on pivots as to rise and fall like the beam of a pair of scales, and it is put in motion by the weight of the water itself. It consists, in the first place, of a trough of wood of any given appropriate length, as, for instance, three feet; its breadth may be one foot, and its height the same. It is divided into two compartments in the middle, and supported on pivots in the middle of the base-board about six inches above the table or shelf on which it rests; by this means it has an oscillating motion or play of about twelve inches at either end like a see-saw. This trough is placed so that the middle division is, when horizontal, immediately below the stopcock; but when one end is down and filled with water, and the other up and empty, it is evident that if the stopcock be open, the water will flow into the empty compartment until this sinks, which it will do when the other is empty. Each compartment is supplied with a syphon whose arch reaches to near a plane level with the top; the calibre of this syphon is somewhat greater than that of the ingress pipe furnished with the stopcock. Now when either end becomes filled with water, the latter will rise higher than the arch of the syphon, which will then be filled with water. The longer arm of the syphon passes through the end of each compartment and discharges the water from its corresponding end somewhat quicker than the water is supplied to the other end by the stopcock. By this arrangement one end becomes alternately light and heavy, and thus produces a constant oscillation of the whole trough up and down. The prints to be washed are placed in these troughs as soon as they leave the fixing bath, and are thus kept in motion and supplied with fresh water for any length of time. Such a machine is called the *self-acting photographic washing machine*. When prints are thus treated, an hour's washing will remove every trace of the hyposulphite of soda.

They are then taken out one by one and pinned by one corner to slips of wood on the side-walls of the room until they are thoroughly dry. Naturally they may be dried by artificial heat in chambers fitted up for the purpose.

How to Mount Card Pictures.

If four or more pictures are printed on the same piece of albumen paper, the whole piece may be brushed over with a solution of gum arabic and gelatine, or, what is still better, with a solution of patent starch or dextrine such as is used on the back of post-stamps. As soon as it is dry it is placed, with the starch side downwards, on a plate of glass. Then placing a mat with the proper-sized opening, or a piece of glass of the exact size and with accurately ground edges, over each card picture, the latter is neatly and carefully cut out with a sharp-pointed penknife. This act of cutting out the pictures requires considerable dexterity in pressing the plate and making the incision so that the terminal cut is a continuity of the commencement, and that the edge all round is clean and not dentated. A whetstone or hone is a very necessary appendage to the mounting table.

When the pictures are printed singly some artists cut them out before they are brushed over with the starch. In this case they are pasted immediately upon the mounts and passed soon afterwards through the glazing machine. In the former case either the surface of the mounts or the starched surface of the prints is made moist by passing over it a moderately wet sponge, and then the print is placed upon its appropriate position and pressed intimately by the motion of the rollers of the press.

* From *Humphrey's Journal*.

When the artist does not possess such a machine, the prints are brought as before upon the mounts after they have been starched or gummed, and then by placing over each picture a piece of clean writing paper larger than the print, and by holding the first and second finger far apart firmly upon its surface, the print is pressed upon the cardboard by rubbing the space between the two fingers with a burnishing tool or the smooth handle of a tooth-brush. The fingers then assume different positions until the whole print is thoroughly adhesive to the mounts.

When pictures are mounted in this way it is very necessary to remove all prominent particles of dust or sand from the starched surface, otherwise they will spoil the picture by producing similar prominences through the paper of the print.

What to do with the Clippings of Prints.

Spoiled prints, soiled sensitized paper, and the entings of pictures may as well be preserved as not; for the labour consists in simply placing them in some corner or box instead of throwing them away. As soon as the stock is very large, they may be burnt in a clean stove and the ashes collected. These ashes contain silver, oxide of silver, and other combinations of silver, together with the minerals in the paper, as, for instance, lime, &c. The ashes so constituted are pressed closely and firmly together into a Hessian crucible, then submitted to a powerful heat, and thus reduced. Or these ashes may be mixed with the refuse chloride of silver, dried, and then fused with an addition of about one-third their weight of either carbonate of soda or carbonate of potassa.

In large establishments the refuse silver salts, as well as the cuttings of paper, amount to quite a sum annually, and are frequently sold for reduction to parties who make it their business. Where such an opportunity presents itself, it is more advantageous to dispose of the unreduced refuse, than to perform the operation.

And now, dear card picture, I must take my leave, and wish you all the welcome and warm reception that a genial spirit can desire or is wont to meet with. Whether on a mission of love, of grief, or of municipal investigation, your presence is inferior alone to the reality. Is not this true? Witness the beaming smile on the countenance of the dying soldier on the banks of the Rappahannock, as he presses the beloved card for the last time to the last palpitation of his heart. Witness the gentle tears of the widowed mother when she compares the lineaments of her child with the noble features of one that fell in the defence of his country. Witness the easy recognition of an arrant villain by the scrutinizing eye of an adept, glancing from fact to fiction, from the corporeal frame to the pictorial representation. A card picture is a reality! and if the Roman poet had lived in the age of actinic drawing, he would have continued those verses, which Penelope addressed to her lingering Ulysses, which stand thus:—

“Hanc tua Penelope lento tibi mittit, Ulysse.
Nil mihi rescribas ut tamen, ipse veni.”

by saying:—

“If it should happen you cannot, then do the next best in your power,
Send me your picture on card drawn by the rays of the sun.”

COPYRIGHT IN ENGRAVINGS AND PHOTOGRAPHS.

Mr. GAMBART'S industry and perseverance in defending his copyright property have been crowned with remarkable success. Our readers will remember that, some few months since, an action was tried before Mr. Justice Willes, which had been brought by Mr. Gambart for piracy of his two copyright engravings, “The Light of the World,” and “The Horse Fair,” by making and selling small *photographic* copies made from prints taken from these engravings. Mr. Gambart obtained the verdict, with ten pounds damages; but, upon a question of law being raised, whether copying the prints in question by means of photography and selling such copies,

is prohibited within the meaning of the Engraving Acts, the learned Judge reserved leave to the defendant to take the opinion of the Court of Common Pleas upon that point. On Saturday last, the question was argued before the Lord Chief Justice Erle, and three other of the Judges, who were unanimously of opinion that Mr. Gambart was entitled to retain the verdict he had obtained.

This decision is of unusual interest and importance to a considerable number of persons. It remedies the mischief of which the print-publishers have so long and bitterly complained—inasmuch as it clearly establishes that making, selling, or publishing any photographic copy of a copyright engraving or lithograph of any description, if done without the consent of the proprietor of such copyright, renders the offender liable to the pains and penalties defined by the Engraving Acts. The decision thus directly affects the interests of every painter, engraver, photographer, print and photograph seller throughout the United Kingdom. Taken in conjunction with the Act of last session, which, it should be remembered, for the first time created a copyright in pictures and drawings, the decision gives a security to the proprietors of copyrights in British engravings, which they have never hitherto enjoyed. The increased value of pictures and engravings, resulting from that security against the piracy of artistic property will, we trust, be productive of the most beneficial results in the arts of designing and engraving.

It may be useful, at this time especially, to remind artists and the purchasers of their works of the protection the law now enables them to acquire for their copyright property. Under the Act of last session, the exclusive copyright in any *original* painting, drawing, and photograph may be effectually protected in every case where such work was not sold or disposed of before the 29th of July, 1862. If a work has been executed upon commission, then the copyright belongs to the employer, and not to the artist. If, on the other hand, it was not executed upon commission, then the copyright is the property of the artist; but such copyright will become public property, unless at or before the time when such artist first sells or disposes of his work he agrees, in writing, with the purchaser thereof, as to the sale or reservation of the copyright. If the artist reserves it, the agreement must be *signed* by the purchaser; and if the latter is to have the copyright, then the agreement must be *signed* by the artist or by his agent.

But in no case can any legal proceedings for the infringement of such copyright be maintained against a pirate unless that copyright has been *registered* at Stationers' Hall before the act of piracy complained of has been committed. Hence the necessity of registering every original painting, drawing, and photograph as soon as possible. It only remains to add, upon this part of the subject, that by the agreement above mentioned an artist may effectually reserve his copyright for all purposes of *engraving*, where the bargain is that the purchaser shall have the copyright, by stipulating in the agreement that the purchaser shall grant the artist or his nominee an *exclusive license* to engrave the work in question.

To acquire copyright under the Engraving Acts, an engraving or lithograph in which such right is claimed must have been actually made in some part of the United Kingdom; and the name of the proprietor of the copyright and date of first publication of the print must be truly stated upon the plate or block, &c., and printed on *every* print taken from such plate, &c.

All engravings and lithographs not executed within the United Kingdom, are unprotected by the Engraving Acts. The only exception to this rule exists in favour of works of that description under our International Copyright Acts, where such works have been *first published* in any foreign State with which Her Majesty has entered into a copyright convention. Thus, engravings and lithographs first published in France, Prussia, and several other States, may be protected here as to the copyright in them; but to acquire that protection, unfortunately, as the law now exists, a

double set of conditions must be performed: *first*, the name of the proprietor, and date of first publication in the foreign State must be engraved and printed exactly the same as if the print were first published in the United Kingdom; and, *secondly*, the print must be registered and a copy deposited at Stationers' Hall, London, *within three months* after the first publication of such print abroad. Unless all these conditions are performed, the copyright is utterly lost in the British dominions. We call attention to these facts, as they are of much consequence to the proprietors of foreign copyright engravings, whose property therein may with impunity be injured by the photographic or any other process of copying, unless the formalities we have pointed out are accurately performed.—*Athenæum*.

PHOTOGRAPHY IN TROPICAL CLIMATES.*

The difficulties in operating in a hot climate, after once getting on the right track, are not so great as some imagine. We were overwhelmed with difficulties, when we first attempted photography in India. In spite of everything we could try, likely and unlikely, the film would fog on developing. The only remedy we could find answer for a long time was to add considerable quantities of acid to the bath. This certainly got rid of fogging, but the length of exposure was enormously increased. At last it struck us that it was not so much the heat (as we have experimented in an artificially raised temperature), as the *energy and rapidity of chemical action* which goes on in the tropics, consequently if we reduced the number of particles to be acted on, or separated them further from each other, that we should thus neutralize their violent action. The thing was tried and found to answer very satisfactorily, the bath was reduced from thirty grains down to eight or ten grains to the ounce. This to many operators in England may seem incredible, they well knowing what effect such a course of procedure would have on the film here; but even then it was found necessary to allow but a very short time for immersion in the bath.

The strength of developing solutions was not of so much consequence, but even they were reduced with advantage.

Another difficulty to be encountered is the rapid drying of the surface of the film, giving use to fern-leaf markings. We tried, as we had found serviceable here, a pad of wet blotting paper at the back of the glass, but this was of no use. It then occurred to us, from the dryness of the shutter immediately in front of the glass, that it would possibly have a good effect to reverse the conditions. We then scraped the varnish or French polish off the inner side of the shutter, and kept it well moistened with water. This completely remedied that nuisance.

The dark room should be made in the coolest possible place near the glass room, not in it. The glass room should be situated in the shade of a tall house, if possible, to avoid every ray of sunshine. The sashes should be made moveable, so as to allow a good current of air. At certain times of the year, the sun is vertical at twelve o'clock; but the glass room can be so arranged as to be shaded without cutting off any of the effective working light. The only object in having a glass covering at all, is to screen off dust, wind, &c. A great portion of the year there is no rain worth speaking of, and when there is no wind, the sashes may be removed altogether.

One of the most general errors with regard to the construction of glass operating rooms, is that the more glass there is, the quicker will the picture be taken; nearly all glass houses are built of the preceding shape, which we will presently show to be a bad one, both for effect and shortness of exposure.

Light passes through a plane of glass with most chemical effect, when the line of its direction is at right angles to its surface. Such being the case, it is evident that a sitter placed at either end of a glass room constructed as above, can receive no direct light at all (as the light over his head *must* be stopped out, or it will give a person whose hair is black the appearance of having grey hair); all the light which comes to him must have been deflected from its original course, thereby losing a great deal of its chemical properties, besides which it will be found that, however far apart the sash bars are placed (consistent with the necessary strength), they will be found to intercept an immense portion of the light—not from the room, but from the sitter. There it is we want the light, the darker the rest of the room, the better for effect and comfort to the sitter. As the angle of the incidence and reflection of light are known to be the same, it follows as a natural consequence, that where a ray of light from the sky to the sitter has to pass through the glass at such an acute angle, a great portion of it never passes through at all, but is reflected off again. This may be very familiarly illustrated by observing the blaze of light which may be often observed coming from a cottage window (which may be seen for miles), when the sun is shining. This is light which has impinged on the window at too acute an angle to pass through it; for we must recollect that glass, though transparent, has a highly polished surface.

We have found the following shape of glass room, although not so complete-looking on its exterior as the preceding, a very great improvement both in its convenience and effectiveness. The tallest end for the background, B, is square—a great advantage in taking groups—while all the rest of the room not actually wanted for light may be built of any opaque material, to keep out the heat. The quantity of glass surface need bear very little proportion to the size of the room, as ten feet of glass from the sitter (or from A to C) is sufficient, no matter how long the room may be. If the room is sufficiently wide, there need be no side-lights at all. About three or four feet from the background of the under surface of glass, from A to B, may be blackened or built of opaque material, as shown in the drawing. Supposing the room to be twelve feet wide, the highest part of the roof, A, should be about ten, sloping down for about eight or ten feet from the sitter, or A, to the lowest part, C, which may be a flat roof, leaded or tiled, or other opaque material, and which need be no higher than convenient to walk under. The sloping part just over the head of the sitter, A, B, may be hinged as a flap, to be lifted up when the weather will admit, as the warm air ascends to this the highest part. This makes an admirable ventilator, even in this country, in summer. The back, B, should be placed against a tall house if possible, while the rest should be placed so as to have no obstructions.

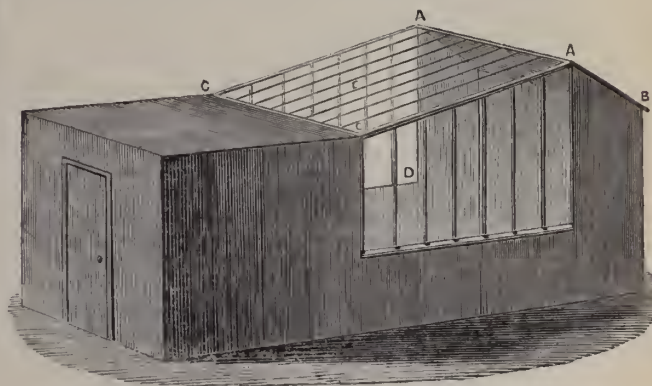

The interior of the room should be coloured a *pale green* colour, without pattern of any kind, as a pattern would distract the eye of the sitter.

The blinds on the top-lights, E, may be made to pull down from A to C; spring-blinds are best, if good. The side-lights, D, may be managed with curtains.

* From "Practical Advice to Amateur Photographers," by Henry Matheson.

We will venture to say, that no one working in such a room as we have just described, and which is equally recommended as the best for efficiency here or abroad, would ever wish to alter it, after experiencing its comfort and rapidity as we have done. To such, however, as are in possession of a house such a house as we first described (as many are from unavoidable circumstances), it can be much improved by painting out all the light with the exception of the proportion shown in the last drawing.

A good plan to keep the collodion and chemicals cool, is to wrap a rag kept constantly wet round the stock bottles, and to keep them in the dark.

As water is not so conveniently laid on in the houses in India as here, it would be as well (as the water is generally brought in skins) to have a large earthen vessel or "chattie" placed on a firm bench higher than the head, and suspend a syphon with a tap and rag, to keep back the insects. This should be frequently cleaned out. The water will keep cooler in the earthen vessel than any other.

In out-door manipulation the operator will have many local difficulties to contend with; but if he keeps to the formulas here advised, he will find very little, if any, more difficulty than in this country.

The light, although the visual rays are very intense, has not so much chemical power on the film as one would imagine. Our idea is, that it is owing to its chemical properties being immediately absorbed by surrounding objects.

FOGGING NITRATE BATHS.*

Among the many difficulties encountered by photographers, probably there are none so general and annoying as "fogging nitrate baths," remedies for which have been proposed and published *ad infinitum*. With one, a certain remedy may prove applicable and satisfactory, while, with another, every effort to obviate the trouble results in vexation and disappointment; and, after repeated trials, the baffled experimenter concludes to send his bath to the chemist, and have the silver taken out. Precipitation in the form of a chloride, and reconversion to nitrate of silver, is unquestionably the most philosophical and certain cure. But in the hands of one who has had little experience in practical chemistry, this course involves great danger of failure and consequent loss.

When a bath becomes foggy, it is a sure indication that organic matter has been introduced into it in some way, and when this organic matter is removed, the silver solution is restored to its normal condition. A plan I have pursued to effect this object, which has in every instance proved entirely successful in point of time, economy, and thoroughness of cure, is the following:—

Evaporate the solution in a water bath, to the extent of one-half its bulk; allow it to cool, and then add as much freshly precipitated oxide of silver as it will take up (a slight excess will do no harm), supplying a small portion at a time, and shaping it up the while briskly; pour the solution into a clear glass bottle, and put it in a position where the sun may be on it until it is perfectly clear, and no further precipitation takes place. Upon first exposure to the sun, the solution will turn of a reddish brown colour, then black. The black sediment (precipitate) is organic matter with its equivalent of silver. To thoroughly accomplish this result may require two or three days' exposure. At any rate, *be sure there is no further precipitation*; then filter it carefully, and add to it about one drachm *kaolin* (china clay); shake it up, and let it stand over night. Now expose it to the sun, as before. Alkalinity may result from the presence of the oxide of silver. If, on testing, such should prove to be the case, remove it by adding one drop of C. P. nitric acid, and mixing it thoroughly with the solution. Now try a plate. Should the solution still show signs of alkalinity, add one drop more of nitric acid, try another setting, until the alkalinity is removed. In the addition of nitric acid, care must be exercised to avoid an

excess, as, in such case, the necessity arises of again adding *more cautiously* the acid.

The recommendation for the above course is its simplicity and certainty. There need be no failure in the adoption of it by the most inexperienced photographer, and certainly no waste.

The oxide of silver may be prepared by adding a solution of caustic potash to a solution of nitrate of silver, and washing the precipitate thoroughly with pure water. Aqua ammonia must not be used in lieu of caustic potash.

It must be borne in mind that the above is only applicable to a bath in which *no acetic acid* has been used. Acetic acid has no business in the bath—it belongs to the developer only.

Correspondence.

FOREIGN SCIENCE.

[FROM OUR SPECIAL CORRESPONDENT.]

Paris, May 13th, 1863.

DR. MONCKHOVEN describes a simple and easy method of analyzing silver baths. Take a glass tube, whose internal diameter is 1 centimetre, close it, and round one of its extremities in the flame of a spirit-lamp, and cut the other with a file, so as to leave a length of 50 centimetres, 20 inches. Weigh successively (1) 30, 60, 90, 120, 150, 180, 210, 240, 270, 300, and 330 grammes (of 15 grains each) of mercury, and introduce, after each weighing, into the tube. On the outside of the tube, mark the level of the liquid with a diamond or steel point; then pour the mercury into the scale, and proceed with the next weighing. After the last weighing, and the eleventh marking, cut the tube with a file just above this last mark; then, with the diamond, write O at the first mark, and successively 2, 4, 6, 8, 10, 12, 14, 16, 18, 20 at the succeeding marks; and, with a compass, subdivide these divisions, and also mark the odd figures comprised between 1 and 19.

On the other hand, take some clean culinary salt and put it into an earthen pot with a cover; place the vessel in a hot oven, or over the fire, and do not be alarmed at the noise made by the decipitating salt. When it is quite dry, weigh 6.9 grammes of it; weigh, also, a gramme of chromate of potassa, and dissolve it in an exact kilogramme of water, by weight, and not measured.

Distilled water, or, at least, rain water, is necessary for this purpose. After filtering, preserve the liquid for use in a well-corked bottle.

To make an analysis of any kind of silver bath employed in photography (even the aceto-nitrate bath), put some of it into the tube, up to the level of the first mark O. It is well to employ, for this purpose, a small glass funnel, with a fine pipe; for it is necessary to operate with great nicety. Pour in the salt liquid, small portions at a time, closing the tube each time with the thumb, and then shaking it. A moment arrives when the precipitate, first of a flesh colour, will become white. Read off, upon the exterior of the tube, the figure which corresponds to the liquid; this is the exact strength of the solution to be analyzed. A second experiment made, by employing very small quantities of the salt solution, especially when compared with the quantity marked by the preceding experiment, will give a more correct analysis.

M. Mc. A. Gaudin, commenting, in *La Lumière*, upon an article in the PHOTOGRAPHIC NEWS upon the new iron developer, says:—The principal advantage of the double salt of iron and ammonium consists in the stability of its composition, which is not influenced by contact with the atmosphere; while the ordinary protosulphate, even in crystals, offers quite a series of bodies more or less energetic. There is, first, the prosulphate, in blue crystals, which possesses the maximum of reducing power; and there is the ordinary sulphate of commerce in large crystals, of a brownish green, which contain a notable proportion of the protoxide salt. In my

opinion, this latter salt is the best, and the uncertain results must be attributed to the variability of the principal salt itself, which retains a definite composition with difficulty. From this fact, it is difficult to admit that the double salt procures a positive sensibility in comparison with the simple salt; but, on account of the constancy of its composition, it contributes better to a preparation possessing properties almost invariable, and permitting the avoidance of the accidental fogging peculiar to the sulphate of protoxide of iron under conditions which have not yet been defined.

Whichever sulphate of iron is employed, it is just the same; but its state in reference to the protosulphate type is unknown, and it is impossible to know the exact proportions of acid and of sulphate to employ, under the same conditions, as with another sulphate. But, in reality, the spontaneous oxydation of the protosulphate in contact with the atmosphere never diminishes its reducing power to the point of permitting its employment without the addition of acid.

SCHERING'S ENAMELLED PAPER.

SIR,—I mentioned a week or two ago in a letter, that I believed Mr. Schering's enamelled paper to contain a preparation of lead.

I have since been informed by that gentleman that such is not the case, and he has requested me to state this to you in the hope that you will give it the same publicity which you so kindly did to my former letter, as it might prove to the detriment of the sale of his paper, were the public to think that it was prepared with lead.

It appears that I was misled in my idea of his paper, owing to a sample which I once tried having turned grey in the fixing bath, but I now find that my failure was owing to my having toned the picture for too long a time.

May I request you to be kind enough to insert this communication in your next week's publication?—I remain, dear sir, faithfully yours.

N. JOCELYN.

Berlin, May 11, 1863.

Photographic Notes and Queries.

ANOTHER CAUSE OF FADING OF POSITIVE PRINTS REMOVED.

SIR,—I should propose that some very extra thick paper (about as substantial as the card used for mounting) might be made and albumenized in the usual way, when cut to the size required it might be printed upon no more than the exact size of the *carte de visite* (2½ by 3½ inches) by masking the margin all round of the respective picture on the negative: whereby much work, time, expense, &c., would be saved, besides the liability of the fading of the print by the more or less acid condition of the gum, paste, or other medium in mounting *cartes de visite*.

Should you think this of public interest you are quite welcome to it.—Yours respectfully,

P. T.

[We fear that the operation of printing on card or stout paper, together with the masking and necessity of preserving clean margins, &c., &c., would involve manipulatory difficulties which would outweigh the advantages to be gained; but the plan may be worth trying.—ED.]

Talk in the Studio.

AMATEUR PHOTOGRAPHIC ASSOCIATION.—A very handsomely bound album, containing a choice selection of photographs, by members of the Amateur Photographic Association, was presented to His Royal Highness the Prince of Wales, on Friday last, by Lord Caithness, accompanied by Mr. Melhuish, the Hon. Secretary of the Association. His Royal Highness was much pleased with the album and desired the secretary to express his gratification and pleasure to the council and members. A very large number of fine negatives have been, we are informed, sent in this year by members, many of which are from abroad, and include scenes in Egypt, India, Java, Canada, Italy, &c.

MR. VERNON HEATH'S EXHIBITION.—On Friday and Satur-

day last, Mr. Vernon Heath invited his friends to a private view of his latest landscape photographs, at his gallery, in Piccadilly. The pictures consisted of a new series of the castle and park, at Windsor; of additional views of, and around, the Grange, the seat of Lord Ashburton; of some charming pictures of Burnham Beeches, and the neighbourhood. All the pictures were characterised by the combined delicacy and brilliancy by which Mr. Heath's photographs have been distinguished, with the added charm now conferred by the presence of natural clouds and sky.

PHOTOGRAPHIC PIRACY OF ENGRAVINGS.—*Court of Common Pleas, Westminster, May 8.* (*Sittings in Banco, Easter Term, before the Lord Chief Justice ERLE and Justices WILLES, BYLES, and KEATING.*) GAMBART V. MAYNE.—This was an action for the infringement of the copyright in the "Light of the World" by the defendant, a bookseller at Exeter, for selling a photograph of that engraving to the plaintiff's attorney's son. The defendant set up the defence that he had denied having any copies to sell when asked, but that his daughter, who was present, said she had had a small copy given to her, which she offered to give the plaintiff's attorney's son, who, however, insisted upon paying for it, and the defendant's daughter then said if he paid for it she would have the money, and a person in the shop said, "Well done, young lady, I am glad you insist on your rights." The jury, therefore, found a verdict for the defendant. Mr. Brandt now moved for a new trial, on the affidavit of a person in Exeter that he had seen photographs of the print in the defendant's shop window, and that the defendant had himself shown him copies and offered to sell one to him, and had boasted of selling them. The court said the application was too late. The witness might have been called at the trial.—*Rule refused.*—*Times.*

AID TO TONING.—Mr. H. Cooper sends us the subjoined:—The following suggestion may, I hope, be of some use to your readers. During the preliminary washing of photographic prints, dab the surface with a clean sponge, before toning. This will effectually remove any deposit of chlorides, &c., from them, and materially conduce to even toning. If, whilst toning, any deposit falls, it can be removed in the same way. When prints are left to *soak* in water, they should be face downwards.

ENGLISH PHOTOGRAPHY IN FRANCE.—The Paris correspondent of the *Daily Telegraph*, speaking of the present Academy Exhibition, remarks that English photography takes the highest position there. He says:—Adjoining the picture gallery is a vast and splendid display of photography, of which, as the catalogue is not yet printed, I cannot speak with certainty either as to performances or artists; but I am sufficiently a judge, and my opinion was confirmed by native and foreign artists, to say that England bears off the palm. Mr. Robinson's picture, "Bringing Home the May," was greatly admired as an elaborate and highly-finished work. The "Views in the Pyrenees," photographed for the Emperor by Mr. Maxwell Lyte—who, with a classical and original if simple wit, writes "*Lux fecit*" at the bottom of his pictures—are very true to nature and very beautiful, but they and all the other photographs want what is so striking in the "Views near Naples," sent over by Colonel Stuart Wortley. This gentleman seems especially to have studied the effects of atmosphere and of water, and in his pictures, instead of the hard straight line which in photography defines the boundary between the view itself and the blank white which stands for sky and water, you have the varied light and shade of the passing clouds and the changing face of the rippling sea. The former is especially to be perceived in the "Sunrise during the Eruption of Vesuvius;" the latter effect is wonderfully produced in the "Wave rolling in," which is the gem of the Photographic Exhibition.

RAPID TANNIN PLATES.—A correspondent in Berlin writes as follows:—"I have been trying with considerable success the rapid tannin process, developing with ammonia. There is with me always a slight veil, at least, with Ponting's collodion, but this I can altogether get rid of by using a collodion containing a good deal of free iodine, but at the expense of rapidity. I should like much to know Mr. Hurst's method." Our correspondent should try the addition of bromide to the collodion in question. We hope shortly to have Mr. Hurst's permission to publish his method.

MOUNTING PHOTOGRAPHS.—A correspondent says,—"Perhaps the following will be of use to some of your correspondents, as I think it is generally considered that glue is the best substance for mounting prints, but not much used by amateurs on account of the trouble of preparing it every time it is required to mount

a few prints. If a small quantity previously melted be poured into a bottle and allowed to cool it may be got ready for use in two or three minutes by standing the bottle in hot water."

PHOTOGRAPHY FOR TOURISTS.—A new work on "Dry Collodion Processes," written with an especial view to the wants of tourists and of missionaries and scientific travellers, by Dr. Kemp, of Cambridge, is announced as in the press, and shortly to be published.

To Correspondents.

TYRO TANNIN.—Our own experiments with the recent variations of the tannin process have not been extensive. For the purpose of obtaining the best information, we have submitted your queries to Major Russell, and hope to be able to give you his answer in our next.

F. VINCENT.—The collodion to which you refer has many excellent qualities; but unfortunately some samples give the mottled reticulated effect which you describe. Reducing its thickness by the addition of equal parts of ether and alcohol will decrease the tendency, but we fear nothing will entirely remove it when present.

A. POOL AMATEUR.—We believe that pitch alone is used for attaching lenses to the holder in grinding. 2. Blotting-paper as a lining for your plate-box will be quite harmless. 3. There is no work treating especially of photographic lenses, nor any work on optics giving much attention to the subject. The only published information on the subject is scattered about, and is for the most part meagre, and often unsatisfactory and untrustworthy. There is no periodical called "The Optician." 4. A quarter-plate portrait combination for 13s. 6d. cannot, in the nature of things, be very good. It is quite possible that the lens No. 1 in the catalogue you name may answer your purpose, but you must remember that no ordinary quarter-plate lens is well calculated for taking card portraits of standing figures. To be well suited to the work in question a special construction is required for lenses of such short focus. For sitting figures they may answer, if good, very well, and for standing figures by using a very small aperture, which of course increases the time of exposure. We have every reason to believe the dealer you name to be a respectable man. But bear in mind in reference to lenses, as to everything else in the world, "the worth of a thing is just what it will bring." A first-class article will always command a good price, a moderate article a moderate price, and a bad one a bad price. The authority whose words you quote in favour of cheapness is a very insufficient authority on the subject of lenses, and his words were disproved by the illustrations brought forward at the time. The thorough testing of a lens is not a task which can be successfully undertaken by an entire novice. Your best plan will be to write to the dealer, as you propose, telling him the circumstances and asking him to select you one.

R. T.—So far as we can see from your specimen your lenses are placed in the right position in the camera, but the partition in the camera does not come sufficiently up to the ground-glass to prevent one image impinging on the other, and so causing the blurred space between them. When the lenses have no lateral movement, the usual distance between the lenses is 34 inches, so that the centre of each image may fall on the centre of each half of a 63-inch plate.

G. A. B.—The small, irregular, white patches which you describe are doubtless reduced silver, and may proceed from several causes. The most common are contact with some reducing agent on the frame in the dark slide, insufficient acid in the bath, or the presence of organic matter, too long a time between exciting and developing; this latter may be the case without actual drying of the film in the place. 2. We are very familiar with the brown or red deposit on the shadows which you describe, you will find it fully treated on page 361 of our fifth volume, and on page 45 of our present YEAR-BOOK. The plentiful use of citric acid, or, better still, a wash of iodine solution previous to intensifying will prevent its occurrence. 3. B, probably of the makers you name. 4. We use plates 7½ by 5, and 5½ by 3½. 5. The washed collodion process as described by Mr. Hislop gives the best results we have seen.

ALPHA.—A little more intensity in your negative would make the print not quite so heavy, or a little less printing with the present negative might be better. But the picture is by no means bad. We cannot tell you of any simple or easy mode of ascertaining whether engravings are copyright, but as a general principle you may presume that all published within the last twenty-eight years are so.

A. BEGINNER.—The printing and tone of your print are not at all bad—the hardness is in the negative. In the toning formula you mention, the proportion of carbonate of soda is not so large as to be dangerous, but the acetate bath is better. If you get better and softer negatives, and print as well as hitherto, the results will be good. The price of our ALMANAC is one shilling. The lens to which you refer will answer for a beginner.

D. DUNNAN.—We are not aware whether any of Liesegang's enamelled paper is to be had yet in this country. Your results with Schering's are very good. What method do you use?

SPOTTY PRINTS.—The defect in the prints enclosed is meanness. The best remedy we know is slow toning, and the use of toning solution a few days old. A variety of remedies have appeared in our pages, but it sometimes happens with some samples of Rive paper, that all fail.

A. LUNATIC.—The Rive paper, highly albumenized, is sometimes very liable to blisters, especially when the toning and fixing solutions are decidedly alkaline. In order to get black and white tones you must use intense negatives, and print deeply. Any toning process will then give you black tones. The only means of preventing the prints becoming too much bleached in the fixing solution, is deep printing and toning, so as to allow for the inevitable bleaching.

M. D.—Your nitrate bath is surcharged with iodo-nitrate of silver. Dilute it with an equal bath of water, which will cause a precipitate; filter, and add sufficient silver to make up the proper strength.

M. AMBO.—With some samples of paper it is impossible to prevent very considerable reddening in the hypo bath, and in such case a change of paper is the only remedy. But it sometimes happens that when the toning is

conducted very rapidly a deceptive black colour is obtained which rapidly disappears in the fixing bath. Use the acetate bath, tone a little deeper, and, if necessary, change the paper.

PYAO.—The stains on your pictures appear to arise from the developing solution running back from the edges of the plate in greasy streaks. The camera used cannot have any influence in the matter so as we can see, unless the plate rests on an edge all round, instead of at the corners only, which might affect the matter. You had better practise a little longer before seeking an engagement as operator.

W. H. H.—The black deposit thrown down is metallic gold. We have never had such a deposit with the acetate bath; try using less of the acetate, or another sample.

T. A.—We presume Mr. Glaisher's opinion as the nature of light is that universally held at the present day, known as the Undulatory Theory, and of which the Astronomer Royal, in his tract on the subject, says it is "certainly true," and possesses "the same claims to attention as the 'Theory of Gravitation.'" This theory supposes that the sun, as a luminous body, communicates an undulatory motion to an elastic ether which pervades space, and that the different coloured rays are due to the length of the waves or undulations; the red ray having the longest waves and the smallest number in a given space of time; and the blue ray the shortest waves and greatest number in a given space of time. As this is a well proved theory, confirmed by its explaining a number of incidental phenomena, and is universally accepted, we have no doubt that it is the view held by Mr. Glaisher. Should this not be the case, we have no doubt that he will inform you, on application. You must bear in mind that a subject which has been carefully investigated by the ablest men of the day, with the best possible facilities for its examination will not be lightly set aside. We cannot of course offer any opinion upon your ideas as briefly indicated in your note.

L. L. L.—The simplest mode of giving a dead black surface to paper is to brush it with a mixture of lamp-black and size. For rapid drying, a mixture of lamp-black with very little white lead, and turpentine will answer. 2. Wherever the word "part" is used it may mean grains, drachms, ounces, or any other quantities at the choice of the operator. It is the simplest possible manner of stating a formula, adapting itself to the commonest intelligence. Thus, the formula you quote, "100 parts of sulphate of iron in 500 parts of water" may be 100 grains, or drachms, or ounces, in 500 grains or drachms or ounces of water; if grains be selected the proportion will be at the rate of one in five, or, say 12 grains in a drachm of water. The only thing to be remembered is to use the same "part" throughout, by weight in solids, and measure in liquids, unless "parts by weight" are specially stated, in which case you must weigh. Where the term per cent. is used it is equally simple: a solution of 5 per cent. contains 5 grains to the ounce of water. Thus a silver bath of 5 per cent. contains 24 grains to the ounce, being 5 multiplied by 4 8/10ths. Where French formulæ are stated according to their decimal system of weights and measures, it is difficult to state them exactly in English figures without troublesome fractions, but where stated in "parts" and "per centages" the matter is very simple, and need merely requires the exercise of a little intelligence to understand them.

R. T. L.—Judging from the print received you have too little direct light and too much diffused light; but the negative appears to have been much over-exposed and under-intensified. So far as you state, your chemical conditions are all right, but the print is very poor, and it seems difficult to say with certainty the source of the error. Try with a much larger stop, and short exposure. If you send us a further example state exact time of exposure.

SOA.—Hollingsworth's paper may be used with resin; but the Rive paper gives the best results for the purpose. You may purchase the solution ready prepared, or you can get the materials, as described in our pages, of any chemist. It is quite possible to get pure whites with resinized paper.

W. D.—The value of negatives, and the facility of disposing of them, will depend entirely upon the subjects. If the subjects are popular, the negatives, or prints, from them will, doubtless, sell.

F. L.—We only know three causes for the defects of which you complain, viz., dirty plates, a bath too acid, or defective collodion. There are other minor causes which will tend to the same defect, but these are the chief causes. When the tendency exists, short exposure and over-pushing of development will increase the tendency. We fear, in this case, the collodion is the cause. No. 174 containing index to Vol. v. is, unfortunately, out of print.

T. G. sends a piece of glass flashed with silver, and having the peculiar mottled appearance characteristic of the best actinic qualities, has been sent for spectroscopic examination. It is seen to cut off in a very perfect manner all the chemically acting rays, and will answer very well for glazing the windows of a dark room.

CONSTANT SUBSCRIBER.—For camera printing of transparencies, the lenses should be placed upon a sliding front, so as to admit of a lateral motion, separating them more or less, as needed. This plan has many advantages, and permits a slight enlargement or reduction of the copy, which is often desirable. The distance between the two images on the transparency should be about 23 inches from centre to centre. You may use the lenses to which you refer, for producing the transparencies.

F. G. WHAITE.—We handed the five shillings to Dr. Diamond, for your share in Meagher's camera.

Several Correspondents in our next.

Photographs Registered during the Past Week.

- MR. JOSIAH GROOM,** Wyle Cop, Shrewsbury,
Photograph of Lord Hill Hawkstone.
- MR. A. S. WATSON,** 2, Regent Road, Great Yarmouth,
Two Photographs of Percy Rosell, *The Infant Wonder*,
Photographs of the Officers of the East Norfolk Militia.
- MESSRS. W. AND D. DOWNY,** 9, Eldon Square, Newcastle-on-Tyne,
Photograph of Newcastle from Gateshead,
Two Photographs of Rev. James Pringle.
- MR. THOMAS GULLIVER,** 18, Union Street, Swansea,
Photograph of Rev. Latimer Maurice Jones.

THE PHOTOGRAPHIC NEWS.



VOL. VII. No. 246.—May 22, 1863.

CONTENTS.

	PAGE		PAGE
Increasing or Reducing Intensity of Varnished Negatives.....	241	Notes on the Collodio-Albumen Process. By W. D. Clark.....	247
The Enamelled Photographic Papers	242	Proceedings of Societies	248
Photographic Chemicals	242	Correspondence—Foreign Science, &c.....	250
Double or Fancy Printing. By R. Harmer	243	Talk in the Studio	252
Researches on Positive Paper. By Dr. Schnauss.....	243	To Correspondents.....	252
Copyright in Photographs	244	Photographs Registered during the past Week	252

INCREASING OR REDUCING INTENSITY OF VARNISHED NEGATIVES.

WHEN a negative is varnished, its defects, if it have any, are generally considered as past remedy. It frequently happens, however, especially to amateurs, that the real printing value of the negative is not certainly ascertained until after it has been varnished and proved; it may then turn out that the deposit, which looked so comparatively thin, is so non-actinic that it prints hard; or, that notwithstanding an apparently dense deposit on the high lights, either from this density being factitious and permeable, or from the presence of too much deposit on the shadows, the prints are tame, flat, and wanting in contrast. It sometimes happens, moreover, that the negative, which really possesses a true relation of contrast in light and shadow before it is varnished, becomes, through some peculiarity in the film, so permeated and saturated with the varnish, that the opaque spots of high light become more than semi-transparent. All negatives are more or less reduced in intensity by the varnish, but in some instances the varnish appears to remain entirely on the surface, simply acting as a transparent protective film, affecting the printing character of the negative in a very minor degree; whilst in others, where the deposit is powdery and permeable, the intensity is considerably reduced. Thus, from a variety of causes, especially in the hands of the inexperienced, a remedy for such defects, a means of altering the intensity of the varnished negative, becomes a valuable power.

Various modes have been tried to remedy defects of intensity in varnished negatives. If what are termed "crystal" or "amber" varnishes have been used, the solvents of which are chloroform or benzole, the varnish is comparatively easily removed by repeatedly flooding the varnished surface with one or the other, especially with the chloroform; but with spirit varnishes, which are most commonly used for negatives, the case is different. The varnish once set is not easily entirely dissolved again, and even after long digesting with strong alcohol, and repeated washings with the same, a white powdery deposit remains, which seems so incorporated with the collodion film, that it is impossible to remove it. The remedy we are about to describe especially refers to negatives varnished in this manner, with any of the alcoholic or spirit varnishes in the market. Proceed as follows:

For a thin Negative.—Cover the varnished film with absolute or strong alcohol—methylated spirit will of course serve—so as to slightly soften and render permeable the varnish. Then take a weak solution of iodine, in alcohol, from four to six grains to the ounce, and pour over the plate. If the negative be thin and poor, giving prints lacking contrast, let this solution only remain on the film a few minutes, watching its operation carefully. An increased density is the result of the application, and a change of the colour of the deposit. The dense parts which in a weak negative are generally of a grey colour, become of a deep olive tint, which is very non-actinic. The film is then to be washed

quickly again with alcohol, and dried by gentle heat. It may be again varnished, but this it rarely needs, for in truth scarcely any trace of the varnish already there has been removed by the operation. We have produced by this means negatives giving brilliant prints, which before were so thin and flat as to be entirely worthless.

For an Over-Intense Negative.—Proceed in the manner just described; but instead of pouring off the iodine solution as soon as the non-actinic olive tint appears, continue its application, the colour of the deposit will become gradually a deep yellow, then of a primrose, and finally white. It may be stopped at any of these stages, just as the character of the negative and the density of the existing deposit may require. It is evident that whilst a dense deposit of a black or non-actinic colour may give very hard unsatisfactory prints, the same kind of a deposit when changed to a colour more permeable by light may give soft round good prints. The exact stage, then, to which the colour must be carried will depend on the amount of density present and the result desired; a little judgment must therefore be used. The film must then be washed with alcohol, as before described, dried before the fire, and in this instance varnished, as the prolonged treatment with a strong spirit will have removed a considerable portion of the varnish at first on the film.*

The same method both for increasing or reducing intensity, may be followed, using an alcoholic solution of bichloride of mercury, instead of iodine. The first application in this instance increases the density of the deposit and makes it of a bluish-black colour, not so non-actinic, however, as the olive tint produced by iodine. The prolonged action of the bichloride is similar to that of iodine finally turning the dark deposit light coloured, and reducing its printing intensity. The use of the mercury has, however, some objections which the iodine is free from, and we recommend the latter.

The method we have described especially refers to negatives produced by a deposit of silver only; but it is not less applicable to those which have been intensified by mercury and an iodide, or by other means; the principle of its operation being the same, some slight modification in the exact treatment being in some instances rendered desirable by the especial features of the case, which must be suggested by the judgment of the operator.

We may remark in conclusion, that, according to the old adage, they who are good at excuses are seldom good at anything else. In like manner they who are good at expedients are rarely skilful in dispensing with them, and whilst we furnish expedients for emergencies, we strongly counsel young photographers to avoid the necessity for them; to acquire as far as possible a certain and exact mode

* In a paper read by Mr. Berry some nine years ago before the British Association, he suggests that when a film is so tender as not to permit intensifying with aqueous solutions without being disrupted, it may be varnished and then intensified with alcoholic solutions of chloride of gold and sulphide of ammonium applied in succession, but we cannot recommend the plan, which, for various causes, never came much into use.

of operating, which places little reliance upon, and has little need for, after "dodging" of any kind. William Cobbett, in advising the young literary student to acquire a certain and exact habit of writing, recommends him never to erase or alter a word, but to compel himself to send forth his matter as first written, with all its imperfections, so that the mortifications he must suffer, for awkward blunders, may so conduce to caution that he will gradually acquire a habit of precision and exactitude which requires no correction. We do not exactly give this counsel to young photographers; we recommend them rather to destroy with ruthless hand their first crudities. But we do recommend them to acquire habits of certain manipulation, and to remember that in placing in their hands expedients of any kind, they are to be regarded as reserve power to be used in emergency, and not as encouragements to carelessness in one operation because the result can be modified in another.

THE ENAMELLED PHOTOGRAPHIC PAPERS.

We have already stated that some of the enamelled papers are prepared with oxide of zinc. We are now in a position to state that our original conjecture as to the nature of the enamel in some other specimens is correct. A sample we placed in the hands of an eminent analytical chemist proves to be prepared with sulphate of baryta in combination with albumen. The material used is probably the ordinary mineral white (powdered heavy spar, or native Ba O SO_4), which is in this country largely employed in adulterating white lead. Mr. Cooper's experience that it is insoluble in dilute mineral acids would be quite consistent with this material. We see no reason to apprehend any injurious influence from it, either to the silvered bath or to the finished photograph.

PHOTOGRAPHIC CHEMICALS.

THEIR MANUFACTURE, ADULTERATION, AND ANALYSIS.

DISMISSING silicic acid for the present, we will pass over a series of metals which are either too rare or not sufficiently important, to require treatment in these chapters.

The next body which claims attention from the importance of many of its compounds to the photographer, is chromium.

This metal forms two or three oxides of interest to the photographer, the brown oxide, sesquioxide, and chromic acid. We will, in this case, reverse our usual order in describing metallic compounds, and treat of the acid first, as it is this body, in combination with potash, which is mostly used for photographic purposes, the lower oxides being generally the result of the action of light. Chromic acid forms carmine-coloured needle-shaped crystals, rapidly deliquescing in the air, and dissolving very easily in water, forming a dark reddish brown, or lemon yellow solution. The concentrated acid corrodes paper like oil of vitriol, and when in dilute solution, it likewise attacks paper and other kinds of organic matter, especially when aided by light or heat, becoming converted into the brown oxide or the green sesquioxide, according to the extent of the decomposition. Chromic acid is too energetic and unmanageable an agent to be used in the pure state for photographic purposes. It can, however, be converted into an acid salt with potash, in which form it possesses very valuable properties. Bichromate of potash is the name given to this compound. It is composed of one part of potash and two parts of chromic acid. In most places, bichromate of potash can be purchased ready made, and then nothing more is necessary than purification, before it can be employed for photographic purposes. It may, however, sometimes happen that bichromate of potash may be wanted when only the materials for making it can be obtained, and as its preparation is not difficult when the ordinary resources of a laboratory are available, we shall now give the most approved method of manufacturing this salt direct from the ores. Chrome iron ore (a mixture of

sesquioxide of chromium with protoxide of iron) is finely powdered and ignited with an equal weight of nitre. The mass is raised to a bright red heat in an earthen or iron crucible, and kept at that temperature for a considerable time. It is then boiled out in water and filtered from the insoluble portion. The aqueous solution contains chromate, silicate, and albuminate of potash, together with nitrate and nitrate of potash. To this add nitric acid, until the alkali in the liquid is exactly neutralized, the acid being added in small portions at a time, until the lemon yellow colour of the liquid begins to change to reddish yellow. The alumina and silica will be by this treatment precipitated and can be filtered off. Evaporate the solution to the crystallizing point, and separate the resulting yellow crystals of chromate of potash. This salt is liable to contain as impurities, silica, alumina, chlorine, and sulphuric acid. From the first two it is separated by repeated crystallization, and the sulphuric acid is removed by adding a little nitric acid and adding nitrate of baryta until there is no further precipitation of sulphuric acid. To the filtrate nitrate of silver is added as long as chloride of silver is formed; after which the solution is filtered, evaporated to dryness, and the residue ignited in a platinum crucible. The residue is dissolved in water, and the solution left to crystallize. Yellow chromate of potash has an alkaline reaction and a cooling persistently bitter and metallic taste; it is permanent in the air, it is tolerably soluble in water, dissolving in twice its weight at the common temperature, and in about $1\frac{1}{2}$ times its weight of boiling water. It is insoluble in alcohol. It possesses remarkable colouring properties: one part of the salt imparting a distinct yellow colour to 40,000 parts of water.

The mono-chromate of potash is very little used in photography in comparison to the bichromate; it is, however, the salt from which the latter compound is always prepared. Take a saturated solution of yellow chromate of potash, add nitric acid to it, and evaporate the liquid at a gentle heat to half its volume: bichromate of potash crystallizes out on cooling, together with nitre. The two classes of crystals are so dissimilar to one another that there will be no difficulty in separating the two salts by mechanical means. The bichromate forms bright-red rectangular, four-sided prisms, whilst the nitre occurs in smaller colourless crystals. The red salt must be redissolved in water and purified again by crystallization. It crystallizes very readily in large prisms which have a cooling, bitter, and metallic taste, redden litmus, and are permanent in the air. When three parts of this salt are heated with four parts of oil of vitriol oxygen gas is evolved. According to Balmain, this method gives perfectly pure oxygen, and at a cheaper rate than when chlorate of potash is used.

The great use of bichromate of potash in photographic operations is due to the ready way in which it parts with some of its oxygen to organic matter under the influence of light. Bichromate of potash may be looked upon as containing one part of chromic acid in the free state. Now chromic acid has a large quantity of oxygen locked up in it (three equivalents of oxygen to one equivalent of chromium) and it is somewhat of an unstable compound, having a tendency to give up oxygen and pass to a lower state of oxidation at the slightest opportunity. When placed in contact with an organic substance, such as paper, gelatine, leather, horn, parchment, the skin, &c., the oxygen of the chromic acid is ready to unite with the carbon and hydrogen in these bodies. The change goes on, however, very slowly in the dark, requiring the stimulating action of light to set it up, but under this influence it speedily passes to the state of brown oxide Cr O_2 , and then to the sesquioxide $\text{Cr}_2 \text{O}_3$.

By some chemists the brown oxide is looked up as a compound of chromic acid with sesquioxide of chromium. This appears a very reasonable view of the question. Chromic acid forms salts by union with most, if not all, bases; and on the other hand chromic oxide (sesquioxide of chromium) forms salts by union with most acids. Why, therefore, should not chromic acid form a salt by union with chromic

oxide? In fact this is what takes place when neutral chromate of potash is added to a neutral salt of sesquioxide of chromium, a chromate of chromium is precipitated in the form of a yellowish brown powder. According to this view then the brown binoxide of chromium Cr_2O_3 would be represented by the formula Cr_2O_3 , Cr_2O_3 which equals Cr_3O_6 or three times Cr_2O_3 .

This, then, the formation of brown chromate of oxide of chromium, is the first result of the action of light upon a mixture of bichromate of potash and organic matter, and occasions the brown tint left behind in the paper when the chromate of potash and the carbonate of potash (the carbonic acid being derived from the oxidation of the carbon of the paper) is washed out. If the action of light is allowed to proceed further, the deoxidation ultimately proceeds to the greatest possible extent, and the chromic acid is entirely reduced to the state of sesquioxide of chromium. This has a green colour, and its presence may often be observed in photographs printed in this manner. The reduced brown oxide of chromium, just mentioned as having the properties of a salt, reacts in several ways, like a combination of an acid and a base, and when washed with various metallic and other solutions, gives rise to other insoluble metallic compounds of various colours, by a process of double decomposition. Hence the numerous bichromate of potash printing processes in which variously coloured positives are produced. So far, then, for the action of bichromate of potash upon paper under the influence of light.

Upon gelatine, in its numerous forms of gelatine, isinglass, glue, and the allied bodies, gum, &c, another action takes place at the same time. The reduction of the chromic acid is effected in the same manner, but the oxygen which it loses attacks the gelatine and converts it into a slightly different chemical substance, rendering it partially or entirely insoluble in water, and unacted on by that menstruum.

DOUBLE OR FANCY PRINTING.*

BY R. HARMER.

In complying with the request of your Committee, to describe the method I adopt in double or fancy printing, I will endeavour to be as practical as possible in what I have to say. The proofs in illustration I have purposely taken from the same negative.

The first I would call your attention to is printed as the negative gives it—such a print as I should receive were I to send out the plate and order a dozen to be printed. You will see that it has an amateur background of brown paper, rough and inartistic. It was taken out of doors. This being altogether unsatisfactory, we proceed to make a vignette of it, for which purpose I prefer placing in front of the glass a piece of brown paper, with an aperture filled in round the edges with wool, considering that a much more artistic vignette is produced in this way than by using the vignette glass, which merely gives a shaded oval. With the paper vignette you can, during the printing, enlarge the aperture and vary the effect.

While making these remarks I must beg of you to imagine that a vignette proof has been printed, which I now remove from the frame, and in place of it put a mask of black paper and again place the print in a frame. The parts required to be kept from the action of light are covered by a small piece of wool, which may be made to adhere to the glass by slightly damping as far as the outline of the figure. The wool should then be pulled out to a thin film, to ensure softening into the tinted ground about to be produced. The frame is now ready to be exposed again to the light, which should be done in the shade, as it gives greater control over the tint, and the necessary softening of it into the vignette. Two or three minutes (keeping it moving all the

time) will generally be found sufficient to produce the depth of tint required.

The proof now shown will be the result. Other shapes for the masks will suggest themselves, this being entirely dependent on the taste of the printer. Should fancy lead you still further, it may be done by preparing an ornamental design, bearing in mind that what is black in the design will be white in the finished proof. The ornamental mask thus prepared, nothing remains but to use it in the same manner as the mask of black paper before described. Practice will alone tell the depth necessary to print. One tint and one shape will, as a rule, give the best results; the danger to avoid is over-doing it.

I do not think that this style of printing will be of much value commercially, on account of the care and attention required; but to amateurs whose negatives, for want of the necessary appliances, are imperfect, and who desire to make the best of them, I would recommend them to give it a trial, feeling assured they will find an opportunity for the display of artistic taste, and, at the same time, save many of their negatives being cast aside as worthless.

For the information of some who have been making inquiries as to when I first made use of this style of printing, it was when photography was styled photogenic printing. Leaves, lace, and feathers, being about the only objects copied, my first vignette was a leaf, and when printed, a perforated card, with a lace border, was laid over it, and again exposed to light, which I presume may be called double printing. This must have been about twenty-five years since, so that there is nothing new in it; it is merely revised with improvements, and very possibly others may have done the same thing.

It is a frequent occurrence, both in science and art, for two individuals to be working out similar ideas. I was struck with this on reading in last week's PHOTOGRAPHIC NEWS a letter from America by Mr. Thompson, in which he states that Mr. Moran, of Philadelphia, had made some moonlight pictures by double printing; singular to say, some months back I prepared the cloud sketches now shown for the same purpose, but have made no use of them for want of a suitable negative—a negative which prints hard, giving a white sky, would be suitable for the purpose, and no doubt some fine effects may be produced.

In conclusion, I have to thank you for your attention; and if I have omitted describing anything with sufficient clearness, I shall be pleased to answer any inquiries.

RESEARCHES ON POSITIVE PAPER.

BY DR. SCHNAUSS.

I PUBLISHED, in the *Moniteur de la Photographie*, during the year 1862, an article, "On the Effects of Affinity in Photography," and among other operations, I spoke of gold toning. I endeavoured to show that the photographic proof, or a piece of paper prepared photographically, exposed to the light for a certain time, contains on its surface silver in the metallic state, that is to say, perfectly reduced. Similar researches, I know, have been frequently made, but not from the point of view I take in seeking to establish that in toning, by means of the alkaline gold toning bath, not only is the gold deposited upon the paper, but that also an equivalent quantity of silver is converted into chloride of silver, in the same manner as when a metal is separated from its solution by another metal which is more strongly electro-positive. It is only pure metallic silver that can accomplish this, and not sub-chloride of silver. My researches were not then sufficiently complete, because they formed only a part of a more important work, intended to establish the effect of affinity in photography in general. Nevertheless, this part has attracted much attention and contradiction. For this reason I have been induced to repeat and complete my researches. MM. Girard and Spiller, especially, have thrown doubts on my assertion that

* Read at a meeting of the South London Photographic Society, May 14, 1863.

photographic papers, exposed for a long time to the light, toned with gold and fixed, contain only gold. My researches persuade me that it is a certain fact, and I have found that it is not impossible to establish the presence of minimum quantities of silver in the ashes of the photographic paper, even if they contain much gold.

I have examined the ashes of photographic papers which were treated with a weak solution of chloride of gold—the one *before* and the other *after* fixing; and also papers treated with a bath of *sel d'or*. The papers were well washed, the toning and fixing continued not less than half an hour, and sometimes an hour. After fixing, the papers were treated with a weak solution of ammonia.

The papers, having been prepared upon a dilute solution of chloride of ammonium, dried, and sensitized upon a solution of nitrate of silver (1 : 9), the paper was next day exposed to the light. I also, sometimes, employed paper prepared with arrowroot, without finding any perceptible difference. Of course, these experiments cannot be made with papers, the coatings of which combine chemically with the nitrate of silver, as albumenized paper for example. The paper, moreover, must be employed only quite fresh, because the silver combines with the fibre if the paper be sensitized some time in advance.

In my first essay I endeavoured to prove what I had said the previous year, that paper sensitized and exposed to light, if it remains very long in a dilute gold bath, loses almost entirely its metallic silver, and contains gold only—that the silver is formally replaced by the gold. The paper prepared as described above,—of the size of a normal plate—was exposed to light until its surface was completely bronzed. I afterwards carefully washed it, and cut it in two. I put one-half in a dilute solution of chloride of gold (1 : 2000). After leaving it in the solution for an hour, it was well washed, and fixed in a fresh solution of hyposulphite of soda, it was again washed in dilute ammonia, and, lastly, in plenty of distilled water. This paper, viewed by transmitted light, was quite clear, and of a fine violet-blue colour: its surface had a very fine velvety appearance. It is easy to perceive the silver in a toned and fixed proof, by viewing it by transmitted light. The silver is brown, the gold is blue.

The other portion of the paper was immediately fixed in hyposulphite of soda, and washed.

M. Professor Reichard, of the University of Jena, a chemist well known by his excellent analytical works, had the kindness to examine the two portions of paper. Each piece was burned in the flame of a spirit-lamp, and the ashes were boiled in a platinum crucible with nitric acid.

The nitric solution of the ashes diluted with a little water gave no remarkable turbidity with hydrochloric acid. After dissolving the residue of gold in *aqua regia* a slight black residue remained: chloride of silver could not be extracted from it by treating it with ammonia. The solution of gold was quite clear. Thus it was proved that there was no remarkable trace of silver in this paper toned with gold. The nitric solution of the ashes of the other half of the same paper which had not been toned with gold, gave a strong precipitate of chloride of silver with hydrochloric acid. Where then was the silver in the first portion of paper, if we suppose with some chemists that the gold is precipitated upon the silver without the latter being changed?

This experiment with the paper toned with gold was repeated three times. Once only was the nitric solution of the ashes made a little turbid upon the addition of hydrochloric acid. But even if it were possible to find traces of silver in small quantities it would not be in proportion with the quantity of metal contained in the proof not toned; consequently the metallic silver is changed in the gold bath into chloride of silver. The following experiment proved that view. A sheet of paper prepared and exposed to light, as before, was fixed and afterwards toned. It assumed the same blue tone as the paper toned before fixing, but it contained much silver, or rather chloride of silver. This is per-

haps one reason why proofs toned after fixing have a colour so little agreeable to the sight, that this method has long since been abandoned.

Now I have never pretended to assert that photography can, with every known gold bath, change its silver proofs into gold proofs, but only sought to discover if the silver reduced upon the paper acts upon the solution of pure chloride of gold in the same manner as metallic silver, and if this latter metal separates itself by its greater affinity for chlorine; I have also examined a bath of *sel d'or* from this point of view, and I have found that in this case the change, that is to say, the substitution of the silver by gold is made only partially.

In the course of my researches I have found that it is not difficult to prove the presence of minimum quantities of silver along with large quantities of gold, because in this case they are not alloys, but only mechanical mixtures of gold and silver in a state of fine division. Every trace of silver which has not been dissolved by nitric acid shows itself during the solution of the gold in *aqua regia*; it may be extracted from the black washed residues by the aid of ammonia, and precipitated by hydrochloric acid. As concentrated *aqua regia*, especially if it be heated, dissolves a little chloride of silver, the mixture of acids must be slightly diluted.—*Le Moniteur de la Photographie*.

COPYRIGHT IN PHOTOGRAPHS.

REPORT OF A COMMITTEE APPOINTED BY THE EDINBURGH PHOTOGRAPHIC SOCIETY.

A COMMITTEE was recently appointed by the Edinburgh Photographic Society to report upon the provisions and construction of the new Copyright Act, in relation to photography. In order to raise the points of most importance, a special meeting of practical photographers was called, who were asked to submit such questions as might appear desirable. The report is framed as answers to the questions. We reproduce the principal portion of the report from the *British Journal*, with the exception of a portion of it which was extracted from the PHOTOGRAPHIC NEWS ALMANAC. We also append one or two comments, in passing, on the report, which appear to us to be necessary.

QUERY I.

Whose is the Property of the Negative of a Photograph made for any one without Special Agreement as to the Proprietorship of the Negative?

The contract, in the case supposed, is for the execution merely of so many completed photographic copies of the work ordered, and the photographer in executing the order requires to produce a negative, about which no special agreement has been made.

The Committee think it clear that the negative does not belong to the customer, without special agreement to that effect. It must remain in the possession of the photographer. But his right will be only a limited or qualified right of property, and he cannot use the negative for any purpose, or in any way other than his customer may permit; for such use of the negative would be a violation of an implied contract with his client, that the work ordered should be produced for him alone, and for his purposes only.

QUERY II.

Is Registration Necessary to give the Copyright to the Person Ordering the Negative?

By the first section of the statute the person ordering the painting, drawing, or photograph, is entitled to the copyright thereof, provided they shall be made or executed for a good or valuable consideration. And by the fourth section it is enacted that no proprietor of any copyright shall be entitled to the benefit of the Act until registration, and no action shall be sustainable, nor any penalty recoverable, in respect of anything done before registration.

The Committee feel that this query involves a point of con-

siderable difficulty; for the first section of the statute vests the sole and exclusive right of copying and multiplying, *inter alia*, the photograph and the negative thereof in the author for the term of his natural life, and for seven years after his death, or in the person for or on whose behalf the negative of a photograph may have been made or executed. Now, when an unregistered work has been pirated, it may be contended that the proprietor of the copyright is entitled to vindicate his right; for the fourth section, which requires registration, speaks of the proprietorship of copyright as a fact apparently anterior to the registration which it requires. The Committee do not give any certain opinion on this subject, but submit that it ought not to be taken for granted that our courts of law might not sustain an action for damages for the piracy of unregistered copyright.

Much light may be gathered on the question from the state of the law of piracy of unregistered books. No failure in making the entry at Stationers' Hall, required by the statute, affects in any manner the copyright of books, but only subjects the person making default to the penalty under the Act. It is true that this provision is specially contained in the statute; but it is important to state that, prior to the statute, the Court of King's Bench unanimously held that an action for damages might be maintained for pirating a work before the expiration of twenty-eight years from first publication, although the work was not entered at Stationers' Hall, and although it was first published without the name of the author affixed. (Beckford v. Hood, 7, T. R., 620). And in a prior case (Tonson v. Collins, 1 Blackstone's Reports, 330), Lord Mansfield said—that it had always been helden that the entry in Stationers' Hall was only necessary to enable the party to bring his action for the penalty, but that the property was given absolutely to the author, at least during the term. It is to be observed, however, that the statute requiring the registration of books imposes the obligation of registration in Stationers' Hall as a duty, for failure of which penalty is paid; whereas, the statute conferring copyright on photography appears to regard registration as a privilege of the author or proprietor. The Committee accordingly incline to the view that registration is necessary to give validity to the copyright of a painting, drawing, or photograph.

[The committee, in discussing this question, seem to have overlooked the final sentence in the 4th section of the Act, which runs thus:—"And no proprietor of any such copyright shall be entitled to the benefit of this Act until such registration, and no action shall be sustainable, nor any penalty be recoverable, in respect of anything done before registration."]

QUERY III.

Has the Photographer a Right at Common Law to make any use of an Unregistered Negative?

This question seems to have been already answered under the first query. If our observations there are correct, the photographer has only a limited right of property in the negative, which does not permit him to make any use of it inconsistent with the purposes and wishes of the person for whom it was executed.

QUERY IV.

Suppose the Photographer Registers a Negative without the Knowledge of the Employer, would he be Entitled to the Copyright?

The photographer who registers a negative without the knowledge of the employer has no title to the copyright, and is not proprietor thereof under the statute; for, under the provisions of the first section of the statute, he does not retain the copyright, except under a written agreement with the employer.

QUERY V.

If a Registered Photograph be not Marked as Registered, is there a Penalty for Infringement?

The statute does not require any mark to be impressed upon a registered photograph. It is the fact of registration in terms of the statute that secures the right of property, and therefore the penalties may be incurred though there be no mark impressed on the photograph.

QUERY VI.

If a Negative be Unregistered, and Prints from it Published, may the Work be Copied and Reproduced?

The principle of this question has been discussed in the obser-

vations under Query II., in which it has been shown that it may be contended that a right of property may exist without registration. But so far as the scope of the present statute may be held to determine the point, the Committee think that this query should be answered in the affirmative, provided that no name, initials, or monogram be affixed to the copy. The existence of these upon the photograph is sufficient to bring the copier within the penalties of fraudulent productions and sales of the 7th section of the statute.

[See our remarks on Query II. The 7th section only prohibits the fraudulent copying of name, monogram, or initials.]

QUERY VII.

May a Photographer Copy and Produce for Sale a Proof before Letters of any Engraving?

Two important general questions occur under this query. The first is:—Do the engraving statutes protect engravings which do not contain the name of the proprietor and the date of the publication engraved on each plate and printed on every print?

The second question is:—Assuming that these statutes do protect such engraving, does the copying of an engraving by the art of photography come within their intention?

As to the first point. The first statute protecting engravings is the 8th Geo. II., cap. 13, entitled an "Act for Encouragement of the Arts of Designing, Engraving, and Etching Historical and other Prints," which recites that divers persons have, by their own genius, invented and engraved sets of historical and other prints, in hopes to have reaped the sole benefit of their labours, and that printsellers and other persons have of late frequently taken the liberty of copying, engraving, and publishing base copies of such works and prints to the very great prejudice and detriment of the inventors and proprietors thereof. For remedy thereof, and for preventing such practices for the future, the Act vests in the inventor and engraver the sole right and liberty of printing and reprinting the same for fourteen years, to commence from the day of the first publishing thereof; the date to be engraved, with the name of the proprietor on each plate, and printed on every print. It is the latter words which give rise to the question now under discussion.

The next Act is the 7th George III., cap. 38, and is an amending statute of the former Act. It is observable that this Act does not expressly require the name of the proprietor and the date of publication to be engraved on the print, but it seems probable, as it is merely an amending Act, that the provisions of the previous statute (8th George II.) in that respect should be considered as included in the latter. Now it appears that there is a difference of opinion in the authorities as to the true construction of the statute—some holding that the date and name are not essential, others that they are. In a case in 1792 this contrariety of opinion comes out, but the case referred to was not decided on the point in question. At a subsequent period, Lord Ellenborough said:—"Although the plaintiff's name is not engraved upon the prints, if there has been a piracy I think the plaintiff is entitled to a verdict. The interest being vested, the common law gives the remedy." In a subsequent case, however, the Court of Common Pleas held both date and name to be essential to make the copyright of an engraving valid.—*Newton v. Cowie*, May, 1827, 4 Bingham, 234.

This difference of judgment may well make the Committee hesitate to give any opinion of their own; but, so far as they can venture to do so, they think the date and name to be essential, and that however contrary it may be to the principles of equity to infringe the rights of another engraver, the law will not prevent the piracy or inflict penalties on the infringer when the date and name do not appear on an actually published engraving.

As to the second question, the art of photography is so recent, and of a character so different from any former mode of copying and multiplying the work of the engraver, that it is not surprising that a judge presiding at a late trial by jury ordered the point to be reserved for after discussion. The Committee, however, observe that the words of the statute are very general. In addition to the special words, "engrave, etch, or work," there occur these words, "or in any other manner copy." These are so general that, though the Act was passed more than a hundred years ago, as it is still in active operation it must apply to the changing forms of art and the advances of science. Yet it must not be forgotten that if the engraver may

pirate an engraving which does not contain the date of publication and the name of the proprietor, much more will the photographer who prints off his copies from a proof before letters be free from any penalty.

[The point raised in the second question here has since been decided to the effect that photographic copies are prohibited by the Act.]

QUERY VIII.

Was there, prior to the recent Act, any Copyright in any Painting, Photograph, or Drawing? And are Paintings and Photographs Made or Executed prior to the Act in any way now Protected?

The Committee are of opinion that there was no copyright in any painting, photograph, or drawing prior to the recent Act. Its preamble so states the law. The Lord Chancellor, in moving the second reading of the bill in the House of Lords, while he paid a well merited compliment to the position and the labours of artists, stated that he could see no distinction between paintings and literary productions; that if the one was entitled to be considered property the other was also. Of course there is a right of property in these works so long as they are unsold or unpublished; but the distinction between the two things must be always kept in view.

In like manner, paintings and photographs sold or disposed of before the commencement of the recent Act are not protected by statute in any way. But though made or executed before the commencement of the statute, if they were not sold or disposed of prior to its date, they are protected.

QUERY IX.

Is Attendance by the Proprietor or his Agent at Registration necessary?

The statute does not expressly require that there should be personal attendance; but it is a regulation which the registrar may be entitled to make. Photographers scattered throughout the country are thus obliged to employ an agent in London to register their photographs.

[The necessity of a cash payment, the registrar declining to receive stamps, &c., and the various verbal explanations which arise, render some personal attendance necessary, and this has induced our publisher to undertake the necessary agency].

QUERY X.

May an Engraving be Photographed Simply for the Purpose of Producing Transparencies, and not for Sale?

A very nice question arises whether the statutes have given any remedy in the circumstances stated in this query. The statute which hits against the practice—if it does so at all—is the 17th Geo. III., cap. 57, which enacted that if any engraver, printseller, or other person shall engrave, etch, work, or otherwise or in any other manner copy in the whole, or in part by varying, adding to, or diminishing from the main design, or shall print for sale, or shall publish, sell, or otherwise dispose of, any copy or copies of any print whatsoever, such proprietor may, by action upon the case, recover such damages as a jury shall give or assess.

Part of the above statute, it may be contended, seems to stand disjunctively in the context, and to create a separate offence from that of printing for sale, or selling, which is prohibited in the clause immediately following. If so, then the mere copying of a print gives the proprietor a right of action without any sale, and he may show his damages to have accrued from exhibition, or from injury to his reputation, or interception of his profits. On the other hand it may be contended that the statute does not apply to a case where there is no intention to print, publish, or sell, but only to exhibit in a certain manner; that exhibiting for amusement is in no way analogous to selling a copy of a print; and that the transparency exhibited being in different materials and of different dimensions from the original print, makes a case which the statute does not contemplate. A judgment of Vice-Chancellor Shadwell supports the latter view. But the Committee do not consider the question finally determined by the opinion of that Judge, and do not wish to express a certain opinion upon this nice question; but, having stated both sides of it, leave it for the consideration of the individual members of the Society.

[The principle here supposed, namely, that *sale for profit*

constitutes the gravamen of the offence, is negated by a decision, *Novello v. Ludlow* (12 C. B. 177), which regards *gratuitous* distribution of copies of a copyright work as an infringement.]

QUERY XI.

May One who Photographs the Portrait of Another without his Knowledge Publish such Photograph?

This question does not involve any point of importance. It appears to the Committee that it is always a question of circumstance whether it may be done with impunity or not. Suppose a landscape be taken while there stands in some part of it an individual of fame or notoriety; he surely could not object to appearing in the scene, for his presence there was a mere accident, or the artist meant nothing but to do him honour. The opposite doctrine would exclude the photographer from taking a view of any public ceremony or historical event. On the other hand, if the object be to hold up some one to ridicule, or to represent some one to his disadvantage, the photographer might be interdicted, or damages obtained from him. The head of the famous Mr. Spurgeon upon the body of the gorilla was probably considered by that gentleman himself, his friends, and the public, as a good joke; but a satirical representation of Mr. Spurgeon, meant to injure him, to cast doubts upon the sincerity of his religious profession, or otherwise affect his efficiency as a clergyman, would undoubtedly be illegal and improper.

Although criminals be photographed against their will or without their knowledge, and copies of their portraits circulated among the police of the country, they can have no right to object to such a proper use of their portraits as enables the authorities to detect crime; for every course that may be necessary in the judgment of the officials responsible for the detection of crime would be justified, on the same principle that no claim of damages lies against those at the instance of one accused of crime and afterwards found innocent.

The Committee cannot conclude without expressing their regret that the Statute has not been framed with such perspicuity as it might have been, and that doubts as to its interpretation on some points may be entertained. This arises from the fact that the registration clause in the Bill which was first read in Parliament was framed quite differently from the mode in which it now appears in the Act of Parliament. The Bill underwent many modifications in its clauses while passing through both Houses, and hence arises the difficulty of construction. The Committee, however, have been informed that there is a prospect of another Photographic Bill this session of Parliament, promoted by artists and engravers, which, it is hoped, will put an end to many vexed and doubtful questions.

[Signed.]

ANDREW MUIR, Chairman.

MEMORANDUM OF THE SALE OF A NEGATIVE PHOTOGRAPH, RESERVING THE COPYRIGHT TO THE PHOTOGRAPHER.

Stamp, 6d.

A. B., Photographer, having sold and disposed of the negative of a photograph [here describe it] made and executed by him, to C. D., it is hereby expressly agreed upon that the copyright thereof is retained by and reserved to the said A. B.

This memorandum is made in terms of the Act 25 and 26 Vict., cap. 68, and signed by the said C. D., at _____, the day of _____, 186 .

A. B., Photographer, having, for a good consideration, made and executed for and on behalf of C. D., the negative of a photograph, of [here describe it]—it is hereby expressly agreed upon that the copyright thereof is retained by, and reserved to, the said A. B.

This memorandum is made in terms of the Act 25 and 26 Vict., cap. 68, and signed by the said C. D., at _____, the day of _____, 186 .

MEMORANDUM OF ASSIGNMENT OF COPYRIGHT.

Stamp, 6d.

I, A. B., proprietor of the negative of a photograph of [here describe it]—and registered in my name as proprietor thereof, in the Stationers' Hall, on the day of _____, 186 , in terms of the Act 25 and 26 Vict., cap. 68, hereby assign to C. D. the said negative photograph and copyright thereof.

This memorandum of assignment, made in terms of the above Act, and signed at _____, the _____ day of _____, 186 _____.

I, A. B., Photographer, having, for a good consideration, made and executed for and on behalf of C. D. the negative of a photograph of [here describe it]—it is hereby expressly agreed upon, that the copyright thereof is to be retained by and reserved to the said C. D.

This memorandum is made in terms of the Act 25 and 26 Vict., cap. 68, by me, the said A. B., and signed at _____, the _____ day of _____, 186 _____.

MEMORANDUM OF SALE OF NEGATIVE OF PHOTOGRAPH,
RESERVING THE COPYRIGHT TO THE VENDEE.

Stamp, 6d. Vict. 23, cap. 15.

I, A. B., Photographer, having sold and disposed of to C. D. the negative of a photograph of [here describe it]—made and executed by me, it is hereby expressly agreed upon that the copyright thereof is to be retained by and reserved to the said C. D.

This memorandum of sale is made by me, the said A. B., in terms of the Act 25 and 26 Vict., cap. 68, and signed at _____, the _____ day of _____, 186 _____.

NOTES ON THE COLLODIO-ALBUMEN PROCESS.

BY W. D. CLARK.*

AFTER stating that the negatives of some charming views of Edinburgh, &c., which we have before had occasion to praise in these pages, were all by the collodio-albumen process, as described by Mr. Mudd, Mr. Clark proceeds:—

Good negatives may be got by this process with a very wide range of exposure, as the development may be varied to meet the greater or less degree of light; but it is a great comfort to have the plate well exposed, and it is better to get a plate over-exposed rather than under-exposed.

My Edinburgh views are 9 inches by 11, a quarter of a sheet of paper. For this size, with a fair light, ten minutes is a good average exposure for buildings, and fifteen to twenty minutes for subjects composed chiefly of trees. Many members of your Society practise the wax paper process: a good rule to begin with would be to give half the exposure required for wax paper.

I dare say you will remember how pleased I was when you first showed me your camera, copied from Mr. Kinnear's, and how you kindly undertook to get one made for me. As soon as I received it, I sent it to Mr. Mudd's rooms, so that it might be seen. He and other friends in this district adopted it, and we have all used that form ever since in our excursions, and feel indebted to that gentleman for having given us so handy an instrument. When in the border country, last autumn, with a friend, who is an admirable photographer, he remarked that he never put up his camera without being struck with the ingenuity displayed in its contrivance.

I fancied that a light lens might be best suited for so light a camera, and so adopted Ross's orthographic, which had just then been introduced. I used it alone for two seasons, and found, in addition to the advantage of straight marginal lines, that a pretty large stop could be used with it in dark weather, without much loss of definition. Many of my Edinburgh views were done with this lens; but as it does not give quite the same sharpness for ordinary landscape work as the old single lens, I added to the camera one of the Lerebour's lenses with rather a sharp focus, that Mr. Mudd got made with the special view of being used with Mr. Kinnear's camera.

I am now having one of Dallmeyer's 8 × 10 triplet lenses fitted to the same camera, so as to get the advantage, when desirable, of the wide angle of view this lens includes.

As each kind of lens has special advantages, I think it of great importance to have more than one lens fitted to the same camera when aiming at first-rate work.

Every one knows the distortion got by tilting up the camera in architectural subjects. This is very decided in my print of the door of Holyrood Abbey. I think a very simple way of getting rid of this defect with a Kinnear's camera is to have the front part that carries the lens so arranged that it can be turned back and fixed at any angle that may be necessary. By this means the camera is always kept, as it should be, hori-

zontal, and only the lens is turned up towards the subject.* This is much simpler than tilting the camera up and then adjusting a swinging back with one's head beneath the focusing-cloth. The tilting of the camera is always an awkward operation. Another advantage of this method of turning back the lens is, that when you have very near and distant objects in your subject, you can get both well in focus. A 15 × 12 camera I have, made by Mr. Nelson of Edinburgh, has this plan carried out very ingeniously; and I find that with a Petzval lens I get the flowers in my garden and the hills three or four miles distant all quite perfect in focus at the same time.

Last summer I worked a good deal with Dallmeyer's small triplet lens, fitted to a folding camera 5 × 7 inches. This is a most convenient instrument for an amateur working with dry plates. The pictures it gives are very beautiful; and eight plates may be carried in four double slides with ease, in a leather case that also contains the camera. I carried this little apparatus over some of the roughest ground in the Highlands, without being incommoded with it. I shall send you a few specimens along with this, to show what can be done with this portable little instrument. Mr. Dallmeyer tells me that my negatives will bear enlarging to 15 × by 12 inches; and I intend to attempt this with a lens he is now making.

[Mr. Clark, after describing the details of exposure, &c., of several of his pictures, proceeds to make some remarks upon the critics who have at different times commented on his pictures, in which he displays an amusingly thin-skinned irritability. A contemporary had, for instance, praised the photography, but condemned the point of view, and Mr. Clark crushes him by saying that he had had the assistance of two of Scotland's best landscape painters in selecting the point of view; but he forgets that even that might not prevent it from being bad. He then tells a story, which sounds very like a *canard*, illustrating the comical ignorance of some critic who had gone from London to Manchester to report upon an exhibition, but who absolutely did not know of the existence of a Royal Scottish Academy! Mr. Clark's pictures are for the most part good, and he appears a shrewd and intelligent man, although he talks some nonsense about the critics. But he and all exhibitors should remember that an adverse criticism cannot make a good picture a bad one; and that if the public examine a picture condemned by the critics and find it good, they cease to trust that critic, so that incapable or dishonest criticism rarely either serves any journal or damages any artist. Criticism cannot always be perfect, but we believe it is for the most part both honest and just.]

I have practised three modes of development. So far as I can judge, they all give equally good results. I first use gallic acid, just as for wax paper. For this method it is desirable that the plate should be well exposed—if it is not so, the development is very tedious. A convenient way of conducting this is to have a saturated solution of gallic acid in alcohol. Pour as much of this into a quantity of water as will make it taste distinctly bitter. Put your exposed plate into a flat glass dish; add a very little nitrate of silver, without any acid, to your solution of gallic acid, and fairly cover your plate with this. If the exposure has been satisfactory, you will be able to see your subject pretty distinctly in about ten minutes, and the process will be finished in from half an hour to an hour. I like to develop a picture slowly, for by that means you get a great deal of detail that you will lose if you blacken the plate quickly by using nitrate of silver liberally to begin with. It should be remembered that it is the *gallic acid* that develops. The silver merely *blackens* what has been developed. For this reason it is proper to add so little silver at first, that the picture comes up of a *brown* colour; and when *all* the detail is fairly out in *this* way, add more nitrate of silver, and the plate will rapidly blacken without becoming dirty, or deposit forming in the solution. No acid is necessary in this process.

If the plate is under-exposed, the development will be very slow. In this case, it is better to wash the plate and develop by a more energetic method.

I used generally to develop from four to six plates at the same time, in as many dishes. They require very little attention—only an occasional shake to prevent the development on the sky

* We suggested an arrangement for this purpose to Mr. Meagher some years ago, who carried it out in a camera for use, and manufactures them so to order.—Ed.

* Condensed from a Communication addressed to the Photographic Society of Scotland, and read April 14th.

assuming a crystalline form, somewhat like water when it is freezing.

A convenient and cleanly method of raising the plate from the glass dish, for the purpose of noticing how the process is going on, is with a bent silver wire.

It is during development that the great advantage of collodio-albumen over other dry processes is found. The surface of the plate is a *hard* one. Whenever any markings or stains are noticed, stop the development, pour plenty of water over the plate, and rub it till clean with a tuft of fine cotton-wool; then proceed with the development as before. In rubbing the plate, a circular motion is best. It is astonishing the amount of friction a plate properly prepared will bear. Duck eggs give a particularly hard film. Of course no sand or grit must be in the cotton or water, or the plate will be scratched. The fingernail will also scratch, but that is easily avoided.

To develop with pyrogallic acid, place the plate on a stand and moisten it with water. I have used various kinds of stands, but like none so much as the large glass goblets used in Scotland for making toddy. Placed in a flat porcelain dish, it is easily made level by packing the dish beneath with bits of paper or cloth. A round stand, such as this, is more convenient to tilt the plate than from a triangular one. Mr. Mudd has a round stand, manufactured of brass, with a heavy foot. It is very good and convenient; but I prefer the toddy-tumbler, as it can be so easily and perfectly cleaned. All metal stands, too, have the objection of decomposing the developer, if it comes in contact with it, when it contains nitrate of silver. Well, when the plate is moistened, pour the water off; take a solution of pyrogallic acid (say, of two grains per ounce), add a few drops of a rather weak solution of nitrate of silver (say, ten grains per ounce), with one-third or one-half of its weight of citric acid added. Pour this on and off the plate till the details of the picture are well out—of a feeble brownish colour; then add more of the silver solution to the developer, and the plate will blacken rapidly. The developer will probably get dirty before the picture is out; if so, throw it away. Wash the plate *well* with plenty of water and a tuft of clean cotton. Mix more of the developer in a clean glass, and proceed as before. Do not push this process too rapidly, if you want a delicate negative full of detail. Fifteen to twenty minutes are a fair time.

A very elegant modification of this process was introduced by Mr. Wardley, of Mr. Mudd's establishment. I think it the best at present known. He found that when pyrogallic acid was used quite alone, and other acids kept away, the plate developed easily and clearly. The plate is afterwards blackened by silver.

To work this process, take a solution of pyrogallic acid, of almost any strength—say from two to twenty grains per ounce. After the plate is moistened with water as before, pour on and off with this solution till the subject is pretty fairly out. The colour of the negative will be very faint and feeble. It is then blackened up by adding to the same pyrogallic acid some nitrate of silver containing citric acid (say half its weight of acid), and pouring on and off till the desired depth is obtained.

This process can be made to work very rapidly by using the water hot—say, from 120° to 140° Fahr. The plate may be brought up to this temperature by pouring plenty of water over it, or, as I generally do, by placing it over a sand-bath. The warm solution of pyrogallic acid must be spread over the plate very rapidly, as the picture starts out almost instantly. This is the proper process for plates that have had short exposures. All the little (5×7) prints I send, with exposures of one minute or under, have been developed in this way—that of St. Mary's Loch, for instance—nothing can be done more perfect than the detail of the dark pine-tree in the foreground; and in the negative the detail is perfectly given of trees and farm-house on the margin of the lake, with their reflections in the water; but unfortunately such distant objects are greatly lost in a paper print; they all show till the print enters the hyposulphite. As you well know, such delicate gradations suffer much in the fixing. I think this little print shows what an admirable lens Dallmeyer's triplet is.

One of the most difficult things in photography is to know how far to carry the development. The difficulty is increased by the variability of the light in the operating-room. Looking through the negative, its density appears greater or less according to the strength of the light outside. Of course, the beauty of the print depends on the negative having the right density. The best plan is that proposed first by Mr. Mudd, of

having a good negative in the room beside you to compare with. In collodio-albumen the development can be carried further after fixing, provided all the hyposulphite has been *completely* washed off the plate; and if a negative be too dense, it can easily be reduced by placing it in a dish with a very weak solution of iodine in iodide of potassium. Watch the plate carefully till you think a sufficient quantity of the silver has been converted into iodide of silver. Wash, then dissolve out the iodide by means of hyposulphite of soda, and wash again.

In fixing, never employ cyanide of potassium, as its strong alkaline reaction destroys the albumen. Use hyposulphite of soda, from 4 to 6 oz. per pint, and add sufficient acid (say, muriatic or acetic) to make the solution distinctly acid to test-paper.

Mr. Sutton has said that painting out skies is one of the immoralities of photography. If this be true, I am a most immoral photographer; for I think a negative not worth much if it does not require the sky painting out, either wholly or in part. If the sky be deep enough to resist the light, it is either over-developed or it has not been sufficiently exposed; and it will print hard—black and white, and without the delicate gradations that are the chief charms of a good photographic landscape.

I do not think we will ever be able, in ordinary landscape work, to get clouds and the landscape at the same time; for if the exposure be such as to get the clouds perfect, the landscape is greatly under-exposed. I have seen some pretty fair attempts, but they were only tolerable, done by a kind of compromise—the exposure too long to get the clouds perfectly, and too short to get satisfactory detail in the landscape. The sea-shore views are a kind of exception, because there you have only sea and sky, and the difference of light on the two is much less than in ordinary landscape. Of these, the pictures on glass by Mr. Breeze are probably the best; but in them, where there is a bit of rock, or boat, or other solid matter, it is under-exposed; only the clouds and sea are perfectly given.

The absence of clouds is one of the greatest defects in landscape photography; but here composition pictures are quite legitimate—one negative for the landscape and another for the sky. This certainly increases the trouble of printing considerably; but I fear it is the only way to overcome the difficulty.

If we look at the engravings from the works of an able artist, such as Turner, and suppose the clouds removed and replaced by a simple wash of grey, we at once see that the beauty of the prints would be destroyed. In like manner, I think if we can add appropriate clouds to our photographic landscapes, we shall greatly increase their interest.

I send you two or three small examples to illustrate this. From each negative there is a print, with and without clouds. The clouds are printed in from two negatives, taken at the coast by my friend Mr. Sidebotham, of The Strines. You will notice how much additional character and expression is given by the clouds, and how much they increase the idea of space. This is perhaps especially the case with the view of Smalholm Tower. The sky has been printed so as to give a wild look to it, in keeping with the solitary rootless tower reflected in the little loch. I must mention that the negative of the landscape in this case is also by Mr. Sidebotham, taken during a little excursion we made together into the Border country last autumn.

There is an advantage contingent on printing the sky from a separate negative. A photographer has often to wait a considerable time for suitable weather to take his views; but if, in addition, he had to wait for clouds that would form an agreeable composition with his subject, the difficulty of doing much would be greatly increased.

Proceedings of Societies.

SOUTH LONDON PHOTOGRAPHIC SOCIETY.

THE usual monthly meeting of this society was held in the City of London College, on the evening of Thursday, May 14th, the Rev. F. F. Statham, M.A., F.G.S., in the Chair.

The minutes of a previous meeting were read and confirmed. Mr. MARTIN exhibited some brilliant prints on resinized paper, produced by Messrs. Horne and Thornthwaite, with decolourised resins. A plan had also been adopted of keeping

the solution on the surface, and so producing with the dead surface a brilliancy almost equalling that of prints on albumenized paper. He was not in a position to communicate the details of the method employed to the meeting.

Mr. HARMAN exhibited some fine card portraits on enamelled paper.

Mr. HARMER then read a paper "On Double or Fancy Printing," (see p. 243) in the course of which he illustrated the mode of manipulating he employed in the various stages of the operations described, and also the kinds of masks employed and the mode of preparing them. He also referred to the recent allusion of our American correspondent to some moonlight scenes produced in Philadelphia by composition printing, and said that he had tried similar effects some time ago, and now produced some negatives consisting of clouds and moon simply drawn with a black lead pencil.

Mr. A. H. WALL said that whilst looking at Mr. Harmer's masks he had been struck with the fact that the plan adopted might possibly be made to have a wide and useful application in the industrial ornamental arts, in producing designs now obtained by the more expensive process of engraving. As to the use of a method of introducing ornamental borders to photographs he thought it was a dangerous suggestion, and he was always sorry to see a power put into the hands of photographers which was so liable to abuse, and with which they were so liable to make a mess. He had laughed heartily at the American notion of a white paper moon. Cloud negatives to produce the effect referred to ought to be carefully prepared by artists from photographic studies; but he could not help feeling that some of Mr. Harmer's suggestions put a dangerous power into many hands who would abuse it.

Mr. G. WHARTON SIMPSON remarked that in all things a power was, in proportion to its capability of good, effective in bad hands for evil. He thought, however, it was scarcely wise or desirable to deprecate the use of Mr. Harmer's method because it was capable of abuse.

Mr. WALL did not wish to do that. He had been going to add that the method which appeared undoubtedly to have been originated by Mr. Harmer was accredited in various portions of the newspaper press to Messrs. Dickenson who obtained considerable praise for the artistic effect produced.

The CHAIRMAN thought it a pity that the old adage, *palman qui meruit ferat*, should be forgotten in such matters; Mr. Harmer was certainly deserving of much credit for the ingenuity shown, and the admirable results obtainable with a comparatively small amount of labour.

After some further conversation and examination of specimens,

Mr. HART exhibited a printing frame which he had devised some years ago for facilitating double printing, of which we shall give a detailed description in our next.

Mr. G. WALLIS, the inventor and patentee of the system of autotypography, recently described in our pages, and the possible combination of photography with which we suggested, attended this meeting for the purpose of exhibiting some of his productions, explaining his views of the photographic bearing of his invention, and hearing any suggestions on the subject. He said that, as an artist, he had long felt the want of some method by which an artist could himself execute a drawing to be multiplied by the printing press, without the intervention or translation of another mind and hand, as was now necessary in engraving. He then entered into a brief history and description of his invention, all details of which will be found in his paper in our pages a few weeks ago. He then proceeded to state what the conditions were, which in photography it would be necessary to secure, in order to make it available in connection with his process. An image in some definite relief, however small the amount, in a hard concrete substance on a textureless surface was necessary. The bed of his machine was of glass, and it was possible that it might be used to receive the image. Or it might be produced on gelatine paper, prepared with collodion varnish, to render it waterproof. The amount and kind of relief must be such as would produce in the intaglio, produced on the surface of the metal plate, sufficient holding power for the ink, so that it would not wipe out. He scarcely hoped that it would be possible to produce an impression so perfect and complete by photography, that it would not require touching at the hand of the artist. But he thought if an impression could be produced, which should be 75 per cent. photography, and 25 per cent. the touch of the skilled artist, something very valuable both in truth of result and in economies would be gained.

The great advantage of his method was found in the fact, that, when a photographic impression as perfect as possible was obtained, it might be finished by the artist's pencil with the proper ink very easily, and then a complete plate produced by his machine. This was just the point in which the processes of Pretsch and others had failed: any re-touching their productions required must be done with the graver on the metal plate, which was much more difficult and costly than his method of working on the impression from which the plate was to be produced. He expected that photography would fail to give the deep forcible shadows which gave vigour to the result; he referred to those parts produced by what engravers called the deep digs. This, however, could be supplied by hand. He had already produced a plate from a photographic impression of an engraved plate, from one of Raphael's drawings, and he believed if those more skilled in the details of photography were to give the matter proper attention it would soon be done. Indeed, if he had time to devote to the matter, he thought he would be able to produce a photographic plate by his method in fourteen days from that time.

The CHAIRMAN, proposing a vote of thanks to Mr. Wallis for his interesting description of his beautiful process, asked him if he had tried to produce an impression from a Daguerreotype?

Mr. WALLIS said, "No;" but to clear the ground he might state what he had done. He had taken a mixture of starch, gum, bichromate of ammonia, and Paris white, with these he had coated paper in a dark place, and had then submitted this under a negative to the action of light. Those parts on which the light had not acted were, of course, soluble, and were easily washed away, whilst that on which light had acted was insoluble, and remained on the paper in relief, capable of giving an intaglio image on his plates. A difficulty in the way of using paper from the fact that its texture was reproduced, giving a grain. This might be dealt with by burnishing out the high lights, as in mezzotint engraving. If the photographic image could be produced on gelatine paper, it would then be in the same condition as his drawing.

Mr. SIMPSON explained, in reference to the question about the Daguerreotype plate, that it presented an image less in relief, perhaps, than any other kind of photograph, except ordinary prints. The ordinary collodion image, especially, when forced a little in intensifying, possessed a very palpable relief; but whether of the right kind for the application in question seemed uncertain. There were various other methods of obtaining the image in relief. Several very ingenious methods were described in a very elaborate specification of a patent by Mr. Joseph Lewis, of Dublin. Those interested in the subject might consult that specification with advantage, and if the methods there given were available here, their use might easily be made the subject of arrangement.

Mr. WALL thought the very great number of tones, and the delicate gradation of photographs, would be difficult to render in such a manner.

Mr. WALLIS said they were there to look at the difficulties, and, if possible, overcome them.

Mr. SIMPSON said he thought that Mr. Wall's objection was largely met by the former remark by Mr. Wallis, to the effect that perhaps 25 per cent. of artistic manipulation must be added to complete the 75 per cent., which had been obtained from the photograph. It was clearly true that as the gradations of a photograph were not like the conventional rendering of gradation obtained by hatching, stippling, lines, &c., a difficulty was interposed, as these methods seemed almost necessary in impressions to be printed. But a few touches of the artist upon the image already rendered by the photograph, might give very effective pictures.

Mr. WALL thought the process would, not render the more delicate gradations of photography.

Mr. WALLIS thought it would, and showed drawings in which touches of great delicacy were rendered, and to these might be added the forcible touches given by what Mr. Simpson had well called the conventional mode of rendering gradation.

A conversation on the subject followed in which Messrs. Wallis, Sebastian Davis, Wall, Harman, Simpson, and others took part.

Mr. MARTIN said he thought sufficient emphasis had not been laid on the introduction of oxides of manganese and tin to the ink to give hardness to the image.

Some conversation on this point followed, and on the use of some suitable metallic oxide in getting photographic images in relief, &c.

In answer to a question by Mr Simpson on the subject of the hardening of the plates, by the acrierage process, Mr. Wallis said when this was done, 2000 impressions might be produced easily from one of the plates.

In answer to a question as to the composition of the ink which gave the drawing in relief, Mr. Wallis stated it consisted of Indian red, rice starch, gum, oxide of tin, Paris white, and bichromate of ammonia.

Mr. SIMPSON observed that it was somewhat singular, that in a somewhat remote degree this was already a photographic process, as the action of light on bichromates, in combination with organic matter, was one of the conditions necessary, as it hardened and rendered insoluble the ink by which the drawings in relief were produced.

Mr. WALLIS said he had no hesitation in saying that without the knowledge of the properties of certain bodies introduced by photography, this process would have been impossible.

After some further conversation the subject was concluded.

Mr. SYDNEY SMYTH exhibited a parcel of very fine negatives produced by the intensifying process with iron and citric acid, recently described in the PHOTOGRAPHIC NEWS.

After some routine business in reference to the election of officers at the ensuing annual meeting,

The CHAIRMAN announced that it was hoped the two presentation prints, one a figure study, by Mr. Rejlander, and another a fine landscape, by Mr. Henry White, would be ready at the next meeting.

It was announced that at the next meeting Mr. Leake would read a paper on the intensifying of negatives, after which the proceedings terminated.

PHOTOGRAPHIC SOCIETY OF SCOTLAND.

THE Photographic Society of Scotland which twelve months ago seemed in danger of dying of inanition, resolving to meet once in two months instead of monthly as before, seems recently to have been unusually active and its proceedings very interesting. We find in the last number of its organ, the *Photographic Journal*, copious accounts of two meetings held in April and May respectively, from which we condense the following, and also reproduce the most interesting papers on another page.

An ordinary meeting was held April 14th, Mr. George Moir in the chair. After some routine proceedings the Honorary Secretary read the following.

REPORT OF THE PRIZE COMMITTEE.

THE Committee have endeavoured, to the best of their ability, to discharge the duty devolved on them, which they have found to be a difficult and delicate one.

They recommend that the prize for the best portrait or group be given to Mr. Robinson's, of Leamington, "Bringing Home the May."

At the same time, the Committee have some doubts whether any fair comparison can be instituted between such elaborate compositions and single figures or groups. They would, therefore suggest to the Society that in future the medal should be given for the best portrait or group taken direct by the camera at one operation.

Laying aside Mr. Robinson's picture, the Committee would have found great difficulty in deciding between the competing claims of Mr. Tunny, who contributes a beautiful portrait of a young gentleman, and some of the admirable small portraits of Mr. Rodgers, of St. Andrews.

In landscape photography, the Committee have found the merits of Mr. Maxwell Lyte's Pyrenean landscapes, and the charming English landscapes of Mr. Vernon Heath, so equal, though in different styles, that, as the only practical solution of the difficulty, they would recommend that a medal should be given to each; the "Lac d'Or" being selected as, on the whole, the best picture by Mr. Maxwell Lyte, and "Near Burnham, Bucks," as the best by Mr. Vernon Heath.

They would also beg leave to mention, as following close on the two names already mentioned, the contributions of Mr. Mudd, Mr. Annan, and Mr. S. Thompson.

For printing in carbon, the Committee would recommend that the medal be given to Mr. Pouncy, of Dorchester, for his view of "Melrose Abbey," in which, it appears to the Committee, he has overcome the difficulty of representing in carbon every variety of shade and tint exhibited in the original negative. At the same time the Committee trust that Mr. Pouncy will be stimulated by this award to perfect his most important discovery, and not rest satisfied till he is able to compete in

delicacy of tint and pureness of lights with prints produced by nitrate of silver, so as to make his process available either for landscapes or portraits.

In apparatus connected with photography, the Committee would desire to mention the beautiful cameras and lenses exhibited by Mr. Dallmeyer; but the only camera possessing peculiar merit is that by Mr. Meagher, the *binocular camera*, which comprises in itself all the best features of other cameras, and is suitable either for stereoscopic pictures, *cartes de visite*, portraits, or for views the whole size of the plate.* For this camera the Committee would recommend that Mr. Meagher receive a medal.

(Signed) 'GEORGE MOIR.

COSMO INNES.

T. B. JOHNSTON.

14th April, 1863.

The report met with the cordial approval of the Society. Some notes "On the Collodio-Albunum Process," by Mr. Clark, were then read, and illustrated by some fine photographs. After some other proceedings, the meeting terminated.

The annual meeting was held on May 12, Mr. C. G. H. Kinnear in the chair.

A paper "On Photography, as a Fine Art," by Mr. W. D. Clark was read; and also one "On the Curvature of the Image due to the Primary and Secondary Force of Oblique Pencils of Light, and on some other points in Photographic Optics," by Mr. R. H. Bow.

The silver medals of the society were then awarded as follows:—

For the best Portrait or Group.—Mr. H. P. Robinson, of Leamington.

For the two best Landscapes.—Mr. F. M. Lyte, Baguères de Bigorre, and Mr. Vernon Heath, London.

For Prints in Carbon.—Mr. John Pouncy, Dorchester.

For Photographic Apparatus.—Mr. P. Meagher, London.

The annual report was then read, from which it appeared that a balance remained in the hands of the treasurer amounting to £366 0s. 7d. It also announced that arrangements had been made with Mr. Vernon Heath, for a number of copies of his prize picture, "Near Burnham, Bucks," as a presentation print to the members.

The following gentlemen were then elected as officers for the ensuing year:—

President.—Sir David Brewster, K.H., F.R.S., &c., &c.

Vice President.—C. G. H. Kinnear; Horatio Ross.

Council.—Wm. Scott Elliot; Rev. D. T. K. Drummond; George Moir; James G. Tunny; Alex. Young Herries; J. Ramsay L'Amy; Major Bell; William Walker.

Honorary Treasurer.—H. G. Watson.

Honorary Secretary.—T. B. Johnston.

Honorary Auditor.—John Cay.

Correspondence.

FOREIGN SCIENCE.

[FROM OUR SPECIAL CORRESPONDENT.]

Paris, May 20th, 1863.

OUR sixth Photographic Exhibition opened its doors to the public on the 1st inst., although its arrangements were not fully completed, for no catalogue was ready, and new pictures are being added daily.

A very cursory inspection soon satisfies the spectator that Photographic art is in a rapidly progressive state. The immense diversity of subjects, and the extreme beauty of most of the pictures, is at first quite bewildering, and one cannot help pausing frequently, and asking, Can all this be photography, pure and simple?

Of portraits there are all sizes, from the miniature postage stamp and carte de visite, to the "enlarged" life size, each with its own peculiar and distinguishing excellencies. In fact, portraits predominate in this Exhibition, and in most cases excite strong interest, from the remarkable excellence of the pictures, even though the originals may be unknown. Foremost in this department of the art stands M. Adam

* This is the camera we designed for our own use two years ago, which was admirably carried out by Mr. Meagher, who has since manufactured it largely. See PHOTOGRAPHIC NEWS, p. 259, vol. v.—ED.

Salomon, whose productions are incomparable for vigour, brilliancy, and life. It is truly wonderful, and altogether inexplicable, how a photographer can so *create* his subjects, if I may so express it: how, if his art be so mechanical, as some maintain it is—how can this remarkable difference, in portraits especially, be attained. For, if the art were so very mechanical, all could and would attain to the marvellous results which M. Salomon wholly reserves to himself. There are some, however, who maintain that the portraits by this artist are elaborately re-touched, and their peculiar aspect would appear to warrant that assertion; if such be the fact, it would modify our admiration, but not detract from certain peculiar excellences. There are, however, many portraits by other artists which cannot lie open to this suspicion, and which serve by their intrinsic excellence to maintain the supremacy of this branch of the art. Angerer, of Vienna, exhibits a magnificent collection, and the works of M. Carjal are scarcely a whit less excellent, his portrait of Count Nieuerkerke is a triumph of photographic portraiture. The portraits contributed by M. Claudet have excellences peculiarly their own. M. Alophe and M. Thouvert also contribute some remarkably fine heads.

Among English exhibitors, the most prominent are Coloud Stuart Wortley and Mr. Robinsou; the former, by his magnificent marine views, in which Vesuvius in a state of eruption is most conspicuous; and the latter, by his large picture of "Bringing Home the May." This is regarded as the gem of the Exhibition.

The Exhibition is particularly rich in landscapes and fine architectural subjects. M. Cama's views in Egypt, from waxed-paper negative, which occupy a space of nearly seven square yards at the bottom of the room, have a most imposing effect. The pictures are remarkable both for their vigorous *chiaroscuro* and their delicate gradation of tone. The views in Spain, from negatives taken by the late Mr. Clifford, present us with many of the finest specimens of Arabic architecture extant. MM. Bisson Freres' Alpine views are, doubtless, familiar to you; they form a very prominent feature in this Exhibition. M. Nadar, who is equally at home in the clouds as under ground, exhibits some very interesting views taken in the Catacombs by the aid of the electric light.

The Viscount Aguado exhibits some interesting specimens of enlarged pictures, landscapes, and marine views. Of stereoscopic pictures there are but few, and those are for the most part the productions of MM. Ferrier and Soulier, who also exhibit some remarkable positives on glass.

Engraving by photography has arrived at a remarkable degree of perfection, especially in the hands of M. de la Blanchere and Baudvan. A series of seven portraits exhibited by them, whole-plate size, are truly surprising from their excellence in all artistic qualities, and they are, moreover, printed in carbon ink upon copper or steel plates. The enamel positives of M. Lafon de Carnassac have also acquired an extraordinary degree of delicacy during recent improvements. Most of the pictures are superior to those taken on paper, and are, moreover, of an imperishable nature.

Among the curiosities of this capital none is more interesting to the photographer than the establishment of MM. Delton and Co., styled the *Photographic hippique*, situated in the Avenue de l'Imperatrice, Champs Elysées. It is a charming spot, where a beautiful garden surrounds a spacious courtyard containing the accessories necessary to this kind of photography—stables, carriages, &c., a vast glass operating room, a charming greenhouse, splendid saloons furnished with magnificent albums containing specimens of portraits on horseback, &c., including most of the aristocracy of Europe. The ever active proprietor of this establishment fully aware of the necessity for novelty in sustaining in vogue, has recently patented a new kind of publicity by giving photographic representations of works of art, as well as of all kinds of mechanical and commercial productions, specimen cards, views of interiors of warehouses, mansions, houses, carriages for sale or to let, &c. This album thus

forms a most unique kind of advertising medium, and this may be regarded as one of the most ingenious and useful applications of photography to the ordinary business of life.

INSTANTANEOUS AND LANDSCAPE PHOTOGRAPHY.

DEAR SIR,—I omitted to state in my article on "Landscape and Instantaneous Photography," in the *NEWS* last week, that the effects of atmosphere are more *forcibly* given with my formula than with any other I have tried; I have always a decided objection to taking pictures when the wind is in the east, the fact of its being so, being plainly depicted in the resulting positives.

I also omitted to state that for interiors and very long exposures, I use Sutton's rapid dry collodion 20 ounces, Pouting's ordinary 10 ounces. I find the plate will keep after sensitizing full 15 to 20 minutes without deterioration. Trusting that these remarks may prove of assistance to amateurs and others, I remain, dear sir, yours truly,

W. H. WARNER.

IRON INTENSIFIERS.

SIR,—I was very pleased to see Mr. Blanchard's suggestion of an *iron* intensifier in No. 243 of the *PHOTOGRAPHIC NEWS*, and also your commendation of the same to your readers in your leader of the same number; for pyrogallic acid, although it is a very good intensifier, it is difficult to get pure; it is expensive, and its solution will not keep many days in warm weather. The fact too, of negatives intensified with iodine followed by pyro and silver (a very favourite method), being liable to darken gradually from exposure to sunlight, as proved by such good authorities, makes the introduction of a new intensifier the more important.

Without wishing to claim priority of invention in this, the credit or profit from which I do not care for, being only an amateur, I will lay before you a process very similar, but, I consider, superior, to Mr. Blanchard's, which I tried with success last season at Ventnor. If you approve of it you may give the photographic world through your columns the benefit of it; if not, consign this to your waste-paper basket.

With this long preamble here is my *modus operandi*. Collodion highly bromized; bath—neutral, or faintly acidified with nitric acid. After an exposure that most photographers would call *long*, I use this

Developer.

Protosulphate of iron	8 to 10 grains
Glacial acetic acid	30 minims
Alcohol	quant. suff.*
Distilled water	1 ounce.

When the details are well out this is tilted off, and without washing the plate, a second quantity of the *same* solution is applied as an *intensifier*, with the previous addition to it of a few drops of

Nitrate of silver	15 grains.
Citric acid	15 "
Distilled water...	1 ounce.

The desired intensity being obtained, if water be plentiful the negative is fixed with hypo and washed; but if that friend to the photographer, of every creed, be scarce, the plate is rinsed with one or two drachms of the precious liquid, flooded with glycerine, and carried home in one of Murray and Heath's "draining plate boxes," to be fixed at leisure.

This formula, founded on Major Russell's very excellent one for tannin plates, has, I think, great advantages, such as the use of the same solution as developer and intensifier, and having the same proportion of acetic acid and alcohol in each case the plate does not require any washing between the two operations; then the intensifying is slow and under control, and the deposit of silver very fine, giving beautiful delicacy in the negative.

* According to the age of the nit. silver bath.

I have deferred writing to you for two or three weeks hoping to get the leisure to try a few plates, by way of confirming my experiments of last autumn, but professional duties have so occupied all my time, and still do so, that I do not see any chance of being able to do this for some time, and therefore send the process just as it is, that it may be tested and discussed by more able photographers.

Hoping that I may have communicated one useful hint for the benefit of others, in return for the many which I have received through your valuable journal,—I am, sir, your obedient servant,
JOHN G. LIVESAY.

Talk in the Studio.

COLOURING PHOTOGRAPHIC PICTURES.—A patent has recently been taken in the United States for colouring photographic pictures on albumenized paper with dry colours. Such pictures, owing to the albumenized paper not being capable of receiving dry colours without some preparation, and no perfectly suitable preparation having been heretofore known, are commonly coloured with water colours, and this can only be done successfully by skilful artists so as to bear the close inspection to which such pictures are subject. This invention consists in the use of collodion as a medium for receiving dry colours on such pictures.

THE ECLIPSE OF THE 17TH INST.—We have received from Mr. W. Deane, of Richmond, Surrey, an interesting card picture of the partial eclipse of the sun on the 17th inst., taken 6h. 10m. p.m., a little before the greatest phase of contact. The crescent sun is bright against a dark looking sky, and is surrounded by singular radiations of light, assuming almost the shape of a cross. Some foreground objects loom black and heavy against the sky, and give force to the picture.

To Correspondents.

- C. C.—We have not found any injurious effect from the use of water containing traces of carbonate of lime. If present in large quantity a film of carbonate of silver is sometimes formed on the surface of the print when washing before toning. This may be removed by sponging. 2. The bath of acetate of soda and gold should be made 24 hours before use. 3. Sutton's calcio-chloride of gold has been in the market for several months, how long we are uncertain. It is to be had of Bailey and Son, of Wolverhampton.
- D. G. SUTTON.—The colour of the interior of a glass studio is somewhat a matter of taste. Any quiet agreeable neutral colour may be used. 2. From your description the negative collodion has become insensitive through age, which has caused decomposition. It is not a usual circumstance with the collodion of the maker you name. Probably he could give you some explanation. When once collodion becomes insensitive through age there is no efficient remedy. Adding a little of a bromide will sometimes effect a little improvement, however. Sometimes you may mix such a sample off with a more sensitive sample with advantage.
- E. E.—Of the two lenses you name, a half-plate and a No. 2 B of the same maker, the latter is more suitable for cards than the other. The half-plate will take excellent cards, but will require a longer room and will not be so rapid as the No. 2 B. You cannot do better than use the latter.
- D. DEAN.—We are always anxious, of course, to obtain the details of successful formulae for publication. But where there is a specific reason for not publishing we always respect any confidence reposed in us; we shall, therefore, have pleasure in receiving the information either for private use or for publication as you may decide. We think Schering's paper is prepared either with zinc white (oxide of zinc), or mineral white (sulphate of baryta).
- AN AMATEUR.—Shellac varnish is made by dissolving the resin in wood naphtha or alcohol. It may be applied with a brush. 2. We have no information as to when Mr. Keene's work on "Rapid Dry Collodion Process" will be ready. Major Russell's new edition is, we understand, in the press, and will shortly be published. We have no information as to when the English translation of Dr. Monckhoven's manual will be ready. 3. Where you send for the catalogue of any firm, enclosing stamps for postage, and do not receive a reply, we presume the matter has been overlooked, or possibly the catalogue is reprinting. 4. You may use the shellac varnish for the inside of a wooden bath. 5. The best cement for glass vessels to be used in photography is marine glue. 6. If your nitrate of silver solution has become discoloured by standing in the light, it indicates the presence of some foreign matter. Let it stand in the sun a few hours and then filter, when it will probably be all right.
- R. G.—We are glad you have found the iron intensifier so efficient; and also that you are so busy and successful. We do not know of a printer at present, but will bear the matter in mind.
- J. ANDERTON.—The difference in the colour of your negatives with the same collodion in two different baths arises doubtless from the old one containing some organic matter, whilst the other has none, and possibly too much nitric acid. It is possible also that the new one is not quite saturated with iodide of silver. A collodion richer in gun-cotton will give you a creamy film without interfering with rapidity. 2. The cause you mention readily accounts for the want of light in your glass room. 3. We do not know that either of the gentlemen you name could aid you much. You need not apologize or besitate to apply to us for advice. If you send us an addressed envelope we can send you the address of some skilled portraitist.
- P. M.—Lanc Price's formula for a negative bath differs little from that gene-

rally in use: dissolve 1 ounce of nitrate of silver in 2 ounces of distilled water, and add 4 grains of iodide of potassium dissolved in a drachm of distilled water, and shake well. Then add 14 ounces of distilled water, and filter out any precipitate which is formed. Next add alcohol 2 drachms and sulphuric ether 1 drachm; and make the solution very faintly acid with acetic acid. 2. Carbonate of lime is common chalk.

J. BURGESS.—Twelve grains of chloride of ammonium are more than are necessary to each ounce of albumen; 8 or 10 are sufficient. 2. Diluting the albumen will give a less glossy surface; it is a matter of taste as to which is best. 3. It is always best to use fresh eggs, but it entirely depends upon the state and temperature of the weather as to how long the albumen can be kept without absolute deterioration. 4. Extreme care in manipulation and practice alone will enable you to avoid air bubbles. 5. Judging from appearance, without actual trial, No. 1 is best of your samples.

JAMES DATE.—We cannot account for the discrepancy of your experience in using the acetate bath, with that of others. We find no difficulty in keeping it, nor in using it over and over. Some very first-rate photographers like it best when it has been used once or twice. The brown print appears to be scarcely toned at all. Try the lime formula.

HYPO.—Some of your prints are good, but there is in many a tendency to flatness from the presence of too much front light. There is also in some a little want of sharpness. The printing is pretty good.

F. BRIGGS.—The case you state certainly seems a preposterous and unreasonable one. It seems incredible that the accumulated residues of nine months, consisting of two gallons of thick argentiferous "mud," should only yield the value of 1s 6d. in the precious metal. But we don't see how we are to help you. If you mingle all your residues, containing fixing solutions together, bear in mind that common salt is not the material to precipitate them, but liver of sulphur. If you added hypo solutions to these residues, any chloride of silver present would be dissolved and washed away. In such case your "mud" might contain very little silver.

T. A.—The answer given to you by Mr. Crookes was based on the experience of Mr. Piazz Smyth, which is not contradicted by any other evidence that we are aware of. Mr. Glaisher's experiment has so far illustrated that there was less actinism at an altitude of three miles, but not that there was less light. We will, however, take an opportunity of submitting your letters to him. His address is, Royal Observatory, Greenwich.

MOSTON.—A considerable number of articles on photographic engraving have appeared in the PHOTOGRAPHIC NEWS. We may mention Nos. 7, 15, 38, and 40, as containing interesting articles on this subject. A mixture of bitumen and bee's-wax—the latter in small proportion—is used to resist acid.

BACUP.—There are a number of excellent and cheap photographic manuals Bland and Co.'s PRACTICAL PHOTOGRAPHY, and our ALMANAC will equip you with information. Mr. Hughes's Manual, of which a new edition is in the press, is very excellent.

E. E.—Add common salt, until all the silver is thrown down, and then reduce it as described by Mr. England in our last. Or if you do not wish to obtain metallic silver from the solution, but merely solid nitrate, evaporate by gentle heat.

H. FIEBER.—We have examined some samples from the firm you name, and found it very good, but we cannot state that it is all so.

T.—Some back numbers of the PHOTOGRAPHIC NEWS can be had, but some are out of print. 2. A nitrate bath, of 50 or 60 grains to the ounce, will give you a rich vigorous image, but unless it is very acid it is unmanageable, and apt to cause stains, &c. 3. If you tone in a diffused daylight, you do not peril the permanency of your prints, but you risk degrading the purity of the lights. 4. The only use of alcohol in the developer is to enable it to flow freely over the plate, when the bath is old—otherwise, it is better absent. 5. Old collodion baths should not be used for printing—the prints are generally poor, and do not tone well; besides, 45 grains to the ounce is not strong enough. The prints cannot be very brilliant or good.

W. W.—Our pages abound with articles on the production of transparencies for the magic-lantern, &c. We may call your attention to two numbers in our last volume, giving details, viz., 188 and 208. Albumen plates give great force and crispness, but we have seen transparencies on Tannin plates, which were scarcely inferior, whilst the trouble of preparing them is much less. If you produce transparencies by the wet process, the simplest method of changing the colour to black is to treat them first with bichloride of mercury, and, after washing, apply a weak solution of ammonia. 2. A thin, highly-albumenized paper is best for cards. See our ALMANAC, for various toning solutions, with the characteristic qualities of each.

VERAX.—A silver solution is not weakened by standing in an open vessel; sometimes, indeed, it becomes stronger, by the evaporation of the water; but the plan is a slovenly one, as the solution must become contaminated by dust, &c. The best plan is to use the silver meter from time to time to test the strength. A little colour in the printing bath does no harm, but it is better to keep it clean by adding now and then a few drops of a solution of salt, and shaking. If a print remain 10 minutes in a toning bath without any change of colour the bath must be very inert indeed. Prints should be rinsed after toning before passing into the hypo bath. The time required for fixing is generally 15 or 20 minutes.

Several Correspondents in our next.

Photographs Registered during the Past Week.

- MR. A. S. WATSON, 2, Regent Road, Great Yarmouth,
Two Photographs of Rev. — Campbell,
Two Photographs of Percy Rosell.
- MR. JOSIAH GROOM, Wyle Cop, Shrewsbury,
Photograph of W. J. Clement, Esq., Mayor of Shrewsbury,
Two Photographs of Lord Hill,
Photograph of Rev. James Jardine Rogerson, M.A.,
Photograph of Rev. Chas. Edward Leopold Wightman, M.A.,
Photograph of Mrs. Julia Wightman.
- MR. AUGUSTUS EDWIN SCALES, Hartlepool,
Photograph of St. Hilda Church, Hartlepool.
- MESSRS. W. AND D. DOWNEY, 9, Eldon Square, Newcastle-on-Tyne,
Photograph of Birkett Foster.
- MR. WILLIAM HARDING WARNEK, Ross, Herefordshire,
Photograph of Lieut. Rhind.

THE PHOTOGRAPHIC NEWS.

Vol. VII. No. 247.—May 29, 1863.

CONTENTS.

	PAGE
Recent Modifications in the Tannin Process	253
Scientific Gossip	254
A Plan to make Conservatories available for Photographic Pur- poses	255
Form A and its Developer. By K. Staunton	256
The Diorama and Photography	257
Dry Collodion. M. Liezantz on Mr. Keene's Process	258
Collodion: Wet or Dry. By M. L'Abbe Despratz	259

	PAGE
On Photography as a Fine Art. By W. D. Clark	259
Photographic Piracy	261
Proceedings of Societies	261
Correspondence—Foreign Service, &c	262
Photographic Notes and Queries	263
Talk in the Studio	263
To Correspondents	264
Photographs Registered during the past Week	264

RECENT MODIFICATIONS IN THE TANNIN PROCESS.

THE tannin process in its original simplicity rarely fails to give good results where the manipulations are conducted with reasonable care and the materials are moderately near the mark as to purity and exact formula. As modifications are introduced, difficulties begin to be felt, and it has generally happened that these difficulties have borne a somewhat definite ratio to the increase of sensitiveness gained. The more sensitive the film becomes to light, the greater the tendency to fog and other troubles—such as want of intensity, &c. These conditions are not necessarily confined to the tannin process, but appertain, in a greater or less degree, to all processes, wet or dry; and we simply note the circumstance to remark that in proportion as improvements in sensitiveness are effected, in such proportion will precision as to formula and care as to the manipulation become imperatively necessary.

The increase in the proportion of bromide, whilst it gives increased sensitiveness and softness, renders necessary more care to secure other conditions of vigour. The use of ammonia in development, whilst it shortens the exposure, demands more care to avoid fog and stains. The use of hot water in development brings about similar results. The addition of honey or gum to the tannin, whilst it has in many hands increased the sensitiveness, has in others injured the stability or keeping powers of the plates. The latter aids, the use of honey or gum, or the aid of heat in development have proved, in Major Russell's hands, of such doubtful value that he does not adopt or recommend them as integral portions of his process.

On the other hand, we may remark that the most successful rapid tannin photographs we have seen, have been obtained by one or the other of these aids. The best rapid dry-plate picture in the late Exhibition was Col. Stuart Wortley's quasi-instantaneous "Sun-set at the Island of Ischia." This was obtained on a large tannin plate with a Dallmeyer's triple lens, highly-bromized collodion, and the aid of heat in development. With the aid of honey and other modifications, Mr. England has obtained some of the best and most rapid tannin negatives we have seen. His experiments are not yet completed, and as there is some probability that he will compete for the Marsell's prize, he does not at present publish his formula; but we may state that on a recent visit to his studio, we saw a plate exposed which gave a moderately good and very soft negative, produced in a very bad light, with about double the exposure which would have been necessary for the wet process. Other negatives we saw which had been produced in a good light, that had all the delicacy and general characteristics of those obtained on wet plates.

We are at liberty to mention so much of Mr. England's operations as may be suggestive to other experimentalists. A very large proportion of bromides is used, and in some cases an equal proportion of iodides. In the case of the

plate we saw exposed, the collodion had six grains of iodide and six grains of bromide to the ounce. The plates were well washed and the preservative contained both tannin and honey, five grains of each in an ounce of water. After exposure, the film was moistened with common water: a solution of carbonate of ammonia, a grain and a half to the ounce of water was then applied, which brought out a phantom image. Next a mixture of this solution with a little pyrogallic acid was used, by which the image was fully developed; but without vigour. It was now intensified with pyro and silver in the usual way. The whole operation of development did not occupy more than four or five minutes, was effected without any fog, giving an image very like that of a wet plate, and although the glass had no preparation except grinding the edge, there was not the slightest tendency to loosening of the film manifest. We have since printed the negative and although it looks unusually thin for a dry plate it prints well.

Major Russell who has been indefatigable in establishing the conditions of success in working his process, has recently in answer to the queries of one of our correspondents, furnished us with copious and interesting details as the probable sources of certain difficulties to be met. And as the difficulties of one experimentalist are probably those of many, we shall give here a condensation of those of the correspondent in question, and then add the information with which Major Russell has so kindly favoured us.

Our Correspondent, who signs himself "Tyro Tannin," says:—

I made my collodion exactly as in Major Russell's formula. The plates were coated with a rather strong solution of gelatine put on warm. The bath was sixty grains to the ounce, saturated with bromide of potassium, and slightly acid with nitric acid (is this right?). The developer, six grains, carbonate ammonia, one grain pyrogallic acid to the ounce. In the first place, I found the film tender in the bath, and easily torn or peeled off, and when it got through the washing entire on development, in all cases ran into blisters. In one or two instances I have been able to get the picture to the proper intensity without fogginess, but it has almost always fogged over when about half-finished, although I did not keep the developing in and it always remained quite clear. On trying to finish the development, with the ordinary pyro-gallic acid and silver, having washed off the carbonate of ammonia, I found that the blisters condensed.

I have tried a few plates, from which the following appear to be the results of different ways of developing:

That newly mixed or old mixed developer, six grains ammonia, one grain pyro, are equally good and both for the picture before completion. That development in a tray of the solution has no advantages in that respect. That an advantage seems to be gained by covering the plate first with a very strong solution of carbonate of ammonia, which starts the development, and on adding a few drops of a solution of pyrogallic acid, one grain to the ounce, the development proceeds rapidly.

The process appears to be extremely good as to sensitiveness. I tried a plate with part ten seconds, and other parts twenty, thirty, and forty seconds respectively. In the ten

seconds, all the details appeared to be out, but it remained very faint. I should say that my lens is a Ross's orthoscopic, and I was working with full aperture.

I made a print from a trial plate this morning, but had not time to tone or fix it; but as it may be interesting to you to see it, I enclose it. The negative was exposed forty seconds above lens, with full aperture: this was much blistered, but the development having been completed without any silver, no spots to transmitted light were formed, although by reflected light it is much spotted.

Major Russell, in replying, first explains that in a recent communication, the object of recommending five parts of ether and three of alcohol, was to secure sufficient setting qualities in collodion made from ordinary samples of pyroxyline, as the effect of a bromide only is to retard setting. Equal parts of alcohol and ether may be used with advantage with a suitable sample of pyroxyline. The cotton we have generally used and recommended, namely, that made with equal parts of nitric acid at 1.420, and sulphuric acid at 1.840, the cotton being immersed at a temperature of 150° Fah., Major Russell finds very sensitive but deficient in setting powers when a bromide only is used. In reference to the difficulties of "Tyro Tannin," above given, we make the following extracts from the Major's communication:—

I will do my best to explain your correspondent's difficulties, but cannot be sure about their cause, as so many things may produce the same faults. I was much interested in hearing his experience as I have been working quite alone, and have had no report of my method from any one except Mr. Glover, of Liverpool, who found it succeed well, and said that the gain in sensitiveness was even greater than I said. I regard your correspondent's account and specimen to be very favourable, as the difficulties he complains of are very easily avoided, and he seems to be quite free from the only real difficulty in working with tannin—blurring and loss of distance with landscape subjects. I find that this difficulty is entirely avoided by the use of bromide alone.

With regard to the difficulties, the gelatine solution was probably too strong. I never use it now stronger than 2½ grains to the ounce: one drop of glacial acetic acid is quite enough, I find, for double this quantity. If much acid were used, and not well driven off by heat, the evil would be increased. The pyroxyline was probably of an unsuitable kind, intended for dry plates, and perhaps of such a kind as would make too thick a collodion with 5 grains to the ounce; samples vary greatly in this respect. The tannin solution, perhaps, did not contain alcohol enough to penetrate, and the film might not be long enough subjected to its action to allow it to penetrate sufficiently, but the evil evidently commenced sooner. The fogging might be caused by the bath being impure, as one kept permanently acid is sure to be; or by using strong solution of carbonate of ammonia, which is pretty sure to produce more or less fogging; or very probably by light affecting its plates while being prepared.

It is better to give a plan which will succeed well than to go deeply into the causes of failure, at least this course takes less time. Although the coating of gelatine will work well in my hands with bromized collodion and the alkaline developer, I think that the following plan is better in this case. When the glasses are cleaned make them pretty warm, and paint thinly round the edges with a 2½-grain plain solution of gelatine. It dries as fast as laid on. When cold cover the whole with a very weak solution of india-rubber, or india-rubber and amber in chloroform and benzole: all this takes but a few seconds for each plate if many are done at once. After this, in my hands, the film does not move at all throughout the whole treatment. I find it best to keep the bath solution with carbonate of silver in the bottle, and, if necessary, to acidify after pouring out for use with a very small quantity of nitric acid. If the bath has been much used in an acid state it should first be made alkaline with ammonia and well boiled, or exposed for a few days to the sun, then filtered, acidified with nitric acid, and neutralized with carbonate of silver. This way of managing the bath will, I think, be found to be by far the best yet devised.

Immerse the plate when perfectly freed from nitrate in an 8-grain solution of tannin in water, and a large proportion of alcohol, wash uniformly till oiliness disappears, and dry spontaneously. Great care must be taken not to expose the excited plate to even the most non-actinic light more than is necessary,

as bromide is very easily affected by coloured light, and fogging is often thus caused.

The best formulæ for the alkaline developer I find to be as follows:—

		No. 1.	
Carbonate of ammonia	6	grains.
Alcohol, 830	1½	oz.
Distilled water	2½	ozs.

This may be left mixed any length of time in a bottle.

		No. 2.	
Pyrogallic acid	1	grain.
Alcohol and water in the same proportion as in No. 1	2	drachms.

This should be freshly dissolved diluted from an absolute alcohol solution.

Pour on the dry plate enough of No. 1 to cover it, by tilting; two drachms is ample for a stereoscopic plate; let it remain on some minutes, at least, then pour off and mix with one-fourth its bulk of No. 2, pour on so as to sweep the plate all over on tilting, as with an iron developer on a wet plate, for the image, if sufficiently exposed, starts out at once. Pour on and off a few times quickly, and then let remain at rest. If not too much exposed it will be come sufficiently intense in an hour or two, during which it requires no attention.

If too much exposed it must be washed off quickly and intensified with pyrogallic and acid silver, but the film must be well washed between the two operations—insufficient washing may have caused some of your correspondent's troubles. On no account must more ammonia be added after the mixed developer is once on the plate, or fogging will be caused.

I find that the pyro and carbonate of ammonia, when once mixed, quickly loses force, so that if the same mixture is used in rapid succession on two or more plates, the first will always come out best.

However the development is performed, it is important to have a large proportion of alcohol in the liquid which first moistens the film to avoid risk of its becoming loose; if alcohol was not used it would account for the loosening.

Your correspondent's plan of using the carbonate of ammonia in strong solution is, I think, a very bad one, and nearly sure to produce fogging, as I said before. The pyrogallic should be added all at once—subsequent additions after a few seconds' development do no good. The pyrogallic may be used in larger amount, but I recommend that the strength of the carbonate ammonia solution be not exceeded. I hope I have given sufficient explanation to enable your correspondent to avoid his difficulties, which probably rise from a combination of causes. The plan I have described answers perfectly well in my hands, and seems quite free from difficulties.

I may add that I never recollect to have found the film tender under any circumstances when on gelatine. Although strong carbonate ammonia produces slight fogging, yet it might cause less than the proper method if the plates have been injured by light, as the strong alkaline liquid produces great intensity quickly, but makes the plate appear less exposed, that is, fails to bring out feeble impressions of light, whether made in the camera or out of it. I have no doubt that the great sensitiveness of the plates prepared with bromide alone, together with the sensitiveness of the bromide to coloured light, will cause difficulty when great care is not taken about light in the dark room.

We understand that the second edition of Major Russell's little work on the Tannin process is now in the press, and will shortly be published. It will doubtless contain much valuable information on this interesting subject.

Scientific Gossip.

NEW SOLVENT FOR SILK—IMPROVED SPECTROSCOPE.

In our former volumes we gave some notices of a process for dissolving cellulose (cotton fibre, &c.) in an ammoniacal solution of copper. Several attempts were made to utilise the solution thus obtained in photography, and indeed in our

pages will be found details of processes which, whilst tolerably successful in themselves, promised still further valuable results if the subject had been taken up by more experimentalists. Probably the great excess of ammonia which it was necessary to have in this solution, and the consequent unpleasantness of working with such a liquid under one's nose, together with the danger to other photographic operations which would be likely to arise if these fumes were allowed to escape into the photographic laboratory—all acted as reasons for preventing this path of inquiry from being followed up. Some recent researches of Mr. J. Persoz have resulted in a similar discovery of a solvent for silk, which does not touch wool or cellulose, and further trials have shown how to separate all the chemical solvent from the silk, and leave the latter in the state of pure aqueous solution. We have little doubt that this solution of silk would prove of great value in photography, and for the benefit of those who may desire to experimentalise on the subject, we will give the process employed by the discoverer to obtain such a solution. Silk rapidly dissolves in a hot concentrated solution of chloride of zinc and more slowly in a weak and cold solution. But though chloride of zinc readily dissolves silk it does not destroy the texture of wool or vegetable fibres, so that by means of this reagent the complex nature of certain tissues can now be more easily distinguished.

Thus the silk may be dissolved by chloride of zinc, and the wool destroyed by soda, so as to leave only the vegetable fibres. To different learned bodies samples of wool and silk tissues have been exhibited, a portion of which has been dipped in chloride of zinc. The silk was all dissolved out whilst the wool was left intact. The solvent employed by M. Persoz is chloride of zinc concentrated to about 60° of the areometer. This is to be boiled with excess of oxide of zinc until it becomes sensibly neutral to litmus paper. It is in this state a basic chloride; when distilled water is added to it, it does indeed become slightly turbid, but the solution has the advantage of causing no alteration in vegetable tissues which may have to be isolated in the course of the experiment. If excess of free hydrochloric acid be present it might dissolve cellulose, as this acid has been found to exercise a strong solvent power on vegetable fibre.

On contact with chloride of zinc prepared as above described the silk is converted into a gummy mass, preserving at first the form of the threads of the tissue, but changing gradually to transparent clots, and finally becoming completely dissolved. In fact the process of solution is very similar to that of dissolving gun-cotton in alcoholised ether. Chloride of zinc of the above strength gradually dissolves a considerable quantity of silk at the ordinary temperature; but under the influence of heat the solution is effected in a few instants, becoming viscous and capable of being drawn into threads like a thick syrup. It then resembles a strong solution of gum arabic. Ammonia produces in this solution, after dilution with water, a white precipitate which dissolves completely in an excess of reagent. Probably this is oxide of zinc. M. Persoz does not say if he has taken any steps to ascertain whether it contains any silk precipitated along with it. Many chemical means have been tried to separate the silk from the chloride of zinc used as a solvent; but after once being obtained in solution it resisted all attempts to separate it until the beautiful dialytic method of Professor Graham was tried. The silk solution was first diluted by pouring it into water acidulated with hydrochloric acid. Acid was used in preference to water as the latter alone would induce the precipitation of the basic chloride of zinc referred to previously. The acid prevented this. In a former experiment the solution, having been twice filtered without getting rid of its slightly opalescent appearance, was placed on the dialyser. A large quantity of chloride of zinc passed directly, and after a few hours the liquid became much more viscid. It then increased in volume and became an opaline, jelly-like starch. This jelly contained yet a little chloride of zinc which could not

be separated on account of the new physical condition of the matter. It had the insipid taste and smell of starch, whilst its chemical characteristics were dissimilar. In fact, it did not swell with caustic potash nor liquify with sulphuric acid. It was soluble in acetic acid like steeped starch, yet, if dried, it no longer dissolved in this reagent, being transformed into vitreous and brittle fragments. In succeeding experiments the formation of this kind of fibrine starch was prevented by diluting the solution with more water before submitting it to the action of the dialyser, and especially by heating it for a few minutes, which effects the removal on subsequent filtration of the matters in suspension, to which is due the opaline appearance of the liquid. With these precautions, and by means of the dialyser, all the chloride of zinc can be separated and a limpid, colourless, and tasteless liquid obtained, being, in fact, a pure, aqueous solution of silk. This by evaporation gives a gold-coloured, friable varnish. We cannot help thinking that this aqueous solution of silk would prove a most valuable vehicle for the photographic chemicals. It would, we think, be superior to albumen in many respects, and for all processes in which this liquid is now used it might be experimented upon. The expense of preparing it would be very trifling, and the trouble equally unimportant. Chloride of zinc is cheap enough, and the whole of it would be recovered for a subsequent operation by evaporating down the solution which passed through the dialyser.

A very ingenious form of spectroscope has just been completed at the suggestion of Dr. Walcott Gibbs, involving a new principle, or rather one for the first time applied to instruments of this kind. In this instrument the prism of flint glass has a refracting angle of only 37°: the rays which diverge from the slit are rendered parallel in the usual manner by an achromatic lens having the slit in its principal focus. The bundle of rays then falls upon the first surface of the prism at a perpendicular incidence, and of course makes an angle of 37° with the second surface. Under these circumstances the refraction takes place at an angle so near the limiting angle that the refracted rays emerge nearly parallel to the second surface of the prism. The amount of dispersion produced in this manner is very great, while the loss of light occasioned by reflection at the first surface in prisms of 60° placed in the position of minimum deviation is avoided. The spectrum thus produced possesses remarkable intensity, and the dark lines are seen in countless numbers and with great distinctness. The instrument in this form is sufficient for all chemical purposes, but it is so constructed as to permit the use of a second prism by which the length of the spectrum is of course greatly increased.

Though the telescopes are only 6 inches in length, with a magnifying power of about 6, the spectrum compares very advantageously with that of a large apparatus with telescopes of 18 inches focal length and $1\frac{1}{2}$ aperture, and a prism of 60°. It may here be mentioned that the centre of the second surface of the prism lies in the vertical axis of the instrument and also that in a prism of this kind the refracted rays diverge as if from a single radiant point, which is not the case with prisms of the ordinary construction, the angular dispersion being at the same time much greater.

A PLAN TO MAKE CONSERVATORIES AVAILABLE FOR PHOTOGRAPHIC PURPOSES.

It is undoubtedly desirable to have the glass studio so constructed that no sunlight can enter, for with the light from the north or north-east it is much easier work for the operator, the exposure being moderately uniform during the working hours of any ordinary day. But there is a very large class of photographers—especially that enthusiastic, untiring body of hard workers called amateurs—who are compelled to utilize various conservatories already in existence, and as the sun is blazing down upon them throughout the day,

they experience no little difficulty in securing anything like presentable results. The object of the present remarks is to describe how the difficulties were lately overcome in the fitting up of a glass house facing the S.E., trusting they may be of service to many who have no alternative but to use some place with this very undesirable aspect. The house I refer to is situated at the bottom of my garden, and is 32 feet long. It is built against the end wall, and resembles in most particulars an ordinary lean-to conservatory. The whole of the roof is glass, and there is about 9 ft. glass in the side nearly in the centre of the building. Of course I found on dull days a great deal too much diffused light in the place: the pictures taken being flat and unsatisfactory; whilst on bright days I had a blaze of sunshine in the place and could do nothing.

I first tried blinds all over the roof and a black canopy over the sitter. This, however, answered indifferently, for while on dull days I could, by pulling up one of the blinds in the middle, let in a little pure light, and so got good results, yet when the sun shone and all the blinds were down, I had a grey diffused light and could get no roundness. I now determined to shut out all the light except about 12 ft. in the centre; and accordingly papered the glass with thick dark blue paper such as is used for wrapping up goods by chemists. I covered all the glass at each end with this paper, and half-way down the sky-lights in the centre. The following diagram will best illustrate what I mean.



The shaded parts show the amount of skylight covered by paper. It will be seen that a very small portion of the sky-light is left uncovered.

I now had made two light frames, and covered them with very thin white tissue paper. These frames were half the length of the sky-lights left white in the diagram, and were made to fit exactly into the recesses formed by the bars supporting the roof. They were now placed in position, and held there by a few nails lightly driven. Three pieces of wood planed smooth, and about an inch each way broader than the bars supporting the sky-lights were now screwed on the bars. The centre one forming a double groove, thus:—



The two end pieces, of course, were not so broad, as only single grooves were needed. As soon as the three pieces were in position the nails were pulled out. A cord was now fastened to the top end of the frame and carried through a pulley at the top and a corresponding one at the bottom. By this means in dull weather the transparent frames were pulled up to the top under the blue paper, but in bright weather they were let down and effectually shut out the sun, but admitted a large amount of pure bright light. The tissue paper, when in its place, looks like ground glass, but lets in, I think, more light. It is quite out of the way, and therefore not likely to get torn. It is somewhat difficult to get the frames in position without tearing the paper, but a little care will get over the difficulty.

It would be possible to do without these frames if the glass house be tolerably high, say 9 ft. at side. The plan to

be adopted in this case would be to go over the portions of glass not covered by blue paper, with paper varnish, adding a little wax dissolved in hot turpentine to it. Now take the tissue paper in broad strips and carefully lay them on the glass and rub them down, taking care not to get air-bubbles. This is somewhat a difficult operation, but to be overcome with care. When all the paper is put on, go over it with the same varnish, but be careful not to put too much on. When dry it will be found very transparent but will let in no direct sunlight.

The side light is of course easily managed. White blinds either to slide or roll will completely shut out the sun at will.

I find, now that I have perfected the arrangements here described, that the light is very nicely managed, and that I get just the effect I desire. The details of the pupil and iris are well made out in the eyes of my sitters: the nose well defined, and from the wall a nice amount of reflection is thrown into the shadow side of the face. The light falling on the sitter is very pure and brilliant even on moderately dull days while sunshine now causes me no trouble, and the sitter is not inconvenienced by it. The exposure for my pictures is very short, being about an average of 10 seconds, with No. 2 stop in one of Squire's improved Shepherd *carte de visite* lenses. The negatives are frequently so round and dense that they need no further intensification.

I have forwarded a print from one of the negatives taken since the alteration, and shall be glad of your opinion thereon.

FORMIC ACID IN THE DEVELOPER.

BY K. STAUNTON.

On reading an article in your columns of the 15th inst., by H. G. Cooper, Jun., on the introduction of "Formic Acid in the Developer," I am induced to offer the formula from which I obtain the best results, as being, I think, more simple, and, consequently, entailing less trouble and loss of time on the operator.

I have for some time adopted this formula with unvarying success, and providing the chemicals are *good*, feel convinced it is to be relied upon.

It is of the first importance that the formic acid be *pure*, its not being so is, I anticipate, the cause of many experimentalists failing, and thus aiding to hinder the general adoption of a process which undoubtedly gives the nearest approach to instantaneous photography yet obtained in our glass houses, besides showing better results than either pyrogallie acid with acetic acid, or sulphate of iron developers. One striking advantage which it possesses over protosulphate of iron is that in the case of pushing the development too far it does not destroy the half tones, but simply reduces the vigour of the negative. When the proper exposure has been given and the manipulation carefully carried out, the negative is soft and harmonious, delicate in detail, and withal, vigorous and clean.

A second and yet more important consideration in its favour is that it requires *no intensifying* save under quite exceptional circumstances.

With an ordinary light I take negatives with very excellent results in one and a half seconds, and in no case do I allow more than *four* seconds exposure, which is *less* than one-fifth under what I give in the same glass room for sulphate of iron development. With this process I was enabled to take a very fair negative of a sick infant in an ordinary sitting room with a *carte de visite* lens at 3 o'clock in the afternoon in 10 seconds.

I have used three samples of collodions, all of which I found equally good, subject to a slight variation in the exposure, viz., Hockin's instantaneous, Thomas's negative and cadmium mixed, and Ponting's.

The bath should be a 30-grain of decided acidity (nitric acid).

	Formula.		
Pyrogallic acid	20 grains
Formic acid	2 drachms
Distilled water	9½ ounces
Alcohol	quant. suff.

On applying the developer the image instantly appears, after which the film gradually darkens, and the image becomes more indistinct. Keep the liquid gently flowing, watching carefully for the precise moment when the image has attained sufficient intensity (which by a little practice may be easily ascertained), then pour off, wash rapidly, and fix with cyanide.

If intensifying prove requisite the ordinary pyrogallic acid, and a 20-grain solution of silver should be employed; but during the past two months I have had three instances only in which I found it desirable to intensify.

If the chemicals be pure, the exposure good, and the manipulation satisfactorily conducted, the high lights will show a thick creamy appearance by reflected light, the half tones being very delicate and pure, and the shadows clean and brilliant.

Failures in experiments often result from the formic acid being too strong, which reducing the silver leaves a greyish-white deposit on the shadows; or, in the case of an impure sample, the image fails to develop beyond a certain point, and by transmitted light shows little more than a cloudy and irregular film.

There are several points of advantage in the use of formic acid besides those tending to the perfection of the art, and which are very important to houses where the business is large, and the economy of time valuable, for the simplicity of the manipulation renders the process extremely rapid. And again, to photographers who are unable to command an abundant supply of water, the film not requiring nearly so much washing between the use of the developer and the fixing agent, as in protosulphate of iron, or pyrogallic with acetic acid development. A third consideration being the rapidity with which negatives by this process print.

THE DIORAMA AND PHOTOGRAPHY.

IN the PHOTOGRAPHIC NEWS for December 19th, 1862, appeared a detailed account, by Dr. Taylor of Glasgow, of certain dioramic effects which he had succeeded in producing on photographic pictures, with a description of the apparatus by which these results were obtained. In this account it was stated that the chief defect—we should have said the only defect—of those pictures, lay in the fact that they could be viewed by only a very limited number of spectators at a time. Since then, Dr. Taylor has been patiently continuing his investigations in order to remove, if possible, this inconvenience. On a recent evening the members of Council of the Glasgow Photographic Association met with a few friends, one of whom was the writer of the present notice, at the residence of Dr. Taylor, for the purpose of witnessing the complete success which has attended his endeavours. In describing the results we shall say little of the technical details by which these have been achieved, already made familiar to our readers by the former account of the dioramic process, but shall briefly notice the startling and beautiful atmospheric changes which by these arrangements are produced on photographic pictures, and their suitability for representation to large assemblies, merely premising that the cosmoramic boxes and magnifying lenses are now altogether omitted, and the picture presented directly before the audience behind a species of proscenium as in the common diorama. In this way the number of spectators may be limited only by the size of the room. In the present instance the picture was seen from a distance of forty feet. The subject of the experiments to which we now refer was a view of the Broomielaw, or harbour of Glasgow, measuring 40 by 32 inches, taken by Mr. Kibble of that city, and generously presented by him for the purpose. Being an ordinary paper

photograph, it was necessarily not transparent, except where the paper by scraping had been intentionally thinned in order to show particular effects of light. One or two slight innovations had also been introduced into the composition of the picture, not to interfere with the genuineness of the photograph, but merely to show the various results to be obtained by the process. Indeed, the first view presented, that of the harbour in broad daylight, was sufficiently common place to show that the subsequent marvellous arrangements which were wrought upon it were solely the result of Dr. Taylor's combinations. On the right stood irregular blocks of tall buildings fronting the river, interspersed with one or two chimneys, which a little manipulation had transformed into turrets; on the left lay the long line of harbour-sheds, surmounted by the masts and sails of the vessels, while in front the spacious causeway street receded in narrowing perspective until lost in that point to which the lines of houses, sheds, and masts converged. So far, the picture was little beyond that of a simple photograph, taken under ordinary circumstances, and in ordinary light, except that every object seemed to possess a perfect stereoscopic fulness and rotundity, and that there was a breeziness and fluttering motion of the sky which gave to the picture an atmospheric distance and a reality altogether unattainable by either painting or photograph, *per se*. This effect was greatly heightened when the drifting clouds cleared away, and the sun burst forth in full splendour—seemingly at a distance far beyond that of the most remote part of the horizon, while at the same time the street seemed to fill with figures of every size and appearance. But in course of time a slight tinge of the coming sunset stole along the front of the houses, the reflection from the sky overhead became less brilliant, while a more positive light was seen to grow in the west, intensifying itself as the clouds gathered and thickened around it, until along the street came a full flood of glory, striking on the windows of the buildings, enkindling the masts of the ships, and even fluttering down upon the orange-tinted causeway. But apparently the wind is still blowing, the afternoon is wearing on, for now across the western horizon come broken masses of flying clouds, orange and crimson and tawny red, until the motion somewhat subsides, and then a blaze of purest rose-colour rises in the west, suffusing the whole breadth of the picture with its wondrous richness and brilliancy. Anything more exquisitely soft and beautiful than this wealth of colour it were hardly possible to imagine; in fact, language falls stone-dead before this triumph of art. Here having reached the very perfection of a summer evening, the sun again shone forth with its setting hues of crimson and gold, and then sunk in the thick folds of cloud.

It has often been said that though it were possible to form a rose of indestructible material, and to scent this rose with the most natural of perfumes, we should not care for it so much as for a real living rose, simply because the latter has a subtle spirit of evanescence which we know is hastening its decay even as we look. This may possibly be the reason why the most perfectly natural of pictures looks so hard and formal and definite when compared to a landscape out of doors; for even in Turner's pictures—which perhaps possess more business and life than those of any other artist—one still must see that though the ruin is falling, it never falls, that though the wind is blowing, there is no prospect of sunny weather behind, that though the hare is scampering in front of the railway-engine, the distance between them is neither increased nor diminished. But in those pictures of which we now speak the most scrupulous fidelity of the photograph may be combined with colour more brilliant than that of the brightest painting, and with the very life and motion and change of nature herself; while the effect may remain stationary or be changed at the will of the illuminator.

Again, the clouds are in motion, by almost imperceptible degrees the houses and masts grow a rich dark purple, while the sky deepens in its fire and becomes striped with bands of every hue and shade. The combinations of colour which

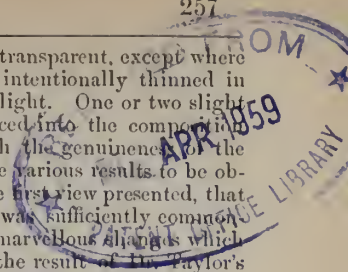

may thus be presented are simply endless; while the brightest of them—those which would look raw and glaring in a picture—are mellowed and blended together with an indescribable softness and transparency. By-and-by, as the light in the west becomes less intense, the gas-light of the shops appears in the darkness, falling with its yellow radiance on the pavement, and lending a soft golden mist to the obscurity of the street; while above, as the sky becomes still darker, a few stars are seen to twinkle forth from over the roofs of the houses.

At this point, as if by magic, there appears in the street a tent, lit inside by a large fire, in front of which several dark figures are standing. This, the spectators were told, is done by an adaptation of the same principle by which the "ghost" was afterwards exhibited. The tent and figures again fade into the darkness, and in their stead come one or two coffee-stands placed along the street with figures as if regaling themselves beneath the glare of the lamps. And now these again are absorbed, and we have a moonlight scene, with the clouds parting and breaking up to allow the silvery radiance to strike athwart the houses and masts as the sunset had done during the afternoon. Nor is it merely a moonlight effect, we have a positive moon, encircled by attendant clouds that reflect her lustre in a thousand different tints. Suddenly, however, thick clouds of smoke are driven across the sky, obscuring the moonlight, and reducing the picture to utter blackness; behind the houses rises a pale red light, growing in intensity until it springs up a clear jet of flame against the dark sky. A building is on fire, and the blaze widens and brightens, then pales and sinks down into thick volumes of smoke, and again the stars come forth. Finally, across the tallest buildings flutters an indication of the coming dawn in a faint tinge of pink—growing from pink to red, from red to gold, and from gold to white, with the ships, and the streets, and the houses once more seen in the quiet light of morning, and the figures, &c., of the night altogether vanished from the scene. It will at once be evident that to produce these varied effects, the operator, besides being an excellent photographer, must have considerable artistic knowledge, and be possessed of very great manipulative skill. The unwearied diligence and well tried knowledge of Dr. Taylor have triumphed over the difficulties which lay in his way; and it is not to be supposed that these results may at once be obtained by any man who makes for himself the mechanical apparatus by which Dr. Taylor has succeeded. If exhibitions of such pictures become popular, as they have every chance to do, it will be necessary that they should not be entrusted to mere showmen, but be regulated by men of personal ingenuity, whose business will be to suggest improvements and to correct what little flaws must necessarily be found in new appliances of the kind. In the meantime, what remains to be done is chiefly the procuring of photographic apparatus competent to enlarge pictures sufficiently to be exhibited in large halls; and as the difficulties which have hitherto existed in this department are merely mechanical, we doubt not that they will soon be obviated. And we can safely prognosticate that when enlarged photographs such as the one exhibited, are procured from localities of greatest historical and scenic interest, such as Egypt, Syria, Italy, or India, and when appropriate figures, and ever-changing effects are introduced into them in the manner that is now shown to be possible, an exhibition at once the most truthful, the most instructive and the most interesting that has ever yet appeared will be presented to the world.

After the removal of the dioramic picture, at the request of several of the gentlemen present, Dr. Taylor showed the apparition of a phantom, or "ghost," in a manner similar to that which is now attracting attention in London. He stated that he had never seen the latter exhibition, but from the accounts published he was of opinion that the means used to produce the illusion must be the same as those described by him in the photographic journals of last year, and exhibited to many persons eighteen months ago.

Accordingly, a table having been placed in the position formerly occupied by the dioramic picture, and a person having been seated at it, as if reading and regaling himself at supper; suddenly there appeared in the air, close to the table, a spectre as of a human figure wrapped in the dress of the dead and gazing intently on the person in the chair. The latter in horror started back, then flew forwards as if to grasp the apparently solid and real corpse, but the hands passed through only empty space, still the apparition persisted, and only signified its feelings by the glare and wild rolling of the eye-balls. This motion of the eyes, after a little, again subsided into a glassy stillness, which had a sufficiently horrible and ghastly effect. The person again made a grasp at the phantom, but in an instant it vanished from sight in the spot in which it had appeared.

DRY COLLODION.

M. LIESEGANG ON MR. KEENE'S PROCESS.

We have frequently requested information on a dry collodion process which would furnish good negatives in the glass room. Mr. Keene's process has given us good results in this particular; the plates prepared, according to his formula only require an exposure in the camera corresponding to double the time necessary for wet plates. Moreover, the process is easy to perform; the negatives develop with remarkable purity.

The method we have followed is as follows. The collodion is composed of—

Alcohol at 40°	10	parts
Rectified ether	100	"
Pyroxyline	2½	"
Iodide of cadmium	2	"
Bromide of cadmium	1½	"

It must not be employed too fresh. The sensitizing bath must contain no nitric acid, only sufficient acetic acid to render the proof clear. To make the solution, dissolve 3 parts of tannin in 50 parts of water; and, on the other hand, 50 parts of gum arabic in 150 parts of distilled water. Filter the first solution, and then add to it the solution of gum; and to the mixture add 3 or 4 drops of formic acid, which serves to give greater rapidity to the plates. If the mixture is not clear, it must be filtered through cotton.

Developer.—That of Major Russell is the best.

No. 1.—Pyrogallic acid	20	parts
Alcohol	100	"
Ether	5	"
No. 2.—Nitrate of silver	2	parts
Citric acid	4	"
Distilled water	100	"

Manipulation.—The plate is prepared in the usual manner, only it is left half as long again in the silver bath than with ordinary collodion, because our collodion contains much bromide, which does not decompose so quickly as the iodides. When sensitized, the plate is left to drain for a few seconds, and the preservative solution is poured on to the plate in quantity sufficient to cover it well. It is left on the plate for a few seconds, then drained off: a fresh quantity of the solution is poured on and off twice more. The last portion will serve for the plate, but it must not be mixed with the fresh solution. After being drained, a little distilled water is poured on to the plate to mix with the preservative solution. In cold weather, warm water must be employed. The plate is next well washed in distilled water and dried.

To develop the picture, the plate must be immersed for two minutes in a dish containing distilled water to moisten the collodion film; it is developed in the usual manner with a mixture of one drachm of distilled water, six to eight drops of the developer No. 1, and three to four drops of No. 2. This mixture is made only as wanted for use.

Before preparation the plates must be carefully cleaned, and covered with a filtered solution of caoutchouc in benzine. —*Le Moniteur de la Photographie.*

COLLODION: WET OR DRY.*

BY M. L'ABBE DESPRATZ.

If, in making use of a sensitizing bath, made old naturally or artificially, we must confine ourselves to the ordinary mode of development—the employment of citric or tartaric acids is altogether impracticable. For the plate, still moist upon its removal from the camera, being covered with all possible care with the developing solution, composed of pyrogallic acid and citric or tartaric acid, no image will appear: we only see here and there at first some grey veins, which gradually darken, and irregularly marble the plate, without any regular production of the image taking place. How does this happen? The silver is reduced—that is evident; but that occurs only in places, and only where the developer has, by its mass, been able to surmount the repulsion which the silver bath opposed to it. This repulsion is enormous. The impressed film, beside free alcohol and ether, contains two fluids which mix with the developing solution with difficulty—dry in its nature, if we may so express it, while, on the contrary, the sensitizing solution is greasy. In a word, and to speak more precisely, all the difficulty arises from a defect of reciprocal affinity, which disappears or even changes into a real affinity capable of promoting the mixture, which is then immediately effected. The inconvenience we here encounter is then absolutely identical with that which we have described in the development with concentrated sulphate of iron acting upon an old bath, and therefore we should have recourse to the same mode of operating. We may be permitted to repeat it in this place, with some modifications.

The plate must first be washed on removal from the camera, until it loses its greasy aspect in the washing water. We then submit it, during a minute, to a new silver bath, strength 2 per cent. This bath must be pure; that is to say, contain neither acid, nor alcohol, nor ether; it should, in a word, consist of neutral nitrate of silver dissolved in rain or distilled water. Under these conditions, this bath will no longer exhibit any repulsion for the developing solution with citric or tartaric acid, &c., and we have now only to facilitate their mixture. To this end, the plate, on its removal from the nitrate bath of 2 per cent., must be slightly drained: it is then placed on a tripod fixed at a level, and raised at one corner, the developing solution is poured on at the upper corner of the plate, and by turning the plate in every direction facilitate its diffusion all over the surface. In the course of a few seconds the mixture is effected, or nearly so; to complete it thoroughly, it is drained into a glass measure, and solution again poured over the plate. This operation is rapidly repeated until the picture becomes visible. A complete repose is then permitted, and we wait until the details are sufficiently apparent. We can afterwards add some drops of the silver solution of 2 per cent. strength, and then the strengthening of the image may be carried as far as desired.

A word now upon the mode of developing most commonly adopted—that is to say, upon the employment of pyrogallic acid mixed with crystallisable acetic acid. The preference constantly given to this mode since it was first pointed out by M. Regnault, is in no way surprising. Its efficacy is, in fact, indisputable, and besides that the manipulation presents no serious difficulty, it is completed with a promptitude that is invaluable. Nevertheless, if we desire all possible advantage from it, there are some delicate precautions to be taken which should not be neglected.

Let us remark in the first place, that the method we have described for citric or tartaric acid, is not wholly applicable to it, as we shall comprehend immediately. By previously covering the plate with the nitrate solution of 2 per cent. and with fresh alcohol, and afterwards developing with pyrogallic acid mixed with acetic acid, the sensitive film exhibits a

very great repulsion for the developing solution, to which the acetic acid gives a consistence somewhat greasy. The mixture of the developer and the nitrate of silver is therefore effected with a certain difficulty. With the ordinary bath containing a strong proportion of alcohol, the difficulty is not so great, but yet it still exists; in either case it is easy to surmount it, as follows. The developing solution being poured upon the plate as uniformly as possible, commencing at one corner, it is immediately poured off at the opposite corner into a test glass, and without waiting for the appearance of the picture, it is poured upon the plate, then back again into the test glass. When the image begins to come out well in consequence of the reaction of the developer upon the sensitizer, we keep the solution on the plate, turning it in various ways so as to keep the liquid in constant motion over the whole surface, and render its action uniform. When the certainty of this equality of action is apparent, we place the plate level on the tripod, and allow the proof time to finish itself. Often, and most frequently, strengthening is not only useless but injurious. Still if it be considered necessary, it must be effected only when we are certain that the action of the developer is exhausted.

We must not lose sight of the fact that strengthening the image is a very delicate affair. It often happens that we, in this way, obtain very intense blacks, which most frequently yield positives with excessive contrast, and in which the half-tones are more or less deficient. When such is the effect of strengthening, we must conclude that it has been exaggerated, or, as is usually the fact, that the exposure was not sufficiently long.

In concluding, it will doubtless be useful to give the proportions we prefer in a developing solution. They are the same as those given in the excellent treatise on *Photographic Chemistry* by MM. Barreswil and Davanne. For the developer with citric acid, the following is the formula of M. Gaillard:

Water	250	parts
Pyrogallic acid	1	part
Citric acid	1	"

We have adopted the same proportions with tartaric acid, and they seem very suitable. As to the developer with acetic acid, we believe it advantageous to increase the proportion of acetic acid and decrease that of pyrogallic relatively. We prefer the following proportions:

Water	250	parts
Pyrogallic acid	0.5	"
Acetic acid	15	"

If the sensitizing bath contains much alcohol and ether, the proportion of acetic acid may be still further increased. The development will be slower, it is true, but it will be more regular and delicate. Only we must take scrupulous care to effect the complete mixture of the developer with the free nitrate of silver on the plate.—*Le Moniteur de la Photographie.*

ON PHOTOGRAPHY AS A FINE ART.

BY W. D. CLARK.*

MUCH has been said of late about the claims of photography to be considered one of the Fine Arts. I cannot help thinking that if the discussion had been conducted with a less display of temper, photographers would have arrived at a clearer estimate of the position due to their art. The claim put forward implies that photography should be held as in some degree equal to the art of painting. But, surely, photography, looked upon as an intellectual pursuit, is far inferior to that noble art. To begin with, it is entirely devoid of the beauty and expression to be got from the use of colour. Imagine artists obliged to produce all their pictures in the single grave colour that the photographer commands, and we at once see how much their art would sink in public estimation.

But this is not the chief disadvantage under which pho-

* Concluded from page 133.

* Read before the Photographic Society of Scotland, May 12.

tography labours. The greatest power the painter possesses is that of giving expression to the human face, or in conveying his own feelings and emotions whilst depicting natural scenery. The photographer cannot do that. He can only copy the expression of his sitter or the landscape before him. He has no power, whatever, of telling a story or appealing to the feelings through the expression of the human face; and this, surely, is the most important point in all high art.* All the photographer can do is to copy his model, and get an agreeable arrangement of lines and light and shadow. Beyond that he is helpless. Wilkie constantly used the model in producing his pictures; but suppose he had simply arranged them in the most agreeable way he could, and made as close a copy of them as his great skill in painting will allow, how small would have been the value of his "Rent Day," or his "Distraint for Rent," and how small the effect they would have produced on the public! No fence would have been needed to prevent injury arising from the visitors crowding round these works at the Exhibition.

Mr. Rejlander's "Two Ways of Life," shown at the Art-Treasures Exhibition in 1857, is, perhaps, the most elaborate attempt yet made to produce a picture by means of photography. The first impression, on looking at it, was wonder at the ingenuity of the author who had produced so elaborate a work with such imperfect means; the second was wonder at what it all meant. The meaning has been explained to us by Mr. Rejlander, but I question if any one could have found it out for himself. If it was unintelligible, it must have been a failure. So with all other attempts I have seen of the same kind; they fail from the total absence of expression in the figures that should tell the story.

The world generally estimates the value of any pursuit in proportion to the intellectual effort employed in it. High scholarship, eminence in science, law, or medicine, are all honoured on account of difficulty in their attainment. We all know how difficult an art painting is, from the small number of those who succeed in it. But there is no great difficulty in producing a first-rate photograph.† A person of average ability, and who can use his hands neatly, if properly taught, could probably become a good photographer in three months. It takes many years' thought and toil before an artist becomes master of his profession. Few men attain this much before middle life. To turn out a first-rate carte de visite is a comparatively easy matter. To paint a portrait as well as Sir John Watson Gordon is a very difficult thing.

What photographer could ever hope to make the most distant approach to the noble picture by Leys, now in the Scottish Academy's Exhibition? Or, to take a much simpler example, was there ever a single figure produced by photography equal in beauty to that of "Antonio," by John Phillip, in the same Exhibition? Again, M'Culloch's picture of "Bothwell Castle" is as true to the locality as any photograph of the same spot could be; but no photograph has yet produced such an exquisite representation of trees, or such a thorough feeling of sunshine, as there is in that picture.

In figure-subjects photography can only copy what the photographer has arranged; it cannot invent. It can reach the excellence of colourless tableaux vivantes—nothing more. To compete with painting is beyond its range; it can never rival that exquisite art.

In landscape subjects the photographer has, to a limited extent, the power of giving *expression* by developing his plate to a certain point, and bringing out some parts more than others, as well as by skillful printing; but this power is within very narrow bounds indeed. The finest photographic landscape, however beautiful in detail, is, in point of *feeling and expression*, greatly below the works of a great landscape-painter.

The imperfections of the lens, especially the small angle it includes, alone place the photographer at a great disadvantage. I am sure that every genuine photographer has felt, on looking at a noble landscape, how little he could do compared with an able painter.

In my own library, David Robert's volumes on the Holy Land and Egypt lay side by side with Frith's beautiful photographs of the same countries. I have often observed how much greater interest friends take in looking over the painter's work

than the photographer's. This is especially the case, I notice, with persons familiar with the countries illustrated.

Even in this instance the comparison is not a fair one for painting, as the original drawings have been translated by the lithographer.

But there certainly is such a thing as *photographic art*, and a very beautiful art it is, and fitted to do wondrous things; and photographers might well be contented to remain within its legitimate bounds. It is by cultivating it that reputation is to be gained, and not by endeavouring to trench on the domains of painting. If the public does not respect the pursuit of this art, depend upon it photographers have themselves to blame. Let them do justice to their own very beautiful art, which is so well fitted to add to the enjoyment of the world, and the public will do justice to them; and then they need not feel vexed even if some future Royal Commissioners declare that their productions must not be classed with pictures in some future International Exhibition.

The irritability exhibited by photographers whilst urging the claim of their art to be included amongst the fine arts, probably shows a lingering suspicion that their cause is not a very strong one.

The extent of the periodical literature devoted to photography is remarkable, and is evidence of the great number of people that take an interest in the subject; yet it probably has not done much to raise the character of the art. These journals profess to include both science and art; but certainly a knowledge of chemistry does not seem to be requisite in many of those contributors who write on photographic processes, and the bad taste displayed by their conductors is sometimes deplorable. An instance of this recently struck me very much. Mr. Mudd wrote to the *British Journal of Photography*, that a person, at a soirée of a Photographic Society in Glasgow, had, as reported in that journal, repeated as his own a little story of harmless humour, that Mr. Mudd had written for another photographic paper some couple of years ago. Instead of simply inserting the letter, there was put at the head of it, in capital letters, "As clear as Mud." This was, probably, intended by the editor for *wit*. To me, it seems to be the grossest impudence. It was, however, too good a thing in the eye of the offending party to be printed only once, so he repeats the buffoonery in his answer.

The editor may not know, as I do, how genial and worthy a person Mr. Mudd is, how anxious and ready he is to communicate to others the knowledge he has of his art, how good a social position he holds; but he *does* know that he is one of the best photographers in this country, and, as such, no liberty of this nature should be taken with him in a journal devoted to photography. I certainly can have no faith in the opinion on any matter of *taste* of a person who displays such an entire absence of it as this editor does in this case, nor do I think he can have much love for the art, when he takes such a liberty with one of its most successful practitioners.

If photography cannot rival painting, it can, I think, be of great use to the artist. A painter of landscape must paint a great deal on the spot; but the amount of materials collected in this way can be comparatively small, especially in such a climate as ours. Photography may be of the greatest value in supplementing his studies from nature. For bits of foreground, rocks, weeds, trees, boats, and for giving the texture of such things as the trunks of trees, it is of the greatest use. A collection of studies of trees of various kinds, showing the general forms and the ramifications of the trunks and branches, could easily be made by photography so complete that the longest lifetime, and the greatest industry, would be unequal to produce with the brush. It is almost impossible to sketch clouds with sufficient rapidity; and certainly no sketch can be so true to nature as the remarkable photographs of skies done by Mr. Breese, of Birmingham. They may be studied by the artist like Nature herself.

If it be a mistake for the photographer to attempt to rival the artist in producing pictures, I think it quite as great a mistake for the painter to try to equal the photographer in his peculiar province. No amount of care and finish will enable the artist to get the exquisite detail that a photographer can obtain in a rocky and weedy bank, for instance. The latter, in an hour's work, would get a more perfect and complete copy of the bank than the artist could with a whole summer's painting. So far as mere copying of little bits goes, the photographer is as superior in detail and finish as the painter is to him in feeling and expression, when Nature is depicted as a whole.

Pictures are sometimes seen in exhibitions that appear

* Mr. Clark here makes a common mistake, in confounding "high art" with "fine art." No claim has ever been made for photography as "high art."—Ed.

† How is it then that there are so few first-rate photographers?—Ed.

painted to rival the photograph in its own walk, but they are cold and unsatisfactory.

Photography is obviously doing good service to painting, by educating the public eye to the beauty of simply an accurate copy of nature. A picture to please now must have the forms of trees, rocks, mountains, and clouds given with truth, and with neither the slovenliness nor the exaggeration that would formerly pass muster.

The forms of rocks and mountains, as drawn by Turner, are sometimes perfectly ludicrous. Ruskin would have us believe in Turner as we would in a prophet. I have surprised some of his worshippers by showing them prints from Turner and photographs from the same point of view.

If I have ever sufficient leisure, I intend to illustrate the "untruthfulness of Turner" by a series of photographs contrasted with his prints.

I suspect that pre-Raffaeltism owes much to photography, or may even possibly spring from it, though its disciples would not willingly admit as much. Post-photography might probably more accurately describe this style of art than pre-Raffaeltism.

PHOTOGRAPHIC PIRACY.

On Friday last, at Marylebone Police Court, Thomas Wilson, stationer, &c., of 90, High-street, St. John's Wood, was summoned for "that he did on the 12th of May wrongfully sell divers repetitions, copies, and imitations of a photograph of eminent persons, about 500 in number, of which Frederick Holland Mare is the registered author and proprietor, under the 25th and 26th Victoria, cap. 68, contrary to the statute," &c.

Defendant having pleaded not guilty,

Mr. Besley, barrister, said that he appeared on behalf of Mr. Mare, a photographer, of Grafton Street, Dublin, of whom Messrs. Ashford, of Newgate Street, are his London agents. An assistant of Mr. Ashford's, on the 5th inst., entered defendant's shop, and purchased two copies of "Eminent Persons," which were piracies from the original. A letter was then sent to the defendant on the subject, cautioning him not to sell any more of them, as by so doing he was laying himself open to a prosecution under the Copyright Act, and called upon him to make some moderate compensation, give an ample apology, and promise not to deal in any more of the spurious copies, and also to give the name of the parties from whom he had the copies.

Defendant: That letter was not sent to me.

Mr. Besley: It must have been received, or else, by the ordinary process of the Post-office business, it would have been returned. However, on the 12th of May, the same person in Mr. Ashford's employ again went to Mr. Wilson's shop and purchased two other copies; and after this Mr. Bird, the solicitor by whom I am instructed, wrote a second letter to the defendant, telling him that he was infringing the copyright of the "Eminent Persons" published by Mr. Mare, of Dublin. Of this no notice was taken. Mr. Ashford was selling the print at the rate of 70 to 100 dozen per day, and of course it must be a very valuable source of profit to Mr. Mare. Proceedings were in process against a person of the name of Ordish, who is the party most to blame, he being the person who is getting up these copies from the original. If his worship would look at the original and the copy through the magnifying glass, he would find that there was a defect in the letter "y" at the foot of the picture, clearly showing that they both could not have been from the same plate. He must say in justice to the complainant that he could not be considered as the most culpable person, but the printer, against whom proceedings were being taken. The defence he has set up, however, is not altogether a very creditable one, for he sets forth that he had purchased them from Mr. Bowling, of Cheapside. Mr. Bowling was there, and would tell his worship that he had only supplied the defendant with six copies of the originals, he (Mr. Bowling) having obtained them from Messrs. Ashford, of Newgate Street. It must appear to his worship as conclusive of the defendant's infringement of the law when he (the learned gentleman) pointed out to him that all copies supplied by Messrs. Ashford bore on the back "Ashford, Brothers, 76, Newgate Street," whilst on those bought at defendant's shop there was no name or address.

Evidence in corroboration of this statement having been adduced,

Mr. Besley, in conclusion, said their object was not to press for punishment, but only that a nominal fine should be imposed, to let the trade know that, though they were not the actual printers and publishers of pirated copies, they had no right to sell them.

Mr. Yardley inflicted a fine of 1s. and costs.

Proceedings of Societies.

NORTH LONDON PHOTOGRAPHIC ASSOCIATION.

The closing meeting before the summer recess was held on the evening of Wednesday, May 20th; Mr. G. Shadbolt in the chair.

The minutes of a previous meeting were read and confirmed.

Mr. G. WHARTON SIMPSON exhibited a couple of prints by Mr. Pouncey's new process, produced in printing ink, direct from the negative, with satisfactory rendering of half-tone. A conversation on the subject followed. The chairman expressed his conviction that a decided advance had been made. Mr. Simpson explained that the process was patented; but, so far as he knew the method, it consisted in coating paper with a preparation of printing ink and a sensitive agent, such as bichromate of potash. This was exposed to the light under a negative. After the proper exposure the print was placed in a solvent of the printing ink, which removed all the parts not acted upon by light.

Mr. SIMPSON also showed a series of interiors taken by Mr. Jabez Hughes, with Dallmeyer's No. 1 triple lens. Some of these consisted of the bridal chambers of the Prince and Princess of Wales, at Osborne, taken on plates ten inches square, showing a large portion of three sides of a room with every object admirably defined, the pictures being very brilliant and with great relief. The lens used, having an equivalent focus of a fraction under eight inches, the pictures included an angle on the base line of about sixty-four degrees, and on the diagonal of nearly eighty degrees. A beautiful interior of St. Mary's Church, at Ryde, on a 10x8 plate, with the same lens, was also much admired.

Mr. SIMPSON also showed an enlarged print by Mr. Stewart, with his new solar camera, printed out, on albumenized paper, in an hour. Also, some very fine specimens on a new sample of enamelled paper, of which Messrs. Harvey, Reynolds, and Fowler are the agents.

Mr. COLLIS exhibited a series of fine views in Wales, taken with Ross's 10x8 triple lens, on 10x12 plates. Also, some with the lens of 8.4 focus, and some with the lens of 9.4 focus, including an angle of 60° degrees on the base line and 66° on the diagonal. These were very much admired.

Mr. FOXLEE exhibited a small camera designed by himself and made by Mr. Hare, for the purpose of taking fifteen "postage-stamp" portraits on one plate. There were five small double combination lenses in a row, and by two repeat movements three rows of images were produced in succession.

The CHAIRMAN exhibited some fine stereoscopic negatives and prints by Dr. Kemp's new dry process.

Mr. MAINWARING exhibited some prints fixed by different agents. Since listening to the paper on fixing by the sulphocyanides at the last meeting he had tried some experiments. He had tried a saturated solution of common salt which he thought answered. He had tried cyanide which destroyed the prints. He had tried a mixture of cyanide and hypo, 1 grain of the former and 4 drachms of the latter in 12 ounces of water, and this appeared to him to fix as satisfactorily as a strong solution of hypo.

The CHAIRMAN referred to early fixing experiments with common salt, bromide of potassium, &c. The real difficulty with any agent which formed an insoluble salt of silver was to get rid of the final traces of it from the print. The great beauty of hypo—if it had any beauty—was that when once the salts of silver were in solution in it they never again, whatever degree of dilution were used, became insoluble.

After some further conversation on the subject the Chairman remarked that it was somewhat unfortunate that the specimens brought by Mr. Mainwaring were all more or less stained and discoloured.

Mr. MAINWARING said that he had done the whole thing in a hurry and not with the care necessary to secure perfect results, as he had not intended at first to mention the subject to the Society, his chief object being to satisfy himself.

The CHAIRMAN then asked if any member was disposed for a photographic trip to Stonehenge, and Wiltshire generally, as a gentleman who was going on a fishing excursion wished for a companion.

Mr. SHADBOLT then vacated the chair to read a paper on "Portraiture in the Open Air," chiefly devoted to a description of the mechanical contrivances for securing shade and shelter, consisting of light screens and canopy to be readily constructed and erected.

Mr. BOCKETT described a very cheap and efficient glass house he had constructed, which seemed to present many desirable points, and of which we hope shortly to give our readers a detailed description.

After some further conversation on the subject,

Mr. BARBER exhibited a sample of iodide of ammonium, produced by the double decomposition of sesqui-carbonate of ammonia and iodide of cadmium. He also mentioned that he had found that iodide of ammonium which had become slightly decomposed and brown from free iodine might have the free iodine removed and be made quite clean by washing with benzole.

Mr. MARTIN mentioned that ether answered the same purpose.

Mr. SIMPSON had used ether and found it left the salt very pure and white.

After some further conversation on this subject,

Mr. SEELEY showed a specimen of portraiture in an ordinary room.

After some further conversation the proceedings terminated.

Correspondence.

FOREIGN SCIENCE.

[FROM OUR SPECIAL CORRESPONDENT.]

Paris, May 27th, 1863.

THE programme of the conditions upon which the prize of 3000 francs, offered by the French Photographic Society for the best mode of producing enlarged positives, is now issued. It states that the object of the competition is to include both the optical and chemical means employed. The prize will be awarded to him who shall have resolved completely, either theoretically, capable of being practically worked, or practically only, the following questions relating to enlarging positives:—

- 1st. Shortness of exposure in the production of the *cliché*.
- 2nd. Freedom from distortion in the negative and in the enlarged positives.
- 3rd. Detail, equality, and sharpness in the image, as in the best proofs by the present direct method.
- 4th. Economical and practical production.

The prize will be divided among several competitors if they resolve any separate question, or in case he who solves the whole, shall have derived any portion of his operations from the ideas of processes of another. The prize will not be awarded if the solutions to the questions be not complete; in such case, the competition will be renewed.

If it be adjudged that none of the competitors have sufficiently satisfied the conditions of the programme to entitle them to the prize, it will be given, as an encouragement, one portion to the author or authors who have made the most important steps towards the solution of the problem, either by the discovery of new methods, or the improvement of those already known.

The competition is open to all the world, without distinction of country or nationality.

It will close on the 1st of October, 1865.

The members of the French Photographic Society will not be excluded from competing.

Communications must be addressed to the *Société Française de Photographie*, before the date above mentioned.

The processes described by the competitors in their communications will be kept secret only till the day of closing the competition but the Society do not intend to

deprive any inventor of the rights conferred upon him by any patent he may have taken out.

The communications, which will be addressed under seal, will remain unopened until the day of closing the competition, after which they will be opened.

At the meeting of the Society in July, 1865, a committee will be appointed to examine the various methods submitted to the Society, and award the prize.

The communications will not be returned, but deposited in the archives of the Society.

M. Kaiser, of Leyden, has made the following communication upon the iron developer combined with sugar of milk. He states that the unsatisfactory results given by sulphate of iron, dissolved in water acidulated by acetic acid, as a developer of photographic images formed in a layer of iodide of silver, have stimulated the production of several formulæ for the preparation of the iron bath. The reducing power of sulphate of iron alone upon the nitrate of silver is so energetic, that it must be diminished by some suitable substance. He is, however, convinced that acid is very injurious to the development of photographic images upon a layer of iodide of silver. If it be true that the iodide of silver, acted upon by light, is decomposed into iodine and silver or oxide of silver. The free acid in the reducing solution will remove a portion of the silver or its oxide, which composes the image formed, before the reducing agent has had time to develop the latent image. With a reducing solution which comprehends only substances which do not attack the silver or oxide of silver, the photographic image will develop itself after a shorter exposure, and even after a very short exposure, because, according to satisfactory experiments, the iodide of silver is instantaneously decomposed by light. The whole art of photography concentrates itself, therefore, in the art of *developing* the latent image produced by the shortest possible exposure to light.

I have found that sugar of milk does not act in any way upon silver or oxide of silver, and the preceding ideas have led me to replace the acids and other substances employed by sugar of milk. The results of my experiments have far exceeded my hopes, seeing that the image develops itself with admirable vigour and delicacy, after an instantaneous exposure. I have employed in these experiments a portrait objective, by Jamin, without diaphragm, for three-quarter plate, and the object photographed was a portion of the Botanic Garden at Leyden.

The employment of sugar of milk, as a substitute for acids, possesses the following advantages.

It is possible to develop a vigorous picture with a concentrated solution of sugar of milk, to which are added a few drops of a concentrated solution of sulphate of iron. The image will appear very slowly, and consequently be of extraordinary delicacy.

It is preferable to use a collodion not recently prepared,—that I made use of in the experiments referred to was nearly two years old.

A nitrate of silver bath of five or six per cent. will suffice, and it is no disadvantage if it contains a very large quantity of salts formed during constant use.

In a word, my iron bath possesses, as a developer, the advantages of the known pyrogallic acid and iron solutions, without their disadvantages. It will produce the latent image after an absolutely instantaneous exposure, without strengthening, and with a delicacy and clearness unattainable, by any other means.

M. Moisson presented to the Photographic Society several specimens of vitrified photography upon transparent glass. He states that he believes this kind of photography may be applied to the windows of apartments. The transparency, free from opacity, will be, he believes, an auxiliary which the glass-painter may advantageously employ. The method is as follows. After taking a transparent positive from a negative, either by contact or by the ordinary method, it is covered with yellow ochre, and when dry exposed to the

furnace in a muffle, until it becomes a cherry-red colour. When cold, the coating of yellow ochre is removed, and the picture is found vitrified.

IRON INTENSIFIERS.

DEAR SIR,—I feel confident that the method of intensifying with iron, recommended by Mr. Livesay in your last number, will be found to be a great improvement on the plan of using the acid exclusively in the iron solution. On reading your article on Mr. Blanchard's suggestion, I intended to have written to you, to recommend that part of the acid should be mixed with the iron, and part with the silver solution; if there is a sufficient proportion of acid in the latter, it may, if required, be added freely without making a coarse granulated deposit, such as is produced by the addition of plain nitrate in too large amount for the acid contained in the iron solution.—Yours truly,
C. RUSSELL.
May 25th, 1863.

THE DOUBLE SULPHITE DEVELOPER.

SIR,—I have read several times in the PHOTOGRAPHIC NEWS the method of developing negatives with the double sulphate of iron, so that they will not require any after-strengthening with pyrogallic and silver. I have tried several of the formulæ, and was at first inclined to think there was no advantage in it,—at the same time thought that it might be possible to do something with it, as I found the negatives developed very clean and bright, but came out very slowly. I therefore made several trials, varying the strength of the double sulphate. My last trial was as follows:—Double sulphite of iron 120 grains, acetic acid, glacial, 20 drops, distilled water 1 oz. I find that it is quite manageable at this strength, as it develops quickly and free from stains, and any amount of density can be obtained in a very short time by continuing the development, without the least fear of fogging the plate, and no pyrogallic is needed. The exposure is also shortened at least one half from the old method with sulphate of iron and acetic acid, and then strengthening up with pyrogallic and silver.

The enclosed print is from a negative taken with the above formula, and the time of exposure was for each picture two seconds with Dallmeyer's No. 2 B carte de visite lens, and No. 4 stop, which is about $\frac{2}{3}$ of an inch opening.

This picture was toned with—

Chloride of lime...	5 grains
Chloride of gold	2 "
Water	20 ounces.

This quantity will tone two sheets of albumenized paper.

I find this developer admirably adapted for instantaneous views. I will shortly send you a few prints from negatives I have taken with this process. If you think this of any interest to your readers, you are at liberty to use it.—We are, sir, yours respectfully,
BECKETT AND WILLIS.

32, St. Nicholas Cliffe, Scarborough, May 19, 1863.

[The prints received consist of eight card portraits of one person, each in a different position, on one large plate. Notwithstanding the large size of this plate, and the necessary lapse of time employed in posing the sitter eight different times, there is not the slightest stain, lack of brilliancy, or variation in quality, throughout the whole. Each one of the eight is a rich, brilliant, soft picture, well arranged and beautifully defined. The tone is a rich, warm black.—Ed.]

Photographic Notes and Queries.

TONING FORMULA.

SIR,—I shall be much obliged if you will give me your opinion, respecting the enclosed formula for toning bath, as I have never tried it. It runs thus:—

Solution No. 1.

Chloride of gold	15 grains
Filtered water	20 fluid ozs.

Solution No. 2.

Phosphate of soda	12 drachms
Distilled water	30 fluid ozs.
Refined borax	3 drachms

Warm the distilled water, and dissolve in it the phosphato of soda and the borax, then add by degrees the solution No. 1. The bath should be used slightly warm, and the prints must be watched, as they immediately take the desired tone; they must then be fixed in a twenty per cent. solution of hyposulphite of soda. The prints must be thoroughly printed till they have almost a steely tone; when removed from the frame they should be washed in a three per cent. solution of salt and water for ten minutes, then in ordinary water, and afterwards toned, and proceed as above.

I do not understand what is meant by steely tone.—I am, sir, yours respectfully,
G. COURT.

[We have no doubt that a solution prepared as above will tone well, but will probably not keep. The term "steely" means, doubtless, very dark and with a metallic lustre.—Ed.]

TONING FORMULA.

SIR,—I send you a new toning bath, which seems to answer admirably—chloride of gold, one grain, chloriato potass, thirty grains, water, six or eight ounces. Take the prints from the frame, and immerse them in water, and from the water to the toning, i.e., don't change the water. This bath works best when old.—Yours respectfully,
PUBLICOLO.

SENSITIVENESS OF SULPHO-CYANIDE OF SILVER TO LIGHT.

SIR,—In your paper read at the meeting of the North London Photographic Society, you stated you had found the sulphocyanide of silver was not affected by the action of light—that being contrary to my previous experience, I tried it this morning. I precipitated some sulpho-cyanide by adding sulpho-cyanide of potassium to solution of neutral nitrate of silver; dissolved the precipitate in ammonia, and crystallized it by evaporation, for the sake of getting it pure. To a solution of ten grains in liquor ammonie, I added one-half grain of nitrate of silver, and applied it by brushing to a piece of plain Saxe paper washed free from salt. The result was, it changed through various shades to a deep violet, in the course of about twenty minutes.

Probably yours did not blacken from the absence of organic matter, which we know is essential in many instances.

Yours, respectfully,

JOHN RUDDOCK.

[In the experiment detailed you did not expose simple sulphocyanide of silver to light, but that salt in combination with ammonia and nitrate of silver. The latter two agents applied to paper would have blacked without the presence of the sulphocyanide, so that the experiment proves nothing. If you refer again, however, to our paper, and to a note which accompanies it, you will find that we state that sulpho-cyanide did darken slightly in sunlight, and it is quite possible that it would do so more energetically if exposed in combination with organic matter.—Ed.]

Talk in the Studio.

LECTURES ON THE PISTOLGRAPH.—Mr. Skaife, who has opened a new studio in Sussex Place, Regent's Park, intends there to deliver a series of lectures on photography, especially in connection with its minute phases, to which he has given especial attention. The first lecture was delivered on Monday, the 18th instant, the chair being taken by Sir David Brewster, who, with several other savans interested in photography, amongst whom were the Bishop of Tasmania, the Rev. J. B. Read, Dr. Cronin, Dr. Purland, and others, was present. Mr. Skaife gave an interesting sketch of the origin of the pistolgraph and of his photographs of the firing of a mortar, its difficulties, dangers, and success. He also related an anecdote of his photographing, with his little instrument, Her Majesty as she was at full speed on her route to Wimbledon, and the risk incurred of being apprehended for an attempt to shoot the Queen. The lecture was illustrated by specimens and demonstrative experiments.

To Correspondents.

POSITIVE.—The formula to which you refer was, as we stated, given at a photographic meeting. We have not tried it ourselves. The strength of the developer, need not, however, in any degree affect the strength of the silver bath used. A bath for positives may contain from 35 grains to 40 grains of nitrate of silver, with from 1 to 2 drops of nitric acid to an ounce of water.

ALABAMA.—The recent decision of the judges regarding photographic piracies of engravings simply determines that when a copyright exists a photographic copy is an infringement of it. Where, from non-compliance with the provisions of the Copyright Act, or other causes, no copyright exists, photographic or other copies are not piracies.

P. T.—It is better to buy marine glue than to make it. It consists of 4 drachms of india-rubber cut into small pieces and dissolved in 4 ounces of benzole, to which 8 ounces of powdered shellac are added, the mixture being melted together by heat. It is then poured out into cakes to solidify. It may be bought at many tool-shops. 2. Glue would be dissolved by steam. 3. It is not injurious to prints to dry them upon blotting-paper. 4. They will not injure by being kept a few hours damp without spreading out to dry; but the sooner they are dried the better. 5. Solutions of carbonate or phosphate of soda do not injure by keeping. 6. The yellow brown precipitate in your developing solution is peroxide of iron. Filter it from the solution. That which forms a hard coating on the bottle may be easily removed by sulphuric acid. 7. The black powder thrown down by sulphate of iron from old toning solutions is metallic gold. The yellow or brown powder may be a little oxide of iron. 8. Your prints must be washed each time with fresh water. The silver in the washing water may be thrown down as a chloride. 9. Your last question, "May I register the colour of prints?" we do not quite understand.

GEO. ATKINS.—We do not quite understand what kind of stains you refer to as occurring always with a new bath. Stains should not so occur. They may sometimes occur from the bath not being saturated with iodide, or from the bath not being sufficiently acid; or possibly from using a developer with alcohol in it, which is unnecessary with a new bath. 2. Old silver baths should not be used for intensifying, but a fresh, pure solution. 3. The print enclosed is very good in some respects, but the lens is of too short a focus for a standing card figure. You may help it a little by using a camera with swing-back which will assist you in getting the feet in focus, as will also a small stop. The No. 1 B of the maker you name may, we believe, be used for card portraits with a distance of 12 feet between the camera and sitter; but the maker can doubtless tell you accurately. If you could in any way contrive to get a foot or two more it would enable you to work with more comfort.

No. 290.—It is evident that you do not tone to nearly a sufficient depth. Let the prints attain a black tone before leaving the toning bath. Read the chapter on toning in our ALMANAC. See also an article on toning which will appear in our next. Avoid the carbonate of soda as a rule.

B. W. S.—The negatives of your card portraits are pretty good, especially the two male figures. Your prints are, however, a little mealy. We shall have something more to say on the subject of toning and meanness in our next. Where you use a pictorial background, involving distinct perspective lines, such as an interior with receding wall, avoid using a carpet with a marked pattern, or anything else which will at once show that the point of sight in the actual photograph and that in the painted accessories are not the same.

H. CRESSON.—The chief cause of your printing difficulties is in your negatives: they are much too weak to yield brilliant prints. You must print very much deeper than you have done in the examples forwarded, and then tone to a deeper colour. It is generally desirable to have some brouzing in the deepest shadows in order to obtain vigorous and richly coloured prints. The behaviour of your hypo solution suggests the probability of some cracks in the glaze of the vessel in which it is kept. It will quickly attack and destroy the glaze of some inferior samples of earthenware. It should not have behaved as you describe otherwise. We do not think it will pay you to recrystallize your hypo simply for the purpose of fixing negatives.

EMILY.—We do not quite understand your difficulty in making chloride of gold. Is it that decomposition occurs whilst evaporating it, causing a precipitate? If that is the case you have probably used too much heat, or possibly added too much carbonate of soda in attempting to neutralize the acid. 2. Much depends upon the tone desired, as to which will be considered the best toning formula. Many persons prefer that with acetate of soda and gold, it generally gives various tints of purple. The solutions containing lime generally give black tones. You will find Ommegance's, Maxwell Lyte's, and many others in our ALMANAC for this year, where also you will find excellent collodion formulae. 3. The subscription to the Photographic Society is a guinea a year, and a guinea entrance. Dr. Diamond, the Secretary, will supply you with information as to the rules.

A. A.—In speaking of "a lens from a common stereoscope" you are much too indefinite, as many forms of lenses are used in that instrument. In some cases half a double-convex lens is used, in some simply a prism; in some a whole double-convex; in some a meniscus. In almost all cases the lens is non-achromatic, and the visual and actinic foci not coincident. It is most probable that to this cause your failure to use it satisfactorily as a landscape lens is due.

EPSTON.—We cannot give you the slightest idea as to the trustworthiness of the various descriptions of second-hand apparatus in advertisements. The best plan, for certainty, is to see the articles before you buy them. We cannot tell you the commercial value of the lens to which you refer. Your best plan, if you wish to make an exchange, will be to apply to some dealer of second-hand apparatus, such as Mr. Morley, who will, doubtless, deal fairly with you. A single lens is better for general landscape purposes than a portrait lens. The especial advantage of the triple over the single lens is that it includes a wider angle of subject, and is free from distortion, giving rigidly straight lines in architecture, &c., which no form of single lens ever does.

A. LUNATIC.—In what condition your negatives originally were, or what causes have been in operation to produce their present deplorable state, we cannot conceive. Moistening a film varnished with spirit varnish with spirit ought to have no more power upon it to produce cracks than the original varnishing had. Possibly your film, consisting of a piece in the

middle of the plate, allowed the spirit to get under by running all round the edges. Possibly it had not been varnished with a spirit varnish before. Apart, however, from the cracks, you have obtained very bad results. Either you must have continued the application of the iodine too long, or the plate had been treated with bichloride of mercury. Instead of obtaining a dense olive-coloured image, you have an image of pale yellow. Your original negative must have been sadly wanting in sharpness and vigour. We have had communications from several readers, amongst whom are very able professional photographers, who have succeeded in making worthless varnished negatives give very fine prints by applying the iodine solution as directed.

A. CONSTANT SUBSCRIBER.—Your only cause of failure is under-exposure, with, possibly, little under-development. So far as we can judge by the results, your bath is in right condition for positives. It is possible that your collodion may be old and insensitive, but as you do not state the length of exposure, we cannot form an opinion on that subject. In any case, with the same materials, a considerably increased exposure, and a little longer development, will give you good results.

JOHN CLESKY.—See answer to P. M., in our last. 2. We believe that the argentiometers are generally sufficiently accurate for testing the printing bath.

F. T.—The fee for registering a photograph is one shilling; the blank form costs a penny; and attendance in person or by an agent at the Register Office is necessary. If you fill up a form properly and send it with 15 penny stamps to our publisher he will register the picture for you. See form in our ALMANAC. The same fee is charged whether the picture be large or small.

P. G.—The reticulation of the collodion film on drying arises from the presence of too much water. The alcohol is not sufficiently highly rectified. When the tendency exists, you may, to some extent, ameliorate it by letting the film set well before immersion in the nitrate bath, and by giving plenty of exposure, so as not to need over-pushing in development.

J. R.—The question "whether photographic chemicals spoil by keeping" is rather a wide one. Some chemicals do spoil, and some do not. As a general principle, they do keep when unmixed. Some samples of collodion do not keep when iodized, or even when plain for very long. Ether is also apt to deteriorate by contact with light and air.

T. B.—The splitting and curling up of the collodion film on drying may generally be traced to one of two or three causes, or all combined. Imperfectly cleaned plates are the most common cause. Some samples of collodion have a predisposition to this defect. Pushing the development or intensifying will sometimes produce it. Besides avoiding these causes, you may prevent it, when the tendency exists, by pouring over the plate, whilst wet, a weak solution of gum arabic or albumen.

M. WYNTER.—On adding carbonate of soda to a silver bath containing acetic acid, acetate of silver is formed. A portion of this remains in solution, but if the acetic acid and soda are present in excess, a precipitate of acetate of silver is thrown down, which is the salt you enclose. It is a difficult thing to eliminate acetic acid from a bath. The only plan we can recommend is to add carbonate of soda until it is neutralized; then let the solution stand in a very cold place for a while, and filter out the precipitate. A portion of acetate of silver will still remain in solution. This may to some extent be got rid of by exposing the bath to sunlight for a few days, by which the acetate of silver will be blackened and thrown down. Again filter, acidify again, if necessary, with dilute nitric acid, and avoid the addition of acetic acid to the silver bath in future.

B. B.—We do not know the specific tone to which you refer, without seeing it. But it is most probably obtained by the acetate bath. Good negatives are essential to good tones, with these, good paper, strong silver solution, and deep printing, you may obtain almost any tone you desire. The tone of your print is not bad, but the negative is hard and not well defined.

H. HIGGINS.—We forwarded the stamps to Dr. Diamond.

PHOTO.—Pinholes arise from many causes, excess of acetate of silver, or of iodide of silver in the bath; dust, turbid collodion, bath, or developer.

T. LEDERSTERN (Cape Town).—Mr. Blanchard will shortly furnish us with a detailed description of his developing box.

T. A.—We will forward the last communication also to Mr. Glaisher. It is a subject we cannot enter into at length in this column.

C. F. LINCOLN.—The two samples of glass are much too light in tint, and would be worthless for the dark-room. A deep orange, approaching scarlet, is the right colour.

REVISED. and will be noticed in our next. "Adjutant or Photographic Art-Studies," Birmingh. "The Universal Text-Book of Photography," Harvey, Reynolds, and Fowler. "A Simple Practical Guide to Photography," by J. Fallowfield, and some other matters.

R. J. K.—To ascertain accurately the amount of angle included by any lens some elaborate mathematical calculations are required. If you have access to a table of sines it may be ascertained more simply. Ascertain the equivalent focus of the lens, and measure the base-line, the angle of subject included is twice the tangent of half the angle. If you are not a mathematician we may aid you in forming an approximation, thus: if the base-line of the picture is the same length as the equivalent focus of the lens, the amount of angle included is about 53°; if the base-line be half the length of the equivalent focus of the lens, the angle included is about 27°, and so in the intermediate proportion, not in definite ratio, but still near enough for a rough calculation. 2. Chloride of calcium and chloride of lime are not the same thing. The latter sold as bleaching powder, is used in toning baths. Its tendency is to give black tones. 3. We do not consider your collodion over-iodized, but in using the iodide of potassium and bromide of cadmium you will be apt to get a precipitate of bromide of potassium.

A. B.—Thirty-six letters for an advertiser with these initials, whose announcement appeared in a recent number of the PHOTOGRAPHIC NEWS, now lie at our office awaiting him.

Several Correspondents in our next.

Photographs Registered during the Past Week.

Mr. JAMES RUSSELL, 65, East Street, Chichester,
Four Photographs of Rev. Dr. Hook, Dean of Chichester.
Mr. JAMES BURKE, 44, Lower Ormond Quay, Dublin,
Photograph of a Plate, described as a specimen of British art.

THE PHOTOGRAPHIC NEWS.

Vol. VII. No. 248. — June 5, 1863.

CONTENTS.

	PAGE		PAGE
Toning Experiments.—Black Tones	265	Correspondence—Foreign Science, &c.....	271
Critical Notices	266	Proceedings of Societies	273
Photographic Chemicals	267	Photographic Notes and Queries	275
Reply to Mr. W. D. Clark. By R. A. S.	268	Miscellaneous	275
Aerial Photography	269	Talk in the Studio	275
Increasing the Sensitiveness of Wet Collodion Plates. By Thomas Sutton, B.A.	269	To Correspondents	276
Heliochromy. By Samuel D. Tillman, M.A.	270	Photographs Registered during the past Week	276

TONING EXPERIMENTS.—BLACK TONES.

The theory of alkaline gold toning remains but very imperfectly understood. Whether it simply consists of a deposition of gold on the surface of the print, or is the result of a substitution process, an atom of gold taking the place of an atom of silver; whether the solution should be just rendered neutral, left faintly acid, or decidedly alkaline; what is the change which is produced by age on solution of gold and some neutral salts; what is the cause of the variety in tint produced by the different agents used in neutralizing or decomposing the chloride of gold—these and some other important questions, depending for their solution upon a satisfactory knowledge of the theory of the process, must remain undecided, until the subject is better understood. We shall probably have something to say on the theory shortly. In the meantime we have a few more words to say on the practice.

It seems to be pretty generally acknowledged that the base of the neutral or alkaline salt added to the chloride of gold does influence the colour of the resulting picture. Whether by regulating the degree of subdivision and size of the particles in which the gold is deposited, or by influencing its mode of combining with the particles of silver in the image; or in some other way, seems to be undecided. But the fact seems to be as generally acknowledged as that the acid in the developer affects the colour of the negative. The acetate of soda and citrate of soda tend to give purple tones; purple-brown if the print be lightly toned, purple-black if the print be deeply toned. The carbonate, phosphate, and biborate of soda have each slightly different effects, more running on the sepia tints. The presence of salts of lime seems to aid in producing pure neutral blacks, such as are familiarly known amongst English portraitists as the French tones. Which class of tones is considered best must depend largely on taste, but as a rule the public demand the black tones, and professional portraitists are therefore fain to produce them, and it is on the production of these tones we now offer a few hints.

We have recently been much interested, during a visit to the Isle of Wight, by examining the results of a very extensive and systematically conducted series of experiments in toning, chiefly conducted with a view to the production of pure black tones, without any red or brown tint on the one hand, or any blue, grey, or slaty tint on the other. These experiments had been conducted in the printing establishment of Mr. Jabez Hughes,* and under his direction, by his son, Mr. Alfred Hughes, and an assistant, Mr. Winterbourne. A general course of operations having been prescribed, each assistant carried out his own experiments independently and without any consultation as to details, or comparison of results until each series was completed. As every photographer knows, a certain formula may work well with a certain sample of paper, but gives

worthless results with another. In these experiments, therefore, a great variety of papers of different qualities, and prepared by different houses, were used, in order that a formula of most universal application, and one which seemed least deranged in its operations by accidental varieties in the paper, might be obtained. The results aimed at were a pure black tone, freedom from mealiness, very little bleaching or reduction in the depth of the print, uniform results on different papers, and a solution which, whilst it would tone soon after mixing, would also keep.

In one series of experiments seventeen different solutions were tried, and ten different samples of paper. In the other series thirteen solutions, and ten samples of paper. Without entering into a precise detail of some hundreds of experiments, we may state broadly their direction, and generalize the results.

Carbonate of soda added to a gold solution in sufficient quantity to neutralize any free acid, nor even in quantity equivalent to the amount of chlorine in the salt of gold, did not, according to expectation, produce a satisfactory toning solution, mealiness being a common result, until at least ten grains of bi-carbonate of soda were added to each grain of chloride of gold, even when the aid of heat was called in to facilitate the necessary reactions, prior to immersing prints. The tones given when carbonate of soda and gold only were present were invariably different tints of brown. The addition of chloride of lime, however, effected a great change and improvement in the character of the solution, black tones were obtained and more regular action. A solution made with from ten to fifteen grains of carbonate of soda, and three grains of chloride of lime to one grain of chloride of gold, in six or eight ounces of hot water, gave very good results. Its keeping qualities were uncertain, but a somewhat remarkable fact was observed, namely, gold solutions containing carbonate of soda, which generally decomposed, became stable when chloride of lime was added.

Chloride of lime alone with the chloride of gold, in any proportion, was found to be unsatisfactory, giving mealy prints when used at once, and not getting into working condition with any amount of keeping which had been tried.

Carbonate of lime and gold alone were not found satisfactory, even when hot water was used. But carbonate of lime, with chloride of lime and gold, gave the best results of all, the toning was moderately rapid, the colour a pure neutral black with warm fleshy half-tones. In this experiment pure carbonate of lime, as sold by the chemist, the same as prepared freshly in the laboratory, by treating common whiting with nitric acid and then precipitating it with carbonate of soda, and also common whiting as sold commercially, were all tried without any perceptible difference in the result. Various proportions were tried, with more or less of success, but the use of excess of the lime salt with hot or boiling water digesting it for about five minutes, and afterwards adding the chloride of lime, was found to be the most efficient method

* We may here remark that the experiments in question were undertaken with the express view of obtaining trustworthy formulæ for a new edition of Mr. Hughes' Manual, shortly to be published.

of getting a bath ready for immediate use. Perhaps the best formula, as deduced from the experiments and confirmed by our own practice, stands thus:—

Chloride of gold	1 grain.
Carbonate of lime from 3 to	6 grains.
Chloride of lime	3 "
Water	6 ounces.

This, if made with hot water, may be used soon after mixing, and will also keep.

Whenever a bath was required for immediate use, it was found that heat was a substitute for time, and a bath which, if made with cold water, might require some hours or even days to attain its proper condition, might, by the aid of boiling water, be made to work well, in a few minutes sometimes, and in an hour or two always. It may be fairly assumed that where heat is used the keeping powers of the bath will be impaired, but we cannot speak with certainty as to this being universally so. A singular point in regard to the keeping of gold solutions may be mentioned, namely, that in solutions which, if mixed and left without using would decompose and precipitate, the gold became stable if used for toning a few prints and then kept. The acetate bath, which is generally stable, was, with the especial sample of the chemicals in hand in Mr. Hughes's establishment, in the habit of decomposing soon after it was made, unless a few prints were toned at once. It then kept perfectly.

The general results we have described are deduced from the whole of each series of experiments, and it is interesting to state that without the slightest collusion or consultation between the experimentalists, the conclusions suggested by each were perfectly in harmony, the lime bath we have described giving the best results in each series, and we have since confirmed it by independent experiment. We may here mention one point in which our own experience is at variance with the results at Ryde, in reference to the proportion of carbonate of soda necessary to produce good results. We found, with the sample of chloride of gold we are using, that with two grains of bi-carbonate of soda and one grain of chloride of gold mixed in six ounces of hot water, and then two grains of chloride of lime added, a bath may be made which gives excellent results within an hour, and does not decompose in the course of a few days.

Our readers will distinctly understand that all remarks here have had reference to black tones. To those who prefer the warm and rosy purples we can recommend nothing which surpasses the bath of acetate of soda and chloride of gold.

One word of caution as to the use of chloride of lime. It must never be used in excess. For whilst the presence of free chlorine is necessary to toning, mealiness is the inevitable result of excess. Wherever silver in a state of fine subdivision is brought in contact with a bath containing either hydrochloric acid or free chlorine, the silver will be attacked, and mealiness will be the result. We feel satisfied that this is the chief cause if not the only cause of mealiness. To be perfectly satisfied, make a strong solution of chloride of lime, and in it immerse an unfixing and untoned print. The experiment is worth trying and will be suggestive and instructive.

Critical Notices.

ADJUTOR. A Monthly publication of Photographic Studies from Nature. Photographed by BRUNELLER and FISCHER. London; L. Birnstingl and Co.

WE welcome this publication with much pleasure as well-intended and giving promise of good execution. Its aim is to extend the usefulness of photography as an aid to art. It is to be a helper, and hence, we presume, its somewhat odd title. An extract from the preface—which is given in English, French, German, and Italian, indicating the universality of its aim—will perhaps best explain the intended scope and purpose.

We wish to furnish artists not with subjects for composition,

but merely with studies from Nature, comprising poses, animals, flowers, prints, landscapes and perspectives. We shall also delineate still life, antique and modern furniture, draperies in different materials, &c.; in short, we have resolved to publish all that photography can represent, which may be useful to the artist, and thus furnish him with a faithful copy of the original under the different aspects of light and shade. If we admit that photography is a faithful agent in the fullest acceptance of the term, it is easy to perceive how valuable our publication will become to the artist, as it will enable him to have at his command different objects, of which he can take advantage either to alter, modify, combine, or even copy, according to his pleasure; or by comparing one study with another, he will be able to introduce whatever may appear most suitable to his subject.

The first number before us contains five studies, the size being about 8 by 6, mounted on plate-paper about 16 by 12, with india-tinted margin. The subjects include two, or rather three, life studies, and two studies of still life. The life studies comprise a fine picture of a graceful girl well posed, and photographed with much delicacy. A male figure, nude from the waist upwards, with a fine head and chest, the arms illustrating great muscular action, the expression being in perfect keeping. This is a very fine photograph—the best of the series. A cow and landscape are a little wanting in vigour. The still-life studies consist of a portion of a drawing-room interior and a group of fish, &c. The photography is generally very good, and the subjects well chosen and arranged with great artistic feeling. In some cases, perhaps more might have been desired of the lenses. In the interior, for instance, we are struck with its fragmentary character compared with those which Mr. Hughes recently obtained of the bridal apartments at Osborne, in which, by the use of a lens embracing a wide angle, portions of three sides of a room are obtained and well defined, without distortion. Altogether, however, *Adjutor* promises well. There is ample room for such a publication, and we shall look for its further successful carrying out with interest.

THE UNIVERSAL TEXT BOOK OF PHOTOGRAPHY.

Instructions, Hints, Formule, and useful information on the various Photographic Processes, &c., with a chapter on the Aesthetics of Photography, from the French of M. DISDERI. Leeds: Harvey, Reynolds, and Fowler.

THIS is rather a text book than a manual for beginners, although it devotes a few pages to preliminary instructions. The aim of the compiler has manifestly been to secure comprehensiveness, almost every branch of photography receiving more or less attention. For the young student we should almost fear an *embarras de richesses* which might bewilder him; the more so that in the aim to include everything, scarcely sufficient care has been given to the construction and arrangement of the book. It is somewhat like a well-filled carpet bag, full of valuable matter, but in a somewhat crushed and mixed condition. Photographers of an experimental turn of mind will revel in such a book, as it is full of varied receipts, many of which are very good. In addition to an immense mass of matter on processes, there is a very interesting chapter on the aesthetics of photography, from the French of M. Disderi, some portion of which we shall, when we have space for the purpose, transfer to our pages. We can recommend the "Universal Text Book of Photography" as an exceedingly cheap shilling's-worth of matter.

A SIMPLE AND PRACTICAL GUIDE TO PHOTOGRAPHY. By JONATHAN FALLOWFIELD; edited by W. HUNT LEE: South London Photographic Depot, Lambeth.

THIS little work appears to be really an introduction to a catalogue of photographic chemicals and apparatus, and consists of less than a score of widely printed pages. The system of adding a few instructive pages to the trade catalogue is

becoming common, and is by no means a bad one, provided it be well done. We regret that we cannot say this much for the little work before us; for, although the matter is pretty well selected, and the plan of the work good, it is not unfrequently disfigured by obscurity, bad grammar, and plagiarism.* Such a passage as the following is downright nonsense:—

It may not here be deemed quite out of place to caution amateurs and others, desirous of obtaining satisfactory results, against the purchase of their materials, &c., at establishments where the exorbitant prices charged, or the numerous adulterations practised, render the efforts of the most careful manipulator worse than useless, and in many cases even the obtaining of a picture a matter of chance, which must always end in failure and disappointment.

In what possible manner can high prices, however undesirable in an economic sense, render the efforts of the manipulator worse than useless?

THE ROYAL YACHT AT THE NORE. Photographed by F. HAES. London: McLean and Haes.

Mr. HAES has sent us a very pretty vignette photograph of the Royal yacht, as she lay at the Nore, all her colours flying, with the Princess Alexandra on board. It is one of the best pictures taken on the occasion, which we have seen, although it lacks the action which gives interest to some of Mr. Blanchard's pictures of the same occasion.

PHOTOGRAPHIC CHEMICALS:

THEIR MANUFACTURE, ADULTERATION, AND ANALYSIS.

Sesquioxide of chromium is not only interesting on account of its being the tinctorial result of a very ingenious photographic process, in which bichromate of potash is reduced by the agency of light, but it is of value to photographers on account of its beautiful colour, which has caused it to be employed as a pigment. There are many ways of preparing this oxide, and as each process gives it in a slightly different physical condition, and therefore of a somewhat different tint, we will briefly describe some of the most approved methods.

Chromate of potash is dissolved in water to form a saturated solution; to this nitrate of suboxide of mercury is added until the precipitate ceases to fall. The liquid is then gently warmed and filtered.

The chromate of mercury is to be well washed and allowed to dry. It is then introduced into a glass retort and gentle heat applied. The hydroscopic water goes off at first and afterwards the salt begins to decompose. Mercury and oxygen gas are given off; the mercury condenses in the receiver, and sesquioxide of chromium is left behind, of a fine green colour. Another way to prepare this oxide is, to prepare a saturated solution of chromate or bichromate of potash and then to add a boiling solution of pentasulphide of potassium, to the boiling liquid, until no more oxide of chromium is precipitated. The reaction in this case is somewhat complicated: the sulphur is oxidized by half the oxygen contained in the chromic acid and is converted into sulphuric acid, which unites with the potash forming sulphate of potash, whilst the sesquioxide of chromium is precipitated. Some persons use pentasulphide of calcium for this process instead of pentasulphide of potassium, and maintain that it gives a brighter coloured oxide of chromium; in the latter case, however, it is liable to be contaminated with sulphate of lime. A third process, which is said to give a green of a peculiarly splendid colour, is the following:—Boil a solution of chromate of potash with sulphur until green oxide of chromium ceases to be precipitated; then filter and wash the chromic oxide till all soluble matter is removed; transfer to a dish or flask and boil in hydrochloric acid until

it has dissolved with formation of a brilliant emerald green solution of sesqui-chloride of chromium. Evaporate this solution to dryness, and ignite in a shallow dish freely exposed to the air. Hydrochloric acid will be driven off, and a beautifully coloured sesquioxide will be left behind.

Lastly, we will give a method proposed by Guignet for preparing a chrome green of a very rich and pure colour. A mixture of three parts of boracic acid and one part of bichromate of potash is calcined at a temperature of about 300° C. An evolution of water and oxygen gas is observed, and there is formed a double borate of sesquioxide of chromium and potash. This salt, which is stable at the ordinary temperature, is decomposed by water giving bichromate of potash and sesquioxide of chromium. The latter body in the nascent state combines with water and forms a hydrated sesquioxide of a remarkably fine colour. This is separated from the bichromate of potash by decantation and washing, and the remaining chrome green is allowed to dry at the ordinary temperature. This pigment is being largely used amongst artists on account of its beauty and brilliancy. The colour is very solid, and it has the valuable property of looking equally beautiful by gas or candle light as it does by daylight—the green colour not changing to blue as is the case with many pigments. Sesquioxide of chromium may also be obtained in a very curious form by the decomposition of bichromate of ammonia. A quantity of crystallized chromic acid is dissolved in water and divided into two equal parts, one portion is then neutralised with ammonia, the other portion added, and the whole evaporated over oil of vitriol. When the solution becomes sufficiently strong, the bichromate of ammonia separates in the form of large cherry-red crystals, which are collected by decantation, drained on bibulous paper, and dried at a gentle heat. On exposing a small portion of this salt to the heat of a spirit lamp in a platinum dish, a very energetic action takes place, accompanied by strong incandescence, and green bulky masses of chromic oxide shoot out in every direction, exactly resembling ordinary dried green tea leaves.

Sesquioxide of chromium possesses another property which renders it of interest to photographers. After it has been ignited it may be considered as being practically unaffected by any chemical reagent. It is, on this account, of the greatest value for colouring paper pulp, from which bank-notes, or important legal documents, are to be made. The green tint of the paper renders them incapable of being copied photographically, whilst the unalterability of the sesquioxide of chromium prevents the paper from being bleached by chemical means before taking the photograph. There is only one objection to paper tinted in this manner. The oxide of chromium is so intensely hard that it rapidly wears away the pens employed for writing on paper tinted with it. We are informed that the best osm-iridium-pointed gold pens become spoilt after being used for a few days in writing signatures on notes made of this paper.

The next metal which demands our notice, by reason of its photographic capabilities, is uranium. This formerly was looked upon as extremely rare, but of late years it has been procured in more abundance, and its salts are now to be met with, at a moderate price, at most operative chemists. The common ore of uranium is the mineral pitchblende. The composition of this is most complicated, for besides the uranium it may contain no less than twenty other elementary bodies, all of which have to be separated by complicated chemical processes. It would be quite out of the question for our readers, unless they possess more extensive chemical knowledge and more complete laboratory arrangements than fall to the lot of photographers generally, to attempt to prepare uranium compounds from the ore direct. The salt usually met with in the shops is the nitrate of uranium, a compound of nitric acid with sesquioxide of uranium crystallized with six atoms of water, the formula being:—

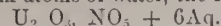

It is prepared by dissolving any oxide of uranium in diluted nitric acid, and evaporating the solution to the crystallizing

* In both the works on photography, we notice in this number, our YEAR BOOK is laid under contribution, in some cases freely, without any acknowledgment.

point. The salt separates in lemon yellow prisms with a tinge of green. It is probable that the proper colour of the crystals is pure yellow, but as this salt, in common with most uranium compounds, is very fluorescent when exposed to light containing much of the chemical rays, it is likely that the blue fluorescent colour, communicated to it in this manner, is the cause of its green tint, by conjunction with its original yellow. The crystals are acid to test paper. They deliquesce in a moist atmosphere, and dissolve in half their weight of cold water, forming a greenish yellow solution. The nitrate also dissolves with great facility in absolute alcohol and in ether. The alcoholic solution, heated to a temperature of 38° C evolves heat spontaneously, boils with the greatest violence, gives off nitrous ether, and deposits a very large quantity of a lemon-yellow powder, which is nearly pure sesquioxide of uranium. When the ethereal solution of nitrate of uranium is exposed to sunlight, nitrous ether is produced, a large quantity of the same yellow powder is produced, and there remains an aqueous solution coloured green by the presence of a lower oxide of uranium. When nitrate of uranium is heated, it melts in its own water of crystallization, gives off water and acid, and acquires a reddish yellow colour. When it is fused at a gentle heat, till the greater portion of the water is driven off a yellow liquid remains, which, on cooling, solidifies to transparent prisms. Upon exposure to the air, these rapidly absorb water, and lose their transparency.

REPLY TO MR. W. D. CLARK.

BY R. A. S.

MR. CLARK commences his paper with a complaint. "The discussion 'On Photography as a Fine Art,' has been conducted with too great a display of temper." I rather think Mr. Clark has mistaken for temper what impartial observers would characterize as simple earnestness and enthusiasm. I am not aware of any ease in which the advocates of photography, either as a fine, or, as a mechanical art, have overstepped the bounds of legitimate and logical discussion, unless indeed, Mr. Clark's own paper may be considered an exception, or Mr. Sutton's recent attack upon Mr. Rejlander can be so regarded; on which points however, lest I should offend, I will not venture to give an opinion.

Photography "looked upon as an intellectual pursuit is far inferior to that noble art," painting, because it is "entirely devoid of the beauty and expression to be got from the use of colour." Thus runs Mr. Clark's argument, No. 1. But what has this to do with photography as a fine art? Are Turner's monochrome sketches, Hogarth's engravings, Raphael's ink studies, and all those numerous works without colour, which are the pride of our museums and fine art collections, to be swept down from the lofty position awarded them by generations of artists and critics, because they "are entirely devoid of the beauty and expression to be got from the use of colour?" Argument No. 1 will not hold water, Mr. Clark.

"But this is not the chief disadvantage under which photography labours," says Mr. Clark, for the photographer cannot give expression to his subject, be it model or landscape, or, in other words, cannot convey "his own feelings and emotions" through the agency of his productions. Now, what can a lover of art-photography, who is familiar with the productions of Wilson, Bedford, Lake Price, Rejlander, &c., say to such an argument as this? He may point out the poetic grandeur and the romantic sentiments with which this, or that glorious photograph is overflowing, and he may turn over a folio of Rejlander's exquisite productions, in which the very expression, pose, chiaroscuro and sentiments of figures in the works of the best masters are faithfully reproduced from living models. He may bring forward these as unanswerable arguments, but what avails it if his prejudiced opponent only elenches his eyelids tightly over his spectacled optics, and says emphatically, "I can't see it, my dear sir, it's nothing but your imagination, I assure you." Has Mr. Clark seen these

productions? if not, before he writes another line against art-photography, let him do so. What better argument is there against the alleged impossibility of doing this or that, than the demonstrated fact of its having been already done. As to Rejlander's "Two Ways of Life," in which Mr. Clark could see nothing but mechanical "ingenuity," and before which he could do nothing but "wonder what it all meant," let him turn to the last number but one of the *British Journal*, and see what Mr. George Harvey, an artist of the highest repute, thought of this identical work.

Photography is not a fine art because it is not difficult of attainment. This is the novel test by which Mr. Clark discovers, in some mysterious way, whether an art may be called fine or not, and which test seems to have been originated by the writer having become mentally confused, and so thinking that arts which are attained with difficulty are more intellectual than arts which are attained more easily. The earliest sketch of a great master may have possessed more intellectual power and loftier art than the latest and most elaborately finished production of an inferior artist, whose long life had been one of ever-patient and earnest toil and drudgery. Shall we then say because the great master attained his art easily, and the inferior artist attained it with difficulty, that therefore the last was the greater? It is of no use for Mr. Clark to urge that photography is as easily acquired by great as by little masters, and that therefore, &c., &c. The test, the test's the thing, and that is clearly a failure.

The small angle of view and the other imperfections of lenses are next advanced as arguments against the claims of photography as a fine art. In reply to the angle of view argument, there is Sutton's panoramic lens, and Harrison's new globe lens; with regard to other imperfections Mr. Clark shall himself reply. In the exhibition of the Scottish Academy there are certain paintings held up by Mr. Clark as specimens of real fine art, one of which this gentleman describes as being "as true to the locality as any photograph." Well and good—if the painting be as true as the photograph, it follows that the photograph is as true as the painting, and if the photograph is not true enough to justify its claims as the production of a fine art, what is the painting, Mr. Clark?

"The irritability exhibited by photographers whilst urging the claims of their art to be included amongst the fine arts," is Mr. Clark's next argument as evidence of "a lingering suspicion that their cause is not a very strong one." Alas! for all sufferers from injustice, if the expression of natural indignation in the natural way is to be twisted and construed into a proof of having deserved ill treatment. When I am insulted I obey an impulse of my nature in warmly resenting it; am I to suppose that Mr. Clark would quietly pocket the same by way of proving his cause against the insulter "a very strong one." It is with me a subject of hopeful congratulation to know that photographers have sufficient respect for their infant art to resent an insult from those who would degrade and injure it in public esteem, warmly and enthusiastically.

At this stage of his progress Mr. Clark breaks off to diverge into a perfectly uncalled for and out of place attack upon the periodical literature devoted to photography in general, and the *British Journal* in particular, by which it appears that Mr. Clark may belong to a class by which joking is considered as sheer vulgarity, and cheerful laughter as a proof of downright ill-breeding. The mouths of our literary organs ought, perhaps, to be continually twisted into the "prunes and prisms" propriety of which Dickens has given us so vivid a picture in "Little Dorrit."

Returning to his subject, Mr. Clark thinks, after all, that although photography cannot rival, it may serve art, and also admits that no sketch can be so true to nature as certain photographs (taken by the aforesaid imperfect lenses) are. It is also admitted that "the exquisite detail that a photographer can obtain," in vegetation, &c., "no amount of care or finish will enable the artist to get."

Again, it is admitted that "photography is obviously doing good service to painting by educating the public eye to the beauty of simply an accurate copy of nature." But truthfulness, and beauty, and perfection of detail, are all as nothing in the eyes of Mr. Clark when considered as part and parcel of photography's claim to be considered a fine art. Photography is more truthful than Turner, says Mr. Clark, and the works of a fine art becoming through its influence more truthful, are thereby improved. Painting is to be tested by the standard of photography, says Mr. Clark, but the standard is decidedly inferior, and a long way below the thing tested thereby. Is all this quite logical, and does Mr. Clark really believe in the justice of his own cause?

AERIAL PHOTOGRAPHY.

For strategical purposes in time of war, and for the advancement of science in the nobler interests of peace, the balloon has proved serviceable; and the value of photography has now been tested conjointly with that of aerostation. Mr. H. Negretti, a partner in the well-known firm of Negretti and Zambra, the scientific instrument makers to the Admiralty, has performed some interesting experiments with the photographic camera in the car of a balloon. The pictures which he has succeeded in taking, at elevations ranging between 3,000 and 6,000 feet from the earth, are not, as may be imagined, perfect specimens of the art which he has helped in bringing to so fine a state of development on solid ground; but, considering the tentative character of his efforts, enough has certainly been accomplished to demonstrate the practicability of obtaining very good photographs of terrestrial objects at a height even greater than that which we have named as the maximum of his recent trials. Mr. Negretti, piloted by the experienced Mr. Coxwell, and attended by an assistant on whose ability he could rely, made his ascent from the Bell Green Gas Works, near Sydenham. The car of the mammoth balloon was fitted up as a dark room, and preparations for operating by the wet collodion process was made. It was not till an elevation of 4,000 feet had been attained that the rotary motion of the car ceased, or abated sufficiently to enable Mr. Negretti to expose the prepared glass plate. This was an anxious moment, for on the result of the first application of the developing fluid would depend the knowledge whether or not the actinism of the higher atmosphere was favourable to the operations of the photographer. The assistant soon dispelled this unpleasant doubt by announcing that the picture had "moved," or, in less technical phrase, that the image on the plate was ill-defined by reason of the unsteadiness of the lens. That there was an image, however, quite satisfied Mr. Negretti, who gave quick directions for the preparation of another plate. The second showed little or no improvement on the first; nor did a third or fourth bring any change in the assistant's gloomy iteration, "Moved." As the views were all taken instantaneously, it seemed difficult to account for the want of precision; and, on entering a stratum of cloud, the enterprising experimentalist was left to ponder the causes of the interruption to his complete success. On descending into clear atmosphere again—much clearer, indeed, than had been previously found—the attempts were renewed with better effect, and at last some tolerable pictures appeared on the filmy surface of the plate. The net result of Mr. Negretti's aerial essay is, as we have said, an establishment of the fact that photography is just as feasible an idea 5,000 feet above the level of the sea as in a commodious glass house in Regent Street or the Champs Elysées. The beautiful valley of the Medway has not been flattered by its *cartes de visite*, taken in the car of the mammoth balloon; but, on another sitting, its fair face may possibly "come out" more truthfully charming in the novel exposition of its loveliness.—*Télégraph*.

INCREASING THE SENSITIVENESS OF WET COLLODION PLATES.

BY THOMAS SUTTON, B.A.

[We extract from the last number of the *Photographic Notes* the following interesting paper. We have not had time to repeat the experiments, but as the subject is important, we place the matter at once before our readers for trial, and shall be glad to learn the results.—Ed.]

One of the directions in which photographers most anxiously look for advance in their art, is that of obtaining increased sensitiveness of negative plates and positive papers; our readers will therefore hail with pleasure the announcement that we have discovered a very simple means of exalting the sensitiveness of wet collodion plates, and at the same time introducing some other advantages. The method can be very simply stated, and very easily tried. It consists in first washing the excited plate thoroughly in distilled water,—or, which is the same thing, immersing it in a bath of distilled water,—and then re-dipping it in the nitrate bath; after which you proceed as usual. By adopting this modification of the common practice you increase the sensitiveness of the plate from fifty to a hundred per cent., and obtain a softer and more harmonious negative, with fewer pinholes and other common defects.

It will be interesting to discuss the *rationale* of this washing and re-dipping operation, as well as some other experiments which bear upon it.

If you take a collodion plate from the nitrate bath, wash it with water, expose it in the camera, and then attempt to develop the image in the usual way, you first find that it is absolutely necessary to add silver to the developer, in order to obtain a dense negative; and, secondly, that the sensitiveness of the plate is reduced, according to the amount of washing which it has received. This is the general statement of what happens to a washed plate exposed wet. You cannot *entirely* destroy its sensitiveness by *any* amount of washing, because you cannot entirely wash out all the free nitrate of silver; but by excessive washing, and exposing it wet, you can greatly reduce its sensitiveness, and render it almost impossible afterwards to get a good dense negative by any method of development. The presence of free nitrate of silver in certain quantity, in contact with the iodide or bromide of silver, is absolutely necessary, in order to get the most exalted sensitiveness of the plate. Again, if you take a thoroughly washed plate and endeavour to exalt its sensitiveness by applying to it any of the known preservatives, you fail in obtaining a satisfactory result if you expose the plate wet. The film must be allowed to become thoroughly dry before the plate is exposed, or it is next to impossible to get a good result. Of course, as the plate gets dry, the minute trace of nitrate of silver which it has obstinately retained, in spite of the washing, becomes concentrated, and in that state there may even remain enough in contact with the bromo-iodide of silver to render the dry washed plate as sensitive as the original unwashed wet plate. But this exalted sensitiveness which some dry plates possess depends upon their being quite dry, and is not observed in the same plates if exposed wet, or even damp. Everyone who has practised the dry process knows what a miserable result is obtained upon any part of a plate which has not become thoroughly dry, while the remaining part of the plate which is dry may yield a fine negative. The result is as true of bromo-iodized as of iodized collodion, and it proves that a certain quantity of nitrate of silver in contact with the iodide or bromo-iodide is necessary in order to obtain the highest degree of sensitiveness, and that the presence of bromide of silver alone does not *entirely* compensate for the removal of the free nitrate, as some people suppose.

Such are the observed facts as to the washing and drying of excited collodion plates, whether simply iodized or bromo-iodized. We now come to a new class of experiments, which consist in redipping in the nitrate bath a washed collodion plate before exposure; and this is found to render its

sensitiveness greater than it was at first, without introducing any practical objections. Moreover, the effect seems to be even greater and more decided with a bromo-iodized than with a simply iodized film. On considering this circumstance attentively we arrive at the following explanation of these facts:—

In the first place, there exists in the film, on its removal from the nitrate bath, a quantity of nitrate of potass, or cadmium, or ammonium, which no doubt, by its mere presence, acts mechanically in interrupting the chemical changes which occur during the exposure to light, even supposing that it does not act injuriously in any other way. This nitrate is removed by washing. Then again there may exist in the film some undecomposed iodide of potassium, or cadmium, which would be removed by washing, and the presence of which, in an unwashed plate, could hardly fail to affect the sensitiveness considerably. It is well known that a plate which has not been allowed to remain long enough in the bath is less sensitive than one which has remained the right time in it. And lastly, in the case of a bromo-iodized film, there is always a considerable quantity of undecomposed bromide of cadmium, or ammonium, in an unwashed plate, because, instead of minutes, it takes hours to convert the whole of this into bromide of silver.* We are the first to publish this strange fact, and although it was disputed at the time by some authorities, yet we observe that Major Russell, for one, has lately recognised it, for he directs his new bromized plates to be excited in a sixty-grain new nitrate bath, and left twenty minutes in it. Such treatment would be ruinous to an iodized film. Now all the undecomposed bromide of cadmium, in an unwashed bromo-iodized film, which has only been a few minutes in the bath, must surely interfere greatly with its sensitiveness, but it is removed by washing or soaking the plate in a bath of distilled water.†

Such are some of the reasons why washing and redipping the plate ought theoretically to render it more sensitive, and experiment proves that the treatment does so, and a very important result that is.

Another advantage of the treatment is, that it causes the developer to flow more freely upon the plate. The collodion film has naturally a repulsion for water, which is shown by the greasy streaks formed upon its surface when first dipped in the nitrate bath. This repulsion does not exist in consequence of the presence of ether in the film, because the same effect occurs when alcoholene is used instead of collodion, in which there is no ether present. Moreover, this repulsion is greater for water than it is for a strong saline solution like the nitrate bath. Thus it happens, that after all the greasy streaks have disappeared from the film on its removal from the nitrate bath, they reappear on immersing it in the bath of distilled water, and the plate has to remain some minutes in the water before they disappear again, when the water has permeated the film. Thus, after the plate has been redipped in the nitrate bath and exposed, the developer flows more easily upon it than if it had not been already permeated by water in the water bath.

It appears also that there are fewer pinholes and comets in a washed plate than in one which is exposed in the usual way without having been washed.

It only now remains to consider whether there are any practical inconveniences to put as a set off to the advantages gained by the additional operations of washing and redipping. But so far from there being any disadvantages, it appears to us that a great practical convenience may

* We must here interpose a comment. It is, of course, difficult to decide the exact point of time at which the whole of the bromide in a film is converted into bromide of silver; but all our experience goes to prove that although the decomposition takes place more slowly with a bromide than with an iodide, it is still a question of minutes not of hours. If it were otherwise the gradual increase of delicacy, softness, cleanliness, and, in some cases, rapidity, which is found with increased proportions of a bromide, would not, with an immersion of five minutes be perceptible as we have often found them.—ED. PHOTOGRAPHIC NEWS.

† We presume a fresh, unused bath is intended, otherwise the bath would contain portions of the nitrates here intended to be eliminated.—ED. PHOTOGRAPHIC NEWS.

arise from the plan recommended. Thus a photographer in large practice may clean and excite a number of plates in advance, ready for use as his sitters come in, and may keep them immersed in the water bath for hours until they are wanted; and when the time comes for using them, all he will have to do is to take them out of the water, drain them, dip them in a clean filtered nitrate bath, and put them into the dark slide. The time lost in coating and exciting plates whilst the sitter is waiting will thus be avoided, as well as the time lost in coating and exciting plates which are not exposed owing to defects in the film.

We sincerely hope that many of our readers will give this washing and redipping a fair trial. During the years which have elapsed since the original publication, by Mr. Archer, of the wet collodion process, no important modification of his original directions or proportions has been introduced. This is the first proposed change in the manipulation of that process which seems likely to be attended with solid advantage, in several ways, but more particularly in the increase of sensitiveness which it confers.*

The quality of negative is rather improved by the treatment, the contrasts being somewhat reduced, and more softness, harmony, and delicacy of detail obtained. With respect to the time which should be allowed for the plate to remain a second time in the nitrate bath, it should be remembered that the pores of the film are filled with water when it is first immersed, and time must be allowed for the nitrate solution to displace this water, or sensitiveness and density will not be obtained. On the other hand, if the film is left too long in the bath, the iodide of silver will be attacked. About half a minute will be found a good average time for the second immersion, or possibly less.

We shall be very glad to hear what success our readers have in trying the plan recommended in this article, and whether their experience confirms our own results. Should it do so our suggestions will have considerable practical importance. We would caution them, however, on this, and all occasions, to remember that in photography a single experiment proves very little, and that the results of such an experiment require to be confirmed again and again before they can be relied on. One of the evils attendant on photographic journalism has been, that persons are too ready to rush into print, and describe results which they have obtained, on the faith either of isolated or of too small a number of experiments. Many good processes have thus been condemned, and bad ones recommended, on the faith of a single trial.

HELIOCHROMY.

BY SAMUEL D. TILLMAN, M.A.†

TECHNOLOGY has its enthusiasts who are constantly claiming for it more than can ever be accomplished; they do not clearly perceive the line which limits the practicable. The actual success and great achievements of art afford them too much stimulus, and their imaginations seem to receive a momentum thereby which the judgment cannot check. The barriers disclosed on every side by test and practice present no impediment to their visionary advances. Having leaped over all obstacles to a satisfactory conclusion regarding some grand improvement, they receive with implicit faith every statement which tends to confirm it.

A few years ago the world was startled by a voice from the Highlands of the Hudson, announcing the discovery of a process by which light was made to give a permanent picture of any object in its true colours. Hardly had this voice been silenced when another was heard in a different direction; similar announcements have been made periodically up to the present time. The gentleman who has last

* Some years ago we made some experiments in a similar direction for the purpose of improving the character of collodion positives. Our plan was to use a very dilute second bath to lessen the amount of free nitrate left for surface reduction. We did not then notice any increase of sensitiveness; but we did not look for any.—ED. PHOTOGRAPHIC NEWS.

† Read before the American Photographical Society, April 13th, 1863.

agitated us on this subject is M. Niepce de St. Victor, whose reputation certainly entitles him to a hearing. He gravely states that he has succeeded in obtaining a pure and permanent black and white, with colours which were evanescent. Without questioning the correctness of this statement, or attempting here to account for the phenomena observed upon the principle of sympathetic molecular vibrations, it is safe to assert that the real problem is as far as ever from a satisfactory solution. It seems proper that practical photographers should have a clear comprehension of the proposed improvement and the difficulties attending all attempts to give it permanence. A few succinct statements may elucidate the subject.

1st. The action of light is through an undulating ethereal medium which produces three distinct kinds of effects, viz., colorific, calorific, and actinic.

2nd. The colorific effect resulting from the action of a single octave of waves, probably depends upon the harmonic relations arising from the ratio of the velocities of these waves. These waves produce the picture visible to the eye in the camera, but have little or no influence in producing the invisible effects made upon the prepared plate.

3rd. The waves of higher velocity possess actinic power, which is graduated by the sun of light sent from every point of the object to be copied.

4th. It is obvious that the actinic rays being the chief, if not the sole cause of chemical change, must impart their own characteristics to the chemical preparation to the exclusion of those belonging to colorific action.

5th. The ratios of velocities of waves exciting the impression of color are generally lost the instant these waves impinge upon the plate, as the ratio of falling drops of water disappear when the drops are commingled. Yet should the atoms of the sensitive film take up the vibratory motion of the impinging waves, the action could not be of long duration, because the same kind of matter cannot have various rates of vibration, each normal and lasting.

6th. Besides a change in molecular motion, we may imagine a change in the position and arrangement of molecules, so as to present a thin lamina, which may have the effect of decomposing light and sending out such delicate tints as come from the shell of the pearl oyster. It is possible that this mechanical change might be quite as permanent as the chemical change produced by the actinic rays; yet who has proved by experiment that æth-waves have the power of aggregating and dispersing molecules or atoms?

7th. The chemical changes produced by light can differ only in *degree*, owing to the homogeneity of the substance covering the prepared plate; and in this view of the case the scientist is safe in asserting that the colours of nature cannot be imitated, until we have more perfectly under our control the materials with which she works. Thus far, the few elements she uses in producing the gorgeous colours found in the vegetable kingdom have refused to acknowledge any other master. These colours are not superficial; they are the result of internal structure. The gradual and systematic arrangement of cells belongs alone to the power of growth. When man can weave atoms at his will, and combine elementary substances in ways which chemistry thus far has failed to do, he may construct the groundwork for a chromatic exhibition. But to prepare a surface with any of the compounds now known to the chemist, which will give back the whole gamut of permanent colours, is a proposition that should not be seriously entertained.

Correspondence.

FOREIGN SCIENCE.

[FROM OUR SPECIAL CORRESPONDENT.]

Paris, June 3rd, 1863.

DR. VAN MONCKHOVEN, experimenting upon formic acid in developers, both sulphate of iron and pyrogallic acid, states the result to be as follows:—Sulphate of iron develops the

negative more quickly than pyrogallic acid, whether the latter has acetic or formic acid added to it. It admits also of an exposure, one-third shorter, in the camera.

Pyrogallic acid, with formic acid added to it, makes the image appear quicker than with acetic acid; but formic acid, reducing the silver from its nitrate without, however, concurring in making the image appear, fogging often results. Although the addition of formic acid, in the place of acetic acid, develops the picture in less time, the exposure in the camera cannot be diminished. Thus, it appears that Mr. Claudet's formula does not possess the advantages he claims for it. On the other hand, Mr. Claudet assumes that the acid employed by Dr. Van Monckhoven was too concentrated. Possibly it was so. But as Mr. Claudet has not indicated the degree of concentration of the formic acid he employed, while Dr. Van Monckhoven, in the account of his experiments, took that precaution, the latter intends to repeat them, although he finds it difficult to admit that by diminishing the proportions of formic acid the exposure in the camera can be shortened.

With reference to the composition of the positive image on paper, Dr. Schnauss has stated that non-albumenized positive paper simply toned with chloride of gold, *either before or after fixing*, contains gold only, without appreciable traces of silver. But Dr. Van Monckhoven formally disputes this conclusion, at least, so far as relates to the words in italics. He maintains that only gold remains in the proof when it is toned *before* fixing, but silver remains *in the state of chloride*, if the picture is toned *after* fixing. This fact is explained in the following manner:—

The image, upon paper simply salted, is composed for the most part of metallic silver. Immersed in the chloride of gold, one portion of the gold is precipitated upon the silver, while the chlorine of the chloride of gold combines with the silver, and forms white chloride of silver and violet chloride of silver. If, however, the chloride of gold acts for a long time, this violet chloride itself takes more chlorine and passes to the state of white chloride. Then the hyposulphite, acting upon it, leaves only the gold.

But, on the other hand, the image first fixed, it is then wholly constituted by metallic silver, the chloride of gold acts in the same manner, and chlorides of silver and of gold are found in the proof. If, therefore, we do not have recourse to a second fixing, silver in the state of chloride remains in the proof. With albumenized paper, the reactions are more complex. It must not be forgotten that in this case we operate with chloride of gold only, and not with the alkaline gold baths usually employed.

Some of our photographers are busily occupied in producing the photographic postage stamp. Cameras and objects are specially constructed for this purpose, by which four-and-twenty pictures are taken at one operation.

Positives taken upon plain paper generally possess less brilliancy than those taken upon albumenized paper. It is not sufficient for the paper to contain chloride of silver with excess of nitrate; to obtain brilliant pictures, there must also be present an organic substance, capable of combining chemically with the nitrate of silver, just as the albumen does. The substances which accomplish this object, more or less, are gelatine, arrowroot, resin, gutta percha, caoutchouc, sugar of gelatine, decomposed nitro-glucose, &c. Very good results are obtained by immersing the positive papers for a few moments in a warm solution of gutta percha, or caoutchouc in chloroform and benzine, and when dried, salting them in a solution of an alkaline chloride. Sensitizing, and the other operations, are performed in the usual manner. The pictures thus obtained are, it is true, less brilliant than those with albumenized paper, but on the other hand, the paper is more reliable for use. In any case, the picture is infinitely more brilliant than with ordinary salted papers.

M. Testelin's article on developing and strengthening with sulphate of iron, inserted in No. 239 of the PHOTOGRAPHIC NEWS, is very complete and instructive; and in our present

state of knowledge respecting reduction, very little is required to render this kind of review of the processes employed perfect. The writer has noticed all the good methods of reduction, easy to follow, and giving remarkable results. Still, however, we find that he has not sufficiently recommended strengthening with sulphate of iron; therefore, we will describe yet another method preferable to the old one, which consists in continuing the reduction by means of pyrogallic acid.

The negative, as soon as possible after exposure, is developed by pouring on to it the sulphate as *slowly* as possible, without dividing or breaking up the stream. The surface must be covered with a light, but continuous layer, taking care to employ only a *small quantity of the liquid*, just sufficient to cover the plate with a slight excess. If the operator contracts the habit of pouring on the iron solution very slowly he may reckon upon a *diminution of the time of exposure equal to one-fifth of the whole*. The negative is slightly washed, then covered with a solution of nitrate of silver of the strength of 2 to 3 per cent: the operation is performed in the same way as collodionizing a plate. The excess is collected, then the iron solution is again poured on in the same way as described for the silver solution. If, after this second operation, the negative is not completed, we proceed to a third, and even to a fourth, until it attains the desired vigour.

It will be remarked that the negative being of a grey colour will not appear so opaque as those developed with pyrogallic acid. But this colour may be changed at the will of the operator by employing, in the last place, sulphate of iron with gallic acid, a bath which is rendered colourless by nitric acid. We may limit ourselves to passing the negative into a *very weak* solution of *bichloride* of mercury. It has become the fashion of late to deery the use of this latter substance on account of its causing opacity in the picture and liability to fade, but five years' experience have never shown us these objectionable results. Employed in a concentrated solution the bichloride acts in the same manner as a strong dose of pyrogallic acid in presence of nitrate of silver, by rendering the image opaque, but in a weak solution the bichloride blackens the image without being accompanied with this inconvenience.

In fine, strengthening with the sulphate of iron indicated above, is made with rapidity and certainty. It gives better results with portraits than pyrogallic acid yields, and its employment is free from the risk of failure.

The quantity of sulphate of iron composing the bath has little or no influence upon the final result when the quantity of acetic acid is in direct ratio with the sulphate. If it is from 5 to 10 per cent, there must be at least 2 to 4 per cent. of acetic acid. If the quantity of sulphate reaches 15 to 20 per cent, there must be 6 to 9 per cent, to produce the same effect.

When the bath is employed several days in succession, it is preferable to add from 1 to 2 per cent. of acetic acid, in order to re-establish it from day to day in its primitive condition.

In the proportions of 1 per cent of sulphate to 2 per cent. of acetic acid, we obtain an iron bath very nearly the same in its action as pyrogallic acid.

Some operators add a quantity of alcohol to the bath in order to equalize the difference of density between the liquids. Possibly, they may obtain a good result, but veins of a greasy aspect multiply upon the collodion film, the reduction becomes unequal, and failure is a very frequent consequence.

In practice, the following maxims are of very great importance:—

1st. That a negative developed an hour after exposure has lost much of its sensibility.

2nd. That in pouring the sulphate on slowly we obtain a negative with an amount of exposure which would only have yielded a positive, if the liquid were in large quantity and poured on rapidly.

3rd. That when we cover the film with the solution of nitrate, we strengthen the picture more quickly and with less silver than if, at several repetitions, it had been added to a portion of the iron bath.

4th. That a very weak solution of bichloride absolutely presents no inconvenience.

MR. CLARK AND PHOTOGRAPHY AS A FINE ART.

DEAR SIR,—In the NEWS of last week appears a paper read by Mr. W. D. Clark, before the Photographic Society of Scotland, entitled "Photography as a Fine Art." It seems to me that the effect of this paper, if uncontradicted in regard to many of its details, would be to convey very erroneous ideas of the present position, and probable future, of photography.

Not having the advantage of the personal acquaintance of the writer of this paper, and being quite unacquainted with his name, either as a photographer or a painter, I shall be excused from all animus in calling attention to some of his assertions.

Mr. Clark commences by drawing attention to the inferiority of photography to painting. Having yet to learn that the opposite has been asserted by any writer of authority, it may be assumed that it is a controversy of Mr. Clark's creation—a statement made in order to be denied. Photography and painting base their claims to support on entirely distinct grounds. They are the offspring of minds having totally different objects in view. I am inclined to think that, with Mr. Clark, familiarity has bred contempt; the fact of the enormous demand for photographs causing every shop to be filled with them. But let us for a moment suppose that one of these cartes de visite, of which Mr. Clark speaks so slightly, required months of labour to produce, and could then only exist as one single picture, without the power of reproduction, I feel certain that in such a case it would be pronounced the masterpiece of the most inventive age ever known.

Mr. Clark invites comparison between photographs and paintings; let us, therefore, examine a little into the question. The most immediately lucrative branch, both of painting and photography, is portraiture, and as there is just now a large demand, it is a matter worth consideration. Two exhibitions, one of photographs, and one of paintings, (the Royal Academy) have been opened this year within a few hundred yards of one another, and a very large number of persons must have visited both. I have most carefully analysed the manner of treatment employed by artists whose portrait paintings are now suspended in Trafalgar Square, and confess my strong belief that taking them, as a whole, neither the pose, accessories, nor yet the very point on which Mr. Clark relies most—the expression—are by any means equal to photographs of high class. Again, Mr. Clark exultingly declares that photographs have no power to "tell a story or appeal to the feelings." How then about Mr. Robinson's "Bringing Home the May?" I defy any unprejudiced person to assert that there is not in this picture the most exquisite "story" of rustic life, or to state it does not appeal to the feelings in the strongest and most forcible manner. Again, Lady Hawarden's studies are direct contradictions of Mr. Clark. In another branch, let us take the pictures of moving life by Mr. England and Mr. Breese. Surely that person must be wanting in every sentiment of beauty who can assert that these do not illustrate, in a manner never before dreamed of, the writings of poets in all ages. Few, very few, I am convinced, can look on these magical views of cloud, sea, and sunshine, without recalling our national "Rule Britannia," and an exclamation of delight at the exquisite beauty of the result. Painters may colour their brightest, and pre-Raphaelites may draw each blade of grass and every leaf with painful correctness, but I cannot allow that these photographs are produced by any other than a high feeling of reverence for the beauties of

nature. They most aptly illustrate many a line of poetry which is oftentimes offered at exhibitions.

One cannot be surprised that many painters should be found to deery the new art that has destroyed the practice of all second and third rate artists, whatever may be Mr. Clark's opinion. Mr. Clark says, "The world generally estimates the value of any pursuit in proportion to the intellectual effort employed in it." If this be the case, I am unable to see why photography should come off second best. I absolutely deny Mr. Clark's statements about the facility with which photographic excellence is acquired. On the contrary, it takes the experience of years to become anything like proficient. Let Mr. Clark take a few names of those who do the best pictures, and he will find that, without exception, they have been a considerable number of years. Of course, all know that certain results can be produced at first starting, but cannot the painter also do this? and shall we say that one and not the other can be learnt in a very short time? Mr. Clark is singularly unfortunate in his comparison of the pictures of the Holy Land and Egypt. The very same occurrence has happened in my presence that he describes, and where the result was totally different. Those who had travelled in the East immediately relinquishing Mr. Roberts's lovely pictures in favour of Mr. Frith's photographs. Mr. Clark says, "In figure subjects, photography can only copy, it cannot invent." This proposition appears like a formal denial that a photographer can be an artist in the true sense of the term. What is there to prevent a photographer arranging his models with as much skill as a painter? Of course the camera cannot invent, but, surely, he who uses it can.

Those painters and sculptors who are alive to their own best interests, use photography largely. A group now in the Royal Academy has absolutely the same positions, accessories, and expressions on the face as the photographer secured, although the painter was not even present. Mr. W. D. Clark's erratic and exceedingly crude remarks should be a caution to those who consider themselves qualified to act as a "guide, philosopher, or friend" to the artistic world in general, and photographers in particular.

SAMUEL FRY.

83, Gracechurch Street, E.C.

MR. BROOKES ON THE ACTION OF THE BLUE RAY.

DEAR SIR,—There were two points in the paper I read last Tuesday before the Photographic Society of London, upon which I seemed to be misunderstood. During the preparation of that paper, one of the knuckles of my right hand was so inflamed that I could not hold a pen, and had to obtain the assistance of a second person to copy from my rough jottings down. This copy I had not time to alter, and, whilst reading it before the meeting, discovered, besides numerous mistakes, whole pages left out.

The first mistake I wish to correct is in regard to that portion relating to "Ether." The impression I wished to convey was, that as phosphorus held in solution by ether decomposes the iodide film when only the *invisible fumes* reach its surface, so that element held *invisible* in the atmosphere likewise decomposes the iodide film when brought in contact with the rays of solar light.

Secondly, in respect to "*Phosphorus and Phosphorescence*:"—I am well aware that the latter term is applied to that light, which organic and inorganic bodies have the power of emitting after insulation to solar light. If I were understood to imply that this light is *phosphorus*, it was owing to my unfortunate lack of the ability of expressing my thoughts and ideas by speech. The following is what I meant:—That silver, whether in combination with iodine, chlorine, or bromine (and not simply these, but other bodies also), induce phosphorescence from light. (It matters not whether this is termed "*invisible phosphorescence*"); but, in this case, instead of giving back the light it has received from the sun, as in the *Bologna stone* and other phosphorescent bodies, enters into combination with the iodine or the silver. For the fumes or vapour of phosphorus being the slow combustion of that element in contact with the oxygen of the atmo-

sphere, and this vapour decomposing iodide of silver, which, according to Mr. Malone's statement, forms phosphate of silver; so the decomposition effected by phosphorescent rays of solar light upon iodide of silver, *may be*, identical to the similar displacement caused by the phosphorescent rays emitted by ordinary phosphorus.

It was this I wished to explain both by the paper and verbally; in endeavouring to do so by the latter means, I know "*I jumped from the frying-pan into the fire*;" and until I can read the paper in print, I cannot tell to what extent I was misunderstood, as I have no copy in my possession to refer to; but the above is what I still believe to be the cause of the decomposition of the iodide film, &c., and I hope, at some future period, to be able to prove such to be the fact by evident experiments.

Apologizing for occupying your valuable space with what ought to have been distinctly explained by me at the time, I am, dear sir, yours truly,

E. T. BROOKS.

Newbury, June 3rd, 1863.

Proceedings of Societies.

LONDON PHOTOGRAPHIC SOCIETY.

THE last meeting before the recess of the Society was held at King's College, on the evening of Tuesday, the 2nd inst., Mr. C. B. Vignoles, F.R.S., in the Chair.

The minutes of a previous meeting having been read and confirmed, Mr. Mason, of Blackheath, was elected a member of the Society.

The SECRETARY read a letter from Mr. Ross calling attention to a portfolio of photographs which accompanied it. They were taken with his triple lens; some with a lens of 8½ inches back focus intended to cover 8 by 4½, were taken on 12 by 10 plates: others on the same sized plates taken with the lens intended for 10 by 8 plates, the focus being 15 inches. He also sent a brilliant, well defined negative taken with a new portrait lens for medallion pictures, the focus being 1¼ inches and the diameter ⅝ths of an inch.

The SECRETARY also read a letter from Mr. Dallmeyer calling attention to a magnificent copying camera and equipment for plates 18 by 18, which he had just completed for the Italian Government. Also to some interiors of the bridal apartments at Osborne by Mr. Hughes, taken with his No. 1 triple, of 8 inches equivalent focus, on plates 10 inches square; and to some portraits of different members of the Royal Family, taken at Windsor with his No. 2 card lens, by Mr. Mayall.

The SECRETARY then explained that Mr. Smith, who it was hoped would have been present to exhibit and give the history of the photographs supposed to be taken by James Watt or Matthew Bolton in the latter half of the 18th century, was unable to enter into the subject at present, but would do so when he had further completed the history of the matter. He had, however, prevailed upon Mr. Smith to allow him to bring one of the paper pictures for the examination of the meeting.

After some conversation on the propriety of entering into any discussion of the subject in the absence of full details.

The CHAIRMAN expressed a conviction that it was quite competent for members to discuss the matter so far as it was before them, confining themselves chiefly to the question, was the picture before then a photograph or not; was it produced by the hand of man, or the pencil of nature.

Mr. SHADBOLT said that Mr. Smith having communicated to him various points of evidence in confidence, his mouth was sealed as to details, but he had no hesitation in expressing his conviction that the picture before them was a photograph and that James Watt was the inventor of photography in this country.

The SECRETARY asked Mr. Shadbolt if he did not mean Mr Bolton.

Mr. SHADBOLT was inclined to the opinion they were by James Watt.

The CHAIRMAN referred to the partnership of Bolton and Watt, saying that although the former was an excellent man he was more properly the man of capital and Watt the man of brains. As an engineer himself he should prefer to think it was he who invented this art 70 or 80 years ago.

After some further conversation on the subject,

Mr. G. WHARTON SIMPSON said he was afraid that the sub-

ject would be difficult to discuss satisfactorily in the absence of more evidence than was before the meeting. One or two others present and himself were in possession of many details they were not at liberty at present to make public; but he thought Mr. Shadbolt would agree with him that they might state thus much, that some of the pictures were labelled "Sun pictures by J. W." which seemed to settle that part of the question in favour of Watt.

Mr. SHADBOLT said there was even more evidence than that.

The SECRETARY referred to a process of copying mezzotint engravings by Mr. Bolton, which produced such accurate imitations they could scarcely be distinguished from the originals.

Mr. MALONE had examined the specimen before them, and could not help expressing great surprise that any one should take it for a photograph. It had more of the character of a drawing in liquorice, and had no resemblance whatever, that he could see, to a photograph.

After some further remarks,

Mr. SIMPSON said if the matter were discussed it should be distinctly borne in mind that it was not asserted that these were photographs by any process now known. It was simply stated that they were sun pictures, obtained in some way by the agency of light. Any deduction drawn from a comparison of these with ordinary photographs would be very likely to lead to error.

The CHAIRMAN said this was undoubtedly true, but still it might be possible to arrive at some conclusion from an examination of this picture as to whether it was produced by chemical action or hand labour.

Mr. MALONE said they could only examine it by the evidence before them, and on that evidence he affirmed that there was no reason to believe it to be a photograph.

The SECRETARY said perhaps he was to blame to bring this picture before them without being permitted to bring other evidence. There were, however, two Daguerreotypes, in all respects resembling the early pictures of Daguerre, but these were taken as early as 1791, one being a picture of Mr. Bolton's house before the alteration in 1791, and the other, which at first appeared to have nothing on it, was found, on careful examination, to be a picture of the house after the alteration. It was not until, in company with Mr. Thurston Thompson, he examined this in a strong light that he discovered anything on the plate at all.

Dr. WRIGHT called attention to the paper being common writing paper with a water mark, such as no one would have used for producing a finished drawing upon; if the picture before them were not a photograph it was an exquisitely finished drawing.

Mr. DEBENHAM said there were some minor stains and imperfections in the print before them which looked marvelously like those which would arise in photographic manipulation.

After some further conversation, Mr. ALLEN said that the print showed decided signs of being produced by the hand of man, all the touches of the brush were quite apparent.

Mr. SIMPSON said he was afraid that some members were looking at the picture as a photograph from nature, whereas it was a reproduction, a copy of a picture, and as such should of course accurately reproduce the touches of the brush.

Mr. HENRY WHITE expressed a decided conviction that it was a photograph. On examining it carefully it would be seen that the original from which this had been copied had a rough surface, and the small protuberances or excreescences each cast a shadow which was here accurately reproduced, showing that it had been taken by light. It would have been scarcely possible to produce such an effect by hand if it had been tried.

Mr. BROOKES had noticed the same fact and drawn the same conclusions.

Mr. SHADBOLT said that although they could not discuss the matter in its entirety, it might be interesting to restate the particulars which had already been published. (He here detailed the particulars which appeared on p. 193 of the PHOTOGRAPHIC NEWS, vol. 7, April 24th.) The evidence so far as it had gone was quite sufficient, he thought, to prove in a court of law that these were photographs taken by James Watt; but Mr. Smith thought he could make it better, or even indisputable. He (Mr. S.), as a photographer ever since the introduction of the collodion process, felt convinced that these were photographs in the most complete sense of the term, produced by the action of light.

Mr. MALONE reiterated his conviction that there was nothing to prove that these were photographs at all. The prominences referred to might be roughnesses in the paper where the colour had not taken well.

The CHAIRMAN referred to the fact that the pictures were not upon the paper itself, but upon some varnish or medium. Possibly some artist could help them by saying if any method of working on such a surface so perfectly were known.

Mr. DEBENHAM said if the prominences were, as Mr. Malone said, roughness in the paper, that might be ascertained by looking through. (This being done it was found that the prominences were not in the paper.)

Mr. BROOKES suggested that they might have been drawn by the aid of the camera lucida, and then both the correctness of the drawing and its reversed character would be accounted for.

After some further desultory conversation on the subject, it dropped.

The SECRETARY showed some instantaneous stereographs, by Mr. Davenport, of London Bridge, on the entrance of the Princess Alexandra.

Mr. BROOKES then read a paper on the action of the blue ray on the iodide, bromide, and chloride of silver, in producing the photographic image. The argument advanced was an ingenious one, but appeared to us to be based on a misconception of the exact meaning of some terms in chemical nomenclature.* He argued that as phosphorescence was the result of the blue ray it contained phosphorus, and that photogenic action was the result of minute particles of phosphorus in the blue ray diffused through the universal ether. To illustrate this he dissolved phosphorus in ether, and exposed an excited collodion plate to the vapour, he then developed it, and obtained a reduction similar to that produced by light.

Mr. DEBENHAM asked Mr. Brookes if he imagined the ether of the chemist was the same substance as that diffused through space.

Mr. BROOKES said "No," he had used the phrase rather as an illustration than as a statement of a fact.

Mr. DEBENHAM thought that all which had been proved by the experiments detailed was that phosphorus would fog an excited plate.

Mr. BROOKES said that he was merely quoting Dr. Phipson in ascribing phosphorescence to the action of the blue ray. If paper were treated with tartaric acid and then submitted to the rays of the sun, it would absorb light, which would afterwards have chemical action.

Mr. DEBENHAM said that M. Niepce de St. Victor's idea of bottled light was exploded.

The CHAIRMAN moved a vote of thanks to Mr. Brookes for his paper, and invited further comment.

Mr. MALONE remarked that Mr. Brookes laboured under a fundamental error of judgment in supposing that phosphorus existed in light, and in imagining that his experiment proved such a thing. Because he had produced a body resembling the photographic image by the use of phosphorus, he argued that light contained phosphorus. However plausible such an argument might appear at first glance, it was altogether fallacious. The salts of silver could be reduced by many agencies. The oxide could be reduced by heat; the chloride by heat and hydrogen, and also by light. But because phosphorus and other agents would reduce silver, was it to be argued that these agents were all present in light? He had used phosphorus for reducing silver, at a former meeting, but for illustrating a very different point. Mr. Malone then referred to Mr. Glaisher's experiment, and remarked that the result was most probably due to the dryness, as chemists had an axiom that without solution there is no chemical action. He then proceeded to describe some further experiments he had made, in verification of the theory he held that the photographic image was simply metallic silver in an amorphous condition. When chloride of silver without organic matter was reduced by light, it resembled the photographic image, but when treated with hypo it lost something of that appearance, and therefore some persons denied that it was the same substance as that in the fixed photographic image. He had contrived to mix it with gelatine and then reduce it by light, and he thus produced amorphous silver, and this, when treated with hypo, retained its amorphous form. He then mixed it with alcohol and ether, diluted with water, to get it into a thin solution, such as he now held in his hand. It now only remained to analyze it by first weighing

* See a letter from Mr. Brookes on another page.

the amorphous silver, then melting and weighing again, and if it had lost nothing, which he felt assured would be the case, that would make the evidence quite perfect. He concluded by repeating that Mr. Brookes's experiments simply proved nothing beyond the fact that the results produced by light could be produced by other means.

Mr. BROOKES repeated his remark that, according to Dr. Hipson, phosphorescence was induced by the blue ray.

Mr. MALONE said Mr. Brookes was confounding a substance with a phenomenon. Phosphorescence was not phosphorus.

Mr. BROOKES again referred to the bottling up of light, which—

Mr. MALONE reminded him that this had been disproved.

After some further discussion,

Mr. BROOKES expressed an idea that, although phosphorescence and phosphorus were not the same—phosphorescence might become phosphorus.

The CHAIRMAN said Mr. Brookes was evidently confounding two distinct things, and after a few more remarks the subject dropped.

Some further conversation on the alleged photographs of James Watt followed, after which,

The CHAIRMAN said the Chief Baron regretted his inability to be present, but had expressed a wish to meet the Photographic Club and the members of the Society at an annual dinner shortly, when he hoped they would be honoured with the presence of ladies. Before leaving, he recommended members to examine the apparatus kindly brought by Mr. Dallmeyer for their inspection. It appeared to be designed on philosophical principles, and constructed with great care and excellence. The proceedings then terminated.

Photographic Notes and Queries.

BURNING CLIPPINGS OF PRINTS, &c.

SIR,—I have read Mr. England's paper on the recovery of "Photographic Wastes," reported in your valuable NEWS. If you allow me I will tell your readers of an improvement in burning the cuttings and other silvered papers. I take a large flower pot, fill it with the material to be reduced into ashes, and cover it with a large dish, then reverse the whole, so that the dish be underneath, raise a little the pot from it, and in three or four points of its circumference place small stones to admit a draught of air. Set fire to it all round, and the whole will burn thoroughly, the smoke escaping from the hole of the pot, thus not wasting a single particle of the material, either in flames or by wind, the whole having been placed under a chimney to dispose of the unpleasant smell and smoke arising from the combustion.—Yours very obliged,

P. T.

Miscellaneous.

SIR DAVID BREWSTER AND THE STEREOSCOPE.—The *Daily Telegraph*, in recently describing a picture by Mr. Baker, referring to the different figures and their occupation says:—"Sir David Brewster is taking credit to himself for the invention of the stereoscope as a means of demonstrating the theory of binocular vision; while Professors Owen and Faraday are listening, in the absence of Professor Wheatstone, to Sir David's lecture on optics." In answer to this, Sir David writes to the journal in question, stigmatizing the paragraph as a "groundless and malevolent insinuation," and that he had, in 1861, written to the *Times* and to Mr. Baker, saying:—"I think it right to state to you that I am not the discoverer of the stereoscope I am only the inventor of the lenticular stereoscope now in universal use," and adds, "In my 'Treatise on the Stereoscope,' published in 1857, and in various articles on binocular vision of an earlier and a later date, I have endeavoured to discover who were the different inventors of the stereoscope—for every important invention has many claimants—and I have always given Professor Wheatstone the credit of being the first and the only inventor of the reflecting stereoscope.

METRIC WEIGHTS AND MEASURES.—Mr. W. Ewart, chairman of the Select Committee of last year upon the subject, has proposed a Bill for decimalizing our weights and measures, and

making them correspond with those of other countries; and the Bill has on it also the names of three other members of the committee—Mr. Cobden, Mr. Adderley, and Mr. Finlay. The Bill would not come into operation until after three years from its passing. The system proposed would rest upon the metre, which was originally based on the ten-millionth part of the distance from the equator to the pole. The Bill proposes to enact that the unit of the measure of length shall be the new yard, or metre, of thirty-nine inches and 37,079 hundred-thousandths of an inch; that the unit of the measure of surfaces shall be the square of the new yard, except that the square of 100 new yards shall be the unit of land measure, and shall be denominated the new acre, or "hectare;" that the unit of the measure of capacity shall be the new quart, or "litre," the cube of a tenth of the new yard; and that the unit of weight shall be the weight of a new quart of distilled water, to be denominated the "kilogram," the half of which shall be the new pound, consisting of 1 lb. 1 oz., 3 drachms, and 326 thousandths of a drachm avoirdupois. The thousandth part of the kilogram to be called the "gram," and be used in pharmacy and for weighing bullion and precious stones. Tables would be issued by the Board of Trade showing the proportions of these to the old weights and measures. There would be penalties for using the old weights and measures. The Bill is not appointed for second reading until the 1st of July.

PHOTOGRAPHIC PIRACIES AND ITS CONSEQUENCES.—At a recent sitting of the Bankruptcy Court, Mr. Ball applied for his release from custody under the following circumstances. An action had been brought against him by Ernest Gambart, for pirating engravings of the well-known pieces called the "Horse Fair" and the "Light of the World." There was a verdict against him, with £10 damages, but the Court granted a *recurso nisi* for a new trial. The question was argued, and it was finally held that a photographic piracy was within the Copyright Act, whereupon Ball was obliged to come into this court. In his examination he said that a person had told him that Gambart had declared he would "smash him up." The Commissioner said the bankrupt had some reason to suppose he had a good defence to the action, the question as to photographic likenesses being an infringement on the Copyright Act, having never before been decided. There being nothing else against him, he would order his immediate release from custody. In the *Daily Telegraph* of a subsequent day, Mr. Gambart denies the bankrupt's allegation, as to having expressed an intention to "smash him up," saying, "I beg to state that I not only never used such words, but that I know nothing of Ball, except that he has put me to some considerable law expenses. Prosecutions for the infringements of my copyrights are carried on by my solicitors from general instructions to defend my property, without special reference to me, nor animus on my part against the offenders. In the present case I expressed my desire to allow Ball to pass the Bankruptcy Court unopposed, but my solicitor thought it his duty to act otherwise, Ball having declared that he would use his freedom to infringe my copyrights again. . . . I have been put to more than £100 expense, and over half a year's trouble, to get redress against Mr. Ball—and what is the result?"

EFFECTS OF LIGHT ON ANIMAL LIFE.—Light has an undoubted influence on the growth of some of the lower animals. Animalculæ grow, in water, much more readily in the light than in the dark. If equal numbers of silkworms be exposed in a light room and a dark one, many more larvæ will be hatched from the former than the latter. Dr. Edwards found that the development of tadpoles into frogs may be prevented by the absence of light. They only grow into big tadpoles. Several facts tend to the belief that the human body is greatly amenable to the influence of light. Persons living in caves or cellars, or in dark streets, are apt to produce deformed children; and the workers in mines are liable to disease and deformity beyond what could be accounted for by the condition of the atmosphere. It has been affirmed by Sir A. Wylie that, in a large barrack at St. Petersburg, Russia, the cases of disease in those men who have lived on the dark side for many years are three to one compared with those on the light side.

Talk in the Studio.

FLAT BATHS.—We have recently had from Messrs. Bland and Co., some flat baths of excellent form, which for many

purposes are exceedingly convenient and useful. There is a well or reservoir at one end, into which the solution is tilted, whilst the plate is laid flat at the other end. By slightly raising the bath the solution flows in an even wave over the plate, and allows the use of a very small quantity—a point of consideration in using large plates, or in experimental operations. The especial advantage of these we are noticing, consists in the fact that they are sufficiently deep to avoid the risk of spilling the solution in the necessary fillings.

SHEPHERD'S CARD LENSES.—At the conclusion of an article in our last, on Glass-houses, by Mr. Blanchard, he asks our opinion of some prints produced in the studio in question with one of Shepherd's card lenses, as improved by Mr. Squire. The lighting was very satisfactory, and the work of the lens excellent. We have since had an opportunity of trying one of these lenses, received from Mr. Squire. The diameter is $1\frac{3}{4}$ ths of an inch, the back focus is a little under five inches, and the equivalent focus about six inches. For card portraits its action is very satisfactory, defining well with a moderately large aperture, and working quickly. In the Waterhouse diaphragms, an ingenious method is adopted, which allows the outer tube or jacket to travel over the stop, instead of having a large slot in the tube as is usual. This prevents light entering when no stop is used; but it has the disadvantage of not permitting a change of stops without altering the focus.

ENAMELLED PAPERS.—We have received from the Hon. Nassau Jocelyn some further beautiful specimens of enamelled paper, and also of another photographic paper, of which we shall have more to say. We learn that this paper is prepared by M. Beyrich, of Berlin, and that Mr. C. Trubner, of St. Dunstan's Hill, is the London agent. We have also received further samples of Schering's paper from Mr. Spencer, which show decidedly an improvement in preparation. The finest prints we have yet seen on enamelled paper are some sent to us by Messrs. Harvey, Reynolds, and Fowler, on paper for which they are agents, but prepared by whom, is not stated. The prints are exquisitely delicate and brilliant. We have also received from Mr. Cooper some samples of enamelled paper without albumen. We have only made a hasty trial, but are much surprised at the results. The tone is black in the printing frame, and remains so when fixed in hypo without having been toned in any way whatever. We shall be able to give further particulars of Mr. Cooper's experience and our own shortly.

To Correspondents.

MR. CLARK ON "PHOTOGRAPHY AS A FINE ART," &c.—We have received three or four communications on Mr. Clark's recent papers before the Scottish Society. His rapid platitudes on the art-claims of photography are more than answered in the communications of R. A. S. and Mr. Fry, which appear on another page. On the splenetic part of his communications, another correspondent, H. L. Snowden, writes: "Who is this Sir Oracle who lays down the canons of criticism and good taste with such self-satisfied egotism? He appears to have digested the venom of his spleen till it hath split him! Some of the critics seem some long time ago to have pinched him, and he has had no opportunity of squeaking until now; but what has Mr. Shadbolt done lately to be so indecently bespattered with bad language?" We know nothing of Mr. Clark except that he has produced some good photographs and two foolish papers. The cause of the last attack to which you refer appears to be this: At a conversation at Glasgow, Mr. Mactear read a paper which some time ago appeared in the *Photographic News*, having been contributed by Mr. Mudd. This we are sure was done without the slightest intention of plagiarism, or we might have felt aggrieved, and have noticed the matter. In the report of the meeting, as given in a contemporary, it unfortunately appeared as if Mr. Mactear had read this as an original composition, and Mr. Mudd very naturally reclaimed his own paper. His letter, making this reclamation, received from the Editor of our contemporary the unfortunate heading which has aroused Mr. Clark's ire. We are not called upon to discuss the good taste of the heading; but it is evident to the commonest capacity that nothing offensive was intended by it; whilst anything more offensive to good taste than Mr. Clark's unqualified charges of "gross impudence," &c., in a matter which did not concern him, and in which he had no right to intermeddle, we have not often met with. If it be intended as a defence of his friend, Mr. Mudd may well exclaim, "Save me from my friends!" As for the photographic press, it can well afford to smile at Mr. Clark's estimate of it. Mr. Clark, we believe, resides in Manchester, or near it, but we fear he has not paid the "extra threepence to learn manners."

B. B.—Your cards indicate the presence of too much top and front light. We do not quite understand the sketch of your room, but it will be almost impossible to get universally good effects without blinds. As a general rule a strong light favours density of the negative; but yours are not lacking in this respect. Your prints are mealy. Either use the acetate bath, or let your solution be made a little longer before using it.

HYP.—There is a considerable improvement in your cards, especially in

the lighting. Some are very good indeed. A little bromide added to your collodion would enable you to work cleaner, and to get rid of the tendency to little spots present in some cases. There is a slight degree of under-exposure in some of the pictures.

A POOR AMATEUR.—In testing a lens in the open air upon a restless child with flowers, agitated by the wind just in front, you certainly did not give the lens any chance. The moving flowers and restless child were not sharp, but a thorn-bush behind the child was sharp, because it did not move. Try the lens again on some still life object. Make a pile of books, or several piles, arranged so as to secure several planes of distance, and focus for one midway between the most advanced and most retired. If you then find a discrepancy between the chemical and visual foci, examine the camera carefully, and measure to see that the distance between the lens and ground glass is exactly the same as between the lens and the sensitive plate. As to the price, it appears you got it cheap.

W. S.—We should think that with a room of 21 feet long you could work the No. 2 B of the maker you name. The same lens is made with a focus a trifle shorter, we believe, for shorter rooms. It is preferable to the No. 1 B of the same maker, as being more rapid, covering better, and for the same sized picture giving more modelling and depth of focus. But we have seen very excellent results with the latter.

SRILL.—We fear you would find it somewhat difficult to construct the apparatus merely from a description; but we will endeavour to find space for further particulars shortly.

YOUNG AMATEUR.—About 23 inches is the proper distance from centre to centre of the stereo slide. If your negatives are $\frac{3}{4}$ apart, the lenses in the copying camera must be a little closer together. You will find it very desirable to have a lateral adjustment to enable you to alter the position, a little, of the lenses. Transparencies taken with a bi-lens copying camera from negatives taken with a bi-lens camera do not need cutting or reversing, as the process of camera copying turns each picture round on its axis, and produces the proper result in that way.

PHOTOGRAPHER.—The propriety of adding water to the acids in making gun-cotton entirely depends upon the strength of the acids, the temperature, and the result desired. We prefer equal proportions of nitric acid at 1-420 and commercial oil of vitriol, used at a temperature of 150° Fah. See our *ALMANAC* and various articles in our pages.

CHARLES ROWLAND.—The chief faults in your pictures arise from under-exposure, and you have too much top light. You will also get more softness and cleanliness by using a collodion with more bromide. If you send us a directed envelope we can give you the address of a capable teacher.

A.—Nitric is not the best flux for the ashes of silvered paper. Read Mr. England's paper in our number for May 15th. You probably did not use sufficient heat, and your crucible must have cracked or have been imperfect. You probably used an unsuitable collodion for your Fothergill plate, but your details are scarcely explicit enough to enable us to form an opinion.

X. X. X.—So far as we can judge, a very respectable glass-house may be made on the plan forwarded. Judging from the plan, we should decidedly place the siter at A, if placed at B there will be too much front light.

J. L.—With a single lens of 12 inches focus the largest stop we should recommend you ever to use is that of one-inch aperture. If the five-eighths of an inch stop is the smallest you have, use it wherever the light will permit you. The exposure required depends upon so many things, such as the state of the chemicals, the kind of object, and the distance it is from the camera, the condition of light, &c., that it is impossible to state it with any accuracy. In a good light, with the stop of one inch, try about ten or fifteen seconds, and with the five-eighths stop three or four times that exposure. 2. Mr. Window has used simply washed plates, with and without a final immersion in gallic acid, in both cases with good results; but with the best when using the gallic acid. The lens he used in testing the plate: was one of Dallmeyer's new stereo lenses of four and four-tenths equivalent focus. The aperture we are not certain about.

E. AND J. LANCASTER send us a photograph with a very singular defect. It is granular and mealy-looking to an extent which destroys modelling and sharpness, having much the effect of a coarse lithograph. The defect, they state, is owing to the character of the negative, which presents the same granular appearance. We should suspect the cause to be under-exposure, and pushing in development with a plentiful supply of silver, possibly taken from the nitrate bath, which, being thrown down rapidly in coarse particles, thus destroys sharpness, and gives the coarse blurred effect. Several Correspondents in our next.

Photographs Registered during the Past Week.

- MESSRS. H. PETSCHLER AND Co.**, 84, Market Street, Manchester,
Photograph of Wesleyan Chapel at Southampton.
- MR. A. S. WATSON**, 2, Regent Road, Great Yarmouth,
Photograph of Mr. Gratten Plaukett,
Photograph of Dr. Vares.
- MR. THOMAS TURNER**, Chemist, Longton, Staffordshire,
Photograph—Stereoscopic Slide of New Town Hall, Longton.
- MR. JAMES RUSSELL**, 65, East Street, Chichester,
Four Carte de Visite Photographs of His Highness the Prince
Edward of Saxe Weimar.
- MR. PETER BRIGGS**, 13, Market Place, Macclesfield,
Photograph of Rev. William Cruttenden Cruttenden.
- MR. WILLIAM DOWLER**, St. Mary Church, near Torquay,
Photograph of Rev. R. H. Barnes,
Photograph of Rev. J. M. Cox.
- MESSRS. HILLS AND SAUNDERS**, 15, Corn Market Street, Oxford,
Eight Photographs of the Bishop of Oxford.
- CAPTAIN FREDERICK JOHN DAVIES**, 29, Clarence Square, Cheltenham,
Two Photographs of Pittville Spa, Cheltenham.

* * * The Publisher respectfully requests that all remittances above 3s. may be made by Post-Office Orders, payable to THOMAS PIPER, at the Chief Office, St. Martin's-le-Grand. Sums below 3s. may be remitted in postago stamps.

THE PHOTOGRAPHIC NEWS.



VOL. VII. No. 248.—June 12, 1863.

CONTENTS.

	PAGE		PAGE
Formic Acid as an Accelerator	277	The Glass-House	283
Bromide in Potassium Iodized Collodion.....	278	Instantaneous Pictures.....	284
Scientific Gossip.....	278	Correspondence—Double Printing, &c	285
Formic Acid in the Developer. By H. Cooper, Jun.	279	Proceedings of Societies	286
Developing and Intensifying. By T. C. Leake, Jun.	280	To Correspondents.....	288
Art in Photography. By M. Blanquart Evrard	281	Photographs Registered during the past Week	288
The Influence of Photography	282		

FORMIC ACID AS AN ACCELERATOR.

A SINGULAR discrepancy of opinion and experience seems to prevail regarding the use of formic acid in the developer. The first record we have of its use appeared some ten years ago in the Society's journal, when it was proposed by the Rev. J. Lawson Sisson, for addition to the protonitrate developer, to secure good tones in collodion positives. We tried it about that time, for that purpose, without perceiving any advantage. Since then its use has occasionally been suggested from time to time. About a couple of years ago considerable discussion was caused by a somewhat indefinite allusion to its use as an aid to instantaneous photography. by MM. Ferrier and Soulier, some charming stereoscopic street scenes of Paris having been, it was stated, produced by its aid. The matter was, however, very ambiguously stated, and the photographic public were not much enlightened at the time. Shortly afterwards a communication appeared in our columns from Col. Stuart Wortley, who gave a definite formula for the use of formic acid with iron, and spoke in high terms of its value. His large instantaneous pictures produced by its aid were strongly corroborative of the statement. It was urged, however, by some that the brilliant light of Italy might have produced the results without the formic acid affecting the matter. In the course of last summer a group of two figures, portraits of the Secretaries to the English and French Photographic Societies, on a 12 by 10 plate, was exhibited in the International Exhibition. The negative of this picture, which was delicate, soft, and perfectly exposed, was produced in the studio of M. Claudet with a lens of long focus and small aperture in a very dull light, with an exposure of nine seconds. Mr. H. Claudet communicated to us the process by which this unusual rapidity was obtained, claiming for formic acid the accelerating properties. Since the publication of this communication in our own and some other journals, a more extended discussion of the subject has arisen. Many experimentalists have tried formic acid in the developer, and with, as we have said, singularly discrepant results. Amongst those who have derived no advantage from its use is Dr. Van Monckhoven, a good authority, both as chemist and photographer. Several other photographers, upon whose opinion we could place reliance, have found similar results, and made similar reports. Our own engagements have precluded hitherto a careful and systematic examination of the subject.

A few days ago we went, at the courteous invitation of M. H. Claudet, to his studio in Regent Street, for the purpose of witnessing his operations and verifying the results of formic acid in his hands. We must confess at the outset we were altogether unprepared for the amazing rapidity we witnessed. We will simply and briefly state the details of what we saw. M. Claudet's admirably appointed studio is, like many studios in London, somewhat unfortunately placed as regards light, the best light being cut off by a dark brick building which rises high above the studio, so that it

is to a large extent, as M. Claudet phrased it, in a well. Added to this, the sun shines directly into the room at mid-day, rendering it imperative to use a large surface of blinds. The lenses used for card portraits are of long focus by Voigtlander; the equivalent focus was $9\frac{1}{2}$ inches, the diameter of the lenses $2\frac{3}{4}$ inches. We stood for a negative about mid-day, surrounded by blinds to shut out the direct sunlight. So far as we can judge without direct comparison, an exposure of ten seconds would have been requisite with good bromo-iodized collodion and an iron developer. To our unbounded surprise the lens was closed with exposure of barely two seconds. We then went into the dark room to watch the development. The image flashed out rapidly and in less than a minute was completely developed, the result being clean and brilliant without the slightest trace of fog. Another plate was now prepared, and the sun having retired behind some grey clouds, a portion of the blinds were withdrawn. The exposure this time was one second, and the results in the dark room similar. Perhaps the negative might have borne the fraction of a second longer exposure, but certainly not another second. We unhesitatingly affirm that we have not seen at any time such rapid working in a studio in so dull a light.

The materials were, for the most part, such as M. H. Claudet described on a former occasion, but we may describe them again here. The nitrate bath contains—

Nitrate of silver (commercial) ...	700 grains
Strong nitric acid	3 drops
Distilled water	1 pint

prepared in the usual manner.

This works better when first used, a slight deterioration in sensitiveness being observed after it has been used a short time. When this becomes too definitely marked the bath is laid aside and thrown down.

The collodion used is simply iodized, and contains equal portions of cadmium and potassium. A stock of Thomas's ready iodized cadmium collodion is kept on hand. The ordinary negative collodion of the same maker, with the potassium of salt, is iodized about ten days before it is required for use. Equal portions of these two collodions are then mixed for use.

The developer we saw used was prepared as follows:—

Pyrogallic acid	20 grains
Formic acid (Morson's)	1 ounce
Water	$7\frac{1}{2}$ "

Alcohol, *quantum suff.*

The points upon which M. Claudet laid especial stress were care and exactitude in the formula generally. Regarding the formic acid the exact degree of purity and strength are not yet satisfactorily determined, and the proportion to be used has to be decided at present somewhat empirically by actual experiment with each fresh stock. The proportions given answer with the sample in hand. Of another sample, prepared by Mr. Hockin, of alleged absolute purity, one-fourth of the proportion given in the formula was sufficient.

It is stated to be important, however, that the right proportion of any sample should be ascertained, as with an insufficient quantity the benefits are not attained, and with excess the result is tardiness in developing and fog. It is important to use as little light as can conveniently be worked with in the dark room, or fog may ensue. And it is important to drain the plate very carefully as excess of free nitrate is apt to cause surface reduction. It will, moreover, be very evident that in proportion to the rapidity of a process, is its delicacy and sensitiveness to all causes of abnormal reduction. Clean plates, filtered solutions, and great care in all the manipulating, as well as accurate timing, is of the utmost importance.

Such are the results of our observation in M. Claudet's studio. We have made a few experiments ourselves, but they are insufficient for comparative purposes. We may, however, briefly refer to them. With a developer made after Mr. Claudet's formula, but with half the proportion of formic acid, a sample supplied by Messrs. Hopkin and Williams, we obtained with iodized collodion similar results to those yielded by iron and the same collodion with a bromide. With the same developer and a bromo-iodized collodion, the results were similar to those obtained with iron and with the same exposure. The chief action of a bromide with the pyrogallic acid and formic acid appears to be to give greater delicacy of image, but the exposure was about the same. As, however, it appears probable that much of the advantage of the formic acid depends upon a strict exactitude of conditions which we have not yet applied, we refrain from further reference to our own experiments.

We may here call attention to the detail of some interesting experiments in the same direction by Mr. Cooper, which will be found on another page, from which it will be deduced that more is still to be learnt as to the exact operation of this acid in the developer.

BROMIDE IN POTASSIUM IODIZED COLLODION.

Iodide of potassium, at one time a favourite iodizer for collodion, has of late years, since the more extended employment of bromides, fallen considerably into disuse. Whilst less stable in sensitiveness, the collodion containing this salt unquestionably favoured density and brilliancy in the image. For this quality many photographers would gladly have continued its use, if it could have been conveniently done in conjunction with a bromide: its rejection having been rather the result of necessity than choice. The bromide most commonly used has been the bromide of cadmium, which has been selected chiefly on account of its ready solubility in alcohol. But when this bromide is used in conjunction with the iodide of potassium, a double decomposition often ensues, forming bromide of potassium and iodide of cadmium. As the bromide of potassium is very sparingly soluble in the mixture of ether and alcohol employed in collodion, it is thrown down and its advantage is lost. Hence the use of iodide of potassium has fallen into disfavour.

We have recently found a method of using this salt in combination with any amount of bromide we may desire to add to the collodion. It consists in the employment of bromide of lithium in conjunction with the potassium salt. This bromide is much more stable than that of cadmium, and is also very soluble, may be used freely in conjunction with the iodide of potassium without any decomposition. The result is a collodion yielding very vigorous, clean, and brilliant negatives. To add to these qualities that of stability, it will probably be desirable to use a portion of iodide of cadmium. A collodion giving great brilliancy and delicacy, and with every probability of stability, will stand thus:—

Ether, 720 sp. gr.	1 ounce
Alcohol, 715 sp. gr.	1 "
Iodide of cadmium	5 grains
" potassium	4 "
Bromide of lithium	3 "
Gun cotton, <i>quantum suff.</i>			

Scientific Gossip.

MEASUREMENT OF THE CHEMICAL ACTION OF LIGHT—NEW SPECTROSCOPE—EXAMINATION OF GLASS.

THE measurement of the chemical action of sunlight has been a problem which has engaged the attention of men of science for many years. Under the names of Actinometer, Dynactinometer, Photographometer, &c., various instruments have been devised for measuring and recording the variations of the actinic or chemical force of the solar ray; but in spite of all the attempts which have been made in this direction, a good instrument of this kind, of easy use in observation, is still a desideratum. The subject formed the Friday evening discourse at the Royal Institution, on the 22nd ult., the lecturer being Prof. Roscoe, a physicist who has long studied the subject from a scientific as well as practical point of view, in conjunction with Professor Bunsen, of Heidelberg. The lecturer began by stating that animal life might be considered as a process of oxidation—the tissues of the body undergoing combustion in the oxygen of the atmosphere, and forming carbonic acid. Without some counteracting agency, an animal, so long as it breathed, might be said to be slowly working its own destruction by forming a gas incapable of supporting life. The counteracting agency nature supplied in the life of plants, which might be described as the opposite process of reduction, carbonic acid being decomposed and oxygen evolved. Animal force, then, was derived from the vegetable organism, and animals did not create but only manifested force, which was regulated by the same law as that of the steam engine, the force representing exactly the amount of fuel consumed. For vegetable life a continual stimulus was necessary, and this was supplied by the sun, the chemical radiations of which brought about the decomposition of carbonic acid by plants in the same way as they decomposed chloride of silver on photographic paper, and caused the combination of hydrogen and chlorine. That all the rays of light were not of equal chemical activity the lecturer showed by exposing a thin glass bulb filled with a mixture of hydrogen and chlorine, first to red light and then to violet light. In the former case no alteration was effected, whilst in the latter case an explosion took place which shattered the globe to pieces. The experiments, which were most effective, were made by burning phosphorus in oxygen gas contained in a globe of red or violet coloured glass.

The measurement of the chemical activity of solar light, the lecturer continued, was a subject of great importance and interest, inasmuch as it afforded a means of estimating the vegetable and consequently the animal producing power of a country or district. He had therefore made experiments with a view to obtain an easy and exact method of measuring the chemical action exerted by the total sunlight at any point of the earth's surface, under the different conditions of situation, climate, and state of atmosphere. It was known that the real climate of two countries might differ very widely, and yet the mean temperature of the two be nearly the same. This was shown by the vegetation of the two. To illustrate this, the lecturer exhibited photographic views taken near Carlisle, and in one of the Shetland islands—the mean temperature of these two localities being nearly the same. The vegetation about Carlisle, however, was luxuriant, while not a tree was to be seen in the Shetland views. These differences were owing to the different intensity of the chemical action of light, and not to temperature. The foggy, cloudy atmosphere of the Shetlands absorbed the chemical rays which would stimulate vegetation. It was of consequence, therefore, to have a means of determining the chemical activity of light, the measurement of which would create a new and important branch of meteorological science. In conjunction with Professor Bunsen, the lecturer had some years ago constructed a chemical photometer, for estimating the chemical activity of light, by its

effect on a mixture of hydrogen and chlorine. This instrument, however, was too complicated to be available for meteorological purposes. Another and simpler way of measuring the activity of diffused or direct light on any given spot was necessary, and the mode proposed was the registration of the result produced on photographic paper. But before such a mode could be made available, it was necessary to know how to obtain photographic paper of constant sensitiveness, and also what relation there existed between the degree of tint produced and the time and intensity of light necessary to produce it. After a series of experiments, the lecturer had succeeded in preparing a paper of constant sensitiveness, and in the method which he proposed to have adopted, the comparisons were not made between the different tints of the papers, but between the different amounts of light which were radiated by the variously-darkened surfaces. The method was founded on direct observation. It was possible to measure the time required to produce a given tint on standard paper, and the intensity which produces this tint in the unit of time is called the unit of chemical intensity. If two units of time are necessary, the intensity will be one-half, and so on. The time of insolation is measured by means of a pendulum photometer, in which the strip of prepared paper is exposed for a varying but exactly known time. By the action of the pendulum, a piece of blackened mica is passed and re-passed over the paper. Different parts of the paper are necessarily exposed, for different lengths of time, but the time of exposure of any part can be calculated exactly from a scale. The strips of paper thus insolated exhibit a regularly diminishing shade from black to white, and the point at which the paper has a shade equal to a normal tint, fixed by means of hyposulphite of soda, can be accurately read by comparing the two strips, by the aid of monochromatic soda light. In illustration of this the lecturer showed the effects of the sodium flame on the words "monochromatic light," printed in letters of various colours, and also the way in which the exposed papers were compared; but it would be impossible to make the latter intelligible, unless the apparatus were before the reader. The experiments by Professor Roscoe and another observer at Manchester have shown that two experimenters may closely agree in their estimations of tints by this means. The lecturer then briefly referred to some measurements he had made of the chemical brightness of various points of the sun's surface. From these it appeared that the chemical brightness of different parts of the sun's disc is very different, the central portion being from three to five times brighter than portions of the edge. He had found, too, that the brightness of the picture varied irregularly; a coarse, mottled appearance being produced, very different from the ordinary mottling seen on the surface of the sun. He had satisfied himself that this appearance was not due either to the paper or the lens, and he thought it probably arose from clouds in the sun's atmosphere, and might be connected with the red prominences seen in eclipses. The professor remarked in conclusion that he was convinced that interesting and valuable results might be obtained by the methodical carrying out of actino-meteorological observations, such as he had described, and he looked forward to the time when all meteorological observatories would be furnished with instruments for pursuing it.

Those of our readers who possess spectrum apparatus may be interested in knowing of a plan which has just been devised by which all the benefits of a large instrument are obtained with half the number of prisms and lenses. In the ordinary instrument the ray of light passing in at the slit goes through the collimator and train of prisms to the telescope, and thence through the eyepiece to the observer. The improvement, which is due to M. O. de Littrow, consists in allowing the ray of light to pass through the slit, collimator, and prisms as in the old arrangement. It then falls perpendicularly upon a plane mirror and is reflected back through all the prisms a second time. It then passes through

the collimator, and, if not arrested, would proceed to the slit again. But the collimating lens is identically the same as the object glass of the telescope, so it is only necessary to interpose a plane reflector in the path of the return rays between the collimator and slit, to deflect them sideways through an eyepiece where the spectrum is examined. By this arrangement one lens is dispensed with and a double effect is obtained by the same number of prisms; moreover, the proximity of the eyepiece to the slit facilitates manipulation.

A correspondent, H. G., has forwarded a piece of glass for spectroscopic examination. In the instrument it is seen to cut off all the chemically active rays down to the green; it may therefore be used with perfect safety. The colour is deep orange: it is flashed with silver.

FORMIC ACID IN THE DEVELOPER.

BY H. COOPER, JUNR.*

A FEW weeks back I sent to the photographic journals a *resumé* of some experiments with formic acid in the developer as an adjunct to great rapidity in working the wet collodion process. (I have not as yet tried it with the dry processes, but hope to do so during the ensuing summer). I have since continued my experiments and have arrived at some very curious results, a few of which I shall have the pleasure of showing you this evening. I have brought very few examples with me as I think it is better to exhibit a small number that clearly show the different results obtained, than to perplex you with a great many that only confuse, and lead to no correct opinion being formed.

My first series of experiments were devoted to the attention of iron as a developer; but when I wrote the letter to which I referred, I had not used for trial the double sulphate of iron and ammonia. With this salt, employed as usual, I am much pleased, as it is much easier to work and therefore more pleasant than the ordinary sulphate. I am also of opinion that it requires rather less exposure in the camera. From this I was naturally led to expect that the reduction in the time of exposure would be still greater if it were employed with formic acid. I was rather disappointed with the results which showed that little or no increase of rapidity is gained; but on the whole I think a more delicate negative is procured.

I ought to have mentioned in what manner my experiments were conducted; for if the plates are not exposed simultaneously, no definite conclusion can be arrived at. Much unnecessary discussion has arisen through carelessness or neglect of this precaution. I had several stereoscopic glasses cut across the centre with a diamond, so that, after exposing the plate by the means of a pair of stereoscopic lenses, it may be broken and the two halves developed in different ways. It is also requisite that the lenses be fitted with some contrivance for uncovering them at the same instant.

During the past week I have turned my attention to formic acid, used with pyrogallic acid, and it was during these experiments that some most curious anomalies presented themselves.

The first plate (which I now produce) I exposed during a very weak and muggy light. You will observe that the half developed with pyro and formic acid is clean and brilliant, though under-exposed, and that the other half, developed with the ordinary solution of 15 grains of sulphate of iron and 15 minims of acetic acid to the ounce of water, is much stained, and that only a mere trace of an image is visible. I immediately exposed another plate with the same result. I purposely gave them all less exposure than I should if I had intended to develop them in the ordinary way.

I then waited till the light had become very bright, and exposed another plate, which I bring with me, in which the

* Read at a meeting of the South London Society, June 11th.

part developed with pyro, as before, appears considerably less exposed than the one developed with iron.

From repeated experiments which have given analogous results, I have formed the following conclusions:—First, That under certain conditions formic acid is a decided accelerator in *any* developer; for instance, when the light is so weak that sulphate of iron will not allow the development to be pushed sufficiently without staining the negative; formic acid, under these circumstances, produces, as I have observed, a striking improvement. Secondly, But that in a good, strong light, the usual developer of iron requires less exposure to produce a satisfactory result than pyro and formic; and that formic acid and iron, with a little acetic acid, is quicker than all. In making these remarks I wish you to understand that all the chemicals used are in good working condition.

DEVELOPING AND INTENSIFYING.

BY J. C. LEAKE, JUN.*

PERHAPS no term is more often misapplied than this one, intensity. I am not quite sure if I know its meaning myself; but I think, as applied photographically, it means that quality which will enable the negative to reproduce on paper an impression of the original subject photographed in its correct light and state.

This being granted, we will proceed to examine the various processes used to this end.

One error seems to me prevails largely among photographers on this subject; it is this, that the same amount of brilliancy is necessary in all their productions. Now I venture to suggest that this is wrong, and, that while for many, perhaps most subjects, the more brilliant the lights and the deeper the darks, the better; yet in some cases it will be advisable to diminish the intensity in order to produce a softer and more artistic effect.

I make these remarks, because as we proceed, you will find I lay down no definite rule as to intensity, but endeavour to explain the tendency of each process named, leaving the application to individual judgment.

Some years since, when a simply iodized collodion was used, the impression being developed by pyrogallie acid, no difficulty was experienced as to getting a full amount of intensity. But the introduction of bromides, and iron development made so marked a difference in the beauty of gradation and the capacity with which pictures could be produced, that notwithstanding it was often found difficult to get sufficient density for printing purposes, the process has come into general use.

I am not of those, however, who think the image on bromo-iodized collodion developer with iron, is necessarily thin. On the contrary, I believe that, with proper care, an impression may be obtained of sufficient density to print at once without any intensification whatever, although I do not think it judicious as a rule.

If we start by examining the conditions likely to affect the intensity of the image, we shall perhaps be better able to understand the subject.

To begin with the collodion; of course, bromo-iodized. The best results will undoubtedly be obtained when it has been iodized at least a week. If the image is thin (as it would be if the collodion were used immediately after iodizing), it cannot readily be brought up to the required strength. It is well to have a good full film, or it will be difficult to obtain a rich, deep negative. But most important of all is the condition of the silver bath. I may as well at once confess to heresy on this point; for notwithstanding all that has been said and written to the contrary, my opinion still is, that the presence of an acetate is of the utmost use, both as to rapidity of action, density, and colour of the deposit. The presence of uric acid, often recommended to be added to the bath, has a tendency to produce

a grey metallic deposit, which is next to useless for printing, and very difficult to intensify. If carbonate of soda be added to the nitrate solution, and left in contact with it some hours, it will be found that the image, which before was grey and transparent, is now of a rich brown, much more intense, and capable of being intensified to almost any extent. As might have been anticipated, the length of exposure affects the intensity to a large extent, and it will be found that the best results will be obtained when the exposure has been so prolonged that one application of the developer is sufficient to thoroughly bring out the impression.

From time to time various substances have been recommended as likely to increase the density of the image when used in conjunction with the ordinary sulphate of iron developer. After trying a number of experiments, however, I am inclined to think that, as a general rule, a developing solution containing from ten to twenty grains of iron, and the same proportion of acetic acid, will be found to answer for general purposes better than one made according to more complicated formula.

At this stage of the process the image should present the following characteristics,—all the details should be well out, the high lights sharp, while in the deepest part of the shadows the iodide should remain unaltered in colour, the whole picture standing out boldly and having a generally "plucky" appearance.

I am convinced that a great deal of time and trouble is wasted, and many failures incurred (the blame being thrown on the process employed), in trying to intensify pictures which cannot by any process be made to yield a respectable print by reason of their infirmity; and the unfortunate man who has suggested a process for intensifying which answers well in his hands, is consigned to various places as a "muff," because that same process will not convert anything anybody may happen to get into a first-rate printing negative, without any trouble whatever.

So that while I cheerfully admit that "dodges" may be useful at times, the best "dodge" will be to endeavour to secure a picture which will require as small an amount of after treatment as possible. There now remains three stages during which the negative may be intensified—before the removal of the unaltered iodide by the fixing agent, after the fixing process, and also after the film is dry. Intensifying, at each of these stages produces a slightly different result. The softest negatives are, as a rule, produced by using a weak solution of pyrogallie acid and silver before fixing; but it should be remembered that unless very carefully used this process is likely to obscure the delicate detail of the negative by a heavy deposit of silver. If, however, the iodide be removed by fixing, this process with pyrogallie acid is perhaps the safest and most certain now in use, and, doubtless, in good hands is capable of producing the most beautiful results. For my own part, I am inclined to think these two methods may be used in conjunction most advantageously, a little being done before, and some after, fixing. If the original negative be very thin it will often be found difficult to obtain the requisite density for printing after fixing; but if we intensify slightly before, we shall have but little trouble afterwards in obtaining any reasonable quantity. Before the iodide is removed the intensity seems to be obtained by an actual deposit of silver, but after its removal scarcely any silver appears to be deposited, but the colour of the negative is altered from grey to a rich non-actinic brown. Greatly favouring, as I do, the idea that intensity by colour is better than intensity by deposit, I think that if a fair amount of deposit can be obtained by iron, and this slightly altered in colour by the after application of the pyrogallie solution after fixing, better and more delicate negatives may be produced by this than by any other process; but it must be borne in mind that an increased tendency to hardness accompanies all processes used for intensifying *after* fixing. It may not be out of place to mention here that, when it is intended to use this process, the hypo-

* Read at a meeting of the London Photographic Society, June 11th.

sulphite of soda will be found the best fixing agent; while for the others to be mentioned cyanide is to be preferred, as leaving the deposit in a better condition for the after applications.

The ordinary sulphate of iron developer, with the addition of citric acid, has been recommended as a convenient intensifier. That it is clean, and works evenly and steadily, cannot be denied, but I think it is objectionable on account of the colour it produces—grey. It is, in fact, density by deposit instead of by colour, and is therefore to be avoided. The application of a solution of iodine to the film before intensifying with pyrogallie acid has also been advised, and, where the original deposit is very thin, is undoubtedly useful, the more so as it slightly changes the colour.

The only important process now remaining to be discussed is that with bichloride of mercury and iodide of potassium. This comes into the third stage mentioned at starting; as to do any good the film must have been dried before the application of the solutions. As a preliminary remark, I may say that it is judicious to varnish the edges of the plates to be operated on by this process, before the solutions are applied.

The fact of having made a few hundreds of experiments tends to give me boldness when speaking of this process, and I have no hesitation in offering my opinion that in careful hands it is capable of producing better results than any other; but I cannot recommend it for general use for various reasons. In the first place, if the exposure be not right to a second, no care or "dodging" will make a fine negative; and we all know—at least, all engaged professionally—that we cannot always take a second picture, while some irascible old gentleman, who wants to catch the "next train," is waiting to sit, and working himself into a state "better imagined than described," by way of securing a pleasant expression. Then the printing from the negative requires extra care, another commodity, by the way, not always obtainable—and so on throughout.

But, if prepared to give unlimited care, time, and attention to every part of the work, by all means use this process for the production of your negatives. Perhaps the most usual cause of failure in this process is the use of too strong a solution of bichloride of mercury. If, instead of a saturated solution, as usually recommended, we use one of from half a grain to a grain to the ounce of water, far better results will be obtained, and much of the unequal action so often complained of be avoided. The iodide of potassium solution of five grains to the ounce of water will be found to answer perfectly. It is a point of vital importance to the success of this process that there should be no deposit whatever on the deepest shadows. For the other methods named, this may not be so important, although it is best at all times, but it will be found useless to attempt to intensify by this method anything but the most brilliant and perfect pictures. Too great a heat should not be applied to pictures produced by this process while varnishing them, as some varnishes very readily dissolve the thin deposit of iodide of mercury formed upon the surface of the plate, leaving it in precisely the same condition as before intensifying.

Chloride of gold has been recommended as an intensifying agent; but, beyond the objection of expense, it has that of being almost useless. Hyposulphite of soda, in conjunction with bichloride of mercury, has been spoken of as useful, as also hydrosulphate of ammonia; but, on the whole, none of these substances can be favourably spoken of, the last being specially objectionable. A somewhat dangerous, yet a useful "dodge," when a negative is slightly over-exposed, is to pour over it a weak solution of iodine, and then, after thorough washing, a weak solution of cyanide of potassium, repeating the process until some one or two portions of the deepest shadows are reduced to bare glass. For positives this answers capitally, if carefully executed; and, although I do not recommend it, a negative may frequently be saved by its adoption. Of course, after this treatment, the negative must be intensified by one of the before-mentioned

processes—that with the bichloride of mercury having, in my hauds, answered best.

In concluding what I fear has been a very tedious paper, I would observe that in aiming, as we all do, at the production of brilliant and perfect proofs, it must be kept in mind that all the parts of the process depend one on the other, and that perfection will only be attained when they are perfectly related one to the other. We are frequently astonished to hear of the most exquisite results being produced by means of a process which we thought incapable of producing them, and, on inquiry we find that the secret is simply this: the great care bestowed in arranging all the details, in order that one may work into the other.

Then the importance of the arrangement of light on the model cannot be over estimated, lying, as it does, at the root of the question of intensity; and it will be useless to work up processes for the production of perfect negatives, unless proper attention be paid to this. I had intended to commence this paper with some remarks bearing on this part of the subject, but, having a wholesome fear of Mr. Wall before me, I determined to leave that to him; as I do also the responsibility which might attach itself to me on account of having taken up your time this evening, for had it not been for his kindness in dragging me out on account of a few remarks which I made to him at the last meeting, I should not have ventured to occupy your valuable time this evening.

I regret that through pressure of business I am unable to make this paper more perfect. Many experiments intended I have been unable to perform; but I have laid before you what is done, in the hope of resuming the subject at a future time.

ART IN PHOTOGRAPHY.

BY M. BLANQUART EVRARD.

WE know how little is due to art in the production of a photographic negative. The selection of the subject, the lighting of the model, and the pose, when it is a living subject. This is but little, yet it is all to which the influence of art is reduced; and still, little as it is, it is easy to recognise it in the pictures of operators who have a true perception and feeling for art, while we often have to regret its absence in those operators who owe all their success to science and skill in manipulation.

Thus amid the magnificent progress imparted daily by science to photography, how much regret we experience that art remains as it was at its *début*—powerless to modify, by taste or feeling, the picture proceeding from the Daguerrian camera. Let us conceive what a transformation photography would undergo if the operator would but regard the picture drawn in the camera by light only as a beautiful, faithful sketch waiting artistic inspiration to be completed. It would be like those rare engravings which, beside faithfully reproducing the work of the painter, bear also the impress of the individual feeling of the engraver, and render the copy superior to the original. The problem to be solved will then be to limit the marvellous but intelligent work of the camera to the complete but not intense formation of the image, and giving the photographer the means of continuing it, and modifying at will the aspect and accessories, and substituting, so to speak, his action for that of the camera, and employing the same chemical means of execution. It is not a galvanic action like that we were the first to indicate in 1851, and which consists in precipitating by means of a metallic bath upon the image ready formed, but recognised as too weak, a fresh quantity of metal to strengthen it: This process, in daily use, can, fortunately, be performed only upon the whole surface of the negative; its result does not solve our problem as it does not modify the effects of the picture, it only changes the scale. Nor will it consist of the re-touches which a skilful hand is sometimes obliged to add to a negative. What pencil is skilful enough to combine its work with that performed by the luminous rays? and yet

the result we must obtain should be the power of strengthening this or that portion of a picture at pleasure:

The artistic work of which we speak in this place can be produced neither by pencil nor palette, it must remain purely chemical, so as not to alter the purity of the lines, and have the picture in a perfectly homogeneous condition, with all its finish and delicacy of execution. We must discover an agent so subtle as to be able to rival light, or, still better, have recourse to light itself. The problem to be solved will therefore assume the following form:—

Bring the light to continue, and to modify in its effect, at the will of the operator, the image formed in the camera.

When a layer of iodized collodion is moistened with a solution of nitrate of silver, there is an exchange of bases, and formation of iodide of silver with excess of silver: This is what in practice we term the sensitive film.

Exposing the sensitive film in the camera, all the points more or less luminous of the image act upon the sensitive film in proportion to their intensity, and a complete image is formed, but invisible after an ordinary exposure.

It might be thought that this image would be visible by transmitted light, but nothing is visible to the naked eye. It is necessary for the latent image to be revealed, to be submitted to the action of one of the three developing agents usually employed—gallic acid, pyrogallic acid, or sulphate of iron. The picture then manifests itself under the form of a metallic precipitate, weak in those parts where the action of the light has been feeble, abundant where it has been intense. It is from this variety of transparency or opacity in the parts of the image that results that beautiful gradation of light and shade which forms the charm of successful pictures.

The abundance of the precipitate produced by the action of the reducing salt upon the portions of silver impressed by the light is therefore proportional to the intensity of that impression. If the image is deficient in opacity on account of the precipitate being too weak, it shows that the luminous action has been insufficient. We must in that case submit the negative to a fresh exposure in the camera. But this result, good in theory, has no practical value, and only in very rare cases can we resume the pose of a model, under conditions precisely identical; and, moreover, if the thing were easy, we should only possess a new method of strengthening, which is not the object of our inquiry.

It would be entirely different if we could succeed in isolating the image from its medium, or, in other words, if we could preserve to the elements of which it is composed, their photogenic properties, and render insensible to a new exposure the metal, which, not having been impressed at first, remains useless to the formation of the picture.

To arrive at the solution of this interesting problem, let us first study the conditions of the formation of the picture upon the collodion negative.

Contrary to what takes place upon a paper negative, where the image is deeply impressed in the whole texture of the paper, the picture of a collodion negative is formed only by the reduction of silver precipitated in the state of a metallic powder, without cohesion, upon the collodion film, from whence it is removed upon the least contact, without leaving any trace of the image.

Evidently the reductions arise only from the salts of silver in excess in the formation of iodide of silver.

For, if by washing in abundant water we remove from the sensitized collodion the greater portion of the excess of silver which, in ordinary practice, is found on the surface of the film after exposure in the camera, the developer will, after the exposure, yield only a scarcely visible image. If we then pour upon the negative a solution of nitrate of silver, the image will take what it requires from the silver, and manifest itself strongly. Now, if instead of limiting ourselves to washing the film in abundance of water, we re-cover it with a solution of the reducing salt, which, combining with the silver in excess, is carried away with it during the washings, and we afterwards expose it

in the camera, we should have to submit it anew, after submitting it to the action of the reducing salt, and no trace of the picture will be revealed, although the principle of this image exists, since it appears, as in the preceding case, in presence of a solution of nitrate of silver.

Let us carefully consider the difference of the two results. In the first case, a washing in abundance of water, the production of a thin picture; in the second case, a washing followed by immersion in a solution of the reducing salt, and entire absence of a picture.

It is, therefore, well established,

1st. That no picture manifests itself without the presence of an excess of silver upon iodide of silver.

2nd. That if water alone is insufficient to remove all this excess of silver, it is not the same with the reducing salt, which combines with it, and removes it during the washings in water, which must always follow the immersion of the negative in the developing baths.

Now that it is demonstrated that the developer removes from the iodized film all the salts of silver in excess, and that then this iodide, although sensitive to light, manifests evident alteration only after it is put, subsequent to exposure, in presence of a fresh solution of silver—we have the solution of our problem.

For, if, on the one hand, as we have stated above, the picture manifests itself only imperfectly under the action of the developing salt when the impression by light is weak, and that in such case it suffices to strengthen this image, to prolong or renew the exposure; if, on the other hand, the image formed by the silver impressed by light and precipitated by the developer, retains its photogenic properties, while they are not stopped and destroyed by the de-iodizing of the collodion by means of hyposulphite of soda, or of cyanide of potassium, it will be sufficient for the operator to impress his negative by light, and afterwards bring out the image by a reducing salt and washing the negative many times in abundance of water. The negative in this state must be kept in the dark until the moment we are ready to modify the design obtained. If we desire to lighten certain parts to give them more brilliancy or importance, as we must in those parts increase the opacity of the negative, the operator must expose it to the light, taking care to intercept the action of the light by means of screens more or less directly interposed, from those parts of the design which must remain in their primitive state.

He can, at pleasure, interrupt, resume, or displace this action of light slowly enough to be able to follow it with the eye.

When he has obtained the desired effect, it will suffice, to stop it definitely, to immerse the negative in cyanide or hyposulphite, to remove from it its photogenic properties.—*Le Moniteur de la Photographie.*

(To be continued.)

THE INFLUENCE OF PHOTOGRAPHY.*

SOME day, when mankind has grown wiser, our descendants will smile at the folly which distinguished and decorated the so-called "reformers," who make a noise in the world—and not much more—and will transfer their admiration and their honours together to the true revolutionists, the men of science. It is from the closet and cabinet that the movements originate which shake the earth. The chemist, compelling some new element to the service of man, or explaining for him the occult operations of nature; the mechanic, reinforcing his weak muscles with arms of iron and sinews of steel; the geologist, anticipating over his map storehouses of glittering gold, destined to become the origin of empires; the aeronaut, launching his silken bark upon a sea to which the "unvoyaged Atlantic" of Columbus was a mill-pond; the anatomist, questioning the mind of the Creator himself by comparison of all his works together; the antiquarian, making the dead eloquent, and eliciting from

* Daily Telegraph.

jaw-bones that died in company with mastodon and mammoth, the story of the primeval earth—these, and not the jaunty gentlemen in stars and ribbons, are the men whom history will take note of.

Photography—almost the latest born of scientific inventions—is a proof of what we mean. At first only the experiment of the savant in his study, it has become in turn an elegant amusement, a trade and a necessity, until we almost wonder how our forefathers managed to be satisfied with silhouettes and miniatures. It would take all the columns that lie before the reader even to touch upon the thousand and one ramifications of the simple discovery which lies at the base of the art now so widely practised.

Who is to say what results may follow from the vast mass of physiognomic material which hundreds of cameras are constantly storing up? Who ventures to estimate the exact consequence of the curious familiarity which we now enjoy with the persons and peculiarities of anybody in any way "distinguished?" Who knows what comfort that simple bit of card, stamped with the sure veracity of the sunlight, has brought to the absent, the exile, the captive, the sailor, the mourner? And now we are discussing the experiments of Signor Negretti, made at the audacious height of miles in the air, and with the ear of a balloon for the "dark room." If these succeed, what change may not come over the practice of war?—if, indeed, it is to outlive all the "aids" of science. How is a general to conceal his plan of attack, or mask his advance, when the photographer has him and his army under a Voigtländer lens, and can drop a "correct likeness" of the enemy into his employer's camp every quarter of an hour. Or what unknown land will keep sources of grand rivers and gorges of mysterious mountains any longer from our knowledge, if the Spekes and Grants of the future are to sail calmly over cannibals and cataracts, focussing everybody and everything at a height where the eagle would grow dizzy? These are speculations to-day, but not half so extravagant as it would have seemed thirty years ago to promise that, with a few chemicals and a square of coated paper, exquisite and absolutely truthful pictures could be produced, shaming the minuteness of the most painstaking miniature painter—still more that the artist would take his subtle palette into the skies, and, with the sun-beams for a paint-brush, limn "Mother Earth" as the stars and planets see her.

But descending to *terra firma*, photography has lately assumed a most curious function there—that, namely, of a religious reformer. If any idea could be pronounced *bizarre* beforehand, it would have been, we should think, that the invention of M. Daguerre could have any possible connection with the decline of Mahomedanism, much less conduce to it. There is a well-known song, the wit of which lies in bringing together the most unexpected people; making Æneas play whist with the "King of the Cannibal Islands," and Charlemagne—or somebody equally astonishing—dance a polka with Mrs. Fry. Hardly less grotesque must it seem to those who know the habits of the East to read that photography is just now the rage at "the Sweet Waters," and that all Constantinople is "agog" for a portrait of the Sultan. A sharp-witted Turk named Abdullah, who has imported the art into the East, has persuaded "the faithful" to petition His Majesty *en masse* for "cartes de visite" all round; and the Sultan, no ways loath, has consented, it would seem, to be made immortal "in this style." Considering that the windows of "the infidels" are full of the portraits of their charming princesses, and that everybody, thanks to the practice, knows the blood-royal by sight as well as his own sisters, it might seem unnecessary for us to criticise the desire of Stamboul. But when it is recollected what Mahomet would have to say about such a thing, and how energetically the Koran, in its heat against idolatry, denounces "the picture of any created being," it must be decidedly a sensation to an orthodox Moslem to hear that the Viceregent of God, the Padishah of all believers, has "given a sitting." We get our word "Arabesques" from the geometrical or running adornment with which old Saracenic and Mussulman art, jealous of any imitative outline, ornamented its books and houses. Now, if the Ulemas don't quickly call the convocation of Islam together and write a number of pastoral letters in the papers, the awful heresy of Abdullah will prevail, and a good Turk will boggle no more at having his picture taken than at adultery or at cheating a Christian. Mahomet foresaw a good deal, but not the photographic camera, or there would have been a special chapter in the Koran against that "device of Eblis."

Thus silently the spirit of change is stealing over the fierce faith. It made its last wild struggle for Islam "unaltered and dominant," in the Indian mutiny. The outbreak at Jeddah, in Syria, at the Lebanon, were bursts of the same angry but fading flame; and in our day the Mahomedan Crescent is on the wane. It submits, with the patience of a tamed thing, to the hand of science; it wears the pantaloons, drinks the wine, apes the vices of civilization; and will soon come to believe that Allah has had other prophets beside the famous husband of Khadijah, "whose heart the angel Gabriel himself took out with a knife of adamant, and, washing it in the golden basin of faith and truth, replaced it sinless." Pending the inevitable revolution which is thus spreading from the centre of Islam to its boundaries—a revolution possibly tedious, and certainly slow—we must not expect too much from Turkey. It is something that she has a Sultan who, if he is a little extravagant in his fêtes at the "Sweet Waters," gives his *carte de visite* away instead of purses of gold; and presents stereoscopes, like those shown in the Exhibition, to the dark-eyed houris of his zenana. Science will certainly never run the bill up on this head to the figures quoted the other night by Mr. Baillie Cochrane. "For thirty-six wives," £70,000 per month; for 1,780 "other ladies," £18,000 a month; £7,000 per month for gentlemen of a peculiar description to attend upon this feminine family; with £24,000 beside for bon-bons, sweetmeats, kubobs, and pillaws; and £80,000 for attendants—the items were, it must be confessed, alarming. But all that was in 1659, and the friends of the empire must be allowed to be hopeful in 1863, when science has slipped into the harem, and the Commander of the Faithful submits his sublime visage to the pose desired by Abdullah the photographer.

THE GLASS-HOUSE.

THE first thing which claims the attention of the photographer, is to secure to himself suitable rooms. In many instances the artist has the privilege of superintending the construction of his glass-house or operating rooms; in this case he must not only know what is required in such a construction, but he must know what arrangements are the most appropriate. The success of many an artist depends upon the fortuitous advantages of his glass-house; but these fortuitous advantages depend upon fixed laws and principles which the photographer must learn, if he is still ignorant of them.

To be brief, contrast between light and shade is agreeable to the eye whether tutored or untutored; whereas uniformity of light or of shade is very displeasing. It is not known why this is so, any more than why harmonious combinations of notes are delightful to the ear, or why non-coincident vibrations produce discord.

By means of a *happily arranged* contrast of light and shade, a stereographic roundness is communicated to pictures, which, where this contrast is deficient or quite wanting, are flat and in no way satisfactory; and where the contrast is exaggerated, where the lights are very bright and the shades very deep, where the transition from one to the other is direct, and the line of demarcation between them is almost visible, the roundness becomes a complete distortion of solidity. This distortion, arising from a vulgar contrast, is sometimes so great as to cause the sitter to disclaim his own picture. The qualifications of an artist are very distinct from those of a mere operator; the former by reason of his qualifications, can associate with gentlemen and the intelligent; the latter can aspire to no higher companionship than with the ignorant and vulgar. But the qualifications in question are attributable in a great measure to a thorough knowledge of light in reference to his art whereby *nature becomes natural*.

If an object be placed so that the light in one direction, whether brilliant or dull, falls perpendicularly upon its surface, the picture will be flat and disagreeable, because there is no contrast; if the light falls obliquely the contrast will be displeasing according to its intensity, because the shadows will be elongated and distinctly marked from the lights. A single light, therefore, can scarcely be said to produce an artistic satisfaction.

Two *equally bright* lights in opposite directions, or rather at directions at right angles to each other, are very objectionable, because either produces a bright circle of light in the eyes, which is repugnant to an artist's feelings from the fact that the picture besides is severely flat for want of contrast.

If light proceed from two directions at right angles to each other, or somewhere in the neighbourhood of this angle, of which one is more brilliant than the other, then it is possible so to arrange the sitter or model as to satisfy a cultivated taste.

The greater the brilliancy of the light, the more *unmanageable* it becomes in the production of that soft merging of light into shade which in photography is so much required. It is, therefore, quite objectionable to use the direct rays of the sun in taking portraits. But during the day these rays proceed from three directions of the compass; in the morning from the east, at noon from the south, and in the evening from the west; from the north alone in the northern hemisphere the rays never emerge. But the northern sky or space is illumined by the direct light from the sun, which by reflection and diffusion has parted with so much of its offensive brilliancy, and is rendered soft and manageable.

The direct light into the glass-house, therefore, must *enter from the north*; this is the light which performs or is to perform the principal part in the production of a photographic negative or positive. Now this single light, which enters from the northern part of the hemisphere, or a portion of it at least, may be softened down by reflection from side screens, and so directed by them upon the sitter as to make any degree of agreeable contrast. With these principles in view the glass-house must be constructed. If the operating room is situated in the highest story of a house, this house ought to be at least as high as the adjoining or contiguous buildings; and the glass window on the roof must be quite unobstructed by chimneys or trees in a direction perpendicular to its surface.

Supposing the ends of the building in which it is required to construct a photographic establishment, face east and west, the following arrangement is one which I would recommend:—Let the southern side wall be raised until it is as high as the ridge of the roof; in like manner fill up to the same height the triangular space in the end wall between the chimney and the southern wall now raised, either on the eastern or western end as it may happen to be; at a distance of fifteen feet from the end wall raise another equally high and parallel with it from the southern side to the ridge of the roof. Next construct a water-tight flat roof beginning at the side and running towards the north about ten feet. Where this terminates introduce the wooden frame (the southern portion inclining to the horizon towards the north at an angle of 45°) to contain the skylight, which may be fifteen feet wide by twelve feet deep, and inclined at an angle of 45° with the horizon and facing the north; the southern part of the frame and the window, therefore, comprehend a right angle.

Where it is practicable, it is as well to have a window in either of the end walls, furnished with sets of tight shutters, about four feet wide and proceeding (in direct contact at the commencement with the part of the skylight nearest the north) downwards to within two feet of the floor. Such side-lights can frequently be used instead of screens; and by the adjustment of the shutters light can be admitted as required, either as regards quantity or direction, that is, from the west in the morning and from the east in the evening. From the lowest part of the skylight downwards, and right across the room, the space is boarded up about four feet deep; and then the remaining part over head is a flat ceiling as far as the northern side of the building. The length of this room must be about thirty feet. The dark chamber of the ordinary work-room may be constructed on the northern side, the window of one being glazed with an orange-yellow coloured glass in order to absorb the actinic rays, and the other with common crown glass. On the

outside of the side windows small platforms are formed for the reception of the printing frames, where no other room can be had separately and especially for the direct-printing department. The skylight and the side-lights have to be furnished with curtains in order to soften or modify the right, which has access, according to the circumstances of the case or the taste of the artist.

The backgrounds are placed in the space beneath the flat roof on the southern side, and so far back as to cut off as much as possible the direct rays upon the head of the sitter. The northern end must be prepared with a greyish coloured paper, the more uniform the better, so as to keep this part as feebly lighted as possible. It is even advisable to have the part where the camera is situated entirely curtained off from the remaining space; by such an arrangement the operator requires no focussing cloth, and the curtains being of some material such as wool, and of a deadened colour, the sitter's eyes are never strained by looking in this direction.

It happens, however, very frequently that photographers cannot direct the construction of their rooms, and that the skylight is inserted directly into the slanting side of the roof. In this case, if the light comes from the north, the room will have a direction from east to west; the sitter being placed at either end according to circumstances. Here only one side light can be used; to compensate the want of a southern side light, a screen moveable on an axis is placed in its stead, which, receiving light either from above or the opposite side, can be made to reflect the same in the direction required.

Where the ridge of a roof of a building is directly north and south, and a skylight has to be constructed on the slanting roof, there seems to be no alternative but to make two skylights, one on either side, furnished with thick curtains on the inside, and on the outside with a tall partition between them, as also one on the southern side to exclude the direct rays of the sun; or to construct a suite of rooms by raising one of the side walls of the building as nearly in accordance with the plan first proposed, with those exceptions only which the nature of the building would demand.

For instance, if the building were somewhat wide, there would be only one side window; and the facilities for printing would not be so great, unless some room could be fixed up with a southern aspect.

The illumination of the background by the light from the skylight just described is uniform, because the construction of the frame admits an equal quantity at the top and at the bottom. The ordinary mode of erecting the southern part of the frame which supports the skylight, in a position perpendicular to the horizon, excludes much of the light and forms a shadow on the upper part of the background, unless a contrivance of reflection over head causes the light to be equally and uniformly distributed.—*Humphrey's Journal*.

INSTANTANEOUS PICTURES.

HUMPHREY'S JOURNAL lays down the following conditions in order to be able to take an instantaneous picture:—

The light must be very bright.

The atmosphere must be very clear, if after rain so much the better.

The lens must be well corrected and capable of working, so corrected, with a large aperture, the larger the better. The collodion, the silver bath, the developer, and intensifier must all be pure and normally good of their kind.

The camera-box must be provided with a means by which the tube can be opened and closed in the fraction of a second, an operation that may be performed with a dexterous hand holding a black cloth.

With such conditions you may succeed, but not always, by proceeding as follows:

Coat your plate with collodion and sensitise as usual, then expose to the view as instantaneously as possible.

Develop with a freshly made iron developer containing 30 grains of the protosulphate of iron to the ounce of water mixed with two drachms of acetic acid and one drachm of alcohol: or the same solution if the protosulphate may be used without the acid.

As soon as the picture appears to assume a slightly foggy film, which will soon be the case where no acid is mixed with the developer, wash thoroughly.

Fix with a solution of hyposulphite of soda, and be careful that the picture is thoroughly fixed. Afterwards wash again and again in order to get rid of every trace of the hyposulphite.

By examining the picture at this stage you can easily see whether it is a negative or not; if all the three gradations of light, middle tone, and shade are present, it is a negative and can be intensified until the shades are quite opaque; if, on the contrary, there are no middle tones, you can never convert it into a respectable negative, all that you can make of it will be a picture in which the contrast is purely black and white, of course as black as you have a mind to make it.

Now intensify, as soon as you are satisfied that you have a picture endowed with the proper conditions, as follows:—Dissolve iodine in a dilute solution of iodide of potassium and dilute until it has a light sherry-wine colour; pour a sufficient quantity of this solution over your still wet negative; move it about on the surface; pour it on and off until the film of the negative begins to assume a slight yellow tinge; then wash thoroughly. The solution by this operation parts with its iodine and becomes decolourised; and it sometimes happens that you require a second manipulation in iodizing, because the first solution was either too weak or too small in quantity.

As soon as the negative is carefully and thoroughly washed pour upon it a sufficient quantity of the following solution:

Pyrogallic acid	1½ grain
Acetic acid	1 drachm
Water	1 ounce
Alcohol	8 drops.

As soon as the plate is well covered with this solution, pour the latter off and add to it six drops of a solution of nitrate of silver, containing forty grains to the ounce of water, and shake it well. Now pour this solution upon the negative, on and off, until the shades are sufficiently dark; if the latter do not increase in opacity to your desire, take another quantity of the pyrogallic acid solution, to which six or eight drops of the silver solution have been added and repeat the operation even to the third time if it should be requisite.

As soon as the negative is sufficiently dark, the plate must be well washed, dried, and varnished.

You will easily remark that the difference between this process and that of taking an ordinary negative must consist essentially and solely in the amount of light which a given lens can concentrate upon the collodion film; for we find, that if a plate be exposed instantaneously without a lens, the actinic action is sufficient to produce a complete blackening over the whole surface when the plate is subjected to the influence of the developer. It appears surprising to those unacquainted with the laws of nature, when they behold that which we denominate an instantaneous picture. But when we consider that light, during the twentieth part of a second, has had time to rush over nearly ten thousand miles, we shall be able to conceive something of this most wonderful phenomenon.

Correspondence.

DOUBLE PRINTING.

SIR,—As I see from your journal that double printing is being brought under notice, I send you two different ways in which I have used it. I have gained so many useful

hints and information from your pages that I am willing to add my mite in return.

The first is a panoramic view of a nobleman's hall. My camera only took views eight inches square, and the only way I could take the view was in two parts of eight inches each. I had seen similar views taken and printed on two separate pieces, but the idea occurred to me to print them both on one sheet and so avoid the ugly seam in mounting them. I did this by pasting a slip of paper on each, running up a line in the building so that each half fit to the other, hiding or shielding one-half of the excited paper while the other half printed; then I passed a universal even tint over the sky—which was white—softening it off at the horizon by a pocket-handkerchief. I gave a quantity so printed at an exchange photographic society, of which I was a member, in or before 1857, about six years ago.

The other is a moonlight view on a river. The first printing was from an intense negative, so as to give sparkling high lights on the trees and bank. When printed deeply on another glass, I painted a round moon in such a place that it came partly behind the branches of a tree: the second moon I painted to be its reflection in the water; some high lights I preserved on the trees and banks by cotton wool. It is some four years ago since I did them.

My opinion of double printing is that it ought to be used only with great judgment, not an indiscriminate use made of it. I think that the general adoption of it by persons of all degrees of attainments would lead to the production of very questionable things in the way of good taste. How far I have succeeded in the moonlight effect, I have laid myself open to criticism. In the panoramic view I looked upon it as a necessity.

I work by the collodio-albumen dry process, and have—may I say invented?—a stand for developing, or other purposes, which, for simplicity and convenience, I think cannot be surpassed. My plates are 10×8; into a 12×9 dish I place a preserve or marmalade jar, six or seven inches in diameter; in the jar I place a round-bottomed or common plain stop bason, and it gives me a large ball and socket hinge, that I can elevate or depress on any side, and to any angle, allowing the plate to develop more or less on any side, or it may be perfectly level.—Yours, truly,
THOMAS KIRBY.

Trentham.

[The panoramic picture shows admirably the value of the principle in question. The moonlight is not so successful. We doubt very much the legitimacy of the attempt. It is certainly one which will rarely succeed.—Ed.]

ON THE MOTION OF CAMPHOR TOWARDS THE LIGHT.

SIR,—In a letter published in your journal of the 17th April last, I endeavoured to show that Dr. Draper's claim to the discovery of the true theory of the motion of camphor towards the light could not be supported, and that the result of his experiments, as republished in 1844, was merely to multiply the phenomena, and to leave the theory as it was.

Dr. Draper has since published a letter in the *Philosophical Magazine*, in which he affirms that I admit that he published the true explanation of these motions in 1840; and he also accuses me of having founded my remarks on experiments of his made in 1837. I have replied to these charges in a letter to the *Philosophical Magazine*, the substance of which I hope you will allow me to repeat here; but I must be permitted to remark that the later, as well as the earlier experiments, as given by Dr. Draper, equally fail to explain the true theory, and that with the fine opportunity of correcting them, afforded by the republication of the whole in 1844, it is incredible that they should have been presented without note or comment, and illustrated with new engravings, had the author been at that time in possession of the true theory.

In my letter to the *Philosophical Magazine*, I state that I have never had the slightest intention of misrepresenting

Dr. Draper, or of detracting from the merit due to his industry and skill. But I deny that the paper which he published in the *Philosophical Magazine* in 1840, or his volume of 1844, contains the true theory of the motion of camphor towards the light, or that I ever admitted that it did so. The former contains a question which, had it been followed out, and properly tested by experiment, might have led to the true theory; but that it was not thus tested is proved by the fact that in the volume of 1844 it was again published as a question, and nothing more.

I now leave my claims, and those of Dr. Draper to be settled by reference to my papers and his volume. But I think it will be admitted that the latter, full as it is of details of ingenious experiments, leaves one as much in doubt at the end as at the commencement, and cannot possibly be considered as the earlier and later steps of a successful inquiry. Indeed, it is so difficult to trace any consecutive steps, that the volume was viewed by me as a whole, and as containing the latest revised opinions of the author.—I remain, &c.,

C. TOMLINSON.

King's College, London, June 9th, 1863.

Proceedings of Societies.

THE AMERICAN PHOTOGRAPHICAL SOCIETY. FORTY-SEVENTH MEETING.

The Society held its regular meeting for April, on Monday, 13th inst., at the University, President DRAPER in the Chair.

The Minutes of the last meeting were read by the Secretary, F. W. GEISSENHAINER, Jr.

Mr. RUTHERFORD said that the statement made by Prof. Joy at the last meeting, that he had succeeded in photographing the entire visible spectrum, was erroneous. On the contrary, he had never been able to obtain any photographic effect, beyond the middle of the green, although he had submitted to a strong light a most sensitive surface.

Printing and Toning.—The subject for the evening having been taken up,

Mr. BURGESS inquired what was the best manner of applying the silver solution to the paper for albumen prints. His practice had been to use the ammonia-nitrate solution:—Take eight ounces of water containing silver and convert one ounce into a solution in the ordinary manner, and then mix it with the other seven ounces, and filter. Float the paper five minutes, and dry and print it; sometimes he submitted it to the fumes of ammonia.

Col. PIKE said that recently he had used for his floating bath forty grains of silver to the ounce of water, into which he dropped a few drops of concentrated ammonia. He had been experimenting with nitrate of ammonia, and had succeeded in the following manner:—He dissolved three drachms of nitrate of ammonia in a few drops of water; then in half an ounce of water he placed ten grains of nitrate of silver. He then added concentrated ammonia enough to make it turbid, and threw down all the silver he could without clearing it. This he added to the nitrate solution, and it cleared it at once, so that it was unnecessary to filter it. He used this with paper salted with only one grain to the ounce, and it made fine prints which toned up admirably. The addition of ammonia to the nitrate of silver bath seems to accelerate the printing; he inquired what was the chemical reason for this?

Professor SEELY said that he had not yet found any satisfactory exposition of the action of ammonia. He did not see that nitrate of ammonia would be of any service, unless it is a coagulator of albumen. It would seem theoretically that it would be better to wash away the nitrate of ammonia and redissolve with ammonia alone. There are several objections to a weak solution of silver with albumen paper. In the first place, the albumen surface is more liable to be disturbed. Adding some substance to coagulate the albumen might overcome that difficulty. With the albumen perfectly coagulated, a solution of three to five grains could be successfully used, in all probability, as an experiment. Still it would not be practicable for real business. The nitrate of silver solution would rapidly deteriorate in strength. An iodide or a bromide which would be little soluble in water would permit a weaker solution of

silver than the ordinary nitrate bath. Another question connected with the subject for the evening was the new fixing salt, the sulpho-cyanide of ammonium. He was not inclined to recommend it. One objection to it is that it is poisonous. The sulpho-cyanide of potassium, which is similar to it in its action, is less poisonous probably; and it is very easily and cheaply made. Take two parts of the yellow prussiate of potash and melt with one part of sulphur, and it produces the sulpho-cyanide of potassium contaminated with a little metallic iron which may be filtered off; or, boil flower of sulphur in a solution of cyanide of potassium until it begins to turn yellow. Still the advantages from it are not sufficient to warrant much consideration of these experiments.

The PRESIDENT remarked that it had been asserted that the sulpho-cyanides were not poisonous, and probably because one of them existed in saliva; but it was not a constant ingredient, and when there, it was in very minute quantities; so that he did not regard this a justification of the assertion.

Professor SEELY suggested another objection to both these salts, that any excess of alkali would take the albumen right off the paper. It is stated also, in the PHOTOGRAPHIC NEWS, that it yellows albumen paper.

Mr. BURGESS inquired what was the best quantity of silver to be used in silvering paper. He had used from 90 to 120 grains to the ounce.

Col. PIKE gave his toning process as follows:—Put in stock-bottle No. 1, 60 ounces of water and 100 grains of acetate of soda, or 75 grains each of acetate and phosphate of soda. In stock-bottle No. 2, put 1 ounce of water and 15 grains of chloride of gold. In stock-bottle No. 3, put 15 grains nitrate of uranium to 1 ounce of water. This will suffice for 150 pictures. Take from stock-bottle No. 1, 8 ounces; from No. 2, 2 drachms, to be neutralised with carbonate of soda; from No. 3, 2 drachms, also to be neutralised; mix and filter, and it is ready for use. For a fixing bath I use $\frac{1}{2}$ -pound hyposulphite of soda in 20 ounces of water. This bath must never be used twice, or it will yellow the whites of the pictures.

Mr. MASON had used a very similar process with success. For the gold solution he used 30 grains of chloride of gold in 6 or 8 ounces of water.

Mr. CRUM had also used a similar process. For a silver solution for floating albumen paper, he had used from 120 down to 40 grains with nearly equal results. First introducing in it ammonia to form a precipitate, and then clear up, he added a few drops of nitric acid, and about a drachm of alcohol to eight ounces of the solution. He thought the alcohol tended to preserve the albumen surface.

Mr. MASON exhibited some pictures taken by Mr. Masterton (which were commended by several members), and inquired the process.

Mr. MASTERTON said that he used a nitrate bath of 60 or 70 grains, fumed the paper about twenty minutes, and floated it about three-quarters of a minute. He did not use ammonia-nitrate, but generally put a little citric acid into the solution.

Col. PIKE suggested washing prints with boiling hot water.

On the motion of Mr. BURGESS, the subject of Fixing and Toning was made the subject for consideration at the next meeting.

Heliochromy.—Mr. TILLMAN read a paper on Heliochromy. (See p. 270.)

Stellar Spectrum.—In reply to an inquiry by Mr. Tillman, Mr. RUTHERFORD said that he was still engaged in observing the location of the lines in the stellar spectrum; and had so improved his apparatus as to see the lines with greater facility and locate them with greater accuracy than before; having added a prism so that he could see in the same field the stellar spectrum, the scale of measurement, and also the chemical lines reflected from a spirit lamp; by that means guarding against the slight movement which took place even with the finest possible slit in the spectroscope. He remarked that he had now ascertained that Arcturus presents the lines of the solar spectrum in the same places, proving a similarity between its constitution and our Sun. If made of the same materials, and if the nebular hypothesis be true, were they made of material in the same neighbourhood? If so, is Arcturus straying away from its former, our Sun, or does it still belong to the same neighbourhood in the Universe, in space? We know that other stars are not of the same materials, but there is a striking difference between them. Here Chemistry reveals a connection which Astronomy has failed to show.

Mr. TILLMAN, after alluding to the fact that the dissimilarity

between the stellar spectra seemed to conflict with the nebular hypothesis, remarked that the most splendid astronomical analogy of our time, the most sublime discovery since the days of Kepler, the law of Kirwood, an American, that the square of the number of revolutions of each planet upon its axis per annum is as the cube of the diameter of its attracting sphere in the nebular hypothesis, had been alluded to by the late Prof. Nichol as confirmatory of that hypothesis. He could only hope that some explanation might be found for the facts discovered by Mr. Rutherford, which would make them consistent with that view, because it seemed to him to give, above any other theory, the most exalted idea of creation and the Creator.

FORTY-EIGHTH MEETING.

THE Society held its regular meeting for May, on Monday, 11th inst., at the University; L. M. RUTHERFORD, Esq., Vice-President in the chair.

Toning and Fixing.—This being the subject for the evening,

Mr. BURGESS started the discussion, by inquiring what proportion of hyposulphite was generally used in solution? He used 1 ounce of hyposulphite to 8 ounces of water, and found that proportion to work successfully.

The CHAIRMAN asked if the inquiry was suggested by any misgivings on the subject of that being the proper proportion?

Mr. BURGESS said not; that he merely wished to know what the practice of others was.

Mr. CRUM mentioned that the proportion he sometimes used was 2 ounces of hyposulphite to 10 ounces of water. So far as his observation was concerned, he questioned whether there was any staple formula. He thought, as a general thing they used too little hyposulphite in fixing prints.

The CHAIRMAN wished for some light on the question; what was the chemical action of toning—whether the metal gold really took the place of the metal silver in the print, and if that was the theory what produced the result.

Professor SEELY said such was the theory, but still the proof could not be of the most positive character. The print was changed by the gold; it was pretty certain the gold was deposited there, and if deposited there, we could not but suppose it took the place of the silver. In the Daguerreotype process, we knew that the gold from the gilding solution was deposited in the metallic state upon the silver. The silver of the collodion negative we knew to be in the metallic state, and when a solution of chloride of gold was poured over it, the gold was removed and the image took the same colours as were seen in toning paper prints.

The CHAIRMAN had been struck by two facts that led him to doubt there was any metallic substance, properly called, in the construction of the print, when finished. In the first place, the fact that the print, or material of which the image was formed, disappeared, leaving a white surface, which seemed to be inconsistent with the idea of there being present one of the royal metals, particularly gold, which did not oxidise and still less evaporate. The other fact was that, in experiments with paper treated in the ordinary way, and made as dark as possible, he had found it no better conductor of electricity than a piece of plain paper. We knew that gold and silver, in the minutest shape to which the gold-beater could reduce them, were good conductors; but on photograph paper the spark jumped it as it would a vacant space. These two facts threw suspicion upon the existence of gold or silver in the print, in a metallic form. About two and a half years ago he had two hundred prints made of the surface of the moon, about four inches in diameter—beautiful prints, executed by one of our best artists. They lasted perfectly well for two years; and at the end of that time began suddenly to deteriorate, until now they were almost white paper.

Mr. BURGESS thought that albumen paper was more likely to retain the image than plain paper.

Mr. CRUM was of opinion that the metal must be in the print, for when we chlorodise metal we knew it was there in existence; and the experience of every operator was that, as the gold was taken up from the bath by the prints, the toning depreciated; so that while the first prints immersed in the toning bath printed very rapidly, gradually, as the gold became absorbed, they toned slower and slower, until the prints ceased to tone at all, and no gold was left in the bath. The question then arose, what became of this gold? It was certainly an indestructible element; it could not evaporate, and it must be in the print. By paying special attention to the toning—using sufficient gold and good chemicals—he found that his

pictures did not fade, but rather improved by age. He had abandoned the use of plain paper altogether, except for photographs coloured in water, finding that albumen paper was much superior.

The CHAIRMAN inquired if any gentleman had tried the formula of their late secretary, Mr. Thompson, by using brass as a substitute for gold. He had received from Mr. Thompson some beautiful prints on albumen paper, which he stated were brass toned.

Mr. CRUM did not think they would last any length of time.

Mr. TILLMAN thought the question an important one to consider; of course there was no similarity between brass and gold, except in the colour, and the question was, whether that peculiarity in the brass which presented the yellow ray was not the very quality or virtue which was necessary when used in the art. He was not prepared to discuss this, but it opened a wide field of inquiry.

Mr. BURGESS said that he understood that another substance, bichloride of mercury, had been used, and with great success so far as getting colour, but the pictures were found to fade soon. Mr. Anson had told him he used it for a time, but returned to gold again.

Mr. LOOMIS stated that he had, in a number of experiments made, produced very vivid tones with bichloride of mercury; there was no difficulty in giving any required tone of red, to the deepest purple; but he had never succeeded in producing any prints in this manner that would stand. He found that he could instantly restore prints which had faded almost white, to a purple tone, with bichloride of mercury. He also found that almost any print he had ever seen could be removed with the fumes of nitric acid. That fact seemed almost conclusive that there was no metallic gold in the print.

Mr. TILLMAN suggested that if any one felt disposed to try Mr. Thompson's formula of using brass, instead of gold, he had better use the oreide, which was the purest kind of brass.

Prof. SEELY said that the bichloride of mercury process was by no means new. He had published an account of it eight years ago, and his experience was the same as others, that the pictures were not permanent. As to toning with brass, it was evident that if the gold were used in an alkaline condition, no zinc or copper of the brass would be held in the solution.

Electro-Daguerreotypes.—Mr. PLUNKETT presented for the inspection of the Society some electrotypes, made from a daguerreotype, which were very perfect. He stated that the copper was deposited on the daguerreotype plate, and one of those produced was the ninth one taken. There was no difficulty in separating them. He passed the plates over the fumes of boiling beeswax.—*American Journal.*

BRINGING HOME THE MAY.—We learn from various sources that Mr. Robinson's charming picture is the cynosure of all eyes, and the chief attraction at the French Exhibition. M. Lanlerie, secretary of the French Society, in a private letter, speaks in the highest terms of the admiration it receives from French photographers. *La Lumiere* styles it the pearl of the Exhibition, and thus describes it:—"Bringing Home the May" is a large composition 40 by 16, illustrating an English custom. Young girls and children are engaged in gathering the wild May flowers, or are carrying large burdens which they have just gathered. Their features are lighted up with mirth and gladness, as they enjoy themselves amid the beautiful foliage. Every part of the picture is perfectly made out and distinct down to the smallest blade of grass, and whilst the picture has been produced from at least three negatives, there is perfect harmony and keeping, the whole being rendered with exquisite perfection. This fine production is by Mr. H. P. Robinson, of Leamington; and although it may be regarded as a *tour de force*, it is one more proof, amongst thousands, of the exhaustless resources of photography, and illustrates the perfect success which crowns the skill and patience of the artist when thus applied." We have before stated that this exquisite picture is from seven different negatives. That there is no evidence of patchwork, is illustrated by M. Gaudin's conjecture. Mr. Robinson is engaged upon another large composition, and we think the fact that an artist engaged personally in a very extensive portrait business, which absorbs almost all his time and energies, still produces yearly, at least one such composition as that we have noticed, suggests that if the work in question be a *tour de force*, it is one which need not be an isolated example if the artist had more time at his disposal.

To Correspondents.

W. H. T.—Good glue, clean and freshly made, may be used for mounting photographs with advantage. The Scotch glue is generally used by professional mounters.

M. P. has accidentally mixed his silver solution and his developing solution together and wants to know what he shall do with them. The iron will reduce the silver into a metallic state. The completeness of the operation may be facilitated by boiling in a glass flask. When all the silver is reduced, which may be ascertained by adding a little of a solution of common salt to the mixed solutions, and observing whether any turbidity is caused, indicating the presence of unreduced silver, the grey precipitate at the bottom, which is metallic silver, may be well washed, and reconverted into nitrate of silver as we have often described. 2. We do not find the rosin cement, to which you refer in your letter; if it were made according to the formula given on page 195, *PHOTOGRAPHIC NEWS*, Vol. VI, it would be right. 3. The shellac varnish is right; but it must not be used over the rosin cement as it would probably partially dissolve it. You may use either alone for vessels to contain photographic solutions. 4. Yes; it is right. 5. Also, right. 6. Your bath will do if you have made it so that it will not leak. 7. Wash out the bath with dilute cyanide solution to remove the traces of reduced silver, and rinse well. 8. A bath of pure gutta-percha may be used safely, especially if the bath be not kept in it constantly.

FORMIC ACID.—A Correspondent, signing "Charity," writing on this subject, says:—"Since Mr. Henry Claudet introduced this active acid to developing, innumerable "mares' nests" have been, and will, doubtless, be discovered; still, it is just possible that some of them may ultimately turn out useful to the art. With this hope I procured no less than six different kinds of this acid manufactured by as many different means, and all from different sources. I find on trial that they all approximate in result to that in the formula published by Mr. Claudet, so closely that it would only amount to plagiarism of his communication to trouble your readers with details. K. Staunton has restated the process in a recent number with slight variation, and the process I think merits all he said in favour of it. However, each respective operator will and must determine for himself the quantity of acid necessary for the production of the best pictures by actual experiment; and as each operator considers himself superior to every other in some particular point, each may assist all by contributing some slight variation. I find the period of exposure reduced certainly one-half.

THE CAUSE.—The spot in the print you forward is caused by some imperfection in the albumen surface, or rather by the absence of any albumen. Its absence may be the result of imperfect preparation, or of something having removed it from that place before the paper was sensitized.

AN AMATEUR.—Of the two lenses by the first maker you name, the 1 B and 2 B, the latter is of longer focus and larger diameter than the former. It gives better definition and greater rapidity, and is, therefore, better. Where the room is long and the cost not of vital importance, it is decidedly preferable. 2. We do not know of any half-plate portrait lens for £22s.; such a lens cannot be worth much. The 1/16 lens of the English makers is generally a very first-rate instrument, and covers a whole plate well. 3. We have not had opportunity of comparing the two lenses you name, and cannot therefore give an opinion.

S. P. C.R.—Before adding fresh gold to an old lime toning bath, neutralize with carbonate of lime, using hot water.

H. G., Brompton.—The chief fault in the lighting of your figures is too much top light. With a lofty room you can afford to extend the opaque part over head still further. You also under-expose a little.

W. WILSON.—Whilst there is still room for improvement in your work, it is decidedly up to the average. You need not fear disgracing the art if you continue to do your best. The photography generally is good; perhaps there is a slight tendency to under-exposure. Study the cards of the best artists, and endeavour to acquire a little more ease in posing. In No. 1, the background is faulty, in the profile fireplace, &c., being of a much lighter colour than the background which represents another wall of the same room. With a trifle more exposure No. 2 would have been good. No. 3, a stiff position, but the rest pretty good. No. 4, good, with the exception of the perspective being false. 5. When you vignette the full length figure, the feet should be either entirely cut off, or quite retained; 6 would have been good with a little more exposure; 7 good; 8 also good; 10, photography good, accessories bad; 12, the same as last; the point of sight in the painted portion of the background, and in the photograph are not the same, and the perspective glaringly incorrect. We have spoken plainly of the faults in your work, but would speak encouragingly on the whole. With patience and care you will make a first-rate photographer.

AN AMATEUR (No. 2).—It will not be safe to use a gutta-percha bath which has been employed for hypo, for a nitrate of silver solution, even after any treatment. If you choose to risk it, let dilute sulphuric acid remain in the bath for a few hours, and then wash well with plenty of water and a mechanical friction.

SEA-SIDE.—When the plate has been covered with glycerine, and drained a short time, it may be placed vertically in the plate-box without injury. Wash again before fixing.

A. HARMER.—We see no reason at present to believe that the demand for card-portraits will abate. 2. Probably, a developer of one-fourth the strength will answer better in your hands.

A TWO YEARS' SUBSCRIBER.—Send us a specimen of the defect, and we shall be able to help you.

H. G.—See report, in our "Scientific Gossip."

AN ENGRAVER.—The method of producing the "ghost," at the Polytechnic, as we believe, the invention of Mr. Durck, and is patented, we understand. The specification is not yet published. We believe it is the result of reflection, not of optical projection. The details may be easily conceived, but we cannot enter into them here.

E. S.—The brownness you describe is simply fog. Use more citric acid in the pyro solution, or use the iron intensifier we recently described. When the fog is irregular, it is probably due to imperfect washing between the various operations. The use of a solution of iodine before intensifying will generally prevent the deposit. 2. The prints becoming of a pink colour in the back is generally due to toning in white light, causing a reduction of the gold throughout the paper, instead of on the image only.

A. Z.—We should attribute the spots in question to the albumenized paper. We only once met with a similar result, which disappeared at once on changing the paper.

SHEFFIELD.—Where rapidity is not an object, we should prefer a single lens

to a portrait combination for landscapes. But, for instantaneous work, a portrait combination is decidedly the quickest, and the definition, in our estimation, more satisfactory than can be obtained with an ordinary single lens with an aperture sufficiently large for instantaneous work. We recently made a trial of a single lens (aplanatic), and a portrait lens of the same equivalent focus, each six inches; the stop in each three-eighths of an inch (to have been equivalent stops that in the quarter-plate being between the lenses should have been one quarter of an inch). In both the perfect definition covered more than a stereoscopic picture. The single lens required an exposure of twenty seconds to produce a good negative; whilst the portrait lens required ten seconds for the same result. The light was not bright. 2. Albumen, in the collodio-albumen process, has several purposes; but it decidedly gives vigour there, and in almost every photographic process in which it is used. 3. A single lens to cover 18 by 18 should be of about 30 inches focus. 4. We have not used the collodion in question. If it fail to give intensity, either intensify or try another sample. We do not like to see over-much intensity in the sky.

C. L. O'BRIEN.—The prints enclosed in your note are, moderately good; but it is quite impossible to form an opinion of your qualifications for a professional engagement upon such evidence. It is comparatively easy for anyone to produce two or three moderately-good prints, if everything be prepared for them, and in good working order. A good printer must not only be familiar with all the manipulations in printing, such as sensitizing, exposing, toning, fixing, washing, &c.; but he must be able to prepare all his solutions, to know when they are in good or bad condition, and the causes and remedy for the latter. Also, how to deal with various difficulties, and meet the requirements of various batches of paper, and various qualities of negatives. You will readily see that we can form no opinion on these points from examining a few prints.

PERPLEXITY.—The stain has every appearance of having arisen from irregular development. The developing solution, instead of covering the plate evenly at one sweep, has run back from the edge of the plate in greasy, irregular, branch-like lines and patches. If this be the cause, as we suspect, add a little more alcohol to the developer, and manipulate more carefully. If, as you state, the markings show on the plate on removing it from the nitrate bath, they probably arise from using a collodion giving an impervious horny film. In such case add a drop of distilled water to each ounce of collodion.

SOL.—The solution of chloride of gold which you have may be used according to Ommegeanck's formula, taking care to preserve the proper proportions. 2. Chloride of silver cannot be converted into nitrate by any direct process; it must be reduced to metallic silver first.

R. H.—You may procure good lenses at many photographic establishments, but we should recommend the best London makers. The size and price must depend on the purposes for which they are required. The meaning of coincidence between the visual and chemical foci is in result, that when you obtain a sharp image on the ground glass, you will also obtain a sharp image on the sensitive plate when placed in the same plane; and unless the corrections in achromatizing the lens are such as unite the visual or illuminating rays, and the rays producing chemical action, this coincidence does not exist. It will be desirable either to get the assistance of an experienced friend, or to consult our advertising pages, and call upon the most respectable opticians, and state your wants. Chloride of gold will keep in solution. It is as well kept in the dark. Send us specimens of your difficulties or defects in printing, and we can advise you. Toning and fixing generally reduce the print somewhat, and it is necessary to over-print sufficiently to allow for this. The firms to whose advertisements you refer do not print from the cards sent, but from negative copies of them. There are instruments for measuring the intensity of light, which you may obtain of some philosophical instrument makers, but experience is the best guide. To copy a drawing the same size your camera must be drawn out to twice the equivalent focus of the lens, and be placed at the same distance from the drawing which the lens is from the ground glass. An achromatic triple lens is the best for copying. The solar camera is intended for producing enlarged prints from small negatives. It has been repeatedly described in our columns, and would require too much space for description anew in this column. You will learn particulars of any dealer. We can draw invidious distinctions as to the best producers of any photographic requisite in this column.

A NOVICE.—The apparatus in question is not suited for portraiture. We have not tried it ourselves, but should have more faith in the lenses of the best London makers. The enlarged specimens appeared to us to have considerable distortion. Mr. Scaife's Pistolgraph is a clever little camera and lens, giving very rapid results. The lenses are made by Dallmeyer.

SEVERAL CORRESPONDENTS in our next.

ERRATUM.—Mr. Ross desires us to state that his small lens for medallion portraits possesses an aperture of six-and-a-half-tenths of an inch, not eight-tenths, as stated in the report of the London Photographic Society, in our last. With this aperture it works in a fourth of the time of his card lens.

Photographs Registered during the Past Week.

MR. JOHN HAWKE, 531, Union Street, Stonehouse, Devon,
Three Photographs of Mrs. Clara Lucas Balfour.

MR. A. S. WATSON, 2, Regent Road, St. Yarmouth,
Two Photographs, Officers of East Norfolk Militia.
Photograph Mr. J. Smith.

MESSERS. HILLS AND SANDERS, 16, Dorn Market Street, Oxford,
Three Photographs of the Very Rev. Richard Chenevix Trench,
D.D., Dean of Westminster.

MESSERS. MOIR AND HAIGH, 1, Lower Seymour Street, Portman Square,
Photographs of Sir Francis Crossby, M.P., James Stanfield, M.P.,
Richard Roberts, C.E., Sir Rutherford Alcock (British
Ambassador at Court of Japan), Count de Lavradio
(Portuguese Minister in London).
Photograph of Medical Officers at St. George's Hospital.

MESSERS. HELSBY AND CO., 34, Church Street, Liverpool,
Photograph of a "Patagonian Chief."
Two Photographs, "Group of Llamas."
Photograph of "Ruins, Tia-Huanaco."

Two Photographs of Rev. F. J. Sharr.

MESSES. FORTUNE AND CO., 29, Golden Lane, Dublin,
Bottle Label.

THE PHOTOGRAPHIC NEWS.

Vol. VII. No. 250. June 19, 1863.

CONTENTS.

	PAGE		PAGE
Note on the Results of Mr. Glaisher's Photometric Observations.		Aerial Photography	297
By John Spiller, F.C.S.	289	Annual Report of the South London Photographic Society	297
Photographic Chemicals	289	Correspondence	297
On Developing the Photographic Negative. By M. Aug. Testelin	290	Proceedings of Societies	298
Dry Collodion and Dry Processes. By Dr. D. Van Mouckhoven	292	Photographic Notes and Queries	299
Microphotography, or the Art of taking Enlarged Copies of Photographs.....	293	Talk in the Studio	300
A Few Words on Portraiture	295	To Correspondents	300
Dialysis	296	Photographs Registered during the past Week	300

NOTE ON THE RESULTS OF MR. GLAISHER'S PHOTOMETRIC OBSERVATIONS.

BY JOHN SPILLER, F.C.S.

AFTER reading the interesting account of Mr. Glaisher's last balloon ascent, as given by him in the *Times* of the 22nd April last, I was induced to make some experiments with the view of imitating, if possible, the extraordinary conditions under which that gentleman observed, at an altitude of three miles, and in the clear atmosphere above the clouds, that surfaces of sensitized photographic paper were not so much darkened in the course of half-an-hour's exposure to direct sunshine as were similar sheets by one minute's solar action within the grounds of the Royal Observatory, Greenwich. Several causes have been assigned by way of accounting for these remarkable results, and some useful suggestions followed the announcement of the full particulars by Mr. Glaisher at the meeting of the London Photographic Society, on the 5th May. It was on this occasion stated that the thermometer indicated 21° Fahr., and that the dew point was below zero at the time of exposure. These conditions, at the altitude mentioned, are indicative of an exceedingly dry and rare atmosphere, in which rapid evaporation must occur, and the cold would be sufficiently intense to freeze very quickly any traces of water still lingering in the pores of the paper. Absence of hygroscopic moisture appears then the probable explanation of the facts observed. The verification of this opinion is, I believe, contained in the experimental results which have now to be described.

Sheets of albumenized and plain salted paper were sensitized respectively on nitrate of silver in the usual manner, and, when air-dried, were cut into slips for comparison.

1. Exposed to bright diffused daylight in a glass globe filled with air at the ordinary pressure.

2. The same arrangement; the air in the globe being exhausted by the aid of an ordinarily good air-pump, until the vacuum gauge stood within half an inch of the height of the barometric column.

3. Similar experiment to No. 2 in all respects, excepting that a piece of moistened filter paper was placed near, but not in contact with, the sensitized paper inside the glass globe.

4. Also similar to No. 2, but with a supply of chloride of calcium to absorb water from the rarefied air.

5. Without pumping out the air the paper was kept for two hours in the dark under a glass receiver, within which was a shallow dish containing sulphuric acid to absorb the moisture. At the end of that time, exposed to light beside the ordinary paper under glass for comparison.

6. The papers were kept some time in an atmosphere dried by quicklime; then exposed to light as before.

7. Slips of the paper were dried thoroughly by the application of heat, and then exposed to light under pressure between two plates of glass; similar papers in ordinary hygroscopic condition serving for comparison.

The results were as follows:—

No. 2 darkened more slowly than No. 1, and exhibited, in the case of albumenized paper, a pale lilac tint, instead of a rich chocolate or purple brown.

No. 3, in the moist vacuum, was affected by light in the same manner, and as quickly, as No. 1.

No. 4. The action of light was very much retarded, more so than in No. 2.

Nos. 5, 6, and 7, were but slowly affected, the colour of the papers being generally similar to No. 4.

The plain chloride of silver paper, and other sheets prepared with Swedish filtering paper, exhibited, in different degrees, the same general result as the albumenized surfaces.

The effect of exposure to intense cold, or artificial freezing mixtures, remains yet to be investigated, and it cannot be said that the effects observed in the course of my experiments were so decisively marked, although doubtless of the same character, as those described by Mr. Glaisher. The influence of moisture in increasing the sensitiveness of these photographic surfaces has been many times pointed out by others as well as myself, and was particularly alluded to in my "Description of a Desiccating Box for Preserving Sensitized Paper," read on the 5th March, 1861, at a meeting of the London Photographic Society. In using this apparatus I found that the sheets of sensitized paper could not be employed for printing in the unusually dry state in which they were taken from the box, but that a short interval, for re-absorption of hygroscopic moisture, must be permitted before laying them in contact with the negative.

The addition of nitrate of zinc as a deliquescent agent was tried under the impression that this substance would have furnished a more uniformly sensitive paper under all circumstances; but the result of such admixture has not proved this to be the case. The use of a bath of fluoride of silver, instead of the nitrate, for sensitizing the paper would doubtless have the effect of retarding the evaporation of water from the prepared surface, and might thus afford a means of producing papers of more definite character. I am now engaged in investigating this point, and will, if successful, communicate the results.

In the course of these experiments I have had many opportunities of noting the remarkable degree of expansion which coincides with the absorption of moisture. The dimensions of the paper frequently varied as much as one-fiftieth in the transition from moist to dry, a point which does not appear to have been sufficiently considered in attempting photometrical determinations upon paper tablets.

Chemical Department, Royal Arsenal, Woolwich.

June 9, 1863.

PHOTOGRAPHIC CHEMICALS:

THEIR MANUFACTURE, ADULTERATION, AND ANALYSIS.

URANIUM is of value in optical researches, not only on account of the sensitiveness of some of its salts to light, but

because many of its compounds possess the curious property of fluorescence, or rendering visible the chemical rays of light, by converting them into rays of a less refrangibility. Its properties in this respect have been well investigated by Professor G. G. Stokes. A beautiful transparent yellow glass, with a green tinge, is frequently met with in commerce, being largely used for ornamental purposes. If this glass be examined by candle-light, it will be seen to be perfectly transparent, and to have no green tinge, but if looked at in daylight, especially if the sun shines on it, it will become almost opaque, reflecting back a strong greenish-blue light. On concentrating a beam of sunlight on to a thick piece of this glass by means of a lens of one or two inches focus, the cone of light will be traced out through the glass by a strong luminosity, appearing as if the particles of the glass were in some degree opaque to the light. This effect is caused by the invisible chemical rays present in the incident light being lowered in refrangibility, and thereby converted into luminous rays by the action of the uranium compound in the glass. This effect may perhaps be better understood by some of our readers, if we consider the uranium glass to have phosphorescent properties, and to be excited into luminosity by the chemical rays of light.

If a slab of uranium glass be employed as a screen for receiving an image of the solar spectrum, especially if the latter be pure enough to show the fixed lines, the appearance is very striking. Where the visible spectrum falls no particular effect is produced, but as the eye travels along the band of colours up into the blue and indigo end, the lines in these parts, difficultly visible under ordinary circumstances, shine out with unaccustomed brilliancy. The line H, barely detected by the unaided eye, is remarkably prominent, and beyond, far into the regions of darkness, are seen groups of lines, some as fine as spider threads, some like great black bands stretched across, cutting almost through the slab of glass, which glows through its whole body with an indescribable phosphorescent light, except where the jet-black lines intersect it. If the prismatic apparatus be of quartz, and a fine summer's day be selected for the experiment, the length of the solar spectrum will be apparently increased four or five fold. Starting from H, near the limit of the visible spectrum, but almost the commencement of the invisible part, we see the broad band *k*, the curious group of four nearly equidistant lines, *m*, the somewhat allied band *n*, and then a host of other lines to which physicists have given letters, until the alphabet itself proves too humble for its requirements, and other lines and groups are detected faintly following *x*, *y*, and *z*. Professor Stokes, who has thoroughly investigated the action of uranium compounds upon the higher rays of the spectrum, considers that for some purposes a slab of uranium glass is not the most convenient for purposes of observation. Glass must be viewed in one particular position, in order to see the lines with the best effect, and in many cases it would be more convenient to have a screen prepared by means of a highly fluorescent powder applied like a water-colour on paper, which could be viewed in all directions indifferently. The professor states that he has long regarded it as a desideratum to obtain by precipitation an insoluble or sparingly soluble salt of sesquioxide of uranium, which should be as fluorescent as the best salts of that base, and which might be treated as a water-colour. He has recently succeeded in preparing such a salt, though not by direct precipitation. The ordinary phosphate obtained by precipitation is only slightly fluorescent. If, however, this salt, with as much water as remains when it is washed by decantation, be put into a saucer, a little free phosphoric or sulphuric acid added, and then crystals of phosphate of soda, phosphate of ammonia or borax be added in excess, the original salt is gradually changed into one which is powerfully fluorescent. The change seems to take place most rapidly with borax, but as an excess of this salt is liable to decompose the fluorescent salt first formed, it is better to

employ a phosphate. The quantity of acid should be sufficient to leave a decided acid reaction when the liquid is fully saturated by the alkaline phosphate employed. The change may be watched by observing, from time to time, the fluorescence of the salt by daylight, with the aid of absorbing media. It is complete in a few days at furthest, when the salt is ready to be collected. This requires precaution, as the salt is quickly decomposed by dilute acids (and, accordingly, by its own mother-liquor, if diluted), and even, though more slowly, by pure water, with the formation apparently of the original phosphate. It is also decomposed,—at least, in time—by alkaline carbonates, with the formation of a beautiful yellow non-fluorescent salt, resembling the precipitate given by alkaline carbonates in salts of sesquioxide of uranium. The salt may be collected by adding at once, instead of water, a saturated solution of borax, in quantity at least sufficient to destroy the acid reaction. The salt is then poured off in suspension from any undissolved crystals of the alkaline phosphate employed and collected on a filter. A pressed cake of this salt, or a porous tile, upon which the salt is spread, having been moistened with a solution of borax, forms an admirable screen. It shows, of course, the visible as well as the invisible rays—the former by ordinary scattering, the latter by fluorescence.

Hitherto the only uranium salt used in photography has been the nitrate. This seems to be rather an unappropriate salt; for since the action of light upon it is to reduce a higher to a lower state of oxidation, it is clearly inadvisable to employ as the sensitive surface a salt containing so much oxygen as the nitrate. Analogy with other photographically sensitive compounds would lead us to propose that some organic compound of uranium should be used, as, for instance, the acetate, which is likely to be far more acted upon by light than the nitrate. Acetate of uranic oxide is prepared in the following way:—Nitrate of uranium is placed in a porcelain dish and gently heated with a spirit lamp. It fuses at first in its water of crystallisation, and at a higher temperature decomposes, oxygen going off. If the source of heat is removed when it begins to evolve oxygen a yellowish-red mass is obtained which still contains nitric acid. This is heated with glacial acetic acid, when it entirely dissolves. The solution, upon being evaporated to the crystallising point, deposits acetate of uranium, the surplus nitrate of uranium remaining in the mother liquor.

When the acetate separates from a very acid solution by a slight reduction of temperature it forms yellow oblique rhombic prisms, which dissolve in water with slight decomposition and crystallize out on evaporating the solution. They contain two atoms of water of crystallization. When a saturated solution of this salt, at the ordinary temperature, is cooled to a lower degree, square based octohedra separate, which are the same acetate of uranic oxide, but with only one atom of water. If carbonate of ammonia be added to a hot solution of uranic acetate till a precipitate begins to separate, and acetic acid be then added, a solution of a double acetate of uranium and ammonium is formed. Upon allowing this to crystallize it separates in thin yellow silky needles, readily soluble in water and slightly acid to test paper. They are not decomposed by water even when boiling. In a similar manner double acetates can be prepared containing uranium and potash, soda, ammonia, &c. As these are in every respect stable salts it is more than probable that really valuable photographic compounds may be obtained from them.

ON DEVELOPING THE PHOTOGRAPHIC NEGATIVE.*

BY M. AUG. TESTELIN.

WHEN a negative developed with pyrogallie acid is nearly completed, there forms a yellow deposit on the surface, or rather a sort of fatty film so adherent that a stream of water will not detach it. This deposit arises from the decomposi-

* Continued from p. 167.

tion of the pyrogallic acid which absorbs the oxygen of the oxide of the metallic salt: the nitrate of silver is then partially transformed into insoluble ellagic acid, and is consequently deposited proportionally to the development of the image, that is, during the reduction of the nitrate of silver.

Ellagic acid is formed whenever tannic, gallic, or pyrogallic acids are found in contact with the salts of silver, as well as with many other metallic salts in aqueous solution, and it is this body which principally forms the granulous deposits observable during the slow development of paper positives upon albumen and collodion.

We can ascertain the presence of this body upon freshly developed negatives with pyrogallic acid, by pouring upon the surface slightly heated nitric acid, which possesses the property of dissolving ellagic acid with a brilliant red hue which disappears shortly afterwards, because this substance is converted into oxalic acid.

An analogous reaction takes place upon fixing a slightly washed negative obtained in the same manner, with a solution of cyanide of potassium: a violet red hue is obtained, but it disappears almost immediately upon contact of the excess of cyanide. This effect is due probably to the first action produced being that of the potassa (which is always contained in great excess in the cyanide of potassium of commerce), upon the ellagic acid which this alkali dissolves, with the characteristic hue, as forming a salt of potassa insoluble in water, but nevertheless disappearing, in the present instance through the excess of potassa and of cyanide, which also probably modifies this little studied salt.

When the exposure in the camera is terminated, the plate is removed from the frame, in taking it by the upper left hand corner: the collodion surface is kept upwards and the lower corner always a little depressed by inclining the plate.

If the plate does not exceed the ordinary dimensions, 12 by 10, it may be developed while held in the hand; but when several plates must be prepared in succession, the fingers become fatigued, which can easily be avoided by placing the plate on a tripod or other suitable stand. We employ, for example, a large glass funnel, reversed, the pipe of which is enveloped in folds of tissue paper to hold the plate without slipping during the developing operation, or when we are obliged to incline the plate suddenly in various directions. In this manner almost the whole weight of the glass plate may be supported, and staining the fingers is avoided.

Beside, whatever be the means adopted to support the plate, it is placed over a large dish arranged for the purpose upon a high table placed opposite to a window furnished with a pane of yellow glass.

The plate is poised upon the pipe of the reversed funnel in the dish and kept in the position indicated: the side opposite the operator being depressed, and the solution of sulphate of iron is poured on at once.

This operation, apparently so simple, demands, nevertheless, a steady and dexterous hand: there is no particular way of arriving at the perfection of a skilful operator; but in covering at a single dash equally all over a large plate, held in such manner that the liquid is not divided into several channels, really demands much skill. The solution of sulphate of iron, according to the formula already given, must be poured at the moment of development into a glass vessel, the capacity of which is more than sufficient to contain the liquid intended to cover the plate.

The application of the sulphate of iron upon the exposed plate must be made, not by throwing, but by pouring the solution largely and suddenly, commencing at the corner held in the hand, and managing the operation so that the liquid spreads continuously, covering the plate at a single coup, and poured off at the opposite side, held slightly depressed for that purpose. Immediately the developer arrives at the extremity of the plate, the latter is raised so as to cause the liquid to flow back again, and so on con-

tinuously, giving the ferric solution a circular motion, so as to mingle it as intimately as possible with the nitrate of silver on the sensitive film and equalize the action, which, without this precaution would remain partial and occasion a development in the form of streaks or undulating stains arising from the different densities of the two liquids.

In the course of a few seconds the image will appear and gradually become developed; the sensitive film will retain its original aspect in those parts which correspond to the deepest shadows, while the impressed portions become clearly defined; the strongest lights will first appear, then the half tones, and finally the lightest tones and details. At this point the development must be stopped, to prevent the picture becoming fogged, and to retain all its purity. If it has not the desired vigour, as ordinarily happens, it may be strengthened by means of pyrogallic acid.

In this manner very beautiful negatives may be obtained, which give positives on paper very rapidly, and which furnish light proofs, the effect of which is much esteemed.

This phenomenon of the appearance of the picture under the action of the developer is the most interesting in photography; the strangeness, or rather the marvellousness, of this faithful and delicate apparition, by the contact of simple chemical solutions, will always excite the admiration of the attentive observer assisting for the first time at this stage of operations.

The development of the photographic negative is also the most important part of the manipulations, for it is that upon which the beauty of the proof principally depends. The essential thing in application is, that the developing solution poured upon the image covers it at once, and be rapidly and uniformly spread over it without being violently thrown upon it; on the contrary, this would be a very sure cause of failure, because the liquid in becoming divided will form air-bubbles, and be irretrievably lost. We pour the liquid on largely and without hesitation in making it as it were to glide over the glass plate, and flow to the depressed edge, giving such a motion to the liquid as to cause it to act uniformly upon every part of the picture in succession. If we neglect to make the liquid return equally and frequently upon every portion of the plate, there will be unequal intensity in the places avoided, which will be an irreparable defect.

The solution of sulphate of iron in contact with the nitrate of silver which impregnates the sensitive film, reduces the latter salt to the metallic state, and at the same time causes the image to appear; but when the solution becomes thick by this too prompt action, we drive it off the plate by a new coating of the liquid, which must not be encouraged if we desire to obtain pure and well-defined negatives.

It is frequently during this new contact of the sulphate of iron that the last details completely appear, but the picture rarely attains the intensity it ought to possess. To render it more vigorous generally, and in the dark portions especially, we collect in a glass measure the second portion of the sulphate immediately after it has spread all over the plate, and add to it some drops of nitrate of silver of 3 per cent. strength, to which a little acetic acid is added; in pouring the whole upon the plate, we make it cover anew all the parts of the picture successively, which thus acquire intensity. If necessary we repeat the operation, changing each time the thick solution for a fresh quantity of the developer.

Another means, very energetic and much more constant, consists in driving off, as before, the thick layer, arising from the first development, and allowing the greater portion of the excess of sulphate of iron to drain off, and to replace it by a solution composed of

Water	500 parts.
Nitrate of silver, crystallised...	18 "
Acetic acid	20 "
Alcohol... ..	15 "

The mixture is agitated for a few moments by inclining

the plate; then we pour on a third dose of the iron solution and allow the greater portion of it to flow off again, at the same time rapidly mixing the two solutions. The action is very energetic, the negative gains much in vigour, and it must be carefully watched so as to stop it in time.

This method, a little more expensive than the former, is very advantageous for large negatives, we employ it also for plates 12x10 which we can cover sufficiently with from five to seven ounces of the preceding silver solution.

We have in this manner obtained very fine negatives, soft and beautifully modelled, only the lighting must be appropriate, and also present a character of uniformity in the light tones as in the more luminous parts, which must, nevertheless, receive only very little direct light. We must not allow the solutions to remain too long upon the plate after they have begun to thicken, because they deposit particles of metallic silver which impair the purity of the picture.

In most operating-rooms another method, slower in its action, is practised, the superiority of which, however, is undoubted; it consists in first developing the image with sulphate of iron, exactly in the same manner as previously indicated, only we must take care to arrest the action of the developer as soon as the picture appears in all its parts, and before it has begun to fog: it is at this moment, if we clearly understand the process, that we can obtain the wished-for result by modifying the effect, if we perceive that the exposure in the camera has been too long, or not long enough, or the lighting badly distributed, &c. In fact, before going further, let us say that if the exposure, for example, has been exaggerated, it will suffice, to avoid the inconvenience which must necessarily result, to stop the development immediately the shadows are sufficiently brought out, without waiting the action continuing itself, darkening all the details in one uniform grey tint. If the contrary is the case we prolong as much as possible the action of the sulphate of iron to gain on the side of the shadows and light tones. The same thing takes place in an unfavourable lighting of the object; if it be too harsh, we continue the action of the developer a long time, in order to equalise the impression; while if it be uniform and without depth, we endeavour to preserve more opposition or contrast in the picture than it naturally possesses by stopping the reaction sooner than we should do in ordinary cases.

Returning to our own mode of development, let us say, that as we have stopped the coming of the image without any regard to its degree of intensity, we must communicate to it the vigour required for printing positives by means which, no longer developing the image, simply communicate to it more strength in the opaque portions.

To this end, after well washing the plate on both sides, to stop the action of the ferric liquid and remove the last traces of it, we effect the intensifying with pyrogallie acid, mixed with some hundredths of nitrate of silver in aqueous solution. Into a glass measure we put a sufficient quantity of pyrogallie acid prepared according to the formula previously given; then pour the liquid on the plate, in the same manner as with the first developing solution; but accidents being less liable to occur, it is not necessary to pour it on so largely or in so regular a manner. We keep the pyrogallie solution a few seconds upon the picture, and if there be reason to fear that the plate has not been sufficiently freed from the sulphate of iron, we reject the first layer and replace it by a second. In every case, while the solution covers the plate, we put into the glass measure a small quantity of nitrate of silver solution, and collecting the pyrogallie acid that flows off upon inclining the plate, the whole is immediately poured on to it.

We follow the action attentively by viewing the picture as a transparency, by lifting up the plate from time to time, from which we collect in the glass measure the liquid which flows from the lower angle. It is useful to repeat this operation often, by pouring on the pyrogallie acid collected each time in the measure. If this intensifying liquid becomes dark and muddy before the negative is quite finished, the

collodion plate is carefully washed under a stream of pure water, and the action may be continued with a fresh quantity of pyrogallie acid, to which must be added one or two hundredths of nitrate of silver, prepared according to the formula given above.

It is always good to wash the negative with pure water towards the middle of the operation of intensifying, because the pyrogallie acid becomes oxygenated during the reduction, it forms, as we have remarked above, even in contact with the collodion surface, a film, rendered greasy in its aspects by the acids, composed chiefly of insoluble ellagic acid, a film which opposes the contact of the liquid surfaces with that of the negative, which slackens considerably the effect, at the same time these impurities attach themselves more and more to the negative.

The picture should retain all its purity; under the action of the pyrogallie acid it acquires much vigour and relief, but it must not be carried too far. It is not the most vigorous negatives that yield the best proofs. We must, on the contrary, preserve a certain transparency in the darks, for there are shades in those parts as in all the others.

When the negative has arrived at the desired point, it is cautiously washed so as not to remove the collodion film from the glass, its adherence to which is greatly diminished after all these manipulations. If we provide a stream of water from a tap, we must receive the jet that flows upon the middle of the plate, and incline it in different directions to cause it to flow off the edges, so that we incur no risk of raising the collodion by the infiltration of the water at the sides of the plate, where it is always more or less detached.

The undoubted advantage of this process is, that it permits of stopping the development of the picture when it has arrived at a determined point, and in retaining the faculty of augmenting it afterwards to the degree of vigour desired.

The sulphate of iron appears to possess the remarkable property of completely destroying the effect produced by the light upon iodide of silver, as soon as it comes into contact with the latter; either because it destroys it by the reduction of the soluble salts of silver necessary to the sensibility, or from another cause, it acts in such manner, that the pyrogallie acid develops no detail, however weak it may be; be, its operation is limited to strengthening each of the parts already apparent by the metallic molecules which this organic reducing agent slowly liberates, and which fix themselves upon the various tones, in masses more or less considerable according to the extent of the first deposit effected by the sulphate of iron. It thus results that the entire image increases in intensity, or preserves a constant relation between its lights and shades, since the molecular attraction of the silvery particles is effected in the order determined by the luminous image, and the first reaction is exercised by virtue even of these lights and shades.

In treating of the development of collodion negatives, we have not thought of broaching a new subject, but we believe that the complete details of a good method of operating would be found very useful to many photographers. We have no doubt that the method we have here indicated is already more or less known; but when we see how few useful details are published in similar articles, we venture to hope that what we have written will be found of some service.—*Bulletin Belge de la Photographie.*

DRY COLLODION AND DRY PROCESSES.

BY DR. D. VAN MONCKHOVEN.

It is a common error to suppose that dry iodide of silver will not yield pictures in the camera. It is, nevertheless, certain that this substance yields very good results with albumen, waxed paper, and gelatinized paper; but in paper quite exempt from albumen and gelatine, and especially in collodion, iodide of silver sometimes yields pictures, and sometimes not.

We propose in this place to elucidate the cause of this fact.

A sample of recently prepared gun cotton is immersed in alcoholized ether, with which it is left in contact several hours; when it is dissolved, iodide of cadmium is added. We perceive that at first the solution becomes red, and then colourless, and remains so. (It is well understood that the gun cotton gives no acid reaction).

Cover a clean glass with such a collodion, sensitize the film, and carefully wash it with distilled water. Expose it to the light while it is still moist, then cover it with the developing solution mixed with nitrate of silver; a picture will be well developed, but quite fogged, without any intensity, and even when the exposure is prolonged the results are scarcely better.

If, instead of exposing the plate while it is moist, it is not exposed until dry, the same results are observed, but the picture is still more defective.

But if the gun cotton employed, instead of giving an amber-coloured collodion gives one that is bright red, then we observe a reverse state of things. Certainly, by washing with water the excess of nitrate of silver from the film after sensitizing, we remove from it a portion of its sensibility, and still more by leaving it to dry entirely; but the picture obtained is at least not veiled, and acquires great intensity under the influence of the developer.

There exists, then, a cause for the opinion admitted by some that collodion sensitized and simply washed will yield pictures, and also for the contrary opinion.

It is a very remarkable fact that collodions made with decomposed gun cotton, and old collodions, may be used dry without any preservative coating; and also, as a general rule, a good collodion (*i. e.* quick, and yielding not very intense images), cannot be worked dry.

The same thing applies to paper. Make use of a very pure paper, prepared with iodide of potassium and nitrate of silver. Wash it in water and dry it; no image will be obtained, or at least only a very bad proof. But if sized paper be used, then success results.

From this set of facts it results:—

1. That pure iodide of silver is incapable of yielding pictures.

2. That when in presence of an organic substance capable of combining with nitrate of silver, such as albumen, gelatine, resin, &c., it will, on the contrary, yield results when dry.

The proof lies in these two rules:—

A. When the collodion is new, as I have said, it does not ozonize the ether (that is to say, it does not liberate the iodine from the iodides), we shall then have, after sensitizing, a film exempt from organic matters, capable of combining with nitrate of silver, and *the image obtained in the usual manner will be entirely soluble in pure nitric acid.* The same result occurs with paper.

B. But when the gun cotton ozonizes the ether, it is because it contains a foreign organic matter; the same theory results when the collodion is kept a long time. The gun cotton is decomposed into matters hitherto unknown; but it is certain that there is no longer a simple solution of alkaline or metallic iodide, but rather a solution containing also an organic substance, capable of combining with nitrate of silver, and furnishing a picture independently of the iodide of silver.

The proof of this is, that a picture obtained in the ordinary way by the aid of an old collodion, and treated by nitric acid *does not wholly disappear*, the argentic-organic combination on the contrary remains, and *it is so much the more visible the more the collodion is decomposed.*

Moreover, take a good collodion, and employ it dry, with an exaggerated exposure. Then examine the plate, and *no picture will be visible*, just as if iodide of silver prepared in glass vessels had been used. (Washed iodide of silver does not blacken in the light.)

But take an old collodion, employ it dry, and the picture will become visible (at least in the high lights, corresponding with the darkest portions of the negative) on removal from the camera. However, this experiment proves that the

iodide of silver prepared by double decomposition, and well washed, does not blacken. *It is then quite evident that the picture is due rather to the organic matter.*

To operate with dry collodion, therefore, it suffices, according to this theory, to ascertain if the image disappears or not under nitric acid (after development), if traces of collodion remain, it can be employed dry, if not, it cannot.

Such is, in fact, the truth. The following is the method to operate with certainty in dry collodion:—Cover the plate with the collodion to be dried, sensitize the film, expose and develop either with sulphate of iron or pyrogallic acid. Wash in pure water when the picture has come out sufficiently, and cover the plate with pure nitric acid (this acid should remain clear after the addition of nitrate of silver). The picture disappears instantaneously. Remove the acid by immersing the plate for a few moments in water, then carry it into a full light.

Next examine the film attentively, especially in those parts which correspond to the sky or light parts of the model; with good collodions no image at all will be perceptible, but with those which have been made with bad or old gun cotton, or even old collodions, the images will be very perceptible, and the better the more the collodions are decomposed.

Collodions prepared with acid gun cotton do not give rise to this phenomenon, for it is sufficient to add an acid to the collodion; for the best prepared gun cotton decomposes slowly, both when it is dissolved and when it is kept in bottles. The newer it is the more the film is composed of pure iodide of silver, and the more it yields quick pictures; but the older it is the more it ozonizes the ether, the more organic matter it contains capable of combining with nitrate of silver, and the better it is suited for working dry.

To work with dry collodion, then, it suffices to add to the collodion a substance capable of combining with nitrate of silver. This is the purely practical side of the question, which we shall examine in our next article.—*Le Moniteur de la Photographie.*

* MICROPHOTOGRAPHY, OR THE ART OF TAKING ENLARGED COPIES OF PHOTOGRAPHS.*

THIS branch comprehends the mode of taking photographs of microscopic or almost invisible objects, as also of amplification by means of the solar camera. In either case means are resorted to by which light can be concentrated or condensed on the object or collodion positive to be copied and enlarged. These means are combination of plain reflectors, concave reflectors, double convex or plano-convex lenses. The appendages to the solar microscope and the solar camera are fac-similes of each other; but the solar microscope existed before photography had been elicited from chaos; the solar camera, therefore, is a mere imitation of its antecedent; the patentees of the latter instrument, then, can make claim to no originality of design; their only claim can be the application of the instrument to photography.

SOLAR MICROSCOPE.

The appendages to the solar microscope, that is, the condensing part of the apparatus, consists in the first place of a plano mirror in the form of a rectangle, whose width is at least equal to the diameter of the plano-convex or double convex lens which condenses the light received from the mirror. The length of the mirror must be about four times its width. At one end there is a hinge-joint, which allows the mirror to swing on the same like a door. The hinge is fixed to a circle of brass or other metal, which, by means of a dentated periphery, admits of a circular motion. By this contrivance it will be seen that the mirror has two motions at right angles to each other; for instance, supposing the back of the mirror faced the sun at noon, and were perpendicular to the horizon, then one of the motions mentioned would cause the mirror to incline towards the sun until finally it would lie flat on the horizon. The other motion permits the mirror to move either towards the East or the West; so that, as it now stands, if moved towards the West

* From *Humphrey's Journal*.

the silvered surface would face the rising sun; and, if moved in an opposite direction, or towards the East, the silvered surface would face the setting sun. By combining these two motions consentaneously, the mirror can always be so inclined as to reflect the rays of the sun from rising to setting into the axis of the condenser. The two motions in question are effected by means of screws and pinion-wheels, &c.

The part just described might be a concave mirror admitting of the same motions; this would act as a reflector and condenser at the same time. The condenser is fixed in the brass plate which is attached to the window shutter; and around the condenser the metallic ring moves to which the hinge of the mirror is attached. The object of this part of the apparatus is, by refraction, to cause the large bundle of parallel rays, that impinge upon its surface, to be condensed from a cylindrical into a conical form, so that, at a given distance this converging and condensed light will arrive at its apex or focus.

Now at this focus *all the light* that has passed through the lens will be concentrated, and at a variable distance before it arrives at this focus it will cover a variable space, varying from a point or zero upwards to an amount equal to the surface of the lens.

The amount of consideration will be the ratio between the squares of the distances from the focal point; thus suppose the focal distance be twelve inches, and that we intercept the cone of light at three inches from the focus; then by dividing the square of twelve by the square of three we obtain the ratio, which is sixteen, and this indicates that the light at this distance is sixteen times more intense than it was when it first emerged from the lens.

The object of the refracting lens, therefore, is to illumine the object with condensed light. If the lens be achromatic, the light will be white; if not achromatic, it may have spectral colours, of which some are useless in photography, whilst others are exactly those which are needed. Now the scientific optician can arrange his non-achromatic condenser in such a manner as to cover the object with the violet side of the spectrum by which means he draws an advantage from what otherwise would be a disadvantage.

The next appendage to the solar microscope is the *object holder*, which has a sliding motion to or from the condenser in the neighbourhood of the focus by which means the object can be placed in a condensed part of the cone of light which is just sufficient to cover it and no more; a contrivance by which light is economized.

The remaining part of the instrument is the microscope proper, which contains the corrected objectives for magnifying the object.

Now the above description is exactly the same as that of the condensing part of the solar camera. With such an arrangement of mirrors and refractors, the camera and screen may remain fixed during the whole time of the operation.

Another arrangement for concentrating the light is accomplished by means of reflectors fixed in the form of a frustum of a pyramid. But in the application of this contrivance, the camera and screens must all move together on a universal joint like a heliostat, by which means the silver surfaces of the reflectors can always be preserved in front of the sun so as to catch his rays.

The mode of using the solar microscope and the solar camera is in no wise different, excepting that in the former a transparent object is substituted in the holder for the transparent collodion positive in the latter. Each is placed in the cone of condensed light, in order to be brilliantly illumined, and in such a position in reference to the objective or photographic lens, that the rays of the picture coincide after emerging from the front lens with the rays of the cone of light. It is by this means alone that the best enlarged picture can be obtained.

HOW TO FIND THE POINT WHERE THE LENS IS TO BE PLACED.

It appears then that the lens may not be placed in any position for maximum effect; the true position depends upon the power of the condenser. To obtain the best results there ought to be a relative connection between the power of the condenser, the power of the objective, and the position of the object to be magnified. This connection not existing in any of our solar cameras, we must avail ourselves of what is next best, and fix our lens where we can obtain the maximum effect with given

materials. Take out the condenser, therefore, and ascertain the distance of its burning point. Measure this distance in inches and parts of an inch. Next take the front lens (which in this application is the back lens) of the camera tube and measure the distance of its burning point. Subtract one from the other, and the difference will give the distance nearly at which the black lens of the camera tube is to be placed from the condenser. For instance, supposing the focal distance of the condenser be sixteen inches, and of the back lens four inches, fix the latter lens at twelve inches from the condenser. In this way the cone of light from the condenser and the cone from the illumined object will nearly coincide, and will thus produce little or no interference.

Having once found this distance, adjust the tube accordingly and always use the same tube. The size of the diaphragm is not optional. It must be sufficiently large to admit the axis, at least of the peripheral pencils, otherwise those parts cannot appear in the picture; there must, therefore, exist an accurate connection between the size of the object, the correction of the lens, and the opening of the diaphragm; it is possible the combination will work respectably without any stops.

HOW TO TAKE AN ENLARGED NEGATIVE OF A MICROSCOPIC OBJECT.

Fix the solar microscope in the window-shutter of a darkened room. On a platform, constructed for the purpose, place a camera with an elongated bellows attached. The camera can slide between ledges nearer to or farther from the microscope. The axis of the microscope and of the camera coincide. The objectives that are most likely to give satisfaction to beginners are, the one-inch, the half-inch, and the quarter-inch. Insert the object in the holder. Bring the sun's rays, by means of the two screws on the brass plate, into the axis of the microscope. Let an assistant adjust the object into focus by bringing it nearer to the objective or withdrawing it from it, until the image is seen on the ground glass; this sometimes, and especially with a high power, is a very difficult task. When the image is once on the ground glass, let your assistant desist from all further interference excepting that of regulating the mirror, so that the sun shines continually through the object. By means of a microscope adjust the ground glass into accurate focus by sliding the camera. This adjustment is extremely refined; it requires the utmost care—the utmost precision.

When once attained, fix the camera, and see that no light can penetrate the camera excepting through the object glass. Withdraw the ground glass and insert the prepared plate for the negative, and draw out the slide for a short time. You have to find out the time of exposure by experience, so that the first attempt may be a failure. The development and fixing you already know how to manage.

By proceeding in this way the microscopist can prepare negatives of his choice specimens whereby he can obtain prints to aid him in the investigation of nature, much more accurately delineated than can possibly be accomplished by the aid of the camera lucida.

The solar camera is managed in the same way as the solar microscope, by adjustment on the shutter of a darkened room. But in this case no camera box is used. A moveable screen is used instead, on which the prepared paper is stretched on a plane at right angles with the axis of the condenser and the lens. A transparent positive is placed in the holder, in an inverted position, in order that the image on the screen may be direct. The rough adjustment to focus is obtained by moving the screen and the fine adjustment by means of the screw attached to the plateholder. The prepared paper, stretched on a board as if for a water-colour painting, is fixed exactly in the place of the focussing board, and then the cap of the tube is removed. The circle of light is kept in position by the two screws of the camera that move the mirror. The paper may have been prepared either with a chloride, as in the common contact printing process, or with an iodide or bromide, or both, as in the printing process by continuation or development, both of which will be described hereafter. To print by the former process and by means of the solar camera, is a very tedious operation, and will sometimes last several hours before a satisfactory picture can be obtained; by the latter, the process is very short, but the results are not so fine.

I need scarcely remark, what must already have suggested itself to the reader, that the shutter on which the instrument

is fixed has a southern aspect, in order that the photographer can operate from the rising of the sun to the going down of the same. The dark room, too, must be large enough behind the camera to admit a large screen, on which life-size pictures might be projected.

The one-fourth or the one-third tube is an appropriate size for the nine-inch condenser. If the diameter of the posterior lens in the tube were equal to the diameter of the condenser, and of equal focal length, the conditions prescribed above could not be carried out, and the dark room would have to be very large.

It is true that a large lens will produce a magnified picture of any object well illumined without adhering strictly to those conditions; but it is likewise true that the best results are obtained by using the same lens to amplify with which was used to obtain the original negative; and that the diameter of the transparent positive must be considerably less than that of the condenser, in order to obtain the requisite condensation of light upon it, which object could not be obtained if negatives were used that are in relative proportion with large tubes. Besides this, and which is the main point, a short-focussed lens that can perform the work required will perform it more quickly than a long-focussed tube.

A FEW WORDS ON PORTRAITURE.*

THE class of photographic portraits which is chiefly in favour at the present day, known as *carte de visite* or album portraits, make greater demands upon the photographer's knowledge of art principles in regard to composition and arrangement, than any other phase of photography has hitherto done, and this may render more interesting and important any hints which may lead to successful and satisfactory results.

Let it be remembered at the outset, that the mere delineation of an object, the mere production of a likeness, does not constitute a picture. To constitute a good portrait, and produce at the same time a pleasing picture, the model should be represented under such circumstances of position, arrangement, light and shade, and entourage of accessories, as shall indicate character, and at the same time be conducive to pictorial effect. The photographic portraitist labours under the disadvantage, that however perfect his taste, or knowledge of art, he has not absolute control, either over the forms he must delineate, or the relations of light and dark which shall exist in his model. He can, however, control the positions, and the light and shadow, so as to secure the most pleasing and characteristic lines these models possess, and he can by the selection and arrangement of his accessories secure the harmonious disposal of lines and of tones in his pictures; the liberal use of accessories now customary in photographic portraiture, permitting unusual facilities in this direction; but these should be used so as to secure unity and simplicity, harmony and breadth.

One of the first considerations in connection with portraiture, and especially where, as in card pictures, the full length of the figure is shown, will be as to position. This has much to do with the expression of character, as well as pictorial effect. Before speaking of the position of the model, a word or two in regard to the position in the picture, may not be out of place, as this affects the general result more than at first sight may be imagined. The figure should never, or at least very rarely, be exactly in the middle, or equidistant from each side of the picture; nothing is more formal or destructive of pictorial effect than such a position. As a general principle, more space should be in front of the figure than behind, unless some peculiarity of arrangement in the accessories suggest a different disposal. If the figure be placed equidistant from the top and bottom of the picture, it is still more destructive of suggestive truth, and pictorial effect, than if equidistant from the sides. The distant from the top and bottom is the chief means of suggesting the height of the

figure. The nearer the head is to the top of the picture, the taller the figure will appear; and the greater the space overhead, the shorter will be the appearance of the model. Where a series of portraits of a specific size is issued, as in the card portraits now common, a specific proportion might with propriety be adopted. These pictures are, for instance, generally about three inches and a half in length; on such a size a standing figure six feet in height might properly be made three inches high in the picture. If then, the remaining half inch were divided so that the feet of the figure were one-eighth of an inch from the bottom, and the head three-eighths from the top, a fair suggestion of the true proportions would be obtained. In larger portraits, especially busts, the position is not so important, but should still receive attention. A bust in profile, or three quarter face should have more space in front of the head than behind; a bust presenting the direct full face, may, however, without impropriety have the head equidistant from the sides.

The position of the model may be varied without limit; but it should be the aim to secure grace, and character, or both. Not less important than these in producing a satisfactory effect, is the presence of a purpose or object in the position. It is not intended by this to imply that the sitter should be in all cases engaged in some occupation, but care should be taken to avoid the suggestion of either entire vacancy, or the self-consciousness of having a portrait taken. In the portrait of a lady a variety of resources from this may be found; she may be examining a bouquet, arranging a vase of flowers, buttoning a glove, examining a picture, reading a letter, &c., &c. In the portraits of gentlemen, the same occupations would be less suitable; but others are available; even the conventional book held in the hand need not necessarily be arranged in the common-place conventional manner.

Entire repose is by no means inadmissible, but care should be used to secure the absolute feeling and appearance of intelligent repose, avoiding alike effort and vacuity. In all cases straight lines and angles should be avoided as much as possible in arranging the position. The figure perfectly upright, without inclination or curve of any kind is not graceful in any one, and in a lady is especially awkward and undesirable. The figure may lean against a column, a chair, &c., or in a variety of ways a little inclination may be induced, and curved flowing lines secured. In standing, the weight of the body should rest on one foot; this will secure a more perfect sensation of ease and balance than can possibly be obtained when the figure is supported on both feet. Whatever action may be desired in the model should not be secured at the expense of ease; there can be no grace or pictorial effect in the suggestion of an over-strained muscle or dislocated limb.

As regards the question of composition, the greater the simplicity the more perfect will be the result. Elaboration or complexity is undesirable at all times in portraiture, and in photographic portraiture especially so. It is, however, an important point, that a proper balance of lines, and of light and dark be secured. If all the lines in a picture tended in one direction, a most uncomfortable effect would be produced; or if all the objects or masses were accumulated at one side, leaving the other bare and empty, the result would be just as unsatisfactory. All pictures should have at least one principal light, to which all the rest is subordinate. This, in portraiture, is generally the face, upon which the chief interest is supposed to be concentrated. The light may be repeated in varying forms and more subdued degree, so as to carry them throughout the picture, a general principle of chiaroscuro requiring that some light should be carried into the deepest shadows, and *vice versa*. It is desirable, also, that the weight, or heaviest part of the picture, both in colour and form, should be at the base. Thus, the standing figure of a man unsupported by accessories, is very uncomfortable-looking; the picture requires a broader base; this may be secured by the

* From Newman's "Harmonious Colouring," by permission.

arrangement of accessories, or even by the simple resource of a stick or umbrella in his hand, placed at an angle with the body. The best effect is produced when the darkest masses are arranged at the bottom of the picture, as that also tends to the production of equilibrium or balance. Let it be distinctly remembered, however, that these and all other effects in composition must appear natural, and, of course, the artifice must not be seen. The veriest smatterers in art have an impression that the pyramidal form is the most satisfactory in composition; but it requires the skill of an experienced artist to secure the effect without obtruding the means.

Contrast is an important element in pictorial effect; contrast in lines, and contrast in tones. The value of curved lines will be best made apparent by contrasting them with straight lines; relief, vigour, and brilliancy are obtained by due contrast and variety of tones. Contrasts, however, should never be harsh or violent. Masses of black and white brought crudely together, without gradation of any kind, certainly produce contrasts; but without anything of pictorial effect. One of the most important qualities in a picture is *breadth*, of which crude and harsh contrasts are entirely destructive. The immediate juxtaposition of black and white draperies or accessories should, therefore, be as much as possible avoided. Both are necessary in a picture; but they should always be more or less graduated in their approach to each other. For this reason the background of a photograph is generally best of a middle tint, which does not contrast harshly with either dark or light draperies.

An important element in securing the harmonious contrast of tones is the judicious lighting of the model. By all means avoid a direct front light, which is destructive of all relief. Let the light fall on the model at an angle of about 45°; direct vertical light should be carefully avoided; side light may, on the other hand, be freely used. Direct light, it should be remembered, gives force; diffused light, softness. The best results are obtained by judiciously combining the two; direct light to give forms or contours, diffused light to give texture. Too much diffused light leads to flatness and tameness, by weakening the shadows. Some positive light and shadow are necessary to force and vigour.

In the small full-length portraits now fashionable, a variety of accessories and pictorial backgrounds are permissible. In the use of these, one of the most important things is the preservation of *keeping*, by the combination of such pictorial effects in the background, and such accessories only as are harmonious with each other, and with the character of the sitter. Nothing can be more ludicrously incongruous than the combinations sometimes perpetrated; the furniture of a drawing room apparently standing on the sea shore; a lady in evening dress standing amid Swiss mountains; a stolid old gentleman sitting amid vases, balustrades, &c., all wreathed with flowers. Or even when keeping is preserved in these respects, it is not uncommon to see gross violations of all possible perspective; objects in the background lighted from one side, whilst the model is lighted from the opposite direction, &c. It is not necessary, because a column, a curtain, or a chair are really good of their kind, and free from the common-place or vulgar in design and style, that they should appear in every picture; nor because a balustrade is real and well designed, that it should be obtruded in advance of the sitter. Variety is desirable in accessories, both as regards colour and form, so as to be readily able to meet the exigencies of composition. In using painted backgrounds, care should be taken that the light and shadow correspond with that on the model, and it is desirable to avoid designs such as foregrounds of tessellated pavement, which show, in a very definite manner, the exact direction of the perspective lines, and thus suggest one point of light for the landscape, and another for the figure. The carpet, or whatever may be used for the foreground, should be dark in colour, and not of a pattern too strikingly defined.

In grouping for portraiture, the small portraits of which we have been speaking permit the exercise of considerable

discretion, and render the task less difficult than in larger photographic groups. Fewer accessories are necessary for the purposes of composition, the balance of the picture being generally obtained by the arrangement of the figures. Variety may be obtained by the contrast of sitting and standing figures, by full face and profile figures, &c., &c.

These short hints and brief statement of general principles will, it is hoped, be found useful to many photographers.

DIALYSIS.

THE term Dialysis has more than once been used in connection with photographic operations in recent discussions. As it describes a chemical process, possibly not familiar to all our readers, we collate a brief description of its character. Dialysis was the discovery of professor Graham, who noticed that certain substances possess the power of diffusing themselves with great facility through water in comparison with others, and that they could be separated mechanically in solutions by proper appliances. Thus, suppose we take four deep glass vessels, such as long phials, and place in the one a few grains of common salt; in the second an equal quantity of sugar; in the third some gum; in the fourth dried albumen. Let each of the glasses now be filled up cautiously with water, and their contents allowed to stand until they are dissolved by the water. In watching the operations it will be observed that these substances gradually diffuse themselves through the water, but not all in the same period of time. The salt diffuses most quickly, then the sugar in about twice the length of time; the gum takes four times longer, while the albumen takes about twenty times longer. So different is the diffusive power of common salt and albumen in water—though both are soluble—that if the two substances, in equal quantities, are mixed together in water, the salt will completely diffuse itself through the water before the other is dissolved. Those substances which are crystalline are the most diffusive; those least so which resemble gum, glue and albumen. Professor Graham has given the names *crystalloid* and *colloid* to these two classes of substances. The crystalloids also possess the remarkable property of diffusing themselves through solutions of the colloids almost as rapidly as through pure water; while the latter do not possess this property.

A colloid and crystalloid in solution may be separated as follows:—Take a broad hoop, like that of a common wire sieve, and cover its bottom with parchment paper (treated in a peculiar manner with sulphuric acid) and float this vessel on clean water contained in another vessel, then pour into it a solution of common salt and albumen. In a short period afterward, the salt will diffuse itself through the parchment, and leave the colloid or albumen behind. In this way compound crystalloid and colloid solutions may be separated. The parchment vessel is called a dializer, and it has been applied to the examination of the human stomach in a person supposed to have been poisoned by arsenic, which is a crystalloid. The contents of the stomach were placed in a dializer, when the crystalloid passed through into the clean water in the under vessel, while the colloids, constituting the principal part of the food, remained behind. Dialysis may thus be usefully employed in a great number of cases of chemical analysis to facilitate operations.

Flint, which is one of the most insoluble of substances, has been obtained dissolved in pure water by the aid of the dializer. It cannot be dissolved in its natural state, but is first rendered soluble by a chemical process, then boiled in water and afterward separated by the dializer. Thus the flint is first fused with an excess of soda (or potash) which converts it into soluble water glass, or silicate of soda. It is now treated with hydrochloric acid, which unites with the soda and forms common salt. The latter is a crystalloid, the former a colloid. When placed in a dializer the salt solution passes through, while the silica is left behind, and

when it is allowed to stand for some days it assumes the consistency of glycerine and afterward gelatinizes into a solid form. It is stated that a solution of silica thus obtained exerts a peculiar action upon gelatinous tissues, such as skins, and converts them into leather.

No specific application has yet been made of the process of Dialysis to Photography, but it is important to photographers to have at least some slight acquaintance with such general chemical laws.

AERIAL PHOTOGRAPHY.

MR. A. SIMON, writing to the *Telegraph* on this subject, says:—

“Three different motions of the balloon and car concur against the steadiness required for photography, and for many useful philosophical experiments.

“1. The vertical motion, which alone does not alter the respective position of objects, and but very slightly their appearance, although it changes the scale of the photograph.

“2. The horizontal motion, which is sometimes very rapid, and must alter the impression taken.

“3. The rotatory motion of the balloon, combined with a certain independent rotatory motion of the car, which is, I think, the most injurious to the picture.

“These give for result a ‘moved’ or ill-defined picture; for the so-called instantaneous process requires a certain time for exposure, and steadiness of the apparatus is not needed during that time.

“Within certain limits, the vertical motion of the balloon may be checked; not so for the horizontal motion of a balloon carried with a medium moving at a high velocity. The picture must be taken when that speed is at a minimum, which is discernible by referring to some objects on the ground in sight.

“The rotatory swinging to and fro of the car might be obviated by joining each fastening on the ring to two points widely apart—say sixty degrees—on the circumference, where the nettings leave the balloon; or forming a continuous netting, with wide open mesh, down to the ring. The shape assumed, instead of being, as now, that of a cone tangent to the balloon, would be that of an hyperboloid, insuring a much greater stability and obviating some difficulties—such as the entanglement of the ropes; similar means being also taken to connect the car to the ring. The use of gyroscopes will be very advantageous to get a momentary stand-still for the lens.

“In ending, permit me to mention the experiment on aerial photography made in Paris some years ago by Messrs. Nadar and Godard. The balloon was fastened to the ground by means of ropes, notwithstanding which, or perhaps on account of which, instability was the cause of their failure in obtaining satisfactory results. They used to take impressions between two successive oscillations, but that time was not sufficient.

ANNUAL REPORT OF THE SOUTH LONDON PHOTOGRAPHIC SOCIETY.

The Committee of the South London Photographic Society in presenting their Fourth Annual Report, are happy to be able to congratulate the members upon its continued prosperity. The meetings of the Society during the past session have been particularly characterised by their animated and cordial character, and the readiness with which photographic knowledge has been mutually exchanged. The various communications to the Society have been abundantly illustrated by the display of practical results, ingeniously constructed apparatus, and many pure chemicals and compounds. Although your Committee are unable to refer to any very marked or noticeable progress in connection with the art, yet they may notice with satisfaction that the various papers read under its auspices have conveyed the most recent and reliable information upon all subjects of interest. They regret that more zeal and attention have not been evinced in the acquisition of a better understanding of the physics of photography, and would urge upon all possessed of the requisite ability, perseverance in the study of those remarkable phenomena which are presented to observation in daily practice. They desire to express a conviction that a rich harvest of scientific truths is ready to be reaped from an

investigation of the causes of those “anomalous contradictions” which are continually recorded in the photographic literature of the day. They vain would hope that at the conclusion of another session to have equal reason to congratulate their brother members upon advances in scientific and theoretical photography, as they now have in connection with progress in the development of its practical and art capabilities.

Your Committee desire to tender their thanks to the gentlemen who have read communications to the Society and which have embraced papers on—

Subjects.	Names.
“Some Photographie Whimseys” ...	Mr. Leako.
“The Production of Prints on Resinized Paper and Silk,” and “Substitutes for Albumen” ...	„ Cooper.
“Instantaneous Photography” ...	„ Blanchard.
“Photography, its Retrospects and Prospects” ...	„ Fry.
“Rejlander’s Apology for Art Photography” ...	„ Rejlander.
“Thomas Sutton, B. A., on Art Photography” ...	„ Wall.
“Philosophy of Positive Printing” ...	„ Price.
„ “Double Printing” ...	„ Harner.
“Developing and Intensifying” ...	„ Leako.
“Fornic Acid in the Developer” ...	„ Cooper.

They have to congratulate the Society upon having been able to secure for each member copies of three excellent photographs, executed respectively by Messrs. Burn, White, and Rejlander. The ordinary pecuniary value of these, independently of other presentations to members, exceeds the amount of the annual subscriptions.

Since the last report, the South London Photographic Society’s Exhibition at Sydenham, has been brought to a successful termination, and the thanks of the Society are eminently due, and are hereby tendered to the Directors of the Crystal Palace Company, for their liberality in giving to each member free admission to the Palace during its continuance. Thanks are also due to the gentlemen of your own sub-committee who superintended the general arrangements.

Your committee have every reason to believe that the change of the place of meeting has been conducive to the convenience of members, inasmuch as they are assured that the communications with all parts of South London and the College are particularly expeditious and frequent. It has also been the means of enabling many gentlemen of eminence in art and scientific photography to join your ranks, and to take part in the ordinary meetings.

The out-door meetings of the Society have not been satisfactorily attended, and it remains for this meeting to decide as to the propriety of their continuance under official management, or whether they shall be left to private arrangements. The obstacle to their success arises from the necessity of having to appoint fixed days of assembling, and the chances against such occasions being opportune for photographic experiments.

The annual dinner at Dulwich during the vacation afforded every satisfaction, and although entirely apart from the superintendence of your committee, yet is gladly welcomed as a means of fostering the exchange of mutual good feelings, and personal reunion between the members.

It may be as well to state that the finances of your Society are in a satisfactory condition, and that a balance will remain in the hands of the treasurer after the payment of all liabilities. The subscriptions will in future be payable not later than on the second meeting of each session.

Signed on behalf of the Committee,
ALFRED HARMAN, Hon. Sec

Correspondence.

THE SALTS OF SILVER AND THEIR DEPARTMENT WITH ALBUMEN.

SIR,—You having inserted a letter of mine (March 27) on the above subject, I think, with your permission, this is the first place to recall attention to my “Theory and Practical Experiments on the cause of Insolubility on floating (well

prepared) Albumenized Paper on a Solution of Nitrate of Silver, viz., the Liberation of Nitric Acid." I now call attention to Emerson J. Reynolds' article on the same subject, page 251-2, *British Journal*, June 15th 1863, where that gentleman mentions the paper of G. Price, Esq., but does not notice the after discussion, wherein I mentioned my theory. Knowing the value of your space, I only mention the circumstances.—I am, yours, &c. J. W. HART.

Proceedings of Societies.

SOUTH LONDON PHOTOGRAPHIC SOCIETY.

THE annual meeting was held in the City of London College, on the evening of Thursday, June 11, the Rev. F. F. STATHAM, M.A., F.G.S., in the chair.

The minutes of a previous meeting having been read and confirmed, Messrs. W. W. King and W. Brown were elected members of the Society.

Mr. G. WHARTON SIMPSON exhibited a number of very fine specimens of heliographic engraving, by M. De la Blanchere, consisting of the portraits of public men. The exquisite perfection of the pictures as engravings would certainly suggest that the plates owed much to the retouching of the skilled engraver, but he was assured by M. De la Blanchere that these were quite untouched. The pictures were carefully examined and much admired.

Mr. SIMPSON also exhibited, as bearing upon the subject of the evening, a very perfect whole-plate picture, the negative of which was produced by ordinary iron development, without any intensifying with Mr. Blanchard's carte de visite collodion.

Mr. SIMPSON further exhibited Mr. Hughes's interiors of the bridal apartments at Osborne, taken on 10-inch plates with Dallmeyer's No. 1 triple lens, equivalent focus 8 inches. It might be interesting to add that views of the same interiors taken with the globe lens, of which so much had been said, absolutely included less angle than those with the triple. He also exhibited some specimens on enamelled paper, and on amorphous albumenized paper, by the Hon. Nassau Jocelyn.

The annual report of the Committee was then read and adopted (see p. 297). The report of the Treasurer, which showed a balance in favour of the Society, after paying for the three presentation prints of the year, of £8 2s. 2d., was also read and adopted.

Votes of thanks were passed to the officers for the past year and a special vote of thanks to Mr. Cole for the facilities he had kindly afforded the Committee for holding their meetings at his house.

No new nominations having been made, the officers already in existence, with the exception of the Secretary, were re-elected for the coming year.

Mr. HARMAN having retired from the Secretaryship from press of other duties,

Mr. SIMPSON said that he had good reason to hope that at the request of the Society, Mr. Wall, their former Secretary, by whose exertion the Society first came into being, and who had tended it with such assiduity in its infancy, would again accept the office of Secretary. He begged to move that Mr. Wall be again elected Secretary. The motion was seconded and passed by acclamation.

The officers now stand as follows:—

President.—The Rev. F. F. Statham, M.A., F.G.S.

Vice-Presidents.—Sebastian Davis, G. Wharton Simpson, and A. H. Wall.

Hon. Secretary.—A. H. Wall, Sherborne Villa, Dartmouth Park Road, Kentish Town, N. W.

Treasurer.—Noel E. Fitch, 13, Union Street, Borough.

Committee.—Messrs. Howard, Ackland, Blanchard, Harmer, Leake, Foxlee, Martin, and Newcombe.

The subject of open air meetings was then discussed, and it was agreed that open air meetings should be held fortnightly during the coming summer, cards with the dates and places of meeting of which were to be issued by the Secretary. An annual dinner to be held in July was also agreed upon. The particulars to be decided by a Committee and duly announced.

Mr. LEAKE then read a paper on "Developing and Intensifying" (see p. 280), after which

Mr. H. COOPER, Jun., read a short paper on "The Action of Formic Acid in the Developer" (see p. 279). Several negatives, illustrating the points referred to, were handed to the members.

After reading his paper,

Mr. COOPER made a few remarks upon some further experiments; in the course of which he stated that he found the difficulty of intensifying the image obtained by the use of formic acid was increased in proportion as the light was weak, and that the plate may remain for a longer time between sensitizing and developing, without injury, than with the ordinary developer. He also mentioned that the strength of pyro used was 2 grains to the ounce of water, and 15 minims of Morson's formic acid.

Mr. WALL, referring to a remark by Mr. Leake, to the effect that negatives might at times be too brilliant, said that the fact had often struck him forcibly. He had in his album many photographs which would be called by photographers good and brilliant pictures which were, nevertheless, bad likenesses. This he attributed to the photograph being too brilliant. He thought it would probably have struck other professional portraitists that brilliant pictures rarely pleased as likenesses. In some cases, of course, want of brilliancy would impair the likeness. He had recently coloured a solar camera enlargement, which was a soft and somewhat feeble picture. He carefully preserved every tone just as he found it; and having finally a sitting from life before he completed the picture, he was very much astonished to find it entirely unlike. This arose entirely from want of depth and force in the shadows. The face seemed flattened out by the weak shadows. When it was remembered that it was only by the nature and depth of shadows that forms could be indicated the importance of this subject would become very apparent. The shadows could be essentially modified also by the mode of printing, and printing either too deep or too faint might spoil the likeness.

Mr. COOPER had often noticed the fact to which Mr. Wall had referred. He had recently met with a striking illustration of the fact whilst copying a bust of the Princess Alexandra, a copy of which members had seen, and which possessed a very pleasant expression. By strengthening the shadows, however, the effect was entirely changed, and the face absolutely seemed to assume a frown. It was amusing how incapable many of the general public were of appreciating this fact. They seemed to have the impression that photographs must be like, must be true, although there were several good reasons why as likenesses they were often very far from being true.

Mr. SIMPSON thought that professional portraitists generally were very familiar with the fact that the degree of intensity in the picture must be governed by the nature of the subject; and the vigour of the negative, the depth of printing, and even the kind of tone must all be regulated by the character of the original. The delicately round features and tender shadows of a child or beautiful lady would not, for instance, be fairly rendered by a negative having the same force as that required for a strongly marked man's face, neither would it require printing so deeply. If the complexion were blonde it would not require either printing so deep or toning so black as if the complexion were dark. It had often been remarked that the sentiment of a picture largely depended on the printing and toning.

Mr. HOWARD, referring to development, mentioned a circumstance he had met with. He was using an iron developer, and added some citric acid. Thinking he had put too much, he added some ammonia to neutralise it, and to his surprise obtained no image at all.

Mr. DAVIS had met with precisely the same results on adding citrate of ammonia.

Mr. BLANCHARD had tried the same experiment with the same results.

Mr. S. DAVIS, referring to the subject of formic acid, said that at the time when Mr. Claudet announced such a great reduction of exposure as possible when using formic acid, he made some comparative experiments. He was using at the same time an iron developer containing 25 grains of iron and 25 minims of acetic acid. He used a bromo-iodized collodion. He found on testing pyrogallie acid with formic acid, that the latter required an equal or a longer exposure. It might be, however, that with a simply iodized collodion the result would have been different.

Mr. SIMPSON stated that he had recently had an opportunity of seeing Mr. Henry Claudet operate with the developer containing formic acid. He was altogether unprepared for the rapidity he witnessed. With a lens of long focus, a poor light, and almost all the blinds down, one negative was taken in two seconds, and another, with the blinds partially removed, was

only exposed one second. The images flashed out rapidly on applying the developer, and the requisite intensity was very easily obtained. So far as he could judge from the light in the first picture the exposure with ordinary bromo-iodized collodion and iron development would have been 10 seconds, and of the second about 5 seconds. He was altogether astonished at the rapidity. He had not yet had satisfactory opportunity of repeating the experiments. He thought one great source of error in repeating such experiments arose from the natural indisposition to begin *de novo*. Photographers were tempted to use the bath, collodion, &c., they had in hand, merely adding, at random almost, a little formic acid to the developer. If this did not succeed they voted the matter a blunder, and declared the process to be useless as an accelerator. Now Mr. Claudet laid great stress upon exactitude of conditions. The bath, collodion, and developer should all be just as he had described in order to secure success. (See details in our last, p. 277.)

Mr. SMARTT had experimented in the same direction, and with similar results to those which Mr. Simpson had just described. Indeed he could confirm exactly the relative exposures as conjectured by Mr. Simpson. Where ten seconds were required under ordinary circumstances, two were sufficient with pyro and formic acid. To secure successful results it was, however, imperatively necessary to adhere to the exact formula laid down. A bromo-iodized collodion should not be used.

Mr. DAVIS said although he had not succeeded, he thought there was unquestionable evidence of the fact that the exposure was lessened by the use of the developer. The portrait of Dr. Diamond which was exhibited, and which was produced in a very bad light in an incredibly short time, was evidence of that. He had used a bromo-iodized cadmium collodion.

Mr. SIMPSON was not able to speak positively, but he was inclined to the conviction that a potassium iodizer was important in this case. If a potassium iodizer, or a portion of that salt were used, he believed that a bromide might also be used. So far as his present experiments suggested, the bromide in this case gave immunity from spots, &c., without lessening the sensitiveness. He had used a simply iodized collodion, and one containing three grains of a bromide to the ounce, together with a potassium iodizer, and they were about equal in sensitiveness. If bromide of lithium were used, the iodide of potassium might be also used without danger of the double decomposition and formation of bromide of potassium, which generally occurred when bromide of cadmium was used.

Mr. COOPER had used a bromo-iodized collodion containing potassium, and the exposure with it was the same as with simply iodized collodion. With a commercial sample of bromo-iodized collodion the acceleration was not so great. He might mention that whilst a new bath gave the most sensitive results, yet with an old bath containing organic matter, which fogged with iron, pyro and formic acid gave perfectly clean pictures.

Mr. DALLMEYER said it might interest the meeting to know that Mr. Warren de la Rue used the pyro and formic acid developer in his astronomical photographs, and, as he had informed him, found the exposure reduced at least one-half by its aid.

Mr. HOWARD suggested that, as the subject was so important, it should be examined by the Experimental Committee.

After some further conversation, a committee, consisting of Messrs. Davis, Cooper, Leake, Smartt, Blanchard, and Simpson, were requested to examine the subject and open the winter session by a report as to results.

Mr. DALLMEYER then exhibited a camera for taking twelve small pictures on one plate. It was fitted with four portrait lenses of 1 $\frac{1}{4}$ -inch focus and 1 $\frac{1}{4}$ -inch aperture. These were made especially for Mr. Bennett for the production of stereoscopic portraits for a new patent stereoscope. They would also serve for the medallion portraits now produced by some photographers, but the best lens for that purpose was that which he made for Skaife's pistolgraph, which was the most rapid lens in existence, and was especially intended for small portraits.

After especial votes of thanks to the Chairman and retiring Secretary, the proceedings terminated.

Photographic Notes and Queries.

WHAT IS "A LITTLE?"

SIR,—Will you have the goodness to say what, in your opinion, constitutes "a little?"

I am induced to ask this question for the following reasons:

1st. Wishing to rectify a silver bath that had done duty for a long time, I obtained some oxide of silver and nitric acid, "prepared specially" by Mr. _____, of _____,

My instructions were to make the silver solution turbid with the oxide, filter the bath, and add a *little** of the nitric acid solution to every twenty ounces of the bath, with an assurance that it would be at once in a perfectly fit state for use. I followed the instructions—prepared and exposed a plate, which, upon developing, showed evident signs of having been excited in a *strongly alkaline bath*. So, thought I, more acid must be the remedy. I accordingly dropped more into the bath (three drops); tried another plate with a like result; and so I went on adding, drop by drop, until I found that some *thirty-six* drops were only beginning to render the bath in a state for use. Evening closed in upon me without my having been able to get a picture with clear shadows. I may add that the thirty-six drops of acid solution do not give the slightest indication of their presence by the litmus paper test.

Did I add too much oxide? there was considerable deposit on the filtering paper. I believe that Mr. _____'s nitric acid solution contains an infinitesimal quantity of the acid, and that it is inefficient for the purpose stated.

Am I right? or any other man, to pay two shillings for—having failed?

Add "a little"—

I have just opened Sutton's *Notes* of the 15th instant. On page 140, 2nd column, line 14 from top, he says, in reference to the acidification of a bath of thirty-five grains (which is the strength of mine), "add 'a little' acetic acid to it, say six drops to the ounce of solution."

Is he right, or —? to add 3 $\frac{1}{2}$ drachms of acetic acid to a bath of 35 ounces, and to call it "a little?"

In conclusion, will you kindly answer the following questions: 1st. In rectifying a bath can it be rendered too alkaline, thus necessitating a large addition of nitric acid to make it fit for use, or is an excess of oxide immaterial?

2nd. What amount of *acetic acid* should be added to a neutral silver bath to put it in good working order for "Hilshop's" dry process?

3rd. Should a bath acidified with either nitric or acetic acid give unmistakable evidence of its presence by the litmus paper test?

Apologizing for thus troubling you, I am, Sir, your obliged servant,

No. 1 to No. 249.

London, June 16th, 1863.

[The term "little" must always be understood in a relative sense, as it has no absolute and independent definition. Where it is used in giving formulae, it generally implies that the exact quantity is unimportant or undetermined, and that a certain discretion is permissible. The acid to which you refer is, we believe, made very dilute, in order that the addition may be easily graduated. In using dilute solutions, time is always necessary, in order to complete the necessary reactions between the agents employed; and with the acids in question it is probable that a result would be produced in a few hours not apparent in a few minutes. We should scarcely call six drops of acetic acid to an ounce of silver solution "little," but it may be regarded as little when compared with the thirty drops added to the aceto-nitrate bath used for Taupenot plates. In reference to your questions,

1st. Oxide of silver is very sparingly soluble in water or in the nitrate bath, only just sufficiently so to produce a very slightly-alkaline reaction. Under ordinary circumstances, therefore, the only result of adding too much oxide of silver is a certain amount of waste of silver, all excess being filtered out. A very slight trace of nitric acid is then sufficient to correct the alkalinity. But if a collodion containing salts of ammonium have been used largely in the bath, it will contain nitrate of ammonia, in a solution of which oxide of silver is soluble, and a sufficient amount might be dissolved to require a very much larger amount of nitric acid to neutralise it than you used. Although, under ordinary circumstances, the mode to which you refer is the most philosophical mode of rectifying a bath, and is generally successful, yet, for the reason to which we have referred, it is often desirable to use carbonate of soda instead.

2nd. We should say two or three drops to each ounce. If any trace of fog were present, we should add the acid until the fog disappear.

* Five minims the stated quantity.

3rd. If the litmus paper be properly prepared, it will show traces of any appreciable acidity, with either nitric or acetic acid; but we always prefer trying a plate to trying litmus paper. The exact amount of change in litmus paper is not a certain guide: trying a plate is.—*Ed.*]

Talk in the Studio.

THE ROYAL SOCIETY.—We have pleasure in announcing that Mr. William Crookes, whose name is well known to the readers of this journal, was recently elected a member of the Royal Society; an honour the more valuable because of the large number of candidates and the small number of those elected.

PLATE-CLEANING PREPARATION.—We have been for some time past using Werge's Plate-cleaning Solution, received from Mr. Hughes, of Oxford Street. It is the most efficient article we have used for the purpose indicated. The instructions on the label direct that the plate should be washed first and then finished with a little of the solution on a tuft of cotton wool. We have, however, used it without any prior preparation of the plate, whether new or old, old and dried films being removed by it with surprising ease, and a chemically clean surface obtained at once. We can strongly recommend it.

We have also tried for the same purpose a preparation in powder, to be used dry. It is entitled "Photographic Polish," and is prepared by Sanderson Brothers, of Eccleshall. It is applied with a piece of cotton cloth to the glass, without water or other vehicle. The plate must, of course, be freed from old films, &c., first. This powder then gives a good polish.

DOUBLE SULPHATE DEVELOPER.—Messrs. Beckett and Willis, of Scarborough, write:—"We enclose you a few more specimens of prints from negatives developed with the double sulphate of iron process as given in our letter about a fortnight ago, which appeared in your paper. We have received several letters since it was published, complaining that the persons that had tried it could not produce the same results. Two or three others wrote to us to thank us for the information, saying that they could produce beautiful pictures with it without any after strengthening with pyro and silver. This is a proof that those that did not succeed could not have used chemicals in proper condition as we have not the least trouble to produce good results in every case with less than half the exposure required for the old process with the ordinary sulphate of iron. You will be able to judge from the prints the class of negative they have been taken from. As a further proof of what we state we will send you one of the negatives to look at and you will then see the kind of negative it produces. These prints are toned with the same formulae that we gave in our last letter, chloride of lime and gold. Almost any tone can be produced with this bath: we have toned these few prints different colours to show what can be done with it on the new enamel paper; it may be as well to say that this paper was bought of Harvey, Reynolds, and Fowler, of Leeds, but we have several samples from other places that are equally as good as this." [The negative received is very fine indeed, at once soft and brilliant, and the prints delicate, vigorous, and of fine tone.—*Ed.*]

To Correspondents.

L. L. H.—The orange-flashed glass is coloured with silver and will resist actinic rays well. The brown pot metal may be used in a dull light, but not if full sunshine fall upon it. We do not know of any elastic dressing for woven fabrics, except solution of india-rubber or a varnish of boiled oil. Nitric acid has generally been regarded as injurious in a developer for negatives; but we are not sure that it is with good ground. In some recent experiments we found it gave great brilliancy, without injuring the intensity of the image. Good prints from your negatives are worth exhibiting.

ALPHA.—The lime bath is most favourable to the production of black tones. Use an intense negative, print deep, and tone until a little more than the desired depth of tone is required. By adopting this method you should have no difficulty in obtaining black tones.

CALX.—You are scarcely sufficiently clear as to the appearance of the stains of which you complain. Do they consist of dead white reductions of metallic silver? From your description it appears very probable that it arises from some kind of floating matter, or scum, on the surface of the silver solution. We have occasionally known stains arise from the use of a dipper which held a portion of the solution in its curve. To avoid such an annoyance, we prefer to use a dipper with a shoulder, instead of a curve; or if it have a curve, as many of gutta-percha or ebonite have, we pierce the bottom with one or two holes, so as to prevent it holding any of the solution. We see no reason to suppose that the fault is in your collodion.

AN OLD AMATEUR.—The stains in your prints are the result of partially imperfect fixation, arising most probably from the prints sticking together in the hypo bath, which was probably weak or old.

TYNESIDE.—You do not seem quite to understand the description referred to. The copying box described takes a plate 12 by 10; it is three inches deep from front to back, that is, there are three inches depth of wood in the frame. In the front end the negative is placed, and to the other end the flexible body is attached. When working this flexible body is attached to the lens. 2. The negatives are laid into the rabbit of the frame intended to hold them, and kept in position by a small hasp or turn button, which presses on the edge. A base-board of about three feet long will answer your purpose probably. That is if you use your quarter-plate lens, probably of about 6 inches focus, for the enlarging. If the box which holds the negative have a capability of extending to about 9 inches, and the camera to about 18 inches, that will enable you to enlarge two diameters. We do not remember the price of the box to which you refer. 2. If you added 10 grains of citric acid to 5 grains of sulphate of iron in an ounce of water, silver may be added freely without fear of decomposition. We have placed such a solution with silver added in sunlight for five minutes without any decomposition. 3. You obtain very clean pictures by washing and redipping. Clean pictures ought to be obtained without that trouble; but did you obtain any increase of sensitiveness?

T. H. REDIN.—The metallic spots on the paper, to which you refer, are a very serious annoyance; but we regret that we do not know of any means of avoiding them, nor of any paper which possesses certain freedom from them.

PIETROS.—One of the greatest difficulties in the way of giving exact formulae with chloride of lime, consists in the fact that it is a very uncertain compound, the amount of chlorine varying in different samples, and indeed continually becoming less with exposure in the same sample. There is no especial quality prepared for toning purposes, nor do we know of any advantage which would be gained if there were. Your prints exhibit a virulent form of meanness, most probably due to excess of chloride of lime. You should have used hot water in making the solution. In using the gold and carbonate of soda hot, coldness is the result of overtoning, and meanness the result of its over rapid action.

E. L., CHESTER.—We have never found that the prints toned by the lime bath reddened more in the hypo than those toned by other baths; but we have noticed that those toned in the lime bath, which look red when wet, often become very black on drying.

TYRO.—It is desirable, if possible, to have light from both sides in the glass room, but is possible, nevertheless, to obtain very good pictures in a studio lighted from one side only. The general design of your room appears good; you do not state the extent of glass you intend to have, but, judging from your sketch, we should think it desirable to have a little more, and nearly twice the amount of space overhead opaque.

K.—The prices of books, and other articles, are generally stated in advertisements, not in literary notices. The price of each number of "Adjutor," containing five photographs, is fifteen shillings.

J. SMITH.—Lamp-black and whiting, mixed with size or thin glue, in suitable proportion, will give a very good dark distemper background.

F. M. C.—Bromide and iodide of lithium are somewhat expensive salts at present. A few years ago we paid a guinea an ounce for some. They can now be purchased at about 8s. or 10s. an ounce. Possibly they may become cheaper if the demand increase. 2. Bromide of cadmium is of somewhat variable constitution, some samples containing more water of crystallization than others, and many samples containing a good deal of water mechanically combined. 3. Bromide of potassium is much more sparingly soluble in alcohol than iodide of the same base. 4. It is always desirable to allow collodion to stand for a day or two after iodizing, before use.

G. J.—Your cards look rough and coarse as you state, but it is chiefly from want of rolling. Get a rolling-press: there are several good and cheap ones in the market. The large ones of Bury, Brothers, are capital. One of the most efficient small ones we have seen is that of Mr. Jabez Hughes; it gives a surface almost rivaling that of enamel paper.

JARRETT.—The sentence in the work you quote, stating rapidity of action in lenses to be a matter of chance, is simply nonsense. The primary source of rapidity depends, other things being equal, upon the relation of aperture to focus; the larger the aperture and the shorter the focus, the more rapid will be the action of the lens. As a general rule, the largest aperture with which single landscape lenses can be worked is one-twelfth of the focal length, and a much better result can be obtained with an aperture half the size. Ordinary portrait lenses are generally made with their full aperture one-fourth or one-fifth of the equivalent focal length. Quick-acting portrait lenses have their full aperture about one-third of the focal length. In the lens used in Skiffie's pistol camera the full aperture is nearly equal to the focal length, and hence its great rapidity.

TROUBLE.—The negative collodion of the maker you name is, we believe, simply iodized. The spots and streaks of which you complain will probably disappear on adding a little of a bromide; say half a grain to each ounce of collodion.

R. P.—You had better adhere to the method you have found successful. The prints are very good.

S. T.—We cannot undertake commissions to select lenses. Our time is fully occupied with our own absolute duties.

AN OLD SUBSCRIBER.—We have not heard that a photographer has been sent out to Chili and Peru for the purpose of taking a series of photographs for the British Government. Several correspondents in our next.

Photographs Registered during the Past Week.

MR. SAMUEL WALTERS, 3, Falkner Crescent, Bootle, near Liverpool,
Photograph of the Royal Mail Steam Ship, *Scotia*.

Photograph of the Confederate Steam Ship, *Florida*.

MR. CHARLES MILLINGTON DRAYSON, 13, St. George's Street, Canterbury,
Two Photographs of the late Dr. Russell, Canon of Canterbury.

MR. JAMES HALSTED BOND, 42, Darlington Street, Wolverhampton,
"Portrait."

MR. JOHN MARCHBANK, Belgrave Place, Bradford,
Photograph of M. W. Thompson, Esq., Mayor of Bradford.

** The Publisher respectfully requests that all remittances above 3s. may be made by Post-Office Orders, payable to THOMAS PIPER, at the Chief Office, St. Martin's-le-Grand. Sums below 3s. may be remitted in postage stamps.

THE PHOTOGRAPHIC NEWS.



VOL. VII. No. 251.—June 26, 1863.

CONTENTS.

	PAGE		PAGE
Formic Acid in the Developer.....	301	Scientific Photography. By M. Ernest Lacan	308
Dr. Kemp's Description of Certain Dry Processes	302	About Collodion, &c. By J. Milton Sanders, LL.D.	308
Critical Notices	303	Impurities in Alcohol	309
A Neat Mode of Washing Sensitive Plates	304	The Stereograph and the Stereoscope	310
Scientific Gossip	304	Correspondence—Photography in New York, &c.	310
The Iron Printing Process	305	Photographic Notes and Queries	311
Art in Photography. By M. Blanquet Eyraud.....	306	To Correspondents.....	312
Preparations Employed in the Collodion Process for Positives. By Charles Waldack	307	Photographs Registered during the past Week	312

FORMIC ACID IN THE DEVELOPER.

MR. MAXWELL LYTE calls our attention to the fact that we have, unintentionally, done him some injustice in the ignoring his claim to priority in the use of formic acid in the developer. We recently referred its first use to the Rev. J. Lawson Sisson, whose communication on the subject was published in the journal of the Photographic Society, in December, 1853. It was from seeing Mr. Sisson's communication that we first used formic acid ourselves, and we were under the impression that his was the first publication. We find, however, that three months prior to Mr. Sisson's communication Mr. M. Lyte had pointed out the advantages possessed by this acid in the developer. In the *Notes and Queries* of September 10th, 1853, a communication from Mr. Lyte appeared, from which the following is an extract:—

My developing agent is made as follows:—Take
 Distilled water 10 ounces
 Pyrogallic acid 6 grains
 Formic acid 1 ounce

The latter is not to be the concentrated acid but merely the commercial strength. These when mixed form so powerful a developing agent that the picture is brought out in its full intensity almost instantly, while at the same time all the deep shades are quite unaffected and the half-tones come out with a brilliancy I have never seen before.

Another excellent developing agent is composed as follows:—Take

Distilled water 10 ounces
 Sulphuric acid 3 drops
 Protosulphate of iron ½ ounce
 Formic acid 1 "

The formic acid is also a most capital addition to the proto-nitrate of iron, and either this or the former liquid produce most brilliant positives, leaving a fine coating of dead white silver.

A similar communication, dated August 19th, appeared in the *Photographic Journal* published on September the 21st, 1863.

We have much pleasure in making this rectification, the more so, that, whilst many valuable contributions to the progress of our art have been made by Mr. Lyte, this is not the first time his claims to priority in processes to which he has given origin have been unfairly overlooked. So far as the use of formic acid is concerned, we are glad to be able to rectify the matter at once.

Writing at the present time on the subject Mr. Lyte adds:—

The only reason which induced me to abandon the use of formic acid possessing as it does most manifest advantages, especially as a developer in *dry processes* or where light is deficient, was the variable strength and impurity of the commercial product of that day, and indeed the difficulty of obtaining it at all. Then pure acid being then only known as a curiosity in the laboratory. Now, however, with the improved methods of manufacture, I have no hesitation in recommending its use as being decidedly advantageous and it is even possible that if

made on a large scale, it might be found cheaper than acetic as well as being superior to it in other respects.

We fear that the difficulty to which Mr. Lyte refers is still largely in existence. Formic acid is, unfortunately, as sold commercially at the present time, a very uncertain and indefinite preparation, in many instances abounding with impurities, and, when pure, of uncertain strength. One eminent manufacturing chemist with whom we had some conversation on the subject, expressed a conviction that it was to the presence of some of the impurities generally present that much of its value as an accelerator was due, and that pure formic acid would be very similar in its action, when added to the developer, to sulphuric acid applied in the same way. Another chemist who has been experimenting in this direction, expresses his conviction that it is to the pure acid the advantage must be attributed. A sample, stated to be quite pure, gave, in Mr. Claudet's hands, excellent results, when used in much less proportion than he commonly employed.

But the term pure is unsatisfactory, unless we have at the same time some information as to the true proportion of acid contained. With a pure sample of acid of a definite strength, it would be merely a question of careful experiment, pursuing the exhaustive process, to establish a definite formula, which might be relied upon as uniform in its action.

The *rationale* of the alleged action is plausible. Formic acid is, in itself, at once a reducing agent and an acid retarding reduction. This anomalous combination of qualities is thus explained. On those portions of the plate upon which the light has acted it aids reduction; whilst on the shadows, upon which light has not acted, it exerts its acid action, retarding the reduction of the free silver, and preserving them perfectly clean. This latter is a quality especially apparent, the perfect cleanliness of the shadows, even when the development is considerably pushed. That it is an accelerator, when the proper conditions are secured, there can be little doubt. We have not yet had opportunity of preparing everything *de novo* for a series of satisfactory comparative experiments; but such additional experiments as we have been able to make have been unquestionably in its favour. The exposure in our hands continues to be about the same as for iron development, but yielding an especially clean, brilliant, and delicate negative with fine half-tone, dense lights, and in the deepest shadows no more deposit than bare glass. The colour of the negatives by reflected light is unusual, the image showing as a positive having lights of a bluish or steely grey. The collodion which has given us best results, contains about equal parts of the iodides of cadmium and potassium and bromide of lithium. With simply iodized collodion the time of exposure is about the same, but the negative is not so clean, occasional small spots and comets being apparent. With some other samples of bromo-iodized collodion, the exposure is similar, but the image is thinner than with iron. We tried it with one sample of collodion

which we should have expected to be useless. It was a sample, prepared by Mr. Sutton at King's College about two years ago, simply iodized with iodide of sodium. The bottle was about half full and had become quite red. The ether having nearly all evaporated, we added about an equal bulk of simply iodized cadmium collodion to thin it. This mixture gave us, with formic acid, equally rapid results as with a comparatively new collodion. We believe that the subject is one which will repay careful experiment.

DR. KEMP'S DESCRIPTION OF CERTAIN DRY PROCESSES.*

The true theory of the dry collodion processes, remains but very little understood. We are in the dark as to the precise channel into which effort for a perfect dry process should be directed. We are in the dark as to the exact cause of success in many of the processes which are found in practice more or less satisfactory. We are uncertain whether the action of the various preservatives in use is chemical or simply mechanical. "If we can but determine laws," Dr. Kemp observes, "the knowledge of the extent of their operation and the phenomena arising therefrom, becomes a mere question of *time and work*." But in the matter before us, the great difficulty is to determine laws. We have a large number of facts upon which to generalize, but they are not sufficiently specific in their bearing to lead to certain conclusions. Some excellent authorities have maintained that the presence of an organic salt of silver was necessary to success, and have therefore referred the value of the various preservatives applied, to this power to supply the necessary organic element. On the other hand, Dr. Hill Norris, unquestionably one of the ablest authorities on the subject, entirely ignores this theory, and states the value of the various preservative agents to depend upon their power to maintain certain mechanical or structural conditions of the film. Almost all the known facts on the subject may be used to confirm either theory. Again, rapidity in dry plates has been held by some to depend upon the preservation in the film of a certain portion of free nitrate of silver. Dr. Hill Norris on the other hand states that he has been able to eliminate from his extra sensitive plates every trace of free nitrate, without in any degree impairing their sensitiveness.

Dr. Kemp does not undertake in this pamphlet to enter into the theoretical department of the research to which it is devoted. His work is rather a record of experiments with certain practical deductions therefrom. He remarks, however, in his preface that the *rationale* of the dry processes will, he believes, be deprived of much obscurity by recognizing certain principles which he lays down. We will quote and leave them to the judgment of our readers:—

Two classes of sensitive surfaces exist, to one or other of which we may refer all the processes which come under the domain of photography.

1. We have a surface so prepared that, having been exposed to the influence of light, the iodide of silver remains in a quiescent state, until stimulated into action by a developer; to this class belong the usual wet collodion and most of the dry processes.

2. In addition to such a surface, we introduce a substance which not only places the iodide of silver in a condition to be acted upon by a developer, but initiates the action during the exposure of the surface to light. The Talbotype paper and dry tannin processes of Major Russell are instances of this latter class; and the methods proposed in the following chapters will illustrate both of these divisions.

We glean from Dr. Kemp's pamphlet that he is an ardent experimentalist, and in this little work his object is rather to make known certain modifications of existing processes, which have given him good results, and to suggest his view of the causes, than to propose anything essentially new. He describes four processes, each of which have their especial advantages and degrees of sensitiveness.

The first process is the malt process, with some slight

modifications in detail. Plates prepared by this process, he finds, require an exposure, varying with the nature of the subject and state of light, of from a minute and a half to two minutes, with a stereoscopic single lens with quarter inch stop.

The second process consists in the use of a mixture of tannin and malt. The exposure for plates by this process, under the same conditions, he estimates at one minute.

We may remark upon this by the way that the author states he was not aware that any one else had tried such a mixture until he saw an allusion to its use by Mr. Fassett at a recent meeting of the Philadelphia Photographic Society. Its use had, however, been described nearly two years anterior to the allusion in question. In July, 1861, we received from Mr. Penny, of Cheltenham, a couple of very fine photographs, the negatives of which were produced upon plates prepared with tannin and malt, the details of which were published in our pages at the time. Since that time, we believe, Mr. Penny has used the process with great success.

The third process consists in the use of a mixture of tannin and glycerine. The exposure under the same conditions as the others is estimated at from thirty to forty seconds.

The fourth process consists in the use of tannin, glycerine, nitrate of silver, and formic acid. The time of exposure has not yet been satisfactorily determined, but it is estimated at from fifteen to twenty seconds.

In regard to the first—the malt process—the author states that on its first announcement he was predisposed in its favour, for the following considerations:—

All the substances which play an important part in the production of the photographic image are either aggregate forms, the molecules of which are held together by very slight chemical affinity, or they are the derivatives of such; and it would be difficult to name a substance in which these two properties are more remarkably united than in the case of malt. We are acquainted, for instance, with a variety of substances, differing widely in their appearance as to physical characters, but all comprised between the limits of the formula, C₁₂ H₁₉ O₉, and C₁₂ H₁₄ O₁₄ differing, in fact in elementary composition only as the quantity of the elements of water which they contain; thus, dextrine, or British gum, C₁₂ H₁₀ O₁₀, only differs from starch C₁₂ H₁₉ O₉, in containing the elements of one equivalent of water; cane sugar C₁₂ H₁₁ O₁₁, in containing the elements of two equivalents of water; crystallised sugar of milk, C₁₂ H₁₂ O₁₂, in containing the elements of three equivalents of water; and so on to the sugar of fruits, C₁₂ H₁₄ O₁₄, which contains the elements of five equivalents of water.

Now malt contains, not only the radix of this series—*starch*—which is capable of being thus transformed, but it contains, in rich abundance, this radix actually transformed into some of the substances above alluded to, but pre-eminently disposed to still further disintegration, from the very circumstance of its containing within itself the catalytic body which, above all others, effects these changes with infinite rapidity, and, for that reason, called *diastase*, with such energy, moreover, that a single part of this substance is capable of converting 2000 parts of starch, first into dextrine, eventually into grape sugar. Certain conditions, indeed, are necessary, and these are generally supposed to be very simple, but are, in fact, mightily effective engines in all organic changes—*heat and moisture*. Nor will it escape observation that two of the substances above mentioned, gum and grape sugar, are familiar to us as agents employed from the earliest days of photography, grape sugar especially, as what was supposed to be an accelerator, and, at one time, much recommended in the wax paper process—an accelerator certainly in one sense, as the writer can testify, for it has a marvellous tendency, in slow development, to produce excessive action in the developer and to cause the silver to be deposited, not only on the points acted upon by light, but over the whole surface, thus destroying the purity of the whites and damaging, if not spoiling, the negative. Again, collodion itself is the derivative of a body, *cotton*, closely analogous in its chemical composition to starch, and coming within the series of compounds to which we have alluded: analogy, then, was not urged beyond its legitimate bounds in suggesting that the powerful catalytic body, *diastase*, might, even in collodion itself, effect a change highly conducive to initiating or accelerating changes in the iodide of silver under the influence of light.

The process, as described by its propounder (Mr. Maenair), did not, however, yield in Dr. Kemp's hands satisfactory negatives—they were thin and deficient in vigour. Still impressed with the theoretical considerations in its favour, which we have quoted, he proceeded to further experiments, and at length arrived at satisfactory results. We subjoin the details of what he distinguishes as the

First Process.

Take two ounces of malt, crushed in a mill, and break it up still further by passing over it several times an ordinary roller, such as is used for making pastry; pale malt should be preferred, because in high-dried malt much of the starch is converted into British gum, and a very viscid infusion is produced, not adapted to the purpose contemplated. Place the malt, thus bruised, in an earthenware jug, or any other suitable vessel, and pour on it, by degrees, two fluid ounces of lukewarm water, with constant stirring, and

* A Description of Certain Dry Processes in Photography, especially adapted to the use of the Tourist, with Supplementary Notice of Plans useful to the Scientific Traveller and Misjourner. By George Kemp, M.D., St. Peter's College, Cambridge. London: J. W. Davies.

let the whole be kept in a warm, but not hot, place for a quarter of an hour, a cool kitchen oven answers the purpose well; in the meantime raise eight ounces of distilled, or, at any rate, pure rain water to the boiling point, and pour it on the malt, soaked as above, constantly stirring; cover the vessel and return it to a warm situation, and thus it may be left for two hours, by which time the fluid will have entirely changed its character and become sweet; it may now be allowed to cool for an hour, and then the whole contents of the vessel should be emptied on a canvas or hair strainer, a common sieve in fact, and, when the fluid has run through, a couple of ounces more distilled water should be quietly poured on the pasty mass, and thus the infusion which it retains will be principally removed by displacement. It is very important to pay attention to the quality of the water, and negligence in this respect has in more than one instance led to the rejection of this process; of course, if chlorides or carbonates be contained in the water, which is almost invariably the case with ordinary hard water, the plates, when treated with the preservative fluid, will necessarily be rendered insensitive from the formation of chlorides or carbonate of silver, in the original plan; and the subsequent preparation, however, of the preservative fluid, by the writer's method, will prevent the possibility of the latter salt being formed. On resting for a short time, the strained fluid will have deposited a thick sediment, from which the clear supernatant fluid should be poured; it is not necessary to filter it, which is a very tedious process, and with the quantities above proposed, fluid enough may be poured off to coat three dozen stereoscopic plates. Pour the fluid, thus obtained, into a Florence flask, or such vessel, add ten drops of glacial acetic acid, agitate, place the flask in a water bath and raise to the boiling point, retaining it at this temperature until the fluid in the vessel boils well, it may then be allowed to cool. As it cools, we shall again find a fluid sediment, which, as above, may be separated by decantation; add half an ounce of alcohol and the preservative fluid is prepared, requiring, however, in most cases to be strained, though it is useless to filter it, as, even when passed through a filter, it will retain its milky, emulsive appearance, which is no detriment and cannot be removed, excepting by a circuitous, complicated process, and we all know that it is essential in photographic operations to keep the conditions as simple as possible. The subsequent steps are those common to all prepared plates, that is to say, the film of collodion is sensitized in the nitrate of silver bath, and thoroughly washed with distilled, or, at any rate, pure rain water; the preservative fluid is then poured upon it repeatedly and in such a manner as to ensure its action upon every portion of the surface, and then, deviating from the directions of Mr. Macnair, the plate is introduced into a dish of soft water and allowed to soak for five or ten minutes; it is again washed with a fresh supply of water and placed in a suitable position to drain, resting one corner on blotting-paper. In the course of half an hour it may be exposed to heat in any suitable manner in order that it might become thoroughly dry; the plate, in fact, should be heated to such a degree as the hand will just bear, and may then be stowed away for use.

Plates prepared by this process, and rigidly secluded from light, damp, and foul air, are stated to keep for at least six weeks.

One of the especial characteristics of the malt process was observed to be the tenacity with which it adhered to the glass, and it occurred to the author to utilise this quality in the tannin process in which the greatest trouble is the tendency of the film to leave the glass. After a variety of experiments, which are detailed, the following was determined upon as the

Second Process.

- "1. Having prepared malt infusion and strained it, add one-third bulk of alcohol. Leave to deposit, and filter.
- "2. Just before using, add an equal bulk of solution of tannin in water, five grains to the ounce, and again filter."

This solution was used in the usual way, and from the extracts which the author gives from his note-book, we learn that plates kept two months give good results. We may here note in the author's experiments a somewhat unusual one, which is however stated to be successful, a tannin plate is re-dipped in an aceto-nitrate of silver bath before developing.

The author was anxious, however, to obtain a greater degree of sensitiveness without any sacrifice of other good qualities, and bearing in mind the theoretical considerations which had predisposed him in favour of malt, he looked for another body "not only produced from others by changes easily effected, but in itself so nicely balanced as to the forces which keep its molecules in a state of aggregation, that these can be disturbed and assume new forms by apparently trifling causes." Such a substance he found in glycerine, and by its aid, after various experiments, he was led to the

Third Process.

"The preservative solution for the tanno-glycerine process is thus prepared:—

Solution A.	Tannic acid	30 grains
	Water	1 ounce
	Glacial acetic acid	5 drops.
Solution B.	Glycerine	1 drachm
	Solution A	2 drachms
	Water	5 "

which latter is poured on and off the plate in the usual manner adopted at

this stage." The addition of acetic acid was made in consequence of slight fogginess observed on certain portions of the plate during development, and it certainly remedied the evil; but the bath was in fault, as it gave foggy results with the wet process.

The author refers to this process as giving very good results for interiors, and gives an extract from his note-book to the effect that the two halves of a stereoscopic plate had respectively ten seconds and twenty seconds exposure in his drawing-room with a Dallmeyer's stereoscopic lens, No. 4 stop, on a dull day in December; both halves coming out with long development.

The next process is stated to promise very rapid results, but requires great care in its management. It is called

Fourth Process.

The tannin and glycerine are used as before, with the addition of ten minims of formic acid to each ounce of the preservative solution, and when well mixed, which, of course, must be at the time of using, ten minims of solution of nitrate of silver, strength twenty grains to the ounce; the quantity of the two last fluids may be increased to thirty minims of each; but most extraordinary care must be taken thoroughly to wash the plates. Let it also be observed that formic acid of the strength used by the writer, which is the strongest and purest he can obtain, has a great tendency to loosen the film bodily from the plate.

Plates by this process have not been kept more than a day.

With regard to the collodion to be used with these processes, Dr. Kemp expresses a conviction that any good bromo-iodized collodion will answer, but he gives a formula, for which we refer our readers to his book.

The nitrate bath is prepared as follows:—

- A. Re-crystallized nitrate of silver 320 grains
- Distilled water 5 ounces.
- B. Caustic potash (avoid ammoniac) 2 grains
- Distilled water 1 ounce.

Mix these, and, when agitated, allow the precipitate to subside, and filter; fill up to nine ounces and add acetate of soda, previously dissolved in an ounce of water, three grains with five minims of glacial acetic acid. The bath is now ready for use, and should be tested for action with a wet collodion plate, developing with pyrogallie acid. If foggy, more acetic acid should be added, drop by drop, until the bath works clear; but the writer has always found the above proportions give good results. It will be observed that the bath is not, as usual, saturated with iodide of silver; the first plate may suffer a little if the weather be very warm, but it is simpler and safer, for reasons which will presently be stated, to leave it thus.

The washing and drying may be carefully conducted in the usual way; but the author enters into minute details, both in regard to these and other manipulations, describing the methods most successful in his hands.

For development he prefers the slow method with gallic acid, strengthening if necessary with pyrogallie acid and silver, or by some other of the known intensifying processes.

In regard to the class of negatives produced we may say that at a recent meeting of the North London Photographic Association, the chairman exhibited some of Dr. Kemp's negatives, which were very excellent in quality, but by which of these processes they were produced we cannot state.

Besides the full details of the processes of which we have given a copious synopsis, there is much incidental valuable information in the book. It is remarkably free from dogmatic assertion or egotistical claims, and is written in a winning courteous spirit, well worthy of imitation. The chapter on Photography for the Scientific Tourist and Missionary, is devoted largely to the consideration of the methods of securing portability, the use of either the collodion process, on mica plates, or of the Talbotype process being recommended.

Critical Notices.

A POPULAR TREATISE ON PHOTOGRAPHY, translated from the French of Dr. VAN MONCKHOVEN, by W. H. THORNTON, Ph. D., F.C.S. London: Virtue Brothers.

THE original of this work consists of an excellent epitome of the author's *Traité General*, compiled by two gentlemen, and corrected and endorsed by Dr. Van Monckhoven. The English edition is a free translation, with elisions, additions,

and modifications, by Mr. Thornthwaite. It is most profusely illustrated with engravings showing the forms of apparatus, or various methods of operating. We cannot entirely endorse all the ideas of the author, either as to processes or modes of operating, but we can recommend the work as a very complete, clear, intelligent, and, on the whole, trustworthy manual, leaving very little untold which ought to be stated in such a work, and stating still less that may not be followed with exact precision. This translation forms one of a series of rudimentary manuals originally published by Weale and Co., but now by Virtue Brothers.

CARD PORTRAITS, by Mr. Sarony, Scarborough.

WE have received from Mr. Sarony a handsome album of card portraits, amongst which we find some of the choicest gems we have seen. They are, for the most part, printed on enamelled paper, upon which a marvellously rich tone is obtained. The photography and the artistic taste are, in all cases, good, and, in some, perfect. As regards the photography, the pictures are all exceedingly brilliant, and the majority exquisitely soft and delicate as well. The definition is admirable throughout, although from the ease of expression in all, they would appear to have been taken with very short exposures. The lens, we understand, is Dallmeyer's No. 2 B. One of the especial features which strikes us is the easy, graceful, and natural posing, as well as the variety of effects, and absence of the common-place and conventional.

We have one striking illustration before us of the art power of photography. It consists of the portrait of a lady by Mr. Sarony, and another of the same lady by another person. The latter presents a somewhat common-place, coarse, plain-looking woman; the former a pleasing, graceful portrait of a lady. One is angular, hard, and square; the other is soft, delicate, and pleasing, if not beautiful. There are some of the pictures in this album, which, from the beauty of the model, the sweet expression, and graceful pose, the rich and well arranged accessories, and perfect photography, are amongst the choicest gems we have seen of photographic art. The frontispiece of the album is a clever idea, which, possibly, some others of our readers will be tempted to imitate. It consists of a card picture with a pleasing design, and made by the arrangement of card portraits. A pair of inverted cornucopias form an arch at the top; from these are flowing, on each side, streams of card pictures arranged in good lines. A medallion portrait of the Queen, and the address of the photographer, are in the centre. A neat border, formed of card portraits cut into ovals, runs round the outside. The effect of the whole is so good that it will readily find a place in any album, where it becomes a capital mode of announcing the name and address of the photographer.

A NEAT MODE OF WASHING SENSITIVE PLATES.

ON a recent visit to the studio of Mr. England, we were pleased with a very neat and simple contrivance which he used for washing sensitive plates, both during the preparation of the plate for a dry process, and also during the development of negatives produced on dry or wet plates. The method to which we refer has the especial advantage of being easily contrived by any one, and of being as inexpensive as it is efficient. It consists of an india-rubber tube attached at one end to a vessel containing water and having at the other end which hangs down an American clip. A hole sufficiently large for the tubing to pass through is made in one limb of the clip, the tubing is then pushed through so as to project about an inch beyond the biting end of the clip. The tube thus compressed, as by a spring tap, is quite water-tight when hanging at rest. When required for use, the slightest pressure opens the clip sufficiently to allow the water to pass through in a gentle stream, largely under

the control of the operator. The following outline sketch will make the matter more clear.

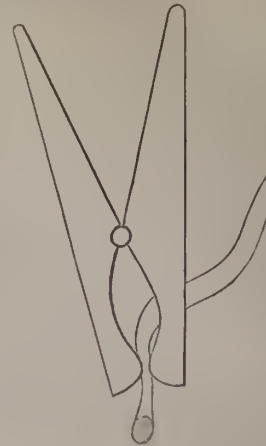

It will readily be seen that a very efficient washing can be given to the plate, with very little danger to the film, by using this contrivance. The stream can be directed on to any part of the plate at the will of the operator without approaching the edges or tender parts of the film. The fall of water from a tap often proves fatal to delicate films, and the use of a jug is troublesome. To those amateurs whose supply of water in the dark room is limited, the plan will be found a great convenience, as by the careful and slow application of a gentle stream of water a more efficient washing can be given than by the hasty and uncontrolled flow of three times the quantity. The simplicity and cheapness moreover, of the contrivance recommend it for a trial.

Scientific Gossip.

EBULLITION OF WATER—BUMPING—AFFINITY OF WATER FOR DISSOLVED GASES—OXYGEN FROM BROMINE—DECOMPOSITION OF WATER BY HEAT—POSSIBILITY OF SEPARATING NITROGEN FROM WATER.

IN boiling water in a test tube every one must have noticed that the phenomenon does not take place with uniform regularity. Numerous small bubbles rise from the heated part of the tube as the temperature approaches the boiling point, and that being reached ebullition proceeds for a brief time without any noticeable occurrence; soon, however, the bubbles of vapour rise from the bottom of the tube at longer intervals until at last the general character of the boiling liquid has the appearance of a perfectly quiescent tube of water affected at distant intervals with sudden and violent burst of vapour which have an almost explosive energy. The different phenomena here described attracted the attention of Mr. W. R. Grove, F.R.S., about sixteen years ago, and he has lately given before the Chemical Society an account of some very curious results at which he arrived in the course of this investigation. Some very remarkable observations on the ebullition of water were published many years ago by Professor Donny, of Ghent, and it was these statements principally which induced the author to study the action of heat upon various liquids under different degrees of atmospheric pressure and other alterable circumstances. Everyone is acquainted with the fact of water boiling quietly in an open saucepan, whilst the same liquid behaves very differently when heated in a long glass tube drawn out to a fine point, which, permitting the escape of the steam, would not allow the water again to absorb the gases of the atmosphere. Under these circum-

stances the "bumping" or convulsive ebullition which is also to be noticed in the distillation of sulphuric acid, was observed; and if further the air-pump were employed to facilitate the extraction of the air from the water it might happen that the application of heat would induce a sudden and violent escape of vapour amounting almost to an explosion. Another illustration of this fact could be seen by placing a flask with a little hot water under the receiver of an air-pump and then arranging in connection with the same a platinum wire which could be heated to a tolerably constant temperature beneath the surface of the water, by means of a galvanic battery. On exhausting the air it would be found that the ebullition only occurred at intervals, often a minute would elapse and then a burst of vapour would almost eject the contents of the flask. This over, the water would again become perfectly tranquil and remain so for another minute, when another tumultuous ebullition would occur, to be succeeded by a period of rest; and the same phenomenon would be repeated at such regular intervals that the apparatus might almost serve as an indicator of time. If a thermometer were placed in the flask it would be found that the temperature alternately rose and fell some few degrees. Indeed it could not be asserted that the boiling point of water was constant, for it depended upon the amount of air in solution, and the author believed that no one had yet succeeded in observing the boiling point of absolutely pure water. As a proof of the difficulty experienced in entirely expelling the air (or dissolved gas) from water, Mr. Grove cites the following experiment:—A long glass tube closed at one extremity was bent in the middle nearly to a right angle; the closed limb was then half filled with water, from which, by long boiling, the air was supposed to have been expelled; the remaining space in the tube was then completely filled with olive oil, and the open extremity was dipped into a small basin of the same. Heat was now applied to the tube until the water boiled, and this temperature was maintained for a considerable time. Each bubble of steam which left the surface of the water passed through the column of oil, becoming smaller and smaller during its ascent, but never did it condense without leaving a microscopic bubble of gas, which at length accumulated to such an extent that it could be examined. It was found to consist of pure nitrogen. The author had never succeeded in expelling the whole of this gas from aqueous solution even upon evaporating the entire bulk of the water itself; the evaporation of nineteen-twentieths did not secure the immunity from nitrogen of the remainder. On boiling ordinary water, air containing a slight increased proportion of oxygen was first driven off, the oxygen gradually diminishing until pure nitrogen was expelled. The avidity with which such water again absorbs air is remarkable. In the expressive words of Mr. Grove, "it sucks it up again almost as a sponge takes up water." By a slight modification in the apparatus the experiment was repeated with mercury instead of oil, in contact with the boiling water. It furnished a similar result. Mr. Grove next took bromine in order to test the possibility of converting into vapour an absolutely pure liquid. This elementary substance was boiled for a long time in a long glass tube, the extremity of the tube was sealed at the blowpipe and the contents afterwards examined. It was discovered in this instance that a certain amount of pure oxygen occupied the space above the liquid bromine. The liquid chloride of iodine behaved in a precisely similar manner. Even sulphur and phosphorus when strongly heated in a closed tube over mercury gave off in each instance a gas which proved to be either sulphuretted hydrogen or the non-inflammable modification of phosphoretted hydrogen.

With respect to the decomposition of water by heat, Mr. Grove described several experiments which indicated clearly the power of a heated platinum surface to effect the disunion of the gaseous components of aqueous vapour. Water was kept boiling in a long upright tube, the closed upper extremity of which had a loop of thin platinum wire

sealed within the glass: by connecting this wire with a battery, and passing an electric current sufficient to heat it to redness, it was found, by condensing the steam, that a small bubble of oxyhydrogen gas, mixed with a little nitrogen, remained. The volume of explosive gas did not, however, increase, for a state of equilibrium was soon arrived at, when the degree of dilution by steam was sufficient to counteract the tendency to recombination, but the author had, by a different arrangement, succeeded in augmenting this effect. For this purpose he used a glass bulb for the insertion of the platinum wires, and the steam partly decomposed escaped through a constricted passage into another tube or limb of the apparatus, where it was altogether out of the influence of the heat which would have caused its explosion. For the more rapid decomposition of water, an apparatus was devised in which steam, being disengaged from a silver generator, was passed through a short tube of platinum, intensely heated by means of a blow-pipe flame; the mixed gases resulting were swept out of the apparatus as soon as produced, and might be collected in notable quantity.

A number of striking facts regarding the solubility of gas in water were finally enumerated. The general conclusion drawn from the foregoing experiments being to the effect that water had a very powerful affinity for the gases of the atmosphere; that by several processes the oxygen could be eliminated, but the nitrogen resisted all attempts to expel it from solution; so much so that it might be doubted whether chemically pure water (*i. e.*, a compound of the two elements oxygen and hydrogen only), had ever been prepared; and further, that ebullition (as applied to water), under all circumstances, consisted merely in the production and disengagement of bubbles of aqueous vapour formed upon a nucleus of permanent gas. The question, therefore, was raised as to whether nitrogen is so absolutely inert a body as had formerly been supposed? Many facts seemed to show that there was some hitherto undetected relation subsisting between nitrogen and water, for they were always associated together in nature, and once combined, their disunion appeared impossible.

THE IRON PRINTING PROCESS.

A CORRESPONDENT of the *American Journal of Photography* describes another modification of the Iron Printing Process. We do not remember that oxalic acid has been used in clearing the whites; in other respects the process does not appear so useful as that which Mr. Reynolds described a year and a half ago. The correspondent above referred to writes as follows:—

"The 'blue process,' of which I send some specimens, presents very soft pictures, free from all the sharp or harsh effects which the same negatives would produce in ordinary printing. For this charming novelty in our art, we are indebted to Mr. Matthew Carey Lea, of this city, a gentleman of fortune, leisure, and high scientific attainments. He does not lay claim to the discovery of the sensibility of peroxalate of iron to the action of light, being aware that Herschel long since proposed its use for photographic purposes, and that, like many other important matters, it has been lost sight of from time to time, and periodically *re-discovered*. The usual course has been to develop simply with ferridcyanide of potassium. This always affected the whites to a very considerable extent, and rendered a *previous washing* necessary, which greatly injured the force of the proof without more than partially protecting the whites.

"As the whites contained unreduced persalt, it seemed probable that their discoloration was in some way caused by the production of prussian blue, whereas the picture proper was composed of Turnbull's blue, $3 \text{FeCy}_2, \text{Fe}_2 \text{Cy}_3 + x \text{HO}$. Recollecting that the former of these blues was soluble in oxalic acid, and the latter not or less so, it occurred to Mr. Lea that that acid might be available for obviating the difficulty. Experimenting proved this to be the case. The

preliminary washing was dispensed with, the excessive over-printing previously required became unnecessary, and the print was developed with a force and beauty, and a perfect clearness of the whites, of which the process was previously ineapable. It became the subject of many experiments to decide whether it was most advantageous to introduce the oxalic acid before, with, or after the developer; and from his trials he has adopted the conclusion that, in over-printed proofs the first is the best, in rightly timed prints the second, and in cases of over-exposure the third. In this employment of the oxalic acid to clear the impression, to un-blue the whites, and thus soften the shading as well as preserve the lights, Mr. Lea is believed to be the originator or inventor: without his improvement such a process could never be satisfactorily employed.

"The process as now laid down is simple, and as sure as it is simple:—

"Process.—Float the paper for a very short time (say a minute at most), on a solution of the double salt peroxalate of iron and of ammonia. Dry it thoroughly in the dark. Then expose under a negative for a short time (which will, of course, vary according to intensity, season, &c., but need never exceed three minutes in the sun); on re-entering the dark room, no impression is visible upon the paper, but the print will start up (about as quickly as a collodion picture under iron development), when immersed in a developer of—

Saturated solution oxalic acid	4 parts
Red prussiate of potash (ferrideyanide)...	1 part
Water	25 or 30 parts.

The print very soon reaches its maximum, and requires but little after washing.

"In consequence of the great sensibility to light, the exposure is so brief that printing can readily be done in rainy and dark weather. It works perfectly in the enlarging camera. The printing and development are so easily and promptly accomplished, that many galleries will probably adopt the process for exhibiting a proof to a customer as soon as the negative has dried.

"I have been agreeably surprised in finding that the sensitized paper has kept well (in the dark) for forty-eight hours. I use the same developer in a dish for a number of prints. The oxalate bath must be carefully preserved from the light; I coat my bottle with black paper.

"The double oxalate is prepared by either dissolving hydrated peroxide of iron to saturation in binoxalate of ammonia; or else by dissolving peroxalate of iron in neutral oxalate of ammonia."

ART IN PHOTOGRAPHY.

BY M. BLANQUART EVRAUD.

PRACTICAL METHODS.—MANIPULATIONS.

1. *Action of Light.*—It was our desire to delay the publication of this article, in order to perfect our means of execution, but the approach of the photographic campaign, and a wish to escape the reproach that might be laid against us of insufficient information, if the results that must follow the application of our theory are not obtained, does not permit of our delaying longer.

We have stated that it was possible to continue, out of the camera, the action of light upon the image formed, so as to give to this image more intensity.

We conceive that, from the possibility of lighting the whole, there results that of lighting certain parts only, at pleasure, by screening from the action of light those parts which we desire to preserve in their primitive state.

How to obtain this result is what we now proceed to describe. But we hasten to say that we have no intention of giving artistic instruction in this place. Art will not proceed from chemical manipulations and reactions; art is

the selection of effects. We shall point out how to obtain them, not where they must be produced.

Sacrificing certain parts of a subject to bring out others with more powerful effect, with only ordinary lighting, as in a magic picture by Rembrandt, or to demand from nature a vivid and piquant lighting, as in the Spanish school,—the photographer can in future arrive at both of these results with the same material appliances.

Let us, in the first instance, state that we give a certain preference to one kind of negative over another. Thus, pictures of medium intensity, rather weak than strong, are those with which we are best satisfied, and for this reason. Their deficient intensity causes them to be rejected in practice, because in printing they yield dark positives without brilliancy in the lights, but this condition is very favourable. All the parts which we desire to retain in a state of comparative obscurity we require to be in the primitive state of the negative; that is, we protect these parts from the action of light while we submit the others to it.

To make these reserves is a very simple matter, with a miniature-painter's brush filled with opaque pigment ground in oil or in varnish, we draw as accurately as possible on the back of the negative (which is not covered with collodion) the outline of the parts which we wish to protect from the light. When this line is well defined, which, as the negative is transparent is extremely easy, we cover those parts with opaque pigment.

In this state we expose the painted side of the negative to the sun.

The luminous rays traversing the parts not covered by paint, it is upon these only that their colouring action is exercised.

It may be conceived that in this manner we may perfectly succeed in defining the parts we wish to be acted upon and those we wish to reserve.

Sufficient sharpness is obtained almost without any precaution. Besides, there will be as absolute a sharpness as can be obtained by the point of the graving tool, if we expose the negative upon a movable frame, moving it according to the meridian and the height of the sun above the horizon, so that the rays may always traverse the negative perpendicularly through the thickness of the plate.

The mass of great lights being obtained, the operation of the reserves may be continued at will; we then cover with pigment all those parts considered sufficiently lighted to expose anew to the light only those which require to receive a more intense action.

It may be seen that we can thus vary to infinity the luminous effects, as we can graduate at discretion the luminous intensities.

When it is supposed that the desired effects are obtained, the pigment on the back of the negative is removed: it requires only ordinary talent to appreciate the value of the lights produced.

It is scarcely necessary to say that, if the desired effect is not completely attained, it is only necessary to re-expose to the light the parts which require to be more strongly impressed; here our task is similar to that of the engraver, who "touches up" his plate until he obtains the desired effect.

Of Dis-Iodizing.—The action of the light (exposure) being terminated, in proceeding to dis-iodizing, we have at our disposal two methods to follow, according to circumstances or choice.

If the negative be strongly coloured, and with the intensity necessary to yield brilliant positives in printing, it is sufficient, in order to dis-iodize it, to introduce it into a bath of hyposulphite of soda. We watch the action of the re-agent which, in dissolving the iodide, causes the pearly hue of the collodion film to disappear, and renders it quite clear and transparent.

If, on the contrary, for want of time, or from not having at our disposal rays of the sun strong enough to act with great energy, we conclude that the negative has too little

intensity, it must be submitted to the action of chloride of gold, according to the valuable method indicated by M. Fizeau for daguerreotype plates.

We will briefly describe this method for the benefit of those among our readers who have not practised daguerreotype. Upon a plate carefully levelled upon a stand pour a solution of *sel d'or*, as thick as possible; the picture thus covered, the plate is warmed over a spirit lamp. Under the action of heat the gold is precipitated, and the picture changes colour. In the present case we replace the daguerrian metal plate by our negative on glass, which we submit to the same kind of treatment: from a grey or red hue the picture acquires a deep black hue, viewed as a transparency, and bronze green when viewed by reflected light.

Opacity will naturally result from the quantity of gold precipitated; therefore we heat it strongly to obtain an abundant precipitate, and employ a very strong solution of gold (one part gold to one hundred parts of water).

This process, as may be seen, is of itself an excellent mode of strengthening, for, far from fogging the shades and thickening the lights, as but too frequently happens in repeating the silver solution, it gives great firmness to the lights, without impairing their limpidity; and in place of fogging the shades it clears them, so to speak, by a commencement of solution of the iodide of silver in the collodion.

But in the special case that now occupies us, it has a more precious value than if it acted only as a simple strengthening—it is that of producing a much more energetic action on the points acted upon anew by the light, than upon those which have been protected; in our practice we are also almost always tempted to submit all our negatives to chloride of gold, before proceeding to dis-iodizing.

After the chloride of gold has cooled, the excess is collected to serve again, after the addition to it of more chloride, in order to maintain the strength of the solution; the negative is afterwards submitted to the action of hyposulphite of soda to be dis-iodized, then washed in abundance of water and dried.

Of the Shades.—It has been remarked that when we have to treat a thin negative, such as certain reducing agents, and especially acid sulphate of iron yield, we can utilize as shaded parts, for the general effect of the picture, those parts of the negative which we have withdrawn from the new action of light. By these simple means it may happen that we obtain sufficient shade. If however, we do not, and it becomes necessary for the effect, to sacrifice certain parts still more, the following is the method to be employed to obtain this result.

Upon a piece of paper placed upon the back of the negative, trace the outlines of the parts to be put into shade, cut out this outline in thick paper or cardboard, so that when this cardboard is applied to the proof, the open parts leave exposed the spaces upon which we must operate, and that the full parts cover the spaces to be reserved.

Then prepare a dish which is placed upon a truly horizontal plane, spread upon it a coating of iodine, and place the negative covered with its card screen upon the dish; the fumes of the iodine go to the parts of the image remaining uncovered, and form with the metal an iodide of silver. The coating is thick in proportion to the length of the exposure.

The iodide of silver being soluble in hyposulphite and its analogous salts, it is sufficient to pass the negative rapidly through it to dissolve all the iodide formed.

By these means we may carry the shades to any depth we choose, as we can, if desired, convert all the metal into iodide.

The degree at which the iodizing must be stopped cannot be taught; experience only can show it, but the operator may easily arrive at judging of it by the colour the proof assumes.

We may comprehend also, that it is always prudent to keep below the effect, as we can always recommence the operation; the negative, dis-iodized, washed and dried, may

be submitted to the action of iodine, until the picture is completely absorbed.

We will conclude by a remark that is not without importance; it is, that the iodizing presents less danger when the negative has been passed through chloride of gold as indicated above. The layer of gold covering the silver checks the action of the iodine, and thus permits of conducting it more surely to the point at which it is useful to stop it.—*Le Moniteur de la Photographie.*

PREPARATIONS EMPLOYED IN THE COLLODION PROCESS FOR POSITIVES.

BY CHARLES WALDACK.*

DEVELOPER FOR POSITIVES.

THE substances used in the developing solution are as follows:—Sulphate of the protoxide of iron; acetic acid; alcohol; water; nitric acid; nitrate of potassa; nitrate of silver.

SULPHATE OF IRON.—Recrystallised sulphate of iron is sufficiently pure. This salt has to be put in a well-stoppered bottle to prevent its becoming yellow on the surface, and efflorescing.

ACETIC ACID.—Either glacial or common acetic acid may be used. The latter is generally three times as weak as the former. Acetic acid must be free from sulphuric, sulphurous, and hydrochloric acid, as well as from all tarry impurities. Commercial acetic acid of the best quality is in general sufficiently pure.

ALCOHOL.—Ordinary alcohol may be employed.

WATER.—Either rain or distilled water may be used.

NITRIC ACID.—Nitric acid must not contain any hydrochloric acid. It is preferable to use nitric acid chemically pure.

NITRATE OF POTASSA OR SALTPETRE.—The nitrate of potassa must have been refined. That which is used for the manufacture of gunpowder is the best. The impurity most to be feared is chloride of potassium, which, if it were present, would precipitate the silver in the state of chloride.

NITRATE OF SILVER.—The nitrate of silver of the bath is generally used.

Collodion positives may be divided into two classes: one in which the whites are dead; the other possessing brilliant and more or less metallic whites. These two classes of prints are obtained by two different developers. Thus the positives with dead whites are developed with a solution containing much iron, and, consequently, more rapidly. The brilliant positives, on the contrary, are developed with a weak solution, rendered still less active by the addition of nitric acid.

The following are the formulæ for the two solutions in question:

FOR DEAD WHITES.

Sulphate of iron	3 drachms
Water	6½ ounces
Acetic acid (commercial) ...	4 drachms
Alcohol	3 "
Nitrate of potassa	30 grains.

FOR BRILLIANT AND METALLIC WHITES.

Sulphate of iron	2½ drachms
Water	12½ ounces
Commercial acetic acid ...	2 drachms
Alcohol	3 "
Nitrate of potassa	1 drachm
Solution of nitrate of silver ...	1 "
Nitric acid	20 drops.

In those formulæ the salts are pulverized and dissolved in the water, after which the other ingredients are added. Care must be taken not to add nitric acid directly to the sulphate of iron in a solid state, because the latter would be oxidised and transformed into the sulphate of the sesquioxide, which is not a developer.

* *Humphrey's Journal.*

The effect of nitric and acetic acid is to preserve the blacks and to render the whites more brilliant. Both nitrate of potassa and nitrate of silver produce also the same effect. Alcohol is added to cause the solution to flow easily over the plate without separating from the surface and without producing grease marks.

The preceding formulae have been verified by practice. We do not pretend to give an explanation of the peculiar effect of each of the substances contained therein. Why, for instance, are acetic and nitric acids used in the same preparation, since they are supposed to produce the same effect? It is possible that the second formula which is here given, might be simplified, but we prefer giving it such as it is, for we have always had good results from it. This is the one which we specially recommend.

The editor of *Humphrey's Journal* adds, on publishing this article: "It works magnificently, and especially with a white background, producing an effect of roundness more like that of a daguerreotype."

SCIENTIFIC PHOTOGRAPHY.

BY M. ERNEST LACAN.

THE human jaw-bone that has recently been found in the *diluvium* near Abbeville, a geological stratum in which no similar vestige has hitherto been discovered, has been photographed by M. Potteau, of the Museum of Natural History, to whom we are already indebted for an interesting collection of the various races of mankind.

We have before us two proofs representing the two sides of this curious *débris* of a generation, the existence of which, in all probability, refers to the pre-historic period. It is the half only of the lower maxillary bone, in a truly extraordinary state of preservation.

From observations which have been made, and which we owe to the kindness of M. de Quatrefages, this jaw belonged to an old man of short stature, which tends to prove that the human race had not, at its origin, those gigantic proportions which certain hypotheses have assigned to it. The angle of the external contour is more open than in the modern types, but upon examining two Esquimaux jaws we saw that in one this angle was still more open, and in another much less. This is, therefore, a characteristic belonging to the individual. A molar tooth remaining in its place, appears also more inclined forward than in ordinary cases; but this fact is explained by the absence of the adjoining tooth, which had been extracted or had fallen out during life-time (for the work of ossification had taken place, as usual, in the alveolar process). This, therefore, is nothing but an individual peculiarity.

Other less important observations, which may be repeated on the photographic proof itself, give the same result.

The discovery of this fossil jaw has caused a true scientific tourney between the French and English *savans*. If victory remains with the first, their adversaries have possessed the rare merit in duels of this kind, of frankly and courteously acknowledging their defeat.

To give some idea of the minuteness of the investigations entered upon, so as to remove any doubt that might exist, we give a summary of some of the curious details with which we have been kindly furnished by MM. de Quatrefages and Milne Edwards, fils.

After examining the jaw found by M. Boucher de Perthes, M. de Quatrefages repaired to the mill at Quignon, where the excavations were made, to study the ground. He examined the place where the jaw had been found, and struck a pickaxe into a spot at about the same height from the ground. A quantity of flints were removed and among those that fell he found an axe-head of flint, similar to those of which we already possess numerous specimens. Upon examining the spot which had been attacked, M. de Quatrefages found almost entirely embedded in the soil a second axe-head, which he removed himself. This latter, at least,

could not have been fraudulently introduced, and its presence was a guarantee of the authenticity of the human *débris* found in the same place. Upon this the learned Professor made his first communication to the Academy of Sciences. Mr. Falconer hastened to Paris, examined the jaw-bone and axe-heads, and appeared convinced. However, after a few days spent in further observations, he published in the *Times* a letter which expressed more than a doubt. M. de Quatrefages thereupon resumed his examinations, and replied to the criticisms of his friends across the Channel. The latter then decided that they would proceed to Paris to witness, in company with certain persons they should designate, the investigations of which M. Milne Edwards had spoken in his communication to the Committee of Learned Societies.

Three principal points served as the base to the doubts of the English professors; viz., the nature of the envelope of the jaw-bone and axe-heads, the freshness of the edges of the latter, and, lastly, the presence of a little sand in that part of the jaw-bone through which passed the dental artery. M. Delesse declared that it would be impossible for any chemist to counterfeit the substance of which the envelope was composed. Five axe-heads were successively found in the presence of the persons making the inquiry, and they each and all had the same characteristics as those previously dug up. Lastly, over the black stratum, where the maxillary bone rested, a sand was found exactly similar to that observed in the alveolar process of the jaw-bone.

After these proofs, the English *savans* declared themselves convinced that the jaw-bone had not been fraudulently introduced into the stratum of diluvium, and that it was contemporary with the materials composing that stratum.

As to the question of ascertaining the date of the formation of the soil, it remains to be solved, for M. Elie de Beaumont denies that this soil really belongs to the diluvium. Such is the position in which this interesting debate stands.—*Moniteur Universel*.

ABOUT COLLODION, ETC.

BY J. MILTON SANDERS, LL.D.*

SUCH a vast amount of literature, good, bad, and indifferent, has been written upon the subject of collodion, that to attempt an article upon it this late day, seems really live folly. But something can be said that may be valuable, upon the most trite and threadbare subject, provided that it is built upon indicative experiment. Like hundreds of your photographic brethren, we, too, have made many experiments upon collodion.

The whole tribe of iodides and bromides have been enlisted in our service, not to mention likewise the fluorides and chlorides. As for the proportions in which we have combined them, the mere enumeration would be equivalent to burthening an entire column of the photographic journal with meaningless formulæ.

In order that you should get good collodion, it is quite necessary that all of the materials should be perfectly pure. This has been so frequently mentioned by others, that it would appear superfluous here; but to bring it to the meditation of the reader, is again necessary. It would be invidious to dwell particularly upon the cotton and chemicals of any particular manufacturer, but while we mention that we use none but those prepared by Seely and Co., we would not by this depreciate those of other chemists. The iodides and bromides should be mixed in the proportion of the equivalent number of their radicals. We find that these proportions give much more satisfactory results than in other proportion. The film yielded by them possesses the property of great tenderness, creaminess, and sensitiveness, while the collodion resists the action of time better than any other I have ever yet used. The manner of preparing this collodion

* *American Journal of Photography*.

is as follows:— Into a bottle of a full pint capacity, I pour eight ounces of pure ether; then add to it eighty grains of gun-cotton. After the cotton has become thoroughly saturated with the ether, I then add eight ounces of pure photographic alcohol, when a slight agitation will cause the cotton to dissolve. I then add eighty grains of iodide of cadmium, and sixty grains of the bromide of the same metal; shake and they will soon dissolve, and the collodion is made. The above proportion is nearly in round numbers those of the equivalents of the radicals used.

It has been asserted by some writers, that bromine had a tendency to render the film less dense and less sensitive. I find, after having made hundreds of experiments, that the reverse is the case. The sensitiveness of the film so highly bromized, is considerably increased, and the toughness likewise. The most delicate half-shades are yielded by this film, either in negatives or positives.

We would mention in conclusion, that we never acidify a bath with acetic acid. Nitric acid, the one that silver is combined with, it is that we use. It is the acid that should be used for the purpose of acidifying the bath, provided an acid be necessary at all, for we find that the majority of nitrate of silver is just acid enough to answer the purpose of a bath without the addition of any acid whatever. If known, it should become necessary to acidify the bath, use nitric acid and you will avoid much trouble. When we were in the habit of using acetic acid in our bath, we were frequently in trouble, the plate presenting those familiar aspects so well known to the photographer, such as spots, streaks, mottlings, thin translucent films, &c. All of these may be avoided by using exclusively nitric acid.

Some have asserted that this acid yields films less intense than acetic acid, but we have not found this to be the case; while there is one advantage, that whiter and finer ambrotypes are the result.

And finally, we would conclude this article by mentioning that, like perhaps many other photographers, we have entirely discarded alcohol from our developer. The alcohol, many photographers inform us, is necessary to assist the fluid to flow evenly over the plate. We find no difficulty in flowing the non-alcoholic developer over the largest plates, then wherefore the necessity of alcohol? When there is no necessity of an article, wherefore its use? By the non-use of alcohol we avoid many disagreeable marks upon the film that once troubled us.

This is the place where we had intended to bring this paper to a close, but a few words more on the cleansing of the bath. It was the discovery of Professor Seely, and was first announced by him, that the direct rays of the sun did not actually ruin the bath, as was then universally believed, but on the contrary, they purified it. As soon as our bath begins to exhibit symptoms of "general debility," as the doctor would write it, we pour into a shallow, open basin, and set it in the sunshine. The organic matter, together with a small portion of silver, will be precipitated, while at the same time the alcohol that the bath contains will evaporate. It would perhaps be well to mention that, before the exposure of the bath, the acid in it should be neutralized, as organic matter is soluble in acids.

The bath should be then exposed for about one hour, when it should be filtered, slightly acidified with nitric acid, and our word for it you will find it to work, with the above collodion, like a charm. If it does not, you may consider your bath so far beyond "general debility" as to be at the point of death. The best way, in the latter case, would be for you to precipitate your silver as the carbonate, dissolve this in nitric acid and make a new bath.

In the above, we yield to the imputation that we have written some things which are old; but you should recollect that all old things are not unworthy of attention, even in this age when new things appear to be the rage, whether they possess merit or not.

IMPURITIES IN ALCOHOL.

THE question whether the use of methylated spirits in collodion is really injurious, is not decided. We are of opinion that conclusions as to its injurious operation have been too hastily arrived at. It may be, however, interesting to possess a certain method of detecting the presence of wood spirit by certain tests, although the sense of smell will readily detect it when present in any serious amount. Mr. E. J. Reynolds, in a paper recently read before the Royal Dublin Society, proposes the following method of detecting the presence of any trace of the wood spirit.

A small quantity of the suspected liquid is distilled, and to the distillate a little dilute solution of chloride of mercury (corrosive sublimate) is added, and finally excess of caustic potash. The whole is then warmed, and, if it be found that the oxide of mercury first thrown down is not redissolved, wood spirit is not present. If the excess of potash and subsequent heating of the liquid causes the re-solution of the oxide, it is divided into two parts. To one *acetic acid* is added cautiously this causes the formation of a yellowish bulky precipitate after a short time. The remaining portion is boiled strongly, and a similar precipitate is thrown down; thus proving with certainty that wood spirit is present. In applying this test, it is necessary to be careful not to add too much of the mercurial solution, otherwise an insoluble compound would be formed, and, as a consequence, a negative result arrived at. It seems this reaction is due to *acetone*, an invariable constituent of wood spirit.

The following on other falsifications of alcohol is from *L'Invention*.

Alcohol, as we all know, is the product of the distillation of sweet liquors; we draw it by the distillation of wine, of cyder, of beer, and all liquids which have undergone aleoholic fermentation. The wines which are gathered in France are not all destined to be consumed in nature. A part of the wines of the Meridian, from raisins (meaning grapes) rich in sugar, are converted into alcohol by distillation. We choose generally the white wines, which do not contain more alcohol than the red wines, but which furnish one more fine and straight in taste; the alcohol which comes from the fermentation of raisins is ordinarily impure. It contains an essential oil which gives it in some cases an agreeable savour, in others a taste disagreeable. One can at least detect the presence of this oil in the alcohol of wine not rectified. In spreading the liquor with six parts of water and distilling it with precaution, it remains in the *cornue*, an oily layer. This oil is very abundant in the brandies which come out of the *marc* of the vintage; it is produced principally by the pellicles of the grain; one hundred litres of alcohol, separated, contains twenty grammes of this oily matter formed of the oil of the potato, of oily fat; of which a single drop suffices to infect one hundred litres of brandy. One can separate this oil of alcohol by a distilling pipe with management; in fact, the alcohol drinks at about eighty degrees, and the oil in question does not enter into ebullition but between one hundred and thirty and two hundred degrees. The wines of the Dauphin and of the Vivarais of the Moselle give the alcohol which participates of the taste of *terroir*, that characterizes these wines.

It is, probably, to circumstances of this nature to which we must attribute the taste and *bouquet* in the old *eau-de-vie de cogniac*. During a long time brandy has been obtained through distillation by a naked pipe; unless one operates on white wine of a good quality, it is rare that we obtain an alcohol exempt from the taste of *marc*, or fire, contracted through this mode of distillation. The idea of substituting another mode for the one just mentioned belongs to Argand, the inventor of the lamp with a double current of air, *de quinquet*. The processes of Argand were perfected by Edward Adams, who operated with an apparatus of De Wolf's, in which the flasks filled with wine were heated by steam. One concedes that with this system, each flask, when unequally heated, gives an alcohol of different degrees. The processes of Adams were notably perfected by M. Blumenthal, who had recourse to a continuous mode of distillation, and knew how to combine the apparatus in such a manner that even during the drainage of the wines the distillation was uninterrupted. The wine arrives upon one side, while that which preceded it comes over upon the other, after having parted with the whole alcohol which it contained. This apparatus has, since M. Blumenthal, been perfected by M. Derosne, who prevented the depuration of some of the alcohol in the draining

of the wines. This last perfection was still more simplified by M. Langier. In submitting brandies to a new rectification, one obtains alcohol of three-sixths de Montpellier; it marks thirty-three degrees by the alcometer. The alcohol is received in vats, in which a part of the colouring matter is dissolved; this colouration becomes apparent as the sojourn of these liquids in barrels is prolonged. One is then disposed to allow more quality and *veluscity* to brandies which are coloured. Commerce sometimes cuts the three-sixths of Montpellier with water, and colours it with an infusion of caramel dissolved in tea, which seems to give this new brandy a taste of *veluste*, but it is rare that this falsification escapes an experienced taster.

Wine is not the only substance from which alcohol is obtained; the beet, grain, potato, certain fruits, such as chestnuts, cherries, etc., produce alcohol of a good quality, of which different kinds are consumed in brandy. Brandies are mixtures of alcohol and water, and contain about equal parts of both liquids; spirits, in commerce, is an alcohol which contains less water than brandy. The richness of a spirit is always determined by the real quantity of alcohol which it contains; it is not the same with brandy, its colour is not always proportionate to the quality of alcohol which it contains, more frequently it depends upon its age and growth. Experiments were at one time tried upon the spirits of commerce, by pouring it upon powder and then inflaming it, when the powder burned the spirit was judged to be of a strong quality; this is, however, no accurate test.

In France, the legal alcometer is that of Gay-Lussac; it expresses immediately the absolute quantity of alcohol which is contained in liquor; the experiment must be made at 15°, if the liquor has not this temperature it must be brought to it by the heat of the hand; for the rest, Gay-Lussac has given tastes of correction, which determine by the aid of the alcometer the quality of an alcoholic liquid taken at different temperatures. The principle of graduating this instrument is simple; when put into absolute or pure spirit, it is sunk to the point marked 100°, placed in pure distilled water, and it stops at the point zero, the interval between these two points is then divided into 100° by the aid of mixtures of alcohol and water in proportions which are known—this instrument indicates the relations of volume, not of weight. In commerce, Cartier's areometer or liquor-weigher is still employed; in this instrument water which is distilled marks 10°, and alcohol "anhydre," marks 44°. Brandy from wine, originally has a whitish colour, but by tarrying in open barrels it acquires by age the yellowish-brown coloration which it ordinarily has, and which is due to the dissolution of a part of tannin and the extract contained in the oak. This brandy thus coloured is blackened with a few drops of a solution of sulphate of iron. Brandy of a good quality possesses an aromatic odour, and a warm and clear savour, which is modified by time, the most esteemed brands are those of the Languedoc, of Montpellier, and the district of Armagnac.

THE STEREOGRAPH AND THE STEREOSCOPE.*

The stereograph and the stereoscope have been discussed in a scientific point of view until these subjects are exhausted; it remains now only to see whether there can be any other application of them than that which is already made of them, as well as also to show how stereographs are taken and copied.

THE APPLICATION OF THE STEREOSCOPE TO DETECT FORGERY.

If two engravings from the same plate be placed side by side and mounted as a stereograph, it is evident that, when these engravings are superimposed, either by the aid of the stereoscope or by the eyes alone, the resulting picture will be perfectly flat; whereas, if two engravings of the same object and of the same size be struck off from two separate plates, the one being a copy of the other as accurate as can be obtained by any artist whatever, or both plates pictorial representatives of the same object from the same point of view and worked by the hand, I have no hesitation in asserting that the superimposition of these will invariably produce a degree of pseudo-stereoscopia.

* Continued from p. 150, vol. vii.

Now, wherever such an irregular relief is thus produced, we may rely upon the accuracy of the deduction when we assert that the pictures are not produced by impression from the same plate. Such a deduction is the result of experiment. For instance, draw two very fine lines or arrows, each one an inch or so in length, and at the distance of two inches and a half apart; from the centre of each line, and with a radius a little greater than half the line, draw a circle; let these two circles finally be so arranged on a stereoscopic slide as to revolve round their centres respectively. So arranged place the slide in the stereoscope, and revolve the circles until the superimposed lines lie on the same plane with the circles; when this is accomplished, and it can be easily and very accurately accomplished, it will be found that the arrows are in exact parallelism with each other. The *slightest* deviation from this parallel position will elevate one end of the arrow and depress the other, so that it appears to be inclined to the surface of the circle. The perception of this phenomenon is very easy; therefore, the slightest irregularity in the position of the corresponding parts of two drawings so treated becomes manifest by producing relief where, if the corresponding parts were all accurately at the same distance apart, such relief could not exist.

Taking advantage of this peculiar property, means can be adopted to detect forgery, that is, to distinguish very easily and quite undeniably, a forged bill from a true one.

In order to apply this property to the bills of banks, where fraud is suspected, we proceed as follows:—Take a true bill of the bank and the suspected one, double them in the middle carefully, and place the similar halves of either on a stereoscopic slide side by side like the two photographs on such slides; make the surfaces as smooth as possible, and bring the corresponding lines of either to coincide so as to form, as it were, one and the same straight line. If these two bills have been struck off from the same plate, the superimposed picture will be flat; if, on the contrary, they are the impressions of two separate and distinct plates, one being a copy of the other, an irregularity of relief in the position of the words when superimposed will indicate the fact that one is either a copy or a forgery.

A second method of detecting forgery refers to photographic copies of bills, which, when superimposed with the original bills as above described, may produce a flat picture in the stereoscope. In this case the forgery is made apparent by the difference in the gloss of the written signatures or, where this fails, then a chemical experiment or two performed upon a minute point of the writing will set all doubt aside as to whether forgery has been committed or not.

Correspondence.

PHOTOGRAPHY IN NEW YORK.

New York, June, 4th, 1863.

DEAR SIR,—My statement that our great American globe lens was not up to the popular idea, has raised a dust around my head here, and has brought out a letter from the manufacturer, in which he says:—"We never claimed for the lens an angle of 100°, nor do I think it has been so stated in any publication except the English journals, and then ironically. The true angle is 75° or 80°, i.e., the lens will show a well-defined and equally illuminated circular field, including that portion of the horizon." The 75° I admit, and even 80° is included in this lens; which certainly covers a wider field than any lens yet sold,* but we were

* Our correspondent is here speaking in the absence of personal knowledge of the triple lens. The angle included by the globe lens is probably about 75° measured on the diameter of the circle of light. It is customary, however, to measure the angle on the horizontal line of the picture which can be cut from the circle. Such a step would probably reduce the angle included by the globe lens to about 60°. We have now before us an interior taken with the stereoscopic globe lens in which it has done its work well; we have also a view of the same interior taken with Dallmeyer's No. 1 triple, in which the work is also done well. But the square cut out of the circle given by

given to understand that the globe would take in 90°, which I think was not so. I know nothing of optics and, therefore, may be wrong when I say my idea of 90° is to set the lens thirty-seven and a half feet from the ground at a distance of thirty-seven and a half feet from a building seventy-five feet high and take in the whole height without curved lines or other distortion. The Harrison lens, however, certainly *does* do 75°, and does it well. This statement is due to the manufacturer, and I freely make it.

Photographically speaking, we have a dearth of news on this side the ocean, although the business of galleries and stock-dealers never was more brisk. I enclose *The Print* from which you will see that the amateurs are lively as ever. Mr. Guillou, of Philadelphia, has sent me some *blue photographs* which are quite curious and very beautiful. For some subjects this process (published in *The Print*) may be desirable, but it never can be used in any portraiture.

Some interest is excited here by H. T. Anthony's oxide of silver process. I have made some prints by it with great success, and am determined to adopt it in future practice. At the next Club Exchange I intend exchanging prints made with only fifteen grains of silver to the ounce of water.

Process.

Nitrate of ammonia	3 ounces
Filtered water	10 "

Shake up and thoroughly dissolve, and add moist oxide of silver to saturation. The moist oxide of silver is prepared by adding to a pint of twenty-grain solution of nitrate of silver caustic potash till all the oxide is precipitated. Wash the precipitate thoroughly to clear it of potash, and put all this wet oxide into the nitrate of ammonia solution. There will settle undissolved to the bottom of the bottle some oxide, which surplus serves to keep the bath saturated, and also to keep it clear. Add three drops of nitric acid to the ounce, and sensitize the paper by floating half a minute. After the paper is dry put it in the fuming box as usual before printing. If the albumen is soft and dissolves in floating, then add more nitric acid, and fume in the ammonia fuming box for a longer time to counteract the acid.

The extreme economy of this process is its recommendation. I will forward you some of these prints as soon as I get to rights in my "great den."—Very respectfully yours,

F. F. THOMPSON.

IRON DEVELOPER WITHOUT ACID.

DEAR SIR,—I have seen no remarks made on the formula for developing solution by M. Kaiser of Leyden (see PHOTOGRAPHIC NEWS, May 29th); its importance has seemed to me to make it worthy of investigation and trial, and from the perfect success of my first essay in development with iron without acid, I am convinced that it needs but to be made known again to be fully tried.

I employed honey in place of sugar of milk, as directed by M. Kaiser, and if any one will just perform the experiment of dissolving about equal parts of honey and water together (or make a strong solution of honey), containing a few grains (10 or 12 or so), of sulphate of iron per ounce, adding *no acid*, and mixing with it some nitrate silver solution, as in developing, he will at once perceive the great lapse of time before the decomposition of the nitrate silver will set in, far longer than with acid and iron developer. I next sensitized a plate, exposed, and developed it into a clear, vigorous and dense picture, using a like developer viz., sulphate iron, honey, and water; it may be an accelerator as M. Kaiser says, no acid being present, and it is so anomalous, after the hitherto received belief of acids being a

the globe lens includes less subject by several degrees than the square cut from the circle given by the triple. We shall send the prints in question to our correspondent for his examination. We are not undervaluing the capabilities of the globe lens, which is an ingenious invention, and for some purposes will be found useful; but we do not regard it as equal in general utility, or in the extent of angle embraced, to the triple lens.—Ed.

sine qua non with iron salts in development.—I am, Sir, yours faithfully,
Egham, June 23rd, 1863.

WILLIAM BARTHOLOMEW.

[We have used the saccharo-sulphate of iron in very strong solution, with not more than a fourth of the usual amount of acid with advantage. It gives a denser and a browner image than the ordinary iron developer. We may here mention in answer to several who have made inquiries, that Messrs. Hopkin and Williams at our request, prepared some of the saccharo-sulphate, and are doubtless prepared to supply it.—Ed.]

Photographic Notes and Queries.

CAUTION.

DEAR SIR,—On Thursday last a shabbily dressed man applied to me for work as an artist, pitching a sad tale of distress owing to his wife being an inmate of Hanwell Lunatic Asylum, trade being bad, &c., &c., his tale somewhat exciting my sympathy, I directed him to call again with specimens of his capabilities; he paid me a visit the day following, and during my temporary absence from the waiting room he made his exit with my great coat, the loss of which I did not discover until about three hours afterwards. As near as I can remember his description he is about 5 feet 8 high, dark complexion, small black whiskers, dressed in a black coat, black or dark diagonal pattern trousers, gave the address of Mr. Campbell, 5, Church Street, Knightsbridge.* The publication of this in your well circulated NEWS may probably put others on their guard.—I am, sir, yours respectfully,
R. H. DYBALL, Photographer.
3, Lower Notting Hill Terrace, June 23, 1863.

[We may here add another caution. An artist (possibly the same man) called upon a friend of ours, a first-rate photographer, and by a variety of considerations induced him to let him have some specimens to colour, on the distinct understanding that they were simply to illustrate his abilities and not to be paid for unless approved. He also borrowed some other coloured specimens as guides as to style. When he brought back his work the photographs were spoiled, and had become miserable dabs. He however demanded payment, alleging that he had painted them to order, and on meeting with an indignant refusal, he declared that he should keep the other coloured specimens lent to him, worth several pounds, until he was paid. So the matter stands.—Ed.]

DRY PLATE TROUBLE.

SIR,—I shall esteem it a great favour if you will afford me any information which may explain the following failure:—

I prepared a plate for the dry process, as described by Mr. Hislop, using Ponting's bromo-iodized collodion, as recommended.

I kept this plate three weeks in a light, tight box, then exposed to a sunlit view (twelve o'clock) for one minute, using Dallmeyer's No. 1 triple, half-inch stop. Upon developing, not the very faintest appearance of an image was visible.

This I do not understand, for though the plate may have been under-exposed, surely *some trace* of a picture should have been found?

My bath works well for the wet process, thirty-five grains to the ounce,—very slightly acid with acetic acid.

The collodion also works well for the wet process, though it is several months old.

If you can explain this failure, I shall be extremely obliged.

Are you aware whether the tannin and honey process still gives satisfaction? and whether the plates will keep—say three weeks after exposure—before development?

I obtained some of Werge's plate-cleaning fluid, as recommended in the last number of the NEWS, and find it most efficient. It is evidently nothing but *uniodized collodion* and methylated spirit.

I had been in the habit of using old collodion and alcohol, the action of which is precisely the same, though rather more expensive. Mr. Werge may well guarantee that there is

* Upon inquiry I find there is no such place.

nothing in it which will injure the bath.—I am, Sir, yours truly,

A DRY PLATE.

London, June 23, 1863.

[Did you redip the plate in the silver bath before developing? or did you add any silver solution to the developer? Unless you made this omission—a thing we have known done—we cannot offer a suggestion as to the cause. Perhaps some of our correspondents may have had some experience in such mishaps. Regarding Werge's plate-cleaning solution, you are right as to its efficiency, but altogether wrong as to its constitution. We were entrusted, in confidence, with the formula by which it is prepared, and except that, amongst other things, it contains ether, you are in error. Tannin and honey continue in many hands to give excellent results.—Ed.]

To Correspondents.

W. H. BISHOP.—If you took the portrait for your customer without any agreement as to copyright before any of the copies were sold, you have lost the opportunity of acquiring a copyright. If you took the portrait for yourself, you might have obtained a copyright in it by registering it before any copies were sold. But so far as we understand the case now, no copyright in the portrait in question either exists or can be procured by any one. You can get any picture registered in which you have a copyright at a cost of about 1s. 4d.

AN ENTHUSIAST.—The general plan of your room is good, but we should prefer the space over head without glass to be lengthened a little, and to have the amount of glass both top and sides a little extended to meet the necessities of dull weather and bad light.

TAYLOR.—We cannot tell you to what extent the enamel paper has yet come into general use, either in London or elsewhere, and it will always involve more trouble than ordinary albumenized paper. 2. The double sulphate of iron and ammonia may be used as a developer in solutions of various strengths, the same as the ordinary sulphate. See various formulae which have recently appeared in our pages. 3. The annoyance to which you refer is a common one, and many respectable portraitists feel it seriously. You can only prevent such copying by taking steps to secure the copyright in such portraits. We shall have something more to say on the subject shortly.

A. B. D.—The salt you enclose appears to be a preparation of iron, and appears on a hasty trial to develop in a similar manner to the ordinary sulphate. To ascertain if it possess special advantages would require careful comparative trials.

A CONSTANT SUBSCRIBER.—It is a moot point whether or not a person may copy a copyright picture merely for his own private use. It is probable that a strict enforcement of the Act would punish copying for any purpose whatever.

G. A. B.—The amount of washing you describe ought to be sufficient for a tannin plate; but some samples of collodion require much more washing than others. Did the spots or mottled marks show on the plate at all before development? If so, probably the collodion is unsuitable. Possibly the development was too hastily done, and without sufficient care as to cleanliness. The plate would have been better with longer exposure. Your cards would have been better for a trifle longer exposure and less development; the definition is wonderfully good for a stereo lens of 3½ inches back focus. The stain is due to a certain condition of the bath, sometimes very troublesome in hot weather. See that there is no floating scum at the top of the solution. We have not made sufficient experiment to fix authoritatively the best strength of solution with the double sulphate. We are using it 48 grains to the ounce, with 48 minims of acetic acid, with advantage. The saccharo-sulphate may be had of Messrs. Hopkin and Williams.

TANNO-GLYCERINE.—Gallic acid is soluble in cold water to the extent of about 4 or 5 grains to the ounce. There is a slight difference in the solubility of various samples; but the use of 5 grains to the ounce will in most cases produce a saturated solution. It is much more soluble in hot water, from 100 to 130 grains being soluble in an ounce of boiling water. It may be used hot, and is then for albumen and collodion-albumen plates a very energetic developer. It is better only to heat the quantity required for use. It is very soluble in alcohol, but we cannot state the exact limit. 2. When pyroxylene has become slightly acid from age or exposure, washing it in acetate of soda, or even in alkaline solutions, whilst it may remove the acid, will not restore it to its former condition. The acid can only be liberated by decomposition, and although the acid may be removed, the former condition is not thereby restored. We have not met with the decomposition referred to; but we have found that cotton prepared with moderate care does not easily decompose when kept for many months. We have kept samples prepared by ourselves upwards of twelve months without deterioration. You are right in the estimate of the book in question. The box has just arrived, but is not unpacked. We do not remember a suitable person for the undertaking, but will give the matter our earliest attention after returning from Paris, whither we go as soon as the present number goes to press.

SOL.—Your experience is unusual. When everything is in good order a good purple tone should be obtained in ten minutes, or a quarter of an hour, although, sometimes, it is longer. We prefer slow toning; but you can generally hasten it, when desired, by increasing the strength of the solution.

W. G.—We have occasionally known similar markings to those which you describe appear on the dry plate before exposure, without affecting the negative. Its cause we are uncertain of. Sometimes it is attributed to the use of an old nitrate bath.

HONORATO.—The best place for stops in a portrait lens is between the front and back combination. As a rule, they should occupy a position governed by the respective foci of the front and back combinations. To illustrate: suppose the focus of the front combination were six inches, and of the back twelve inches, and the distance between the lenses three inches, the position of the stop should be one inch behind the front combination, which would also be two inches in front of the back combination. You

can try some stops of blackened card-board placed in the position, and see if the result is what you desire.

R. H. COURTNEY.—We are sorry we did not see you. We will give the salt a trial shortly. It appears, on a single trial, to develop very well, but to give a thin image.

TYNO.—Your bath is probably super-saturated with iodo-nitrate of silver. Add its bulk of distilled water, neutralize, sun, filter, add silver to make up the strength, and try. 2. Mr. Leake in advising the use of an acetate in the nitrate bath, and at the same time speaking of the use of carbonate of soda, is of course speaking of acetate of silver, and in adding carbonate of soda, he will either have acetic acid present in the bath, or he will add it coincidentally with the carbonate of soda, and so form acetate of silver in the bath. If the collodion to which you refer reticulate, the only remedy is mixing it with another sample.

LANKA.—The coppery-looking deposit on the deep shadows whilst developing is a familiar trouble in this country during hot weather. We wrote an article fully treating of the matter last summer, which appeared on p. 251 of our sixth volume. One of the most frequent causes for its appearance is insufficient washing between different stages of the process, especially when using some spongy samples of collodion. An excellent remedy is to flood the film before intensifying with a solution of iodine one grain, iodide of potassium two grains, in one ounce of water, then thoroughly wash again before applying the intensifier. The best remedy when this deposit has occurred is to treat the finished negative with a very weak solution of bichloride of mercury, which will, without much affecting the general character of the negative, turn the red deposit white, and so make of little account in its effect in printing. 2. Are you sure it is a fungoid growth to which you refer, or is it what is termed a "sweating" of the glass? Any form of organic matter or fungoid growth ought to disappear on treatment with strong acid, nitric or sulphuric. If you have anything suitable for publication, we do not know of any house with better facilities for distribution, or who can give you better information on the subject than Marion and Co., 23, Soho Square. 4. You can become a member of the Amateur Photographic Association. You can receive full details from Mr. Melluish, the Secretary, 12, York Place, Portman Square. We shall have pleasure in proposing you. The subscription is a guinea a year, for which members receive two guineas' worth of prints. They must contribute at least six good negatives yearly. Members receive half the profits of sales of their own prints. 5. The addition of carbonate of soda and sunning will, probably, suit your baths best. 6. Our YEAR BOOK contains an annual *résumé* of improvements in the art. Major Russell has a second edition nearly ready. There is announced for publication, shortly, a work by Bland and Co., containing full information of latest improvements; and Mr. Hughes has a new edition of his manual in the press, which will contain, we believe, very full information on many topics. 7. For certainty the collodion-albumen process; for simplicity and general advantage the tannin process, or some of its modifications.

B. B. F.—In attempting open-air portraiture you will find a blackened hollow cone, about the size of a sugar-loaf, attached to the lens, so as to project in front, will materially aid you in getting clean shadows. Your negative is evidently somewhat fogged from diffused light entering the lens.

JOHN ALEXANDER.—Your Voigtlander of 5½ inches focus will, probably, answer for instantaneous views, although its aperture is not quite so large in relation to its focus as Dallmeyer's new stereo lens, regarding which you inquire. His No. 2 B is most suitable for cards. The information you require on the manufacture of formic acid would require the whole of this page to give with efficiency.

AMATEUR.—The mottling to which you refer appears to be due to the especial lighting and extreme sharpness of the texture of the skin. A trifle longer exposure would probably have got rid of it, and would also have given more brilliancy. The chief faults in the picture are due to unsuitable background and accessories.

D.—We will mention your queries to Mr. Blanchard, as, in our experience with the formula, we have not met with the difficulties named. You may remove slight fog or excessive deposit on the shadows, by using with great care, a dilute solution of iodine and cyanide of potassium, one grain or less of each in an ounce of water. Try on a valueless negative first, as great care and quickness in washing, the moment sufficient action has taken place, are necessary.

RECENT SER.—The best strength for using the double sulphate solution depends upon many points. Try some of the formulae which have recently appeared in our columns. The salt is now to be had of all dealers, or may be made by the formula we have once or twice given, which consists in dissolving protosulphate of iron and sulphate of ammonia in their equivalent proportions in water. It may be either kept so, or re-crystallized. 2. A light grey, either of woollen cloth or in distemper colour, is best for vignette backgrounds.

Several correspondents in our next.

Photographs Registered during the Past Week.

- MR. JOHN LAWRENCE, 83, Grafton Street, Dublin,
Photograph of the "Phoenix Eleven."
Photograph of the "University Eleven."
- MR. JAMES RUSSELL, Littlehampton,
Photograph of the Rev. William Knight.
- MR. GEORGE TRAGUE, 90, Oxford Street, Swansea,
Two Photographs of the Rev. John George Gauntlett.
- MR. JOHN HAWKE, 53½, Union Street, Stonehouse, Devon,
Photograph of the Rev. W. H. Parker.
- MR. WILLIAM JOHN JENNINGS, Market Harborough,
Photograph of St. Dionysius Church, Market Harborough.
- MR. WILLIAM S. SHIRRAS, 49, Broad Street, Aberdeen,
Photograph of the Aberdeen Volunteer Review.
- MR. WILLIAM GUTHRIE, 23, Nuns Street, Newcastle-upon-Tyne,
Photograph of Matilda Dunsmore.
Photograph of Emily Cross.
- MESSRS. HILLS SANDERS, 16, Corn Market Street, Oxford,
Photograph.—Royal Commemoration Group; consisting of
H. R. H. the Prince of Wales, H. R. H. the Princess of Wales,
the Countess de Grey, Lord Mount Edgcumbe, Lord Harris,
Earl Granville, General Knollys, Colonel Keppel, the Hon.
Robert Meade, Dr. Liddell, Mrs. Liddell, Miss Rhoda
Liddell.

THE PHOTOGRAPHIC NEWS.

Vol. VII. No. 252. July 3, 1863.

CONTENTS.

	PAGE		PAGE
The Collodion Film Dissolving when Varnished	313	The Preparation of Collodion. By Dr. F. Fuchs	320
Sale of Photographic Poisons	314	Recent Patents	320
Photographic Chemicals	314	The Fulminating Process.....	321
The Philosophy of the Toning Process. By John Spiller, F.C.S.	315	Magic Lantern Slides	322
Mr. Glaisher's and Mr. Spiller's Photometric Experiments. By Charles Heisch, F.S.C.	316	Correspondence—Foreign Science.....	322
Lime Toning Experiments. By V. Blanchard	316	Photographic Notes and Queries	323
A Cheap Glass-House	317	Talk in the Studio	323
Rapid Dry Process.—Further Details. By Thomas Sutton, B.A.	318	To Correspondents	324
		Photographs Registered during the past Week	324

THE COLLODION FILM DISSOLVING WHEN VARNISHED.

ONE of the most annoying troubles which a photographer can encounter is the loss, from any cause, of a fine negative; but his mortification is complete when the destruction is produced by the very means intended to preserve it from injury. A brilliant negative, securing some unusually graceful pose, or charming expression, in a portrait, or a choice of effect of light, with perfectly still foliage in a landscape, is fixed, washed, and dried, without a flaw. The intensity is just right, the shadows quite clean—in short, the negative is perfection. It must be varnished at once with a hard spirit varnish: the plate is warmed, the varnish poured on, when, to the horror of the operator, a transparent spot appears at the point where the varnish was poured on, and “ere a man can say behold,” the image is floating in fragments over the plate.

The misadventure is fortunately not of common occurrence, but most photographers of much experience have occasionally met with it. Dr. Wright and Dr. Diamond both mentioned, at a recent photographic meeting, the mishap as having occurred on their hands, and they both agreed in referring it to a removal of the image only, not the disintegration of the film. They regarded it as due to a peculiarly horny sample of collodion on which the image was quite superficial, not permeating the film properly. Mr. Shadbolt believed it to be due to the entire solution of the collodion film, some samples of pyroxyline being, as was well made known, soluble to some extent in strong alcohol.

Dr. Van Monckhoven, writing on the subject, stated his conviction that both opinions were partially correct. That the removal of the image was due to a partial solubility of the pyroxyline, but that a superficial layer of it only was dissolved leaving the greater portion of the film intact. He bases his conviction upon an opinion which we consider erroneous. He says:—“Many persons imagine that the image formed penetrates the film; but this is not the fact for, upon examining the film at the back of the plate, we perceive that the iodide of silver remains perfectly white. The luminous impression is confined to the surface of the sensitive film, and does not penetrate its substance.” In this view we think the worthy doctor is scarcely accurate. In some instances the image is doubtless superficial, but in others, and these the majority and the most perfect, the image is embedded in the collodion film, all, or the greater portion, of the particles of iodide, bromide, and nitrate of silver which are held in its substance when it leaves the silver bath, going to form the image. To examine by the method to which Dr. Van Monckhoven refers, we have an unfixd plate now before us in which the darkened image of reduced silver is plainly apparant by reflected light on both sides of the plate at the back nearly as plainly as at the front, embedded in a thick cream-coloured film of iodide of silver. Further, if the image were merely superficial, the subjacent layer of sensitive salts remaining

unaffected by light or development, the thickness of the film, would be altogether unimportant, and would have no effect upon the image. It is well known, however, that a collodion with a good body, giving a creamy film in the silver bath, is a most important element in securing intensity in the image. Again, if the image were entirely superficial, and the subjacent layer of collodion and silver salts were inoperative in producing the image, still less could any preliminary coating on the glass plate play any part in its formation. Yet it is well known that a preliminary coating of dilute albumen gives extraordinary vigour and warm tone to the image on plates so prepared before coating them with collodion, and rendering the conviction inevitable, not only that the image is formed right through the film, but that a substratum of a substance capable of combining with silver also aids in forming and modifying the character of the image.

Where the image is formed on the surface only of the collodion film, we regard it as a defect, which may be due to several causes. A collodion, forming a horny repellant film, especially if heavily iodized and excited in a weak silver bath, will give such an image. So completely superficial may the image be in such a case that it may be wiped clean off the collodion, whilst wet, without abrading the film or leaving a trace behind. We recently tried a sample of pyroxyline, and used the collodion, which was heavily salted, a few hours after it was mixed. The image started out vigorously, and developed, to all appearance, quite satisfactorily. But on the application of a heavy stream of water to wash the negative before fixing, portions of the image were removed in patches by the force of the water. At the expiration of a week sufficient change had taken place in the character of the pyroxyline to render it less horny, and a negative sufficiently in the film, instead of on it, was obtained by the same collodion.

We recently met with the mishap, the first time for many years, of the image being destroyed on applying the varnish; but it was manifestly the whole film which was attacked by the alcohol. It broke away and separated into fragments, some of which floated apart. Correctly speaking, the image did not dissolve: the solution took place in the deep transparent shadows, where there was no deposit of silver, and the fragments to which we refer as floating consisted of dense portions of the image formed by the silver deposit. We have one of a series of negatives upon which we then experimented, in which the hands, which were clasped resting against a dark silk dress, were dissolved from the arms, also draped in dark silk, and floated a little distance away and then stopped, giving the effect to the arms in the negative of being about half an inch longer than they were. The negatives in question were taken with an old and somewhat decomposed collodion, the cotton having originally been made at a high temperature. The varnish was made of strong spirit, and what we discovered to be the most fatal cause of all, we made the plate very hot. Having dissolved one film by accident, we proceeded with several more taken with the same collodion, for experiment.

We found it was quite possible to save the same films with care. Even with the same varnish, applied nearly cold, and then warmed just sufficiently to prevent the varnish chilling, the film was not dissolved. The use of a spirit varnish, of much more body, was also found efficient to prevent the film dissolving. It is curious, but, we believe, a fact, that when a strong alcohol holds in solution a large proportion of a gum resin, it is much less active in dissolving other substances upon which it would otherwise act energetically. The use of a varnish made with a less highly rectified spirit was also found efficient, as was also varnishes of which benzole or chloroform was the solvent.

When, therefore, a collodion has been used, the dried film of which shows any tendency to solution when varnished, there are several precautions which may be used. Besides that to which Dr. Van Monckhoven refers of applying first a weak solution of gum arabic, or what may also be used with perhaps greater advantage, dilute albumen, applied before the negative dries, the tendency may be checked by using a spirit varnish of considerable body, and made with alcohol containing a little water,* and using the least heat which will permit the varnish to set without chilling; or by using a benzole or chloroform varnish instead of one in which the solvent is alcohol.

SALE OF PHOTOGRAPHIC POISONS.

The following letter recently appeared in one of the morning papers:—

"Permit me through the medium of your journal to call public attention to the fact, that, whilst chemists generally are so restricted in the sale of poisons, vendors of photographic materials retail indiscriminately one of the most deadly, cyanide of potassium, frequently without warning of its dangerous properties or superscription of any kind on the wrapper. But for the hope that publicity may lead to the exercise of more caution in so important a matter, I would not encroach on your valuable space.—I am, Sir, yours, &c. T. J. B."

We are not aware of the recent occurrence of any mishap which gives especial force to the above letter, or directs peculiar attention to its subject at the present time. Nor, indeed, considering the familiar use of so many deadly agents as are employed in the operating room, do we think that either accidental or wilful misuse of them, to the danger or destruction of human life, has been common or frequent in the history of photography. Notwithstanding all this, however, we fear there is some good ground for the complaint in the above letter. Amongst the chemicals in use so frequent that familiarity has almost bred contempt, are several of the most dangerous and potent poisons in the materia medica. These are vended in large quantities, sometimes without label at all, and often without the warning word "Poison," which should serve as a perpetual caution as to the careless use or exposure of the fatal articles.

This is certainly not wise or desirable. We are not aware of any legislation enactment which controls or directs the mode in which the chemicals in question should be sold or labelled; but the wholesome custom of the retail chemist has established the practice of labelling with extreme care all drugs, and of adding in prominent letters the word "Poison" to all preparations dangerous to life. In regard to some especially dangerous drugs, which have frequently been used in cases of criminal poisoning, the legislation has provided distinct restrictions. A special Act was passed about a dozen years ago to regulate the sale of arsenic, the preamble of which stated that its unrestricted sale had facilitated the commission of crime. Conditions of a very stringent nature were therefore imposed as to its future sale. It was enacted that a complete record, according to a pre-

* A few drops of distilled water may be added to an ounce of varnish, with agitation. It will at first possibly turn turbid, but will clear in a few hours, or a day or two.

scribed form, should be kept in a book, of the quantity sold, the purpose for which it was purchased, the date, and the name, address, and occupation or condition in life of the purchaser. The vendor was to inquire into the truth of the statements made, and to have the signature of the purchaser appended to the entry in the book. If the purchaser were unknown to the dealer, the sale was to be executed in the presence of a witness known to both, and who should sign the entry in the book. These and some other restrictions were enacted, the neglect of any of which renders the offender liable to a penalty of twenty pounds.

Now it is obvious that such regulations, however necessary in the cases for which they are enacted, would be very irksome if extended to other not less dangerous articles; it would be wise, therefore, to avoid the neglect of reasonable precautions. If any serious accident at any time occur which shall, in any degree, be traceable to the neglect to which we refer, it might issue in legislative interference, which would go far beyond insisting on the careful labelling of each chemical with its name, and the word *poison*, wherever the article sold is of a character fatal to human life. We are not anxious to increase trouble or create unnecessary apprehension; but we think the rigid observance of the precaution we suggest is only a reasonable duty.

PHOTOGRAPHIC CHEMICALS:

THEIR MANUFACTURE, ADULTERATION, AND ANALYSIS.

MANGANESE is in many respects a valuable metal, not only to the photographer, but to all engaged in the pursuit of science; its interest being chiefly due to the peculiar affinities which it has for oxygen. The most common source of manganese is the black oxide, known also as the binoxide, or peroxide, MnO_2 . This is found native, and is known by the name of pyrolusite. In the form in which it is usually met in commerce, peroxide of manganese is an intensely black, heavy powder, prepared by grinding up the native variety. Of course it cannot be expected to be a very pure substance, and in fact it is generally found to contain iron alumina, carbonate of lime, as well as sulphate of lime and chlorides; the latter impurity is the only one of much importance, and it should be carefully removed by washing the powdered manganese with water. The chief uses of peroxide of manganese are for the preparation of oxygen and chlorine. When it is heated to dull redness a portion of its contained oxygen is evolved, and sesquioxide of manganese is left behind. If the temperature has been sufficient, between 11 and 12 per cent. of oxygen is given off. If the manganese has been free from chlorides, the oxygen is pretty pure, but otherwise the first portions of gas which come over are liable to be contaminated with chlorine. By heating binoxide of manganese with oil of vitriol, at first one-fourth of its oxygen is evolved, but at a higher heat another fourth comes off, and sulphate of protoxide of manganese is left behind. By this means more oxygen is obtained. In this process it is even more necessary to have the entire absence of chlorides than when the oxygen is prepared by the simple agency of heat, as otherwise the evolution of the whole of the chlorine in the free state is certain to take place. If the presence of chlorides be proved in the manganese, or if it be desired to remove all chance of the oxygen containing chlorine, the gas should be passed through a two-necked washing bottle, containing a strong solution of caustic potash or soda, before collection for use.

Bin oxide of manganese is also of constant use in the laboratory for the preparation of chlorine; for this purpose it is acted on by hydrochloric acid, either by the direct addition of this acid to it, or by making a mixture of common salt and bin oxide of manganese, and then heating this with oil of vitriol. In the first case the reaction is represented by the following equation.

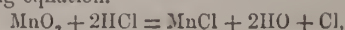

and in the second case by

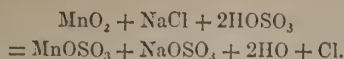

The chlorine is liable to be contaminated with free hydrochloric acid, and should therefore be washed in water, which will hold back the free acid. If required dry, it should then be passed through oil of vitriol. The commercial value of peroxide of manganese depending upon the amount of available oxygen which it possesses, several plans are adopted for ascertaining this quantity; one of the best consists in finely powdering the ore and weighing it. It is then introduced into a small flask apparatus containing sulphuric acid, and an excess of oxalic acid is added. An immediate evolution of carbonic acid is produced, owing to the union of the extra equivalent of oxygen present in the manganese, with the oxalic acid and formation of sulphate of protoxide of manganese.

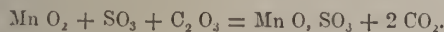

From the weight of carbonic acid given off, the weight of true binoxide of manganese can be readily calculated; 44 parts of the former being equal to 43.57 parts of the latter.

There are frequently met with in nature ores containing hydrated peroxide of manganese. Of these the most noteworthy is known by the name of *wad*. This mineral is not very well defined, and most frequently contains lower oxides of manganese. *Wad* serves to prepare oxygen and chlorine equally well with pyrolusite, but not being so plentiful as the latter, is but seldom employed.

After the peroxide, the next compounds which merit attention are the acids which manganese forms by union with higher proportions of oxygen. When peroxide of manganese is ignited with caustic potash or soda in contact with air, or when fused with an alkaline chlorate or nitrate, more oxygen is absorbed by the manganese forming manganic acid, Mn O_3 , which unites with the alkali present, forming a manganate. Manganate of potash forms an intense bluish green solution, which is permanent when an excess of alkali is present. When an acid is added, or even when manganate of potash is allowed to remain in contact with the atmosphere containing carbonic acid, the manganic acid set at liberty is split up into peroxide of manganese and into another acid, permanganic acid, $\text{Mn}_2 \text{O}_7$, which instantly unites with some of the alkali forming a permanganate of an intense purple-red colour. The manganates are very little known, but by the researches of Mr. Condy the permanganates have been brought before the notice of the public for some time, and their valuable properties are now tolerably well known.

Permanganic acid in aqueous solution may be readily obtained by adding to permanganate of baryta the exact quantity of sulphuric acid necessary to precipitate all the baryta, and then filtering through asbestos or gun-cotton. Sulphate of baryta remains on the filter, and the filtrate consists of permanganic in aqueous solution. It forms a beautifully coloured liquid, which appears dark carmine red by reflected, and dark violet by transmitted, light. When somewhat dilute it is reddish blue, and a still larger addition of water gives it a carmine colour. The acid imparts a distinct red colour to very large quantities of water. It is inodorous, and has at first a sweet and afterwards a bitter, rough taste. It stains the skin brown, but does not redden litmus, as, owing to its powerful oxidizing properties, it destroys the colouring matter of the paper, at the same time turning it brown from deposition of hydrated peroxide of manganese. The aqueous solution slowly decomposes when gently heated or exposed to the light with deposition of peroxide of manganese; a dilute solution is completely decomposed when boiled, but when concentrated it may be boiled for many hours without sensible decomposition. The slight affinity which exists between the metal and the higher atoms of oxygen render this acid one of the most powerful oxidizing agents known. Hydrogen gas passed through it decomposes it rapidly with formation of water: charcoal is

rapidly attacked with production of carbonic acid; phosphorus and sulphur are raised by it to the state of acids; most metals are oxidized, and most metallic oxides are raised to a higher state of oxidation. Where possible, alcohol, ether, sugar, gum, woody fibre, paper, camphor, turpentine, vegetable oil, stearic acid, morphia, gelatine, albumen, infusion of galls, madder, and the multifarious collection of substances classed by photographers under the name of organic matter, are all burnt up by permanganic acid, and rendered inactive, generally being resolved into the ultimate products, carbonic acid and water. Other substances which would not at first sight be supposed to possess any special action upon the acid, likewise decompose it; for instance, finely divided platinum put into an aqueous solution of permanganic acid, produces a brisk disengagement of oxygen. Perhaps the most curious of the decompositions of this kind, is that which takes place between permanganic acid and binoxide of hydrogen. In this case, we mix together, perhaps, the two most powerful oxidizing agents known, and the result is very remarkable, all the excess of oxygen at once goes off with brisk effervescence, the permanganic acid being reduced to the state of brown oxide, and the binoxide of hydrogen becoming simple water.

THE PHILOSOPHY OF THE TONING PROCESS.

BY JOHN SPILLER, F.C.S.

THE chemical action exerted by the compounds of gold when employed in the process of toning photographic proofs upon paper, has engaged much attention, and been repeatedly made the subject of experiment, on the part of analytical chemists, both in this country and abroad; but, notwithstanding the numerous collection of facts already placed on record, there yet appears ample scope for diversity of opinion regarding the nature of these several reactions. In the sixth volume of this journal, at page 267, will be found a statement on this subject by Dr. Schnauss, who inclines to the opinion that the toning process is, under ordinary circumstances, the means of effecting the entire removal of the reduced silver from the print by the substitution of gold; or, at least, that this is the ultimate result when the fixing agent has fully exerted its solvent action upon the chloride of silver left at this stage on the prepared surface. Later, at page 470 of the same volume, I had the honour of communicating a series of analytical results "*On the Expenditure of Silver and Gold in Photographic Operations,*" by which I was led to believe that this interchange of metals was not usually so complete as had been represented, inasmuch as there was always a larger proportion of silver than of gold contained in the photographs examined by me; and it was further stated that even in the case of bluish-black, over-toned proofs upon albumenized paper, this was the invariable result. In consequence of my assertions, and similar expressions of opinion by Dr. Van Monckhoven and M. Girard, at the French Photographic Society, Dr. Schnauss was induced to repeat his experiments, the full particulars of which, translated from the *Moniteur de la Photographie*, again appeared (Vol. VII. p. 243) in the PHOTOGRAPHIC NEWS. On reading this second article by Dr. Schnauss it became at once apparent that the conditions of experiment were somewhat abnormal, the sensitized papers having been exposed to light until their surfaces were completely bronzed, and then, after washing, immersed for one hour in a dilute solution of chloride of gold, fixed with hyposulphite of soda, washed with dilute ammonia, and lastly with water. Plain salted paper, and another sample prepared with arrowroot, were made use of by Dr. Schnauss; and the evidence of Professor Reichard, of the University of Jena, was adduced in confirmation of the truth of these analytical results. They did not find any appreciable trace of silver on the paper toned with gold. But it may now be asked whether these conditions at all represent the manipulation generally followed by practical photographers? Is it usual to occupy

an hour in the toning process; or, even desirable, to force the print to take up the maximum quantity of gold? Provided that the desired tint of colour is ensured, it matters not how superficial be the coating of reduced gold, and it has been demonstrated by my former experiments that from two to three parts by weight of silver may remain in mechanical union with one part of gold with very satisfactory results as regards the colour of the proof; whilst, on the other hand, it can safely be asserted that gold by itself does not give so agreeable an effect.

There was one point, however, which I felt it was necessary to clear up before pronouncing generally that photographs made upon the present system must of necessity contain silver. This reservation arises from the circumstance of my having employed in former experiments the albumenized paper so commonly used in this country, and which, by my own showing, is apt to retain silver in an insoluble form throughout the process, and quite independently of the action of sunlight. Wishing to exclude this source of error, which becomes important only when a principle is at stake, I have recently taken some prints upon plain salted, *Canson* paper, toning them as before to a full stage by the use of a bath of chloride of gold made alkaline with bicarbonate of soda, and fixing them with hyposulphite of soda. After thorough washing the pure whites of these proofs were found, on testing with sulphide of ammonium, to be absolutely free from silver. A few of these prints were then burnt in separate parcels, the ashes carefully collected and boiled with dilute nitric acid, when, on testing the clear solutions with hydrochloric acid silver was found in every instance. The products were not weighed, but, estimating roughly their amount in comparison with the gold afterwards obtained from the insoluble residues, my judgment would lead me to say that the silver exceeded the gold. There is very little doubt but that these same prints, already somewhat over-toned, would have lost in silver and gained in gold by longer immersion in the toning bath, but the result would not then have agreed with practice; it would merely have furnished evidence of a fact long since ascertained, viz., that metallic silver is capable of withdrawing the chlorine from tetrachloride of gold, reducing the latter to the state of metal, and becoming itself converted into chloride. Dr. Schnauss distinctly states that "it is only pure metallic silver that can accomplish this, and not sub-chloride of silver." From my own experience I cannot controvert this statement, for I have never yet succeeded in preparing the so-called "sub-chloride of silver," and should be well pleased, if it exist, in having an opportunity of investigating its properties.

In conclusion, it may be remarked that this subject was discussed, on the 11th May last, by the American Photographic Society;* that Dr. Van Monckhoven† has already replied to some of the views lately advocated by Dr. Schnauss; and that the gentleman last named did not succeed in producing photographs in pure gold by the employment of a toning bath of *sel d'or*, or of any compound of that metal with hyposulphite of soda.

Chemical Department, Royal Arsenal, Woolwich.

MR. GLAISHER'S AND MR. SPILLER'S PHOTOMETRIC EXPERIMENTS.

BY CHARLES HEISCH, F.S.C.

Will you allow me through your valuable journal to make a few remarks on the subject of Mr. Glaisher's photometric observations, and the admirable note thereon by my friend Mr. Spiller. The result of the experiments detailed by him show what is familiar to all those using Marion's preservative cases, that perfectly dry photographic paper is not easily affected by light, but they do not show whether a dry

atmosphere, apart from its depriving the paper of moisture, is unfavourable to photographic action. The following facts, bearing on this point, may not be uninteresting to some of your readers.

In August, 1854 (the precise date I am ashamed to say I forget), there was one day memorable to all photographers. The sky was cloudless, the atmosphere particularly clear, the sun shining brightly, temperature 85° in the shade, and the air so dry that it was next to impossible to find a dew-point with a Daniel's hygrometer. Notwithstanding the brightness of the light, photography was simply impossible. No length of exposure would blacken paper under a negative, and what is far more remarkable, wet collodion plates which the day after gave with the same lens and under similar circumstances, in the same place, good negatives in 5 seconds, on this day gave only half exposed positives in 1.5 minutes, and negatives could not be obtained. The question of printing might, of course, be due to the dryness of the paper, but the collodion film was wet, so that it would seem as if there were actually less chemical light present than under ordinary circumstances. I would suggest that daguerreotype plates, the surface of which is more perfectly independent of hygroscopic moisture than any other photographic surface we are acquainted with, offer the best means of investigating this interesting question. If a large plate were iodized and then cut up into small ones, uniform surfaces would be obtained. Suppose now a small camera screwed firm on a board with an object (say an engraving) fixed firmly at a given distance from it, and perfectly focussed. One of the small plates might be exposed for a certain time before the ascent, the others for the same time at different altitudes; if thought necessary, equality of temperature might be obtained for each plate by placing behind it in the slide an equal sized plate of copper heated to about 80°. On the return to earth all the plates could be mercurialized together, so as to insure uniformity in this respect. If any great difference were observable in the results it could hardly be due to any drying of the photographic surface, though the dryness of the atmosphere might still be the cause, but in some yet unexplained manner. I should have mentioned that on the day in August 1854, before spoken of, the observations I made were at Blackheath, but my friend, Mr. G. Busk, arrived at precisely similar results on the same day at Tenby.

I cannot conclude without remarking that I believe photographers might, by a few simple observations on the state of the atmosphere while they are at work, arrive at many results valuable not only to themselves, but to meteorologists. Some years since I proposed to the members of the Blackheath Photographic Society, to carry out such a system of observations, and drew up forms on which they could be easily registered, but, unfortunately, though the forms were taken, they were never filled up, so the project fell to the ground, much to my regret. A little combined action of this sort would be a work well worthy of a society, and would entail but a small amount of trouble.

Middlesex Hospital, June 24, 1863.

LIME TONING EXPERIMENTS.

BY V. BLANCHARD.

It will be generally admitted that whilst we have had a great many theories more or less plausible on the alkaline toning process, they have none of them produced that one thing desired by all photographers, viz., a method of producing uniform results, including a panacea which would secure for them some protection against their deadly foe—*mealiness*.

It affords me, therefore, much pleasure to be able to confirm the statements made in describing the method adopted by Mr. Hughes in producing the very beautiful tone I have noticed in his pictures. I have at different times made many experiments with lime toning, but have never been able to produce anything with uniformity, excepting failure.

* *vide* PHOTOGRAPHIC NEWS, Vol. VII. p. 257.

† *Ibid.*, Vol. VII. p. 271.

Some few weeks ago, however, I undertook some experiments which were more successful. I neutralized the gold with carbonate of lime, employing hot water to hasten the decomposition, and then added hydrochloric acid at the rate of about one drop to the grain of gold. A print introduced into the bath was found to tone rapidly, but it bleached at the same rate, and was therefore useless. The introduction, however, of a drop of ammonia stopped this reduction. The prints toned in the bath were black in tone, and were perfectly free from mealiness. I used a bath so prepared for a week or two, for the tones were very satisfactory; but I found frequently that the bath would indulge in fits of sulkiness, and refuse to work at all. This was, doubtless, due to the action of the ammonia, the whole of the free chlorine being neutralized, and chloride of ammonium formed. Doubtless the whole of the uncertainty of the toning process turns upon the difficulty of securing the exact amount of free chlorine necessary at the moment of toning, with anything like regularity.

I also neutralized the gold by various methods; first, trying carbonate of soda; then, carbonate of lime; and, lastly, carbonate of ammonia, but I added to each bath the chloride of lime at the same time; and consequently, when I tried them I found them no better than the others. On the publication, however, of Mr. Hughes's method I saw that the gold was first neutralized, and then the chloride of lime was afterwards added. I, therefore, repeated my experiments, following the plan there suggested, and met with success so complete that I feel it a duty to record it for the benefit of others. The plan now adopted by me after repeated experiments is as follows:—3 ozs. of chloride of gold solution, containing 1 grain to the oz. of water, is poured into an earthen vessel, 9 grains of carbonate soda is now added. It is well stirred until the soda is deposited, and then hot water from the kitchen boiler is poured in, making the whole quantity up to 10 ozs. It will be found, on stirring well, that the whole of the yellow colour will disappear, leaving the solution colourless. It must be now allowed to cool down until the solution is milk-warm, and then 9 grains of chloride of lime must be added, *but not before*. *The whole success of this method of toning depends upon attention to this matter.*

The solution must now be well stirred, and allowed to settle for five minutes, and it is then ready for use. It will be found that the prints, when immersed in the bath thus prepared, tone steadily, but not rapidly, and gradually assume a blue-black of great intensity, and with very little loss of vigour by bleaching. At this point the toning action should be stopped, and the print immersed in water, and afterwards fixed in hypo in the usual way. The tone of the picture when dry and finished will be a clear neutral grey in the deeper half-tones, an intense black in the shadows, and a delicate warm colour in the face, and all the lighter portions of the picture not absolutely white.

In my hands the bath made with carbonate of soda, instead of lime, is most uniform in action, whilst in the finished pictures I can see no difference between them. I must admit that theoretically the carbonate of lime appears best for being insoluble, or nearly so, in water, only as much as is necessary to neutralize the free hydrochloric acid in the gold can be taken up, the rest falling to the bottom, and the solution is consequently only neutral when the chloride of lime is added; but in practice I have found that in using the carbonate of soda a grain or two more or less made no difference, and the solution is brighter, and free from sediment, and it takes a considerable time for all the carbonate of lime to settle to the bottom, and to filter the solution would only increase the trouble without any absolute gain.

It is much to be regretted that the chloride of lime is such an uncertain compound, for it is almost impossible to get two samples alike. It is extremely doubtful if the lime play any part in the production of the black tones, and it is more probable that the peculiar action is due to the loose

manner in which the chlorine is combined with the alkali, and its readiness to depart in search of fresh quarters. I was mentioning this matter to Mr. Crookes, and he suggested the trial of hypochlorite of soda as being a more definite compound, and of the same constitution as chloride of lime.

If this salt should prove successful much would be gained, for it frequently happens that one sample of chloride of lime contains twice as much chlorine as another, and whilst with too little chlorine present the toning will not go on well, and the desired colour cannot be obtained, too much will make itself evident by its desire to restore the paper to its original whiteness.

One important fact must not be lost sight of in adopting this process, that nearly double the quantity of gold is requisite. Of course more gold is needed to tone a picture black by the alkaline method than to tone it brown; but independent of this, there appears to be a more energetic deposit, for it will be found that the bath will work with great vigour for a given time and then stop all at once, and no lengthened immersion will produce the desired effect upon the print.

A CHEAP GLASS-HOUSE.

At a recent meeting of the North London Photographic Association, Mr. Bockett, a clever and ingenious amateur photographer, briefly described a convenient glass-house which he had erected himself upon especially economical principles. We took an early opportunity of calling upon Mr. Bockett, who had courteously invited us to inspect his erection. We found the studio small, but convenient, the folding doors materially increasing the range of distance to which the camera might be removed from the sitter. It was characterised throughout by ingenious contrivance. For instance, a pedestal which was frequently useful as a background accessory was also a cupboard into which was packed a great many of the smaller items of the studio, not desirable to be left about, during the intervals between an amateur's operating. We saw some very good card negatives, which Mr. Bockett had just taken with a very few seconds exposure, which illustrated the facilities for lighting the model, which the room rendered available. We have been favoured with a detailed description of the studio and its mode of construction, together with a schedule of the items of cost, amounting in all to the small sum of £7 ls. 4d. We now append Mr. Bockett's communication.

DEAR SIR,—In accordance with your request I beg to hand you full particulars of my (or rather I should call it substitute for) glass-house. At the foot hereof will be found the quantities and cost of the material, but prior to going into that I will inform you how the matter got about. For five years I managed, with one contrivance and the other, to take my pictures out of doors with simply a projecting screen over the head of the sitter, to moderate the shadows cast by direct light from above; but, as from doing them gratis I found persons were willing to pay (and amateur photography is not all profit); I also found that to produce pictures that would give satisfaction, required some additional outlay as well, as I would add improvement in manipulation.

Now the chief end in view was to make some erection that could be easily removed, not take up too much space, be watertight, and give a range of, say, twenty feet. The first was obtained by having the place built up of sashes, there being four in the roof (which stands due east and west); two in the north side, which is close to a low wall, so that none are required below them, and one large sash on the south side; the remainder of the house being composed, for the most part, of feather-edge boarding; the skeleton to which all the foregoing is attached, being simple 2×2 inch quartering; the joints are covered with canvas, and painted, which has, hitherto, as to keeping out the wet, answered very well. To enable me to get my range, at the eastern side (in which two small windows are placed), I have two folding doors, simply made of beaded boards nailed to some cross pieces, which, opening outwards, give me any distance I may require, and effectually protect the sitter,

accessories, &c., from the weather. Next to the larger sash before alluded to, and near to the folding doors, is another door, in order that access may be obtained to the interior without disturbing the camera or any thing else that may, for the time being, occupy the space between the folding doors.

Some battens, laid edgewise upon the ground, receive the flooring planks, which would have been all the better if closer together and attached at each end to the bottom frame of the skeleton. The folding doors bolt top and bottom, from the inside, and the side door is locked from without, so that all within is properly secured. In the figures below no credit is taken for the labour expended by myself, nor for the contrivance, which simply arose from something of the kind becoming a necessity, and that, being only of limited means, I was called upon to invent something that would really answer my purpose. Constructed as this is, the sashes for the most part being screwed to the ridge piece and sides of the top frame, I believe any one could take it all to pieces in an hour. If the above is of any service to your readers I humbly place it at your disposal.



The shaded part represents wood, mostly feather-edge.

To equalize the light from the south the whole of the large sash is covered with thin calico blinds, and the same with the roof, except that the portion over the head of the sitter, which is covered with paper, the same as used by chemists, and which is known by the name of demy (although I believe the latter only denotes the size).

Wood.	£	s.	d.
13 feather-edge boards 16 feet long ...	0	14	8
2 boards $\frac{3}{4}$ thick, 7 feet long, 7 inches wide ...	0	2	3
12 beaded boards 6 feet long, $\frac{1}{2}$ inch thick, 7 wide ...	0	6	0
2 ten-foot battens, 2 by 1 ...	0	1	3
1 " " 3 by 1 ...	0	0	9
172 feet of quartering, 2 by 2 ...	0	15	3
1 board 10 feet long, 1 inch thick, 11 wide ...	0	1	11
12 boards 7 feet long, $\frac{3}{4}$ inch thick, 9 wide ...	0	10	0
Odd stuff (beading, &c.) ...	0	8	5
	£3	0	6

Labour.	£	s.	d.
Paid for making sashes ...	£1	9	7
" 3 days, 8 o'clock to 6 ...	0	11	0
	2	0	7
Nails, bolts, hinges, screws ...	0	7	8
Paint ...	0	6	8
Glass and putty (about 150 feet, and $\frac{1}{2}$ cwt. of putty) ...	1	3	3
Lock and key ...	0	0	8
8 yards of calico lining for blinds ...	0	2	0
Total ...	£7	1	4

—Believe me, yours, very truly,

JOHN BOCKETT.

RAPID DRY PROCESS.—FURTHER DETAILS.

BY THOMAS SUTTON, B.A.

In a recent number of the *Photographic Notes* Mr. Sutton gives some further particulars regarding his rapid dry process. He says:—

The process described has been tried by several persons, and with different results. M. Liesegang, of Elberfeld, states, in the German photographic periodical of which he is editor, that he has obtained very fine clear negatives by the process, but requiring an exposure double of that which was necessary with the same collodion and bath, and wet plates. Major Russell stated in the autumn, that he had tried gum some years ago, and given it up because it produced dirty negatives, covered with red fog and blisters, and in which, if you gave sufficient exposure to the foreground, the sky and high lights, instead of stopping short at their outline, ran over it into the other parts of the picture. He stated also, that he had found no advantage in increasing the dose of bromide beyond a certain point, but on the contrary, that the sensitiveness was impaired by so doing. And with respect to sensitiveness, he expressed his belief that his own tannin plates were nearly as sensitive as those prepared with gum. We could not understand at the time the force of his objections, not having experienced ourselves any of the troubles referred to, but we have since discovered that the red fog, and smearing of the high lights, is due to the use of an old worn-out nitrate bath overcharged with iodide of silver, and other foreign substances. But lately the Major's views have undergone some modification, for we find him now recommending bromide alone in the collodion, and mixing gum with his tannin, for some unexplained reason, thereby contradicting in his present practice his former confidently-expressed opinions. We have also received evidence on the merits of our process, of a more favourable character. Captain Hughes, of Everton Valley, Liverpool, has lately written us a note, in which he says, "In your letter which accompanied the panoramic print you recommend me to try your rapid dry process. Your advice was unnecessary. I had been working at it previously. I commenced when I secured your 'Collodion Processes Wet and Dry,' and have been very successful. I have taken perfectly satisfactory cartes in my glass room in 20 seconds. I have had no time for printing lately, but will send you specimens in a few days." Mr. Rowland, of Norwood, also states that he has taken good instantaneous pictures upon dry plates prepared by our process,—and that he has tried mixing the gum with tannin. He adds, "I find that the plates work better with plain gum. I do not like the mixture of gum and tannin, as it gives frequent stains. I do not think anybody could want sharper pictures than the gum gives." And so on. Thus the evidence on the merits of our process, although conflicting, is on the whole favourable, and we hope that those who may have been deterred from trying it in consequence of Major Russell's condemnation, may now be induced to take the matter into their own hands and judge for themselves. The Major's recent experience with gum and tannin seems to confirm that of Mr. Rowland, and if our advice is worth anything, we would suggest him to try gum alone, along with his good old-fashioned bromo-iodized collodion, in which he unconsciously recommends the mixture of bromine and iodine in equivalent proportions,—and above all, a fresh nitrate bath made with the recrystallized salt, and in decent working order. He will then obtain plates precisely resembling in appearance the rapid ones of Dr. Hill Norris; and if he exposes them side by side with the doctor's, he will find no great difference either in the sensitiveness of the plates or the quality of the negatives produced.

These remarks are introductory to an account of some minor improvements which we have made in our process, and some speculations on dry plates generally.

When a preserved plate, which is completely dry in some parts but damp in others, is exposed in the camera, the damp part is much less sensitive than the dry part, and gives a poor, thin image. This is one fact, and it proves that a preserved plate acquires sensitiveness on drying. Again, whether a dry plate is prepared with iodized or bromo-iodized collodion it is more sensitive when it is not thoroughly washed than when gallons of water are poured

over it. This proves that a trace of free nitrate is always an element of sensitiveness; and thus, when the most exalted sensitiveness is required, the plate should not be excessively washed. We are now of opinion that the presence of bromide of silver in the film is not entirely a compensation for the removal of the free nitrate. You may wash a bromo-iodized film tolerably in two or three waters, and find it nearly as sensitive as ordinary wet collodion, but the washing must not be pushed too far if you wish it to be quite equal in sensitiveness to good wet collodion. We have adopted this opinion with reluctance, but it seems inevitable, and the facts cannot be explained without it. If they could, why is a well-washed bromo-iodized plate less sensitive than a less thoroughly washed one? It seems nearly certain that the iodized or bromo-iodized collodion film requires a certain quantity of nitrate of silver to be in close contact with the iodide or bromo-iodide of silver, in order to produce the greatest possible sensitiveness. In the ordinary wet process the silver solution from the bath, which clings to the film, is sufficient. In the dry process, the small trace of nitrate of silver which is left in the film after washing the plate, is not sufficient whilst the plate remains wet; but as it becomes dry, and the water evaporates, this small trace of nitrate of silver becomes concentrated in the neighbourhood of the iodide and bromide, and if that trace in its concentrated state is sufficient, the plate recovers its original sensitiveness, and is not in this respect inferior to the best wet collodion plate. In the case of the wet plate, that portion of the nitrate of silver in the 30-gr. solution that clings to the film which is in actual contact with the bromo-iodide of silver, is enough to confer exalted sensitiveness, while the remainder is necessary to the development. In the case of the dry plate, that portion of the dry nitrate of silver which has been obtained by the evaporation of the weak silver solution which remains upon a washed film is sufficient, by its contact with the bromo-iodide of silver, to confer the same exalted sensitiveness; but there is no surplus for the development.

We are thus able to account for the discrepancies which occur in the experiments of various persons who have recorded their results. No definite or invariable system of washing the plate has been adopted, and that is why some have obtained greater sensitiveness than others with our rapid dry process. And to this may be added the fact, that the great importance of thoroughly drying the plates before their exposure has not been fully acted on, or acknowledged. We now wish those who try our process to proceed as follows:—

The collodion is to be bromo-iodized, containing iodide of cadmium, or bromide of cadmium in the proportion of ten to two. The quantity of these salts used to the ounce of collodion must depend upon the amount of creaminess of film which is desired; and the same consideration must determine the quantity of pyroxylins which is to be contained in the collodion. 6 grains of pyroxylins, 6 grains of iodide of cadmium, and 4 grains of bromide of cadmium give a very creamy film. The collodion which Mr. Bailey manufactures for our rapid dry process does not contain so much iodide and bromide as this; and gives a pale but a very even and delicate film, and is as sensitive as the other, or very nearly so, and gives a softer negative.

The nitrate bath need not be stronger than 35 grains to the ounce, and if you wish for red negatives, which are the easiest and best, add a little acetic acid to it, say six drops to the ounce of solution.

After exciting the plate immerse it in a bath of distilled water, and then in another of rain water, quite clean. It is immaterial how long it remains in the water, but the longer the better, because it is important to remove all the uncombined bromide of cadmium, as well as the nitrate of cadmium, from the film.

The plate must now be placed in a bath of distilled water, containing 1 grain of nitrate of silver to the ounce, or thereabouts,—as well as an equal quantity (one drop) of acetic acid.

After remaining a minute or so in this bath the preservative solution is to be poured over it. The object of the weak bath of aceto-nitrate is to impregnate the film with a definite quantity of nitrate of silver; that quantity being, of course, exceedingly small and the most imaginable trace.

The preservative solution is composed of gum arabic 20 grains, dissolved in water, 1 ounce. A little of it must be poured over the plate and allowed to flow backwards and forwards several times. Then, without pouring it off, put the plate upon a horizontal support, and let the gum soak well into the film for a quarter of an hour before you set it up to dry. This will reduce the tendency to blistering &c., because the gum will soak into the film, and make it stick better to the glass. A small quantity of sugar may be added to the gum, and this renders it less skinny when dry, and reduces the tendency to blistering. By either of these methods a substratum of albumen or india-rubber becomes less necessary. The gum solution should not be stale and decomposed.

The plate must be allowed to dry spontaneously, but before putting it into the slide, it is important to dry it again thoroughly by holding it before a hot flat iron. The heat does not cause the plate to fog, although nitrate of silver is present; this fact is important to have established. Unless the plates are thus dried by heat on the morning before their exposure the result will be uncertain, and the least dampness in the film will be fatal to obtaining a good negative.

The exposure may be the same as for wet collodion plates—that is about 15 seconds to an ordinary well-lighted view, with a stereoscopic view lens 5½-inches focus, and ½-inch stop. With the ½-inch stop instantaneous views of clouds and waves may be got in a good light.

The development is effected with cold pyrogallic acid and silver, exactly as recommended by Dr. Hill Norris, without any ammonia, or hot water, which would only end in grief and vexation.

It is always surprising to us that persons are so ready to run after all sorts of queer novelties in the development, and at the same time ignore the fact that Dr. Hill Norris' rapid dry plates have never been surpassed in sensitiveness, and are at the same time developed in the usual simple way. How unreasonable it seems in any investigation to go on groping in the dark after novelties, and at the same time ignore the fact that the very thing of which you are in search has already been done in a known simple way. Is it not more reasonable to avail oneself of what has been already done by the labours of others, than to grope in the dark and try to do the same thing in a different way? If Dr. Norris has proved, as he has done, that rapid dry plates can be satisfactorily developed in the usual way with cold pyrogallic acid and silver, why bother about the ammonia, the hot water, &c.? Why not accept his method of development, and try to discover how he prepares his plates? That is exactly what we have done. We have tested his preservative, and find it to be gum arabic. We have tested his plate and find it acid, and also that it contains a trace of free nitrate. It has, moreover, the property of becoming more creamy and opaque when wetted with the finger, exactly as our plates have, and its colour is the same, as well as its behaviour when exposed to light, and when rubbed about upon the glass. Dr. Hill Norris has been our guide in the search for a rapid dry process. We have endeavoured to find out his secret, and to all appearance have succeeded. Those who wish to give our process a fair trial must follow our directions implicitly, and compare their plates, as well as their negatives, with the Doctor's plates, and the negatives obtained upon them under the same circumstances. Let them not try impatiently too many things, and go running after fresh novelties like so many children, experimenting with hot water on day, ammonia the next gum and tearin the next, and trouble with wet iodide the next. All this is so much groping in the dark. Let them rather accept the demonstrated fact of

what Dr. Hill Norris has actually done, and endeavour to work up to the same result by the aid of such light as our experiments have afforded, and such reasons as we are able to give for every stage of the process which we recommend. If the Doctor has really accomplished all that we say, and if our process yields plates so exactly like his in all essential points, as we assert that they do, then surely the best advice that anyone can offer on this subject is to try the process which we recommend before any other.

With respect to the keeping properties of rapid dry plates, the evidence which we have collected during the last few months is not such as to enable us to recommend them to be prepared many days in advance. We would not, on any important occasion, willingly use any dry plate which had been prepared longer than on the previous day, or which we could not develop on the day on which it was exposed. There is, according to our experience, great uncertainty in the use of any dry plates which have been long prepared. Exceptions occur, of course, but we believe our statement to be the rule. It is a deplorable pity that it should be so, but so it is, and the fact accounts for the very small number of pictures from dry plates which are seen in the Photographic Exhibitions. A week or two for slow plates, and a day or two for rapid ones seem to be the extreme limits of certainty, if the plain truth must be told. You may get a negative upon a dry plate a year old, but seldom a perfect one.

THE PREPARATION OF COLLODION.

BY DR. F. FUCHS.*

PERHAPS for no article used in photography does there exist such a variety of formulas, and each one looks for the cause of failure in something else. The following is in my hands always free from failure. The problem of the preparation is simply solved, as will be evident from the formula. For several years in succession, and when operating with two pounds, I have never spoiled the lot nor have had any mishap with it. I took a large vessel and weighed in it 40 pounds of English commercial sulphuric acid, to this I added 18 pounds of pulverized English crude saltpetre, and stirred the mixture with a wooden spatula for ten minutes or so; to this mixture I now added quickly 2 pounds of cotton in light tufts as large as the first, whilst an assistant brought them in contact with the fluid. The mixture is sufficiently thin to allow the cotton to be easily pressed down with a spatula. I let the cotton remain in the mixture until a small piece, after washing with water, pressing, soaking in alcohol, and again pressing, was easily and completely dissolved in two parts of ether and one of alcohol. Until this takes place the cotton is not ready to take out.

When it has reached to this degree of solubility, it is taken out with the spatula, immersed in a large tub of water, and thoroughly washed. It is then taken out in one mass and pressed between folds of linen; after this it is put into a vessel, covered with alcohol, and allowed to remain in this condition for 24 hours. On the following day the deep yellow-coloured alcohol is poured off and totally removed by pressure. Whilst the cotton is still moist, for every single part add two parts of alcohol, and then from 15 to 20 drops of concentrated ether. By this means a colourless, excellent collodion is obtained without failure.

I used the best cleansed cotton, such as is met with in wadding factories, and found it in a great measure yellow, a colour which was afterwards communicated to the collodion. By the above method the yellow colour was removed.

Treating cotton with soda is unnecessary. Ordinary English sulphuric acid is sufficiently strong, and English saltpetre is good enough for the purpose. The latter is used in quantity less than any other known formula, and the great superabundance of sulphuric acid renders the mixture

very fluid, and allows a greater quantity of cotton to be immersed without being detrimental to its quality. By making use of a wooden spatula, which simply assumes a yellow colour, we avoid the risk of breaking a glass rod or the vessel. It is, besides, easier to work with a wooden than a glass rod. Every other formula indicates exactly the time during which the cotton has to remain in the mixture. This depends in a great measure on the temperature and the strength of the cotton fibres. In summer ten minutes is sufficient time for the reciprocal action of the saltpetre and the sulphuric acid, before the cotton is immersed. In winter the vessel containing the mixture must be placed immediately in warm water, before the cotton is introduced, otherwise the fluid, by the formation of bisulphate of potassa in the cold, will become too thick, and the given quantity of cotton cannot be immersed. If abundance of red fumes arise, and these cannot be obviated by pressing the cotton beneath the surface of the mixture, a small quantity of sulphuric acid may be added without any injurious effect upon the product, on which the fumes will immediately cease.

The transition of soluble cotton into insoluble is not quick, and there is sufficient time to make the requisite test. As soon as the cotton has attained its solubility, it is taken out of the vessel, and the acid is well expressed before the cotton is washed. The fluid that remains can be used over again very well in large quantities, when prepared with nitric acid. The cotton must be thoroughly freed from all trace of acidity, which is recognised by the taste and by treatment with litmus paper.

Good pyroxyline, when being washed, feels soft; whilst insoluble pyroxyline, when separated in a moist state, cracks in the fingers and is often corroded. I allow the washed and pressed pyroxyline to remain over night in alcohol, which totally removes the yellow colouring matter, by which proceeding the collodion becomes colourless. The residual alcohol can be used for a lamp. I dissolve the cotton while moist, in order to spare the trouble of separating the tufts and drying. Alcohol 90 per cent. is sufficiently strong, as also concentrated ether of the specific gravity of 0.73.

Recent Patents.

ORNAMENTAL PHOTOGRAPHIC BORDERS.

THIS invention, which received provisional protection only, was a communication from Monsieur Henri Lissagaray, of Paris.

The invention is thus described:—

These improvements relate to the ornamentation of photographic works, and chiefly to the production of backgrounds, borderings, and such like aids to the art of photographing objects. For these purposes I produce the design required by employing a sheet of glass or other equivalent transparent substance, upon which, by galvanic agency, I deposit first a coat of gold or other metal suited for the purpose, and next a coat of platina or other equally suitable metallic surface. I then engrave, by means of a stile or point, the required ornamental design, so that the light may pass through the lines so marked, engraved, or cut into or through the metallic surface. An open space may be left in the centre or other part or parts of the plate prepared as described, so that a portrait or portraits, or other subject or subjects intended to be reproduced may be introduced behind or before such space, or otherwise in combination with such engraved plate.

This process, when used for ornamenting photographic proofs, is employed by means of double stereotype plates of glass or other equivalent transparent substance prepared as described, and used together by superposition or in succession. The effect may be varied by the variations in the depth as well as the width of the lines engraved or etched upon, or cut through the metallic coating of the transparent ground, and in accordance also with the intensity of the light employed, and compound figures and effects can be produced by the intersection of more than one prepared plate used in combination with any other.

* *Zeitschrift für Fotografie und Stereoscopie.*

APPARATUS FOR VIEWING PHOTOGRAPHIC PICTURES.

This invention, known as the Alethoscope, by J. Ponti, received provisional protection only.

It consists in constructing an apparatus for viewing photographic pictures, resembling generally in form that of a "stereoscope," but of considerably larger dimensions, and provided with only one large magnifying lens, and only one representation of the picture (which is also of considerably larger dimensions than those employed in "stereoscopes"), the object of the invention being to present readily to both eyes of the observer, without the inconvenience of looking through two separate lenses, a representation of the picture magnified to such an extent, and at the same time having the stereoscopic effect sufficiently to impart to the same the appearance of the object itself in its natural size. The lens of this apparatus is, by preference, made of such a size as to take in conveniently the sight from both eyes of a person, and a shade surrounding the lens is made to project from the same towards the observer, to prevent the eyes taking in any other rays of light than those passing through the lens; this is also so arranged with adjusting screws, that it can be brought nearer to or moved farther from the eyes, according as the difference of sight requires it.

This apparatus is arranged in a horizontal position on a suitable stand, the picture being in a vertical position, and the end of the apparatus where the pictures are inserted being, by preference, made of an oblong form, provision being made for causing it to revolve round a horizontal axis to such an extent, that in one position the larger dimensions of the picture is horizontal, whilst in the other direction it is vertical, so as to suit pictures of different proportions. The apparatus is arranged for viewing either transparent pictures or pictures requiring a reflected light, for which purpose it is constructed in the following manner:—A portion of the top and side of the apparatus, near the end where the pictures are inserted, are made to open on hinges, and are provided on their inner surface with reflecting mirrors in such a manner as to reflect the light (which may be either artificial or natural, and is, by preference, situated behind the end surface of the apparatus), more or less on to the picture, according as they are adjusted in position. The light is then reflected from the picture through the lens to the eye of the observer. For transparent pictures the two before-mentioned reflectors are closed, and the end opaque surface of the apparatus (which is also provided with hinges) is let down, so that the light passes through the picture. The frame for holding the pictures at the end of the apparatus is, by preference, made curved in such a manner as to cause the picture to be slightly concave when inserted, to suit the form of the lens. In order to prevent the bright light (particularly when it is artificial and situated at the back of the apparatus) from blinding the eyes when one picture is removed for the purpose of inserting another, a more or less opaque flap is provided close behind the lens, which, by means of an external lever, is instantaneously raised in front of the lens when the pictures are being changed.

Another part of this invention consists in preparing photographic pictures to be employed in this apparatus in such a manner that they shall be capable of representing, consecutively, both a day and night appearance of the object. For this purpose the photographic picture is made on paper, or other suitable material, that will both reflect the light and yet be transparent to a certain extent, and is provided at the back with a sheet of transparent paper, or other suitable material, that is coloured with transparent tints representing the effect of night, moonlight, or artificial light, in a manner corresponding to the objects on the picture. By this arrangement, if such pictures are inserted in the before-described apparatus, the back of the same being closed and the two reflectors opened, the light will be reflected on to, and from, the surface of the picture, as before described, and a daylight effect will be produced: whilst, if the two reflectors are then closed, and the back of the instrument opened, the light will pass through the tinted back, and through the picture itself, and the night effect will thus be produced.

PREPARING PAPER FOR THE TRANSFER OF PHOTOGRAPHIC PICTURES.

The subject of this patent is a communication from Jean Théodore Dupuy, of Paris. It was sealed the 19th December, 1862.

This invention consists in a method or methods of preparing paper for the reception of photographic pictures, in order that the said pictures may be transferred to and fixed on wood, porcelain, and other surfaces, all as hereafter explained.

First operation.—Take a sized or unsized gelatinized, albumenized, or cercolinized (cercoliné) paper, (if the paper is not sized it is covered with size, starch, glycerine, or other sizing material), cover it with a solution of ammoniacal citrate of iron and bichromate of ammonia, and dry in a dark chamber. Or the paper may be prepared with the different salts of iron and chrome, with perchloride and lactate of iron, with potassic citrate of iron or manganese, with pyrophosphate of iron, with potassic or ammoniacal tartrate of iron, with bichromate and chromate of ammonia or potass, with the addition of gum gelatine, sugar, or albumen, or Judea bitumen developed in a solution of oil of naphtha and benzine.

Second operation.—The paper prepared by one of the means just described is submitted to light printing in an ordinary photographic printing frame.

Third operation.—The impression or print obtained is submitted damp, say, by exposure in a damp cellar, or to damp steam, breath, or any other suitable damping agent.

Fourth operation.—The dampness condenses on those parts which have not received the impression of the luminous rays. I then colour the print with a vegetable or mineral colour in a state of fine powder, according to the purpose for which the print is intended. Sometimes I apply powder of gold, silver, or other metal.

Fifth operation.—To fix the powder on the print, it is covered with a varnish, such as collodion, benzoin, and ether, varnish, gum lac, caoutchouc, gutta-percha, Judea bitumen, cereoline, copal, gum arabic, dextrine, gelatine, and all boiled oil varnishes and resinous substances dissolved in alcohol, ether, turpentine, chloroform, or ammonia. In some cases I cover the glass with collodion iodized and sensitized with nitrate of silver. After the operation in the dark chamber, or in the printing frame under a negative, the print or impression is developed in a solution of iron or pyrogallie acid; it is afterwards fixed by hyposulphite of soda and cyanide of potassium, the print being washed and placed on a gummed, gelatinized, albumenized, or waxed paper. The picture fixed upon this paper may be transferred as may be desired. To shorten the operation before described, I sometimes cover a glass with collodion chloruretted and sensitized with nitrate of silver, and dry it in the dark, to be used as required. It is afterwards placed in a printing frame under a negative, and fixed by hyposulphite of soda. I wash the print, and cover it with one of the varnishes described under the fifth operation, and then with a gummy varnish.

After the preceding operations have been performed I colour the prints with a brush with mineral colours, if they are to be transferred to surfaces which undergo firing to fix the colours, such as porcelain and earthenware, or with vegetable colours if the prints are to be transferred to wood, leather, or to any other substance not requiring firing to fix the colour. The colours instead of being laid on with a brush may be produced by lithographic or typographic printing.

All photographic prints obtained according to this invention on paper prepared as before described may be transferred to all sorts of objects. Varnish and rectified essence, brushes, a piece of cloth, and a paper knife are all that are required to effect the transfer. To transfer a photograph printed on paper prepared as before described, dip a brush into transfer varnish, and give the picture a thin coating of it; then place this picture with the prepared side downwards on to the object to which it is to be transferred, care being taken that it occupies its correct position when first placed, in order that friction may not afterwards injure it. Next, cover the paper with a piece of slightly damped cloth, and with a paper knife or other convenient instrument rub evenly over the cloth to fix the print on the surface to which it is to be transferred. The cloth must not be too wet, yet sufficiently so to saturate the paper. The cloth is next raised, then with badger or other suitable brush wet the paper with water, and in a very short time it may be removed or peeled off, when the photographic print will be found transferred to the surface on which it was placed, the paper having no trace of it left. The preparation on the print may be afterwards washed off with a soft brush or sponge, and blotting paper may be applied to remove any wet from the print. When the print is thoroughly dry, it should receive a thin coat of varnish.

THE FUMINATING PROCESS.

THE "fuminating process" is the name given to the method of fuming sensitive paper with ammonia. In this country the method does not seem to "take;" but in the States it seems to be gaining general adoption. The following description of the method employed is given by a correspondent of *Humphrey's Journal* :—

"The following brief description of the fuminating process in printing photographs may interest a small portion of those that semi-monthly peruse the pages of your spirited journal. The origin of this process for neutralizing the traces of acid in silvered paper is not of recent date, but may be traced back to the very beginning of photographic printing in this country. As long ago as the summer of 1853 Mr. Duchochois and myself used the ammonia vapour bath, very similar to those used now, and with the same results. At that period, however, the demand for photographs was very small, and the process being tedious on a small scale, we discontinued it, and adopted the ordinary ammonio-nitrate process, which has been very generally used up to the latter part of 1862. If I am correctly informed, Mr. Hugh O'Neil, operator for C. D. Fredricks & Co., was the first to revive the use of the vapour bath, and began using it successfully about one year ago. Since then others, and nearly all in New York, have used it more or less generally with good success.

"There are various modes of constructing boxes or dark chambers for fuminating purposes, of which one is a high box divided in the centre into two chambers by a perforated partition, the upper chamber being provided with cleats and pins, on which several sheets are hung at a time. The ammonia is poured into an open dish and set on the floor in the centre of the lower chamber, the perforated partition serving as a distributor of the ammonia vapour. After the paper has been properly arranged in the upper chamber and the ammonia^o fortis in the lower as described, close the box tight and subject the paper to the vapour for ten minutes; then remove it for use, not allowing it to come in contact with strong solar light. Before vapourizing, the paper must be silvered in the ordinary way, excepting that the silvering solution must contain 60 grains to the ounce instead of 80 or 90 grains, with just enough ammonia to keep it from discoloring. Another mode of making a box is with only one chamber, and opened at the top by means of a door or cover on hinges. The opening in the top is required to be the size of a sheet of paper, having slots countersunk with pins at each corner to hold the paper. By this arrangement a piece of cotton flannel, the size of the box, is saturated with ammonia fortis and spread in the bottom of the box. A sheet of paper is placed on the pins at the top, silvered side down, and the top or cover carefully shut, and left so for two minutes; then raise, by means of a string, a trap door so constructed as to close up under the sheet of paper to prevent the escape of ammonia while changing the sheets. The trap door being closed, raise the outside door or lid and remove the fuminated sheet, placing another on in the same manner as the first, and so on, cautiously avoiding exposure to light."

MAGIC LANTERN SLIDES.

BY H. T. ANTHONY.*

As a great deal of interest is at present manifesting itself in the use of photographic transparencies in connection with the magic lantern, and as transparent positives made by means of the ordinary wet collodion process do not seem to be of a character well suited to this purpose, it has occurred to me to suggest one or two dry processes which in my hands have produced transparencies in my opinion excellently suited to it.

* *Amateur Photographic Print.*

The first is a process which has long been described in the journals, but which, as far as my experience extends, has never met with the favour it merits. It is as follows :—

"Take any good working bromo-iodized collodion, sensitize in the ordinary acetic acid silver bath and wash well after removal from it. Then flow over it a three-grain solution of chloride of ammonium, say for one minute, and wash well again. Finally flow upon it for the same length of time a two-grain of freshly dissolved gallic acid, rinse off and dry. Expose in contact with a negative and develop with pyro and silver in the ordinary manner."

Another process which is characterised by great quickness and ease of development, consists in making use of the ordinary fifteen-grain tannin solution preservative merely modified by the addition of three drops of the purest glycerine to the ounce.

I have made positives by this latter process hardly distinguishable from albumen. The plates prepared in this manner I have found excellent for negatives, being very sensitive and giving more detail in the shadows than the ordinary tannin plates.

Correspondence.

FOREIGN SCIENCE.

[FROM OUR SPECIAL CORRESPONDENT.]

Paris, July 1st, 1863.

At the last meeting of our Photographic Society M. Davanne presented two photographic pictures on paper which had been submitted to the test of exposure in two Exhibitions (1861 and 1862), and which showed no signs of fading or alteration whatever. This, then, may be accepted as a satisfactory proof that photographs, when carefully prepared, are permanent. For the pictures in question were submitted to the severest tests that photographs are ever likely, to be exposed, the conditions being every variation of light heat, moisture, &c., and they remain as fresh and pure as at first. It was also remarked that photographs are more liable to change when kept in a portfolio than under glass exposed to luminous action. A sulphurized proof, if kept in a perfectly dry place, remains for a very long time without exhibiting any signs of alteration, while in a damp place change is immediately evident. Thus, a photograph carefully framed is much better sheltered from humidity than when kept in a portfolio.

M. Rollo presented to the Society a photographic reflector of pure silver, which by neutralizing violent contrasts, admits of our obtaining excellent results in the worst constructed operating rooms, and at hours when exposure was previously impossible; besides this, it gives new and wholly unknown effects, and it may be employed with great economy in enlarging as a powerful reflector of light. It measures forty-eight inches square, weighs about eight ounces, and may be stretched on a frame or on a roller.

Mr. Herman Krone made the following communication upon the preparation of a xyloidine collodion which he calls *nitramidine*. He says: "I have undertaken to prepare a collodion *a la nitramidine* (xyloidine) in order to show the manner in which this body acts in photography. Starch, dissolved in nitric acid, was precipitated by water [C¹² H⁹ (NO³) O¹⁰] (Pelouse). By operating with various proportions of alcohol and ether, we obtain a collodion entirely devoid of coherence in its normal state, without iodine, it dries under the form of a white and opaque film, very adherent to the surface of the glass, viewed through the microscope it appears like a cracked crust. Prepared with iodide of cadmium, this film cracks more than with the other iodides used, it appears like a ploughed field furrowed in every direction. From its want of coherence perhaps this collodion is very slightly photogenic; it requires six times the ordinary exposure. During the operations of developing

fixing, and washing, the surface breaks up piece by piece, in spite of the minutest precautions.

M. Victor Cassaignes exhibited a stereoscope with coloured glasses, upon which he remarks:—

“Objects present themselves to our observation not with their peculiar colours merely; they assume also a general tint resulting from the reflections of other coloured objects falling upon them, or from coloured diaphanous films which intervene between them and our eyes.

The hues under which we see objects in winter or in cold countries differ notably from those with which they are clothed in summer or in warm countries. And the same differences or the greatest contrasts occur at different hours of the day, even when not modified by factitious light, such as the light of a conflagration. Thus, in nature, the same picture presents very different aspects, according as it is viewed in the morning, at noon, or at evening, by sunset or moonlight, under stormy clouds or a clear sky. Still the objects remain the same, and these changes in their aspect are due only to the variations of light. It is these general and delicate hues of nature that M. Cassaignes has sought to imitate in the stereoscope.

He believes that the stereoscopic lenses may be made coloured, or plane coloured glass may be placed over the white lenses, or any transparent coloured films, such as gelatine, may be substituted for the glass. Then the pictures viewed through these stereoscopes will become chromo-stereoscopic, acquiring the colours of the glasses or diaphanous films. The finest effects of light we see in nature may be imitated by this means, and the first advantage of this colouring consists in correcting the snowy aspect which disturbs the harmony of our present stereoscopic views.

By numerous experiments upon the new fixing agent—sulpho-cyanide of ammonium, M. Lewitsky has recognized the solid advantages of this new mode of fixing. MM. Garin and Co., manufacturing chemists, announce that they are prepared to supply the new fixing salt at four francs the kilogramme, equal to eighteen-pence the pound. As the baths require to be saturated solutions, even at that price this fixing solution is very costly. It is to be hoped that manufacturers will be able to reduce the price upon an increased demand arising.

Photographic Notes and Queries.

WERGE'S PLATE CLEANING SOLUTION.

SIR,—I can quite support your recommendation of this preparation, so far as its immediate effect on the plate is concerned; but I think those who try it ought to be cautioned that it certainly contains nitric acid, which, if allowed to be in contact with the fingers for any length of time, may produce troublesome sores. The use of india-rubber finger tips would prevent this. But there is another inconvenience which will be felt by those who use a neutral bath, viz. that a slight trace of acid probably remains on the plate when it is apparently quite clean.

On the whole, I have found nothing so safe (or more efficacious) as the use of old collodion on cotton wool after thorough and careful washing.—I remain, Sir, your obedient servant,
A LONDON AMATEUR.

[We believe all plate cleaning solutions contain acid, and care should be used not to allow the fingers to come much into contact with the solution, and also to polish every part of the plate especially the edges, with a dry cloth, or tuft of cotton wool.]

IRON DEVELOPMENT WITHOUT ACID.

SIR,—Seeing the letter of Mr. Bartholomew in your last on the above subject, I can add my experience as to the possibility, under certain circumstances of working iron salts without acids. About 18 months past I was engaged taking some pictures, and being much troubled by the necessity for unusual length of exposure in the camera, I found on testing that my bath had become very acid. Having no other at hand, and desiring if possible to obtain pictures at once, it struck me that by reducing

the acid in the developer I might to some extent neutralize the extra acidity of the silver bath. After several attempts with increasing success, I tried at last the use of the sulphate of iron alone, and to my great satisfaction obtained pictures full of tone and detail, with very much less exposure. I was using Ponting's simply iodized collodion with acetate in the silver bath; the pictures produced when the light was at its best requiring no re-development. There were no symptoms of fogging, but bright, clear, full-toned negatives: the developer remaining on the plate for a few seconds without apparent effect, when the pictures suddenly started out at once and did not appear to be much improved by keeping the developer longer on the plate.

I have never tried the simple salt with a nitric acid bath, but, theoretically, I should not expect it to prove so successful.—
Yours respectfully,
E. E. L.

ERRATUM.

DEAR SIR,—Allow me to point out a misprint in the NEWS of the 26th instant.

In your account of Dr. Kemp's dry process, No. 3, you say the two halves of a stereoscopic plate had respectively ten *seconds* and twenty *seconds* exposure in his drawing room, with a Dallmeyer's stereoscopic lens, No. 4 stop, on a dull day in December, page 303, line 8 from top of right hand column. On referring to Dr. Kemp's book (page 43), I find he gives the exposures as *minutes*, not *seconds*.—I am, yours truly,
JOS. S. HURST.

[We are obliged to our correspondent for pointing out this error of the press. Of course ten seconds would have been very much insufficient under the circumstances named even with the most sensitive wet plates.—Ed.]

Talk in the Studio.

PHOTOGRAPHY IN TASMANIA.—The *Weekly Times*, published in Hobart Town, proposes to devote a column weekly to the advancement of photography in Tasmania. Correspondents will be answered by a competent person. One of the especial objects will be the formation of a Tasmania Photographic Society. On the subject the editor of the journal in question says:—“We are sure there are a sufficient number of professionals and amateurs to make such a society both successful and valuable. ‘Union is strength,’ and in this case ‘Wisdom;’ nothing would so conduce to the advancement of the art as mutual assistance and encouragement. In England the Societies of this nature embrace all classes. The Heir to the British Crown has become the patron of the London Photographic Society, dukes, duchesses and the nobility of all ranks are numbered amongst its members down to the photo's assistant. Why should otherwise than a gentlemanly mien and intelligent capacity be the qualification for membership? Can we not break through the party walls of station here? Can we not raise photography to the same standing as the other colonies? Excite a generous emulation amongst those who will take an interest in it, and depend upon it, marked results will follow. We surely have sufficient intelligence amongst us—and have exhibited energy enough in the matters which have before engrossed our attention—let the thing be commenced by a few who have a life interest in the matter—a determination to create success, and their ranks will soon be swelled by many who never before were engaged in so beautiful a science. If this be carried out, who knows but that Tasmanians may be looked upon as authorities, and our humble island home be regarded as a seat of learning.

GLUE FOR INLAYING METALS.—To a pint of common dissolved glue used by joiners, add two table-spoonfuls of pulverized resin, and a like quantity of brick-dust. Another preparation of glue for the same purpose consists of a pint of dissolved glue, one ounce of dissolved isinglass, and two ounces of vinegar. Strong glue and fine chalk powder mixed with it is used for cementing ivory to wood.

HOW TO PREVENT FORGERY OF BANK NOTES.—A new idea, to prevent the forgery of bank notes, &c., has just been started. It consists in using a single sheet formed of several layers of pulp, superposed, of different nature and colours, according to requirements. The check it gives to alterations of documents is excellent. It only requires that the middle layer be coloured of a delible or destructible colour. The chemical acid employed

in obliterating the writing will also destroy this colour, which cannot again be restored while the paper surface remains white.

FORMIC ACID.—Mr. Warner in a recent letter says:—I beg to add my mite to the information on this point. To-day I took a negative during a heavy thunderstorm with it, the exposure being four seconds. The developer was as follows:—

Saccharo-sulph. ferri	150 grains
Acetic acid	150 minims
Formic acid	1 drachm
Water	5 ounces
Alcohol	quantum suff.

I got a rich negative with the pyro and formic acid, same exposure, a thin grey, under-exposed image. I quite agree with Mr. Cooper that the iron and formic acid is the best of all.

PATENT ALBUMENIZED PAPER.—The same correspondent says:—I can speak very highly of Sutton's india-rubber paper. I bought a ream the other day of a celebrated maker which is so bad, that I intend returning the remainder.

To Correspondents.

D.—We have submitted your queries to Mr. Blanchard; the following are his answers: 1. This method is not available where thin metallic images are produced. Such negatives must be intensified by some other method. Try a different sample of collodion. In order to produce the best result a rich creamy looking negative is needed to begin with. If, however, after intensification the negative, when dry, appear too thin, the application of bichloride of mercury, saturated solution in cold water, followed by a very weak solution of iodide of potassium, say 2 grains to 1 ounce of water, will bring the negative up to the mark. 2. I have never met with this difficulty but once, and it was then caused by the admission of white light. 3. The plan suggested last week is best.

A SUBSCRIBER FROM THE FIAT has some friends who wish him to take their portraits with their heads under their arms, and he wishes to know how the matter can be managed. We have not seen any such grotesque portraits, but we can conceive it quite possible to produce them by the system of double printing, the exact details of which must be governed by the precise design. 2. If the only disadvantage which age has induced in the collodion to which you refer is thickness, you may dilute it either with new thin collodion or pure ether. If, however, it have become decomposed and insensitive, it may be utilized for cleaning plates. 3. As a rule it is better that the nitrate of silver for the bath should be recrystallized.

A. Z.—From the spots in your sensitized paper always occurring near the corner by which they are pinned, and from the fact that in one of the samples sent a mark, as of the edge of a board, is apparent, it seems likely that you pin them to a piece of wood which is not clean, and where the contact is close spots and stains are produced. This is the only reason which at present occurs to us.

A BELIEVER IN THE OPINIONS OF THE PRESS.—The print just received is a very good one. From what you now state as to your capability to prepare and keep in order your own solutions as well as manage all the manipulations, we should conceive that you will have little difficulty in obtaining an engagement as printer.

C. DE V.—You had better not change the positions of your lenses. They will work best as they are.

D. G. LINES.—Of the two named we should prefer the first, as having the greatest reputation. You can doubtless get them genuine of the house you name.

TYRO.—We cannot speak with absolute certainty of the cause of the poor feeble effect in the prints received. We should have been disposed to attribute much to feeble or forged negatives, had you not stated that the negatives are brilliant. A stronger silver bath, and printing in the shade would, however, have doubtless produced better results.

YOUR PHOTO.—Steadily persevere and you will improve. It is always desirable to complete the operations of exciting, printing, toning, and fixing in one day, if possible. The operations may, however, be delayed for a day or two if the sensitive paper be kept in a dry, dark, cool place. It will not, however, tone so well, or give such good results. Your best method of obtaining a negative will be to go to some good professional photographer, and sit for your portrait, and then purchase the negative. In the print received the paper has either moved in the printing frame, or the camera has been shaken in taking the negative, so as to slightly move everything. You must print and tone deeper.

A READER.—We have met with the troubles you describe with some samples of the enamel paper, but not with all. In most cases the small blisters to which you refer disappear, and leave no trace after drying. The best remedy we have found when the tendency exists, is the use of a stronger silver bath, slightly acid with nitric acid. A good remedy, however, will be another sample of paper. We have generally noticed the streakiness of which you complain, and the tendency to blisters, to belong to the same sample.

HYPO.—The sole cause of the stains in your prints is carelessness or slovenliness in manipulation. The brown looking stain, metallic when viewed in a certain light, is, almost without exception, the result of hypo coming into contact with the print before it is fixed, either when in the printing frame, or whilst washing or toning. If the print be touched with fingers which have been in contact with hypo, and not thoroughly washed afterwards, such stains are certain to be the result. Some persons adopt the very bad plan of fixing some prints whilst others are toning, and it is almost impossible, under such circumstances, to avoid causing stains. The best plan is to complete the printing for the day; then wash all the prints; then tone all, placing each print in a dish of water when done, and then fix all, taking care to lift each print from the water with one hand and drop it into the hypo; then with the other press it properly into the solution. But the fingers which have touched the hypo must never touch the unfixed print, not even to lift it into the hypo.

N. G.—If you send us one of the prints which turn yellow we shall doubtless be able to suggest the cause; but your description is too indefinite to enable us to state without seeing it.

P. T.—After the addition of such a variety of things in indefinite proportion to your toning solution, it is difficult to say what was its operation, or why such and such results followed; in any case your description is not sufficiently precise to enable us to form an opinion. 2. You must cultivate a habit of greater precision. You now leave us altogether in doubt as to the real object of your question. There are several printing processes in which dichromate of potash is used; but you do not state which of them it is, regarding which you require information. One process, headed "Iron Printing Process," appeared in our last. We shall always have much pleasure in giving any information or advice you require; but you must endeavour to be clear and precise in stating your difficulties or requirements.

CUR RESCIAE PUDENS.—A hypo bath would probably have a solvent action on a film of varnish. 2. Sometimes soaking in water alone, especially hot water, will remove the film from varnished plates. A solution of carbonate of soda, or carbonate of potash will readily affect it. 3. The silver bath would probably not be affected by immersing a single varnished plate. 4. Collodion which has lost its fluidity from loss of ether can be put into working condition by the addition of ether. 5. It is not necessary to add chloride of sodium to the bichloride of mercury. 6. When intensifying with bichloride of mercury you may work in a strong light; but it is desirable to avoid a strong light when intensifying by depositing silver, whether it be done before or after fixing. 7. You may return the solution of bichloride of mercury from the plate to the bottle; but remember it gets weaker with use. 8. As you must use a very weak solution of iodide of potassium it rapidly becomes exhausted. It may be used once or twice over, but is generally by that time exhausted. 9. See answer to No. 6. 10. The plate has been imperfectly washed, and so caused irregular action. 11. If the gold is not precipitated add carbonate of soda gradually until the solution is neutral, and then try. 12. Prints from weak negatives often appear to lose more in toning and fixing than prints from vigorous negatives, simply because they do not permit of such perfect reduction in printing without destroying the whites. 13. There is no certain guide to perfect fixing except the use of fresh, strong hypo, and sufficient of it. In some cases the appearance of the print, when examining by transmitted light, having no opaque patches of chloride of silver, may aid the judgment; but it is not a certain guide. Read the chapter in our last ALMANAC on the subject.

A SUBSCRIBER.—From your description it is clear that nitric acid in excess is the cause of your trouble. A large quantity of nitric acid in the silver bath would make it give good positives as you describe; but would make the negative image thin, grey, and metallic. Add a solution of carbonate of soda, a little at a time, until there is a very slight permanent precipitate, the bath will then be neutral. In using litmus paper for testing simply touch blue litmus with the bath, if it turn purple the bath is slightly acid, if it turn more red it is still more acid; if it become a bright red immediately there is a large amount of acid. To test for alkalinity use the reddened litmus paper. Take a piece of blue litmus and hold it over the orifice of a bottle containing acetic acid. The fumes will redden the litmus paper. Any alkaline solution now touching the paper will cause it to become blue. Adding no silver to the developer is a sufficient reason for getting no picture with the majority of dry plates.

CONSTANT READER.—The cause of the meanness is probably too rapid toning and the use of a newly mixed toning bath.

T. G.—With a portrait lens of 11 inch focus from the back you ought to be able to obtain a satisfactorily defined group of 7 or 8 persons on a whole plate, if the lens be good for anything at all. The best plan is, if possible, to arrange the group in a semicircle to suit the curve of the lens. The triple is the best lens we know for groups, but it would not, of course, be so rapid as a portrait lens. Working in the open air, you can probably afford to reduce the size of the stop in the portrait lens, and that will aid you. Please send us one of the prints to examine. We shall have pleasure in receiving the communication to which you refer.

G. J. F.—As a general rule, about 15 grains of protosulphate of iron give good results. In such case use the same proportion of acetic acid. It is not necessary to increase the proportion of acid in the same ratio as the iron.

M. B.—There is an unquestionable difference in the appearance of negatives fixed with cyanide. They are not so brown and non-actinic as those fixed with hypo.

S.—We cannot recommend you to take a patent. Few photographic patents pay, and what we have seen in your results would not justify you in going to the expense of a patent. We think the use of blue glass for lenses a mistake. White glass will permit all actinic light to pass; blue glasses can do no more, but it is quite possible they will do less.

JOHN ALEXANDER.—In reference to the preparation of formic acid, we may remark that if you are familiar with chemical manipulations, the following proportions will aid you, perhaps, in producing the acid. This method of producing this acid is only of recent introduction. Into a retort of 2 litres capacity put 1 kilogramme of oxalic acid, 100 grammes of water, and 1 kilogramme of glycerine; distil at a temperature between 100° and 200°, avoiding a higher temperature; add $\frac{1}{2}$ a litre of water from time to time till 6 or 7 litres have come over. With care this will be found an excellent method, giving the formic acid quite pure, and yielding the theoretical quantity.

Several correspondents in our next.

Photographs Registered during the Past Week.

- MR. JAMES BURKE**, 44, Lower Ormond Quay, Dublin,
A Photograph described as "A Group of Beauties."
A Photograph described as "Twelve Gems of Statuary."
Photograph of Sir Walter Scott.
- MR. A. S. WATSON**, 2, Regent Road, Great Yarmouth,
Photograph of Sir Thomas Beevor.
Photograph of Lord Sondes.
- MR. NORMAN MACBETH**, 28, Sixe Colong Place, Edinburgh,
Photograph (taken from oil painting) of the late Rev. Francis Gillies, Minister of St. Stephen's Free Church, Edinburgh.
Photograph of Alexander Russell, Esq., Editor of the Scotsman Newspaper, Edinburgh.

THE PHOTOGRAPHIC NEWS.

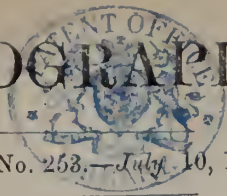

VOL. VII. No. 253. — July 10, 1863.

CONTENTS.

	PAGE		PAGE
Photography in Paris.—The Exhibition	325	Proceedings of Societies	334
The Decimal System of Weights and Measures.....	326	Formic Acid. By Z. J. Godimus	335
Scientific Gossip	327	Photographic Notes and Queries	335
Critical Notices	328	Miscellaneous	335
Balloon Photography.....	329	Talk in the Studio	335
The Aesthetics of Portraiture. By R. Disderi	330	To Correspondents	336
Stereoscopic Manipulations in the Field.....	332	Photographs Registered during the past Week	336
A Simple Method of Transferring, &c. By Dr. Schuauus	333		

PHOTOGRAPHY IN PARIS.

THE EXHIBITION.

IN an exhibition of photographs at Paris, we generally expect to see some of the finest specimens of the best men of the time. It is somewhat singular, however, that some of the first Parisian portraitists do not exhibit in the present exposition. The display of pictures is, however, very perfect, and includes some pre-eminently interesting contributions.

The first impression which strikes us on entering the exhibition, is one of gratification on contemplating the position in which photography is placed by the government. Here a very perfect gallery in the *Palais de l'Industrie* is awarded to photography, immediately adjoining, and in connection with, the exposition of works of fine art, which is equivalent to our Royal Academy exhibition. The gallery is spacious, lofty, and well lighted. The photographs are well hung, within eye-range on the walls, and on small transverse screens. All the productions of each artist are placed together, and numbered consecutively. The catalogue is arranged with the names of contributors in alphabetical order, each name forming a distinct heading, with the contributions stated underneath. The ample space and admirable arrangement add much to the comfort of visitors, and, by preventing confusion, aid materially in obtaining a satisfactory examination of the contributions.

At intervals of half an hour M. Lauerie, the Secretary, delivers a brief address, or rather series of addresses, on the most interesting pictures exhibited, proceeding from place to place and pointing out examples of different processes, the details of which are briefly stated, any questions from the audience being courteously answered. Amongst the subjects thus brought under especial attention were the various carbon processes; photolithography and photo-engraving; photography in colours; and, finally, Mr. Robinson's fine composition "Bringing Home the May," which elicits much admiration on all hands. This picture is admirably hung and lighted, and is seen to much greater advantage than it was in the dingy gallery in Sussex Street. As Englishmen, we have much reason to be gratified at the position awarded to this picture, which is without any rival in France, and at the ungrudging admiration it has received amongst French photographers and lovers of art generally.

By far the greater part of the contributions consist of portraiture, the bulk of which is very good. We were glad to observe that a reaction in favour of large portraits seems to have set in. There is a comparatively small display of card portraits, compared with those of larger size. Large busts and half lengths on whole plates, and full length figures on plates 10 by 8 or 12 by 10, largely prevail in the exhibition. Many of these are admirably posed, and are also very fine examples of photography. In the majority of instances these are slightly retouched. It is but fair to add, however, that this retouching appears, in the majority of instances, to result rather from fastidious taste in the artist than from imperfections in the pictures.

Obtrusive lights, arising rather out of the nature of the subject than from imperfect photography, are taken down, sharp crisp touches given here and there. To exhibit a picture without retouches appears to be less a matter of pride than to exhibit a good picture; and if retouching will improve the result it is done without hesitation. Vignette heads, on 5 by 4 plates, were exhibited by several artists. Many of them were very fine, and we fancy with become popular in place of card portraits.

We were glad to perceive that there was but one frame of "postage stamp" portraits, and these were poor. The experiment of introducing this style of portraits has, we understand, proved an entire failure in Paris, the good taste of the inhabitants rejecting such puerilities. We deprecate very much the degradation of the art to the production of mere toys or playthings, which can have no possible artistic value, and which, by decreasing the demand for other portraits, may materially interfere with the commercial results to professional photographers. We apprehend that "postage stamp" portraits will meet with as little favour in this country as in France, unless professional photographers of standing indiscreetly aid in giving them a factitious popularity.

Besides the display of ordinary good photography, there were several essential novelties or processes of peculiar interest illustrated. Amongst these the specimens of photography in natural colours, by M. Niepce de St. Victor, excite much interest. These consist of reproductions from coloured pictures upon silver plates. By means of recent improvements in the process, M. St. Victor is enabled to give them a durability in the light of about twenty-four hours. The Secretary exhibits the specimens for a few moments at each of his half-hourly addresses, and then quickly returns them to the box in which they are kept. The colours are very vivid, especially a fine yellow, of the tint known as Etruscan yellow; the scarlet is also vivid. There are pinks, blues, greens, and some other tints. The general effect of the pictures is similar to that of an un-fixed Daguerreotype, the image being imbedded in a kind of film, something like the unaltered film of iodide of silver on the Daguerreotype plate. The pictures are extremely interesting as demonstrating the possibility of reproducing natural colours by the aid of photography; but they do not at present promise to be of further value.

Amongst carbon prints some of M. Charavet are by far the most perfect we have seen. Some of the portraits exhibited seem to leave little to desire as to delicacy, half-tone, and perfect modelling.

Perhaps the most wonderful application of photography, illustrated in this exhibition, is the invention of M. Willeme, known as photo-sculpture, by which process several fine statuettes exhibited have been produced. By the courteous introduction of M. Lacan, to whose good offices we are indebted for much of our pleasure in Paris, we were enabled to witness the operations in M. Willeme's *atelier*, and shall, on another occasion, give a detailed description of the manipulations.

Nothing in this exhibition interested us more than the contributions, prints and negatives, by M. Blanquart Evrard, intended to demonstrate, as the catalogue states, that by the method recently published by the author (See PHOTOGRAPHIC NEWS, p. 281 and 306) "the photographer can, without the aid of the camera, continue to complete his negative, change the effect, and correct it by means of light." The negative exhibited is of a group of sculptured figures in *bas relief*, apparently from a frieze. These figures, of course, all occupy one plane; but, to show the capabilities of the method proposed, several of the figures have been made much more brilliant and dense, and appear to stand out in much bolder relief than the others. The original negative is soft and grey; but the figures which have received the extra exposure, described by the author, are of much warmer and more non-actinic colour. The method is, we think, well worthy of further attention, as giving great scope for obtaining additional artistic effect in photographs, without the re-touching of the pencil.

Examples of a somewhat amusing modification of the stereoscope to which the inventor, M. Cassaignes, appears to attach great importance, are exhibited. The improvement consists in placing in front of the lenses strips of glass possessing graduated colours. These coloured glasses can, by the aid of a pinion, be moved so as to bring different tints between the eye and the picture, in order to vary the aspect under which the scene depicted is examined. By variations of blue, green, yellow, and red, the effects of sun-rise, and sun-set, mid-day, and moonlight, can be imitated. The method is patented in France and several other countries, but although a pleasing toy is produced, we fear the result will not be commensurate with the expense.

In comparing the photography of Paris with that of London, we are not struck with any superiority in the former over the latter, except in one particular. The best French photographers do not excel in any respect the best English photographers; we are not sure that we saw anything in Paris, which of their kind equalled the whole plate vignettes of Mr. T. R. Williams; but in universality of excellence, Paris takes precedence of London. There are more good photographers, a greater number whose works are uniformly excellent, than there are in our own metropolis. We are now speaking of portraiture; in landscape and some other departments, we have no hesitation in claiming the palm for English photographers. Indeed, we have good reason nationally to be satisfied with our position in the present exhibition. There are not more than half-a-dozen English exhibitors, but the very highest position in several departments is unquestionably occupied by Englishmen. The best landscapes exhibited are by Mr. Maxwell Lyte; the best instantaneous pictures, by Col. Stuart Wortley; the best reproductions by Mr. Bingham; the best composition picture perhaps the best picture of any kind in the exposition, by Mr. Robinson. Nothing can exceed the beauty of some of the instantaneous transparencies of MM. Ferrier and Soulier, but they are produced by English lenses, and some of the instantaneous street scenes on paper by other photographers are not comparable with those of Wilson, England, or Blanchard.

But in every department of portraiture there are fewer bad pictures in the Exhibition than are found amongst the productions of some of our own professional photographers. Some of the first portraitists, as we have observed, do not exhibit. Disderi, of whose establishment we shall have something to say shortly, does not exhibit. Levitzky does not exhibit; but some of his pictures, which were shown to us by M. Lacan, were amongst the finest we have ever seen anywhere.

In our next we shall have something to say on the methods of operating in Paris.

THE DECIMAL SYSTEM OF WEIGHTS AND MEASURES.

PHOTOGRAPHERS are especially concerned in any measure which contemplates reform or revolution in the present sys-

tem, or, rather, no system, of weights and measures. On Wednesday evening week a Bill for introducing the decimal and metric system into this country, was read a second time in the House of Commons. We have no great faith that the measure will pass during the present session of Parliament. Honourable members generally, were very willing to affirm the principle of the Bill, but very many are opposed to the trouble involved in carrying it out. A general impression prevails, however, that it is but a question of time, and that this change must inevitably come. Such being the case, it appears to us to be sheer folly to delay the matter. Mr. Ewart, in proposing the second reading of the Bill, said that to obtain a uniform system of weights and measures had been the dream of the Legislature ever since the passing of the Magna Charta. To attempt to obtain uniformity with the heterogeneous systems in existence would be a most hopeless task. And, as a simple, philosophical, and perfect system already prevails throughout the greater part of Europe, nothing can be more reasonable or convenient than its adoption.

The anomalies which exist are familiar to most persons; but it may, nevertheless, be interesting to place a synoptical view of some of them from the much quoted pamphlet on the subject, by Professor Leone Levi:—

"For measures of length we have the ordinary inch, foot, and yard. In cloth measure we have yards, nails, and ells. There are four different sorts of ells. For nautical purposes we have fathoms, knots, leagues, and geographical miles, differing from the common mile. The fathom of a man-of-war is 6ft.; of a merchant vessel, 5ft.; of a fishing smack, 5ft. We have also the Scotch and Irish mile, and the Scotch and Irish acre. There are several sorts of acres in the United Kingdom, and there are a great variety of roods. We have in almost every trade measures of length specially used in those trades. For the measurement of horses we have the hand; shoemakers use sizes; and we are compelled to adopt gauges where the French use the millimetre. The gauges are entirely arbitrary. The custom of the trade is the only thing which would decide the question in case of dispute. For measures of capacity we have 20 different bushels. We can scarcely tell what the hogshead means. For ale it is 54 gallons; for wine 63. Pipes of wine vary in many ways; each sort of wine seems to claim the privilege of a different sort of pipe. For measures of weight we have about 10 different stones; a stone of wool at Darlington is 18lb., a stone of flax at Downpatrick is 24lb., a stone of flax at Belfast is 16½lb., but it is also at Belfast 24½lb., having in one place two values. The cwt. may mean 100lb., 112lb., or 120lb. If you buy an ounce or a pound of anything, you must inquire if it belongs to Dutch, troy, or avoirdupois weight."

Photographers are very familiar with some of the difficulties which arise out of this confusion. They purchase their materials by avoirdupois weight, the ounce of which only contains 437½ grains; but they prepare their solutions by apothecaries' weight, the ounce of which contains 480 grains. Thus, when a photographer purchases an ounce of nitrate of silver, and makes it, without further weighing, into a 30-grain nitrate bath, he probably adds 16 ounces of water, regarding it as 480 grains, forgetting that he purchases by one standard and works by another. "Why," we were recently asked by a gentleman in Paris, "do you not adopt the system in the News of stating all formulæ in grammes, since that method is becoming so common amongst scientific men?" Our reply was, that we were attempting to introduce it gradually to the notice of our readers, from a conviction that it would shortly be adopted universally. We have frequently of late given extracts from foreign journals, without converting the figures into English denominations; but we have generally met with remonstrance from some of our readers when such figures have appeared.

The metrical and decimal system was introduced into France towards the close of the last century. Some of the ablest mathematicians of the day devoted their attention to the subject, and made the necessary calculations. The system has been found to work admirably in practice, and has since been adopted in Spain, Portugal, Holland, Switzer-

land, Sardinia, Tuscany, Belgium, and various other countries, materially facilitating not only freedom of intercourse between such countries, but effecting an immense saving of time to each of the inhabitants in the simplification of all kinds of accounts.

The introduction of the metrical system is not a necessary concomitant of the decimal system; but it is so perfect in principle and working, and the harmonisation of weights and measures throughout the civilised world is an object so desirable, that we do not think the trouble, confusion, and annoyance which the change will, for a while, doubtless engender, can be compared with the great and lasting advantage to be obtained. The metrical system derives its name from the standard of measures adopted, which is derived not arbitrarily, but from a fixed physical source.

The ten-millionth part of a quarter of the earth's meridian is the unit from which the calculations are made. This unit, or first measure, is called the metre (from the Greek word *μετρον*, measure). It is thirty-nine inches and three hundred and seventy-one-thousandth parts of an inch of our measure (39.371 inches). The metre is divided into ten parts, each of which is called a *decimetre*; and this is again divided into ten parts, each of which is called a *centimetre*.

A cubic decimetre is called a *litre*, and this is taken as the unit of measures of capacity.

A cubic centimetre of distilled water, at its maximum density, that is, at a temperature of 39.5° Fah., is taken as the unit of weights, and is called a *gramme*. All the subdivisions and multiples of these units are by tens, and as will be readily seen, the calculations become simple and easy in the extreme.

Our especial object in bringing it before our readers, now that a measure bearing on the subject is before Parliament, is to urge upon photographers to render themselves familiar with the terms and their value in the new system, and thus prepare themselves for the change which will, we hope, speedily come.

Scientific Gossip.

THE MAGNESIUM LIGHT—PATENTS FOR METHODS OF PROCURING THE METAL.

WE have, on several occasions, drawn attention in these pages to the metal magnesium, and have expressed a hope that some day the metal could be obtained in sufficient quantity, and at a sufficiently low price to render it available for the uses of the photographer. The wonderfully brilliant light which is produced by its combustion, the absolute innocuousness of the evolved products, and the ease with which the light can be obtained at any time, with no more trouble than is required to light a candle, all tend to show that the perfection of artificial photographic light would result from the burning of this metal in a properly arranged lamp. Many attempts have been made, with varying degrees of success, to introduce an artificial light sufficiently powerful to enable photographs to be taken by its means at night, or in dark caverns, where no photography would otherwise be possible; and, in many cases, fair success has been met with. The light evolved by all such pyrotechnic mixtures is, however, very feeble, as compared with sunlight, unless an inordinate amount of material be employed, and, in this case, the fumes evolved are difficult to remove readily from the place where the light is produced, and unless they are perfectly removed their poisonous character makes them very dangerous. The magnesium light would be superior in both these respects. A thin wire simply held between the fingers, can be lit as easily as a piece of paper, and burns like a candle, producing a light which is, according to Bunsen's estimate, only about thirteen times less intense than actual sunlight. No injurious fume is evolved during the combustion. A light white smoke is seen rising from

the metallic flame, but this is nothing but magnesia, and is quite harmless. Moreover, the greater portion of the magnesia remains behind, as a friable solid, retaining somewhat the shape of the original wire.

We believe an arrangement of lamp for the magnesium light has already been devised. A spool of wire is gradually unwound, the end being pushed horizontally into the flame of a spirit lamp, where it ignites and continues to burn as long as it is fed with wire. It is in this feeding that the great difficulty has resided. Although it has long been well known, thanks to the labours of Deville and Caron, that magnesium could be procured even easier and at a less price than aluminium, by a slight and obvious modification of the apparatus used to prepare the latter metal, no one cared about risking the necessary outlay requisite to procure the metal in large quantities, when there was a doubt as to whether there would ever be sufficient demand to make the manufacture pay. Now, however, there appears to be a chance of scientific men procuring magnesium at about one-fourth of the price hitherto charged; and as the sensation which is now rising about this metal will doubtless have the effect of introducing as many improvements and lowering the price in as great a degree as have taken place with aluminium, there is little doubt that it will shortly become all the rage, more especially since in colour, lightness, and other qualities it is really a beautiful metal. Before we treat of the more recent patent for the manufacture of magnesium, let us see what has been done before in the matter. Mr. Sonstadt has just taken out a patent in which he claims an immense number of processes and reactions connected with this manufacture; let us examine how the process stood at the time his specification was taken out, so as to be able to judge whether there is any novelty, and, consequently, any value in the recent patent. In Gmelin's chemistry are given processes for the preparation of the metal by the action of potassium and chloride of magnesium, and many of its properties are correctly given as described many years ago by Bussy. In the *Comptes Rendus* for February 23, 1857, Messrs. Deville and Caron gave a detailed paper on the preparation of magnesium, in which they say that it can be prepared by the process employed for aluminium, which, however, must be slightly modified, as magnesium is lighter than the scoria from which it is produced. A mixture of chloride of magnesium, chloride of sodium, and fluoride of calcium is made, and finely powdered. Sodium, in fragments, is then added and intimately mixed with the chlorides, and the whole is thrown by means of a little iron spatula into a red-hot earthen crucible, which is then closed with its cover. In a short time the reaction takes place. When all noise has ceased the crucible is uncovered and the mixture is stirred with an iron rod until the globules of magnesium are distinctly seen. The crucible is then allowed to cool, and when the saline mass is ready to solidify it is again stirred with the iron rod, which collects the separate lumps of magnesium into one mass. The metal is then distilled in a current of hydrogen and then fused in a flux composed of chloride of magnesium, chloride of sodium, and fluoride of calcium. The latter is added to increase the fusibility of the bath.

Messrs. Deville and Caron still worked at the subject, and more recently gave an improved process for the preparation of the metal, in which they recommend the omission of the alkaline chloride, and only use chloride of magnesium mixed with fluoride of calcium for the reduction by sodium, although they state that good results were also obtained by using a mixture of chlorides of magnesium and sodium. They give improved methods of separating the metal from the flux and for melting and casting it into an ingot. Respecting the properties of magnesium they describe it as a silver white metal melting at about the same temperature as zinc, and like it boiling and distilling at a higher temperature. Like zinc it also takes fire and burns at a temperature a little above its melting point. The density of magnesium is 1.75. In the crude state it is brittle, but by distillation it is

rendered pure. The residue left upon the distillation of impure magnesium is a light, black substance, and the distilled metal is covered with crystals of nitride of magnesium which, however, rapidly decompose water upon exposure to the air. When pure, the metal is very ductile; it tarnishes in the air, but not more quickly than zinc, and the oxidation is never very considerable.

So matters stood until Mr. Sonstadt came into the field. The scientific public had been assiduously prepared for the reception of this gentleman's improvements by paragraphs and rumours of something wonderful shortly coming out in the magnesium line. Lumps of magnesium as big as a man's head were mysteriously talked about as having been seen by somebody who knew a friend of the speaker's, and altogether chemists were prepared to welcome with interest a process for preparing magnesium which should introduce a really novel idea in the manufacture of the earthy metals. Judge then how general was the disappointment when upon the publication of the specification it was seen that, almost buried in a host of details of neither sense nor value, the process was Deville and Caron's original method, slightly modified for the worse by the omission of some of their improvements, and by the preparation of some of the materials in a less convenient manner. The specification is tediously long. The first part consists of a long description of a way Mr. Sonstadt has discovered to purify magnesia from sulphates. The novelty—or want of novelty—of this process will be apparent to all our readers when we say that it consists in precipitating sulphate of magnesia with carbonate of soda and washing the precipitate till free from sulphuric acid. This is converted into chloride, mixed with chloride of sodium and evaporated to dryness. The dried material is then placed in a *platinum crucible* (!) and heated to redness. This mixed chloride is then heated to redness in an iron crucible with sodium, and the magnesium is separated from the slag by washing away the salts and picking out the lumps of metal. These are then fused into one lump under chloride of magnesium. The method of preparing the chloride of magnesium is given, the only novelty consists in using a platinum crucible. The patent concludes by a description of the physical and chemical properties of magnesium, which in many respects are identical with those given by Deville and Caron, whilst in others they are imperfect. We have very carefully studied this specification and we can assure our readers that the only points in it which possess the least approach to novelty are the employment of platinum crucibles in one stage of the operation, and the employment of iron crucibles in another stage. Deville likewise proposes to add fluoride of calcium to his magnesium chloride to facilitate its fluxing, and renders the crude metal perfectly pure by distillation. These improvements are omitted in Mr. Sonstadt's specification.

If such a patent as this can stand for a moment, consisting as it does of scarcely anything but wholesale appropriations of other persons published discoveries, there is little doubt that the patent laws require amendment.

Critical Notices.

ELEMENTS OF PHOTOGRAPHY. By CHARLES HEISCH, F.C.S., Lecturer on Chemistry at the Middlesex Medical College. London: Murray & Heath.

This is one of the least pretentious, but at the same time most thoroughly intelligent and trustworthy, of all the instruction books which have emanated from the press. Mr. Heisch is a very old and experienced philosopher, and a first-rate chemist; he possesses, moreover, the art of communicating the knowledge he has gained in the clear, simple, and forcible language, which is of the highest value in a manual of instruction. The author disclaims the intention of producing anything new; but, nevertheless, old facts and formulas are so rationally stated, as to give them a new value.

The chapter on collodion is a most interesting and valuable one, and we shall take an early opportunity of transferring some extracts from it to our columns. The only point which by intelligent authorities will be considered questionable is the introduction, besides the alkaline processes, of a formula for toning with hyposulphite of gold. This is a subject upon which the author has afortime, we believe, defended his opinion, maintaining that if properly conducted the *sel Dor* toning process gives as much theoretical promise of stability in the prints as any other method. We confess, however, that we should prefer to place in the hands of beginners the alkaline or neutral processes only, as less dangerous than those involving the possible action of sulphur. With this exception we can most cordially recommend the little book.

PHOTOGRAPHIC ILLUSTRATIONS OF THE LADY OF THE LAKE. By THOMAS OGLE. London: Alfred W. Bennett.

MR. BENNETT evidently has great faith in the value of photography as a mode of illustration, and to his enterprise the public is indebted for some of the very best examples of this application of the art. The elegant little volume before us is a novelty in this direction: it consists of a very pretty album containing twenty-four card pictures, illustrating the glorious Scottish landscapes immortalized as the scenes of Scott's "Lady of the Lake." The text is supposed to be in every gentleman's library, and we have here the photographs only, duly numbered and named. Some of the photographs are very excellent indeed, and the whole is got up in a very creditable manner.

THE WYE: ITS ABBEYS AND CASTLES. By WILLIAM and MARY HOWITT. The Photographic Illustrations by BEDFORD and SEDGFIELD. London: Alfred W. Bennett.

The text of this little work is extracted from the well-known volume by William and Mary Howitt, "The Ruined Abbeys and Castles of Great Britain." There are half a dozen excellent photographs—four by Bedford and two by Sedgfield—of scenes which have become almost the property of photography—Chepstow Castle, Tintern Abbey, Raglan Castle, Goodrich Castle, the Wye, &c. The volume will form a most elegant gift-book, and we heartily recommend it.

THE PRINCIPLES AND PRACTICE OF PHOTOGRAPHY FAMILIARLY EXPLAINED. By C. JABEZ HUGHES. Fifth Edition, considerably enlarged. London: Published by the Author.

MR. HUGHES' manual after rapidly running through four editions, has in the fifth, doubled its original size. From a simple manual of instruction, it has grown into one of the most complete text books yet published. We need not repeat here all we have before said as to the excellence of the style, and the value of the information it originally possessed; but we must refer to the added matter of the present edition. The work is now divided into three parts: the first consists of instructions for the beginner, comprising all kinds of elementary information. The second part consists of a very complete synopsis of all the dry processes which have had their claims approved by the production of good results. The third part consists of a vast mass of all kinds of information relating to almost every branch of photographic practice. This chapter is a perfect *omnium gatherum*. The author gives not only his own experience, but also hints from almost every one of ability who has written upon the art, with the source of each hint duly acknowledged. Thus in the Chapter on Cleaning Plates, we have no less than eight recipes for plate cleaning solutions, each verified by the

name of its author. We have similar chapters on Intensifying, on Copying, on Enlarging, on Instantaneous Photography, on Transparencies, on Recovery of Gold and Silver from Residues, on Colouring Pictures, on Printing, Toning, &c., and on a host of other interesting topics. The work, unless we are mistaken in our estimate of it, will very shortly be a text book of daily reference in the hands of every photographer, professional and amateur. Our space does not permit us to make extracts in the present number, but we hope to do so on another occasion.

BALLOON PHOTOGRAPHY.

Mr. GLAISHER recently made another scientific balloon ascent, and was on this occasion supplied with dry plates prepared by Dr. Hill Norris; but, unfortunately, no opportunity occurred of exposing them. We subjoin a few extracts from his account of the ascent, which took place on the 3rd ult. from Wolverton:—

We left the earth at 1h. 3m. p.m.; at 1h. 7m. we were at the height of 2,000ft.; at 1h. 15m. we passed above 8,000ft.; a height of 10,000ft. was reached at 1h. 17m.; in nine minutes afterwards we were 15,000ft. from the earth, and rose gradually to about four miles and a quarter at 1h. 55m. On descending at 2h. 8m. we were 20,000ft. from the earth; at 2h. 13m. above 15,000ft.; at 2h. 17m., 10,000ft.; at 2h. 22m., 5,000ft.; and on the ground at 2h. 28m.

Before starting, the temperature of the air was 66°; it decreased rapidly on leaving the earth; was 54° at 3,000 feet high; 49° at 4,000 feet; 41° at one mile; 30° at two miles; and, up to this time, every succeeding reading was less than the preceding, but here the decrease was checked, and while passing from two to three miles the temperature at first increased to 32°, then decreased to 29°. A second increase followed, and at the height of three miles and a quarter the temperature was 35°. A rapid decrease then set in, and at three miles and a half the temperature was 22°. From this time till the height of four miles was reached the temperature varied frequently between 22° and 18°, and at the height of four miles and a quarter the lowest temperature took place—viz., 17°. On descending, the temperature increased to 26°, at the height of 23,000 feet, and then to 32° at the height of four miles. It then decreased 9° in one minute, to 23°. It continued at this value for some time; then increased slowly to 29°, at 19,000 feet, and continued almost constant for a space of 2,000 feet; then increased to 32° at 15,000 feet; and was 32° or 33°, almost without variation, during the snow storm, which we experienced from 13,500 feet to 10,000 feet high, when an increase set in. At 5,000 feet the temperature was 41°, and 66° on the ground.

We reached some clouds at 1h. 9m.; at 1h. 16m. we saw a very faint sun, and expected, as usual, its brilliancy would increase, and that we should soon break into clear sky. At the highest point reached, about $4\frac{1}{2}$ miles, the sky was very much covered with cirrus clouds; the sky as seen between them was of a very faint blue; as seen from below through a moist atmosphere we were above clouds, but there were no fine views or forms, all was confused and dirty-looking, no bright shining surfaces, or anything picturesque, and the view was exceedingly limited, owing to the thick and murky atmosphere.

At 2h. 3m. on descending we lost even the faint sun, and re-entered fog, and experienced a decline of temperature of 9° in little more than a minute. At 2h. 6m. there were faint gleams of light, fog was both above and below, but not near us. At 2h. 7m. large drops of water fell from the balloon, covering my note-book; the next minute we were enveloped in fog, which became very thin at 2h. 14m. At 2h. 14 $\frac{1}{2}$ m. rain fell pattering on the balloon; this was shortly succeeded by snow, and for a space of nearly 4,000 feet we passed through a snow storm; there were many spiculae, and cross spiculae, with snow crystals small in size, but distinct; there were few, if any, flakes, as we descended the snow seemed to rise above us.

I took up Herschel's actinometer, and once only, at four miles high, the sun shone on it, during which time the reading increased nine divisions only in one minute, while on the ground Dr. Lee and myself, at eleven o'clock in the morning, had determined the increase of thirty-three divisions in one minute.

This instrument I hope to be able to use at great heights on future occasions. At the height of three miles a train was heard, and at a height exceeding four miles another train was heard. Those heights are the greatest at which we ever heard sounds, and indicate the generally moist state of the atmosphere. Before quite reaching the highest point I examined portions of the blue sky with a small spectroscope, kindly procured for me from Paris by Mr. Simms, which I could readily use anywhere, and the spectrum was seen just as from the earth under the same circumstances. I could not use the large spectroscope at all throughout the journey, and through the thick atmosphere and large amount of vapour I was unable to make any use of the camera kindly prepared by Mr. Melluish, with plates specially prepared by Dr. H. Norris, of Birmingham. This ascent must rank among the most extraordinary ever made; the results were most unexpected. We met with at least three distinct layers of clouds in ascending, of different thicknesses, reaching up to four miles high; when here the atmosphere, instead of being bright and clear, as it has always been in preceding ascents, was thick and misty, but perhaps the most extraordinary and unexpected result in the month of June was meeting with snow and crystals of ice floating in the atmosphere at the height of three miles, and of nearly one mile in thickness.

Mr. Negretti has received a large number of suggestions for overcoming the difficulties he encountered in his attempts at balloon photography. He writes to the *Daily Telegraph* on the subject, as follows:—

Allow me through the medium of your journal to answer *en masse* the numerous correspondents who have honoured me with their counsels and suggestions, with reference to my late balloon experiments, and to apologise to them for not answering them individually. I would begin by way of a general reply to remind them that:—1st. The car of a balloon is of limited size. 2nd. That the car is for the best of all reasons made of flexible materials, *i.e.*, wicker work. 3rd. That the balloon will only carry a limited weight. 4th. That the balloon, itself, is made of a light textile fabric; and 5th, that the balloon goes with the wind and not through it, in fact, just as a barge drifts with the tide. Now, having considered these points, it will be evident that a stiff sail and boom could not be attached to a soft flexible balloon, as suggested by one gentleman; nor, as hinted by another, could a rudder from the car be conveniently used, from the fact that the necessary gear would take up more space in the car than I could spare; and even if its adoption were practicable I feel confident it would not be of any use for the reasons stated above. Moreover, I believe the overhanging rudder would tend greatly to make the balloon more unsteady. There is a plan that seems to have found general favour with my advisers, and has been suggested as likely to get me over my difficulties with reference to the rotatory motion of the balloon; the remedy for this annoyance is that I should use a gyroscope as a stand for my camera. Now, sir, there is no one who admires that beautiful instrument more than I do, and there is no question that by employing a gyroscope I should obtain all the steadiness that I require for my pictures. Mr. Piazza Smyth, the Astronomer Royal for Scotland, made use of a gyroscope on board the late Mr. R. Stephenson's yacht, for taking astronomical observations at sea. This was whilst on his passage to Tenerife, but Mr. Piazza Smyth had the deck of the *Titania* on which to place his gyroscope, and a crew of sturdy sailors to set it in motion, and not the circumscribed space of a balloon car.

I am afraid that the gentlemen who kindly suggested the gyroscope have not given the subject their serious consideration. My opinion is, that, supposing no ropes or ring were in the way, which absolutely prevents an apparatus of the kind being used, a gyroscope and spinning gear that would support and keep steady, in any position, the camera and lenses required, would weigh several hundredweights, and would take the united exertions of three or four persons to set it in motion. I need not say that I never could hope to adopt this plan. No, Sir; if photography is to be done from a balloon, the photographer must mainly depend on having suitable and appropriate apparatus for keeping his camera freely and steadily balanced, on skill in manipulation, the rapidity with which he can expose the sensitive plate, and judgment in seizing the right moment for exposure, for there are moments when there is only a progressive movement, which, if towards or leaving an object even

at the rate of 15 or 20 miles an hour, every photographer knows we care very little about.

Messes Nadar and Goddard did, in 1858, try to take photographs from a balloon fastened to the ground with ropes, but even with the balloon in this captive state, they did not succeed in obtaining sufficient steadiness for their purpose. Photography has made wonderful progress since that, and, for all that, is still in its infancy. Up to the present time I believe I am the first person who has ever taken a photograph from a free balloon. What now seems a difficult matter will be eventually a very simple affair, and in my present task I am only attempting to forestall the regular course of events.

Mr. Negretti here overlooks the fact that some successful experiments in photography from a balloon have been made in the United States. In the year 1860 Mr. Black ascended from Boston, and exposed six plates. Of these two were stated to have been very successful. The results were shown to the American Photographic Society, and described as clear and sharply defined, giving a view very similar to that seen by the aeronauts. What methods were employed to overcome the difficulties in the way, we do not remember. The object of the ascent was, if we remember rightly, to ascertain how far the operation could be made useful in military reconnaissance.

THE ÆSTHETICS OF PORTRAITURE.

BY R. DISDERI.*

Nothing in photography appears easier at first sight than a portrait. It seems sufficient, to ensure the desired result, that the model should remain perfectly still, and that the operator employ the shortest possible method. Does not the light copy the object with perfect accuracy, and give a faithful *fac-simile*? How is it, however, that so many portraits are not at all good likenesses, and that it is so rare that the resemblance is so complete as to satisfy the friends and the relations of the individual who has been the model? How is it that the different representations of the same person are so varied that they sometimes express very different, and sometimes even opposite characters? Are there not amongst the same portraits those which may be considered as good likenesses, some equally pleasing and others ugly? What is then the meaning of this difference in the copies of one and the same object, if it be not that this object presents infinitely varied aspects, amongst which only a small number are capable of giving an exact and pleasing representation of its true character, which alone constitutes the portrait? In truth, to make a portrait it is not necessary to reproduce that proportion or form of the individual with mathematic exactitude; but it is requisite, above all, to represent them according to the character of the individual, with the modifications and developments which have been given to him by habit, opinion, or social life. Those who know the individual to be represented will come to a very clear understanding on this point which is the result of all the various aspects in which they have seen him; if they knew how to express this idea, they would render the portrait truly resembling. The artist must see and comprehend his model in the same way. In addition to this, he must attempt the beautiful without losing anything of the truth.

Neither the photographers nor their models are impressed with this idea. They prefer to think that the resemblance consists in the exact reproduction of the proportions, the features, and the attire. Thus portraits are very often caricatures of individuals, representing only the unpleasant traits of the original, with something of his features by which he may easily be recognised. In such photographs the details are the most admired. One recognises the beard, the dress, the various peculiarities of the individual that are even more insignificant than those we have just mentioned; and sometimes we may notice a familiar smile, and this but very rarely. But where is the moral character that we ad-

pire so in the person represented? his serious or lively expression? his good disposition, that charms us? The orator, for instance; do you recognise him as the individual that impressed your mind so forcibly by his splendid flow of eloquence? Is it in this attitude that the general stood before the columns of his enthusiastic followers? No, they would scarcely recognise their leader in this unnatural position, if it were not for his uniform, and some unmistakable peculiarity of form or feature.

The first step that a photographer should take to obtain a good portrait, is to penetrate the numberless aspects under which he sees his model, and to ascertain the real type and character of the individual. It is thus alone that he is enabled to conceive an appropriate representation, and to choose the particular attitude and expression, as well as the distance, light, and accessories of the picture; and knowing these, he seeks to obtain the optical combinations requisite to express the result of his observations; in a word, he composes his portrait.

To compose a portrait is, therefore, to choose the best mode of representation, and to combine all the parts in view after this unique method. We will endeavour to explain this clearly by the following example:—Imagine a philosopher, who has passed his life in study and tedious research. The habit of constant meditation has marked his forehead, which rests on his hands, with deep vertical furrows; he is a man below the ordinary stature; his mind seems to have been developed at the expense of his body; he is calm and benevolent; his smile full of sagacity. These are the characteristics of his appearance in every-day life, when he is surrounded by friends and relations; his attire is naturally in keeping with his moral and physical being. It is very simple, and evidently a matter of very secondary importance with the wearer. Such is the man who desires his portrait. He will probably present himself to you in a costume for the occasion, which in no respect resembles his ordinary apparel. He will put himself in a stiff premeditated position, holding a large folio in his hand; but, preoccupied with his studied expression, he does not, in reality, read a single line. It is for the photographer to distinguish, under these borrowed expressions, the true and genuine character of his model.

Has he once made himself master of the personality of his subject, he will easily conceive the style in which he ought to be represented. The aspect of the portrait ought to awaken, independently of resemblance and the like considerations calm and serious ideas; it must possess simple attitudes, an interior light distributed in tranquil masses, with half shades, deep background, and a great sobriety of accessories. The head, being the seat of thought, presents a brilliant and luminous aspect. Such is the style to be adopted in this case; any other would be unlike and inappropriate, and would not produce the profound and powerful resemblance that we desire.

We must now proceed to combine the details and parts of our picture; but as it is the knowledge of the individual which has served to determine the style, all the details must be in precise agreement and harmony with it. If the photographer is efficient in the other principles of his art, he must thus obtain both a striking unity and a large and beautiful resemblance. Let us take another example, in a type of totally different character, namely,—a soldier, although very young, he has acquired the right to command; his carriage, looks, his entire bearing, express pride and courage; he has distinguished himself in the late war by acts of unusual daring.

The aspect of the picture is clearly indicated; life, passion, and energy must here be expressed. It would be absurd to wish to treat this portrait after the same method as the former one. The open air, plenty of light, no mysterious half tones, the body firmly posed, the gesture frank, without anything vague or uncertain,—numerous details, so scattered as to confuse the beholder; such would be the proper mode of treatment of the subject we have just described.

* From the "Æsthetics of Photography," in the "Universal Text Book of Photography."

We do not pretend to say that whenever we have to take the portrait of a learned man, or a soldier, it would be necessary to follow one of the styles that we have just indicated; on the contrary, we merely indicate the general character, leaving it to the reader to modify the aspect given to the picture, by as many differences as he finds in the individuals themselves. The severity of thought in the sage is tempered by enjoyment. The ardour and energy of the soldier is often accompanied by benevolence, and even tenderness. These different shades and degrees must, of course, be clearly expressed in the likeness.

That which strikes us first, in the individual, is his structure,—the width of his body in proportion to the height. It is necessary to take a sufficient distance, so that the difference of the planes and surfaces cannot interfere with these proportions. If the object be sitting with his knees and feet turned towards the lens, the head will be found to be on a level, upwards of a foot distant from that of the knees. This deformation would give the idea of a small head, a feeble body, and strong legs. The operator is, of course, always obliged, by the necessity of obtaining clearness in the field of his image, to take a sufficient distance. However, the distinctness of all the parts does not always indicate that the proportions are preserved. The perspective effect exists, but although correct in itself, it gives incorrect appearances to the reality. Thus, the artist would allow a considerable distance, if he wishes to preserve the exact proportions of his model; but, as his aim is not only to produce a correct, but also a beautiful representation, he will attempt, by varying the distance, to modify and embellish his model, without altering its character. If he wishes to take a good portrait of a person who has slender legs and a large head, he could shorten the distance a little, so as to diminish their ugliness, and give them a better proportion. Of course, the artist dare not do too much in this sense, for, unless he seizes the exact moment when the modification must not be continued, he will spoil the resemblance. What we say here with respect to the general proportions, is applicable to all parts of the figure. The disposition of the abridgments, in comparison to the distance, allows the artist to preserve the general character of the stature of the individual, and, at the same time, to improve it. It is impossible to foresee all the circumstances—but it is sufficient to explain these different optical effects to the photographer, for him to understand why so many portraits, in which the perspective is irreproachable, give the idea of individuals being little, or tall, although the originals do not in the least possess these proportions.

The position of the personage in the frame, and the disposition of the accessories, are also practical means of determining the stature of the individual, which the photographer should by no means neglect. Thus, the figure will appear much larger, if the head is placed near the top of the frame and plenty of free space left at each side. It will be increased and diminished in size as it is approached to the right and left edge of the frame, with a good deal of space above it. We shall, therefore, be liable to diminish the resemblance of a portrait considerably, by not paying sufficient attention to these effects, and deprive ourselves at the same time of modifying and embellishing, to a certain extent, the proportions of the model.

The choice and disposition of dress have a great influence on the proportions; and close fitting light cloth garments increase the dimensions of the head, the hands, and the extremities; a flowing and ample dress, on the contrary, renders these parts little and delicate.

Again, by the direction of the light, and the distribution of the lights and shades, the artist is also able to increase the character of the proportions which constitute the resemblance of the individual, giving, at the same time, a new beauty to the likeness; he will render certain parts thinner by plunging them into the half tone, or by burying the outline in the shade; he will deepen and augment other proportion, by surrounding them with light. Thus, he would

increase the size of a head that appears too small, by throwing the light on the face; and diminish the size by choosing a tint that would throw one half of the face into the shade. In general, a dark background serves to make heads appear small, and a light one increases the size. Backgrounds of a middle tone, on which the lights and shades are equally developed, are the best qualified to give an idea of the exact dimensions.

It is by all these means, combined, that the image obtained presents this first and so important an aspect, resulting from the stature of the model, and which causes it to be recognized at the first glance by the masses that it offers to the eye, and quite independently of all detail, or peculiarity of feature or dress. It is also by these means that the artist is able to embellish the proportions, without passing the limit of resemblance.

A question which seems to attach itself, naturally, to the one we have just treated, is that of the real size to be adopted for the photographic portrait. Without doubt, the importance of the subject ought to serve as a guide. It would scarcely be proper to give the same dimensions to the portrait of a celebrity, as to that of a little girl playing with her doll. However, the difference ought, above all, to depend on the mode of treatment of the picture, and on the disposition of the scene, which the character given to the subject presents. It is in the importance of the aspect, and in the gravity of the lines, that the artist ought to seek the character, and not in the dimensions. The Greeks and the Egyptians have expressed the majesty of their gods and heroes, in bronze, or clay images, even less than an inch in length. The photographer, in the question of real dimension, must, above all, consider the destination of his picture. If it is to be placed in a very open position, he will increase it in size to that of life, or even beyond. If, on the contrary, the portrait is destined to adorn an ordinary apartment, or a boudoir, he will make it of much smaller dimensions. Should it, however, be destined for a brooch or locket, the likeness must possess æsthetic beauty and majesty, provided the subject will admit of so elevated a style. We scarcely need add, that the methods of augmenting the size render all dimensions possible to the operator, whatever the reduction may be that the original image has undergone, on account of the choice of distance.

The portrait may represent the individual either in full length, in half size, or merely the bust; portraits are even taken with the head alone; lastly, one may group several persons in the same portrait. It is evident that the artist should, by no means, be governed by chance; and that here as well, the rules of the art must guide him in his choice.

The full length portrait is the most suitable of any to express the complete resemblance of the individual, from the expression of the physiognomy down to fine attitude and proportion; but what difficulties the artist has to overcome, before he is able to take a perfect likeness, with regard to resemblance and beauty!

In the full length portrait, we are not to be guided only by the inflexions of the neck or the arrangement of the arms; it is the play of the muscles and sinews that determines the general situation of the other parts of the body; the visible position of the feet does not hide, from the eye of a beholder, the absence of equilibrium in the movement. However excellent the inclination of the head, or the disposition of the shoulders and arms may be, if you make the slightest fault by giving an unlucky turn to the knee, or by placing the foot in a bad position, you destroy the whole logic of the position. Nothing is easier in such a portrait than to fall into awkwardness, without resemblance, or even into ugliness. It is, of course, apparent that the difficulty must be increased by the necessity of producing a resemblance.

The half size, or half figure portrait, ought to give a nearly perfect idea of the individual; it shows the attitude of the body, and indicates the position of the lower extremities, which are absent. If the model is standing erect, the frame will pass about the middle of the thigh; if the model is

sitting, the knee and part of the leg will be visible. If this be not so, the pose would be bad, and present to the eye an unpleasant incompleteness; for the same reason, the hands and arms should be full in view.

In the bust portrait, the person is represented as far as the chest, without either the hands or the arms. In this case, the head is everything, and the bust is merely represented to sustain it, and give it its true size and proportion. If the bust be too large, the eye of the spectator naturally desires the arms, hands, &c. One must, however, be very careful not to fall into the opposite excess, by giving too little of the bust, as the head would appear quite out of its proper proportion; the nature of the model is the surest guide as to the importance to be given to the bust. The modifications that you can obtain, by means of contrast, are important aids for obtaining resemblance and increasing beauty.

It follows, from what we have just seen, that the head should never be represented without the bust. The effect of such a portrait is altogether devoid of correctness and unity, and does not offer a single point of comparison by which the spectator could judge of the proportions of the head with respect to the rest of the body; a matter of much importance, as this is one of the most striking characteristics of the individual.

(To be continued.)

STEREOSCOPIC MANIPULATIONS IN THE FIELD.*

THE plates which I use for the reception of the stereographic negative are seven inches long by three inches and a half wide. By having the plates somewhat larger than absolutely required, allowance is thus made for any defect that might be visible on the ends or edges, which are more liable to such than the central parts; for if it should happen that the glass corners of the plateholder have not been thoroughly cleaned before the insertion of the sensitized plate, or that the silver solution has not been allowed to drip off after it has been withdrawn from the bath, the fluids in the corners (especially if these are cemented and not wholly of glass) becomes readily decomposed by the lac or resin with which the pieces are cemented, and by capillary attraction arises along either end, and moves on the lower horizontal edge, and produces a reduction of the silver in these parts, as if the film were marbled.

Such an occurrence is very troublesome, and ought to be avoided, and can be avoided in general as follows:—

Clean the glass corners thoroughly every time before the introduction of a new plate; allow all extraneous silver solution to run off into the bath before the plate is entirely removed from it; finally, with a piece of blotting paper or an old rag, carefully remove all fluid from the posterior surface of the plate and corners. In the last operation it requires great caution lest any part of the protuberant portions of the blotting paper or rag should, by the quick motion, lap round the edges, and thus disturb the collodion film. As soon as all extraneous silver solution has thus been removed (and, of course, all these operations have to be performed in darkness), it is placed in the plateholder and inserted in the camera.

I need scarcely remark here that the interior of the camera must be quite dark; in field-work, that is, outdoor-work, a mere pin-hole would allow sufficient light to penetrate so as to destroy the best negative by fogging the whole surface; and not only must the interior be quite free from the ingress of light, but all the parietes must be stained or coloured of a dead black, as also the inner surface of the tubes containing the lenses. The greatest care, in like manner, is required in drawing out the slide and again in replacing it, after the collodion film has been impressed with the image, in order to exclude every ray of diffused light. It is well, therefore, to throw over the upper surface of the camera a large black cloth, so that, in drawing out the slide, the amateur seizes it together with the cloth, and draws both up or sideways at the same time. The focussing cloth, as an auxiliary in this respect, is left on the posterior end of the

camera to keep out all light that might penetrate through any crevice in the grooves in which the plateholder slides. By never omitting such cautious manipulations, many an inconvenience and unexpected disaster will be avoided, which are frequently attributed to the collodion, the bath, or the developer.

Another caution in landscape photography or stereography is to avoid exposing the plate too long; if the lenses be good ones, that is, well corrected aplanatically and achromatically, four or five seconds, for a lenticular aperture of an inch and a half and a diaphragmatic opening between the lenses of half an inch, will be found, in general, sufficiently long, and frequently much too long. Stereographic negatives in the field seldom require more than two seconds with such a stop; in fact, sometimes when the weather is very fine, the air quite clear and totally free from any haze, a quarter of a second will produce a very respectable negative. Let the circumstances be as just described, and let a plate be exposed for thirty seconds; a picture will probably be produced that might mislead the beginner and induce him to lengthen the time. On the contrary, let the student begin with one second; if the picture comes out quite distinctly in all its parts, with a proper contrast between the lights and shades, and containing, besides, the middle tints, the time, probably, will be quite sufficient, especially if the negative has to be intensified afterwards. Where the proper opacity is to be developed by the first operation, a longer time is required. In this case a very weak developer must be used, otherwise the development will be quite unmanageable; as soon as the slightest appearance of fogging in the high lights becomes visible, the plate must be instantaneously washed. By shortening the time, the operation of development is entirely within the control of the artist; and the intensification afterwards can equally easily be regulated. The process of intensifying can be performed either immediately, that is, before the plate is dry or any time afterwards. It seems to me to be a good practice to perform this operation after the labour of outdoor work, at a time when there is no hurry, and where there is every convenience. For such purposes the edges of the negatives have to be varnished by running the side of a glass rod, dipped in varnish, all the way round so that the collodion film becomes covered in width of one-tenth of an inch with this glutinous and protecting substance. The varnish is then allowed to dry spontaneously. So treated, the plates can be hoarded away and strengthened at any convenient opportunity. Supposing the day and moment have arrived when the negatives have to be intensified. The plates are immersed in soft water and kept there for at least half an hour; in this time the film has become softened and impregnated with water, and is thus rendered suitable for the action of the intensifier.

INTENSIFYING PROCESS.

It is supposed that the negatives are suitable for intensifying and have been thoroughly washed, and, if dry, thoroughly soaked. If there be no middle or intermediate shades in the given negatives it cannot be expected that the intensifier will produce that which already has no existence. The office of the intensifier is to *thicken and darken* the shades and half shades that have already appeared under the developer, but not to produce shade and half shade. The process, therefore, is twofold, consisting in *thickening* the existing deposit, and then in *darkening* the thickened deposit.

TO THICKEN THE ACTINO-SILVER DEPOSIT ON THE COLLODION FILM.

The shades receive a deposit, as it were by galvanic action, in various ways. In the first place, if we pour on the wet surface of the negative a solution of bichloride of mercury quickly, so that the action can commence simultaneously in every part of the negative, it will be found that the shades increase in opacity and become more and more dense.

Secondly, throw the plate with a dilute solution of the red iodide of mercury dissolved in iodide of potassium until the same result is obtained. (Iodide of mercury can be bought, or prepared as follows:—Drop a solution of iodide of potassium into one of bichloride of mercury as long as a red precipitate is obtained; as soon as this precipitate has subsided, pour off the supernatant liquid, wash well and several times with water, and again pour off all the liquid above it. Now drop upon the precipitate a saturated solution of iodide of potassium until the red-coloured substance is entirely dissolved, and the solution

* *Humphrey's Journal.*

† Silver-wire corners are almost universally used in this country, which prevent the trouble referred to.

has become transparent. This is the solution in question, which can be diluted *ad libitum*.

Thirdly, the plate may be flowed with tincture of iodine, or a solution of iodine in iodide of potassium, until the shadows become slightly and uniformly yellow and opaque. In addition to these method others might be enumerated.

TO DARKEN THE THICKENED DEPOSIT.

The film, thickened with bichloride of mercury can be darkened with either ammonia, sulphide of potassium, sulphide of ammonium, pyrogallic acid and nitrate of silver, &c.

The other films can be rendered dark-coloured by flowing the plates with either pyrogallic acid and nitrate of silver, the protosulphate of iron and nitrate of silver, or with an alkaline sulphide.

It is not absolutely necessary that the shadows should be black in order to produce a good negative; the thickened film produced after development either by a solution of protosulphate of iron and a few drops of nitrate of silver, or by that of tincture of iodine, or solution of iodine in iodide of potassium is quite as efficacious in producing a good print, whether blackened or not, the film being of that spectral colour which is as impermeable to light as black.

It is difficult to say which mode is the best; each operator has his favourite method; and I prefer intensifying with pyrogallic acid and nitrate of silver, first thickening, where I think it is necessary, with a solution of iodine in iodide of potassium. In all cases of intensifying it is to be recommended that the solutions be dilute, otherwise the deposit will be quite granular, and will render the negative unfit for printing by the production of pictures covered, as it were, with the small-pox. A soft and uniform deposit can be obtained only by dilute thickening and intensifying agents.

Supposing the stereoscopic negative is sufficiently intense, and in other respects perfect, it is dried and varnished, and again dried. By means of a diamond, it may now be cut in two in the middle. From either half, reckoning from the middle, a portion or slip is cut of two inches and a half in width. These two slips, which contain the right and the left side picture, are placed upon a piece of glass five inches long and four inches wide, in such a manner that the left slip is placed on the right side and *vice versa*. The two slips are held in their place, and in contact in the middle, by means of gummed narrow tape along the upper and lower edges and the projecting edges of the underlaid glass. Prints taken from a negative so arranged require no transposition, which they always do if printed from an uncut negative.

A SIMPLE METHOD OF TRANSFERRING THE COLLODION NEGATIVE FILM UPON PAPER.

BY DR. SCHNAUSS.

THE chief fault in the collodion process is the fragility of the glass. Many beautiful glass positives have thus been destroyed; and this may have probably led to the invention of the Pantotype process. Unfortunately no substitute has yet been introduced for glass negatives, although there has been no want of propositions in this direction. Such a substitute is quite a desideratum; for the great pressure in the printing frames is continually exposing the negative to fracture, especially if plate glass is not always used for the reception of the collodion film. Besides this, to the tourist a large quantity of glass plates is quite a burden. To obviate this inconvenience I have for some time been instituting a course of experiments, in order to find means of transferring, by a simple and trustworthy method, the negative collodion film to paper. These collodion paper-negatives naturally can be preserved and transported much more conveniently than glass negatives, and yield, whether waxed or unwaxed, sharp and intense prints. If the papers are not to be waxed (and this is not at all necessary with fine paper), this circumstance has to be taken into consideration during the intensifying of the negative, so as not to carry it too far; for the opacity of the shades is much increased by the paper.

The preparation of the paper is simply as follows:—A half or a whole sheet of paper is pinned smoothly upon a horizontal board, and smeared as uniformly as possible with a hot solution of pure gelatine of so strong a consistency as to congeal when cold into a firm film. It is better not to cut the paper into too

large size, but rather into pieces suitable for the different sized glasses used, because of the facility of covering the surfaces more uniformly with gelatine than when whole sheets are employed. Finally, the boards with the gelatinized papers upon them are reared perpendicularly to dry. All creasing of the paper must, as far as possible, be avoided, because the gelatine collects more abundantly in the creases. As soon as the sheets are dry, they are placed in a portfolio and subjected to a slight pressure, in order to preserve them as smooth as possible.

The method of transferring in question I have as yet practised with collodion films whilst they were still wet, and proceed as follows:—

I use a good negative collodion of about the consistency of the ordinary transfer-collodion in the Pantotype process. As soon as the picture appears, by means of the iron developer, sufficiently intense for the purpose, although still too weak for direct printing, no further intensifying is required with pyrogallic acid. The latter expedient is required only when the solutions are newly made, which, it is well known, do not yield intense negatives. After a few experiments it is easy to determine the degree of intensity most suitable for the purpose. In all cases the picture must exhibit middle tones and be free from all fogginess.

This method is best adapted for transferring portraits where the heads are not over small, on quarter, half, or whole plates, as well as landscapes and architectural pictures on whole-sized plates or larger.

As soon as the picture is fixed, it is well washed and afterwards flowed with the following solution:—

Hydrochloric acid	1 drachm
Alcohol	1 "
Water	2½ ounces.

Which is kept in motion on the surface for a few minutes. The negative is then again well washed. In the meanwhile a piece of the gelatine paper, of a size somewhat smaller than the glass, has been placed upon water with the gelatine side downwards, taking care of course to avoid bubbles. In winter lukewarm water may be used.

The glass negative is now placed on the table, with its collodion side upwards and still quite wet; upon this surface the gelatine paper is removed from the water, allowed to drip for a moment, and then carefully placed, gelatine side downwards, on the collodion film so as to avoid all bubbles of air between. The requisite manipulation for this purpose is known to every photographer, being similar to that required in the transference of positive pictures.

As soon as the protruding edges of the collodion film have been folded back upon the paper, the whole is reared on one end for a few minutes, so as to allow the fluid to flow off from between the collodion and gelatine films; after this it is placed in a printing-frame with a few folds of blotting paper on the back, and submitted to gentle pressure, but only for a few minutes, otherwise the picture would dry, and then it would be impossible to remove it from the glass. Hereupon the gelatine paper is raised at one corner to see whether the film adheres to it. If this be the case, a few drops of water are allowed to fall between the glass and the film, and the glass is held obliquely and in such a direction that the water can flow where the film rises from the glass. If the operation is successfully performed, the transferred picture is hung up to dry.

Where the papers are required to be waxed, they are placed with the collodion side downwards on a warm copper plate, and then carefully smeared with a mixture of wax and hart's tallow. It is finally pressed, whilst still warm, between the folds of fine bibulous paper, in order to remove all the superfluous wax. The wax-mixture is best prepared according to Martin's recipe by melting together three parts of white wax and two parts of purified hart's tallow. After the mixture has been intimately stirred together, it is poured into a cylinder of cardboard closed at the lower extremity with a cork. When cold it can be removed from the mould like a candle without a wick, with which the warmed paper negative can be smeared by a gentle pressure.

By this process very good and satisfactory results can be obtained, of which fact those who attend my course of instruction have often had an opportunity of convincing themselves. The prints are just as fine as those from glass negatives, especially if the paper has been waxed. To no indeed they appear to possess an advantage over the latter owing to a peculiar softness with which they are endowed.—*Photographisches Archiv*.

Proceedings of Societies.

THE AMERICAN PHOTOGRAPHICAL SOCIETY. FORTY-NINTH MEETING.

THE Society held its regular meeting for June, on Monday, 8th inst., at the University; Professor JOY in the chair; Mr. N. G. BURGESS was appointed secretary *pro tem*.

The minutes of the last meeting were read and approved.

A letter was received from the president, enclosing a communication from Mr. John Johnson, of Saco, Maine, on the growth of plants under different coloured glasses, and giving the result of some experiments.

Method of Preserving Negatives, including Varnishing.—This being the special subject for the evening.

Mr. HULL inquired what was meant by preserving negatives?

Mr. BURGESS: I understand to keep them from becoming useless, which they will, if not preserved. Sometimes we preserve them by varnishing, sometimes with gum arabic; they can be preserved by mica, or in half a dozen ways.

Mr. CRUM: Perhaps there is not a subject fraught with more interest to photographers than this. As every practical photographer knows, negatives are the subject of a good deal of trouble and anxiety. We are told the best way to preserve them is to put them in grooves, after being finished, lay them away, keep them from the dust, &c. But, we have found, by using various varnishes that the negative will depreciate, and lose not only vividness and transparency, but intensity. Some varnishes, instead of being a benefit to negatives, are a curse, because they become freckled and streaked. The cause, I am unable to determine. The plan I adopt in my process is to dry them as soon as convenient, and varnish them immediately.

Mr. BURGESS concurred that this was one of the most vexatious matters connected with the art. Frequently they wanted to preserve negatives more than a year after being taken. If not properly varnished they would spoil. Great care should be taken to wash them clean from the hyposulphite, or they would be destroyed; but the greatest trouble arose from the varnish. He had, in one establishment, seen them all, three different kinds of varnish, but all the pictures were destroyed. There was a "flint varnish," manufactured by Mr. Anthony, which he found to work well.

Mr. HULL had used equal parts of seedlac and shellac, and warmed his plate well. Occasionally, if the varnish was brittle, he added a little Canada balsam. This he had never known to fail. He generally took seedlac in an ordinary glass globe, put in alcohol, boiled down, by adding seedlac with shellac until he had quite a syrupy mass, which he kept, diluting at a time enough to last a couple of weeks.

Professor SEELY: Is it the common red shellac you use?

Mr. HULL: No; I use a good quality of bleached shellac. About a month ago he had occasion to use a negative which was laid by for a year, then in perfect condition; when taken hold of, it was all broken up in many lines and long blisters. But this instance he attributed to imperfect washing.

Mr. BURGESS inquired if any one had heard of the process of printing with mica, and not varnishing at all? He had read of its being done in England. It was true all negatives printed better without any varnish, if it could be done, the varnish changing them to some detrimental degree. Some skillful man had used a thin layer of mica; but that was attended with great difficulty. Some have used gum arabic, which does not affect the picture at all. It is put on before the plate is dry. But he had put gum arabic over them, and let the picture stand two months, and it surely spoiled. It was only proper to use it when they wanted to use the glass in a short time. There was certainly a great defect in the varnishes used.

Mr. HULL said one of the most successful practical photographers in Philadelphia kept his negatives by using albumen in solution. One of the troubles in regard to varnish arose from the fact of its being put on too thick; it should be used as thin as it could be, and have a thin surface.

Mr. TILLMAN judged that one of the difficulties would be, that putting on a liquid on such a fine work as a negative must interfere with the picture. It struck him (and he threw out the suggestion for practical photographers) that it would be better to put on the varnish in the shape of vapour, at first

thus obtaining a fine coating that could not be had in the usual form.

Mr. CRUM said it had occurred to him whether the fault was attributable altogether to the varnish or to some other process in making the negatives. Out of a large collection he had bought he found some preserved remarkably well, fine, very intense, clear, and transparent, and apparently as good as the day they were varnished and laid away. Others, with apparently the same kind of varnish were very much affected, rusty, and having a tendency to peel off, spotted, and badly scratched. Whether this was owing to bad handling before the negative was laid away, or was attributable to the varnish, he was not able to say, but among those piled away he had found some of the worst, while among those piled up promiscuously some were very fine. Some varnish, when put on the plate, after being heated, will dry very unevenly, and notwithstanding all precautions he found the negatives badly spoiled. In the last number of the *Journal of Photography*, he saw that a correspondent inquired in regard to this very difficulty. He thought, so far as his limited experience went, that it was owing to the breath depositing moisture on the plate when varnishing.

Prof. SEELY believed that in respect to varnish we had, in this country, been more fortunate than our neighbours in Europe. For the first four or five years of collodion working, the varnishing question seemed to be the most important; there were any quantity of inventors of varnish, and probably there was nothing known in that way that was not used. The chloroform amber varnish was invented, and the difficulties supposed to be removed. But amber varnish was found not to work well in this country. Here copal spirit varnish came into use at the first, and continues still to be used. It was better at the start than it has been generally made since. For a number of years it was the only varnish used, according to his recollection. Then some worthy gentleman discovered that shellac was nearly as good, and that was put into use. Later, benzole was used as a solvent, but he did not know of any varnish, in this country, where benzole was used, that was good for anything. He thought the varnish sold for "negative varnish," by respectable manufacturers, was all right, and that some of the imperfections charged upon the varnish was with the individuals themselves. He had learned after years of experience, and he had been told that one of the most difficult things to do was to lay varnish evenly. He had taken some thousands of prints from a single negative made years ago, without deteriorating the negative, and it was perfect enough at this day. He had often seen gum arabic used, but he thought albumen a good deal better. One of the former difficulties with varnish was that it was used too thick.

Mr. HOLZ gave the proportions of the varnish used by him as six ounces bleached shellac, four pints alcohol, and three ounces gum sandrac, filtered carefully through paper. This was a good varnish, still he found that it did not always answer the purpose. He did not think it would be well to print negatives without varnishing, for we could not get any wear or tear out of them. Pictures which were too intense were benefited by the varnish.

Brass Toning.—The subject of brass toned pictures having been introduced,

Mr. HULL said that Mr. Thompson did not claim to tone his prints with brass entirely. He did not use exact proportions—he merely used brass in connection with gold to a very trifling extent. Mr. Thompson made excellent prints, but it was by admirable manipulation.

The members expressed a good deal of incredulity as to the feasibility of toning with brass.

Mr. TILLMAN thought that, until some members made experiments, a discussion on the subject was unprofitable.

Polar Expedition.—The following was, on motion of Mr. TILLMAN, adopted:—

Whereas, The members of the Photographical Society have heard, with great satisfaction, that Mr. Washington Peale is about to accompany Captain Hall upon another Polar expedition; therefore,

Resolved, That this Society will take an active interest in the scientific objects of the expedition, and will especially contribute towards the photographic branch of the service, by any means in its power.

Resolved, That this Society hereby solicits contributions of money and photographic materials, in aid of the undertaking.

Resolved, That the Society wish Mr. Peale, and the other

members of the expedition, God-speed and a safe return, from the perils of the Polar seas.

Two subjects were designated for the next meeting: Lenses, and the Influence of Coloured Glass on Vegetation.—*American Journal*.

FORMIC ACID.

BY Z. J. GODIMUS.

Two acids are now being put to the proof by photographic chemists: they are formic acid and tartaric acid. We give the result of experiments made at different times during the last two years. We shall first notice formic acid; especially as it will give us an opportunity of recalling to mind some general ideas susceptible of giving a better comprehension of the nature of this photographic product.

Chemists have at first contended this acid with acetic acid. The first has a formula of $C^1 HO^1$, HO , and the second and $C_1 H O_2$, HO ; they can obtain both from the reaction of the chemical elements of alcohol upon very divided platinum; oxidation takes place at the expense of the oxygen of the atmosphere. Formic acid and acetic acid enjoy, besides, analogous properties, both physical, and chemical, and organoleptic. We can then understand the error of our predecessors in science. We pass over in silence the two scientific developments, regretting we cannot give them, compelled as we are to keep to the practical side.

Formic acid ($C^1 HO^1$, HO) is thus named because it was first obtained by distilling ants with water. The liquid, collected in a receiver, was saturated with carbonate of soda. ($Na O, CO^2$): afterwards evaporated to dryness, then distilled again, the salt dissolved in a liquid composed of equal parts of sulphuric acid and water (by weight). Such was the first preparation.

The acid thus obtained was monohydrated, as the formula indicates. It is difficult to procure it in the anhydrous state, and as we cannot perceive to what an anhydrous combination will lead us when we introduce this acid into an iron developing solution, we ought to give the plate less exposure in the camera. This monohydrated acid is liquid, colourless, and very corrosive: it blisters the skin instantly. It boils at $212^{\circ} F.$, and in every condition is volatile, very acid, with a vivid, penetrating odour. It is very greedy of oxygen, and instantly reduces the salts of gold, silver, and mercury. United with concentrated sulphuric acid at the ordinary temperature, it is converted into water and oxide of carbon, which essentially distinguishes it from acetic acid.

We have actually arrived at a great diminution in the time of exposure—that is to say, where we used to give four minutes exposure we now give only one minute, and obtain as good results. We always take care to add our formic acid to our developing solution only at the moment of using it, and the liquid dowing off the plate was rejected. Lastly, we made use of monohydrated formic acid. The following is the formula employed:—

Purest Distilled Water	100 parts.
Refined Protosulphate of Iron ...	5	"
Monohydrated Formic Acid ...	$\frac{1}{2}$	"

We entertain no doubt that, all the conditions being well observed, this bath will permit of the developing instantaneous pictures which have been taken in a good light.—*Bulletin Belge de la Photographie*.

Photographic Notes and Queries.

NON-ACTINIC WEATHER.

DEAR SIR,—May I inquire of your numerous readers, whether, during the past and present week, they have noticed any peculiarities in the state of the atmosphere; as with us, at Ross, from 10 o'clock a.m., until 5:30 p.m., we can get no pictures without exaggerated exposures and an immensity of intensifying.

Many may urge the bath, the collodion, the developer, as being in fault. I would state that the same occurs with baths newly made with Sutton's recrystallized nitrate; with Johnson and Mathey's samples of silver added to which the baths that on Saturday last gave brilliant results, the same now give pictures, it is true, but they are flat and poor. Of collodions I have the same results with Ponting's, Sutton's, Mawson's, Horne and Thornthwaite's, (by the bye their collodion is A 1.), and Perry's—the same with many of these mixed. Whether the developer be 10 grs. or 50 grs., whether with acid, without acid, or with formic acid, the results are precisely the same.

There seems to be a want of electricity in the air: many around us are complaining of pains and giddiness in their heads.

Now, I should like to know whether such is felt and found in other parts of England; whether at the seaside or only inland? Perhaps some of the numerous readers of your widely published journal would give us their ideas upon the matter.—I am, dear sir, yours,

W. H. WARNER.

Ross, 8th July, 1863.

Miscellaneous.

IMPURITIES IN THE NITRATE OF SILVER.—Certain photographers are very apt to blame the nitrate of silver as soon as they get into trouble. They should be cautioned against this. We can safely say that the nitrate of silver sold by our leading stock dealers is faultless; and what is true of nitrate of silver is equally so of all other photographic chemicals. Some photographers, however, supply themselves at the country drug stores, and for the benefit of these we will say a few words of the impurities ordinarily found in commercial nitrate of silver. Crystallized nitrate of silver may be acid, and when acid, it contains often a small quantity of organic matter. A bath made with such an article will be apt to work foggy. The test for acidity, everybody knows, is litmus paper. When this turns red in the solution, add to it some oxide of silver, and set it in the sun for one or two hours. Then pour off the clean part, filter and add a drop or two of nitric acid. Fused nitrate of silver gives baths which will only work clear after adding several drops of diluted nitric acid. Nitrate of silver may be mixed with nitrate of potash, or other alkaline nitrates. In this case there is a loss in quantity only, as the presence of these substances does not unfit the bath for photographic operations. Pure nitrate of silver precipitates its weight of iodide of potassium. This furnishes a simple means of testing, if it contains the required quantity of silver. Proceed as follows:—1st. Dissolve 40 grains of the salt to be tested in two ounces of water; 2nd. Dissolve also 40 grains of iodide of potassium in two ounces of water; 3rd. Dissolve 16 grains of nitrate of silver, which you know to be pure, in two ounces of water; 4th. Mix the first and second solutions together; a yellow precipitate of iodide of silver will be formed, which will settle, leaving the liquid slightly troubled, it containing little yellow iodide of silver in suspension. An addition of the third solution will clear up the liquid. When only a few drops have to be added to accomplish this result, the nitrate of silver may be considered pure. But when larger quantities are added, without clearing up the liquid, the salt is probably mixed with some other nitrate. To determine how many grains of nitrate of silver are short, add one drachm at a time of the third solution, shaking, after each addition until the liquid becomes clear. The number of drachms to be added will represent the number of grains of nitrate of silver short.—*American Almanac of Photography*.

Talk in the Studio.

PHOTOGRAPHY AND FORGERY.—Pietro Regnoldi, an Italian, was recently brought before the Lord Mayor, charged with causing to be forged a one-guilder note, with intent to defraud the Emperor of Austria. It appeared that on the 18th ultimo the prisoner went to the residence of Mr. McQuire, of 4, Aldgate, photographer, about seven o'clock in the evening, and asked to

sent a specimen of phot. graphy. Several were shown him, with which he was apparently satisfied, but he left without having his likeness done, promising to call next morning, which he did. Two portraits were then taken of him, after which he asked M-Quire if he could copy works of art, and, when answered in the affirmative, he expressed much pleasure, saying that he had heard a very favourable account of him, and he would give him some work, which would bring him in lots of money. He then produced a one-guinea note, and asked the photographer whether he could take an impression of that upon glass, so that it could be reproduced. M-Quire said he could. He then left the note in the possession of the latter, charging him on no account to let any one see it, but when it was prepared to give it back to him, and he would have 1,000 struck off, and if they were successful they would do some more of greater value. He also asked M-Quire if the paper could be procured in London, and, on the witness telling him he did not know, he said it was not of much consequence as they could get it abroad. M-Quire then communicated with the police, but in the meanwhile he photographed the guinea note with which the prisoner was very pleased, and gave him six napoleons, together with a five-guinea and a ten-guinea note, which he wished to be photographed in the same manner, and, when they were all to be completed, he directed his (as he thought) accomplice to get the whole three engraved, so that they could at once commence to strike them off, telling him, at the same time, that when they were done they would proceed to the Continent together, where they could make their fortunes in six months; after which they might retire to America or Australia, where they could live a life of ease and pleasure without fear of discovery. These anticipations were, as the prisoner thought, just about to be consummated, when he was taken into custody. On his person several guinea notes were found, together with forty-two golden napoleons. The prisoner was again remanded.

GLASS BATHS.—We have received from Messrs. Claudet and Houghton a sample of a new form of glass bath, which is, in several respects, superior to those hitherto made. One essential improvement consists in a lip from which to pour the contents without spilling, an operation almost impossible with the ordinary straight-sided vessels usually made in glass. The lip does not in any way interfere with the application of the water-tight cover, as there is no depression of the top where the lip projects; the whole is ground level, and may easily be fitted with the cover. The bath is better made and stronger, especially at the bottom, than most glass baths we have seen.

INSTANTANEOUS DRY PLATES.—We have received from Mr. Hurst, of Mirfield, some few slides taken on plates prepared by a modification of the tannin process, which is manifestly very rapid. Two of the plates have had instantaneous exposures. A cow grazing in the foreground has not moved, a boat is being rowed down the stream, foliage in the mid-distance is made out, a distant town well defined, and the whole crowned with good clouds. A little longer exposure would have been better, but the result is remarkable for dry plates. Mr. Hurst employs Dallmeyer's new stereo lenses, and probably a large aperture has been used. Mr. Hurst, speaking of the slides, says:—"Two of the views of Knaresborough were exposed instantaneously; they are not good pictures, but they show the sensitiveness of the plates in giving even details of foliage at the same time as clouds. Had they been exposed at the seaside with water and sky only to be impressed, I have no doubt they would have been perfectly successful. Most of the plates had been prepared some weeks and were not developed (even the instantaneously exposed ones) until 6 or 7 days after exposure."

To Correspondents.

PHOTOS.—We do not recommend you to adopt the hypothesis, but if you do, it, after carefully reading it, is of few hours' bearing. 2. The advantages claimed for the saccharin process are that it is a titanic process, and that it gives a different and more distinct image. See page 2. 3. Precipitate the cover as chloride with common salt. 2. Tanning of albumen prints is effected with water. 4. A mixture of soda, Bichromate, and neutral tint will be found equally to answer the purpose. Of course it is necessary to match the colour of the print, and a little gum water will be found to mix with the colour to give it a little gloss, and then wash when dry. 3. The tanning baths containing lime generally give a better result. 4. **J. BARNEZ** says:—"Can you kindly inform me how to remedy hardiness

coming from the bath. I had a negative bath which gave beautifully soft pictures for two months. It then gradually began giving pictures harder and harder day by day. I have tried every known remedy, making it alkaline with oxide of silver and tanning for ten days, tried it faintly acid, very acid, neutral, still hard pictures, strengthened it, weakened it, always with the same result, overdarkness in the high lights. I use a strongly bromized collodion, the usual iron developer, intensifying with citric acid and iron. On first developing the latent image the high lights shoot out, and the half tints only make their appearance after prolonged development, whatever the exposure may be. As I never was so troubled before I should like to know the probable cause and the remedy if any. Up to the present, I had never had a bath 'out of order' longer than 20 or 30 minutes." The case described is a complete anomaly: for a bath to give precisely the same class of pictures whether it be alkaline, neutral, or acid, and with whatever exposure to give hard pictures with a highly bromized collodion, is an experience we have never met with. Using oxide of silver is sometimes very deceptive. If it be not fully precipitated it will sometimes remain a very long time in the bath without injuring it. Although its use is the most philosophical plan of neutralizing the bath, we now generally recommend the use of bicarbonate of soda as giving less trouble and more certainty. Again, what acid did you use? What acid did the bath originally contain? If acetic acid, the addition of oxide of silver would form acetate of silver, which would readily account for the results you describe. Are you quite certain it is the bath and not the collodion which is in fault?

J. H. B. KERR.—The bleaching in the prints considered is, doubtless, due to excess of free chlorine. When the tanning solution is required to be used soon after mixing the portion of chloride of lime added should be very minute. Age always, up to a certain extent, appears to improve the lime bath, but what is the exact process which goes forward to produce the improvement we are uncertain. The process with carbonate of soda, as described by Mr. Elliot, is very excellent, but does not give quite the same tones as the lime bath.

P. T.—Paper prepared with bichromate of potash and gelatin, or any similar organic body, when exposed to light, first assumes a brown tint, and then a greenish hue. Neither of the colours obtained have in themselves any pictorial value. By a combination with other metallic salts, however, a variety of tints may be obtained. You will find some interesting details in a paper by Mr. Hannaford, on page 341 of the third volume of the PHOTOGRAPHIC NEWS. The chief value of the bichromates is found in the various carbon and photolithographic processes, where the fact that a compound of organic matter and a bichromate is rendered insoluble by the action of light, becomes of the highest importance. 2. Water colours, with a little gum or albumen added, should be used for touching out spots in albumenized prints.

J. S. V. L.—The chief photographic fault of your specimen is a little under-exposure of the negative, and the chief artistic faults are a pale ground in the position and a too "loud" or obtrusive background.

A. STREKER.—It has been asserted by some authorities that the use of bromo-iodized collodion in a silver bath suits it for subsequent use with simply iodized collodion. We have never found any such datum in the bath, but if we did we should not regard it as a matter of consequence, for we should never think of using other than bromo-iodized collodion, except for special experiments.

T. INGLEBY YATES.—In our recent article on altering the intensity of varnished negatives, we explained the method of reducing intensity. It consists in continuing the action upon the varnished film, of the alcoholic solution of fuchsine, until the deposit is inverted into white, or light yellow instead of silver.

LES. DART.—Procure a blank form provided at Stationers' Hall, and send for a penny a fillip with a brief, but intelligible and characteristic description of the picture; proceed to the Registering Office, and pay one shilling for each photograph to be registered, or forward the form with fillip in place for each photograph, to our publisher, who will undertake the trouble for you. You will find full information in our last volume, and also in the present year's PHOTOGRAPHIC NEWS ALMANAC.

G. F.—The excessively acid state of your bath is, doubtless, the cause of the film leaving the plate. A more adherent sample of collodion may prove a remedy; but you had better direct the amateur.

M. T. H.—Print deeper and tenebrous, if your air-bark tones. Your vignette pictures are too formal in the graduation of white, a more natural effect will be visible in glass. To vignette well requires the use of care, taste, and colour well.

J. H. INSKIP.—Your advertisement arrived too late for our last. Several correspondents in our next.

Photographs Registered during the Past Week.

- MR. R. BURTON,** 2, Crampton Quay, Dublin, Photograph of Mr. F. Robson (comedian) and Mr. F. Robson, junr.
- MR. H. PENN,** Birmingham, Photograph of the Right Hon. the Earl of Dartmouth.
- MR. A. S. WATSON,** 2, Regent Road, Great Yarmouth, Photograph of Rev. —Bolton. Photograph of Frank Workshop, Esq.
- MR. JAMES BURKE** 13, Upper Sackville Street, Dublin, Photograph described as "The Life of Christ." Photograph described as "The incidents of Shakespeare." Photograph described as "Twelve Gms of St. Mary." Photograph described as "Queen Elizabeth and her Nobles."
- MR. EDWARD RERVES** 119, High Street, Lewes, Sussex, Photograph of J. J. Lister Esq., Stratford. Four Photographs of John H. Egkin, Esq.
- MESSRS. MINSHULL AND HUGHES,** Eastgate Row, Chester, Photograph, View of Roman Hypocaust, discovered in Bridge Street, Chester, June 1863.
- MR. WILLIAM S. SUTHERLAND,** 40, Broad Street, Aldersden, A Photograph.

THE PHOTOGRAPHIC NEWS.

Vol. VII. No. 251. July 17, 1863.

CONTENTS.

	PAGE
Lime Toning Baths	337
Photographs in the Last Century	337
Photography in Paris.—Willeme's Photo-Sculpture.....	338
Photographic Chemicals	338
On the Iron Developer. By C. Ommegeanek	339
Photographic Collodion: the Salts it should Contain, and their Proportions. By Charles Heisch, F.C.S.....	340
A Short Lesson in Photography.—No. 13.	341

	PAGE
About Dry Plates	343
The Aesthetics of Portraiture. By R. Disderi	343
Doings of the Sunbeam.....	345
Correspondence—Photographic Reproduction of Pictures.....	346
Photographic Notes and Queries	346
Talk in the Studio	348
To Correspondents	348
Photographs Registered during the past Week	348

LIME TONING BATHS.

PHOTOGRAPHERS are generally craving for some improvement in the process of toning. They have two requirements: one, a process which shall tone with ease and certainty, and be characterized by simplicity; another, that it shall give them black tones if necessary, and add the utmost vigour and brilliancy to their prints. The first demand is easily understood; simplicity and certainty are so valuable, that every practical man desires them. The second demand, the black tones, arises rather from the tastes of the public, who frequently object to warm tones, especially browns. They prefer the black of an engraving, which has become the conventional type of monochrome in demand. The sepia and bistre drawings, and the warm-toned aquatints which were at one time popular, have largely passed out of fashion, and black tones are most commonly admired.

The various lime baths have the reputation of most readily yielding black tones; but a great difficulty is frequently experienced in getting good results without undue bleaching, and, in many cases, mealiness. We have often published formulæ for lime baths, which have, in the hands of some of our correspondents, and in our own, given admirable results, but which have, nevertheless, as we have subsequently learned, when used carelessly, or without due attention to instructions, given bleached, mealy, poor prints. The only remedy we can point out in such cases is a recognition of the fact that free chlorine is the cause of bleaching and mealiness, and where these faults are present there are two remedies: either to reduce the quantity of free chlorine, or to allow the bath to become older before use.

We have recently had an opportunity of inspecting the prints produced by a lime bath, of which we subjoin the formula, which appeared to give the most uniform results of any we have witnessed. On our way to Paris we called at the establishment of Mr. Parkinson, of Dieppe, an English artist settled in France. We there examined many hundreds of prints in different stages of completeness; and apart from the extreme excellence of the photography, we may state that we have never before noticed such perfect uniformity of tone as these prints presented. The tones were throughout of a rich warm black, giving, by virtue of the intensity of colour, the greatest possible brilliancy to delicate prints. This black prevailed throughout, never verging into blue, never suggesting red or brown. A rich, deep, warm black in the deep shadows, with a warm, fleshy effect in the lights and half-tones.

The method of toning we learned was one arrived at by gradual modifications of Ommegeanek's formula, the object having been to secure its advantages with greater simplicity. The method was as follows:—A saturated solution of chloride of lime, with also as much carbonate of lime as it will dissolve, is kept ready mixed. Of this solution, five grammes, equivalent to a little more than a drachm and a quarter, are

added to a litre (35 ounces) of water, to which is added two grains of chloride of gold. The toning solution thus made is very weak; it may be used within a few hours of mixing: but is better used next day, and will keep a few weeks. The paper is excited on a strong silver bath, and a little over-printed, but not very much. A large number of prints are immersed in the toning bath at once, and left with only occasional attention, as there is scarcely any danger to be apprehended to render watching necessary. Nearly an hour sometimes elapses before the print has obtained the deepest black which can be obtained, and even if left longer it does not readily pass into the slaty blue tint of over-toning.

It will be seen that a solution of chloride of lime, if long kept and not closely stopped, would gradually change its character; carbonic acid being absorbed, and carbonate of lime being precipitated. But this need not happen to an appreciable or hurtful extent if due care be used.

Mr. Parkinson's vignettes were especially charming, and derived immense value from this tone. He worked with great rapidity, he informed us, using a Dallmeyer's No. 2 B lens, which gave him infinite facilities in obtaining simple, easy, natural expressions, which long exposures render impossible.

PHOTOGRAPHS IN THE LAST CENTURY.

A SINGULAR and striking corroboration of the probable authenticity of the photographs alleged to have been produced by James Watt, in the latter half of the last century, nearly half a century before the discoveries of Talbot and Daguerre, has just been discovered in the shape of contemporary photographs. All persons acquainted with the history of photography are familiar with the fact, that Wedgewood experimented largely in the production of sun-pictures, and the impression generally obtains that he was successful up to a certain point. It is well understood that he succeeded in producing pictures by the agency of light. He was, we believe, the first who experimented with the solar microscope for this purpose. Up to the present moment, however, it is understood that he did not succeed in fixing, or giving permanency to any of the pictures he obtained. From trustworthy information we have just received, it appears that two of the sun-pictures of Wedgewood, in a perfect state of preservation, have just been discovered.

A lady, well-known in literary circles, who is engaged in the preparation of a biography of Wedgewood, and who has had access to long-buried documents belonging to the deceased *savant*, has found, stored with these papers, two examples of the sun-pictures he produced, together with details of their mode of production. The full historical particulars, together with the technical details, will be published in the "Life of Wedgewood," now in the course of preparation, which will, doubtless, be looked for with interest. We hope shortly to place further information on the subject before our readers.

PHOTOGRAPHY IN PARIS.

WILLEME'S PHOTO-SCULPTURE.

AMONGST the many important applications of photography we know of none more ingenious and interesting than the invention of M. Willeme, to which he has given the name of photo-sculpture. The title is probably familiar to our readers from occasional extracts we have given from French journals and the allusions of our Paris correspondent. The subject had interested us, but we had not so fully realized the *modus operandi* from published accounts as we wished. The method, as described, seemed very complicated, and possibly it may continue to do so to our readers after we have given our description. Nevertheless, in practice it appears beautifully simple and efficient.

M. Willeme is a sculptor of considerable ability; and having derived great aid from photographs as guides in the production of portrait statuary he was led to the ingenious and extended application of our art, the manipular details of which we had recently an opportunity of witnessing. Accompanied by our good friend, M. Ernest Lacan, whose introduction was the *open sesame* to every part of the studio, we first visited the gallery of specimens, consisting of busts and statuette, in various sizes, and some photographs presenting the odd effect of betwixt twenty and thirty full-length portraits, all different views of the same person mounted in succession on one card. Here we learned how the rapidity and ease of the process cheapened production, a full-length statuette, about twenty inches high, costing, we were informed, three hundred francs, or little more than twelve pounds sterling, not more than one-fifth of the cost we should imagine of a similar work produced entirely by hand labour.

We now entered the glass room, which is circular, about thirty feet, or a little more, in diameter, and surmounted by a glass dome. In the centre is a stand upon which the sitter is placed. This stand is polygonal, having twenty-four faces, each duly numbered. Placed at twenty-four regular intervals round the room are twenty-four cameras, the apertures of the lenses alone being seen, each aperture corresponding with one face of the stand upon which the sitter is placed. The sitter being duly posed in suitable position by the sculptor himself, twenty-four wet collodion plates are, by a clever contrivance, exposed simultaneously, securing twenty-four negatives, each with a different view of the sitter, and the number of each negative registered upon it, as given by the face of the polygonal stand. The negatives, securing all these views of the sitter at the same moment, are now ready for the guidance of the sculptor. We shall next see the use to which they are put.

Proceeding to the modelling-room we find M. Willeme himself, engaged upon a life-sized *bas-relief* of the *Duc de Morny*, and two assistants upon a full-length statuette about twenty-four inches high of the same nobleman. The operation is as follows:—A small block, having twenty-four faces duly numbered, being in all respects a counterpart, on a smaller scale, of the central stand in the glass room, is provided to receive the modelling clay, roughly formed into a cylinder of the proper dimensions. Immediately adjoining it is a large ground glass screen, upon which an enlarged image of each negative in succession is projected. We will suppose negative No. 1 is so projected; the side of the block, containing the modelling clay, also marked No. 1, is brought into proper position. A pantograph, suspended in a convenient position for use, is now brought into operation. With one arm the outlines of the negative are traced by one workman on the ground glass, whilst the other arm, furnished with a cutting point or needle, follows the outlines of the negative, making an incision in the modelling clay. This operation completed, another negative is substituted, and the corresponding face of the block brought into position. It does not follow that the next negative will be No. 2; on the con-

trary, it will probably be No. 7, the object being to get such an outline as will, when traced with the cutting point, exactly intersect the cut already made, and thus separate a wedge of the clay from the block. The operation thus progresses, a good deal of judgment and manipular skill being called into exercise at its various stages. When the operation is complete, a complete, roughly cut statuette has been produced by accurately following the photograph by means of the pantograph. It now only remains to be finished slightly by the sculptor, the trifling amount of his services which are necessary being best evidenced by the extremely moderate price at which a complete statuette can be produced.

The result of the finished work is singularly realistic. The absence of certain conventional characteristics, which so often belong to sculptured figures, especially to statuettes, is especially striking. The naturalness and lifelike effect of the photograph are here conferred upon the plastic clay, and the effect is unusually striking and satisfactory. The industry, ingenuity, and ability with which M. Willeme has brought his conceptions into working operation, and the perfection with which this beautiful application of our art is made to aid the sister art of sculpture, is worthy of the highest admiration and praise.

PHOTOGRAPHIC CHEMICALS:

THEIR MANUFACTURE, ADULTERATION, AND ANALYSIS.

PERMANGANIC acid is very remarkable in one of its properties: it is a volatile body, and can easily be distilled. If this acid were prepared in quantity, and could be generally procured in commerce, it would be a better disinfectant and deodorizing agent than even the potash salt so generally used under the name of Condry's fluid. When permanganate of potash is used to destroy organic matter, there is always a certain quantity of potash left behind in the water, increasing with the amount of organic matter oxidized. If permanganic acid be employed for a similar purpose, all the organic matter will be effectually destroyed, and there will be absolutely nothing given to the liquid but what can be removed by filtration. The carbon of the organic matter will be burnt into carbonic acid, the hydrogen will become water, whilst the permanganic acid will be reduced to the state of peroxide of manganese, an insoluble powder capable of removal by filtration.

Permanganic acid is not difficult to make. By adding a teaspoonful of oil of vitriol to a wineglassful of strong solution of permanganate of potash in a dish, Mr. Condry states that there will immediately ascend from the vessel containing the mixture beautiful crimson vapours, which are permanganic acid set free by the action of the acid on the salt. Mr. Terrel has lately investigated the subject very fully. He finds that permanganic acid may be readily prepared by dissolving permanganate of potash in sulphuric acid which has been diluted with half an equivalent of water; adding the salt gradually, and taking care that the temperature does not get too high. The solution is of a yellowish green. This is then introduced into a tubulated retort connected with a well cooled receiver. The only special precaution required to be taken is that no corks or other organic matter must be used in the apparatus. The retort is placed in a water bath, and heated to a temperature not exceeding 60° or 70° C; if a higher temperature be reached, there is danger of sulphuric acid passing over. The apparatus now becomes filled with violet vapours resembling those of iodine. These soon condense in the neck of the retort to a thick liquid of a greenish-black colour, which consists of pure permanganic acid, containing neither sulphuric acid nor chlorine. There is a difficulty in preparing a large quantity of this acid at one operation. When the quantity of acid collected in the receiver begins to accumulate it decomposes spontaneously with a slight detonation, oxygen being evolved, and sesquioxide of manganese left behind.

This difficulty would be obviated by preparing the acid in small portions at a time, and repeating the operation. Many chemical preparations have to be made in a similar way.

If a few drops of water are added to the sulphuric acid solution of permanganate of potash, permanganic acid will be seen to float upon the surface of the liquid in the form of oily drops of a greenish black metallic lustre, which sometimes solidify and fall to the bottom of the liquid. It is difficult to separate this permanganic acid from the sulphuric acid which contaminates, but in this state it will serve very well for most purposes of oxidation. When pure, permanganic acid is a thick liquid, of a greenish black colour and metallic appearance. It seems to be capable of solidifying. It is very greedy of water. Its solution is violet, and it keeps pretty well when dilute and free from dust. If suddenly heated, it detonates, but if gently heated, part volatilizes, producing violet vapours, which possess a very disagreeable metallic odour. This acid is probably the most energetic oxidizing agent known. It instantly sets fire to paper and alcohol, the latter with explosion. In these combustions there are always produced violet vapours, due to the volatilization of a certain quantity of the permanganic acid from the intense heat evolved. When placed in contact with a fatty body, it detonates suddenly, with emission of a beautiful white light. In this case very little acid must be used, as owing to the violence of the action the explosion might give rise to accidents. A very beautiful experiment may be tried with permanganic acid by reacting on it with sulphite of potash. If a few drops of an aqueous solution of the latter salt are added to some of the permanganic acid formed in the sulphuric acid solution of permanganate of potash, a very lively reaction will take place with disengagement of light. A large quantity of acid is carried off in the form of violet vapours, which, meeting with dust and organic matter in the air, are reduced and fall down in the form of brown flocks, very light, similar to oxide of zinc when this metal is burned in contact with the air.

For all purposes in which water free from organic matter is required—and when is such purity not required in photography?—it is essential that some such agent as permanganic acid be employed. Photographers are too apt to rely upon the ordinary distilled water as being perfectly pure—in fact this term is frequently regarded as synonymous with *pure*, which is a great mistake, as ordinarily distilled water most frequently contains organic matter, and sometimes in sufficient quantity to produce very deleterious effects, when employed in delicate photographic processes. Were distilled water generally prepared on purpose—were the final object of the operation in which it is produced, the production of a water which should answer all photographic purposes, there is no doubt that such a result could easily be accomplished. But the case is far different. In most instances, distilled water is merely condensed steam from an engine or boiler, and is allowed to run into vessels set to receive it with no precautions whatever for preventing its contamination with organic matter. The consequence is, that common distilled water, although it may be free from chlorides or sulphates, has an amount of organic impurity in it sufficient, in most instances, to be detected by the smell and taste. This, generally, arises from the grease and oil which so plentifully abounds in the vicinity of steam machinery; but, whatever its origin, it is imperative that it should be got rid of. This is very easily effected by re-distillation from a glass retort, a little permanganate of potash being added to the water, but as it may happen that many photographers may not possess conveniences for distillation, the same perfect purification may be effected by adding a little aqueous solution of permanganic acid to the water, and then boiling violently in a glass flask until the pink colour of the liquid is removed. A brown powder of hydrated peroxide of manganese will be precipitated, and the supernatant liquid, after being decanted, will be as near

chemically pure water as is likely ever to be required, even in photographic manipulations.

Permanganate of potash is the chief source of this acid and its compounds. It is not difficult to make. It is prepared by the spontaneous decomposition of the corresponding manganate dissolved in water. Manganate of potash, owing to the changes of colour which it undergoes during decomposition when dissolved in water, is called *mineral chameleon*. It is formed when any oxide of manganese is ignited with caustic potash, or its carbonate, nitrate, or chlorate. To prepare it, take one part of very finely powdered peroxide of manganese, and ignite it with 3 parts of nitre, till a small portion of the mass taken as a sample and allowed to cool dissolves almost wholly in water, forming a dark green solution. The mixture will become semi-fluid during ignition, and finally assumes a pasty consistence. The crude product so obtained is what is generally known as *mineral chameleon*. It is a blackish green substance which yields a dark green powder, and besides manganate of potash may contain peroxide of manganese, potash, carbonate and nitrite of potash.

ON THE IRON DEVELOPER.

BY C. OMMEGANCK.

The composition of the iron-developing solution employed in photography is based upon the property possessed by the protoxide of iron of reducing the nitrate of silver to the metallic state.

All the salts of iron are not equally well adapted to this purpose. Of the various salts of iron with which we have experimented, the sulphate of the protoxide has given the best results. The acetate and the nitrate of the same base develop only a very feeble image, especially when the bath is recently prepared; when the solutions have become old, and a portion of the oxide is peroxidized by contact with the atmosphere, they develop more energetically, but they rarely give the same intensity as the sulphate: the image they yield is black, instead of a metallic yellowish grey, as obtained from the sulphate. We are of opinion that we must attribute the more powerful reducing action of the sulphate to the sulphuric acid, which forms one of the elements of this latter salt, having more affinity than acetic acid for peroxide of iron; consequently the peroxidation of the iron, at the expense of the salt of silver, is more active in the presence of the sulphuric acid. For a solution of acetate of iron, or of the protoxide of the nitrate, upon contact with the oxygen of the air, deposits the greater part of the peroxide, which is formed in the state of subsalt, while, with sulphuric acid, there is little or no deposit in the solution.

After various experiments, we believe that we can also point out another cause which produces a more complete image with sulphate of iron than with other iron salts, or other developers. At the moment when the iron solution comes into contact with the film of collodion imbued with nitrate of silver, a precipitate of sulphate of silver is produced in the substance of this film, the picture appears in the parts most influenced by light; these parts fix to themselves alone the greater portion of the metallic silver arising from the decomposition of the nitrate, if the latter remains in solution; but as it has been in part precipitated, and as its solution takes place only successively, the parts feebly influenced by light have time to develop their action more slowly upon the sulphate of silver they contain, and in proportion as they are dissolved in the iron solution, which gradually penetrates them. These ideas are not based upon a simple theory, they are fully established by the following experiments.

Sulphate of silver is almost insoluble in cold water: it readily dissolves in a solution of sulphate of potassa or soda, sulphate of iron, and especially sulphate of ammonia. When we pour on the bottom of a test-tube a concentrated solution of nitrate of silver, and we introduce, by gently floating on

to, and mixing with it as little as possible, a layer of one of the above-named sulphates, an abundant precipitate of sulphate of silver is produced; if, after this, we mix the two by stirring with a glass rod, we perceive that the sulphate formed is re-dissolved. When the sulphate employed is the ferric sulphate, the experiment is modified in the following manner: before mixture, only a slight metallic reduction is produced between the layers of different liquids; in proportion as we effect the mixture by a slow agitation, the sulphate of silver is reduced and dissolved, but it does not undergo decomposition so long as it floats in the solid state. If we make use of sulphate of iron and ammonia, we perceive that the metallic grain of the reduced silver is much finer than that produced by the action of sulphate of iron alone.

The proportion of ferrous sulphate varies greatly, according to the various formula for the developing solution. Generally, for negatives, the extreme limits are from 1 to 10 per cent., with equally variable proportions of acetic acid. In our own practice we employ $\frac{3}{4}$ per cent., increasing gradually to 5 in winter, with $1\frac{1}{2}$ per cent., of crystallizable acetic acid.

Recently it has been proposed to employ the double salt of sulphate of iron and ammonia in preference to the simple sulphate, and, finally, it has been found that there is no great advantage in this substitution. Generally, the true value of this modification is not well appreciated. It is said that the double sulphate does not undergo peroxidation in contact with the atmosphere, like the single sulphate. True, in the crystallized state, the double sulphate is a very stable salt, with a clearly defined composition, but when dissolved, it absorbs oxygen just the same as the other salt; in this respect, therefore, there is no advantage; besides, there is a simple sulphate of iron, well crystallized and very dry, which is as pure as the double salt; it is obtained by washing the crystals with alcohol at the moment when they are withdrawn from the mother waters.

Few of the journals which have mentioned the employment of the double salt have shown photographers the equivalent quantities of the two salts; for in preparing an iron solution of four per cent. of double salt, there would be only about three per cent. of ordinary sulphate. The formula of the ordinary sulphate gives us the following proportions:—

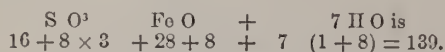

The formula of the double sulphate is:—

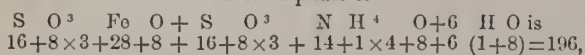

so that 196 parts of double salt contain 139 parts of ferric sulphate. Dividing 196 by 139, we obtain 1 and $\frac{4}{10}$ ths per cent. of double salt, which should be substituted for the simple salt; for a bath of 3 per cent. it should be $4\frac{2}{5}$ per cent., and for a bath of 5 per cent. it should be 7 per cent. of double salt. The double salt is prepared by dissolving in water, with the aid of heat, 139 parts by weight, or an equivalent of crystallized sulphate of iron, and 66 parts by weight, or an equivalent of sulphate of ammonia. Filter the solution, and leave it to crystallize.

According to the experiments published by some photographers, the action of the double salt will be less energetic, less subject to produce fogging. Our own experiments have taught us that the difference of action of the two salts, during the first period of development, is scarcely perceptible, but the employment of the double salt permits of keeping the iron solution upon the plate much longer, and even of renewing it without having to fear fogging with large crystallized particles, which are produced by leaving the iron solution to remain an unreasonable time on the plate while developing. It gives a certain advantage in producing more detail in the shades.

There exists also another degree of hydration of the ferric sulphate, which is the monohydrated sulphate.

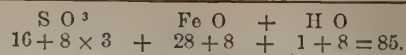

It is very necessary to prepare an iron solution strictly proportioned: it is obtained by throwing some alcohol into a saturated solution of sulphate of iron; a white powder is precipitated which is the sulphate with an equivalent of water: it keeps well, its composition is always constant. 85 parts of this salt correspond to 139 of ordinary sulphate, or, in round numbers, 6 parts of monohydrated salt to 10 of ordinary sulphate. It can be easily weighed, because it is in very small crystals, and for the same reason it dissolves in water immediately, in the preparation of the developing solution.—*Bulletin Belge de la Photographie.*

PHOTOGRAPHIC COLLODION: THE SALTS IT SHOULD CONTAIN, AND THEIR PROPORTIONS.

BY CHARLES HEISCH, F.C.S.*

A good collodion should contain from five to eight grains of pyroxyline to the ounce. A pyroxyline, of which six grains cannot be dissolved in one ounce of mixed alcohol and ether without making it too thick to flow readily, will not make a really good collodion. The best proportions of ether and alcohol are, as a rule, equal quantities of each. Four drachms of ether and two of alcohol should be mixed, and the six grains of pyroxyline added, to make the plain collodion; the requisite quantity of iodide, &c., should be dissolved in the remaining two drachms of alcohol, and the collodion, after getting clear, added to them, to make the ounce of prepared collodion.

The nature and proportion of the iodides and bromides employed, should be regulated by the use to be made of the collodion. Where only black and white subjects, such as engravings, are to be copied, a simple iodide, or an iodide with a small quantity of chloride to increase the intensity of the blacks, is all that is necessary. Bromide of silver, being more readily affected by light of various colours than iodide, and giving also much greater delicacy of half-tone, a bromide should always be employed in conjunction with an iodide, either for landscape or portrait collodion where the best possible results are desired. The qualities which it is most desirable to unite in order to form a perfect collodion, are the maximum of sensibility to light, not only white but coloured, and the power of bearing an exposure sufficiently long to bring out the detail in the deepest shadows, without becoming solarised in the lighter parts.

Much discussion has recently taken place, as to whether the presence of bromides increases the sensibility of collodion, and many contradictory assertions have been made on the subject. I believe these contradictions are mainly owing to the fact, that but few of the experimenters have paid any attention to the proportion of the bromide to the iodide, or of both to the quantity of pyroxyline in the collodion. To attain the maximum of sensibility, the collodion should contain, after being sensitized, as much silver (whether as iodide or bromide), as can be retained firmly by the film. If it contain less than this, the silver salts are so surrounded by pyroxyline, as to be comparatively insensible; if it contain more, the silver salts wash out into the bath, and leave streaks on the film. It is universally admitted that in the daguerreotype process, bromide, in conjunction with iodide of silver, is far more sensitive than iodide alone. The reason of this universal admission I believe to be due to the fact, that a very slight difference in the proportions of iodide and bromide in this process renders a plate not only less sensitive, but almost insensitive, so that daguerreotypists were obliged to pay that strict attention to proportions, which the experimenters in collodion have many of them failed to do, and hence, I believe, has arisen the discrepancies in their opinions.

A careful consideration of the very slight difference of

* From "The Elements of Photography."

proportions which so completely altered the state of a daguerreotype plate, convinced me that it could only be satisfactorily accounted for on the supposition that there is a real chemical compound of iodide and bromide of silver, which possesses in an eminent degree the two qualities of sensibility, and resistance to solarisation. Many experiments led me to the same conclusion. In 1851, I made a long series of experiments to see if iodides and bromides mixed in the proportion of their chemical equivalents, would not give those two properties both to paper and collodion in a greater degree than if they were mixed at random; and I arrived at the conclusion that in all cases a mixture of two equivalents of iodide to one equivalent of bromide, was far more sensitive than iodide alone, or any haphazard mixtures of the two. These experiments were repeated some years after, and the results exhibited at a meeting of the Blackheath Photographic Society. In all the collodion experiments, the quantities of iodides and bromides employed were so arranged, that six grains of pyroxyline were mixed with either iodide or bromo-iodide of silver, equivalent to 4.2 grains of silver, so that the experiments were strictly comparable. No subsequent experience has in the least modified my conclusions on this subject.

The nature of the base with which the iodine and bromine in collodion are combined, exerts a remarkable influence on the character of the sensitive film. Comparatively few bases can be employed, more especially where both iodides and bromides are required, as many iodides, and more bromides, are insoluble in alcohol and ether. The salts most available are those of ammonium, cadmium, lithium, magnesium, potassium, or zinc. Of these, potassium (the first employed), has now gone almost out of use, as the iodide is but sparingly soluble in any but weak alcohol, and the bromide almost insoluble. The salts of cadmium possess the advantage of being very stable, so that collodion prepared with them may be kept ready iodized for an almost indefinite time without change, a great advantage to those who only work occasionally. The greatest sensibility appears to be obtained by the use of those salts whose chemical equivalents are the lowest, which in fact leave the silver salts in the state of greatest purity in the film. Thus the salts of lithium, magnesium, and ammonium, give the most sensitive collodions, 6.43 parts of lithium, 12.67 of magnesium, and 18 of ammonium, being respectively equivalent to 55.74 of cadmium, and 39 of potassium. A great advantage also possessed by the salts of lithium and magnesium, is that the compounds formed by them on immersion in the bath of nitrate of silver are deliquescent, so that they tend to keep the film moist. On a hot day a plate prepared with a cadmium collodion, will in a given time be so dry as to render it almost impossible to pour the developing solution over it, while one prepared with magnesium or lithium collodion will be quite moist, and allow the developer to flow over it without difficulty. The following are the formulæ for collodion and iodizers which I found most useful:—

COLLODION.			
Pyroxyline	48 grains.
Ether	4 ounces.
Alcohol	2 "
IODIZING SOLUTIONS.			
No. 1.			
Iodide of Ammonium	30 grains.
Bromide of Ammonium	10 "
Alcohol	2 ounces.
No. 2.			
Iodide of Cadmium	38 grains.
Bromide of Cadmium	14 "
Alcohol	2 ounces.
No. 3.			
Iodide of Magnesium	29 grains.
Bromide of Magnesium	2.5 "
Alcohol	2 ounces.

No. 4.			
Iodide of Lithium	27.5 grains.
Bromide of Lithium	9 "
Alcohol	2 ounces.
No. 5.			
Iodide of Ammonium	40 grains.
Chloride of Calcium	3 "
Alcohol	2 ounces.

The ether and alcohol employed for this purpose should be pure and anhydrous. In mixing the collodion and iodizer the former should always be poured into the latter, as alcohol is the real solvent of the iodides, and if their solution be poured into a large quantity of collodion, some of the salt is often precipitated by the excess of ether present.

It is better never to use collodion till it has been iodized at least 24 hours. When the cadmium iodizer is employed, it should be kept much longer, it goes on improving for many weeks. The iodizer, No. 5, I employ principally where only black and white objects have to be copied, and when it is desirable to obtain great depth in the blacks, and purity in the whites, as in copying engravings, &c.

Should a thinner collodion be required, the quantity of iodides and bromides employed must be decreased in the same proportion as the pyroxyline, or the whole may be thinned after iodizing, by the addition of a mixture of equal parts of ether and alcohol. Should the collodion become too thick by use, it may be restored to its original consistence by the addition of the same mixture. In very hot weather it is sometimes well to increase the proportion of alcohol, and diminish that of ether, but as a rule, the above proportions answer the best.

A SHORT LESSON IN PHOTOGRAPHY.—No. 14.*

My instructions hitherto have been limited strictly to the chemical and mechanical manipulations that occur in that department of photography denominated the *wet collodion process*. This process will ever remain the predominant mode of conducting photographic operations in the room; it is preferred too by many tourists in the field. The inconvenience, however, of dragging along, over mountain and valley, or of stowing away on steamer or on the cars, a complete miniature operating gallery, has suggested the idea of superseding all this trouble by the discovery of a *dry collodion process*. Several processes have been discovered, which are more or less successful, and very practical; but it must be confessed that the same degree of sensitiveness in the dry process has not yet been attained as in the wet process—instantaneous pictures are the result only of the latter. It appears natural for us to expect such a result; chemical combinations and reductions are effected most easily when the molecules of matter are in such a condition as to have freedom of locomotion by which new molecular arrangements can be formed in accordance with the new electro-chemical attractions and repulsions superinduced by the contact of dissimilar bodies.

For landscape, and especially for architectural photography, for copying, as well as for every case of still life, where the time of exposure is not important, dry plates are decidedly superior to wet ones, because of the uniformity of their condition during the time of exposure; wet plates, on the contrary, by desiccation are continually changing; and one of these changes, the concentration of the nitrate of silver during evaporation, is one of the causes that produce minute apertures in the film. The aim of a dry plate is to attain to a maximum of preservation of the sensitiveness for an indefinite time.

It has happened hitherto that the ratio of this preservation is inversely as the time of exposure, or probably in plainer terms, that the better the plate is preserved so as to retain sensitiveness, the longer the time required to be exposed to the actinic influence to produce a given effect. The theory, that is, the rational elucidation of the action of reduction in a dry plate, is still a problem; if the wet plate, after sensitization, be thoroughly washed, and then exposed, no picture is developed by the re-

* From Humphrey's Journal.

ducing agent;* but in the dry plate, the film is very carefully washed and then coated with some preservative agent, as it is called, such as albumen, tannic acid, gelatine, honey, syrup, infusion of malt, glucose, &c., and then, when otherwise properly prepared and dry, it will yield, when exposed and afterwards subjected to the action of a reducing agent, an intense picture. I say the rationale of this phenomenon is still a problem.

Some suppose that the albumenous, colloidio-albumenous, gelatinous, &c., film becomes permeable to the developer in the dry process, whilst the collodion film in its simple unpreserved condition is not so. Such a supposition is, however, the mere admission of our inability to render any satisfactory explanation.

As yet also it is a difficult task to say which of the dry processes in vogue is actually *the best*; although, perhaps, the majority would throw the weight of their opinion into the scale of the fannin process. The dry processes most conspicuously on the carpet are: the albumen process; the colloidio-albumen or Taupenot process; the gelatine, or Dr. Hill Norris's process; the tannin process of Major Russell; and the resin process.

The Albumen Process.

This process was in use several years before that of collodion; Niepce de Saint Victor first produced negatives with it. It is still employed by some of the most distinguished artists in the production of stereographs and photographs of interiors and pictures of still life. Its theory is very simple, but its manipulation demands great care and skill.

Formula for Iodized Albumen.

The white of egg	10 ounces
Iodide of ammonium	44 grains
Distilled water.			

Dissolve the iodide in the water, then add the solution by degrees to the white of egg entirely freed from the germ and yolk, and beat up the egg well with a wooden spatula until it is completely converted into froth. This operation must be performed in a place as perfectly free from dust as possible; and then the albumenous mixture is covered with a clean sheet of paper and put aside to settle for a number of hours. After standing the required time, the surface becomes covered with a sort of incrustation, through which an aperture is made to allow the iodized albumen to flow out. In some formulas for iodizing the albumen a bromide is used, and a small quantity of free iodine as follows.

Formula No. 2.

The white of egg	10 ounces.
Iodide of potassium	44 grains.
Bromide of potassium	15 "
Free iodine	2 "
Distilled water sufficient to dissolve the salts.			

Beat up with the white of egg as before. The operation is best performed when the temperature of the room is low. A few hours previous to the operation of coating the plates, mop the floor and wipe all the shelves with a damp cloth—the great trouble in the process is the deposition of dust or fibres on the glasses during the time they are drying. Another trouble—and these are about all the difficulties the operator has to contend with—is the flowing of the plate with an even and uniform film and its uniform retention on the plate until dry. The plates, of course, must be *perfectly clean* in this process, as in every other for negative purposes.

Several methods have been proposed by which the plate can be covered with a uniform film of albumen. Fortier recommends the use of a dropping tube capable of holding twice as much albumen as is required to cover the plate; this is filled about three-fourths full with the albumen by suction with the mouth, and then the upper aperture is closed with the first finger of the right hand. The plate, well cleaned, well dusted, and marked on the back with a diamond or with a small wafer, is inclined at an angle of not more than ten degrees with the horizon; breathe upon the plate, and then with the tube on the upper right hand corner allow the albumen to flow out; in the meanwhile carry the tube to the left side; then go back to

the right side, and proceed thus until three-fourths of the plate is covered: the quantity of albumen is supposed now to be sufficient, by a little management with a triangle of glass, to cover the whole plate.

Such a method as this, and many others quite similar to it, are sufficient to deter photographers from taking albumen pictures.

Another method, recommended by Couppier, consists in fixing on the back of the glass a long stem or handle of the thickness of a black lead pencil, with a cup-shaped cavity at the top, the sides are about a quarter of an inch in thickness, the whole having something of the appearance of an inverted hand bell. On the rim of the cup gutta-percha is melted. This gum can always be softened by heat when required for use, and when softened it is applied to the centre of the back of the plate by pressure. In this way the plate when cold adheres firmly to its handle. Noton's pneumatic holder, of course, is a superior substitute.

The plate is now flowed with albumen as you would with collodion; the greatest part of the surplus is taken off at the right-hand nearest corner; the albumen then is allowed to flow back to the left-hand farthest corner, and finally back to the middle. By a rotary motion communicated to the stem of the holder between the two hands, the collodion, affected by the centrifugal force, becomes uniformly distributed over the surface; and then, by a slight pressure of the thumb beneath the plate, the latter is removed from its connection with the stem, and put away to dry on a horizontal plane in a drying box or cupboard, to which dust can have the least access possible. If the plane be not horizontal, or if the glass be not uniform in thickness, the film of albumen will settle to the lowest points, and thus when dried will produce unequal action in the printing process. By this method the drying will not be effected in less than a day, during which time particles of dust may get admission and entirely spoil the plate.

The following is another method, modified from that of M. Ferrier:—

Supposing that stereoscopic negatives are required to be manipulated with:—Take a piece of brass about one-sixteenth of an inch in thickness, one quarter of an inch wider and longer than stereoscopic plates. Cut out all the interior portion, leaving only an outside skeleton half an inch wide. Turn up one-eighth of an inch so as to form a ledge, which will prevent the plate from falling out when once placed in this dish. Drill a hole in each corner of this ledge, or solder a ring at each corner on the outside. Be very particular that this skeleton dish lies horizontal when rested on a horizontal plate or board. To each ring attach a cord twelve inches in length, and bringing these cards together, tie them into a knot in such a careful manner that the brass dish, when suspended by the knot or by a ring in the knot, shall be also quite horizontal. It is evident by such a contrivance that a rotatory motion can easily be communicated to the plate by simply rotating the ring of suspension.

The plate is breathed upon and flowed with albumen; the surplus quantity is removed as before directed, and then the plate is placed upon the brass dish. Suspending the dish, a rotatory motion is communicated to it, and the film is made uniform. Previous to the operation of thus covering the glass, a plate of iron, about a foot square and supported on iron legs, is placed over an alcohol lamp or on one of the rings of a retort stand, and is made warm by the flame of the lamp. The suspended albumenized plate is brought right over the heated iron plate and rotated gently where there is a tendency in the albumen to accumulate unevenly. In a few minutes the plate will be dry and can be stowed away in a box with grooves for its reception. The excess of albumen is poured into a separate vessel, as it is not advisable to use it over again; nor is it advisable to use more than about three-fourths of the albumen after subsidence for a day or two; for the residuo at the bottom contains impurities that would detract from the perfection of the picture. The preparations of iodized albumen have to be used whilst fresh; consequently make it a business to coat as many glasses at a time as the albumen will cover for economy's sake.

Sensitizing the Film.

An oblong flat porcelain or glass dish is preferred to the vertical bath for the purpose of sensitizing the film; and if the dish be made twice as long as required it will answer the purpose best.

* This statement is scarcely correct. A sensitive collodion film containing iodide of silver only, if washed thoroughly and then exposed, will not yield an image without the addition of nitrate of silver to the developer. If this addition be made a picture is produced, but the exposure must be longer than for an un-washed plate. If the washed film contain bromide as well as iodide of silver, a faint image is developed without the addition of free nitrate.—ED. PHOTO NEWS.

Formula for Sensitizing Solution.

Nitrate of silver	1 ounce
Acetic acid	5 ounces
Distilled water	10 "
Iodide of potassium	2 grains.

Lay the albumen plate along one side of the glass dish, then raise this side and pour into the inclined side a sufficient quantity of the bath; with a dexterous move raise the inclined side so that the fluid may flow over the albumen film in one quick continuous layer. By this contrivance all lines or marks of stoppage are avoided. This is a very necessary provision here; for the slightest hesitation or stoppage will infallibly show its effect on the negative. About half a minute will be sufficient to *coagulate the albumen and to sensitize the film.* The operation is performed in the dark room. After sensitization the plate is removed from the bath by raising it first with a bent silver hook, and then seizing it by one corner with the hand. It is then washed under the tap, and left to soak in a dish of distilled water until the next plate is prepared.

The quantity of acetic acid in the above formula may be diminished in many instances; its object is to prevent fogging, but it diminishes sensitiveness at the same time. If with half the quantity no fogging supervenes, this quantity will be quite enough: in this manner, that is, beginning with a small amount of acetic acid, and gradually increasing until fogging ceases, more rapid effects may be obtained in the exposure. When the sensitized plates are kept long, they undergo a species of decomposition which induces fogging; the fresh plates, therefore, are in the best condition for producing normal effects with the greatest rapidity, because the sensitizing bath requires the least amount of acid.

Blisters are apt to arise in the film by immersion in the sensitizing bath, or during the subsequent operations. These are frequently owing to the imperfect cleaning of the plates, or in the clumsy flowing of the albumen. Gummy substances are sometimes added to the albumen in order to render it more adherent or less contractile.

The amount of exposure will depend on the conditions of light, the focal length of the lens, and the sensitiveness of the albumen. In the bright light of spring an exposure of two or three minutes with a pair of stereoscopic lenses will, in general, be amply sufficient. Experience alone can determine the amount of time required in a given case.

Development of the Image.

The plate is placed in a glass dish or in one of gutta percha, and the developer is poured upon it by the same mode of manipulation as just described to be used in the sensitizing operation.

Formula for the Developing Solution.

Gallic acid	8 grains.
Distilled water (90° Fah.)	2 ounces.

Previous to immersion in the above solution the plates are subjected to the softening action of a warm dilute solution of gallic acid (one grain to the oz. of distilled water), for half an hour. After this the plate is flowed with a sufficient quantity of the above solution containing five or six drops of a solution of nitrate of silver two per cent. strong. The image will soon begin to appear, and will proceed until the vigour of the print is satisfactory. The development is not so soon complete as in collodion operations, the time required varying from a few minutes to forty minutes or an hour. Almost any amount of exposure can be made to yield a good picture, by adapting the developing solution in accordance with the exposure. If the plate has been *under-exposed*, more silver will have to be used; if *over-exposed*, less will be found to be all that is necessary. Silver from the sensitizing bath might be used, but in this case it must contain more acetic acid. The weak solution above prescribed is to be preferred; and if there is a tendency to fogging, add a few drops of acetic acid to counteract the effect. As soon as the shades are sufficiently dense, the plate is removed from the bath, well washed in many waters, and then the image is fixed in a solution of hyposulphite of soda. No varnishing is required, because the albumen film is quite hard of itself.

ABOUT DRY PLATES.

BY J. MILTON SANDERS, M.D., LL.D.

ALTHOUGH much has been written upon the subject of dry plates, still it has not been exhausted, for the process has yet

to be discovered. The process I have followed for years I now describe, together with the recent improvements I have made. The collodion for this purpose must be prepared in the following manner:—In eight fluid ounces of alcohol, put eighty grains of gun cotton. Allow the cotton to remain in the fluid long enough to become thoroughly saturated, then you must pour on it eight fluid ounces of ether; shake, and the cotton will dissolve. Now add to it eighty grains of iodide of cadmium, and sixty grains of the bromide of the same metal, shake until the salts are dissolved and your collodion is finished. This collodion should remain standing in a shaded place for about a week, before it is fit for dry plates.

When ready to use, pour out one or two ounces of it in your collodion vial, and add sufficient tincture of iodine to it to change it to a dark brandy red; but the great body of the collodion should not be thus treated, or the iodine will deteriorate in a few days.

To prepare the dry plates proceed as follows:—Sensitize your plate with the above collodion in a fifty-grain bath, leaving it in the bath at least three minutes before you consider it thoroughly sensitized. Now take it out, hold it under the tap until all the nitrate of silver is washed off, and then pour upon it a filtered solution of twenty grains of tannic acid to the ounce of water.* I previously used a thin solution of albumen, but I find that tannic acid is fully as good, if not better.

Having poured off and on the tannic solution several times, drain the plate well, and place it away in your dark box.

Having placed the plate in your camera, give it about twice the length of exposure you would a wet plate. Return to your dark room, take the plate from the holder, and hold it under the tap until the tannic solution is washed off, and the collodion surface is thoroughly wetted. Now pour over it, or flow upon it, a fifty-grain solution of nitrate of silver, saturated with iodide of that metal † (or with some of your bath solution.) Drain it slightly, and develop with the following new developer:—

Water	20 ounces.
Sulphate of iron	1½ do.

Dissolve the iron, and with ammonia produce a slight precipitate in the solution. Then add—

Acetic acid, No. 8	2 ounces.
--------------------	-----	-----	-----	-----------

—Filter. ‡

Under this developer the picture will soon exhibit itself clear and intense; but if it should not come out sufficiently intense, intensify it further with bichloride of mercury, afterwards flowing upon it some diluted aqua ammonia to blacken the bichloride. I would mention that the developer given above will answer an admirable purpose for all wet plates. It brings out the picture beautifully clear and transparent, much more so than if the free sulphuric acid were allowed in the developer. I would further state that although I may be the first person to avail myself of this form of developer, that I was induced to do so through a suggestion of Professor Seely given in the April number of the *American Journal of Photography*.—*American Journal.*

St. Domingo, W. I., May, 1863.

THE ÆSTHETICS OF PORTRAITURE.

BY R. DISDREI.

(Continued from p. 332.)

The group portrait is often very much abused; and off all the different kinds of portraits, it is the one to which the very

* The tannic acid should be filtered in vacuo, if possible, for if exposed but a brief time to the air, a reaction takes place, oxygen is absorbed, carbonic acid given out, and gallic acid is formed. This latter acid will play the devil with your plate!

† We must caution our readers against following this suggestion. The iodide is not only useless, but mischievous.—*Ed. PHOTO. NEWS.*

‡ This solution must be used freshly made, as age soon deteriorates it.

§ A similar developer has been used in England for years, and repeatedly published.—*Ed. PHOTO. NEWS.*

worst attempts belong. If it is already so difficult to make a good likeness of a single person, how much more so must it be, to compose a scene in which, almost always, the individuals are of different age, sex, and character! Each member has his individual type, which must necessitate a particular choice of attitude, light, and expression. The painter is enabled to produce a certain unity by means of colour, modification of the form, and various other resources which his art places within his reach; but the photographer finds himself face to face with the reality, and must, of necessity, meet with obstacles which the most ingenious and complicated combinations of his art are powerless to overcome.

The method to which all the artists who have obtained the best portraits of this nature, have had recourse, consists in grouping and combining the different persons, as it were, by means of some action common to them all. It is thus that a mother is represented playing with her child; girls, admiring a piece of needlework; persons, examining an album of drawings, &c.

The photographer has taken advantage of every subject of this kind, and has almost invariably given some common employment or action to the persons which compose the group. We cannot but remark that some of these conceptions are weak and puerile. Our readers will naturally observe that an action should always be chosen that is calculated to represent the persons to advantage, without appearing improbable. The simpler this action is, the better for preserving to the picture the character of a portrait.

To make a portrait is, in fact, to represent an individual, and not an action; and, moreover, to represent him in a complete manner, he must be seen in his general and natural attitude, and not in the complicated and particular position you have placed him in. This observation is applicable with equal force to the representation of a single figure, as to that of a group. The action must be reserved for pictures, and scenes which are intended to represent a passion or a strong sentiment. But, for us, the subject is a portrait, and nothing more. The type, the bearing, and the character, constitute the interest, and this it is that we have to represent. It is in the works of the great masters that we must study the simple, yet grand, method of composing a portrait: Raphael, Titian, Vandyke, and Velasquez, have excelled in this. They have painted the men, and not merely their actions.

We have thus far spoken only of the dimensions and proportions of the model which are to be preserved and embellished in the portrait, regardless of the attitude chosen. We will now proceed to consider the pose of the figure.

The choice of position is extremely important, with regard to resemblance, and it is particularly in this that the artist must understand his model, and have a clear idea of the character of the person he wishes to represent.

The majority of photographers have two or three different positions to which they submit all their models, whether tall, short, long, or small. Moreover, nearly everybody, before having a photograph, studies and chooses an attitude beforehand, by the aid of a mirror, which, in many cases, is quite contrary to their natural bearing; a lady, for instance, of doubtful age, will take the free attitude of a young girl; a small, quiet-looking man, has an ambition to appear proud and bellicosus. The result of this is, that a great many portraits appear studied and stiff, of which the least fault is a perfect failure in resemblance, and generally in beauty.

The first condition of a good attitude is, that it should be in harmony with the age, stature, habits, and manners of the individual; secondly, that it should express the greatest beauty of which the model is susceptible. As we have already stated, the perfect knowledge of the individual is the sole guide for a suitable choice of the position; the defect to be most guarded against, is that caused by borrowed and studied attitudes. The photographer must, therefore, observe attentively, reflecting on his subject, and try, by all

possible means, to engage the attention of his model, and to endeavour to make him cease to think of the portrait for which he is come, seizing and noting the natural movements which are visible during these short intervals of forgetfulness.

The model, however, when seen in a natural manner, and perfectly free from any assumed bearing, will still present such a number of attitudes, that it would be very embarrassing to choose, if one had not already formed a clear idea as to the style in which the portrait should be represented. The model of which the character and type should be represented, in a serious and severe style, often present to the artist a number of accidental poses, which, although very natural in themselves, do not, however, give a complete idea of the person, and should, consequently, be rejected. It is the characteristic attitude that must be expressed, not one particular moment, but all the moments—the whole individual, in fact.

It is, moreover, necessary for the position to express unity of aspect, and that it be optically correct. One must, therefore, find a dominant movement which is in accord with all the other parts. The accessory movements, which present themselves naturally, fortify the unity of the figure, and render the aspect of it easy to seize. There will be a natural contrast of the principal lines, and one may invariably find means, in the disposition of the members, to bind these contrasts together by a series of accessory lines, which bring to mind, more or less, the principal ones. The dress, &c., is an important aid in attaining that harmony and unity of movement and form, which constitutes the optical beauty of the pose.

We have now to speak of physiognomy. As we have seen, it is not the real base of the resemblance, as is supposed by most photographers. It is, however, a very important condition, by means of the just proportion given to the face, with regard to the rest of the figure, and completes the harmony, beauty, and resemblance of the portrait.

The great difficulty here, as in the choice of attitude, is to distinguish from the multitude of different expressions presented by the model, the one which is most in accordance with the sentiment which is intended to be expressed by the "ensemble" of the portrait, and is at the same time the most favourable to a good resemblance. It is always the same law that should guide the artist; it is absolutely necessary that the just expression be visible through all the passing shades of the physiognomy; the fugitive movements of the head, the lip, the eyes; in short, that it should contain, and express, in itself, all the minor complementary details, and give the true character of the individual.

The artist must be strictly on his guard against borrowed and studied expressions, and act with much circumspection if he does not wish to run the risk of being deceived by the change. He will animate the face of the person by a varied conversation, noting in his mind the varied expressions; and, the moment arrived for taking the image on a sensitive plate, he will endeavour by all the means in his power to revive the one that he has chosen. This choice, therefore, requires a good deal of promptitude of observation and sure tact. This faculty is not given to all operators, nor even to the most able, and those who are endowed with the sentiment of the art. The changes are so rapid on the visage of the model, the shades so delicate and fugitive, as to elude the eye of the most skilful. It is not the wish of the operator that can give such and such an expression to the features, but the sentiment which animates and gives to the visage a corresponding expression to the sentiment awakened in the mind of the model. The artist will, therefore, seek, at the decisive moment, to revive the ideas which ought to give the model the expression that he has observed and chosen. How is he to succeed in this? is a very delicate question. The faculty of imitation is innate in man: sorrow and joy are contagious. If you observe a spectator at the theatre, you will see his physiognomy put itself in unison with that of the actor who interests

him; you will see the varied shades and changes of the scene pass over his countenance. The photographic artist has no other means of reviving the expression in the features of his model, than by taking the expression himself. He must, therefore, identify himself with the moral situation that he desires to create in the person to be represented, which is the only way of giving to his physiognomy the necessary expression for a perfect portrait. How often have we noticed the influence of the operator over the model? When some unexpected unpleasantness gives our face a cross expression, all the traits of our visage are reproduced in that of the model.

To obtain a good result, it is, before all, necessary that the artist be alone with the model. The least interruption with either will always compromise the success of the operation; this rule should be most strictly observed in the case of children. One should always avoid instructing them to smile, or to hold the head in such a manner, to be perfectly quiet, and all other such cautions as parents are in the habit of giving their children,—as when their minds are thus confused and preoccupied, it is almost impossible for the operator to obtain a faithful and pleasing pose. A child should be photographed without its being conscious of it.

The photographic atelier should always be separate from the laboratory, and perfectly removed from all noise, like that of the sculptor or painter.

It would be useless to enumerate all the false and disagreeable expressions of feature observable in so many portraits. We will however, notice a few of the most ordinary. In one, a smile has been attempted, and the model, according to the instructions of the photographer, has contracted the corners of his mouth, and thereby produced a grimace. In another, a tedious or tired expression replaces one of dignity or gravity. Such defects are caused by the artist not understanding his model, and being, therefore, unable to guide and direct him; in fact, he is wanting in either the practice or theory of his art. People are apt to think that the success often depends on the person to be represented, who will not submit to the wish of the operator, and persists in preserving some false or unfavourable expression. We would answer that the true artist would always find means of persuading his model to place himself under the necessary conditions. Moreover, he is never obliged to reproduce an absolutely obstinate model; and he should on no account become responsible for all the deformities that are presented to him.

DOINGS OF THE SUNBEAM.

[UNDER this title one of the most eloquent transatlantic writers, Oliver Wendell Holmes, gives, in the *Atlantic Monthly*, a picture of photography in the United States, commencing with a description of the establishment of Messrs. E. and H. T. Anthony, of New York. With one or two trifling excisions we reproduce the article.]

The guests of the neighbouring hotels, as they dally with their morning's omelet, little imagine what varied uses come out of the shells which furnished them their anticipatory repast of disappointed chickens. If they had visited Mr. Anthony's upper rooms, they would have seen a row of young women before certain broad, shallow pans, filled with the glairy albumen which once enveloped those potential fowls.

The one next us takes a large sheet of photographic paper (a paper made in Europe for this special purpose, very thin, smooth, and compact), and floats it evenly on the surface of the albumen. Presently she lifts it very carefully by the turned-up corners and hangs it *bias*, as a seamstress might say, that is, cornerwise, on a string, to dry. This "albumenized" paper is sold most extensively to photographers, who find it cheaper to buy than to prepare it. It keeps for a long time uninjured, and is "sensitized" when wanted, as we shall see by-and-by.

The amount of photographic paper which is annually imported from France and Germany has been estimated at fifteen thousand reams. Ten thousand native partlets—

"Sic vos non vobis iudicatis, ares"—

cackle over the promise of their inchoate offspring, doomed to perish unfeathered, before fate has decided whether they shall cluck or crow, for the sole use of the minions of the sun and the feeders of the caravanseras.

In another portion of the same establishment are great collections of the chemical substances used in photography. To give an idea of the scale on which these are required, we may state that the estimate of the annual consumption of the precious metals for photographic purposes, in this country, is set down at ten tons for silver, and half a ton for gold. Vast quantities of the hyposulphite of soda, which, we shall see, plays an important part in the process of preparing the negative plate, and finishing the positive print, are also demanded.

In another building, provided with steam-power, which performs much of the labour, is carried on the great work of manufacturing photographic albums, cases for portraits, parts of cameras, and of printing pictures from negatives. Many of these branches of work are very interesting. The luxurious album, embossed, clasped, gilded, resplendent as a tropical butterfly, goes through as many transformations as a "purple emperor." It begins a pasteboard larva, is swathed and pressed and glued into the condition of a chrysalis, and at last alights on the centre-table gorgeous in gold and velvet, the perfect *imago*. The cases for portraits are made in lengths, and cut up, somewhat as, they say, ships are built in Maine, a mile at a time, to be afterwards sawed across, so as to become sloops, schooners, or such other sized craft as may happen to be wanted.

Each single process in the manufacture of elaborate products of skill oftentimes seems, and is, very simple. The workmen in large establishments, where labour is greatly subdivided, become wonderfully adroit in doing a fraction of something. They always remind us of the Chinese or the old Egyptians. A young person who mounts photographs on cards all day long confessed to having never, or almost never, seen a negative developed, though standing at the time within a few feet of the dark closet where the process was going on all day long. One forlorn individual will, perhaps, pass his days in the single work of cleaning the glass plates for negatives. Almost at his elbow is a toning bath, but he would think it a good joke, if you asked him whether a picture had lain long enough in the solution of gold or hyposulphite.

We left the great manufacturing establishment of the Messrs. Anthony more than ever impressed with the vast accession of happiness which has come to mankind through this art, which has spread itself as widely as civilization. The photographer can procure every article needed for his work at moderate cost, and in quantities suited to his wants. His prices have, consequently, come down to such a point that pauperism itself need hardly shrink from the outlay required for a family portrait-gallery. The "tin-types," as the small miniatures are called—stannotypes would be the proper name—are furnished at the rate of *two cents* each! A portrait such as Isabell could not paint for a marshal of France—a likeness such as Malbone could not make of a President's lady—to be had for two coppers—a dozen *chefs d'œuvre* for a quarter of a dollar!

We had been for a long time meditating a devotion of a part of what is left of our more or less youthful energies to acquiring practical knowledge of the photographic art. The auspicious moment came at last, and we entered ourselves as the temporary apprentice of Mr. J. W. Black, of this city, well known as a most skilful photographer, and friendly assistant of beginners in the art.

We consider ourselves at this present time competent to set up a photographic ambulance, or to hang out a sign in any modest country town. We should, no doubt, over-time and under-tone, and otherwise wring the countenances of some of our sitters; but we should get the knack in a week or two, and if Baron Wenzel owned to having spoiled a hat-full of eyes before he had fairly learned how to operate for cataract, we need not think too much of libelling a few village physiognomies before considering ourselves fit to take the minister and his deacons. After years of practice there is always something to learn, but every one is surprised to find how little time is required for the acquisition of skill enough to make a passable negative, and print a tolerable picture. We could not help learning, with the aid that was afforded us by Mr. Black and his assistants, who were all so very courteous and pleasant, that, as a token of gratitude, we offered to take photographs of any of them who would sit to us for that purpose. Every stage of the process, from preparing a plato

to mounting a finished sun-print, we have taught our hands to perform, and can therefore speak with a certain authority to those who wish to learn the way of working with the sun-beam.

Notwithstanding the fact that the process of making a photographic picture is detailed in a great many books, nay, although we have given a brief account of the principal stages of it in one of our former articles, we are going to take the reader into the sanctuary of the art with us, and ask him to assist, in the French sense of the word, while we make a photograph—say, rather, while the mysterious forces which we place in condition to act work that miracle for us.

We are in a room lighted through a roof of ground glass, its walls covered with blue paper to avoid reflection. A camera mounted on an adjustable stand is before us. We will fasten this picture, which we are going to copy, against the wall. Now we place the camera opposite to it, and bring it into focus so as to give a clear image on the square of ground glass in the interior of the instrument. If the image is too large, we push the camera back; if too small, push it up towards the picture and focus again. The image is wrong side up, as we see; but if we take the trouble to reverse the picture we are copying, it will appear in its proper position in the camera. Having got an image of the right size, and perfectly sharp, we will prepare a sensitive plate, which shall be placed exactly where the ground glass now is, so that this same image shall be printed on it.

For this purpose we must quit the warm precincts of the cheerful day, and go into the narrow den where the deeds of darkness are done. Its dimensions are of the smallest, and its aspect of the rudest. A feeble yellow flame from a gas-light is all that illuminates it. All round us are troughs and bottles, and water-pipes, and ill-conditioned utensils of various kinds. Everything is blackened with nitrate of silver; every form of spot, of streak, of splash, of spatter, of stain, is to be seen upon the floor, the walls, the shelves, the vessels. Leave all linen behind you, ye who enter here, or at least protect it at every exposed point. Cover your hands in gauntlets of india-rubber, if you would not utter Lady Macbeth's soliloquy over them when they come to the light of day. Defend the nether garments with overalls, such as plain artisans are wont to wear. Button the ancient coat over the candid shirt-front, and hold up the retracted wristbands by elastic bands around the shirt-sleeve above the elbow. Conscience and nitrate of silver are tell-tales that never forget any tampering with them, and the broader the light the darker their record. Now to our work.

(To be continued.)

Correspondence.

PHOTOGRAPHIC REPRODUCTION OF PICTURES.

SIR,—Do you not think that much of the bitterness of feeling between publishers of engravings on one hand, and certain unscrupulous photographers, on the other, might be avoided, and the growing taste of the general public for art fostered and encouraged by the plan I now propose for publishing the works of the celebrated artists of the present day. Suppose one or two, or more, of the leading photographers were to commission one of our best artists to paint an original work in monochrome, with the express understanding that it was to be copied by photography. When the work was finished the London firm could take negatives of the painting, and sell them to photographers in the country, who would agree to sell the prints, of a certain fixed size and at a fixed price. How much better and straightforward this would be than the miserable, sneaking way, of copying engravings, and running all the risk of the pains and penalties attached thereto. Again, how faithfully photography would convey the imprint of the artist's mind, even to the very touch and manner of the painter.

As one instance of the value of photography in reproducing the work of the artist, look at the woodcut in the

Illustrated London News, of the painting of Caesar leaving the palace after the burning of Rome,* and look at the photograph of the same by the London Stereoscopic Company. The former gives no idea of the distance—the latter gives it in its most perfect form. So far as I have seen, all engravings seem deficient in this respect, from a woodcut in a newspaper to a fine line engraving; the effect of distance does not seem to me to be rendered near so truly as by a good painting or photograph. Of course, this case is an extreme one, and not a fair comparison; still, it may serve, as being so familiar to many of your readers.—Yours, truly,

THOS. GULLIVER.

Union Street, Swansea.

Photographic Notes and Queries.

WEAK PRINTING, BATHS.

SIR,—Under the above heading, one of your correspondents, who adopted the *nom de plume* of "Publicolo," published in your *News*, of the 24th of April last, a recipe as follows—silver 20 grains, nitrate of soda 60 grains, to 1 ounce of water. From the day I received your journal of that date up to the present, I have used no other bath for my papers. I have never had a mealy picture, and but once have had occasion to clean my bath with kaolin. I have used about a dozen 5 by 4 papers daily, and beg to enclose you a specimen. Amongst the many excellent suggestions published in your columns, none have been more valuable in a monetary sense than the above.—Yours obediently,

AN AMATEUR.

[The print received is a brilliant, well toned print, quite free from mealiness.—ED.]

ON CERTAIN STATES OF THE ATMOSPHERE WITH RESPECT TO ACTINISM.

SIR,—In reply to Mr. Warner's question as to the amount of actinism during the early part of this month, permit me to state that I was taking *carte de visite* portraits here (about twenty miles north of Ross), on the 6th, 7th, and 8th of July, and my experience was quite the reverse of his. I never met with finer weather for the purpose, having obtained negative after negative in the open air, showing no trace of under exposure in the details of foliage in the background, with exposures of from one and a half to two seconds. Amon. sulph. of iron developer, and in most cases only one application, no intensifying being required. The collodion, Home and Thornthwaite's new bromo-iodized, of which I can speak quite as highly as Mr. Warner does; the lens, an excellent C. de V., by Mr. Cox; the bath, an old one intended for the Pothergill process, and not intended for very rapid work.

I may, perhaps, take this opportunity of mentioning a circumstance of the kind alluded to by Mr. Warner, which happened to myself last autumn. Some friends had appointed to come here on a certain afternoon to be photographed for a relative in India. Being desirous of producing a good result I took all the usual precautions, carefully preparing fresh developing solutions, testing the bath, &c. About mid-day the weather began to get rather dull, yet I thought longer exposure would enable us to take good pictures. However, on trial I found that no exposure, however long (and at last I gave exposures with the full aperture of a portrait combination, which would have been considered long with a landscape lens and small stop), would produce anything beyond the faintest trace of a positive. We were obliged to give it up after several trials, and I took the precaution of setting aside the bath and remaining developer for trial next afternoon, at the same hour, when everything went well, and good negatives were obtained with the same collodion and chemicals which had failed so utterly the day before.

On examining the atmosphere after our defeat, I fancied that I could detect amongst the trees a very thin, faint haze, of a peculiar greenish yellow hue, such as I have never seen before or since; but, imagination is apt to play one tricks on such occasions, and I shall be glad to learn whether any one else has noticed the appearance I mention.

It would be well if all photographers who experience this mysterious phenomenon, would publish an account of the occurrence in one of the journals; several instances are already

* Shown in the International Exhibition.

before the public, the first, unless I mistake, being described incidentally in a paper by Mr. Rejlander before the Photographic Society of London some years back. Comparison of numerous independent observations might lead to most interesting and unexpected results. At present we have too little to base theories upon, all we can do is to observe, and record faithfully what we see.—I am, Sir, yours most truly, ROBERT DOUGLAS.

Stoke Laey Rectory, Bromyard, July 14th, 1863.

DEAR SIR,—In last week's NEWS I saw a letter from Mr. Warner, respecting the non-actinic weather lately. Curious enough, when the NEWS came to hand, I was just about writing to you on the subject; as, during the past week or ten days, I had experienced in a marked degree all that Mr. Warner complains of.

I found that I had to give nearly four times as long exposures as I usually do, for the wet process, tannin, and Dr. Norris's plates, and also for chloridized paper. I also noticed that albumenized paper decomposed much more rapidly than usual after being sensitized.

The want of actinism in the light might be accounted for on some of the days referred to by the absence of clouds—but, clouds or no clouds, it seemed very nearly the same.—I am, yours truly,

H. COOPER, JUN.

[We have had verbal communications from photographers of eminence, noticing the same phenomenon. The extreme dryness of the atmosphere appears to be generally regarded as the cause. The rapid decomposition or discolouration of excited paper is a singular concomitant, of which also we have had several complaints. Dryness would generally retard this, but we presume the extreme heat has acted even in the absence of moisture.—ED.]

DEAR SIR,—Having read Mr. Warner's remarks upon non-actinic weather, in the NEWS of the 10th instant, and being one of your numerous readers, my reply to that gentleman's inquiries is at your service.

I have experienced the same inconvenience from the peculiarities in the state of the atmosphere at Ipswich of which he writes.

It occurred immediately after a very severe thunder-storm which took place on the night of the 24th of June, and has continued until this morning when the usual actinic power seemed to return, and has continued throughout the day with excellent results.

It appears to me that Mr. W.'s idea of a want of electricity in the atmosphere is a correct one, and quite sufficient to account for many troubles and perplexities to which photographers are subject.—I am, dear sir, yours truly,

J. STOKES.

SIR,—I can fully bear out Mr. Warner's statements regarding the present want of actinism. Indeed, on several occasions during the last three weeks, I have found it all but impossible to get a picture. Yesterday, at 6.30 p.m., I took a negative with an exposure of 15 seconds, but in the middle of the day I had to expose for 25 or 30 seconds, and even that was scarcely sufficient. I am quite unable to account for the change, as the sky was bright and cloudless the whole day.

I ought to mention that I used the same collodion, developer, &c., as well as the same sized stop. In the middle of the day the negatives required a great deal of intensifying, but the one taken in the evening came up strong and brilliant with iron only. On all the negatives I have observed a very peculiar deposit; by reflected light the shadows seem quite buried, but by transmitted light they are quite clear, and the deposit does not seem in any way to affect the printing qualities of the negative. Unless my experiments mislead me, there is at present in the atmosphere much less than the normal quantity of ozone. Might not that be the cause of our difficulties?—I remain, yours truly,

JAMES MUNRO.

DEAR SIR,—Allow me to inform Mr. Warner that my experience of the photographic influence of the atmosphere here has corresponded generally with his, with the exception of a day or two. There has been at times heavy fogs arising suddenly; and, on some days, the evening has closed sooner than usual, although the weather was fine. I think I remember to have read, that in some countries when the sun produces great heat, and the atmosphere is very dry, that exposures are required to be much lengthened, compared with those required in this

country in general; may not the decreased density, or the absorption of gases drawn from the earth so alter the quality of the atmosphere as to greatly reduce its actinic properties? Sick headaches, and pains in the head have been prevalent, which will be accounted for by the great heat causing a too sudden increase of the circulation of the blood to the brain; care should be taken to avoid exposure to the sun's rays during the middle of the day.—I am, dear Sir, yours truly,

T. MARTIN.

PHOTO-ZINCOGRAPHY AND PHOTO-PAPYROGRAPHY.—A correspondent of the *Athenæum* writes:—"It is curious to note, whenever the properties of any substance (if light can be so designated) have been discovered, and the students of the science are intent upon multiplying the variety of its applications, how by apparent accident, and sometimes coincidentally, the phenomena of a new art are suggested to persons widely sundered by place and circumstances. Colonel Sir Henry James, at Southampton, and Mr. Osborne, at the antipodes (Melbourne), hit upon the zincograph in the same month: the latter obtaining for his invention a patent, with a reward of £1,000 from the spirited and munificent Government of Victoria; Colonel James and his accomplished subordinate, Captain A. De C. Scott, resting content under the conscious sense of public usefulness with the honour conferred by the noble and enlightened of all lands. In December, 1859, an ingenious young lady asks Sir Henry how she could get her etchings cheaply printed; and he takes one of them to the Ordnance Office, at Southampton, submits it to the chromo-carbon process, and transfers the imprint to the zinc plate. This was the first zincograph. Again, shortly afterwards, one of the workmen having, by mistake, laid the ink on the wrong side of the paper, thus giving a reversed outline, Sir Henry obtains from this negative on paper a copy of the original, and ascertains that the negative can be printed on paper instead of glass. Here was the first papyrograph. Now, by these discoveries, we possess the means of reproducing, with a fidelity, cheapness, and durability hitherto unattained, copies of any subject, unaltered, enlarged, or reduced in size, and with every gradation of shade or tone; for the lithographic ink used, of which the main ingredient is pure carbon, is, like the carbonized ink of some of the ancient palimpsests, ineffaceable, except by the destruction of the material on which it is inscribed. In the reduction of plans and maps the greatest deviation by the photographic process did not amount to 1-400th part of an inch in the rectangle; and even this minute error is not cumulative, and can be estimated with mathematical accuracy, if required. With deeds, MSS., and all artistic and natural objects, so minute a deviation would, even if appreciable, be of no consequence. It would not be admissible to detail here the modes and manipulation of these novel appliances of photography, which afford to all the learned professions, as well as the workers in every employment, useful and ornamental, advantages as widely diffused as the very light which is their intervenient instrument; but the manipulation is not so difficult, nor the materials so expensive, as to prevent the practice of photo-zincography and photo-papyrography, even by lady amateurs, who would wish to furnish their drawing-rooms with fac-similes of objects of rare beauty and elegance, whether the originals be the productions of their own talent, or gathered from the kingdoms of Nature and of Art."

[Referring to this paragraph, Mr. Osborne wrote the following letter to the editor of the *Athenæum*. No notice having been taken of his communication, he requests us to publish it.]

SIR,—May I be permitted to correct an erroneous statement respecting my photolithographic process which appeared in the *Athenæum* of 6th of June?

In a communication signed John Locke, it is clearly and deliberately asserted that I invented my process in Melbourne in the same month as Colonel Sir Henry James initiated his method at Southampton. This is very far from being the case, mine being several months antecedent to Sir Henry's process, as it dates from the 19th of August, 1859, and the publication of maps by it commenced at the Department of Lands and Survey on the 3rd of September following. Bearing in mind the circumstances under which my invention was made, I attach considerable importance to my hitherto undisputed priority, and trust you will favour me by giving publicity to these few words in explanation of the present mistake.—Yours obediently,

J. W. OSBORNE.

67, Potsdamer St. Berlin, 13th June, 1863.

Talk in the Studio.

TRANSFERRING FILMS.—A valued correspondent, Mr. T. Barrett, says:—"I think the great objection to the method of transferring the collodion film to paper, described in the last number of the NEWS, is this, that the printing must be through the paper, which must materially diminish the sharpness of the print. Now, the method of transfer which I described a long time back, is free from this objection, as the film, being removed from the glass by means of gutta-percha dissolved in benzole, is attached to the paper on the same side that was next the glass. The process is very easy and simple."

SOUTH LONDON PHOTOGRAPHIC SOCIETY'S ANNUAL DINNER.—The members of the South London Photographic Society dined together on Saturday last, at the "Eagle," Snaresbrook, Epping Forest. They enjoyed an excellent dinner, made speeches, and drank toasts, but did not discover the source of the photographic Nile. We need not, therefore, enter into further details of the meeting.

To Correspondents.

METRIC.—All that we can say with certainty of the two transferred films is that they are fogged. Whether this be due to the condition of the bath, exposure to diffused light, or the use of a hot developer is uncertain. We should be much disposed to attribute it to the latter cause. A hot developer is not suited to plates containing any free nitrate, as those by Mr. Keene's process do. 2. The mottled effect in the print is due to imperfect fixation, arising from the use of an old or weak solution of hyposulphite, or too short immersion. 3. Of the samples of glass enclosed No. 4 is best suited for a dark-room, as it cuts off all the blue and a large portion of the green rays.

AMATEUR IN ST. THOMAS, W. I.—There is no work published on the manufacture of photographic chemicals, nor can we recommend you to any work on manufacturing chemistry of an extremely simple character. The articles on "Photographic Chemicals," at present in progress in our pages, were undertaken to supply the want you express, and you will probably obtain all the information you require, either from the articles already published or those which will in due course appear. "Gmelin's Chemistry" is one of the best works for general reference.

AN OLD SUB.—Creosote and benzole are essentially different bodies both in their properties and origin, although they possess some analogies in both. Creosote is a preparation obtained by a complicated process from wood-tar, and is most remarkable for its antiseptic properties. Benzole is obtained by the distillation of coal-tar, and is a valuable solvent for gutta-percha, india-rubber, and various resins. Kerosene is a preparation recently introduced of a similar character, and is, we believe, obtained by distillation from wood-tar.

MEALINESS.—Some varieties of paper are more disposed to the production of mealiness than others, but in the examples sent we fancy the negatives are chiefly chargeable. The old print sent to show absence of mealiness is decidedly mealy; but being from a bright negative it does not show the fault in an offensive degree. The print sent as being mealy is apparently from a less brilliant negative, and is not sufficiently printed. When the tendency to mealiness is present use the toning bath weaker and older; this is the best remedy we know. We will endeavour to try the piece of paper sent when occasion serves. See Mr. Parkinson's toning formula in the present number; but remember that we in no case counsel the use of a lime bath until it is a few days old.

N. G.—The cause of the yellowness in your print is imperfect fixation. The hypo bath is too weak, too old, the print has not been in a sufficient length of time, or it has been stuck to another, and so has not been sufficiently acted upon by the solution.

DUNCAN.—The "frosted" effect of which you speak in many stereoscopic slides arises from slight under-exposure and over-development in the negative. The result is an excess of vigour trenching upon hardness, which, whilst it only appears to give brilliancy to the print, when examined as a picture on a flat surface, appears snowy in the stereoscope. Very soft prints full of detail are best for stereoscopic effects, and many pictures which appear tame, flat, and wanting in force out of the stereoscope, are quite perfect when examined by its aid.

D. SMITH.—The black spots to which you refer might arise from a variety of causes, but without an example of the especial kind of spot, we cannot offer suggestions as to the cause, without occupying too much space. It is certainly desirable to have the developing room, the table, &c., free from any kind of loose particles, which might come in contact with the negative in any stage of its production. In exposing your bath you do not state whether you neutralized it first. The best plan is to proceed as follows: first neutralize the bath by adding a solution of bicarbonate of soda cautiously, a little at a time, until there is a slight permanent precipitate. If it have been giving pin-holes in the negatives, it is probable that it is supersaturated with iodide, to get rid of which dilute the solution with its own bulk of distilled water, which will make it turbid, or milky, by the precipitation of iodide. Now, expose the whole for a few hours to a bright sun; then filter out the black precipitate, add sufficient nitrate of silver to make up the strength, and try a plate. If there be any trace of fogging, add a drop or two of nitric acid. As we cannot with certainty follow the history of your bath through all its stages, we have repeated the proper steps to be taken. Never add ammonia to your negative bath, it will introduce you to many troubles. The collodion of which you speak as very tender has proved in our hands very tough and adherent. 2. With regard to the printing bath, there are several efficient means of removing the colour. Kaolin may be used; we prefer the use of a little of a solution of common salt. That does, as you remark, precipi-

tate a little silver as chloride, but it takes down with it the colouring matter at the same time. 3. The silver bath into which glue was dropped may be purified by neutralizing and sunning, and so with the other to which you refer; sometimes a long sunning is necessary to precipitate all foreign matter present. 4. The mottled effect of the prints received is due to mealiness. Use a weaker and older toning bath. The prints are not sharp. Your lens is in fault, or it is not focussed carefully.

A FINE WEATHER TOURIST.—Where rapidity is unimportant, and good keeping qualities imperative, the best dry processes are the collodio-albumen and the tannin. If simplicity of preparation be an object the latter is preferable; but if the best, most certain results, without reference to trouble, be the consideration, then we should prefer the collodio-albumen. 2. The tannin process, as employed by Mr. Hurst, is, we believe, so far as the preparation of the plates is concerned, the tannin process in its simplicity as originally propounded: plates with preliminary coating of gelatine; coated with a bromo-iodized collodion; excited in slightly acid bath; well washed; and coated with 15-grain solution of tannin. His mode of securing rapidity is by a modification of the developer which we are not at present at liberty to publish.

A SUBSCRIBER.—Plates prepared by the honey process ought not to be immersed in the nitrate bath before development, but simply moistened with distilled water. We cannot speak of the respective merits of the samples of bromo-iodized collodion to which you refer; but think it very probable that any of them would answer. The spots to which you refer as occurring on honey plates most likely arise from dust having settled on the tacky surface.

A LADY OPERATOR.—If you use India-rubber finger-stalls to protect the fingers from stains whilst developing, take care not to let them come into contact with hypo, as that would probably cause a stain on developing the next plate. It is well to keep the finger stalls for development only; but if you use them whilst performing other operations make it a point to frequently rinse them.

M. A. P.—It is very probable that if you announce the business for sale in our advertising columns, you will meet with various applicants to purchase. The value of the business will necessarily depend upon many circumstances, and especially on the annual amount of profit realized. From your description it is a property which will find ready sale.

THOMAS KIRBY.—In neutralizing the free hydrochloric acid in making your chloride of gold, the addition of bicarbonate of soda produces chloride of sodium, which is not injurious. But it is a somewhat critical operation, as the slightest excess is apt to produce decomposition, and a precipitate of metallic gold. It is better to drive off the acid by gentle heat, and neutralize any trace left when making the toning bath. 2. The method you employ to prevent the varnish dissolving the film is practically, we imagine, weakening the alcohol: the spirit with which the varnish is made is probably nearly absolute. A portion of this you evaporate, and then add ordinary alcohol, which is much weaker.

ANTHRA SUBSCRIBER.—It is probable that the paper may have been prepared with stale albumen, which would make it more readily decompose, when silvered, in warm weather; or it may have had acetic acid added to the albumen, and this is often a source of rapid discolouration. A trace of nitric acid in the silver bath will aid the paper in preserving its colour. After exciting, keep the paper in a dry, cool place, and that will aid you a little.

P.—You may rest perfectly satisfied that the pursuit of photography, either amateur or professional, is in every way honourable. You will commence with the wet collodion process, of course, and then, if you require it for landscape purposes, give your attention to a dry process. The mentioned supplies cameras, we believe, of excellent quality.

J. GILBERT.—The reason of your acid dissolving the cotton at a temperature of 150° is, that the nitric acid is too weak. Your remedy, if you continue to use the same nitric acid, is to add a larger proportion of sulphuric acid. 2. You will find the method of purifying silver from copper stated at length in the early part of Vol. V. of the PHOTOGRAPHIC NEWS, the Nos. for January 4 and 18, 1861. We are by no means certain that the presence of nitrate of copper in minute traces is detrimental. The manufacture of chloride of gold is very simple: dissolve pure gold in aqua-regia (nitric acid one part, hydrochloric acid two parts), and then evaporate the acids by gentle heat.

A SUBSCRIBER.—The printing of the card received is very good, but the negative is hard. If you can guarantee your employer always equally good prints, you will, probably, find employment as a printer. You are the third correspondent we have to answer this week with the simple signature of "A Subscriber." It is better to use a name more distinctive.

THOMAS BARRETT.—We apprehend that it must have been due to some peculiarity in the collodion which caused it to give crispness on the addition of amber, after Jeanrenaud's formula. We have not had an opportunity of showing the specimen yet. We print your remark on transferring in another column.

NON-ACTING WEATHER.—Mr. W. H. WARNER, of Ross, presents his compliments to the readers of the NEWS, and would feel obliged by their communicating with him direct on any further details on the matter contained in his letter of last week on the above subject. Several correspondents in our next.

Photographs Registered During the Past Week.

- MESSRS. HELSBY AND Co., 34, Church Street, Liverpool,**
Two Photographs—Prince Consort Memorial, Hastings.
- MR. JOHN FREW, Railway Terrace, North Shields, Northumberland,**
Two Photographs—Interior View of Melrose Abbey.
- MESSRS. WINTER AND SON, Beverley, Yorkshire,**
Photograph of the late John Willis, Esq., of Beverley.
- MR. JOHN BEATTIE, Clifton, Bristol,**
Five Photographs of George Thomas, Esq.
- MR. JOHN CHARLES, Brook Street, Chester,**
Two Photographs—View of Roman Hypocaust discovered in Chester, 1863.
- MR. WILLIAM HARDING WARNER, Ross, Herefordshire,**
Photograph of Rev. — Keene.

THE PHOTOGRAPHIC NEWS.

Vol. VII. No. 255.—July 24, 1863.

CONTENTS.

	PAGE
Photography in Paris.—Portraiture	349
Scientific Gossip.....	350
Toning Baths	351
A Few Words in Favour of an Old Friend.—The Malt Process. By F. T. Fassitt	352
The Aesthetics of Portraiture. By M. Disderi	353
Preparation of Sulphocyanide of Ammonium. By E. Millon ..	354
Doings of the Sunbeam.....	354

	PAGE
Proceedings of Societies—Amateur Photographic Association ...	356
Correspondence—Foreign Science—What a Lens will Cover, &c. —The Lime Toning Bath and its Difficulties	356
Photographic Notes and Queries—Old Iron Developer v. New— Fogging Nitrate Baths	358
Talk in the Studio	359
To Correspondents.....	360
Photographs Registered during the past Week	360

PHOTOGRAPHY IN PARIS.

PORTRAITURE.

It has often been remarked—indeed, it has become a generally recognized fact, that the French photographers especially excel in the delineation of the human figure, in all kinds of portraiture. We find all kinds of portraits, from the *carte de visite* to the full length life size, executed equally well. Delicacy, roundness, softness, and vigour characterize most of their photography. Ease and grace are common in the positions, and, with some few exceptions, the accessories and general arrangement of the sitter are spirited and effective, without being theatrical. There is a greater variety of style and effect, and less of the commonplace, than we find in this country. The examination of many portraits, either in an exhibition or in the atelier of an artist, generally becomes tedious, if prolonged. But, in Paris, the variety of style, size, subject, and treatment keeps alive the interest satisfactorily.

In the exhibition, for instance, one artist shows chiefly fine card portraits, with great variety of treatment. Another exhibits a frame of exquisite vignette heads, of 5 by 4 plates. Then we have the life-size busts of Alophe, taken direct, without enlargement. These are not to our taste, but still they are wonderfully bold and round, and, considering the method, wonderfully free from coarseness. There appears to be some degree of mystery as to the method of producing these. They are styled untouched, and taken direct, but it is said that the negatives are much worked upon by M. Alophe, who was a painter before he became photographer. It must be remembered, however, that in working upon a negative, lights only can be put in—it would be impossible to increase the depth of shadows. The density of some parts may be increased by pigment, but not decreased. Be this as it may, the pictures are marvellously effective, but to us not so pleasing as a good solar camera enlargement. Next we find a screen of most excellent photographs on whole plates, in which each portrait is surrounded by a singular *entourage*, in the shape of a photographic frame, forming part of the picture. The sitter has been practically framed, or placed in a very rich and elaborately designed picture frame, through which he looks. The effect is singular and striking, but scarcely artistic. The photography is very exquisite, especially round, soft, and well modelled, and the positions are good. Were it not that all is so well done we fear the effect of this *entourage* to the figure would be vulgar. We have next the spirited whole-plate and ten by eight portraits, by Adam Solomon, sculptor and photographer; and pictures of the same class, by Pierre Petit, all fine studies of pose and excellent specimens of photography, but many of them spoiled by unnecessary touching. Numa Blanc adds to the interest of his fine portraits by stating that the enlargements were effected by aid of the electric light, by which also, by the way, Nadar's photographs of the catacombs were obtained. Other distinctive characteristics giving interest to the portraits might be mentioned, but it is not necessary to enlarge further.

Amongst the first, perhaps *the* first, portrait establishments in Paris, is that of M. Disderi. A brief sketch of what we observed there may be interesting to our readers. One of the most noticeable features of the establishment was the number and excellence of the solar camera enlargements, of every size and style, from the bust half life size to the full-length standing figure of the real proportions of nature; from the simple untouched photograph, to the most elaborately-finished oil painting. All the enlargements appeared to be exceedingly perfect, those untouched as well as the most highly finished. There was an absence of the coarse black and white effect, without modelling, which we have seen in many solar camera pictures; and an equal absence of the feeble, flat, grey, ill-defined pictures which other artists produce with the same instrument. A full-length life-size of an officer in uniform appeared to us almost perfect, and so far as we could judge, untouched. The handsome suite of reception rooms was crowded with excellent specimens of art and photography, produced by the aid of the solar camera. The enlargements, we were informed, are not effected in Paris, but in Toulon, where M. Disderi has an establishment for this and similar work in which a pure and actinic light is of great importance, the ordinary printing establishment being in the immediate neighbourhood of Paris, at St. Cloud, if we remember aright.

Ascending to the ateliers, M. Lacan again kindly officiating as *eiccone*, we find M. Disderi actively engaged in the posing and arrangement of sitters. The glass-room is large and spacious, having top light and side light, all front light being carefully cut off. The space not immediately in use is filled with a large profusion of accessories, well designed articles of furniture, and toys to attract the attention of children. M. Disderi's management of the sitter is an admirable embodiment of the principles he lays down in the valuable and interesting article on the "Aesthetics of Portraiture," which is concluded in the present number of the PHOTOGRAPHIC NEWS. The general arrangement of background and accessories having been secured, M. Disderi places himself in the position he desires his model to assume. The sitter does his best to imitate the position, and if he fail, his awkwardness is pointed out to him with good-humoured raillery, sometimes accompanied by pantomime, illustrating the awkward effect produced. There is no attempt to twist the head, body, or limbs into the desired position; but the sitter is requested to move away, and then begin *de novo*. There is little danger, therefore, of the twisted, stiff, anxious look too often seen in photographic portraits. The effect of placing the sitter in position, and attempting to get the right view by a series of little modifications requiring a few minutes to make, generally results in great fatigue to the sitter, and an utter want of grace or ease in the picture. M. Disderi's aim appears to be to avoid producing fatigue, anxiety, and depression in the sitter, and in this he seems very successful. His operations in arrangement are, moreover, exceedingly rapid, which materially adds in preventing fatigue to the sitter. Three negatives for

which, at his request, we stood, only occupied about as many minutes, although the exposure was fourteen seconds.

The lens employed was a French one of about twelve inches focus. The distance of the sitter for card portraits, full-length figures was, so far as we could measure by the eye, about thirty feet. We may here remark, however, that a custom is beginning to prevail in Paris of avoiding full-length figures in portraits of gentlemen. Instead of the full-length, about three-quarters of the figure are given, the great difficulty of arranging, with pictorial effect, the trousered legs of the male figure is thus avoided. The distance for these sizes was about twenty feet. One lens only was used, but the plates were twelve by ten, and contained eight on one plate. To English photographers it will probably appear odd that plates of this size should be used whilst two or three negatives only of each sitter are taken, several different persons being thus taken on one plate. Notwithstanding the celerity of the operations, it must often happen that the arrangement and posing of two or three different persons, must occupy a space of from twenty minutes to half an hour, during which time the sensitive plate, in very hot weather, apparently keeps in good condition, as we saw no signs of stains or other bad results.

Entering the dark room, another circumstance strikes us as novel to English photographers: the nitrate bath is not upright, but a large flat dish. The solution is tilted to one end, and the plate placed, face upwards, on the bottom of the dish, which is then lowered into the horizontal position, and the solution brought in an even wave over its face. After standing a few seconds the dish is well rocked, so as to equalize the action, and prevent the settlement of any loose particles of dust, &c., from becoming attached to the film.

The collodion is freely bromized, more so, however, in winter than in summer. The silver bath for summer use is about thirty grains to the ounce, or six per cent. In winter it is used stronger. The developing solution used contains twenty grains of protosulphate of iron, and twenty minims of acetic acid to the ounce of water. The negative produced by these solutions give a tolerably vigorous image with the iron alone; but when further intensifying is required it is effected by an application of the same iron solution, to which a few drops of a fifteen-grain silver solution is added. M. Disderi informed us, referring to the developer, that he had never used pyrogallic acid for development at all, having employed iron from his first trial of the collodion process. The negatives we saw were all clean, brilliant, soft and well modelled, possessing, in fact, those qualities which have made the name of Disderi celebrated all over the world.

Scientific Gossip.

WHITE LEAD AND ZINC WHITE—IS ANYTHING OPAQUE?—LIGHT ONLY EXISTS IN THE EYE.

EVERY artist who has been troubled with the rapid sulphuration of white lead, and has been obliged to resort to the employment of zinc white in order to prevent the high lights of his painting from gradually darkening, has noticed that whilst equally white in appearance the white lead possesses considerably more *body* than the zinc white. Whence arises this difference? What is the meaning of the term *body* as applied to pigments? How is it that of two powders, apparently equal in their colour and brilliancy, one looks feeble and transparent when employed as a paint, whilst the other shines out with redoubled vigour? Such questions as these cannot fail to have suggested themselves to many persons, and have elicited a variety of answers. Mr. Barnard S. Proctor has lately made these and other similar questions the text for some very interesting as well as philosophical reflections upon some phenomena of light which have struck us as being so valuable, both on account of the recondite facts they deal with and the popular way in which they are

discussed, that we are induced to give a brief outline of them to our readers. "As white as fine linen, flour, chalk," "as white as snow," are frequent comparisons, but they are all dull examples as compared to many chemical precipitates. Precipitated chalk far outshines the natural varieties, and fine qualities of magnesia carbonate surpass this. Microscopic examination indicates that this latter consists of particles, clear and colourless, but very minute. White lead consists of particles equally minute and also transparent, but of a yellow brown colour by transmitted light; consequently, when seen in bulk it appears of a less pure white. But magnesia cannot be used as a pigment because it possesses no *body*, and the difference between the white lead and the magnesia in this respect depends upon the different refractive powers of the individual particles which compose the separate powders. They are both transparent in their individual particles, but the magnesia is more so. They are both bodies possessed of considerable refractive power, but the lead is more so. When air intervenes between their particles the reflective power of both so much exceeds that of air that they are highly reflecting and very slightly transmitting; but the less absorbing power of the magnesia makes it the whitest—the more reflecting of the two. But when oil intervenes, as would be the case if they were used for pigments, the refractive power of the magnesia so nearly coincides with that of the oil that much transmission and little reflection is the result, and this constitutes what painters call want of *body*. But the lead so greatly exceeds the oil in refracting power that its reflective property is not much interfered with, and even with its greater absorbing power it reflects much and transmits little light; and this is what painters call great *body*.

Another question which must often occur to our readers, and which has been ingeniously discussed by Mr. Proctor, is, whether anything is opaque. This can only be answered inductively from the results of numerous observations. Glass is only approximately transparent, for, if looked through edgewise, we find it stops a great deal of light. It is not so transparent as pure water, and even this, as has been shown by Tyndall, has a blue-green colour when light is passed through fifteen feet of it. Even air is far from transmitting all the light which enters it. A comet is almost incalculably more transparent than the earth's atmosphere. The light of a star passing through hundreds of thousands of miles of a comet's atmosphere and nucleus, loses less light than in passing through the thin stratum of air which covers the earth; yet even the comet is imperfectly transparent, and we do not know whether even the luminiferous ether itself allows the passage of light without some loss, but we know that glass is as much opaque compared with it as gold is when compared with glass; and from this we readily learn to believe that transparency and opacity are only comparative terms—that nothing transmits all the light, and nothing is entirely impervious to light; and this supposition is confirmed by experience. Even metals, which are usually taken as types of opacity, transmit light in thin films; and each metal has a proper colour of its own: thus, gold leaf viewed by transmitted light looks green, brown, violet, red, purple, or blue, according to the thickness of the film; silver leaf is grey-violet, purple, or brown; copper is green, antimony is grey, arsenic is brown, platinum grey, palladium grey, rhodium blue or brown, and charcoal grey. These illustrations show that most bodies transmit a coloured light, the colour deepening as the thickness increases, until it is so dark that we call it opaque. Not long ago light was believed to be reflected from the *surfaces* of bodies. And *now* it is only when we are on our guard that we bear in mind the thickness of matter required to reflect a ray. We know that in a soap-bubble we often see patches so thin that they do not reflect light, though they are still possessed of two surfaces. Faraday observed that some of the gold films he experimented with when reduced very thin by chemical means, lost part of their reflecting power, though they continued to be free from any material injury to their surface or integrity,

proving that some depth of matter is concerned in ordinary reflection. Different kinds of reflecting surfaces have different appearances; this is probably due to the effect produced upon the light by its passage into and out of that thickness of matter which is concerned in ordinary reflection. Of homogeneous matter, opaque gives metallic lustre and transparent gives vitreous; as a general rule, if not universal, we find the more nearly a substance approaches the metals in opacity the more it resembles them in the nature of its lustre. Thus sulphides are in many cases very nearly opaque, and very like metals in the nature of their lustre.

Some strangely interesting conclusions can be deduced from a consideration of the length of the waves of light in different media. The length of an undulation of violet light is seventeen millionths of an inch; the red undulation is twenty-six millionths; undulations longer or shorter than these not being visible. Again, the length of the light wave varies in the medium. An undulation in air measuring four will measure only two and a half when it enters glass, and will again elongate to its former measure on its exit. When an undulation passes from air into water, or into the humours of the eye it likewise becomes shortened. If we say that luminous undulations, which in air measure twenty-two millionths of an inch look yellow when they enter the eye, (that being the wave length belonging to what we call yellow light) we must also remember that they measure one-third less in that organ in consequence of its refracting power. We then come to the singular conclusion that the blue sky is yellow, sunshine is red, and the rosy tints of evening are not luminous at all till they enter the eye. If the colour depends upon the length of the light wave, and the length of the wave depends upon the refracting power of the medium through which it is passing, every beam of light changes colour; red it may be on its passing through the region of the stars, yellow or green it may be when it enters our earth's atmosphere, blue or violet when it enters water, non-luminous as it passes through glass. But if light which we perceive as violet while it exists in the aqueous humour of the eye was red originally, what colour must that light be which we perceive is red? Its undulations in air must be too long to be luminous at all. This introduces us to the solemn thought that all this vast universe is dark! Light only exists in the eye. It is only a sensation, a perception of that which in nature exists as a force capable of producing a sensation.

TONING BATHS.

During the past four or five years a great variety of toning baths have been proposed. Every one has plumed himself upon his own particular method—sometimes a secret one, but always assuming that it is superior to those of his neighbours. This state of affairs has led to a host of toning baths, which depart more or less from the conditions demanded by photographers, especially by amateurs, who, working less, do not obtain uniform results.

A toning bath, to be really good, must be *simple in composition, easy to use, successful in its results, and as economical as possible.*

Moreover, for albumenized paper, it must leave the albumen film as white and pure as before toning, and give in the half tones a colouring which is a lighter tone of the full colour. A taste, which we may venture to call a false one, has for a long time prevailed; it is that of giving to all commercial photographs a blue-black hue. By this the resemblance which constitutes the privilege of photographers, is lost. Thus chestnut or red hair is transformed into black, and it is seldom that this transformation does not destroy the resemblance to the original.

To gratify this vicious taste, it has been necessary to employ very deep printing, and strong toning; the light tones then disappear, leaving pure whites in the figures. These photographers, led away by a vicious example, degrade

photography, and cause it to imitate printing ink of a lithograph or mezzo-tint, at least, with this difference, which is supreme—the suppression of the half tone represented by the stipple of the engraver or the grain of the stone.

The precedent supplied was by the bath of M. Legray, now of bad repute, and entirely rejected, shows us the inconvenience of prescribing a bath without explaining its use, and without determining the operations which precede the toning.

The bath in question was a good one at the time it appeared, and it is so still, when the following recommendations are observed:—

1. The paper must be thick and strongly chlorinated.
2. The nitrate bath must be 20 per cent., and the paper floated upon it from six to eight minutes.
3. The proof must be immersed in the toning bath without previous washing.

These three recommendations demand a few words of re-consideration.

Thick paper absorbs a very great quantity of nitrate, a concentrated silver bath leaves a layer of nitrate on the surface of the paper, and when the proof is put into a toning bath, the 3 parts of chloride of lime to 1,000 parts of liquid, go in part to the nitrate to form chloride of silver, and thus remove from this bath its devouring power.

It is also to be remarked that it must be employed only in small quantity, just sufficient to cover the proof. It is more than probable that the paper was dried at the fire.

Some years ago, papers were thicker, and more strongly chlorinated. Concentrated baths were all the rage, and negatives developed with pyrogallic acid were almost all veiled or at least very hard. The proofs were exposed for hours in the sun, and were really printed in the papers. But we have changed all that. Now-a-days we must have thin paper of the finest grain. The strength of the baths has diminished, for this great quantity of chloride was not necessary. Negatives are developed with sulphate of iron, and are more transparent. The great demand for *carte de visite* portraits has compelled photographers to reduce the time of printing.

From the preceding we perceive that to judge of a formula it is quite essential that we should be placed in the same conditions as the author of it.

It is the want of development in the description of the process which causes all the failures; the consequence is a very legitimate hesitation on the part of the operator to try new formulae.

The authors of formulae for toning baths too often forget to indicate the conditions in which the paper must be placed in order to obtain all the effects promised from the bath they prescribe.

The paste of the paper is necessarily acid at various stages of its fabrication; from the variable degree of acidity to the starting point proceeds the multitude of toning baths, which are all indistinctly good with the papers for which they have been prepared.

The preparers of papers making use of papers more or less alkaline, sometimes in the inverse sense of their degree of acidity, thus furnish to photographers papers of which the series of the degree of acidity or alkalinity differ entirely from the composition of their toning bath.

The photographer, in his turn, changes this state of things by employing acid, alkaline, or neutral silver baths. He concludes his operations by a toning bath of *fixed* proportions, and is astonished at not having a constant result.

It would be much more astonishing if such marked differences gave similar results.

If the manufacturer could give us a neutral paper, we should require the preparer to deliver it to us in a neutral state also. We should then place it ourselves in conditions proper to receive the action of our toning baths.

This starting point not being obtained, it would be very difficult to require of the preparer to make a chemical analysis to ascertain the state of the paper, either before or

after preparation. The present state of things being chronic, what should the photographer do?

The reply, we believe, ought to be made as follows.

Render your toning baths more or less alkaline by increasing or diminishing the alkaline substance according as you may judge suitable for the paper you possess.

To be able to determine the proportions, the operator must resign himself to the task of testing a supply of paper, and obtain from the manufacturer and preparer a ream of paper, the pulp of which is identical, and the preparation of which has brought it, from time, to its normal state.

A ream of paper may be supplied so that the first sheet will be in exactly the same conditions as the last. The preparer, in albumenizing it, cannot deliver it to us in analogous conditions. He can supply a series of sheets exactly the same; but the first series will differ so much the more from the last in proportion as he has waited longer to restore his bath to its original position.

With manufacturers, an operation is performed which is the primary cause of all our vexation with respect to the paper; this operation is the *trriage*. Five, ten, or fifteen women, according to the extent of the factory, are charged with removing the sheets of paper to the drying room to put them into piles and form reams. One of the women turns first to the right and then to the left, piling and forming a ream of entirely different elements. A similar operation at the preparers still further removes the homogeneity that first existed.

One cause of failure most often to be dreaded is the yellow tint of the paper in the whites of the proof. It proceeds from various causes, one of which is the solarization of the paper before it is nitrated.

M. Niepce's experiments have shown us the *storing up* of the luminous rays, their retention and activity still existing after the lapse of several months. It is this solarization, so formidable in summer, which is the cause of those uniform yellow tints which the paper acquires before being put into the pressure-frame. Another solarization, less common, is that produced by the rays returned by solarized proofs placed in heaps when none are fixed. The nitrate baths, under the influence of organic bodies, also acquire an activity capable of yellowing the papers, and without apparent cause, they come out of the bath yellow in proportion to the activity of the cause.

Albuminous papers, either old or of bad quality, also acquire the property of yellowing, without our being able to trace the cause exactly. Probably, it is the state of the albumen, or of the pulp of the paper employed in its preparation, which causes this inconvenience.

Washing too many proofs in too small a quantity of water, or too prolonged a washing, in a water impregnated with lime, will also cause a yellow tint.

An impure silver bath, or one too strong or too weak, influences the desired tint. A negative too transparent, causing a too rapid solarization, gives also a grey proof in toning.

An incomplete toning, marbled and not uniform, arising sometimes from too great a reduction in the strength of the silver bath, and from too short a time being allowed for the paper to remain in contact with the argentiferous solution. The same effects may be produced when a great many proofs, placed one upon another, are not wholly in contact with the toning bath: bubbles of air, imprisoned between the proofs, form spots less deep in tone than that of the remainder of the proof. This kind of failure may be avoided by placing each couple of proofs back to back, at the bottom of the bath.

Some persons consider that the toning is assisted by not removing the excess of nitrate from the proof before toning, finding that it is of a better tint, and more beautiful. This observation is imperfect, for if this proof had been compared with the others after leaving the hyposulphite, it would have been seen that this fine tint and rapid toning was not preserved, and that the proof was not equal to those which had been slightly washed before toning. Not to wash the proof

is good, perhaps, for a bath the formula of which includes a substance which combines with the nitrate of the proof to aid the toning. This was the case with M. Legray's bath, quoted above.

We perceive that the causes of failure to the toning baths, without taking into account the spurious chloride of gold with which commerce is infected, for, most frequently, the chloride of gold is such only in name: it is either a chloride charged with hydrochloric acid entirely annulling the effect of the alkaline substance, which, with the chloride, composes the bath; or it is a double chloride of gold and soda, or gold and hyposulphite of soda, &c.—*Bulletin Belge de la Photographie*.

(To be continued.)

A FEW WORDS IN FAVOUR OF AN OLD FRIEND. —THE MALT PROCESS.

BY F. T. FASSITT.*

I MAKE the following communication with some degree of diffidence, fearing lest many of your readers will think that I am taking the back track in thus attempting to re-vivify comparatively an old process. I allude to the malt preservative of Mr. MacNair, as described by him in the *Photographic Notes*, 1860; but it is sometimes useful to glance retrospectively over the ground we have traversed, and by comparing our present modes of working with those we have discarded, see if in reality we have bettered ourselves.

Always a friend of progress, I have tried all the preservatives as they came forth, from the sticky abominations of honey, down through the whole category of Madam's preserves and jelly, until I reached the Fothergill; here I broke down and discarded the dry, and resolved to stand by the wet through thick and thin. However, upon the introduction of the malt process I was induced to give it a trial, and the result was so satisfactory that for over a year I worked nothing else, and I must say that during that time I produced the best negative I ever made. Upon the introduction of tannin, I gave it a trial, and found the results good, but in no respect superior to the malt; however, as everyone went head over heels into it, I followed the example, and have worked it with varying success until this spring, when, in company of some of the best amateurs of our city, I took a photographic trip through the northern section of our state. The plates used on this occasion were prepared with the greatest care. Fortunately I took developing solutions with me, and after the first day's work, I tried to develop a plate to which I had given, as I thought, a long exposure, but succeeded in obtaining hardly a trace of the sky; of course I had to stand the bantering of my companions upon the extreme sensitiveness of my plates. The next day, however, we increased the time of exposure, and in the evening I tried to develop some of my friends' plates, with the same result. Siccus, who was one of the party, suggested that I had neglected to put any pyro in the developing solution. Trusting that this might be the case, or that the pyro was at fault, we went on making long exposures and trusting to our resources at home to bring out the latent image; but alas! upon our return we found we were all in the same condition, our plates so insensitive to the actinic influence that neither fuming, carbonate of ammonia, nor hot water were of any avail; and our trip, photographically considered, was a failure.

We now commenced to hear complaints from other tannin workers, and found they were labouring under the same complaint. I now set to work to discover the cause. I changed my collodion and tannin; doctored the bath until everything was in first rate order, and made a few trial plates, and to my horror the result was the same. In my despair I made a visit to the lumber room, disinterred a large black box, for which at one time I had a great affection,—for you

* *American Journal*.

must know, Mr. Editor, that I am an inventive genius, and this black box was nothing more or less than a field apparatus for the wet process, and a very good one it is. I was studying how I could alter it so as to adapt it to the requirements of my whole-sized plates (it was intended for them), for you must know I am an inhabitant of the city of brotherly love, whose happiness, according to Mr. Thompson, consists in having a 6-inch globe lens and a Peace changing box, also that I am domiciled in the house with the quaker door-pull that will not work on Sunday (*vide* Thompson's visit to the city of brotherly love); and I will here state that I intend to discard the refractory bell, and substitute a first rate brass knocker, obtained from the grand emporium of that article, Wall Street, N. Y. Returning to the subject, it here struck me to try and see if by changing the preservative I could make my chemicals work. I prepared that night three malt and three tannin plates, using the same materials; on developing them after the same exposure, much to my surprise, the malt were all good, and tannin all bad. Since that I have made and exposed about twenty malt plates, made with the same chemicals, and they have all turned out good. I am at a loss to what cause to attribute our failure, as each one worked with his own materials, in his own way, and in his own laboratory; the only feature in common was that the plates were all bad.

For the benefit of those of your readers who have not tried the process, I will state briefly some of its advantages over the tannin, and the mode of working: first, from requiring less washing, the plates are more quickly prepared; second, the film adheres much better to the glass, and does not contract or form blisters, as the tannin is sometimes apt to do, particularly on large plates; it also stands the different methods of intensifying much better. The exposure is about the same, if anything, in favour of the malt; but one of its chief advantages is the use of an iron developer, and I find by using what Mr. Blanchard terms his iron intensifier, or the modification of it, as described in your journal of June 15th, that sufficient intensity can be obtained with iron alone, without the subsequent use of pyro or gallic acid and silver. Those of your readers who reside in this city, can save themselves the trouble of preparing the malt solution, by obtaining from the brewery what is termed "sweet wort;" I have used it for a long time, and find it as good as any I can prepare.

To make the malt infusion, take seven ounces of well bruised or ground malt, and digest it with twenty-four ounces of hot water, so that the mixture upon being well stirred will be at a temperature of 155° to 160°; do not let the temperature vary much from that for ten or fifteen minutes; then place the mixture before the fire and let it cool down to 130°, it should have acquired a sweet but not luscious taste, leave it to cool slowly, strain out the malt, and filter. By placing a small lump of camphor in the bottle, and keeping it in a coal vault, or cellar, it will remain fit for use a month or more before using it. Any good collodion will answer; bath same as you use for wet; coat and sensitize plate in the usual manner; on taking it from the bath, lay in a tray containing water, and rock it slightly; then either change the water or lay it in another tray whilst you coat and dip a fresh plate, then take the first plate out, drain for a moment, and pour on the malt solution so that it drives the water before it off the plate; pour on a fresh supply, flow it round a few times, pour off and set the plate up to dry. The last flowing of one plate will answer for the first of another.

To develop, lay the plate for a few minutes in a tray of water to soften the film, and then rinse well under the tap; lay the plate for about one minute in a tray containing enough twenty-grain bath solution to cover the plate; take out and drain as for wet collodion, then apply the iron developer:—

Sulphate of iron	12 to 15 grains
Acetic acid, No. 8	1 drachm
Water	1 ounce.

If sufficient intensity is not obtained, apply a two-grain pyro solution, or saturated solution of gallic acid, to which a few drops of twenty-grain silver solution has been added; the most beautiful result is produced with the latter, by laying the plate, supported at the corners, face downwards in the solution.

I have lately tried the iron intensifier, as given in your journal:—

Nitrate of silver	15 grains
Citric acid... ..	15 "
Water	1 ounce.

A few drops of this added to the iron developer gave all the intensity requisite, with great beauty of detail. The plates develop with great rapidity, and make very brilliant negatives; with regard to their keeping qualities, I have plates now on hand prepared in the above manner eighteen months ago, and they seem to work as well as those freshly made.

For positives on glass the malt is much superior to the tannin, giving a clear picture, the clear portions of the glass being perfectly transparent. I have seen some microscopic enlargements, made to exhibit in the lantern with the calcium light. They were fully equal to any made on albumen. The maker informed me he had tried tannin for the same purpose, but could not get the same result.

I must crave your indulgence for trespassing so much on your valuable space, but if anyone, like myself, shall be helped out of the mire, I shall esteem myself amply repaid. There are other uses of malt which will naturally suggest themselves to the mind of the photographer after a hard day's work, which I need not enlarge upon here, only cautioning them against the too free application of it, as it is liable to fog their impressions.

THE ÆSTHETICS OF PORTRAITURE.*

BY M. DISDERI.

We should omit one of the principal means of rendering a portrait resembling and beautiful, by not speaking of the choice and distribution of the light. It is a well-established fact that certain effects are favourable to some features and unfavourable to others. A clear and bright light will increase the features that are already too prominent, and give a hardness to the expression that does not really exist in the model. Again, if features that are naturally of too indistinct a character, be bathed in a soft, diffused light, they will become extremely undecided. The type is thus nearly effaced, and the resemblance and personality of the model entirely lost. If the light is allowed to fall from above, it will augment the projection of the forehead, throwing an energetic shadow over the eyes. The bridge of the nose, the lower lip, and the chin separate themselves, as it were, in clear lights, from the rest of the face. Such an effect would certainly be very inappropriate for the portrait of a young girl, whose forehead is smooth, profile calm, and of whom the soft blue eyes are the principal charm. Again, it would be too strong for a martial figure, as the thick moustache would throw a shadow over the whole of the lower part of the face, thereby giving a too violent an aspect to the whole.

However, if the artist has understood what we have said with regard to the composition of the portrait, and is willing to conform his lights and shades to the style that he has chosen, he will attain the greatest perfection in beauty and expression. By changing the direction of the light, he will soon perceive that all the different effects produced have different significations. Some are calm, sad, terrible; others graceful, gay, and joyful: each has its particular expression, independently, as it were, of either the nature or arrangement of the subject. It is, therefore, very evident that the general effects of the lights and shades should be appropriate to the character which has been chosen as the most favour-

* Continued from p. 245.

able to the portrait. If the portrait be that of a child, the scene should be conceived in a clear and smiling light, free from heavy and profound shadows. If, however, the portrait be that of a man of firm character, it would be necessary to proceed in quite a different manner, the sombre and ampler masses would be alternated by luminous ones—the shadows powerful, and the lights large and frank.

We will not, however, multiply these examples, as we have said enough to put intelligent and sincere artists in the right path. As to those who are not endowed with the fine sense of art and beauty, and whose only interest in photography is in a lucrative point of view, the enlightened public will sooner or later do them justice.

The reader will readily understand, after what we have just said with regard to the choice and distribution of light, of what great importance the position of the atelier is in photography. By preference, it ought to be constructed on the top of a house, so that no shadow or reflection from any neighbouring object may interfere with the effect chosen by the artist. It should have all the sides and roof of glass, so as to allow the light to penetrate equally from all four quarters and from above. It should also be provided with a system of curtains, some thicker than others, moved independently of each other by means of light pulleys, so as to enable the artist to direct the light at will, and diminish its light and intensity. The roof should form a sharp angle, and the glass should, like the curtains, be of a blue shade, so as to prevent the light being disagreeable to the eyes of the model.

The atelier should also be spacious, and unnumbered by instruments of different kinds, as is very often the case. All the photographic accessories, such as scenes, frames, and the like, should be placed in a neighbouring room, which is kept expressly for that purpose. A few objects of art and one or more comfortable chairs, are all that are required to furnish an atelier.

We will add a few words with regard to the choice of dress in the portrait. We hope that the explanations which we have already given have sufficed to show that the dress should be in keeping with the age, character, and habits of the model, and that the photographer should not always content himself with any costume that may be presented to him, as exaggerated dress is almost sure to spoil the portrait. Here is one case, however, in which no choice is allowed to the photographer, namely, when the person wears a military uniform, or an official dress; here, the exact reproduction of the costume is an essential condition to the resemblance. The operator will, of course, know, from his own taste, how to distribute and arrange the dress of his model, so as to obtain optical unity and beauty. We will here call the attention of the operator to a point on which we have as yet but slightly touched, namely, that all the combinations that we have just enumerated as requisite conditions for obtaining a good portrait, may be rendered of no effect by a false choice of colour in the dress of the model. The colours which are the most luminous to the eye, do not always produce the most energetic effects. For instance—red, orange, and yellow, are almost without action; green acts but feebly; blue and violet are reproduced very promptly. Thus, a person of very fair complexion must not be dressed in either green, orange, or red, as the lights would be too prominent, and the whole portrait would lack energy and detail. The artist is thus obliged to be very particular as to the choice of dress in his model.

Portrait colouring does not belong to the art of photography, and we will, therefore, touch upon it but very slightly. This sort of work should only be confided to special and extremely talented artists. It is not only necessary to avoid losing the resemblance, but the colours used must not be so opaque as to cover and render invisible the shades that have been produced by the light. A photographer who is not a stranger to the laws of colour, may greatly facilitate the task of the painter by a favourable disposition of the lights, tones, &c.

It results, from what we have just read, that it must be difficult to obtain a good portrait in which there is both resemblance and beauty; and that the art of photography can only be acquired by long and constant observation of nature, and patient study. It may be thought that so many difficulties would scarcely meet the exigencies of a production which is required to be rapid and not costly. We would answer, that it is not commerce, but art, that is here implied; and that art seeks after beauty, at whatever price it may be realised. The enlightened part of the public fully appreciates this difference. Why should people address themselves exclusively to photographers who ask the highest prices for their pictures, if not for this reason? The materials and chemical substances are precisely the same in a bad portrait as a good one. The real cause is the same as that which creates the inestimable value of those small pieces of canvas signed "Decamps" and "Delaeroix."

PREPARATION OF SULPHOCYANIDE OF AMMONIUM.

BY E. MILLON.*

Mix 150 ounces of commercial liquor ammonia with 20 ounces of bisulphide of carbon and 150 ounces of alcohol (86 per cent.), and allow it to stand 24 hours. The mixture assumes an orange-yellow colour. After the expiration of the time mentioned, the fluid is well stirred, and then about two-thirds are distilled off. The distillate contains nearly all the alcohol holding in solution much sulphocyanide of ammonium; this alcohol may be used two or three times with fresh quantities of ammonia and sulphide of carbon. The residual third in the retort contains the sulphocyanide of ammonium.

As soon as the alcohol is almost wholly distilled over, the fluid, which before was quite clear, becomes muddy, and at the same time loses its colour. It is then carefully evaporated on an open fire to crystallization. The crystals contain flakes of sulphur, which is removed by solution and filtration. By a second evaporation the salt is obtained in very long crystals and in a very pure condition.

DOINGS OF THE SUNBEAM.†

HERE is a square of crown glass three-fourths as large as a page of the *Atlantic Monthly*, if you happen to know that periodical. Let us brush it carefully, that its surface may be free from dust. Now we take hold of it by the upper left-hand corner and pour some of this thin syrup-like fluid upon it, inclining the plate gently from side to side, so that it may spread evenly over the surface, and let the superfluous fluid drain back from the right-hand upper corner into the bottle. We keep the plate rocking from side to side, so as to prevent the fluid running in lines, as it has a tendency to do. The neglect of this precaution is evident in some otherwise excellent photographs; we notice it, for instance, in Frith's Abon Simbel, No. 1, the magnificent rock-temple façade. In less than a minute the syrupy fluid has dried, and appears like a film of transparent varnish on the glass plate. We now place it on a flat double hook of gutta-percha, and lower it gently into the nitrate of silver bath. As it must remain there three or four minutes, we will pass away the time in explaining what has been already done.

The syrupy fluid was *iodized collodion*. This is made by dissolving gun-cotton in ether with alcohol, and adding some iodide of ammonium. When a thin layer of this fluid is poured on the glass plate, the ether and alcohol evaporate very speedily, and leave a closely adherent film of organic matter, derived from the cotton, and containing the iodide of ammonium. We have plunged this into the bath, which contains chiefly nitrate of silver, but also some iodide of silver,—knowing that a decomposition will take place, in consequence of which the iodide of ammonium will become changed to the iodide of silver, which will now fill the pores of the col-

* *Journal de Pharmacie et de Chimie.*

† Continued from page 346.

collodion film. The iodide of silver is eminently sensitive to light. The use of the collodion is to furnish a delicate, homogeneous, adhesive, colourless layer, in which the iodide may be deposited. Its organic nature may favour the action of light upon the iodide of silver.

While we have been talking and waiting, the process just described has been going on, and we are now ready to take the glass plate out of the nitrate of silver bath. It is wholly changed in aspect. The film has become in appearance like a boiled white of egg, so that the glass produces rather the effect of porcelain, as we look at it. Open no door now! Let in no glimpse of day, or the charm is broken in an instant! No Sultana was ever veiled from the light of heaven as this milky tablet we hold must be. But we must carry it to the camera which stands waiting for it in the blaze of high noon. To do this we first carefully place it in this narrow case, called a *shield*, where it lies safe in utter darkness. We now carry it to the camera, and having removed the ground glass on which the camera-picture had been brought to an exact focus, we drop the shield containing the sensitive plate into the groove the glass occupied. Then we pull out a slide, as the blanket is taken from a horse before he starts. There is nothing now but to remove the brass cap from the lens. That is giving the word Go! It is a tremulous moment for the beginner.

As we lift the brass cap, we begin to count seconds,—by a watch, if we are naturally unrhythmic,—by the pulsations in our souls, if we have an intellectual pendulum and escapement. Most persons can keep tolerably even time with a second-hand while it is traversing its circle. The light is pretty good at this time, and we count only as far as thirty, when we cover the lens again with the cap. Then we replace the slide in the shield, draw this out of the camera, and carry it back into the shadowy realm, where Cocytus flows in black nitrate of silver, and Acheron stagnates in the pool of hyposulphite, and invisible ghosts, trooping down from the world of day, cross a Styx of dissolved sulphate of iron, and appear before the Rhadamanthus of that lurid Hades.

Such a ghost we hold imprisoned in the shield we have just brought from the camera. We open it and find our milky-surfaced glass plate looking exactly as it did when we placed it in the shield. No eye, no microscope, can detect a trace of change in the white film that is spread over it. And yet there is a potential image in it,—a latent soul, which will presently appear before its judge. This is the Stygian stream,—this solution of proto-sulphate of iron, with which we will presently flood the white surface.

We pour on the solution. There is no change at first; the fluid flows over the whole surface as harmless and as useless as if it were water. What if there were no picture there? Stop! what is that change of colour beginning at this edge, and spreading as a blush spreads over a girl's cheek? It is a border, like that round the picture, and then dawns the outline of a head, and now the eyes come out from the blank as stars from the empty sky, and the lineaments define themselves, plainly enough, yet in a strange aspect—for where there was light in the picture we have shadow, and where there was shadow we have light. But while we look it seems to fade again, as if it would disappear. Have no fear of that; it is only deepening its shadows. Now we place it under the running water which we have always at hand. We hold it up before the dull-red gas-light, and then we see that every line of the original and the artist's name are reproduced as sharply as if the fairies had engraved them for us. The picture is perfect of its kind, only it seems to want a little more force. That we can easily get by the simple process called "intensifying," or "redeveloping." We mix a solution of nitrate of silver and of pyrogalllic acid in about equal quantities, and pour it upon the pictured film and back again into the vessel, repeating this with the same portion of fluid several times. Presently the fluid goes brownish, and at the same time the whole picture gains the depth of shadow in its darker parts which we desire. Again we place it under the running water. When it is well washed, we plunge it into this bath of hyposulphite of soda, which removes all the iodide of silver, leaving only the dark metal impregnating the film. After it has remained there a few minutes, we take it out and wash it again as before under the running stream of water. Then we dry it, and when it is dry, pour varnish over it, dry that, and it is done. This is a *negative*,—not a true picture, but a reversed picture, which puts darkness for light, and light for darkness. From this we can take true pictures, or *positives*.

Let us now proceed to take one of these pictures. In a small room, lighted by a few rays which filter through a yellow curtain, a youth has been employed all the morning in developing the sensitive conscience of certain sheets of paper, which came to him from the manufacturer already glazed by having been floated upon the white of eggs, and carefully dried, as previously described. This "albumenized" paper the youth lays gently and skilfully upon the surface of a solution of nitrate of silver. When it has floated there a few minutes, he lifts it, lets it drain, and hangs it by one corner to dry. This "sensitized" paper is served fresh every morning, as it loses its delicacy by keeping.

We take a piece of this paper, of the proper size, and lay it on the varnished, or pictured side, of the negative, which is itself laid in a wooden frame, like a picture-frame. Then we place a thick piece of cloth on the paper. Then we lay a hinged wooden back on the cloth, and by means of two brass springs, press all close together.—the wooden back against the cloth, the cloth against the paper, the paper against the negative. We turn the frame over and see that the plain side of the glass negative is clean. And now we step out upon the roof of the house into the bright sunshine, and lay the frame, with the glass uppermost, in the full blaze of light. For a very little while we can see the paper darkening through the negative, but presently it clouds so much that its further changes cannot be recognized. When we think it has darkened nearly enough, we turn it over, open a part of the hinged back, turn down first a portion of the thick cloth, and then enough of the paper to see something of the forming picture. If not printed dark enough as yet, we turn back to their places successively the picture, the cloth, the opened part of the frame, and lay it again in the sun. It is just like cooking; the sun is the fire, and the picture is the cake; when it is browned exactly to the right point, we take it off the fire. A photograph printer will have fifty or more pictures printing at once, and he keeps going up and down the line, opening the frames to look and see how they are getting on. As fast as they are done, he turns them over, back to the sun, and the cooking process stops at once.

The pictures which have just been printed in the sunshine are of a peculiar purple tint, and still sensitive to the light, which will first "flatten them out," and finally darken the whole paper, if they are exposed to it before the series of processes which "fixes" and "tones" them. They are kept shady, therefore, until a batch is ready to go down to the toning room.

When they reach that part of the establishment, the first thing that is done with them is to throw them face down upon the surface of a salt bath. Their purple changes at once to a dull red. They are then washed in clean water for a few minutes, and after that laid, face up, in a solution of chloride of gold, with a salt of soda. Here they must lie for some minutes at least; for the change, which we can watch by the scanty daylight admitted, goes on slowly. Gradually they turn to a darker shade; the reddish tint becomes lilac, purple, brown, of somewhat different tints in different cases. When the process seems to have gone far enough, the picture is thrown into a bath containing hyposulphite of soda, which dissolves the superfluous, unstable compounds, and rapidly clears up the lighter portions of the picture. On being removed from this, it is thoroughly washed, dried, and mounted, by pasting it with starch, or dextrine, to a card of the proper size.

The reader who has followed the details of the process may like to know what are the common difficulties the beginner meets with.

The first is in coating the glass with collodion. It takes some practice to learn to do this neatly and uniformly.

The second is in timing the immersion in the nitrate of silver bath. This is easily overcome; the glass may be examined by the feeble lamp-light, at the end of two or three minutes, and if the surface looks streaky, replunged in the bath for a minute or two more, or until the surface looks smooth.

The third is in getting an exact focus in the camera, which wants good eyes, or strong glasses for poor ones.

The fourth is in timing the exposure. This is the most delicate of all the processes. Experience alone can teach the time required with different objects in different lights. Here are four card-portraits from a negative taken from one of Barry's crayon pictures, illustrating an experiment which will prove very useful to the beginner. The negative of No. 1 was exposed only two seconds. The young lady's face is very dusky on a very dusky ground. The lights have hardly come

out at all. No. 2 was exposed five seconds. Undertimed, but much cleared up. No. 3 was exposed fifteen seconds, about the proper time. It is the best of the series, but the negative ought to have been intensified. It looks as if Miss E. V. had washed her face since the five-seconds picture was taken. No. 4 was exposed sixty seconds, that is to say, three or four times too long. It has a curious resemblance to No. 1, but is less dusky. The contrasts of light and shade which gave life to No. 3, have disappeared, and the face looks as if a second application of soap would improve it. A few trials of this kind will teach the eye to recognize the appearances of under and over exposure, so that, if the first negative proves to have been too long or too short a time in the camera, the proper period of exposure for the next may be pretty easily determined.

The printing from the negative is less difficult, because we can examine the picture as often as we choose; but it may be well to undertime and overtime some pictures, for the sake of a lesson like that taught by the series of pictures from the four negatives.

The only other point likely to prove difficult is the toning in the gold bath. As the picture can be watched, however, a very little practice will enable us to recognize the shade which indicates that this part of the process is finished.

(To be continued.)

Proceedings of Societies.

AMATEUR PHOTOGRAPHIC ASSOCIATION.

A COUNCIL meeting of the Amateur Photographic Association was held, July 6, at 12, York Place, Portman Square, the Right Honourable the EARL of CAITHNESS, Vice President in the chair. The minutes of the last meeting having been read and confirmed, the following members and subscribers were proposed and elected:—

Lady Foley; Lt.-Col. Biggs; Mrs. Brownlow; John Taylor, Esq.; J. C. Arkwright; John Lloyd, Esq.; Miss L. E. Ramsden; R. W. Morris, Esq.; Mrs. M. S. Harrison; — Gale, Esq.; W. Saville, Esq.; John Douglas, Esq.; The Honourable W. Carrington; T. Brownrigg, Esq.; W. R. Cherrill, Esq.; R. L. McMorland, Esq.; Dr. T. M. Lowndes; E. Coward, Esq.; Mrs. C. Browne; T. Herney, Esq.; Captain Poulton; A. Armour, Esq.; George Barr, Esq.; Robert Verschoyle, Esq.

The Secretary laid before the meeting the statement which he had been directed to prepare, relative to the subscriptions, by which it appeared they were greatly in arrear. The secretary was therefore instructed to send a circular to the members and subscribers, to impress upon them the importance of paying their subscriptions when due; viz., the 1st June each year; and after some discussion it was proposed by his Grace the Archbishop of York, seconded by the Viscount Ranelagh, and decided by the meeting, that henceforth no person elected shall be considered a member of the association until the first subscription be paid, which must be within three months of notification of such election; and that any member whose subscription remains unpaid for one month, after a second notice from the secretary, shall be considered as having withdrawn from the society.

The secretary then laid before the meeting between two and three thousand pictures, being the contributions of members of the present year, comprising every variety of subjects and views in almost every part of the globe.

Mr. Glaisher then read a statement of the numbers, sizes, and relative excellence of this year's pictures, as determined in conjunction with Mr. Shadbolt, of which the following is a condensed abstract:—Pictures of the highest class (Class 1) thirty, contributed by the following members:—By Major F. Gresley, 6; by W. D. Chidson, 4; by W. Chureh, jun., 3; by A. Henderson, 3; by Lt.-Col. Biggs, 2; by T. W. Rimington, 2; and one each by the Honourable W. W. Vernon; Lt.-Col. the Honourable D. F. do Ross; J. A. Rolls; H. St. V. Ames; Lt. E. C. Impey; Major Innes; F. Beasley; Baynham Jones; Miss E. Scott; and E. R. Hall.

Class 2 comprises 82 pictures, contributed by 38 members, amongst whom Lt. Impey stands first, having no less than 16; A. Henderson, 8; Thomas Pryce, 4; F. E. Currey, 3; the Honourable W. W. Vernon, 3; Dr. Hallifax, 3; and Col. Biggs, 3.

Class 3 comprises one hundred and seventy-six pictures, contributed by sixty-two members. Here again Lt. Impey stands

first, having 22; T. W. Rimington, 18; A. Henderson, 12; Col. Biggs, 9; Captain Hutton, 7; T. Pryce, 6; W. C. Moens, 5; J. Bevington, 5; and the Honourable and Reverend A. Campbell, 2.

Class 4 comprises two hundred and twenty pictures, amongst which are many which are excellent, by most of the members already mentioned, and W. D. Hemphill, M.D., Mrs. C. S. Harris, J. A. C. Brauffill, H. Clayton, T. Ebbage, Captain Playfair, W. Hartford, Vero Taylor, Lieutenant-Colonel Holden, O. J. Jones, H. B. Bowman, G. S. Penny, J. H. Ravenshaw, R. Murray, F. J. Oliver, D. W. Hill, T. Martin, Lt. Noverre, T. Smith, T. Fenn, J. A. Melany, Major Burt, Sir M. Cave, Bart.; Rev. F. Gutierrez, D. Hornby, R. le Gricce, C. Crosthwaite, A. Suzanne, Major Houghton, Lady Matheson, Captain Davies, the Viscountess Jocelyn, F. R. Barclay, J. C. Arkwright, Major Russell, and some very interesting photographs of the moon by P. J. Kaiser, of Leyden Observatory. There is also a life-like portrait of the Prince of Wales, by the Earl of Caithness.

Class 5 comprises the remainder of the pictures, mostly good, many very good, and worthy of special notice, did space permit.

The following prizes were awarded:—

1st Prizes.—Baynham Jones, Esq., for a 10 × 8 picture, "A Misty Morning;" and Major Gresley for a pair of 10 × 8 pictures, "Sunshine" and "Shade."

2nd prize.—To W. D. Chidson, Esq., for a pair of 8 × 6 pictures, "Going a Milking," and "Been a Milking."

3rd prize.—To A. Henderson, Esq., for a 9 × 7 picture, "The Mountain Maid," (Canadian steamboat; instantaneous.)

4th prizes.—To Lt. E. C. Impey, for a 12 × 10 picture, "Hill and Tank," at Ulwur, Hindostan, and T. W. Kimington, for a 10 × 8 picture, "The Hall of Columns, Karnac." Total value, 27 guineas.

The council also decided that a "certificate of honourable mention" should be given to the following members: Lt. E. C. Impey, The Honourable W. W. Vernon, A. Henderson, W. Church, Jr., T. W. Rimington, J. A. Rolls, Lt. Col. Biggs, H. St. V. Ames, Major Innes, F. Beasley, E. R. Hall, Miss E. Scott, T. Pryce, F. E. Currey, Dr. Hallifax, Capt. Hutton, W. C. Moens, J. Bevington, The Honourable and Reverend A. Campbell, Major Burt, D. Hornby, R. le Gricce, P. J. Kaiser, H. Clayton, Vero Taylor, and Mrs. C. S. Harris. No prize was awarded for stereographs, as although the average quality of this class of pictures is above that of last year, yet no particular picture was considered of sufficient excellence to merit a prize. The Rev. H. B. Ingram was elected member of council, in place of John Peun, Esq.

The Secretary put the question to the meeting, whether the proposed Exhibition should be held now or not, and after some discussion it was decided that as the season is so far advanced it shall be held at the close of the year, provided the necessary funds can be raised.

A vote of thanks was passed to the Referees for the time and attention they had devoted to the affairs of the Association.

A vote of thanks was also passed to A. Glendenning, Esq.

Dr. W. D. Hemphill, and S. H. Maugham, Esq., for their great and disinterested exertions in behalf of the Association, and for the large number of members and subscribers who had joined the Society through their efforts.

The proceedings then terminated.

A. J. MELHUIS, Hon. Sec.

Correspondence.

FOREIGN SCIENCE.

[FROM OUR SPECIAL CORRESPONDENT.]

Paris, July 22nd, 1863.

M. BLANQUART EVRARD has addressed a *Mémoire* to the Imperial Society of Lille, "On the Intervention of Art in the Formation of Photographic Negatives." In a letter to the Paris Photographic Society, accompanying this Memoir, he states: "The photographic proof being inevitably the unvarying copy of the model placed opposite the objective, the artist can modify the effect and value of the picture, so that the work which leaves his hand will be his own, and as

in the other products of art, bear the stamp of his individuality."

There is, therefore, unless I deceive myself, a new road open to photography: I should add, that apart from this point of artistic view, which is the most important part of my study, there is another purely photographic, to which I ask permission to call the attention of the Society.

We know that photography is condemned to produce in one and the same *unit of time*, a combination of objects possessing extremely diverse photogenic properties. Hence arise the disparities of hue and the false effects we frequently encounter, even in the most magnificent proofs; and if in certain pictures the waves of the sea resemble black ink, and the guides upon Mont Blanc resemble chimney-sweeps, it is because it is impossible for the most skilful operators to make the objects appear with their local tones in the same space of time as luminous clouds, glaciers, or snow. This example among a thousand will suffice to make us appreciate the advantage which may be derived from the possibility of completing, by a subsequent exposure, those parts of the image where the action of the light has been insufficient during the exposure in the camera, or by the attenuation, by purely chemical means, of the lights too vividly marked during the first exposure upon the parts too strongly lighted.

Upon this communication the president, M. Regnault, remarked, that the assistance M. Blanquart Evrard's researches could render to photographers consisted in the power it gave them of modifying at will the effects of a given negative. To turn it to useful account, it would be desirable to make two negatives, so that one might be submitted unhesitatingly to every kind of experiment, and that if damaged, there would remain the other to fall back upon.

M. Poitevin, who presented the Society with some proofs obtained upon enamel by vitrification, expresses himself on this subject in the following terms:—

"I do not for a moment wish to enter upon any discussion on the various processes which have been and are now employed by other photographers to produce photographic impressions by means of vitrifiable culvers upon glass, porcelain, or enamel; although very probably the insolubilizing of light upon bichromatized organic matter is the basis of these various methods, bitumen of Judca having, I believe, been abandoned for some time past by the skilful operator, who extolled its use in 1854. You know, also, that previous to 1855 no one had employed the bichromates with organic matters to produce permanent pictures on paper or other surfaces, before the announcement I made at this period.

"The vitrified proofs upon enamel which I submit to the appreciation of the Society, have been obtained by my process on glass, prepared with per-chloride of iron and tartaric acid, which, since 1860, I employed in carbon printing. In the present instance I employ instead of carbon an enamel in impalpable powder to develop the picture. I transfer this latter, by means of a film of collodion, on to a plate of enamelled copper, or porcelain, &c., and I fix it by means of a sufficient heat, in an enameller's muffle."

M. Beyrich, of Berlin, presented to the Society some vases of glass porcelain, &c., of various forms, to which he has found the means of applying ordinary photographic proofs.

His process is based upon the discovery he has made of a paper from which the sensitive coating is easily detached; this paper, treated in the ordinary manner, resists until after it has passed through the toning baths; it is then only that it becomes easy to separate the printed picture from it as a sort of film which may be glued upon glass or porcelain vessels, whatever be their form. This application made to small ground glasses constitutes images visible by transparency analogous to lithophanes. Hitherto, M. Beyrich has only succeeded in transporting the picture in this manner to vases as a decoration, but he, at the same time, seeks the means of baking these pictures, so as to convert them into vitrified proofs. Success has not yet crowned his efforts; the gold deposited upon the silver during the toning, yields in

the muffle only a dead, light rose colour, but by modifying this first attempt M. Beyrich hopes soon to succeed in converting this proof into vitrified pictures.

WHAT A LENS WILL COVER—ANGLE OF VIEW —EQUIVALENT FOCUS.

SIR,—Being in search of a good landscape lens to use in a camera for 11 by 9 pictures, for general purposes, and also for engineering subjects, bridges, &c., where a large angle of view is required, say 60° or 65° , I ask the favour of your advice as to the *form* of lens best adapted for such purpose. It is not a question of maker, as I am satisfied there is little to choose between three or four of our best manufacturers; but, as to what a lens will cover, I am thoroughly convinced (apart from the evidence published in a contemporary, respecting a picture of Whippingham Church, by Mr. Ernest Edwards), that the triplet form does cover a very wide field. I made the experiment a few days since of taking a view 11 by 9, with the No. 1 triplet of 7 inches back focus, and another the same size from the same point, with a caloscopic of $11\frac{1}{2}$ in. back focus. The triple gave a larger circle of light, and better defined to the edges than the caloscopic; the latter seemed to soften down the outer edge of the circle, like a vignette, a much greater distance into the field, while the triple worked much closer to the outer line, and then finished off more abruptly, or with a sharper edge. Of course, the image formed with the $11\frac{1}{2}$ in. focus lens, was larger than the other, and, consequently, the angle of view, smaller.

I next turned my attention to some pictures sent me by a friend who swears by the "aplanatic" form, they were very good but accompanied with a note "taken with the aplanatic lens, 9 in. focus, including an angle of nearly 70° ," although the base line of the picture only measured $8\frac{1}{2}$ inches. This is an error committed, I am afraid, too frequently, in stating the angle included by various lenses; it is a subject that I much wish some of your numerous contributors would take up, and treat in a popular manner with diagrams, &c., for, according to my calculation, the pictures in question would only include an angle of a trifle less than 50° . This is, perhaps, as much as most photographers care for, and certainly is a wonderful improvement on the old form, which only includes about 38° ; yet in stating the angle comprised in a given picture, and by a certain lens, it ought to be done correctly, or others are likely to be misled by it.

I am going on the supposition that in speaking of the angle of view it is measured on the horizontal or base line of the picture, and not diagonally. I find that to include an angle of 60° on a plate 11 by 9, I shall require a lens of about $9\frac{1}{16}$ in. focus. Now, in searching the lists of our best makers, I find no such focus quoted; there is a triplet of 10 in. back focus. I wish all could be induced to state the true focal length, we then should not be bothered with such remarks as *nominal* and *real* focus, which are very perplexing. Now if the back focus is 10 in., the real focus will probably be 1 in. or $1\frac{1}{2}$ in., more. This brings me to the next nearest advertised lens, the aplanatic of 12 in. focus. Now, either of these for a picture, 11 by 9, will not include in round numbers more than 50° ; there is, then, nothing left to fall back upon but the aplanatic of 9 in. focal length; this would give the required angle, but whether it would work satisfactorily in other respects I am wishful to know, and also if at the same time you could inform me the equivalent focus of the No. 2 triplet of 10 inches back focus. While writing the foregoing I have received the *Notes* for the 15th inst., in which Mr. Sutton speaks favourably of a triplet lens of 14.6 focus for 12 by 10 pictures; now this, according to my previous mode of calculation, only gives an angle of 45° . Should I be in error, doubtless you will put me right.

TANNO-GLYCERINE.

[We do not know of any lens at present catalogued which will give you an angle of 60° or 65° on 11 by 9 plates. The only form of lens which will give the required angle

satisfactorily is the triple, and the focus of No. 1 is too short, and that of No. 2 too long to give the angle required on 11 by 9 plates. The No. 2 triple has an equivalent focus of a fraction over 11 inches, and would give you on 11 by 9 plates an angle of 52° , or a trifle more. This is the nearest to your requirements of any existing lens which we know. If you especially require the results to which you refer, we have no doubt that Mr. Dallmeyer would make a special lens for you of the desired focus. The aplatic would not, as you have seen, give the angle, and the distortion for engineering subjects would be intolerable.

It is a very difficult thing to popularize the subject to which you refer. When the equivalent focus of the lens is known, it is very easy to any one familiar with mathematics to ascertain the angle included in a given picture. As we stated a few weeks ago, those who have access to a table of tangents may easily make the calculation by measuring the angle formed by the equivalent focus and the base line of the picture, the amount of subject included is twice the tangent of half that angle, as we have before stated. Perhaps the simplest popular method would be to proceed as follows: ascertain the equivalent focus of the lens, either from the optician, or by direct experiment, as we have described on a former occasion. Then measure the horizontal line of the picture; upon this line let fall a perpendicular the length of the equivalent focus. Now, with a protractor measure the resulting angle, which will give, with sufficient accuracy, the amount of subject included. Your calculations as to the angle included by the respective lenses referred to in your letter are correct. The origin of the method of stating the foci of lenses as measured from the back glass originated in the importance of giving some idea as to kind of camera required, and the space necessary between the lens and ground glass. It is a great pity, however, that the equivalent focus is not also stated. The practice is, however, becoming more general.—Ed.]

THE LIME TONING BATH AND ITS DIFFICULTIES.

DEAR SIR,—I am an unfortunate man; a skeleton hangs in my photographic cupboard, and his name—no bad nomenclature considering his chemical composition—is *lime*. I am an old practitioner and printer, and for years met with such success by the old process of printing that it was with difficulty I could bring myself to adopt the new. No doubt I am looked upon as an old-fashioned fellow with out-of-date ideas when I say that I am prepared to produce from any given good negative a better print in point of tone, depth, and *modelling* than can be got from it by any of the new processes. However, in deference to the spirit of the age, I adopted the new systems, and consoled myself for any deficiency I found with the idea that the prints might possibly be more permanent. I found no difficulty in getting as good effects as other people with the acetate, the carbonate, and the phosphate; in fact I went on conquering, and, as I thought, to conquer; but at last came my check—my Waterloo—and the destroying enemy is the oil-shop product I have named above. Seduced by the hope of getting those “rich blacks” with “warm flesh tints,” I began with Ommeganck, then I carefully tried those formulæ given in the News as the “Experiments at Ryde,” with your own modification. Last of all I have tried Parkinson’s, as given in your last number, but the result in all is the same. The difficulty begins at once, I may truly say, meets me in lime-ine, for no sooner are the prints immersed than free chlorine attacks them and the bleaching process begins. Whether I make the bath with hot or cold water, or add the lime when the solution is milk-warm, according to one of your correspondents, or try it within an hour or a week, (your own modification I tried each day successively for ten days), the result is always the same: of course you know the exact effect, and I need not describe it. Shakespeare in his prescience must have caught a glimpse of “printing difficulties,” for who could better describe a “mealy print”?

“And a most instant tetter, bak’d about
Most vile and lazar-like, with loathsome crust,
My wholesome body.”

I may mention, that in addition to every conceivable precaution, I have more than once “changed my oil-shop,” but all samples of the devouring fiend seem alike. What can I do? like the ancient waggoner stuck in the mud, I invoke the gods—the deities of the photographic press, and make my first appeal to you as the Jupiter Tone-ans of that august body. Will you simply state in your column of answers if I was wrong in anything, except the quality of the lime. In my working out Parkinson’s formula, I saturated a small bottle full of water, with chloride of lime, shaking it well for some minutes, this I filtered and saturated it with whiting, and filtered that compound. Of this I took the exact quantity (rather more than $1\frac{1}{2}$ drachms), and added 35 ounces of water with 2 grains of gold—after 24 hours, I tried it, and again in 48 hours, but in both cases the same and the old failure—bleaching and meanness.

Meal, meal, meal,
On every print immersed,
Meal, meal, meal,
The last as well as the first.
It’s O! for the process old
That gave me such beautiful tints,
The honest compound of hypo and gold,
That never spoiled my prints.
Meal, meal, meal,
By Ommeganck, Parkinson, Hughes.
Meal, meal, meal,
By every receipt in the News.
An anomaly strange will appear,
If things in this fashion keep,
I shall find that bread is exceedingly dear,
While meal is so very cheap.
Meal, meal, meal,
If I float ten minutes or more,
Meal, meal, meal,
If I only float for four.
Both kinds of Saxe and Rice,
Both kinds of Rice and Saxe,
Oh, grant, kind Heaven, a short reprieve
From its venomous, deadly attacks.

—I am, dear sir, yours truly,

CHA-MEAL-ION.

[We are quite familiar with the difficulties our correspondent describes so pathetically. They proceed from excess of free chlorine, which, having such an affinity for silver, and finding it in a finely subdivided state in the print, the most convenient forum for its action, at one attacks it, and turns it into white chloride of silver, producing the lazar-like tetter of meanness. The remedy is to lessen the proportion of chloride of lime, and with a given sample of paper, gold, and lime, arrive by experiment at the proper proportion. Each of these articles vary in exact quality, and hence the variety of result when a constant formula is adhered to. Success is certain if the right method be followed. We have succeeded by pursuing the method we have described, others have succeeded by the respective formulæ for which they stand sponsors. Experiment is troublesome, it may be said. Very good: then there are other methods, giving good, but not quite the same results, which are less troublesome. Our correspondent may try a lime bath with which we have seen no failure by obtaining a bottle of Sutton’s calcio-chloride of gold, and diluting it considerably more than is recommended in the directions for use. The old hypo and gold bath gave less trouble, but rarely such pure whites or rich tones as the alkaline bath, and never better than the best results of the latter, with all the greater risk of becoming yellow. If our correspondent will send us a directed envelope, we will forward him a lime-toned print, in which there is no meanness, but a rich black tone.—Ed].

Photographic Notes and Queries.

OLD IRON DEVELOPER v. NEW.

DEAR SIR,—I have with many of your readers been much troubled with fogged and dirty negatives during the last two or three weeks.

This has been the more annoying, as, putting faith in the

bright sunshine, I had made many appointments with friends who wished to be "taken," most of whom have been grievously disappointed; but this was not the case with all, for I accidentally discovered that a stale developer gave brilliant results, while a newly mixed one produced faint and stained negatives which were, moreover, most difficult to intensify.

On the first occasion when this came under my notice, I had by me about half an ounce of an old developing mixture of sulphate of iron and ammonia, from 10 to 30 grains to the ounce, but the strength was unknown, the mixture being, in fact, residues of old developers, and which I had before used with good results. In the midst then of my troubles, one morning, when baths, new and old, neutral and acid, and newly mixed developers of every kind (iron), gave nothing but these unsatisfactory negatives, I turned to my old developer, and at once the negative came out clear and red. This I tried two or three times and with the same satisfactory results, as long, in fact, as this precious mixture lasted; after that, all was dull and dirty. I racked my memory to recall the exact composition of this, but in vain. About four days afterwards, I again experienced this peculiarity in a developer, which had nothing that I knew to recommend it, except that it had been mixed four or five days, being, in fact, one that had failed on the previous occasions.

It then occurred to me, that its merit might be due to its age, and, acting on this notion, I have since used developers which have been mixed four or five days, with the best effect.

A sulphate of iron developer which had been made about ten days, I also found to give clear negatives, though showing signs of decomposition when poured on the plate.

The effect above stated was so strikingly suggestive of the advantage under some circumstances of stale developers that I have communicated it to you: and the fact also raises two questions—whether during the last few days the light was at fault, or whether the great heat we have experienced has not affected the developer or the neutral action of the developer and the bath. To me it appears certain that in the negatives I took during the period referred to, the invisible image was on the plate in a fit state to emerge as a clean and brilliant negative, if I had had a proper developer to bring it out; such in fact as the developer I at first accidentally applied, or as the developer I afterwards designedly used a few days old, with the same good effect.—Yours truly,

M. A.

May I ask for an answer to the following photographic queries.

Tannin.

1. Is a bath acidified with nitric acid as good for the tannin process as with acetic? If not, why not?
2. Is an exposure of two minutes with Dallmeyer's triplet, full aperture, i.e., largest diaphragm, long, moderate, or short?
3. Is honey always an accelerator? is it not liable to stain the negative? is not plain tannin the easiest to work? M. A.

[It is well known to experienced operators that an iron developing solution works much better after it has been mixed a few days than when new; the presence of a per-salt having a similar influence to that of an acid in the production of clean shadows. Professional positive portraitists frequently used to mix a Winchester of strong solution months before it was required, and then dilute for use. For negatives we always prefer to have a stock mixed ready for use, especially in hot weather. There is, however, in addition to this a difference in certain samples of the sulphate of iron. A professional portraitist of great experience recently informed us that he was much troubled with thin, fogged negatives for some weeks; the trouble disappeared at once on using a new sample of iron. There is something more to be learned on this subject; but it is certain that an old brown iron solution is a great aid to clean shadows, although it lacks energy in developing at times. When it is not at hand the plentiful use of acetic is the best remedy for the difficulties which troubled you.

In answer to your other queries we may state that as a rule nitric acid is not desirable in a bath for dry plates, from the fact that organic matter is generally used in the preservative, which is apt to be decomposed by nitric acid. For this reason the organic acid is better in such cases. 2. An exposure of two minutes is excessively long for a wet plate and good light with the full aperture of the lens you name. One-fourth of that time or less would generally be long enough. We recently saw some fine negatives of portrait groups with foliage background, by

Col. Stuart Wortley, taken with the full aperture of No. 1 and 2 triple, by Dallmeyer; some of them had received instantaneous exposures, and none more than a few seconds. 3. We believe honey always to accelerate tannin plates; but in some hands simple tannin gives less trouble. See an article by Mr. Fassitt in the present number.—Ed.]

FOGGING NITRATE BATHS.

SIR,—One of your correspondents of last week, J. Bonny, seems to be in the bath fog, where I have often been in days gone by. I have found in my experience, that by making it alkaline with oxide of silver, and sunning it three or four hours, filter well, and drop in a little dilute nitric acid, put to sleep in a dark corner three or four days, I have always found it to work well. It is this resting that is required. If you work it close upon your experiments it will generally fog. If this plan won't cure it, something else is at fault.

I wish some of your correspondents would help me out of Sutton's rapid dry plate fog. I have lately been experimenting on his process, wishing to get a more certain rapid dry process. I cannot succeed yet. I shall try a few more experiments. If I cannot succeed I must go back to the old toning process. I have worked Sutton's gum arabic process, in every form, to a nicety, and have used all his remedies, spoken of in his works, to no purpose. Can you set me right?—I am, Sir, yours respectfully,

JAMES DATE.

Watchet, July 13, 1863.

Talk in the Studio.

DOUBLE SULPHATE DEVELOPER.—A correspondent says:—I have just succeeded in taking some excellent negatives with the developer given in your last by Messrs. Beckett and Willis, and find it quite equal to what they say of it. It also admits great latitude of exposure and will also bear nearly double the exposure actually necessary, which is less than half that required with ordinary iron developer.

THE ATHENÆUM ON PHOTOGRAPHY.—As a critical journal the *Athenæum* has earned the character of being always severe and seldom just; and where photography is concerned, it is often shallowly unappreciative, and for some reason or other, spiteful. We have before had occasion to call attention to scolding paragraphs relating to photography and photographers, and we have before expressed a conviction that, as the gentleman presiding over its pages has opportunities of knowing better, these paragraphs creep in during his absence on summer tours, and are the offspring of incapable and disappointed painters, whose occupation with the palette and pencil is, thanks to photography, quite gone. An amusing specimen of scolding, and of ignorant self-sufficiency recently appeared in its pages, in a notice of "Adjutor," a collection of photographic studies. We had smiled at the paragraph, but did not intend to notice it. We find, however, in our esteemed contemporary, the *Society's Journal*, a few such trenchant comments upon the remarks in question that we cannot refrain from quoting them:—"There are certain writers who, in noticing what is called Compositive Photography, are affected in the same manner that an infuriated bull is on the sight of a red rag; and there is much of the same indiscriminating, unreasoning fury shown in the paragraph on which we are commenting. There is, too, a Dogberry-like tone of scolding, and a priggish dogmatism, which is generally to be found in shallow critics, who make up what is wanting in genuine knowledge by a vehement and extravagant self-assertion. As an instance of this, note the confident, not to say impertinent, tone of this passage:—"Once for all, the "Profession" may take our word that, unless composed with the most subtle art (art of which photography has, as yet, not the dimmest idea), its compositions are, to painters, abominable." Now, whose word is it that we are to take? Probably, some one as ignorant as he is obscure. These anonymous Browns and Joneses, who are allowed to display the capacity of the art-slang vocabulary, and who so cleverly juggle words—not ideas—with a bewildering kaleidoscopic effect, and run as many changes of cant terms as a set of bellringers, assume to themselves an authority, an *ipse dixit* tone, which, to say the least, is simply funny. The patronage of these writers is not less amusing than their wilful, or perhaps more probably still, their absolute, ignorance. This writer says, "As pleasant memoranda of things seen and enjoyed, as suggestions of the unseen

substantialities of art (for we doubt if any one feels awed by a photograph of the pyramids), *photographs are handy.* On reading this, one might almost fancy that the writer of this was one of those miserable brainless daubers whose artistic existence had been happily snuffed out by photography. We really do think that journals professing to hold such high positions as the arbiters of art ought really to be a little more discriminating and catholic in their judgments."

PRESERVATIVE PROCESS.—A correspondent says: "I recently tried Mr. Blanchard's *honey preservative*; so far the results are very satisfactory. I gave 15 seconds exposure with Mr. Dallmeyer's No. 4 triple and a 12 by 10 plate. As Mr. Blanchard remarks, there is a faint blue tint in the sky. The foliage is clear and decidedly rich and full. In my mind more picturesque than in the ordinary wet process. I prepared the plates at 2 and used them at 4½ p.m., a very hot summer day last week."

PHOTOGRAPHY IN THE WITNESS BOX.—In the recent trial arising out of the Roupell forgeries, photography appears to have been frequently used in obtaining *fac-similes* of deeds, signatures, &c. A photographed copy of a deed placed in the hands of a witness under cross-examination was, however, disallowed by the judge as irregular.

MR. POUNCEY'S NEW CARBON PROCESS.—We received a day or two ago from Mr. Pouncey a slip of paper covered all over with printer's ink, and resembling in appearance the transfer paper used in manifold writers. We were informed that it was exposed on the 9th of May last, and were instructed how to develop it. Following the instructions, we immersed the paper in turpentine, and in a few minutes had the satisfaction of seeing a well-defined picture appear, with fine gradation of half tone, and clean lights. We shall have more to say on this subject shortly; but, in the mean time, may remark that so far as we can judge, the process is as simple and satisfactory as it is ingenious.

To Correspondents.

M. P.—As your first print from your first negative, the picture we have received is not had. It is not focussed with sufficient care to secure sharpness: always focus upon the eye. There is no simple method of ascertaining whether collodion is simply iodized or bromo-iodized. Experienced photographers would generally ascertain by the resulting negative. 2. There are many good bromo-iodized collodions in the market, but we cannot speak with certainty as to whether they are all equally suitable for dry plates, as well as wet. Blanchard's collodion is one which we have found answer well for both purposes; as will, doubtless, several others which you will find announced in our advertising pages. Most bromo-iodized collodions will keep a few months, and some longer. 3. We do not know anything of the collodion of the firm to which you refer, nor can we account, without seeing an example, for the odd defect you describe. 4. We know nothing especial of the keeping qualities of No. 1. 5. Most bromo-iodized collodions will answer for positives, as well as negatives. 6. Good positives may be obtained in a negative bath; but, as a rule, more nitric acid is desirable for the positive bath than for the negative bath.

C. W. WALTER.—Take a little emery powder and water, and place on the glass you wish to roughen; then place another plate of glass upon it, and grind the two together until you get the surface required. The rough surface will, of course, slightly interfere with the transparency of the glass, the amount of opacity depending on the coarseness or fineness of the roughed surface.

CALX.—Your negative arrived shivered to some hundreds of pieces, not one large enough to enable us to come to any conclusion upon its character. We are at a loss to suggest a cause for the stains, the nature of which we do not clearly understand. Have you tried another sample of collodion? Does it proceed from over-iodizing?

J. FULLER.—The whites in the print sent are quite as pure as they should be. There ought not to be more than a few minute points of pure white in a picture; a slight amount of detail should be found in white fabrics, like the cap strings in your picture. More pure white would injure the picture.

CONSTANT READER AND AMATEUR.—Try the lime toning bath given in our last. It yields fine black tones.

GEORGE CHIPMAN.—The yellow spot is a hypo stain, caused by hyposulphite of soda, probably on the fingers, touching the print before it was fixed. 2. The silver in old hypo solutions should be precipitated as a sulphide, by means of liver of sulphur, as we have repeatedly described.

A.—The deposit in the shadows which makes the film rise in small blisters when varnished, is generally the result of dirty plates. The tendency will be increased by the use of some samples of collodion; a thin rotten film will aid in producing the defect. The silver in developing solutions will gradually be precipitated in time as a grey metallic powder. Any traces remaining in the supernatant fluid may be precipitated with coumion salt as a chloride.

AN AMATEUR asks will a "carte" lens cover as much as a half-plate lens. That entirely depends upon its length of focus. Some card lenses have a long focus and will cover a half-plate, whilst others have a shorter focus and will not cover more than a quarter-plate. Lenses advertised as card

lenses are generally intended to define a standing figure three inches high, and cover the whole card, and it does not follow that they will cover much more. They are of course suitable for other work as well. The formula of the "Alabastrine Solution" is a trade secret, which we are not at liberty to divulge. Its distinctive characteristic was that it gave white pictures without the disagreeable blue tint. It was sold by Squire and Co.; but since the introduction of card pictures has not been much used, we believe.

PLATO.—The prints appear to have been fixed in an old and acid hypo bath. 2. The exact quantity of hypo required to fix a given number of prints cannot with accuracy be stated; but you will be safe if you use about 2 ounces of hypo in 10 ounces of water for 100 card prints. 3. 25 card prints are not too many prints to tone at once in 10 ounces of water containing 1½ grains of gold, &c., provided they were kept moving, and had constant attention. They would probably tone within a quarter of an hour.

AN AMATEUR SUBSCRIBER.—You used the bath of gold and carbonate of soda too soon after it was mixed; and the negative is not sufficiently vigorous to give good tones. 2. Possibly your bath contained acetic acid, in which case neutralising with carbonate of soda would produce acetate of silver in the bath, which is a frequent source of pin-holes. Sun the bath and filter; then try.

A LOVER OF THE BLACK ART.—We have seen, and ourselves produced, some very good pictures on Dr. Hill Norris' dry plates. But they require great care in keeping and in developing. 2. We cannot say anything about exposure necessary without knowing the subject, state of light, stop to be used, &c. Dallmeyer's compound stereoscopic lens will produce as good portraits as his No. 1 or 2 B, but of course of smaller size. It is, as you anticipate, one of the most rapid lenses made. It is not so well suited for enlarging and copying as the triple.

J. GIBERT.—The formation of metallic silver on the plate during development may be due to various causes, such as the presence of organic matter in the bath, want of sufficient acid in the developer, high temperature, &c.

PERPLEXITY.—We have several times recently had complaints of similar spots; but we have no clue whatever as to the cause. The spots which, in the unfixed print enclosed, showed most at the back, have, after we have toned and fixed it, almost entirely disappeared at the back, and are seen chiefly in looking through the prints. It is most probable that they are produced by something in the paper before it is albumenized, but by what we cannot say. We should like to try a sheet of the paper said to be prone to produce those spots, in order to test it.

T. G.—The chief thing you could do to improve the groups would be to use a smaller stop, and arrange the figures in a curve to suit the lens. In those sent the marginal figures are sharpest; the central figures being a good deal out, whilst the sash a little distance behind the central figures is well defined. You will readily see that if the central figures had been further back, they would have been sharper.

P. G.—You entirely mistake the meaning of the term brilliancy. This is not a brilliant photograph, but a hard one, all black and white, without half-tone. In a brilliant print there is very pure black or white, mere touches, but abundance of gradation. Expose twice as long, and intensify less.

ED. REEVES.—The spot looks like hypo, and occurred most probably after the paper was sensitized. Some samples of paper are more prone to mealiness than others, but slow toning with an old solution is generally the best remedy.

G. E. T.—No especial standard has ever been agreed upon; but we think that about half an inch in the picture for each foot of height in the sitter gives a good idea of proportion. Mounting the print with very little space over head gives the effect of tallness, and with excess of space the effect of shortness.

ESQUIER.—You do not state which formulae you employed: several were given in the article referred to. If you mean the one we especially recommended, it will keep good for weeks without precipitation of the gold, and many, if the prints be properly washed, be used over and over without disadvantage. 2. The spots to which you refer are due to faults in the paper. 3. Always filter any portion of the toning bath returned to the stock bottle.

A YOUNG PHOTOGRAPHER.—We do not know of any photographic art union in existence. Several correspondents in our next.

Photographs Registered during the Past Week.

MR. JAMES MUNRO, 56, St. Peter's Place, Canterbury,
Photograph of Canterbury Cathedral.

MR. EDWARD REEVES, 159, High Street, Lewes, Sussex,
Two Photographs of Dr. Thomas Hodgkin.

MR. JOHN FREW, Railway Terrace, North Shields, Northumberland,
Three Photographs—Views in Holywell Dean.

MESSES. W. AND D. DOWNEY, 9, Eldon Square, Newcastle-on-Tyne,
Photographs of Lord Palmerston, Lady Palmerston, Lord
Lovelace, A. H. Layard, Esq., M.P., Lord C. Paget,
Professor Owen, Rt. Hon. E. Cardwell, M.P., William Rose,
Lord Mayor of London.

* * * The Publisher respectfully requests that all remittances above 3s. may be made by Post-Office Orders, payable to THOMAS PIERCE, at the Chief Office, St. Martin's-lc-Grand. Sums below 3s. may be remitted in postage stamps.

Works for Review and Communications to the Editor to be addressed to 32, PATERNOSTER ROW.

THE PHOTOGRAPHIC NEWS.



Vol. VII. No. 256.—July 31, 1863.

CONTENTS.

	PAGE		PAGE
Photographs in Printing Ink	361	Correspondence—Foreign Science—Does Light only Exist in the	
Photo-Engraving	363	Eye—Successful Lime Toning	369
The Difficulties of Lime Toning. By Jabez Hughes	364	Photographic Notes and Queries—Angle of View, &c.—Ebonite	
Photographic Chemicals	364	Baths	371
Critical Notices	365	Talk in the Studio	371
Spectra of the Stars	366	To Correspondents	372
Mr. Pouncey's New Patent Process for Permanent Printing.....	367	Photographs Registered during the past Week	372
Doings of the Sunbeam.....	368		

PHOTOGRAPHS IN PRINTING INK.

THE production of a photograph direct from the negative, in the very material which has always been regarded as the type of permanency and pictorial stability—printing ink, is unquestionably a master stroke of ingenuity. This has been the result desiderated from the time that silver prints have been found to fade. As carbon process after carbon process has been tried with more or less of success, as one method after another has been suggested for securing permanency in silver prints, it has been the repeated ejaculation, "If we could only get photographs in printers' ink, in the material which gives durability to printed books and engravings!" Mr. Pouncey has solved this problem. Whatever may have been the merits or demerits of his former processes and his former claims, we are bound to state that his present process, just protected by Her Majesty's royal letters patent, is as beautiful and simple as it is ingenious.

The term "photograph in printing ink" is at first sight suggestive of a photo-engraving or a photo-lithograph. But let the term be distinctly understood: by the process to which we refer, a print is produced direct from the negative in printing ink, just exactly as a print, by the ordinary method of printing, is produced in silver. This process does not in any way clash with photo-lithography or photo-engraving, although it may possibly be found a valuable adjunct to both, as a method of getting the image on the stone or plate. At present they are valuable for the rapid reproduction in large numbers of all subjects which can be represented in the conventional gradation of stipple or hatching. Even if half-tone be eventually satisfactorily secured in negatives of all classes, from nature, they will not be put on the stone or plate for production by the printing press, except when large numbers are required. But in Mr. Pouncey's new process he aims at superseding the use of silver for single prints, whether the subject be portrait, landscape, or reproduction.

We have, just before writing these remarks, exposed and developed, in conjunction with Mr. Pouncey, two portrait negatives, one very soft and thin, and the other very dense. The light was one of the worst we have had this summer, misty and yellow, only one degree removed from a fog. This of course interfered with the certainty of our operations, and materially prolonged the exposure. Nevertheless we obtained two good prints. The time of exposure usually required in sunlight with an ordinary good negative, Mr. Pouncey informed us, is about twenty minutes or half an hour. On this occasion we exposed for about two hours; possibly a quarter of an hour longer, in the bad light we had, might have been an advantage.

In the point of weakness, common to most carbon processes, these prints are faultless. The gradation of half-tone is amazingly perfect in every part. Every gradation in the negative appears to be accurately registered. So far as we can see at present, the colour or tone of the prints is the chief point in regard to which we should desire modification.

The material used is, as we have said, printing ink, and the colour of the print is, therefore, gradations of black. Now when these gradations are formed by stippling or hatching, giving a perfect black and perfect white in small points, or fine lines side by side, a variety of agreeable tones of pure grey are produced, varying in depth of tint according to the state of subdivision of the points or lines and spaces. But when the gradation is produced, as we have it here, by gradations of depth in continuous tints of black printing ink like a wash in water-colour painting, the greys appear to have a very slight greenish brown or olive tinge, which we scarcely like. This, it will readily be seen, is, however, a matter entirely under control, the exact colour of the ink being a matter in the hands of the operator, a warmer tint being easily obtainable. Another difficulty which has existed, Mr. Pouncey is just surmounting. We described one of these prints we received some months ago; and we then said that something more was desirable in the purity of the lights or whites. Mr. Pouncey informed us at the time that this was a matter chiefly depending on the quality of the paper. A sample of paper he has recently obtained will, he believes, entirely remedy this difficulty. One of the prints we have just tried is upon it, and shows a considerable improvement upon the former print, and will, probably, leave little to desire. Nevertheless, in points of detail, as to the exact material and tint desirable for different subjects, it is probable that enlarged experience will bring improvements.

Now as to the process. In another column we publish the specification of the patent; but it may, nevertheless, be interesting to give a brief summary of the manipulations, and the principle upon which they are based, here. It is somewhat singular that upon two of the oldest facts in photography this process is founded: upon the fact that bitumen of Judæa becomes insoluble in its ordinary solvents when exposed to the action of light—a fact known to Niepce as early as 1827, if not earlier to some of our own savans; and upon the fact that bichromates, in combination with organic matter, become insoluble under the action of light, a fact discovered by Mr. Monge Ponton, in 1838. Almost every carbon process and method of photo-lithography and photo-engraving yet propounded has been based upon one or the other of the facts we have just mentioned.

The merit of Mr. Pouncey's process consists in the novel and ingenious application of known facts, and in further development of these facts. The properties of bichromates and of bitumen of Judæa were known, but it was not known that these substances might be so incorporated, or combined, with ordinary printing ink that it should become insoluble after exposure to light. This is what he discovers. In many respects his new carbon process resembles others. He takes lamp-black or other carbonaceous pigment—a fatty matter, such as tallow and turpentine—the materials composing printing ink; to these he adds bitumen of Judæa, or bichromate of potash, or both; these materials are ground together, and thoroughly incorporated. The pro-

portions are varied with circumstances; generally, as much pigment is added as will make the mixture the consistency of cream, and as much of the bichromate as will remain in the solution, which is a very small proportion, as it is very sparingly soluble in turpentine. A suitable paper is first slightly sized with gelatine, and when dry, brushed over with the preparation of printing ink, and then dried. The paper so prepared, and kept in the dark, will remain ready for use without deterioration for an indefinite period, some months certainly.

This blackened paper, when placed under a negative and exposed to light, undergoes the change to which we have referred: the parts of the ink on which light acts become insoluble, whilst the protected parts remain, as at first, soluble in turpentine, benzole, &c.; and, what is singular, the amount of insolubility is in sufficient gradation to leave on the paper just the proportion of ink which shall register every variety of tone in the negative. And here is to be noted another valuable little point of detail in the manipulations. As we have already remarked, the weak place of most carbon processes hitherto has been the difficulty of securing half-tone. This was largely overcome by M. Fargier's modification. He rightly conceived that one source of the difficulty lay in the fact, that as the action of light commenced at the surface of the layer of gelatine, bichromate, and carbon, spread on paper, it only penetrated *through* the most transparent parts of the negative constituting the deepest shades. The parts constituting the half-tone were only acted upon superficially, the part in immediate contact with the paper being unacted upon, was, therefore, readily dissolved entirely off, and the result was a print with hard black and white tones, without perfect gradation. He, therefore, coated the exposed layer of gelatine, &c., which was used on glass instead of paper, with collodion, and immersed the plate in water, which detached the film; the unaltered gelatine, &c., was then washed away from the underneath side. By this contact with the collodion every part acted upon by light was preserved, and half-tone secured. Mr. Pouncy, possibly without having noticed the coincidence, acts upon a similar principle. He uses a fine, thin wove paper, of the quality known as bank post. This is made transparent before it is coated with printing ink, and the printing is effected *through* the paper. The inked side never comes into contact with the negative, but the plain side of the paper. How far half-tone would be secured if the inked side were printed on, we cannot, with certainty, say, but we have no doubt that the method of printing through the paper, and thus securing the first action on those parts in immediate contact with the paper, must materially tend to secure half-tone. For this reason, whenever the slightest action takes place, a thin film of ink in immediate contact with the paper is rendered insoluble. All but that thin layer will be subsequently dissolved and removed, but the half-tone remains. The transparent parts of the negative permit the full action of light to penetrate the entire thickness of the layer of ink, and thus the deep shadows retain a full body of insoluble ink, and are the blackest portions. On slight reflection it will be readily seen, then, how this mode of printing through the paper conduces to the production of half-tone; and this is our explanation of the great superiority of these prints in this particular. Whether Mr. Pouncy holds the same view, or whether his practice may confirm it, we do not know, as we did not enter into theoretical considerations in our interview.

The proper exposure may be learned by experience, or by the exposure side by side with the negative of a trial piece of paper. Being black to begin with, examination affords no clue to the process of printing. When the exposure is completed, the print is immersed in a dish of turpentine, which dissolving the ink which is not acted upon, and removing it, reveals the image, consisting of the gradations of insoluble ink. After draining a few minutes, the print is removed to another dish of clean turpentine, which effec-

tually clears the lights and finishes the print. It is now laid on blotting paper, a strip of which is placed at the bottom edge to absorb drainings, and then dried in the sun. Care must be taken not to touch the face during the operations, for whilst the ink is not acted on by a solvent, it is easily smeared until it is dry. Other solvents than turpentine might be used, but turpentine appears to answer best. It may be used over and over, merely using each time a little fresh, to remove the final traces of soluble ink and secure purity. Nothing can be more interesting than to witness the completeness with which every trace of the ink leaves the whites in the most perfect purity. With turpentine there appears to be no danger of injuring the print, however long its action may be continued, not even a trace of half-tone being dissolved. But with a stronger solvent, such as benzole, for instance, great care is necessary, its prolonged action impoverishing the print. Where the operations are sufficiently extensive to make the cost of turpentine a consideration, it is probable that it might be utilized for some purposes where the ink it had collected whilst in use would not be objectionable, as, for instance, in black paint. As the price of turpentine has for some time been high, costing now, we believe, about eight shillings a gallon, this might become a matter worthy of consideration.

The lights of the cleansed prints, on the most satisfactory paper, are quite transparent, becoming white, of course, when mounted. A slight tint might easily be secured, in subjects needing it, by mounting on a tinted paper. Mr. Pouncy recommends varnishing the prints, first with a spirit varnish, and then with the usual varnish applied to maps, prints, &c. We are inclined to think that this will not be necessary, and will be in some instances objectionable. With the sample of paper we have referred to as most successful, the print may be mounted face downwards, the print showing perfectly at either side. For some experiments ordinary tracing paper has been used, which answers very well, but not so perfectly as the sample to which we have just referred.

It will be seen that, apart from the question of cost, an immense saving being effected by dispensing with silver and gold; apart from the question of permanency, the greatest question of all, there is a great saving of time in absolute manipulation. The removal of the ink is an operation about equivalent, in its demands upon time, to toning. There is then no fixing, and no interminable washing; the print is completed.

As will be seen from the specification, there are various other very important economic applications of the process. A transfer, with perfect half-tone, may be made to copper, stone, or zinc. It may be made an adjunct to an enamel process. It will, probably, become very extensively used in ornamentation. We see a most important position for it in photographic printing on earthenware and china, as a transfer exactly similar to that now used in the potteries, but with photographic image, may be without difficulty produced. Various other uses may also follow, which we need not glance at now.

We have given a simple, unvarnished, and unexaggerated sketch of the process and its results, avoiding everything like enthusiastic epithet, feeling that, having reference to the past, we best serve our readers and Mr. Pouncy by doing so. We have, nevertheless, been very highly delighted with what we have seen and produced; and, if all our anticipations and hopes in connection with the subject are fulfilled, it will prove one of the most important steps yet secured in the progress of the art.

We should add, in conclusion, that Mr. Pouncy's arrangements in connection with his patent appear to us to be liberal. He is arranging to supply the prepared paper, ready for exposure, to any one at about a guinea a quire, so that amateurs will be able to experiment without a license. To professional photographers, wishing to use the process for commercial purposes, he intends to supply an annual licence for five guineas. To professional printers this amount will

be a very unimportant consideration, if the process turn out as successful in general practical operation as it has done in our hands.

PHOTO-ENGRAVING.

THE vast economic value of a thoroughly good and simple method of photographic engraving can scarcely be over-estimated, and from the earliest history of photography efforts have been made, with more or less of success, to secure such a process. Most of our readers are familiar with the various methods attempted, from Fizeau's process of etching Daguerreotype plates down to a recent date. Whilst recently in Paris we saw specimens, apparently of much promise, of two new processes of photographic engraving, the details of which, however, were not stated. A month or two ago we were favoured by a visit from M. De la Blanchere, who showed us a number of exceedingly fine proofs from plates produced by his "heliographic machine." They consisted of portraits, about 10 by 8, of public men popular in France, from fine negatives by Nadar. As pictures and portraits they are exceedingly fine—bold and artistic, and, at the same time, full of photographic half-tone. They are, we are assured by M. De la Blanchere, entirely untouched. At the same time, they bear throughout the marks of a tool sufficient to induce at the first glance a doubt of this statement. These markings of the tool are, however, probably due to the treatment of the plate by the method adopted by mezzo-tint engravers, and they are doubtless really untouched, so far as that term is meant to imply that the plates are not worked upon by the engraver, and that they owe nothing to the hand of man. A bitumen process is employed in obtaining the plate, and the whole result, which is very fine indeed, is, we are assured, due to the action of light and the "heliographic machine."

The best example of photo-engraving which we have yet seen, however, is by a process invented by Mr. D. C. Dallas, a gentleman who was associated at one time—to his cost, as he informs us—with the Photo-galvanographic Company, which came to grief some years ago. A specimen before us, "Kenilworth Banqueting Hall," from a negative taken expressly for the purpose by Mr. Bedford, is, we are assured—and the print bears evidence to the fact—from an entirely untouched plate. It has excellent gradation of half-tone, and is bold and vigorous. A few touches by a skilled engraver would make it a perfect picture. We have it here exactly as produced by chemical action, in order to illustrate the capabilities of the process.

We regret that, owing to the unsatisfactory protection afforded by the existing Patent Laws, Mr. Dallas, at present, does not perceive any method of reimbursing himself for the cost—some thousands of pounds—of his initiatory labours, except in keeping the working and secret of his process in his own hands. We subjoin his communication on the subject:—

In consequence of the very questionable protection afforded by the Patent Laws, I deem it advisable at present not to publish the details of my process. I have already sacrificed much to the "idea" of engraving photographs, and as I believe I have now solved the problem in a satisfactory manner, I am naturally anxious to remunerate myself. At a future time I may make a proposal the effect of which, if agreed to, will be to enable others to work my process.

From the encomiums passed by highly qualified judges on the specimen I now submit—Kenilworth Banqueting Hall, from a photograph by Bedford—I think I am warranted in saying that I have solved the problem of successfully engraving photographs. But I should not consider myself entitled to the merit of this discovery were the specimen above mentioned touched up by the graver, or even the result of a happy chance. I am glad to be in a position to say that the specimen has only required careful cleaning, and that unless my head and my hands fail me the result is certain. I can guarantee to produce, in a period varying from one to three weeks, an engraved plate from a photograph. In this plate, that which constitutes the

essence of the photograph and the despair of hand labour—*fac-simile* even to minute and almost microscopic detail—shall be present. To attain this result, all that I require is a good reversed negative (easily produced by reversing the glass), and a positive print merely fixed with hypos, not toned.

The methods which have hitherto given most promise are the bitumen process, photoglyphy, and photogalvanography. The other processes of photolithography and photozincography, from their very nature, cannot rival the richness of plate printing. The bitumen process and photoglyphy are essentially etching processes, and involve much hand labour and consequent loss of fidelity. Photoglyphy is the least satisfactory of the two, as the etching ground employed is of a very delicate nature, and the photographic chemical, bichromate of potash, has the unfortunate quality of destroying detail, the longer it is submitted to actinic influence.

The most important step in advance was photogalvanography. This process came into my hands when in a most crude and impracticable condition, and after it had been given up as useless by others. By much patient labour I succeeded in making it practical, and the process has ever since been worked with the improvements which I effected. I was not permitted to reap the fruit of my labours, and after a considerable sum had been expended, by my then partners, to develop the process in a direction to which it was wholly unsuitable, the process has been almost abandoned.

Photogalvanography, like photoglyphy, depends on the peculiar action of bichromate of potash, in combination with gelatine. In this lies its weakness. It loses detail—the more so as it requires a very long exposure, sometimes upwards of six hours, and then without any certainty that the right exposure has been attained. There are consequently numerous failures from this one cause alone.

I experimented long with this process, and found that the result was due to chromic acid. In other words, that with a composition merely of chromic acid and gelatine, a raised image with granulation could be produced. From this raised image the electrotype plate was subsequently made. Independently of the loss of detail, and the uncertainty in the exposure—both defects inherent in the process—the granulation was of a peculiar zig-zag and wiry character, which was of great value in the vigorous parts of the picture, but became broken or unconnected in the half-tones and fine details. This led to a pretty free employment of the graver and roulette, just in the very parts which made hand labour expensive. The process, indeed, was never capable of the high flight which was attempted, and, as I predicted, it broke down. Where expense was no object, the graver was a great assistance, but it lessened the value of the *fac-simile*.

In photoglyphy and photogalvanography, the results are obtained from a positive impression.

It was after experimenting some time with photogalvanography that it occurred to me to strike out in a different direction. Any one acquainted with engraving is aware that aqua-tint and "chalk," or stippling, produce fine grain, half tones, and detail. The problem I set myself was, how to imitate this combination. The aqua-tinter employs common resin dissolved in spirits of wine. This poured over his plate evaporates, and leaves numerous globules of resin attached to the surface. The size of these globules depends on the proportion of resin to spirit. When the acid is put on the plate the resin acts as a resist, and a tint is produced in the intermediate parts. If the plate were now electrotyped before the removal of the resin, and a print taken from the electrotype, the resin parts would give a kind of stipple or "chalk" marks, interspersed with tint. It is something similar to this which I have succeeded in imitating, with peculiarities *sui generis*, by photoglyphy and the electrotype. I can also, as it were, modify the size of the dots, obtaining them so fine as to carry almost microscopic detail; but if too fine there will be deficient depth in the dark. In this as in all things there is the happy medium, and this I believe I have secured. I commence with the negative. This should be reversed. From the negative a positive proof is taken; this I prefer not toned, but merely fixed in the sepia colour by the "hypos." I cover the negative, which must be varnished with a material from which I obtain a latent positive. This latent positive I turn by a simple process into a suitable negative, and it is with this negative that I subsequently manipulate. I can time the exposure to a nicety, a few seconds over or under making an inappreciable difference. The excess or deficiency must not, however, extend to minutes

If necessary, I can electrotype direct upon my material; but as this might lead to the discovery of part of my process, I prefer to make a different kind of matrix.

I should have been glad to have taken out a patent, in order to grant licences, but as the lawyers say no patent is valid till well litigated, I prefer to run the risk of competition, which after all is of more benefit to the Arts than monopolies such as the present Patent Laws permit.

THE DIFFICULTIES OF LIME TONING.

BY JABEZ HUGHES.

IN last week's NEWS appeared a letter signed "Cha-meal-ion," written apparently "half in joke but all in earnest," complaining of the difficulties encountered in using a lime toning bath. I cannot say I am surprised at the narration of failures, as I know from experience how difficult it is to work a lime toning bath without meanness. As "Cha-meal-ion" is evidently a person of intelligence and experience, there must be some weak point, though glancing at what has been written on the subject I cannot detect it. Meanness, however, is not peculiar to the lime toning baths, though it certainly has a greater tendency to be shown with their use. For this reason I do not think the lime toning process will ever be in general use. I have practised this process for a considerable time, and have had the opportunity of seeing it worked out by my several assistants. I have been at some times elated with the beautiful result, and at others depressed with the miserable failures; and the general conclusion I draw is, that more pains and skill are required to produce good results with it than with the usual ones containing acetate, phosphate, or carbonate of soda. "Cha-meal-ion" may rest assured that others have had their failures as well as himself, but few have so flaukly and jocosely proclaimed them.

I do not think that any of the toning baths depend for their proper working on such delicate conditions as this chloride of lime one. When I first purchased the late Mr. Lacy's business I found a German printer there using the lime toning; and, keeping a photographic depôt and selling albumenized paper, as I did, I naturally wished to introduce my own wares, but the printer told me "dere vas only von kind of baper dat vould do, and I must have dat." Many quires of paper were found on the premises, good paper for other toning processes, but I was told that "it had all been dried, and vos bad; it did not suit the doning bath." When I proposed to print in another house I alarmed the printer, who exclaimed, "I must have de same water; dere is only von vater dat vill do vor de briuting, 'specially vor de doning bath." In this manner I was introduced to the peculiar conditions under which the lime toning bath could be successfully worked.

It would scarcely be necessary to give "Cha-meal-ion" a fresh formula, after he has failed in those already published, or I might refer him to the new edition of my Manual, in which the subject is discussed, but the truth is that there cannot ever be a complete formula, because the minor modifying causes cannot be embraced. Let "Cha-meal-ion," however, try and work out a formula for himself. Let him take two solutions; one of saturated solution of carbonate of lime, say three ounces, and one of saturated solution of chloride of lime, say two ounces. Mix these two solutions in the proportions given, and add forty-five minims of the mixture to one grain of chloride of gold in solution. This bath, diluted to, say, eight ounces of water, may be used immediately, but will be better for waiting twenty-four hours. Wash the prints as usual, and tone them. If they are mealy, reduce the proportion of the chloride of lime, or increase the proportion of carbonate of lime. If the prints are not mealy, but refuse to take a black tone and become blue, increase the chloride of lime until the black tones are obtained. If too much chloride of lime is used, meanness is set up instantly, before toning even begins. Upon the harmonious proportion of the chloride of gold, chloride of

lime, carbonate of lime, the amount of free hydrochloric acid in the gold solution, as well as the nature of the albumenized paper, depends the tone of the print. It will thus be seen that a formula that succeeds in one person's hands may easily fail in another's. The so-called saturated solution of chloride of lime may, in "Cha-meal-ion's" case, contain more or less than in mine; the same with the carbonate; and the acidity of the gold solution will be quite variable, to say nothing of the nature of the paper. Can it be surprising, then, that a "Cha-meal-ion" may fail where an Ommegeanck succeeds? The Parkinson formula is one that he worked out himself from the Ommegeanck; he does not pledge himself it will succeed with others, he only knows it is just the thing for himself. The formula I have proposed for "Cha-meal-ion" to start with is successful with me just now, but next week, if I open a fresh ream, I may find the new paper requires a variation of the toning bath to suit it.

To conclude, I would urge on "Cha-meal-ion" and others who may wish to try the lime toning, that they must make a liberal allowance, in following the formulae of others, for those minor circumstances that influence the result—that they must trust rather to the general spirit of the instructions than the precise details.

I trust that "Cha-meal-ion" may find some of the hints given to be useful, and as a proof that clear and brilliant prints without any meanness can be produced by the lime toning, I enclose a few.

Ryde, I. W.

PHOTOGRAPHIC CHEMICALS:

THEIR MANUFACTURE, ADULTERATION, AND ANALYSIS.

If it is desired to obtain pure manganate of potash in the crystalline form from *mineral chameleon*, it is dissolved in a small quantity of pure water, the solution decanted from a little sesquioxide of manganese which may be deposited, and evaporated over oil of vitriol under the receiver of an air pump. Green crystals will be deposited, which are the salt in question. These crystals are decomposed by water, yielding a red solution of permanganate of potash and brown peroxide of manganese, caustic potash being separated at the same time. The formula for this decomposition being as follows:—

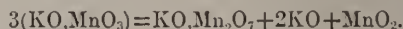

When free potash is present the decomposition is not so rapid, and hence, when the crude substance is dissolved in a large quantity of water, the decomposition taking place gradually causes the liquid to assume various colours. The solution is dark green at first, but rapidly changes through blue, violet, and purple, to carmine red, in proportion as the excess of potash is removed from the salt by the water, and by the carbonic acid of the air. The changes occur with greater rapidity if the water be in large excess, or if it be hot.

Permanganate of potash is always prepared from the manganate, by making use of the reaction shown in the above equation. This salt can be purchased at most chemists', both in solution and in the crystalline form; but as some of our readers may wish to prepare it for themselves, we give the process which we have found most effectual; it is the one originally recommended by Gregory. Add to a finely divided mixture of 8 parts of peroxide of manganese and 7 parts of chlorate of potash, a solution of 10 parts of hydrate of potash in a very small quantity of water; evaporate to dryness, during which a small quantity of mineral chameleon is formed; ignite the finely pounded mass in a crucible till the whole of the chlorate of potash is decomposed (for which a low, red heat is quite sufficient); reduce the semi-fused mass to coarse powder, and boil it in several times its weight of water. An insoluble deposit will be formed, which allow to subside and separate by decantation. Evaporate the clear solution rapidly, during which time a

fresh precipitation of peroxide of manganese will be precipitated. Separate this by decantation, and leave the solution to crystallize by cooling. When all the crystals have deposited, pour the supernatant liquid off, and wash the crystals with a small quantity of cold water; dissolve them in the smallest possible quantity of boiling water, and leave the solution to crystallize on cooling. In this manner needles are obtained three-quarters of an inch in length, and amounting in weight to about a third of the peroxide of manganese employed. In order to avoid the unavoidable losses arising from decanting the solutions, they may be filtered, employing a funnel having its neck stopped with asbestos. Permanganate of potash crystallizes in dark purple needles having a sweetish taste; it does not alter the colour of test papers, and is not deliquescent. When heated, the crystals decrepitate, evolving oxygen. As might be supposed from the great amount of oxygen they contain, friction in a mortar with substances greedy of oxygen, such as phosphorus, sulphur, &c., produces detonation. Permanganate of potash dissolves in 16 parts of water at the common temperature, forming a purple solution. When potash is added, this colour changes, through violet and blue, to green. When ammonia is added to the solution, its hydrogen is oxidized with precipitation of peroxide of manganese. All organic substances exert a deoxidizing action on the solution. Alcohol acts with peculiar rapidity; gum, sugar, paper (as, for instance, when used to filter the solution) act more slowly. Decolorization also takes place when the liquid is exposed in open vessels, organic particles falling into it from the air, and carbonic acid at the same time combining with the potash. In purifying water by means of permanganate of potash, Mr. Condy has pointed out that not only is organic matter removed, but lead is also separated. Every one knows how deleterious, but, unfortunately, how common an ingredient this metal is in water after being stored in lead cisterns. When permanganate of potash is added to water containing oxide of lead in solution, it gives the metal an additional equivalent of oxygen, converting it into binoxide of lead, an insoluble brown powder. In a similar way, iron may be separated from water.

The method of testing and purifying water from organic impurities is very simple. Prepare a solution of 10 grains of permanganate of potash in one ounce of distilled water. Take a tumbler of the water to be tested, and add to it, drop by drop, the permanganate solution, until the pink colour which it communicates to the liquid does not disappear on standing. If the water be perfectly pure and free from organic matter, the first drop will produce a permanent pink tinge throughout the whole of the liquid, which no amount of standing will cause to disappear. If common distilled water be used containing the usual amount of organic matter, the colouration produced by the first drop will disappear in the course of five or ten minutes, and a brown turbidity will be visible in the liquid. Generally speaking, another drop will be required to render the pink colour permanent. A very good means of comparing the qualities of various waters in respect to their organic impurities is to arrange a series of glasses side by side, each containing a certain quantity, say 10 ounces, of the water, and to add one drop of the permanganate solution to each in rotation, repeating the addition at intervals of five minutes. The number of drops required to be added before the pink tinge becomes permanent will be a very good measure of the relative amounts of organic matter present. In employing this process for purifying water in quantity sufficient to employ for photographic operations, the permanganate can be added directly to the water contained in a stone vessel or cistern. An ounce or so of the solution of permanganate may be added at a time, and the water may be stirred up with a glass or china rod. A quarter of an hour should be allowed to elapse between each addition of permanganate solution. When the decolorization of the pink water proceeds with difficulty it is a sign that the point of purification is nearly

reached, and the addition of the pink liquid may then proceed cautiously, half or a quarter of an ounce at a time. So long as decolorization takes place more permanganate should be added, and the water should eventually have a very slight excess of pink tinge in it. If this purification is employed on a small scale, say one or two gallons only, it can be allowed to remain at rest for a few hours, and then be filtered through clean white filtering paper. This effects two objects. It separates mechanically the precipitated peroxide of manganese and other impurities which may have been deposited during the act of purification, and it also removes the last trace of permanganic acid which has purposely been added in excess. If the purification has taken place in a cistern, the deposit may simply be allowed to subside, and the clear liquid can be drawn off. If exposed to the air the pink colour will gradually disappear in a day or two, or it may be at once removed by putting a few lumps of freshly burnt charcoal into the water. For all photographic purposes water so purified (except it contains an unusual proportion of earthy or saline impurities) is better than the common run of distilled water; the small amount of potash salts introduced in the process of purification being unimportant in comparison with the large quantity of injurious matter separated.

Critical Notices.

THE PRINCE CONSORT MEMORIAL. PHOTOGRAPHED BY DR. DIAMOND.

WE are uncertain at the moment we write whether these photographs are intended for publication or for private circulation only. If the latter, it is, we think, matter for regret, as they afford the only means by which the majority of those interested can become acquainted with one of the noblest works in monumental sculpture which this or any country possesses. The fact that a commemorative memorial, combining the double aspects of a record of the first Great Exhibition, and a tribute to the late Prince Consort, with whose memory that Exhibition will ever be associated, should be erected in what is virtually a private garden, belonging to the Royal Horticultural Society, is matter for general regret, the greater that its chief attractions consist in a series of sculptures which go far to redeem us from the national reproach of inferiority which has attached to so much of our public statuary.

The memorial, which is of red and grey granite, is in the general form of a temple, with the base projecting at the four corners, so as to carry four colossal bronze figures representing Europe, Asia, Africa, and America. The whole is surmounted by a colossal statue in bronze of the Prince Consort in the costume of the Master of the Order of the Bath. The figures are by Mr. Joseph Durham, whose original design—which has, however, undergone some modification—was selected from amongst those of about fifty competitors. Nothing can exceed the grandeur of these allegorical figures, which are treated with a freshness and power altogether unlike the old conventional types. America, for instance, is no longer the Red Indian maiden attired as a huntress, but a female figure of European type, at once beautiful and powerful, resting her arm upon the axe which clears the forest to prepare for the progress of civilization. In all the figures there is manifested a careful study of ethnological types, and a rare feeling of the minute as well as the great elements of symbolical expression. Altogether, apart from the powerful individualism and poetically representative character of each figure, they are very fine as sculptures, the masses grand and simple, yet perfect in every detail of artistic truth and finish. Photographers may be proud to claim in Mr. Durham a member of the council of the Photographic Society.

To those who are fortunate enough to be familiar with the photographs of Dr. Diamond, it will be quite sufficient to

say that these pictures are worthy of him. They consist of whole plate views of each of the five large figures, and one of the same size of the complete memorial. Notwithstanding the difficulty of perfectly rendering bronze figures, owing to their non-actinic colour, these are soft, brilliant, round, and perfectly well modelled, doing justice to the simple grandeur of Mr. Durham's noble sculptures.

PHOTOGRAPHS TAKEN AT SANDRINGHAM. By THE LONDON STEREOSCOPIC AND PHOTOGRAPHIC COMPANY.

To make good pictures out of unpicturesque subjects is a task more difficult than making bricks without straw. All that could be done for Sandringham in the shape of good photography and well chosen positions, has been done, however, by Mr. England and the staff of operators sent down by the Stereoscopic Company. The result is some really pleasing pictures of the hall and grounds, and surrounding neighbourhood, both in stereoscopic and 10 by 8 pictures. In the production of portraits the task was easier. The Princess, always graceful and charming—the Prince, always pleasant, easy, and a gentleman, make good pictures in any style; and of the score of different positions, &c., produced by the company, there is not one bad. A group of the Prince and Princess, the latter sitting on a rustic garden-seat, and the Prince leaning against it, forms at once as pleasing a picture and satisfactory likenesses as have yet been produced. This picture is published both in stereoscopic size and as a vignettted 10 by 8 picture for framing. All the portraits are good, but the group is a gem. We perceive that the company has recently devoted some attention to the production of neat, cheap frames for photographs, which are worth the attention of photographers.

PRIZE PICTURES. By MEMBERS OF THE AMATEUR PHOTOGRAPHIC ASSOCIATION.

All the prize pictures of the Amateur Association are this year good, most of them possessing pictorial as well as photographic merit. If we were disposed to be hypercritical, we should again be inclined to question on what ground the degrees of merit were decided, as there is an equality of excellence in all the pictures, which renders it difficult to say whether those taking the fourth prize are not in all respects equal to those taking the first. The "Hall of Columns," at Carnac, by Mr. Remington, for instance, which takes a fourth prize, is, of its kind, perfect; and "Hill and Tank," an Indian picture, by Lieut. Impey, also taking a fourth prize, would be, were it not for its stopped-out sky, perhaps the most meritorious picture of all. Mr. A. Henderson's instantaneous photo, "The Mountain Maid," a charming whole-plate vignettted picture of a steamer on a Canadian lake, with water, distant foliage, and clouds, all well made out, takes a third prize. The second prize is awarded to a pair of whole-plate subject pictures, "Going a Milking," and "Been a Milking," in which skilful use is made of a few real rustic accessories, giving *vraisemblance* to the general effect produced by a painted background. The composition is good, and the photography excellent; but we should have liked to have seen less consciousness in the model, and different scenery, or the same scene from a different point, instead of the same painted background in the same position in each. The two first prizes are carried off by Mr. Baynham Jones and Major Gresley; the first, for a picture containing much poetry, although not a perfect photograph, called "A Misty Morning;" and the second, for a pair of excellent photographs entitled "Sunshine" and "Shade:" both the photographs are good; but there is not sufficient of the characteristics of sunshine and shade in the pictures to justify the titles. We think, altogether, the pictures are an advance upon those of last year.

SPECTRA OF THE STARS.*

At the meeting of the Royal Astronomical Society held in April last, the Astronomer Royal gave an oral account, illustrated by drawings, of the apparatus which had been prepared at the Royal Observatory, Greenwich, for the observation of the spectra of stars, and of some of the principal results obtained. In the drawing below, the first

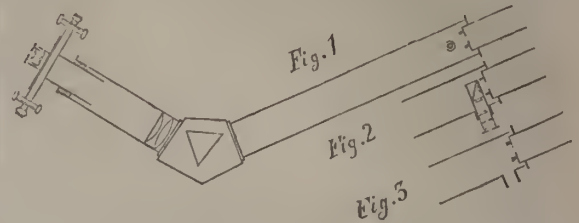

figure represents the entire apparatus, in section; the second and third figures represent the right-hand portion of the apparatus in a section through the axis of the long tube, but at right angles to the former section.

In Fig. 1 the smaller tube at the right hand is for insertion in the socket upon the breech-piece of the telescope of the great equatorial. To carry the apparatus steadily (great accuracy of position is not needed), a temporary frame is screwed to the sides of the telescope tube. The right-hand tube is thrust into the socket so far that the image of the star is formed in the moderately small hole in the inner end of that smaller tube. The pencil of light from the object-glass, which has converged to form the image of the star, then diverges and falls in a wide and divergent state upon the prism; after emergence it is received on a combination of lenses, which causes the pencils for the different colours to converge. It is seen thus that a spectrum may be formed at the place of the micrometer; it is necessary now to explain how breadth is given to the spectrum.

For this purpose the prism is not placed in the position of minimum deviation, or the position in which the angles of incidence and emergence are equal. It is so inclined that the angle of emergence is greater than the angle of incidence. With this arrangement, the change in the degree of divergence of the extreme rays of the pencil is different as regards (on the one hand) rays in the upper and lower parts of the pencil, or in the plane of the paper, and (on the other hand) rays in the plane perpendicular to the paper. The difference is such that, when after passing through the lenses the former have converged so as to form a pure spectrum at the place of the micrometer, the latter have passed convergence, and therefore the spectrum has breadth. The position of the prism, which gave a convenient breadth to the spectrum, was determined by trial. It is necessary to remark that the lenses must not be achromatic; they are, in fact, made of dispersive flint glass; if achromatic, the spectrum would have been formed in a plane inclined to the plane of the micrometer. The whole of these peculiarities were calculated numerically on geometrical theory before the construction was attempted.

This principle may be regarded at present as experimental. In simplicity of construction it is much superior to the principle of causing the pencils which pass through the prism to consist of parallel rays, which requires the use of two achromatic object-glasses and one cylindrical lens; but it is not yet certain whether or not it defines the spectral lines with equal sharpness.

It is necessary now to explain how reference is made to the lines of the solar spectrum. In fig. 1, near the right-hand extremity of the large tube, a small circle may be seen. This is a view (not properly in section) of a small socket, which in fig. 3, lower side, may be seen empty, and

* Monthly Notices of the Royal Astronomical Society.

which in fig. 2 contains a small eye-piece. It is thus used. A tube, containing at its end a very small hole (possibly $\frac{1}{10}$ inch in diameter) is thrust, in a definite position, into the right-hand tube of fig. 1, till the small hole is in the focal plane of the telescope image. In this state the telescope is turned to the sun; the small hole represents a star of solar matter; and its spectrum may be observed and measured. An eye-piece with diagonal reflector, and carrying a wire in its focus, is thrust into the small socket, as in fig. 2, and the position of the solar hole with reference to the wire is carefully observed. Then, when a star is to be observed, the small eye-piece is thrust in, the telescope is moved till the star's image has the same position in regard to the wire which the solar hole had, and then it is certain that the star occupies precisely the place of the solar hole; then the small eye-piece is withdrawn, and the spectrum is observed, and measures are made with the micrometer.

For reading the comb of the micrometer there is an annular reflector to illuminate the field, not shown in the drawing.

The following sketch exhibits lines whose positions have been measured by Mr. Carpenter; numerous lines have been seen, but not measured.

	A	a	B	C	D	E	b	F	G	H
Sun										
α Orionis										
μ Geminorum										
α Ceti										
δ Virginis										
Sirius										
Castor										
Procyon										
γ Geminorum										
β Aurigæ										
Regulus										
θ Aurigæ										
Spica										
γ Virginis										
Capella										
β Leonis										
Aldebaran										
Arcturus										
β Tauri										
Pollux										

On this sketch Mr. Carpenter remarks:—

This diagram is only intended to show the positions of the lines; no attempt has been made to illustrate their characters or their different intensities. The stellar lines are generally nebulous, resembling the solar line H; in the

first four stars on the diagram they are, however, much more diffused on the side opposite to the red end of the spectrum.

Since these observations were communicated to the Society, two more lines have been detected in the spectrum of *Arcturus*; one coincident with solar D, the other between it and solar C.

G. B. A.

MR. POUNCY'S NEW PATENT PROCESS FOR PERMANENT PRINTING.

(Specification.)

My said invention relates to certain improvements in obtaining, transferring, and printing from photographic and any other pictures or images, and also in preparing the materials for such processes; the main or principal feature of my invention consisting in the employment of a sensitive or sensitized ink or composition on which pictures or images may be produced by the agency of light, and which may be transferred or printed from in the manner hereinafter mentioned.

The surfaces employed for the reception of the pictures or images may be paper, silk, linen, cotton, or mixed fabrics, leather, wood, ivory, glass, porcelain or stone, or surfaces of metal or of metallic alloys may be used, or any other surface. The surface proposed to be employed is coated with an ink or composition consisting of carbonaceous or other colouring matter (according to the colour or tint of the picture desired to be produced), fat, tallow, or oil, bichromate of potash or bitumen of Judæa, or both of such last-mentioned substances, and benzole, turpentine, or other hydrocarbon or analogous spirit. The respective proportions of the several ingredients hereinbefore mentioned will vary with the circumstances attending the operation.

The mode of compounding such ingredients, and the necessary proportions thereof, will be well understood by persons conversant with the preparation of similar or analogous inks or compositions, with the addition of the two last mentioned substances dissolved in either of the spirits before named. I may mention, however, that if the photographic picture or image is to be transferred on to stone or any other surface suitable for being printed from, a larger quantity of oil or fatty matter is employed in preparing the ink or sensitive composition than when the picture or image is simply taken on paper or any other surface, and is to be used merely in that form. The ink or composition must be prepared and applied to the surface of the material employed in the dark, or in a place from which the actinic rays of light have been excluded, or by an artificial light which does not act photographically. The coated surface is to be dried and excluded from the light until it is about to be used, when a photographic picture or image may be produced thereon by any of the usual and known methods applicable to the purpose.

When the picture or image is to be produced by means of a negative picture or image applied to the sensitized surface prepared as aforesaid, and the substance or material is sufficiently transparent to allow the rays of light to act through the same, the negative picture or image may be placed on the uncoated surface and the light applied so as to act on the coating through the transparent substance or material.

The rays of light having hardened the parts required, and produced the desired effect on the sensitized coating, the parts not acted on thereby remaining soluble are then washed off with benzole, turpentine, naphtha, or other hydrocarbon solvent. The picture or image will thus be left upon the surface employed in printing-ink, or in a composition in the nature of or analogous to printing-ink, and from which impressions can be obtained as hereinafter mentioned.

The pictures or images obtained in the manner hereinbefore mentioned are applicable to a great variety of purposes, both useful and ornamental. They may be preserved simply as works of art, or they may be transferred (if a suitable material for receiving the sensitive coating has been employed) to the surface of porcelain or other ceramic manufactures, and "burnt in" or permanently imparted thereto, according to the well-known methods of performing such operations.

When the sensitive ink or composition is applied to a lithographic stone, for the purpose of printing therefrom, the surface of the stone must be "grained" before the application of

the ink or composition, and the surface of the coating should be also "grained" after it has been laid on the surface of the stone. The process of "graining" is well understood, and, therefore, I need not describe the same. Before transferring the picture to the stone, the surface thereof should be moistened with water, and it should be used in the press in a cold state, and not heated, as is frequently the case in ordinary lithographic printing.

I have not detailed the optical arrangements for primarily obtaining the pictures or images, as such arrangements do not form any part of my said invention.

Having thus fully described and ascertained the nature of my said invention, and also the manner in which it is to be performed, I would observe in conclusion that what I consider novel and original, and therefore claim as constituting my said invention, are:—

Firstly, the production of photographic pictures or images by means of the sensitized ink or composition hereinbefore mentioned, or any sensitized ink or composition analogous or equivalent hereto, in the manner hereinbefore substantially set forth and described.

Secondly, the methods of transferring the photographic pictures or images so produced as aforesaid to the surfaces of such substances as hereinbefore particularly mentioned, and of printing from such surfaces as are adapted for such operation, as hereinbefore substantially set forth and described.

And thirdly, the methods of preparing the several materials employed in the process aforesaid, as and for the purposes hereinbefore set forth and described.

DOINGS OF THE SUNBEAM.*

We have copied a picture, but we can take a portrait from Nature just as easily, except for a little more trouble in adjusting the position and managing the light. So easy is it to reproduce the faces that we love to look upon; so simple is that marvellous work by which we preserve the first smile of infancy and the last look of age: the most precious gift Art ever bestowed upon love and friendship!

It will be observed that the glass plate, covered with its film of collodion, was removed directly from the nitrate of silver bath to the camera, so as to be exposed to its image while still wet. It is obvious that this process is one that can hardly be performed conveniently at a distance from the artist's place of work. Solutions of nitrate of silver are not carried about and decanted into baths and back again into bottles without tracking their path on persons and things. The *photophobia* of the "sensitized" plate, of course, requires a dark apartment of some kind: commonly a folding tent is made to answer the purpose in photographic excursions. It becomes, therefore, a serious matter to transport all that is required to make a negative according to the method described. It has consequently been a great desideratum to find some way of preparing a sensitive plate which could be dried and laid away, retaining its sensitive quality for days or weeks, until wanted. The artist would then have to take with him nothing but his camera and his dry sensitive plates. After exposing these in the camera, they would be kept in dark boxes until he was ready to develop them at leisure on returning to his *atelier*.

Many "dry methods" have been contrived, of which the *tannin process* is in most favour. The plate, after being "sensitized" and washed, is plunged in a bath containing ten grains of tannin in an ounce of water. It is then dried, and may be kept for a long time without losing its sensitive quality. It is placed dry in the camera, and developed by wetting it and then pouring over it a mixture of pyrogallic acid and the solution of nitrate of silver. Amateurs find this the best way for taking scenery, and produce admirable pictures by it, as we shall mention by-and-by.

In our former articles we have spoken principally of stereoscopic pictures. These are still our chief favourites for scenery, for architectural objects, for almost everything but portraits,—and even these last acquire a reality in the stereoscope which they can get in no other way. In this third photographic excursion we must only touch briefly upon the stereograph. Yet we have something to add to what we said before on this topic.

One of the most interesting accessions to our collection is a

series of twelve views on glass, of scenes and objects in California, sent us with unprovoked liberality by the artist, Mr. Watkins. As specimens of art they are admirable, and some of the subjects are among the most interesting to be found in the whole realm of Nature. Thus, the great tree, the "Grizzly Giant," of Mariposa, is shown in two admirable views; the mighty precipice of El Capitan, more than three thousand feet in precipitous height,—the three conical hill-tops of Yo Semite, taken, not as they soar into the atmosphere, but as they are reflected in the calm waters below,—these, and others, are shown, clear, yet soft, vigorous in the foreground, delicately distinct in the distance, in a perfection of art which compares with the finest European work.

The "London Stereoscopic Company" has produced some very beautiful paper stereographs, very dear, but worth their cost, of the Great Exhibition. There is one view, which we are fortunate enough to possess, that is a marvel of living detail,—one of the series showing the opening ceremonies. The picture gives principally the musicians. By careful counting, we find there are *six hundred faces to the square inch* in the more crowded portion of the scene which the view embraces,—a part occupied by the female singers. These singers are all clad in white, and packed with great compression of erinoline,—if that, indeed, were worn on the occasion. Mere points as their faces seem to the naked eye, the stereoscope, and, still more, a strong magnifier, shows them with their mouths all open as they join in the chorus, and with such distinctness that some of them might readily be recognized by those familiar with their aspect. This, it is to be remembered, is not a reduced stereograph for the microscope, but a common one, taken as we see them taken constantly.

We find in the same series several very good views of Gibson's famous coloured "Venus," a lady with a pleasant face and a very pretty pair of shoulders. But the grand "Cleopatra" of our countryman, Mr. Story, of which we have heard so much, was not to be had—why not, we cannot say, for a stereograph of it would have had an immense success in America, and, doubtless, everywhere.

The London Stereoscopic Company has also furnished us with views of Paris, many of them instantaneous, far in advance of the earlier ones of Parisian origin. Our darling little church of St. Etienne du Mont, for instance, with its staircase and screen of stone embroidery, its carved oaken pulpit borne on the back of a carved oaken Samson, its old monuments, its stained windows, is brought back to us in all its minute detail as we remember it in many a visit made on our way back from the morning's work at La Pitie to the late breakfast at the Café Procope. Some of the instantaneous views are of great perfection, and carry us fairly upon the Boulevards as Mr. Anthony transports us to Broadway. With the exception of this series, we have found very few new stereoscopic pictures in the market for the last year or two. This is not so much owing to the increased expense of importing foreign views as to the greater popularity of *card portraits*, which, as everybody knows, have become the social currency, the sentimental "greenbacks" of civilization, within a very recent period.

We, who have exhausted our terms of admiration in describing the stereoscopic picture, will not quarrel with the common taste which prefers card-portrait. The last is the cheapest, the most portable, requires no machine to look at it with, can be seen by several persons at the same time—in short, has all the popular elements. Many care little for the wonders of the world brought before their eyes by the stereoscope; all love to see the faces of their friends. Jonathan does not think a great deal of the Venus of Milo, but falls into raptures over a card-portrait of his Jerusha. So far from finding fault with him, we rejoice rather that his affections, and those of average mortality, are better developed than their taste; and lost, as we sometimes are, in contemplation of the shadowy masks of ugliness which hang in the frames of the photographers, as the skins of beasts are stretched upon tanners' fenees, we still feel grateful, when we remember the days of itinerant portrait-painters, that the indignities of Nature are no longer intensified by the outrages of Art.

The sitters who through the photographer's establishment are a curious study. They are of all ages, from the babe in arms to the old wrinkled patriarch and dames whose smiles have as many furrows as an ancient elm has rings that count its summers. The sun is a Rembrandt in his way, and loves to track all the lines in these old splintered faces. A photograph of one of them is like one of these fossilized sea-beaches where the

* Continued from page 356

rain-drops have left their marks, and the shell-fish the grooves in which they crawled, and the wading-birds the divergent lines of their foot-prints,—tears, cares, griefs, once vanishing as impressions from the sand, now fixed as the vestiges in the sand-stone.

Attitudes, dresses, features, hands, feet, betray the social grade of the candidates for portraiture. The picture tells no lie about them. There is no use in their putting on airs; the make-believe gentleman and lady cannot look like the genuine article. Mediocrity shows itself for what it is worth, no matter what temporary name it may have acquired. Ill-temper cannot hide itself under the simper of assumed amiability. The querulousness of incompetent complaining natures confesses itself almost as much as in the tones of the voice. The anxiety which strives to smooth its forehead cannot get rid of the tell-tale furrow. The weakness which belongs to the infirm of purpose and vacuous of thought is hardly to be disguised, even though the moustache is allowed to hide the *centre of expression*.

All parts of a face, doubtless, have their fixed relations to each other and to the character of the person to whom the face belongs. But there is one feature, and especially one part of that feature, which, more than any other facial sign, reveals the nature of the individual. The feature is *the mouth*, and the portion of it referred to is *the corner*. A circle of half an inch radius, having its centre at the junction of the two lips, will include the chief focus of expression.

This will be easily understood, if we reflect that here is the point where more muscles of expression converge than at any other. From above comes the elevator of the angle of the mouth; from the region of the cheek-bone slant downwards the two *zygomatics*, which carry the angle outwards and upwards; from behind comes the *buccinator*, or trumpeter's muscle, which simply widens the mouth by drawing the corners straight outward; from below, the depressor of the angle; not to add a seventh, sometimes well marked,—the "laughing muscle" of Santorini. Within the narrow circle where these muscles meet the ring of muscular fibres surrounding the month the battles of the soul record their varying fortunes and results. This is the "*nœud vital*"—to borrow Flouren's expression with reference to a nervous centre,—the *vital knot* of expression. Here we may read the victories and defeats, the force, the weakness, the hardness, the sweetness of a character. Here is the nest of that feeble fowl, self-consciousness, whose brood strays at large over all the features.

If you wish to see the very look your friend wore when his portrait was taken, let not the finishing artist's pencil intrude within the circle of the vital knot of expression.

(To be continued.)

Correspondence.

FOREIGN SCIENCE.

[FROM OUR SPECIAL CORRESPONDENT.]

Paris, 29th July, 1863.

MR. HART, of London, at the recent meeting of our Society, exhibited a positive printing frame, in which, by introducing a dissected screen, a positive proof can be taken from different negatives. The principal object kept in view in constructing this apparatus is the facilitating the adjustment of the negatives and screens employed in taking positives from several negatives. The small model exhibited has been made to obtain proofs upon tinted grounds, intended to be retouched, an operation that succeeds very well with proofs of small dimensions.

The following is the principle of construction:—Take a piece of very dry wood, of such size that it exceeds the dimensions of the largest proofs to be taken by 2½ to 3 inches on each side. Upon the middle of this board is placed a thick sheet of caoutchouc, selected for its eminently elastic qualities; this sheet must be a little larger than the proof to be printed in the frame. At the extremity of this sheet a rod of the same thickness is placed, which, pressing against it by means of a spring, maintains the positive paper in a fixed position. Over the whole a hinged frame is adjusted, made to move horizontally in every direction,

and so arranged that while the hinged extremity is fixed, the greater portion of the frame may be raised to permit the examination of the progress of the picture, without fear of displacing the negative, or the screen which covers a portion of the positive. This frame must be solid; it carries either one or two bars, for the purpose of keeping the glass plate or negative in the desired position in relation to the prepared surface. When the printing necessitates the employment of many negatives, it is preferable, in the inventor's opinion, to transfer the latter to gelatine or other transparent support, and to adjust them on the plate as they are adjusted in the frame, nearly in the desired position, and to arrange them afterwards in a manner conformably to the portions already printed.

M. François Pierson has invented a machine for beating albumen, which he has for a long time employed in preparing paper. The metal dasher with which the eggs are beaten, is moved mechanically with great rapidity, by means of a fly-wheel, which turns freely, and a system of eccentrics. The vessel containing the albumen turns upon itself continually during the operation. By means of this machine we can beat into froth, in the space of five minutes, as many eggs as forty minutes' fatiguing labour would not suffice to bring to the same condition.

M. Hulot exhibited to the society his method of splitting and parchmentizing paper. The paper is immersed in sulphuric acid diluted with 20 per cent. of water, and allowed to remain a given time, according to the nature and thickness of the paper which is afterwards rinsed in water. Thus treated, the paper splits with great facility, and the sulphuric acid having closed the pores, it has much more compactness, gaining in consistency while becoming thinner. It is remarkable that the colour does not change. This treatment may be applied to negative proofs only, as M. Adolphe Martin observes that this paper, after being parchmentized, cannot be waxed.

M. Lucy has communicated his method of the chemical colouration of proofs in the toning bath. The tints, which produce a remarkable effect in the flesh and drapery, are produced by a combination with the chloride, which enters into the preparation of the paper with a metallic chloride, which the operator applies, before immersion in the toning bath, to those parts of the picture he wishes to colour. The reaction then takes place, and the hue is according to the salt employed. The alkaline chlorides are the best.

Dr. Schnauss has published in the *Photographisches Archiv*, an analysis of the metallic bromo-iodo-cyanide salt, to prepare and sensitize the instantaneous collodion composed by M. Mazac. This preparation contains *iodine, bromine*, and the metals *ammonium* and *cadmium*, but no cyanide. To prepare a collodion identical with that of M. Mazac's, Dr. Schnauss gives the following formula:—

Iodide of ammonium	4 parts.
Iodide of cadmium	2 "
Bromide of cadmium	1 "

The sulphate of iron and ammonium has become, in Germany, the source of a very censurable industry. We read in the principal newspapers advertisements inviting photographers to send ten dollars, for which they will receive the formula of a new developer for very vigorous and delicate negatives without intensifying. One of these advertisers impudently asserts that "he is honored with a medal from the Great Exhibition." Upon opening the letter containing this precious formula, we find sulphate of iron and ammonium recommended. A photographer addresses the following letter to us on this subject: "X is a cheat; for the ten dollars he sends the following formula:—

Iodide of potassium	...	150 grains.
Bromide of cadmium	...	65 "
Iodide of cadmium	...	85 "
Collodion, composed of equal parts of ether and alcohol	...	31 ounces.

Develop with the solution of sulphate of iron and ammonium, according to M. Liesegang's formula."

With regard to the solution for strengthening collodion negatives, recommended by M. Valentine Blanchard, in the PHOTOGRAPHIC NEWS, M. Liesegang remarks that the solution improves by keeping. It is employed in exactly the same manner as pyrogallie acid, adding to it a quantity of the nitrate of silver solution, and pouring the mixture upon the developed proof; its action is prevented until the negative has become sufficiently vigorous. The advantages of strengthening by means of iron compared with pyrogallie acid are, that the precipitate of silver is finer, that the solution keeps better, and never fogs the shadows. The solution may be employed before or after fixing. It would appear that this new method will be very advantageous for instantaneous negatives, which are frequently very feeble.

Tartaric acid, as recommended recently by yourself may be advantageously substituted for citric acid, and, when mixed with nitrate of silver, remains clear until the necessary intensity is obtained.

Some operators recommend the saccharo-sulphate as giving much intensity to the proof.

Our Paris Photographic Society is undergoing the same kind of transformation which photography itself has undergone, by acquiring a wholly scientific character. What makes a society is less the aim with which it is established, than the influence of the members composing it. Now the Society's bulletin, of the 15th of May last, contains a list of its members, which, it must be recognised with pleasure, belong, for the most part, to the most intelligent and enlightened classes of society, both native and foreign. What is particularly remarkable, is the esteem and the *great authority* which attaches to some members whose scientific and practical works have made their names popular. As has been well remarked, this must have a considerable influence upon the future of the Society, and on the value of its labours. But a few years ago the French Photographic Society was surrounded with hostility; at Paris, especially, it was feared that the spirit of clique would prevail, and it was seriously apprehended that the Society had no future. Its works could not be placed in comparison not only with those of the Photographic Society of London, but also with many provincial societies in the United Kingdom. At the present day, every impartial person must admit that this Society, far from realizing the doubts prevalent at its *début*, has, on the contrary, fully accomplished the mission it proposed to itself, as much by the foundation of prizes intended to stimulate works upon subjects which interest photographers, as by the authority it gives to a portion of its members most eminent by their intellectual acquirements. Its *Bulletin* has become an indispensable journal to every one engaged in photography, and we recognise with pleasure that its selections from foreign journals are well made, and without the least party spirit.

We have only one objection to make to the French Photographic Society: its subscription is too high. We do not believe that we are singular in our view, for we have often heard it expressed, and we repeat the opinion of high authority when we say this. The amount of subscription should not be much more than the subscription to the *Bulletin*, for abroad the title of member of the Society brings no other advantage than the monthly receipt of the *Bulletin*. Now, to make members pay triple that amount is not good policy, and if the amount were reduced to one-half, in a very few years the number of its members would be increased tenfold.

M. M. Davanne and Girard, as is well known, have pointed out an excellent means of preserving the sensitiveness of positive paper, and preventing it from turning black—by preserving it in a box containing chloride of calcium, or other desiccating substance. It may be well for those who employ these boxes to know that the paper should first be exposed to the air in a dark place in order to acquire a certain amount of humidity, without which it will darken but very slowly in the pressure frame.

We can obtain great intensity in developing collodion plates by moistening them after cleaning, and covering them with albumen diluted with its volume of water. The dried plates are covered with collodion, and developed in the usual manner. For studies of trees and landscapes generally, pyrogallie acid is preferable to sulphate of iron.

DOES LIGHT ONLY EXIST IN THE EYE?

DEAR SIR,—There are one or two statements in the interesting paper on light, under the head "Scientific Gossip," in your last number, to which, I think, exception may be taken without incurring the charge of hyper-criticism.

The writer comes to the conclusion that the blue sky is yellow, sunshine red, &c. This may be the case if the eye were in those regions to see their colours, though they would not necessarily assume the tints fixed upon by your correspondent. I notice this assertion, not to question it, but to remark that it is at variance with what follows, viz., "All this universe is dark." If it be correct to say the sky is blue or yellow, it is incorrect to assert that it is dark. Light and darkness are both sensations (unless darkness be called the sensible absence of the sensation of light), and it requires the presence of the eye to decide how far either exist, and that place only can properly be termed dark in which an eye fails to perceive light. It is true that in one sense there may be said to be no light where there is no eye to behold it—that is, in every place external to the eye; but it is equally correct to say that in such places there is no darkness, both light and darkness being attributes of the optic sense, and not existing independent of it. It was, no doubt, the meaning of the writer, that in the universe there was no light independent of the eye, but it does not follow that the universe is dark, and such an expression is incorrect. Equally so is it to say, "Light exists only in the eye." Light is not in the eye, or in the optic nerves, but in the optic sense or sensorium, whatever or wherever that may be. The eye is merely the material instrument, perhaps the first in a series of many, by means of which what are called waves of light are prepared for their mysterious action on the sense of sight, and is as much a medium as the atmosphere through which the ethereal vibrations are propagated. Your correspondent will perceive that I do not criticise his statements, but the form in which he has put them; but when the usually received meaning of words is departed from, and they are used in an exact philosophical or metaphysical sense, the greatest care is requisite to preserve consistency in their significations, lest confusion of ideas should be introduced into the minds of those to whom it is endeavoured to convey abstruse knowledge.—Yours truly,

M. A.

SUCCESSFUL LIME TONING.

SIR,—I was a most unfortunate man, but thanks to you, am, I hope, one no longer. Unlike "Cha-meal-ion," I have not hitherto been fortunate in getting the tone I required, *i. e.*, black and white. It was, therefore, with great pleasure I read in your number of the 17th Mr. Parkinson's method of obtaining them. I instantly prepared a bath according to your directions, and having only the Saturday afternoon, at present, to experiment in, I have been through the week looking forward to that day with no small anxiety. You can imagine my dismay, then, at reading "Cha-meal-ion's" letter, for I had mixed my bath exactly as he described his. However, as I had some prints prepared on purpose, I thought I would try for myself, when, judge my surprise and joy at finding them gradually attain the long-desired rich warm black. I can, therefore, only fancy that my materials were better.

Perhaps it would be better to describe accurately the way in which I proceeded:—

I obtained from Messrs. Hopkins and Williams a saturated solution of chloride of lime, into which I put some car-

bonate of lime, shook well, and *let it stand for several days*. The paper was the *thin paper* of Messrs. Murray and Heath. Into 35 ozs. of distilled water I filtered $1\frac{1}{2}$ drachms of the lime solution, and then added 2 drachms of gold. This I used twenty-four hours after mixing. I cannot tell the strength of my silver bath, as it was one I have had in use some time. The prints were a little over-printed, then well washed, put into the toning bath out at a time, with only just sufficient to cover them, and the result was most satisfactory, and has put an end to all my troubles on this head. My time is so fully occupied professionally at present, or I would send you some proofs to look at, but as soon as I am a little more disengaged I will do so, that you may see I do not over-rate my success.—I am, dear sir, yours truly,

July 27th, 1863.

ENGINEER.

Photographic Notes and Queries.

ANGLE OF VIEW, &c.

SIR,—In the last number of the PHOTOGRAPHIC NEWS, your correspondent, "Tanno-Glycerine," asks your advice as to the form of lens best adapted for general purposes, and also for engineering subjects, bridges, &c., where a large angle of view is required, say 60° or 65°, the size of picture wanted being 11 by 9. You tell him in reply that you do not know of any lens at present catalogued which will give an angle of 60° or 65° on 11 by 9 plates.

Permit me to call your attention to the following extract from the PHOTOGRAPHIC NEWS, for March 29, 1863, page 261:—

"Mr. Collis exhibited a series of fine views in Wales, taken with Ross's 10 × 8 triple lens, on 10 × 12 plates. Also some with the lens of 8·4 focus, and some with the lens of 9·4 focus, including an angle of 60° on the base line and 66° on the diagonal. These were very much admired."

My triple lens of 9·4 equivalent focus is therefore the very lens which would answer the requirements of your correspondent, but I suppose you had for the moment forgotten that such a lens is in existence.

In fairness to yourself, to your correspondent, and to me, I must request the favour of this letter being inserted in the next number of the PHOTOGRAPHIC NEWS.—Faithfully yours,
THOMAS ROSS.

2, Featherstone Buildings, Holborn,
July 28, 1863.

[Neither the lens nor the prints referred to came under our especial attention for measurement or calculation; their exhibition at a meeting, and our incidental sight of them, were duly reported at the time, but had escaped our further recollection.—Ed.]

EBONITE BATHS.

DEAR SIR,—Having long been a subscriber to your NEWS, I take the liberty of addressing you regarding a subject which may prove beneficial to others.

Seeing ebonite so highly spoken of for baths, I immediately sent home to one of the best houses for a bath. I have had it now in use for two months and more, and have always found that after my bath had been in for a couple of days I could never take a good picture. I saw it had all the appearances of acidity, but could not make out how it had got acid. This morning being a particularly nice morning, I thought I would take some pictures. I exposed, and did everything as usual, but no negative. I immediately went to my bath and found that the acid state was enough to prevent any picture. I after emptied it out into the stock bottle, and applied a piece of litmus paper to the ebonite, it immediately turned it scarlet: I may say, this ought not to be, I should think. To prove there was nothing wrong with the bath itself, I put a little in a small glass bath I had, and instantly took everything as usual. Is this the usual behaviour of this patent material? because, if so, the sooner it is generally known the better. I put in boiling soda and water to see what effect it would have, but have not had time to try; but shall be happy to let you know, if you think it worth

knowing. Perhaps some of your numerous readers can enlighten me on this subject.—I am, dear Sir, yours faithfully,

DENNIS WRIGHT, Captain 109th Foot.

Kurrachee, Said, June 9, 1863.

June 20.—I have since tried the bath, and find it is not the slightest better now than before.

[We cannot see any possible action in ebonite which could render the bath acid; nor, if it had done so, could the same solution have worked properly at once, without any rectification, when placed in another vessel. We have had a silver solution standing in an ebonite bath for upwards of twelve months, without being in any way injured.—Ed.]

Talk in the Studio.

RESINIZED COLLODION.—Dr. Saunders Van Loo, writing to us from Amsterdam, says:—"It is more than two years that I have used this collodion, and always with the same success. Since that time, no great improvements have been made in dry plate photography, except ammonia fuming, hot developments, &c. I am sure no simpler method exists than to prepare with my resinized collodion, plates which are simply washed in ordinary water. The chlorides present in the wash water do not give any trouble. I use always the here called "duinvater," or hill water, which is conducted from a distance of four hours to Amsterdam through iron tubes. This water contains lime and iron salts. My plates keep fit for use for a long time; I have exposed and developed with success plates which were prepared for several months. Therefore it surprises me that resin-collodion is not more in use. Sometimes I read in your valuable journal about trials by some gentleman to get dry collodion by adding resin to Ponting's, Thomas', or other good collodion sorts, yet I suppose that a photographer will scarcely succeed in this way for obtaining a suitable dry collodion. Enclosed I have the honour to send you a print after a negative taken in *two minutes, with stopped view lens* (opening scarcely half an inch). I expect that the correspondence in photographic journals would not abound in so many narratives about disappointments in dry-plate work, if resin-collodion in good condition was more used.

[Some time last year, Dr. Van Loo favoured us with a bottle of his collodion for trial. Unfortunately, press of engagements delayed our trial for some months, and we then found that the collodion had lost sensitiveness by age, so that we were unable to do it justice in a trial.—Ed.]

THE DISCOVERY OF THALLIUM.—Mr. Crookes has just issued a pamphlet detailing the history of his discovery of thallium. With singular disingenuousness the French *savans* persist in attributing the discovery of the metallic nature of this element to M. Lamy, and state that Mr. Crookes is indebted to that gentleman for his knowledge that thallium was a metal. We have before alluded to the evidence on the subject, which is most conclusive, and it is unnecessary to repeat it now. M. Lamy states that he first discovered the green line of thallium in April, 1862, and that he isolated the metal in May, 1862, between the 2nd and 16th. Now the fact stands on uncontested published evidence that Mr. Crookes discovered the line in March, 1861, isolated the element in September, 1861, and exhibited the metal on the 1st of May, 1862, at the opening of the International Exhibition, upwards of a fortnight before M. Lamy announced his discovery of the metal.

MR. HEATH'S PHOTOGRAPHS.—Mr. Vernon Heath issued circulars a few days ago, inviting his friends to a private view to a series of portraits and landscapes recently taken for His Royal Highness the Prince of Wales. The views of Windsor and Frogmore include some of the most charming photographs that we have seen. Amongst the many pleasing portraits of the Prince and Princess, we were most interested in the enlargements from card pictures to whole plates, which were produced with scarcely the least appreciable loss of any kind, either in definition, delicacy, gradation, or vigour. Mr. Heath, after very long experiment in the enlargement of negatives, has come to the conclusion that the most perfect result is obtained by obtaining first a good, well-detailed transparency, using iron development, and, from this, a negative, by weak pyrogallic acid development. The perfectness of the results very emphatically recommend the method.

ART PHOTOGRAPHS.—We have received from Mr. Adam Diston, of Leven, Fife, three subject pictures produced by the camera, which display very considerable artistic power. The

best is intended to represent Alexander Selkirk's first day on the island of Juan Fernandez, illustrating the passage, "Thus he remained seated on his chest until darkness shut out every object from his sight." A sailor is seated on a sea-chest on the shingly shore, his head resting on his hand; his gaze is fixed across the sea, scanning the wide expanse with intense and eager look to desery anything which may give him hope. The picture is simple, and natural, and effective. Another picture presents a cottage interior, where a mother knits a coarse stocking and rocks a cradle with her foot at the same time. The third might be termed a new version of the *Belle Jardiniere*, except that the model, although a healthy rustic wench, is scarcely beautiful. The pictures are about 10 by 8, vignettted, and the photography very excellent.

REDUCING RESIDUES.—A correspondent says: "For the benefit of any who, like myself, have been unable to get sufficient heat to reduce the ashes from paper, &c., I may suggest that if they have an iron foundry near they may save themselves much unnecessary trouble by taking it there. I had 12 ounces of ashes, which was put in a clean crucible for melting brass, in what they termed the brass stove, from which I got 6½ ounces of metallic silver."

ANGLE OF VIEW.—We have received from "Tanno Glycerine," whose letter appeared in our last, a couple of prints referred to in the letter. They are both on 11 by 9 plates, but one is by Dallmeyer's triple No. 1, 8 inches equivalent focus, and the other by a caloscopic lens of 11½ inches focus. The amount of angle included by the former is enormously larger than by the latter, and the definition to the edges about the same; having been taken by waxed paper process, it is difficult to speak with the same certainty on the quality of the definition as if the negatives had been on collodion plates. It is somewhat singular that our correspondent, aided by a scientific friend, Mr. William Salkeld, C.E., had been trying, before seeing our note to his letter, the very method of measuring the angle we suggested, namely, the use of a protractor to measure the angle formed by the base line of the picture and the equivalent focus of the lens. They had ascertained the angle by calculation, and by taking a view and measuring the subject with a theodolite, each method confirming the other. We shall shortly have some further remarks on the subject.

To Correspondents.

W. D. B.—Excited albumenized paper may be used to test the non-actinic colour of glass, but unless it withstand the action of light entirely during very prolonged exposure, there is not much certainty obtained as to its suitability for the dark-room, as the difference between the sensibility of excited paper and a sensitive collodion film is almost incalculable. We generally use the spectroscope, which is a certain method of testing; but you may obtain certainty for yourself, if you desire, by placing the glass in contact with an excited collodion film and exposing it for a minute to the light, and then developing. If the film show no deposit whatever where it was protected by the glass, you may glaze your room with the same used without fear.

THOMAS JONES.—All the residues from your sink, cyanide, hypo, &c., may be treated with sulphide of potassium, and the silver recovered as a sulphide.

AN OLD PHOTOGRAPHER.—We believe that Mr. Solomon sells an apparatus for taking microscopic photographs.

M. A.—So far as we can speak with certainty, a good rule with ordinary tannin plates is to give them 6 or 8 times as long exposure as would be given to wet plates under the same circumstances. We do not know much of the constitution of Mawson's collodion, but we believe it to be slightly ironized. For the tannin process you would probably be safe in adding to it bromide of cadmium at the rate of a grain to the ounce. 2. The appearance of the image on a tannin plate after exposure and before development is often the result of over-exposure, but it is not necessarily the case; some qualities of collodion have a tendency to give it.

WAXY sympathies deeply with our correspondent "Cha-meal-ion's" troubles in connection with the lime toning bath. He says that his own "warm flesh tints" are disappearing, and that he is becoming pale and haggard; that he has absolutely discovered three grey hairs in his "rich black" locks; that he is, in short, becoming mealy himself, in trying to use the lime bath successfully. He wishes to know where Mr. Parkinson's paper, gold, and lime were obtained. So far as we know, the first was obtained from a provincial French town, the second from Paris, and the third from the nearest oil-shop to his atelier in Dieppe. See communications from Mr. Hughes and "Engineer," in the present number. We have within the last few days ourselves tried Parkinson's toning bath with perfect success. We shall probably have something to say on the subject in our next. The chloride of lime is such as we procure from the oil-shop. There is no need of any special preparation.

S. S. STARBUCK sends us a very good card picture as a specimen of his work as a negative operator of four months' experience. It is highly creditable to his skill and industry. The only improvement it needs is a trifle longer exposure of the negative.

J. E. WHITEHEAD.—The embossed paper referred to was simply an experimental sample prepared for Mr. Cooper, after the method described in our pages a few weeks before the allusion to which you refer. It has not been

prepared for sale as yet. We have not heard whether Mr. Cooper has made any progress with his experiments in that direction. Our correspondents must excuse us writing private letters on subjects which can be answered here. Our time would be more than fully occupied with letter-writing if we did so, and it is already considerably over-taxed.

PHOTO.—Nothing could be worse than the system you are advised to adopt. If you give the prints only two changes of water after coming from the hypo, and then leave them soaking all night, you leave them for hours in what is practically a weak hypo bath, than which nothing can be more destructive to the brilliancy and purity of the print, and possibly to its permanency. Washing for a couple of hours in six or eight changes of water, rapidly given at first, would be much more efficacious than such a system.

HICSON AND POOLE.—A saturated solution is easily made by taking care to have excess. The exact amount of either chloride of lime or carbonate soluble in water varies under different circumstances. The latter is scarcely soluble in pure water at all, but it is soluble when any carbonic acid is present, which in most waters it is in greater or less degree. We regret our inability to answer in private letters questions of this kind. Letters containing such questions are rarely even read until the appointed time for answering all in this column at one time.

CHURK.—Your best plan is to begin by neutralizing your bath with carbonate of soda, then sun for a few hours. Boiled rain water will, probably, contain some traces of organic matter, and sunning will precipitate it. Bear in mind, however, that the streaks to which you refer often arise with certain samples of collodion, and are entirely absent with another collodion in the same bath. 2. Nitric acid added to carbonate of soda will give nitrate of soda.

PETER GRIFFITHS.—The yellow stains are caused by some trace of hypo coming into contact with the prints before they are fixed, either from fingers or dishes. If the prints are washed in the same dishes, before fixing, which are used for washing them after fixing, traces of hypo sufficient to cause such stains will often hang about the dishes.

B. W. S.—The superficial fog you describe, which will brush off, and to which, if everything is not in perfectly good condition, there is often a tendency in hot weather, may often be prevented by decreasing the strength of the developer and using more acid in it. If this be insufficient the bath is at fault, and you had better neutralize and sun it. 2. The white stain you describe, probably arises from the drainings of the plate coming in contact with some foreign matter at the corners on which the plate rests.

C. E.—Rain water which has become brown from contact with organic matter may be rendered quite pure and suitable for washing dry plates by the addition of Condry's fluid. Chlorides will not be removed, however, from hard water by the same application. Distillation is the proper method of removing chlorides.

M. P.—Your negatives generally have been insufficiently exposed, and want a little more care to secure sharpness. No. 1 is much under-exposed, and altogether too thin to give good results. No. 2 is not sharp and is under-exposed. The varnish chilling is caused by using a spirit varnish without heat. The portions of the paper which you have marked with a cross have not come into contact with the silver solution, and the albumen has consequently been washed off in the subsequent operations. The brown stain in the middle of the print is from a defect in the paper caused by an irregular flow of the albumen. No. 3 is much under-exposed and a little fogged. No. 4 is the best; the streaks are apparently caused by an imperfect and uneven layer of collodion, possibly from the fault of the collodion, possibly from bad manipulation. Be more careful to get a perfect, even film without ridges or lines, and do not immerse the plate so quickly after coating. 2. You will find an article on collodion in our ALMANAC. 3. Always use glacial acetic acid, which is a definite article; its strength is indicated by its crystallizing at a temperature of 50° Fah. Beaufoy's acetic acid is an article of uncertain strength, generally containing about one third of real acid. The term "acetic acid No. 8" is a phrase used in America, and relates to the classification used there. 4. Some toning solutions may be used over and over—the acetate bath for instance. 5. A strong, hot solution of soda will cleanse a greasy bottle; rinse it well afterwards, before putting chemicals into it. 6. You may intensify after the plate is dry. Read the article on intensifying in our ALMANAC. 7. Plain collodion is uniodized. Pyroxylene is cotton which has been submitted to the action of acids, and rendered soluble for making collodion.

L. S. B.—In order to copy a picture the same size as the original, it must be placed at a distance from the lens equal to double the equivalent focus, and the camera must be extended to the same length. For instance, with your No. 1 B, which has an equivalent focus of between 5 and 6 inches, fix up the picture to be copied, and place the camera so that the lens is about 11 inches from the picture, and draw out the camera so that the ground glass is 10 or 11 inches from the lens. This done, a very little adjustment will give you a sharp image the size of the original. Use a small stop, and give sufficient exposure.

G. B. D.—The Photographic Exhibition in Paris is in a part of the Palais de l'Industrie, in the Champs Elysees. Several correspondents in our next.

Photographs Registered During the Past Week.

- MR. STEWART C. SMITH,** Witehurn Cottage, Campbelltown, |
Photograph.—Inauguration of the Albert Memorial on the 14th July at Rothesay.
- MR. JOHN D. MERCIER,** 38, Bold Street, Liverpool,
Photograph of General Sir J. L. Burgoyne, Bart., and his Aide-de-Camp, Captain the Hon. George Wrothesley.
- MR. THOMAS WILKINSON,** 121, Sargate Street, Dover,
Four Photographs of the Rev. Mr. Yate.
- MESSRS. W. AND D. DOWNEY,** 9, Eldon Square, Newcastle-on-Tyne,
Photographs of Professor Owen, Rt. Hon. Sir G. Grey, Rt. Hon. W. Gladstone, Daniel Maclisle, Thomas Milner Gibson, E. M. Ward, R.A., Sir Augustus Clifford.
- MR. A. S. WATSON,** 2, Regent Road, Great Yarmouth,
Photograph of Mr. Winter.
Photograph of C. Steele, Esq.
Photograph of H. Overman, Esq.

THE PHOTOGRAPHIC NEWS.

Vol. VII. No. 257. August 7, 1863.

CONTENTS.

	PAGE		PAGE
The Lime Toning Bath.....	373	A Photographic Gleance at Melrose Fountains, North Wales. By	
Photography at the Assizes.....	374	the Rev. J. C. Browne, M.A.	380
Scientific Gossip	376	Correspondence—Lime Toning—Ebonite Baths—A Case of Need	382
Dry Collodion—the Tannin Process. By G. De Vylder.....	377	Photographic Notes and Queries—Moisture and Actinism—New	
Macrophotography, or the Art of Taking Enlarged Pictures of		Transparent Medium, &c.	383
Photographs	378	Talk in the Studio.....	384
A Photographic National Portrait Gallery	380	To Correspondents.....	384
Doings of the Sunbeam	381	Photographs Registered during the past Week.....	384

THE LIME TONING BATH.

Nothing is more perplexing than the occasional discrepancies in evidence as to the specific results of some given formula. A adopts a certain toning process, and by patient experiment and watchful care he obtains perfect success. He finds great advantage from certain minor modifications, and after having, as he believes, obtained great certainty as to the most successful proportions and manipulations, he publishes for the benefit of his brethren in the art the results of his experience. B, who has been anxiously aiming at the tones described, at once tries the process; but he gets no better results than he did with the various baths he had tried before; some of the prints are pretty good; but the majority are flat, feeble and brown, or grey and mealy. The fact is, his negatives are thin and veiled, and can never yield such prints by any process; but he does not take this into account in his failures: indeed, he is probably scarcely conscious of it. C also tries the process, he has succeeded well hitherto, but is always anxious to improve. To his disgust every print is bleached, mealy and useless. He has followed the formula accurately; but his paper, his gold, his mode of printing are altogether different from those of A, and his results are also different, with a vengeance. D also tries the method. He is never much in the habit of weighing, he can measure pretty well with his eye; some of his conditions he knows are slightly different, but that is a thing too trivial to affect the matter much, he says. He fails entirely, and at once declares his conviction that A never succeeded with the process as he described it; but that some little important secret is held back. "They never do tell all they know, these fellows who profess to be so liberal!" he exclaims, and is satisfied that the process was described either entirely falsely, or with a reservation. Perhaps E, F, G, and the rest of the alphabet, succeed perfectly; some of them say so; but the majority are not much in the habit of talking, and still less of writing, and when they hear of the failures of the others they simply shrug their shoulders and say, "Oh, they never succeed in anything!"

We have recently called the attention of our readers afresh to the special characteristics of the toning bath of gold and lime, not as necessarily recommending it for all purposes, as, everything considered, we prefer the acetate bath for general use, but as giving certain qualities which many professional photographers are desirous of obtaining. We have published several formulæ, which we had either tried ourselves, or the results of which we had seen. We have had, since we published these formulæ, many communications on the subject, stating singularly discrepant results. There have been many failures, of which those detailed in the humorously pathetic letter of "Chameal-ion," which we recently published, may be taken as a sample. At the time we described Mr. Parkinson's formula

we had not tried it, but we had seen some hundreds of prints with a uniformity of rich black tones which we had not seen equalled before.

We have within the last week or two tried the formula several times, just as we stated it, and with the most satisfactory results. We first tried it in an hour after mixing. The result was, that on one sample of paper we obtained good prints with a trace of meanness, but on another sample from the same maker, the tone and quality were in all respects good. When the solution had been mixed six hours, we tried it on another sample of paper which had been sensitized and printed by a friend, who had brought the unfixed print to show us the quality of a certain negative. The paper was old and discoloured, but the toned print was perfect in tone and purity. In all the prints toned on the first day there was a little bleaching action, but trying it again, when four days old, we were surprised to meet with an action rarely secured in the toning bath; it very considerably increased the amount of contrast in the print, by toning the shadows a deep black, without in any appreciable degree bleaching them, or reducing their depth; and the sample of paper giving some degree of meanness the first day was now totally free from it. The chloride of gold was an ordinary sample, we believe, of French manufacture, very slightly acid. The chloride of lime had been kept in a well stoppered bottle for two or three months. We tried several samples of paper, which had been sent to us for trial at different times—they consisted of Lampray's enamelled paper, and his Sutton's patent paper; of Elliott's albumenized paper; of Hart's albumenized paper; and one or two others we don't remember.

What, then, are the special advantages of the lime toning bath, and what are the causes of the difficulties which occur in its use? Its advantages are chiefly to the portraitist who desires a pure black tone. Such a colour is rarely desirable for landscapes, and not always for portraiture. But the lime bath possesses this especial characteristic: when the deep shadows of the print toned in it are black the half-tones are of a warm neutral tint. With some toning baths it is difficult to get a black at all, if the print be pushed beyond a deep purple it becomes a greyish blue. With others, when the black tone is attained, the most delicate half-tones surrounding the high lights are gone altogether, and the remainder are grey and cold. The advantages of the lime bath are that it gives a very deep rich black to the shadows and a warm tint to the half-tones. The difficulties arise partly from the fact as explained by Mr. Hughes in our last, that it is very sensitive to the slightest change of conditions, and partly from the fact that the chloride of lime is a most inconstant and uncertain compound.

Chloride of lime is a somewhat unscientific name for a somewhat indefinite preparation. It is formed by passing chlorine gas through hydrate of lime. At first sight this would appear to be a simple mechanical mixture, the lime serving as a vehicle for carrying the chlorine; but an odour

is exhaled which is sensibly different from pure chlorine. The compound is generally regarded as consisting of hypochlorite of lime, chloride of calcium, free chlorine, and lime. Chloride of lime is said to be soluble in ten parts of water, which is equivalent to forty-eight grains to the ounce. It appears to be, however, more probably decomposed by water, as on adding this proportion to form a saturated solution a bulky precipitate is formed, which consists simply of hydrate of lime deprived of its chlorine. It will be seen from this that formulæ containing what is termed a saturated solution are apt to be misleading, as the manipulator is very apt to suppose he has obtained a saturated solution as soon as he sees a permanent precipitate, which will occur, however, long before he has obtained a really saturated solution. Again, chloride of lime is constantly changing in composition. In a vessel exposed in any degree to atmospheric action it is destroyed by the absorption of carbonic acid. Even when kept carefully stoppered a slow change is taking place, by which it is eventually converted into chlorate of lime and chloride of calcium.

If a really saturated solution of freshly made chloride of lime be made by dissolving about forty-eight grains in an ounce of water, a drachm will contain six grains; sufficient, and sometimes too much, for two or three grains of gold. Carbonate of lime is very sparingly soluble in ordinary water, which rarely dissolves more than half a grain to the ounce. In Parkinson's formula, it will be seen that if the chloride of lime have been freshly prepared, and great care have been used to secure a saturated solution nearly four grains would be used to each grain of gold. Such a proportion would probably, in many cases, especially when newly made, give excessive bleaching and mealiness. In many cases it is probable that the chloride of lime used is not freshly prepared, and possibly the solution is not really saturated, the presence of undissolved hydrate of lime misleading the manipulator in this respect. It is quite possible that the difference between an old and a new sample of chloride of lime, and the difference between real and apparent saturation may account for the varying experiences of some careful manipulators, and may account for success and failure. The remedy for failure in such a case is to adopt the suggestion of Mr. Hughes in our last: where bleaching and mealiness exist, decrease the amount of chloride of lime; when it is difficult to get a sufficiently black tone increase the amount. There is another point which may be worthy of notice, it is this:—Experimentalists, when trying a new bath, very naturally commence by immersing one or two prints. Now, if the quantity of solution be sufficient for many prints, and it contain free chlorine, it follows from the great affinity of that element for silver that the prints are at once attacked, all the free chlorine in the solution sufficient for a score of prints, it may be, is at liberty to act upon one or two, and considerable bleaching ensues, sometimes to the entire destruction of the print. Mr. Parkinson, in a recent letter, speaks of putting two hundred prints at once into a sufficient quantity of solution to tone them, and leaving them, with occasional turning over, for an hour, when the toning was completed. In trying this bath, then, it is probably desirable to use no more of the solution than is required for toning the prints immersed in it, so that there may not be the free chlorine of a larger quantity of solution to act upon a small number of prints.

Although the method of preparing the bath adopted by Mr. Parkinson is very convenient, and gives such excellent results in some hands, possibly more certainty may be obtained by weighing a definite proportion of chloride of lime than in using a saturated solution. A method we have repeatedly tried, and always with success, is to make a solution of chloride of gold one grain to the ounce, to this add excess of carbonate of lime, agitating well, and leaving the excess at the bottom of the bottle; to each ounce of this add from one to two grains of chloride of lime if freshly made, and from two to three grains if it have been kept some time. When required for use dilute the solution by the addition

of seven or eight ounces of water. This should be ready for use in a few hours, or keep for weeks.

We subjoin Herr Liesegang's modification of a similar formula, and his comments thereon, given some time ago in the *Photographisches Archiv*.

Take any chloride of gold in the market, dissolve it in rain water; then add to this solution common chalk in quantity of about one-sixth the weight of the chloride of gold dissolved; the chalk must be finely pulverized before it is mixed with the gold solution. The free acid of the gold combines with the lime and forms chloride of calcium, leaving probably a small quantity of carbonate of lime. After standing for an hour or two, shaking frequently in the meanwhile, the solution is filtered through broken glass and kept for use; it is a solution of the double chloride of gold and of calcium. If 15 grains of ordinary acid chloride of gold were used in the solution, then, to form the toning bath, take 45 ounces of rain water with which mix the solution of the double chloride; to this mixture add of a solution of chloride of lime until the whole assumes an alkaline reaction.

Of the value of the bath so made he speaks in the highest terms.

This description of gold bath, we are inclined to believe from experience, will last for a long time; at least, the qualities of a solution that has been prepared for more than a month have not undergone the slightest alteration; hence it may be argued that they will be retained much longer—a great advantage for amateurs, who only occasionally take a small quantity of the solution, dilute it with water, and thus can apply it.

This gold-toning bath for albumen paper is an important improvement. In the first place it is a clear and colourless solution, quite permanent, and immediately ready for use. Besides this, it does not bleach the prints, nor render them mealy like other gold baths. It is a solution of the double chloride of gold and of calcium, with a small addition of chloride of lime to neutralize the acid, and to give the solution a slightly alkaline reaction. The advantages of this solution over the gold bath, containing carbonate of soda, acetate of soda, and phosphate of soda, can easily be comprehended. All these baths are liable to change and precipitate the gold: the soda giving up the acid with which it is combined, enters into combination with the chlorine of the gold. But in our new bath the alkali is already in combination with chlorine, and thus neither withdraws chlorine from the gold salt nor precipitates the gold. When the excess of the alkaline salt is either a carbonate, acetate, or phosphate, the base gives up the weak acid with which it is in combination, and robs the chloride of gold of its chlorine; but when the excess of the alkaline salt is a chloride, such an effect is not produced, and the solution is perfect. In the preparation of this toning bath, it is necessary to be very careful to add neither too little nor too much of the chloride of calcium to the chloride of gold; a definite formula cannot be given, from the fact that commercial chloride of gold is very variable as to the quantity of free acid which it contains.

It is better to use the gold bath not too concentrated, the slower the process of toning, the more brilliant the picture remains. The bath loses strength with each print that is toned, but it remains clear and colourless, and can be strengthened by the addition of fresh solution. Before toning, the prints have to be thoroughly washed.

We have treated this subject at some length, because, having recommended the lime bath as possessing certain specific good qualities, we are anxious to give such information on the subject as will enable any of our readers to use it with satisfaction, and because for certain subjects requiring pure blacks and warm neutral tints, it gives better results than any bath we know.

PHOTOGRAPHY AT THE ASSIZES.

A CASE was heard on Tuesday last, before Mr. Baron Bramwell and a common jury, at Croydon Assizes, which will interest photographers, and points a moral as to the importance of having contracts relating to photography, as well as other matters, properly drawn and duly stamped.

The action stood on the case list as *Fry v. Birnstingl*, and was brought to recover the price of goods "sold and delivered," although a verdict was eventually obtained on a different issue. The defendant pleaded "never indebted." The facts of the case, as stated by the plaintiff's counsel, Mr. Serjeant Parry, assisted by Mr. J. C. Matthews, were as follows:—In the summer of 1861, Mr. Birnstingl, a dealer in fancy goods, in the course of some speculations in photography, entered into an arrangement with Mr. Samuel Fry, whose name is well known to our readers, to take fifty negatives, instantaneous sea views, to be paid for at the rate of a guinea each. They were intended for the printing of transparencies, and it was understood that Mr. Fry was to have the printing, and that his name should appear on each. A somewhat loosely worded contract or memorandum of agreement was drawn out, signed with the initials of each party to the bargain, who each received a copy of the document.

We may remark, in passing, that this agreement was not stamped, which was nearly fatal to all the proceedings. Mr. Fry's copy was unfortunately lost by having been placed in the hands of a person, to bring an action on the case, who turned out to be an unqualified practitioner, and from whom it was never recovered. The defendant's counsel put in his copy, and, pointing out that it was unstamped, submitted that the action must be based upon it, and that, being unstamped, it was invalid. If this had been ruled, we apprehend there would have been an end to the action, and whilst each party would have been fined ten pounds, the plaintiff would not only have lost his cause, but have been mulcted in all the costs besides. Mr. Fry's legal advisers were proceeding, however, for goods sold and delivered, apart from this contract, and the judge decided that a contract for goods sold and delivered did not need a stamp.

Amongst the clauses contained in the agreement was one to the effect that the negatives were subject to the approval of Mr. Birnstingl, and a sentence followed about the reading of which some doubt at first existed, as to whether it was "any part of the negatives not approved to be destroyed by Mr. Birnstingl," or, "any print of the negatives, not approved, to be destroyed by Mr. Birnstingl." It was eventually agreed in court that the latter was the real reading.

Mr. Fry proceeded to Ramsgate, and produced about seventy instantaneous negatives, which he delivered to Mr. Birnstingl, and then received from him the sum of twenty-five pounds on account, and a commission to proceed to the Continent to take other negatives.

This was done, but as Mr. Fry could not obtain any settlement of the first transaction, he never delivered any more negatives. He made application, however, from time to time to Mr. Birnstingl to select fifty negatives from those delivered, return the remainder, and pay the balance of the amount due. For some inexplicable cause, Mr. Birnstingl always refused to come to any settlement, alleging that he was quite at liberty to keep the negatives for twenty years, and then, if he did not approve of them, break them all. No settlement having been obtained, nor any negatives having been returned, this action was brought to recover forty-eight pounds ten shillings, the balance of the amount due for seventy negatives, at a guinea each. As we chanced to be at Ramsgate when Mr. Fry took the negatives in question, and saw many of them, we were called to depose to their general excellence and the moderation of the charge for them. Mr. Sydney Smyth, having been in Mr. Birnstingl's office when the negatives were delivered, was called to prove their delivery, and to express an opinion of their excellence as instantaneous negatives. He was cross-examined as to whether he had not, at the time, pronounced them bad, but denied that he expressed any opinion on the subject, alleging that as he was engaged on similar work at the time for Mr. Birnstingl, he did not feel called upon to give an opinion of the productions of others.

The defence was to the effect that the negatives were not satisfactory; that the twenty-five pound paid to Mr. Fry was not on account of the negatives delivered, which were declared to be bad at the time, but a payment in advance, to enable Mr. Fry to go to France to get others in their place; and that, as no others had been delivered, the faulty negatives were retained as some security for the repayment of the money advanced. In support of this there was no evidence but the defendant's statement, and the production of the receipt for the twenty-five pounds, which was in the form of an I.O.U., and stated that the money was in advance for negatives ordered.

Some of the negatives and some transparent positives were produced in court, and a good deal of amusing blundering occurred both at the bar and bench from the misapprehension and misuse of technical terms.

Mr. Serjeant Parry was interrupted in the course of an able closing speech for the plaintiff by the Judge, to point out that as the contract was for fifty negatives the action could not be brought for seventy; and as no especial fifty had been selected, the action for goods sold and delivered could not be sustained. To prevent a failure of justice, however, he would permit the plaintiff to amend. A special court was then prepared, bringing the action for damages for non-acceptance of the negatives.

Mr. Joyce, on behalf of the defendant, declining to plead to this new count, the learned Judge said the case became virtually an undefended action, and must go to the jury on the general plea on the record.

The learned Baron, in summing up, pointed out that it was absurd to suppose that the defendant had given Mr. Fry twenty-five pounds as an advance on a new commission, if he were convinced that the negatives already delivered were worthless, and suggested that, although the receipt was singularly worded, a person receiving a sum like twenty-five pounds was not always very particular as to the wording of the receipt he was called to sign. If the jury believed the plaintiff's statement, that the money was received on account of the negatives already delivered, and that no objection was taken to them at the time, the only question which remained for them was the amount of damages to be awarded for the non-acceptance or rejection of the negatives in a reasonable time, and for their detention until now. The learned judge endeavoured to gain some data as to the depreciation suffered in consequence of the decreased demand for instantaneous stereoscopic views. He asked our opinion, but we were unprepared to name at a moment's notice any definite sum. Other witnesses were unable to throw light on the question. The defendant's counsel incautiously said they would willingly take five shillings each for the negatives; upon which his lordship said, in that case the negatives had suffered a depreciation of sixteen shillings each, and after some further observations, left the matter to the jury.

After retiring for about three minutes, the jury returned with a verdict for the plaintiff, damages twenty-five guineas. By this verdict we understand that the negatives, not having been accepted, become again the property of Mr. Fry, together with the sum of twenty-five guineas, in addition to the amount already received, as damages for non-acceptance, or rejection, of the negatives delivered, within a reasonable time.

We ought here to add, that the attorney for the plaintiff in this action was Mr. W. W. King, an enthusiastic amateur photographer, and member of each of the three photographic societies in London.

In concluding, we cannot help urging upon photographers the importance in all cases of contract of having the terms clearly stated in writing, and of having the document stamped. These precautions are necessary in all agreements, but in the case of commercial contracts relating to an art like photography, which may eventually come for decision before persons entirely unacquainted with the details of the art, it becomes doubly imperative. We scarcely remember

an instance of an action relating to photographic dealings which might not have been avoided had a clearly stated and duly stamped agreement been made at the outset.

Scientific Gossip.

MOVEMENTS OF CAMPHOR ON WATER—NEW TEST FOR GREASE AND IMPURITIES.

WHEN small pieces of camphor are dropped on to the surface of a glass of water several curious phenomena may be observed. They immediately commence to rotate, and move about with remarkable energy, varying sometimes in rapidity, but usually conducting their gyrations in a strange and erratic manner. This is an experiment which most of our readers must have seen performed at some time or other. In order to obtain the best effects, some precautions are necessary: thus the camphor should be tolerably pure; the piece employed should be cut and separated from the larger lump with a perfectly clean instrument, and contact with the fingers should be scrupulously avoided. Moreover, the glass should be quite clean and the water pure. When these conditions are satisfied, the phenomena are really very striking, and well merit more attention than is generally devoted to such things. Several physicists have observed these curious motions of camphor; amongst others may be specially named Mr. Tomlinson and Mr. Lightfoot. The former gentleman has been attracted more to the physical phenomena involved in the movements, whilst Mr. Lightfoot has principally studied the chemistry of the subject. Each is of interest, but it is to some results recently found out in respect to the latter branch of inquiry that we desire at present to draw our readers' attention. If, instead of using a torn or cut fragment from a lump of camphor, one or two fine crystals are detached with a clean needle-point from the cork of a phial in which camphor is kept, and these are let fall on to clean water, they at once begin to move about with wonderfully increased rapidity, darting away in various directions, as if shot from some miniature engine of propulsion; or, as if endowed with life and a will of their own, they feared the searching eyes and magnifying lens of the observer in their endeavours to find a hiding-place; each crystal quivering and rocking on the water with an apparent high degree of indignation at its forced contact with the humid surface. This fury gradually diminishes, and a regular dance begins with the various additional particles that may be introduced to the company. They select partners, to some of which they will seem to cling with pertinacity, whilst others will either remain indifferent or, if attracted, will only stay a very short time in embrace, detaching and wandering again in search of more congenial floating associates. The explanation which Mr. Lightfoot gives of these movements is the emanation of a vapour from the volatile camphor. This vapour has a very low tension; the water upon which it floats being capable of dissolving and diffusing this vapour more readily in certain directions of the crystalline axes, thereby removes sufficient vapour pressure at those points for the opposite side to drive about (by recoil) the nicely suspended particle. Thus, if we place on water several well-defined hexagonal plates and prisms of camphor, the mutual attraction of the particles will be noticed to be stronger in the direction of the angles of the hexagon, accompanied by a decided preference for one of the axes, generally the longest in prismatic crystals. In certain positions two crystals of camphor will attract each other, whilst in other situations there is a mutual repulsion. It will sometimes happen that two crystals of camphor may be thrown on the water and not have any tendency to locomotion. When this is the case a continual trembling or vibration will be noticed in the crystal. When two such stationary vibrating crystals come in contact by attraction, immediately an eccentric, irregular change of place takes place, as if the force agitating each previous to the grouping produced a new resultant force in obedience to which the combined crystals move.

In our description of the method of separating and placing the camphor on the water, we laid some stress on the fact that everything should be quite clean, and that the fingers should not touch the camphor in any stage. The reason of this is obvious. If, whilst camphor is actively moving on water, the most minute particle only of certain greasy substances touch the water, instantaneously, as if by some magic shot, the camphor is deprived of all motion. The scene of previous activity is changed into the immobility of death. This curious property has been made use of by Mr. Lightfoot to detect grease in quantities so extremely minute as would appear almost fabulous. Thus, if we take a clean needle or pin, and only pass it through the hairs of the head, or cause it to touch the side of the nose or the surface of the forehead, and then insert the point of the needle just under the surface of the water, where camphor is rotating, it will instantly stop it; for camphor cannot be made to rotate on water containing the most infinitesimal portions of grease. Mr. Lightfoot has made use of this test in a most ingenious manner to distinguish between the two different methods of dyeing cloth with madder and with garancine. It is difficult and often impossible for calico-printers and merchants to distinguish between the two, and as the garancine dye is more fugitive than the first, and also of less intrinsic worth, it is sometimes substituted for it. There is, however, a slight difference in the process of manufacture—madder-dyed goods are, in one stage of the process, passed through a solution of soap to fix the colour, whilst in garancine-dyed goods the soap is replaced by hypochlorite of lime. By proceeding as follows, it is easy to distinguish between the two kinds of dye:—Let camphor rotate on water in any convenient glass vessel, as previously described, then immerse a small strip of the cloth to be tested. If the rotation stops, we infer the presence of soap, and conclude it to have been dyed with madder. But if, on plunging in the small piece of cloth, the rotation is not stopped, we then arrive at the conclusion that garancine was the dyeing material used. This plan of testing is more decisive in doubtful cases, if the pieces of cloth are, with as little handling as possible, boiled, each in a small glass beaker, and, when cooled, bits or crystals of camphor are dropped on the surface of each sample liquor.

Possibly our readers may never require to test pieces of cloth for a particular dye in the above manner; but they can frequently make use of the test with advantage in detecting the presence of grease in materials which more immediately concern them. What more necessary, for instance, than to have the cloths and leathers with which their glasses are cleaned perfectly free from grease? and how frequently are these important, though humble, adjuncts to the laboratory returned home by the laundress in a most unphotographic state of soapiness! A morsel of camphor in a glass of water will instantly show whether any cloth is fit to give the final polish to a glass plate, by its not arresting the movements, or whether it is dangerously greasy, as shown by its stopping the rotations. Again, it is not so commonly known as it ought to be, that distilled water frequently contains more than a trace of grease. Sometimes this can be recognised by the odour; but if this does not detect it, or if the photographer assumes that, because *distilled*, it must necessarily be pure, endless troubles and vexations may be entailed upon him, and fogging baths and stained plates will become the rule, instead of the exception. Before using the distilled water for any photographic purpose, it should always be tested by pouring a little into a wine glass, and then dropping a fragment of camphor on to the surface. The degree of purity of the liquid is at once shown by the energy of the movements. So delicate is this test, that the author has proved the presence of grease in water taken out of the sea about a mile from the pier at Southport (attributed to the sewage emptying itself near to the pier), whilst water taken out of the Irish Sea about sixty miles from Southport was perfectly free from any greasy matter whatever.

DRY COLLODION—THE TANNIN PROCESS.

BY G. DE VYLDER.

IN the month of April last MM. Teissère and Jacquemet communicated to the Photographic Society of Marseilles the Dry Collodion process they employ with so much success, and which, in the hands of amateur photographers much less skilful has led to the most remarkable results.

We are of opinion that we cannot too much draw attention of photographers to the importance of dry processes.

Wet collodion appears to have acquired the monopoly of producing portraits. But to dry collodion will belong, sooner or later, the monopoly of producing views. Now the vocation of the photographer is not to produce portraits exclusively : that in some respects is the commercial section of the art. The true mission of photography, in our opinion, essentially artistic, we might say civilizing, is the popularizing of the master-pieces of art, so that the idea of the beautiful may descend to the million, and plant the fruitful seed of the idea, of the good and the true, and the representation of scenes from nature, so that the knowledge of distant countries may be prohibited to the many, and that the majority may share the pleasures enjoyed every hour by those who travel wherever they list, with the sole object of seeing, learning, and knowing.

If it be true that wet collodion *can*, up to a certain point, suffice to the reproduction of pictures and engravings, it is indisputable that for taking views from nature, it is altogether insufficient, or rather, much too embarrassing on account of the baggage and apparatus required to work it in the field.

However ingenious and complete the portable laboratories invented may be, the necessity for developing on the spot immediately, the employment more or less simplified of developers, intensifiers, and fixing agents—will always prove serious obstacles to these apparatus becoming popular and generally adopted—which is also a matter of regret.

Let us, however, hasten to admit, so as not to offend the exclusive partizans of wet collodion, that this necessity for obtaining the first negative upon the spot, is sometimes an advantage in this sense, that if the negative has not the requisite qualities for giving good positives, enlarged or not, we can obtain another immediately without difficulty.

But this advantage over the dry process will no longer exist from the time that the latter becomes sufficiently certain, and perfect to furnish at once, a picture in the desired condition. It is from this point of view especially, that we call the attention of photographers to dry processes. He who succeeds in supplying a dry collodion more sensitive than any known at present, which will simplify manipulations without compromising the final result, will render a real service to the art.

In this respect, Major Russell has nearly solved the problem : by making known the properties of the preservative coating of tannin, he has, in great measure, caused the great difficulties of the albumen process to disappear, he has also simplified the process, and made an immense step in advance in the taking of photographic views.

But it must be admitted that in the pamphlet in which Major Russell describes his process, the explanations he gives are not calculated to encourage experiments. He who for the first time undertakes the reading of the "Tannin Process" is, in some measure, intimidated by the minute details, by the precaution to be taken, the accidents to which he is liable, and the causes of failure, of which the author is not sparing. It demands no small stock of courage, to proceed, without deviation, to the end of this labyrinth of details, and a certain amount of perspicacity to separate what constitutes the essence of the process, from the material conditions by which to accomplish its execution. To cause this process to be adopted and become popular, only its peculiar characteristics should be given, and the leading features of its manipulations, and leave to experience the care of regulating the precautions of detail.

These remarks of course apply only to the form given to the pamphlet, and not to the process itself, for which we have perfect sympathy. We only think, contrary to the opinion of M. Girard, that in the explanation of the process, useless details are sometimes misplaced ; those to whom photographic treatises are already familiar, more or less, very well know the infinite precaution which must be taken at every moment, and moreover that a failure in this, as in all other things, teaches more than any amount of written explanation.

We repeat that in rendering sincere homage to the valuable discovery of Major Russell, and in acknowledging the services it is called to render, we admit that there is a necessity for explaining it in the clearest manner, and in the most inviting also.

It is with this object in view that we have solicited and obtained permission to give in our course of instruction at the School of Industry, and to publish in the *Bulletin Belge de la Photographie*, the tannin process which M. Jacquemet has wished us to communicate the explanation is ; given with such simplicity and clearness as to dispel from the first all idea of failure. Candidly, we cannot too much exhort amateurs to try this process ; we are convinced that they will succeed at the first trial.

In our experiments we have employed the autopolygraph invented by M. Vidal, an apparatus less known than it deserves to be, but which is undoubtedly destined to become very popular. It is very simple in its working ; and the bulk is reduced to the smallest compass, it presents therefore all the advantages we look for in an apparatus with which we have to traverse plains, or climb mountains. It may be objected that the negatives it yields are too small $3\frac{1}{2}$ inches by 4 inches. But these are the dimensions of stereoscopic pictures so very popular at the present day, and if they can afterwards be enlarged by a process as simple and ingenious as that indicated by M. Testelin, in a pamphlet he published some years ago, it will be possible for any one possessing a whole plate apparatus to obtain with the greatest facility positives or negatives enlarged from the negative furnished by the autopolygraph.

We now arrive at the explanation of MM. Teissère and Jacquemet's process, which although, it differs but slightly from that of Major Russell, deserves, nevertheless, to be regarded as a special process.

1. *Collodion*. Every collodion which yields good results in the wet process may be employed in this. Remarking that it must contain at least 1 per cent of iodide and 1-3rd of bromide. We generally make use of the collodion described by M. Van Monckhoven in the last edition of his "*Traité de Photographie*," lightly increasing however, the quantity of iodides and bromides. The following is the formula of this collodion :—

Ether	60 drachms.
Alcohol... ..	40 "
Pyroxyline	1 drachm
Iodide of cadmium	0.75 drachms
Iodide of ammonium	0.50 "
Bromide of ammonium	0.40 "

MM. Jacquemet and Teissère have undertaken a series of experiments concerning the employment of a special collodion, more sensitive than ordinary collodion. But as these experiments are not yet completed, and as it is also but just that to the inventors alone should belong the honour of initiating the public, we abstain from mentioning even the principle upon which these experiments are based.

The plates are not gelatined. This is a step in advance, for the application of gelatine is a delicate and difficult operation.

The collodion is therefore directly applied upon a well-cleaned plate ; taking care to leave no corners. To cover the plate easily, we hold the plate with a tuft of cotton slightly moistened with distilled water.

2. *Sensitizing.* The silver bath to sensitize the collodion plate is composed as follows:—

Distilled water	100 parts
Crystallized nitrate of silver	...	8 "	
Glacial acetic acid	...	2 "	

The operation is conducted as follows: the sensitizing bath may contain two plates at once, a light border of gutta-percha separating them, so that one plate cannot slide upon the other. While we are collodioning a second plate, the first is sensitized, and when the second is put into the silver bath, withdrawing the first, which is immediately put into the first washing bath, and so with the rest. The first operation is thus performed rapidly and in good condition.

3. *The Washings.* As the plates are withdrawn from the sensitizing bath, they are placed in the first bath of filtered distilled water, where they must remain until the greasiness disappears. When the twenty plates of the autopolygraph are collected in this bath, they are passed successively, one by one, into two other baths of ordinary filtered water, and, lastly, in a fourth bath of distilled water, also filtered. When all the plates have been collected in this last bath, and we are about to apply the preservative solution, a light stream of distilled water is poured over each plate, in order to remove the last impurities that may still adhere.

For these washings we employ rectangular zinc dishes, covered internally with a coating that cannot be attacked (manufactured by M. Deltenre). The middle of the dish is occupied with a raised partition, so that it forms a sort of continuous channel upon the edges of which the twenty plates rest. The dishes are 24 inches long by 8 inches wide.

4. *Application of the Preservative.*—The tannin solution is formed of

Distilled water	100 parts
Tannin	...	3 "	
Alcohol	...	5 "	

To prepare it we put the tannin into the water and it is generally very quickly dissolved; then it is filtered several times, three or four at least, and, lastly, some clear alcohol is introduced into the liquid. The object of the latter is to make the liquid penetrate the collodion film more readily; it also assists in making the solution keep longer without decomposition. It should be noted that the alcohol must not be added until the solution of tannin is filtered, for the alcohol dissolves certain resinous substances always found mixed with tannin which are insoluble in water.

We then take two lipped glasses, of very different forms, and numbered, so as not to confound them with each other, and pour into each a certain quantity of the solution of tannin.

After the first bath, withdrawn from the last washing bath, and rinsed with a stream of distilled water and drained, we pour upon it several times the contents of the glass No. 1 until the liquid has well penetrated the film, that is to say, until it has covered all parts of the plate equally; next, this tannin application being complete, the plate is drained, and then the contents of glass No. 2 at once, and the excess is poured off into glass No. 1.

We then put the plate to dry, collodion side downwards, resting by one corner on a piece of blotting-paper. But according to the recent experiments of MM. Teissère and Jacquemet, the sensitiveness of the plate is greatly increased if after having poured on the tannin the plate is washed in a stream of distilled water, so as to free it from the excess of tannin. It is important not to touch the collodion or the silver bath with the fingers more or less soiled with tannin; to avoid any accident, it is well to first sensitize all the plates, before proceeding to the application of the tannin.

After drying for seven or eight hours, under the ordinary conditions of heat and moisture, the plates are ready for use. They are then placed in the upper chamber of the autopolygraph, or in a grooved box, hermetically closed. The sensitiveness of these plates continues a very long time, as much as two or three months, but they eventually become mouldy.

5. *Exposure.* The autopolygraph we employ is furnished with a simple quarter-plate objective; with the smallest diaphragm the exposure will be—

For a lens with 4 inches focus,	1 to 1½ minute.
Do. do. 5½ do.	2 to 2½ minutes.
Do. do. 7½ do.	3 to 3½ do.

6. *Development.* It is important to delay the development as little as possible, for the plates quickly lose the faculty of retaining the image. Here, if we do not deceive ourselves, is the starting point of a theory explanatory of the formation of photographic images, the principle of which was first announced by M. Vidal.

Before commencing the development, the edges of the plate must be coated, by means of a small pencil, with a very dense varnish, composed, for example, of—alcohol, 100 parts, shellac, 20 parts; two coats must be applied. After drying, each plate is immersed for a few moments in water, and afterwards uniformly moistened with the sensitizing solution. The plate is next immersed in a flat dish containing a sufficient quantity of the following developing solution:—

Distilled water	200 parts.
Pyrogallic acid	1 part.
Glacial acetic acid	10 parts.

It must be continually shaken to avoid deposits.

The most delicate part of the process now begins, at least under certain circumstances. The development may exhibit three distinct characters:—

1st. The proof comes out well; the whites well preserved, and all the details distinct and clear; we have then only to add gradually a few drops of a weak solution of nitrate of silver, so that the blacks may assume the intensity required in a good negative.

2nd. The picture comes out rapidly, with a tendency to fog; it has been exposed too long. We then add a few drops of acetic acid, without nitrate, to check the development. Towards the end, add, if necessary, a little silver, to bring the picture to the desired tone.

3rd. The picture comes out slowly; the large lights only are distinct; there is no detail; the exposure has been insufficient. Then add to the liquid in the dish two or three drops of a concentrated alcoholic solution of pyrogallic acid (for example, one drachm to ten of alcohol, which serves very well for the preparation of the strengthening solution in the wet collodion process); add, also, one or two drops of a weak solution of silver, and allow it to act. If the addition is insufficient, increase the dose until the details come out, then strengthen, if necessary, by adding acetic acid and silver.

During this operation it may happen that the liquid becomes muddy; it must then be quickly rejected, and replaced by a fresh quantity of the original developer.

At the conclusion of these manipulations, longer and more difficult to describe than perform, the plate is carefully washed, and fixed as usual, but with hyposulphite of soda. After washing, a coating of gum-arabic solution is applied, and when the plate is quite dry, it is varnished. The negative is now finished.

As the reader may now judge, the process is far from being difficult or complicated; and success is pretty certain. And we again urge amateurs to try it. If they carefully follow the directions here given, it is quite certain that their efforts will be successful.—*Bulletin Belge de la Photographie.*

MACROPHOTOGRAPHY, OR THE ART OF TAKING ENLARGED PICTURES OF PHOTOGRAPHS.*

THE NEGATIVE FOR ENLARGEMENT.

THE size of the negative will have to depend on the diameter of the condenser; if this be nine inches, a one-sixth plate will be large enough, the object being to get the negative as

* From *Humphrey's Journal.*

near the apex of the cone of concentrated light as possible, and in such a position as to be totally covered by the conc.

THE QUALITY OF THE NEGATIVE.

The negative suitable for the solar camera must be very bright, well-defined, and quite clear. The glass must be thin, perfectly flat, and homogeneous. The negative effect need not—in fact, must not—be carried on to the same extent as for positive printing; it is but a trifle in advance of the ambrotype. If there should happen to be the slightest quantity of fogging—that is, reduction on the transparent parts—it will be necessary either to take another negative, or to clear off the fogging. This is effected by flowing the plate with a dilute solution of iodine in iodide of potassium until the picture turns slightly cream-coloured; the plate is washed, and then flowed with a solution of cyanide of potassium, which dissolves the newly-formed iodide of silver, and thus clarifies the negative. If satisfactory, wash and dry, but apply no varnish.

Previous to fixing the negative in the plate-holder, adjust the lens to its right position, so as to bring the *focus of the actinic rays* immediately on the optical centre of the last or front lens of the combination. It is by this means alone that the best enlarged picture can be obtained.

HOW TO FIND THE POINT WITH ACCURACY WHERE THE LENS IS TO BE PLACED.

Ascertain the focal length of the condenser by finding the distance of its burning point from the glass; then, when the tube is screwed out to the extent of its play, measure the distance from the face-plate, in which the tube is fastened, to the front lens; subtract this distance from the focal length of the condenser: the difference will give the distance of the condenser to the outside of the camera nearly, or to the part upon which the face-plate of the tube is to be screwed.

More accurately the same result can be obtained by interposing the tube in the condensed light, and by moving it backwards and forwards until the focal or burning point is just on the outside of the front lens; let an assistant measure this distance from the outside of the camera, and at this distance fix the tube permanently. Whilst doing this the greatest care is required to make the axis of the condenser coincide exactly with the axis of the tube.

This is the first rude adjustment. The second adjustment consists in bringing the actinic focus so as to coincide with the optic centre of the front lens. Screw back the sliding part of the tube, and turn on the sun; the luminous focus will be quite visible in the dark space behind the camera. Now insert a piece of deep violet-coloured glass between the condenser and the objective, so as to intercept all the colours of the luminous cone excepting the violet, and ascertain where the violet cone comes to a focus. Screw the tube out until this focus is just in front of the anterior glass; then, knowing the thickness of the front lens, advance the tube until the blue focus is in the middle of the front lens. This will be the *final and permanent adjustment* of the tube in reference to the condenser. Mark this position by a line on the brass-work, in order that the tube can be adjusted at a moment's notice when required to be used.

The negative-holder is movable by means of a screw, so that it can be brought into focus upon any screen on the other side of the tube. Whenever this operation of focussing is to be performed, insert the violet-coloured glass so as to focus in reference to actinism, and not to luminosity. By this means the luminous picture on the screen (that is, when the violet-coloured glass is removed) may not be quite sharp, but the printed picture on the paper will be sharp and beautifully defined.

The same mode of proceeding may be followed with the ordinary camera, where there is any doubt of the correction of the tube for actinism. Place in front of the tube a plate of violet-coloured glass every time you focus.

As soon as the negative is in its place, and accurately focussed actinically, fix the prepared paper on the screen in

its place. In order to preserve the paper perfectly flat and smooth, sponge the back with a wet sponge, and after it has thoroughly expanded, and lies uniform and without undulations, go round the edge to the amount of half an inch, on the same surface that has been sponged, with a thick solution of gum arabic; attach the paper so prepared to an even plate of glass or hard drawing board of somewhat smaller dimensions than the paper, and allow it to dry. When dry, all the corrugations and undulations will have disappeared; the paper will be smooth and flat, and ready to receive the image, supposing naturally it has been already sensitized in the silver bath. If this operation has been omitted or neglected, the silver solution can be very expeditiously poured upon the surface and spread with a pad or tuft of cotton wool until the film is uniform. The excess of silver is then removed, and the plate is reared on one corner over a wine-glass to receive the drippings.

When dry, it is placed in the focus of the negative, and the sun is turned on. By means of the two screws on the solar camera, the sun's light is maintained in its position during the whole operation. Printing on albumenized paper by the solar camera is a tedious operation, requiring sometimes several hours before it is complete, and sometimes even a day or two, by reason of the cloudiness of the sky.

Where this sort of printing is practicable, as is the case generally in our own country, the results are the best. Printing by development, however, is more reliable, because it is altogether independent of the condition of the sky, whether cloudy or cloudless. Several processes by development may be found in text-books devoted to the subject. I will insert in this place the one practised by Blanquart-Evrard, whose prints have been so much admired.

BROMO-IODIZING BATH FOR PAPER.

Water	12 ounces.
Gelatine	1 drachm.
Iodide of potassium	1 drachm.
Bromide of potassium	15 grains.

Immerse the papers in this bath, as many at a time as it will contain, and keep them there for two or three hours. The bath can be used over and over again until exhausted. The papers are then taken out and hung up to dry. As soon as they are dry, they may be preserved in a portfolio for use.

Previous to being sensitized they are exposed for a quarter of an hour to the vapour of hydrochloric acid. This operation is easily effected by fixing the papers along the sides and under the lid of a large nearly air-tight box, by means of varnished pins. At the bottom of the box place a saucer containing a handful of salt, an ounce or two of sulphuric acid, and half as much boiling water. Vapours of hydrochloric acid will be generated in abundance, and will thus saturate the paper.

SENSITIZING BATH.

Nitrate of silver	1 ounce.
Distilled water	14 ounces.
Nitric acid to give it an acid reaction.	

Let the papers float in this solution for ten minutes. By decomposition they will now contain the iodide, the bromide, and chloride of silver. After sensitization they are allowed to drain, and then dried either by pressure between folds of bibulous paper or by suspension in the dark room.

The exposure required will vary from a couple of seconds to half a minute beneath a negative, and longer than this on the screen of the solar camera. When the image is just visible the printing has been carried on long enough.

DEVELOPMENT.

The picture is brought out by immersing it in ordinary gallic acid bath, at a temperature of 80° Fahrenheit, and by keeping them there a quarter of an hour or more as circumstances require. The bath or dish must be large enough for

many pictures at a time; these are kept in motion all the while. They assume a disagreeable colour, and become covered with spots, which are removed by the operations afterwards. As soon as the depth of the shade is sufficiently intense, the prints are taken out, laid one by one on a glass plate, and sponged on both sides, and then immersed in a bath of hyposulphite of soda for five minutes, in which they are toned.

Hyposulphite of soda 1 ounce.
Rain water 20 ounces.

After this they are removed direct into a second bath of hyposulphite of soda of the same strength, and are allowed to remain for twenty minutes, in which they are completely fixed.

The prints are then carefully washed in several waters, and finally immersed in a bath of dilute hydrochloric acid, which removed a yellow deposit and the spots above mentioned. A second washing completes the operation, with the exception of drying and exposing to the action of light for several weeks, which improves the reddish tone by changing it gradually into purple.

These prints will keep for an indefinite time, although toned with sulphur.

A PHOTOGRAPHIC NATIONAL PORTRAIT GALLERY.

PHOTOGRAPHY is daily extending its sphere of usefulness. A new project for its grasp has just been put forth. It is this: that the resources of photography should be applied to the systematic preservation of the likenesses of distinguished individuals. It is true that in the present state of the art prints from the negative plates cannot be depended upon as lasting records, but it is equally true that the negative plates themselves are as lasting as the material (glass) upon which they are taken. Mr. MacLachlan, of Manchester, proposes that the negative plates of great men should be secured and placed in a museum for safe keeping, properly authenticated, attested, and registered by the mayor or other authority of the place where they were taken; and, to provide against accidents, he suggests that in every instance three plates of the same individual should be deposited. This can easily be done, as the original one can be always reproduced at pleasure. He proposes "securing three plates, in order that one may be kept sacredly within the institution, and the other two be lent at the discretion of the authorities in charge,—for instance, to any author of eminence for book illustration: and by that means the memories and images of those who have been great and have passed away would be transmitted faithfully to all posterity. In almost every instance there would be several portraits of the same individual in different museums in the country, affording a still greater security for their permanent preservation. All local celebrities might be taken in their own towns and deposited in the museums of their respective localities; and should a time arrive when their genius became acknowledged by the world, then they might claim a place in our Great National Museum." What would we not now give for such a faithful record of the features of Shakspeare, and many others? The space required for the due storage of many thousands of such plates, carefully numbered and indexed and ready of access, would be very small. A cubic foot of space would hold several thousands. The cost of procuring such plates would be very trifling. Indeed, in a large majority of instances, the photographers would be willing to deposit negatives in return for the privilege of having sittings from distinguished individuals, whose portraits they would thus be enabled to sell for their own advantage. Hereafter, when the art of burning in the likeness on glass after the manner of enamels (some very beautiful specimens of which were exhibited in the late International Exhibition) is brought to perfection, we may dispense with the negatives, and a collection of miniatures on enamel may be made, which will indeed form a real national portrait-gallery.—*Athenæum*.

A PHOTOGRAPHIC GLANCE AT MELROSE FOUNTAINS, NORTH WALES, &c.

BY THE REV. J. C. BROWNE, M.A., EMMANUEL COLLEGE, CAMBRIDGE.

THE time having arrived when our brethren are starting hither and thither, with camera on shoulder—more, we trust, for the sake of enlightening the mind, and adding to their stock of health and art, than simply to bring back mementoes of places visited—I will give you a short account of my last summer's tour.

I started from Edinburgh about the middle of July, under the most unfavourable auspices in point of weather, and in an hour and a half or so found myself comfortably located at Melrose. Hard as it rained I could not refrain from going to have a peep at the dear old Abbey, just to see that it really was there, in case I might find it levelled to the ground in the morning; for Admiral Fitzroy had shaken my previous faith in him as the "photographer's friend," by ordering the cone and drum to be hoisted at Leith Harbour.

Morning came, and with it a bright, clear sun and a fresh breeze, and I saw that all was right for my work that day. Breakfast over, I sallied forth, paid my shilling admittance to the Abbey, and began at the lovely east window, towards the sacred mullions of which—clearly revered by the devouring chisel of Time—I planted my Horne and Thornthwaite's double lensed stereoscopic camera. The wind, however, began to rise to such an enormous extent that I was obliged to place some of the scattered fragments of stones lying about the graveyard upon the camera to steady it, and withal to stand back to the gale with an open umbrella. It was hard work; but, nevertheless, I exposed four tannin plates, and all but one turned out good—the delinquent having clearly had a good shaking in the wind. Next day was as bad; so I amused myself with standing above my knees half the day in the Tweed, and was rewarded with a few trout. The day following was more after my sort, and I succeeded in getting a series of views from east round by south to south west, and a couple of interiors, and bade the place "good bye."

On Sunday, after church, I walked to Abbotsford to see the place; but being too far to take another journey with my camera over there, the next day, Monday, saw me at Carlisle. Thence proceeding to Windermere, I stayed one night there, and the following at Ambleside; but so little presented itself in a stereoscopic point of view, that I made my way through Leeds to Ripon, where I stayed at the "Angel" for four days.

Through the kindness of Captain Smith I obtained a key to Pountains Abbey, and was there every day and all day, insomuch that I never even had a peep at Ripon Cathedral. During my visit there I scarcely once saw the sun, and nearly all my plates were exposed in drizzling rain; however, tannin was my friend, and I managed to get some third class pictures.

Off to Chester, through Manchester. Finding myself in a cathedral city, the temptation of choral services overcame me, and I postponed setting foot in Wales until the Monday morning. Starting early, I reached our rendezvous—the Castle Hotel, at Conway—where I found two old college friends, who, tired of waiting for my train, and afraid of missing the coach, were already hard at work at a nine o'clock breakfast. The coach drew up. We had not previously booked our places, and consequently were compelled to lose the scenery of the Vale of Llanrwst by sitting for some hours in the miserable inside. Doubtless it was a novel sight for our Welsh "chaw-bacons;" but legs six feet long would not wholly go inside, and, not daring to trust them amongst the rest of the luggage, we showed about three feet of ash out of each window.

Arriving at Bettws-y-Coed, we feared we were "done," the principal inn being full to a bed, and people already on foot

in search of lodgings, but none to be got. However, by some good luck, we managed to get to the other hotel—the Waterloo—just as two bedrooms were being vacated, and we booked ourselves for a week or so. Of all the places we visited we preferred this, their being no fewer than a thousand and one pictures to be taken within a radius of a couple of miles.

The chief places for photographers to visit, and such as they must not omit taking, are—the old ivy-grown bridge at the Toll-gate over the Llugwy, views both up and down; the Miner's Bridge, higher up, towards Capel Curig; and the Swallow Water Falls, higher still. The Miner's Glen is a lovely spot, and Mr. Hornby got some capital $7\frac{1}{2} \times 4\frac{3}{4}$ collodio-albumen pictures of it.

Turning out of the Waterloo to the right hand, a bridge spans the river—a single arch of iron—and through the whole length of the arch is the following inscription:—"This arch was constructed the same year the battle of Waterloo was fought." Of this bridge, though a modern erection, a very artistic picture can be got about thirty yards from it, towards the Lledr Valley on the Bettws-y-Coed side.

Crossing the bridge take the first turning to the right, and, just before you arrive at a stone bridge, one of Nature's real nooks presents itself, on the left-hand side of the road, in the shape of a fountain, about six feet, cubed, overgrown with briars, brambles, &c.; but it wanted something to fill up the interior, and so I planted some ferns, and obtained a very good picture in twenty-two minutes on a dull day.

Instead of crossing the bridge, which would take you to the Lledr Valley, I think the road straight on more interesting; and some very good rocky pieces can be got by the side of the gorge through which the Conway flows. The celebrated Conway Falls are a little higher.

From Bettws-y-Coed we proceeded through Capel Curig to Beddgelert—a lovely spot, near which is the grand Pass of Aberglaslyn, with its renowned Pont. A whole day may be profitably spent in its vicinity. The windings of the river are very pretty; also some good thatch-grown cottages and a rustic bridge on the right-hand side a few yards up from the road, entering by a sort of stone-grinding mill.

From Beddgelert we made the ascent of Snowdon without a guide, our party consisting of Mr. D. Hornby, his brother (Mr. T. Hornby), and a gentleman from Preston (Mr. W. Perfect). We ascended in a fog; but Nimbus permitted us a few bright moments at the summit, and we got some first-rate stereographs of the Cairn and public houses on the top. Descending we obtained some glorious sunset views of Anglesea, the Tubular Bridge, and down along the eastern coast of the country.

Leaving Bettws-y-Coed we took a trap to Carnarvon, and just caught the train to Menai Bridge. The Nant Mill must not be omitted on the road to Carnarvon. It was very wet during our stay at Menai Bridge, but we got some very fair pictures of the Suspension and Tubular Bridges. Passing Bangor we returned to Conway, thence to Llandudno and Great Ormeshead, and so we found ourselves once more at Chester.

I have omitted to mention that one day at Beddgelert we walked round by the Gwynant Valley, through the Pass of Llanberis, to the town, where we took views of the famous falls and slate quarries.

We proceeded to Manchester, and then shot straight across England, where we visited Mr. Thomas Hornby for a fortnight; thence to Scarborough, where we also obtained some very fair pictures—one of Mr. Hornby's $7\frac{1}{2} \times 4\frac{3}{4}$, of the Swiss Cottage in the Cliff Company's grounds, being only equalled by a magnificent negative afterwards taken at York of the Galilee door of the Minster.

At York we parted company, hoping at no distant period to revisit North Wales and its bold scenery.

The account of a successful tour ought certainly to have appended the working of the process. I used some collodion made by Lennie and Co., opticians, &c., Princes-street, Edinburgh. No previous coating of gelatine. Sensitised is

an ordinary 35-grain bath, nearly neutral; thoroughly washed the plate, first in distilled water, then in salt water, about one grain to the ounce, and then thoroughly under a tap. I then swilled the plate with distilled water, and poured on and off once or twice some of the following solution:—

Tannic acid	15 grains
Crystallized coffee sugar	15 "
Distilled water	1 ounce.

Filter when dissolved.

When the plates are covered and drained set up to dry.

To develop I placed round the plate about one-eighth of an inch rim of benzole and white wax (saturated) which dries in two or three minutes. Then covering the plate with pyrogallic acid, three grains to the ounce, I afterwards added one drop of—

Nitrate of silver	10 grains
Citric acid	10 "
Distilled water	1 ounce,

until all detail was out, then added this silver solution until sufficiently intense, and fixed with cyanide. The film must slowly dry, otherwise, in some few cases, I found it split up into ribbons.

DOINGS OF THE SUNBEAM.*

WE have learned many curious facts from photographic portraits which we were slow to learn from faces. One is the great number of aspects belonging to each countenance with which we are familiar. Sometimes, in looking at a portrait, it seems to us that this is just the face we know, and that it is always thus. But again another view shows us a wholly different aspect, and yet as absolutely characteristic as the first; and a third and a fourth convince us that our friend was not one, but many in outward appearance, as in the mental and emotional shapes by which his inner nature made itself known to us.

Another point which must have struck everybody who has studied photographic portraits is the family likeness that shows itself throughout a whole wide connection. We notice it more readily than in life, from the fact that we bring many of these family portraits together, and study them more at our ease. There is something in the face that corresponds to *tone* in the voice,—recognizable, not capable of description; and this kind of resemblance in the faces of kindred we may observe, though the features are unlike. But the features themselves are wonderfully tenacious of their old patterns. The Prince of Wales is getting to look like George III. We noticed it when he was in this country; we see it more plainly in his recent photographs. Governor Endicott's features have come straight down to some of his descendants in the present day. There is a dimpled chin which runs through one family connection we have studied, and a certain form of lip which belongs to another. As our *cheval de bataille* stands ready saddled and bridled for us just now, we must indulge ourselves in mounting him for a brief excursion. This is a story we have told so often that we should begin to doubt it but for the fact that we have before us the written statement of the person who was its subject. His professor, who did not know his name or anything about him, stopped him one day after lecture, and asked him if he was not a relation of Mr. —, a person of some note in Essex County. Not that he had ever heard of. The professor thought he must be,—would he inquire? Two or three days afterwards, having made inquiries at his home in Middlesex County, he reported that an elder member of the family informed him that Mr. —'s great-grandfather, on his mother's side, and his own great-grandfather, on his father's side, were own cousins. The whole class of facts, of which this seems to us too singular an instance to be lost, is forcing itself into notice, with new strength of evidence, through the galleries of photographic family-portraits which are making everywhere.

In the course of a certain number of years there will have been developed some new physiognomical results, which will prove of extreme interest to the physiologist and the moralist. They will take time; for, to bring some of them out fully, a generation must be followed from its cradle to its grave.

* Continued from page 369.

The first is a precise study of the effects of age upon the features. Many series of portraits taken at short intervals through life, studied carefully side by side, will probably show to some acute observer that Nature is very exact in the tallies that mark the years of human life.

The second is to result from a course of investigations which we would rather indicate than follow out; for, if the student of it did not fear the fate of Phalaris,—that he should find himself condemned as unlife-worthy upon the basis of his own observations,—he would very certainly become the object of eternal hatred to the proprietors of all the semi-organizations which he felt obliged to condemn. It consists in the study of the laws of physical degeneration,—the stages and manifestations of the process by which Nature dismantles the complete and typical human organism, until it becomes too bad for her own sufferance, and she kills it off before the advent of the reproductive period, that it may not permanently depress her average of vital force by taking part in the life of the race. There are many signs that fall far short of the marks of cretinism,—yet just as plain as that is to the *visus eruditus*,—which one meets every hour of the day in every circle of society. Many of these are partial arrests of development. We do not care to mention all which we think may be recognized, but there is one which we need not hesitate to speak of from the fact that it is so exceedingly common.

The vertical part of the lower jaw is short, and the angle of the jaw is obtuse, in infancy. When the physical development is complete, the lower jaw, which, as the active partner in the business of mastication, must be developed in proportion to the vigour of the nutritive apparatus, comes down by a rapid growth which gives the straight-cut posterior line and the bold right angle so familiar to us in the portraits of pugilists, exaggerated by the caricaturists in their portraits of fighting men, and noticeable in well-developed persons of all classes. But in imperfectly grown adults the jaw retains the infantile character,—the short vertical portion necessarily implying the obtuse angle. The upper jaw at the same time fails to expand laterally; in vigorous organisms it spreads out boldly, and the teeth stand square and with space enough; whereas in sub-vitalized persons it remains narrow, as in the child, so that the large front teeth are crowded, or slanted forward, or thrown out of line. This want of lateral expansion is frequently seen in the jaws, upper and lower, of the American, and has been considered a common cause of caries of the teeth.

A third series of results will relate to the effect of character in moulding the features. Go through a "rogues' gallery" and observe what the faces of the most hardened villains have in common. All these villainous looks have been shaped out of the unmeaning lineaments of infancy. The police officers know well enough the expression of habitual crime. Now, if all this series of faces had been carefully studied in photographs from the days of innocence to those of confirmed guilt, there is no doubt that a keen eye might recognize, we will not say the first evil volition in the change it wrought upon the face, nor each successive stage in the downward process of the falling nature, but epochs and eras, with differential marks, as palpable, perhaps, as those which separate the aspects of the successive decades of life. And what is far pleasanter, when the character of a neglected and vitiated child is raised by wise culture, the converse change will be found—nay, has been found—to record itself unmistakably upon the faithful page of the countenance; so that charitable institutions have learned that their strongest appeal lies in the request, "Look on this picture, and on that,"—the lawless boy at his entrance, and the decent youth at his dismissal.

The field of photography is extending itself to embrace subjects of strange and sometimes of fearful interest. We have referred in a former article to a stereograph in a friend's collection, showing the bodies of the slain heaped up for burial after the battle of Malignano. We have now before us a series of photographs showing the field of Antietam and the surrounding country, as they appeared after the great battle of the 17th of September. These terrible mementos of one of the most sanguinary conflicts of the war we owe to the enterprise of Mr. Brady, of New York. We ourselves were on the field upon the Sunday following the Wednesday when the battle took place. It is not, however, for us to bear witness to the fidelity of views which the truthful sunbeam has delineated in all their dread reality. The photographs bear witness to the accuracy of some of our own sketches in a paper published in the December number of this magazine. The "ditch" is figured still encumbered with

the dead, and strewed, as we saw it and the neighbouring fields, with fragments and tatters. The "colonel's grey horse" is given in another picture just as we saw him lying.

Let him who wishes to know what war is look at this series of illustrations. These wrecks of manhood thrown together in careless heaps, or ranged in ghastly rows for burial, were alive but yesterday. How dear to their little circles far away most of them!—how little cared for here by the tired party whose office it is to consign them to the earth! An officer may here and there be recognized; but for the rest—if enemies, they will be counted, and that is all. "80 Rebels are buried in this hole" was one of the epitaphs we read and recorded. Many people would not look through this series. Many, having seen it and dreamed of its horrors, would lock it up in some secret drawer, that it might not thrill or revolt those whose soul sickens at such sights. It was so nearly like visiting the battle-field to look over these views, that all the emotious excited by the actual sight of the stained and sordid scene, strewed with rags and wrecks, came back to us, and we buried them in the recesses of our cabinet as we would have buried the mutilated remains of the dead they too vividly represented. Yet war and battles should have truth for their delineator. It is well enough for some Barou Gros or Horace Vernet to please an imperial master with fanciful portraits of what they are supposed to be. The honest sunshine

"Is Nature's sternest painter, yet the best;"

and that gives us, even without the crimson colouring which flows over the recent picture, some conception of what a repulsive, brutal, sickening, hideous thing it is, this dashing together of two frantic mobs to which we give the name of armies. The end to be attained justifies the means, we are willing to believe; but the sight of these pictures is a commentary on civilization such as a savage might well triumph to show its missionaries. Yet through such martyrdom must come our redemption. War is the surgery of crime. Bad as it is in itself, it always implies that something worse has gone before. Where is the American, worthy of his privileges, who does not now recognize the fact, if never until now, that the disease of our nation was organic, not functional, calling for the knife, and not for washes and auodynés?

(To be continued.)

Correspondence.

LIME TONING.

Sir,—Having read with some degree of attention the amusing lamentations of "Cha-meal-ion." I am tempted to tender advice, which, if followed, will not only enable him to bask undisturbed in the sunny rays of success, but will also prove that lime toning is not so difficult a matter as Mr. Hughes seems to think it to be. Use a strong silver bath, and print, if the conditions will admit, in diffused light. Take for each sheet of paper to be toned one grain of chloride of gold, add this to about half the quantity of soda carb. which would be necessary to neutralise the free acid; now pour boiling water (say a pint to five grains of the AuCl³) to drive off excess of chlorine, and lay aside for half an hour when the full quantity of solution necessary may be made by adding cold water. Quantity must be regulated by the exercise of judgment. The saturated solution of chloride and carbonate of lime may now be mixed with it allowing from 5 to 8 minims for each grain of gold employed. Before proceeding to tone the perfect prints, immerse half a dozen or more slightly washed, "roasted," or stained ones. When toned, the bath will be fit for use. Two or three waters previous to toning will be sufficient, that is to say, if the last shows no further deposit of free nitrate. If you think a paper on the chemistry of lime toning would be acceptable to your numerous readers, I shall willingly engage in its preparation; but before doing so, I would ascertain the results arrived at by those who may be tempted to try my method of working.—I remain, yours respectfully,

A PHOTO'S ASSISTANT.

P.S.—I would just observe that should the bath tone very slow, it is a sure sign that too much soda has been employed; if too quick, the alkaline agent must be increased; depth of printing about the same as for acetate bath.

EBOHITE BATHS.

SIR,—Seeing in the last number of the PHOTOGRAPHIC NEWS a letter of inquiry from Captain Dennis Wright respecting the efficacy of dipping baths made of ebonite, I beg you will allow me an opportunity of stating my experience in regard to this matter.

Early in the summer of last year, whilst giving a course of instruction in photography to the officers attending the Royal Artillery Institution, I had frequent inquiries about the chemical efficacy of ebonite, which, on account of its lightness and indestructible character had much to recommend it to the favourable notice of tourists, and others, like my pupils, liable to frequent changes of residence. By way of putting this question to the test of experiment, two ebonite baths were purchased, and used side by side with others made of gutta-percha and glass. I took particular account of their performance, and, as the general result, it was found that the silver solution was more liable to change in the ebonite baths than when contained in vessels of the older materials. The negatives taken were wanting in vigour, and I found, in fact, that metallic silver had become reduced in the form of a brilliant lining over the whole interior surface of the bath, and the solution had acquired an acid reaction.

Shortly afterwards I mentioned this circumstance to Mr. Hugh A. Silver, of the firm of S. W. Silver and Co., Bishopsgate Street, who suggested that the faulty baths might have been prepared from the refuse of the india-rubber manufacture, in which bronze powders and other metallic pigments were likely to be contained. That gentleman told me his firm had recently been engaged in some critical experiments preliminary to undertaking the manufacture of photographic apparatus in pure ebonite, and he kindly offered to place in my hands two of his new dipping baths for comparison with those in common use. With regard to the quality of the india-rubber employed in the composition of the ebonite for these baths it was then stated that all apparatus bearing the stamp of the firm should be made of "virgin gum," and that they were prepared to guarantee that no re-worked rubber should at any time be used in their construction.

Immediately on the arrival of these baths I proceeded to test them in the ordinary way; one bath was started with a fresh solution of nitrate of silver, the other being filled with a supply transferred from a large glass bath, which was acting satisfactorily. By repeatedly testing, at intervals of a week and upwards, I could not detect any deterioration, nor was there any evidence of metallic reduction or liberation of acid; in fact, these vessels answered their purpose admirably, they preserved their shape, bulging but very little, not nearly so much as gutta-percha would have done under like circumstances—their rigidity was, indeed, remarkable, and the solutions left for nearly six months in them remained unimpaired. In regard to weight I found that the bath and air-tight cover, with metal binding screws, hinged support, and dipper complete, weighed, in the aggregate, less than the solution which could be accommodated therein. It should likewise be mentioned that these baths and dippers for 10 by 8 plates were beautifully formed, having their interior surfaces lined with polished plates of ebonite, and the material appeared throughout, so far as one could judge by inspection, to be of uniformly good quality.

As the practical conclusion from these observations, I would call attention to the fact that there are different qualities of ebonite apparatus in the market, and it is, therefore, important to look for the guarantee of quality which the name or stamp of the maker affords, and by all means into decline accepting articles like those which first came to my hands, in regard to which it is almost needless to add that there was no trade mark or means of identification.—I am, dear sir, yours faithfully,

JOHN SPILLER.

Woolwich, August 24th, 1863.

[The bath to which we referred as proving satisfactory in our hands, was manufactured by Messrs. Silver and Co. If we are rightly informed, the manufacture of "Ebonite" is protected by a patent, and any imitation under the name of "ebonite" would be an infringement.—Ed.]

A CASE OF NEED.

MY DEAR SIR,—Having just returned from a small watering place where I found the widow of a photographer of some repute struggling hard for a livelihood with a *wretched* lens and camera, may I ask the favour of your bringing her case before our photographic brethren, professional and amateur, and soliciting their aid towards procuring for this worthy and industrious sister a suitable apparatus wherewith to support herself and *three* orphan children. At her husband's death, being then ignorant of the art, all her lenses, &c., were disposed of by a relative. She has since been taught, and only now fails to attain her object from not having a lens, &c., fit for the purpose. I am sure, sir, you will kindly consent to receive subscriptions, and the smallest donations will be thankfully received.—I remain, my dear sir, your constant reader, AN AMATEUR PHOTOGRAPHER.

Photographic Notes and Queries.

MOISTURE AND ACTINISM.

DEAR SIR,—I, with several of my photographic friends and not a few of your correspondents, have lately been complaining sadly about the want of intensity in their negatives, notwithstanding the recent and present summer light.

I should inform you, sir, that the floor of my glass room is paved with red tiles, and therefore you will readily understand that with a southern aspect the heat is usually very excessive and the atmosphere correspondingly dry. To alleviate the heat, the other morning, I poured through the "rose" of a watering pot a large quantity of water on the tiles, and although in a few moments the water was absorbed, the evaporation continued for several hours. To my gratification on taking a negative it not only came up dense and standing out from the glass, but required no after intensifying from the iron developer. I do not absolutely assert that the dampness in the air of the room had anything to do with the improvement, but on trying the same thing this morning I met with the same pleasing result.—I am, sir, yours very truly, NOEL E. FITCH.

[The fact stated by Mr. Fitch is curious, and as we know him to be a most careful and skilful photographer, his experiments and opinions possess considerable weight.—Ed.]

NEW TRANSPARENT MEDIUM ON TO WHICH NEGATIVES MAY BE TRANSFERRED. NEW PRESERVATIVE.

SIR,—I have not seen any reference to a substance which seems peculiarly adapted as a preservative in the dry plate process, also as a transparent sheet upon which to place negatives instead of glass plates that are so liable to get scratched and broken. I refer to a mixture of gelatine and glycerine; the latter readily dissolves glue or gelatine by the aid of heat in an ordinary glue pot, forming a mixture which, when spread on glass and allowed to set, may be taken up as a beautifully transparent sheet, exceedingly flexible; or the hot solution may be poured on the unvarnished glass negative, and, when set, the impression becomes attached to the gelatine, and is then more convenient for all printing purposes, and the density of the negative is not impaired by varnishing as on glass plates. Such sheets, containing negative images, are most convenient for photolithographic purposes and for photographic printing surfaces generally, as, from its flexible nature, it adapts itself to the sensitive surface of either stone or plate in the closest contact.

Query—If a very dilute solution of the above be applied to a collodion plate sensitized, I feel certain it would prove a valuable preservative, it will certainly make a better combination than gum and honey. It retains its *viscidit*y for years.—Your obedient servant, JOSEPH LEWIS.

Talk in the Studio.

MONUMENT TO BISHOP HOOPER.—We have received from Mr. H. T. Bowers a very fine photograph on a 15×12 plate of a monument which has just been erected at Gloucester, by public subscription, to Bishop Hooper, the Protestant martyr. It is a noble structure, placed in the churchyard of St. Mary de Load, an ancient and curious church built partly upon the foundation of the first Christian church which was built of stone in this country. The photograph is very perfect indeed.

NOVEL USE OF CARD PICTURES.—It is stated that, at a recent great ball, given by the Empress Eugenie, each guest was requested to bring a card picture of the costume in which he appeared at the ball. The portraits were then collected, and placed in an album for the boudoir of the Empress.

PHOTO-LITHOGRAPHY.—The *Times* gives the following from *Calignani's Messenger*, a few days ago, both papers evidently fancying the matter a novelty:—"A curious communication was sent in last week to the Academy of Sciences, by M. Morvan, in which he describes a method of his for obtaining direct photographic impressions upon stone, and which he can afterwards print off. He first gives the stone a coating, applied in the dark, of a varnish composed of albumen and bichromate of ammonia. Upon this he lays the right side of the image to be reproduced, whether it be on glass, canvas, or paper, provided it be somewhat transparent. This done, he exposes the whole to the action of light for a space of time varying between thirty seconds and three minutes, if in the sun, and between ten and twenty-five minutes, if in the shade. He then takes off the original image, and washes his stone, first with soap and water, and then with pure water only, and immediately after inks it with the usual inking roller. The image is already fixed, for it begins to show itself in black on a white ground. He now applies gum-water, lets the stone dry, which is done in a few minutes, and the operation is complete; copies may at once be struck off by the common lithographic process. The process may be explained thus:—The varnish has been fixed and rendered insoluble by the action of light wherever it could penetrate; but, on the contrary, all the parts of the varnish protected by the dark portions of the image still retain their solubility, and are, therefore, still liable to be acted upon by the soda and acid contained in the soap, of which they, moreover, retain a part of the substance. Hence the action produced on the stone is a combination of etching and lithography. The advantages of the process may be briefly summed up as follow:—Simplicity and rapidity in the operation, exactness in reproducing the design, no need of negative impressions on glass or paper, the positive original comes out positive, the original design or model is not spoiled during the process, and the cost is trifling, owing to the cheapness of the substances. [The process here, not very clearly stated, does not appear to differ much, in principle or application, from Cutting and Bradford's process, patented some years ago.—Ed.]

To Correspondents.

HENRY THOMPSON.—The best cement we know for joining glass is marine glue; we have not found it injure the nitrate of silver solution. 2. Chemically, the print sent is very good; but there is room for improvement in the posing.

AN AMATEUR.—The sensitive plate should remain moist and ready for use a few minutes at all seasons, unless something be wrong. A horny repellent collodion is more apt to dry quickly than a somewhat porous and absorbent film. It has been recommended to place a piece of wet blotting-paper behind the plate, which by keeping it cool and filling the dark slide with moisture tends to prevent the plate drying. A plate may dry in daylight after fixing without any detriment to its subsequent intensification. We intensified a plate successfully a day or two ago, which was taken upwards of two years ago, and has stood in the light a great part of that time.

IGNORAMUS.—You may develop any collodion with iron, whether especially manufactured for iron development or not, and you will generally gain in rapidity by doing so. 2. You will find a good formula for collodion in our *ALMANAC*, which will answer your purpose and for most of the dry processes. 3. We are uncertain as to the suitability of the collodions you name; they will probably require the addition of a little more bromide. 4. You may use the ordinary sweet wort from a brewery for the malt process; it should be filtered. 5. It is quite legal to make acetic acid by the distillation of acetate of soda or potash with sulphuric acid. It is also legal to distil ether; and to redistil alcohol, but not to manufacture it without paying duty. 6. Citric acid is made by adding chalk to lemon or lime juice, which forms insoluble citrate of lime. This is decomposed by adding dilute sulphuric acid, and on evaporation crystals of citric acid are obtained. 7. Citric acid does not spoil by keeping in crystals. 8. Yes. 9. A candle will do no harm in the dark room unless its flame be brought too near an open bottle of collodion or ether, or its light too near an excited plate. 10. You might recover your silver as a carbonate and then produce nitrate

direct if you used distilled water always for washing; but if you use common water, some of the silver will be thrown down as a chloride by the chlorides in the water. A great deal of the silver in waste developing solutions is gradually thrown down as a metallic powder.

YOUNG ENGLAND.—An ordinary spirit varnish is sometimes used to varnish card pictures, but we do not consider them improved by the operation. 2. You may make chloride of gold from a gilder's waste by simply dissolving it in nitro-muriatic acid, as we have often described.

ST. DENNIS.—We believe that Marion and Co., of Soho Square, manufacture albums, and also Mr. Bourquin, of Newman Street, Oxford Street.

AMATEUR.—The defect in your tannin plates appears to be fog. Use a weaker and more acid developer; or add a little acid to your nitrate bath. We do not consider the printing through of the sky a defect if the picture be good in other respects. With a view-lens of $\frac{1}{4}$ -inch focus and half-inch stop, an exposure of two minutes in a bright light is longer than necessary with an ordinarily good tannin plate. 2. With calotype paper, an exposure of five or six minutes would probably be sufficient in a bright light, with lens of 12 inches focus and $\frac{1}{8}$ ths stop. 3. So far as we can judge, without absolute comparison, we should say that, in point of sensitiveness, ordinary tannin plates and calotype paper were very similar.

W. G.—We have only tried one out of the three you name, the second, and it was very good.

LIME TONING.—A correspondent, who, a few weeks ago, lamentably failed with a lime bath we had described, encloses us a couple of very fine prints indeed, stating that he tried it again when it had stood a fortnight, and that all now goes well. It only required age.

A.—We think that the tannin process exceeds in simplicity and certainty the Fothergill process.

A.—If a portrait painter who advertised in our pages, June 26th, under the signature "A," will call at our office, he will find another communication awaiting him.

W. BASSANO.—We understand our correspondent to mean that he used a bath of the strength mentioned, daily, and not the same identical solution. If the latter were meant, no specific deduction could be drawn from the fact, except as to the strength, without knowing the quantity of solution. A weak or a strong bath will become impoverished, and requiring strengthening and renewing, but the economy of the weak bath, if satisfactorily established, would consist in leaving much less free silver to be removed by washing. We have printed with very weak baths successfully, but we have an impression that when the tendency to mealiness exists, they promote it, and can only be used with very good vigorous negatives. 2. We are not aware that any one has done anything with gum and formic acid as a preservative. We shall be glad to hear of your results. 3. India-rubber dissolved in kerosene, or other solvent, possesses the advantage over albumen as a preliminary coating, that there is no danger to the bath from its use, which is not always the case where albumen is used.

CHALK.—We are glad that our suggestion has helped you. Had we seen a plate we could have told you the cause of the defect at once. Possibly the fact that over-iodizing will produce those irregular fringe-like stains is not sufficiently explained in many works on photography.

PERPLEXITY.—We will take an early opportunity of trying the paper and reporting.

JOHN VANHEM.—We will make some inquiry into the matter. It is quite possible the matter is susceptible of some explanation. We have an impression that the manufacturer has been very ill.

SHAW AND SONS.—The group and general artistic arrangement are pretty good, there is a little want of sharpness, possibly from movement.

G. L.—Carbonate of lime is slightly soluble, in most common waters, as you may easily prove by agitating the water with a little chalk, and then filtering the water until it is quite clear and bright. Now add a little oxalic acid, which will cause turbidity, and finally a slight precipitate of insoluble oxalate of lime.

Several Correspondents in our next.

Photographs Registered during the Past Week.

- MESSRS. JEW AND PEASEY,** Tewkesbury,
Photograph (from oil painting) of entire horse called "Young Douglas."
- MR. AUBREY JOHN DEAN PAUL,** 1, Thames Place, Putney,
Two Photographs of Captain Speke, Discoverer of the Source of the Nile.
Photograph of Rev. Charles Aldridge.
- MR. JOHN HAWKE,** 53, Union Street, Stonehouse Devon,
Two Photographs of Col. W. F. Hopkins, Aide-de-Camp to Her Majesty.
Two Photographs of Rev. Dr. Harris.
Two Photographs of Rev. Robert Eardley, B.A.
Two Photographs of Rev. Wm. P. Slater.
Photograph of Major-General Holloway, C.B., Aide-de-Camp to Her Majesty.
- MR. JOHN DAVIS WAYMOUTH,** Nailsea,
Two Photographs of Rev. Wm. White.
- MR. HENRY THOMAS BOWERS,** 123, Southgate Street, Gloucester,
Photographic View of the "Hooper Memorial," at Gloucester.
- MR. H. J. WHITLOCK,** Birmingham,
Two Photographs of Mr. Spooner.
- MR. WILLIAM H. HILTON,** 22, Kensington Place, Brighton,
Two Photographs of the 1st Sussex Volunteer Artillery Band.
- MR. THOMAS ARBAX,** 202, Hope Street, Glasgow,
Two Photographs of the Rev. David Young.
- MR. WM. JOSEPH EGGAR,** 2, Grove Cottages, Barrington Road, Brixton,
Photograph of a Seal used by King Charles II. whilst in Exile.
- MR. PETER MATTIAND LAWS,** 58, Blackett Street, Newcastle-on-Tyne,
Three Photographs of Rev. Richard Leitch.
- MR. WILLIAM GERNAIE,** 23, Nunn's Street, Newcastle-on-Tyne,
Two Photographs of Mr. Southern, Comedian.
- MESSRS. W. AND D. DOWNEY,** 9, Eldon Square, Newcastle-on-Tyne,
Photographs of Rt. Hon. C. Pelham Villiers, M.P.; Rt. Hon. Frederick Peel, M.P.; Sir W. Dunbar, Bart., M.P.; Thomas Baring, Esq., M.P.

THE PHOTOGRAPHIC NEWS.

Vol. VII. No. 258.—August 14, 1863.

CONTENTS.

	PAGE		PAGE
On the Management of the Nitrate Bath.....	385	Copyright in Works of Fine Art	392
Reproduction and Copyright	386	Recent Patents	393
Photographs in Printing Ink	387	Correspondence — Foreign Science — An English Amateur's Glance at French Photography — Cumulative Effects in Photography—Formula for the Determination of the Com- parative Duration of Exposure, &c.	393
Photographic Chemicals	387	Photographic Notes and Queries—Glass for Dark Rooms—Mea- suring the Angle of Photographs	395
An Attempt to Secure Certainty in Gold Toning. By a Photo- grapher's Assistant	388	Talk in the Studio	396
Photometry. By Sig. Garneri, of Turin.....	389	To Correspondents.....	396
On Malic and Maleic Acids as New Isoisomeric Bodies. By H. Kammerer	390	Photographs Registered during the past Week.....	396
On the Composition of the Photographic Picture. By Eugene Sahier	390		
Doings of the Sunbeam	390		

ON THE MANAGEMENT OF THE NITRATE BATH.

THERE is no preparation used by a photographer of more vital importance than the nitrate of silver bath, and yet none in regard to the condition of which he possesses so little certainty. By care he can secure collodion of constant quality; or at the worst he can be certain that the stock in use for a given period, say a day or a week, or months, continues unchanged. In his developing solution he can secure just what conditions he may please, unvarying in all respects if he desire. But in regard to the nitrate bath, none of these things are possible: it is continually changing; it is not the same bath for two consecutive plates. In using the collodion and developer a definite portion of each is consumed, and what remains behind continues of the same quality. The nitrate bath is continually being deprived of some of its elements and receiving an accession of others; there is a constant interchange of particles. It is composed, to begin with, of water, nitric acid, silver, iodine, and perhaps a trace of bromine. On the immersion of every plate it is deprived of a portion of its water and silver in uncertain quantities. It is supplied in place of the silver with some other base, or a mixture of bases, it may be cadmium, potassium, ammonium, lithium, magnesium, calcium, zinc, and occasionally a trace of iron. It receives besides continued accessions of ether and alcohol and probably traces of other organic matter. It also probably continually gains accession of some traces of iodine and bromine, and there is a gradual accumulation of iodo-nitrate of silver. Besides the decompositions and recompositions which are intended to take place, and which are anticipated in the order of things, there are others not always intended which are uncertain and beyond control, such as arise from the liberation of nitric acid and oxygen by free iodine in the collodion, and from the reactions between ether and alcohol and free acid. There may be the train of complications arising from the addition of acetates. There may be occasionally other decompositions arising from unknown empirical additions to increase the sensitiveness or density of collodion, or the use of impure methylic solvents in its manufacture. When all these considerations are remembered, and that the changes produced never remain for two plates the same, it is scarcely surprising that nitrate baths occasionally "get out of order."

It happens fortunately for photography and photographers that a nitrate bath of originally sound and healthy constitution, is very hardy. If made originally from pure materials, and worked with ordinary care and moderately pure collodion, it will continue parting with much it originally possessed, and receiving much foreign addition to its constitution without striking work or being attacked with sickness. Nevertheless, of late there have been frequent complaints from good photographers, amateur and professional, of the rapidity with which their baths get out of order and

refuse to give satisfactory results. Various causes are alleged. Some attribute it to the use of bromides in the collodion; others, to the uses of methylated spirits as solvents of pyroxyline; others to the use of ordinary alcohol distilled from potato, malt, &c., and containing essential oils; others, to organic additions to the collodion; others, to impure and unsuitable iodizing salts; others, to the prevalence of adulterated or impure nitrate of silver.

All these causes may, occasionally, be chargeable, but there is another, which, also, possibly has more influence than is recognized. We allude to the enormous amount of work the nitrate bath frequently gets, to what it used to do a few years ago. Since the introduction of card-portraits, we imagine that in many portrait establishments ten-fold more negatives are produced now than were a few years ago; and the nitrate bath gets a proportionate increase of work in the time.

Without adverting further at present to these causes which are largely beyond the control of the photographer, it becomes an important question with him, therefore, to consider, first, how to best keep his bath in order so as to secure constant conditions, and next how to rectify it when out of order. We shall devote a few lines to each of these subjects.

How to Make and Keep the Bath in order.—Make the bath of a strength of thirty grains to the ounce for summer, and thirty-five grains, or forty, to the ounce for winter use. Iodize it, by leaving a large coated plate in for a few hours. If it work foggy neutralize with freshly precipitated oxide of silver, or carbonate of soda, and sun for a few hours. Then filter and try again, working it as nearly neutral as possible, adding, if acid be necessary, the smallest trace of nitric acid. We will now suppose the bath is in good working order, and the object is to keep it so, or what is equivalent to secure the greatest possible constancy of good conditions.

We now ask the careful attention of our readers for a moment. We have already said that the nitrate bath is beginning to change its constitution from the moment it is brought into use. No care can prevent the accumulation of foreign matter in the bath, but the greater portion of this would be comparatively inert in determining the character of the sensitive film of iodide and bromide of silver, if we could remove it from the free nitrate on and in the film which is reduced in developing. The affinities exist between iodine and bromine and the silver in the solution, and these elements will combine, forming iodide and bromide of silver, regardless of the foreign matter which may be present. It is true that foreign matter present may become to some extent entangled in the film with these elements as they combine, the more so if the idea be accepted of the formation of sensitive double salts of iodide and nitrate of silver and bromide and nitrate of silver, but it is to the presence of the foreign matter in the free nitrate on the plate that irregular reduction, causing stains, fogs, pinholes, &c., &c., is chiefly due.

How are these impurities in the free nitrate to be got rid

of, then? Very simply: by the use of two baths. Most professional photographers in large practice have two or three baths going, and some require a new one every two or three days, not because the old one is exhausted, but because it is saturated with foreign matter, that it does not work well. Proceed as follows:—Make a new bath as usual, and get it into perfect order; do not excite the plates in it, but in the old one which is supposed to be done. When the plate is withdrawn from this, covered, it may be, with greasy lines, from the accumulation of ether and alcohol, or covered with a sandy looking deposit, the sure forerunner of pin-holes, &c., instead of putting it into the dark slide, put it into the new bath for a few seconds, moving it up and down once or twice. Now remove it to the dark slide—the greasy lines from ether and alcohol are gone—it looks perfectly smooth and even—the sandy deposit is removed, and all loose particles which have accumulated in the first bath from long use are washed off—the contaminated free nitrate which saturated the film is almost entirely replaced by a new solution. When the developer is applied it flows evenly over the plate, does not readily decompose, and, whilst it develops the image, it reduces pure nitrate of silver, and thus avoids the fog, streaks, pin-holes, &c., which are the common result of free nitrate containing organic and other contaminations. The negative consequently possesses all the delicacy, cleanness, and richness of colour which are the general result of a new pure bath.

Besides the good results, there is a great saving effected. The new bath receives such slight additions of foreign matter that it serves as a second bath a very long time; whilst the first bath may be used much longer than it could possibly be under other circumstances. When the first begins to be exhausted and useless, the second bath may be put in its place, and a new one made for the second immersion.

Some years ago, when glass positives were in vogue, we tried a similar plan, but with a slight modification. The second bath contained only ten grains to the ounce, the object being to avoid the rapid precipitate of a large amount of surface silver which had a tendency to bury the half-tones and give a coarse image. With the dilute second bath we had development more under control, and secured great delicacy and fine modelling. Our attention was recently called to the advantages of the second bath by a well-known metropolitan portraitist. He had been somewhat troubled by the frequent necessity for new baths. Every week three ounces of nitrate of silver were necessary for replenishing the old bath or making a new one, and a large accumulation of bottles of discarded nitrate solution began to fill the dark-room. The ether, alcohol, &c., accumulated and spoiled the solution much more rapidly than it was used up, and time was too precious to permit of evaporating, sunning, &c. The plan of using two baths, as we have described, was therefore tried, and found to answer admirably; the increased comfort, economy, and excellence of results, being out of all comparison greater than before. The trouble was found to be comparatively trifling. A plate was coated and excited in the old bath; then removed and placed on a piece of blotting paper to drain. Whilst it was doing this, another plate was put in the old bath, and then the first was sufficiently drained for immersion in the second bath, where it was allowed to remain about half a minute before placing in the dark slide.

Replenishing the Bath.—The common method of replenishing the nitrate bath is by the addition of fresh solution of the proper strength, or of a stronger solution where there is reason to suppose that the strength of the used bath has become impoverished. From some scarcely explained cause it is often found that the first result of such replenishment is not always improvement. It not unfrequently happens that a tendency to fog and streaks is the first result. These troubles may however be avoided by adopting another method of proceeding. Instead of making new solution, first take the proportion of water and add to the old solu-

tion. This will throw down some portion of the accumulated iodide which was dissolved in the old solution. Now filter, and add the crystals of nitrate of silver necessary to make up the proper strength. By adopting this method it will often be found that the bath is much improved, and the troubles attendant on the old method avoided.

We must defer our remarks on the correction of baths out of order until our next.

REPRODUCTION AND COPYRIGHT.

ONE of the most interesting features which struck us as distinguishing the French Photographic Exhibition, was the magnificent display of photographs from modern copyright paintings, rivalling engravings in all points in regard to which engraving is supposed to possess especial advantages, and decidedly surpassing it in others. In faithful translation of colour, in chiaroscuro, and in delicacy, vigour, and beauty, many of them—we are especially speaking of those of Bingham—leave nothing to be desired; whilst in accurate rendering of exact drawing, and even the very touch and handling of the artist, and in cheapness, they possess decided advantages over engraving.

In this country the experiment of producing photographs from modern paintings has not been tried to any considerable extent. This has been doubtless due to two causes. In the first place, the absence, until last session, of any means of securing a copyright in such productions; and in the second place, little demand existing for such work, there are not many good photographers who have devoted attention to the especial production of such works, so that an impression largely prevails that it is impossible by means of photography to translate into satisfactory monochrome the varied bright hues of modern painting. This first reason has ceased to exist, the new act affording effectual protection both to the painting and the photograph. In regard to the second the demand only needs to arise in order to bring forth capable men. Mr. Thurston Thompson's photographs of Turner's paintings, and Mr. Annan's copies of the prize paintings in the Glasgow Art Union, are sufficient evidence of the existence of capability in this direction, and we are satisfied that there are many more if the demand arose for their services. Mr. Gambart, in his recent pamphlet on copyright, suggests a third reason, the low estimate into which photographic reproductions have fallen having been chiefly confined to the hands of pirates. He says:—

Want of justice to the art of engraving, and its being delivered as a prey to unprincipled photographers, has been more destructive to photography than can be generally understood. This course has not destroyed a trade which existed before, but prevented one of great promise from being developed. Photographic copies of engravings, having got possession of the market, are produced by only the lowest practitioners. No photographer of standing or ability will join in such a course. The sale of copies of English engravings is only carried on by hawkers or shopkeepers of broken fortunes, and their competition being unrestrained by want of capital, such copies, originally sold at from 1s. to 6s. each, are now produced at the lowest possible price—one party actually supplying the trade with small photographic copies of my engraving from "The Light of the World" at three-halfpence a dozen, so that the vendors can make but a slender return out of their nefarious practices. But, the low prices thus established ruling the trade, publishers of photographs in which there would be copyright, and consequently capital invested, have no chance—the necessity of charging a corresponding high price limiting their sales to the lowest ebb. And yet what a fine future photographers have before them! Already in France, under an efficient copyright law, the photographer competes successfully with the engraver. Messrs. Bingham are reproducing Meissonnier's pictures in photography with the greatest success. Gérôme's "Gladiators" and "Death of Cæsar," and many other fine works are published in photography also, and large sums have been paid for copyright to the artists by the publishers of these photographic reproductions.

What is the case in England? Where are the pictures reproduced by English publishers of photographs? What sums have painters received from photographers? I fear the answer is, None! The sole cause of the unprofitableness of photography, as a medium for reproduction in England, is to be found in the trade in photographic transcripts being in the hands of pirates. I do not speak on mere speculation and without proof: I have given photography a trial. I published, in photography, one of Mdlle. Rosa Bonheur's finest pictures, "The Shetland Ponies," and although the picture was most creditably reproduced by Mr. Thurston Thompson, I have, after six months of publication, not sold one hundred copies; the reason is obvious, printsellers will not buy my photographs at the price I am obliged to charge (not having stolen the copyright, but having paid for it a fair price to Mdlle Rosa Bonheur as part of the purchase of the picture), in order to recompense myself by spreading my outlay over a fair edition, besides requiring an additional remuneration for my industry. Of course my experience is of a dead failure and a losing speculation; whereas, if the photographic trade was not affected by the disease of piracy, not only would my publication be successful, but publishers of photographs would compete with publishers of engravings in the purchase of copyrights, and, by further enhancing the value of artistic talent, encourage artists to greater efforts in view of the prizes held out to successful competitors in a race where fortune follows fame.

If Mr. Gambart's view of the case be a correct one, it is unfortunate for the public and for photographers. A copyright law, efficient so far as this question is concerned, is now in existence, and consideration of want of protection need now operate to prevent photography, in many cases, taking the place of engraving for the reproduction and extensive distribution of the works of modern painters. In France it is not simply paintings which are not worth engraving which are so reproduced; some of the first artists of the day thus deal with their best paintings. We saw in Mr. Bingham's studio, waiting for reproduction, one of Meissonnier's paintings not exceeding twenty-four inches by eighteen in size, which had been sold for two thousand guineas; and we saw various copies of other first-class paintings which had just been completed. What are the precise copyright arrangements in France, or whether they possess any advantages over the copyright law recently adopted in this country, we cannot say; but we cannot see any valid reason whatever why this system of reproducing copyright paintings by photography for publication should not be adopted in this country. The success of last year's experiment has induced the Glasgow Art Union to repeat it, and photographs of original paintings are again to take the place of engravings in the general distribution, the work being entrusted to Mr. Annan, who so successfully produced last year's pictures.

The great success of Mr. Bingham in this department of the art has led to the conjecture amongst some persons that he possesses some secret upon which success depends. An eminent Parisian photographic authority expressed to us his conviction that this was the case, remarking that he had never published his process, and that, as his productions so far surpassed all others of the same class, it was probable their excellence depended on superior method. In a subsequent conversation with Mr. Bingham, he informed us that his only secret consisted in the use of judgment and careful manipulation. He used a collodion containing one part of a bromide to three of an iodide, about four grains and a half of the latter and one and a half of the former, the base generally being cadmium. The pyroxyline was made by a formula very nearly resembling that we publish in our YEAR BOOK, with the exception that the nitric acid contains a portion of nitrous acid. An iron development was used, generally somewhat strong, but varying with circumstances. Mr. Bingham has so long used a bromo-iodized collodion and iron development, and so thoroughly proved their advantages in trying work, that he had been much surprised and amused to see the question of their value recently raised in the English journals. The question, in his practice, did not admit of a doubt.

Mr. Bingham's studio is one of the noblest in dimensions,

and the most convenient and comfortable, we have seen. Its length is between thirty and forty feet, its height is not much less, we should think, than thirty feet. It has a ridge roof with a very steep pitch, the ridge running crosswise of the room. The sitter can be placed at either end, the half of the roof under which he is placed being covered up with blinds and the top light from the other side reaching him at an angle of about forty-five degrees. Each side is fitted with glass and possesses double moveable sashes, one of which is glazed with ground glass for cutting off direct light when necessary. A gallery or balcony runs round outside the studio. The camera is placed in a moveable dark room which prevents diffused light entering the camera. The arrangements throughout were amongst the most perfect we have seen.

PHOTOGRAPHS IN PRINTING INK.

In some interesting remarks by Mr. Sutton, in the last *Photographic Notes*, on Mr. Pouncy's new process, he refers to a very important mode of using it. He says:—

"If it is required to exhibit a carbon print upon plate paper, so that it may have exactly the appearance of an engraving, with all the peculiar merits and qualities of a photograph—and this is certainly a very desirable method of printing—then the print must be transferred from the tracing paper to the plate paper. This is very easily done by a peculiar process, which only occupies a minute or two, and requires a lithographic press. The tracing paper comes off as clean as it was at first, and the ink picture is transferred to the white paper, non-reversed."

If this can be effected satisfactorily, it will be, we apprehend, one of the most important applications of the process. We have not seen a specimen treated in this way; but shall look with interest for results in this direction. Mr. Sutton further adds:—

"In the same way, the carbon print can be transferred to a stone or zinc plate, and is then ready to be put into the hands of the lithographic printer. The mode of transferring is, however, quite new, and the stone, instead of being dry and hot, as in the usual process, is damp when the transfer is laid upon it. This is another of the novelties included in Mr. Pouncy's patent.

"Let us now recall to mind what has been done.

"1st. A positive print has been taken in printing ink upon transparent paper, which may either be viewed as a transparency, or exhibited mounted upon cardboard.

"2nd. A positive print in printing ink has been taken upon white paper.

"3rd. A positive print in printing ink has been transferred to a lithographic stone,—the impression, which is already in ink, being perfect in all the gradations of tone.

"In all previous attempts at Photo-Lithography the image upon the stone has been perfect in half-tone, but it has not been obtained in ink, only in bichromate of potash, or asphaltum; and the difficulty has been to preserve the half-tone when the ink is applied. Mr. Pouncy has overcome that difficulty, and by his new process has obtained a perfect image in fatty ink upon the stone. It is this which constitutes the solution of the grand difficulty in Photo-Lithography. It only remains for the printer to etch the stone slightly, and produce the grain, which is an essential characteristic of a lithograph, and then print off impressions in the press."

PHOTOGRAPHIC CHEMICALS:

THEIR MANUFACTURE, ADULTERATION, AND ANALYSIS.

THE metal *arsenic* next claims our attention. Many compounds of this element are of value in photography, and are in other respects of considerable importance. What is commonly known as arsenic is not the metal properly so

called, but its teroxide, arsenious acid, a white powder. Arsenic itself is a true metal in physical appearance, being tin-white inclining to steel-grey, and possesses a bright metallic lustre. It has one property which distinguishes it from all other metals; it will not fuse. When heated in a glass tube it begins to volatilize at a dull red heat without previously fusing, subliming and condensing in the form of a coherent crystalline mass, not very hard, but very brittle. If an attempt be made to fuse it by heating it in a sealed glass tube, the tube bursts, but no fusion takes place.

By far the most important compound formed by this metal is the teroxide, arsenious acid, above mentioned. This is generally formed when metallic arsenic is heated in the air till it volatilizes. It then burns with a reddish smoke, or when more strongly heated, with a pale blue flame, having an odour of garlic. When the metal is wetted with water and exposed to the air it likewise becomes superficially coated with arsenious acid. When the metal is finely powdered and then moistened with water, it oxidizes so rapidly as to become heated, and in one instance a large quantity (8 lbs.) actually took fire spontaneously. When arsenic is heated with oil of vitrol or dilute nitric acid, arsenious acid is formed. On the large scale arsenious acid is prepared by roasting arseniferous minerals in a furnace from which the fumes are conveyed into a horizontal condensing chamber called the *poison-trap*, or into a building called the *poison-tower*, containing a number of chambers placed one above the other. The crude arsenious acid obtained in this manner is purified by resublimation, having been previously mixed with a small quantity of crude potash to retain the sulphur. Arsenious acid occurs in two varieties, crystalline and amorphous. The former is the kind usually met with in commerce. The amorphous variety is obtained by heating the common variety suddenly or under increased pressure. It then forms a transparent, and colourless glass, which, upon keeping for a few months, becomes white and opaque. During the passage of this amorphous acid to the crystalline state a very remarkable phenomenon of the emission of light is observed. When from one to one and a half parts of transparent arsenic glass are dissolved by half an hour's boiling in a mixture of six parts fuming hydrochloric acid and two parts of water, and the solution left to cool as slowly as possible, the arsenious acid crystallizes in transparent octohedrons, and the formation of each crystal is accompanied by a spark; on agitation, which gives rise to the formation of many new crystals, a corresponding number of sparks is produced. If from four to six parts of arsenic glass are dissolved in the above mentioned mixture, the light produced by the crystallization is sufficient to illuminate a dark room. As long as the deposition of crystals goes on so long is light perceived on agitating the liquid; and this appearance may be visible on the second, and even, though very faintly, on the third evening. If the liquid be then boiled so as to dissolve the remaining portion of the nitrous acid, crystallization again takes place, accompanied by emission of light, though not so bright as before. If the liquid be rapidly cooled, the acid separates in the pulverulent state, and little or no light is emitted. This production of light during crystallization is not uncommon, but we are not aware of any compound which emits it in such abundance as arsenious acid. Much remains to be done by physicists in this branch of science, and it would be well worth some experimentalist turning his attention to this almost neglected field. Even as the subject now stands, we see that a dark room can be illuminated by the crystalline light of one of the cheapest chemicals, and if experiments were specially instituted in the endeavour to exalt or intensify this action we can well imagine that some most valuable facts would be elicited.

It is almost superfluous to say that arsenious acid is one of the most violent among the acrid poisons. It has a rough taste, slightly metallic and afterwards sweetish.

The solubility of arsenious acid in water is variously stated by different authorities, varying, indeed, as much as

from one part in six of water to one in sixty; probably one in forty is about the true proportion. Its aqueous solution is transparent and colourless, and reddens litmus slightly. Arsenious acid dissolves easily in an aqueous solution of potash, forming an oily, alkaline liquid, which, upon evaporation, leaves a gummy mass. It is very difficult to obtain a definite crystallizable arsenite of potash.

When arsenious acid is heated with an oxidizing agent, strong nitric acid for instance, it takes up two additional equivalents of oxygen, and from As_2O_3 becomes As_2O_5 arsenic acid. This acid has recently become of some considerable commercial importance, owing to the fact that it is the best and cheapest oxidizing agent which can be used for the conversion of aniline into rosaniline and its salts (commonly known as magenta). Commercially it is prepared by dissolving either metallic arsenic, or arsenious acid in strong nitric acid, to which a small quantity of hydrochloric acid has been added. The liquid is evaporated to dryness and, if it be desired to get rid of all the water, the residue is heated to redness. Arsenic acid, after fusion, is colourless, transparent, and glassy; at a low red heat it melts; it reddens litmus strongly and is excessively poisonous. At first it is almost tasteless, but afterwards it tastes very sharp and acid. Arsenic acid deliquesces in the air; it dissolves slowly in six parts of cold water, more quickly in two parts of hot water. On evaporating the solution a syrupy substance is obtained from which small crystals of arsenic acid are deposited. In aqueous solution, arsenic acid is colourless.

This substance has recently been the subject of considerable discussion in a court of law, on which occasion, as is usual when scientific points have to be argued before a jury, the chemists were ranged about equally on each side. A patent was taken out for the employment of *dry* arsenic acid in the manufacture of magenta. It was found by other parties (defendants in the action,) that *anhydrous* arsenic acid would not answer the purpose, but that a certain quantity of water was necessary for the decomposition. Just so, said the plaintiffs, we admit that a little water must be present, but that is understood when we speak of *dry* acid; we obviously mean the common, air-dry substance, looking dry to the eye and feeling dry to the touch, and this common dry acid contains the necessary amount of water. The trial resolved itself into a discussion as to the relative values of *dry* and *anhydrous*. The latter term means absolutely and positively free from every trace of water, and if *dry* meant the same thing, the patent was invalid; whereas if *dry* were held to mean such a state as would look and feel *dry* to an ordinary observer, the patent was good. Ultimately it was decided that the latter supposition was correct, and in this view of the case we most certainly agree. *Anhydrous* is not a term capable of being employed in ordinary life. It is strictly a scientific word, and in chemical treatises is always used in its true exact sense. Powders, apparently the driest, are exposed to a high temperature in a current of hot air, in order to render them perfectly anhydrous; we talk of getting a gas anhydrous when there may be only 1-10000ths of its weight of water present to begin with. Moreover, the term *anhydrous* is used indiscriminately to imply freedom from water, whether in the form of vapour, liquid, or ice, but the term *dry* is exclusively used to denote freedom from *liquid* water. Thus we constantly speak of *dry* bread (containing 30 per cent. of water), *dry* steam, *dry* snow, and *dry* ice; but to speak of *anhydrous* steam or *anhydrous* ice would be an absurdity.

AN ATTEMPT TO SECURE CERTAINTY IN GOLD TONING.

BY A PHOTOGRAPHER'S ASSISTANT.

The manifold difficulties which beset the labours of the photographer, must of themselves be sufficient to convince the most prejudicial observer that, however strong the claims

photography may have in demanding its recognition as a fine art, it cannot, as yet, legitimately take its place in the list of perfected sciences; for, strictly speaking, the term science can only be applied where principles are reduced to a system, the governing laws of which must be so clearly defined that the student may regard them as the friendly finger-post to guide him in his researches.

Accepting as a criterion the discrepancies that occur in the experience of those who have been experimenting in lime toning, the correctness of the foregoing remarks will be admitted; for, whilst the few are successful, the many still despairingly cry, "Who will deliver us from the present evil?" Meal, meal, every formula we try; every scheme we adopt prove failures. Oh for the universal specific to rid us of this direful disease! To seek a remedy without an attempt to discover the true cause, by the practice of observation, is to place us on a level with empirics in general, whose success is the results of chance, the presiding goddess of which is seldom lavish in the distribution of her capriciously offered favours.

Touching the subject before us, the first question suggested for consideration, is the nature of the disease. We are all but too familiar with its appearance: are we so familiar with its nature? I trow not, or mealiness could long ere this have been banished from our printing rooms.

Long and patiently repeated observations have strengthened and, I may venture to add, confirmed the opinion expressed on this subject in a former paper, viz., that what we term mealiness is, in reality, the removal of the reduced silver from the more thinly coated portions of the paper surface. However carefully the paper is manufactured, there will be found minute threads on its surface, which, after pressure, stand out in grain-like relief, receiving the thinnest coating of albumen, and, consequently, the smallest proportion of silver, which, when acted upon by the toning solution, readily dissolves out, leaving the whitened surface in speck-like comparison with the adjacent perfectly toned, because more stable parts. Hence, what we term bleaching is the results of bleaching or the action of reduction on an uneven surface; and the many causes which produce the evil, if minutely examined, will be found to act as accelerators to the above described influence. If a perfectly smooth surface could be attained to receive the coating of albumen, mealiness could never make its unwelcome appearance, over-bleaching would produce flat prints, nothing more; and here I would suggest, that a portion of the unprofitable labour employed on the surface of paper after albumenizing, if applied previous to its receiving the coating of albumen, it would go far to remedy the evil. But accepting and endeavouring to make the best of things as we find them, we now enter on a consideration of the means at our disposal that will enable us to hold in check the bleaching power of our toning solutions. This power has been sought after in various directions, and the conclusion arrived at is, that until we can find a true theory for explaining the chemistry of toning action, the power to govern its movements will be denied us. I cannot admit the soundness of this mode of reasoning, for although the intricate changes which take place during the process of toning, may not be understood, we are not denied the power of reducing its general principles to something like order, and until this is done we shall even be floundering in a chaos of dark insoluble perplexities. As an illustration to my meaning, I may be permitted to refer to the electrician. He knows absolutely nothing respecting the constitution of the subtle fluid with which he has to deal, swift as the lightning's flash it moves. Yet a knowledge of the laws by which it is governed enables the individual described to hold it under perfect control. What are the bleaching agents employed in the process of alkaline toning? We answer, chlorine in contact with gold: and in the lime bath, also chlorine in combination with lime; but, this agent, until separated from its base by another power, remains comparatively inert. The decomposing influence here employed is the free acid introduced with the gold. Without venturing

an explanation as to the manner in which this is effected, we would just say, hold in check the cause, and you have at command the effects; remove the acid and you destroy the bleaching power; yes, and the same time stop toning action also, for the one must accompany the other. Non-bleaching in most cases means non-toning; proof of this may be found in the fact that a toning compound of whatever description may have its action destroyed by saturating the solution with carbonate of lime, or by the addition of any alkaline agent in sufficient quantity to destroy every trace of free acid. Whether the bath be old or new, strong or weak, the same result will follow; then, with this knowledge, our path lies straight before us. Reduce the bleaching power to the lowest point that can be admitted without destroying toning action, and this may be accomplished by an observance of the rules laid down in my last brief and hurried communication. By the application of heat remove a portion of chlorine from the gold, partially neutralize the free acid with soda carb., the carbonate of lime introduced with the chloride will remove as much as required of the remainder; if bleaching is too strong, add more soda; if weak, and toning is slow and staid, reduce the quantity of soda. Keep on experimenting until you have secured the necessary conditions. If this advice is intelligently followed by your readers, we shall have less complaints of failures in toning trials; and, in conclusion, I would urge on those desponding ones to persevere, for those who prescribe remedies acquire their knowledge by passing through the same ordeal of difficulties.

In conclusion I would apologise for the lengthened remarks which were suggested by your ably-written article on lime toning, and add that, when time will permit, I intend entering on the causes of success and failures in general, where photographic printing is concerned.

[Our contributor being very anxious to assist his photographic brethren in their toning troubles, has undertaken to test any sample of paper with which our readers, using his modified formula, may fail in getting good results. Address to him under cover to us.—Ed.]

PHOTERGIMETRY.

BY SIG. GARNERI, OF TURIN.

The photergimeter is an instrument intended to measure with precision the degree of intensity of the chemical action of light. It is constructed as follows:—Some positive paper is prepared upon concentrated baths of definite strength, the one, a solution of sal ammoniac at 10 per cent., the other a solution of nitrate of silver of 30 per cent. Next take a band of this paper, and cover it with a card, and expose it gradually to light by uncovering, successively, a portion at intervals of half a minute; lastly they are toned and fixed, and form the photergimetric scale.

When it is wished to make an observation, a band of the paper, prepared upon similar baths to those which have served for the preparation of the type band, is placed by the side of the scale; the instrument is carried to the place where we wish to examine the light, then count *five minutes*. At the expiration of this time the paper has acquired a tint which corresponds to one of the 20 gradations of the scale; we can then say that the light is of such and such a degree of the photergimeter, just as we say that heat is at such or such a degree of the thermometer.

To quote only a single example of the utility of this instrument, let us say that it often occurs to photographers, even the most experienced, not to know the exact time of exposure to give in cloudy weather, when the light may be said to be doubtful. Now it will be very easy for them, by comparing the indications of this instrument two or three times with the effects of their objectives, to have a sure guide under all circumstances.

The photergimetric scale should be placed in a portfolio contrived to hold bands prepared for experiments; we can keep a stock of these bands a long time when enclosed in a bottle containing chloride of calcium.—*Bulletin Chimique*.

ON MALIC AND MALEIC ACIDS AS NEW ISOMERIC BODIES.

BY H. KAMMERER.

We employ in photography a liquid containing nitrate of silver and sugar of milk, in which papers impregnated with succinic acid, citric acid, or other substances, are immersed. After prolonged use, there is deposited in such a liquid crystals of a silver compound, the composition of which is

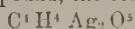

This salt is isomeric with malate of silver. Its acid, which the author calls *isomalic acid*, is obtained by decomposing the salt of silver by sulphuretted hydrogen. It is crystallizable, forming colourless, transparent crystals, belonging to the oblique rhomboidal prism system. It is bibasic, like malic acid, but its salts are different from the malates. Acid isomalate of ammonia is obtained by saturating the acid with ammonia, by evaporation, one part of the ammonia is disengaged, and a radiated crystalline mass remains, the composition of which may be expressed by the following formula:—



The neutral salt of potassa $C^4 H^4 K^2 O^5 + H^2 O$ forms lamellar monoclinic crystals.

The neutral salt of lead is wholly insoluble in water and does not dissolve in boiling water. The salt of silver forms a white precipitate, flocculent at first, insoluble in water, but which, heated with water, is transformed into microscopic hexagonal plates. This salt is fixed at 212° , which distinguishes it from the two known malic acids.

The salt of silver treated with iodide of ethyl gives the ether $C^4 H^4 (C^2 H^5)_2 O^5$.

This body forms a liquid more dense than water which dissolves and decomposes it. The author has not obtained the amide.

The isomalates, treated by perchloride of phosphorous, furnish a chloride isomeric with chloride of fumaryl, which has been obtained from the malates. It is a yellow liquid of a penetrating and suffocating odour. It cannot be distilled without decomposition, and the water gradually decomposes it into hydrochloric acid and *isomaleic acid*, isomeric with fumaric and maleic acids. *Isomaleic acid* is bibasic; it is more soluble in water than fumaric acid is, but less so than maleic acid. Its composition is represented by the formula:—



Its potassa salt is deliquescent; the sulphate of lead forms a flocculent amorphous precipitate; the salt of silver is soluble in water, and by ebullition gives a metallic mirror.

The formation of the isomalic acid may be due to the oxydation of the succinic acid gradually formed in the liquid,

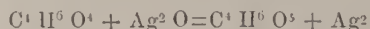

but, in this case, it ought to be identical with the acid obtained by M. Kébulé with bromo-succinic acid, from which, on the contrary, it differs. It is more probable that the isomalic acid is formed by oxydation of the sugar of milk.

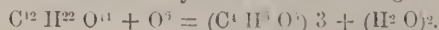

—*Bulletin de la Société Chimique de Paris.*

ON THE COMPOSITION OF THE PHOTOGRAPHIC PICTURE.

BY EUGENE SAHLER.

The following experiments, to which I have been led by the theoretical hypothesis I published in May, 1862, which was repeated and commented upon by many theorists and operators who have more skill and leisure than I can boast of, may perhaps throw some light upon the subject of the

photographic image, and so contribute to the progress of the art.

1st Experiment.—I have washed in several waters a collodion plate sensitized in the usual manner so as to completely remove the excess of nitrate of silver. I afterwards immersed the plate in a saturated and filtered solution of binocide of barium.

During exposure I filled the camera with the fumes of hydrochloric acid, so as to place the film of iodide of silver in contact with oxygenated water.

The plate, when withdrawn, exhibited the usual opaline hue, without any trace of a picture.

To develop it with sulphate of protoxide of iron, it was first washed, else there would have been a formation of precipitated sulphate of barytes. The developing solution, then poured on to the plate, did not change its colour, and no picture made its appearance. After another washing I immersed the plate in the silver bath, and, at the end of a minute, I again submitted it to the action of the developer. The effect was immediate, the whole film blackened vigorously, and the picture, invisible by transmitted light, was clearly displayed by reflected light.

2nd Experiment.—To moderate the effect of the oxygenated water, I operated as described above, and diluted the bath of binocide of barium, exposed for twenty seconds, filling the camera with carbonic acid gas.

The plate, washed and immersed in a bath of nitrate of silver, strength 3 per cent., yielded a good picture; a slight reduction appeared over the entire plate.

In these two experiments, the film, composed only of oxy-iodide of silver, had not changed its aspect, and the developer alone had no action upon it. The striking analogy this case presents with the ordinary reaction, appears to me to merit serious attention.

My conclusion is, that the disturbance caused by light is rather a chemical combination, and that in the production of the picture, oxy-iodide of silver is formed.

A well known chemical observation had previously led me to adopt the hypothesis of oxydation: it is this:—*Chloride of silver, treated with warm nitric acid, does not produce aqua regia, as the other chlorides do, because, in presence of energetic oxydizers, it does not part with the chlorine, and there can only be a formation of oxy-chloride.*

The results obtained in the dry process, especially, seem to confirm this opinion, which, in fact, are the substances that succeed the best?

1. Resins and tannin, bodies which slowly absorb oxygen, an absorption which facilitates the oxydation of the sensitive film.

2. Albumen, which has an alkaline reaction; the alkalies and alkaline salts, which, in contact with the sensitive film, form double salts more easily oxydizable, as even the water of the bath can decompose them by losing its oxygen—a reaction so well known, that it has caused the rejection of alkaline baths, which veil the pictures.

3rd Experiment.—I next poured upon the sensitized plate a mixture of a small quantity of the sensitizing bath, with a few drops of the saturated solution of binocide of barium, the liquid remained clear. With a short exposure, the iron developer gave me an excellent negative. In this instance I washed the plate after exposure, and afterwards immersed it in the silver bath.

It is to be observed that the two oxydizers I have employed, the chlorate of potassa, in presence of nitric acid, and the binocide of barium, give such a solidity to the collodion film that varnishing may be dispensed with.—*Revue Photographique.*

DOINGS OF THE SUNBEAM.*

It is a relief to soar away from the contemplation of those sad scenes, and fly in the balloon which carried Messrs. King

Continued from page 382.

and Black in their aerial photographic excursion. Our townsman, Dr. John Jeffries, as is well recollected, was one of the first to tempt the perilous heights of the atmosphere, and the first who ever performed a journey through the air of any considerable extent. We believe this attempt of our younger townsman to be the earliest in which the aeronaut has sought to work the two miracles at once—of rising against the force of gravity, and picturing the face of the earth beneath him without brush or pencil.

One of their photographs is lying before us. Boston, as the eagle and the wild goose see it, is a very different object from the same place as the solid citizen looks up at its caves and chimneys. The Old South and Trinity Church are two landmarks not to be mistaken. Washington Street slants across the picture as a narrow cleft. Milk Street winds as if the cow-path which gave it a name had been followed by the builders of its commercial palaces. Windows, chimneys, and skylights attract the eye in the central parts of the view, exquisitely defined, bewildering in numbers. Towards the circumference it grows darker, becoming elongated and confused, and at one end a black expanse of waveless water is whitened by the nebulous outline of flitting sails. As a first attempt it is, on the whole, a remarkable success; but its greatest interest is in showing what we may hope to see accomplished in the same direction.

While the aeronaut is looking at our planet from the vault of heaven, where he hangs suspended, and seizing the image of the scene beneath him as he flies, the astronomer is causing the heavenly bodies to print their images on the sensitive sheet he spreads under the rays concentrated by his telescope. We have formerly taken occasion to speak of the wonderful stereoscopic figures of the moon taken by Mr. De la Rue, in England, by Mr. Rutherford, and by Mr. Whipple, in this country. To these most successful experiments must be added that of Dr. Henry Draper, who has constructed a reflecting telescope, with the largest silver reflector in the world, except that of the Imperial Observatory, at Paris, for the special purpose of celestial photography. The reflectors made by Dr. Draper "will show Debilissima quadruple, and easily bring out the companion of Sirius or the sixth star in the trapezium of Orion." In taking photographs from these mirrors, a movement of the sensitive plate of only one-hundredth of an inch will render the image perceptibly less sharp. It was this accuracy of convergence of the light which led Dr. Draper to prefer the mirror to the achromatic lens. He has taken almost all the daily phases of the moon, from the sixth to the twenty-seventh day, using mostly some of Mr. Anthony's quick collodion, and has repeatedly obtained the full moon by means of it in *one-third of a second*.

In the last *Annual of Scientific Discovery* are interesting notices of photographs of the sun, showing the spots on his disc, of Jupiter with his belts, and Saturn with his ring.

While the astronomer has been reducing the heavenly bodies to the dimension of his stereoscopic slide, the anatomist has been lifting the invisible by the aid of his microscope into palpable dimensions, to remain permanently recorded in the handwriting of the sun himself. Eighteen years ago, M. Donné published in Paris a series of plates executed after figures obtained by the process of Daguerre. These, which we have long employed in teaching, give some pretty good views of various organic elements, but do not attempt to reproduce any of the tissues. Professor O. N. Rood, of Troy, has sent us some most interesting photographs, showing the markings of infusoria enormously magnified and perfectly defined. In a stereograph sent us by the same gentleman the epithelium scales from mucous membrane are shown floating or half submerged in fluid—a very curious effect, requiring the double image to produce it. Of all the microphotographs we have seen, those made by Dr. John Dean, of Boston, from his own sections of the spinal cord, are the most remarkable for the light they throw on the minute structure of the body. The sections made by Dr. Dean are in themselves very beautiful specimens, and have formed the basis of a communication to the American Academy of Arts and Sciences, in which many new observations have been added to our knowledge of this most complicated structure. But figures drawn from images seen in the field of the microscope have too often been known to borrow a good deal from the imagination of the beholder. Some objects are so complex that they defy the most cunning hand to render them with all their features. When the enlarged image is suffered to delineate itself, as in Dr. Dean's views of the *medulla oblongata*, there is no room to question the

exactness of the portraiture, and the distant student is able to form his own opinion as well as the original observer. These later achievements of Dr. Dean have excited much attention here and in Europe, and point to a new epoch of anatomical and physiological delineation.

The reversed method of microscopic photography is that which gives portraits and documents in little. The best specimen of this kind we have obtained is another of those miracles which recall the wonders of Arabian fiction. On a slip of glass, three inches long by one broad, is a circle of thinner glass, as large as a ten-cent piece. In the centre of this is a speck, as if a fly had stepped there without scraping his foot before setting it down. On putting this under a microscope magnifying fifty diameters there come into view the Declaration of Independence in full, in a clear, bold type, every name signed in fac-simile; the arms of all the States, easily made out, and well finished; with good portraits of all the Presidents, down to a recent date. Any person familiar with the faces of the Presidents would recognize any one of these portraits in a moment.

Still another application of photography, becoming every day more and more familiar to the public, is that which produces enlarged portraits, even life-size ones, from the old daguerreotype or more recent photographic miniature. As we have seen this process, a closet is arranged as a camera obscura, and the enlarged image is thrown down through a lens above on a sheet of sensitive paper placed on a table capable of being easily elevated or depressed. The image, weakened by diffusion over so large a space, prints itself slowly, but at last comes out with a clearness which is surprising—a fact which is parallel to what is observed in the stereopticon, where a picture of a few square inches in size is "extended" or diluted so as to cover some hundreds of square feet, and yet preserves its sharpness to a degree which seems incredible.

The copying of documents to be used as evidence is another most important application of photography. No scribe, however skilful, could reproduce such a paper as we saw submitted to our fellow-workman in Mr. Black's establishment the other day. It contained, perhaps, a hundred names and marks, but smeared, spotted, soiled, rubbed, and showing every awkward shape of penmanship that a miscellaneous collection of half educated persons could furnish. No one, on looking at the photographic copy, could doubt that it was a genuine reproduction of a real list of signatures; and when half a dozen such copies, all just alike, were shown, the conviction became a certainty that all had a common origin. This copy was made with a *Harrison's globe lens* of sixteen inches' focal length, and was a very sharp and accurate duplicate of the original. It is claimed for this new American invention that it is quite "ahead of anything European;" and the certificates from the United States Coast Survey Office go far towards sustaining its pretensions.

Some of our readers are aware that photographic operations are not confined to the delineation of material objects. There are certain establishments in which, for an extra consideration, (on account of the *difficilis ascensus*, or other long journey they have to take,) the spirits of the departed appear in the same picture which gives the surviving friends. The actinic influence of a ghost on a sensitive plate is not so strong as might be desired; but considering that spirits are so nearly immaterial that the stars, as Ossian tells us, can be seen through their vaporous outlines, the effect is perhaps as good as ought to be expected.

Mrs. Brown, for instance, has lost her infant, and wishes to have its spirit portrait taken with her own. A special sitting is granted, and a special fee is paid. In duo tunc the photograph is ready, and sure enough, there is the misty image of an infant in the background, or it may be, across the mother's lap. Whether the original of the image was a month or a year old, whether it belonged to Mrs. Brown, or Mrs. Jones, or Mrs. Robinson, King Solomon, who could point out so sagaciously the parentage of unauthenticated babies, would be puzzled to guess. But it is enough for the poor mother, whose eyes are blinded with tears, that she sees a print of drapery like an infant's dress, and a rounded something like a foggy dumpling, which will stand for a face; she accepts the spirit portrait as a revelation from the world of shadows. Those who have seen shapes in the clouds, or remember Hamlet and Polonius, or who have noticed how readily untaught eyes see a portrait of parent, spouse, or child, in almost any daub intended for the same, will understand how easily the weak people who resort to these places are deluded.

There are various ways of producing these spirit photographs. One of the easiest is this. First procure a bereaved subject with a mind "sensitized" by long immersion in credulity. Find out the age, sex, and whatever else you can, about his or her departed relative. Select from your numerous negatives one that corresponds to the late lamented as nearly as may be. Prepare a sensitive plate. Now place the negative against it and hold it up close to your gas lamp, which may be turned up pretty high. In this way you get a foggy copy of the negative in one part of the sensitive plate, which you can then place in the camera and take your flesh and blood sitter's portrait upon it in the usual way. An appropriate background for these pictures is a view of the asylum for feeble-minded persons, the group of buildings at Somerville, and, possibly, if the penitentiary could be introduced, the hint would be salutary.

The number of amateur artists in photography is continually increasing. The interest we ourselves have taken in some results of photographic art has brought us under a weight of obligation to many of them, which we can hardly expect to discharge. Some of the friends in our immediate neighbourhood have sent us photographs of their own making, which, for beauty and clearness of tone, compare favourably with the best professional work. Among our more distant correspondents there are two so widely known to photographers that we need not hesitate to name them: Mr. Coleman Sellers, of Philadelphia, and Mr. S. Wager Hull, of New York. Many beautiful specimens of photographic art have been sent us by these gentlemen,—among others, some exquisite views of Sunnyside, and of the scene of Ichabod Crane's adventures. Mr. Hull, has also furnished us with a full account of the dry process, as followed by him, and from which he brings out results hardly surpassed by any method.

A photographic intimacy between two persons who never saw each other's faces (that is, in Nature's original positive, the principal use of which, after all, is to furnish negatives from which portraits may be taken) is a new form of friendship. After an introduction by means of a few views of scenery or other impersonal objects, with a letter or two of explanation, the artist sends his own presentment, not in the stiff shape of a purchased *carte de visite*, but as seen in his own study or parlour, surrounded by the domestic accidents which add to the individuality of the student or the artist. You see him at his desk or table with his books and stereoscopes round him; you notice the lamp by which he reads,—the objects lying about; you guess his condition, whether married or single; you divine his tastes, apart from that which he has in common with yourself. By-and-by, as he warms towards you, he sends you the picture of what lies next to his heart,—a lovely boy, for instance, such as laughs upon us in the delicious portrait on which we are now looking, or an old homestead, fragrant with all the roses of his dead summers, caught in one of Nature's loving moments, with the sunshine gilding it like the light of his own memory. And so these shadows have made him with his outer and his inner life a reality for you; and but for his voice, which you have never heard, you know him better than hundreds who call him by name, as they meet him year after year, and reckon him among their familiar acquaintances.

To all these friends of ours, those whom we have named, and not less those whom we have silently remembered, we send our grateful acknowledgements. They have never allowed the interest we have long taken in the miraculous art of photography to slacken. Though not one of them may learn anything from this simple account we have given, they will perhaps allow that it has a certain value for less instructed readers, in consequence of its numerous and rich omissions of much, which, however valuable, is not at first indispensable.

COPYRIGHT IN WORKS OF FINE ART.

THE new Copyright Act, passed last Session, has not given universal satisfaction, as not being sufficiently comprehensive in its objects, or specific and clear in its bearing on some points. Some remarks by a correspondent of the *Athenaeum*, and comments thereon by the Editor, will be interesting to photographers. The correspondent, Mr. F. W. Campin, says:—

Mr. Black, M.P., having given notice in the House of Commons of his intention to move in the next Session of Parliament that a measure be allowed to be introduced by him to consoli-

date and amend our Copyright Law (some remarks as to which I not long since communicated to you), I have forwarded the following suggestions on the subject for his consideration; and as they are, I submit, worthy of discussion, I venture to hope you may find a place for them in your columns. 1st. It appears to me there should be but one Copyright Act regulating copyright in all literary productions, in paintings, engravings, etchings, lithographs, &c., in sculpture, carvings, artistic casts and designs, in photographs and all original artistic productions; also in *architectural designs*. 2nd. That a simple and cheap registration, at Stationers' Hall, or otherwise, such as that now required by the Literary Copyright or Serjeant Talfourd's Act and the Artistic Copyright Acts, should be required; the effect of this registration should, as under those Acts, give the right to claim and sue for damages or penalties for all *subsequent* invasions of the copyright. Non-registration not to affect the copyright, but only the right of instituting legal proceedings in regard thereto. 3rd. The right to dramatise or versify (or to turn any drama into narrative, novel or otherwise, or a poetical production into prose), as regards any original literary production, should be reserved to the author if he announces his intention to reserve those rights, which he might do in a similar manner as he can now announce his intention to reserve the right of translation). These rights, like the rights of translation under the International Copyright Law, to be forfeited if the work be not dramatised or versified within a restricted period. 4th. If artistic designs are to be applied to articles of utility and manufacture, such, for instance and illustration, as drinking-vessels, articles of domestic or personal use, &c., then an additional registration under the Acts for Protecting Designs for Ornamenting Articles of Manufacture should be required. 5th. Fac-simile representations (or nearly fac-simile representations) of persons or of things, natural or artificial, produced by the use of photographic apparatus or other means of producing such representations, should have a copyright for a very short term only; for it can scarcely be maintained that the production of such representations involves the exercise of authorship, and I submit that there can scarcely be a true basis for copyright without authorship. It will become a crying grievance if a photographic manipulator can, by being the first in the field, secure the copyright in mere representations of the portraits of our public characters, and our most pleasing landscapes. 6th. With regard to *architectural designs*, the right to build according to any copyright design should be subject to be reserved to the author or designer in the same way and upon the same conditions that I have proposed with regard to the dramatising or versifying of literary works, in order to provide that if the originator of the design does not build within a restricted period, he shall not then prevent any one else doing so: his copyright in other respects, however, to remain intact.

In a following number the Editor makes the following comments:—

In Mr. F. W. Campin's communication to us on Copyright Amendment, as to *Photographs*, he says, "It will become a crying grievance if a photographic manipulator can, by being the first in the field, secure the copyright in mere representations of the portraits of our public characters and our most pleasing landscapes." No doubt, if such were the law, it would be a serious mischief; but the fact is, that no copyright exists in the *subject* of any work of Art. For example, if B executes a photographic or any other description of portrait of Lord Palmerston, all the copyright that B could possibly acquire in his work would be the right of preventing copies of that work being made without his permission. But that will not preclude any other artist from also taking a portrait of Lord Palmerston, and acquiring a copyright in his work, *provided only he has not copied that previously executed by B*. An indefinite number of copyrights may thus be acquired in the same *subject*. The Copyright Works of Art Act, 1862, which for the first time gave copyright in "every *original* painting, drawing, and photograph," by section 2, expressly provides that nothing in that Act contained "shall prejudice the right of any person to copy or use any work in which there shall be no copyright, or to represent any scene or object, notwithstanding that there may be copyright in some representations of such scene or object." The same principle equally applies to all works of literature and of music. The *subject* which an author selects is public property; and each author who writes or composes a

work upon that subject may acquire a valid copyright in his work, subject only to the condition that it is his own original production and not a mere copy or colourable imitation of the work of another person. As to the *title* which an author may adopt upon the publication of his work, he does, in most instances, acquire a priority over every other author or composer of a work upon the same subject; but only to such an extent as may be needful to prevent the public from being misled by supposing they are purchasing the work of A whereas they are buying that of B, who would thus unfairly intercept the profits which ought to accrue to A from his copyright.

Recent Patents.

A NEW PROCESS OF OBTAINING PRINTING SURFACES, DIES AND SUBSTITUTES FOR PHOTOGRAPHIC NEGATIVES. A communication from PAUL SCHULZE AND FREDERICK W. BILLING, of Brooklyn U. S.

The objects of this invention are, first, to procure a cheap substitute for wood engraving, from which to obtain, by the electrotype process, surfaces which can be printed from in the same manner as electrotypes obtained from wood engravings.

Second, to enable the process of etching metal surfaces to be performed more easily than by the mode heretofore produced.

Third, to obtain an easy mode of making dies for seals or for stamps of a similar character.

Fourth, to obtain by drawing, without the aid of a camera, or the agency of light, substitutes for photographic negatives, which may be printed from in the same manner as those negatives by the action of light acting through them upon sensitive paper.

The principal feature of the invention consists in first making a drawing in ink, which is soluble in water, upon the surface of a plate of glass or any other hard substance which has been previously coated with an alcoholic solution of shellac; then covering the whole surface with a coating of beeswax, or of a composition of beeswax, asphaltum and linseed oil, or other menstruum; next, immersing the plate in water for some time, and afterwards exposing its face to the action of a stream of water, by which the latter coating is washed off only from the lines of the drawing, and the whole of the drawing itself is washed away, leaving the latter coating between and among the lines of the drawing. The plate in this condition can be used in the same manner as a wood engraving to obtain an electrotype for printing, and with very little subsequent preparation for the other purposes herein above specified, as will be presently described.

In order to obtain the substitute for wood engraving, the plate of glass or other hard substance intended to receive the drawing should be made even, and have a fine grain given it by grinding with fine sand, rotten stone, or other suitable material. The first coating or ground of shellac solution may be applied either by pouring it over the surface, or by rubbing it on with a piece of cloth, and when it is dry it is ready for the drawing. The ink with which the drawing is made may be composed of a solution of gum arabic in water with enough sugar to prevent it from cracking off or separating from the plate when dry, and a suitable quantity of ivory black, lampblack, or any other colouring matter to make the drawing appear; or it may be composed of a weak solution of glue water, with any colouring matter, or of any coloured pasty substance soluble in water. The drawing may be made with a pen, brush, or pencil dipped in such ink. When the drawing has been completed, the second coating can be applied. It is preferred to use for this coating a composition of four parts by weight of beeswax, one part asphaltum, and one part rosin, with as much thin varnish, such as is used by printers for thinning their ink, or linseed oil, as will render the composition applicable with a lithographic inking roller or engravers' daub. The same end can be obtained with a coating of beeswax softened with spirits of turpentine, but with less sharp and clear lines. The necessary thickness of the coating will depend upon the character of the drawing, a thinner coating being sufficient for close fine work. After the application of this coating the plate is to be immersed in water. If the coating is thin, fifteen minutes immersion will be sufficient, but a proportionally longer time will be necessary for a thicker coating.

On the plate being removed from the water bath a stream of water is to be directed upon its face, and by that means the last coating is removed from the lines of the drawing, and the ink of the drawing all washed out, leaving the coating perfect between the lines of and around the drawing. In most cases the coating will remain sufficiently high to enable a good electrotype for printing to be taken from it; but when a higher ground is needed it can be produced by dusting lycopodium on the surface with a soft brush. Where the composition remains on the plate the lycopodium will unite with it, and by applying more of the composition over the surface with an inking roller, the lycopodium will be removed from the lines of the drawing, and the surface of the coating of composition will be further raised. Broad spaces between the lines, where a higher ground is necessary, can be raised by applying beeswax in the same manner as electrotypes now apply it to the surfaces of wood engravings, or by applying asphaltum with a brush. Before the plate is put into the hands of the electrotyper a thin coat of alcoholic varnish or linseed oil is poured on to it that the varnish or linseed oil in the ground may not prevent the deposit of the copper, and this coat of varnish will ensure the plumbago applied by the electrotyper being received and retained on every portion of the surface of the plates. In this way a substitute for wood engravings is obtained in a very short time at a small cost.

Instead of the drawing being made upon a plate, it may be made upon paper which has been first thoroughly saturated with alcoholic varnish, or any other substance, such as wax, that will make it perfectly waterproof; and after the drawing has been made, the back of the paper should be cemented to the surface of a perfectly flat plate, with beeswax or some other waterproof cement, and afterwards treated in the same manner as before described.

For metal etching the drawing is made with the soluble ink, in the manner above described, on the surface of the metal, and after it has been completed the whole surface of the plate is coated either with the etching ground commonly used by engravers, or with a ground of beeswax applied while the plate is warm, instead of with the second coating, which is applied to obtain the substitute for wood engraving, as hereinbefore described. The plate is then immersed in water, and afterwards exposed to the action of a stream of water directed upon its face to wash out the drawing, as hereinbefore mentioned, and the plate is ready to receive the acid for etching.

For making dies for seals or stamps of similar character, a drawing is made as at first described, and subjected to the same treatment up to the filling in of the broad spaces between the lines with beeswax or asphaltum, when it can be used as the mould from which to obtain a die in which to produce a seal by casting.

To obtain a substitute for photographic negatives, a drawing is made in the manner hereinbefore described, on a plate of finely ground glass, and after it has been made, instead of being coated with the beeswax, or composition of beeswax, asphaltum, and rosin, hereinbefore specified, a thin coating of that composition, with which some fine lampblack has been mixed, is applied. The plate is then subjected to the soaking and washing operations to remove the ink, and when it has dried it is dusted over with lampblack, by means of a fine brush, to make the ground still less transparent; after which the whole surface has applied to it a coat of alcoholic varnish. When this varnish is dry, the plate is used for printing upon prepared paper in the same manner as a photographic negative obtained by the camera. The drawings for etching seals and photographs have to be reversed, but for the first described purpose they should not be reversed.

Correspondence.

FOREIGN SCIENCE.

[FROM OUR SPECIAL CORRESPONDENT.]

Paris, August 11th, 1863.

At a recent meeting of our Society, M. Liébert, of San Francisco, offered some remarks upon the processes employed in the United States of North America to obtain ordinary or enlarged proofs. His communication referred especially to the following subjects:—

1. The suppression of tripoli, rotten stone, &c., in cleaning glass plates. These powders are advantageously superseded by a simple roll of china paper moistened with alcohol.

2. A small, simple, and convenient apparatus to hold the plates while being cleaned.

3. The complete restoration of the decomposed silver baths by the conversion of the nitrate of silver into bi-carbonate of silver, precipitated and re-dissolved without excess by nitric acid.

4. Direct positives upon thin iron plates, covered with Japanese varnish (Chinese lacquer), serving admirably for medallions, as these plates may be cut with chisels, and may be sent conveniently in a letter. These proofs have great delicacy, and are easily finished in a few minutes. The process is the same as for positives on glass.

5. Negative developing baths, giving also, immediately, the desired intensity without crude or harsh tones. This re-agent, on the contrary, gives great delicacy, and renders the model very vigorously. It is obtained in the following manner:—

Dissolve together

Sulphate of protoxide of iron	...	1 ounce
Nitrate of Potassia	...	¼ ounce

In

Rain or river water	...	14 ounces
---------------------	-----	-----------

Add

Pyroligneous acid	...	1 ounce
Alcohol, at 32°	...	¼ ounce
Silver bath solution, at 10 per cent.	...	½ ounce

Filter.

The collodion must be appropriate by being iodized with the re-agent indicated.

6. Toning proofs on albumenized paper with neutral salts of gold.

Solution No. 1.

Distilled water	...	20 ounces
Chloride of gold	...	30 grains.

Solution No. 2.

Distilled water	...	20 ounces
Bicarbonat of soda	...	120 grains.

Into ten ounces of distilled water put one ounce of the solution No. 1, and one ounce of solution No. 2. The proofs previously washed are immersed in this bath, and allowed to remain until they have acquired a blue-black colour, which takes place in four or five minutes upon moving the proof about in the bath; the toning being stopped by washing, the proof is washed and fixed in new plain hyposulphite of soda.

7. Toning with nitrate of uranium.

Solution No. 1.

Chloride of gold	...	15 grains
Distilled water	...	2 ounces.

Neutralize with bicarbonate of soda.

Solution No. 2.

Acetate of soda	...	100 grains
Water	...	32 ounces.

Solution No. 3.

Nitrate of uranium	...	15 grains
Distilled water	...	2 ounces.

Neutralize with bicarbonate of soda.

Mix and filter.

The proofs treated in these toning baths have remarkable vigour and warmth of tone.

Transfer the proof to waxed paper, or, which is better, coat it with a solution of caoutchouc; the proof finished and dried as though it were to remain upon the glass, is easily detached by a solution of

Alcohol (32°)	...	1 ounce
Nitric acid	...	10 drops.

which is left in the picture for about one or two minutes.

8. Photographic paper of extreme sensibility for direct

enlarged portraits upon chloride of silver, is obtained by a bath of acidulated ammonio-nitrate. The proofs are toned and fixed, and possess remarkable vigour.

9. A simplified and improved solar instrument, without reflector, which permits of the printing of proofs of very large dimensions, with perfect sharpness, and in a space of time one-fourth of that required by the French uegascope.

The instrument consists of a wooden box mounted upon a turning support, which permits of our continually keeping the sun upon the concentrating lens which projects the beam of light upon the negative, to afterwards design the picture upon the sensitized paper, which is at the end of the apparatus.

AN ENGLISH AMATEUR'S GLANCE AT FRENCH PHOTOGRAPHY.

SIR,—Arrived in Paris, my first visit was to the Quai de l'Horloge, the local habitation of most of the Parisian opticians, not forgetting Mons. Chevalier, I think in the Quai or Rue des Orfevres, and who most kindly directed and helped me to discover the whereabouts of one or two parties engaged in mounting choice microscopic objects. Curiously enough, the hotel to which I was bound was the Brittanique, the same at which you stopped; and I must say that I was well and reasonably treated. Never did a day pass by but I scrutinised the photographic productions, and cannot say that in all the length or breadth of the city did I see any downright bad pictures, or any touting abominations as I fear are too rife here. The even goodness struck me most forcibly; the large whole and half plate pictures seemed remarkably good, and the absence in the small carte de visite pictures of the multitudinous accessories here employed, but which were filled up by skill in posing, no one could pass unnoticed. Another fact appeared to be that the figures on the carte de visite were smaller than with us, and I also noticed that they appear to repudiate the use of very highly albumenized paper. This latter, I think, is a great step; since my return I have pointed it out to many of my photographic friends, and have obtained a supply of Marion's paper, which seems identical to that used in Paris, and with the phosphate of soda formula—

Soda phosphate	...	2 grs.
Chloride of gold	...	1 gr.
Water	...	8 ozs.

—the best pictures they have ever turned out have resulted.

Do you know how the peculiar pinkish hue (*nothing allied to red*) is obtained; several are shown, and very pleasing they were?

Already do I see that you have anticipated all I could say as to the pictures by Disderi, Numa Blanc, Ken, Petit, &c., and your lucid description of how the photographic sculpture statuettes which I saw at Bisson Frères' in, I think, the Quai d'Orsai, has done away with the apparent difficulty of chiselling by light. As the science, however, has arisen with M. Wilkeme, who must be a first class sculptor, and in whom the fact of making the resemblance lies, think you that the art will become general? Of course the Louvre must be seen, and here I saw an easel, the principle of which might be adapted to our wants as regards something suitable where copying is requisite. I am somewhat rough as a draughtsman, but here it is, such as it is.

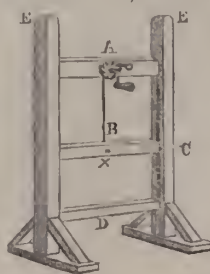

E E are two upright posts with broad wooden bases. At A and D two cross bars are fixed at either end into the aforesaid uprights, between the cross pieces A and D, and in the uprights, a groove (*à la guillotine*) is made in which works a sliding bar, B, which at the back has a staple through which passes a cord knotted at X. At A is a ratchet wheel and catch, round which goes the other end of the cord of course; on B there

is a ledge, and it can be heightened or lowered as required. Now, if in addition to this a plank was extended from B, having at its other end two telescopic legs, we should have an apparatus at right angles to the print to be copied; and, with a short level and the legs, all could be brought into a plane. From inquiries I made, I was told they were very cheap and easily obtainable in London. Doubtless some of the drawing material houses may have the article.

Half a day next at the Palais d'Industrie, and the Photographic Exhibition for half a franc (five pence), and very cheap too, considering the many (I had almost said all), good Photographs there exhibited. A good deal, I think, I had seen over here, but for a specimen of photo-micrography, "The Flea," by A. Dunelle, No. 1102, must, I think, stand pre-eminent of its kind. I should say it must have measured at least from end to end three feet. The coloured glasses in the stereoscopes, were pleasing in some instances, but the effect struck me as being somewhat too abrupt.

When we see such magnificent landscapes as abound just outside Paris, is it not wonderful that this branch of photography appears to be the exception and not the rule. I am sure that the view of Sevres from the railway—I think the *rive gauche* of the Western Railway—would carry off the palm at any exhibition. Perhaps it has already been done, and my very pleasing remembrance of Versailles may have carried me beside myself. I cannot conclude my long letter without saying that the eight days I spent there were the most delightful I ever passed amongst strangers. I met with the greatest cordiality. I do not remember an instance in which I was imposed upon; and whenever (which was very frequent) I lost my way, and had occasion to inquire, the trouble and pains that were taken far exceed belief.

With an *au revoir* to Paris, believe me, my dear sir, yours very truly,
 JOHN BOCKETT.
 10, Willingham Terrace, Kentish Town, July 30th, 1863.

CUMULATIVE EFFECTS IN PHOTOGRAPHY.

SIR,—Photography is supposed by some to be perfect in itself. One glance of the lens at an object, one application of the sensitive coating, and one development is all that is considered necessary to produce a perfect negative, and, following up the same rule, one coating of the paper, and one exposure of it under one negative is believed by many the only course to pursue to procure a perfect photographic print. To these assumptions I demur, and I refer to Nature for the proof. All beautiful things in nature are produced by degrees, a certain effect is repeated, sunshine and darkness, moisture and drought, heat and cold, succeed each other, repeating their effects until the fruit and the flowers become matured. In like manner we should proceed to obtain a natural photographic representation of an object. The better to illustrate my meaning, I would refer you to the "Photo-Automaton Register," in my specification No. 1936, 3rd August, 1861, by which instrument several negatives can be taken of the same subject with varying degrees of exposure, but so placed that each will shut down in perfect register together. The subject may be landscape or the figure, the operation is the same. I take the negative that has been most exposed, shutting it down first on the prepared paper; I next change it for one less exposed, and, lastly, I apply the one that has been least exposed, and which may only show tops of trees, chimneys, or the tints in the folds of white dresses or clouds, until all are truthfully printed. The effect of such a course is to produce a print which for roundness rivals the stereoscope, and supplies the only means of getting the details of strongly contrasted subjects by the direct agency of light itself, avoiding the rude and imperfect attempts of hand-touching.—Your obedient servant,
 JOSEPH LEWIS.

29, Dame Street, Dublin, 1st August, 1863.

FORMULA FOR THE DETERMINATION OF THE COMPARATIVE DURATION OF EXPOSURE OF A SENSITIZED SURFACE IN THE CAMERA.

LET A represent the area of the aperture of the lens, F the focal length, and E the duration of exposure of a given surface, ascertained by experiment, and let A, or F, or both, be varied—required, the value of E, the amount of variation of A F being known.

Let *a f e* represent the variation of A F E.

$A + F$ gives the result E.

$$\frac{A E}{a} \text{ gives } x.$$

x here denoting the duration of exposure when F is invariable.

$$\frac{f^2 x}{F^2} \text{ gives } e.$$

e denoting the duration of exposure when A and F are variable, or *a + f* gives the result *e*.

Example of the application of this Formula.

Required the amount of exposure of a collodion surface, with 1 in. diameter aperture lens, 8 in. focus, it being known that with $\frac{1}{2}$ in. diameter aperture, lens of 6 in. focus (measured in each case from the back of the lens to the surface of focussing glass) required 30 seconds?

$$\frac{.196 \cdot 30}{.7845} \text{ gives } 7.45$$

$$\frac{64 \cdot 7.45}{.36} \text{ gives } 13.24, \text{ or } 13\frac{1}{4} \text{ seconds nearly.}$$

T. W. T.

[The formula is correct, although, perhaps, a little unnecessarily complicated; but it will be entirely vitiated if calculations are based on the "back focus," which is of no value for such calculations. The equivalent focus must always be ascertained, as it is the relation of aperture to equivalent focus which determines the amount of light.—Ed.]

Photographic Notes and Queries.

GLASS FOR DARK ROOMS.

SIR,—Most photographers are quite aware of the amount of gossip that there has been going on respecting non-actinic glass; but I have no doubt that few are aware that a window, say, 61 x 36, can be made perfectly impervious to the chemical ray for about 1s. 6d., in the following manner:—Say, for a light the size above named, go to an artists' colourman and get two tubes of raw sienna, and the same of orange chromic No. 3; mix them together, thin down to the usual consistency of ordinary oil colour with gold size (Japanese) and turpentine, and a small bit of patent driers; paint your window with it two or three times, carefully, and you will be charmed to see the beautiful golden tint it presents, and I may add that those who have been accustomed to work with a hole about 18 inches square, will, if they can command an ordinary sash window, do as I have done, will fancy themselves, not in a "dark room," but in a fairy land. Any one doubting the veracity of my statement can, when they have nothing else to do and can't sleep, call at 47, Baker Street, and convince themselves that it is no misstatement.—I am, Sir,

ONE LATELY BURNT OUT AT THE PORTLAND BAZAAR.
 August 7, 1863.

MEASURING THE ANGLE OF PHOTOGRAPHS.

DEAR SIR,—On seeing the letter of inquiry by "Tanno Glycerine" in the News the other day, I thought of a simple method of determining the angle included by any photographic lens. I had before me a view taken from the window of a house, with a No. 1 triple lens, on a 7½ plate. I cut two narrow strips of cardboard, say ¼ in. broad, and 6 in. long, jointed them at one end by a pin. I then placed the jointed

end as close as possible to my eye, and, placing myself at the window from which the view was taken, I extended the slips of cardboard till the angle thus formed included exactly the same objects as the photographs. On measuring the angle thus obtained with a protractor, I found it to be 50°. If this method is sufficiently correct, no photographer need have any difficulty in ascertaining the angle included by his lenses.—I am, dear sir, yours respectfully,

J. W. REFFITT.

[The method described may be used. We shall, however, shortly describe a neater application of the same principle.—Ed.]

Talk in the Studio.

ROYAL CORNWALL POLYTECHNIC SOCIETY.—We call the attention of our readers to the announcement in our advertising columns of the annual exhibition of this spirited and meritorious society. It will be seen that, amongst the awards to merit, a silver medal is set down for the best specimen of photography. Mr. J. C. Stephen, one of the oldest practitioners of our art, informs us that there is a small Art Union connected with the society, in which some of the prizes are usually photographs, and that he will be happy to render any assistance to photographers who may wish to dispose of their productions in connection with this enterprise.

A DISGRACE TO PHOTOGRAPHY.—A letter recently appeared in the *Daily Telegraph*, detailing an outrage which we regret should be possible even to the humblest and least scrupulous of those who practise the art. It says:—"A ruffian, who styles himself a photographic artist, established for the present in the Strand, was waited upon a few days since by a respectable young woman from the country, for the purpose of having her likeness taken; and on completion being, as she affirms, so totally deficient in resemblance, and wretchedly executed, she declined to receive it, and required another portrait. This was refused by the gentleman in attendance, who rudely informed her that he should not suffer her to quit the apartment until his demand was satisfied, if he kept her therein all night, using, at the same time, the most coarse and abusive language. He then locked the door, tucked up the sleeves of his shirt, and threatened to place her behind the fire-grate. In alarm and indignation she rushed to the window, to attract the attention of the police, and while doing so, this paragon of artists insultingly reminded her that she was showing her legs. After an imprisonment of upwards of an hour, an officer was summoned and admitted, who at once released the captive, and advised her to bring an action against Mr. B. for illegal detention, giving her at the same time his number to assist in such a measure, should its adoption be determined on. The affair will be strictly investigated; meanwhile, this statement may serve as a caution to female strangers in London, who may have the ill-fortune to be caricatured and imprisoned in like manner by a miserable pretender to a noble art, of which he has proved himself so utterly unworthy a disciple." In a subsequent number of the same journal, we find the following paragraph:—"Mr. J. Barry, photographer, of the Strand—in reference to a letter which appeared in our impression of Friday last, forwards us a communication in which he disclaims any share in the transaction referred to. Mr. Barry, we may add, was not alluded to in the communication in question."

To Correspondents.

W. G. H.—Some photographers object to the use of bromo-iodized collodion for collodion-albumen plates; but it is simply on the ground that if the collodion contain bromide the plates in their first stage should be kept from the light to avoid any chance of fog, whilst, if a simply iodized collodion have been used, there is less danger of the light acting upon the plate with its first coating. We use bromo-iodized collodion always; we believe Mr. Madd does so. You may use the mixture to which you refer, we should think without danger, but it will probably require thinning with ether and alcohol. 2. The condition of the bath for the first exciting is not very important; it may be neutral, or slightly acid with either nitric acid or acetic acid. Theoretically, the latter would be best; but in practice we have not found it important. 3. You can at any time neutralize nitric acid in a bath, either by the addition of freshly precipitated oxide of silver, in which case nitrate of silver would be formed, or with carbonate of soda, when nitrate of soda would be formed, which is inert in the bath. You can in either case add acetic acid afterward.

W. W.—The article on dry collodion to which you refer is, as you state, in many respects very valuable, but in some parts a little obscure. The use of the silver bath in which the plates were excited is undoubtedly meant, but we presume the plate is to be moistened with it by pouring on, not redipping. Mr. England's plan of keeping a bath of 10 grains of nitrate of silver to the ounce, with 5 minims of acetic acid, for redipping the plate, is a good one.

R. O.—You cannot treat a half-plate lens in any way to make it take card pictures in a room 7 feet long. You must have a lens of very much shorter focus, which would not define properly for a standing figure; or you must have a much larger room.

J. B. N.—We have never met with an ensé in which the gold in the toning bath of acetate of soda and chloride of gold was thrown down; but if from some unexplained cause it occur, the toning bath will be useless and will not tone. The print you enclose is certainly imperfectly toned. Try a fresh sample of acetate of soda; or read the article in our last on toning and follow the recipe there given. The formula you state is a good one, and need not be used in a more concentrated state. At present we do not see at what point the cause of your failure in toning arises. You use too much front light. Let us know of your further results.

UNA BOMBA.—It is quite possible to take very excellent portraits with a view lens; but it will be slower when stopped down subjeitely, than a portrait lens.

COANUS CHOUGH.—Send us one or two of the prints and we can better advise you. We shall then see possibly whether the faults be in the lens or the use of it.

GEORGE NEAL.—Send us a stamped and addressed envelope, and we will send you the address of a photographer from whom you can obtain lessons.

A. M. sends us two examples of paper excited on a bath of 20 grains nitrate of silver, and 60 nitrate of soda, both failures. We have not tried the process ourselves, nor can we say in what our correspondent has failed, but it is certain that he should have obtained better results than those forwarded to us. The bath should be a little acid rather than in any degree alkaline.

CHARLES FRANCIS.—A landscape background without gloss may be painted in flatting or distemper. If the former be desired, use oil colour mixed chiefly with turpentine, the smallest possible amount of oil being used. If you prefer the distemper, mix lamp-black and whiting with size to the proper consistency.

F. D. N.—We use the hypo bath made with one ounce of hypo in five ounces of water. It is impossible to say how much should be used for 100 prints without knowing the size of the prints, and even then it would be difficult to state absolutely. If the prints be card pictures you may use 2 or 3 ounces of hypo in 10 or 15 ounces of water, keeping them moving about all the time, and then after using that quantity throw the hypo solution aside.

J. BRAGESS.—Your pictures are all very good, both card and the larger one. We prefer the photography to the colouring. The latter is not bad, but the colours are a little too crude and glaring. The same skill in application with a little more dilution of the colours to secure delicacy of tint will doubtless give good results. We shall be glad to know your method. The print on resinized paper is very effective.

G. A. B.—The negative produced with iron development, without intensifying, certainly does not lack intensity. The prints generally are good, that with the single lens appears to have a somewhat abrupt perspective; and the lens is, we presume, of very short focus, too short for general purposes.

ANGLE-OMNIA.—A single view lens will generally give a circle of light of a diameter equal to the focal length of the lens; but the whole of that will not be defined without a very small stop, and even then straight lines will be curved in the margins. 2. In using the protractor to measure the angle, as we recently suggested, remember that the rule refers to the focus for parallel rays. If a very near subject be taken the focus is lengthened, and the measurement must be for the actual focus. That is, if the objects are so near that the focus of the lens is lengthened an inch, you must increase the length of the perpendicular set up on the base line of the picture by that amount; otherwise your calculations will be in error. We shall enter more fully into the subject shortly. 3. Yes; very complicated.

A CASE OF NEED.—Received from "W. D." 2s.; and from "Anon." 1s. 6d.

W. G.—We have often regretted that opticians leave so much doubt as to the real focus of the lenses in their catalogues. We cannot undertake in all cases to explain them with certainty. We believe the term "combined focus" has reference to the measurement from the back glass. We are not familiar with the lenses referred to as designated by various letters. You can easily ascertain the equivalent focus of the lens you have purchased by placing an engraving against the wall, and after obtaining an image exactly the same size on the ground glass, unscrew the lens and measure the distance between the ground glass and the engraving; one-fourth of that distance is the equivalent focus.

G. F. T.—With an ordinary quarter-plate lens you will have great difficulty in getting standing figures perfectly defined, without much stopping down, which will make the exposure long. For sitting figures it will answer better.

JOHN VANHEEM.—We learn on inquiry that the delay has arisen from the illness of the manufacturer. The reason you have not had an answer to your letters appears to have been the result of oversight.

Photographs Registered during the Past Week.

- MR. JAMES BERKE, 44, Lower Ormond Quay, Dublin,
 Photograph entitled "Pets of the Parisian Ballet."
 Photograph entitled "Celebrated Artists."
 Photograph of Archbishop Whately.
- MESSRS. T. AND J. HOLLAND, Esplanade House, Harrogate,
 Photograph of H. R. H. Prince of Wales.
- MR. JOHN STUART, 120, Buchanan Street, Glasgow,
 Photograph of Nana Sahib.
- MR. GEORGE WAREING ORMEAD, Mill Street, Chelmsford, Devon.
 Two Photographs of Water Wheel and Miners at Vitifer Tin Mine.
- MR. WILLIAM FOX, Sandbach,
 Two Photographs entitled "Contentment."
- MR. A. BROTHERS, 14, St. Ann's Square, Manchester,
 Two Photographs of Rev. J. Pyne, Rochdale.

THE PHOTOGRAPHIC NEWS.

Vol. VII. No. 259.—August 21, 1863.

CONTENTS.

	PAGE		PAGE
Next Year's Photographic Exhibition	397	Double Printing. By the Rev. S. Miller	405
Photographs in Printing Ink	397	False Claims in Regard to Medals of the International Exhibition	405
Formic Acid in the Developer	398	How to Clean Glass Plates	406
Major Russell's Recent Modifications in the Tannin Process ..	398	Photographic Notes and Queries—Want of Intensity in Dry	
Scientific Gossip	401	Weather	407
The Value of a Wide Angle in a Picture	401	Talk in the Studio	407
M. Cahagnet's Printing Process. By Ernest Lacan	402	To Correspondents	408
Photolithography	403	Photographs Registered during the past Week	408
By what Means can the Art of Photography become a Science? ..	403		

NEXT YEAR'S PHOTOGRAPHIC EXHIBITION.

WE are glad to announce that notwithstanding a heavy loss to the Photographic Society incurred by the last exhibition, arising from a variety of causes beyond control, it has been resolved by the council that the idea of foregoing an exhibition next year, at one time entertained, will not be carried out. A sub-committee is already appointed to take time by the forelock, and secure, if possible, a suitable room for a desirable season.

We regard photographic exhibitions of most vital importance, not only as landmarks of efforts and opportunities of illustrating to the public the advancement of the art; but also as incentives to efforts and aids to improvement, in a degree not easily over-estimated; and we have learnt this determination on the part of the council, therefore, with great interest. Having regard also to the reasons given, we cannot say that we are surprised that the council have been driven to another determination, just announced: that of charging non-members of the society with a certain portion of the expenses of the exhibition, in the form of a small rent for space. This cannot be regarded as unreasonable. The holding of an exhibition in the heart of the best part of the metropolis, advertising it, engaging attendants, &c., involves a heavy outlay of money, which is paid out of the funds contributed by members of the society. When they exhibit, they are merely availing themselves of the opportunity afforded by the expenditure of their own money. If it were not expended so, they could have its value in the shape of presentation prints, &c. But if non-members have the same privileges of exhibition, sale of duplicates, &c., which belong to members, they have such privileges at the cost of members of the society, and a manifest injustice is perpetrated.

As to the question of precedent or practice, it is not worth while discussing it, as examples might be cited both of charging non-members, excluding non-members, and admitting them to all privileges of exhibition scot-free. In the present instance it is manifestly just, as well as expedient, since it is alleged that some of those who have exhibited largely and profited largely by their exhibition, have declined when solicited to become members of the society. Photography, as a profession, has been very profitable to many; as an accomplishment it has been a great delight, and its own exceeding great reward to many more; and it is a somewhat humiliating thought that the expenditure of a guinea a year should be grudged by those who can afford it, for the maintenance of a representative society to uphold the general interests and dignity of the art on all necessary occasions, whether by exhibitions or any other means. To say that the society is managed with less energy than it might be, is simply to complain of supineness in individuals, as the whole would be more energetic if every part were more active; and any who hold aloof because they are not quite satisfied with the society as it stands, simply fail to avail themselves of the opportunity, by their own personal influence, of effecting some improvement. We recommend

at least all who have any idea of profiting by the opportunity of exhibiting next year, to become members of the society as soon as it opens its winter session. We append a short article from the journal of the society, announcing the decisions to which we have referred:—

“At a numerously attended meeting of the Council of the Photographic Society, held at King's College, on the 4th inst., the subject of the Annual Exhibition of the Society was brought under consideration. The Exhibition of the present year has shared the fate of nearly all others which have taken place since the great international gathering at South Kensington, and has left a considerable deficiency to be made good from the resources of the Society. It has been unanimously determined, however, by the Council that we shall not abandon our annual display of the progress of our art, and that every exertion shall be made to obtain a suitable gallery for the purpose, where the public may view the photographs during what is generally known as the London season. A committee of three gentlemen practically acquainted with the subject, have been appointed as a committee to carry out the wishes of the Council and to whom every detail of the working of it will be entrusted. The Council, at the same time, resolved that it should truly be an exhibition of the “works of the members of the Society;” and although other photographers, not members, should be invited to contribute, they must not consider themselves aggrieved by being charged a certain rent for space, which will only be given after the requirements of the members have been supplied. This change from former years has been thought needful, from the large number of pictures sent by contributors who have no connection with the Society, otherwise than for the display of their photographs, and who largely profit by the sale from their exhibition. The Secretary drew attention, in illustration, to the fact that, having written to a well-known photographer (who has yearly exhibited and profited much by the Exhibition), to ask if he would be desirous of joining the Society as a member, he was informed by him that he saw no use in *any* photographic society, but would wish his own pictures to be all favourably placed on the line of view. There has been some delay in finishing the dies for the medal which was awarded at the close of the present season, in consequence of the great demand for such works on the occasion of the marriage of the Prince of Wales. We may rely on having them speedily completed; and thus early intimate that a series of prize medals will again be distributed to the best artists in the several classes of photographic art. The award of the gentlemen who so kindly gave the subject of the distribution their careful study, met with general approbation; and two gentlemen to act as judges, who need not be members of the Society, will be requested to give their aid in a similar manner on the forthcoming occasion.”

PHOTOGRAPHS IN PRINTING INK.

WE have received from Mr. Ponney a specimen of his new carbon process printed on mica. The prints so produced possess great delicacy, and from the perfect transparency of the medium it presents greater facilities for obtaining perfect purity of colour than paper. Except for very small miniatures, however, we prefer the effect of paper. The

mica has, moreover, if mounted on card, a tendency to separate in portions, giving a blistered effect.

From the experiments we have made we have arrived at the conclusion that it is much better to over-expose than to under-expose; that a soft, delicate negative is better than a very vigorous one; and that it is most desirable to print in direct sunlight. If the print be over-exposed, it is not worthless, as it becomes a very fine transparency; but if it be under-exposed it is devoid of half-tone and very unsatisfactory. If the negative be very dense, especially if it be printed in the shade, it not only requires very long exposure, but has a tendency to excess of contrast, yielding a vigorous, but hard print; whilst a thin, but good, negative yields very soft, and at the same time vigorous results. If the printing be effected in a dull light the length of exposure appears to be increased in a ratio greater than we find with silver prints. We have with soft negatives obtained good prints with an exposure of from half an hour to forty minutes in direct sunlight; and, in one instance, from over-exposure, a fine transparency in three-quarters. On the other hand, a few days ago we exposed some in Leamington, at Mr. H. P. Robinson's establishment, with very fine, but vigorous negatives, for about four hours in dull diffused light, and obtained a hard picture after all.

As regards the final result, there is, as we have before said, still something to hope for. Whilst, as regards half-tone, nothing is wanting, the gradation being as perfect as in a silver print; there is a want of the rich colour and bloom of a good silver print, and there is a want of the velvet-like blacks and pure whites of a good engraving. The colour, we think, may be improved by the addition of certain suitable pigments in the first preparation. But there will, we fear, be a slight want of brilliancy and purity in transparencies mounted on card, deriving the character of their lights from the white card on which they are mounted. We have found that mounting them on card having a very slight tint of pink or buff, gives great warmth, without any appearance of positive colour. Something is to be done by experiments in this direction, but we adhere to the conviction that it is to a method of transferring the prints to plate paper we must look for the finest results. If this can be effectively done, we see no reason why we should not have pictures with the brilliancy, purity, and permanency of engravings, with the detail, gradation and truth of photographs. The original preparation of the paper will require modifying to render it suitable for this purpose, requiring probably a greater body of ink which must contain a larger proportion of fatty matter. One attempt which we made to transfer, with the paper prepared for retaining the impression, was a signal failure, no trace of the ink passing to the transfer paper, notwithstanding that the attempt was made whilst the ink was quite wet from the bath of turpentine in which final washing from the superfluous ink had been effected.

Mr. Sutton states that in the course of his experiments with the process, he has just made an improvement in the original preparation of the paper, for which we shall look with interest.

FORMIC ACID IN THE DEVELOPER.

Mr. MALONE, writing in a contemporary recently, says, "Considerable discussion has arisen upon the subject, and much evident misconception prevails." He then adds, to illustrate, "A contemporary writer, for instance, hastens to publish a reclamation of Mr. Lyte's, which shows that a further exposition of the nature and claims of the new process is needed." He then proceeds to make the needed exposition by giving similar details of Mr. H. Claudet's operations to those we had published some weeks previous. A re-perusal of our remarks on Mr. Lyte's claim will convince Mr. Malone that the misconception to which he refers rests entirely with himself. Mr. Lyte made no reclamation from Mr. Claudet, nor did we publish any. Mr. Claudet

never made any claims as to originating the use of formic acid. He very liberally described a process of using it which he had worked out successfully, and we had the pleasure of publishing his communication upwards of twelve months ago, and describing the very fine specimen of its results with which he favoured us at the time. We believe Mr. Claudet's claims to the especial combination upon which his success depends have never been doubted. Mr. Maxwell Lyte's reclamation referred to an inadvertency of our own, and, therefore we hastened to publish it. We had stated that the use of formic acid in photography originated, we believed, with the Rev. J. Lawson Sisson, in 1853. Mr. Lyte informed us that he had published it some months previously in the same year. His reclamation had reference solely to the original use of this acid in the developer. We do not remember any specific reference to the accelerating character of formic acid until 1861, when MM. Ferrier and Sonlier made some such claim, but without publishing any particulars.

The first published formula with direct reference to its qualities as an accelerating agent, was given in the PHOTOGRAPHIC NEWS, two years ago, by Col. Stuart Wortley, writing to us from Italy, where he had been using the process with great success. The specimen we then received was one of the most charming we have ever seen; and the grand instantaneous views taken in Italy, which obtained a medal at the last Exhibition of the Society, fully confirm the value of the process. A correspondent of the *Photographic Notes*, who has recently been working the panoramic lens at Lisbon, writes that he is just about to try it for instantaneous sea views, "using," as he says, "Lieut.-Col. Stuart Wortley's developer, with iron and formic acid." We have no doubt, that he will succeed. Col. Stuart Wortley's instantaneous views were produced with a lens upon which, at one time, the stigma of slowness was cast—the achromatic triple. It is to be remarked also, that he uses a very acid bath, a much as two or three drops of nitric acid being added to each ounce of silver solution; and also a highly bromized and highly alcoholic collodion. With these he secures all the conditions of rapidity, delicacy, and brilliancy in a degree rarely equalled, and never surpassed.

MAJOR RUSSELL'S RECENT MODIFICATIONS IN THE TANNIN PROCESS.*

Few men have ever devoted more persistent and consecutive attention to the working out and perfecting of an idea in connection with photography than Major Russell has done in the tannin process. For three years he has steadily experimented with the process he invented, in its every phase and modification. Always courteous and accessible, he has been willing to exchange ideas with all interested in the matter, receiving and weighing suggestions, and communicating information with equal readiness and good will. Such a course could not fail to secure progress, and we are quite prepared for the announcement in the preface to his new edition that "since the publication of the first edition the process described in it has been greatly improved."

The chief improvements in result are greatly increased sensitiveness, better and softer pictures, and the facility of working on the plain glass without a substratum of gelatine. The chief improvements in method consist in the free or exclusive use of bromides, in the use of alkaline development, and in production or selection of the most suitable qualities of collodion. A great portion of the new edition is entirely re-written so as to re-state carefully all the desirable conditions in their most suitable form, and much new matter is given. If the photographer fail in obtaining good results with the tannin process, it cannot be from lack of information, for we do not remember that any single process in photography has

* "The Tannin Process." By C. Russell. Second edition. London: J. W. Davies.

received such perfectly and conscientiously detailed explanation as we find in the little volume before us.

PRELIMINARY COATINGS.—Notwithstanding that the gelatine coating may be dispensed with, the author considers it in most cases an advantage, and that, as it involves less care in cleaning plates, the amount of extra trouble is balanced. The gelatine solution, as now recommended, should contain both an iodide and a bromide like collodion.

The method of preparing it is given as follows:—

Soak twenty grains in eight ounces of distilled water and four drops of glacial acetic acid. When thoroughly swelled and transparent, dissolve by warming. Should the water be heated before the gelatine has had time to swell, the latter will adhere to the bottom of the vessel containing it, in a stiff glutinous state, and will dissolve with great difficulty. Dissolve three grains of iodide of cadmium, three grains of bromide of cadmium, and a small piece of iodine in a few drops of water, and mix with the solution; then filter two or three times through white filtering paper in a warm place. The acetic acid coagulates the white impurity, which then collects into filaments, and is removed by filtering, leaving the liquid very bright. This solution will keep well without alcohol, and it is better not to add it, as it tends to produce ridges in the film of gelatine, especially when present in large proportion.

A coating of india-rubber dissolved in benzole may be used instead of the gelatine. One grain of india-rubber sliced very thin is to be dissolved in an ounce of benzole, and then filtered. As Major Russell states that some difficulty is found at times in getting the india-rubber to dissolve, we may remark that we have found solution much more easily effected if just sufficient chloroform to cover the india-rubber be poured over it first. This readily dissolves the india-rubber, and the proper degree of dilution may be secured by adding benzole afterwards. The coating of india-rubber should be dried by the fire.

COLLODION.—One of the most important chapters is that on suitable collodion, a subject which has manifestly occupied much of the authors' attention. He says:—

Almost any collodion will produce good results with tannin if properly managed, no matter how new and horny or how old and rotten. Even should it be too old or too new to work well in the wet process, it will still succeed. Some difference will, however, be found in the character of the resulting pictures, though not so great as in the wet process, and there will be a great difference in the sensitiveness. A new collodion is the most sensitive, and in the writer's hands gives the proper red tone and vigour of negative perfectly. An old and powdery sample on the other hand, even if rendered colourless by cadmium, besides being very insensitive, gives a pale grey image which will not develop with quite so much vigour and richness of tone, and the film, when varnished, is soft and liable to injury, whereas that produced by a new and horny collodion is, in hardness and durability, only inferior to albumen.

Simply iodized collodion may be used, but the presence of bromide greatly increases sensitiveness. Any collodion which is sensitive, and gives good results in the wet process, if it does not contain iodide of potassium, may be rendered suitable for use with tannin in the following manner:—If the collodion is not iodized, to one ounce of iodizing solution* add three drachms of alcohol, s.g. .805, and fifteen grains of bromide of cadmium. If the collodion is already iodized, dissolve ten grains of bromide of cadmium in six drachms of plain collodion and two drachms of alcohol s.g. .805, and mix three parts of this bromized collodion with eight parts of iodized collodion. If so large an addition of bromide is found to retard the setting of the collodion too much, as may possibly be the case with some kinds, a smaller proportion must be used.

Positive collodion will require less bromide, as it usually contains some already; but the exact proportion of iodide and bromide is not of much importance. The addition of bromide of cadmium to collodion iodized with iodide of potassium produces, by double decomposition iodide of cadmium and bromide of potassium: the former impairs the fluidity of the collodion, and the latter, being nearly insoluble in strong alcohol, is

almost all precipitated. If, therefore, the presence of iodide of potassium in iodized collodion is shown by turbidity on the addition of bromide, it will be better to dissolve equal parts of bromide of ammonium and bromide of cadmium in the smallest possible quantity of alcohol s.g. .816, and to add this solution cautiously until turbidity is produced. The collodion will be found to be very little altered in fluidity, and, when cleared by subsidence, to have retained enough bromide to improve it greatly for this purpose; but from its admitting of the use of but little bromide, such collodion cannot be expected to give a great amount of sensitiveness.

Should any doubt be entertained as to the good effect of so large a proportion of bromide as that rendered above, it may be easily removed by the following experiment:—Prepare nine different portions of the same collodion in such a manner that the first contains only iodide, the second one part bromide to eight iodide, and so on, increasing the proportion of bromide by one-eighth in each until the last contains equal parts of iodide and bromide. If a tannin plate is prepared with each of these portions it will be found on trial that the first addition of bromide has greatly increased sensitiveness, and that considerable increase is gained by farther additions up to three parts bromide to eight of iodide; after this, the increase of sensitiveness with each successive addition becomes less. Between one part of bromide to two of iodide, and equal parts of each, the difference is not very great, but sensitiveness continues to increase with every addition of bromide, and, as recent experiments seem to show, the greatest sensitiveness is obtained by the use of bromide alone; this, however, requires different treatment, and when iodide is used at all it is not usually advantageous much to exceed the proportion of three parts bromide to five parts iodide.

Successive additions of bromide, up to equal parts of iodide and bromide, do not seem to diminish intensity, but they increase the tendency to blurring with the same exposure; this may, however, be only the effect of greater sensitiveness. A very large proportion of bromide is likely to impair too much the setting of some collodions, and during the long stay in the bath rendered necessary, crystals containing iodide are apt to form on the film, even when the nitrate solution is not over-iodized.

Bromide of silver forms a transparent combination with the collodion, to a greater extent than iodide of silver; a greater weight of iodide and bromide together should therefore be used in a given quantity of collodion, than of iodide, if it alone were employed, otherwise the film would be less opaque. The different proportions of iodine and bromine in various iodides and bromides, and peculiarities in the quality of the pyroxyline, might slightly affect the proportion of bromide which can be used consistently with working well.

Collodion which gives a dense and horny film works well with tannin, but a somewhat porous film is more sensitive. A porous texture may be obtained by preparing the pyroxyline in acids at a high temperature, but it seems better to produce the effect by using a full proportion of water at a moderate temperature; still greater sensitiveness may in this way be obtained, the pyroxyline is more soluble, and the collodion becomes clear by subsidence more quickly.

Bromo-iodized collodion will produce good results, but simply bromized collodion is strongly recommended as being in most cases preferable; the latter is about twice as sensitive as the former; and seems, so far as it has been tried, to have no tendency while in the exciting bath to form the needle-shaped crystals which are so common an annoyance when the collodion contains iodide. Above all, the bromized collodion will produce a better negative when the subject presents great contrast, such as sky and dark objects, as it will bear over-action of light better, and shows no tendency to produce blurring along the edges of the strongly lighted parts of the subject.

Bromized collodion seems to be particularly suitable for use with tannin. In a great number of trials with different kinds of collodion, and various modes of treatment, the iodide and bromide in no one instance approached the bromide in sensitiveness, even when the latter was used in a much less sensitive collodion, or in quality of negative with a landscape subject when both were exposed long enough for the darkest parts.

Two precautions are necessary when bromide alone is used: First, not to use a very slow-setting collodion—probably almost any sample intended for the wet process will answer; second, to excite in a strong bath, and keep the bath in long enough.

* If this contain iodide of potassium, which may be known by its becoming turbid on the addition of bromide of cadmium, it will be better to prepare a fresh iodizing solution by the formula to be given.

It is much easier to make pyroxyline suitable for bromide than for iodide, as in the former case the point of solution must not be so nearly approached as would be desirable in the latter. Besides this, the sensitiveness of bromide does not seem to be so much affected as that of iodide by the mechanical state of the collodion.

Many experiments have been made to ascertain the best kind of pyroxyline for use with bromide. Three parts of sulphuric to one part of nitric acid will give a kind which works well, but is rather deficient in sensitiveness. When equal parts of sulphuric and nitric acid are used, the collodion flows well and is very sensitive, but has too little setting power. Two parts sulphuric acid, and one nitric acid, seem to produce the best results on the whole. The formula already given does not make a collodion which will set quickly enough; but, if modified in the following manner, answers at least as well as any which has been tried:—

Boil a quarter of a pound of the best American cotton for two hours in a gallon of water and two ounces of caustic potash, as recommended by Mr. Hardwich; then wash by alternately holding under a stream of water and pressing strongly between the hands. In this way the potash is removed much more quickly than by soaking. If worked well the whole time, about twenty minutes' washing will be sufficient. Dry thoroughly, and immerse in the acids at a temperature of 125°, and keep in for twenty minutes; wash in the same manner as after the potash. After about fifteen minutes press out the water well, and pour on the pyroxyline as much weak solution of bicarbonate of soda as it will hold; then wash well again in the same manner as before. In all points not specified Mr. Glover's formula is to be followed.* The gain in weight should be about fifty per cent.

This pyroxyline is very soluble, and makes a bright collodion which is fit for use in a short time; sets, if anything, too quickly, and keeps very clean in developing, but is not very fluid. If the collodion is not found to flow freely enough, it may be mixed with some made by Mr. Glover's formula. It is much easier to regulate the quality of the collodion in this way, by varying the proportions, than to make a sample of pyroxyline which will give exactly the qualities required; but, if preferred, the temperature of the acids and time of immersion may be intermediate. For instance, the temperature 135° to 140°, immersion about fifteen minutes.

BROMIZED COLLODION.

Pyroxyline	5 grains.
Bromide of cadmium	8 do.
Alcohol '805	4 drachms.
Ether	4 do.

Put the whole in a tall, narrow bottle, shake up until the solution of the pyroxyline and bromide is complete; then allow to settle, clear, and decant. If the alcohol is weaker, or if the pyroxyline is of a kind likely to give too little setting power, a larger proportion of ether should be used.

No fear need be entertained that the bromide will burst out like iodide, if even in larger proportion than that given above; but if the collodion is of an unsuitable kind, and will not set well, irregular markings of unequal thickness in the direction of the dip may be formed, and, if so, will be plainly visible by transmitted light, although the surface, when dry, will probably be quite bright.

The addition of a few drops of a strong alcoholic solution of bromine† to an ounce of the collodion, seems to be an improve-

* Mr. Glover's formula, given on a former page of the work, is as follows:—Prepare the cotton by boiling in a five-per-cent. solution of pearlsh; wash thoroughly from the alkali, and dry perfectly.

Sulphuric acid, 1 '845	5 ounces.
Nitric acid, 1 '370	2½ "
Water	1 drachm.

When the temperature sinks to 145°, immerse two and a half drachms prepared cotton, in tufts of not more than thirty grains each, taking care that each tuft is well saturated. Cover up for ten minutes. Then lift out with two glass spatulas, squeezing out as much of the acids as possible, and throw into a large quantity of water, separating the cotton so as to dilute the acid as quickly as possible. Change the water every five minutes, six times, well squeezing between each change, during which time it must have the sole attention, as I find the more rapidly it is washed the more soluble is the product. To the last change of water add ten grains bicarbonate soda, which neutralizes the last traces of acid without affecting the nature of the pyroxyline. Rinse and dry rapidly.

† To make this solution, pour three fluid ounces of alcohol, s.g. '805, into a thin beaker, and place on the far side of a bottle of strong solution of ammonia from which the stopper has been removed. To avoid the ill effects of the noxious fumes of the bromine, do not remove the stopper from the bottle which contains it until it is held beyond the ammonia, and keep it

ment, but bromine can only be used with a quick-setting collodion, as it tends still more than bromide to retard the setting. The yellow colour given by the bromine will probably soon disappear, but the collodion will retain an acid reaction.

The bromized collodion should be excited in a sixty-grain bath, and should be kept in for about fifteen minutes. If the formula given above is followed, the film will be very creamy. The collodion may be made much thinner by the addition of ether and alcohol, and it can then be excited in a weaker bath, and more quickly.

When both are prepared with a weak solution of tannin, and developed in the ordinary way with nitrate of silver and acid, the bromized collodion is far more sensitive, and gives better results than bromo-iodized collodion; but the former develops much more slowly than the latter, and produces intensity with difficulty. With the alkaline developer, which will be described, the bromized collodion develops very readily, and easily produces ample intensity when tannin solution of sufficient strength has been used.

THE NITRATE BATH.—The nitrate bath may be used neutral or slightly acid with nitric acid. If for use with bromized collodion only, it is to be saturated with bromide of silver only. To prevent the accumulation of nitric acid it is recommended to filter the solution from time to time through filtering paper holding a little carbonate of silver. The author says;

Another good plan is to keep the bath solution in the dark room with carbonate of silver enough to form a deposit in the bottle about a quarter of an inch deep. If the bottle contains a much larger quantity of the solution than is required for use, it may be poured off clear without filtering; a little nitric acid may then be added. For this purpose dilute one part s.g. 1.360 with two parts water; one drop of this will be enough for from ten to thirty ounces of the bath. The exact quantity of acid necessary will depend on a variety of circumstances. This plan is better than the addition of iodine to simply bromized collodion, and appears to answer exceedingly well. If a little free bromine can be used in the collodion, much the same effect will be produced, with perhaps less loss of sensitiveness, and no acid need be added to the bath. The bath being neutralized every time after use, precipitates nearly all the little organic matter it may have acquired, and a very small trace of acid will keep the pictures clear, as the bath is always used in a freshly acidified state.

The amount of sensitiveness obtainable in this or any other process depends greatly on the smallness of the quantity of acid required to prevent fogging. When the bath is kept permanently in an acid state, the accumulation of organic matter will render more and more acid necessary. A bath treated as just described will give nearly the highest attainable degree of sensitiveness, and is not likely, if used with bromized collodion, to get out of order unless by absorbing in time a large quantity of alcohol. It will be as well to add, after pouring out for use, a small quantity of plain nitrate solution of the same strength as the bath, about as much as it wasted the last time used. A piece of thin filtering paper pressed over the mouth of the bottle, instead of the stopper, will keep out dust, and at the same time permit the escape of the ether, and of much of the alcohol, and of the carbonic acid liberated by the nitric acid from the carbonate of silver.

A strong bath is better than a weak one, as it enables us to use a thick and highly-iodized or bromized collodion, and so to produce an opaque film; in all cases it saves time by exciting more quickly.

It is recommended that plates for all dry processes should be left a longer time in the nitrate bath than is usual for the wet process, and especially where the collodion contains much bromide. The use of iodized gelatine for a preliminary coating also renders a longer immersion necessary.

Washing.—The mode of washing recommended is by the use of two successive immersions in distilled water, in a dipping bath, and then in two or three changes of common water in which the plates should lay not less than half an hour.

there as long as open. Pour into the alcohol about one ounce by weight of bromine cautiously, a little at a time, stirring with a glass rod, as much heat will be evolved. Cover with a glass plate, and when quite cold, pour into a bottle which stops well.

We must defer further comments upon, and extracts from, this valuable work until our next.

Scientific Gossip.

IMPROVEMENTS IN THE SPECTROSCOPE—BISULPHIDE OF CARBON PRISMS—ANALYSIS OF THE FIXED LINE D.

SINCE we last gave our readers any account of the spectroscopic and spectrum discoveries, several important improvements have been made in this branch of inquiry. One advance has been made in the angle and position of the prisms. In the ordinary instrument, in which prisms of 45° or 60° are employed, the light falls upon the first surface at a considerable angle, and, therefore, half of it at least is reflected from the polished glass to the sides of the box and is lost; the other half passing into the prism and being refracted both at its entrance and exit. For convenience of measurement, and for certain theoretical considerations, it is always recommended to place the prism in the angle of minimum deviation, or, in other words, in such a position that the incident and emergent ray shall make the same angle with the prism. Dr. Walcott Gibbs has recently had constructed an instrument in which an entirely new principle is involved. In this spectroscope the prism of flint glass has a refracting angle of 37° only. The beam of light, after passing through the slit, is rendered parallel in the usual manner by a collimating lens having the slit in its principal focus. It then falls on the first surface of the prism; but this, instead of being at an angle, is so placed that the ray of light meets it perpendicularly. In this case, therefore, there is no appreciable loss by reflection, but the whole of the light passes into the body of the glass without any refraction whatever. The bundle of rays then meets with the second surface of the prism, and, of course, makes with this an angle of 37° . The refraction in this case is very great, and it takes place at an angle so near the limiting angle that the refracted rays emerge nearly parallel to the second surface of the prism. The amount of dispersion produced in this way is very great, whilst the loss of light occasioned by reflection at the first surface in prisms of 60° placed in the position of minimum deviation is avoided. It will be evident, from a little consideration, that the refracted rays in an instrument of this construction diverge as if from a single radiant point situated on the second surface of the prism, and, therefore, the vertical axis of the instrument round which the telescopes rotate must be in a line with this second surface. The spectrum thus produced possesses remarkable intensity, and the dark lines are seen in countless numbers, and with great distinctness. The instrument in this form is sufficient for all chemical purposes, but it is so constructed as to permit the use of a second prism by which the length of the spectrum is, of course, greatly increased. Though the telescopes are only six inches in length, with a magnifying power of about six, the spectrum compares very advantageously with that of a large apparatus with telescopes of 18 inches focal length, and $1\frac{1}{2}$ inch aperture, and a prism of 60° .

An instrument possessing the most wonderful powers of resolving spectral lines has just been constructed for Professor Cooke. From an account given in a private letter, we believe that this instrument is the largest and most powerful ever yet applied to the spectrum. It has nine prisms, filled with bisulphide of carbon, having $2\frac{1}{4}$ inches aperture, with telescopes of corresponding size. By means of a conical wheel, against which the backs of the prisms rest, they are enabled to be adjusted with great facility to the angle of least deviation. Two pins on the back of each prism are so adjusted that when pushed against the wheel the back of the prism is tangent to the circle. By means of this simple contrivance, the adjustment can be made from one end of the spectrum to the other in a very short time. The prisms

are constructed on a plan suggested by Professor Rood. The frames are made of cast iron; after the faces have been worked nearly true, plane parallel plates of glass are cemented on the sides with a mixture of glue and treacle. After a few days, the bisulphide of carbon is poured in through an opening, which is then closed with a screw. So far, the construction of the prisms is old and attended with a most serious defect, which has, perhaps, prevented the general introduction of these prisms; for if the light from the slit be allowed to fall on the face of a prism thus prepared, and reflected from it along the axis of the observing telescope, it will be found that the image of the slit is *distorted* to a greater or less degree; further examination shows that the glass plate has been slightly bent by the hardening of the glue, the curvature in many cases being considerable. If two or more such prisms are used for the production of a spectrum, a certain amount of confusion is always seen amongst the fixed lines; plates of glass of even the fourth of an inch in thickness are constantly affected in this manner, and unless the evil be removed the prisms are of no great value. This difficulty is corrected by Professor Rood, in the following manner: The prisms are finished, in the way above described, with glass of good quality, then a few drops of olive oil are placed on one of the faces, and a plate of truly plane glass laid on it; the oil spreads out, and is held in position by capillary attraction; the four corners are then secured by four drops of melted wax and resin. Optical contact is thus secured, and the slight curvature corrected; each face is in turn thus dealt with. Large prisms of bisulphide of carbon thus corrected, while remarkably cheap, approach a degree of optical perfection not attainable by the best flint glass prisms yet produced, for even if the flint prism is of equal size with that of bisulphide of carbon, and optically unexceptionable, the fact still remains that the dispersive power of the latter is greater. The nine prisms of Professor Cooke's instrument are prepared in this manner, and as the light is here bent through almost 360° , we have reached about the limit of power, unless we can reflect back the rays over the same path.

This instrument has established the following points.

1. That the lines of the solar spectrum are as innumerable as the stars of heaven. It shows distinctly at least ten times as many lines as are given by Kirchhoff in his chart, and an infinitude of nebulous bands just on the point of being resolved. We have seen a drawing of the fixed line D of Fraunhofer as seen by it. Our readers will remember that it requires a very good instrument to see this line double at all. Kirchhoff, in his chart, only gives three lines, the two broad ones and a faint central one. Professor Rood found that three line lines were enclosed within this double line. By this new instrument of Professor Cooke nine additional lines are seen enclosed within D, one being a nebulous line which may be resolved into other lines upon an increase of optical power.
2. It proves that the coincidences between the bright lines of the metallic spectra and the dark lines of the solar spectrum remain perfect even with this greatly increased power. By it the two members of the sodium line can be spread so far apart that the $\frac{1}{100}$ th of the intermediate space can be readily distinguished, and yet the coincidence with the two dark Fraunhofer lines is still absolute.
3. It shows that many of the bands of the metallic spectra are broad coloured spaces, crossed themselves by bright lines. This is the case with the orange band of the strontium spectrum and with the whole of the calcium and barium spectra to a remarkable extent.

THE VALUE OF A WIDE ANGLE IN A PICTURE.

In a recent article in *Silliman's Journal*, Mr. Coleman Sellers has some good remarks on the value of including wide angle in a photograph. We cannot altogether endorse his remarks as to the want of progress in the chemistry of

photography, but cordially agree with him as to the optical improvements. He says:—

“Photography, with the discovery of the use of collodion, seemed to leap into its present high position at one bound, at least so far as the chemistry of the art is concerned. The negatives of to-day look like the negatives of the first experimenters, and the chemical process of their production is essentially the same. But with the optics of photography the case is different; here there has been a steady improvement. The wants of the portraitists have been met by the construction of new objectives suited to the style of pictures to be produced. In these instruments depth of field, with free admission of a large volume of light, was what was most sought for. Theory could not dictate what shape or combination of lenses would best produce this result; and patient experiments were resorted to. The requirements of landscape photography are quite different from those of portraiture. A portrait tube may be used to take views if it be provided with a stop or small opening to limit the amount of rays passing through it, and thus to deepen the field, or increase the “reach” of the instrument, as it is technically called. This involves loss of light, and consequently diminishes the quickness of its working. We hear continually of rapid or instantaneous photography, and are often led to believe that the rapidity is to be ascribed to some wonderful sensibility of the chemicals used; but this is only partially true, and to the optician is due the most of the merit of instantaneous pictures. A portrait tube with its full opening will, in a skylight room, produce a picture in perhaps ten or fifteen seconds. This same instrument, with the same opening and same chemicals, exposed to an extended view in bright sunlight, could not be opened and shut quick enough; the immense volume of light reflected from so large an area of space being concentrated on the same-sized plate, as in the first case, would be too violent in its action, and, from the nature of the instrument, near and distant objects could not be brought into focus at the same time.

“The human eye, when the head is at rest, takes in an angle of view of at least 70° or 80° , the whole of which is not seen clearly at once, but can be examined in detail by the almost unconscious rolling motion of the eye in its socket—the actual included angle of clear vision at any one instant being only 1° or 2° . Hence a picture of a landscape, for instance, to fill the eye and seem a true representation of nature, should include an angle of at least 60° . Ordinary instruments, such as have heretofore been used, do not include an angle of more than one-half this amount; and hence has originated the complaint that photographic views represent mere patches of scenery, and not pictures. I remember once standing on a bridge, camera in hand, and looking up the romantic Wissahicon. The picture presented to my eye was very beautiful—the centre a waterfall framed in on both sides by wild and rugged rocks, and spanned above by the arch of a railroad bridge crossing at the tops of the cliffs. The foreground was made up of a stony bed, where danced and foamed the rapid current. I planted the camera, and hoped soon to peel off from this charming view a cuticle (as Dr. Holmes says) which, like plates of mica, could be split and re-split for the collections of my friends. But on the ground glass I found nought but the tumbling water. No rocks, no bridge, no stony river-bed: the poor camera, in its empty head, was incapable of taking in the whole of the charming picture. One of the dreams of the photographer has been of an instrument which should embrace a large angle, and thus satisfy the wants of the eye; but with the majority of the attempts in this direction came other evils, the greatest of which was distortion of the marginal lines. The aplanatic lens of Grubb is said to comprise an angle of 70° ; but in a view before me of Trinity College, Dublin, taken with this lens, there is a curvature of the straight lines of the roof of more than one-eighth of an inch in its length. Mr. Sutton’s panoramic lens, a sphere

of glass filled with water, includes a very large angle over 100° , on the base-line; but the pictures are produced on curved plates, which require curved holders, baths, and printing-frames, and, in the case of architectural pictures, the right lines are distorted, unless the picture be bent to the curvature of the plate upon which it was taken, and thus viewed near the centre of the curvature.”

He then proceeds to describe in enthusiastic terms, the new globe lens, with which he appears to be much pleased. We cannot help being somewhat struck with the fact, that whilst Mr. Sellers and others in America writing on the subject, seem angry at what they conceive to be the want of appreciation this lens has received in England, they systematically overlook in their comparisons the triple lens, which, we have before observed, is equally free from distortion and superior to the globe both in rapidity, perfection of definition, and amount of angle included. If the triple lens did not exist, the globe lens would, from its wide angle and freedom from distortion, be a great boon to photographers; as the matter really stands, it was forestalled in this country by a better instrument.

M. CAHAGNET'S PRINTING PROCESS.

BY ERNEST LACAN.

At the moment when M. Wothly exhibited to us the excellent proofs he obtained by his new printing process, we learned that an experimentalist, whose name was not unknown to us, M. Cahagnet, was also in possession of an economical printing process. Wishing to satisfy ourselves of its merits, we set out one fine evening for M. Cahagnet’s rural retreat, in company with one of the most eminent Paris photographers, desirous merely of being satisfied as to the truth of what he had heard respecting the new method.

It was nearly sunset when we arrived at the door of the inventor’s dwelling. M. Cahagnet, who did not expect our visit, hastened to place before us the numerous results of his experiments, at the same time giving every explanation we required, concealing neither the difficulties to be overcome nor the pleasures of success, nor the hope of still more perfect success. We have had the good fortune to find ourselves very frequently, for several years past, in contact with many inquirers, investigators and inventors, and we came to the conclusion that our obliging host may be classed among the most sincere.

The proofs he exhibited to us are taken upon that sort of cardboard used for *cartes de visite*, and resemble very much in appearance collodion positives transferred by Moitessier’s process. They are remarkable for their delicacy and the great purity of the whites. The ground may be obtained white or tinted. The tones resemble those of an engraving, but, in our opinion, they have the defect of being rather heavy. We saw pictures of small dimensions only, without being so perfect as those obtained by M. Wothly, which surpass the best proofs obtained by the old methods—these results are in every respect satisfactory. With regard to the method, the following is from a letter on the subject, addressed to us by the author:—

“The enamelled cardboard proposed to replace the salted or albumenized papers for the production of photographic pictures, presents the following advantages over those papers.

1st. Its size is $26\frac{1}{2}$ by 20 inches, while that of the papers referred to is 23 by 18 inches.

2nd. The chloridizing and albumenizing being suppressed, these two substances are economized.

3rd. The sensitizing bath, costing only two and sixpence the pint, increases the cost of the sheet (sensitized on both sides, and giving, consequently, a double picture) only to twopence, which, added to the cost of the card, threepence, makes the cost only fivepence per sheet, while albumenized paper, being smaller and sensitized on one side only, costs tenpence.

4th. The time of sensitizing is only 25 seconds, while

that of nitrating is five minutes, consequently a man may sensitize in one hour as many as would require, under ordinary circumstances, a whole day.

5th. This cardboard may be kept sensitized as long as a month, or even longer, without losing any of its good qualities, an advantage offered by no other kinds of paper hitherto. From this property it can be sent to any distance, or kept in the operator's portfolio until it is convenient to use it.

6th. The time of exposure to light is the same as with other papers.

7th. Fixing is accomplished by means of a simple washing in running water for a few minutes.

8th. Toning is dispensed with.

9th. This cardboard endures immersion in alcohol varnishes or fatty substances. Colouring, and, consequently, painting, may be applied to it without causing any change in it. This is an additional protection against atmospheric influences.

10th. Being exposed to no destructive fixing agent it yields faithful positive proofs.

11th. It can be formed into albums and books, the picture being visible upon both sides.

12th. I have possessed for more than a year a large number of pictures obtained upon this cardboard. I have recognised no change in the pictures, nor in the pure white grounds you have seen.

You know very well, sir, that in photography any innovation concerning papers proposed for the production of pictures raises, above all things, the question of time, while those concerning sensitizing or developing baths for negatives can be appreciated instantly. It is therefore very difficult for the students of this question to speak enthusiastically before the judgment which time alone can pronounce. This method, now presented to notice, is supported by the experience of a year, and, consequently, has some claims to consideration.

You know, also, that the papers hitherto employed have made us seek a better preparation and more satisfactory results, consequently I believe we may satisfy the wants of the moment by the employment of the porcelain card (which never exhibits any defect) and in presenting it to the photographic world."—*Le Moniteur de la Photographie*.

PHOTOLITHOGRAPHY :

THE VARIED ACTION OF LIGHT UPON BITUMEN AND BICROMATES.—A NEW TRANSFER PROCESS.

BY JOSEPH LEWIS.

It is a fact I think not generally (if at all) known, that the principal sensitive substances at present in use to fix the offset of the photographic original on stone, viz., the bichromate of potash, with an organic medium, or the bitumens, effectually reverse or exchange their relative qualities under the effects of light. The bitumen is changed from a greasy, water-repelling substance, to that of a neutral insoluble material, having lost its property to repel water when applied to its surface. In this way I spread a solution of bitumen in lavender oil, or turpentine, upon a smooth stone, and when dry expose it for some hours under a transparent positive in good light. If we then wet the stone over with a little gum water and apply the printing ink roller, those portions unaltered by light will become charged with ink, while the altered bitumen, having lost its repellant power, remains wet, and the printing ink cannot adhere to a wet surface. Hence the early experimentalists failed to produce substantial effects by bitumen alone; they began at the wrong end—by washing away the *vital* printing surface and labouring hopelessly to charge with ink the faint brown impression left on the stone, whereas the solvent employed had washed away every particle of greasy principle. However, by this experiment we get a result which I have not reduced to a perfect success, for want of time to follow it up.

Now, in respect of the bichromate of potash and the organic substances when acted on by light, the effect is reversed; these, in their primitive state, are neutral in respect of moisture, but when decomposed by the light exhibit the qualities of a greasy substance, repelling water, and can be inked up as a lithographic stone. The bichromate, in combination with an organic medium, becomes, by the action of light, what has been termed insoluble; this, I think, is not correct nomenclature—there are many substances insoluble that will not attract printing ink, if moisture be present there is something more than insolubility imparted by the actinic influence; it appears to be converted into a *resinous* substance.

Reasoning upon results, I concluded to try the effect of a combination of these two opposite sensitive substances. I took one ounce of black asphaltum, a quarter of an ounce of suet, as much bicarbonate of soda as a shilling would take up, melted them in a pot, then added as much finely powdered bichromate as of soda, and a little fine black to colour. This mixture readily dissolves in turpentine, and in that state is brushed over a smooth card or paper surface; when dry, it should be pressed on a smooth wetted stone, to get a perfect surface. It is then ready for exposure under a transparent positive, or ordinary print, for some hours in good light. It is then to be submitted to the *capot* of turpentine for a few seconds (or the clean stone may be coated with a film of turpentine); the exposed surface is placed rapidly next the stone and submitted to the pressure as in the ordinary transferring, when, if the exposure has been properly timed, a perfectly sharp transfer will be found on the stone in *bona fide* transfer ink.

BY WHAT MEANS CAN THE ART OF PHOTOGRAPHY BECOME A SCIENCE?*

By the same means by which all arts become sciences; that is, by making systematic experiments, by recording results, and by combining these results so as to lead to infallible conclusions.

The chemical materials used in photography are numerous and are increasing daily; the experiments, therefore, must increase in the same proportion, otherwise results will remain without reasons. Every photographer can render important aid in this branch; he can make any amount of experiments; and, with a little system, he can make experiments that will be of great service to the department; and the photographic journals are always ready to record the results of such labours. From the accumulation of facts thus made, minds thoroughly educated in natural science will be enabled to make legitimate syntheses, that conduct to the causes and thus simplify the art.

Throughout the whole extent of the United States, as well as in several other countries, men are employed in different localities to record the direction in which the wind blows during the twenty-four hours of the day; the thermometric changes during the day; the variations in the height of the mercurial column during the same period; the diurnal, hebdomadal, mensural, annual, secular, and periodical variations of the magnetic needle; the fall of rain, snow, hail, &c.; the appearance of clouds, haloes, meteors, &c. These men are mere tools, experimenters, recorders of phenomena or facts; they draw no conclusions from what they see, and yet they are very *useful men*, like purveyors to the quartermaster, they accumulate heterogeneous materials which, systematically arranged, indicate definite causes and definite results.

In the course of time meteorology will become a fixed science, in which manifest laws will eventually prognosticate the change and direction of wind, the direction and spread of epidemics, the fall of rain, hail, or snow, and the change of temperature.

If photographers in like manner would organize themselves into a regular system of experimentation, there would be hopes of arriving at very beneficial results, and of drawing conclusions that can be derived from no other source.

But photographers say: What experiments shall we make?

* From *Humphrey's Journal*.

We will tell you some of the experiments that would be of great service.

An accurate table is needed of the solubility of the different salts used in photography in the different menstrua in which they may occur; for instance, we want to know exactly how much iodide of potassium can be dissolved in a given quantity of alcohol of a given strength; also of bromide of potassium in the same menstruum. The degree of solubility in alcohol of all the prominent photographic salts would thus form one table.

Another table would comprehend the solubility of the same materials in ether; a *third* that of the same substances in water; a *fourth* the solubility of the compound salts, such as *iodo-nitrate* of silver, &c., in a solution of nitrate of silver. A systematic view of the changes that occur in the different baths from the introduction of the different salts either on the collodion plate or the salted paper, would be of great practical value.

Photographer *A* may study the substance *nitro-glucose* in all its bearings, its composition and decomposition, its action on collodion, &c. This would be a very interesting addition to our photographic knowledge.

Photographer *B* will gratify the public by devoting himself to the study of the substance formed by the gelatinization of cotton in nitric acid, that is of gelatinous pyroxyline.

Photographer *C* can throw a quantity of collodion into distilled water and study thoroughly the precipitate both *gelatinous* and *fibrinous*. This will form the subject of two very interesting investigations.

Photographer *D* can experiment upon the solubility of pyroxyline in the different proportions of alcohol and ether.

Photographer *E* can take for his study the decompositions or reductions effected by the protosalts of iron on the collodion film after exposure. (Make no speculations; observe facts and note them well without any bias). This is a splendid subject for minute study.

Photographer *F* & Co. can make a comparative investigation of the action of light on chloride of silver, iodide of silver, asphaltum, bicromate of potassa and gelatine, &c., the persalts of iron, &c.—each one is a study of itself—let the experiments be directed to the ascertainment of the fact whether the action be *physical* or *chemical* or *both*.

Photographer *G* may take for his lesson or task the study of the reductions produced by gallic and pyrogallic acid on an exposed film.

Photographer *H* can by experiment try to find out by what principle of chemistry acids moderate the action of the reducing agents in the developing process.

Photographer *I* receives for his lesson the study of the reduction produced by the vapour of mercury on an exposed sensitized silver plate. Do not speculate—make experiments so as to derive some clue from the concatenation of their results.

Photographer *J* can investigate the (apparent) anomalousness in *this*, that a sensitized wet collodion plate when washed and exposed yields no picture by development, whereas the dry collodion plates are *thoroughly washed* and yield pictures.

Photographer *K* can study out the reason why an *acid gold* toning solution tones much more rapidly than an *alkaline gold* solution. He must show by experiment how it comes that the deposition of the gold in one case is so much more rapid than in the other. Compare this work with that of *H*.

Photographer *L* will gain a *prize* if he can distinctly diagnose the malady of the bath or the collodion which produces *PIN-HOLES*. Dust, iodo-nitrate of silver, acetate of silver, undissolved iodide of potassium, and bromide of potassium, &c., bear the onus of dreadful charges against them—find out, *by experiment and careful exploration* of the diseased ground, what is the true cause of the morbid manifestation—an infallible remedy will be the making of you.

Photographer *M* will study the anomalousness of results in reference to the introduction of formic acid into the developer. Claudet, Noyt, and others, assert that formic acid so introduced shortens the time of exposure; whereas Monckhoven and others do not obtain satisfactory results. Let the public know your experiments as soon as convenient, and what these experiments have determined.

Photographer *N* would interest the public by a careful set of experiments on the developing solution containing *tartaric acid* instead of acetic. This bath is said to produce sufficient intensity without redevelopment. The developer may be tried as follows:—

Water	4 ounces.
Sulphate of iron	1½ drachm.
Tartaric acid	18 grains.

A longer time of exposure is required with this developer than with the ordinary acetic acid iron developer. Try with less tartaric acid and report results, for the rest of your fraternity are on the pinnacle of expectation.

Photographer *O* has to investigate the peculiar conditions of an old and a new collodion, that will permit him to say what the causes are why the new collodion is more sensitive but produces less intensity than the old collodion, and *vice versa*.

Photographer *P* can experiment with the protosalts of iron, so as to determine in what way the protonitrate is superior to the protosulphate of iron as a quick developer; also in what way nitric acid or nitrate of silver is beneficial in the development of an ambrotype.

Photographer *Q*, if he is anything of a natural philosopher, will investigate the different degrees of intensity in actinism between the morning and the evening light, and between the spring and the autumn light.

Photographer *R* might commence a course of experiments on the action of polarized light on the sensitive films; these experiments may, perhaps, be of service to *Q*; I would advise these two philosophic photographers to enter into partnership and experiment together.

Photographer *S* may experiment in a totally new field. Let him combine nitrate of silver with collodion, albumen, gelatine, varnish, &c., and see if some new plan cannot be devised of obtaining sensitized films by inverting the proceedings, first saturating with silver and then sensitizing with the chlorides, iodides, and bromides. Something of this sort has already been attempted in France, and the results were published in *this journal*; exhaust the subject by experiment, and let us know what is to be expected of the change.

Photographer *T* may experiment on vision at long and short distances, and ascertain from facts why the eye is cognizant of a near and distant object co-simultaneously. To make these experiments you must be an anatomist and a physiologist, as well as a photographer and optician.

Photographer *U*, whether utopian or not, I would advise to ally himself with Niepce de St. Victor in the prosecution of the study of taking photographs of objects in natural colours. Certain colours can be photographed, but *not fixed*—the subject is worthy of investigation—it does not appear to be *utopian*—leave Becquerel's experiment and try fresh ground.

Photographer *V* would interest photographers if he could devise quick, easy, and practical methods of printing directly in the camera on prepared paper by development. This is a great desideratum, namely, to be enabled to take photographs on paper of a proper rich tone in the camera, as quickly as ambrotypes. This is not *utopian*, either. Experiment.

Photographer *W* may prosecute a course of experiments in celestial photography. His experiments are to be limited to the investigation of results to be obtained by repeated magnifying copies of the moon's disc taken on daguerreotypes. Is it not possible in this way to get a glimpse of the man of the moon? See to what extent copying and magnifying can be effected without the total annihilation of the object.

Photographer *X* may institute a course of experiments with the salts of chrome in gelatine, &c., to be used instead of collodion; see what can be accomplished in this way, and report at your leisure.

Photographer *Y* may conduct a systematic course of experiments on exposed plates or papers, by connecting them with either pole of a galvanic battery, either with or without metallic solutions in contact; see whether the actinic action is either increased, decreased, or unchanged by any of these arrangements, and study thoroughly the nature of the action, be it what it will.

Photographer *Z*, being the wisest man in the class, knowing all about the nutation of the earth's axis, the precession of the equinox, the secular disturbance of one planet upon another, being versed in the reason of a balloon's ascension, or a cloud's descension, of the rising of sap or the fall of gold, that is, being a man that knows how to put two and three together, or that two and three make five—*Z*, I say, will have for his task the collation of the reports of all his brethren preceding, and the deduction of causes.

DOUBLE PRINTING.

BY THE REV. S. MILLER.

[In the United States the process of double printing has recently been resuscitated, or rediscovered, with modifications. "Master Charley," an ingenious young amateur, son of the Rev. S. Miller, a contributor to *Humphrey's Journal*, has initiated the process. We now quote his father:—]

One day he came to my study with a face all radiant with smiles, and laid on my table a number of vignette portraits as the results of his new experiment. One was the portrait of a lady surrounded with a wreath of flowers. Another had a landscape as a background. Another a battle field for its foreground, himself looking out on the scene from the background as if he had been the general commanding. Another placed a lady friend in company with the newly-married Princess of Wales and her bridesmaids. Another made a gentleman figure on a valentine in the midst of all sorts of hard and soft hearts. Another gentleman was introduced to a wedding party, and yet another was made a spectator at a French bee dance.

The family were called in to see the new pictures. It afforded one of those pleasures we often enjoy as a family circle of amateurs. All were delighted, and Charley was duly complimented by his sisters. No one could guess how the thing could be done, and they made him sit down and tell how he did it. It was all plain and simple enough when explained. They call them the Carlotypes, to which the artist makes no objection, being conscious that the process by which he produced them was the result of his own unaided experiments.

His double printing process is entirely different from that given by Dornbach, whose articles he had never seen; and the pictures themselves are of a different style. The process is very simple, and yet it possesses a feature that would puzzle some older heads to understand how it is done, without being explained. He can print, for instance, a dozen of these pictures, each one with a different background in precisely the same time required to print an equal number of ordinary pictures; thus affording any variety of chemical backgrounds without additional time and labour in the manipulation beyond that required in the single process.

If the trouble connected with the production of these backgrounds is the reason why the subject has not received more attention from practical operators, that reason no longer exists as far as vignette portraits are concerned, to which the present experiment has been so far confined. There is room left accordingly for still further improvements, in order to produce like results with standing figures with the same facility.

May not the time come when double and even triple printing will be as common and as profitably applied in the photographic art as it is in the art of printing, and with like pleasing and popular results?

The carlotypes, as our young amateurs persist in calling them, are produced by a double printing process, by which vignette or bust pictures, with any variety of backgrounds, are printed without requiring any additional time to that which is necessary to produce ordinary pictures. A dozen copies from the same negative, each with a different background, can be printed in precisely the same time that an equal number of ordinary copies are produced. I will describe the manipulation for the benefit of the lovers of variety.

1. Make a tasteful selection of appropriate objects for your chemical backgrounds. The sources from which these can be selected are unlimited. Every object in nature and art can be used for the purpose, and be represented in connection with portraiture. The backgrounds most easily obtained are those copied from prints and other portable works of art, from which alone a fine selection can be made.

2. Having made your selection, take a well defined negative of each. In doing so, bring that portion of the view which is to be occupied by the portrait, on the centre of the glass. These negative backgrounds are to be considered as part of your stock, being of permanent use if well taken care of. They should be well varnished and be kept in a separate box.

3. Cut out as many ovals from yellow paper as there are negatives, the size of a sixteenth or ninth part, or any other size or form to suit the design and size of your negative. The yellow paper used for letter envelopes will answer the purpose. Mount the ovals on the back of your negatives on the centre of your glass or place which the portrait is to occupy. They serve the double purpose to make room for the portrait and to pro-

tect it in the process of printing. The reason why they are pasted on the back of the negative and not on the collodion side is, for the double reason, to blend their outlines when desirable, and to enable you to remove them when so desired, without injury to the negative.

4. Cut out an equal number of ovals from white tissue paper a little larger than the former, and mount them on the yellow ovals, allowing them to extend over about an eighth of an inch all round. This serves to complete the blending of the outlines referred to; but is to be omitted when the outlines are to be sharply defined. Your negative or chemical backgrounds are now ready for use.

5. The next thing is the printing process. We will suppose you desire to print a dozen copies from a single negative, each to have a different background, and to produce them in the same time required for an equal number of ordinary vignette pictures. Very well. Have your paper ready and your portrait negative at hand. Place a prepared sheet of paper under the negative, and put it in a vignette printing frame. One on which the glass is fastened by means of spring cloth pins will do. Then place another sheet under a negative background, and put it in a common printing frame. Expose them simultaneously to the action of sunlight. When both are sufficiently printed, carry the frames on a table and open them. Take out the negative background and put another in its place. Then transpose the prints; that is, place the printed portrait in the common printing frame and the printed background in the vignette frame, adjusting them properly on the negatives, so that the portraits will be protected by the ovals. Expose them again to the action of light, when sufficiently printed, take out the copies, and repeat the operation; using a different negative background at each exposure.

You will note that whilst the portraits were printing, the backgrounds were printing likewise; so that by the time the former were printed, the latter were printed as well. No loss of time was therefore occasioned in producing the double impressions. The process is as simple as it is curious and pleasing in its results, and affords room for a pleasant variety of experiments for the amateur, to say nothing of the practical purposes to which it may be applied. The principle can be carried out still further, and with a triple process, pictures can be produced with three distinct impressions in the same time. As a contribution to photographic curiosities, I may at some future time describe the manipulation, and report results.

If this style of pictures could be made to find favour with the public, it would pay an enterprising publisher to get up a variety of beautiful designs, of a general and specific character, with the proper sized oval or square openings, expressly engraved for the purpose in the best style of the art, as patterns for chemical backgrounds. By this means exquisitely beautiful results would be produced, which would hardly fail to meet with favour by the public; thus introducing a new feature in practical photography, by bringing into its service the art of engraving as it has already done that of painting.

FALSE CLAIMS IN REGARD TO MEDALS OF THE INTERNATIONAL EXHIBITION.

WE have just received the report of a committee of gentlemen appointed by a meeting of medal holders, for the purpose of securing some protection to medallists against various fraudulent claims which had been put forth, for trade purposes, in reference to the awards of the jurors in the International Exhibition. It appears that in some instances the honours of the medallists have been claimed in advertisements by persons having no right to them whatever; in others medals awarded for one thing have been claimed for another; and various similar frauds have been committed. The existing law failing to provide a remedy, a short bill was prepared, which received the royal assent within eight days of its first reading in the House. It is entitled "The Exhibitions' Medals Act, 1863," and we extract its principal provisions for the benefit of those interested:—

Whereas it is expedient to prevent false representations with respect to grants of medals and certificates by the Commissioners for the Exhibition of 1851, and the Commissioners for the Exhibition of 1862: be it enacted by the Queen's most Excellent Majesty, by and with the advice and consent of the

Lords spiritual and temporal, and Commons, in this present Parliament assembled, and by the authority of the same, as follows:—

1. If any trader commits any of the offences following; that is to say,

- (1) Falsely represents that he has obtained a medal or certificate from the Exhibition Commissioners;
- (2) Falsely represents that any other trader has obtained a medal or certificate from the Exhibition Commissioners;
- (3) Falsely represents that any article sold or exposed for sale has been made by, or by any process invented by, a person who has obtained in respect of such article or process a medal or certificate from the Exhibition Commissioners;

He shall incur the following penalties; that is to say,

- (1) For the first offence he shall forfeit to Her Majesty a sum not exceeding five pounds.
- (2) For any subsequent offence he shall forfeit to her Majesty a sum not exceeding twenty pounds, or be imprisoned for a period not exceeding six months.

2. In proceedings under this Act it shall not be necessary to prove that any person has sustained damage by the false representations of the defendant. In proceedings under this Act the defendant shall be deemed, until he has proved the contrary, to have known the falsehood of any representation made by him that has been proved to be false. It shall not be necessary in any proceedings under this Act to set out any copy or facsimile of any medal or certificate.

4. Offences under this Act may be prosecuted summarily in England and Ireland before two justices. In Scotland, an offence against this Act may be prosecuted summarily at the instance of the procurator fiscal before any sheriff or before any two justices of the county, or before the magistrates or any police magistrate of the burgh in which the offence was committed.

5. No provision of this Act shall take away, diminish, or prejudicially affect any suit, process, proceeding, right, or remedy which any person may be entitled to at law, in equity, or otherwise; nor exempt or excuse any person from answering or making discovery upon examination as a witness, or upon interrogatories or otherwise, in any suit or other civil proceeding: provided always, that no evidence, statement, or discovery which any person shall be compelled to give or make shall be admissible in evidence against such person in support of any indictment for a misdemeanour at common law or otherwise, or of any proceeding under the provisions of this Act.

HOW TO CLEAN GLASS PLATES.*

An excellent starting point of success is to obtain a nice clean plate. A good operator knows that unless his glass is clean he has no security for obtaining a perfect picture. Many different methods have been given for effecting this apparently simple object, but the plan that seems to be perfection with one person, is declared to be useless by another.

New glass plates are always best; old plates many times used, or that have laid about with their dirty surfaces, or that have been varnished, are always to be regarded with suspicion. It is very doubtful if there is any saving in using a plate that has once been varnished. A truly economical photographer will have the courage to use the hammer to lots of his old glass rather than risk his materials, his time, and his temper on plates which may give only dirty pictures. The chemicals, especially the protosulphate of iron and cyanide of potassium, seems to act on the surface of the glass, so that after much using no amount of friction with acids or alkalis will prevent smears, marks, *ghosts*, comets, rockets, and other abominations. Now glass works well with very little cleaning. Patent plate is always the best; but for small sizes, up to 5 by 4, "flatted crown" will do, and "polished sheet" for larger sizes. It is a good plan, if there be a doubt whether the glass plates are flat enough, to put them into the printing frame, and apply quite as much pressure as will occur in printing, for few

things are more mortifying than to break a negative through using glass not flat.

To prevent cutting the fingers and tearing the cloths, the glasses should have their sharp edges and corners taken off, and to make the collodion adhere well at the edges, it is better if they are roughened a quarter of an inch all round. Sand paper, emery cloth, sandstone, or a little grooved instrument made of corundum and sold for the purpose at most photographic dealers, may be used.

New glasses may be simply washed under the tap with plenty of water, and dried on clean cloths. When quite dry, place the glass in a plate-cleaning holder, and pour on a few drops of pure alcohol; rub this well over the plate on both sides with a tuft of cotton wool. With a second tuft rub off the alcohol, and with a third one polish the plate. This will be found a safe and expeditious method of cleaning plates. The last tuft of cotton should be kept quite clean and dry, so as to leave the plate without lines or smears. If the reader has much trouble with dirty glasses, he is strongly recommended to try "Werge's Plate Cleaning Solution." The writer has used it for years, and is never troubled with dirty plates, and he feels he is doing his readers a service in calling their attention to this very useful preparation.

Every dark room should have a large dish provided, half filled with clean water, into which all spoiled plates should be immersed, so that the collodion film should not dry on the plate. By this plan much time will be saved in cleaning the glasses, and the plates will be kept in better order. The plates should not be left to lie in this water any longer than possible, and the water should be frequently changed. The fragments of collodion films should be added to the pan in which the silver residues are kept, as they all help to swell the amount.

The above simple means may not be satisfactory to some persons for cleaning their glasses, therefore the following plate-cleaning solutions are given, culled from a variety of sources:—

GLASS PLATE CLEANING SOLUTIONS.

No. 1. (Mr. Hardwich).

Make a cream of tripoli powder and spirits of wine, add a little ammonia; dip a tuft of cotton in the above, and rub the glasses for a few minutes, rinse them well in plain water, and dry on a clean cloth kept for the purpose, which cloth should be washed in pure water, or water containing a little common washing soda, but not with soap and water. Polish the plates with an old silk handkerchief, or clean chamois leather.

No. 2. (Mr. Hardwich).

Liquor potassæ	1 ounce.
Water	4 "

Wet the glasses well on both sides with the above, using a cylindrical roll of flannel to protect the fingers; allow them to stand while several are so treated. Wash them well, dry, and polish.

No. 3. (Mr. Lake Price).

Wash the plate with abundance of clean water running from a tap, wipe with old linen cloths kept scrupulously clean, and retained for the purpose. Polish with clean chamois leather, or old silk. If the plates are greasy, give them a preliminary wash in warm soda water; if they have been previously used, let them lie for six hours in a strong solution of caustic potash with thin slips of firewood between them to ensure the surface being acted on. When cleaning the plates, wear a pair of white cotton gloves to prevent the plate or the cloths being contaminated with the perspiration from the hands.

No. 4. (Mr. Sutton).

Rub the glass plate on both sides with a piece of flannel dipped in a thick mixture of whiting and water; wash off the whiting thoroughly, and put the plate in water acidified with nitric acid; wash again, and wipe dry with a clean

* By permission, from Hughes's "Principles and Practice of Photography." New Edition.

cloth kept for the purpose, and which must never be washed with soap. Before using, polish with a silk handkerchief.

No. 5. (Mr. Thomas).

Prepared tripoli	2 ounces.
Water	3½ "
Spirits of wine	4 "
Solution of caustic potash	½ "

With a tuft of cotton wool rub the plate well with the above mixture, wash the mixture off under the tap with another tuft, being careful to get the tripoli from the roughened edges. Let the plate remain in a deep dish of water till six plates are thus treated; take them out singly, wiping the edges with a tuft of cotton, and pass them through a dish of distilled water. Dry them with cloths washed without soap. Polish with chamois leather, and finish with a silk handkerchief.

No. 6. (Mr. Crookes).

Place two handfuls of common salt in a jug, and pour a pint of boiling water over it. Stir for some time, allow to get cold, and filter. Mix together equal parts of fine rotten stone and tripoli, and add about a teaspoonful to every six ounces of the above saturated solution of common salt. To use, shake the bottle well, and smear a little of the mixture over the plate with a rag. Now clean it well off by briskly rubbing with a clean cloth, and give the last polish in the usual manner. The crystallization of salt which takes place on the surface of the plate when the mixture is smeared over seems to loosen the dirt from the surface in a remarkable manner, and the after friction with the cloth brings away all impurities. Care must be taken that no salt is left on the edges of the plate, or it will decompose the bath.

In relation to the above, Mr. Crookes says, "That if the receipt be properly used, a failure from the employment of dirty glasses may be looked upon as a thing of the past."

No. 7. (Mr. W. Miers).

Water	1 ounce.
Hydrochloric acid	2 drachms.
Iodine	a few grains

Rub the plates over with a pad of cloth saturated with the above liquid, use a circular motion, and polish as well.

No. 8. (Mr. G. Wharton Simpson).

Nitric acid	1 drachm.
Alcohol	1 ounce.

Tripoli, sufficient to make a creamy paste.

Rub the plates well on both sides with the above paste, and set them aside to dry. In this condition they may be stored away; when required for use, rub the tripoli off with a fine clean cloth, and polish with a clean chamois leather.

To Clean Plates that have been Varnished.

Soak the plates in a saturated solution of common washing soda, and allow them to remain until the film comes off without any friction. If the solution is made hot, a few minutes will be sufficient; but cold, they usually require from 24 to 48 hours soaking. When the film leaves the glass freely, wash it well under the tap, and immerse it in weak nitric acid (water 5 ounces, nitric acid 1 ounce), for a short time. Wash well again, dry, and treat it as a new glass.

As the varnished side can never be much depended on, it is a good plan to mark the unvarnished side with a diamond before cleaning, and to use the marked side for putting the next collodion film upon.

Photographic Notes and Queries.

WANT OF INTENSITY IN DRY WEATHER.

DEAR SIR,—Many have complained recently of the want of intensity in negatives, and the dryness of the atmosphere has

been generally suggested as the cause. Allow me to state how I have overcome the difficulty (for it would not be convenient for every photographer to adopt Mr. Noel Fitch's plan, viz., to water the floor of the studio.) I simply coat the plate, and immerse it in bath, as quickly as possible. Hoping this hint will sufficiently explain how the dryness of the atmosphere affects the plate, and help others out of the difficulty.—I remain, yours truly,
J. BURGESS.

Talk in the Studio.

THE WATT PHOTOGRAPHS.—We understand that Mr. Smith, of the Patent Museum, is progressing satisfactorily with his researches into the history of the photographs taken during the last century, and hopes shortly to present indisputable evidence of the claims already made regarding them. A paragraph in a recent number of the *Bulletin* of the French Society strikingly illustrates the impolicy of the discussion on the subject, upon imperfect data, at a meeting of the Photographic Society of London, and which we personally deprecated at the time. The discussion is regarded in the French journal as upon the two pictures, resembling daguerreotypes, of Bolton's house before and after its alteration in 1791, and as having seriously decided that the pictures were not photographs at all. After rehearsing the question generally, the paragraph proceeds:—"A serious discussion at the Photographic Society of London, seems not to have left any doubt upon the origin of the images; they have not been produced by the direct action of light; they are simply pictures painted in the ordinary manner, perhaps designed in the camera obscura, and it is entirely to Niepce and Daguerre that the honour of discovering photography belongs." Englishmen have not been grudging hitherto in their tributes of honour to Niepce and Daguerre; it is simply a question of historic truth which now remains to be solved. But is it not somewhat odd that our neighbours forget that photography, as discovered by the savans their name has now ceased to be practised, and that the photography of the present day, on collodion and paper, was discovered by Englishmen?

PHOTOGRAPHY AT WIMBLEDON.—Mr. Ernest Edwards has just published some photographs of the recent rifle matches at Wimbledon, which volunteers generally will be glad to possess. We have before us two instantaneous pictures, panoramic in form, measuring about 10 in. by 6 in. One consists of Mr. E. Ross—himself, we believe, a photographer—shooting at one thousand yards, seated; and the other of Mr. Farquharson, shooting at the same distance, extended at full length on the ground, after his peculiar fashion. The pictures are exceedingly good, being delicate, soft, and well defined, except in the case of a few figures, which, notwithstanding the rapidity of the exposure, have moved a little.

PHOTOGRAPHY IN THE WITNESS BOX.—A singular use of a photograph was made in a recent trial in the Central Criminal Court. The charge upon which the prisoner, a lad of seventeen, was tried, occurred two years ago, and a photograph of him taken at that time was produced to prove that he had altered so much since that time that it was impossible to swear to his identity now. The jury, however, regarded it as a good likeness of him as he stood before them.

PHOTOGRAPHY IN THREE LESSONS.—This is the title of a terse little brochure just issued by Mr. Solomon. Its purpose is best explained by an extract from the introduction:—"This is entirely a book for beginners. It does not deal with the history of photography, nor its theoretical principles, nor its manufacturing chemistry. The beginner will purchase his apparatus and materials ready made; mix his preparations as we shall direct, and use them as we shall instruct him, his sole object at present being to take pictures. When he has accomplished this he will begin to inquire upon what principles this art is based, and make some practical experiments in its chemistry. But he will begin by learning the practice. A man learns to talk before he studies grammar." The three lessons consist of instructions for producing collodion positives, for producing collodion negatives, and for producing paperprints. The style is short, sharp, and decisive, and whilst there does not appear a superfluous word, the instructions are clear and explicit. We do not doubt that a person of average intelligence might take the book in hand and without other tuition produce pho-

tographs. The book finishes with a piece of excellent advice: the student having mastered the instructions before him is recommended to read the photographic periodicals and join a photographic society.

ARCHITECTURAL STEREOGRAPHS.—We have received from Messrs. J. and J. Dutton, of Bath, some exceedingly fine stereoscopic views, chiefly church interiors in Bristol and Bath. There is a very fine view of St. Augustine's Gate, Bristol, which is an unusually elaborate specimen of Norman architecture. There are also views of the interiors of Bath Abbey, Bristol Cathedral, and the church of St. Mary Redcliffe which are known to archaeologists as presenting fine examples of the early English, the Perpendicular, and Decorated styles of architecture.

TRANSFERS FROM ENAMEL PAPER.—We have just received from the Hon. Nassau Jocelyn, Secretary to the British Embassy at Berlin, some exceedingly beautiful specimens of the new process of transferring the film of albumen containing a photographic image, from the paper on to enamel glass, or other surface, for ornamental purposes, together with hints as to the method of manipulation. We have also received from Messrs. Harvey, Reynolds, and Fowler, some samples of M. Beyrich's paper, prepared for this work. We hope shortly to enter at greater length into the subject.

MR. PARKINSON'S LIME TONING.—We have recently received a letter from Mr. Parkinson on this subject, in which he expresses a conviction that if "Cha-meal-ion" had used as much ability and intelligence in applying the lime-toning formulæ as in writing his amusing letter, he could not have failed to secure success. He proceeds to say:—"Toning with me these last six months has been a pleasure instead of a trouble, and I am sure that the lime toning will eventually become universal, more especially as I have discovered, within this last week, that it can be used with that invaluable aid, *acetate of soda*. For the information of "Waxy," my paper is bought at Angouleme, gold at Paris, and lately I have changed my *fournisseur*, but with equally good results. The day before yesterday M. Disderi, called on me, and although very busy, I gave him a pose and a poser with the rapidity with which I work in my new atelier, and outside it is quicker than quick, as you will see by the enclosed equestrian carte. He was so pleased with the lens that he has taken Dallmeyer's address, and is going to write to him for one. I also took a *carte de visite* of Disderi, which I enclose." Mr. Parkinson proceeds to promise us some further remarks on his toning experiments shortly, and concludes with a challenge, as follows:—"Should 'Cha-meal-ion' happen to be a sporting man, I will take a series of pictures against his old hypo and gold, by my chloride of gold and lime processes, for £20 a side, and come to England to do it; any six *first photographers* to be the judges."

To Correspondents.

A MUFF.—A bath treated with carbonate of soda, as you describe, will, in some conditions, hold a trace of carbonate of silver in solution. When you add acetic acid to this you form acetate of silver, which, although conducive to density of image, and occasionally of advantage when a pyro-gallic acid developer is used, is not, in our experience, suitable for iron development, often giving insensitiveness and dirty plates. After neutralizing and sunning your bath, it is better to add nitric acid than acetic acid. If your bath reddens blue litmus paper and turn reddened litmus paper blue, there must be some impurity in your material or manipulation. A bath cannot be acid and alkaline at the same time. Possibly you tried it with the red litmus paper in the light, and you mistake the darkening by light for becoming blue. It frequently happens a dull light and short exposure reveal any fogging tendencies in a bath much more palpably than full exposure in bright light. The red deposit on the shadows whilst intensifying may often be prevented by an increased proportion of citric acid. The iodine solution you use for the purpose is much too strong; one grain to an ounce of water will make a solution amply strong enough. Try intensifying with iron 5 grains, and citric acid 5 grains, to which add a little silver without acid.

TYRO-TANNIN.—The difficulty you describe is a novel one; we have neither heard nor met with it before. We can perceive nothing in your material or manipulation to cause the small projections or bubbles you describe. We have before heard of the final spots which you state these bubbles or projections result in, but have not heard of the phenomenon being observable on the excited plate. From one hint you drop, namely, that an excited plate showing these projections when taken into daylight becomes covered with blue spots, seems to point to excess of bromide as the cause. Bromide of silver is readily reduced by light, and becomes of a bluish grey colour when so reduced. These spots then may possibly arise from excess of bromide in the collodion, or from the bath having become supersaturated with it; the latter most probably, and if so, sunning the bath would be the remedy. We will submit your letter how-

ever, to Major Russell, whose recent extensive experiments may enable him to throw some light upon the matter.

J. W. F.—The print enclosed has a very odd appearance, and from a mere superficial inspection it would be difficult to determine the cause. Examination by transmitted light, however, speedily suggests the source of the trouble. Your printer has floated the paper on the bath albumen side uppermost. By this means the bulk of the silver is in the body of the paper, and hence the image is there also, and is scarcely visible on the surface. By transmitted light this is very apparent, as the print is an excellent transparency. This is further proved by touching the back of the paper with the tongue, which at once detects the plentiful presence of free nitrate, whereas on the albumenized side it is scarcely perceptible.

J. D.—In working dry plates without preservative much seems to depend upon the collodion. Those samples which are old and slightly decomposed, or which are made from cotton with somewhat of the organic character, seem to answer best. But you can only get at the matter by experiment, as to which especial sample will answer. Plates so prepared are more sensitive than tannin, but less certain.

J. LEE informs us that he has used the lime toning formula we gave in No. 257 with great success. He asks, if Beaufort's concentrated chloride of lime may be used in a similar formula? We have not tried the preparation in question; but apprehend that, if used, must be in much smaller proportion than in using the common article from the oil-shops; the proper amount being ascertained by experiment.

J. C.—The fog on the deep shadows during intensifying with proto is not uncommon in hot weather. In our last volume the subject is very fully treated, and also in our *ALMANAC* for the present year. It proceeds from a variety of causes, and may be got rid of by different remedies. The simplest is to use a larger proportion of citric acid in the intensifying solution. The most effectual method is to have a solution containing 1 grain of iodine and 2 of iodide of potassium in an ounce of water; and after washing away the iron, pour the solution over the plate; then expose for a few seconds to the light, wash off, and proceed to intensify. With negatives in which, despite of precautions, the defect has arisen, it may sometimes be removed by the application of a weak solution of iodo-cyanide of potassium. This requires great care not to injure the half-tones. Another method is to pour a weak solution of bichloride of mercury over the plate, which, without much affecting the general character of the negative, will turn the red foggy deposit white, and thus render it of little consequence in printing.

A DRY PLATE.—The introduction of an organic salt into the silver bath not unfrequently produces the reduction you describe. A skilful and eminent photographer recently described to us just such a result with a bath made after Mr. Bartholomew's formula, but he added that its working qualities did not appear to be impaired.

AN AMATEUR.—You speak of developing with formic acid, as used by Mr. Claudet, and you add that your bath is nearly neutral. Now, if you have read the description of Mr. Claudet's method with any care you will have ascertained that he places great stress upon having the bath freely acidified with nitric acid. We can only suggest to you the importance in adopting any specific formula of working it out accurately in all its parts. Want of detail is most likely to occur from under-exposure, or the use of too much old potassium iodized collodion.

CHUCK.—It is probable that your bath has contained a large excess of acid, and requires still more carbonate of soda to neutralize it. You should add the soda until there is a slight permanent precipitate, and then expose the solution to sunlight. 2. We shall be glad to see the specimen of paper to which you refer. 3. Mr. Poncey is quite prepared, we believe, to supply his prepared paper to amateurs.

J. H. McALLAN.—Of course, your room would be better if the chimney were removed, but it is not imperative. Paint or paper the interior with a warm, light, neutral tint. Double sets of blinds, one dark blue, the other white, and on both sides. A good half-plate lens will answer for card pictures, but we fear that more than sixteen feet length will be required to enable you to use a lens of the usual focal length belonging to half-plate lenses.

SOLAR.—We are not aware of any house keeping mirrors and condensers for the solar camera. Probably Mr. Atkinson, of Liverpool, could supply them, and, possibly, London dealers would supply them to order. We remember seeing a condenser of French manufacture for sale at McMillan's, Fleet Street. The price would depend on the size; probably, for an eight-inch condenser, about 30s., if of French manufacture.

A CASE OF NEED.—We have to acknowledge from H., postage stamps amounting to 2s. 6d., and we are also glad to announce that an important contribution of apparatus has been made by "One of the Brothers of the Art," who desires to be anonymous.

THE MARSEILLES PRIZE.—We have no information as to how sensitive plates will reach Marseilles without being examined by the Custom House officers. We imagine, if duly and fully described outside, it is possible they might pass unopened. But we will make some inquiry.

W. L. N.—Press of engagements and the unfavourable weather have prevented us from giving the collodion a trial as yet. Several Correspondents in our next.

Photographs Registered During the Past Week.

- MR. ROBERT FLAMANK, jun., 25, Greengate Street, Stafford,
Five Photographs of Thomas Mulock, Esq.
- MR. JAMES RUSSELL, East Street, Chichester,
Photograph of a Wax Medallion Portrait of the late Rev. Dr. Chandler.
- MR. JOHN STEPHENS, 82, High Street, Whitechapel,
Photograph of Dr. Coffin.
- MR. JOSEPH ALFRED WATSON, Park Road, Saltley, Birmingham,
Photograph of Plate presented to Joseph Wright, Esq.
- MESSRS. MOIRA ANN HAIGH, 1, Lower Seymour Street, Portman Square, W.,
Three Photographs of Dr. Herne.
- MR. A. D. LEWIS, Leaburu Street, Alnwick,
Two Photographs of Mr. Alexander Murray.
Two Photographs of Mr. and Mrs. Alexander Murray and Miss Murray.

THE PHOTOGRAPHIC NEWS.

Vol. VII. No. 260.--August 28, 1863.

CONTENTS.

	PAGE		PAGE
Sulpho-Cyanide of Ammonium at a Low Price	409	Correspondence—Foreign Science—A Difficulty, &c.	417
Major Russell's Recent Modifications of the Tannin Process ...	412	Photographic Notes and Queries—Roughing the Edges of Glass	
Sensitive Plates and the Custom House	412	—Successful Lime Toning—Gold Toning Bath, &c.—Var-	
Photography in Australia. By Paul Ricochet	412	nish for India	419
Photolithography.—II. By Joseph Lewis.....	414	Miscellaneous	419
Photography as an Accomplishment. By Rev. S. Miller	414	Talk in the Studio	420
Albumenized Glass Process. By Charles Waldack	415	To Correspondents.....	420
The New Gold Toning Bath. By Rev. S. Miller	416	Photographs Registered during the past Week.....	420

SULPHO-CYANIDE OF AMMONIUM AT A LOW PRICE.

THE results of some experiments a few months ago, limited, it is true, in number, but carefully conducted and very conclusive, led us to the conviction that if this salt could be manufactured at a reasonable price it would take the place of hyposulphite of soda as a fixing agent, and at once free the photographer from many of the evils which attend its use supplying the place by one equally efficient, more stable, not readily liberating sulphuretted compounds, nor spoiling prints by the formation of an insoluble and unstable salt in case of under-fixation. A general impression to this effect seemed to prevail in most cases where the sulpho-cyanides were tried. The price was, however, an insuperable difficulty. It was impossible to employ, commercially, for fixing photographs, a salt which cost four shillings an ounce. That objection has, however, ceased to exist.

We have just received from M. Meynier, of Marscilles, the gentleman to whom the original suggestion of the new fixing salt is due, two large bottles containing a fine sample of sulpho-cyanide of ammonium. This salt, which is very perfect, and in fine, clean, colourless crystals, he is now manufacturing and selling at the price of three francs per kilogramme. This, in English money, is half a crown for two pounds and a fraction under a quarter, or about one shilling and three-halfpence per pound.

The question of price, even now, may cease to be a consideration; and M. Meynier states that if the consumption becomes general he has no doubt of being able to manufacture it at the price of hyposulphite of soda.

We have tried the sulpho-cyanide of M. Meynier for fixing, using the proportion we employed on a former occasion, one part in three of water, which is a much greater strength than that originally recommended by M. Meynier. The results varied very slightly from those we obtained before, but the differences might possibly be due to the character of the paper, &c. The solution seemed more energetic, reducing the prints both in colour and depth to a greater extent than we before found it. Let us not be misunderstood, however; the reduction was not greater even now than with hyposulphite of soda. The colour, a deep purple, obtained in the toning bath, simply became a purple brown, or rich warm sepia tint. In some cases the tint was peculiarly rosy purple in the shadows and pink in the half-tones. The whites were perfectly pure, exhibiting no trace of yellow.

M. Meynier informs us that he finds the use of a bath containing sulpho-cyanide of ammonium and chloride of gold very satisfactory for toning. It is composed as follows:

Sulpho-cyanide of ammonium	...	6 grammes.*
Chloride of gold	...	1 gramme.
Water	...	1 litre.

* A gramme is about 15½ grains, and a litre 35 ounces.

The print immersed in the bath acquires, first, a lilac tint, and passes through violet to black, if left in the bath a sufficient length of time. The solution will be found to have an acid reaction, and, if a fine black or violet tone be desired, it should be neutralized by the addition of a few drops of ammonia, or of a solution of carbonate of soda. It is then to be fixed in another bath of sulpho-cyanide of ammonium alone, M. Meynier using, we believe, one drachm to an ounce of water.

Regarding the permanency of prints so fixed, there is every reason to entertain the hope that they will be more stable than those treated with hyposulphite of soda. It is barely six months since we commenced our experiments. The pictures then fixed do not, however, show the slightest sign of change. M. Meynier informs us that he has used this salt for twelve months, without the slightest trace of yellow or fading having been found in any of the prints, whilst some fixed at the same time in hyposulphite of soda, show unmistakable traces of yellow in the lights. He adds, he is satisfied that as soon as photographers discover all the advantages of sulpho-cyanide of ammonium, hyposulphite of soda will be banished from their establishments.

We have not yet had time to try the method of toning suggested by M. Meynier; but we can readily conceive it to be desirable, if the new salt be used for fixing. We hope to try it shortly, and report further as to the results.

MAJOR RUSSELL'S RECENT MODIFICATIONS OF THE TANNIN PROCESS.*

WE resume our examination of the excellent manual of Major Russell.

THE TANNIN SOLUTION.—The original fifteen-grain solution of tannin has ceased to be regarded in any degree as of a standard strength. Major Russell finds in his later experiments that the strength may vary with advantage from two grains to thirty grains to the ounce, according to the subject. A strong solution gives great vigour and richness of tone; but slightly impairs sensitiveness. In some cases it has another singular effect. If the subject have much contrast and be very strongly lighted, a plate prepared with a strong tannin solution and iodized collodion gives a blurring of the lights which appear to encroach on the shadows. In such cases the use of a weaker solution of tannin is found to be a remedy. For well lighted landscapes a two-grain solution is recommended. The best proportion of tannin is to be decided by circumstances; as a rule, the feebler the image on the ground glass, the stronger should be the solution of tannin. "In no other process," Major Russell adds, "can the vigour and intensity of the picture be so easily regulated as in this, by varying the strength of the tannin solution." When the collodion contains bromide only, a larger amount of tannin may always be used with advantage, without any

* Continued from page 401

fear of producing the blurring referred to. Eight grains to the ounce may be used in such case with safety.

Regarding the quality of various samples of tannin it is observed that although much difference as to the degree of solubility is found in various commercial samples, in result the action is tolerably uniform. The chief difference in the various samples seems to consist in the amount of resinous matter they contain, which requires filtering out before use.

Two samples of tannin were forwarded by Mr. Williams, of Liverpool, one of which he found to yield less sensitiveness than the other, and likewise inferior results. Both samples were dissolved in water mixed with a little alcohol, but were not tried for several months: at the end of that time, on being examined, both solutions were clear and in good condition. The worse had thrown down a rather copious flocculent deposit, the better a slight deposit which adhered to the bottom of the phial. Several plates were prepared with each and tried carefully in pairs. Scarcely any difference appeared in the results; the worse sample seemed generally to have a slight advantage in sensitiveness, and there was a little difference in the colour of the images. It would appear from this that some samples of tannin contain an injurious impurity which is precipitated by keeping in solution.

For very full information on the preparation, keeping, and mode of applying the tannin solution, we refer our readers to the work itself, which deals very minutely with this subject.

EXPOSURE.—The question of exposure has always been regarded as a very important one in regard to all dry processes. Unless something like the rapidity of the wet collodion process could be secured it is doubtful whether what may be termed a semi-rapid process possesses any essential advantages over those which are known to be slow. If the exposure need to be one minute, for instance, it might as well be five. In some instances better. For if any object move across the field of view at a moderate pace during a five minutes' exposure, it will probably leave no impression on the plate; but if the exposure were one minute, the plate being five times more sensitive it is very probable a blurred mark, spoiling the picture, would be left by such a moving object. It is not the less, however, an important object to increase the capabilities of rapidity in dry plates, and Major Russell informs us that he has made great advances in this direction. On this subject he remarks as follows:—

With regard to the time of exposure, much difference will be found in the sensitiveness of the plates, according to the mode of preparation. The principal causes of insensitiveness have been already given; they are the use of a simply iodized collodion, or of an old sample, or the presence of more acid in the bath or collodion than is required to keep the pictures bright. Should two, or all of these unfavourable conditions be combined, the insensitiveness will be very great. The use of an alkaline, or impure bath, with a nearly or quite colourless collodion, will also produce insensitiveness to half-tones as well as fogging.

The writer has prepared plates by the method given in the preceding pages more sensitive than those he can produce by any other dry process with which he is acquainted, consistently with obtaining vigour and brightness, and he believes that this process will be found to give brilliant and vigorous results, combined with softness and good half-tones, with greater facility and certainty than any other process when the subject is feebly lighted; and if the tannin solution is of suitable strength no difficulty will probably be found with any kind of subject, especially when simply bromized collodion is used for such as are strongly lighted and present great contrast.

DEVELOPMENT.—If the plates have not received a preliminary coating it is better, before development, to paint round the edges with a solution of india-rubber. In moistening the film, Major Russell recommends the adoption of the suggestion made in our pages by Mr. Bartholomew, as to the use of dilute alcohol instead of water. He says:—

The use of diluted alcohol* instead of water to moisten the plate for development is a very great improvement in several ways; it prevents the expansion and consequent wrinkling and

* The writer is indebted to a correspondent of the PHOTOGRAPHIC NEWS for a knowledge of the fact that alcohol mixed with the water used to moisten will prevent expansion and loosening of the film.

loosening of the film to so great an extent that it is generally easy to work in this way without any previous coating, if the film of collodion is not very thick. When gelatine is used this mode of treatment enables us to work with a thinner solution, which is more easily applied, and less likely to permeate the collodion injuriously: it makes the feeble adhesion of a thin coat of india-rubber usually sufficient; but by far the most important advantage is this:—The alcohol, by its superior penetrating power, will restore the porous condition of the film when a very weak solution of tannin has been used, and even when the tannin has been washed off immediately after being applied; whereas, if the plate is moistened with water alone, the mechanical effect of a much larger amount of tannin is required, or the development will be very feeble; the chemical effect is then so great that, when the collodion contains iodide, it frequently renders the plate incapable of producing the best quality of negative with the kind of subject for which dry plates are most frequently used—landscapes with sky and dark objects.

In reference to the developer for general use, Major Russell adheres to the principle he originally published, keeping a stock of strong pyrogallie acid solution, and of citro-nitrate of silver, diluting and mixing these as occasion may suggest, as we have before described, and as he, in the edition before us, minutely details. Referring to the method of using pyrogallie acid solution alone for bringing out the image as first suggested by Mr. Wardley for collodio-albumin plates, Major Russell says:—

With some kinds of collodion the development may be started with pyrogallie alone; but with others, which have but little organic reaction, nothing can be brought out in this way. In some cases the pyrogallie seems actually to weaken the invisible impression, making the image, when brought out by the addition of silver, to appear less exposed than if the developer had contained a little silver from the first; when the pyrogallie is applied alone at first, however, the mixed developer usually keeps very clean. When a plate is under-exposed, a slight advantage may be gained by using the first portion of silver in the developer without acid: only a very slight trace can be used in this way. For this purpose, a drop or two of a ten-grain solution of nitrate may be diluted with half-an-ounce of distilled water, and a drop or two of this dilute solution mixed with the pyrogallie for a stereoscopic plate before applying for the first time to the film, the writer has not tested this plan sufficiently to be able to recommend it with confidence.

The use of formic acid in the developer appears to be attended with some advantages, both as regards shortening the exposure and rendering detail. The author observes:—

If formic acid is substituted for citric acid in the early stage of development, the details may be brought out and a soft picture produced after a shorter exposure, but the amount of advantage gained in this way has not yet been accurately determined. One part of pure formic acid of the strength sold retail at fourpence per ounce, may be mixed with from one to six parts of a twenty-grain solution of nitrate of silver. The mixture may be made in small quantity immediately before being used, but it has been found to work well after being kept in a bottle for some weeks in the dark room, although a slight deposit which adhered to the sides of the bottle was formed in a few hours. Formic acid keeps the imago and the developer clear very effectively, and, if used in larger proportion than necessary, it does not prevent the fainter impressions of light from coming out to the same extent as would citric acid under the same circumstances. Nitrate of silver solution, acidified with formic acid, works well without filtering, even after being long kept; it does not, however, produce intensity so readily as the citric acid and nitrate of silver solution; it will, therefore, be advisable to add a little of the latter to the developer to finish with.

The value of ammonia in development appears to be fully established, and is described here with much minuteness. It is another illustration of the singular coincidences that frequently happen, that the use of ammonia in development should have occurred to two or three persons simultaneously and independently. The announcement that diluted ammonia would develop a tannin plate was first published, we believe, in our columns, in a letter from Mr. Leahy, of Dublin. Major Russell, it appears, had, at the same time

(last autumn), been engaged in experiments which led him to the same conclusion; in both cases the American suggestion of fuming having led to the further discovery. Major Russell says:—

It has recently been discovered that ammonia may be used as a developing agent with dry plates. The writer, on reading an account of fuming tannin plates with ammonia in America, was led to investigate the subject. As it seemed probable that the developing effect was produced by some action on the tannin, the first thing done was to try the effect of ammonia on pyrogallie acid, which, being a much more unstable substance, was expected to act more strongly. This expectation was fully borne out by experiment; the mixture of a very small proportion of ammonia with pyrogallie solution produced no immediately visible effect, but after a short time the liquid began to discolour in the same way as if nitrate of silver and an acid had been mixed with it. If, immediately on being mixed, the liquid was poured on an exposed plate, a powerful developing action was set up, and when the necessary conditions had been found, it worked with great certainty. Further experiments showed that tannin, when mixed with ammonia, would act as a developer, but with less energy than pyrogallie, and that it therefore required a longer exposure. Gallic acid used in the same way appears to be intermediate in its effect between tannin and pyrogallie acid.

Fuming with ammonia has been tried. The effect with the tannin is greater than when the ammonia is applied in a liquid state, but still inferior to that with pyrogallie, for when the latter is added to the liquid used for moistening after the fuming, and poured on the plate, much more detail is brought out, and the result will then be much the same as if the ammonia had first been applied in liquid. The fuming does not seem to be so good a plan as the wet method, as it is more troublesome and uncertain, for in this way it is not easy to obtain exactly the right amount of the action of ammonia, and any great excess of this is injurious; if, on the other hand, the action is insufficient, very little effect will be produced unless ammonia is afterwards applied with the pyrogallie: the tendency to loosen the film appears to be about the same with both methods.

Commercial carbonate of ammonia answers better as a developing agent than solution of ammonia, for when the best proportion of each is used, it brings out the impression after an equally short exposure, with greater intensity, and keeps the picture rather brighter. If carbonate of ammonia is used, it may be kept in solution of any convenient strength; if solution of ammonia is used, one drop of the strongest usually sold may be mixed with one ounce of distilled water: for use, about the best proportion appears to be one grain to one grain and a half of the carbonate, or three-quarters of a drachm to one drachm of the diluted solution of ammonia, and one grain of pyrogallie in from two drachms to one ounce of the mixed developer. The strength of the developer within these limits will make but little difference, except that the stronger it is the quicker will be its action; if too strong, the transparent parts of the negative may be just perceptibly veiled; the more diluted the developer, on the other hand, the brighter will be the picture.

The plates may be moistened with diluted alcohol, in the manner already described for the acid silver development, and when the distilled water will flow freely it is to be poured off, and mixed with the carbonate of ammonia in solution, and then poured on and off the plate a few times. If the alcohol and water has acquired much tannin from use, this mixture will make a very good developer, and will bring out all the details, if a sufficiently long exposure has been given; if not, pour off the liquid, add the pyrogallie, and mix well, and return to the plate; the image will immediately show more detail and darken considerably, the image brought out by the tannin being paler and redder than that produced by the pyrogallie.

The following method of commencing the development is, perhaps, on the whole, better, certainly easier, but involves the expenditure of more alcohol:—Dissolve six grains of carbonate of ammonia in two ounces and a half of distilled water and one ounce and a half of alcohol, sp. gr. about .830 (1); this liquid may be kept ready mixed in a bottle. Dilute five minims of the alcoholic solution of pyrogallie* to two drachms

with the same proportions of alcohol and water as in the carbonate of ammonia solution (2). Measure out as much of (1) as will cover the plate (two drachms will be amply sufficient, if of stereoscopic size), and one-fourth the quantity of (2). Pour (1) over the dry plate on a levelling stand; it will flow freely, but still more so if a larger proportion of alcohol is used. Pour on and off two or three times, and watch the effect; if the tannin has been applied in weak solution, and especially if it has been washed off again, there will not be much developing action, but if the exposure has been sufficient there will usually be enough to give an indication as to the kind of treatment likely to be required. Next pour off and mix with (2), pour on again immediately, at the far side of the plate, carrying the measure along from end to end, with the foot turned from the plate, to prevent the possibility of dirty liquid falling on the film, and tilt the plate quickly, so as to drive off all remaining moisture before the mixture into the measure; in this way the development will be started evenly all over the plate. If the solutions of carbonate of ammonia and pyrogallie do not contain about the same proportion of alcohol, the mixed liquid will not flow freely. Pour on and off quickly two or three times, then let the plate remain at rest, covered with the developer, and carefully observe the effect.

If the appearance of the image indicates that the exposure has not been too great, the alkaline developer may be left to act for some time, but if the image shows symptoms of over-exposure, pour off and wash the plate quickly; in any case when the development with ammonia has been carried far enough, before intensifying with silver, the plate should be washed for several minutes under a stream of water, and then placed on a levelling stand, and left covered with water for a short time. After this the development may be completed with pyrogallie and acid silver, the proportions of which should be regulated by the appearance of the image, just as if the development had been commenced with the acid silver developer; by this means, and by varying the duration of the action of the alkaline developer, any error in the exposure can be corrected within certain limits. If, from under exposure, the alkaline developer fail to bring out sufficient detail, there appears to be no remedy; changing the developer for a fresh one of the same kind seems to be quite useless.

The acid development will bring out nothing which failed to appear before, and, therefore, very strong pyrogallie solution will not be needed; but by using at first a small quantity of silver solution which does not contain a very large proportion of acid, all the details faintly brought out by the alkaline developer will be established. By washing off quickly, and then intensifying with weak pyrogallie and a large proportion of acid silver, over-exposure can readily be corrected. The effect of varying the proportions of the pyrogallie and ammonia, to suit the development to the exposure, has been tried, but this plan does not seem to answer as well as the one just given. For landscapes, four grains of citric acid to each grain of nitrate will usually be required to prevent blurring, when the collodion contains iodide, as the tendency to this fault will be fully as great as if the development had been commenced with silver; for the same reason the plates should, in this case, have been prepared with as weak a solution of tannin as will work well.

If the exposure has been sufficient, the image comes out very quickly on the application of the pyrogallie and ammonia, and is at first of a more or less red tone, and has much the same appearance as if silver and acid had been used; the colour of the image soon becomes darker, the liquid darkening at the same time. If the plate has been rather under-exposed, the alkaline developer may be left on for many hours without producing any deposit or fogging, or the mottled markings so often brought out under similar circumstances by a developer containing silver; in this way, at last, a considerable amount of intensity may be obtained, by a reduction of silver so complete that the image will bear fixing with weak cyanide without being very perceptibly weakened. The intensity thus produced is of no practical value with bromo-iodized collodion, as it may be obtained in a few minutes to any desired extent by the use of the acid silver developer, and a better result will be thus obtained. With bromized collodion, if the exposure has been suitable, the alkaline developer will often produce sufficient intensity* without causing any bad effect if left to act for several hours, during which the plates require no attention.

* Pyrogallie acid	96 grains
Absolute alcohol	1 ounce
Ether	3 drops.

* In printing from negatives of low intensity, it is necessary to use highly

The interesting subject of alkaline development is entered into with considerably more detail, and we strongly recommend our readers to study the chapter in Major Russell's book. Hot development has not been successful in Major Russell's hands, and he does not recommend it, as although he finds that an image may be forced out by its aid after short exposure, he finds it to be superficial and generally worthless.

Fixing.—The author prefers hyposulphite of soda to cyanide of potassium, as a rule, on account of the tendency of the latter to loosen the film.

Both in the course of the work and in a final chapter the various suggestions which have been made for modifying the tanning process are considered. Applying the tannin solution without removing the nitrate of silver, is found to give stains. Washing after applying the tannin solution is found to increase sensitiveness. Gum used with tannin has a tendency to cause blisters and fogging, but increases sensitiveness. Mr. Keene's method of applying gum and tannin without washing away the free nitrate, may be used, provided sufficient formic acid be added to the preservative, but no accession of sensitiveness is gained by the presence of the free nitrate. Honey and tannin are found to work well, but the advantage of the honey is only found in hot dry weather. The addition of dextrine causes loss of sensitiveness and loosening of the film. The addition of glycerine gives no advantage in winter, but may be useful in hot dry weather. Indeed, whilst tannin may be used in conjunction with a great many other preservatives, almost everything which has been tried has had, in Major Russell's hands, the effect of blurring the edges of the lights, or of diminishing sensitiveness, or of loosening the film, or of being altogether neutral in producing results.

We strongly commend our readers to obtain this little volume, which is full of suggestion, the result of much experience, and the most careful observation of, and reflection upon, the varied phenomena, presented by dry plate photography.

SENSITIVE PLATES AND THE CUSTOM HOUSE.

THE question is frequently raised by intending tourists on the continent as to what facilities exist for sensitive plates passing the various continental custom houses without being exposed to light. We have been asked recently whether any special facilities would be afforded for sending English contributions to compete for the Marseilles rapid dry plate prize. Regarding the latter we have written to M. Vidal, the Secretary, and have not yet received any answer*; but as the general question is an interesting one, and has not, as yet been placed upon any definitely understood footing, we have pleasure in publishing a letter we have just received from Mr. Cole, detailing his experiences in this direction.

The box which he kindly forwarded for our inspection, affords every facility for examination without any risk to the plates. The four pieces of glass, each about two inches square, are of a very deep green, and placed opposite each other, so that the light passes right through. We append copies of the inscriptions, one in French, and the other in Italian, to be placed on each box, for the benefit of those who may be desirous of following out the method Mr. Cole has found successful:—

salting paper and some method of toning which reduces considerably. In all cases the darkest parts must reach or nearly approach the bronzing stage, or the positive will be wanting in vigour; with a faint negative, by the time that the shadows are deep enough, the most opaque parts will be printed through. A toning mixture which has sufficient bleaching power will clear the lights of the picture without reducing the shadows too much, and so produce a brilliant positive from a somewhat weak negative. This is perhaps the best way of working, for it is much easier to obtain a good negative of low than of high intensity, the gradation of tone being often injured when intensifying is carried far. No time is lost in this way, as faint negatives print very quickly.

* We have received a communication from M. Vidal, just at the moment we go to press. It shall appear in our next.—ED.

Cette boîte contient des plaques photographiques très altérables à la lumière ordinaire; si elle est ouverte au grand air, les plaques seront complètement perdues.

Messieurs les officiers de la Douane sont, des-lors priés d'avoir la bonté, de regarder dans l'intérieur, au travers des verres de couleur, qui y ont été adaptés exprès pour faciliter la vérification; et ils pourront par là aisément se convaincre, que la boîte ne contient, ni cigares ni aucun autre objet de contrebande.

Questa cassetta contiene vetri preparati per la fotografia facilissimi a quastarsi al contatto dell'aria.

Se la cassetta viene aperta essi sono intieramente rovinati.

Si prega l'officiate della Dogana ad avere la bontà di osseroare a traverso dei vetri colorati, e vedrà che la cassetta non contiene nè sigari, nè altri oggetti di contrebande.

DEAR SIR,—As to sensitive plates reaching Marseilles unexposed at the Custom Houses, and as the time for tourists is come—yet more because you say you will make inquiry—I venture, unasked, to send you a plate-box which has passed the ordeal, with several others, through France, Switzerland, and Lombardy. All were sent from Turin by Diligence home before me, with key attached, and upon development they certainly had not suffered from Custom House officers' inspection. In both the top and bottom of the box are let in two pieces of yellow glass, about 2½ in. by 1½ in., and 3 in. apart, in rebates, and secured by small deal slips (any carpenter can do this). Outside of the yellow is a piece of green, rather loosely fixed by ordinary stout needle-points. This I put to take any blow, and get crushed instead of the yellow. Pasted on the side of the box is a request in French and also Italian, to Messieurs les officiers, to have the goodness to look through the yellow glass, and see that the box contained no cigars nor other contraband; and look through, they always did, upon reading the civil request and the reason for making it. An eminent Photographic house having seen one of my foreign boxes, has, I believe, copied these petitions into their year book (possibly with better French), but I think, unfortunately, without telling that the arrangement has actually stood the test in anybody's hands, which is the very thing that your subscribers would, perhaps, like to know. You yourself may find better means of security. I only think you will allow me to send my contribution.

You will see that I have used boxes for six only. An official will not lift to a gas light a dozen box of 12 by 10's. Besides, these require no handles, and therefore pack pleasantly, and, as breakage occurs, it is better to lose a few than so many, from the ramblings of a fragment of glass.

If I may write on, I would say that long railway and diligence shaking so often causes the glass edges to part with small bits or dust to travel over the film, and that as tight packing inside the cover will be sure to crack a plate on the first throw off on to a platform, I should, another time, ask Messrs. Bland to make the boxes with covers at the bottom (it sounds Irish) as well as at the top, so that all four corners of the plates may be got at and wedged with cardboard, to keep them free from the grooves. And commend me to a box with the extra 1s. 6d. expense of two locks and one key, instead of those hooks which always will get loose when one wants the ends to be the tightest.

To repeat, do not omit the green glass protection; it is agreeable to the foreign eye to look through green spectacles. I will, at all risks, add that I kept each box in a loose yellow calico case, as extra protection from light, and I found that the opening it gave time for a polite caution and a polite acquiescence. It was in 1861; every year would afford increased attention to photographic plates probably.—Yours truly,

JOHN J. COLE.

24, Essex Street, Strand, 24th Aug. 1863.

PHOTOGRAPHY IN AUSTRALIA.

BY PAUL RICOCHET.

THE "old folks at home" know, for the most part, very little about the colonies. Those among them who are considered well read on the subject, have at best only a hazy idea of the actual state of matters at the antipodes. A dim vision floats across their mental sight, of a wilderness of sheep-stations, where hardy bushmen (subsisting chiefly on kangaroos) dwell armed to the teeth against the frequent attacks of hostile natives.

Also, it is difficult to make people understand that Melbourne is *not* in the same island as Hobarton, and that the towns on the continent are *not* within an hour's walk of each other.

"Ah! Mr. Ricochet," said a lady to me once, "I hear you intend making a voyage to Melbourne. I wish, during your stay there, you would call on my son, he would be so pleased to see one of my old friends."

"Delighted to do so my dear madam. What is his address?"

"7, George Street, Rockhampton!"

Now, Rockhampton is just one thousand miles from Melbourne, rather too far for a morning call!

As may be gathered from the foregoing conversation, I had at that time an idea of taking a trip to the colonies, and this idea was carried into execution some two years ago.

The following paragraphs contain a few extracts from notes taken during the trip, and may probably interest the readers of the PHOTOGRAPHIC NEWS.

"Tannin" not being then in vogue, I provided myself with a tent, wherein was found every requisite for working the wet process in the field, and having packed up therewith a 9 × 7 instrument, with single and double combinations of lenses, and all necessary chemicals, started by one of the Blackwall Liners, in which a pleasant voyage passed without accident.

On Tuesday, November 17, 1861, I had my first view of Australia.

A long low stretch of rugged coast, extending on either bow as far as the eye could reach, the monotonous grey rocks broken into an opening ahead, where two cliffs formed the gate posts of a line of surf, inside which could be seen for many miles, a vast expanse of calm water,—Hobson's Bay. The same evening, we arrived at Sandridge Pier.

To one coming from London, Melbourne presents few remarkable features. It is in fact, as many declare, a miniature London. The same 'buses, cabs, and vans throng the streets, morning, noon, and night, and the diurnal clatter and roll of wheels is well nigh as deafening as in any section of the modern Babylon.

Nor is the resemblance less striking in the matter of photography. Every second house in the street is either a photographic shop, studio, or warehouse; and yet, with all this competition, the profits made by some of the leading houses are enormous. One can get one's "carte" as well taken here as in London, at any price from 3d. to 10s.

I did not notice much *landscape* photography going on, even amongst amateurs. The truth is, Melbourne and its suburbs are hardly picturesque enough to tempt even the most enthusiastic devotee of his art. There is scarcely a decent view anywhere—the country is flat, tame, and uninteresting.

After a few weeks in Melbourne, I determined to take a trip over to Tasmania, and spend some time amongst the varied mountainous scenery with which the island abounds. For this purpose, starting one afternoon by steamer, I arrived in Hobarton just forty-eight hours after leaving the Melbourne wharf.

It was early in a fresh spring morning as we passed at half speed up Storm Bay, going close to the lighthouse at the entrance of the river Derwent, which lighthouse, by the way, bears the euphonious name of the "Iron Pot," whether in delicate allusion to its architecture, or not, I could not learn.

Rounding a point in the river, we came in sight of Hobarton. Mount Wellington, rising steeply some 4500 feet above the water, forms a grand background to the town, whose white houses, mingled with tufts of lofty trees, are sprinkled over several small rises along a bend in the Derwent; points, thickly clothed with dusky foliage, jut out from either bank, and the whole landscape, surrounded and shut in by ranges of hills, and reflected deeply in the broad, calm bosom of the river (which is here three miles wide) formed a picture I had rarely seen equalled.

My first care, after securing lodgings and a man to look after my concerns, was to ransack my photographic packages. Everything was in perfect order; the collodion (principally Bland and Long's), had stood the voyage famously. By the way, let me here recommend all tourists by sea voyage to carry their instruments and chemicals in air-tight tin boxes soldered carefully up. If this precaution be attended to, the risk of danger is small.

Although I was well satisfied at having brought with me all necessary chemicals; there was in fact no actual necessity for so doing, as chemicals by all well-known makers can be bought in Melbourne. In Hobarton too, one can now, I believe, get any requisite; but at the time of my visit there was no first-rate photographic warehouse established there.

Every one advised me to ascend Mount Wellington; and as my own inclination coincided with the advice, and as my servant (an Irishman, by name O'Corcoran), professed himself thoroughly well acquainted with the route, I started one fine morning on this my first photographic essay in Tasmania.

Mr. O'Corcoran and myself trudged merrily along, he with the tent and chemicals, and I with the instrument. After a couple of hours walking along a steep stony track, we reached a terrace called the "Springs," which is considered half way to the summit. Here a rivulet of cool, clear water issues from a rocky cavern, and falls away down the mountain side. This cavern, with overhanging shrubs and brushwood, formed a charming subject for the camera. I was disappointed in not getting the view from this spot of the town and surrounding country, which is very fine. My failure was, I believe, owing to the too strong contrast between the foreground, which was dark and sombre, and the distance, which was very bright.

In this trip I gained several experiences. One was that the wet process, with a tent, is nearly useless in Australian photography. With the thermometer at 98° in the shade, the interior of a tent is like the *sudatorium* in a Roman bath; and added to this, there are frequent hot winds, which cover your plates with fine dust, and often blow the tent over.

What strikes an English photographer very forcibly in Tasmania, is the translucency of the atmosphere. On this account distances, even when remote, may be photographed with remarkable distinctness and perfect definition. I never saw a country so free from fogs of all kinds; indeed, the only fog I ever saw there was once on a swamp, and in that case it covered so small an extent of ground, that when one walked for fifty or a hundred yards up any one of the surrounding hills, one could see the fog lying like a tuft of cotton wool on the little swamp below.

After spending a month pleasantly in Hobarton, I packed up my traps, and began my travels through the island. Warned by previous mishaps, I left my cumbersome tent at home, taking instead a store of collodio-albumenized plates, warranted to keep "any length of time."

I was rather successful with this kind of plate. I found their keeping qualities equal to my wants: for instance, I managed to keep them, when sensitized, for upwards of five weeks, which, in a hot climate, is a term not to be despised. My formulae were as follows:—For the iodized albumen, dissolve 7½ drachms loaf sugar, 36 grains iodide of potassium, 36 grains iodide of ammonium, and a scale of pure iodine, about the size of a barleycorn in 9 ounces of distilled water. Add to this solution the white of 9 eggs, and beat the whole into a firm froth. I preferred the eggs not quite fresh, believing that when in this condition, the film produced was less likely to blister. I used any old collodion, a forty-grain nitrate bath, and great care in cleaning the plates. Also, copious washings* at every stage of the process.

(To be continued.)

* I found using half a dozen buckets filled with water, each in succession as dipping baths, an excellent plan.

PHOTOLITHOGRAPHY.

II.

BY JOSEPH LEWIS.

VARIOUS METHODS OF OBTAINING AN IMAGE ON STONE.

THE desideratum in photolithography is to obtain a permanent impression on the stone or plate from which to print the copies; in fact, to assimilate the process as nearly as possible to that of transferring in the usual course of the lithographic art.

By the process of photo-printing from stone with direct application of the sensitive film to the stone's surface, we fail to get perfect results, owing to its very absorptive nature, for having once imbibed even a soluble substance, it is difficult to extract or dislodge it. For this reason I failed, in 1842, to produce perfect results by the use of bichromate and gum on stone, as also the bitumens. I then had recourse to the following expedient.

I coated the surface of a card with hard plate ink, this I brushed over with very finely divided pure silver powder or dust, and then passed the card through press on a polished steel plate. I produced the picture by the ordinary daguerreotype process, as if it were a silver plate. The picture thus obtained only remains to be etched by the galvanic influence, when the shadows, consisting of pure silver, are quickly etched away, exposing the transfer ink in deep contrast with the mercurial deposit, comprising the lights of the image. This, when washed in a solution of cyanide of potassium, and in water, and dried, is laid, face down, upon a clean, heated lithographic stone (brass, zinc, or iron plate answering also for the purpose), and passed through the press, when, as will be readily understood, the ink is pressed into close contact with the stone, and is absorbed by it, but the deposit of undissolved silver and mercury on the lights intervenes to prevent the ink under those portions from contact with the stone. We have thus a reliable transfer wherein every mark or indication is permanently fixed in the stone and capable of great endurance in course of printing, for this plain reason—the surface of the stone is perfectly clean and the ink substantially greasy.

Closely connected with the above manner of manipulation, and also with the process described in last week's number of the NEWS, is the following process, which possesses peculiar advantages, being more sensitive than the latter, and more simple in its application.

I form a jelly, consisting of four ounces of water, one ounce of gelatine, one-eighth of an ounce of glycerine, and bichromate to saturation at a temperature of 80 degrees. These are put into a glue-pot, and heat applied to dissolve—carefully filtered and spread on glass plates—then allowed to stiffen until the surface will not adhere to the dry finger, or stick to the negative plate when pressed against it. If the upper surface be not smooth, I reverse the film upon another plate or waterproofed cardboard, upon this I place the negative and expose for a few minutes according to light, and then withdraw to the dark. The exposed surface is to be laid down on a clean lithographic stone, and a very gentle pressure applied simultaneously on every part to ensure success. Some dexterity is required in laying down and quickly taking up the gelatine sheet, circumstances regulating the degree of pressure and the time it should remain in contact with the stone. This being accomplished, the stone is smeared with re-transfer or printing ink, and washed off with turpentine and gum-water; then inked up in the usual manner. A positive transfer will be the result, ready for printing. The same exposed surface may be placed on several stones, and yields a number of good transfers by a single exposure.

On comparing this process with that described in last week's issue, it will be seen that there is a connecting link, being opposites in every particular, except that they unite in giving a resultant positive image as a printing

surface. By the former, the actinic influence "stops out" the lights on the picture; in the present process the lights are procured in proportion to the intensity of the exposure. By each the exact sum of actinic result is preserved and deposited on the stone, whereby we obtain the natural amount of gradation and detail.

I repudiate as steps in the wrong direction, the various futile expedients recommended to produce a "grain" on the stone or plate, to obtain by artificial means that which nature itself can so effectually supply. There is no grain or roughness needed on the daguerreotype plate or the collodion film, yet there is absolutely perfect gradation. The only result of any attempt in that direction has been to destroy minute detail, and break up or destroy the intensity of the shadows, as may be seen by an inspection of the phototypic proofs.

PHOTOGRAPHY AS AN ACCOMPLISHMENT.

BY REV. S. MILLER.*

WE employ professors, and pay them well—some more than they deserve, others little enough—to give lessons to our daughters in music, drawing, and painting. These are desirable accomplishments for young ladies, provided something more than mere dabbling in them is attained, which is seldom enough the case. Hence, after leaving school, their productions seldom see the light of day, and there is no one to admire them. Just compare some of their best productions with the fine pictures, so life-like and true to nature, which any lady is able to produce by means of the camera, in half the time and at half the expense lavished on her other accomplishments, and you will be surprised at the vast difference.

There is no reason why photography should not be introduced and taught as a female accomplishment. There would be something real in such an accomplishment, producing infinitely more pleasure and admiration than any of the imperfect productions by means of brush and pencil.

A piano and a camera. A family parlour and a family gallery. A library and a laboratory. Your dear friends from abroad come to see you, and you part with them perhaps for the last time. They are gone, but before they got away you caught and fixed their lovely image in your camera, and you keep that instead of their presence. You make a rare and beautiful collection of the portraits of living and departed friends—a family gallery of pictures; and it is *all your own production!* What pleasure in the thought. And you need not blush to let them be seen by your visitors and friends, nor indeed by any of the best artists. They are the productions of real art and the most beautiful art which you can practice.

I am teaching my daughters and sons the art, and I mean that my family shall possess the best instruments and materials to practice it. It affords them already a great deal of pleasure, and makes home sweeter and more attractive than anything else that I have yet introduced in the way of rational amusement. Louisa, the oldest, is very successful in taking the finest portraits on glass. Master Charley is a real little artist, and takes first-class card pictures, equal to some of the best produced in large establishments. He reads and loves *Humphrey's Journal*, and is ever on the alert for some new experiment. I herewith enclose you some of his proofs, one the portrait of his sister Phene. She, too, is beginning to show her hand, and has succeeded in producing some beautiful ambrotypes. And Clara and George are impatient to try their hand. It not only affords them much pleasure, but may prove a benefit to some of them hereafter.

In this connection I must relate quite an unexpected and very important "result." The oldest daughter, Louisa, who has somewhat of an enterprising spirit, took it into her head to try the experiment to operate for the public. A

* From *Humphrey's Journal*.

vacancy occurred in a neighbouring town, in the heart of our extensive coal region, and I was requested to send them an operator, as pictures were much in demand. She was determined to go, more for the novelty and excitement of the thing than any profit she expected to reap. To gratify her anxious desire to try the experiment I had to part with my instruments for a time, hoping she would soon get tired.

She made her temporary home at the principal hotel in the place, and I introduced her as a minister's daughter to the landlady and a clergyman boarder, the Episcopal minister of the place, who promised to take good care of her.

She succeeded remarkably well for a time, myself having seen that her bath and collodion were in good working order, and she took the portraits of her customers, both young and old, to their mutual satisfaction. She was rapidly gaining the reputation of being a good artist, and customers increased from day to day. But in taking the portraits of the clergyman and a certain member of a corps of engineers, who were locating a new railroad in the neighbourhood, she got fairly "stuck." They both fell desperately in love with her, and the only way to get out of the "difficulty" was to refuse the one and accept the other. The "result" of her experiment as a practical operator was a wedding, the ceremony of which was duly performed by the father of the bride in presence of his congregation. The result proved highly satisfactory all round, except to the disappointed party.

Her husband, immediately after the wedding, put a "stop" to his wife's operation as a photographer, insisting that "she didn't gain anything by it." "Didn't gain anything by it," she replied, "didn't I gain a husband by it?" He had to admit the fact, but allowed that quite sufficient, to which she finally agreed; so I got back my instruments to make other experiments, the results of which are not quite so romantic, but some of them nevertheless worth recording.

ALBUMENIZED GLASS PROCESS.

BY CHARLES WALDACK.*

I HAD occasion a short time ago to see some stereoscopic slides made, by the albumen process, by Mr. Ferrier, in Paris, and I was so much struck by their beauty and fineness, that I have ever since been in a fit of enthusiasm about them. That the process by which they are made presents incontestable advantages over all others, for such kinds of work, cannot be denied by any one acquainted with its results. The objection is urged against it, that it is of great difficulty in execution—that it is difficult to get an even film of albumen, to avoid dust, &c.; and these fancied difficulties have led to its being practised only by a very small number of photographers. Now, I have had occasion to hear the story of successful practitioners of the process, and they assert that these difficulties have been much exaggerated, and that with a little practice it is just as easily worked as the collodion process.

This has encouraged me to give your readers a description of the process practised by Mr. Ferrier, as communicated to me by a friend.

Take 20 oz. of the whites of fresh eggs, out of which the germ has been removed, and add to it 100 grains of iodide of potassium and 5 grains of iodine previously dissolved in a little water; beat in the ordinary way. If you don't know how, consult any work on photography. Our formula stands thus:—

Albumen	20 fluid ounces
Iodide of potassium	100 grains
Dry iodine	5 grains.

Clean out your room the day before, not only the floor

* From *Humphrey's Journal*.

but also the walls, sables, &c., and in the morning sprinkle with water. Now, have a large alcohol lamp or several small ones, or—what is better yet—a gas lamp such as is used for cooking by gas (Bunsen's lamp); put a support over it, and lay on top a thick sheet of iron plate. The glass, being well cleaned, is coated with the well deposited albumen. This is done in the following way:—Condense the moisture of the breath upon it, and pour on albumen in the same way as collodion, pouring the excess into another bottle. Breathe again on the parts which are not yet recovered, and pour a fresh portion of albumen on those parts. Obtaining in this way a film all over the glass, the excess is drained off, and the plate is hung by its corners on four silken threads of equal length, having a hook at one of their ends; the other end of the threads being held in the hand, the plate is kept over the hot sheet of iron and a rotatory motion is given to it. The albumen is spread evenly all over the glass by the centrifugal force, and the drying is accelerated both by the heat and by the motion. Very few minutes are necessary to dry a plate in this way. When dry it is put into a grooved box and another one coated. The sensitizing is done in the following solution:—

Distilled water	14 ounces
Nitrate of silver	1 "
Glacial acetic acid	2 "
Iodide of potassium	2 grains.

The bath is prepared the same as for collodion. I suppose 6 oz. of acetic acid, No. 8, may be substituted for 2 oz. glacial, using then only 10 instead of 14 oz. of water. The sensitizing is done in from 15 seconds to 1 minute. The plate is then washed under a tap and put to soak in clean water. Any other way of washing used for dry collodion will answer. After being well deprived of its nitrate of silver, the plate is set to dry and placed in a grooved box in the dark room.

I have not been informed how long the plates thus prepared remain sensitive. However, I know they can be used several days after, and suppose they will keep as long as any dry collodion plate if well freed from the nitrate of silver.

The exposure is about the same as in the tannin process, when old collodion is used perhaps somewhat longer. The development is done as soon after the exposure as possible. The plate, if exposed long enough, shows traces of an image before development. This operation is carried on in the following way:—Make a solution of gallic acid, 1 grain to the ounce; pour it into a vertical glass bath, and set the bath in warm sand at 120° Fab; the plate is then put into it, and left there for one or two hours. This is done to soften the albumen film. After that it is put into another vertical bath containing a cold solution of gallic acid to which 5 or 6 drops of fresh silver solution have been added. In this bath the plate develops rapidly, and when the image has almost entirely appeared take it out for a moment, and add to the gallic acid 3 or 4 drachms more of silver solution. The plate being dipped again, the image acquires its greatest vigour and is washed and fixed with hyposulphite of soda.

The operator should well convince himself of the fact that the colour of an albumen negative obstructs the actinic rays more than that of a collodion negative, and that, in consequence, the deposit need not be so dense.

Transparent slides are made by exposing an albumen plate under a negative for a few seconds to the light of the sun. The pleasing colour of Mr. Ferrier's slides is given by dipping the finished positive into a weak solution of bichloride of mercury, washing it, and then dipping it into a solution of chloride of gold, 1 grain to the oz.

If I have thus returned to this old and much abused process, it is, Mr. Editor, because I think it may prove profitable to your readers. If any of them have an opportunity of seeing some of Mr. Ferrier's slides, I am certain that they will be of the same opinion as I am about them—that nothing on either wet or dry collodion can compare with them.

THE NEW GOLD TONING BATH.

BY REV. S. MILLER.*

I HAVE long since felt that the gold toning bath neutralized by means of carbonate of soda, or in which any of the sodas are added for any purpose whatever, could not give permanent satisfaction. The loss of gold for photographic purposes by precipitation, and the inconvenience in manipulations, especially the former, was to me at least a very serious objection, and I felt satisfied in my own mind that there must exist a possibility to overcome this expensive waste by neutralizing the gold by means of a substance that would not cause its precipitation. In this, it seems, I have not been disappointed. Others have been exercised on the same subject, and have laboured successfully to overcome the evil. The remedy is found. I have tried the experiment with perfect success, and I cannot express how thankful I feel for the information I have derived from the pages of the Journal on this important subject. It pays me double the price in gold for the last three volumes. In my humble opinion, the time is come when the use of soda in the toning bath is entirely and for ever done away with, provided amateurs and operators will furnish themselves with the proper sources of information, such as *Humphrey's Journal* affords.

I will state my experience in this new process, and the peculiar mode of operation which I have adopted as the most convenient I could think of.

1.—I commenced by making a saturated solution of lime, half an ounce to 16 ounces of water, which contains about 15 grains to the ounce of solution. The bottle containing it is labelled accordingly.

2.—In another bottle I made the following solution: I dissolved 30 grains of commercial chloride of gold, pretty strongly acid, in 30 ounces of water, and added 30 grains of finely pulverized carbonate of lime (common chalk). This was well shaken and left standing for half an hour. To this was added 2 ounces of the above chloride of lime solution, containing about 30 grains. The whole was then filtered. This solution has a slightly alkaline reaction. None of the gold is precipitated, nor has the calcium materially changed its golden colour. This, however, is not the toning bath. The bottle containing it is labelled "gold and lime solution," and the foregoing formula added.

3.—Fifteen ounces of the above gold and lime solution are poured into a half-gallon bottle, and 30 ounces of water added. This is the standard toning bath, containing 15 grains of chloride of gold, 15 grains of carbonate of lime, 15 grains of chloride of lime, and 45 ounces of water. Perhaps a larger quantity of water would be better, as the bath is at this standard very vigorous. It does not require filtering. By the addition of water the gold solution has become almost entirely colourless, clear, and transparent, without the least deposit or precipitation. It is in appearance the next thing to a nitrate of silver bath, and I propose to treat it much in the same way.

4.—There are still 15 ounces of the gold and lime solution left, which is set aside ready for future use as occasion may require. When the bath becomes weak by use, one or two ounces of this solution is added to keep up its uniform standard.

The prints are thoroughly washed before putting them in the bath. They tone quickly, more so than when the bath is neutralized with soda. The toning does not materially bleach the prints, but the subsequent fixing does; for which reason the proofs have to be overprinted as usual. After fixing in fresh hyposulphite of soda, washing, and drying, the tones are a "rich deep black, quite free from meanness, blueness, or slateness in the shadows," &c. If not overtoned, they are unsurpassed by any results that I have yet produced by any other toning process.

What effect age will have on the foregoing concentrated "gold and lime solution," as a very ready and convenient means of keeping up the standard strength of the bath, I have not had time to test. But if time does not produce a change in the bath, the presumption is that it will not affect the gold and lime solution, probably even less than the diluted bath. If such be the case, and if no other objection will arise against the substitution of lime for soda, then indeed have we obtained the most convenient, the most effective, and the most economical process of toning with gold that can well be conceived.

* From *Humphrey's Journal*.

In a subsequent article the same writer says:—

As others intend to give the new gold toning bath a fair trial, and have questioned me in regard to my process of preparing it and its results, by private correspondence, I would state, for their information, that the bath I have prepared and kept up to its standard strength, according to the formulas given in my article of the 1st of March, has now been in daily use in my son's operating room for the last six or seven weeks with uniform good results. I find no occasion to make any change, except to renew the chloride solution, in consequence of not having kept it in a well stoppered bottle, by which neglect much of its chlorine has escaped, and chloride of calcium was formed. I would recommend that all the solutions, even the bath when not in use, as well as the dry chloride of lime, be kept in well stoppered bottles, to retain as much as possible their peculiar smell, which indicates the presence of the chlorine.

In this connection I would also correct a slip of the pen, which, though it does not affect the formula itself, has, nevertheless, made a wrong impression on the minds of some. In describing solution No. 1, the word "saturated" should not have occurred. The article I use is not the chloride of calcium. This compound, although entirely soluble in water, is a different and very inferior article. I use the chlorinated lime, the fumigating and bleaching agent of commerce, usually called chloride of lime. The article sold by druggists answers the purpose very well, but a more perfect and purer article could be produced, almost entirely soluble in water, which would answer photographic purposes still better, as it would contain more of the chlorine and retain it longer. It is true that chloride of calcium is present in the bath; but this, according to Omneganck (*vide* number for February of this journal), is formed by the free acid of the chloride of gold and a small portion of its chlorine combining with the carbonate of lime, the gold retaining the greater portion of its chlorine, whereby its precipitation is prevented.

Chloride of calcium is likewise formed when the chlorine of the lime escapes. The rationale why chloride of lime is added in addition to the carbonate of lime which of itself in sufficient quantity is able to produce the required alkalinity, is not given, but we are assured that it works well, and such I have found to be the case. It seems that the chlorine thus super-added to the chloride of gold, has something to do with the vigour of the bath and the brilliancy of the results produced. Hence the necessity of preventing the escape of the chlorine by useless exposure.

Great care has to be taken in the use of this process, that none of the fixing solution gets into the bath, or the whole is in danger of being ruined, as the hyposulphite of soda liberates the gold of its chlorine and precipitates it to the bottom. It is not only necessary to have the hands clean and free from soda before dipping them in the bath, but likewise in washing the prints before toning, and not to use a vessel for this purpose, in which prints after fixing had been soaked, without thoroughly cleaning it. We are apt unconsciously to carry the soda adhering to the hands or vessel into the water where prints are washed, where it will affect and impair the prints, and thence, adhering to the prints and hands, carry it to the toning bath, where it will, at first imperceptibly, but gradually and surely, do its destructive work.

I mention this fact, not only to save the bath, but to remind the operator that, if at any time his gold begins to precipitate, he can rest assured that the cause is to be ascribed to the old arch-enemy of all toning baths. He cannot be too closely guarded against, and should ever be kept at a respectable distance from the bath, until we can get entirely rid of him even as a fixing agent, and vote him out of every operating room in the land.

If by any accident soda should get into the portion of the bath in the toning dish, and evidence of precipitation appear, do not pour it back into the stock bottle if you value the rest of your bath.

If, in washing the prints, they become yellow and dirty, it is an evidence that they have been affected by soda either in washing or handling. Do not immerse the nasty things in your precious toning bath.

To keep the bath nice and clean, free from dirt and the effects of imperfect washing of the prints, filter the contents of the dish after toning back through a funnel, and your bath will remain clear and transparent.

I will yet add that it is presumed that those who will give the new process a fair trial are aware of one of the principal secrets of good toning, and that is, not to be niggardly in the use of gold. This process does not warrant the use of gold less freely than any other; but it saves the useless waste of the precious metal for photographic purposes, and greatly facilitates the manipulation, as you are not under the necessity of preparing a new bath daily for every batch of prints to be toned, and then be compelled to see with a sorrowful face the remaining gold go down, down to the bottom with its sulphureous enemy.

The attempt of saying it in other processes, by using it nearly all up in toning, is at the expense of uniformity of results; and as to using it all up before precipitation begins, that is simply out of the question. In the new process none of the gold is precipitated, and its uniform strength is kept up, hence the results are uniformly good, saving, in addition to its other superior advantages, much waste in paper, silver, and time, which are otherwise lost, because a weakened bath refuses to perform what does not lie in its power. Being given over to the power of its deadly enemy from the beginning of its existence, and its short life of an hour already in the throes of dissolution—poor thing; how can it help it? Save your bath from his clutches, and you will be all right. Give the new bath a fair trial, and keep him at a distance, and it will live to speak for itself, when all other processes in which he has his fingers are dead, and gone with him to the place from which there is no returning for evermore.

Correspondence.

FOREIGN SCIENCE.

[FROM OUR SPECIAL CORRESPONDENT.]

Paris, 26th August, 1863.

M. DAVANNE has called the attention of our Photographic Society to the advantages offered by the employment of sulpho-cyanide of ammonium. The observations he communicated are the result of experiments performed by M. Lewitsky and himself. Both have for several months made almost exclusive use of this new salt. They have proved that if it is slower in action than hyposulphite, it does not attack the thinnest film of silver deposited, and that the proofs fixed by it are superior to those treated with cyanide. M. Lewitsky recommends the employment of a very strong solution, containing at least 50 per cent. of the salt. M. Davanne applied this mode of fixing to *clichés* upon albumenized collodion (Taupenot's process) specially, and in consequence had nothing to fear from the albumen curling up, as was frequently the case previously. Practice, therefore, confirms the hopes that early experiments raised, and as M. Davanne observed, the great reduction in price already made by manufacturers, secures an extended use for this product.

M. Davanne adds, that sulpho-cyanide of potassium possesses the same qualities as the salt of ammonium, without any of the inconveniences attendant upon the latter.

M. Colombi, an optician, has exhibited to the Society an enlarging apparatus without reflector, which, he assures us, yields positive proofs in three minutes.

M. Morvan has addressed to the Academy of Sciences a note, accompanied with specimens of a new photolithographic process, which he describes as follows:—"Upon a lithographic stone, previously coated, in a dark place, with a varnish composed of albumen and bichromate of ammonia, I place the right side of the subject to be reproduced, whether the picture be upon glass, linen, or paper. Papier Saxe is naturally to be preferred. But any other sufficiently transparent substance suffices for this operation. This done, I expose the stone to the action of light, from 30 seconds to 2 or 3 minutes only, if in the sunshine; and from 10 to 15 minutes, at the most, if in the shade. At the end of this brief time, I remove the subject and wash the stone, at first in soap water, and next in pure water, and I immediately

pass over it an inking roller. The design is already fixed, for the picture begins to reveal itself in black upon a white ground. Then I gum it, and leave it some minutes to dry, and the operation is concluded; we can then pass it through the press and print from it.

"It will be understood that the light fixes the varnish and renders it insoluble wherever it strikes upon it; but that, on the other hand, all those parts of the stone shaded by the lines of the original design, remain soluble, consequently attackable by soda and by acid, in addition to what the substance of the soap contains; the action here produced upon the stone belongs at the same time to engraving and to lithography.

"As to the advantages of the process, they may be summed up as follows: simplicity and rapidity of operation; exactitude of reproduction; no need of *negative clichés* upon glass or paper; the *positive* model comes *positive*; absolute preservation of the model; intact and immaculate; permanency; at least equal to that of engraving upon stone; and, lastly, the great economy of the process."

We have already mentioned the labours of M. Eugène Baroux, who, for several years past, has sought the means of perfecting the application of photography to engraving on wood. M. Baroux, an experienced engraver, is better qualified than most others to understand and overcome the difficulties which stood in the way of his predecessors. We have seen the results of the new experiments he has made, and we believe that the problem of photography on wood is definitely solved. The image is as complete as the best proofs upon paper, and a skilful engraver can engrave it as easily as a design drawn by hand, for everything is rigorously indicated except the cutting.

M. Moisson addressed to the Photographic Society a supplementary communication upon his process of vitrified photography. He says:—

"The locality of the exposition has made me see in my vitrified photographs a defect which previously I had taken for an excellence, that is, their transparency.

"When the glass plates have the sky for a background, they are good; but when they are exposed to trees for a background, their transparency is injurious to the subject and fatiguing to the eyes, which, as in Daguerreotype plates, are compelled to seek the picture.

"To avoid this defect, and to give to the pictures a vigour similar to paintings on glass, I submit them to a second baking, after having covered them with a flux (glass, to which a small quantity of calcined bones is added) on the same side as that on which the picture exists: this is very important, for the salt of silver of which the image is formed is developed with greater intensity under the action of the flux, and gives a semi-transparency to the picture, which no longer fatigues the eyes.

"It will be understood that the process I have described is applied only after having done everything indicated in my previous communication."

M. Blaizé presented to the Society a series of proofs, many of which were obtained by the tannin dry process; they were accompanied by the following note:—

"The method I adopt is that which I have found in the treatise by Major Russell. I have only suppressed many details, which appeared to me useless. I make use of my usual collodion and nitrate bath, and avoid special preparations; I suppress the gelatine, and I varnish the edges of the plate before developing. I found the success of plates much surer than with wet collodion; their only defect is in the length of exposure, which must be long to avoid too much *teasing* the negative under development; that, in fact, is the chief point in this method.

"Tannin plates appear to me good the end of a year, and I have developed old plates many months after they were exposed, which gave good results. This process is perfect for reproducing designs upon white grounds, on account of the vigour which may be easily obtained. I have, by this method, reproduced many designs by Gustave Doré, and I

obtained as much success, and, perhaps, more delicacy of detail than with moist collodion.

"Many amateurs have commenced with me the practice of this process, and all have found it excellent. For, in all our excursions, we have been able to take certain subjects that we could not by other methods."

M. Hulot made some remarks upon parchmentizing and splitting of paper, and he repeated in the presence of the Photographic Society an experiment, the results of which, known to some persons for several years past, have hitherto remained unpublished.

He takes a sheet of paper and immerses it in commercial sulphuric acid, diluted with about one-fourth its weight of water, and quite cold. The time of immersion is from twenty seconds to a minute or more, according to the nature and thickness of the paper. The sheet is next washed in abundance of water and partially dried between folds of bibulous paper, or in the air. By means of a penknife or the fingernails the paper is split open at one corner, first cutting into the margin an eighth of an inch with a pair of scissors. The separation being effected at the edge it may be continued with the greatest facility, whatever may be the dimensions of the sheet to be split.

M. Hulot remarked that other means exist of splitting paper which, although he would not submit a costly engraving to it, he employs to split in two paper printed on both sides.

This experiment is founded on a property of the material of which paper is made—cellulose—of being transformed, in presence of sulphuric acid, into dextrine or glucose. The commencement of the parchmentizing which results preserves the external portion of the paper from the action of the weak sulphuric acid, while the interior substance is submitted to its action and softened. Hence the facility of separating in two surfaces lightly parchmentized.

The president, M. Regnault, inquired if, by a peculiar method of drying, it was not possible to destroy the effects of contraction in the paper, and if it were not possible to split a sheet of paper of which the surface only has been parchmentized.

M. Hulot replied that he has split printed papers, and arranged the opposite sides on one page by gluing them upon a thin sheet of paper; dried, beaten, and inserted in a volume, by a binder, it kept in perfectly good condition. We can glue the paper to be split upon another sheet, or upon a glass plate, so as to expose only one side to the action of the acid; and it is by analogous means that we are enabled to separate several successive thicknesses of the same sheet of paper.

M. Nadar, the eminent photographer, appears to have solved the problem of aerial navigation, or, as he terms it, *Auto-locomotion-aerienne*. M. Nadar employs a screw propeller and inclined planes. He fully recognizes that his theory is not new, since, in 1768, fifteen years before the ascent of the first Montgolfier, Paucton, the engineer, predicted that the screw would be employed in aerial navigation. A society of French and English capitalists is in course of formation for the purpose of constructing a gigantic balloon, to carry eighty persons, in a car of two stories, and which will carry everything necessary for comfort and convenience, even to a printing press. The diameter of this balloon, the proportions of which have never been imagined even in the speculations of American newspapers, will be nearly three-fourths of the height of the towers of Notre Dame. The Lyons manufacturers have already supplied twelve thousand metres of white taffety for its construction, and it is expected that the monster balloon will be ready for the Baden races, next month. The first voyage will occupy eight days and nights, and most of the seats are already engaged.

It has been proposed to counteract the sulphurizing of positive proofs by treating them with chlorine.

The Photographic Exhibition in the Champs Elysées will continue open until the end of the present month, between the hours of 9:30 a.m., and 5:30 p.m.

A DIFFICULTY IN THE TANNIN PROCESS EXPLAINED.

SIR,—A short time ago you were so good as to give me some valuable hints on Major Russell's new process, and also to obtain from him more full details of the process, for which please accept my best thanks. I have since been experimenting with it, and, with the aid of the Major's new edition, have got some negatives which are very nearly perfect. I have still, however, one difficulty, which I shall presently describe, and which neither he, nor any work I have on the subject, mentions; it is this:—

On taking the plate out of the exciting bath, it is covered over with small projections, some not larger than a pin's point, others as large as the head. On close examination, these do not appear to be like a deposit, nor are they at all visible by transmitted light (until developed), but look as if there was a small bell of air or gas under the collodion film; these little projections entirely subside on drying the film; but, I suppose, from containing more tannin or other matters than the rest of the film, are less sensitive, and show, on developing, a clear, round spot, with a dark ring round it. Thinking it might arise from the collodion being too thick, I diluted it both with ether and equal parts ether and alcohol, but still the same spots. Then I thought it might arise from ether in the film forming vapour by the heat of the atmosphere, and allowed the film to get almost dry before immersing in the bath; still the same result, even apparently a little more. Then I thought perhaps the film should be immersed wet, and did so when the collodion ceased to drop. Then I tried whether a thicker coat of gelatine would help it, and made a 4-grain solution, having previously been working with 2½ grains, but still the same result; and now I do not know what to do, but have to-day made the bath alkaline, and put it in the sun, although it works well otherwise, and do not think it is impure, and, if so, cannot understand how any deposit could raise these little bubbles.

I may mention further that the projections are not so perceptible when the plate first leaves the bath as they are when in the distilled water, nor then so much as in the common water. This, I suppose, is because the fluid is more dense round them, and conceals them. I notice that an excited and washed plate, if taken into daylight, comes out in dark blue spots where these prominences are.

I have to go to the country in a few days, and have been anxious to get a few plates to expose, and should be exceedingly obliged if you could find room in this week's *Photographic News* for a hint on this subject.

I should mention exactly how I have been working

To the oz. of water, gelatine ... 2½ grains.

Collodion.

Pyroxyline 5 grains.

Bromide of cadmium 8 "

Alcohol, specific gravity about 830 ... 4 drachms

Ether 4 "

the collodion being mixed, one part made with a porous and rather structural collodion, the other two parts of a tough horny collodion, proportions in both cases as above; exciting bath 60 grains per ounce saturated with bromide of cadmium, first two washings distilled water, next hard water, and so on.

Begging you will kindly excuse my giving you so much trouble,—I am, dear sir, your obedient servant,

TYRO TANNIN.

Major Russell's explanation is as follows:—

DEAR SIR,—I shall be very glad to help your correspondent out of his difficulty if I can. I have never seen the fault which he complains of; but, from his description, I think it is caused by the gelatine swelling and penetrating the film of collodion, and perhaps leaving the glass. The following precautions will, I think, prevent the evil:—Dry

the plates well, either by heat or by standing separately for some time, after cleaning with old collodion to ensure adhesion of the gelatine to the glass; it may be known when they have been dried enough by the velvet rubber slipping easily over the plate; use very little acetic acid with the gelatine, and when this appears dry, finish the drying by heat to drive off all traces of the acid; this last precaution is particularly important in hot weather, to prevent solution of the gelatine during excitement. There appears to me to be too much water in the collodion; I should use either stronger alcohol or a larger proportion of ether. A rather larger proportion of the horny collodion, and perhaps a little less bromide, say seven grains to the ounce, would help to defend the gelatine. I have found bromized collodion to work well on a substratum of gelatine, but the film seems to be more permeable than when iodide is used, as the bromide of silver is formed more uniformly throughout the thickness of the film, and does not come to the surface like iodide during excitement; this circumstance is favourable in other respects, but renders a substratum of gelatine less applicable; I therefore prefer one of the following methods with this kind of collodion, especially for the alkaline developer; paint a very narrow strip of the surface near the edge of the glass very thinly with a solution of 2 to 5 grains of gelatine, in water, 7 drachms, alcohol, 1 drachm; for this purpose it is better to add nothing else. When the gelatine is dry the plate may be coated with collodion; or the edging of gelatine may be covered when dry by painting over in the same way with india-rubber and amber solution; or the whole glass, after being edged with gelatine, may be covered with the india-rubber and amber. This last is very easily done and answers well, if dust can be prevented from attaching itself to the india-rubber while drying. The india-rubber solution, if made with fairly pounded amber, should be allowed to stand and settle for some days, then, if decanted carefully, it will filter easily. Having been otherwise occupied, I have done nothing in the photographic way since April, until lately; and I found that the hot weather made some alterations in the way of working necessary. The bath required a considerable amount of acid; in cool weather a neutral one did well (the acid will act in the same direction as the high temperature in dissolving the gelatine), and the plates do not require to be kept so long in the bath; ten minutes I find enough for a highly bromized collodion in a 60-grain bath. The alkaline developer does not seem to work quite as well in hot as in cool weather, perhaps from want of sufficient acid in the bath. I forgot to say that if the glass is covered with gelatine solution, the liquid must be filtered immediately before pouring on each plate, as any clots would be likely to form transparent spots.—Yours very truly,

C. RUSSELL.

P.S.—I find the method which I have described in my new edition, of developing first with formic acid, and finishing with citric acid, to work remarkably well. Much acid is required in the developer in hot weather.

Romford, August 21, 1863.

Photographic Notes and Queries.

ROUGHING THE EDGES OF GLASS.

SIR,—Allow me to suggest to your readers the use of emery powder instead of silver sand as recommended by Major Russell in his excellent little book on the "Tannin Process," for grinding the margin of glass plates. It grinds much more effectually and evenly throughout, without chipping the corners of the glass.

I enclose a print, for your opinion, by tannin process.—I am, Sir, yours, truly,

THOS. R. LANE.

Sidney Place, Cork, Aug. 21, 1863.

[The print enclosed is very fine, indeed. Delicate, full of

detail, very brilliant, well-defined, and well-printed and toned. It only required a tint in the sky to make it perfect.—ED.]

SUCCESSFUL LIME TONING.

SIR,—The enclosed *cartes* are specimens of toning by Mr. Parkinson's lime process. I feel greatly surprised at reading accounts of failures from "Chameal-ion" and others. Nothing can be more simple, and no toning bath that I have used, or seen in my photographic career, gives such fine results as the lime one. A short time back I sent you a toning formula for Schering's paper. Although giving nice tones for albumen paper and working successfully, I have now thrown it aside. The reason I send you specimens is that you can quote me (if necessary) as one of the successful lime toners.—Yours respectfully,

DAVID DUNCAN.

Aug. 24, 1863.

GOLD TONING BATH WITH ACETATE OF SODA AND CHLORIDE OF LIME.

DEAR SIR,—I see Mr. Parkinson's letter in last week's paper mentions the use of acetate soda with chloride of lime and gold for toning. I have been using this bath, and believe it to be the very best I have ever tried. I keep my gold solution with a sediment of chalk in the bottle, and a saturated solution of chloride of lime in another bottle. To make my bath I put 1 grain of gold from the solution into 8 ounces water, and drop in 8 drops of the solution of chloride of lime. Then dissolve 40 grains, or 60 grains of acetate of soda, or potass, in it; put the solution in an open cup, and stand it in hot water about ten minutes; let it cool, and it is fit for use. Less chloride of lime might probably answer in place of heating it. It is certainly more manageable than either acetate soda alone, or chloride lime alone, and meanness seems banished. The enclosed prints were thus treated. I have lately built a glass studio after the plan of Mr. Matheson's somewhat, and find it answer admirably.—I am, Sir, yours faithfully,

WM. BARTHOLOMEW.

Egham, Aug. 24, 1863.

VARNISH FOR INDIA.

SIR,—I have just time before the mail leaves, to beg you to warn all Indian photographers against a hard spirit varnish made in England, apparently an imitation of Sohnee. I have just come down from the hills, where, as ill luck would have it, I ran out of varnish and bought a bottle. Every negative has become tacky, and some are useless.

A varnish for the tropics should stand an atmosphere at 90° saturated with steam for a week and then not be the least tacky. On the temperature rising in the sun (printing to 160° or 170°, negatives are often so hot that they blister one's hand. I believe lac (seed lac), in half spirits of wine and half alcohol, is a good varnish: it should be about 50 grains of seed lac to the ounce, and will then set when the plate is just warm. I have used this successfully and met no difficulties. I am now trying a formula given me by a professional, whose only fault is the great heat needed for setting it bright. I recommend all parties to get a good tried formula, and make their own varnish. It is cheapest, and I know none worth a straw in the market.—Yours obediently,

J. P. TENNANT, Major, R. E.

India, July 15, 1863.

Miscellaneous.

GUN COTTON.—Collodion is a viscid semi-transparent fluid, formed by dissolving pyroxyline (gun cotton) in a mixture of ether and alcohol. Pyroxyline is prepared by immersing cotton flax, unsized paper, or any substance composed of lignine in a mixture of nitric and sulphuric acid. In 1833 M. Braconnot discovered that, when starch was submitted to the action of nitric acid, it became converted into a peculiar substance, which dissolved in the acid, and was precipitated upon the addition of water. This substance, which was named, xyloidine, was found to explode when dry, at a temperature of 356°. The subsequent researches of M. Pelouze proved this substance to be starch, in which one equivalent of hydrogen was replaced by one of peroxide of nitrogen. In 1846 M. Schönbein discovered gun cotton

or pyroxyline, an explosive material, soluble in ether and alcohol. His method of making it was by immersing cotton in a mixture consisting of one part of nitric acid added to three of sulphuric acid. After being immersed for five minutes the cotton was washed repeatedly in water and dried. The sulphuric acid contained in the mixture was simply to absorb the water formed in the process, which would otherwise weaken the nitric acid and cause it to dissolve the pyroxyline. Chemists soon recognized the analogy of these two compounds, starch and lignine being similar in composition, and cotton fibre being nearly pure lignine. Further research proved that there were three principal varieties of pyroxyline, depending on the strength of the nitro-sulphuric acid used. By employing the strongest mixed acids the most explosive gun cotton was produced; it contained the largest amount of peroxide of nitrogen, and was only soluble in acetic ether. This was the quality most adapted for blasting operations. The second kind, made with a slightly weaker acid than the last, contained less peroxide of nitrogen, and was not so explosive, dissolved readily in ether and alcohol, and is now used for making collodion. The third form, made from still weaker acids, contained still less peroxide of nitrogen and was only combustible.

Talk in the Studio.

ROYAL PATRONAGE.—A few years ago, Charles Dickens specified having a photograph taken as one of the latter-day duties which should not be omitted. We are glad, for the sake of our art, to record that the reigning family of Great Britain are most exemplary and constant in their performance of that duty. Our readers who are familiar with the name of Mr. Jabez Hughes will be glad to learn that Her Royal Highness the Princess Louisa honoured him with another sitting at his studio a few days ago, when he succeeded in obtaining some excellent negatives.

FORGERY BY PHOTOGRAPHY.—Renaldi, the Swiss, who some time ago engaged a photographer named McGuire to forge, by photography, a one-gulden Austrian note, was recently found guilty. Mr. Sleight, in opening the prosecution, said:—The evidence would establish the fact that, for the first time in this country, the art and science of photography had been prostituted for purposes of fraud. It would be shown that a genuine note had been photographed on a piece of glass by a person named McGuire, under the direction of the prisoner, and that from that plate (had it not been covered with a coating to prevent its being so used), there might have been printed by a certain simple process thousands of notes, which would be more identical with the original note than any that could be produced by the tool of the engraver.

VALUE OF ARCHITECTURAL PHOTOGRAPHS.—In a report from the Council of the Architectural Museum, South Kensington, on the formation of a National Museum of Architecture, they remark, "It is impossible for an architectural museum to have too many photographs. Cheap and comprehensive as they are, they are always worth collecting, and any fastidiousness as to their acquisition would be misplaced. * * * There is hardly a new building now undertaken which is not photographed at the instance of the architect, or the employer, and an understanding might easily be established that it was expected that a photograph of every new construction, possessed of any architectural character, should be deposited in the National collection."

To Correspondents.

JAMES STODDARD.—We are not aware whether Mr. Pouncey has appointed any agent for the sale of his prepared paper; but it can be obtained direct from himself. A note addressed to him, at Dorchester, will find him. We do not know whether he will supply sample sheets.

LIME.—We do not know of any method you could adopt to secure an engagement in France, except by advertising. Possibly an advertisement in the *Moniteur de la Photographie* might aid you. The address of the publisher is M. Lieber, Rue de Seine, Paris. Mr. Parkinson recently needed assistance, but is supplied.

TYPO.—It is recommended that printing, toning, and fixing should be completed within twenty-four hours of exciting the paper, because, independent of the action of light, a slow decomposition goes forward when nitrate of silver and organic matter, such as albumen, are brought into contact or combination, which gradually deteriorates the colour of the paper. Under some circumstances, the excited or printed paper may be kept longer with impunity, but not usually. If you try to keep the prints a week before toning and fixing you will see the result. 2. If your new bath does not

work well it may proceed from two or three causes. It may arise from a slight amount of alkalinity, in which case the addition of a drop or two of nitric acid will remedy the evil. It may arise from impurities in the silver or distilled water, in which case, first add a little of a solution of carbonate of soda, sufficient to leave the bath turbid, and then expose it for a few hours to a bright sunlight, which will reduce any organic matter present. Then filter and try a plate. It will, probably, work well. If not quite clear in the shadows add a trace of nitric acid. 3. You cannot readily eliminate acetic acid from a nitrate bath. By boiling down the bath to dryness you may get rid of a great portion of it. By adding carbonate of soda you will form acetate of silver, and by reducing the temperature as low as possible a portion of this will be precipitated, and may be filtered out. Or, by sunning, a portion will be reduced, and may be filtered out. 4. Your prints assuming a feeble sandy colour in the printing frame, instead of a rich brown or purple, suggests that a silver bath is getting weak. Add more silver to it. M. A.—You will find an interesting article on printing in skies by Mr. Noverre in our number for April 10th of the present year. Also in Nos. 115 and 156, by Mr. Samuel Fry, and in 157, by Mr. Maxwell Lyte. The subject has been incidentally treated in other articles, but these will probably serve your purpose.

AMENIA ASKS.—Would any of your readers give me the address of the following firm in Germany:—Anstalt v. Otilie Wigand.

A RECENT SUBSCRIBER.—Col. Stuart Wortley gave full details of his operations in producing his fine instantaneous pictures at a meeting of the Photographic Society this year. You will find his paper in the *Photographic News*, Feb. 13, 1863. We agree in your remarks on the importance of clouds; the subject has been repeatedly treated in our columns, and will probably be again shortly.

R. RODGERS.—By careful working you may secure an angle of about 40° with a single landscape lens; but not much beyond that, especially in architectural work, which readily shows the distortion. 2. Distilled water purified with permanganate of potash may be used for photographic purposes. There should not be excess of permanganate, so soon as the water shows the faintest trace of permanent colour it has had sufficient. 3. The effect of all varnishes is to add slightly to the transparency of negatives, and thus slightly reduce the intensity. A very dilute varnish which will glaze the shadows and let the lights dry dead, will do this in the least possible degree. 4. We cannot tell you how to obtain good specimens of card pictures except by selecting from those which are published for sale.

AN AMATEUR SUBSCRIBER.—Your negative is a little under-exposed and over-developed, or over-intensified. With a better negative, deeper printing, and longer toning you would get the colour you desire, with the same toning bath.

T. SANDENS.—M. Disderi does not, so far as we know, use the lime and gold toning bath.

W. H. B.—The tone of the print is very good, but it is not desirable to need such a prolonged immersion to obtain it. 2. The printing is good, but the negative is faulty, being over-intensified, and the figure very stiffly posed. 3. There are generally engagements open to good photographers, the remuneration varying very much, just as the degrees of ability vary. 4. We are glad to learn that your lens is a good one. The definition of the print is very satisfactory. We shall be glad to see specimens of your progress.

ARCHITECTURAL STEREOGRAPHS.—We are requested by Messrs. Dutton to state that the stereographs of churches in Bristol and Bath, noticed in our last, were produced with Ross's single stereo lens of 4½ inch focus. The definition is excellent, but the curvature of marginal lines, inseparable from the single lens, is in some instances very apparent. The use of a double combination is preferable for interiors and all architectural work.

AL FRESCO.—So far as the open air lighting is concerned your pictures are not bad; the posing is also pretty good. A little longer exposure would have been an improvement and a little lighter printing. The toning effected in your lime bath is most satisfactory.

F. N.—The objection to the use of iodide of iron consists in the fact that the collodion does not keep well when prepared with it, and is apt to injure the bath. Its use certainly gives rapidly, and it is possible that further experiments would repay the student.

J. M. PRICE.—We are glad to learn that you have found your globe lens so satisfactory, and should have been glad to have had a more detailed statement of your experiments. You mistake altogether in supposing that we have any wish to disparage the lens in question. We readily admit the good points it possesses—such as embracing a wider angle than the single lens, being free from distortion, and giving great depth of focus; but it does not include the angle claimed for it, namely, 90°; and its depth of focus is the result of spherical aberration, and there is a consequent loss of crisp definition. In our estimation, so far as we have examined the lens, or seen its work, it is not equal to the triple for general use. The Americans compare it with the old lenses, but ignore the triple altogether.

Several articles in type, amongst which is one on the new method of "Transferring the Film from the Albumenized Paper to Porcelain," &c., stand over until our next.

Several Correspondents in our next.

Photographs Registered during the Past Week.

MR. JOHN NICOL, 2, Bath Street, Nalra, N.B.,
Three Photographs of Captain Jas. A. Grant, Discoverer of the Source of the Nile.

Photograph of Captain Jas. A. Grant, and Colonel Rigby.

MR. AUSTIN H. CLARKE, Ripon,
Two Photographs of Lord and Lady de Grey.

MR. JOHN BEATTIE, Clifton,
Four Photographs of the Rev. — Craik.

MR. JOHN STEPHENS, 92, High Street, Whitechapel,
Photograph of Dr. Coffin.

MESSRS. SHORE AND CO., 11, Western Road, Brighton,
Photograph of Mr. William Shore.

MESSRS. MINSHULL AND HUGHES, Eastgate Row, Chester,
Two Photographic Groups of Sir S. R. Glynne, Bart., Mrs. W. E. Gladstone and Family.

Two Photographs of Lieut.-Col. Sir Charles Shakerley, Bart.

THE PHOTOGRAPHIC NEWS.

Vol. VII. No. 261.—September 4, 1863.

CONTENTS.

	PAGE
Transferring the Image from Albumenized Paper to Porcelain, &c.	421
British Association for the Advancement of Science	422
On the Production and Use of Cloud Negatives. By V. Blanchard	424
Photography in Australia. By Paul Ricochet	425
Tannin Negatives for Enlargement. By M. Julhiet	426
Photolithography. By P. Leisegang	427
Yellow Varnish for the Windows of an Operating Room	427
On a New Kind of Miniature, &c. By Henry Swan	428
Eden's Microscopic Camera.....	428

	PAGE
Process for Printing Positives without the Salts of Gold and Silver. By M. De Motieff	429
Correspondence—Foreign Science—Photography in Cape Town —Photographs in Printing Ink	429
Photographic Notes and Queries—Liquid Colours for Photographs—Photographic Discoveries	431
Talk in the Studio	432
To Correspondents.....	432
Photographs Registered during the past Week.....	432

TRANSFERRING THE IMAGE FROM ALBUMENIZED PAPER TO PORCELAIN, ETC.

WE have just successfully completed some experiments with a new process for the application of photography to ornamental art, which promises very pleasing results, and will interest many of our readers. It consists in transferring the film of albumen on which is impressed the photographic image from a negative on to a vase, jar, or other surface of porcelain, enamelled glass, &c., in which position it is seen either as a direct positive or a transparency. The process originated in the establishment of M. Beyrich, of Berlin, and is due, we believe, to M. Grüne, a chemist in his establishment. Our attention was first called to the subject by Mr. J. W. Osborne, who is at present residing at Berlin. In a letter received a couple of months ago, he says:—

I have visited Beyrich's factory, and have been received in a very friendly manner. Mr. Grüne, the chemist there, is at present engaged in perfecting a new description of positive paper, by which photography can be transferred to any surface curved or flat, and of metal, wood, glass or porcelain, indiscriminately. This paper is so constituted, that after the printing and toning has been effected upon it by the ordinary methods, the whole film of albumen is made to detach itself from the paper, and to swim freely in a large quantity of water. The article to receive the photograph, is now brought under the film and lifted from the water with the picture in the desired position upon it, or nearly so, for it admits of perfect adjustment with the fingers. When dry, the film adheres with great tenacity to any smooth surface, and after a coat of varnish has been applied, it is in a condition to resist a moderate amount of washing and rubbing. I shall have more to tell you about this matter and many others, which have come under my notice here. For the present, I must defer sending you the paper, but am able through the kindness of Mr. Grüne of the firm above named, to forward you by an Australian friend who leaves Berlin for London this week, two or three specimens which will serve to illustrate what has been accomplished. As far as I can judge, the whole of the operations are perfectly simple, and I believe the process will be found a useful one for ornamenting many articles of luxury or comfort.

The examples referred to never arrived; but we saw one or two specimens of ornamented vases sent by M. Beyrich to the French Exhibition, which were very beautiful. A few days ago, the Hon. Nassau Jocelyn, secretary to the British embassy at Berlin, an able and enthusiastic photographer, and esteemed correspondent of THE PHOTOGRAPHIC NEWS, sent us two charming pictures transferred in this way on to opal glass, and placed in ornamental frames, with supports, to allow them to stand in a position which permits them to be examined either by transmitted or reflected light, as ordinary positives or as transparencies. They are beautiful as ordinary positives, but still more so as transparencies. Being printed on albumenized paper, and toned in the ordinary manner, the tone and general character of the image may vary from the effect of a sepia drawing to that of an engraving. The most pleasing tint is a warm sepia or delicate purple; these before us have the former tone.

The instructions we have received from Mr. Jocelyn are as follows:—

The paper (resembling ordinary albumenized) is silvered as usual, but *very* much over-printed from the negative, in fact, till the lights are quite gone, and the print appears lost. It is then washed to free from silver, and toned, and then rinsed.

While rinsing, the print may be observed to be covered with blisters. These gradually increase in size until finally the delicate film of gelatine upon which the picture is, splits off and floats into the water.

It is then very carefully placed in hypo, and then well washed—every washing appearing to render it more tough, till at last it may be handled with impunity.

The glass, or porcelain upon which it is to be placed is then passed under the film, and both lifted out of the water together. When dry, it is trimmed, and covered with transparent hard varnish.

We have also received from Messrs Harvey, Reynolds, and Fowler a sample of paper for producing these pictures, prepared, we presume, by M. Beyrich. As the instructions they forward vary slightly from those just given, and contain one or two additional hints, we repeat them also.

Excite the paper as for albumenized paper. Dry. Print *very* deeply, you can scarcely print too deep. Tone as albumenized paper, more care will be required as the prints are over-printed, and the changes of tone are not so readily observed. Wash in water. A film now begins to leave the paper. Pass into the hypobath one part in five. The film now entirely separates from the paper, and the paper must be removed. Let the film remain in the hypo about ten minutes, and then carefully and thoroughly wash in water. The film is now very elastic.

To transfer this film on to any surface: *well* clean the surface, and bring it under the film which is floating on pure water. Raise both out of the water together, pull the film into the desired position on the object, and let it dry. Then varnish with a clear varnish. If the film should not adhere as closely as desired on round surfaces, wash it (without removing it from the object) with a mixture of 1 part acetic acid 32°, and 6 of water. As soon as it becomes elastic, wash with water, and it will adhere well.

As the manipulations thus described seem to present some difficulties we were anxious, prior to bringing the process before our readers, to put it into practice. We have accordingly exposed half a dozen pictures and transferred them according to instructions. We have succeeded beyond our expectations, and have obtained, at the first attempt, some very pleasing transfers. We will briefly detail our proceedings.

The paper was excited on a sixty-grain bath, and a couple of pieces exposed under a portrait negative, until the highest lights were of a lavender tint. This we subsequently found was not quite deep enough. The prints were washed and toned as usual, reaching a deep purple in the gold bath, which was one made after Parkinson's formula. On being transferred to a dish of water, and washed well, we did not observe either blistering or entire separation of the film as

expected. We then transferred them to the hypo bath, and allowed them to remain a quarter of an hour. A slight blistering was now apparent, which increased in the subsequent wash of water. But as the separation did not take place so speedily as we anticipated, we added a trace of carbonate of soda to the water, and in a few minutes we saw the delicate transparent film separated from the paper, and floating in the water. After rinsing we placed a piece of white enamel glass underneath the floating film, and by a little careful management, lifted it from the water, uninjured and stretched flat upon the glass, where it dried, smooth, bright, and firm. We now exposed a couple more, and printed until the image was completely buried, after which, before toning, we trimmed the print to the shape we desired, as we found it was a difficult thing to shape the film when once detached from the paper. We toned this time in a bath containing a little carbonate of soda, and we observed in the subsequent rinsing, that the blisters began to arise; these increased in the hypo bath, and in the course of the subsequent washings, the film readily separated and floated away from the paper. A subsequent couple were toned in the lime bath, washed, and fixed. These also separated in the subsequent washing without any trouble; but a longer time was necessary, some hours elapsing before the film of albumen was quite detached.

Some care and skill in manipulation are necessary in getting the film in proper shape, and into the proper position on its final resting place. The attenuated film, as delicate as the wing of the smallest fly, at first sight seems quite unmanageable, curling, twisting, and folding itself with the slightest disturbance of the water, and if the object on which it is to be placed be brought under it, and both lifted out of the water without proper precaution, it will probably be found to have run up together into a shapeless mass, apparently beyond remedy. If it be carefully returned to the water, the probability is that it will gradually float straight out again, and present itself quite uninjured. A little care and patience will be required. Our second attempt was to transfer the film, which had previously been cut when on the paper, into a medallion, on to a cylindrical vase; and using a little care and tact, we succeeded perfectly. The film was placed in a large basin of water; the vase was introduced under it, and brought carefully into the right position. It was then lifted carefully, so as to avoid making a wave in the water, which would have sent the film floating away, turning somersaults in the most tantalizing manner. The film, although so slight, is very tough, and admits of a little careful readjustment; but is very easily stretched out of shape, and should be as little handled as possible. After it is fixed in its place and dry, it may be trimmed, if necessary; but it is better to cut the print to the desired shape when it leaves the pressure frame.

The variety of ornamental purposes for such transfers will readily suggest themselves. When transferred to plain white enamel glass, the pictures acquire not only a beauty as transparencies, but also as positives, which they did not possess before. The pure white and fine surface seems to impart a wondrous charm of delicacy and brilliancy altogether unexpected, which, for locket and brooch portraits, will possess especial value. It is probable that the film so transferred to ivory will be of value to the miniature painter. As ornaments for vases of opal glass, &c., many very beautiful effects may be produced. In the art of diaphanie, and as an adjunct to the now fashionable art of decalcomanie, it will probably be found useful; and in a variety of ways which do not now occur to us. At present, the only protection is a hard varnish, but it is possible that by the use of an enamel powder fusing at a low temperature, a vitreous surface might be secured.

One or two cautions, arising out of our experiments, we may suggest. If the film be transferred to plain glass flashed with a white enamel, take care that it is to the flashed side that the film is attached, otherwise, as will be readily seen a very imperfect result is produced. Avoid the

use of a ground or unpolished surface, as the film is apt to crack on drying when attached to such a surface. A little carbonate of soda will aid the separation of the film from the paper, but it is better to have patience, and let it be effected by time. The film appears to rest on some coating applied to the paper, and which is soluble in water, and may be seen to diffuse itself therein. It is but a question of time, therefore, to secure entire solution.

The process affords singular facility for observing certain facts in regard to the nature of the image on albumenized paper. It is to be noted that when the film of albumen is removed, a perfectly defined image is found on the paper underneath. It is also to be noted, as confirming the conclusions of Mr. Spiller, and contradicting those of Dr. Schnauss, that whilst the colour of the image on both sides of the film may be the rich purple of gold, the image underneath, on the paper, is of the foxy red of an untuned silver print.

British Association for the Advancement of Science.

THE meetings of the British Association just concluded at Newcastle on Tyne have been, in some points, perhaps, the most successful which have ever been held. The number of members and of associates enrolled, and the funds collected have, we believe, exceeded those of any former occasion. The works of art collected in the Exhibition, got up in connexion with the Association, were unusually fine and interesting. The excursions to the scenes of various important industries were numerous and inviting. Many of the subjects brought forward were interesting and ably treated. The inhabitants of the town and district were enthusiastic and hospitable. But with all this, we cannot rid ourselves of the impression that there was a great deal of mismanagement in various respects. However little the inhabitants generally are answerable for the fact, it does not tend to enhance the reputation of the town, that the hotel keepers should seize the occasion when the town is honoured with an especial influx of scientific visitors, to fleece their guests: in some instances, we believe, increasing their regular tariff two hundred per cent. It does not tend to improve the reputation of the Association, that, after a paper has been examined and accepted by the committee of a section, the chairman should brusquely tell the reader when he has just commenced to read, that his paper was of a nature which cannot be received. It is, however, easy to find fault, and we are, perhaps, the more ready to be imperfectly satisfied, from the fact that no former meeting for some time was so barren of photographic interest as the present. There was no properly photographic paper of any kind read, and not many at all connected with photography. Our art-science, in fact, has scarcely a home in the Association. It vibrates uncertainly between section A, Mathematical and Physical science, and section B, Chemical science. We look forward to the day when a section shall be devoted to photography and its various branches; and when greater temptations and facilities for bringing it forward shall be the inducement to many gentleman to bring forward matters of interest, which are at present undisputed at the Association.

The meetings commenced on Wednesday, the 26th ult. The address of the President, Sir William Armstrong, was marked by strong practical common sense, and was of a popular rather than of a recondite or elaborate character. No recognition was made in it of photography as one of the great discoveries or wondrously progressing powers of the day, although an art less popular, if not less important—photography—received more than a passing notice. Much, however, of the able speech of the President dealt with the agencies, every detail in connection with which is interesting to photographers. The startling fact, that the sun is the

great source of power and motion on the earth was admirably pointed out, especially in its relation to the production of coal. "That small pencil of solar radiation," he remarked, "which is arrested by our planet, and which constitutes less than the 2,000-millionth part of the total energy sent forth from the sun, must be regarded as the power which enables the plants of the carboniferous period to wrest the carbon they required from the oxygen with which it was combined, and eventually to deposit it as the solid material of coal. In our day, the reunion of that carbon with oxygen restores the energy expended in the former process, and thus we are enabled to utilize the power originally derived from the luminous centre of our planetary system." His further glance at the nature of the sun is worthy of quoting:—

"In the course of the preceding observations I have had occasion to speak of the sun as the great source of motive power on our earth, and I must not omit to refer to recent discoveries connected with that most glorious body. Of all the results which science has produced within the last few years, none has been more unexpected than that by which we are enabled to test the materials of which the sun is made, and prove their identity, in part at least, with those of our planet. The spectrum experiments of Bunsen and Kirchhoff have not only shown all this, but they have also corroborated previous conjectures as to the luminous envelope of the sun. I have still to advert to Mr. Nasmyth's remarkable discovery, that the bright surface of the sun is composed of an aggregation of apparently solid forms, shaped like willow-leaves, or some well-known forms of Diatomacea, and interlacing one another in every direction. The forms are so regular in size and shape as to have led to a suggestion from one of our profoundest philosophers of their being organisms, possibly even partaking of the nature of life, but, at all events, closely connected with the heating and vivifying influences of the sun. These mysterious objects, which, since Mr. Nasmyth discovered them, have been seen by other observers as well, are computed to be each not less than 1,000 miles in length and about 100 miles in breadth. The enormous chasm in the sun's photosphere, to which we apply the diminutive term 'spots,' exhibit the extremities of these leaf-like bodies pointing inwards, and fringing the sides of the cavern far down into the abyss. Sometimes they form a sort of rope or bridge across the chasm, and appear to adhere to one another by lateral attraction. I can imagine nothing more deserving of the scrutiny of observers than these extraordinary forms. The sympathy also which appears to exist between forces operating in the sun and magnetic forces belonging to the earth merits a continuance of that close attention which it has already received from the British Association, and of labours such as General Sabine has with so much ability and effect devoted to the elucidation of the subject. I may here notice that most remarkable phenomenon which was seen by independent observers at two different places on the 1st of September, 1859. A sudden outburst of light, far exceeding the brightness of the sun's surface, was seen to take place, and sweep like a drifting cloud over a portion of the solar face. This was attended with magnetic disturbances of unusual intensity and with exhibitions of aurora of extraordinary brilliancy. The identical instant at which the effusion of light was observed was recorded by an abrupt and strongly marked deflection in the self-registering instruments at Kew. The phenomenon as seen was probably only part of what actually took place, for the magnetic storm in the midst of which it occurred commenced before and continued after the event. If conjecture be allowable in such a case, we may suppose that this remarkable event had some connection with the means by which the sun's heat is renovated. It is a reasonable supposition that the sun was at that time in the act of receiving a more than usual accession of new energy; and the theory which assigns the maintenance of its power to cosmical matter plunging into it with that prodigious velocity which gravitation would impress upon it as it approached to actual contact with the

solar orb, would afford an explanation of this sudden exhibition of intensified light in harmony with the knowledge we have now attained that arrested motion is represented by equivalent heat."

Our space does not permit us now to give all the sectional papers which may interest our readers; but we hope to do so in our next. In the meantime we may glance at what was done at all interesting to photographers. On Wednesday the Report of the Kew Committee was read; it presented many interesting illustrations of the aid photography is lending to the sciences of astronomy, magnetism, &c. On Thursday Mr. Claudet read an interesting paper on "Some Phenomena produced by the Refractive Power of the Eye." On Friday the same gentleman read a paper on "The Star Chromascope;" Mr. B. S. Proctor read a paper on "The Focal Adjustment of the Eye;" and the Abbé Moigno exhibited and described an instrument invented by M. Soleil, called the Tenebroscope, for showing that light itself is invisible. On the same day, in the Chemical Section, a very interesting report on gun-cotton was read, describing and illustrating by experiment its superiority in many respects over gunpowder. On Saturday, in Section A, Professor C. Piazzi Smyth exhibited some of his photographs taken on Teneriffe, at an altitude of 10,700 feet, of a landscape four miles and a half distant, and pointed out the perfect and clear rendering of detail as an illustration of the more perfect actinic conditions at a high elevation. One of the specimens exhibited was a photographic engraving, the latest result of Mr. Fox Talbot's experiments in photoglyphy, a decided advance upon former attempts.

On Monday, in the same section, Mr. Stewart read a paper on comparisons of curves afforded by the photographic self-recording magnetographs, at Kew and Lisbon. In the same section, on Tuesday, Mr. Swan read a paper, "A new kind of Miniature, possessing apparent Solidity, produced by means of a Combination of Prisms." Mr. Swan's paper, which appears in another page, describes a most ingenious application of the stereoscopic principle. Two triangular prisms are placed in such a position as to form one cubical prism. Two transparent positives, taken at the proper stereoscopic angle, are mounted in such a manner that one is seen directly through the cube, and the other by reflection from the face of the prism, the two images being thus superposed and giving perfect relief. The specimens exhibited were neatly mounted in morocco cases, and in gold, to be worn as charms, &c. They are backed by opal glass, and some of them coloured. The result is as pleasing as the contrivance is novel and ingenious.

In section B, a paper by Mr. Dallas was announced, on Photo-electric Engraving and Observations on Photographic Engraving. As the whole details of the process were not to be given, the chairman thought the paper inadmissible. We shall, however, print it in full, or in abstract. The Abbé Moigno exhibited some fine photolithographs, by M. Marquier, and made a few observations on the method. He also exhibited some micro-photographic specimens mounted in rings, &c. Dr. Phipson read a paper on a new method of measuring the chemical action of the sun's rays. These complete the papers which had any photographic interest or bearing.

Photographs were frequently used to illustrate papers in the various sections, and at Mr. Glaisher's lecture on ballooning some very clever photographs were exhibited, produced by Messrs. Negretti and Zambra, showing Mr. Glaisher with his instruments arranged, together with Mr. Coxwell in the ear of the balloon, which appears to be just entering into the clouds, and leaving the earth dark and indistinct beneath. The picture is produced by the combined aid of photography and art. The ear and its occupants were photographed whilst the balloon was held to its moorings, and the background and other effects painted in with very clever effect.

The soirees, lectures, balls, &c., were unusually attractive and crowded. In the Central Exchange News-room a very fine collection of works of art and science was exhibited.

Amongst these were comprised a splendid collection of oil paintings and water colour drawings by great artists, contributed by various gentlemen in the neighbourhood. Fine specimens of the natural products and industrial arts of the district. Curiosities natural and artificial. Rare ores and metals, amongst these being an ingot of thallium, by Mr. Crookes, weighing a quarter of a hundred weight. Various beautiful specimens of aluminium bronze, amongst these being a specimen of M. Willeme's photo-sculpture, in the shape of a full-length statuette of M. Emile Percire. Microscopes and objects by Ross and others. With the exception of some solar camera enlargements by M. Claudet, and some enlarged copies of the moon, by De la Rue, we did not observe any photographs exhibited. This omission was partly due to want of space and partly to the difficulty experienced on such occasions to draw the line satisfactorily between what is interesting to the public and what is simply sent for advertising purposes. Altogether the Exhibition was a most interesting one, possessing more valuable contributions than generally find their way into local exhibitions.

ON THE PRODUCTION AND USE OF CLOUD NEGATIVES.

BY V. BLANCHARD.

THE great stride made by landscape photography during the past few years is now fully admitted. Those, even, who were most doubtful that photography would ever make or maintain a position among the fine arts would scarcely deny that the landscape productions of to-day show an undoubted advance upon the black and white patches produced a few years ago and called by courtesy *photographs*.

But with this marked improvement of the last few years has risen also the standard of criticism. We get now something like atmosphere into our best landscapes, but they will be *perfect* only when produced instantaneously, so as to secure *all* the effects visible to the eye of the camera at the moment when the picture is taken. Pending the arrival of this "good time coming," when it will be possible to produce landscapes of any size instantaneously, no matter how trying the subject, we must be content to do the best with the means at hand; and as white paper, in place of atmosphere, is now an abomination, the only plan left is to print the blank surface with something that shall bear resemblance to nature, sufficient at least to make it passable.

The printing in of clouds from separate negatives is not without some difficulty, but with ordinary care results can be produced sufficiently true to nature to be pleasing to the general eye. The best effect, of course, can only be produced by taking the cloud negative just immediately before or after the landscape one. But here comes the great difficulty. The days most suitable for the landscape photographer, who perchance is working with dry plates and is compelled therefore to give one, five, or ten minutes, are those when Boreas and Sons have taken holiday and have gone to the sea side for a change, and when, in consequence, all nature assumes an air of listlessness; the trees even are too idle to shake their thin leaves or sway their heads. These days so earnestly looked for by the landscape photographer, so few and far between—for even the elements believe in work in England—are just the days when the clouds are absent with a ticket of leave, to join company with Boreas and family, they being inseparable companions. The photographer is compelled, in spite of himself, if he desire to fill up the nakedness of his sky, to print from some negative foreign to the scene, and whilst the result so obtained will be pleasing to many it will never quite satisfy the eye of the close observer of nature. It can easily be said that the picture will be quite as true as the great mass of landscape paintings, which are invariably the results of a number of separate studies. This will, however, be but a poor apology, for when we examine the works of Turner or Stanfield and then turn to our best instantaneous productions, we see there caught at

once; many of those atmospheric effects, which cost them a lifetime of patient study, with all the appliances of colour to aid them in their efforts, and then only imperfectly rendered. An examination of almost any instantaneous picture will at once show that there are a thousand little points of detail that only such men as Turner, and a very few others, have been able to indicate. The long trail of smoke from some steamboat, like an immense dusky snake slowly unwinding his gigantic coils over the scene, but with the shadow also blotting out the sunlight wherever it falls. The sea mist coming up veiling one portion of the picture in gloom and indistinctness, while the other part stands with preternatural sharpness, that every little cloud scudding rapidly across the sky is faithfully represented in the scene below by its corresponding shadow; all these, and a thousand other effects, are caught in the instantaneous picture, and cannot possibly be rendered where the exposure is long, and where the clouds are printed in separately. It will at once, then, be apparent that great judgment is needed in using cloud negatives, and that they cannot be used indiscriminately without producing pictures open to very serious criticism.

The most beautiful studies of clouds are produced when the camera is pointed towards the sun, for greater contrasts of light and shade are seen. Cloud negatives so taken, however, can, unfortunately, seldom be used, for in landscape photography the operator is not often so daring as to work with the light in front, and of course such negatives can be used only when the landscape is thus lighted. Care must also be taken to choose an open space with no objects to break the horizon line. The sea side is best for this purpose. The grand banks of cumulus clouds are best to photograph, and are most effective, but care must be taken not to get them too large, otherwise the want of corresponding shade in the landscape will be painfully felt. Some of the very best clouds are to be seen when the sun is obscured, for they are generally of various shades of grey, and in consequence are more manageable; but care must be taken to print them in very light, or it will be seen at once that there is no sunshine on them. Contrary to what might have been expected, no great care or extra preparation is needed to procure clouds; any bath in good working condition will do. The stop in the lens should be moderately small, and a landscape lens will be found better as a rule than a double combination. The time should be as nearly as possible the same as that chosen for the negative, for nothing could be worse than to use clouds taken in the evening, when the sun is low, for a picture taken at 12 at noon. The exposure for cloud negatives will vary slightly with the amount of light, but, as a rule, the focussing cloth taken off the lens and back again as rapidly as the hands can execute the operation will prove about the necessary amount of exposure.

Some considerable degree of judgment will be needed to know the clouds best suited for the purpose, and a number of failures may be expected. There are many clouds most agreeable to the eye that will show no relief when taken, and much disappointment will be avoided by studying form rather than colour. The collodion best suited for the production of clouds is one favourable to intensity to begin with, and should be of a deep sherry colour, and if not so to begin with, may be made so by the addition of a few drops of tincture of iodine. The developing solution should be about 15 grains to the ounce, and should contain rather more than the usual quantity of acetic acid, say 20 drops to the ounce, for it is necessary to have the shadows as transparent as possible. The negative will not need to be dense, therefore, very little, if any, intensifying will be needed. A little pyro, with a few drops of silver added, poured on and off a few times, will be sufficient. If the surface is just darkened, it will be found sufficient.

In printing from the negative it will be found best to print the clouds first, care being taken to cover up with cotton, wool, and paper, as nearly as possible, all the parts

required for the landscape. If a few trees, or any dark object rise up into the sky, no notice need be taken of them, for the slight staining of the paper from the cloud negative will be completely lost in the after printing from the negative.

It will be found a capital plan to put a piece of cardboard, slightly curled upward, outside the pressure frame containing the cloud negative, taking care that all the parts required for the landscape are covered. If this be printed in the shade, and the curled edge of the cardboard be towards the sky, the light will subdue itself under the curled edge, and will so produce that softening towards the horizon so necessary to make a success of this method of double printing.

By means of an enlarging camera, it would be possible to make negatives from stereoscopic ones that would serve for all kinds of pictures. An enlarged transparency would have to be made, and then from it the negative could be produced of any dimensions necessary to suit the requirements of the picture.

For those who have no cloud negatives, nor the time to watch for the suitable opportunity to produce them, there is a very simple plan for getting rid of the white paper sky, and materially improving the appearance of the picture. It is, indeed, so simple that an apology is almost needed for mentioning it in these pages; but there may be some who have never heard of it, and to whom the idea may never have occurred, therefore it shall be described. After the print is taken from the pressure frame, lay it on a large book, and take a piece of cardboard larger than the picture, and move it slowly up and down, taking care that the picture positive is always covered. Of course, this operation must be performed in a good light. It may be done in sunlight, but greater care is needed. The sky will be found, on examination, to have darkened down towards the horizon in an uniform manner, giving the picture very much the appearance of an Italian sky. Care must be taken, however, not to overdo it, or the sky will look heavy and muddy. Indeed, just the reverse of the desired effect will be produced.

We regard the plans here suggested as imperfect remedies for the cure of that great eyesore, a blank paper sky, and to be used only for want of something better, but fervently trust that the day is not far distant when the optical and chemical aids to photography will be so far perfected that instantaneous pictures will be quite easy on dry plates of any size.

PHOTOGRAPHY IN AUSTRALIA.

BY PAUL RICOCHET.*

WHILE in Hobarton, I had heard a great deal about the beauty of the scenery round Lake St. Clair; and the descriptions I had listened to, induced me to make up my mind to go there.

Now, in the old country, when a man makes up his mind to go any whither, he has merely to pack his bag, consult his Bradshaw, order a cab and take his ticket; but here, in Tasmania, the case is very different.

I discovered that for my expedition to Lake St. Clair, many things were needful, inasmuch as the latter part of the journey being through an almost uninhabited district, would necessitate camping out at night, and a proper supply of provisions.

Fortunately, a friend, who had been there before, declared he would accompany me, and with his assistance, and that of my servant, Mr. O'Corcoran (who knew no more what to do than myself) all requisites, including a horse and light, but stroug, spring cart to carry everything, were at length collected, and we took our departure, amid the sympathizing adieux of many friends.

The first twenty miles of our road lay beside the left bank of the Derwent, which, appearing and disappearing among

the hills, formed as it were a series of lakes. It was too late in the afternoon to photograph these "morceaux" satisfactorily, and we hastened on to New Norfolk, a township twenty miles up the river, which we reached at 10 o'clock in the evening.

Here we supped sumptuously on fresh-caught mullet, and the next morning started again on our pilgrimage—my friend Stedley and myself marching behind the cart, which O'Corcoran sitting in, drove solemnly, at the rate of three miles an hour.

In this way we traversed some eight or ten miles of a picturesque country, and arrived at the township of Hamilton, on the Clyde, about mid-day. After a halt of two hours, during which I photographed some falls at the junction of the Clyde and Derwent, we resumed our journey, reaching the village of the Ouse at nightfall. The next morning I got a fine view of the bridge over the rock-broken torrent which gives its name to the village.

Leaving the Ouse about 11 a.m., a steady walk of some twenty-two miles brought us to the foot of the Victoria Tier. In former days of the colony, there was a small settlement on the ridge of these hills, but it is now abandoned, and here, in consequence, we had our first night's camping out.

A grassy glade, near a water-hole, surrounded by thick tea-tree "scrub," was chosen as the spot to build on, and, having tethered our horse within reach of the water, we manufactured a tent of blankets stretched on green poles, and floored with tea-tree boughs, on which were laid our opossum-skin rugs.

A blazing fire was soon sputtering in front of the tent, and our kettle sang cheerfully as Mr. O'Corcoran prepared the supper, in which we all joined with keen appetites. Supper over, each man rolled himself in his rug, and, pipe in mouth, and something hot at elbow, we chatted and smoked till bed time.

The next day we reached Marlborough. At Marlborough I saw a strange sight. For miles round the settlement the ground is covered by a dense forest of lofty trees, every one of which is dead! Years ago, a severe frost came, and in a single night blighted them all, and there they stand—grey, ghastly, whitened skeletons. Through this forest a small river, the Nive, flows past Marlborough. It looked desolate in the extreme, with its banks naked and unclothed by a single green leaf.

The stream divides what the colonists call the "New Country," from the settled districts of the island. From Marlborough to Mount Charles, where there is a shepherd's hut, is about fourteen miles. We arrived there about three o'clock the following afternoon.

Mount Charles is close to Lake St. Clair; and, after a hearty dinner of chops, with "damper" (bush bread) and tea, we took one of the shepherds as guide, and walked to the lake. We found a convenient spot for a camp, and soon made things comfortable. I got the camera, &c., ready for a busy day's work on the morrow, and my friend Stedley occupied himself in cleaning a double-barrelled gun, wherewith it was his intention to shoot some of the black swans which abound on the lake.

The next morning I started along the shore of the river Derwent (which issues from Lake St. Clair), and managed to get a fine view of the picturesque rapids close to the entrance of the river. Two or three hours passed very pleasantly. I exposed plate after plate, as the views were endlessly varying, and everywhere charming; the lake itself is a grand sheet of water, and the thick, sombre woods grow close along the margin, here and there varied by a rocky beach, or sometimes a cliff, with tall, celery-topped pines hanging along the summit, and reflected finely in the deep black water below. As an experiment (having plenty of plates), I exposed one picture for thirty seconds, and a second plate at the same view for two minutes, intending to try whether by different methods of development an equal result might not be obtained in both cases. By the way, in case any of my

* Continued from p. 213.

readers should think the exposures rather scanty for collodio-albumen plates, I may here mention that the view in question was well lit up by the sun, and that the instrument used was a binocular stereoscopic camera, with double combinations. What degree of success I had will appear hereafter.

As I was returning to the camp after my operations, and passing by a number of tall reeds growing into the water for some distance, I heard the sudden report of a gun, followed by a direful howl and shout of anguish from the reeds—"Ach! Mother av Moses; Oi'm shot did—Oi'm shot did!" Hastening towards the sound, I discovered Mr. O'Corcoran "in a state of innocence" sitting in the shallow water and fervently invoking every saint in the calendar. The fact was, he had gone for a bathe, and Studley, who was on the other side of the reeds, and did not notice him, fired at a swan, and hit O'Corcoran by mistake. On examining him, however, we found the shot had hardly left a mark—it had, luckily, come too far to do serious damage.

After three days spent in photography round the Lake, we returned to Hobarton, and I set to work to develop my plates. On the journey, I had carried them in an air-tight tin box with grooves, changing the plates each evening by the firelight.

The first I developed were those exposed at the same view, one thirty and the other a hundred and twenty seconds. Moistening the first one thoroughly, I put it on a carefully levelled stand, and covered it with plenty of the following solution. Pyrogallie acid, $\frac{1}{2}$ grain; glacial acetic acid, 1 drachm; distilled water, 1 ounce; 20-grain solution of nitrate silver, 2 drops. In about four hours the details were slightly visible, and I then poured off the developer, washed the plate carefully, placed it in water at about 120° or 130° F., and then completed the development with a warm solution of pyrogallie acid, $1\frac{1}{2}$ grain; glacial acetic acid, 15 drops; distilled water, $\frac{1}{2}$ ounce; adding 20 grains solution of nitrate silver as required.

In this way the details were perfectly brought out, with fair contrasts of light and shade, and no tendency to reduce harshness from under-exposure.

The other plate (exposed two minutes), I developed in the usual manner, with pyrogallie acid, 2 grains; glacial acetic acid, $\frac{1}{2}$ drachm; distilled water, 1 ounce; adding nitrate of silver as required.

When finished, few people could tell the difference between the two pictures.

The other plates also turned out for the most part satisfactorily, some few were failures; but on the whole I had reason to be well satisfied with my success.

Besides my excursion to Lake St. Clair, I made many other journeys among the scenery of this beautiful island. Sometimes successful, at other times failing, always satisfied at gaining fresh experiences, I passed many pleasant weeks wandering with the camera among its mountains, its lakes, and its rivers; meeting, wherever I went, with kindness and hospitality alike from all classes of people. Since my return, I have always looked back to my trip to the colonies as one of the pleasantest years of my life, and my advice to a brother photographer who does not mind a long voyage, is, "Go and see Tasmania."

PAUL RICOCHET.

TANNIN NEGATIVES FOR ENLARGEMENT.

BY M. JULLIET.*

M. LACON, in giving M. Juliet's method in *Le Moniteur* remarks, that the latter gentleman, who is an operator in the photographic establishment of M. Ferric at Mans, has for a long time been engaged in very successful enlargement, using the solar camera (we presume Woodward's, misspelt Woodhoard) and the heliostat of Leon Foucault. The best

* *Moniteur de la Photographie.*

conditions of amplification, as regards apparatus being secured, it is to the quality of the negative he gives special attention, regarding excellent results as depending mainly thereon. For obtaining his negatives, he uses the tannin process; the details of his method follow:—

Collodion.

Alcohol	4 $\frac{1}{2}$ ounces.
Ether	6 $\frac{1}{2}$ "
Gun cotton	40 grains
Iodide of ammonium	25 "
" cadmium	15 "
Bromide of ammonium	2 $\frac{1}{2}$ "
" cadmium	2 $\frac{1}{4}$ "
Iodine, pure	1 "

Let the collodion rest for a month or six weeks, when the red colour it possessed at first will have changed to yellow; and it will yield a very fine and tenacious film.

Bath of Nitrate of Silver.

Nitrate of silver, crystallized	26 grains
Water	1 ounce
Acetic acid	15 minims.

Let the plate remain at least a minute or two in the bath; wash in the ordinary way.

Tannin Solution.

Tannin	26 grammes
Distilled water	1 ounce
Alcohol	10 ounces.

Pour on as usual.

Development.

For negatives to be amplified make the following solutions:

No. 1.—Pyrogallie acid	1 grain
Water	5 drachms
Acetic acid	25 minims.
Alcohol	10 "
No. 2.—Gallic Acid to saturation.			
No. 3.—Nitrate of silver, crystallized	3 grains
Water	100 minims.
Acetic acid	5 "

Filter each solution. After exposure I take the plate, and, having previously varnished round the edges with a good varnish, I moisten the film with a little distilled water, without washing. I next pour upon the plate sufficient of solution No. 3 to cover it, and let it remain for at least a minute, during which time I mix in a graduated measure the following:—

Solution No. 1	80 minims
Do. No. 2	4 drachms.

In this I pour about twenty drops of acetate of ammonia. I stir the mixture, and, having poured off the solution with which it was covered, and drained well, I pour on this mixture. The image starts up at once. Keep the plate in motion until the solution becomes turbid, then pour it off, wash well, and then fix with hyposulphite, as sufficient vigour will have been obtained. If now the exposure is seen to have been too short, and all the details are not out, it is necessary to begin again, at all times having care to avoid too great intensity.

This method of developing has a great advantage in producing negatives for enlargement; the negatives can be very fully exposed without fear of producing the red colour given by pyrogallie acid alone, a colour which materially retards the production of prints by the solar camera.

PHOTOLITHOGRAPHY.

BY P. LISEGGANO.

An ingenious Viennese, M. Quaglio, has communicated to the Photographic Society of Vienna, a new process of photolithography, which gives superior results.

M. Quaglio employs *oleate of silver*, or silver soap, which he prepares by precipitating a solution of Marseilles soap by means of nitrate of silver. The silver soap is a yellowish white body, soft, like wax. It is rapidly decomposed under the influence of the sun: 5 to 7 minutes suffice to blacken it completely. It is possible that this substance may some day be much employed in photography; we can put it on metals, wood, ground glass, stone, &c. Exposed to light under a negative, it yields a proof of a fine glossy black colour. The proof is fixed with diluted hydrochloric acid, and afterwards with hyposulphite of soda or cyanide of potassium.

In creating his new process, M. Quaglio remembered the theory of lithography: upon a stone composed of carbonate of lime, he makes a design with the aid of black soap (oleate of soda); the stone is covered with diluted acid (either nitric or hydrochloric.) Decomposition takes place, the soda of the soap combines with the acid, and the oleic acid forms with the lime of the stone, oleate of lime, a fatty body, insoluble in water. In covering the stone with a solution of gum arabic, the latter penetrates the stone only in those places where there is no oleate of lime; if we moisten the stone, the parts where the gum arabic has penetrated will not receive the oily ink, which attaches itself only to the oleate of lime.

M. Quaglio covers the grained lithographic stone with a solution of gum arabic, and washes it with water after it has been several hours dry. The stone is then covered with the silver soap by means of a small tuft of flannel, it is then exposed under a negative in the sunshine for half an hour. The proof comes perfectly clear and fine. The stone is washed in rectified naphtha, gummed and blacked as ordinary lithographic stones are blackened, by dipping a sponge in gum, essence of turpentine and wax colour, which is passed over the design.

In the author's experiments, a portrait from nature, 3½ inches by 4, was reproduced on the stone in the manner described, and a proof taken with all the shades and half-tones. By blacking the design four or five times, and treating it as an ordinary lithographic stone, two hundred perfectly successful proofs were obtained.—*Le Moniteur de la Photographie*.

YELLOW VARNISH FOR THE WINDOWS OF AN OPERATING ROOM.

This varnish consists of a mixture of the following substances:—

Benzine	200 parts.
Orleans	40 "
Gamboge	40 "
Elemi Resin	1 part.
Dammar	1 "

The solid substances are pulverized and dissolved in the benzine. The filtered solution is poured upon the glass in the same manner as collodion.—*Le Moniteur de la Photographie*.

ON A NEW KIND OF MINIATURE, POSSESSING APPARENT SOLIDITY BY MEANS OF A COMBINATION OF PRISMS IN CONTACT THEREWITH.

BY HENRY SWAN.*

THE invention I have the honour of bringing under your notice this day is new, and the effect very beautiful, but it is neither for its novelty nor for its beauty that I would chiefly claim attention, but because in its application to miniature portraiture we find we have the means of adding greatly to our power of defining form and expression. So much so that it is by no means unusual for me to find that the same photographic plates which give an unsatisfactory likeness when printed as an ordinary

flat portrait, will, when printed and used for this kind of portrait, render the expression so much more perfectly, that the likeness is at once far more pleasing and far more truthful. Indeed, a careful comparison of a considerable number of the same pictures shown both as flat portraits and as portraits in relief will soon satisfy the artist that there are many niceties of form and expression which flat portraiture is wholly inadequate to render. But I trust that if the specimens I shall now place before you be not sufficient to show you that we have here great additional power of expression placed at our command, it is only because you have not here the same means of forming an opinion that you would have had these been portraits of your own personal friends. The novelty will wear off, and the eye will become accustomed to their beauty, but the power of giving more of the truth, more of the living soul to the likeness of one's friend, will remain, and remain to be felt the more, the more we become familiar with these vision-like images.

As to the means by which we are enabled to catch these Lilliputian "doubles," and imbed them apparently in the crystal as flies in amber; those among you who are conversant with the phenomena of binocular vision will, no doubt, have already guessed that each portrait is compounded of two pictures, and is in itself a stereoscopic apparatus. And such, indeed, is the case. The catching of the images is done by the ordinary modes of obtaining transparent pictures on glass; the union and combination of the two flat pictures so as to produce the true stereoscopic image, I manage by taking two rectangular prisms of flint glass, or crystal ground to an angle of about 39° or 40°. These two prisms I place together, with their widest sides in contact, or nearly so, so as to form one solid quadrangular prism, divided lengthwise by a thin film of air. Now if I stick a blue wafer on one side of this combination, and a red one at the back, I shall find that, when I look straight at this combination, the rays which reach one of my eyes are those which are transmitted directly through the prisms, so that with this eye I see the object which lies at the back. On the contrary, the rays which reach the other eye are not from the back, but from the side only, as they are reflected from the surfaces of the prisms where they touch either. Hence with this eye we see by reflection the object at the side, which, however, appears to be at the back, like the other. Thus, if I stick the red wafer at the back and the blue one at the side of this combination, with my left eye I shall see the red wafer, with my right eye the blue one, which will occupy precisely the same position. If now I look with both eyes I shall see apparently but one wafer, and that of a purple hue, this being the result of the red and blue images being superposed on each other.

In fact, if we draw a line perpendicular to the surface of the prism next the eye, all the rays which fall on one side of that line will suffer total reflection from the inner oblique surface of this prism, while nearly all the rays which fall on the other side of this line will be transmitted direct through the two prisms.

If now we substitute for the red and blue wafers the two slightly dissimilar pictures which constitute the stereoscopic pair, we, of course, obtain the image apparently solid. It, however, requires some experience and skill in mounting the transparent pictures, as, if they are not set rightly, they may distress the eye, which should have the same feeling of ease as though the image were of carved ivory.

In thus bringing before you an invention which carries the art of miniature portraiture a step further than has hitherto been done, I should like to conclude my description of the simple means by which this has been attained by a few words on what we may expect to get from this branch of human art—remarks which are not the less needed now that this kind of representation, in the form of the carte de visite, has become almost obtrusive at our social gatherings.

I know there are some who consider that it is mainly to vanity and egotism that we may attribute the wide-spread popularity to which these have now attained. To my mind vanity and egotism quite as often get from them a wholesome rebuke. It is rare for a first portrait to please. It falls far below the sort of ideal we have set up in our own minds as to the appearance we present to the gaze of the unthinking multitude.

There are, however, other phases of feeling which have a much larger share in the delight we experience in turning over these sun-stained tablets. Right on the surface lies natural affection, giving an interest and meaning to faces and forms, that to us, who know not the originals—have never laughed,

* Read in Section A, British Association, at Newcastle, on Tuesday, September 1st.

played, sung, danced, or wept with them—may seem but a little better than those displays of elegance we meet with in the windows of the enterprising milliners and tailors.

Then, again, men, yes, and women too, experience a glad sense of relief at their escape from the silly, stock-flatteries of the second and third-rate miniature painters. I do not say this in undue disparagement of these men. They painted for their living. They gave what best insured that living, and it is great cause of thankfulness photographers have not the same power of modifying their productions to meet the requirements, real or fancied, of their subjects. The ordinary photographer is mostly limited in his efforts to the trying, as far as his means will permit, to show how much the form and figure of his sitter would adorn princely halls, had it pleased Providence to place him in such a station, efforts which too often are not sufficiently seconded by his uneasy subject. However this may be, it is certain that we do feel that there is and must be a considerable amount of genuineness about a photographic portrait. We know that if it does not exactly fulfil our ideal of the man, yet that at the time he was taken, he must have looked very much after that fashion, and, at the worst, it is some satisfaction to find that there is so much in common between us and this and the other great man, that it is perfectly possible for him to look sulky or foolish under the same circumstances that makes us look the same. In further proof of this genuineness you will find it often not a little amusing, as well as instructive, to compare a portrait which has filtered through two minds, the painter's and the engraver's, into mere vapidity, with that which comes from the emotionless glass, recording every unconscious grace or conscious awkwardness.

There is yet another meaning which may be read from the gilded pages of a lady's portrait album. If only we had the cypher, so that the writing were more easily legible, here lies the most truthful records of life yet possible for us. We may look on many a human habitation, and be able to make but a very faint guess at the history of its inmate. It is not so with these

fleshy habitations. They are built up by the spirit within. The pen of the recording angel is no fiction; even here on earth, every living spirit fulfils that office and every varying play of light and shade tells its tale of the human soul within. Ay, and as in a Gothic cathedral, we trace one part as the work of an age of rude force, another of skilled mastery, or the gentle cunning of a sensitive soul and laud, and perhaps another of dull ostentation and empty pride; so in every truthful portrait we may see plainly or dimly, according to the perception God has given us, how this man has been builded up. How, perhaps, at some time or another, he has had frank, outspoken freedom for ancestors, and has inherited the same nature, a nature that both will not, and cannot live, except in freedom. Another is a born vassal, and seems a valet in his master's clothes. Some show cruel, wolfish eyes, while others have the gentle lustre of the deer. There, too, is to be seen, plainly or dimly, according to the perception God hath bestowed, what the living man himself has built upon the foundations of the dead. Here is a front worn with toil, and scarred with fight, yet peace beneath. There, a desecrated ruin; so desecrated, so ruinous, that we can hardly trace that there is enough of the living spirit left to hold the whited sepulchre from crumbling to pieces.

Look on these portraits, and, if you have insight, you may give more than a guess at what the man *is*, though you may know little or nothing of the steps by which he came to his heights or depths. Thus, when you have your likeness taken you are having your history written, perhaps as fully as it ever will be. Every turn of the lip, every bend of the brow, the very hang of the fingers, tells its tale, saying, "In some past times, such and such influences have been at work to mould this man, and *now* we see how far they have been permitted to leave their stamp, the inward being, sooner or later, moulding the outward image, and its light ever shining more and more clearly through.

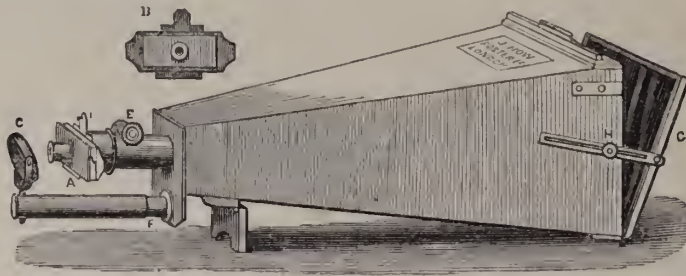

EDÉN'S MICROSCOPIC CAMERA.

SOME months ago we noticed an ingenious camera, invented by Mr. Edén, for producing either enlarged images of microscopic objects, or microscopic photographs of large objects. We learn that this instrument, which was patented, is manufactured by Mr. Howe, successor to Knight, of Foster Lane. We subjoin a diagram of the camera, together with Mr. Howe's description.

"The instrument described below has been invented for the purpose of taking magnified microscopic objects, minute photographs, commonly called micro-photographs, and miniature photographs from life, for rings, small lockets, &c. I will first describe the plan of taking magnified microscopic objects. The object to be taken, which is generally mounted on a slip of glass, 3×1 , is placed in the small camera box marked A in the general plan, and which box is fully drawn and marked B. There are four brass pins on which the mounted object to be taken is placed, and there are six longer pins which go round the edges of the glass plate and keep it in its place. These pins go through the small mahogany box, and are fastened into a brass plate which slides into dovetails, and can be taken in and out at pleasure. Attached to the small mahogany box is a brass lid lined with mahogany, and to which two silver springs

are fixed. This lid shuts down on the object, and is fastened by a small brass hook. On the top of the lid a piece of tube is screwed, into which slides another tube containing two lenses, and which act as a condenser to condense the light reflected from the mirror C. There is a lens inside the tube, at the end of which the box (A) is fixed, and this lens is adjusted by means of the milled head E. It shows a magnified image of the object on the ground glass at the end of the large camera. When the sensitized plate is ready, you remove the ground glass and substitute the sensitive plate in the usual manner. About two minutes' exposure will be required if the sunlight is reflected from the mirror, and ten minutes if an ordinary paraffin lamp is used. The mirror is adjusted by sliding it on the tube F. The pictures are printed from the negative in the usual manner. I will now proceed to describe the method of using the instrument for taking micro-photographs. These are taken from a negative which is fixed in a frame at the large end of the camera. The mirror C is removed from the small end of the camera by sliding it off the tube F. There is a large flat mirror at the large end of the camera fitted in a frame and marked G, and which is adjusted to any angle for the purpose of throwing the light on the negative, and when adjusted is clamped in its place, by means of the small

clamping screw H; you must now place a slip of glass, 3 x 1 inch, scratched with emery paper, the scratched side downwards, on the four pins previously described, and slide the condensing lens so as to get a sharp image of the scratches on the glass. Adjust the object glass by means of the milled head E, and while looking through the condensing lens (or, as it is used now, a focussing glass) make the image of the negative which is at the other end of the camera coincide with the scratches on the glass. Now remove the small camera from the dovetails, and take it in the dark chamber, close the shutter, and take the focussing glass out and put in its place a bit of cork. Remove the slip of glass with the scratches on, and substitute another with a small drop of collodion, prepared in the bath, and replace the box in the dovetails; expose for about ten seconds, and develop and fix in the usual manner. The way to take small full-length pictures from life is to unclamp the sliding bar, when the flat mirror can be removed. Take the negative out, and place the sitter opposite the large end of the camera. You then manipulate in the same manner as for the small micro-photographs."

PROCESS FOR PRINTING POSITIVES WITHOUT THE SALTS OF GOLD AND SILVER, AND FIXING IN PURE WATER WITHOUT HYPOSULPHITE OF SODA.

BY M. DE MOTILEFF.

I HAVE presented to the Photographic Society three kinds of positives taken without the salts of silver or gold: their colours are *blue*, *deep green*, and *intense ink-black*.

Before describing my peculiar processes, I must declare that they are based upon chemical reactions, known for a long time in chemistry, but which I have for the first time applied to photography; they are also results sought and studied for a very long period of time. Most of the photochemical reactions for obtaining positives without the salts of silver and gold, which were indicated by MM. Poitevin, Niece de Saint Victor, Schnauss, Hardwich, and others, I have experimented upon, and rejected as being too complicated and uncertain, or as affording too little sensibility to light, or, finally, as producing results which have no artistic value.

The idea pursued by me in my researches was to obtain the desired colour directly, by the action of light, preserving the whites perfect. I solved this problem affirmatively for blue and deep green colours; as to the black colour, up to the present time I obtain it by toning, but I hope to obtain it by the direct action of light.

Blue and Deep Green Colours.

I make use of chemical combinations completely different from those hitherto recommended; the paper is floated in the bath during five minutes. After becoming quite dry, it is exposed under a negative during a period of time varying from thirty to fifty minutes, according to the intensity of the negative, under the influence of the solar rays, the picture is produced of a blue or deep green colour, without the aid of a toning bath, which is indispensable in other processes; withdrawn from the toning bath, the proof is washed in ordinary water, and the operations are finished.

Considering the artistic value of the proofs, the simplicity of the manipulations, and the economy of the process, I believe it will prove useful for views, seascapes, for taking positives while travelling, but especially for wood engraving.

Up to the present time, we know of no method of photography on wood without a medium; this has always been a film interposed between the picture and the wood, either albumen, collodion, or other coating. This coating always obstructs the engraver, and by scaling under the tool renders the cutting almost impossible, while by my process we may

obtain very definite photographs on wood, without the aid of any coating, and even without altering the wood.

My materials applied to the surface of a lithographic stone, yield a perfect design; I am now occupied in seeking the means of rendering this design capable of receiving lithographic ink.

Photographs in very Intense Ink-Black.

The paper is placed on the bath during five minutes and dried, then exposed to the sun under a negative from twenty-five to fifty minutes, it is then withdrawn from the pressure frame, well washed in ordinary water and passed through a bath which transforms the picture into sesqui-oxide of iron; after washing in ordinary water, the proof is passed into a toning bath of gallic acid and other substances. This toning bath yields a very intense ink-black. I must add in this place, without wishing to boast of my process, that among the processes hitherto published for obtaining positives with gallate of iron, mine gives the best results. Having during the past year visited Dr. Schnauss, at Jena, I had an opportunity of seeing the results he had obtained by means of gallate of iron. I have also studied the other processes, and I can declare that my process is the only one which gives intense black, while preserving the whites in a satisfactory state.

The improvement that I am now seeking for my process is to increase the sensibility. In its present state the printing is nearly two and a half times slower than with chloride of silver, but we must also take into consideration that the washing after fixing is dispensed with. At the present time I am making experiments upon albumenized paper.

As to economy, a drachm of the sensitizing bath (20 per cent.) costs about a penny, the toning bath less, the stability of the proofs is not so great as that of carbon prints, but greater than that of proofs in chloride of silver; besides, that is a question of time. I have remarked that with time the blacks, instead of becoming weaker, grow more intense; the cause of which is, I think, the oxidation of the iron.

In the course of my photochemical experiments, I composed a bath which contained only of 1 part of nitrate of silver to 100 part of water, and with albumenized paper it gave very remarkable results.—*Le Moniteur de la Photographie.*

Correspondence.

FOREIGN SCIENCE.

[FROM OUR SPECIAL CORRESPONDENT.]

Paris, September 2nd, 1863.

It may perhaps be remembered that M. Dornbach, a young artist photographer, of America, met his death by the explosion of some gun-cotton he was packing in a cask, making use of a stick to force it down. It is questioned whether the explosion was caused by electricity or by friction, but the high temperature required to inflame gun-cotton may lead us to doubt whether the friction of the stick against the sides of the cask would evolve sufficient heat, although we cannot undertake to say it would be impossible. Dry gun-cotton is a highly electrical substance, developing a great quantity of resinous electricity by friction, and it is highly probable that in the operation which cost M. Dornbach his life an electrical spark inflamed the mass. Such is the opinion expressed by Dr. Phipson in the *Moniteur de la Photographie*, who has also the following observations on the development of free iodine in collodion:—

"Those who have read the papers of Mr. Hardwich, referring to the development of free iodine in collodion, will remember that he attributes it to the presence of ozone, or of the ozonized principle in ether, and it is true that in certain circumstances ether, like essence of turpentine, can engender allotropic oxygen. But hyponitric acid, N O₂, which exists in dissolved pyroxyline, acts exactly like ozone, and it will be difficult to prove the existence of the latter in presence of the former."

We know that pyroxyline is decomposed by the alkalis; we know also that iodide of potassium has an alkaline reaction, and that the iodide of ammonium is very easily decomposed. It is therefore, in my opinion, by the reaction of the alkaline iodides upon the pyroxyline of the collodion that free iodine is developed in that liquid, and not by the ozonization of the ether which has been exposed to air and light, as Mr. Hardwich has it. Light appears to favour this decomposition. The proof of what I advance is that the non-alkaline iodides, such as the iodide of cadmium, do not act upon the pyroxyline, and the collodion prepared with these latter usually remain colourless.

Messrs. Millon and Cornaille recommend for precipitating old silver baths the addition of proto-chloride of copper dissolved in ammonia. In this case, as every chemist knows, pure silver is precipitated, as when we make use of sulphate of iron.

Mr. Emerson Reynolds recommends for the preparation of this product the dissolving the black oxide of copper in hydrochloric acid, and, when it is all dissolved, to add ammonia, which produces a pale blue solution.

Upon this, Dr. Monckhoven remarks, in the *Bulletin Belge*, that he regrets to say the preparation indicated by Mr. Reynolds is practically very difficult. First, we must commence by procuring the black oxide of copper (employed for combustion in organic analyses), and then the operation does not always succeed. It is infinitely preferable to employ copper turnings, or very fine copper wire, boiled for half an hour in commercial hydrochloric acid, then throwing the whole into a large glass vase containing cold water. A white crystalline powder is precipitated, which is speedily collected in a bottle and ammonia added to it.

But let us say at once that the method indicated by MM. Millon and Cornaille is very inferior to that which consists in placing a plate of copper in the old silver baths. In the course of a few hours the silver is reduced. We can also employ a solution of sulphate of iron which is poured into the silver bath: all the silver is precipitated as if we had made use of ammoniacal protochloride of copper, only we are obliged to melt the metal, for it always contains bibasic sulphate of iron, which is separated by fusion.

M. Lacan makes the following communication to the readers of the *Moniteur de la Photographie*.

"We have had communicated to us a fact, the importance of which our readers will fully appreciate. About a year ago, M. Wothly announced that he was in possession of a new process of printing positives on paper without iodide or chloride of silver. Since that time M. Wothly has pursued his researches, and now his discovery is complete. The inventor has shown us a great number of specimens which leave no doubt as to the excellence of his method; many of the leading Parisian photographers who have also seen them are struck with the superiority presented by these pictures over those obtained by ordinary means. The proofs M. Wothly gave us to examine, and which are of all dimensions, from *cartes de visite* to enlarged portraits, resemble in aspect those produced upon enamelled paper. They are remarkable for limpidity and transparency. The whites are extremely pure, the half-tones of remarkable delicacy, and the shades very vigorous. Upon comparing them with positives upon chlorided paper taken from the same negatives, we cannot but perceive that they are infinitely preferable.

"The basis of the operation by which these pictures are produced are entirely new. As the silver salts are replaced by others much cheaper, an economy of 70 to 80 per cent, is obtained. While the time is abridged in the proportion of 1 to 4, the sensibility of the paper is four times greater, and the proofs offer every guarantee of permanence, hyposulphite of soda is not employed for fixing. Lastly, the method is as easily practised as those now employed, there being very little difference in the manipulations.

Upon this Dr. Van Monckhoven remarks—"As our friend M. Lacan calls the attention of his readers to M. Wothly's invention, and as it will be his duty to reply to all the ques-

tions which will be addressed to him on the subject, we put to him, *in the name of all his readers*, the following, — Do you wish to make known Mr. Wothly's process? Now that we have allowed the *Moniteur de la Photographie* to speak, we shall say to our readers that M. Wothly's pictures, which are now before us, greatly resemble those obtained by ordinary processes, but their violet hue is not so rich.

"We have undertaken a series of experiments to penetrate the secret of M. Wothly's process, and say, at once, that these proofs are obtained from silver and protoxide of iron. There is not, says our friend Lacan, in M. Wothly's proofs, either iodide or chloride of silver. We believe so; but if he says to us *non bromide*, we shall doubt it.

"In brief, we certainly consider the discovery made by M. Wothly as very interesting, but we wish to hear no more upon the subject, because our readers will derive no benefit from it. I appeal to my friend Dr. Schnauss, that he will make known through the journals his experiments on the proofs in question. I, on my part, will publish mine in the pages of the *Bulletin Belge*."

PHOTOGRAPHY IN CAPE TOWN.

SIR,—As a subscriber and constant reader of the *News* since it started, allow me to address a few lines to you, and, if I scramble on in an uninteresting way, pray put the missive into your rubbish basket. I have long intended to send you some views worthy of your acceptance, but years have crept by, and I will not wait longer. Twelve years ago I commenced with Talbot's process, but the collodion soon upset that for portraiture, and I have ever since been a steady follower of Archer. I frequently meet and hear of wonderful cases of the art being acquired in the short space of a few mouths or so, but I have been at it many years, and I honestly confess there is much to learn.

I hear and read a good deal about hot climates being unfavourable for the constant practice of photography, but, although it is undoubtedly unpleasant to work in a very high temperature, I do not see any material difference between South African and European productions. The greatest nuisance here is the difficulty of obtaining good albumenized paper—it is so variable in its quality. Mr. Matheson, in one of your recent numbers, gives a drawing of a glass house he suggests for hot climates, and accompanies it with some very excellent remarks, but I think a far better arrangement is that proposed by Mr. Sutton. I am now working in the fourth studio I have had in this colony; it is built on Sutton's plan, with the dimensions slightly altered. The side lights are twelve feet high by eight feet wide, the front light twelve feet wide by two feet high. The only objection I find is a deficiency of front light, and I am just having the alteration made suggested by your *News* of the 6th of March, fig. 2, to slope the sash from *b* to *d*, making it three feet wide. The house is built of brick, and is very cool compared to the old plan. The last house I had here was frightfully hot in the summer. In the summer of 1861 the thermometer stood at 105° at 9 o'clock A.M. The highest temperature, at any time of the day, in my present one, was 90°. I cannot conceive how Mr. Rejlander can obtain sufficient light in his new studio, though I readily admit that more failures arise from the excess than from a deficiency of light. Tissue paper on the glass softens the light very much. The suggestion made in the *News* to varnish it would, I think, make the light too strong for this climate.

I wish the manufacturers of apparatus would improve the dark slides they make for professional photographers. They should be stronger in every part, and an inclined groove, with sponge at the bottom, would ensure cleanliness and preserve the slide. The rolling presses would be much improved by having the steel plate with a thin layer of silver. Would it increase the expense materially?

In your article on "Silica," you observe that water extracts from glass potash and soda; may not this explain the

deterioration of some of our silver baths? I intended sending you a drawing of an instantaneous shutter I made about two years ago, but I do not suppose it would be worth while; I have not seen any that work exactly like it. It opened from the centre, and, for compound lenses, I did not find it answer; Dallmeyer's principle I prefer. We have not many amateurs here, but foremost among them is the Rev. Mr. Curtis; he is an ardent lover of the art. He has kindly given me a few of his stereographs to forward to you.—I remain, yours very obediently,

ARTHUR GREEN.

Cape Town, July 20, 1863.

[The stereographs enclosed are excellent specimens of photography, and very interesting. We shall have much pleasure in receiving the further letters promised from our correspondent.—Ed.]

PHOTOGRAPHS IN PRINTING INK.

STR.—Some time ago I sent Mr. Pouncy a few impressions of carbon prints on sheet gelatine, with a suggestion that the substance, from its transparency, would likely be useful for the production of transparent positives to be converted again into negatives, as the slowness of printing by this process will be much against its usefulness. He stated, in reply, that there was an objection to its use on account "of its tendency to move under the negative according to the temperature." However, in my experience, I have not found this to be the fact. The facility of making this substance, its even texture and transparency, combined with cheapness, induced me to give it a trial.

Sheet gelatine is manufactured in sheets of various sizes and shades of colour, and is now extensively used in the arts. Its manufacture being a trade secret, little is known about it, or how the beautiful surface is produced on the French prints which are exhibited in the stationers' windows. I have applied it with considerable effect in glazing photographs, &c., &c.

I, therefore, through the pages of the PHOTOGRAPHIC NEWS, give publicity to the manner in which sheets of gelatine can be made as well as the gloss on the surface of a photographic or any other print can be produced, with an important improvement of my own, giving, in addition to the gloss, a collodion surface perfectly waterproof, as well as the means of effectually securing on plate paper the transferred carbon print.

Procure a sheet of plate glass of any convenient size, or any number of them if you wish to do business extensively. Have them placed upon wooden racks, on supports, so that their surface be perfectly level when at rest, and out of the way of dust. Carefully clean them in the usual way for photography. Get from the butcher some ox gall, into which dip a piece of flannel or cloth and smear the top surface of the sheet of glass carefully and evenly and allow it to dry, passing on to the others. When all are dry, prepare some gelatine of the clearest description, having previously boiled in an earthenware vessel in which a small piece of alum has been introduced. Pour this gelatine solution from a small jug or bottle into the middle of each plate of glass, and be careful that it covers it all without overflowing the edges. In a few hours the gelatine will have set, and at this time it is that a damp print or photograph may be applied, face down upon the gelatine surface, taking care no air bubbles are introduced; if any press them out by turning over the glass and examining it. In two or three days the gelatine, and with it the print, will have dried, and when perfectly so, an incision is made with a penknife round the edges of the print. Lift one corner, when it will be found to rise, carrying with it the gelatine, retaining the gloss of the glass from which it has parted.

Dyes are introduced into the gelatine in its fluid state to impart the various shades of colour, and by allowing the gelatine to dry upon the glass, without covering it with

prints, &c., &c.; you can have sheets as large as the glass on which it is made. The improvement I have made for waterproofing the surface is the coating the glass plate with plain collodion thinned down instead of ox gall. The covering of its surface with the sensitive photographic ink previous to cutting the gelatine from the glass plate enables you to have a clean and even surface, and the transparency of the substance enables you to expose from the back, thereby effectually securing the half-tone; and if the gelatine be thin, you will have a finer detail than it is possible to obtain by any other means.

These prints, as well as those on paper, can be transferred to sized plate paper by following the directions here given:—

Damp the plate paper with a solution of strong clean gelatine; place the carbon print between damp blot sheets; have a lithographic press with clean stone on the carriage; lay the back of the print upon the stone, and the plate paper over it, gelatine face down, on the carbon print; pass all through press once or twice; take the pressed sheet out and allow it to dry, when it will be found that the gelatine on the plate paper holds all, the carbon print parting with its former surface, whether of sheet gelatine or paper.

In a future number I may have some further remarks to make on the subject.—I remain, yours respectfully,

FRANCIS S. BEATTY.

Photographic Notes and Queries.

LIQUID COLOURS FOR PHOTOGRAPHS.

STR.—A short time since, fluid colours for colouring photographic portraits were introduced to the notice of photographers, and I was induced to invest in a set, and on using them was much pleased with the quick and easy mode by which card portraits could be touched off, and in all the glories of bright crimson, blue, scarlet, and many coloured table covers, curtains, carpets, &c., &c., handed over to my patrons without the delay of the good old fashioned plan of water or oil colours. Of course a few were highly finished and placed in the window, and there in a few days every trace of colour vanished, leaving the photograph in no way improved by the "top dressing." My old colour box is again in its place, and I shall be rather more careful in my next experiment of saving time and trouble, when colouring photographs. Really, Mr. Editor, I think that dealers should be a little more careful in introducing these sort of things without testing them, as anything of this sort is likely to destroy faith, and cause unpleasantness between the photographer and his visitors.—Yours truly,

THOS. GULLIVER.

18, Union St., Swansea.

[So far as we have seen hitherto, most of the liquid colours applied to photographs have looked vulgar. Those we described a few months ago, for giving a general tint to the paper, are not fugitive: the specimens we tried retaining their colour perfectly.—Ed.]

PHOTOGRAPHIC DISCOVERIES.

STR.—I noticed the papers of Mr. Lewis in your two last numbers, but really I cannot see anything new in his transfer process first described. Is it any other than from Mr. Pouncy's last patent process? Are not the ingredients Mr. Lewis uses the same, only he manipulates somewhat differently? You will, doubtless, remember that in Mr. Pouncy's specification he speaks of his process as of peculiar advantage for transfers. There is no doubt but the process will become of great service in different branches of photography, but I think it is only right that parties making use of it in any way, should acknowledge to whom they are indebted, and not come before the world with something *new* of their own, when, in reality, it is not theirs, but borrowed.

Mr. Lewis is, perhaps, not aware that we are very jealous for the honour and rights of our countryman, whose name, in connection with photography, will, doubtless, last, and deservedly, as long as the art itself.—I remain, Sir, your obedient servant,

DORSET.

[We are also very jealous of seeing any inventor robbed of any share of the honour due to him, and award all praise to Mr. Pouncy for his skill, perseverance, and success. But our correspondent is in error, we think, in his deductions. The process described by Mr. Lewis is essentially different in method from that of Mr. Pouncy. We know Mr. Lewis to be an old experimentalist and a highly intelligent man, and see no reason whatever to doubt that the process is due to his own observation and experiments. Our correspondent probably forgets that the same materials of printer's ink or transfer ink, mixed with bichromate, have been used in photolithography before Mr. Pouncy had patented his process. Mr. Gibbon used copal varnish and linseed oil, mixed with bichromate, as described by Mr. McTear, eight months ago, at the Glasgow Society. Some have objected that this fact would vitiate Mr. Pouncy's patent. But we regard it as neither vitiating his patent, nor detracting from his merit, which consists, not in discovering new sensitive agencies, but in a clever adaptation and application of those already known.—ED.]

Talk in the Studio.

SENSITIVE PLATES FOR THE MARSEILLES COMPETITION.—M. Vidal, secretary to the Photographic Society at Marseilles, informs us that sensitive dry plates may pass the custom house without exposure to light, if certain precautions are taken. It is necessary that both the package and the declaration distinctly state that the parcel is in transit international, and that it contains sensitive photographic plates, which will be spoiled if they are exposed to daylight. We may here mention that the paragraphs in French and Italian given in our last contain one or two orthographic blunders, which escaped attention in the hurry of going to press. In line 8, for "aneun" read "aucun;" in line 12, for "osseroare" read "osserare;" and, in line 14, for "aggetti" read "oggetti." We should also remark that Mr. Cole uses two thicknesses of glass—one yellow and one green, to ensure protection.

To Correspondents.

- J. PENRICE.**—We regret to state that No. 198 is quite out of print. We may possibly be able at some time to procure a copy for you; but it is uncertain.
- H. P.**—On adding carbonate of soda to a bath containing acetic acid you form acetate of silver in the bath. Some portion of this will be reduced by long exposure to sunshine, and may then be filtered out; but it is difficult to get entirely rid of acetic acid when it is once added to a nitrate bath. 2. A good double combination is most suitable for instantaneous street views. 3. For groups a good portrait lens, or the triple. 4. For interiors a portrait lens, or the triple. 5. We have seen some good results produced by the lens you name. We did not see you or hear of your call at our office. Stamps value one shilling received for the case of necessity.
- B. W. B.**—It is not necessary to have any light on the camera. On the contrary, the more completely it is in shadow the better. All the light should be on the sitter. If your pictures are too dark it is from too short exposure or insensitiveness in your chemicals. A very weak bath would operate against sensitiveness and vigour.
- H. N.**—The brown patches arise from imperfect fixation, probably from the prints sticking together in the hypo, which may also possibly have been old or weak. The insoluble hyposulphite of silver has thus been formed which decomposes whilst the print is washing or on exposure to light and air, causing those dirty yellow or brown stains.
- G. G.**—It is probable from your description that your bath has been made of adulterated gutta-percha. When this is the case the bath may sometimes work well for years, and then begin to act injuriously from a slow process of decomposition having set in. 2. We have no personal knowledge of the practices of any of the houses you name. We know No. 1 personally, and deem him a respectable man.
- N.** We should attribute your trouble primarily to the collodion, or, rather, to the pyroxyline of which it was made. A change in the sample of collodion would be the first remedy to try. A less acid bath; perfectly clean and dry plates; and more perfect setting before immersion would aid in preventing the trouble. Your suggestion as to uneven drying causing the film to split is very likely correct; but, without the tendency in the collodion, it would not be sufficient to produce the result. Treating the plate with dilute gum water, or dilute albumen, before it dries is often found a remedy when the tendency exists.
- THOMAS R. BANKS.**—The formula you quote contains double the proper quantity of acetate of soda. The proper proportion is 30 grains to each grain of chloride of gold. Too much would cause slow toning.
- HISTORY.**—We do not clearly understand the class of papers to which you wish to refer. Historical allusions and accounts of the origin of different processes are to be found profusely scattered through our pages; but a consecutive history of photography remains to be written. You will probably best obtain what you require by searching through the indexes to the volumes of the PHOTOGRAPHIC NEWS. 2. The best proportion of double sulphate of iron and ammonia depends upon a variety of circumstances, such as the kind of collodion, light, subject, &c. We have known sufficient intensity produced at once when using it of various strengths, from 12 grains to 120 grains in an ounce of water.
- S. J. L.**—A variety of preparations have been used as substitutes for ground glass in mounting transparencies. One of the best is a "crystal" varnish or amber varnish, with a little white wax. Spirit varnish applied cold may be used, or thin starch.
- P. J.**—Make a solution of iodine in alcohol, about 10 grains to an ounce. With this rub the silver stain well, and then apply cyanide of potassium, and subsequently rinse with water.
- H. P.**—If prints discolour on bringing to the light after they have been in the hypo bath, it is from imperfect fixation. None of the prints you have forwarded appear, however, to suffer from that cause. Their defects arise from various causes. Primarily imperfect negatives, a tendency to hardness, with abundance of spots, prevailing. Some of the defects arise from under-printing; some from over-rapid toning, probably with a newly-mixed bath; and some from imperfections in the paper, the albumen having run in streaks and waves. As the prints are not numbered for reference, we cannot point out individually the evils in each.
- JOHN DAVIDSON.**—We do not know anything of the gentleman you name; but will make some inquiry.
- W. W. S.**—The deposit on the shadows, readily rubbing off, caused when using a newly-mixed iron developing solution, arises from too much reducing energy. The addition of more acetic acid, or of some old developing solution will prevent it. Keeping the developing solution a few days will also prevent it.
- J. B.**—The method of intensifying to which you refer is frequently very useful, and we have used it for some purposes for many years. The instantaneous pictures of Colonel Stuart Wortley were chiefly intensified by such a method, as you will see on reference to his paper in the PHOTOGRAPHIC NEWS, February 13th, 1863.
- CASTLEBERG.**—We have no knowledge whatever of the ability of the gentleman to whom you refer. He may, or may not, be very capable so far as we know. If you send us an address and stamped envelope we will send you the address of a gentleman we know.
- J. POUNCY.**—A few remarks on the subject in our next.
- J. H. G. 42.**—Mr. Bertsch's automatic camera is a clever little contrivance, with an ordinary single lens of so short a focus that all objects beyond a few feet distant are always in focus. You must generally receive the statements of inventors *cum grano salis*. The images, when enlarged to the extent described, show both distortion and loss of definition.
- DOUBLE X.**—Mr. Parkinson uses bromo-iodized collodion and iron development, as described in our last ALMANAC. Besides keeping his chemicals in good condition he has an excellent light, and attributes much of his rapidity, in a letter just received, to the use of Dallmeyer's No. 2 B lens. You will not gain in rapidity by the use of saccharo-sulphate of iron, but will probably gain a little in intensity.
- J. BURNS.**—If your prints turn yellow from under-fixation the appearance will be dirty and mottled. If they turn yellow from the liberation of sulphur they will appear at first of a very delicate yellow. This may arise from the use of an acid fixing bath, or from the toning bath being acid, and the print going into the hypo without rinsing. We shall be able to give you a much better opinion on seeing one of the results.
- T. C. F.**—For architectural work, especially if the camera have to be brought near to the building, a triple lens. For groups a good portrait lens is best and quickest; but to get satisfactory definition and rapidity you must have a good lens. Blue will be a better colour than white for the interior of your studio. The latter is glaring and causes too many reflections. Thin, light blue blinds may be used instead of white. The amount of glass you can dispense with entirely depends on the position and nature of the light. We should prefer to cut off what was necessary with blinds which could be removed in dark weather.
- X. X.**—The triple is the most suitable lens for interiors, giving absolutely straight lines. We fear that you scarcely understand the requirements of the work you are engaged upon. Convergence of the perpendiculars does not depend on the lens, but arises from tilting the camera. If this be necessary to get in the upper portions, you must employ at the same time a swing back.
- T. G.**—You will find it much better to put your sitters to face the east and have the side light from the north.
- C. COLLIS.**—The question of want of actinism during the hot weather is a curious and interesting one. We do not think that the putting the plates into the bath immediately or letting the film set well had much to do with the result. Neither has the presence of alcohol in the developer, its sole office being to make the solution flow well.
- SEA SIDE.**—No. 2 on your list we prefer. It is very rapid, gives exquisite definition, and freedom from distortion.
- Several Correspondents in our next.

scutivity history of photography remains to be written. You will probably best obtain what you require by searching through the indexes to the volumes of the PHOTOGRAPHIC NEWS. 2. The best proportion of double sulphate of iron and ammonia depends upon a variety of circumstances, such as the kind of collodion, light, subject, &c. We have known sufficient intensity produced at once when using it of various strengths, from 12 grains to 120 grains in an ounce of water.

- S. J. L.**—A variety of preparations have been used as substitutes for ground glass in mounting transparencies. One of the best is a "crystal" varnish or amber varnish, with a little white wax. Spirit varnish applied cold may be used, or thin starch.
- P. J.**—Make a solution of iodine in alcohol, about 10 grains to an ounce. With this rub the silver stain well, and then apply cyanide of potassium, and subsequently rinse with water.
- H. P.**—If prints discolour on bringing to the light after they have been in the hypo bath, it is from imperfect fixation. None of the prints you have forwarded appear, however, to suffer from that cause. Their defects arise from various causes. Primarily imperfect negatives, a tendency to hardness, with abundance of spots, prevailing. Some of the defects arise from under-printing; some from over-rapid toning, probably with a newly-mixed bath; and some from imperfections in the paper, the albumen having run in streaks and waves. As the prints are not numbered for reference, we cannot point out individually the evils in each.
- JOHN DAVIDSON.**—We do not know anything of the gentleman you name; but will make some inquiry.
- W. W. S.**—The deposit on the shadows, readily rubbing off, caused when using a newly-mixed iron developing solution, arises from too much reducing energy. The addition of more acetic acid, or of some old developing solution will prevent it. Keeping the developing solution a few days will also prevent it.
- J. B.**—The method of intensifying to which you refer is frequently very useful, and we have used it for some purposes for many years. The instantaneous pictures of Colonel Stuart Wortley were chiefly intensified by such a method, as you will see on reference to his paper in the PHOTOGRAPHIC NEWS, February 13th, 1863.
- CASTLEBERG.**—We have no knowledge whatever of the ability of the gentleman to whom you refer. He may, or may not, be very capable so far as we know. If you send us an address and stamped envelope we will send you the address of a gentleman we know.
- J. POUNCY.**—A few remarks on the subject in our next.
- J. H. G. 42.**—Mr. Bertsch's automatic camera is a clever little contrivance, with an ordinary single lens of so short a focus that all objects beyond a few feet distant are always in focus. You must generally receive the statements of inventors *cum grano salis*. The images, when enlarged to the extent described, show both distortion and loss of definition.
- DOUBLE X.**—Mr. Parkinson uses bromo-iodized collodion and iron development, as described in our last ALMANAC. Besides keeping his chemicals in good condition he has an excellent light, and attributes much of his rapidity, in a letter just received, to the use of Dallmeyer's No. 2 B lens. You will not gain in rapidity by the use of saccharo-sulphate of iron, but will probably gain a little in intensity.
- J. BURNS.**—If your prints turn yellow from under-fixation the appearance will be dirty and mottled. If they turn yellow from the liberation of sulphur they will appear at first of a very delicate yellow. This may arise from the use of an acid fixing bath, or from the toning bath being acid, and the print going into the hypo without rinsing. We shall be able to give you a much better opinion on seeing one of the results.
- T. C. F.**—For architectural work, especially if the camera have to be brought near to the building, a triple lens. For groups a good portrait lens is best and quickest; but to get satisfactory definition and rapidity you must have a good lens. Blue will be a better colour than white for the interior of your studio. The latter is glaring and causes too many reflections. Thin, light blue blinds may be used instead of white. The amount of glass you can dispense with entirely depends on the position and nature of the light. We should prefer to cut off what was necessary with blinds which could be removed in dark weather.
- X. X.**—The triple is the most suitable lens for interiors, giving absolutely straight lines. We fear that you scarcely understand the requirements of the work you are engaged upon. Convergence of the perpendiculars does not depend on the lens, but arises from tilting the camera. If this be necessary to get in the upper portions, you must employ at the same time a swing back.
- T. G.**—You will find it much better to put your sitters to face the east and have the side light from the north.
- C. COLLIS.**—The question of want of actinism during the hot weather is a curious and interesting one. We do not think that the putting the plates into the bath immediately or letting the film set well had much to do with the result. Neither has the presence of alcohol in the developer, its sole office being to make the solution flow well.
- SEA SIDE.**—No. 2 on your list we prefer. It is very rapid, gives exquisite definition, and freedom from distortion.
- Several Correspondents in our next.

Photographs Registered during the Past Week.

- MR. GEORGE HENRY VICKERS, Llandudno, North Wales,
Photograph of Rev. H. Rees.
- MR. JOHN M. BURGESS, Lower Goat Lane, Norwich,
Two Photographs of Henry Tillett, Esq.
- MR. JOHN GARNETT, Post Office, Windermere,
Photograph of the *Fairy Queen*, Stearn Yacht, the property of
J. G. M. Ridehalgh, Esq.

* The Publisher respectfully requests that all remittances above 3s. may be made by Post-Office Orders, payable to THOMAS PIPER, at the Chief Office, St. Martin's-Grand, Sunnyside 3s. may be remitted in postage stamps.

THE PHOTOGRAPHIC NEWS.

VOL. VII. No. 262.—September 11, 1863.

CONTENTS.

	PAGE		PAGE
Chloride of Lime and Acetate of Soda in the Toning Bath.....	433	On a New Method of Measuring the Chemical Action of the Sun's	
The Photographic Exchange Club	434	Rays. By Dr. T. L. Phipson, F.C.S.	439
The Manufacture of Photographic Collodion	434	British Association for the Advancement of Science—Report of	
On the Composition of the Photographic Picture. By Eugene		the Kew Committee, &c.	441
Sahler	436	Correspondence—Formic Acid an Accelerator	443
Formic Acid. By Z. L. Godimus	436	Photographic Notes and Queries—Image on the Retina of a	
Waldack and Deltenre's Portable Laboratory. By Dr. Klein ...	437	Dead Eye	444
Photography on Wood. By M. Eugene Baroux	438	Talk in the Studio	444
Coloured Photographs	438	To Correspondents	444
Photo-Electric Engraving, &c. By Duncan Dallas	439	Photographs Registered during the past Week	444

CHLORIDE OF LIME AND ACETATE OF SODA IN THE TONING BATH.

THE use of chloride of lime in the gold toning bath seems to result in very great success or very great failure. Experimentalists are either charmed with its results and enthusiastic in its praise, or disgusted with it and altogether sceptical as to its value. When recently we recalled attention to it and gave some verified formula, it was simply to meet certain inquiries, and instruct those who wished to obtain in portraiture fine black tones. The discussion of the subject has, however, created an immense amount of interest, and we have been inundated with letters seeking for information or detailing results. Some photographers have signally failed to obtain anything satisfactory, bleaching and mealiness alone resulting. The majority of the letters have, however, been enthusiastic in praising the results obtained.

Mr. Parkinson, of Dieppe, whose tones pleased us so highly a couple of months ago, has just sent us a batch of specimens, which, as rich, pure blacks, are superb. He has also sent us a long account of his toning experiments from which we shall make one or two extracts. The first mentioned formula, in which acetate of soda is used, as well as the salts of lime, is described as giving the best results with the least trouble and risk of failure; the prints to which we have just referred having been toned by it. Mr. Parkinson says:—

The acetate of soda and lime has proved most successful with me, and annexed I beg to hand you the formula I have found most successful; it will, I hope, help to put an end to mealiness. At the same time I beg to forward you other formulae that I have used with good success.

Into a bottle put the following:—

Chloride of lime	3 grammes
Acetate of soda	8 "
Carbonate of lime	8 "
Distilled water	100 "

Take 5 grammes of this solution and add to 1 litre of common water, shaking well, and then add a quarter of a gramme of chloride of gold. This is made up in the morning and generally used six or seven hours afterwards; it may be kept longer, but this is about the time we generally use it. The paper is floated for five minutes on 80 grains solution of nitrate of silver, slightly acid with acetic acid. The prints are slightly over-printed, well washed in several waters, and fixed in a nearly saturated solution of hyposulphite of soda.

The prints are put into the toning bath all together, and we find that one litre will tone from 120 to 150 cartes de visite, and will take about an hour to complete the whole. With this bath nearly any shade may be obtained, according to the length of time the prints are left in it. This is exactly as we use it, and I have tried it with several papers with the same success.

Annexed I beg to hand you other formulae I have used, but the first enumerated is my "Eureka" and my "Excelsior," and I am convinced that I shall be helping those in need if they only use it with a little judgment and patience.

From some of the formulae that follow, it appears Mr.

Parkinson has tried mixtures of almost all other toning baths, but as they tend rather to complexity than simplicity, it is, perhaps, not desirable to enter into detail, seeing that the results do not surpass, or perhaps equal, those of the more simple formula already given. One bath is similar to the formula published by Le Gray some years ago, and contains one grain each of chloride of gold, chloride of lime, and chloride of sodium, in five ounces of water. Some others follow, but with the reiterated remark that whilst they give good result, the first is the best; we shall not, therefore, quote any further.

We have also received a communication from Mr. H. Cooper, Jun., together with some exceedingly fine-toned specimens, possessing the characteristic warm blacks, which seems to be the general result of the lime bath wherever it is successfully used. We subjoin Mr. Cooper's letter:—

DEAR SIR,—Upon returning to town after a month's absence, I was delighted to see in the NEWS for the 21st and 28th of August last, recommendations from Messrs. Parkinson's and Bartholomew for the use of lime and acetate of soda for toning. From a rather limited experience with this mixture, I can fully agree with all that these gentlemen say in praise of it.

Two months ago, upon reading and hearing so much in commendation of lime for toning, I determined to give it a trial, and at first was disappointed with the results. I then, as an experiment, mixed the lime bath with an acetate one, and proceeded to tone a few prints in it, and was agreeably surprised at the magnificent tones produced, which were unequalled by anything I had met with previously: they were just the tint I had for a long time desired to obtain—a warm, purple black, without the least trace of inkiness. I afterwards made four or five baths in the following manner, and which were equal in every respect to the first one:—

6 grains of chloride of gold and sodium (containing 3 grains of chloride of gold); from 6 to 9 grains of chloride of lime; and about 20 grains of carbonate of lime (common whiting) are dissolved in 20 ounces of boiling water and left in an open vessel to cool. When cold this mixture should be only slightly alkaline. If it be strongly so, and smell pungently of chlorine, it must be placed in a dish exposed to the air and kept warm till it is in the right condition, and in making the next bath care must be taken not to use so much chloride of lime. When the lime bath has been prepared as above, add 60 grains of acetate of soda. The bath may be used soon after mixing, but is better after it has stood a few days. Do not filter the excess of carbonate of lime from the solution, but leave it at the bottom of the bottle, and when the bath is returned to it, after use, well shake it up, and let it settle again.

Some other advantages of the bath recommended are, that the prints are wonderfully free from mealiness; that the solution does not spoil by keeping, whether it is used occasionally or not; and that the variety of tones easily produced by it is very great, otherwise I should not recommend it for general purposes, as, although the purple black is very valuable for some subjects, I prefer, for the ordinary tint, a rich brown. Now, this latter tone can be as easily produced by the lime and acetate combined as by the acetate alone, or even better.

The best way to use the lime bath is to make two solutions, one as I have directed, and the other in the same manner, but

containing a larger quantity of chloride of lime. The latter bath we will call No. 2; and I will now point out one or two cases where it may be employed with advantage; first, calling the reader's attention to the fact, that no prints doctored, as I shall describe, can come up to those produced upon paper newly sensitized from a bright vigorous negative, and toned in No. 1.

Firstly, when I have a *feeble* negative to print from, I use a paper strongly silvered, and expose to the solar rays till very much over-printed; on subjecting this to the action of the No. 2 bath, it will yield a very fair print, as, on account of the strong bleaching property of the excess of chloride of lime, the lights are cleared whilst the shadows are not appreciably weakened.

The second case is when the sensitized paper has become dissolved, either from keeping or from its having been exposed to the light. By printing deeply from a vigorous negative and toning with No. 2, nearly perfect prints will be produced for the reason just mentioned.

Of both these applications I have seen some striking examples. It will be obvious to every one that by mixing the two baths in different proportions any desired effect may be obtained.—I am yours truly,
H. COOPER, Jun.

THE PHOTOGRAPHIC EXCHANGE CLUB.

WE have received a communication from Mr. Howard, the Honorary Secretary of the Photographic Exchange Club, from which we learn with regret that it is in a very languishing condition, and seems likely, unless some steps are taken to give it new vigour, to share the common fate which has attended several other similar clubs. We think this a great pity. A free and spirited exchange system is one of the most pleasant stimulants to effort in photography, giving considerable additional zest to the production of fresh pictures. What is the reason of this state of inanition? We insert Mr. Howard's letter, and invite those of our readers interested in the matter to discuss the best means for giving new life to the undertaking.

DEAR SIR,—It is with great regret that I beg to call your attention, and likewise that of the members of the Photographic Exchange Club, to its very weak pulsations; indeed, I am afraid it will cease to exist if some vigorous measures are not taken by its members to infuse new life into it.

The contributions have been few and far between for some time past, and those consisting mostly of very indifferent photographs—some very bad indeed.

This is the worst feature, and makes the duties of Secretary very unpleasant. The labour of examining, sorting, and distributing the photographs among the members is considerably lightened by the contributions being of good quality, and is likewise attended with a great deal of pleasure, but the labour becomes irksome when one has to twist and turn to make things fit and go smoothly, and downright disagreeable when rejections form one-half of the monthly letters.

The second year of the club (under the existing arrangements), being very near its termination, I have been induced to write to you with a view of some alterations, and, I hope, improvements being made, and solicit suggestions from members to that effect.

After so much has been said, read, and written, the knowledge that so much bad photography stalks through the length and breadth of the land, is very discouraging.

The club numbers among its members many good photographers, and I hope they will, by their assistance and suggestions, assist and get the club out of its present difficulties.—Yours truly,

FRANK HOWARD.

Secretary, Photographic Exchange Club.
10, Lansdowne Road North, South Lambeth.

THE MANUFACTURE OF PHOTOGRAPHIC COLLODION.

BY W. L. NOYERRE.

THERE are few photographers who make their own collodion: the reason of this is obvious. There are many commercial collodions for the photographer to select from that are found to meet his requirements. To manufacture a

uniform article requires great care; if a suitable place be not procurable, it becomes an exceedingly disagreeable operation, and it occupies time, which the photographer can generally lay out more profitably. The consequence is, that as there are few who require information on the subject, so has very little been written about it. In perusing photographic works, we find numberless formulæ for developers, intensifying agents, toning baths, and other solutions employed in the art, but very seldom do we see a formula for collodion, which, after all, is the principal substance we have to work with. What has induced me to say anything on the subject, after giving such ample reasons why the general photographer has no need of the information, is the hope that what I have to say may be acceptable to those who practise the art abroad in the tropics, and other places where good collodion cannot be purchased.

In hot climates collodion rapidly decomposes; even supposing that a sample by a good maker can be procured, and that it is in good order when it reaches the photographer's hands, which I can say from experience is seldom the case, it often becomes decomposed before the stock is exhausted, and consequently the photographer is thrown back till his next supply arrives.

Now, as the substances employed in making collodion are procurable in most countries, and if obtained from England do not decompose like collodion, the photographer may often be independent and free from the above sources of failure and disappointment if he can make a collodion for himself. Let him buy it when he can get it good, but when he cannot purchase it he should know how to make it.

Whatever formula is employed, the same general rules apply, and almost the same anomalies will be met with. There are many formulæ that may be used, each yielding a good pyroxyline; one very simple, and producing uniform results, is that given by Mr. Wharton Simpson in the PHOTOGRAPHIC NEWS ALMANAC, the pyroxyline made by it is very well adapted for bromo-iodized collodion, and by slightly modifying the formula a cotton suitable for any kind of collodion may be produced. First to be considered are the chemicals and apparatus required.

It is important that a proper place be selected for the operation, where the fumes from the mixed acids may be carried away so as not to annoy the operator. A kitchen-range answers the purpose admirably; the fire will be required to heat a saucepan of water; on the hob will be found sufficient space for conducting the operation, and the draught will cause the poisonous fumes to go up the chimney. If the operator is obliged to manipulate in an ordinary room, the doors and windows should be opened so as to produce a draught through the room and carry the fumes away from the operator. In this way small quantities of pyroxyline may be prepared without inconvenience.

A deep jar will be required for containing the acid; it is best made of porcelain or glazed earthenware. An infusion jar is very convenient, as it is provided with a handle and cover. This article and a couple of glass spatulas for manipulating the cotton may be procured at Brown's Medical Glass Warehouse, Farringdon Street. A couple of slips of thick plate glass, or two stout glass rods tied together, will also answer the purpose.

A thermometer is necessary for testing the temperature. It must be accurate, and it is a good plan to have a pair of them to compare before immersing in the acids. Thermometers are made for chemical purposes with the scale marked on the tube, or an ordinary thermometer may be used. Take one graduated to about 200°, make marks on the stem with a file corresponding with 150°, 160°, and 170° on the scale, now detach the bulb from the scale, and it will be ready for use.

Scales and weights of the ordinary kind, turning to half a grain, are sufficiently accurate for weighing the chemicals, and also for testing the specific gravities by means of the specific gravity bottle.

Taking the specific gravity of liquids is a simple operation,

and may be done either with an hydrometer or a specific gravity bottle.

To ascertain with accuracy the density of liquids differing much from one another, two or three different hydrometers are necessary, whereas the specific gravity bottle may be used for liquids of any density. One constructed to hold 1,000 grains of distilled water at 60° answers very well for our purpose. A brass counterpoise is sold with it the exact weight of the empty bottle; the stopper is pierced with a hole, so that when the bottle is filled with the liquid to be tested a portion of it is displaced on inserting the stopper, thus the bottle can be exactly filled. It must be wiped quite dry, and the temperature of the liquid should be as near 60° Fah. as possible. Supposing the liquid to be sulphuric acid, the specific gravity of which is 1.840, place the bottle of acid in one pan of the scales and the counterpoise in the other, now add weights till the scales balance exactly. We shall find that the acid weighs 1,840 grains, which, divided by 1,000 (*i.e.*, the weight in grains of pure water the bottle will contain when full), and expressed as a decimal, gives the specific gravity of the acid; namely, 1.840. In the same manner the density of all liquids, whether lighter or heavier than water, may be estimated. The weight of the liquid to be tested being divided by 1,000 and the quotient expressed as a decimal will be its specific gravity. Bottles are sold containing only 500 grains of water, which are perhaps more convenient as not being so bulky. In using this bottle the weight of the liquid to be tested must be multiplied by 2 before dividing by 1,000.

A syphon is very useful for drawing off the collodion. After it has been mixed and allowed to settle down for a few days it may be made as follows:—Procure a large flat cork and a long glass tube; the length of the syphon must depend on the size of the bottle—an ordinary 40 ounce bottle will require one about a foot long—bend the glass tube over a spirit lamp at right angles about a foot from one end of it, make another bend again at right angles, about four inches further on, so that when passed through a hole in a cork held over the mouth of the bottle one end of it will reach nearly to the bottom of the bottle, and the other will hang down parallel to it on the outside. This should be a little longer than the piece inside the bottle. Another tube, about six inches long, must be passed about two inches through another hole in the cork, and bent in the middle to form a convenient mouth-piece. Suppose the bottle to contain collodion with a residue of undissolved pyroxyline at the bottom, press the cork tightly on the mouth of the bottle and adjust the syphon so that the end of it, inside the bottle, will reach within a short distance of the residue. Place a clean bottle under the other end of the tube to receive the collodion and blow gently through the short tube, pressing the cork tightly on the neck of the bottle all the time, taking care not to shake it. The collodion will rise in the tube and run over into the bottle placed to receive it. When the collodion begins to pour the blowing may be discontinued. When sufficient has passed over, remove the cork and tubes, and the latter should be washed out with ether and alcohol. If the collodion is allowed to set in them it will be almost impossible to clean them for another operation.

THE COTTON.

The cotton should be the best American cotton if procurable, and where this cannot be obtained the formula for the acids must be modified to suit the particular sample.

Different kinds of cotton vary in the length of the fibre and in the amount of resin by which it is encased; impure samples containing much resinous matter, absorb the acids with difficulty, the air bubbles formed in pressing the tufts of cotton under the acids are not easily got rid of, so that nitrous fumes are likely to be disengaged, which cause solution of the cotton: and even if this is prevented, a longer time is spent in immersing the cotton, which should be avoided, or the resulting pyroxyline will not be uniform, the first portions of cotton immersed being more acted on

than that which is put in afterwards. With cotton containing much resinous matter, less water must be added to the acids, or in using a formula in which no water is employed, the temperature may be lowered a few degrees, the resin appears to decompose a portion of the acid, and consequently causes it to act more energetically on the cotton; thus, the purer the cotton, the weaker may the acids be used.

When a very impure kind of cotton only can be obtained, such as is met with in some parts of India, it is impossible to obtain a uniform pyroxyline from it without first removing the resinous impurity; this may be done as recommended by Mr. Hardwich, a quarter of a pound of cotton being gently boiled for two hours in a gallon of water in which has been dissolved two ounces of potash; the best kind of cotton boiled in this solution will tinge the liquid a yellow colour, showing the existence of a small portion of resin, but a very impure sample will make the solution quite brown, and such a cotton could hardly be used with safety for pyroxyline without first freeing it of its impurification; after boiling, the cotton must be thoroughly washed till the washing water is no longer alkaline to test paper; it should then be pressed between cloths and well dried, either in the sun or by hanging on a line before the fire.

Cotton thus prepared when immersed in the acids, absorbs the liquid at once, like a sponge; it would therefore seem desirable always to prepare the cotton in this way, however good in order to facilitate its immersion in the acids; the plan is, however, found to be troublesome: the cotton gets tangled and twisted into lumps in the process of washing and drying, which makes the pulling out into tufts before immersion in the acids difficult and tedious; added to which the cotton must be watched while boiling, and water added from time to time to replace that which evaporates, or else the solution would become concentrated to such an extent that the alkali would act on the cotton and render it unfit for use; consequently, the operator will not find it worth while to go to the trouble of boiling it in the alkali if he can get a cotton which he can manipulate properly, and which is tolerably free from impurities.

It will be found convenient to purchase sufficient at one time to last for six months or a year's consumption, and on using another sample, he must be prepared for a difference in the pyroxyline, unless the temperature or the amount of water in the acids is slightly varied. It must be remembered that cotton always retains a little moisture, it does not seem necessary to dry it artificially before use: but if we were to dry it on one occasion, and neglect to do so for another batch of pyroxyline, the results would be different. Linen, paper, and other substances, have been recommended for photographic pyroxyline; but Mr. Hardwich, who has given great attention to the subject, is of opinion that no material is so suitable as cotton-wool.

SULPHURIC ACID.

The best commercial sulphuric acid is well suited for the manufacture of pyroxyline. In Mr. Simpson's formula, he gives 1.840 as the specific gravity of the acid he recommends. Mr. Hardwich advises the use of a stronger acid, having a density of 1.845; this is the strength of the best acid. An acid is often sold having a specific gravity 1.836; in using this acid a little more must be used in proportion to the quantity of nitric acid given in the formula, the exact quantity can only be ascertained by experiment.

Sulphuric acid, which is too weak to use, may be concentrated by heating in a Berlin porcelain dish on a sand bath. The acid has a great attraction for water, and absorbs it very readily from the atmosphere, it must therefore be kept in carefully stoppered bottles.

NITRIC ACID.

There are three kinds of nitric acid usually met with, namely, the ordinary nitric acid of commerce, having a specific gravity varying from 1.5 to 1.45. We are deceived as to the real strength of this acid by the presence of

sulphuric and hyponitric acid, with which it is contaminated, the latter impurity giving it a yellow, or, more often, a reddish tinge; it also contains chlorine.

Pure nitric acid is prepared from the above, its specific gravity is 1.5, and it is used for analysis.

The third kind is an acid not quite so concentrated as the last named, but free from chlorine and the other impurities which are found in the ordinary acid, its specific gravity is 1.42, but is sometimes as low as 1.36; when this acid can be obtained it is preferable, the difference in price is not great, and more uniform results can be obtained with it. A mixture of nitro-sulphuric acid, in which the impure kind of nitric acid is employed will act more energetically on the cotton than if the acid was pure, although the specific gravity of the former is the highest. This is chiefly due to the chlorine, which decomposes a portion of the nitric acid. More water will therefore be required in the mixture when the pure acid is employed.

When an acid having a less specific gravity than 1.36 is to be used, more sulphuric must be added in proportion to the nitric acid given in the formula, the quantity being determined by experiment; the resulting pyroxyline will, however, be inferior in quality to that obtained with the stronger acid. A weak acid may be concentrated to a density of 1.42 by evaporation in the same manner as recommended for sulphuric acid. As advised in the case of cotton, a supply of sulphuric and nitric acids should be laid in which will last for some time, the quantity having been once determined, to produce the kind of pyroxyline desired, there will be no difficulty in making every succeeding batch perfectly uniform till the stock is exhausted.

(To be continued.)

ON THE COMPOSITION OF THE PHOTOGRAPHIC PICTURE.

BY EUGENE SAHLER.*

4th Experiment.—I precipitated in a capsule, in the dark, some chloride of silver, and washed the precipitate.

I poured on one side only a solution of bichloride of mercury, and then exposed it to the light.

The effect produced is known in chemistry; the portion in contact with the bichloride remained white, the other portion was reduced; I separated the first, and put it in contact with some oxygenated water. A combination took place with the evolution of heat, and the formation of oxy-chloride of silver, but not of mercury; the presence of oxy-chloride of mercury would have been indicated by a colouration, but the compound remained perfectly white.

Exposure to the solar rays made the oxy-chloride of silver pass, in spite of the presence of the salt of mercury, through all the degrees of colour observed during the reduction of the chloride.

The bichloride of mercury, as well as heat, prevents the oxydation of the chloride of silver, which cannot then be reduced by light; the absorption of oxygen, therefore, precedes reduction, and the formation of oxy-chloride is a transitory state, without which this reduction is not possible.

In the case of the bromide and iodide, the bromine and iodine, more fixed than the chloride, remain in presence of the oxybromide or of the oxy-iodide formed, and prevent the reduction; the intervention of nitrate of silver becomes necessary to effect the decomposition.

The anomaly presented by the chloride of silver submitted to the two physical agents, has always urged me to seek a more rational solution than that furnished by the various hypotheses admitted. The following experiment proves to me that I was not on the wrong track.

5th Experiment.—I submitted a sensitized and washed plate to the action of oxygenated water, and, after the lapse of a few minutes, I exposed it rapidly, making use of a sliding cap; the proof obtained would have required

strengthening to print positives from, but it was sharp and free from fogging.

Oxygenated water will, therefore, produce the maximum of sensibility, working dry, and instantaneity with apparatus and light in the best conditions: the film being very sensitive, must be carefully protected from light.

Addenda.—Take a weak reducing agent—very acid sulphate of iron will answer—with a concentrated solution the reduction will take place upon the whole plate; pyrogallic acid united to the salts of alumina produces the same effect—complete blackness.

Take diluted oxygenated water, having care, in pouring it upon the plate after sensitizing and washing, that it does not touch the fingers, which would be stained by traces of the reducing bath, for it forms light streaks from one end of the plate to the other. The other operations are as ordinary; after exposure, immerse the plate in a bath of nitrate—strength, 3 or 4 per cent.—*Revue Photographique.*

FORMIC ACID.

BY Z. L. GODINUS.

It is important for photographic chemists to learn to prepare formic acid themselves,—first, because they can derive great advantages from this product, and also because the diversity of results obtained hitherto appear to result only from the light impurities in this acid. For it is very difficult to obtain it pure; and as, moreover, it is extracted by numerous processes, the foreign elements it may contain necessarily cause a difference in its properties. Let us then examine these different modes of preparation, and assume the task of experimenting on them; such, probably, are the only means of solving this difficult problem.

The least convenient process consists in causing a mixture of sulphuric acid and peroxide of manganese, or of sulphuric acid and bichromate of potassa, to react upon most organic substances, such as alcohol, sugar, starch, mannite, gum, citric and tartaric acids, etc. To this end we must dilute the sulphuric acid, and heat it in a glass retort by means of charcoal. The reaction then takes place, and the organic substance undergoes complete decomposition; one portion yields water and carbonic acid, the other is incompletely oxidized and yields formic acid, which is left in the retort—the carbonic acid is given off. The impurities of the mixture are afterwards separated, and we thus obtain formic acid more or less hydrated; but this mode of preparation gives insignificant quantities of formic acid.

A second process consists in operating as follows:—Introduce into a retort of the capacity of about ten pints—

1st. Oxalic acid, commercial (C ² O)...	35 ounces
2nd. Syrupy glycerine	35 "
3rd. Water	4 to 7 "

Care must be taken not to heat it above the temperature of 245° Fah., and in this particular the same recommendation applies to the first method. A vivid effervescence soon takes place, and, as in the preceding method, pure carbonic acid is disengaged. In about four and twenty hours, all the oxalic acid is decomposed; one portion of its carbon has formed carbonic acid, and the other formic acid, which is dissolved in the syrupy glycerine (which remains quite unchanged). It suffices afterwards to add successively some oxalic acid to the mixture and distil, to obtain formic acid indefinitely, for the operation is continuous. The product of the distillation contains all the formic acid, or nearly so. It is treated with carbonate of soda, and a formiate of soda results, which is first dried and then easily decomposed by sulphuric acid diluted with its volume of water. We can thus obtain about twelve ounces of formic acid for every 35 ounces of oxalic acid employed.

A third experiment may be made with hydrocyanic acid, water, and a strong acid. The following formula will clearly explain the result which takes place.

* Continued from p. 390.

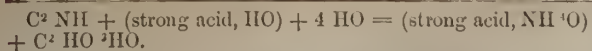

Very recently formic acid has been obtained by heating for several days, in glass receivers, oxide of carbon with caustic potassa or hydrate of potassa, slightly moistened. Sixty hours suffice for the carbonic oxide to become completely absorbed and transformed into formic acid. The reaction is as follows:—



Finally, if we desire to obtain formic acid at the maximum of concentration, we must pour the crude formic acid obtained by distilling the glycerine with the oxalic acid of which we have spoken, into a solution of acetate of lead.

The formiate of lead is very little soluble in cold water, so that it is almost entirely deposited in the course of a few hours, in the state of large crystals. It is purified by being redissolved in boiling water, which abandons it upon cooling in small prismatic crystals; we afterwards dry this formiate of lead in a long glass tube, heated over charcoal; then a current of sulphuretted hydrogen is passed over the formiate, converting the latter into sulphide of lead, and the monohydrated formic acid is condensed in the receiver provided for that purpose.

As to the properties of this latter acid, we have described nearly all of them in our previous article. (See p. 335.)—*Bulletin Belge de la Photographie.*

WALDACK AND DELTENRE'S PORTABLE LABORATORY.

BY DR. KLEIN.

FOR PHOTOGRAPHIC VIEWS.

THE employment of tents, or of dark rooms, of different forms, for out-of-door photography, is so inconvenient in the practice of this art, that, instead of being an amusement, it becomes, to the amateur, an onerous labour.

The tents employed are too large and too heavy to be easily carried about; they require a good deal of time to be fixed and repacked, and, moreover, they are very dear. Let us also add that with the least wind, the extension of the film of collodion becomes very difficult, and the negative obtained under these circumstances is very often riddled with small holes, caused by dust, or grains of sand. In consequence of these several inconveniences, the employment of tents is being abandoned, and, in their place, laboratories are employed in which the operations are performed, sheltered from wind and dust.

The various laboratories proposed may be divided into two classes:—

1st. Those into which the head and arms are introduced.

2nd. Those into which the arms only are introduced, and the operations carried on in the interior are examined through a window of orange-coloured glass, which intercepts the passage of the photogenic rays.

The first of these laboratories, among which we may specify that by Rouch, presents, moreover, this serious inconvenience, the operator is suffocated by heat and want of air. The second, on the other hand, very often do not permit of the photographic operations being easily carried on, in consequence of the restraint that the arrangement of the sleeves through which the arms are passed communicates to the movements.

The laboratory we are now about to describe presents none of these inconveniences. It permits free movements, and the operations are carried on outside.

The external dimensions of the laboratory are, height, 20 inches; width, 18½ inches; depth, 7 inches. It is furnished with dish, bottles, and support, and weighs only about 17 lbs., and is easily carried by a handle, or on the back like a knapsack.

The annexed woodcut gives a correct idea of it. The laboratory consists of a wooden box sustained by a very light

tripod. The linen screen is attached on one side to the upper part of the box, and on the other to the back, which falls so as to form a table; the screen is kept straight by a copper wire, and is furnished with sleeves. Upon the part falling at right angles forming the table, a bottom of vulcanized indian-rubber is nailed, furnished with a tube to carry off liquids. On the opposite side is found a door which, in the woodcut, is represented open. The light is admitted by a window of orange-coloured glass, in the roof of the laboratory, as well as by the door, and is thrown upon the indian-rubber which lines the table, where the collodion is applied and the development performed. The operations are examined through a pane of yellow glass fixed in the linen screen. The bath (vertical) is at the bottom of the laboratory, in a position inclined towards the operator, where also the bottles of collodion, developing solution, &c., are placed.

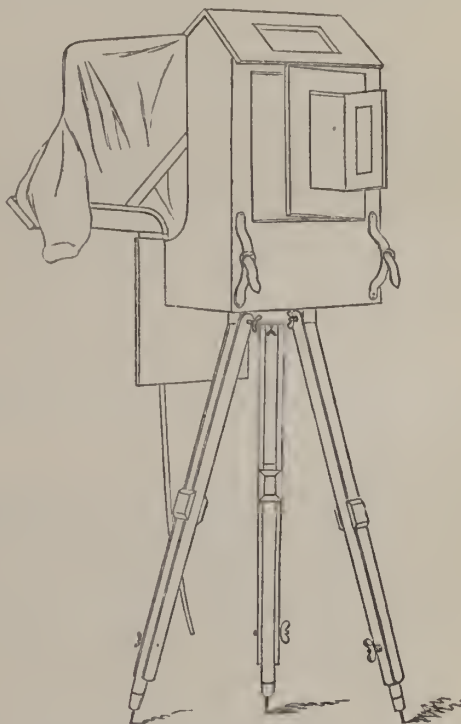

To make use of this laboratory, the operator introduces his arms into the sleeves and covers his head with the black screen as when focussing. The plate having been previously introduced through the door mentioned above, he proceeds to collodion and sensitize it, and these operations concluded, he puts the plate into the frame, taking care to replace it in the box after being used. The frame is then withdrawn from the box by the door and placed in the camera. The developing is performed in the same manner as the collodionizing. The white tint of the india-rubber lining of the table allows the operator to judge of the intensity of the negative, and, if necessary, of the strengthening performed immediately afterwards. The water necessary to be employed can be conveyed into the laboratory by an india-rubber tube attached to a bag of the same material, which serves as a reservoir, and is hung outside. The orifice of the tube is closed by means of an American clip.

The original idea of this portable laboratory belongs to Mr. Coleman Sellers, of Philadelphia. Notable alterations in it have been made by Messrs. Waldack and Deltenre, who, by means of ingenious improvements, have made it an indispensable *vade mecum* for the travelling photographer, both for dry and wet processes, by which he can satisfy

himself of the success of his picture on the spot by means of development. It may also be turned to excellent account at home in taking portraits, as it contains in a small space the materials and products necessary for operating.

This light, commodious, portable, and economical laboratory will not be long before it is in the hands of all photographers and amateurs, to whom it will render valuable service.—*Bulletin Belge de la Photographie*.

[From the stereograph of this dark box, with which Mr. Waldack favoured us, it appears to be one of the most convenient arrangements we have seen.—Ed. P. N.]

PHOTOGRAPHY ON WOOD.

BY M. EUGENE BAROUX.

ENGRAVING on wood, as is well known, requires two operations: 1st. The design is drawn upon a block of box wood, the surface of which is whitened with white lead: 2nd. The wood is then cut with the engraving tool in the whites, leaving the black lines in relief. The fidelity of a reproduction depends therefore upon both draughtsman and engraver. We substitute a photographic picture for the pencil drawing, on the boxwood itself, and thus obtain a fidelity, a delicacy of detail, an interpretation of the lightest shades, a perfect resemblance in fact to which the most skilful hand cannot attain.

This photographic picture is very distinct, the whites of the model are quite white, and the blacks very black, all the tones and half tones are perfectly distinct, and the minutest details are reproduced with the greatest exactness, however complex they may be, as well as the complete series of tones in their gradation. Hitherto, on the contrary, we have obtained on the block only a photograph without any whites, brown in every part, so that the engraver had the greatest difficulty to find a guide to his tool. All the details, in lines and in tints, traced or modelled, are thus found upon the wood, the engraver can render or neglect them at pleasure, according as he desires a more or less finished work; this is a question of time and cost.

The picture may be obtained of the same size as the object, or diminished, or enlarged, in any desired proportion.

An evident imperfection was the reversing the position of objects, in which the right became left and *vice versa*; thus a decoration, a scar, or the wing of a building were placed on the wrong side, destroying the integrity of the work, and reversing all the effects of light. By our process, we can at pleasure take the picture reversed or not, according to the exigencies of the case.

We can also take it from nature or from a photograph, or an engraving, or even an oil painting.

The whites of our picture are very solid, and like the rest of the picture resist the friction of the hand. Yet, if we wish to cancel a picture to substitute another, we have only to rub the surface with a piece of wet rag, and recommence on the same piece of wood.

If the attempts hitherto made have been unsuccessful, it is because the treatment of the wood by photographic substances rendered it unsuitable to receive the graving tool.

Very frequently the wood, the yellow colour of which is so necessary to the engraver, is found to be black or brown to a certain depth, or at least impregnated with substances which exposed by the cutting tool, quickly blacken in the light. Then the ground of the hollows becomes confused with the design being also black, from whence arises confusion of lines, undecided outline, and great difficulty in following the operation of the graver with certainty. And after the first-proof which can only be obtained by blackening all the parts in relief, nothing is perceptible but a uniform black tint, where retouches are impossible.

In our method, on the contrary, the wood is not attacked, not even on its surface, but shows everywhere its natural hue, so that the burin, by the lightest touch, removes the photographic film.

And this film is extremely thin. That is an indispensable condition; for, without it, the tool would attack the

wood only through the photographic design which must be removed before taking proofs, the wood, thus stript is found to be insufficiently hollowed, consequently too black, and leaves too much to be retouched.

We sometimes have a photographic coating that is too soft, which tears instead of cutting sharply under the tool; sometimes it is too dry, then it scales off at the slightest touch of the graver.

Frequently the photographic film forms a glossy surface like tissue paper, over which the pencil glides without marking, rendering all correction impossible. Upon our picture, the crayon marks vigorously; we can, therefore, correct and modify the model, and mark the lines if necessary, although a skilful engraver will not require them, his practised burin preferring the free and initiative essay, contenting itself with the indications of the various hues. According to circumstances we may mark a retouch with blacklead, indian ink, or the stump.

The engraving completed, if before taking a proof, we have not sufficiently cut into the wood, it will acquire in the light a reddish hue in the cut portions. We must not conclude from this that it is attacked, if it has not reddened during the engraving. It is an effect of the re-vivification of the sensitive film by water. To avoid it, it is only necessary to wash the block with a brush and spirits of wine in the dark.

Our block thus engraved gives casts with the same facility as ordinary engravings, and with more certainty, because it is hardened by our preparatives, as we have remarked in our various *cliches*.

COLOURED PHOTOGRAPHS.

M. DE LUCY recently presented to the Paris Photographic Society several paper positives obtained with various colours by means of chemical reactions in the fixing baths. He accompanied them with the following communication:—

"I do not pretend to make a *colouring after nature*, such as I hope we shall some day obtain direct upon a sensitized film. I leave the search for this to inquirers more competent than myself to carry them to a successful issue. My aim is quite different, and may be briefly stated as follows:—

"Professional photographers know how difficult it is to satisfy the public, and especially ladies: many of whom, dissatisfied with a simple black and white photograph, insist upon having them coloured.

"But the painter's colour, however light and well-managed it may be, very often conceals the photographic picture, and even causes the resemblance to disappear sometimes. I seek to remove this inconvenience by producing, through chemical means and the aid of different *colourless* salts, an intimate colouring, directly incorporated with the paper or the film of albumen, and which, consequently, allows the photographic picture to appear in its original integrity.

"The colours produced are the result of the combination of the salt employed with the chloride of silver of the paper. Although I have as yet operated only with a very limited number of salts relatively to an enormous number of salts known. I have been able to remark, as may be easily understood, that the alkaline and metallic *chlorides* have always yielded better results than other salts.

"I employ in preference the chlorides of sodium, potassium, calcium, gold, mercury, cobalt, iron, tin, &c.

"Among the other salts, acetate of lead, and cyanide of potassium have yielded very good results.

"My usual mode of operating is as follows:—When the proof is printed, with the aid of a pencil I place on that portion of the proof I desire to colour a very weak and colourless solution of the salt which will give me the wished for hue, and I leave it to dry in the dark; then the proof is placed in the toning bath with the others.

"This supplementary work, which consists in moistening this or that part of the proof, presents no difficulty and is performed very rapidly. I have had to prepare in this

manner two hundred cards a day, and the work was performed in less than an hour by a girl of fourteen.

"The blue colour I obtain with the pink chloride of cobalt rapidly disappears in cold, damp weather, but if the proof be slightly warmed the colour re-appears. I may also state that for toning I employ a mixture of 1 gramme of gold and 8 litres of water (15 grains of gold to 14 pints of water)."

—*Bulletin de la Société de la Photographie Française.*

ON A NEW METHOD OF MEASURING THE CHEMICAL ACTION OF THE SUN'S RAYS.

BY DR. T. L. PHIPSON, F.C.S. LONDON, &c.*

THE exact determination of the chemical action of the sun's rays is an important and interesting question which concerns especially physiology and photography, as well as agriculture, &c. Quite recently I have been fortunate enough to discover a means of measuring this action each successive day with the greatest accuracy, and have reduced this determination to a single chemical analysis by the volumetric method.

Many attempts, more or less successful, have been made to solve this problem. Some years ago, Dr. Draper, of New York, used for this purpose a mixture of hydrogen and chlorine, and observed the amount of absorption each day when this gaseous mixture was exposed to diffuse daylight. This method doubtless gives accurate results, but it is not easy, and requires a special apparatus. M. Niepce de St. Victor attempted the same thing in 1858, by means of a solution of nitrate of uranium and oxalic acid. This mixture exposed to the sunlight evolves a gas, the volume of which may be measured; but no experiments have been instituted to test the accuracy of this method. I have myself experimented with a mixture of iodide of silver and starch, but am not quite satisfied with the results. More recently Professor Roscoe has devised an ingenious apparatus—a sort of photographic pendulum—but the basis of the observation consisting in the darkening of a photographic paper (however carefully prepared) is not altogether satisfactory in a scientific point of view. I happened lately to notice that a solution of sulphate of molybdc acid (that is, a solution of molybdc acid in excess of sulphuric acid), standing in my laboratory upon a shelf which is exposed to the sun for about three hours each day, became bluish green in the daytime and colourless again at night. I repeated the experiment several times and found that the saline solution, when exposed to the sun, was reduced, but when withdrawn from its influence it gradually becomes colourless again by oxydation.

No evolution of gas is observed. During the insolation a certain amount of molybdc acid loses one atom of oxygen, which combines with the water and forms oxygenated water. During the night this gives back its oxygen to the molybdc oxide produced. The reaction may be represented thus:—

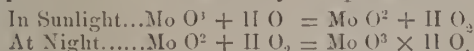

The whole being in presence of an excess of sulphuric acid.

Nothing is easier than to measure with the greatest accuracy the amount of reduction which takes place by the sun's action in a given time. Let it be stated immediately that the change is not influenced by the heat of the sun's rays, for the same solution boiled for some time manifests no change of colour. A weak solution of permanganate of potash destroys the greenish blue tint produced under the influence of the sun's rays, and from the quantity of permanganate solution employed the relative amount of actinism on each successive day may be determined.

The manner in which I prepare the actinometric liquid is as follows:—About 10 grammes of molybdate of ammonia are dissolved in an excess of dilute sulphuric acid. I then introduce metallic zinc until the liquid has become dark blue or

greenish blue; a solution of permanganate is added carefully until the last drop restores the liquid to its primitive colourless state. A provision of this liquid having been made, 20 cubic centimetres are exposed to the direct rays of the sun for one hour each day (from 11 to 12). It is then withdrawn, and the amount of reduction estimated by a very weak solution of permanganate or bichromate of potash of known strength. I prefer a solution made by dissolving 0.25 to 0.50 of a gramme of permanganate in 1 litre of water acidulated with a little sulphuric acid. I make use of a pipette, having a very thin stem graduated into 100 equal divisions. The degree read off on this scale represents for each day the relative amount of actinism, as the thermometer indicates the degrees of heat. I have not yet made a lengthened series of experiments by means of this method, but I find already that the variation of the actinism describes curves which are not only irregular; but sometimes present sudden deflections of great extent similar to what is observed in the barometric curves, to which the former may possibly be related.

P.S.—Since this note was communicated to the British Association I have been seeking a more rapid method, based upon the same principles, but more fitted to the requirements of the photographer. It will be seen that the above means of proceeding is very exact for scientific purposes, and the process is not difficult. We have only to be careful in taking always the same amount of substances to prepare the two test liquors, and to expose for the same length of time. I shall probably be able to replace the molybdc solution by one of oxalate of peroxide of iron, which I showed some time ago to be capable of replacing nitrate of silver in photography.

PHOTO-ELECTRIC ENGRAVING AND OBSERVATIONS UPON SUNDRY PROCESSES OF PHOTOGRAPHIC ENGRAVING.

BY DUNCAN DALLAS.*

I FEEL that an apology is due to the Association for bringing under their notice some results of my process of photo-electric engraving, without, at the same time, describing in full detail the method by which the results have been obtained. Were it not for the more than questionable protection afforded by our patent laws, or were I the possessor of ample means, I should be glad to allow my little rill of applied science to flow unrestrained into the great stream of knowledge, of which your Association is no mean tributary. I regret that at present I must place somewhat of a dam across my little rivulet, and permit but a slender portion to trickles over. I have sacrificed, much in time, money, and position, to the "idea" of engraving photographs. If I have now solved the problem with some degree of success, I am naturally anxious to reap a return for well nigh nine years' exertions, during which the subject has occupied no slight portion of my thoughts and the labour of my hands. At a future day I hope to submit a proposal, which, if agreed to, will enable others to work, and, very possibly, improve my process.

The specimens I now submit must speak for themselves. They have received no aid from the graver. Each plate has passed under the hands of a skilled engraver, but merely for the purpose of careful cleaning. Not a single detail, or half-tone, has been introduced by tool work, nor have the vigorous parts been "doctored" with acid or the roulette. The impressions show honestly the result of the process. I am glad to be in a position to say, that, unless my head or my hands fail me, the system is certain. I can guarantee to produce, in a period varying from one to three weeks, an engraved plate, either from a photograph, or the design of the artist. In this plate, that which constitutes the essence of the original and the despair of hand labour—*fac-simile*, even to minute and almost microscopic detail, should be present. To attain this result, all that I require is a good reversed negative—easily produced by reversing the glass—and a positive print, merely fixed in the hypo, not

* Abstract of a paper prepared for the British Association for the Advancement of Science, at Newcastle. This paper was deemed inadmissible by the Chairman of Section B, as relating to a secret process. It contains, however, matter which will interest our readers.

* Read before the British Association. (See Section B.)

toned. Having but lately emerged from the purely experimental stage—for I still experiment—I have not had time to get up many specimens. Beside the "Banqueting Hall," Kenilworth, (kindly taken for me, on purpose, by Mr. Bedford,) I should have been glad to have placed a reproduction of a good drawing or a highly finished sketch—something done by a Landseer, a Millais, or other eminent artist. I have just commenced a subject of the kind, viz., a sepia drawing, by a well-known artist, who takes an interest in my operations. I do not fear but that I shall reproduce his drawing, touch for touch, preserving the spirit and beauty of the original—a result impossible to hand-engraving.

As all persons now present may not be fully conversant with what has been done in photographic engraving, I would ask permission to say something on the subject. There have been four principal efforts to solve the problem of producing an engraved photograph.

- I. Etching daguerreotype plates.
- II. The bitumen process.
- III. Photography.
- IV. Photogalvanography.

The methods of photolithography and photozincography are not engraving, but more properly transferring processes. From their very nature they can never rival plate-printing. Valuable as they are, undoubtedly, for some purposes, they will in all probability always lack even half-tones, minute detail, and unbroken, clean-edged lines.

Of the four engraving processes above mentioned, the first three are essentially etching methods, while the fourth is an electrolytic process. Those which have given most promise are the bitumen process, photoglyphy, and photogalvanography. The bitumen process and photoglyphy being decidedly etching methods, involve much hand labour. Consequently, it is impossible to ensure fidelity, either in tone or detail. Photoglyphy is the least satisfactory of the two. The etching ground being gelatinous is of a most delicate nature, and the photographic chemical, bichromate of potash mixed with the gelatine has the unfortunate quality of destroying the half-tones and detail the longer the combination is exposed to actinic influence.

Photoglyphy was the name given to a second patent taken out in 1856 by Mr. Fox Talbot, for improvements in his former patent of 1852. There is very little real difference between the two patents. They may therefore be considered as one. That of 1852, entitled Photographic Engraving, is certainly deserving of the merit of striking novelty and great ingenuity. In short, it bears the impress of genius. But, like many other promising and apparently simple processes, it is beset with practical difficulties which have never yet been successfully overcome, but which, from their very nature, operate to produce failure.

While I acknowledge Mr. Talbot's genius, justice compels me to add that his patent has placed him in much the same false position with regard to photo-engraving which his original photographic patent did in reference to the collodion process. It has made him the foe rather than the friend of photographic progress. Indeed, as regards photo-engraving in this country, the present patent laws afford a striking illustration not only of how little they advance science and art, but how greatly they hinder the development. Nine-tenths, if not ninety-nine hundredths of existing patents are either dormant, impracticable, or mere advertising shams. Many patentees either cannot or do not work their patents—nor will they permit others to work them. Such persons are ill entitled to the honour of using the royal arms. Messrs. Cruikshank and Leech might furnish them with a more appropriate heraldic device, say a dog, *latrant*, in a manger, *argent*—supporters, a tortoise and a sloth; the motto, *Noli me tangere*.

It is to be hoped that ere long the present system will receive its death blow. The British Association can do good service. Inventors are unquestionably as much entitled to copyright in the fruits of their brains and hands as the novelist, who, in these halcyon days, obtains fabulous sums as his guerdon. Nay more, the novelist chiefly tickles the fancy. The inventor increases the wealth, power, and happiness of the State. Still no inventor ought to have the power of preventing others from using his invention when willing to pay a reasonable royalty. Even with the existing patent law, it would not only save an immense amount of litigation, but positively advance the arts, were patentees obliged to grant licences at amounts to be

arranged, in case of dispute, by arbitration. Infringements are chiefly occasioned by the selfish exclusiveness of patentees.

I have been led into these remarks in consequence of my experience in my former association with what promised to be the most important advance in photo-engraving. I allude to photogalvanography, a process which owes to me not merely its name, but its reduction to a practical process, and its introduction as such to the public. It is useless to assert, as has been attempted, that this discovery was completely independent of Mr. Talbot's invention. Not only are dates against the assertion by two years, but I am acquainted with facts which leave no doubt that experiments with Mr. Talbot's process led to the discovery.

The essential feature in photogalvanography is the production of a raised image in gelatine from which an intaglio plate has to be produced by the electrolytic process. Now Mr. Fox Talbot discovered this raised image, and it forms the most beautiful feature in his invention. Strangely, he completely overlooked its value, not even including it in the extraordinarily wide claims at the close of his specification. He merely contented himself with admiring its novelty and beauty, while expressing his regret that he was obliged to destroy it in order to effect the only object of his invention, viz., to etch through the image to the plate. When photogalvanography first came under my notice, about nine years ago, I was quite ignorant of Mr. Talbot's labours above mentioned. I was, therefore, much surprised when, early in 1855, I became acquainted, through "Hunt's Photography," 1854 edition, with the details of Mr. Talbot's process, and found points, especially the production of a raised image, so strangely identical with photogalvanography. Being, however, most solemnly assured that the latter process had derived no assistance whatever from Mr. Talbot's discovery, and that the first intelligence of the existence of such a method of engraving was the passage in "Hunt's Photography" which I had just read aloud, I regarded the matter as one of those remarkable coincidences in which two minds arrive independently at analogous discoveries. My surprise, however, gave place to a different feeling when, in 1856, Mr. Talbot first threatened to interfere with the operations of the company I had formed for working the photogalvanographic process. I then made the unwelcome discovery that Mr. Talbot had patented his process, and that long previous to the photogalvanographic patent he had fully described his method in the *Journal of the Photographic Society*, the *Comptes Rendus*, and, I believe, in *La Lumière*.

Photogalvanography like photography, depends on the peculiar action of bichromate of potash with gelatine. In this lies its weakness. It loses half-tone and detail, the more so as it requires a very long exposure. Sometimes the exposure is upwards of six hours, and even then there is no certainty that the right time has been hit. There are, consequently, numerous failures from this one cause alone.

From a series of experiments I conducted with the process, I found that chromic acid was in reality the agent producing the peculiar phenomena. In other words, that with a composition merely of chromic acid and gelatine a raised image with granulation could be produced and subsequently electrolytically. Independently, however, of the loss of half-tone and detail, together with the uncertainty of the exposure—both defects inherent in the process—the granulation was of a peculiar zig-zag and wavy character of great value in the vigorous parts of the picture, but broken or unconnected in the half-tones and fine details. This led to a pretty free employment of the graver and roulette just in the very parts which made hand labour expensive. The process, indeed, was never capable of the high flight which was attempted; and, as I had predicted, it broke down. It was an effort to run, and very fast too, before the bantling had learnt to walk. Where expense was no object, the graver and roulette were a great assistance; but besides lessening the value of the fac-simile, it was a fraud on the public to represent the highly worked up result as photogalvanography. Since the abandonment of the process by the company, other firms have endeavoured in connection with the patentee to render it available. But without expensive assistance from the graver it cannot be used for fine art purposes; and even when highly worked up, the result cannot be said to be perfectly satisfactory. I believe I am well qualified to give an opinion of its true capabilities. It is still a most uncertain process, and on this ground also it is expensive. It gives, however, such a strong grain, that in subjects with broad contrasts, it is valuable. It also renders lines

possessing equal vigour in a very fair manner, but if there is contrast in the lines—very fine and delicate with stronger forms—the defect inherent in the process comes out disagreeably. The longer the light acts, the sooner do the finest lines disappear, and those next in degree become broken. It is the same with dots. Indeed, the disappearance of the finest parts commences with the first action of the light.

It is not with a view to cry up my own process, that I would decry photogalvanography. As I have said, I should have no qualm in working the process, and that without fear of Mr. Talbot's patent, or still less of the photogalvanographic patent itself. But as I can do by my method at a rate as cheap if not cheaper, what pure photogalvanography does at its best, I am merely stating what I am in a position to prove as a fact.

The bitumen process has been chiefly practised in France, but all the specimens produced bear evidence of considerable graver work and finish. As an etching process, there is no question as to its superiority over photoglyphy. It has also the advantage over photogalvanography of a more perfect rendering of the half-tones and detail; but it requires a great amount of hard labour in the intermediate tints and vigorous parts of the subject.

Etching daguerreotypy plates is hardly worthy of mention, as so little has been done with the process. In these days when "impossible" is a hazardous word, I should be sorry to say that it will never prove useful. At present, however, its chances appear very remote.

In the bitumen process, photoglyphy and photogalvanography, the results are obtained from a positive impression. This is in many respects a desirable advantage.

Photo-electric engraving, the specimens of which are now before you, is, as its name imports, an electrotype process. In the photographic part it is as absolutely certain as the collodion process. Its success depends like that process upon the careful dovetailing of three or four main operations, to neglect any of which, or to perform them amiss, is certain failure. The objects I had in view were two-fold:—

I. To obtain a process based on the negative.

II. To produce in the resulting metal-plate the effect of a combination of aqua-tint and stipple.

In the methods which have been adopted (and I believe patented) of building up on the collodion surface there is great risk of injuring the negative. This is a serious defect, involving the taking of another negative—a thing not always practicable. In my process no injury is done to the original negative.

Any one acquainted with engraving is aware that aqua-tint and "chalk," or stippling, produce fine grain, even half-tones, and minute detail. The aqua-tinter employs common resin dissolved in spirits of wine. This poured over his plate, evaporates and leaves numerous globules or bits of resin attached to the surface. The size of these globules depends on the proportion of resin to spirit. When the acid is put on the plate the resin acts as a resist, and a tint is produced in the intermediate parts. If the plate were now electrotyped before the removal of the resin, and a print taken from the electrotype, the resin parts would give a kind of stipple or chalk marks interspersed with tint. It is something similar to this which I have succeeded in imitating, with peculiarities *sui generis*, by photography and the electrotype. I can also, as it were, modify the size of the dots, obtaining them so fine as to carry almost microscopic detail; but, if too fine, there is a risk of deficient depth in the darks. In this, as in all things, there is the happy medium, and this I believe I have secured.

I commence with a varnished negative. This should be reversed, but not necessarily so, for some purposes. From this negative a positive print is taken. This I prefer not toned but merely fixed in the sepia colour by the "hypo." I cover the varnished negative with a material from which I obtain a latent positive. This latent positive I turn by a simple process into a suitable negative. It is with this negative that I subsequently manipulate. I can time the exposure to a nicety, a few seconds over or under making an inappreciable difference. The excess or deficiency must not, however, extend to minutes. If necessary, I can electrotype direct upon my material; but as this might lead to the discovery of part of my process, I prefer to make a different kind of matrix.

I should have been glad to have taken out a patent, with a view to grant licences; but, as the lawyers say, no patent is valid till well litigated. I prefer to run the risk of competition, which, after all, is of more benefit to the arts and to commerce

than such inconsistent monopolies as the present patent laws permit.

In the course of my investigations, during which I may safely say I have performed some thousands of experiments, I believe I have gleaned some interesting, if not important, photographic and chemical facts. It is, I can honestly aver, a source of regret to me that I am not at present able to add my mite of knowledge to the general fund. It is a noble employment for a man possessed of means and leisure to enlist both in the advance of science and art, regardless of thereby increasing his worldly estate. But when a man has spent some of the best years of his life in battling for an object, and sees at length most of his difficulties surmounted at no small cost to his means, to say nothing of his leisure—scanty at the best—it becomes, I think, his paramount duty to "let charity begin at home." The man of means and leisure has received freely—freely let him give. The other must protect himself as best he can, for the law affords him no safeguard against men who, perhaps, never gave ten minutes' thought to search out and apply scientific facts. On the contrary, the law affords such persons every facility for sucking the brains of those who think and work. These considerations must be my excuse for my present reticence. It is also no idle assertion when I state that had I not taken up as earnestly as I have the "idea" of engraving photographs, I should be some thousands of pounds in pocket.

In concluding this paper, which, I fear, has been too long, I would observe that in my process the perfection of the result depends essentially upon the perfection of the original—the more highly finished the latter, the better adapted to my purpose. There is also another important advantage. It is not very much more expensive to work from a good original than from a bad, or inferior one. Though cheaper than second, or even third-rate hand-engraving of a similar class, it is principally as compared with the better styles of engraving that the great cheapness of the process becomes apparent. The saving varies from 25 per cent. to 50 per cent., and upwards. When desirable, special engraved effects can be introduced without injury to fidelity of detail. They would be chiefly of an artistic character—especially in the play of light and shade, or improvement in prints, in which even the best of photographs require attention. For example, in the Kenilworth subject before you, a sky might be introduced, and the foliage in the trees on the right, and other blurred parts, might be made out more clearly. My plates thus afford the artist engraver a valuable basis on which to work; and not only is a great part of his labour and skill anticipated, but he can be outdone by Nature's own touches and effects, or by the brush and pencil of the painter rendered in *fac-simile*.

I beg to thank you for the kindness with which you have listened to me on the present occasion.

British Association for the Advancement of Science.

REPORT OF THE KEW COMMITTEE.

The great importance of photography as a scientific registrar receives annual illustration in the report presented by the Kew Committee, of which we append an abstract.

It commenced by recording the fact that, under the superintendence of the committee, a set of self-recording magnetographs had been constructed for the Lisbon Observatory. These instruments had arrived at their destination, and since July 1st had been in continuous operation, copies of their tracings from July 11th to 16th having been received, during which period a magnetic disturbance had occurred simultaneously at Lisbon and Kew. These tracings, with the corresponding Kew curves, are exhibited to the Association.

The committee have likewise been requested to superintend the construction of a set of self-recording magnetographs for Professor Kupffer, of the St. Petersburg Central Observatory. These were constructed as before, the magnetographs by Adie, and the tabulating instrument by Gibson; and after having been verified at Kew they were despatched to St. Petersburg. Professor Kupffer desired also a differential vertical force magnetometer for Pekin, which has likewise been constructed by Adie, and verified at Kew; it remains in readiness to be forwarded by the first suitable opportunity to its destination. In addition to

these instruments, Professor Kupffer is obtaining from Adie a barograph and a self-registering anemometer, both of the Kew pattern. Professor Kupffer proposes visiting Kew in October, for the purpose of acquainting himself with the mode of working the instruments adopted there.

Mr. CHAMBERS has communicated to the Royal Society a paper "On the Nature of the Sun's Magnetic Action upon the Earth," in which it is argued that, in causing the daily variation, the sun does not act as a magnet.

The CHAIRMAN has procured a spectroscope affording very great angular separation, which remains at Kew; and he has also ordered a heliostat from Paris. By those means it is hoped that the minutie of the solar spectrum may soon be examined with great facility.

The solar spots are now regularly observed at Kew, after the method of Dr. Schwabe, of Dessau, who has been communicated with, and will be written to from time to time, in order to ensure that both observers pursue exactly the same method of observation. It will be remembered that in the report of the committee at the Cambridge meeting it was stated that Mr. De la Rue had taken 177 photographs of the sun, and that the number of available days from February 7th to September 12, 1862, was 124. The Kew heliograph was worked at Cranford up to February 7, 1863, and photographs were procured on forty-two other days between September 12, 1862, and February 7, 1863, making 166 working days in the whole year. The series of negatives are now in course of measurement and reduction by Dr. Von Bosc; the micrometer employed is the same as that constructed for, and used in, the measurements of the eclipse-pictures obtained in Spain in 1860, a detailed description of which instrument is given in Mr. De la Rue's paper in the *Phil. Trans.* vol. clii., pp. 373 to 380. Of the 1862-1863 series, the measurements are finished up to the end of June, and the reductions to the end of April, 1862; both will be completed at the end of this year. In February of the present year the heliograph was removed from Cranford to the Kew observatory, and erected again in the dome. A new and commodious photographic room has been built on the roof of the observatory, close to the dome, and has been fitted up with the requirements necessary for the successful prosecution of astronomical photography. The expense of this room has been defrayed out of the sum of £100 granted for that object at the Cambridge meeting. The actual sum expended up to the present time amounts to £89, leaving a balance of £11, which will cover the outlay for a few pieces of apparatus which are still required. Between February 7th and May of the present year pictures of the sun were occasionally procured at Kew; but the heliograph could not be fairly got to work until the completion of the photographic room and the final adjustment of the instrument itself. From the 1st of May to the present time the heliograph has been continuously worked by a qualified assistant under the immediate supervision of Mr. Beekley. Two photographs are taken on every working day, one to the east, and the other to the west of the meridian, when atmospheric conditions permit of this being done. From May 1st to August 14th inclusive, are been fifty-four working days. Four positive copies are made regularly from each negative, one of which it is proposed to retain at Kew, and it is in contemplation to distribute the others. Mr. Stewart, after an inspection of all the sun pictures obtained by the Kew heliograph, is inclined to think that the behaviour of solar spots with respect to increase and diminution has reference to ecliptical longitudes, and is possibly connected with a position of the nearer planets: but it will require a longer series of pictures to determine this than that which has yet been obtained. The heliograph constructed by Mr. Dallmeyer for Wilna, under Mr. De la Rue's superintendence, has been completed, and will shortly be sent to Russia, together with a micrometer and protractor constructed by Messrs. Troughton and Simms, which will be employed in the measurement and reduction of the sun-pictures. Of the £150 granted by the Association in 1861 for the purpose of obtaining a series of photographic pictures of the solar surface, a sum of £137 3s. has been expended from February, 1862, to February, 1863, and the balance, £12 17s. has been returned to the Association. In 1860 a sum of £90 was voted for an additional photographic assistant, of which £50 was received and expended in that year. The balance, £40, was again granted in 1861, out of which £20 2s. 10d. have been expended. The working of the Kew photo-heliograph during the year commencing in February, 1863, will be defrayed out of a grant placed in the hands of Mr. De la Rue by the Royal Society for that purpose.

ON SOME PHENOMENA PRODUCED BY THE REFRACTIVE POWER OF THE EYE.

BY A. CLAUDET.

The object of the paper was to explain several effects of the refraction through the eye, one of which is, that objects situated a little behind us, are seen as if they were on a straight line from right to left. Another, that the pictures of external objects which are represented on the retina, are included in an angle much larger than one-half of the sphere at the centre of which the observer is placed; from this point of view a single glance encompasses a vast and splendid panorama extending to an angle of 200°. This is the result of the common law of refraction. All the rays of light passing through the cornea to the crystalline lens are more and more refracted in proportion to the angle at which they strike the spherical surface of the cornea. Consequently, the only objects which are seen in their true position are those entering the eye in the direction of the optic axis. By this refraction the rays which enter the eye at an angle of 90°, are bent at 10°, and appear to come from an angle of 80°. This phenomenon produces a very curious illusion. When we are lighted by the sun, the moon, or any other light, if we endeavour to place ourselves in a line with the light and the shadow of our body, we are surprised to find that the light and the shadow seem not to be connected at all, and that, instead of being in a line, they appear bent to an angle of 160° instead of 180°, so that we see both the light and the shadow a little before us, where they are not expected to be. The eye refracts the line formed by the ray of light, and the shadow and the effect is like that of the stick, one-half of which being immersed in water, appears crooked or bent into an angle at the point of immersion. This enlargement of the field of vision to an angle of 200°, is one of those innumerable and wonderful resources of Nature by which the beauty of the effect is increased. Our attention is called to the various parts of the panorama which appear in any way a desirable point of observation, and we are warned of any danger from objects coming to us in the most oblique direction. These advantages are particularly felt in our crowded towns, where we are obliged to be constantly on the look-out for all that is passing around us.

INVISIBILITY OF LIGHT.

The Abbe Moigno exhibited and explained the "Tenebroscope" invented by M. Soleil to illustrate the invisibility of light. The Abbe humorously observed that this term was somewhat of an Irishism, but nevertheless it was a fact that light is quite invisible, for celestial space was perfectly dark until the appearance of a celestial body, and then it became perfectly illuminated. The instrument for illustrating this consists of a long tube, closed at one end, but with a short opening in the centre, in which is introduced a white ivory ball, capable of being placed and withdrawn at pleasure. The object of the instrument is to illustrate the principle that light is only the action of a luminiferous medium by which bodies are made visible; and that neither the light itself or the medium is visible. On looking through the glass with the ball withdrawn, no light is seen, but immediately on the ball being replaced, it is distinctly seen at the end of the tube. The president said this principle was first laid down by Aristotle, that light is the action of a luminiferous medium, whereby bodies are made visible. Neither light nor luminiferous medium are visible, but require the introduction of a body to make the light manifest.*

ACTINIC CONDITIONS AT A HIGH ELEVATION.

Professor C. PIAZZI SMYTH called attention to the increased dioptric and actinic quality of the atmosphere at a high elevation as illustrated by his photographs on Tenerife. If, he said, a photographic landscape were taken at the sea level, and if in the view there were included some distant hills, it would invariably be found that those hills would be represented only by the faintest aerial impression of a perfectly uniform tint; and though the examination were pursued with a good compound microscope, nothing further would be ascertained—no matter if the sun were shining brightly at the time the photograph was taken, and the hill itself was marked by well-defined irregularities, not one of them appeared in the picture.

* We have been amused occasionally by observing in articles in some of the journals on "lighting," the statement that light was opaque. It will be seen at once that if light be invisible it cannot be opaque.

But when a similar view was taken at an elevation of from 5000 to 10,000 feet a distant hill, forming part of the mountain range, was perceived with all its details, at a distance of four miles or five miles and a half from the camera; and when a good microscope was applied to the picture at once, they found the same projecting mountain, and saw what not merely the ridges and hills, but the valleys, rivers and lakes upon the distant hill sides. At a height of two miles above the sea level the actinic rays by which the photograph was produced experienced less disturbance at the long distance than when at the sea level they had to penetrate only 200 or 300 feet of the denser atmosphere. He has inclined to believe that one great agent in producing this remarkable degree of definition of minute distant features was the steady, uniform current and more equal temperature prevailing at the greater elevation. The effect of this might also be ascribed to the improved brilliancy of the stars when seen from a considerable height. There were few nights in which, at the sea level, the highest power of the astronomical telescope could be employed; but the case was altogether different when the observations were taken at great elevations.

The repeated tracing of these remarks was to indicate the importance of establishing the observatory at a great height above the sea level.

Mr. GLAISHER made some extraordinary observations. His own experience was that were an observatory placed at a high elevation, more discoveries might be made in one year than would be made in a hundred years by observatories placed on a low elevation. He had then earnestly wished that an observatory could be placed—perhaps, if possible, but even first of all—at some high elevation. He made the Association were much indebted to Professor Piazzzi Smyth for the noble manner in which he had made his observations on the Peak of Teneriffe, and submitted them at different times to the meeting. (Applause.) He trusted that, before long, some of the other eminent astronomers might be induced to ascend to the same elevation and prosecute important investigations. (Applause.)

The President, in moving a vote of thanks to Professor Smyth for his important communication, also expressed the hope that, before long, another expedition of scientific men would be completed to the Peak of Teneriffe.

The photographs exhibited were from enlargements of small negatives, some being enlargements upwards of five hundred and others upwards of one thousand. They consisted of illustrations to the recently issued Astronomical Observations made at the Royal Observatory, Edinburgh, edited by Professor G. P. Smyth. They were views of a mountain, 4½ miles distant, clearly taken at a height above the sea level of 10,700 feet, the object being well made out. One print was from a negative taken at the sea level with the same camera lens, camera, &c., and so forth under the same conditions, except altitude. This was thirty times as dirty as the other. One of the prints was a photograph by Mr. Fox Talbot, which presented many good qualities.

PHOTOLITHOGRAPHY, &c.

The Allen Medal exhibited a section B some specimens of photolithography, which presented a certain amount of brilliancy. The process was invented by M. Mangelier; but in what its superiority consists the Allen did not make clear.

Some other papers, interesting to photographers, were given in their entirety on another page. The sessions of the Association will be held next year at Bath.

Correspondence.

FORMIC ACID AN ACCELERATOR.

SIR.—Being a constant reader of your valuable periodical, I could not help noticing the discrepant opinion as to the accelerating effect of formic acid in the negative developer: desirous of judging for myself, I have commenced a series of experiments. As yet I have only tried it in combination with pyrogallie acid and with bromo-iodized collodion, and from these experiments have arrived at the following conclusions, namely, that formic acid added to pyrogallie in the developer as recommended by M. Claude,

is quite as powerful as the ordinary iron developer, and moreover that the nitrate both does not require to be added, the quantity of nitric acid usually referred to be added. The day on which I made these comparative experiments was one very miserable for successful photography, the light being dull, and the sky covered with dark masses of clouds. The lens I used was the front one of a French half-plate portrait combination reversed, forming a 14-inch view lens, the stop I used being 2 inch. The bath was an old one that had been neutralized and covered the day before; on mixing I added 7 drops of a dilute solution of nitric acid (1 part acid to 7 water) to each pint which, therefore, contained 7 drops of pure acid. The collodion I used was rather a complicated composition, and is one that I generally employ for photographing anatomical preparations, &c. It is composed of equal parts of Mawson's collodion for iron development, Rank's bromo-iodized and some of my own made, iodized after E. Glaisher's formula for iron-uranous collodion. You will see by the above that my collodion contains a considerable proportion of bromid salts.

Having coated and sensitized a plate I exposed it for fifteen seconds with the above-mentioned stop and lens. On applying the formic acid developer, an image started out with marvellous rapidity. On inspection, the negative proved to be under-exposed. I prepared another plate, and gave it seven more seconds. The result was a fine, clear well-defined negative with deep shadows; perhaps if anything, very slightly over-exposed. I enclose a print from it for you to judge from. The developer I made as follows:—

Pyrogallie acid	20 grains
Formic acid	4 drachms
Alcohol	4 "
Water	10 ounces.

Dissolve.

The formic acid I obtained from a chemist in Southampton (Mr. Downman).

I next prepared a plate with the same collodion and bath, and exposed it precisely the same time, but developed with—

Sulphate of iron	20 grains
Acetic acid	15 drachms
Alcohol	15 "
Water	1 ounce.

The result was a negative full of detail, but far surpassed with the preceding one. I enclose a print for you to compare with the other one. I think from these experiments you will agree with me that formic acid is an accelerator, and that to a considerable degree as a plate prepared with bromo-iodized collodion, and developed with the old pyrogallie acid and acetic acid developer, would have required at least three times the exposure as when developed with iron.

I intend, during the ensuing week, instituting a series of experiments to prove whether the formic acid developer will prove successful with plain iodized collodion, and other conditions of bath; also in combination with iron.

I enclose a print from a tennis and tennis negative of the main wing and centre block of the Royal Victoria Hospital. The building forms a rather bad subject to photograph, being built of unexcelsior red bricks and white limestone. I had Mawson's collodion for iron development, with the addition of 1 grain of bromide of cadmium to each ounce, make a capital collodion for this process.

Hoping you will excuse me for consuming so much of your valuable time, I have the honour to be, Sir, your most obedient servant.

W. A. Moss, Sergeant Army Hospital Corps.

Royal Victoria Hospital, Netley, September 10, 1863.

[The prints enclosed by our correspondent are very good, and fully bear out his position.—P.]

Photographic Notes and Queries.

IMAGE ON THE RETINA OF A DEAD EYE.

DEAR SIR,—Seeing in our local paper the other day an account of a peculiar photographic incident stated of having been going round of the French papers, I found it to be Mr. W. A. Warner's experiment of photographing the eye of a calf shortly after death, reproducing on the photographic plate a representation of the pavement, &c., of the slaughter house. I remember a brief account of this appearing in the News a considerable time ago.

My object in writing is to ask Mr. Warner (who by the bye is always willing to give his brother photographers the benefit of his experience), to give a few further particulars respecting this very singular phenomenon, and also if he has made any further experiments, as I am sure it will be a subject of interest to photography.—I am, sir, yours truly,

ENQUIRER.

Leeds, September 2, 1863.

[We know nothing personally on this subject beyond the reports often alluded to; possibly Mr. Warner may have further evidence on the subject. We have been generally disposed to regard such stories in the light of *canards*; but whilst we never receive things as truths except on satisfactory evidence, we do not reject well authenticated statements as falsehoods, simply because they appear improbable. Many things appear improbable simply because they belong to a range of facts which have not come within common experience.—ED.]

Talk in the Studio.

PHOTOGENIC PROPERTIES OF THALLIUM.—Mr. Crookes, in his recent paper before the British Association, remarks:—Several thallium salts are sensitive to light. The protochloride and double phosphate of thallium and ammonia are especially so.

LIME TONING.—Our correspondent, "A Photographer's Assistant," has recently sent us prints from various batches of paper, some of which were very prone to mealiness. All the prints are very brilliant, of a rich, warm, black tint, and quite free from mealiness. They are all toned by modifications of the lime bath, made to suit the existing conditions.

PHOTOGRAPHS IN PRINTING INK.—Mr. Pouncy informs us that he finds mineral naphtha, which is less than half the present price of turpentine, may be used in place of the latter in developing or removing the superfluous pigment from his prints. We had already tried it and found it to answer; but with one slight drawback. When naphtha is used the print is rapidly cleared, but the black pigment is apt to be precipitated in a powdery form, some of the particles clinging with obstinacy to the whites of the picture. With care or further practice this difficulty would probably be got over. Mr. Sutton has just issued a pamphlet on the subject which we hope to review in our next.

To Correspondents.

T. C. F.—The reply to one of your questions was omitted in our last. There is no difficulty in becoming a member of the Photographic Society. You require to be proposed by a member; we will have pleasure in doing this for you. The subscription is a guinea a year, and a guinea entrance fee. Any further particulars you can learn of the Secretary, Dr. Diamond, Twickenham House, Twickenham.

WALTER H. DAVIES.—The most fully detailed description of the process of photolithography was that of Mr. Osborne, given in our pages twelve months ago. In the process of M. Morvan, regarding which you inquire, the proportions are as follows:—Albumein 6 parts, water 6 parts, bichromate of ammonia 1 part; apply with a soft brush. A transparent positive on glass must be used, as it is the parts which have been protected from light which form the blacks of the subsequent picture. After the stone has been treated with soap, an ordinary lithographic roller and ink are used, we presume.

HOW.—We have not any exact information regarding the existing Architectural Photographic Association. The old one was dissolved some time ago. We have seen recent allusions to the existence of another, but no notice of its origin or character. We believe it is in some way connected with the Architectural Association, and has its local habitation in Conduit Street, Regent Street. 2. We cannot explain the cause of the spot referred to without knowing further particulars. We have seen such spots arise from various causes, and it may possibly be a defect in the paper. It is impossible to form a very definite idea of the quality of a portrait which has the greater portion of the face carefully cut away; but it seems to be pretty good. 3. The print of Lacock Abbey, from a wax-paper negative, is too deeply printed; but is otherwise satisfactory. 4. A pale over-donc

tannin negative may be intensified by various methods. Perhaps the most suitable is as follows:—Make a solution of 1 grain of iodine and 2 grains of iodide of potassium in 1 ounce of water. Apply this to the plate for a few minutes, in daylight, and wash. Then take a 3-grain pyrogallie acid solution with 2 grains of citric acid, and add a little of a fresh silver solution. This will readily give you intensity.

11. FAONSHAM.—The double sulphate of iron and ammonia is of a very pale green tint. It keeps in crystals perfectly, and pretty well in solution. 2. An iron developer which has been long kept loses some of its energy, and develops slowly but with great clearness. Sometimes, when very old, it requires the plate to have been longer exposed than a fresh solution. 3. An iron solution with its proper proportion of acetic acid, kept in a well stoppered bottle, will keep for months without much injury. We cannot tell you how long sweetwort will keep; but it is a very unstable preparation and would probably rapidly change, especially in warm weather. 4. The use of a chloride of calcium box is to keep excited paper from discolouring when prepared some weeks beforehand. The chloride of calcium effects this by keeping the atmosphere in the box very dry in virtue of its own affinity for moisture. 5. We have seen some prints produced by development which could not be surpassed for beauty; but they generally lack the brilliancy and transparency of prints obtained direct. 6. The numbers of the PHOTOGRAPHIC NEWS for one year form a volume. If you send direct to us we will endeavour to get you an ALMASAC.

NO SIGNATURE.—A correspondent who does not append a signature to his letter, but encloses two cards. Are the spots regarding which you inquire in the negative or only in the prints? At present we do not see the cause.

1. The chief fault in the unmounted prints is over-exposure of the negative. Give your negatives less exposure, and use more direct light and less diffused light. 2. Two ounces of hyposulphite of soda will fix from a hundred to a hundred and fifty card pictures, but it is wise to keep within the number. The time of immersion will vary from ten minutes to twenty minutes, depending on the thickness of the paper and on temperature. 3. A bath neutralized with ammonia is apt to get out of order and cause fog, as solution of nitrate of ammonia will hold oxide of silver in solution. With care you may, however, use the solution either as a negative or positive bath. 4. If the prints are kept in motion, and the water frequently changed or kept running, about six hours, are sufficient for washing. Some persons prefer to give twice that time. 5. The address of Messrs. Hopkin and Williams is New Cavendish Street.

THE UNKNOWN asks us if there be anything in photography to influence the minds of its votaries for evil. He says, "I know scores of photographers, all of whom have shocking tempers, are frightfully proud, and seem to think none such good artists as themselves." He also sends us some lines which he thinks especially suitable for the perusal of photographers generally. We really cannot agree with him. Photography is an art which, especially when practised professionally, makes great demands upon the patience of its students, and often tries the temper in various ways. Notwithstanding this, we believe it numbers amongst its disciples some of the best fellows in the world—men patient and unwearied in the pursuit of excellence in their all-absorbing art, and genial and estimable in social life. A cantankerous photographer is an exception to the general character.

AN AMATEUR SUBSCRIBER.—We do not quite understand what you mean by both negatives and positives turning yellow when they are varnished. The pure whites of glass positives are often degraded a little by varnishing, especially if you use a strong-bodied spirit varnish. The use of "Newman's Colouring Varnish," or the "Alabastrine Varnish," sold by Squire, will obviate this. The nature of the injury to the negatives produced by varnishing, we do not quite understand.

R. G.—Collodion which has acquired colour from age is favourable to intensity. When the colour is communicated by adding free iodide, the only way in which intensity is effected is by the plate permitting longer development without fogging, and thus getting more intensity. Otherwise free iodide does not, *per se*, affect intensity. Nor does it with a bromo-iodized collodion cause insensitiveness. Its chief use is to aid in preserving clean shadows.

HYPO TONING.—Some samples of paper are very prone to lose much of their tone in the hypo bath; in which case it is desirable to tone much deeper than is required and tone slowly. Nevertheless, the tone of the print you enclose is in our estimation very pleasant. We prefer warm tones for landscapes and similar subjects.

AN AMATEUR.—Remove the lens from its cell and blacken the edges; that will probably remove the spot of light, which probably proceeds from reflection. 2. Mawson's collodion is bromo-iodized.

M. A.—The examples of your sensitive film reached us so broken and abraded that we could not make a satisfactory examination. We have not met with anything of the kind, nor can we account for it. Is your tannin solution carefully filtered? And are your plates sufficiently washed? We will give the matter some further attention.

T. W. T.—We will forward the question to Colonel Stuart Wortley, direct. BROWN STAIN.—A correspondent, whose letter is at this moment mislaid, asks the cause of the brownish yellow stain in the face of an old lady. It appears to be the result of under-fixation, the hypo bath probably being old, and the print not well immersed, or, perhaps, stuck to another.

MA. WARNEA, of Ross, begs us to state that he is in receipt of a 5 by 4 negative, "A Gentleman sitting by a table," without any directions as to what is to be done with it. Any gentleman having forwarded the same will oblige by writing him thereon.

Several Correspondents in our next.

Photographs Registered during the Past Week.

- MR. JOHN BEATTIE, Clifton, Bristol,
Seven Photographs of the Right Rev. the Lord Bishop of Oxford.
- MR. JAMES LAING, Castle Street, Shrewsbury,
Photograph—View of "Moreton Corbett Ruins"
- MR. PAVCE JONES, Hope Street, Wrexham, Wales,
Photograph of Mr. W. Larsing.
- MESSRS. AZULAY AND CO., 7, Gloucester Street, Commercial Road East,
Photograph of Gates of New College and Hospital, Lower Norwood.
- Photograph of New College and Hospital Building, Lower Norwood.

THE PHOTOGRAPHIC NEWS.



Vol. VII. No. 263. — September 18, 1863.

CONTENTS.

	PAGE		PAGE
New and Simple Method of Gold Toning.....	445	National Photographic Portrait Museum.....	452
History of Carbon Printing.....	446	Photographic Pictures and Illustrations.....	452
Jottings from the Note-Book of a "Photographer's Assistant."—		Correspondence—Formic Acid in the Developer—Relative Ex-	
No. I.....	447	posures for Various Processes.....	454
Photographic Chemicals.....	448	Photographic Notes and Queries—Queries on Gold Toning—	
Photolithography.—No. III.....	449	Cheap Glass Rooms—Lime Toning—Insensible Spots, &c.....	455
The Manufacture of Photographic Collodion. By W. L. Noverre.....	450	Talk in the Studio.....	455
The Analogy of the Eye to an Optical Instrument. By J. Z.		To Correspondents.....	456
Laurence, F.R.C.S., M.B.....	451	Photographs Registered during the past Week.....	456

NEW AND SIMPLE METHOD OF GOLD TONING.

WE have recently been experimenting with a method of toning which possesses the merit of great simplicity, and does not require the solution to be prepared some time in advance. The prints, after being well washed, are immersed for five minutes in a solution containing from five to ten grains of carbonate of soda in an ounce of water. They are then carefully drained, and without further washing immersed in a solution of chloride of gold, one grain in about five ounces of water, without any other addition. The prints retain sufficient of the alkaline solution to preserve them from the action of any trace of free acid, and also to set up the necessary decomposition to produce toning action. The toning also seems to proceed very gradually, and without the slightest tendency to mealiness, or to any excessive bleaching.

We are so well satisfied with the acetate bath for warm tones, and with the lime bath for black tones, that we do not bring this forward with any view to supersede these methods; but as a simple and convenient method of proceeding, either when mealiness is troublesome, or when a bath requiring time for its preparation is not ready.

HISTORY OF CARBON PRINTING.*

MR. SUTTON has written an interesting little work on Mr. Pouncy's process of producing photographs in printing ink, in which he glances at the history of carbon printing generally, and more especially of what he terms direct carbon processes, or those methods by which a print is produced on paper prepared with carbon, combined with some sensitive material, of which Mr. Pouncy's patent process is the latest and most perfect example.

The work is written with that simplicity and vigour of style with which Mr. Sutton's readers are familiar; but there is also something of the tone of the advocate who knows no other excellence than that the cause of which he is pleading. For instance, in the Introduction to his work, the importance of a carbon process is enforced by an allusion to the instability of photographs produced by other methods. The instability of photographs has been an admitted reproach, but not the implied universality of that instability. Mr. Sutton says:

It is the reproach of all photographs produced by the common methods that they fade. Beautiful as they are in colour and effect, want of permanency is the unfortunate stigma which attaches to them; and if the term permanent is ever applied to any class of common photographs in contradistinction to another, the term must be understood as employed in a very limited and relative sense, for no one has a right to affirm with confidence that either a silver print, a Daguerreotype, or collodion positive or negative, however carefully manipulated or preserved, will absolutely remain unchanged during even the short space of a

dozen years. Some processes may yield proofs less liable to change than others, but none of those which are commonly employed by photographers yield results which are at all comparable in permanency to the works of the painter or engraver. Had pictures and prints been as perishable as photographs, what would have become of the arts of painting and engraving? Or had impressions pulled in the printing press been as liable to fade as photographic positive prints, where would civilization have been at this moment?

Now, if we are not mistaken, Mr. Sutton has frequently reiterated that he has never known a developed print to fade. In a recent conversation with Dr. Diamond, on calotype negatives, he stated that he had never known one to fade, and we need scarcely add that there is no higher authority on that subject. We have never known a well kept collodion negative, collodion positive, or daguerreotype to fade. Indeed, we have never known a daguerreotype which had been properly gilded to fade at all. By exposure to damp or foul air, we have known them to become tarnished, &c., but we have never met with one of which we could not, in a few minutes, restore the pristine beauty, by the simple application of a solution of cyanide of potassium, and we should feel no hesitation whatever in affirming, with all confidence, that a carefully produced and fairly protected daguerreotype or collodion positive would remain unchanged very much longer than a dozen years. It is upon ordinary prints on paper that the chief stigma has rested. These, if produced with proper care and observance of all known conditions, will, we doubt not, remain unchanged for more than a dozen years; but, nevertheless, it is an unfortunate fact that owing to the combined effects of ignorance and carelessness in the past, few persons would like to stake their reputation on the affirmation that any given print would remain unchanged for, perhaps, half of a dozen years.

Hence the unquestionable importance of a carbon printing process as a means of giving to photographs absolute and unquestionable permanency. "But," as Mr. Sutton pertinently remarks, "at the same time it must be granted that unless this problem can be solved in such a way as to sacrifice none of the beauty of the common photographs it will be comparatively valueless, because permanency will never be considered an equivalent for the absence of beauty and other good qualities." Mr. Pouncy's process is a very great advance in this direction, and we believe, when well worked, will prove still more so. At present we cannot say that we have seen such perfect prints produced by it as we have seen by M. Fargier. But whilst the process of the latter gentleman is, we believe, so beset with difficulties that it is very unlikely to become a practicable commercial process, Mr. Pouncy's is elegant and simple, and promises, in skilled hands, to give better results than have yet been produced by any carbon process.

Mr. Sutton emphasizes the idea which we suggested in our article on the subject in the PHOTOGRAPHIC NEWS for July 31st, which contained the first published description of

* "Photography in Printing Ink." By Thomas Sutton, B.A. London: Sampson Low, Son, and Co.

the process in detail. We then suggested that the obtaining of half-tone was probably due to the action of light reaching that portion of the sensitive compound which was in contact with the paper first, the principle being similar to that upon which M. Fargier obtained half-tone in his carbon prints. Mr. Sutton says:—

The principle of getting half-tone consists in printing *through* the paper, because then none of the material which is acted on by light is subsequently washed off, and the intensity of blackness will depend upon the exact power of the negative to stop the light in its different parts. The paper is so thin, and its surface so fine, that printing through it does not injure the definition. And lastly, the black stuff is so perfectly soluble in turpentine, where the light has *not* acted, that the *whole* of it is dissolved from those parts, leaving them as pure and stainless as if nothing had been applied to the paper.

We ascertain further from the pamphlet before us a fact which had previously escaped attention, namely, that this suggestion for the production of half-tone was not originally due to M. Fargier, but to one of our own countrymen, Mr. Blair, of Perth. M. Fargier's process was patented in the latter part of 1860, whilst Mr. Blair's letter, containing the suggestion, was published in the *Photographic Notes*, in January, 1859. As we conceive this to be a very important point in the improvement of carbon printing, we think it important to give to Mr. Blair the definite recognition of his original suggestion.

We now extract Mr. Sutton's brief *résumé* of the history of carbon printing.

Before proceeding to the history of carbon printing it is necessary to define clearly what is included by the term, because, unless a precise definition is now given, it might be supposed to include processes of a different nature, but which lead to a somewhat similar result, when it is only required to obtain copies in which the dark parts consist of lines or dots.

By carbon printing, in its strict sense, is meant the art of obtaining a positive photographic copy from a negative, at one operation, by the direct action of light, the carbon being mixed with the sensitive material that is applied to the paper, and then fixed to the paper by the action of light. There are other processes in which an image is first obtained upon a photographic tablet by the action of light upon some chemical substance which does not contain the carbon, and the carbon is afterwards applied to the image and made to adhere to the dark parts of it; but those processes must not be confounded with that which is more strictly defined as carbon printing, and which is the only one that will at present render half-tone. To prevent confusion, the latter might be called direct carbon printing, and the former applied carbon printing. The various photolithographic processes, and probably also the prototype of M. Joubert, come under the latter denomination, and no allusion need be made to them in this work, because they are based upon a different principle from that which is described here, and will only yield successful impressions in lines, or dots, and not in half-tone.

Having thus defined carbon printing, the history of that art will evidently not include any account of the labours of those who have employed solely the applied processes, for purposes of obtaining copies of objects in lines or dots. We are simply concerned now with the history of an art by which it has been found possible to reproduce successfully in carbon all the delicate gradations of tone which exist in a good negative photograph.

Of course the art of carbon printing includes the process of printing on the same principle in various coloured pigments, since these merely take the place of carbon in the operation.

The first suggestion of the idea of employing colouring matter in a state of mixture with a sensitive substance, in order to get a coloured positive impression by exposure to light, is due to Mr. Mungo Ponton. That gentleman, in the year 1838, published in the *Edinburgh New Philosophical Journal* the account of a process by which he prepared sensitive positive paper with a mixture of bichromate of potass (the sensitive substance), and sulphate of indigo (the colouring matter), and thus obtained a print in which the lights and shadows exhibit different shades of green.

In the above process, it will be observed that the colouring matter, sulphate of indigo, is not strictly a pigment but a coloured solution.

The next step was not taken until many years afterwards. In 1855, M. Alphonse Louis Poitevin took out a patent in England, bearing date December 13th, in which he vaguely describes a process by which a direct carbon print may be obtained.

The following is an extract from that part of his specification which bears upon this subject:—

I apply various liquids and solid colours upon paper, cloth, glass, and other surfaces, by mixing such colours with a mixture composed of equal parts of a concentrated solution of albumen, fibrine, gum arabic, gelatine, or similar organic substance, and a concentrated solution of bichromate of potass, or of any base which does not precipitate the organic matter of the first solution, and applying this new mixture or combination to the paper, or other fabric or surface.

The photographic impression is produced upon this prepared surface by the action of light passing through a negative photographic picture, or an engraving, or other suitable object, or screen, or in the camera obscura, and it is then washed with a sponge and a large quantity of water. The albumen, or other organic matter, is rendered insoluble at the parts where it has been acted on by the light, and the design is thus produced in the colour which has been employed. Mixtures containing different colours may be applied to different parts of the surface corresponding to different parts of the negative or screen employed to produce the photographic impression. A design in several colours may thus be produced. The proportions of the materials may be varied.

What I claim as new is, the mode of printing upon paper, cloth, glass, or other suitable surfaces, by applying to them a mixture of liquid or solid colours, with the aforesaid chromatised albumen or other organic matter, and exposing to light as hereinbefore mentioned, and afterwards washing away those portions of the mixture which have not been acted upon by the light, as hereinbefore described.

There can be no doubt that the above patent contains the idea of a process of direct carbon-printing; but there is no evidence to show that M. Poitevin ever produced a carbon print by the process described until some years afterwards, when Mr. Pouncy, of Dorchester, had done so, and given an exact formula. It is notorious that a large proportion of the patents granted in this country are for mere ideas, and there is no evidence to show that M. Poitevin's process was anything more than an idea. He never publicly exhibited a carbon print taken by himself prior to the publication of Mr. Pouncy's exact formula, although repeatedly challenged to do so. The idea which he patented was evidently based upon Mr. Mungo Ponton's process, and is but a very slight extension of it. It is needless, however, to say more on the subject, because M. Poitevin's method has now been superseded by one infinitely better, and his patent was allowed to lapse.

The next in the field was M. Testud de Beauregard. He took out a patent in England, bearing date December 12th, 1857, for an invention which consists in producing photographic proofs or pictures by means of carbon or other colouring matter, applied by superposition, to a coating sensitive to the action of light. The following are the particulars gathered from his specification:—

Paper is immersed in or floated upon a warm solution of bichromate of potass or ammonia, mixed with gelatine. It is then dried, and its surface covered with the pigment. The pigment may be rubbed over the dry surface with a pad of leather or other suitable material, or it may be ground very fine with nut oil or other oil, and rubbed over the surface, which is subsequently immersed in a bath of ether, to which a little collodion may be added, or the paper may be immersed in a bath of indian ink, or other pigment, ground up very fine with water and mixed with gelatine, and a little gum or dextrine, and used hot; or rollers, or presses, or other apparatus may be employed to apply the pigment or assist the operation. The paper having been prepared in the dark, is exposed to the action of light and washed in hot water. This dissolves the gelatine which has not been acted on by the light, but does not dissolve that which has been rendered insoluble by the action of light, and which insoluble gelatine retains the pigment, and thus produces the image. Glass or other substances may be substituted for paper. By employing carbon, pigment, or finely-divided gold or silver, photographs or pictures of the greatest permanence and durability may be obtained.

As in the case of M. Poitevin, there is no evidence to show that M. Beauregard ever publicly exhibited a carbon print taken by the above process prior to the publication of Mr. Pouncy's method a few months afterwards.

The history now takes us to the part which I have myself played in this matter. Without knowing anything of what M. Poitevin or M. Beauregard had patented, I published the following leader in my *Photographic Notes* of January 1st, 1858:—

Some experiments in which we were engaged a few weeks ago, lead us to believe in the possibility of printing in carbon, by the following process:—

First.—Dip a sheet of blotting-paper in a mixture of bichromate of potass, albumen, and finely-ground charcoal, or blaken it (in the dark), with indian ink, ground up with a solution of bichromate and gelatine, or albumen.

Next.—Dry the blackened paper, and expose it to light under a negative.

Lastly.—Immerse it in water, which will more or less perfectly remove the black material from those parts where light has *not* acted without disturbing those parts where light has acted, and thereby rendered it insoluble

In this way, a print in black, and a sort of dirty white, may be produced; after which it is probable that immersion in an alkaline solution may clear up the lights sufficiently. This was the direction in which we were experimenting a few weeks ago, when some matters interfered to prevent our carrying the experiments any further.

About two months after the publication of the above article, I received by post, from one of the subscribers to the *Notes*, Mr. John Pouncy, of Dorchester, several prints, which he assured me were veritably printed in carbon, by the direct action of light upon the paper. These prints were clean in the lights and very promising in general effect, although the process was then far from perfect.

Mr. Sutton then proceeds to narrate the details of Mr. Pouncy's first carbon process, of its publication, and the sum of £80 presented to Mr. Pouncy by subscription. He then adds:—

The publication of Mr. Pouncy's process made a great stir among photographers both in France and England; but although it was tried and abandoned by most persons as incomplete, still the possibility of producing a carbon print in this way having been practically demonstrated, several enterprising and intelligent experimentors took it up as the basis of various modifications which have since been largely applied to useful purposes. The names of Asser, Salmon, and Garnier, Joubert, Sir Henry James, Mr. Osborne, M. Fargier, and some others will be familiar to most readers of this work, as the inventors of various modified processes in which carbon forms the material of the photographic reproduction.

We may remark, before proceeding further, that Mr. Sutton omits, in the *résumé* we have quoted, to mention the name of M. Becquerel, who, in 1840, experimented largely with the combinations of bichromates and organic matter. Nor does he do entire justice, we conceive, to M. Poitevin and M. Beauregard, in both of whose processes the elements of carbon processes are very distinctly enounced; whether either of them did or did not ever produce pictures by these processes, we are not in a position to state. But still more unfair than this is it, we conceive, to refer to the processes of Joubert, Asser, Osborne, James, and others, as modifications of Mr. Pouncy's process, seeing that they bear no more relation to it than they do to Poitevin's, propounded years before. M. Poitevin's specification did, indeed, include a system of photolithography, and whether it ever were reduced to practice or not, his was undoubtedly the first published germ of the application of Mungo Ponton's discovery to photolithography. Other experimentalists, amongst whom we may mention our present contributor, Mr. Joseph Lewis, had been working in a similar direction but had not published. The independent discoveries of Asser, Osborne and James respectively of the transfer process, constitute a definite and distinct landmark in the history of this branch of photography. These gentlemen had each profited, doubtless, by the labours and discoveries of those who had preceded them, of Ponton, Becquerel, Talbot, Poitevin, and, possibly, of Mr. Pouncy; but it appears to us as unfair to describe the processes of these gentlemen as merely modifications of Mr. Pouncy's process as it would be to describe his as simply an imitation of M. Poitevin's.

Let us be distinctly understood. We do not wish to deprive Mr. Pouncy of a title of his just reward or credit. We have, very ungrudgingly, and we think heartily, acknowledged the merit of his latest process. We have accorded to him the credit of a hard-working, persevering, and ingenious experimentalist. We did not begrudge him one farthing of the £80 by which his first labours were acknowledged. We hope he will receive still more substantial reward for his more recent efforts. But we deprecate, on his own behalf, as well as on behalf of other photographic inventors and the photographic public at large, undue and over-comprehensive claims on his own behalf, because such claims produce a recoil in the public mind, which will prevent him receiving the full justice which would otherwise be readily accorded. Mr. Sutton is a warm, generous, and enthusiastic advocate, who is, by his enthusiasm, led

to make claims which cannot, we think, be supported, and are scarcely judicious.

The question of Mr. Pouncy's treatment by the Photographic Society is freely handled in the pamphlet, and in a tone far from complimentary to the society. We do not care to discuss the matter now, beyond remarking that a body of men acting without premeditation or concert, rarely do intentional injustice; and that, if Mr. Pouncy received less than justice from the society, an injudicious mode of introducing his discovery was in some degree chargeable for the reception it met.

The perfection of all processes in photography has been attained by slight steps, and the contributed suggestions of many persons. This is not less true of carbon processes and photolithographic processes than of other branches. Nevertheless, Mr. Pouncy's is a distinct advance, not less the result of a happy ingenuity than of careful experiment. Mr. Sutton refers the first use of asphaltum to Nicéphore Niepce, and reminds his readers that he (Mr. Sutton) was the first to experiment and publish results with the use of a greasy ink, results which probably suggested the transfer processes of Asser, Osborne and James. He adds:

But no one, to the best of my knowledge, had ever used a mixture of asphaltum and printer's ink as a sensitive coating applied to paper, before Mr. Pouncy employed it in that way, and to him is due the whole merit of utilizing this mixture in the manner described in his patent. In this respect he has proved that he is something more than the mere industrious worker out of other men's ideas; and that he is truly an inventor and pioneer, as ingenious in resources as he is indefatigable in experiment.

We believe Mr. Sutton is right, although it is quite possible that we shall learn ere long that asphaltum played a part in the pictures of Watt, or Bolton, or Wedgwood. The nearest approximation to Mr. Pouncy's mixture is to be found in Mr. Gibbon's process described before the Glasgow Society on the 7th of last January, by Mr. Mactear. In this method, copal varnish, linseed oil, Brunswick black, mastic varnish, and turpentine,—all elements of printing or transfer ink—are combined with bicarbonate of potash. This mixture is, however, for application to a lithographic stone, and not to paper for producing a proof direct from a negative, as in Mr. Pouncy's ingenious process.

Mr. Sutton, in describing the process, practically ignores the use of bichromate of potash, using asphaltum as the sensitive agent, remarking in another place that it is doubtful whether the addition of the former is attended with an good effect. Mr. Pouncy expressed his regret to us that its insolubility prevented him from adding a larger proportion than he did, as the paper would be much more sensitive if more could be added. We then suggested, as a method of adding more, that it should be dissolved in a very small quantity of water, and by the aid of an alkali combined with the greasy ink. Since then we have tried the experiment, and have thus combined bichromate of potash with ordinary printers' ink, which, on being applied to albumenized paper and exposed to light, become insoluble in turpentine, just the condition required. Other engagements have prevented us from following out the experiment to further practical results. But we mention the fact for the benefit of other experimentalists.

We have already occupied more space than we intended but we shall probably, on another occasion, make another extract from this interesting pamphlet.

JOTTINGS FROM THE NOTE-BOOK OF A "PHOTOGRAPHER'S ASSISTANT."

No. I.—THE IMPORTANCE OF PHOTOGRAPHY.

NOTWITHSTANDING the many and continued efforts put forth by photographers, in order that the capabilities of their art may be fully developed, the vast improvements which

have already been effected, the rapid pace at which it still advances, and the popularity it has attained, in spite of all these advantages, its recognised position remains anything but satisfactory; like the illustrious Pickwick when he lighted unwittingly among the sage provincial politicians, it is regarded with the green eye of suspicion, whichever side it turns for sympathy; science will not acknowledge it, and art repudiates its claims to kindredship with an air as scornful as the purse-proud squire would refuse the proffered hand of a poor relation. The absence of its representative in that brilliant array of intellect recently assembled in the north, proves that the stars of science are unwilling to give it a place, even as an humble satellite in their too exclusive system. Again, those suns of art, at whose magic touch forms of life and beauty spring into existence pure and bright as angels' smiles, glowing in all the richness of nature's colouring, the bosom of the once despised canvas at their command becomes an object of intense interest, and crowds rush on to do homage before the shrine of that genius, who obstinately refuse one ray of warmth yielding encouragement to their less aspiring, though no less deserving, handmaid.

In seeking out the root of these prejudices, we find that, like the shrine-makers of Ephesus, the acknowledged luminaries of science and art consider the progress of photography endangers their craft. We admit willingly that the *influence of scientific pedantry is endangered, whilst that of the genuine son of art or science is largely increased.* There exist scientific pretenders who have long enjoyed a privileged existence, separated from the common masses by a broad line of demarcation. They have fortified their position with an outpost of mysterious technology; weak points have been guarded with hard-sounding words, to sear ordinary minds from an attempt to scale their interpretation, and to render their position more impregnable, huge embankments of unintelligible theories have been raised, and here those philosophers take their stand: armed to the teeth with logic, they defy the lilliputian world before them, and any attempt to enroach on their ground is speedily met by a crushing volley of wordy projectiles.

Photography is destined to break through these formidable impediments. Based on principles that form the very groundwork of natural philosophy, it is silently cutting a trench through which ordinary mortals may travel free from any risk of stumbling over a memory-splitting nomenclature. Taking photographic art as a basis for scientific inquiry, the task is converted into pleasure. Take, as an illustration, optical science with its mysterious array of sines, angles, and dotted arrows: viewed with a photographic eye, these become fascinating. Invisible rays of light bear on their wings living pictures; the lens, like the human eye it so beautifully imitates, collects and arranges each ray as it comes under its refractive influence. Chemistry now steps in, at whose word those fairy-like scenes assume a new existence and start into a new being as a vivid and truthful reality. Works of art, curiosities of nature, fossils that speak of ages long gone by, when monsters wandered unmolested o'er a sinless world; wondrous monuments of art raised by the industry of men whose natural bodies have long since mouldered into dust; the living forms of a still existing race, from the aborigines of comparatively unexplored regions to the high and mighty ones of a civilized world; the monarch on the throne; the inmates of the humble cottage; old age and infancy; all these forms has the lens filtered from surrounding light, and chemistry has set its lasting seal on the otherwise fleeting picture, thus giving existence to a promoter of tastes that will assuredly bear fruits glorious to contemplate. Our art has awakened curiosity, its practice is not confined to rank or station, its followers may be numbered by thousands, each more or less study its leading principles; these embrace the rudiments of scientific research; a desire for increased knowledge is excited and the world will grow the wiser and better for the change. Fain would we enlarge widely on this sense-

enthraling theme, but space bids us close a jotting intended to awaken an interest in the minds of photographers to remarks of a practical nature that will form the subject of future jottings. As "printing difficulties" is the all but universal cry, printing difficulties, for a time, we select for a theme, and as far as our ability permits, will endeavour to prove that printing troubles will vanish when touched with the magic rod of a well grounded and thoroughly understood system.

PHOTOGRAPHIC CHEMICALS:

THEIR MANUFACTURE, ADULTERATION, AND ANALYSIS.

THE other compounds of arsenic, together with those of antimony, tellurium, and bismuth, are of too little interest to the photographer, to require mentioning in these chapters. The metal zinc next claims our attention. This is very largely used in laboratories for the preparation of hydrogen gas. For many purposes commercial zinc answers sufficiently well for the preparation of this gas: it should be granulated in the following way:—The metal is melted in an earthen crucible, a little powdered charcoal being put on the top to hinder the oxidation somewhat. When melted, stir with an iron rod, but do not let the temperature rise much above the melting point. Have ready a pail nearly full of water; scrape off the charcoal and scum from the surface of the metal with an iron spoon, and then grasp the crucible with a pair of tongs, hold it about three feet above the surface of the water, and pour the metal into it in a thin stream. The melted metal will, of course, produce considerable noise on contact with the water, but no danger need be apprehended. The zinc will now be seen to form a bulky conical pyramid in the pail; it must be transferred to a cloth and quickly dried in a warm place. This process of granulating yields the metal in a state peculiarly adapted for the preparation of hydrogen gas, as it is divided into small pieces, exposing a considerable surface for the action of acids. Zinc is liable to contain a great many impurities, varying considerably with the source whence the metal is obtained. Manganese, arsenic, antimony, cadmium, tin, lead, iron, cobalt, nickel, and copper, are all liable to be present. Most of these can be separated by distillation; but unfortunately, the arsenic and antimony, which are by far the most important impurities, cannot be got rid of in this manner.

According to Maillet, the arsenic may be removed by fusing commercial zinc and granulating it as above described, but at a high temperature, so as to get it in as fine a state of division as possible. Four parts of this granulated zinc, together with one part of nitre, are then placed in a crucible in such a manner that there may be a small portion of free nitre both at top and bottom, and the whole is heated in the furnace till vivid combustion ensues. The crucible is then taken out, the slag removed, and the zinc either poured into water or into a mould. The absence of arsenic may be ascertained by dissolving some of the zinc in pure dilute sulphuric acid, and allowing the evolved gas to pass along a German glass tube, one portion of which is kept at a red heat. If arsenic be present, a dark coloured ring of this metal will be gradually formed round the tube where the heat has been applied. If no deposit takes place after half an hour, the zinc may be considered free from arsenic. It may frequently happen that arsenic will be found in this manner, when pure zinc is used, as sulphuric acid almost always contains a certain quantity of this body. It will, of course, be necessary to have the acid free from arsenic before a trustworthy test can be applied to the zinc. A method of obtaining sulphuric acid sufficiently pure will be given subsequently.

Besides its use in preparing hydrogen, zinc is largely consumed in galvanic batteries. Pure zinc is not necessary for this latter purpose, as the process of amalgamation which battery zincs always undergo, renders the ordinary impurities of no moment. The effect of amalgamation is very curious.

An amalgamated zinc plate put into dilute sulphuric acid is violently attacked, torrents of hydrogen being evolved; if a drop of mercury is poured on to it, the evolution of gas ceases instantly, and the amalgamated metal now behaves towards the acid as though it were absolutely pure: pure zinc being very difficultly soluble in sulphuric acid. For galvanic purposes, zinc should always be well amalgamated, as local action, that is, solution of the zinc when the battery is not at work, is avoided. When the zinc plates of the battery are not in use they should always be kept in dilute sulphuric acid, about one part of acid to thirty or forty of water; by this means the surface is always kept bright and ready for use. The loss by solution is scarcely appreciable, and when the battery is wanted the tedious operation of cleaning and re-amalgamating the zinc is avoided. Should they ever require reamalgamation, it is only necessary to place a drop of mercury on the centre of each plate, and it will run over without further trouble.

Zinc is a very crystalline metal. At the ordinary temperature it is very hard and difficult to bend. At a little above the boiling point of water, however, it is very ductile and malleable, and may be readily bent into any desired shape. If the temperature be raised a little higher it becomes brittle again, and at 205° C. it is so brittle that it may be pounded in a mortar. Zinc fuses below redness, but above the melting point of lead; at a white heat it boils, and may be readily distilled. It is tolerably permanent in the air, becoming coated with a thin grey film, which prevents further oxidation. In moist air, in the presence of carbonic acid, a white tarnish forms on it. When zinc is heated to redness in the air it burns with a dazzling bluish and greenish flame, and forms oxide of zinc, which floats about the room and falls down in large flakes like wool. In this form oxide of zinc is an excessively light powder, but, by appropriate means, the oxide can be prepared in a much denser form, and in that state is largely used as a pigment, under the name of zinc white. It has the great advantage over white lead, that it is not darkened by sulphuretted hydrogen, the sulphide of zinc being white. When first introduced, zinc white was not liked on account of its not having so much body as white lead, but it is gradually gaining ground by reason of its other valuable properties. For miniature painting it should always be employed in preference to white lead.

We have met with some samples of zinc white containing a large amount of impurity, sufficient, indeed, to cause it to darken when exposed to the action of sulphuretted hydrogen. This impure zinc white is generally seen to have a less brilliant colour than the best quality, and it is at once darkened upon the addition of a little dilute sulphide of ammonium or sulphuretted hydrogen water. This test should always be applied by artists.

PHOTOLITHOGRAPHY.

No. III.

BY JOSEPH LEWIS.

VARIOUS METHODS OF OBTAINING A PRINTING SURFACE.

From the rapid multiplication of the methods introduced, it becomes advisable to attempt a classification of the various processes contrived to produce a printing surface for the press by the actinic influence of light, without regard to the nature of the original, whether it be itself a photograph or otherwise produced, according to the following order or class:—

- 1st. The sensitive salts of silver.
- 2nd. The sensitive resins, oils, and bitumen.
- 3rd. The chromic salts and organic media.
- 4th. Some of the above in combination.

This classification embraces the various methods of producing a photo-printing surface by means of the lithographic

principle, which is based on the fact that water is repelled by grease, and *vice versa*.

The processes hereinafter described, and also that in my second article, at page 214, come immediately under the first division. An inked surface is made the foundation for the sensitive film.

2. An unvarnished negative (collodion) is treated in same manner as for transferring positives to leather, by detaching the film by acid and alcohol, and a card being already coated with sticky transfer ink, the film is transferred to the inked surface by a light pressure. Ether and alcohol are now to be plentifully applied to dissolve off the collodion covering the shadows of the picture, thereby exposing the bare greasy ink surface which may be at once transferred to stone or plate by pressure. The greatest difficulty experienced in this method is owing to the uncertainty of getting an effectual solvent for the collodion film. The nature of the collodion used is the source of the trouble; some samples dissolve off readily, leaving the reduced silver on the ink with all the gradations of tint perfectly rendered, while other samples are so immovable that nothing will effect their dissolution.

3. By forming upon the surface of a collodion negative a deep deposit of the mercurial salt and oxide in intensifying, and for this method there are some descriptions of collodion specially suited, as the image should be entirely on the surface, so that it can be easily wiped off, when the negative exists in that condition it is admirably suited for the purpose, as may be proved by pressing a card coated with ink firmly against it. If it takes up the fugitive particles effectually from the plate, it may at once be turned over on the stone and transferred by pressure, the deposit taken from the plate preventing the ink from contact with the stone, as in 2. By this process an exceedingly minute transfer is obtained, but the utmost precaution is necessary in applying the inked card, as the collodion film sometimes is stripped from the glass, and in that case destroys both transfer and negative.

4. By the following process I get rid of the difficulty of the intervening collodion film (2). Twenty years ago, Sir J. W. Herschell proposed to substitute glass plates for paper in the photographic processes of that date. A flat-bottomed deep vessel was filled with pure water, to which a small quantity of muriate of soda and hydriodate of potassa was added, then a few drops of nitrate of silver. The whole well stirred, when the liquid becomes of a milky appearance. Clean glass plates are then spread over the bottom of the vessel, and the sensitive coating deposits itself in a fine even film on the upper surface of the glass plates; in the course of a few hours the clear water is drawn off by a plug or syphon, but before completely drying I prefer to apply a coating of dextrine and glycerine and nitrate of silver from the ordinary negative bath. When dry it is ready for exposure, under a positive, on glass or waxed paper, and when properly fixed, the deposit comprising the picture can readily be detached from the glass on to an inked card for transferring, or I sometimes transfer the film to the inked surface, before fixing, with advantage.

NOTE.—Referring to the process described at 2, I have to state that on several occasions I have succeeded in charging portions of a collodion negative with printing-ink, after the manner of lithography. It might have been that some greasy vapour or substance had come into contact with the plate either after or before fixing, and was absorbed by the insoluble deposit. Should this prove correct, the process based upon it will be invaluable, as we may then, by exposing an unfixed collodion image to the vapour of hot oil or other greasy substance, the cyanide will, in dissolving off the unreduced silver, carry with it the grease on those parts, but it will adhere to the reduced silver, and afterwards, when wetted, repel the water on those parts, and so become charged with the ink.

THE MANUFACTURE OF PHOTOGRAPHIC COLLODION.*

BY W. L. NOVERRE.

PRECAUTIONS.

The fumes of nitric or nitro-sulphuric acids must not be inhaled, as they are exceedingly poisonous. In carrying an open vessel of the acids from one room to another hold it well up above the head, in this way the fumes will be avoided. Care must be taken that the acids are not allowed to fall or splash on the hands, face, or clothes, as they are very corrosive. They stain the skin and nails yellow, and destroy every kind of fabric. If any acid gets on the hands, rinse in water at once; ammonia, if applied immediately, will sometimes remove the stain from woollen materials. When opening a bottle of nitric acid hold it at some distance from the person to avoid a sudden rush of fumes. When pouring out the acids, place the neck of the bottle in contact with the measure, and let the acid flow out gently to avoid its splashing. Do not attempt to mix the acids in any kind of vessel that would be likely to break from being suddenly heated, and on no account in a bottle. With proper care the operation may be conducted without allowing the acids to come in contact with the hands. India-rubber gloves will, however, afford entire protection, and an apron of green baize will be found very useful to prevent the clothes being splashed with acid. There is no fear of the pyroxyline exploding or taking fire spontaneously during the process of manufacture or after it has been dried, provided that fire does not come in contact with it, and that it is not exposed to a higher temperature than 300° Fah., a little above which it will take fire.

A plan has been given for concentrating weak acids to a suitable strength, by heating till the superfluous water has evaporated. This operation requires care. It must be conducted under a chimney that the fumes may be carried away. Too large a quantity should not be operated on at one time, so that in case of the apparatus breaking less acid will be spilled. It must not be heated too much, or the acid will bump and splash. The dish in which the acids have been heated must not be placed on a cold substance immediately after removal from the hot sand bath, for fear of fracture, and the acid should be placed in a bottle as soon as it is cool that it may not absorb water from the atmosphere. A high temperature will be required for heating the sulphuric acid, as it does not boil till it reaches 572° Fah.

THE PYROXYLINE.

Although the same general directions will apply for making pyroxyline by any formula, the process will be more easily understood if a particular formula is taken as an example. We will therefore select that given by Mr. G. Wharton Simpson, as being simple and yielding very satisfactory and uniform results.

The formula stands thus:—In a mixture of sulphuric acid sp. gr. 1.840, and of commercial nitric acid sp. gr. 1.420, each 6 ounces fluid, immerse 4 drachms of best American cotton, to be left in for ten minutes at a temperature of 150° Fah. The increase of weight after washing and drying should be from 30 to 50 per cent. We will suppose that the specific gravity of the acids has been tested and found correct.

A convenient quantity of acids to manipulate with at one operation is 12 ounces. Everything should be got ready before the acids are mixed. The cotton should be weighed, pulled out into ten or twelve separate tufts and placed on a sheet of paper, close at hand. If a kitchen range is employed for the operation, the cotton may be placed on the hob, or on a chair near the fire-place. Put a saucepan of water on the fire, and allow it to boil gently; have a dinner-plate on the hob, on which the thermometer, the spatulas, and the cover of the jar may be placed; stand a bucket full of cold water near the fire-place; have a breakfast cup at hand, in which the acids may be pressed from the cotton, and a pan

of water to rinse the fingers, in case any acid gets on them. Lastly, take care that all the articles to be used are perfectly dry. When these preparations are complete, and the water in the saucepan boils, measure out the sulphuric acid, and pour into the jar (next the water, when any is required), and then the nitric acid; the jar may be filled on the hob, or on a table near the fire. When the acids are measured out, lay hold of the jar by its handle, and stir the acids well with a glass spatula, to insure thorough admixture, this is important; put the spatula down on the plate, and immerse the thermometer; if the temperature is not sufficiently high, place the jar in the saucepan, leaving the thermometer in the acids, and watch the mercury rise; when it reaches the proper height, move the thermometer up and down, to be sure that the temperature is the same all through. Lay the thermometer on the plate, place the jar of acids on the hob, and immerse the cotton, piece by piece, pressing down each tuft under the acids and against the sides of the jar, so as to expel the bubbles of air. No time must be lost in performing this part of the operation; at the same time, it must not be hurried over, because if the bubbles of air are not pressed out, the acids will be rapidly oxydized, and the cotton dissolved, with evolution of red fumes. The same accident is liable to occur if the cotton is allowed to project above the surface of the acid during immersion. When the last tuft of cotton has been put in, the mass should be loosened with a spatula, to prevent it from sticking in a lump at the bottom of the jar, the object being to let the acid have access to every part, that it may act uniformly on the fibre, it should be worked about in the middle so as to make a space for the thermometer. The temperature generally falls three or four degrees during the operation of putting in the cotton; it will therefore be necessary to place the jar in the saucepan again to raise the temperature to the exact point. The thermometer should be kept moving and carefully watched till the proper temperature is reached, when the thermometer may be withdrawn and the jar placed on the hob again and covered over. The cotton has to be left in the acids for ten minutes; this may be calculated from the time the last tuft was immersed or from the time that the acids were covered over after having been raised a second to the correct temperature. If by the latter method the cotton is found to be too much acted on by the acids, adopt the former plan, and adhere to it in future operations. Perhaps a more accurate method than the above is to allow a few degrees for the fall of temperature during the operation of putting in the cotton, having, on previous occasions, observed the difference of temperature before and after the immersion; thus, to re-immers the 240 grains of cotton divided into 10 tufts in 12 ounces of acid will take about 2 minutes (or less in the case of cotton purified with potash). During this time the temperature will generally have fallen about five degrees, unless the spatula was first heated, which would make a difference of two or three degrees, so that, supposing we intend to work at a temperature of 150°, the cotton should be immersed at 155°, thus allowing 5° for the fall of temperature between immersing the first and last tuft: the jar can then be covered over and left for the requisite time. The thermometer may be left in the acids to see that the temperature does not fall, a hole being made for it in the cover of the jar or a glass plate substituted for it, a space being left on one side for the stem of the thermometer. When working in the manner described the proximity of the jar to the fire will generally keep the temperature the same for ten or fifteen minutes; in this case the thermometer need not be left in the acids, but after 5 minutes it may be immersed to ascertain that the temperature has not fallen. If the jar does not stand near a fire, the temperature will generally fall a few degrees, although it may be prevented by wrapping cloths round the jar. If the temperature falls before the expiration of the 10 minutes, the jar should be placed in the saucepan of hot water till the correct temperature is obtained. If the temperature should have acci-

* Continued from p. 436.

dentally been allowed to rise too high, it may be reduced by moving a cold spatula up and down in the acid.

When the cotton has been immersed the proper time, push the spatulas down to the bottom of the jar on each side, raise the cotton in one lump, and put it into the breakfast cup; hold the cup firmly by the handle, and press as much acid as possible from the cotton with one of the spatulas, pouring it back into the jar; this must not occupy above 30 or 40 seconds; next plunge the cup and its contents into the pail of water, lay hold of the cotton with the other hand and move it rapidly about, distributing it through the water, the ball of cotton when first laid hold of will feel quite warm to the hand, and if not moved about so as to reduce the temperature it would be spoiled. On this account it is important that a large quantity of water should be employed. The water should be changed frequently and the cotton worked about till it ceases to taste acid, it should then be kept in a running stream, or in a large pan of water constantly changed for about 12 hours. Before removing the cotton a piece of blue litmus paper may be kept in the water for half an hour, to ascertain that all the acid has been washed out. Before making another batch of pyroxyline, the jar, measures, and other apparatus must be rinsed out and dried. When the washing is complete squeeze the cotton in the hand, then pull it out and spread it on a clean cloth, roll up the cloth with the cotton in it, and wring it thoroughly; repeat the operation with another dry cloth till no more moisture can be wrung from it, then pull it out into loose tufts, spread on a large sheet of paper and place in the sun or in some warm place to dry. If it is dipped in alcohol after the water has been pressed out and then wrung again it will dry much more rapidly. Artificial heat on a water bath or other contrivance may be used where fire can have no access to the pyroxyline, which is explosive and very combustible; it must be dried at a sufficiently low temperature to prevent decomposition. Some kinds of pyroxyline decompose at a lower temperature than others; 140° Fahr. is generally considered the safest point.

An experienced person can generally tell pretty well when the cotton is washing whether it is of the proper quality, but the most reliable test (providing none of the cotton has been lost in washing) is its weight after the operation; in the formula under consideration, the increase of weight should be from 30 to 50 per cent., the best plan being to try and keep it as near 40 per cent. increase as possible. The cotton must be thoroughly dried before it is weighed or it will appear heavier than it really is. To ascertain that the pyroxyline is quite dry it is a good plan to allow it a few hours drying after it has been weighed, and then to weigh it a second time; this will show at once if it was dry the first time or not. A good pyroxyline for a bromo-iodized collodion for the wet process should be such that five or six grains dissolved in one ounce of a mixture of alcohol and ether will yield a collodion which runs easily on the glass, and forms, when dry, an even, structureless, and perfectly transparent film. If, however, with a view to bring about this condition, the acids have been made too weak, or the temperature has been too high, a portion of the cotton will have become converted into nitroglucose, which substance increases the intensity of the collodion, and causes it to decompose too rapidly after iodizing. These qualities are, however, suitable for a dry process collodion; therefore, if it is found that the pyroxyline has not increased in weight as much as 30 per cent., and does not weigh less than it did before immersion in the acids, it may be used for dry collodion; if the weight is less than that of the original cotton, it will be almost too rotten for a sensitive dry process collodion. If, on the other hand, the increase of weight is more than 50 per cent., it will be found that 5 grains dissolved in an ounce of the solvents will give a slimy collodion running over the glass with difficulty. If diluted to a proper consistency it would be wanting in intensity, and quite unsuitable for the wet process, but it would probably do well for a positive collodion, which ought not to possess

as much intensity as that intended for the wet process. If the pyroxyline is too heavy, a little water must be added to the acids for the next batch: try the addition of a dram at a time to 12 ounces of the mixed acids, till the desired kind of pyroxyline is obtained, and in future operations with acids of that strength, the same quantity of water must be employed. If, instead of the acids of the strength named by Mr. Simpson, we use sulphuric acid, sp. gr. 1.85, and pure nitric acid, sp. gr. 1.420, we shall find that with other conditions the same, we must add 3 drachms of water to every 12 ounces of the mixed acids in order to produce a pyroxyline from 40 to 45 per cent. heavier than the original cotton.

If, on the other hand, the pyroxyline is too light, we know that the acid mixture is too weak, that the temperature was too high, or that the cotton was left in too long.

It may occur that on testing the specific gravity of the acid we have to use, we find it is much weaker than that given in the formula; in that case the quantity of sulphuric acid must be increased according to the strength of the acids; if they are very weak, six parts sulphuric may be required to four parts of nitric, and if this formula will not yield a pyroxyline of the proper quality, the acids had better be rejected.

In making a cotton purposely for dry collodion processes, the temperature may be raised to 165° Fahr. In this case, the weight of the pyroxyline will be nearly the same as that of the original cotton. A pyroxyline for positive collodion may be made by reducing the temperature to 140° or 135°, the increase of weight will then be about 60 per cent.

Pyroxyline should be kept so that the air may have access to it; a tin box with holes in the lid is very convenient for the purpose, it should not be packed too tightly.

(To be continued.)

THE ANALOGY OF THE EYE TO AN OPTICAL INSTRUMENT.

BY J. Z. LAURENCE, F.R.C.S., M.B.*

THE analogy of the eye to an optical instrument has, from the earliest times, attracted the attention of philosophers; hence their efforts to apply the ordinary laws of optics to the resolution of the various problems of vision. By none have these been adapted with greater felicitude than by our great countrymen, Young and Porterfield. But nearly all these researches referred to physiological optics. The study of the pathological deviations of the dioptric system of the eye is of comparatively modern growth. All I know is, that when I was a student, the knowledge I had imparted to me was limited to the fact that concave glasses improve myopia, convex ones, presbyopia, and that the selection of the precise power required for any given case was an entire matter of rude empirical trial.

The basis of the exact knowledge we now possess of pathological optics were the discoveries of Cramer and Helmholtz, who have for ever solved the much-veiled question of the adjustment or accommodation of the eye to different distances, when they proved it to depend on a change of convexity of the crystalline lens, and that this was effected by the ciliary muscle. We then come to the researches of Professor Donders, of Utrecht. He, for the first time, insisted on the absolute necessity of separating the two factors, refraction and accommodation; to adopt the language of mathematics, the 'constant from the variable.' None but those who have intimately studied the subject can form any conception of the importance of this one simple step: of the precision it has conferred on our ideas—how it has smoothed the path for all future researches. Donders recognises three conditions of refraction—1st, normal; 2nd, excessive (myopia); 3rd, deficient (hypermetropia). The

* From an able and eloquent oration on "The Progress of Ophthalmic Surgery," delivered by the author before the North London Medical Society, and just published by Churchill.

first step in the investigation of any given case is to refer it to one of these three classes, then to estimate the precise amount of refraction—the 'power'—of the eye. Having thus determined the constant, we may examine the variable—accommodation—and thus finally form a complete analysis of the case. To adopt a familiar simile—if we wished to investigate the qualities of a telescope, we should first test its powers of defining distant objects, as the heavenly bodies, and then those of adjustment for near objects at variable distances. The first elements of science appear in the form of isolated facts. As these multiply, a kind of mutual connection appears possible. Possibility becomes successively probability; probability, certainty. And thus the individual truths of science, like the wheels and pinions of the engine, become all subservient to one great common end. In no branch of science has this been better exemplified than in what has almost become a speciality of a speciality—viz., our knowledge of the deviations of refraction and accommodation of the eye. Within the last year, Donders has again added to our knowledge of this subject by an elaborate treatise on Astigmatism.

Astigmatism (coined by Professor Whewell, from a privativum and *στίγμα*, point=focus) is an inequality of refractive power in the different meridians of the eyeball—understanding by the term meridian, as in astronomy, a great circle passing through the poles. Practically, we may limit our investigations to the horizontal and vertical meridians of the eyeball. Thomas Young, in 1793,* was the first to discover this peculiarity in his own eye; this "in a state of relaxation collects to a focus on the retina those rays which diverge vertically from an object at the distance of ten inches from the cornea, and the rays which diverge horizontally from an object at seven inches distance."† Consequently, the refraction of his globe was greater in the horizontal, than in the vertical meridian. In 1827, Professor Airy published a remarkable instance of the same anomaly in his own (left) eye.‡ In this, the furthest point of distinct vision for vertical rays was three and a half inches; for horizontal ones, six inches; the eyeball thus being nearly double as myopic in the vertical, as in the horizontal meridian. To Airy likewise belongs the merit of first having applied cylindrical glasses to the cure of astigmatism. This has been shown by exact measurements to depend generally on an inequality of curvature of the vertical and horizontal meridians of the cornea. It may, however, as in Young's case, originate in an irregularity of curvature or position of the crystalline lens. Astigmatism is remediable by cylindrical lenses. These represent sections of cylinders parallel to their axes. Such lenses have the peculiarity of exerting a lenticular (refracting) influence on rays striking them transversely to the axis, allowing those striking them parallel to the axis to pass through no more refracted, than they would be by a piece of plane glass. Thus we may add to or subtract from, by cylindrical, convex or concave lenses, the refractive power of one meridian of the globe, leaving the other unchanged, and thus restore the equality of refraction in the two meridians—correct the astigmatism.

Up to the period of Donders's recent researches, only eleven cases of this optical defect had been recorded. He has shown that astigmatism is really a very common disturbing cause of vision, and that many cases hitherto but imperfectly correctible by ordinary (spherical) lenses, are almost completely so by cylindrical ones, either alone or conjoined with spherical ones.

NATIONAL PHOTOGRAPHIC PORTRAIT MUSEUM.‡

PHOTOGRAPHY stands in the foremost rank as a great civilizer: it enters into every grade of society, from the Queen on the throne to the peasant in his humble cottage; and it

affords to those engaged in commerce a cheap and faithful means of distributing exact copies of their productions for the benefit of all. The most intricate mechanism is copied as easily as the most simple; the artist avails himself of its wondrous powers, as does also the architect; and the lecturer employs it with the magic lantern as the means of showing instantly to his audience places and things that, with the most eloquent tongue, he would be utterly unable to describe.

We have used it selfishly to supply our own wants, and oftentimes to gratify our own vanities. But we may, if we will, use it for a purpose far more noble than any it has yet been applied to. By its aid we may raise a monument to all men and women that are great and good, and one that shall be more lasting and far more truthful than the cold and unimpassioned marble; in fact, we can secure the perfect image of the human being instinct with life, and so preserve it that it shall be a monument for all time to his or her memory, that will afford to generations yet unborn the high gratification of looking upon those who have lived centuries before themselves, and who, by their patriotism and genius, have helped to make the world what it is. What would we not give to possess faithful portraits of the illustrious dead? that we might look upon them face to face as they walked the earth. Had the art been known in the days of Socrates, Dante, or Shakspeare, we might have possessed photographs of these and thousands of others; but as we cannot raise the images of the mighty dead, we may preserve for all time the illustrious living.

It will be asked how can all this be secured. Very easily, as will be seen from the following suggestion of Mr. MacLachlan:—Photographs, no doubt, at present are not to be depended upon as lasting memorials, but the original negatives are as lasting as the material (glass) upon which they are taken. The plan proposed is to secure the negative plates of great men, and have them placed in a museum for safe keeping, properly authenticated, attested, and registered by the mayor or other authority of the place where they are taken; and, to provide against accidents, it is proposed to secure in every instance, three plates of the same individual, which can easily be done, as the original one can be always reproduced at pleasure.

The object of securing these plates is, that one may be kept within the institution, and the other two lent, at the discretion of the authorities in charge: for instance, to any author of eminence for book illustration; and by that means the memories and images of those who have been great and passed away would be transmitted faithfully to all posterity. In almost every instance there would be several portraits of the same individual in different museums in the country, affording a still greater security for their permanent preservation. All local celebrities might be taken in their own towns and deposited in the museums of their respective localities, and should a time arrive when their genius became acknowledged by the world, then they might claim a shrine in our great National Museum. There would necessarily be a few simple rules to guide us in the selection of the proper kind of plates to deposit, which it is needless to enter into here.

Portraits can be taken so small that thousands of them would not occupy one square foot, and at the same time could be enlarged to life or any other size at pleasure.

As to cost:—Mr. MacLachlan offers his best services in photographing any persons who may be deemed worthy, esteeming it an honour, and he believes his brothers in the art would assist as freely as himself.

The space required for the due preservation of these negatives is very small. As many as five or six thousand could easily be stowed, ready for reference at all times, in a couple of presses of ordinary size.

PHOTOGRAPHIC PICTURES AND ILLUSTRATIONS.

[Some months ago the *London Review* published a very offensive and unjust article on photography. It has recently atoned for this by the issue of one or two articles at once just,

* "Philosophical Transactions," vol. lxxviii. p. 169.

† "Philosophical Transactions" for 1801.

‡ "Transactions of the Cambridge Phil. Soc." for 1827, vol. ii. p. 267.

§ *Journal of the Society of Arts.*

appreciative and instructive. We publish the last first, and shall add the other, if we have space, another week.—Ed.]

LAST week we dealt with photographers in their power of copying. What shall we say to their power of producing original pictures. This, with merely mechanical and optical means, would appear an almost hopeless task, and that attempts of this sort usually fail, is not surprising. Rejlander has, however, produced some very clever things; not so thoroughly perfect as we could wish, but fine indications worthy of high rank. Rejlander has all the genius for seizing on thorough artistic incidents. He groups his figures and poises them with admirable skill, raises somehow in his subjects the very look, action, and point required, and catches the happy moment with the quickness of the lightning-flash. But he is to us rather a slovenly chemist and spotty manipulator.* These are harder terms than he deserves; for perhaps it is that the subjects of his witty or genre pictures and the way they are handled make us angry with the artist for not surmounting the defects photography itself is heir to. Who can look at his "Participle-catching" and his "Participle-caught," and not enjoy it as much as one of Hunt's quaint water-colours? You see the boy's hand stealing gradually towards the fly; then you can almost hear the insect buzzing in it. In his "At Work," "At Rest," "At Play," you comprehend alike the grey-haired grandpapa and the flaxen-haired child. His "Street Fiddler," and his "Night in Town" are powerfully painful, the "dark within and light without" comes touchingly from the blind woman's sightless eyes; while the poor ragged boy sleeping on the door-step, his comfortless night in town becomes the more touching from the incident that gave rise to the picture,—"Take him away!" unfeeling ordered the well-to-do tradesman, returning in the small hours of the night from his carousal, directing the policeman to the poor, shivering outcast. "Throw the light of your lantern upon him," said the passing photographer; and the poor lad went his way rejoicing, with half a crown in his threadbare pocket, instead of finishing his sleep with drunkards and thieves in the station house. Six times on his head for a halfpenny gives the topic for "A Day in Town; and good as this is, it is beaten in humor by, "Jim, is it a good 'un?" in which the knowing look of the boy, as he bites the sixpence, is exquisite. "The Two Ways of Life" is another composition picture, by Mr. Rejlander, of a more pretentious kind, composed of very numerous figures telling the two stories in forcible terms, and replete with incidents and expression.

What we have so far noticed are what may be called in photography works of high art. There are, however, more familiar phases of photography; and these are the more important as it is the familiar and common uses of an art that produce the greatest and most extensive effects. Of these, two will instantly occur to every mind—the *cartes de visite* and the smaller class of stereoscopic views. These are not only an industry in themselves, but have given rise to other extensive businesses in the manufacture of albums and hand-stereoscopes. The small portraits known under the former title should not be regarded in the aspect of supplanters of the fine miniatures of the old school of miniature painters, although unfortunately they are so, but rather should we take a wider view, and regard them as annihilating those disgracers of art to whom the less wealthy were forced to apply to gratify those desires to preserve something of the forms and faces of those who were near and dear. In the olden time it was some parent, child, or friend whose features were thus perpetuated; and how common and how deep were the regrets in many a breast that nothing more like the departed remained! Now the humblest amongst us may cherish the remembrance of parent or child; and in the setting of life, in the space of a pocket-book, we can enter, visually at least, again into the presence of long-lost friends, and recur to many a long-past scene. The family portrait, too, in ponderous golden frame, hanging from the wall, is either ever painfully present or familiarly unnoticed; but the card-

like photograph comes out in silence and solitude at the holiest moments of uninterrupted thought. And so cheap and so facile is the photographer's portrait-taking, that even curiosity, as well as affection, can be gratified.

Mr. Swann's casket portraits are very pretty and ingenious articles, suitable for presents or for mementos of those closer friends or relatives of whom we might wish to have some special token of remembrance. They are small photographs, carefully coloured and mounted on two sides of a glass prism set in a casket or case of any size, from that of a *châtelaine* ornament to three or four inches in height, the effect of the prism being to commingle, in a perfectly stereoscopic manner, the two views, and, on looking into the casket, a life-like bust is seen.

The numerous views of places and scenery, especially the stereoscopic ones, are sources of great instruction and knowledge, and amongst the most entertaining and beneficial amusements ever introduced into our homes. Of these, those by Wilson of Aberdeen are pre-eminent for every artistic and pictorial quality—as witness his "Hawthornden," "Lower Fall of Moness, Aberfeldy," "A Bit in the Trosachs," "Ben A'on—Loch Katrine," "A Bank of Ferns," "Lincoln Cathedral," "Stonehenge," and "Land's End." The Stereoscopic Company supply us with fine American scenes—"The Broadway, New York," "Wall Street," "Hudson River," "Mountain Gorge in the Catskill," "Niagara," and with views in Canada; and from this and other sources we can obtain pictures of other lands, to study the physical geography and geology of places we could never have the time nor funds to visit.

But all the branches of photography, except portraits and the trade in views along the usual tourists' routes, are at present desultory and capricious in production and sale, although we think it only wants some few practical suggestions to turn the vast amount of material produced to useful and practical ends. The illustration of favourite authors or special subjects with reliable photographs even of the ordinary kinds, would be far preferable employment than potato-mania for young ladies; and even men of intellect and science would not charge efforts in this way as useless and idle. A Bible illustrated with photographs of the Holy Land, Egypt, and of objects referred to in its stirring passages, would be a great inducement to its study by the young, and profitably instructive to many of maturer years. A geography illustrated with nature-printed views of foreign lands, mountains, rivers, and cities would be highly interesting; and even a favourite novelist or poet would not lose in attractiveness by being intercalated with views of the principal scenes. Any particular book or subject might thus be adorned with appropriate views and portraits; just as Mr. Bennett has illustrated his "Ruined Abbeys and Castles on the Wye," and has made a collection of the principal scenes in Scott's "Lady of the Lake." Mr. Lovell Reeve, too, has effectively used photographs in Mr. Piazzi Smyth's "Teneriffe," and is doing so now in his "Biographies of Eminent Men." The two portraits of Carlyle and Tennyson by Mr. Jeffery, about double the size of ordinary *cartes de visite*, are very good and of an admirable size for books or collections of biographies. They form, we believe, part of a series to be published by Messrs. Marion.

A fashion of this kind, for illustrating books and journals, would involve the necessity of publishers selling their views unmounted. The present cards are liable to be lost and to get damaged, which would not be the case if the views were pasted like prints in a scrap-book, diary, or volume. It may be well, however, to remind those who may take a fancy for our suggestion, that mounted photographs can be easily unmounted. They are fastened on to the cardboard with starch—common paste being deleterious—and by simple immersion in warm water, can be safely peeled off without injury, and then remounted in the proper manner. At present, no unmounted photographs can be bought, unless by special order; but the Messrs. Marion, of Soho Square, are contemplating the issue in that state of the very fine series of views in Spain taken not long ago by the late Mr. Clifford, and which remarkably confirmed the opinion we entertained of the value of photography in architecture. Some of the objects selected by Mr. Clifford in his "Scramble through Spain," are perfectly marvellous for their intricacy of detail, as, for example, the tracery of the door of the Hall of Justice at Grenada, the court of the "Casa de Pilatos"—a palace built in the sixteenth century by Don Guizquez de Ribera—and some details of the principal courts of the principal courts of the Alcazar in Seville. Such elaborate

* One word for Mr. Rejlander. Some of his pictures may be charged with slovenly manipulation; but it should be remembered that he frequently works alone, without assistance, and that he is so absorbed with the *thought* in his picture, and with that which belongs to the artistic expression of that thought, that he occasionally loses sight for a time of the mechanical details upon which neatness and spotless manipulation depend. Mr. Rejlander has produced, notwithstanding, some of the finest pictures, *photographically speaking*, as well as in an artistic sense, which have ever been issued.—Ed. PHOTOGRAPHIC NEWS.

subjects could only have been executed by the finest artists, and pictures by any but first-rate men would have been valueless. They were little likely then to have been produced, and photography may be well allowed to do for us without envy what artists would not; and while art can give us pictures beyond the best efforts of the chemist and optician, her followers should be rather urged to grander efforts than to jealousy by the near approach to her realm which modern photographers have by the most earnest efforts attained.

The trade in small photographs is enormous. We were informed by one wholesale house that their monthly sale was 50,000, and this rate could hardly be exceptional. The power, therefore, for good in this branch of industry must be vast indeed.

That there is a tendency springing up to collect photographic views of geographical places, physical scenery, and the finest architectural buildings, is shown by the "latest novelties" in photograph albums. Some of the charming views by Wilson are of very suitable size (6 inches by 4 inches) for illustrative purposes, such as the series he has just executed of "Windsor Castle" and "Roslyn Abbey," the sharpness, precision, aerial perspective, and details of which are rendered with the greatest skill.

Special collections of stereoscopic photographs of any particular class of subjects or objects would also present valuable as well as entertaining results, and introduced in social parties would give rise to much interesting conversation and mutual instruction. Without attempting to develop any new or useful branches of the great trade in photography, we are satisfied now, while publishers are despatching their photographic artists in various directions for new views for the coming season, with pointing out the mines of wealth that at present lie unworked in the publishers' portfolios, and to the stock of which every day's labours are adding. Amongst the first in-comings of these labours for the approaching season, we have already seen some magnificent views in Rome, Venice, Florence, and Pisa, by the Bissons, imported by M. Victor de la Rue. All these are large in size, and many (for there are fifty in all) are of subjects familiar to us through pictures and prints,—such as the "Palace of St. Mark, at Venice," the Leaning Tower of Pisa," the "Cathedral of Milan,"—besides which they may be well placed for comparison, when the overt veracity of these new views of old subjects will not be their least valuable feature. The "Arc des Orfèvres," the "Three Columns of Jupiter Stator," the "Basilica of Constantino," and the full view of "St. Peter's in Rome," the beautiful details of the "Gate of La Loggia," and the "Central Entrance of St. Mark, in Venice," the exquisite minutiae of the panels of the Baptistery gates (fifteenth century), the "Campo Santo," in Pisa," in this series, will assuredly reckon amongst the finest productions of these accomplished artists.—*London Review.*

Correspondence.

FORMIC ACID IN THE DEVELOPER.

SIR,—Can you find space for a few lines on the subject of Sergeant Moss's letter, in your last?

He arrives at the conclusion that "formic acid, added to pyrogallic acid in the developer, as recommended by M. Claudet, is quite as powerful as the ordinary iron developer."

M. Malone, writing of M. Claudet's suggestions, (*vide* article by M. Malone, at page 300, *British Journal*, for August 1), distinctly states that "the avoidance of bromine salts in the collodion is absolutely essential to success." Sergeant Moss tells you he makes his experiments on the developer recommended by M. Claudet "with a collodion containing a considerable proportion of bromine salts."

Sergeant Moss, before entering into experiments with delicate processes, such as the use of formic acid involves, should have known at all events the fundamental rule that to obtain the best results with pyrogallic acid, a simply iodized collodion is required; and, professing to make experiments on M. Claudet's ideas, he should, at all events, have adopted his formula, and worked with them as a basis.

The writer, therefore, has neither made his experiments according to the formula recommended by M. Claudet, as regards pyrogallic acid, nor according to the formula with

iron, to which I myself called attention in your journal some two years since.

And he produced a better negative with the ordinary iron developer than with a developer containing pyrogallic and formic acids!

But having commenced, as I pointed out before, with a collodion wrongly sensitized, his experiments are comparatively valueless.

Even in the original formula for the employment of formic acid in conjunction with pyrogallic acid, published by Mr. Maxwell Lyte many years since, a simply iodized collodion is included.

I must apologise for taking up so much space in alluding to experiments carrying their own inutility so plainly stamped upon them, but I do so in the interest of amateur photographers in general.

I have many letters addressed to myself asking for advice as to the employment of formic acid, as suggested by myself, and doubtless M. Claudet has as many addressed to him, showing the interest taken in the subject. An amateur, reading Sergeant Moss's letter, and not being himself well up in the subject, would naturally conclude that M. Claudet recommends bromo-iodized collodion in his formula. Thus he would be led into a serious error, and find himself disappointed in the process, and would do no justice to M. Claudet's ideas, or, indeed, to the employment of formic acid in general; and in order, as much as possible to prevent novices from being misled by such inexact experiments and conclusions, I address you these few lines.—Truly yours,

H. STUART WORTLEY.
Lieut. Col.

September 14, 1863.

RELATIVE EXPOSURES FOR VARIOUS PROCESSES.

SIR,—I have before addressed you about information needed to enable one to judge of and fairly work different processes. I have now been hunting all your volumes as well as picking up such information as I could get from Hardwich. I have endeavoured to use mainly the information derived from successful workers, where available, and have made a table of exposure constants for the different processes, which will, I trust, be useful.

The equivalent focal length, diameter of stop, and exposure being known, I have found the constants by multiplying the seconds of exposure by the square of the diameter of the stop, and dividing by the square of the focal length.

To use these constants we have only to multiply them by the square of the focal length of the lens we desire to use, and divide by the square of the diameter of stop, to obtain the seconds of exposure.

I do not suppose this will be rigorous or suit all times, but it will be a more reliable guide than the rough estimator of "6 times the exposure of a wet plate," &c., which we so often see. I have spoiled many plates and wasted much time on dry processes, mainly, I believe, from not knowing what the rough exposure should be. You will see tannin and honey is the only process coming near wet collodion. The great objection to honey is its variability. The main accelerator in it is, I apprehend, the grape sugar, but that constantly passes into the crystallized state. In your number of April 2nd, Mr. Verity gives a formula which should be definite in its results. Would he publish more information? The maker could well give the equivalent focal length of his lenses, and if he would give a few exposures for good pictures under average circumstances, with focal length of lens, and stop's diameter, we could glean more from this than from rough comparisons with wet collodion, which varies more than a dry process in sensibility, as far as I can judge. Numbers so obtained are fair exponents of relative sensibility in different processes, and carefully collected data (if photographers would condescend to give them in numbers) would settle various matters in doubt.

Opticians would soon publish their equivalent focal lengths if customers would ask for them, but as each lens, to some extent, varies, it would be desirable for careful men to ascertain the equivalent lengths of their own lenses when purchasing. I may mention that the wet collodion data are by myself, they are derived from work with a Ross orthographic 12.5 inches focal length, a Voightlander portrait lens 11.5 focal length, 3 1/4 inches aperture, and Dallmeyer's 1 B lens, 6 inches equivalent focus, as nearly as possible.

I fear I have exceeded my tether, but I am very anxious to urge on photographers the necessity of passing from indefinite opinions to definite numbers in other matters, besides making solutions. We are too much in the habit of talking of "lumps the size of horse beans." One soon can estimate weights and measures sufficiently for home use, but we must express weights, measures, and time in terms of known units to be of use to our neighbours.

Exposure Constants for Landscape Work in Fair Light.

Wet collodion (fir trees near at hand)	0.080	Iron developer.
" (viney in the open near)	0.011	Improved do.
Fothergill process (the mean of several)	0.400	
Collodio albumen	0.442	
Metagelatin (iron developed)	0.617	} Maxwell Lyte.
" (pyro developed)	2.467	
Albumen (a dull day)	1.04	Mr. Archer.
Tannin (fair light)	0.45	Mr. Sutton.
Tannin & honey "	0.049	Mr. Wharton Simpson.

An approximate exposure will be got by multiplying the constants by the square of the equivalent focal length of the lens, and dividing by the square of the diameter of the stop, both data being in terms of the same unit.—Yours truly,

AN AMATEUR IN INDIA.

July 27th, 1863.

Photographic Notes and Queries.

QUERIES ON GOLD TONING.

SIR,—Would you kindly give your readers a few words of explanation on the following matter, viz., the utility of *alkaline* salts in a toning bath. Presupposing the gold to be either neutral or neutralized, we have carbonate of soda, bicarbonate of soda, phosphate of soda, borax, or bichlorate of soda, acetate of soda, citrate of soda, carbonate of lime, chloride of lime, chloride of calcium, carbonate of potash, citric acid, and soda (the old ginger-beer process), and, perhaps, before the year is out, a host of others, all recommended by various operators, each having his favourite, and yet all "unstable as water." In fact, no dependence to be placed on any of them. Now, what I want to know is, why will not a *neutral bath* of chloride of gold and water *without any* of the foregoing preparations do, and do well? What is the virtue in each, or any of these salts, or a combination of two or more of them? Several firms are now advertising *neutral chloride of gold*—will it do *without these additions*?—if so, no greater boon can be conferred on the photographic public. I am tired of seeing gold becoming purple, and falling to the bottom. My opinion is that the best plan is to make a bath at the moment you want it—say, of soda and gold, which will answer for an hour or two. But the *use* of these salts in the bath is what I wish to know.—Yours,

AN OLD SUBSCRIBER.

P.S.—The great question is—If we can get a *neutral chloride of gold* in the market, is there any necessity for any addition?

[The object of the various alkaline additions to chloride of gold is to produce a certain decomposition, to destroy the feeble combination which exists between the gold and chlorine, so that the former may be deposited upon the print. If this decomposition were effected without any other base for which chlorine has affinity being present, the liberated chlorine would attack the silver in the print with great energy, producing meanness and excessive bleaching. If soda or a similar salt be in solution, the chlorine combines with it;

and although in virtue of its superior affinity for silver it will eventually combine to some extent with the latter, the action is controlled and regulated. If a solution of chloride of gold were perfectly neutralized with carbonate of soda, it would too readily be decomposed and would not keep, unless free chlorine were present. Hence a solution of chloride of gold neutralized by the addition of chlorineted lime will keep. The addition of acetate of soda and similar salts produces the required decomposition slowly, by the strong acid with gold displacing the weaker acetic acid and leaving it in solution with the neutralized, or partially neutralized, chloride of gold. As the colour of the print depends upon the size of the molecules of gold, and as the size is affected largely by the mode and rapidity of its reduction, different results are produced by different salts added, and by the proportions in which they are added. The plan you prefer of adding carbonate of soda to the chloride of gold often answers very well, but rarely produces the best results. It has, moreover, the disadvantages of producing meanness if used too soon, of not toning if not used soon enough, and of not keeping prepared for use.—Ed.]

CHEAP GLASS ROOMS.

SIR,—If Colonel Stuart Wortley would give, through the medium of your journal, a description of his cheap operating room, *i.e.*, the particular measurement, construction and conveniences, he would greatly favour many intending builders, as well as, sir, yours,

J. W. T.

Mirfield, September 5th, 1863.

INSENSITIVE SPOTS IN TANNIN PLATES.

SIR,—In your paper of the 28th August, I find your correspondent, "Tyro Tannin," in difficulties about insensitive spots in the negative. I have been troubled with the same, and it cannot be the gelatine, as I never use it, thinking I can get better pictures without it. I use only a line of black varnish round the plate before developing. I find in the centre of each spot a small speck, whether dust or not, I cannot say; but it appears to repel the tannin from it all round.

Inclosed is a specimen without gelatine for your inspection.—I am, sir, yours,
ANTI-GELATINE.
[The prints enclosed are very satisfactory.—Ed.]

LIME TONING.

SIR,—The lime toning question being one of the absorbing topics of the day in the photographic world, if you will kindly permit me to record my experience in that direction, the result may be of service to some of my brother amateurs in the art photographic. I, like many others, tried my hand at the different formulæ, given from time to time through the columns of the PHOTOGRAPHIC NEWS, with but little or no success; not that I ever had a *mealy* picture (and I may here remark that I have never had a *mealy* picture since I have used acetate of soda in my bath for the papers), but I found the *bleaching* spoiled all my best prints. After trying this, and trying that, at last I made a bath as follows:—

Beaufoy's concentrated chloride of lime	1/2	drachm
Acetate of soda	1	"
Chloride of gold (Hockin's)	2	grains
Distilled water	20	"

After mixing, I put a piece of common chalk into my stock bottle; in two days, my bath began to work. I enclose a print toned therein.—Yours obediently,

AN AMATEUR.

[The print enclosed is a very satisfactory one, and the tone excellent.—Ed.]

Talk in the Studio.

PHOTOGRAPHS OF GLACIERS.—The Austrian correspondent of the *Daily Telegraph* says:—"A photographic expedition started lately from Vienna for the Clockner, and the formidable glaciers surrounding the system of the Saltzburg and Tyrolese Alps. The enterprise has been hitherto crowned with signal success, and promises to yield a considerable number of faithful delineations of the upper world. Of the Clockner, eight different views have been taken at the height of 11,000 feet.

PHOTOZINCGRAPHY.—We see it is announced that the whole of Domesday Book, relating to thirty counties, has now been reproduced in fac-simile by photozincography, under the superintendence of Colonel James, at Southampton.

PRESENTATION-PRINT OF THE PHOTOGRAPHIC SOCIETY.—The members of the London Photographic Society are fortunate: for their next year's subscription they will become the possessors of a picture of at least the full intrinsic value of the money, and which will derive the added value derived from selectness, as its circulation will be confined exclusively to members of the Society. The picture is Robinson's charming composition, "Bringing Home the May." The society's *Journal* says:—"The presentation-print for next year will be one of the finest photographic pictures which have ever been issued. Many of our readers have seen, and all of them have heard of Mr. H. P. Robinson's last and finest composition, "Bringing Home the May," a picture which has won golden opinions from both French and English critics as the finest photographic composition-picture ever produced. The size of the original picture is about forty inches by fifteen inches, and it was published at twenty guineas. Notwithstanding the unprecedented price, Mr. Robinson received a large number of orders, which his other engagements did not permit him to fulfil. With a view to prevent disappointment, he resolved to issue it on a smaller scale, the size being about twenty inches by eight inches, and the price a guinea. The very fine negatives and copyright for this issue Mr. Robinson has handsomely presented to the Photographic Society, and each member for the coming year will receive a mounted copy with india-tinted margin. As the photograph will not be published in any other form, members of the society will have the exclusive possession of this picture."

MEAGHER'S CAMERA.—The magnificent camera presented by Mr. Meagher for the benefit of the Lancashire Fund, and which was declared by several of the jurors to be the finest camera in the International Exhibition, was drawn for a few days ago at Twickenham House, the residence of Dr. Diamond, Secretary of the Photographic Society, when we, with a few other members of the society, were present. The names of the subscribers, one hundred in number, had been entered in a book in the order of their subscription. One hundred slips of paper, in one of which the word *prize* was written, were placed in one hat, and one hundred slips numbered from 1 to 100 in another. The drawing was confided to two young ladies, who each drew a slip, coincidentally, from the two hats, and announced its contents. Eighty-seven blanks were drawn before the prize turned up; and when it did so, number 10 came at the same time. This was found, on examination, to be one of the numbers of two shares taken by Mr. William Brown, a mining engineer, now in Spain. Mr. Brown was one of the earliest collodion photographers, and a friend and associate of Mr. Archer's, and it is somewhat odd that he made with his own hands the first camera specially adapted for collodion plates. Shortly after the discovery of collodion he left England for the Australian Continent, Feegee, &c., only returning to Europe last year.

To Correspondents.

- X. Y. Z.**—Where the negative is intensified after it has been fixed and dried, it is important to use a collodion which adheres well to the plate. Where a tendency exists, however, for the film to leave the plate during intensifying it is desirable to paint the edge for about one-eighth of an inch with varnish. The late Mr. Lacy used to intensify all his negatives after drying; and when any tendency to loosen was manifested by the film, he gave it an edging of Huches's black varnish. 2. Blanchard's collodion may be intensified after fixing and drying with great advantage. 3. The Sahnce varnish is the hardest with which we are acquainted.
- P. C. J.**—Your pictures are very creditable for a photographer of only two months' practice. The greatest fault is in the lighting. You have too much diffused light, and it is too much in front. The consequence is a want of force and of good modelling. No. 5 is your best picture, but in it there are a few spots which look very like under-fixing, the hypo probably having been old and exhausted. Your background is too much cut by straight lines; especially avoid the light-coloured nondescript ornament to the left, which appears in each. There is some want of brilliancy in the prints, but it is chiefly due to the character of the negatives which lack a little force. Take care to avoid any deposit of the deep shadows. The acetate toning bath will probably give you, as a novice, the least trouble.
- R. SMITH.**—We have received the varnish, and will try it on the first opportunity we can command.
- W. COLESWORTH.**—The sitter placed with his back to the south, with the light from the north-east, falling obliquely on him, would answer very well. Mr. Rejlander states that he finds sufficient light in his glass room. But, remember, that it is in a fine position, with a large expanse of open light. We should, as a rule, recommend having the capability of getting a little more light. Mr. Rejlander's address is 7, St. George's Terrace, Maldon Road, Haverstock Hill; but we would suggest that the time of

professional photographers is generally very valuable, and it is scarcely fair to expect them to write private letters describing their arrangements, especially when they have already fully described them in print.

NORMA.—The only mode in which we see that you can reap any benefit from the discovery of a valuable dry process is by preparing the plates for sale. If you can prepare dry plates to be certain and rapid, they would doubtless sell. We shall be glad to receive your further promised communication.

OSK WHO IS GOING TO TRY THE DRY.—There is very great variety in the keeping qualities of plates, both before and after exposure. As a rule, it is desirable to develop as soon as possible after exposure. We have heard of tannin plates keeping a week or two after exposure without injury, and of collodio-albumen plates keeping longer still. But they should be carefully sealed from damp, &c., as well as light. Some plates spoil if not developed within a few hours of exposure, the image latent being gradually destroyed.

A.—The stains in your print are caused by hyposulphite of silver. How it came there is less certain. The spots have scarcely the appearance of those caused by imperfect fixation. They rather appear as though some trace of nitrate of silver had come into contact with the prints before the hypo had been removed. This would not necessarily show in an appreciable degree until they had been exposed to the light for some time, which might not occur until after they were mounted. The stain is in all respects characteristic of hyposulphite of silver. On wetting the spots and exposing them to sunlight, those which were faint and scarcely perceptible became very much darker, and had the dirty yellowish brown and mottled effect so commonly produced by the decomposition of hyposulphite of silver. 2. As photographs they are very good indeed. There is a little excess of top and front light, but, with this exception, they are excellent. 3. It is evident that your ether was not good. We have known the addition of had ether to collodion produce insensitiveness and fogging. It does not necessarily follow, however, that it was bad when sold to you: remember that ether, when kept in a partially filled bottle and in the light, becomes acid and unfit for photographic purposes. Your bath may be rectified by the addition of bicarbonate of soda until a slight permanent precipitate is formed; then expose to the sunlight for a few hours, filter and try. If necessary, then add a little acid. It will probably work all right.

A. B. C.—From our own experience, and the mass of evidence which comes under our attention, we should say decidedly No. 2.

P. M.—Some samples of paper have a much greater tendency to lose their tone in the hypo than others. When a sample is found to give this result the only plan is to tone a little longer before fixing. It is also most common with prints from weak negatives which do not admit of deep printing or bronzing of the shadows. It is possible that the vapour of coal tar in the dark room might cause fogging; but we do not see any objection to it for coating opaque parts of the studio.

HARRISON FRODSHAM.—Methylated spirit may be used in the developing solution without any disadvantage. 2. Common vinegar might be used instead of acetic acid in the developer, but its strength is very uncertain, and a large quantity would be required. 3. If common acetic acid be used instead of the glacial acid, a larger quantity must be used.

TYRO.—Volume VI. of the PHOTOGRAPHIC NEWS is unfortunately out of print.

THOMAS K. LANE wishes us to state that a print from a tannin plate of which we spoke highly in a recent number, was not printed by himself but by Mr. Warner, of Ross.

W. BARTHOLOMEW.—We are uncertain as to where you can obtain albumenized paper salted with barium. Mr. Lampray will prepare you some if you require a quantity. Mr. Enghand prepares his paper with half barium salt and half ammonium, but we do not know that it is for sale. Mr. Heisch (Murray and Heath) used at one time, we believe, to prepare a barium paper, but we do not know whether he does so now or not.

B. W. B.—The want of sharpness in your picture is due to the figure having moved very considerably. There has been a lateral movement of at least two inches in this case. It is also doubtful whether it was properly focussed. You appear to be exposing altogether too long. Two minutes' exposure at midday in fine weather seems monstrous. One-sixth of that time would be nearer the mark.

J. FOOTE.—Your prints are very good. The negatives are a little hard. A trifle longer exposure and less intensifying would have been better, but the prints are of good quality.

A. DEANY.—If you wish to albumenize your own paper, use 8 grains of chloride of ammonium to each fluid ounce of white of egg, very thoroughly beaten; and if you want a high surface do not add any water. 2. If your prints are carefully washed, before immersion in the toning bath, there ought not to be any precipitation. A black precipitate in the toning bath is probably metallic gold.

JOHN DAVIDSON.—We do not know any one in this country who sells micro-photographs mounted as charms. Should we hear of any one we will let you know.

J. CASARTELLI.—We will make some inquiry about the claims of Mr. Potter to the invention of Eden's camera, and probably insert your letter in our next.

R. T. BACH.—We will examine the glass, and report in our next.

C. M. SMART.—The silk appears to be perfectly non-actinic, but it obstructs a great deal of light.

Several Correspondents in our next.

Photographs Registered during the Past Week.

- MR. HENRY VINES**, Photographic Institution, Clifton, Bristol,
Two Photographs of the late Mrs. Slaughter.
Photograph of Jaues Holman, Esq., F.R.S., F.L.S., the celebrated Blind Traveller.
- MR. JAMES MC CORNICK**, 60, Park Street, Walsall, Staffordshire,
Photograph of Horatio Barnett, Esq.
- MR. A. S. WATSON**, 2, Regent Road, Yarnmouth,
Photograph of C. Camberlin, Esq.
- MR. GEO. EDWIN EWING**, 152, Hope Street, Glasgow.
Photograph of the late Lord Clyde, taken from marble bust.

THE PHOTOGRAPHIC NEWS.

Vol. VII. No. 264.—September 25, 1863.

CONTENTS.

	PAGE
Printing in America, Fuming, &c.....	457
Assaults in Photographic Studios	458
Mr. Blanchard's Manipulating Box	458
The Manufacture of Photographic Collodion. By W. L. Noverre	459
Jottings from the Note-Book of a "Photographer's Assistant."—	
No. II.....	460
Photo-Block Printing.—No. I. By Joseph Lewis.....	461
A Photographic Trouble. By C. W. Hull.....	462
The Economy of Toning. By J. H. Lawyer.....	462
A Short Lesson in Photography.—No. 15.....	462
Hints on Success and Failure in Printing	463

An Artist in Trouble.—Help Wanted.—Pinholes and Varnish.....	464
Correspondence.—Foreign Science—The Triple v. the Globe	
Lens, &c.—Formic Acid in the Developer—The Invention of	
the Triple Lens—Bad Glass Plates—Eden's Microscopic	
Camera	465
Photographic Notes and Queries—Image on the Retina of the	
Dead Eye—Gutta-serchia Negative Transfers—Nitrate of	
Soda in Albumenized Paper	467
Talk in the Studio	468
To Correspondents	468
Photographs Registered during the past Week	468

PRINTING IN AMERICA, FUMING, ETC.

THE system of treating excited albumenized paper with the fumes of ammonia which has been described in our pages in various extracts from American journals, has not obtained a permanent place in the practice of printing in this country. When it was first announced in our pages as the independent discovery of Mr. Penny, of Cheltenham, a few experimentalists gave the system a hasty trial, and condemned it. Others did not consider it worth a trial, and virtually the plan has been ignored or abandoned.

Nevertheless, we are by no means certain that the fuming system has received justice, or that to disregard it is quite wise. Let it be remembered that it is not a mere suggestion which has been tried on a small scale by a few enthusiastic or crchetty experimentalists. It is the method adopted not only by many of the ablest amateurs in America, but also in many of the largest professional establishments, and answers commercially. We have recently had an opportunity of conversing with a gentleman who was for some years manager of one of the branches of the photographic establishment of Fredericks and Co., one of the best reputed houses in New York. This gentleman, Mr. Cohner, is now principal of a large establishment in Havannah. He informed us that for the last three years, long before the reputed secret was published, he had practised the fuming system with all his prints, and was so thoroughly convinced of its advantages that nothing could induce him to give it up. To him it appeared that it was just the one thing required to give perfect excellence to many of the prints he saw in this country and in the cities of Europe he had recently visited.

The only mode in which he could explain to himself the apparent indifference on the subject which had been manifested in this country was by attributing it to some misapprehension of the real claims of the process which had, he thought, been a little mis-stated and misunderstood. He put forth but trifling claims for it on the score of superior sensitiveness or greater economy. It was on the higher quality of the result he insisted. The prints were out of all proportion richer, deeper, and more brilliant, and possessed perfect immunity in all cases from mealiness. The shadows of the prints produced upon fumed paper possess, he states, a velvety depth altogether unattainable by any other means. And the extra labour and trouble when once the arrangements were made and the system brought into working order was altogether insignificant. Neither were the fumes of ammonia in the printing-room found at all injurious, although at the outset formidable annoyance had been anticipated.

The system of printing adopted was as follows:—The fuming box consisted of a large deal chest, which had originally been a packing case, of about thirty inches or three feet square. This was papered at all the cracks and joints to make it tolerably air-tight. A saucer containing about an ounce of strong liquid ammonia, covered lightly with cotton wool to diffuse the fumes, was placed at the bottom. A

dozen whole sheets of paper were suspended upon wooden rods above the ammonia, and the lid was then closed for about fifteen minutes. The nitrate bath contained sixty grains to the ounce; half of it was converted into ammonio-nitrate of silver by the ordinary method of precipitating with ammonia and then adding ammonia until the precipitate was redissolved. This ammonio-nitrate solution was then added to the other half of ordinary nitrate solution. A slight precipitate of oxide of silver was thus caused, which was allowed to subside and remain in the bottle. The paper was excited on this bath for just one minute. When dry, but not until quite dry, it was fumed as we have described. The effect of the fuming is to make the paper rapidly discolour, sometimes reaching a cream tint during the operation and a buff colour in an hour or two; but this discoloration does not, in the slightest degree, affect the purity of the finished print.

The exposure may possibly be a trifle shorter, Mr. Cohner observed, than by the ordinary method, but not sufficiently so to have excited his attention. The appearance of the print is, however, very different. Even with thin, poor negatives, the shadows rapidly bronze and acquire a depth of reduction without overdoing the lights, which ensures richness and vigour in the finished print. The printing in his establishment is carried tolerably deep, and the prints are well washed before toning.

The toning both is made as follows:—

Chloride of gold	1 grain.
Chloride of lime	1 "
Water	4 ounces.

This solution is allowed to stand twenty-four hours, and is then ready for use. The tones are rich and deep, but warm, and, for the majority of subjects, have the most satisfactory effect; but where pure black tones are required, half a grain of nitrate of uranium is added for each grain of chloride of gold. With this addition the most perfect black tones, like those of engraving, are secured. The fixing and washing are conducted in the usual manner.

It happened unfortunately that we were not at home when Mr. Cohner first called upon us, introduced by Mr. Anthony, of New York. He then proceeded to visit various cities in continental Europe, and before he returned to London, on his way back to Havannah, he had parted with every specimen of American photography which he had brought over, so that we cannot add to his description of these results the indorsement derived from inspection. But we are familiar with the excellent printing of many American photographers; and we have seen prints from Messrs. Fredericks, where the same system is pursued, of unusual excellence. The fact, moreover, that this fuming system is used in large commercial establishments, amongst a people so pre-eminently practical and labour-saving as the Americans, speaks volumes in its favour. They are especially free from the fetters of custom or habit, nothing is likely to obtain general practice amongst them, unless it be followed by essentially and

tangibly beneficial results. And for these and similar reasons we are led to suspect that the system in question has not yet received in this country a sufficiently fair trial, and that it may yet repay further, fuller, and more careful experiments.

The specimens of printing we frequently see are far from being perfectly satisfactory, especially when the negatives are thin or veiled. And as imperfect negatives must often be printed, a method which will ensure more brilliant prints is of great importance. As a correspondent remarked in a recent letter, good negatives will yield good prints by almost any process, what is required is a method of obtaining moderately fine prints from indifferent negatives. For this purpose, at least, the fuming is worth trying.

ASSAULTS IN PHOTOGRAPHIC STUDIOS.

PHOTOGRAPHY is in some respects unfortunate. Because black sheep have occasionally been detected, there are some people who think themselves justified in referring to the whole flock as tainted. In times, we trust entirely gone by, when the cheap dens were much more common than they are now, quarrels about the price of the shabby production were not quite uncommon, and occasionally quarrels led to assaults. We are glad to believe that the assaults, and the occasions which led to them, are now much less common than they were, if they are not entirely removed. But with indiscriminating people the stigma still sticks, and it is felt to be a safe thing to sneer at photographers and photographic studios. A letter, which appeared in the *Daily Telegraph* a few days ago, is an illustration of this. It is as follows:—

"PHOTOGRAPHIC ROOMS.

"TO THE EDITOR OF THE 'DAILY TELEGRAPH.'

"SIR,—The press will do well to caution ladies against going alone to a photographic studio, as it is called. A young relative of mine, who has considerable personal attractions, went a few days since, without any attendant, to a photographer in the Western Central district, to have her portrait taken, and when she entered the room the photographer sent his son out of it, locked the door, and, without saying a word to the young lady in question, kissed her, and attempted to take her to a sofa. She, however, cried out, and told him that she would scream 'Murder,' if he did not desist. This, as his wife was within hearing, alarmed him, and he unlocked the door, out of which my young relative immediately rushed.—I am, sir, yours, &c.,
"SENEX.

"September 18."

Now, assuming this story to be in all particulars true and unexaggerated, it should surely have occurred to "Senex," if age had brought the discretion which belongs to it, that it was a case for the police-court, where suitable punishment would have reached the individual offender, rather than for conveying a general inuendo against an entire profession. A teacher of writing was recently severely punished for taking a similar liberty with a pupil. But is it fair?—is it reasonable?—is it to be tolerated?—that because a profession has unfortunately been disgraced by one scoundrel, that the stigma is to rest on all, and a general caution should be issued warning ladies against trusting themselves in their power? Ladies have been swindled occasionally in a draper's shop. Acting on the advice of "Senex," they should never trust themselves in a draper's establishment without an efficient guard; and, especially, should they never trust themselves alone in the establishment of a dentist, a teacher of music, of drawing, of writing, or of any other art, simply because in these professions there may have been blackguards, who have forgotten that the more unprotected a woman, the greater demands she possesses upon chivalry. Photographers know well, sometimes to their serious cost in wasted time, that ladies generally do visit

their establishments in companies, and it is sometimes absolutely necessary to place a prohibition upon any one but the sitter entering the studio, in order to avoid interference or distraction of attention. In other cases it will happen that if a lady may not go without company, she cannot go at the time which suits her at all. In these and a variety of other cases the unreasonable and sweeping advice of "Senex" would, if followed, be very injurious.

The unfairness of the general stigma has been felt by many photographers, and finds expression in the following, which appeared in the *Telegraph* a day or two afterwards:—

"TO THE EDITOR OF THE 'DAILY TELEGRAPH.'

"SIR,—We think it only fair towards respectable photographic establishments that your correspondent 'Senex' should state the exact locality of the place where his relative was treated so disgracefully. To only mention the postal district leaves a number of other establishments open to suspicion; and in fairness to ourselves and the public, we have, we think, a right to demand that your correspondent should be explicit, and state publicly the address, if not the name, of the offending person.—We are, sir, yours, &c.,

"THE PROPRIETORS OF VARIOUS PHOTOGRAPHIC ESTABLISHMENTS IN LONDON.

"September 21."

"Senex" as yet has made no sign in answer to this letter. Should he fail to give the due publicity to the name of the offender, or point out his residence, the legitimate conclusion will be that he has given publicity to an exaggerated if not a fabricated and euluminous statement.

MR. BLANCHARD'S MANIPULATING BOX.

We have frequently been asked by readers to describe the tents or portable laboratories used by different professional photographers who have distinguished themselves by open-air photography. These differ according to the tastes and necessities of the operators. Mr. Bedford has a carriage fitted up as a dark room. For London street work, Mr. Blanchard frequently uses a cab, its windows covered with yellow calico. Mr. Wilson uses a very primitive and simple tent. Except for London streets, Mr. Blanchard uses a dark-box, or manipulating chamber, which does not envelope the head, and the majority of his fine instantaneous pictures have been produced in it. Mr. Samuel Fry uses one of very similar construction. As Mr. Blanchard's box is especially distinguished by simplicity, portability, and convenience, we have asked him to describe it for the benefit of our readers. We may add that whilst Mr. Blanchard has not placed any prohibitions, by registration or otherwise, upon photographers making it for themselves, and by his description affords them every facility for doing so, for those who do not wish to take the trouble it may be interesting to know that it is manufactured for sale by Mr. C. E. Elliott, under Mr. Blanchard's instructions. Here is the description:—

"MY DEAR SIR.—In compliance with your request, I have sent you a description of my dark box, and trust it may prove of service to some of the readers of the *PHOTOGRAPHIC NEWS*. Some years ago I used to bag up my head when away from home, but too frequently I found myself quite abroad in my operations. Since, however, I employed my dark box I find my labours much simplified. It is quickly put up and taken down, and when packed is quite a compact affair, quite as easy to carry as a portmanteau. The bath, washing tray, tank, holding half a gallon of water, and into which all the chemicals necessary for a day's operations, snugly pack without fear of breakage, cloths, and box large enough to carry twenty-four plates $8\frac{1}{2} \times 6\frac{1}{2}$, all packed inside. Indeed, I carry everything except camera and legs, in the box. I have trudged many miles with the camera, strapped to the legs, slung across the shoulder, and the dark box like a portmanteau in the other

hand, for I always hold it a grand thing in out-door photography, as in matters political, to be independent of foreign aid.

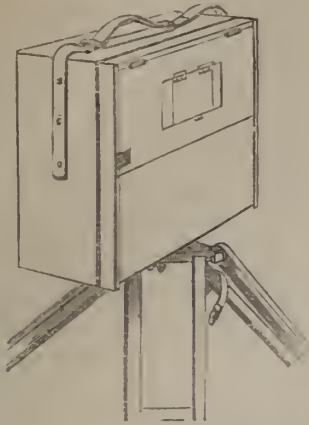

"The box I regularly employ is 20 inches long, 7 inches broad when closed, and 14 inches high, outside measurement. It opens in the side, and is divided in the middle—one-half drops down and the other is raised up. The doors are held

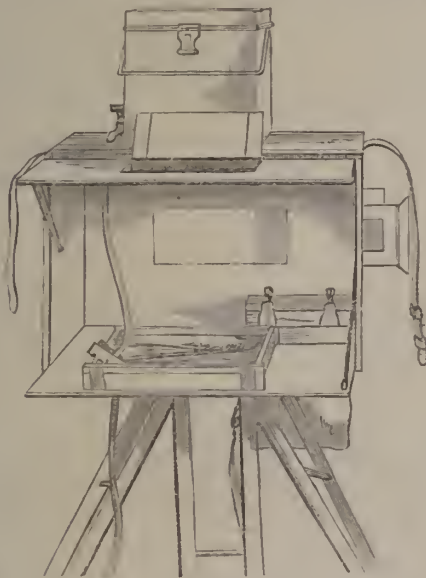

in place by knee joints. When open for work the box forms a dark chamber 20 inches by 14 inches. A hood comes over the open part, in which are two sleeves for the arms. There is a window in the back, glazed with yellow glass, which slides open, and through which the plates and dark slides are passed. When not in use a shutter closes and effectually protects the yellow glass from injury. In the top lid is also a window similarly protected, through which the operator watches the development of the picture. The tank is placed on the top, with a pipe coming through the box, so that no room is taken up unnecessarily inside. The tray to catch the water during the operations of development and fixing, is a folding one, with a pipe going through the box to carry off the waste water clear of the feet of the manipulator. The bath is placed in one corner of the box, but facing the window. When developing, I stand the dark slide in front of the bath, so that no developing solution can by accident be splashed into it. I think this box will be found to be as portable and, at the same time, as convenient as anything yet described, for, when open for operations, it is just twice as large as when packed, and

when everything required for a day's operations is safely stowed away, the box is as easily carried in one hand as

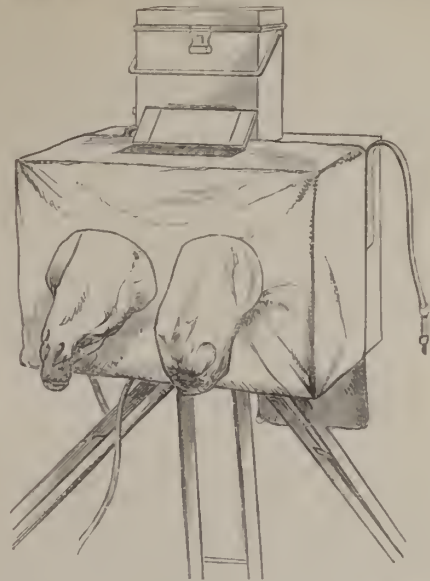

a carpet-bag. I may add the box is now manufactured for sale by Mr. C. E. Elliott, and those who fear the trouble or risk of making one, can get it from him at a price as low as would be charged by any carpenter."

VALENTINE BLANCHARD.

THE MANUFACTURE OF PHOTOGRAPHIC COLLODION.*

BY W. L. NOVERRE.

HAVING prepared our pyroxylic by the formula given, we will next consider the chemicals required for making collodion from it, viz., the ether and alcohol in which it has to be dissolved, and the iodides and bromides which are to be mixed with the solution.

ALCOHOL.

There are two kinds of alcohol met with in commerce, pure and methylated; the latter is ordinary spirit with 10 per cent. of wood naphtha added to it, this is issued free of duty, being rendered unfit for human consumption by the addition of the wood spirit which communicates to it a very unpleasant taste and odour, but does not interfere with its employment for many chemical operations or in the arts, while it can be obtained at half the price of pure spirit. The strength of both kinds of alcohol varies according to the method of preparing them, it is convenient to have two kinds—rectified spirit, sp. gr. .820, and a stronger quality sp. gr. .796 to .800; by varying the proportions of these a spirit of any strength we require may be obtained. A few words may be said about the preparation of alcohol, that persons unable to purchase a suitable quality may know how to make it. Ordinary spirit of wine may be prepared by gently distilling brandy, rum, arrack, or other spirit in an ordinary still, stopping the operation when the spirit which comes over is found to be too much diluted with water, this can be ascertained by tasting it, or more accurately by taking its specific gravity; in order to obtain alcohol sp. gr. .820 from this spirit, it must be shaken up in a bottle with powdered carbonate of potash or pearl ash, thoroughly dried in an iron pan over the fire; when the salt has mixed thoroughly with the liquid, it may be put aside till the mixture of potash and water has subsided, when the alcohol

* Continued from p. 451.

may be drawn off, and the operation repeated with fresh potash till the salt can be shaken about in the liquid without being wetted, the spirit may then be distilled to free it from any impurities in the potash that may have dissolved in it. If it is intended to distil it off chloride of calcium or lime, this will not be requisite. To make alcohol sp. gr. '805, the last named spirit must be distilled at a gentle heat off fused chloride of calcium, six ounces of the salt being mixed with a quart of alcohol, sp. gr. '820, in a still; as soon as the chloride has dissolved, apply heat, and allow the spirit to distil over slowly. The first portions that come over will be the strongest; it will be safer to leave a few ounces in the still, as the last portions will be weak if the distillation is carried too far, it will also prevent the residue from setting in a hard mass at the bottom of the still; the residue may be poured out after the operation into a shallow iron pan, and evaporated to dryness over a fire, when it will be fit for a future operation. The specific gravity of absolute alcohol is '794, but it is seldom met with of this strength, being more generally '796; it may be made by distilling spirit, sp. gr. '820, with half its weight of quicklime. The lime is broken up small, and placed in a still with the spirit. It is then loosely corked, and left for two or three days, till the lime appears slaked; the alcohol is then distilled; a strong heat will be required towards the end of the operation. For distilling spirit off chloride of calcium or quicklime, an ordinary still would be unsuitable, as the joints do not fit sufficiently close. Philips's still, manufactured by Messrs. Jackson and Townson, is perfectly air-tight and admirably adapted for the purpose.

Many have objected to the use of methylated alcohol and ether in the manufacture of collodion. Amongst other objections, it has been urged that the bath will gradually become injured; there appear, however, no grounds for this idea. A bath which has been in constant use for more than a year, with collodion made from methylated spirits, is still in perfect working order: the quantity of ether and alcohol that has accumulated in it causes the film to dry rather quickly, and makes it rather difficult to get the developer evenly over the plate when it has been kept long between sensitizing and development; but it works cleanly, and free from spots. In order to be positive that the presence of methylated spirit in the bath had no effect on the sensitiveness of the plates, this bath has been tried side by side with a new bath prepared on purpose.

Collodion prepared from methylated spirits will, perhaps, decompose a little more rapidly after iodizing than that prepared with pure ether and alcohol. This is not shown by liberation of free iodine but by the collodion yielding rather a rotten film and an intense image. Much will, of course, depend on the nature of the iodide employed, the quantity of bromide, the purity of the pyroxyline, the age of the ether, and the temperature in which the collodion is kept. Collodion prepared with good methylated ether and alcohol, bromo-iodized with equal parts of iodide of ammonium and cadmium, with half a grain of bromide per ounce, has been kept without deterioration for six months during the summer, and would probably keep much longer. Methylated alcohol is sold of three kinds—the ordinary spirit, sp. gr. '820; the so-called absolute having a sp. gr. '796; and a third kind, which is allowed to be sold by unlicensed dealers, containing a small quantity of shellac, being intended for varnishes and burning in lamps, &c., it is quite unsuited for photographic purposes. The presence of the impurity may be detected by adding a few drops of water to the spirit, which renders it milky by the separation of the lac, which is insoluble in water. Methylated spirit which has been long kept acquires a much stronger smell than that freshly distilled. The specific gravity of methylated spirits is deceptive on account of the wood spirit it contains, the specific gravity of that substance being '798.

ETHER.

There are two kinds of ether, pure and methylated. The

specific gravity of ether prepared from methylated spirit is less than that of pure ether prepared by a similar process. The specific gravity of ordinary pure ether is '750, and of methylated '730; a stronger kind of pure ether can be obtained, having a specific gravity '725. Either of these are suitable for collodion, but care should be taken to obtain a sample by a good maker, as, if the process is not conducted with proper care, the ether is liable to be contaminated with impurities, which injure the keeping properties of the collodion. The remarks made on the employment of methylated alcohol in collodion apply equally to the use of methylated ether. Ether is an unstable substance, by keeping and by exposure to the air or to light it becomes ozonized, in which state it liberates iodine from iodized collodion. Ether from methylated spirit is more unstable than pure ether, owing to the presence of methylic ether, which absorbs oxygen more readily; it is, probably, this substance that makes collodion prepared with methylated less stable than that made with pure ether, and it is not unlikely that collodion made from pure ether and methylated alcohol would be quite as stable as that prepared with pure alcohol and ether: those persons who consider methylated spirits unfit for making collodion have, probably, used a greater proportion of ether than alcohol in their experiments, thus introducing a larger quantity of the objectionable substance into the collodion. In the experiments described in this paper the proportion of ether has never been more than half that of the alcohol. The fumes of ether must on no account be allowed to come near the flame of a candle, as they are highly inflammable; and the distillation of ether should not be attempted, except with proper apparatus, and by a person accustomed to chemical operations, as serious accidents are likely to result.

Alcohol and ether, pure and methylated, of the specific gravities above named, as well as the acids of proper strength, together with the other chemical apparatus and chemicals required, may be obtained of Messrs. Jackson and Townson, 89, Bishopsgate Street Within.

(To be continued.)

JOTTINGS FROM THE NOTE-BOOK OF A "PHOTOGRAPHER'S ASSISTANT."

No. II.

PRINTING AND TONING DIFFICULTIES.

IS entering once more on the difficulties which characterise our printing operations, anxiety to throw a little additional light on that perplexing subject must plead an excuse for our temerity in venturing again on what may be deemed a threadbare topic. We admit much has been written, and manifold have been the arguments advanced in favour of this or that system proposed, but the humorously poetical laments of Cha-meal-eon, the doleful complaining of others, and the plaintive appeals made by the many—all these prove that we are nearly as far off from real success as ever. True it is, in the hands of the few certain formulas have yielded results that seem to approach perfection; but whilst the few have succeeded, others with apparently the same description of material, and in reality an equal amount of manipulative skill, they, in practising on the same formulas, have met with temper-trying failures, giving room to those who by chance have succeeded to plume themselves on their superior abilities. Now, we venture unreservedly to assert that if each party exchanged materials success and failure would change sides at the same time, because the formulas are founded on the results of experiments entered into with chemical compounds whose accidental properties are so variable that no two samples from the hands of different makers can be declared identical in their constitution. Now, if our printing operations were conducted on principles based on well-defined and thoroughly understood laws, the control over accidental disturbances which interfere with the proper working of the solutions might easily be

attained, as one or two experiments would be sufficient to determine their character. As an illustration, we may point to practical mechanics; this science, theoretically speaking, admits of no influence but which friction and other causes are known to exercise, because, being accidental, their retarding power can only be determined by experiment. As with mechanics, so in photographic operations, chemical laws are as undeviating as those that govern the mechanical powers, and in a theoretical view the same rule which applies to foreign causes may be observed; but in practice, if results are rendered unsatisfactory by the accidental elements set at liberty when the compounds are subjected to the solvent influence of water, then carefully conducted experiment, aided by intelligent observation, must determine the character of the interfering agent; but if the nature of that which is unchangeable is not understood, any attempts we may make to improve matters must of necessity be empirical, and chance must govern results, and to this blind reliance on chance are we indebted for the thousand and one perplexities that retard the progress of our art.

Without further remarks by way of preface, we now commence the subject before us, which we enter upon with a sincere hope that the suggestions and arguments we intend offering will prove a stepping stone, by the aid of which all hitherto unsuccessful ones may be enabled to surmount their difficulties. The subject will be discussed in the following order:—

1. The conditions required in photographic papers.
2. The unscientific and expensively wasteful means adopted for producing what is erroneously termed coagulation of the albumen.
3. The influence exercised by the presence of free acid in our toning solutions.

Our knowledge of the conditions required in photographic papers appears to have remained just where Mr. Hardwich left it. Had that gentleman continued with us, his rare penetrative genius would long ere this have devised means to banish meanness for ever; but photographers, generally, regard printing operations as purely mechanical, and, as such, they entrust this department to assistants, who come in for a full allowance of grumbling when failures occur; whilst the last-named class find a ready excuse by abusing the paper, which, like the kitchen cat, is often blamed for faults that belong to the fault finder. In the year 1861 an attempt was made to induce the paper manufacturers to undertake a series of experiments in order that a better material might be produced. The results of their labours is briefly told in the NEWS ALMANAC for 1862. "They have turned out miserable failures." Were they to blame for their ill success? Not at all. We set men to work to provide remedies, without affording any reliable information respecting the true cause of the evil which was erroneously attributed to the sizing employed in the manufacture of paper, and a lot of scientific nonsense about saponified size and acid size was produced to guide them in their researches. But, as size of some sort is absolutely necessary, and none better suited for the purpose could be obtained, the matter was allowed to drop, whilst grumbling continued with unabated vigour. If as much time had been employed in patient observation as has been consumed in finding fault the difficulty must long since have passed away, for it would have been discovered that the sizing which paper contains exercises no influence whatever in the production of meanness. Incorporated with the fibres, it binds them together, thus modifying the absorptive tendencies which render papers unfit for writing or photographic purposes. In plain salted paper printing, or with paper slightly albumenized, the size, doubtless, contributes its share of influence, because, under those conditions, the silver, obeying the laws of chemical affinity, unites itself to the organic matter—access to which is readily gained by the open pores—but the fact that plain or very slightly albumenized papers are not liable to meanness proves that the sizing has no part in the production of the evil. On the contrary, for

if the silver, under all circumstances, could associate itself with the sized fibres of the paper, and when exposed to light reduction was effected to the same depth, no amount of bleaching would produce meanness. When one layer was removed, another of the same kind and colour would offer itself to the biting influence of the bleaching agent, and this reduction might continue until the albumen coating was entirely eaten away, and still those white, grain-like spots would not make their appearance until the fibre itself was divided, except, indeed, the oft-repeated theory be correct, which accounts for meanness by attributing its cause to free chlorine entering into combination with the reduced silver, thus forming anew a white chloride of the metal. But this explanation, reasonable as it may appear, cannot be supported by evidence, as the following remark will prove. If meanness owed its existence to this cause, then would the disease be discovered in every print that had been subjected to toning action, no matter whether printed on plain or any other kind of paper; in a word, where reduced silver is found there would the white chloride be formed, because no gold toning solution exists that is free from liberated chlorine, that is to say, if the bath is in working order; but this topic will be more fully entered into in our "Jottings on Toning." Then admitting that our views on the cause of meanness are correct, what are the required conditions to produce even toning? Why, simply a surface that is perfectly smooth and evenly coated with pure albumen, so that the reduced silver may be of an equal thickness throughout, for the impermeable properties possessed by albumen (in our opinion) do no admit the decomposed nitrate salt to any more than an infinitesimal depth, but slight as the distance might be, the prominent fibres of the paper prevent the existence of the necessary conditions, except the bleaching power is reduced to the smallest compass. Mr. Sutton's india-rubber paper is the nearest approach to perfection we have yet seen, but there has been a mistake made in the albumenizing that renders much of it useless when exposed to ordinary treatment. The nature of the error will be pointed out in our next paper. We cannot conclude the present jotting without giving expression to a belief that if paper manufacturers would accept our suggestion as a basis for further experiment their well-known skill would soon enable them to place into the hands of photographers an article which would rid their vocabulary of the dreaded term meanness; and whilst conferring a boon on society generally, their own exchequer would be largely benefited by the introduced improvement. The views alluded to were fully explained in our paper, headed "An Attempt to Produce Even Toning."

PHOTO-BLOCK PRINTING.

No I.

BY JOSEPH LEWIS.

THE process of obtaining a raised printing surface by means of a coating of bichromate of potash and gelatine has now been several years before the public, but we have not had the pleasure to know of its complete success. My experience in the matter has taught me in this, as in other kindred processes, the more direct we are in our manipulations the better will be the result. Herr P. Pretch and others agree that the coating of gelatine should be quite dry and hard, and that the swelling up of the impression should be accomplished *after* exposure, and in this, I think, lies a cause of imperfect results. I use a mixture of gelatine and glycerine with the bichromate, similar to that described in my second article on photolithography, page 414. I do not allow the film to become completely dry, therefore the action of the light takes place at once and the resultant effect may be watched by having the negative suitably hinged so as to raise it up occasionally and shut it down with accuracy. I can thereby time the exposure until the lines are sunk low enough to yield an electrotype fit for printing. The action

of the light is of a twofold nature; while it renders the film waterproof it exercises the valuable property of contracting or shrinking the film in the most complete manner, so that on removal of the sensitive film from under the negative it is ready for casting from at once, and the sooner it is done the better.

A PHOTOGRAPHIC TROUBLE.

BY C. W. HULL.*

Why is it, good Mr. Editor, that all the photos in the land sit love mystery; so seek after complications which they do not understand, rather than aim to reduce our beautiful science (though some call it an art) to some simple and uniform practice? Mankind is naturally prone to mystify and make much out of little, to pretend to great knowledge and excellence through roundabout paths, believing as a rule that they excel just in proportion to their ability to confuse.

You will wonder why this homily is read to photographers; but you would not, had you been present at a late meeting of the Photographical Society and had listened to the thousand and one different ways suggested to produce good prints. One person said good prints could only be made by floating on a *hundred-grain bath for five minutes*; another thought forty grains was enough, and float two minutes, but he would add a *little nitric acid*, and a *little ammonia*, quantity not important, so that it was *not too much*. Another had worked to his satisfaction by dissolving oxide of silver in nitrate of ammonia, and he had to use only five grains to the ounce. Another did not believe any such solution could be made, and so on.

I beg to inquire if the heathens had any gods of Photography; if so, let us implore them to step in and save us or we'll all go mad. So much for the silver bath; now how to tone.

It is scarce worth while to speak of it, for no conclusion was arrived at. One could not get tones unless he used nitrate of uranium; another must have the chloride; another wanted acetate of soda, and another a saturated solution of phosphate of soda; and another a pinch of salt—a little citric acid—a little chloride of lime—and how many more salts and chlorides your correspondent knows not. He has a good memory for most things, but it is not equal to photographic formulae.

After everybody had had his "say" but to disagree, a few prints, the production of one of our best amateurs, Mr. J. M. Masterton, were shown, and all agreed that nothing was wanting in tone or finish to make them equal to the best; and better still, they were produced by a simple process familiar to all. No legerdemain, no half dozen ingredients in bath to sensitize, tone or fix. Paper floated on plain bath of nitrate of silver, 70 to 80 grains, fumed by the very much abused ammonia, which confuses so many, toned in gold made faintly alkaline with carbonate of soda, and fixed in plain hypo. If this was not a "settler" to complicated processes, it should have been; but I fear it was not.

Photographers should bear in mind one thing, and from it they can learn if they will, why it is that one man's prints so far excel another's. It is that one makes good clear and brilliant negatives, while another has thin and foggy ones. The last named has bad prints;—lays his difficulty on his printing experiments, gets "no better fast," and concludes the first has some great secret.

The best prints come only from him who makes the best negatives. This is the corner stone of photography, and the man who so works will succeed and never till he does.

THE ECONOMY OF TONING.

BY J. H. LAWYER.†

In using the gold toning bath much economy may be realised in its preparation. It is evident to the writer, from experiments recently made, that no part of the gold used in toning is exhausted, except what mechanically adheres to the prints on their removal from the toning bath; it follows that the quantity of solution used is very important as regards the economy of the operation. It is evident to the writer that the gold bath will tone prints so long as the

action of alkaline soda continues upon auro-chloride of gold, and that when the gold solution becomes thoroughly alkaline the toning properties of the bath cease. Therefore to tone two hundred prints it is only necessary to make up a bath of ten ounces to perform the work if only sufficient carbonate be added to tone moderately at first, and prolong the action of the bath until all the prints can be immersed in it.

The action of a small quantity of solution properly mixed may be as prolonged as that of a larger quantity. In fact, no amount of solution will tone longer or more than another, except as the action of the soda upon the gold is prolonged or hastened. When that action ceases the bath will tone no more in its present state, and if it be immediately precipitated, it will be found to have lost none of its gold except what adheres mechanically to the prints in removing them from the bath. Seven-eighths of the gold originally used will be still found in the solution, and may be precipitated from it by means of sulphate of iron or sulphuret of potash.

A SHORT LESSON IN PHOTOGRAPHY.—No. 15.*

In my last lesson I gave you the method pursued in the preparation of sensitized albumen plates for negatives, and observed, I believe, that some of the finest stereographs in existence were made on such plates. These transparent positives by Ferrier, of scenery in Egypt and elsewhere, are unsurpassed for softness, sharpness, transparency, and richness of tone. It seems to me to be a pity that more attention has not been bestowed on manipulations with albumen, so as to obtain a more sensitive surface; for the albumen film possesses some advantages over the collodion film for photographic purposes: it is much less destructible, because when dry it is very hard; it is very thin and transparent and can scarcely be distinguished from the glass on which it has indurated; it requires no varnish; it mixes freely with the iodides and bromides; it is not subject to that peculiar decomposition to which pyroxyline is prone. Its disadvantages are the difficulty of obtaining a uniform film and of drying it quickly, also of operating with it in the *wet state*. If means can be devised to use it in the latter condition I think it will be *superior* to collodion.

I will now proceed to another process, called the Taupenet process, from its having been originally proposed by this French gentleman. This design was to combine the advantages of these two ingredients, albumen and collodion. The collodion film on the glass is a much better receptacle of the albumen than the glass itself; but the operation is somewhat circuitous, inasmuch as the plate is sensitized twice. Other methods have since been devised in which the collodio-albumen film requires but one sensitization. Some of these are found to be very effectual dry processes.

Preparation of the Glass Plates.

These are first immersed for a number of hours in the following solution:—

Salts of tartar	1 ounce
Rain water	16 ounces.

If the plates have been already employed before, soak them in water and remove the collodion film with a piece of rag. The alkaline solution can be used several times. As soon as the plates are removed from this solution, pass them through water several times and then clean and polish them in the vice by means of alcohol and rotten stone as directed in some of my preceding instructions. Immediately before the collodion is flowed upon the plate, it is dusted with a silk cloth and then with a broad camel's-hair pencil. A collodion that flows well and one that adheres forcibly to the glass is to be preferred.

* Amateur Photographic Print.

† The American Journal of Photography.

* From Humphrey's Journal.

Formula for the Collodion.

Concentrated ether	12 ounces
Alcohol	3 ounces
Pyroxyline	1 drachm
Iodide of ammonium	1 drachm
Bromide of ammonium	15 grains.

The collodion, containing quite an excess of ether which is very volatile, has to be poured over the plate with great dexterity. It is very fluid, and admits of this dexterity. The plate is then, as soon as the film has sufficiently congealed, immersed in the ordinary nitrate of silver bath containing about 35 grains of the nitrate to the ounce of distilled water. It is left in this bath for four or five minutes, and then taken out and allowed to drain. After this proceeding the plate is immersed in a dish of rain water and well washed by agitation, or it may be washed at the tap by the ordinary method, and then flowed with distilled water several times and again allowed to drain. It is next flowed, whilst still moist, with the following albuminous preparation :

The white of eggs (free from germs and yolk)	12 ounces
Distilled water	2 ounces
Iodide of ammonium	44 grains
Bromide of ammonium	16 grains
Ammonia	1 ounce
White sugar	2 drachms.

These ingredients are intimately mixed by an egg-beater until the mass is reduced to froth. They are then allowed to subside for a day or two. The clean part is separated by decantation or by a syringe from the residue below and from the indurated scum on its surface above. With this clear solution flow the still moist plate as you would with collodion almost. Holding the plate by the left hand nearer corner between the thumb and the first finger, pour the albumen on the right hand further corner; then, inclining the plate, let the albumen flow to the left hand further corner. Now allow the whole body of the albumen to flow down in one mass, driving the water before it until it arrives at the nearest edge. Inclining the right hand nearest corner, allow the water to flow off together with the excess of surplus of the albumen into a separate receiver. Now raise the nearest edge of the plate and let the surplus proceed back again to its place of starting, and once more to the nearest right hand corner, when all excess is allowed to flow off. The plates are then reared away on one corner to dry. In this state the film is not sensitive, and consequently the plates so far can be prepared beforehand and preserved until wanted.

Sensitizing of the Taupenot Plates.

The plates are immersed in this bath with great care and dexterity in order to avoid all lines of stoppage, &c. In thirty seconds the film will be sufficiently sensitized. The plate is then taken out and plunged into a dish of water, moved about in this, then transferred to another, allowed to drain, finally flowed two or three times with distilled water and put away to dry in a perfectly dry place.

In this condition the film is much more sensitive to light than albumen alone, although it is less so than collodion. The plates can be preserved sensitive for several months, but the sensitiveness gradually deteriorates by age.

Exposure.

With a portrait combination an exposure of two or three seconds will be found to be sufficient to receive a good impression of an object well illumined by the sun, and as many minutes will suffice with a single lens.

Development of the Image.

The developing solution is composed as follows :—

Distilled water	12 ounces
Gallie acid	18 grains
Pyrogallie acid	6 grains
Alcohol	2 drachms
Acetic acid	½ drachm.

To every three ounces of this solution add a solution of nitrate of silver when about to use it. A larger proportion of pyrogallie acid will increase the intensity of the blacks; and, where the time of exposure has been too long, the gallic acid may be diminished and the acetic acid increased. The horizontal bath is preferable for this sort of development. The plate, first dipped in water, is then lowered dexterously, with the collodio-albumen surface downwards, into the solution; and the upper end is allowed to rest on a piece of glass or porcelain to prevent the film from coming in contact with the bottom of the vessel.

The plate is raised from time to time to watch the progress of the development, which may occupy from ten minutes to twenty-four hours. When the shades are intense enough, the plate is taken out, well washed, and then immersed in the fixing solution.

Fixation of the Taupenot Plates.

Hyposulphite of soda	1 ounce
Water	20 ounces.

Even a weaker solution will frequently be all that is required. The soluble iodides being removed, the plates are taken out and thoroughly washed as usual.

Modified Albumen Process. By James Larpey.

Let the plates be coated with any collodion, iodized or non-iodized, and afterwards well washed.

Now flow them with the albumenizing solution, which is made as follows :—

Formula for Iodized Albumen.

Albumen	10 ounces
Iodide of ammonium	50 grains
Bromide of potassium	12 grains
Water	2½ ounces.

The mode of flowing is the same as already described for the Taupenot process. After draining, dry as before indicated.

Sensitizing Solution.

Nitrate of silver	60 grains
Acetic acid	60 minims (1 drachm)
Water	1 ounce.

The time required will be thirty seconds or thereabouts; remove from the bath and wash thoroughly.

Exposure.

This preparation requires about twice as long an exposure as wet collodion.

Developer.

Take a saturated solution of gallic acid and a few drops of a solution of nitrate of silver (fifty grains to the ounce of water). By varying the quantity of nitrate of silver any kind of tone can be got. A small quantity yields brown tones; a larger quantity black tones.

Fixing.

Wash thoroughly, and then fix in the ordinary solution of hyposulphite of soda; finally wash and dry.

The collodion film in this process facilitates the flowing of the albumen, which besides dries much quicker. Its keeping properties are very good.

HINTS ON SUCCESS AND FAILURE IN PRINTING.

[MESSRS. LAMPREY, TIBBITTS, AND Co., of Paternoster Row, have recently issued a very useful pamphlet, entitled "Toning Formulae, and Instructions for Printing," &c. It is intended for especial use with their albumenized papers, but it contains a mass of valuable and trustworthy practical information on the general subject of printing and toning. We advise our readers to procure it. The following pithy summary is extracted from it.]

As all photographers know, one operator will succeed and another will fail, even with precisely the same materials and nominally the same formulæ. We cannot by the use of any

materials or formulæ *guarantee* success in all hands; but we can supply such materials and such recipes as *ought to succeed*, and we can point out some of the causes of failure.

WEAK PRINTS.—The primary cause of weak, feeble, poor prints, is the use of a thin or fogged negative. Without a good negative, it is impossible to obtain good prints. If the negative be good and the prints poor, it may arise from several causes—the nitrate bath being too weak or too acid; the paper not floated long enough or too long; not being sufficiently printed; being over-toned, left too long in the fixing bath, or in the first washing water after fixing. A marbled or mottled effect is often due to the use of a weak silver bath.

MEALINESS.—This is a term used to designate a fact with which many photographers are familiar. It consists in a granular mottled effect of grey and red spots on the surface of the print. It most commonly occurs where the negative used is thin, and does not permit very deep printing. It sometimes proceeds from the use of a very acid printing bath; sometimes from using a toning bath when too recently mixed, or containing free acid, or from using a lime bath containing too much chloride of lime. The best remedy, when the tendency exists, is slow toning; an old acetate bath has the least tendency to produce it. In some cases submitting the print, prior to toning, to a bath of acetate of soda, without gold, is found to check the tendency to mealiness.

RAPID DISCOLOURING OF THE EXCITED PAPER.—The use of an alkali nitrate bath, or of a bath containing acetic acid, will cause this, or keeping the bath in a warm and damp place; and the fumes of ammonia, hydrogen, gas, &c. After exciting, the paper should be dried in a warm place, and then kept in a cool dry one, and of course quite dark. Changing the prints in the frames, or examining the progress of the print and toning or fixing in daylight, are frequent causes of dull, degraded whites. The paper being kept too long between exciting and finishing the picture, produces a similar effect.

IRREGULAR BRONZED MARKS.—Impurities on the surface of the sensitizing solution.

YELLOW MOTTLED STAINS IN THE PRINT arise from using an old or weak hypo bath, or allowing the prints to stick together whilst fixing.

BROWN AND METALLIC STAINS often arise from handling the prints before fixing with fingers which have touched hyposulphite of soda.

HARD PRINTS WANTING IN HALF TONE, when not the fault of the negative, may arise from using the silver bath too strong.

SPECKS AND MARKS OF VARIOUS KINDS often arise from dust or marks at the back of the negative, or on the glass of the printing frame.

RED CIRCULAR SPOTS.—Air bubbles under the print whilst toning.

PRINTS REFUSING TO TONE.—This will arise sometimes from allowing too long a time to elapse between exciting the paper and toning; or from the gold bath becoming inert or exhausted, in which case, add a little more fresh gold solution; or from putting the fingers into the gold solution after they have touched hyposulphite of soda, and so decomposing the bath. The use of old collodion baths for exciting hinders toning.

PRINT RED AFTER FIXING.—Under-toning.

PRINT HAS A COLD, ASHY, BLUE COLOUR, WHEN DRY.—Over-toning.

THE ALBUMEN LEAVING THE PAPER generally arises from the silver bath being too weak.

A BLOTTED AND BAD TINTED COLOUR sometimes arises from the washing before toning not having been carried far enough, and from the print having been washed in water containing lime.

DIRTY WHITES are often to be traced to the use of a fixing bath that has been employed before, or to a discoloured nitrate bath.

THE WHITES OF THE PRINT ARE NOT SUFFICIENTLY PURE, BUT GREY AND DIRTY.—This may arise from exposure to light, use of ammonio-nitrate of silver, in damp and warm weather; contact with ammonio-nitrate paper; use of damp flannel on the back of the paper, or of flannel impregnated by frequent use with ammonio-nitrate of silver; too much exposure to the heat of the sun.

The exciting, printing, toning, and fixing should, where it is possible, be done within one day; and the utmost care and cleanliness used throughout. The fixing bath should not be used twice, and should contain one ounce of hyposulphite of soda in five ounces of water.

Many defects and failures, not otherwise explicable, arise from the use of impure chemicals. It is, therefore, economical, both as regards time and money, to procure the very best that can be had, quite irrespective of the cost.

AN ARTIST IN TROUBLE.—HELP WANTED.— PINHOLES AND VARNISH.*

MR. EDITOR—You know it was the character of the old Jewish nation to be always leaning on their own right arm until they were well whipped by some nation whose right arm was stronger than theirs; well, so it is with me; I like, when I get into trouble, to work my way out of it, and heretofore I have always succeeded, thanks to those "useless" publications, the photographic journals; but this time I have broken down flat, flatter, flattest.

About a week ago I ran short of ether, so I tried some from a drug store, and it failed, then I borrowed some, but from some cause the cotton would not settle in it although in former cases it settled all right, and the same ether gave my neighbour good, clear collodion. I take pains to procure good chemicals (iodide and bromide of ammonium and cotton), he uses whatever his stock dealer happens to send him—of course this collodion would not work, so as I had just received a fresh supply of ether, I made a fresh lot of collodion that looked beautiful, and here began my real trouble. I coated a plate, and it produced a very fine negative, and I thought my trouble all over; but alas! for human foresight; my second and third came out all right, the fourth showed pinholes which increased in quantity and quality until I had to stop altogether. Feigning business, I left my room and staid out until it was too late to work, and so saved my reputation for that day. At night I adopted my "never-failing" remedy of boiling my bath. As I expected, the first plate next morning showed all right again, but before half a dozen plates had been dipped, the pinholes were as numerous as ever. Thinking something was wrong with the bath dish (one of Stock's glass baths with rubber bottom and sides) I filtered a part into a porcelain bath and tried again: this helped, but did not cure, so I set the larger portion of the solution in the sun, where it stood from nine o'clock A.M. until dusk, when it was perfectly limpid, with a white deposit completely covering the bottom of the bottle; this I filtered clear, and as before obtained A 1 negatives at first, but the same trouble reappeared. I then reduced my solution with pure rain water until it was quite milky, and added silver to restore its strength to fifty grains per ounce. This proved an exact repetition of my former attempts, so that night I evaporated my solution to dryness, and then fused the silver. This just gave the same results, three or four fine negatives, and then gradually they went down to totally worthless. I now tried to see whether lengthening the time in the solution would change the effect, and *thought* the pinholes a trifle large. I then dipped my plate and took it out as soon as it ceased to show oily lines; what result say you? Not a pinhole but a splendid cedar swamp instead!

Here sickness gave me what a musical friend called a "three days rest." On resuming I thought I had fooled away time enough with the old solution, so I made a new one with Powers and Weightman's silver, and also a new batch of collodion made as follows:—

Ether	8 ounces
Alcohol	8 "
Iodide of ammonium	80 grains
Bromide "	32 "
Soluble cotton	130 "

This looked fine, and to my great pleasure my first negative was a splendid one, yet my old fate followed, and at night I could not make a negative of any value. I must own beaten, but unlike the champions of the "peculiar institution, I can't "skeddadle." Old dame Nature did not give me the

* *The American Journal of Photography.*

ability to flee either fast or far, so I assume the old salt's motto, "Never say die while there's a shot in the locker."

I hope long before the next Journal comes, to be all right again, but thinking that some of your friends might have travelled over similar ground, I would like to know how they got "out of the woods."

One of your Minor Correspondents is in trouble with his varnish, I cannot tell him the cause of the trouble, strictly speaking, but I can tell him both how to remedy it and how to avoid it. To remedy it, simply varnish the plate a second time, and (of course) dry it by a gentle heat. To prevent it, leave the varnish bottle open for a short time in a warm room, and there will be no trouble with opaque spots. I have taken negatives that were laid aside as worthless, and restored them so quickly that the owners would not believe I told the truth in regard to the means, until they had proved it.

I am sorry to see so little from the pens of our own artists, although I have no right to find fault, having left you entirely for a long while, but if I don't get a "situation" in Uncle Sam's shooting party now organizing for a grand hunt "among the pines," or elsewhere, as may be decided upon, I will try to send you an opinion; meanwhile I am, yours truly,

A. S.

Erie Pa., August 16th.

[Our friend A. S. in his troubles seems to have proceeded *secundem artem*. He ought to have been relieved of his difficulties; we never knew of similar cases where such remedies as he used did not prove effectual.

The common and well approved theory of pinholes, when they do not come from an imperfectly settled collodion, is that they originate from impurities of the bath. For a decisive test in a doubtful case, the collodion should be tried in another bath which has been proved to be in order. We have observed, however, where the pinholes are undoubtedly produced by deposition of iodo-nitrate or other foreign matters of the bath, that some unknown condition of the collodion has still much to do with the manner and amount of the deposition.

A good remedy, as we proved some years since, for pinholes, or a sandy appearance of the film, is to wash the plate after it comes out of the bath—this washing takes away the bath impurities; then before exposure, pour over the film a pure bath solution. This plan invariably secures a good clean negative. For regular working it would be advisable to have a water bath standing beside the silver bath, in which the sensitized plate should be rinsed, before washing under the tap (this may be omitted), for the purpose of saving the silver. The final silvering should be effected by pouring rather than dipping, as the latter takes twice as much silver as is really required. This plan would be economical of silver, while the photographic results would without doubt be nearly uniform notwithstanding the varying condition of the bath and the collodion.

Apròpos of saving silver in ordinary working, we suggest that just before developing, the plate be dipped in a water bath to remove the superfluous silver from the back; probably sufficient would remain in the film for development, and if not, let it be added as needed.

At a late meeting of the Photographical Society, President Draper recommended the plan of washing thoroughly before exposure, and of restoring the silver at the time of development.

These matters are full of interest and we hope to learn more from A. S. and others—En.]

Correspondence.

FOREIGN SCIENCE.

[FROM OUR SPECIAL CORRESPONDENT.]

Paris, September 30th, 1863.

An amateur photographer has communicated to the *Moniteur de la Photographie* an ingenious idea of the application of

the stereoscope to microscopic photography, which he has patented. He states that the employment of stereoscopic photographs occupying a very small surface permits of our giving to the stereoscope dimensions as limited as may be desired, and, consequently, render this instrument capable of assuming any form. Besides, the facility of combining a given number of pictures on a plate of small dimensions permits of a considerable reduction in the price of each proof.

The process of obtaining these stereoscopic proofs is very simple. A plate containing two stereoscopic pictures is placed in a frame, which maintains them in a fixed position. The back of this frame is covered with ground glass, which is lighted by the direct rays of the sun, by reflected light, or other means. I place in front of this frame a small camera with two objectives, and I take by the usual process, on albumen or collodion, two positives on glass.

The two reduced pictures thus obtained are exactly similar to those obtained by ordinary printing methods, and although they are ten, twenty, or even a hundred times smaller than the negative, the stereoscopic effect they produce is still the same if we view them with two lenses of sufficient magnifying power.

To judge of the stereoscopic effect, one single condition is indispensable. It is, that the two stereoscopic proofs be seen simultaneously by both eyes of the experimentalist. Hence it is evident that every imaginable form may be given to the stereoscope, for this condition is always easy to fulfil. I will describe a few of these forms.

1st. The simplest of all will be to place two stereoscopic proofs in two little lorgnettes, which may be connected by a chain. By taking one of these lorgnettes in each hand, and placing them both before the eyes at the same time, the picture will be seen in all its relief.

2nd. We can take any number of stereoscopic proofs on the same glass plate. Upon one part of this plate is placed the pictures A, B, C, D, E, etc., and on another the pictures AA, BB, CC, etc., which, to be viewed simultaneously, must have an interval between them corresponding to the distance between the eyes. To see all the images in succession, we make the glass plate containing them slide in front of two little microscopes suitably placed.

3rd. We can take a number of proofs arranged in a circle on two small discs of glass, mounted so as to partake of a rotary movement in the same plane. Two little fixed microscopes serve to view the stereoscopic proofs simultaneously.

The elements of this invention are not new. Microscopic photography is known to everybody, and so is stereoscopic photography. Nevertheless, the combination of these two things produces an artistic result which no one has hitherto foreseen, and for which I consider I am justly entitled to a patent.

It is not, I repeat, this form or that of stereoscope that I claim as my invention, but only the employment in the stereoscope of photographic proofs of very small dimensions which can be seen only by the aid of lenses more or less powerful.

Under the title of *photogenie*, Messrs. Susse frères have attempted to popularize photography after a fashion. Alongside of the outfit for *potichomanie* and *decalcomanie*, we now find an elegant ornamental box containing some small bottles, a miniature bath, a light frame, and a stock of engravings. With these appliances and a little practice, young amateurs can obtain photographic pictures with as much ease as they can sketch a flower or a figure. Everything is prepared for use, and there is no danger of the rosy fingers becoming stained. The albumenized paper is covered by means of a sponge dipped in the sensitizing solution, then placed in the frame under the engraving to be copied. After an exposure, which varies from fifteen minutes in the sun to an hour in the shade, the paper is immersed in water, then placed on a sheet of cardboard and covered with a solution of tannic acid; the proof is then washed and immersed in a solution

of sulphate of iron, washed again, dried, and varnished with gum-water. The resulting picture is permanent, for it is composed of tannate of iron. This process is quite as simple as *decalcomanie*, and will, doubtless, meet with an equal share of success.

Paper of very fine quality has for some time past been manufactured in Austria from the leaves of the *maize*, or Indian corn. Herr Auer, the director of the Imperial Printing Office, at Vienna, has issued a large album containing specimens of maize-paper of all kinds, thicknesses, and dimensions.

This plant, grown so extensively in the South of Europe, in the United States, and other parts of the world, furnishes one of the most important cereals that contribute to the nourishment of mankind. The leaves, for which no use had hitherto been found, except as fuel, contain three valuable elements: a textile material, a nutritive pulp, and a glutinous substance. The first is spun and woven; the second, which keeps fresh in the open air for several months, furnishes a nourishing and wholesome flour: all the filamentous and glutinous residues of the pulp resulting from the extraction and fabrication of the textile material are converted into paper. As may be perceived, nothing is lost. As for the paper, it has all the qualities of that made of rags: whiteness, suppleness, toughness, and transparency if required; it appears even more homogeneous. It will also be much cheaper, as soon as its manufacture is established on an extensive scale. Paper of this manufacture will, doubtless, prove interesting to photographers, as it will be free from many of the defects inherent to paper prepared from rags, as well as from its accidental impurities, so fruitful a source of spots.

THE TRIPLE V. THE GLOBE LENS.—ENGLISH PORTRAITURE, ETC.

MY DEAR SIR,—Mr. Waldack, on his return to this country, delivered to me your present of several beautiful photographs. The work of Dallmeyer's triplet, as compared with Harrison's globe lens, shows conclusively the superiority of the former, as compared with the latter, in the fact that the square picture cut from it includes more picture than the square picture cut from Harrison's, both being the same subject, and, I presume, both taken from the same spot.* I have a "six-inch globe lens that, so far from covering "a circle of light twelve inches in diameter," barely covers the corners of a $6\frac{1}{2} \times 8\frac{1}{2}$ plate. This lens is called "Six-inch focus," when in reality it is over seven inches. The focus measures six inches from the centre of the back lens, which projects a half-inch from the brass work. Measuring from the central stop to the ground glass it is more than seven inches. This practice of measuring focus from the back lens, without stating the length of the brass tube, is erroneous, and calculated to mislead the photographer.

I am using a lens made by Henry Fitz, of New York, which has a focus three-quarters of an inch longer than the globe, makes an image but very little larger, works much more rapidly, *completely* covers sharply an 8×10 plate, and costs much less than a six-inch globe. I think this lens resembles Dallmeyer's, as it seems to work out the corners of the picture in the same manner. I believe this Fitz lens can be used for in-door portraits as it works perfectly with a large opening, although I have not as yet fully tested it on this point. I will send you by next steamer a pair of prints made with the two lenses, so you can compare them. I still think there is a lack of uniformity in the manufacture of the globe lens, so if any of my Philadelphia friends "burst with indignation" because their "globes" work better than mine, then they or I will be open to conviction.

In conclusion, allow me to express my thanks for the photographs you sent me. I am at a loss which to admire most, but will submit them all at the next meeting of the

Photographical Society, in October, for comment. I think that the portrait of V. Blanchard cannot be excelled. I am told this was taken under a skylight, and the surroundings made up. If this be so, then we surrender the palm for making up in galleries, old marbles, shrubbery, &c., &c.† Then the portrait of Mr. Hardwich (where are his robes?) is universally admired. It is to be hung up in my house as a gem of art. The paper it is printed on is elegant in surface and finish. Whose is it? † Yours, respectfully,

F. F. THOMPSON.

New York, September 4th, 1863.

P.S. Since writing the above, yours of the 20th ult. has been received. I see you noticed the same peculiarity of working the corners with Dallmeyer's lens as I did. I apologise for the lack of regularity in my letters, but can promise better hereafter, as I have just now completed my new den, which has taken my time all summer, and can begin to do something again at pictures. I will secure to you the early reports of our Photographical Society when they again meet, and write anything of importance that may occur. I go into the country in a few days, and will write a line or two from our backwoods. Until then, good-bye.—Yours, F. F. T.

FORMIC ACID IN THE DEVELOPER.

SIR,—It is with considerable diffidence I again take up my pen to approach the editorial table, after the merciless way in which Lieut.-Col. Stuart Wortley has thought proper to cut up my unfortunate letter, "Formic Acid an Accelerator;" still, I do not think it would be doing justice to myself did I not say a few words in reply.

In the first place, Lieut.-Col. Stuart Wortley appears to have taken a wrong view of the whole affair. I was perfectly aware that Mr. Malone had stated "the avoidance of bromine salts in the collodion is absolutely essential to success." His opinion, I know, is endorsed by many other photographers, still I did not know of any law to prevent photographers trying for themselves whether pyrogallic and formic acid developer and bromo-iodized collodion were so inimical to success. Lieut.-Col. Stuart Wortley should bear in mind that I was not trying for instantaneous effects, but simply whether the pyrogallic and formic acid developer would give as good results with a fair exposure as the iron developer.

Again, I did *not* profess to make experiments on M. Claudet's ideas; I merely stated that I used a *developer* of pyrogallic and formic acids, *as recommended* by M. Claudet.

I did *not* "produce a better negative with the ordinary iron developer than with a developer containing pyrogallic and formic acids." The iron negative was flat compared with the other one, whose only fault was, the shadows were a very little too deep; the detail was equally good in both.

Since my former letter to you I have used the pyrogallic and formic acid developer in many instances with my bromo-iodized collodion, and have every reason to be pleased with the excellent results produced. I enclose you two cards from negatives developed by both methods; that is, one by pyro-formic acid, and the other by iron. They were taken in a moderately good light with a Jamin card lens, five inch focus, one inch stop; exposure for each negative, five seconds. It remains for you to say which is best.

It can but be a matter of indifference to me, so long as I can work successfully in the way laid down in my letter, who approves of it, or who does not. I only stated facts, and confess I was myself astonished, after being led to suppose that no one could succeed with bromo-iodized collodion and pyro-formic acid developer to get such good results.

As to the inutility of my experiments, many amateurs have an unconquerable aversion to iron development, conse-

* A portrait of Mr. Blanchard, by himself, in the costume of a Roman peasant, taken in the glass room he described in our pages. It is one of a series sent out by Mr. Blanchard, as illustrating the qualities of his collodion for iron development.

† A whole plate vignette portrait, by Mr. T. R. Williams, a charmingly perfect photograph and a fine likeness.

quently are precluded from using a bromo-iodizing collodion, but by a slight modification in the pyrogallie acid developer, as recommended in my letter, the beautiful results obtained by using a collodion containing bromide and iron development, can be got by them, with exactly the same manipulation as for simply iodized collodion and pyro development.

I cannot do better, in conclusion, than quote your excellent remarks, contained in page 444 of the News for the week ending Sept. 11th: "Whilst we never receive things as truths except on satisfactory evidence, we do not reject well authenticated statements as falsehoods simply because they appear improbable. Many things appear improbable simply because they belong to a range of facts which have not come within common experience."—I have the honour to be, Sir, your most obedient servant.

W. A. Moss, Sergt. A. H. C.

[Free discussion generally tends to the more perfect elucidation of any subject. We think it is probable, however, that Col. Stuart Wortley understood our correspondent to be experimenting with M. Claudet's process, and either mistaking or mis-stating the formula. The presence of a bromide has generally been regarded as injurious with pyrogallie acid development, and M. Claudet excludes it from his formula as we have repeatedly stated. That it is inimical, however, to perfect results, we are not so well assured as Mr. Malone appears to be. If Sergeant Moss is to blame for trying it with a pyrogallie solution and formic acid, we are not less so, for in two articles last June we stated that we obtained with bromo-iodized collodion and pyrogallie and formic acid development, results equal in rapidity and delicacy, but with a little more brilliancy, than with the same collodion and ordinary iron development. Sergeant Moss's pictures bear the same relations as our own. Some time ago Major Gordon presented some very fine and soft instantaneous pictures to the French Society, the peculiarity of which was that they were produced with a highly bromized collodion and pyrogallie acid development.—Ed.]

THE INVENTION OF THE TRIPLE LENS.

DEAR SIR,—Will you grant me space for a few lines in the PHOTOGRAPHIC NEWS, to answer some misstatements by Mr. Sutton in the *Photographic Journal* just issued.

A month must elapse before the error could be corrected in that journal, and for this reason I ask the use of your columns.

Mr. Sutton finds fault with the phraseology of the jurors in their Report of the Exhibition where they refer to the triple lens invented by me, and claims the origin of the Triple Lens for himself. Permit me to state that the Triple Lens invented by me and which has proved a success, has nothing in common with the "Symmetrical Triplet" invented by Mr. Sutton, and which proved a failure.

Domestic sorrows disincite me for entering further into the discussion at present, on a future occasion I shall have more to say on the subject; in the mean time I will conclude by confuting Mr. Sutton by his own words. On a recent occasion when I had to point out that my lens had been copied by another maker, Mr. Sutton remarked that "Mr. Dallmeyer ought to be pleased" to find that another maker had "verified by a series of experiments his own original results." (See *Photographic Notes*, May 1st, 1863). Yours truly,
J. H. DALLMEYER.

BAD GLASS PLATES.

DEAR SIR,—I send by this post a patent glass plate for your inspection. It is a fair sample of a lot of glasses I've just had down, every glass is covered with a peculiar mark which seems to me burnt in the glass. I've tried every scheme I know, but I can't get rid of them. When I unpacked them, there was a piece of paper between each to keep them from being scratched, the mark of which you will see is left, and defies all my efforts to get rid of it. Now,

can you, or any of your readers, inform me the cause of it, and the remedy? I shall be greatly obliged if you can. I've soaked them in strong nitric acid, cleaned them with a solution of tripoli, alcohol, salt and water, and put by for use. Before using, I've cleaned the plate with alcohol, yet in spite of all these precautions, I can't get rid of the marks. I had them of a first-rate London House and paid a long price for them, so they ought to be up to the mark. Hoping you will be kind enough to see to this and help me out of my trouble, I remain, yours respectfully,
R. T. BACK.

P. S.—If you can't find out the remedy, and tell me in the notice to correspondents, I should, if you have space enough, like you to publish my letter in the NEWS, as some of my brothers in distress might lend me a helping hand.

[The marking is similar to what we have met before. It has a smoky mottled effect, and defies all attempts to remove it. It does not always show when the picture is taken, but it does sometimes. We never met with it on patent plate, nor do we believe this to be patent plate. It looks like foreign polished sheet, of which one side only is polished. Perhaps some of our correspondents can supply more information.—Ed.]

EDEN'S MICROSCOPIC CAMERA.

SIR,—The camera you noticed and engraved in a recent number for taking micro-photographs, was made originally, four or five years ago, by a Mr. Potter (then resident in York, and now in my employ) for Mr. Willis, then of York, and now of Scarborough. Mr. Eden, about four years since, got Mr. Potter to make one for me, which I have still in my possession—Mr. Eden being then in my employ. The mirror has certainly been added since, as also the dark frame at the wide end, but these are the only improvements introduced by Mr. Eden, in every other respect it is like mine. I have written this to you because I think Mr. Potter should have the credit of its construction and arrangement, and as for the "patent," I should have no hesitation in infringing it if any person favoured me with an order, inasmuch as the real inventor would have to make them.—I remain, sir, yours truly,
J. CASCATELLI.

Manchester, September 8th, 1863.

[We must leave Mr. Eden to explain this charge of copying.—Ed.]

Photographic Notes and Queries.

IMAGE ON THE RETINA OF A DEAD EYE.

MR. WARNER presents his compliments to "Enquirer." He will, when he has leisure at his command, be happy to give his ideas upon the above subject. Also upon "non-actinic weather," upon which some curious facts are in his possession from all parts of the world. At present, his time is too much taken up with enlarging, printing, &c., &c., to enable him to give that attention to the subject which it justly demands.

Ross, September 18th, 1863.

GUTTA-PERCHA NEGATIVE TRANSFERS.

THE late ever to be commended Mr. Archer proposed this plan for the preservation of negatives, and it secures great economy of space to travellers. After the negative was completed he poured over it a solution of gutta-percha, and allowed it to dry. The plate was then placed in water and a gutta-percha negative or a negative on gutta-percha instead of glass was obtained from off the glass. The glass plate might then be cleaned and another negative taken on the same plate; the gutta-percha negative being easily preserved on being placed in the leaves of a book. These gutta-percha negatives bear very free handling; they can be printed from without any more, perhaps less, difficulty than any other kind of negative, and I have seen some still as perfect as when they were first made some years since. The invention was one of the greatest value to travellers, inasmuch as it saved the necessity of their carrying with them the contents of a glass shop. What have been the obstacles to the general adoption of this invention?

C. C.

[Except the trouble of removing the films, and a little tendency in the film and gutta percha to shrivel and get into creases, we have not heard of any disadvantage attending the process in question.—Ed.]

NITRATE OF SODA IN ALBUMENIZED PAPER.

SIR,—Perhaps the following suggestion may be of use to albumenizers. I have recently had some paper prepared for experiment as follows:—To each ounce of chlorodized albumen I added sixty grains of nitrate of soda. I find much more brilliant prints are the result. I have tried this paper on a weak bath, and find I get more brilliant results than with the same paper usually prepared without the nitrate, and sensitized on a 70-grain bath. A larger proportion of nitrate of soda may be more advantageous.—I remain, Sir, yours respectfully,

PUBLICOLO.

P.S.—I intend to have all my paper so prepared for the future.

Talk in the Studio.

MEDALS OF THE CORNWALL POLYTECHNIC SOCIETY.—We are glad to be able to record that the adjudicators of prizes at this society have awarded the first silver medal for the best photograph in the exhibition to Mr. H. P. Robison, of Leamington for his charming picture of "Stoucleigh Deer Park," and to Col. Stuart Wortley the medal for the best collection of photographs consisting of some magnificent instantaneous pictures.

ART PHOTOGRAPHS.—Mr. Blanchard has just issued a few very charming whole plate art studies, consisting of Italian peasants and other subjects. The especial object is to illustrate the quality of negative produced by his carte de visite collodion with simple iron development without intensifying. Photographically they are perfect, round, delicate, full of gradation and yet admirably vigorous. They also exhibit fine artistic feeling. The pose, expression arrangement of accessories, &c., all are good.

OBITUARY.—It is with deep regret that we announce the sudden death of Mr. Bland, of the firm of Bland and Co. (formerly Bland and Long). He had been indisposed for a few days, but not seriously, and on Wednesday, the 23rd, was suddenly taken worse and died. He had been for many years connected with the business of a philosophical instrument maker and dealer in photographic apparatus, in which position he was highly respected, whilst his personal qualities, his constant courtesy, his kindly and urbane manners, won the esteem and regard of all who came in contact with him.

To Correspondents.

W. G.—The only method of producing enamel or burnt-in photographs which has been patented in this country is that of M. Joubert, which consists in coating the plate with a mixture of a chromic salt, albumen, and honey, and after exposure under a transparent positive applying vitreous colours in powder, and burning in the usual muffle furnace. We believe you are quite at liberty to practice the other methods which you indicate.

D. JONSON.—We have not had much experience as to the keeping qualities of simply washed and dried plates. Tannin plates carefully prepared will, we believe, keep some months; and collodio-albumen plates, especially if they receive a thorough final washing, and then a coat of a solution of gallic acid, will also keep many months. The real action of a preservative coating of some organic substance in dry plates is not well ascertained. Some maintain that its action is chemical; others, headed by Dr. Hill Norris, contend that it is merely mechanical, and simply serves to keep open the pores of the film. We do not know of any method of intensifying dry plates better than the use of pyro and silver, preceded, if necessary, with a wash of a solution of iodine.

ST. DENNIS.—The album and other views issued by Mr. Wilson are published by Marion and Co., of Soho Square.

NEMO.—We do not see that any advantage will be gained in using a nitrate bath of 100 grains to the ounce for dry plates. Where bromized collodion only is used, and in large proportion a strong bath is desirable, but not nearly so strong as you mention. You cannot with advantage use a larger portion of iodine than the film will hold with convenience when formed into iodide of silver. If you use much more than is commonly used you will be troubled with all the results which follow over-iodizing.

P. J.—The kind of fogging which you describe, and which may be rubbed off the image, leaving it very weak, is probably caused by a want of relation between your nitrate bath and developer. The latter is probably new, somewhat strong, and without a large proportion of acid. Your nitrate bath is probably weak, and the image is chiefly formed on the surface of the film. Your best remedy will be to increase the proportion of acid in your developer. The yellow glass in your dark-room becoming too pale

would cause fogging, but the fogging from diffused light does not rub off the image easily.

C. C.—The quantity of water should have been stated in ounces.

Z. φ.—We cannot state certainly the cause of the spots. They have very much the appearance of having been caused by splashes of some liquid at the back of the paper after it was sensitized.

J. R. N.—The last edition of Mr. Hardwich's "Manual of Photographic Chemistry" is the sixth. We have not seen any announcement of a new edition. It is not probable that any other edition will pass through Mr. Hardwich's hands. 2. Mr. Sutton's work on carbon printing gives all details of Mr. Pouncy's process, and of some others. There is no work describing all the methods of carbon printing which have been invented. 3. The remedy for the curling of card pictures in rolling is to use a roller of larger diameter. Or, if they are rolled face down on a steel plate, they will be less likely to curl. 4. *Humphrey's Journal* is an American Photographic Journal, published in New York. 5. If you suspect that your bath contains too much acid, neutralise it by adding a solution of bicarbonate of soda until a slight permanent precipitate is formed, and then try it. Sometimes it will work well without any addition of acid; if it does not you can add acid very cautiously until it works.

X. Y. Z.—There are various samples of collodion in the market which adhere well. We have found that which you are mixing—Blanchard's—to adhere very firmly to the glass.

D. W., Aberdeen.—The black colour which opticians produce on the polished part of their brass work is produced by what is termed in the trade "chemical bronze." We believe this is simply a preparation of chloride of platinum, but is generally bought by the optician ready for use, of the chemist. The brass work is first thoroughly cleansed, and then the solution is applied by means of a camel's-hair pencil. The recipe in "Hardwich's Manual," to which you refer, is for producing a dead black, and is wrong for that. The brass work should not be heated, as directed, or the contrary result to that indicated will follow. A lacquer, or spirit varnish, dries dead only when applied cold, and bright when applied with heat. We have not observed the cause of spots to which you refer. Your aim at perfect excellence is wise and right.

A. GRENET.—The back lenses of an ordinary portrait combination are arranged as follows:—The double convex lens is first placed in its cell, with the least convex side downwards; the ring is next placed upon it to preserve the proper separation; the other lens is then placed upon that concave side downwards, and the brass collar screwed in to retain them in position. They then present the effect of one very thick double convex lens.

E. E. D.—The best moist preservative which we know for keeping the plate fit for use for a few hours is that described in our pages by Mr. Blanchard, about twelve months ago, and also in our last PHOTOGRAPHIC NEWS ALMANAC.

J. H. C., 42.—There is no distinct work on producing photographic transparencies. Major Russell's work has a short chapter on producing them on tannin plates, and other works have chapters on the subject. A variety of copious articles on the subject have appeared in our pages. M. Bisson has not written on the subject we believe. We are uncertain as to when the work you inquire about will be ready; it is in preparation we believe.

CORNISH COURIER.—The use of a larger proportion of bromide in the collodion is one of the best sources of gradation in glass positives. And with a freely bromized collodion the bath may be freely acidified with nitric acid. With these, and a developer containing about 15 grains of protosulphate of iron, 15 minims of glacial acetic, and 2 minims of nitric acid, we do not see how you can fail, with proper lighting and exposure, to get good and well modelled glass positives. We do not believe that the use of methylated alcohol in the collodion will present any difficulty. We have produced many hundreds of glass positives as fine as ever we saw, with such collodion. We have experimented largely with methylated spirit, and have no reason to believe in the alleged evils.

AN OLD SUBSCRIBER wishes Mr. Bartholomew to state "why" he uses the sediment of chalk in his toning bath, seeing that the chloride of lime neutralizes any free acid, and the acetate of soda would bring about the necessary decomposition, and he quotes Mr. Sutton's statement that all additions beyond chloride of lime are useless or injurious. Pending Mr. Bartholomew's answer, we may remark that we first published a formula for a toning bath with chloride of gold and chloride of lime only, that of Mr. Lacy. In many hands it gives exceedingly fine results. But it has certain disadvantages. If used within a week after it is mixed it generally gives meanness. Again this difficulty arises, whilst chloride of lime is sufficiently alkaline to neutralize any free acid, it sometimes happens with some samples of chloride of gold, that if sufficient chloride of lime be used to neutralize it, too much free chlorine is added at the same time. To produce the best results the proportion of chloride of lime must be kept within proper limits, and hence the utility of a salt like carbonate of lime to complete the neutralizing process where it is necessary, and which will be simply innocuous when it is not needed to neutralize any free acid.

W.—We think it is probable that the collodion being new and horny, or repellent, probably causes the mottling. The use of a more permeable collodion, or of a weaker tannin solution, or washing after applying the tannin solution, may prevent the defect. We hope, in our next, to give Major Russell's opinion on the subject.

Several Correspondents in our next.

Photographs Registered during the Past Week.

MESSRS. E. G. WOODWARD AND CO., 10, Eastgate Street, Gloucester,

Two Photographs of Thalberg.

MR. W. H. BARTON, 26, Triangle, Clifton, Bristol,

Four Photographs of the Very Rev. Canon Ward.

MR. FREDERICK SNARY, 26, Castle Street, Bristol,

Two Photographs—Views of Church of England "Training College," Fish Ponds, near Bristol.

MR. JOHN STEWART, 129, Buchanan Street, Glasgow,

Four Photographs of the Rev. Wm. Arnott.

MR. RICHARD DAVIES, 26, Ridley Place, Newcastle-upon-Tyne,

A Drawing in Water Colours—"The Jubilee," a scene in Sandgate, Newcastle, upon the occasion of his Majesty, George III., entering the 50th year of his reign.

A Photograph from the above.

THE PHOTOGRAPHIC NEWS.

Vol. VII. No. 265.—October 2, 1863.

CONTENTS.

	PAGE
Alkaline Development—Mackerel Marks on Tannin Plates	469
New Dry Process—Catechu as a Preservative. By W. S. Craig	470
The Manufacture of Photographic Collodion. By W. L. Noverre	471
Auto-Cupric Toning Bath. By C. Ommegeanck.....	472
On the Measurement of the Chemical Action, &c. By R. W. Bunsen, For. M.R.S., and H. E. Roscoe, B.A.	473
Printing, Toning, and Fixing Direct Positives on Albumenized Paper.....	474
Proceedings of Societies—North London Photographic Association.....	475

	PAGE
Correspondence—Foreign Science—Formic Acid in the Developer	
Imperfect Photographic Glass—Prizes at the Royal Cornwall Polytechnic Society—Want of Intensity in Tannin Plates—Eden's Microscopic Camera—A Photographer's Rambles, &c.	476
Photographic Notes and Queries—The Fuming Process—Retaining the Specimens of Operators—Transfer of Films—Chalk in the Toning Bath—Gutta-percha Negative Transfers	479
Talk in the Studio	479
To Correspondents	480
Photographs Registered during the past Week	480

ALKALINE DEVELOPMENT—MACKEREL MARKS ON TANNIN PLATES.

The principle of alkaline development for dry plates appears to be gaining general recognition. Nevertheless, with it, as with several other not perfectly understood processes in photography, there is much discrepancy in the experience of different operators. The results, as described by some, are equal to those produced by the wet process and with an equally short exposure; whilst with others spots, fog, and rotten films, are the invariable followers of an alkali in the developer. Others again, not failing like the last, nor gaining results equal in rapidity to wet collodion, like the first, find that a decided diminution in exposure, and a facility in successful development, are obtained by the judicious use of ammonia or soda in the developing solution. Amongst our recent correspondents we have illustrations of the two last classes, and a recent article in the *Photographic Notes* speaks of results similar to those referred to in the first class. Our own experience in this direction has not been very extended, but it has been tolerably successful. We have succeeded in obtaining clean, rapid, and satisfactory results, but not equal to those from wet collodion and iron development. Before speaking of our own experiments we will make a brief extract from one of the communications we have received on the subject. After referring to his failure to obtain good results with any moderate exposure, on tannin plates prepared with simply iodized collodion, our correspondent, signing "Delta," says:—

It has occurred to me, that in the various references to the origination of alkaline development, one name has been very singularly omitted, and as photographers are much indebted to the owner of that name for many valuable suggestions in your pages, it appears to me that this omission ought to be rectified. I refer to Mr. Bartholomew.

In the *PHOTOGRAPHIC NEWS*, for January 3rd, 1862, I find in an article, by Mr. Bartholomew, the following suggestive remarks, in describing three new dry processes:—"The third formula involves the recognition in dry plate photography of a principle which has hitherto not been noticed. It occurred to me that if, in the wet collodion process, we require free nitrate of silver, acid reaction, and no organic matter; so, probably, in the dry collodion process, we require no free nitrate of silver, alkaline reaction, and organic matter." He then proceeds to describe a process in which gelatine is used as a preservative, with a solution of carbonate of soda either added to the solution or applied afterwards; and he adds, that plates so prepared are equal in sensitiveness to those prepared by the wet process.

Now, sir, it appears to me that here is the germ of the modern improvement in development very distinctly set forth, and that to Mr. Bartholomew is due the credit of first proposing the heterodox notion that alkaline conditions might be advantageous in dry plate photography. It is the more important that this recognition be made, as I see, in the *PHOTOGRAPHIC NOTES*, that Mr. Sutton, who has become a convert to this mode of development, as he did to the use of bromides, has recently propounded, as a new preservative, a mixture of albumen, honey, and carbonate of soda, a mixture which,

although not the same, is uncommonly like Mr. Bartholomew's, and which, at the time, I believe, Mr. Sutton pool-pooled.

I see also that Mr. Sutton, after describing the alkaline development, of which we have heard so much in your own and other journals, and in Major Russell's last edition, concludes, comically enough, by claiming the process in an off-hand, incidental manner, by conjuring his readers to "give our process a fair trial!"

I tried the alkaline process, described by Mr. Bartholomew, with some success, but I did not find the plates keep, and there was a tendency to stains; but with alkaline development and tannin plates I have had a fair share of success, with very few drawbacks. I have never obtained anything like the rapidity of the wet process, but have been able to get good results, with half, and in some instances, with a third of the exposure necessary in the ordinary mode of development. The method with which I have had the greatest success is that which you described as practised by Mr. England a few months ago.* The chief difficulties I have found consist in a tendency to fog, if too much alkali be used, or if the plate be under-exposed, and the alkaline pyro-solution be applied a long time to bring out detail.

Regarding the origin of the alkaline principle it is very difficult to decide. The suggestion of Mr. Bartholomew undoubtedly seems to enunciate the very principles which are now gaining recognition, and was the first broad statement of the idea that alkaline conditions, generally regarded as so inimical to success with collodion plates, might possibly be in dry-plate photography absolutely necessary to the best and most rapid results. But these conditions had nevertheless been used at an earlier date. In July, 1861, we published an article on certain experiments we had made with a process suggested by the Rev. J. Lawson Sisson, in which the preservative was a mixture of borax and gum. Now borax, although by constitution an acid salt, has, nevertheless, an alkaline reaction, and behaves in many respects like an alkali. In our hands the plates so prepared gave very rapid results, but were occasionally apt to fog, behaving in many respects like the gelatine alkaline dry plates. Mr. Bartholomew is an able and ingenious experimentalist, to whom photographers are largely indebted, and, had his suggestion been followed out earlier, would probably have led earlier to results similar to those now obtained. But, as we have before observed, we think that to both Mr. Leahy and Major Russell, as well as Mr. Bartholomew, is due the credit of independent discovery in the matter of alkaline development.

In our own recent experiments we have used some plates which had been forwarded to us as defective, being covered with singular markings. They were coated with a commercial bromo-iodized collodion prepared for the wet process; excited in a thirty-grain bath; well washed, and coated with a fifteen-grain solution of tannin. They had been prepared about three months when we used them. The light was, unfortunately, of the most unsuitable quality; a dull, yellow, misty light, in which it would have been impossible to get

* See *PHOTOGRAPHIC NEWS*, p. 253 of the present volume, May 29th.

brilliant results by any method. With a single lens of twelve inches focus, and a half-inch stop, we gave one plate an exposure of five minutes, with a subject to which we should have given about two minutes and a half with a wet plate and iron development, and to another eight minutes. To one or two other plates we gave an exposure of forty seconds with a Dallmeyer's No. 1 B lens, and a half-inch stop; the light requiring a twenty-second's exposure with wet plates. We also exposed some plates under a negative for about five seconds to diffused light, and for about thirty seconds close to the light of a fish-tail gas-burner. As the plates had not received any preliminary coating we gave each an edging of varnish to prevent the films slipping.

We then proceeded to develop: having moistened a film with common river water, we applied a solution containing four grains of bicarbonate of soda in an ounce of water. In about a minute, if the plate had been fully exposed, a dim phantom of the image was seen; if not very fully exposed no image is seen at this stage. A three-grain solution of pyrogallic acid is now applied, and the image is quickly seen looking vigorous and red by reflected light, but without any density whatever when examined by transmitted light. When all the detail is fully out, the plate is thoroughly washed, and a two-grain solution of pyrogallic acid with a few drops of citro-nitrate of silver applied until the proper intensity is obtained, which, if the proper conditions exist, is secured without difficulty. Mr. Sutton recommends after washing away the alkaline pyrogallic solution, that an ordinary pyrogallic solution, containing acetic acid, but no silver, be applied first in order to prevent any fog when the solution containing silver reaches the film. If the plate have been fully exposed, and all the detail is well out, this may be done with safety; but if there be any lack of detail, it is better not to apply the acid solution without silver, as it prevents the further development of any latent detail which may exist. Instead of applying the solution of bicarbonate of soda first, the plain pyrogallic acid solution may be applied, which will educe a phantom image, and on the addition of the soda solution, will rapidly acquire detail and apparent force; and may be intensified as before.

Those plates which have been exposed the right time, progress under the treatment described in all respects satisfactorily, a clean, soft and forcible image being obtained, of a reddish black tone, the image quite in the film, without any appearance of superficial deposit. Indeed, the film looks bright and polished, and might be smartly rubbed without disturbing it. All the transparencies presented this appearance and some of the negatives. The two plates exposed in the worse light, and with a landscape lens, were not satisfactory. That which has the shortest exposure looked fogged from pushing the development, and that which had a longer exposure, was flat and unsatisfactory from a universal deposit in the film having almost the appearance of over-exposure. We have before noticed that with some dry plates, no amount of exposure in a bad foggy light is of any avail. Those plates exposed with the portrait lens, were a trifle under exposed, but developed satisfactorily, and with out fog or stains.

Where a plate after fixing lacked vigour, we found no difficulty in intensifying by first applying a solution of iodine and iodide of potassium in water, followed by iron, citric acid, and silver.

We used carbonate of soda in preference to liquid ammonia, which we had used before, because we found that it gave us less trouble with rotten or tender films. Carbonate of ammonia, which Major Russell, who has so thoroughly worked the process, recommends, we have not yet tried carefully.

The stains and markings to which we referred at the commencement of this article are very curious. We have heard of them two or three times, and had seen some slight resemblance to them, but not in such a degree. They appeared in some plates like mackerel markings; in others they assumed an arborescent appearance, like the branches

of a tree, the markings being much thicker and denser looking than the rest of the plate, which appeared opalescent, whilst they seemed creamy. The collodion used was very thick, and gave a horny film, and it appeared possible that to its impermeable condition the markings were due. Strange to say, however, with the treatment we have described, there was no appearance of the markings whatever in the finished negatives. Last week we received a communication from a very skilful photographer, who has been very successful with tannin plates, complaining of something similar, but which appears during development. All is described as working well for the wet process, but in the tannin plates mottled skies appear, as if the tannin solution had not taken kindly to the excited film, and had only permeated it imperfectly, notwithstanding the utmost care in manipulation and formula. We submitted the case to Major Russell, in the hope that his experience might suggest the cause and remedy. He has not, however, met with the difficulty; but suggests the use of a larger proportion of alcohol in the tannin solution, and allowing it to remain longer on the plate. If the tannin solution had been washed off, he adds, then doing that imperfectly might cause the mottling, thorough washing being necessary to secure an evenly sensitive surface. The nearest approach Major Russell has seen to such markings is a defect produced by washing the plate with hard water before the free nitrate was fully removed with distilled water, and in that case the markings had a dull appearance by reflected light.

In another page we give a letter from Major Russell, on a new form of difficulty and its remedy.

NEW DRY PROCESS—CATECHU AS A PRESERVATIVE.

BY W. S. CRAIG.

HAVING made some trials in quest of a preservative in the dry collodion process, of easy preparation, good keeping qualities, and rapidity of effect, I was induced to think this was most probably to be found in some vegetable product containing the requisite proportions of tannin, extractive matter, and mucilage. I made a trial of a decoction of lentiscus leaves, the result of which was encouraging, but there appearing to be a deficiency of tannin, I made a trial of a decoction of sumach, which was a decided improvement; and, perhaps, more from curiosity than necessity, I made a third trial with a decoction of catechu, the result of which left nothing further to desire, and I have now been using it with invariable good success for the last two years.

In landscapes my exposure is thirty seconds with a single lens, 13½-inch focus, and half inch diaphragm; and with a good light, I can take instantaneous views with the stereoscopic camera.

Heat is favourable to the process, and seems to accelerate its operation. I have, by way of experiment, left the landscape camera for four minutes under the influence of a blazing sun, when the thermometer marked 84 in the shade; of course the resulting negative was over-done, but still usable; and I may notice, in conclusion, that I have kept some of the preservative for upwards of a year, and that it is still as good as ever.

With this brief preface, I will now proceed to describe my process.

Preservative.

Boiling, distilled or rain water 20 fluid ounces

Pulverised catechu ... 400 grains.

Mix and stir well, when cold, filter through cotton wool, measure the resulting decoction, and add 10 per cent. of alcohol, strength 39 Beaume.

Collodion.

The collodion I use, and which I make myself, is by Robiquet's formula, only I have considerably increased the quantity of the bromide of cadmium in it. My receipt is as follows:—

Gun cotton	159 $\frac{3}{10}$ grains
Gun flax	39 $\frac{3}{105}$ "
Amber varnish	637 $\frac{6}{5}$ "
Alcoholic extract of gum-lac	159 $\frac{1}{15}$ "
Iodide of cadmium	198 $\frac{2}{10}$ "
Bromide of "	144 "
Ether... ..	63 cubic inches
Alcohol	15 $\frac{8}{10}$ "

Coating the Plate.

Coat the plate and excite as usual. I give three minutes in the nitrate bath.

On taking the plate from the bath, immerse it in a tray of water, rock it gently about half a minute, repeat the process in a second tray, after which pour water over it, so as to free it completely from free nitrate, and prevent stains. Now pour on the preservative, flow it round and round for about half a minute, pour it off again, wash the plate freely, and set it aside to dry.

Developer.

Pyrogallie acid	1 $\frac{1}{2}$ grains
Citric acid	3 " or 60 acetic acid.

Pour this once or twice on and off the plate, then add about one-fourth of a 10-grain nitrate solution, pour this over the plate; the image will now appear, and rapidly acquire the requisite intensity.

The catechu I make use of appears to be the Malabar, the only kind I can get here.

Cagliari, September 24th.

THE MANUFACTURE OF PHOTOGRAPHIC COLLODION.*

BY W. L. NOVERRE.

THE IODIDES AND BROMIDES.

The iodides and bromides most suitable for bromo-iodized collodion are those of cadmium, ammonium, and lithium.

The iodide of cadmium is an exceedingly stable salt, and collodion iodized with it will remain colourless for a very long time, the reason of its not being more generally used is the property it possesses of making collodion thick, so that it has to be kept several months in the iodized state before it becomes sufficiently fluid for use; it is, however, very valuable, when mixed with the less stable iodides; it tends to make the collodion set more quickly on the plate than an alkaline iodide. Bromide of cadmium is stable like the iodide, and does not thicken collodion in the same manner.

Iodide of ammonium is an unstable salt; it rapidly liberates iodine from collodion and renders it limpid; it is usually met with in crystals of a yellow colour, due to free iodine. This may be removed by washing the crystals in ether and drying them on blotting paper. This iodide is useful for mixing with iodide of cadmium, as it counteracts the property, which the cadmium salt possesses, of thickening collodion. The bromide of ammonium is not unstable, like the iodide, and is preferred by some to the iodide of cadmium.

Iodide of lithium is an opaque, colourless salt, exceedingly deliquescent, and must therefore be kept in a closely stoppered bottle. It possesses the advantages of the cadmium and ammonium salts, without their drawbacks. Thus it has little effect in causing the liberation of iodine from collodion, and, like ammonium, renders it limpid and structureless. Collodion iodized with iodide of lithium turns a pale lemon colour after a few days, and remains without further change for many months, provided the salt is pure, and that the plain collodion is not acid. Iodide of lithium retards the setting power of collodion, a desirable quality in hot weather. This property can be modified at will by using it in conjunction with iodide of cadmium. Bromide of lithium does not appear to possess any advantage over the bromide of cadmium, and is much more expensive.

THE BROMO-IODIZED COLLODION.

The proportions of alcohol and ether that will be found most convenient for general purposes are two parts of the former to one part of the latter; this is a larger proportion of alcohol than is usually recommended, but the formula will be found to possess many advantages. As has already been shown, ether is a very unstable substance, therefore the less of it there is in the collodion the longer may it be expected to keep without decomposing. A collodion containing a large proportion of alcohol is very valuable for coating large plates, and for general use in hot weather, as it enables the operator to coat the plate leisurely, and the fumes of the ether, which are very irritating to the eyes, are not felt during the operation, which is a great boon to the photographer who has to work in a tent or other confined space. It has been alleged by some that an excess of alcohol in collodion is injurious to sensitiveness—this is not found to be the case when using pyroxyline of the kind that has been described, and when a bromo-iodizer is employed. With regard to the kind of iodide used affecting the sensitiveness of the collodion, much diversity of opinion prevails; there does not appear, however, to be any perceptible difference, provided each is used when it has reached its most sensitive condition. With regard to the effect of various iodides on the keeping properties and upon the mechanical state of the collodion, sufficient has already been said.

The normal collodion is prepared as follows:—

Pyroxyline	18 grs.
Ether (sp. gr. .725)	1 oz.
Alcohol (sp. gr. .805)	1 "
Alcohol (sp. gr. .820)	1 "
Iodide of lithium	7 $\frac{1}{2}$ grs.
Iodide of cadmium	6 "
Bromide of cadmium	1 $\frac{1}{2}$ "

Place the pyroxyline in a bottle, add the alcohol (sp. gr. .805), and shake up till the cotton is wetted, then add the ether, and agitate till solution of the cotton is complete; next dissolve the iodides and bromide in the alcohol (sp. gr. .820), and add to the collodion, shake the whole together, and put it by in a dark place to settle down. The cotton, if properly prepared, will dissolve entirely in the mixture of ether and alcohol, and when the collodion is perfectly bright and clear, it may be drawn off from the sediment at the bottom of the bottle with a glass syphon as already described. It will be fit for use after it has been mixed for a week or ten days, and will gradually improve for a month or more. Collodion should be kept in the dark, or it will become ozonized, liberating iodine, which tinges it a yellow colour. This will often disappear again on placing it in the dark. When the clear collodion has been drawn off, a plate should be coated and sensitized. If it is found to give a pale opalescent film, and to repel the developer, the alcohol was too strong, and two or three drops of water must be added to each ounce of collodion, in order that it may give a more creamy film; if too much water is added, the film will be reticulated. It must be remembered that bromides have a tendency to produce an opalescent film.

Collodion used soon after iodizing will often give a picture covered with pinholes, and having a deposit on the transparent parts of the negative. Pinholes may be often prevented by filtering the iodizing solution before adding it to the plain collodion, and the deposit on the shadows can be obviated by adding a little tincture of iodine till the collodion is of a pale sherry colour.

Collodion prepared by the above formula will keep for many months in the iodized state without deterioration.

If it is intended for use soon after mixing, for coating large plates, it will perhaps be necessary to reduce the quantity of pyroxyline to five grains per ounce of solvents, or iodide of lithium may be substituted for the quantity of iodide of cadmium given in the formula, which will in-

crease the limpidity of the collodion. If the collodion is only intended to keep for a few months, iodide of ammonium may be substituted for the iodide of lithium in the formula, as the latter is a very expensive salt. If ether of a higher specific gravity than that advised in the formula is used, a little more of the strong alcohol must be substituted for that of sp. gr. .820.

The proportion of bromide given in the formula is sufficient to make the collodion work cleanly without reducing its intensity, but it will be found advisable to increase the proportion of bromide when the light is strong, or in photographing objects presenting powerful contrasts of light and shade, and for instantaneous work. For certain subjects, equal quantities of iodide and bromide may be used, and as much as 4 grains bromide to 2 of iodide have been employed with advantage for particular purposes. Collodion should not contain more than 6 grains of iodide and bromide together, so that, when it is desired to use a large quantity of bromide, a certain proportion of plain collodion must be added to combine with the excess of iodide. A table is given below, by which a collodion containing any proportion of iodide and bromide may be obtained ready for immediate use. The solutions required are the normal bromo-iodized collodion, plain collodion, and the same with a bromide dissolved in it. These are numbered respectively 1, 2, and 3, for convenience in reading the table. The quantity selected is about eight ounces, being considered a convenient quantity.

THE SOLUTIONS.

1. *Normal Bromo-Iodized Collodion*, containing $4\frac{1}{2}$ grains iodide and $\frac{1}{2}$ grain bromide per ounce.

2. *Plain Collodion*.—Pyroxyline 15 grains, ether (sp. gr. .725) 1 ounce, alcohol (sp. gr. .805) 1 ounce, alcohol (sp. gr. .820) 1 ounce.

3. *Bromo-Iodizing Solution*.—Dissolve 24 grains bromide of cadmium or ammonium in 1 ounce of No. 2 solution.

Number of grains of iodide and bromide per ounce the collodion is required to contain.		Quantity of No. 1 solution to be taken.	Quantity of No. 2 solution to be taken.	Quantity of No. 3 solution to be taken.	Quantity obtained of the collodion desired.
Iodide.	Bromide.				
$4\frac{1}{2}$	$\frac{1}{2}$	8 ounces.	—	—	8 ounces.
$4\frac{1}{2}$	1	8 "	—	4 scruples.	8 ounces 4 scruples.
$4\frac{1}{2}$	$1\frac{1}{2}$	8 "	—	8 "	8 ounces 8 scruples.
4	2	7 "	$\frac{1}{2}$ ounce.	$\frac{1}{2}$ ounce.	8 ounces.
3	3	6 "	2 "	1 "	9 ounces.
	4	$3\frac{1}{2}$ "	$3\frac{1}{2}$ "	$1\frac{1}{2}$ "	8 ounces.

It is hoped that the details which have been given will not appear tedious. The manufacture of collodion of uniform character is a nice operation, and one requiring care and great method in every part of the process. If the directions given in this paper are carefully followed out, a failure can scarcely occur.

AURO-CUPRIC TONING BATH.

BY C. OMMEGANCK.

Most of the toning baths at present employed present certain difficulties of management, because they are not fit for use as soon as prepared. It is necessary for the chloride of gold they contain to be more or less deprived of its chlorine by the contact of some alkaline salt, without which, the proofs submitted to its colouring action are weakened. We can easily accelerate the decomposition by slightly warming the

bath solution for immediate use, but how frequently it happens that it becomes heated too much or too little, and moreover, a warmed bath never tones so well, nor lasts so long as one in which the exchange of the chlorine has been made slowly, at ordinary temperature. How many times have we found ourselves embarrassed with a bath, either too new, or which has lost its strength by the effect of the heat of the atmosphere, and at a loss what to do when we have had proofs to tone, whether the bath should be prepared the day before or some days in advance?

By warming the bath, we therefore uselessly complicate operations already sufficiently difficult; a toning bath is really only practically useful when it can be prepared at the moment of using.

This object may be obtained by various formulæ, but the following appears to us the most advantageous of all, on account of its simplicity, of the great rapidity of its colouring power, and the facility with which we can obtain every desirable tint.

Water	35 $\frac{1}{2}$ ounces
Chloride of gold	7 $\frac{1}{2}$ grains
Deuto-chloride of copper	1 $\frac{1}{2}$ "
Carbonate of soda, sufficient to produce an alkaline reaction.				

By varying the quantities of chloride of gold and chloride of copper, we obtain a variety of tints from black to blue grey, with all the intermediate tones.

The bath is prepared in the following manner:—Dissolve in aqua regia 90 grains of metallic gold, and add from 50 to 75 grains of common salt, then evaporate to dryness by a gentle heat, and dissolve in $3\frac{1}{2}$ ounces of water. This gives a solution of about 10 per cent., 6 parts of metallic gold giving about 10 parts of chloro-hydrate of chloride of gold.

In the next place, dissolve 75 grains of metallic copper in aqua regia, and evaporate the solution to dryness by a gentle heat. 5 parts of metallic copper give about 10 parts of deuto-chloride of copper; dissolved in $35\frac{1}{2}$ ounces of water, it gives a cupric solution of 1 per cent.

If the salts are bought ready made, dissolve 15 grains of chloride of gold in 3 fluid drachms of water and 15 grains of chloride of copper in 30 drachms of water.

Pour into a suitable dish a volume of water corresponding to the bath required; for each 100 parts of water add $\frac{1}{2}$ part of the gold solution and 2 parts of the cupric solution. Put in a piece of litmus paper, which will become red in a few minutes; then add, drop by drop, a solution of pure carbonate of soda, and stir. When neutralized, the litmus paper will recover its blue colour. The bath is now ready for use, and will keep good several hours. When its energy begins to slacken, the addition of a few drops of the solution of chloride of gold will revive it, but it is necessary to be assured that the reddened litmus paper continues to turn blue after this addition of chloride of gold.

Before immersing the proofs, we commence by soaking them in a small quantity of water, in which they may remain some time without inconvenience; then they are placed in a larger quantity of water for a few seconds, and afterwards passed rapidly through a third quantity of water. Lastly, they are immersed in the toning bath, and continually moved about, especially during the first moments of their immersion, and frequently examined. If any proofs are noticed with red spots arising from contact with greasy fingers, remove them from the bath, place them in water, and dry them with filtering paper. Then pass a pencil dipped in a solution of carbonate of soda (saturated) over the spots; leave them for a minute, immerse them in water, return them to the toning bath, and the spots will have disappeared. The number of proofs that may be saved by this simple operation, which would necessarily have been lost, will certainly form a rich collection.

As the proofs are removed from the toning bath they are collected in a water bath. When all are toned they are

fixed in a fresh solution of hyposulphite of soda—strength 15 to 20 per cent. An immersion of 5 minutes is generally sufficient. At the end of this time the proofs are fixed, and have resumed the hue they had before being placed in the hypo. The transparency of the paper in the whites also indicates to a certainty the entire solution of the salts of silver incrustated in the pulp of the paper. Prints over-printed, and which are generally regarded as lost, are treated like the others, but they are left in the hypo as short a time as possible, until their transparency is complete. They are then washed in two waters, and immersed in a saturated solution of hypo. They rapidly lose their colour, and are not less permanent and beautiful than the others. It is also a means of obtaining detail from negatives too thick in the lights. We have only to print to a bronze colour, except in the whites, and then fix as described above.—*Bulletin Belge de la Photographie.*

ON THE MEASUREMENT OF THE CHEMICAL ACTION OF DIRECT AND DIFFUSE SUNLIGHT.

BY R. W. BUNSEN, FOR. M.R.S., AND H. E. ROSCOE, B.A.*

IN one of the four communications which the authors have already had the honour of presenting to the Royal Society on the subject of the measurement of the chemical action of light, the attempt was made to determine experimentally the laws regulating the distribution of the chemical action of the sunlight and diffuse daylight on the surface of the earth when the sky is perfectly unclouded and the atmosphere clear. The methods of measurement there employed do not, unfortunately, apply to the much more usually occurring case of cloudy skies and hazy atmosphere. The aim of the present communication is to describe an entirely different mode of measuring the chemical action effected at any point on the earth's surface by the total sunlight and diffuse daylight, under the most widely varying conditions of situation, climate, and state of the atmosphere.

In spite of the various futile attempts which have been made to register and measure the chemical action of light by means of photographic tints, it still appeared possible in this way to attain the desired end. No instruments founded on such a mode of measurement can yield reliable results, unless we know the conditions under which photographic surfaces of a constant degree of sensitiveness can be obtained, and unless the relations be determined which exist between the degree of tint produced, and the time and intensity of the light acting to effect such a tint.

The first point which the authors examine, is whether the photographic tints produced vary in shade in the direct ratio of the intensities of the acting light. Several experiments proved that no direct ratio between the degree of blackening and the intensities of the light exists. Hence it is necessary to relinquish the idea of employing any mode of measurement founded on the comparison of photographic tints of different shades. The next point examined is whether equal shades of blackness always correspond to equal products of the intensities of the acting light into the times of insolation. For the purpose of testing the truth of this proposition, an instrument is employed, by which photographic sensitized paper can be exposed for times, which can be exactly measured to within small fractions of a second. This instrument consists essentially of a pendulum vibrating about $\frac{2}{3}$ seconds, by whose oscillation a sheet of darkened mica is withdrawn from, and brought back over, a horizontal strip of paper prepared with chloride of silver, and fixed in a constant position relative to the pendulum and sheet of mica. The time during which each point in the length of the strip is exposed is different, and the time of insolation for each point can be calculated when the length and position of the strip, and the duration and amplitude of the pendulum's vibration is given. A table exhibits for each

millimetre in length of the strip, as measured by a scale attached, the time of exposure in seconds, which the corresponding point of the strip undergoes in one vibration of the pendulum. These numbers require to be multiplied by n , if the paper has been insolated for n vibrations.

The paper insolated whilst the pendulum is oscillating, exhibits throughout its length a regularly diminishing shade from dark to white; and the time of insolation of any point is found by reference to the table. If we wish to determine which of these shades corresponds to another tint produced by a separate insolation, we cannot make the comparison by daylight or ordinary lamplight, as these lights produce considerable changes of tint in the sensitive paper. The two shades may, however, be perfectly and safely compared by the light of a bright soda-flame; this light possesses the great advantage of being chemically inactive, and likewise of rendering imperceptible those slight differences of colour which make the comparison of two shades by the ordinary light so difficult.

In order to compare any other photographic tint with the point of equal shade on a strip, the latter, together with its millimetre scale, is attached to a board, in a darkened room. The board slides in a groove, so that it can be moved horizontally; and in front of the paper strip a small block holds in a fixed position a small piece of the tinted paper which it is desired to compare. On throwing the light of a bright soda-flame upon both surfaces, it is easy, by moving the board from side to side, to find the exact point at which the shade of the strip is identical with that of the other tinted paper. It is then only necessary to consult the table in order to find the time in seconds during which the paper must have been exposed in order that it should attain the tint in question. A series of lights of known intensities was obtained, by allowing the sun to shine through holes of known size. The images thus formed fell on to a piece of prepared paper; and the tints produced were compared with a strip darkened in the pendulum apparatus, and thus the time of exposure necessary to effect the shade determined. Experiments made with intensities varying from 1 to 50, show that within these limits equal shades of blackness correspond to equal products of the intensities of the acting light into the times of exposure; so that the light 1 acting for the time 50, produced the same degree of blackening as the light 50 acting for the time 1.

A method for measuring the chemical action of light by simple observations is then founded upon this proposition. Thus, if we assume as the unit of photochemical action that intensity of light which produces in the unit of time a given degree of shade, we have only to determine, on a strip of paper tinted in the pendulum apparatus, the point where the shade of the strip coincides with the given tint; the reciprocals of the times which correspond to these points of equal shade give the intensities of the light expressed in terms of the above unit.

This method of measurement is available only—

1. If the phenomena of photochemical induction do not interfere with the blackening of the paper.
2. If a photographic surface of a constant degree of sensitiveness can be prepared.
3. If an unchangeable tint can be obtained which can be exactly compared with the photographic paper.

The result of a series of experiments made by varying the number of the vibrations and calculating the intensity from each observation, showed that photochemical induction does not exert any prejudicial effect upon the measurements.

The question into which the authors enter at greatest length as being the most important for determining the exactitude of the measurements, relates to the mode of preparing a standard paper possessing a constant degree of sensitiveness. The relative degree of sensitiveness is determined by exposing the papers to one and the same light for the same length of time, and then comparing their tints with the shades of a strip prepared in the pendulum—

* *Philosophical Magazine.*

apparatus, fixed in a solution of hyposulphite of soda, and furnished with an arbitrary scale. The influence of the strength of the nitrate of silver solution upon the sensitiveness is first examined; a series of experiments shows that with the same homogeneously salted paper, the sensitiveness of the film does not alter when the strength of the silver solution varies from 8 to 10 or 12 parts of nitrate of silver to 100 of water. Further examination showed that the time during which the paper lies upon the surface of the silver bath may vary from 15 seconds to 8 minutes, without any difference in the sensitiveness of the paper being noticed; and no difference is found by the employment of silver solutions which had been long in use and those freshly prepared. The papers thus silvered may be preserved for from 12 to 15 hours in the dark without undergoing any change in their sensitiveness.

If the paper be allowed to float on the surface of the solution of chloride of sodium, as on that of the silver bath, the sheet after silvering exhibits, on drying, a very unequal degree of sensitiveness in its various parts. If, on the contrary, the sheet be well soaked in the salt-bath no such irregularity appears, and the sheet is of an equal degree of sensitiveness throughout its whole surface. This fact is determined by several extended series of experiments. The effect of change of concentration of the salt-bath upon the sensitiveness of the film is very great; and, as far as the observations extend, no limit exists beyond which an increase or a diminution of the percentage of salt in solution ceases to affect the sensitiveness of the film. Hence, in order to obtain constant results, it is necessary to employ a solution of chloride of sodium of constant strength. By using solutions of the same strength, papers of a constant degree of sensitiveness are obtained.

The influence of the thickness of the paper employed is next examined. Experiment shows that differences in the thickness of white paper, such as is usually employed for photographic purposes, is without influence upon the sensitiveness of the film of chloride of silver.

The changes in atmospheric temperature, from 3° C. to 50° C., and in atmospheric moisture, are likewise found not to influence the sensitiveness of the prepared paper.

From the experimental results detailed in the communication, it appears that, by adhering to a certain mode of preparation, a standard paper can be obtained, which at all times possesses a degree of sensitiveness sufficiently constant for the purposes of exact measurement. In the following extract from a larger table, the readings are given which were made from papers prepared in three different salt solutions of the strengths mentioned, and silvered in a solution containing 12 of nitrate of silver to 100 of water. Equality in the numbers in each of the columns III. and IV. denotes equality in the readings and in the tint, and therefore equality in the sensitiveness of the prepared surfaces. Three sheets of paper were dipped into each solution. These numbers likewise show the great degree of accuracy with which tints can thus be compared.

I. Paper.	II. Na Cl to 100 parts of water.	III. Intensity No. 1.	IV. Intensity No. 2.
Upper part of sheet No. 2	3.026	87.0	75.4
Middle part of sheet No. 3	2.950	86.3	74.4
Middle part of sheet No. 2	3.028	86.0	74.9
Lower part of sheet No. 2	3.000	85.9	74.4

The next subject considered is the preparation of an unvarying tint which can be easily obtained and used as the standard of comparison. This is effected by grinding together 1,000 parts of pure oxide of zinc with 1 part of pure lamp-black. A series of experiments showed that a colour can thus be prepared which possesses a constant and unalterable shade; and this can be used as a measure of the standard tint.

Having proved that a standard photographic paper of constant sensitiveness, and a standard tint of unvarying shade can be prepared, it is only necessary to apply the proposition that equal products of the intensities of the light into the times of insolation effect equal shades of blackness, in order to find a method of comparative measurement of the chemical action of the total daylight. As the *unit* of measurement, the authors propose to adopt that intensity of the light which in one second produces the standard tint of blackness upon the standard paper.

When the standard paper is insolated in the pendulum-apparatus, a strip is obtained which is tinted with every gradation of shade from dark to white. If the point on this strip is determined which coincides in shade with a paper covered with the standard tint, we have only to look into the Table to obtain the time of insolation (*t*), in seconds, which is necessary to produce the shade corresponding to the reading on the millimetre scale. If this time of insolation were found to be one second, the intensity of the light then acting would be $I=1$; for any other time the intensity of the chemical rays would be $\frac{1}{t}$.

As an example of such measurement, the authors append three series of observations, giving the total amount of chemically active rays falling on a horizontal surface at Manchester in summer and winter, made at intervals of 10 minutes throughout three separate days. These observations are likewise graphically represented as curves, which show maxima and minima exactly corresponding to the appearance and disappearance of the sun; and from them some idea may be formed of the vast differences which occur in the intensity of the chemical rays falling on the earth's surface during the longest and shortest days.

In conclusion, the authors state that it is possible, by using the pendulum-apparatus, to construct a portable instrument by means of which a large number of observations can be made upon a few square inches of paper. They reserve the description of their instrument for a future occasion.

PRINTING, TONING, AND FIXING DIRECT POSITIVES ON ALBUMENIZED PAPER.*

AMMONIO-NITRATE of silver is more sensitive to light than nitrate of silver, as is also the chloride of silver produced by double decomposition with ammonio-nitrate of silver and any of the alkaline chlorides; it produces more vigorous pictures, and sensitizes the paper more quickly than the simple nitrate of this metal.

2. These are very important qualities in photography; it has, however, its disadvantages or difficulties, which are the following:—Free ammonia easily dissolves the albumen from the surface of the paper, whereby the solution becomes discoloured, forming albumenate of silver; this deteriorates the effectiveness of the solution for future operations; the paper is reduced again to plain salted paper, and the picture is mealy, imperfect in the middle tones, and possesses but very little vigour.

3. The question, therefore, arises: How can the ammonio-nitrate process be modified so as to obviate these disadvantages? We have experimented with various reagents, such as ether, hot water, acids, &c., and have selected, as successful in a high degree, the following method, by which the albumen surface is preserved entire, the tone is a rich purple black, all meanness or snowiness avoided, and uniformity of action maintained.

Silver Bath.

4. Dissolve one ounce of nitrate of silver in six ounces of rain water; of this solution take two ounces, and add ammonia until the precipitate is redissolved; afterwards mix these with the remaining four ounces. Now add four drachms of alcohol and allow the oxide of silver to settle. If any particles still swim on the solution, remove them by drawing a small sheet of paper two or three times over the surface. It is not necessary—it is not even injurious—to filter the solution; for the sediment is oxide of silver, which is afterwards dissolved by the addition of ammonia.

* From Humphrey's Journal.

The paper, already cut and prepared according to art, is made to float on the silver for about ten seconds; all bubbles and particles that may adhere are carefully removed from its surface, and afterwards it is dried in the usual manner. Every time this bath of silver is again used fresh crystals of the nitrate are added together with a few drops of ammonia and about one drachm of alcohol.

Toning.

5. The prints are first well washed in several waters; the operation may be performed in ten minutes or a quarter of an hour; if the time is much longer, the tone is impaired. They are then passed through hot water previously to their immersion in the toning solution. This solution is formed as follows:—From the stock bottle containing one part citrate of soda and six parts water, take two ounces; to this add one pint of warm water, one ounce of rain water, holding in solution one grain of chloride of gold, or more, according to the number of prints to be toned, and two drachms of alcohol. The toning soon commences, and is soon finished if the gold is of sufficient quantity. The temperature must be preserved at a blood-heat, or about 100° Fah.; if it were greater the gold would become decomposed, and the solution blackened instead of the prints; if lower, the time of operation will be prolonged, and the operation itself tedious. The alcohol in this solution prevents all action of the alkali on the albumen, whereby the vigour of the print is preserved. We do not use the same bath twice unless immediately, and then of course with the addition of more gold. After the toning is finished, any gold that may remain is reduced by sulphate of the protoxide of iron, and collected.

Fixing.

6. The fixing medium consists of the ordinary solution of hyposulphite of soda. Every time I use this bath I add fresh crystals of this salt, two drachms of alcohol and an ounce or two of warm water. The prints, previous to their immersion in this bath, are again passed through warm water. The colour of the prints is not much changed when the prints are introduced, or if slightly changed, they soon regain their original and final tone. In two or three minutes the prints will be sufficiently acted upon by the hyposulphite, and are then removed into the water bath and thoroughly washed. The material point in these preparations is the use of alcohol in each subdivision; because upon this reagent success depends. Carbonate of soda may be used instead of citrate in the toning solution; the tone, however, is a richer purple black with the latter than with the former.

I would finally remark that unless the negative be properly and successfully taken with due contrast of light and shade, and without a universal fogginess over the whole surface, deep purples or blacks can never be obtained by any process; the silver salt has to be thoroughly acted upon by light in order to receive the desired toning.

Proceedings of Societies.

NORTH LONDON PHOTOGRAPHIC ASSOCIATION.

The first meeting of the Society after the summer recess was held on the evening of Wednesday, Sept. 23rd, in Myddelton Hall, Islington; Mr. G. DAWSON, M.A., in the chair.

The minutes of a former meeting were read and confirmed, after which the following members were duly elected:—Mrs. Verchoyle, the Rev. A. B. Cotton, F. W. Hart, and A. Harman.

No paper having been provided for the evening, the proceedings were of a conversational and desultory character.

Mr. G. WHARTON SIMPSON brought under the attention of the meeting the new process introduced by M. Beyrich, of Berlin, for removing the albumen film containing the image from a print on prepared paper and transferring it to a plain or curved surface, or glass, porcelain, &c. He exhibited one or two specimens, and explained the *modus operandi*. (For details, see the PHOTOGRAPHIC NEWS, of Sept. 4th, page 421.) He also showed some prints from which the film had been removed, but which still contained very deeply printed images, although of a redder tint than the film which had been removed.

A long and desultory conversation on the process and the purposes to which it might be applied, followed. After which, the question of their probable permanency was discussed, several members suggesting that photographic experience of

albumen was not favourable to the idea of permanency where it was employed. After some conversation on the superior permanency of developed prints and negatives, especially these on waxed paper.

The CHAIRMAN expressed his conviction that this superior permanency was due to the nature of the deposit, which in developed prints consisted of metallic silver, whilst in ordinary prints it was probable that it consisted of a sub-chloride or a sub-oxide. He had some waxed paper prints which were done twelve years ago, and which were not very carefully washed, and these had not faded at all; whilst ordinary prints, taken at the same time, and more carefully treated, were all gone.

Mr. SHAVE made some confirmatory remarks, and observed that the wax probably aided in protecting them.

Mr. HART referred to the fact that wax paper negatives were developed with gallic acid, and said that he had some very early collodion positives, which were developed with pyrogallic acid, which were not in the slightest degree faded.

Mr. SIMPSON said, he believed that carefully kept collodion pictures, either positive or negative, were quite permanent. Probably, in developed pictures, there was a more perfect deposit of metallic silver; but if the mere fact of the presence of metallic silver were regarded as a guarantee of permanency, it might be argued by those who, with Mr. Spiller, denied the sub-chloride theory, that, as all prints consisted of metallic silver, all ought to be permanent.

The CHAIRMAN said there was some essential difference in the deposit. Albumen negatives, however, were also apt to fade. Some taken by Rees and Thompson's process, in 1852, had faded, whilst waxed paper negatives, taken at the same time, were quite permanent.

Mr. SIMPSON: And yet the albumen negatives were developed with gallic acid?

The CHAIRMAN: Yes.

Mr. SIMPSON said, that would suggest that it was the albumen which was the cause of the decay.

The Rev. A. COTTON asked how long albumenized paper had been used for prints, and who first introduced it.

The CHAIRMAN said it was used prior to 1853. He did not know who first used it.

Mr. W. W. KING said he believed Mr. Henry Pellock did.

Mr. SIMPSON said, that in this country it was generally claimed for Mr. POLLOCK; the French also claimed the introduction, he believed, for Legray.

After some further conversation on applying the film to vases of various shapes, varnishing, &c.,

Mr. MARTIN asked if it could be burned in, and what would be the effect of submitting the image, as shewn, transferred to enamel glass, to the fire.

Mr. SIMPSON said, as the image there consisted chiefly, if not entirely, of metallic gold, substituted for silver in the process of toning, the effect of burning would be to destroy the albumen, leaving a thin purple image of gold burnt in. But the image would probably be somewhat thin and feeble, when the organic basis was destroyed. It might possibly happen that, if a flux of powdered glass, which melted at a very low temperature, were placed over it, and then submitted to the fire, a vitreous surface might be secured at a lower temperature than would be necessary for the deflagration of the albumen.

After some further conversation,

The CHAIRMAN made some remarks on the general prosperity of the Society. He regretted the absence, through illness, of Mr. Shadbolt, and was sure that all sympathised with that gentleman. As a Society, he thought they were a model for the imitation of some others, in the harmony which at all times prevailed in their meetings. He regretted, however, the general reluctance of members to prepare papers, and was confident that every one met with unexplained and interesting phenomenon continually, which might be profitably discussed, if duly recorded. If photographers would make a practice of carefully observing abnormal results, and noting all the conditions, they would gradually make a pile of information, which would bring photography into the position of a science, as certain as logic or mathematics.

Mr. SIMPSON showed some card pictures of the new solar camera arrangements devised by Mr. Stuart, of Glasgow, dispensing with the mirror, and making the condenser and machine generally follow the sun.

The CHAIRMAN said that Mr. Stuart had unquestionably produced the finest solar camera pictures that he had seen.

Mr. SIMPSON also showed a number of very fine card pic-

tures, by Mr. Parkinson, of Dieppo, and Mr. Hughes, of Rydo, to illustrate the peculiar quality of tone obtained by the use of lime in the toning bath.

The prints having been examined and much admired,

Mr. HISLOP asked what strength of nitrate bath was used in producing them? The subject of weak baths had recently been brought under discussion by Mr. Taylor, who intimated that good results might be obtained with a 20-grain solution. He had himself made some experiments and found that the prints produced with a 30-grain bath, and with a 100-grain bath, were equal in vigour and general character. The paper was then *Rive*, and he left it on the 30-grain bath as long as a quarter of an hour. The subject was a most important one, especially to amateurs, for where large sheets had to be excited, requiring a large quantity of solution, it became an expensive operation if a strong bath were imperative.

Mr. SIMPSON had made some experiments during the summer with weak solution, but for a different purpose. Finding that during the hot weather the excited paper very quickly became discoloured, he tried a weak solution, not much exceeding 20 grains to the ounce, with a trace of nitric acid. He found that paper excited on this solution would keep, even in hot weather without discoloration. With vigorous negatives he obtained, very good pictures with more half-tone than he could with a stronger solution; but if the negatives were weak, the prints were not so good, and there was a greater tendency to meanness. The object of using a strong bath was, however, to obtain vigour, as rapid excitement was considered to keep the image well on the surface of the paper. With ordinary albumenized paper, containing 8 or 10 grains of salt to an ounce of albumen solution, it was clear that very strong nitrate baths were not necessary to decompose all the chloride, and form chloride of silver. But whilst weak baths, requiring long floating, were apt to dissolve the albumen, and also to allow the silver solution to soak in, strong baths, rapidly rendered the albumen insoluble, and completed the formation of the sensitive salts of silver on the surface, thus securing an important condition of brilliancy. He was in the habit of using a weak bath with hard negatives, and a strong one with weak negatives.

Mr. HART thought long floating injurious, as the paper got thoroughly saturated with solution, instead of remaining on the surface.

Mr. HARMAN had had a great deal of experience in printing, and he found that a short floating on a strong solution gave the greatest brilliancy. With good negatives it was always possible to get good results. It was the weak or poor negatives which really tried a process.

Mr. SIMPSON said that landscape photographers who generally secured the most brilliant negatives had not the same troubles to contend with as the portraitist, who must operate frequently in a dull, feeble light, and must print such negatives as he could get. He believed Mr. Hislop's negatives were generally good ones and not deficient in vigour.

Mr. COTTON had found it a good plan to remove the paper from the exciting solution as soon as it ceased to curl, hang it up to dry, and then give it a second floating. Paper so treated gave great vigour, and the process involved no loss of time, as there need be very little time wasted in waiting.

Mr. HISLOP said some of the negatives he had used were portraits, and not very vigorous.

After some further conversation in which Mr. Hislop recommended to the attention of members an article by Professor Roscoe in the *Philosophical Magazine*. (See PHOTOGRAPHIC NEWS, p. 473).

The CHAIRMAN said he had not experimented largely with weak baths, but he thought when there was long floating it was probable that the nitrate combined not only with the albumen, but also with the size, and that favoured rapid decomposition and discoloration of the excited paper.

Mr. HARMAN preferred a 100-grain bath, and floating for 15 seconds.

The CHAIRMAN suggested that the subject be thoroughly discussed at the next meeting, and Mr. Harman undertook to bring a number of specimens floated various periods on different solutions for comparison.

Mr. HISLOP referred to the use of nitrate of soda which had been proposed in weak baths.

The CHAIRMAN said its action was curious. In water it would dissolve albumen, and, added to a weak solution of nitrate of silver new, it would dissolve the albumen; but when it had accumulated in an old and weak bath by the ordinary pro-

cess of exciting, the weak solution did not dissolve albumen, and it certainly, under those circumstances, added to the vigour of the print.

After some further conversation,

Mr. SIMPSON asked if any one had tried the American suggestion for using oxide of silver dissolved in nitrate of ammonia.

The CHAIRMAN said that, although claimed by the Americans as a discovery, it was not new. Mr. Archer used it in 1854 with plain paper.

Mr. SIMPSON showed some very fine specimens by Mr. Blanchard, produced to illustrate the working of his collodion with simple iron development without intensifying. These were much admired.

Mr. BOCKET, kindly brought for distribution amongst the members a number of card pictures of a pictorial "Life of Christ," consisting of a series of pictures, representing events in the Gospel narratives, skilfully arranged to form one complete tableau. This had been cleverly photographed so to form a good card picture.

The proceedings were then concluded.

Correspondence.

FOREIGN SCIENCE.

[FROM OUR SPECIAL CORRESPONDENT.]

Paris, September 30th, 1863.

Among the various applications of photography, perhaps few are of more interest or importance than that to the science of Anthropology. M. Potteau, of the Museum of Natural History, lately presented to our Photographic Society a large number of proofs, representing most of the soldiers belonging to the battalion of indigenous sharpshooters, styled *Tureos*, and to the squadron of *Spahis*, now in Paris. In placing these interesting studies before the Society, M. Potteau pointed out the most striking differences which characterise the races to which these soldiers belong.

Among other donations recently made to our Society, may be mentioned a stereoscope made by Mr. Dallmeyer, of London, presented by M. le Comte Nostitz, and a number of transparent positives to accompany the stereoscope. These pictures the donor obtained last year, during a journey he made in the government of Orenbourg, by the Wolga.

The United States Patent Office has presented a copy of its Report on the Progress of Industry, in the various States of the Union, for 1860. This work is in two octavo volumes, illustrated with 643 plates, and contains a description of all the patents granted during that year.

M. Hamy communicated the following remarks upon the means he proposes to employ, to avoid sulphuration of paper positives, taken upon salts of silver:—

It is very generally known that proofs fixed in hyposulphite of soda, are sometimes covered at the time of fixing, but more frequently after long exposure to the air, with a film of sulphur which destroys the picture. The chemical nature of this deposit, and the progress of its formation, are still but imperfectly understood; but it arises either from the decomposition of the fixing agent, or it may be attributed to a portion of the salt of silver which has not disappeared during the washings; it belongs to science to point out the means by which we may eliminate the last traces of hyposulphite of soda, or the complex hyposulphite of soda, silver and gold.

Now the only means of removing all the sulphur that may remain in the state of hyposulphite will be to convert this substance into a compound without action upon the colourless and soluble metallic film. Chlorine, it appears to me, should produce this result. No one, in fact, can be ignorant that put in contact with a hyposulphite, it causes all the sulphur to pass into sulphuric acid. Here, however, a difficulty presents itself in the inevitable formation of a little chloride of silver, if any of the hyposulphite of this metal remains in the proof. Besides, it forms some hydrochloric acid, which may have an injurious influence upon the

albumen. A simple washing in a dilute solution of ammonia will remove these two inconveniences. For the quantity of chloride of silver, which can be formed after the first fixing, is relatively minute, and, as for the hydrochloric acid, it will be completely removed in the washing, or become neutralized by the ammonia.

M. Regnault, the President, remarked that the process proposed by M. Hany, appeared to be very judicious in theory, but it was to be feared that in practice the chlorine would not confine its action to the hyposulphite in excess, but attack and chloridize the feeble portions of metallic silver, constituting the half-tones.

M. Moisson communicated to the Society the result of some experiments he had made upon the vitrification of negatives. M. Laulerie thought, that if we could preserve in the vitrified cliché, all its primitive delicacy, it would then be in a condition of permanence hitherto unknown; he therefore employed M. Moisson to make some experiments, which were successful, and M. Moisson exhibited to the members present, a negative, the yellow image on which is due to the incorporation of the silver, constituting the ordinary image, with the glass itself. A number of positives taken from this negative, show the benefit we may expect to derive from the method in the preservation of negatives. M. Moisson added that the glass most suitable for operations of this kind, is that with a potash base, called *verre à peindre* by glass-workers.

FORMIC ACID IN THE DEVELOPER.

SIR,—I certainly did understand your correspondent as experimenting with Mr. Claudet's process, and mistaking or mis-stating the formula.

He confirms my view by saying in his letter, without date, in your last issue, "I used a developer as recommended by Mr. Claudet."

A developer is only a subordinate part of a process, and in saying he used it as recommended by Mr. Claudet, I, of course, understood him to mean in the manner and under the conditions recommended by Mr. Claudet; viz., to develop an iodized collodion. It now appears that he did not use it as recommended by Mr. Claudet at all, but as recommended by yourself in the month of June. Then, why does he "merely think you will agree with him" as to a fact which you yourself informed him of three months ago? But he does not appear to read up what goes on in photography, as he says, "he had been led to suppose that no one could succeed with bromo-iodized collodion and pyro-formic acid developer." And this, in spite of your making known the exact contrary in June. It is this loose and vague way of writing, without sufficient information, that gives so much trouble to amateurs, who are led astray by false conclusions and incorrect statements.

But Sergeant Moss says, "It can but be a matter of indifference to me, so long as I can work successfully in the way laid down in my letter, who approves of it or who does not." I had fancied he wrote for his photographic brethren's information and guidance.

But it appears that the question is now narrowed to the fact whether or not Sergeant Moss can himself work successfully in the way laid down (not by him but by yourself), in June last; a matter, I think, hardly worth discussion to the public in general. But there is another point on which he might seriously mislead a young photographer. In his first letter he describes the pyro-formic negative as "fine, clear, well-defined, with deep shadows; perhaps, if anything, very slightly under-exposed;" the iron negative, "full of detail, but flat compared with the preceding one." In his second letter the pyro negative had "shadows a very little too deep," but it had as much detail as the iron negative, already described as "full of detail." If full of detail, how could it have been under-exposed? and how could the shadows be too deep? the deepest shadow in a negative full of detail being points of bare glass.

But to yourself, Mr. Editor, who know what an iron negative ought to be, is it not clear that the iron negative is the best, or at all events the most rapidly produced? Sergeant Moss, in his vague way, says nothing about the intensification of the iron negative. If not intensified, it would necessarily be weak and flat, taken in a bath such as he describes, if at all over-exposed. If it was intensified and still flat, that points more strongly still to over-exposure; if the intensification was properly conducted I cannot but think, therefore, that the pyro-formic negative was under, and the iron one over, exposed, according to Sergeant Moss's own showing, and that the iron developer thus proved itself the more rapid of the two.

You, sir, will, I think, agree with me that an iron negative very frequently does look flat till intensified, because, looking through an iron negative in its first stage, the gradations of opacity are so very delicate as to give it a flat appearance, but under the proper intensification, as the opacity of the whole increases, the *relative* opacity of the high and medium light increases in a different proportion till your finished negative is a good one in all points. This can be shown by printing from an iron negative after the iron only, then printing from a certain amount of intensification, then again after more intensification. This is a very instructive lesson to beginners as to the difficulty of judging an iron negative in its first stage.

I should have been glad to have entered more fully on this subject, but your space would not admit of it. I have said thus much, as I think Sergeant Moss is not conversant with good iron negatives, and his statement as to the goodness of the two negatives much calculated to mislead.—

Faithfully yours,

H. STUART WORTLEY, Lieut.-Col.

September 28.

IMPERFECT PHOTOGRAPHIC GLASS.

DEAR SIR,—In the PHOTOGRAPHIC NEWS of last week, some important statements were made respecting the modes of cleaning glass plates, and the character of surface often presented by such as have been repeatedly employed in the photographic processes. Your correspondent, Mr. R. T. Back, refers specially to the corrosion of new plates, and attributes the roughening of the glasses to the circumstance of their having been packed with intermediate sheets of paper. I have never myself experienced this difficulty, but have often had occasion to remark the facility with which some kinds of glass become decomposed or etched, by the action of water, and other more powerful chemical solvents.

Some years ago, I made experiments upon spun glass, which had then recently been proposed as an electric insulator for submarine cables, and was certainly not prepared to find that this material immediately furnishes alkali to pure water, and when left in contact for some time (in a platinum vessel), gives up an appreciable amount of soluble matter. The same result is observed when ordinary crown glass is pulverised and triturated with water, the alkali thus removed can be detected at once by red litmus, or turmeric paper. In the case of more powerful solvents, chemists are aware that caustic and carbonated alkalies quickly corrode glass, as do also liquid ammonia and solution of phosphate of soda: in the bottles used for the preservation of the two latter solutions, flakes of detached silica are usually seen floating. With the knowledge of these facts, I do not consider it wise to adopt the recommendation in your last from *Humphrey's Journal*, viz., to immerse the glass plates for several hours in a solution of "salt of tartar" (carbonate of potash); and I know by experience that patent plate is much injured by being left for a day or two in a solution of carbonate of soda. If alkali be required for the cleaning of glass plates, I should much prefer the use of cyanide of potassium, since this agent dissolves likewise the traces of a former picture, or any compound of silver, remaining as a contamination upon the surface of the plate. It is equally effectual in the removal

of soap and grease, and acts almost the part of an universal solvent. Nitric acid diluted with an equal bulk of water, answers well for dissolving the metallic impurities, and is not liable to corrode the glass. In all cases, it is, however, of great importance to avoid leaving the glasses for a long time in contact with any of these liquids, since the destruction of the first polish seems to prepare the way for a more energetic action upon the vitreous substratum. I am, Sir, yours very truly,

JOHN SPILLER.

Royal Arsenal, Woolwich, September 28th, 1863.

DEAR SIR,—For the benefit of Mr. Back and others, I beg to forward you the following remedy for dirty glasses. Wash them well in water, then wipe them dry; rub them with a cloth dipped in a saturated solution of chloride of lime; polish them without rinsing, then breathe on them, and many would be tempted to use them, but would repent it probably afterwards. Next pour on them a strong solution of iodine and iodide of potassium, which will be sure to develop such a beautiful crop of patches, to all appearance as greasy as if some fatty matter had only just been applied. No amount of rubbing will remove them, neither will nitric acid applied pure. The remedy is this: wipe them dry, dip a cloth in a saturated solution of cyanide of potassium, well rub them, rinse, wipe, and again apply the iodine and iodide of potassium solution, and you will find them free from all greasiness; but before you have quite done with them, try the usual test of breathing on them.

Now I am writing, I may as well tell you how I secure my pneumatic holder from occasionally sending my glasses to destruction. I boiled a lump of gutta percha in water, and when quite soft applied it to the top of the holder, bringing it below the rim, and moulding it a good thickness. I then made a hole in the centre of the gutta-percha for the brass pin, and forced the face flat on a piece of plate glass, well wetted with water; and when the gutta-percha was hard, I trimmed it into shape, held the polish face to the fire until sticky. I then applied the india-rubber and pressed it on a piece of glass, as before, and when the gutta-percha was thoroughly hardened, I put in the pin, with button at the top, and screwed all in order. Thus doctored, mine will hold good, like the old passports, for a year and a day.—Yours, truly,

A SUBSCRIBER *ab initio*.

PRIZES AT THE ROYAL CORNWALL POLYTECHNIC SOCIETY.

DEAR SIR,—Will you kindly state in your next impression that a 1st silver medal was awarded to Colonel Stuart Wortley for his beautiful collection of photographs. The paragraph in your last rather implies that it was a medal of a lower value than Mr. Robinson's, which was not the case. The judges had the highest possible opinion of the merits of Colonel Stuart Wortley's pictures, which for artistic effect were considered finer than any hitherto produced.—I am, dear sir, yours faithfully,

SYDNEY HODGES.

Secretary to the Royal Cornwall Polytechnic Society,
Falmouth, September 28, 1863.

[Our allusion to the medals was given in the exact words of a private letter, written by a gentleman connected with the society, and was not meant, we feel sure, to imply any want of merit in Colonel Stuart Wortley's pictures, which are truly described as "magnificent specimens." We have before recorded our opinion of these pictures as unquestionably the finest of the kind which have ever been produced, and it can be no derogation of Mr. Robinson's position as a first medallist, on so many occasions, for the best picture, to receive now the companionship of Colonel Stuart Wortley as first medallist for such a collection of pictures. We have since incidentally heard that Messrs. S. Thompson, J. H. Morgan, and Dr. Tressider each received a bronze medal. We should have been glad if Mr.

Sydney Hodges' letter had conveyed an official statement of the photographic prizes given, and their due relation. The communication of the gentleman who kindly undertook to furnish us with full particulars, has, through unfortunate delay or miscarriage, not yet reached us.—Ed.]

WANT OF INTENSITY IN TANNIN PLATES.

DEAR SIR,—A short time ago I met with a difficulty which was new to me in working with washed tannin plates; they would not develop to a sufficient degree of intensity, and became veiled during development. I found that the cause of the fault was the addition of too much ether to the collodion after evaporation by use. On the addition of about $\frac{1}{2}$ ounce of alcohol sp. gr. 805 to $1\frac{1}{2}$ ounce of the collodion, it worked satisfactorily, easily producing ample intensity, and developing much brighter. As I generally use a full proportion of alcohol, I was not before fully aware of the importance of keeping the proportion of ether as low as is consistent with working well.—Yours very truly,

C. RUSSELL.

Romford, Sept. 29th, 1863.

EDEN'S MICROSCOPIC CAMERA.

SIR,—I notice a communication in last week's PHOTOGRAPHIC NEWS, from Mr. Casartelli, of Manchester. It is quite true that I engaged Mr. Potter to make a portion of a small instrument for taking minute pictures to be used as microscopic objects, but Mr. Casartelli is well aware that it would not answer for the purpose. One reason was that the chemical and visual foci were not coincident, consequently it would sometimes take hours to adjust. Mr. Casartelli, after many vain and fruitless efforts to produce pictures as good and as cheap as Mr. Dancer's, abandoned its use in despair. My instrument is totally different from the one I and Mr. Potter constructed. The purpose for which I consider mine most useful is taking enlarged microscopic objects. The adjustment is simple and easy, and the chemical and visual foci being coincident, the most inexperienced can use it. If Mr. Casartelli likes to infringe the patent, he is at liberty to do so, as far as I am concerned, as I have sold my interest in it long ago; but I doubt if the gentleman who purchased it would allow him to do so with impunity.—I am, Sir, your obedient servant,

A. F. EDEN.

Walworth, S., Sept. 29, 1863.

A PHOTOGRAPHER'S RAMBLES.—LIGHT TRIPOD, &c.

MY DEAR SIR,—You will read the date below, and wonder where that is. Canandaigua is an inland village, about three hundred miles from New York, on a beautiful lake, sixteen miles long. The name is Indian, and signifies "a chosen spot." I am rusticated away from the heat and hum of the city. I am duly armed and equipped, of course, as a well-meaning amateur should be, with a Hughes' camera and changing box (the same one I got from Mr. Werge), and sixty extra plates. This I consider a fair supply for one month, as I seldom use more than eight plates during a day's walk, unless it is in some very wild and interesting locality, and then, as I never carry chemicals away from home, I find sixty plates are quite as many as I care to develop on my return. I was at one time enthusiastic enough to average twelve new negatives per day, but I found the negatives accumulated so fast as to drive away all hopes of ever getting pictures printed from them; and I have now in my boxes some negatives made a year ago that have not yet been in the printing frames. I intended to print and send to you, before I left home, prints from negatives taken with the Fitz lens and with the globe lens, but the preparation for departure prevented me, so accept my apology and the promise of them when I return.

We left New York by the Erie Railway, and made a stop

at Homer,—classic name! is it not?—Syracuse, Virgil, Rome, Manlius, &c., are all villages in the neighbourhood. I took my camera to Glenn Haven, a beautiful spot at the head of Skaneateles Lake, and after eating some roast corn and beef in the woods (our party built their own camp fires, and stole the corn) exposed a few plates. The great feature of this section of country is the "Bloomer" dress of the females. (I can't call them women, for they don't look so.) They do not wear the neat Turkish costume, tied at the ankles like those we are told of in the papers; you see no dainty little gaiter boot at the bottoms of silken extremities; no, no, they "wear the breeches;" but they are great ugly cloth breeches and *peg boots*. Only think of a "female human" in your or my broadclothes and boots, with a sort of French blouse reaching not to the knees. I made a demonstration to secure the portrait of a buxom fat girl in this rig, washing dishes at the kitchen door of a house, but she indignantly rushed into the house and slammed the door violently. I had been told that the Bloomer dress was becoming, and ladies proud of wearing it. That certainly did not look like it.

I am using a new tripod made of twelve pieces of gas tube $\frac{3}{8}$ th of an inch thick, and one foot long. These can be carried in a side pocket of a shooting jacket, or strapped with the camera over the shoulder. They screw together at the ends, and make a tripod four feet high, and perfectly firm. They are very convenient to pack away, and take very little space. The trouble of putting them together is, of course, a loss of time, but then, I keep mine set up all day, and shutting the three legs together, carry it with the camera and changing box on its head, in my hand, like a soldier's musket at "trail arms." This Hughes' box is a perfect arrangement, but he manufactures (or used to do so) it too frail, as the wood is so thin that a drop on a stone would smash it, and the rough usage a camera gets in America soon uses it up. My Hughes' box is already dilapidated, and a bottle of glue is my constant pocket companion. More anon.

—Yours respectfully,

F. F. THOMPSON.

Canandigua, N. Y., September 11th, 1863.

Photographic Notes and Queries.

THE FUMING PROCESS.

DEAR SIR,—I see in the NEWS of to-day a little more on the fuming process. I beg to state I have not declined the use of it, having constantly used it for the last two years. My mode of using it is as follows:—I dissolve 40 grains of silver to the ounce, and then precipitate with ammonia, and re-dissolve with nitric acid (I see it reads in the NEWS "re-dissolve with ammonia;" that cannot be right*), with just enough to make it clear; then sensitize for three minutes; then fume for fifteen minutes, in a kind of box I made myself, as follows:—2 feet 6 inches in height, 1 foot square. 4 or 6 inches from the bottom I have put a false bottom with perforations made with a half-inch centre-bit, which I find diffuses the fumes much better. Then I throw the paper on the said perforated bottom, and cover up for fifteen minutes. I find they are very sensitive, and of a cream colour, which does not interfere with the whites. The toning bath is much the same as stated in this week's NEWS, with the addition of a little carbonate of lime, and I find my prints are much richer, and, I believe, more permanent. Enclosed is a print, the first that comes to hand. You can report or not, and I would give any instructions, private or otherwise, as far as lies in my power.—Yours truly, W. H. FOX.

2½ and 50, Park Street, Bristol.

RETAINING THE SPECIMENS OF OPERATORS.

MR. EDITOR,—I wish to call your attention to a practice existing among master photographers of retaining specimens sent them for approval. Now, you are, I have no doubt, aware that they are not so free in allowing their operators to retain many good specimens, and I think it rather hard that those few should be kept.

* Yes; quite right.—Ed.

I advertised a short time since in the NEWS, and had several replies requesting specimens to be forwarded. I did so, and had the greatest difficulty in getting them returned, and one gentleman, not far from Whitehaven, has not condescended the slightest reply to my letter requesting that if not approved of, the cartes were to be returned.

I think a few words from you would cause an alteration.

With many thanks for the many pieces of information I have culled from your valuable paper, I am, Sir, yours, respectfully,

AN OPERATOR.

Greenwich, Sept. 22nd, 1863.

[The practice in question cannot, surely, be common; and is unquestionably most unfair and thoughtless. We think it would be wise to enclose with the specimens an envelope addressed and stamped, so as to leave no excuse on the score of trouble. Few persons would retain cards when such facilities for their return were afforded.—Ed.]

CHALK IN THE TONING BATH.

DEAR SIR,—Your correspondent's question has been answered by yourself; but he is in error when he thinks that I keep a sediment of chalk in the toning bath; I only do so in the concentrated solution, chloride of gold.

I always now use a bath for sensitizing paper made with 30 or 40 grains of silver per ounce, and 60 grains of nitrate of potash, which combination is equal in all respects to a 60 or 80 grain silver solution.—I am, dear Sir, yours faithfully,

Lgham, September 29, 1863.

WM. BARTHOLOMEW.

GUTTA-PERCHA NEGATIVE TRANSFERS.

SIR,—Permit me to refer again to this subject. It is very important to assist travellers, and even if imperfectly, to relieve them from the incumbrance of carrying much glass on a photographic excursion. Gutta-percha, after being some time in solution, deposits its colour. The solution, when used, must be applied strong, and when applied, the plate may be warmed, or the solution, after its application, may be warmed on the plate. A gutta-percha transfer looks shrivelled, like gold-beaters' skin, but when spread out flat and blown on, the creases disappear. If some members of our photographic societies would investigate the subject, many who may have to go a long distance may hereafter be thankful to them.

C. E.

TRANSFER OF FILMS.

I SEE, in your last Number, an inquiry about Mr. Archer's plan of coating negatives with gutta-percha, and taking from the glass. I believe that the principal objection to this otherwise convenient plan is, that in the course of a few months the gutta-percha becomes so brittle that the negative falls to pieces on being touched. Would the mixture of a little india-rubber with the gutta-percha keep it unaltered? The mixture is rather sticky until well dried.

C. RUSSELL.

[The preparation of gelatine and glycerine, recently described in our pages by Mr. Lewis, would probably be found useful.]

Talk in the Studio.

SOUTH LONDON PHOTOGRAPHIC SOCIETY.—Our readers who are members of this Society are reminded that the session re-opens on Thursday evening next, at the City of London College, Leadenhall Street. An opening paper, suited to the occasion, will, we understand, be read by Mr. A. H. Wall.

THE PATENT LAWS.—A striking illustration of the unfair working of the existing patent law was recently given in a judgment delivered by Lord Westbury in reference to the popular Ghost patent. After observing, in the course of hearing opponents to the patent, that he had seen the same principle applied very many years ago, he gave a verdict deciding that the patent should be granted in order that its validity might then be fully contested in a court of law! As to the fairness or unfairness of the patent, we offer no opinion, but surely this is only such a reason for granting a patent as would have occurred to the mind of a lawyer. In an article on the subject, the *Daily Telegraph* pays a handsome, and, we think, a well merited compliment to photographers. It says:—"If each improvement in photography had been at every stage fenced and hampered by patents taken out by successive

inventors, the art would have been strangled in its cradle. Fortunately, the photographers were as generous and unselfish as real men of science usually are, and photography became as free as the air we breathe."

SUBSTITUTE FOR YELLOW GLASS.—A correspondent sends us the following:—Some weeks ago I read in the PHOTOGRAPHIC NEWS of a substitute for coloured glass in the dark room. I forget, at the moment, the name of the gentleman who sent it, but whoever he is, he has my best thanks for publishing so useful a piece of information. I have a window in my dark room (that was) which I almost completely blocked up. When shut up, it was almost dark, and to be locked up in it many minutes was irksome. It was not long after reading the paragraph that I went to the colourman's and purchased the 2 tubes of colour, &c., tore down the old canvas outside the window and the yellow tissue paper that lined it inside (for such was my substitute for yellow light, it answered after a fashion), mixed my colours, and gave the six panes 2 coats in a day, for which the quantity just held out, at a cost of 1s. 4d., and truly can I say your correspondent does not exaggerate; the change from dreary darkness to a flood of golden light was enchanting. I felt quite afraid of exposing my plate in such a flood of light, but have now grown bold and can say it answers perfectly with the sun shining full on the glass; and I must tell you my process is iron development which won't stand fog. I am indebted for many useful hints to your valuable paper, and if you think my experience in this will be useful to your readers, pray use it." [The gentleman to whom our readers were indebted for the hint in question was, if we are not mistaken, Mr. Adlis, who was the unfortunate victim of a fire at the Portland Bazaar, by which he was a severe loser, and needs aid and sympathy.—ED.]

HYPOSULPHITE OF SODA.—In a paper on the manufactures of the district read at Newcastle, it is stated that the manufacture of hyposulphite of soda has largely increased of late years, and we believe in 1838 it was not made at all upon the Tyne. In 1854 the produce only amounted to 50 tons a year. It has gradually risen to 400 tons per annum. In addition to being used in photography, it is largely employed as an "anti-chlor" in papermaking, and from the Tyne the markets of Europe and America are chiefly supplied. In 1852 Mr. W. S. Losh obtained a patent for the manufacture of hyposulphite of soda from soda waste, which has been the means of greatly lessening the price, and consequently extending its application in the arts. On account of its greater stability hyposulphite of soda has nearly superseded the use of the older salt of sulphite of soda as an "anti-chlor," the latter being chiefly confined to sugar refineries as a deoxidizer. Dr. Jullien has recently obtained a patent for the production of hyposulphite of lime, to be used as an "anti-chlor," but it has not yet been introduced in commerce, the apparatus for its manufacture in course of erection at the Jarrow Chemical Works not yet completed.

To Correspondents.

- A. H. W.**—The first meeting of the South London Photographic Society's Winter Session will be held at the City of London College on the evening of Thursday the 8th instant. To become a member you must be proposed by a member. We shall have pleasure in proposing you.
- DEPOSIT.**—Your first difficulty is due to the glutinous character of the collodion; mixing it with a more fluid sample will remove the evil. 2. If you use the formula as you describe it in your letter, we think you are making an error. You state 2 drachms of iron, and 1 drachm of acetic acid to 20 ounces of water. Should it not be ounces of iron and acetic acid? We think that is what you mean when you ask "is not the developer very strong?" It is probable that by slightly decreasing the proportion of iron, and increasing the proportion of acetic acid, you will remove the tendency to the rapid decomposition of the solution which leaves silvery stains on the negative. But the decomposition you describe is frequently due to the condition of the nitrate bath. When it proceeds from this cause, neutralizing the bath by the addition of a little bi-carbonate of soda, sunning for a few hours, and filtering, will probably set it right. 3. We should recommend you to join the Photographic Society, and you will then receive regularly its excellent journal.
- FAIR PLAY.**—Qualifications for practising photography cannot be certainly gauged by the length of experience. Some persons practise for years without ever attaining great proficiency; others become good operators in a few months. Much depends upon natural qualities and previous education and habits. We cannot offer any opinion of the general fitness of the person in question, beyond what was expressed in our comments on his productions.
- HARRISON FRODSHAM.**—The proprietors of the *Illustrated London News*, *Punch*, and similar journals, unquestionably have a copyright in their engravings, and it is unlawful to copy them without acknowledgment. 2. We have not had any experience with the collodion in question. 3. The evaporation of the ether would leave your collodion thick and gelatinous,

but would not leave a "copious woolly precipitate." That looks very like the result of water having been added, which would throw down the pyroxyline. 4. If you mix all your residues together, liver of sulphur should be used to precipitate the silver from the solution as a sulphide. 5. Liver of sulphur is "a polysulphide of potassium." 6. When Mr. England spoke of recovering 40 or 50 per cent., he meant that proportion of the silver originally used.

- J. BUTLER.**—We are uncertain of the address; but the London agent is Solomon.
- W. CHILTON.**—The general design of your intended glass room is good, and if the exigencies of your material and position demand that it should be just as it is, it will do very well. As a matter of choice, we should have preferred the roof of the sitters' division to have been continued without an angle to the roof of division for the camera, and the glass as well. 1. We see no objection to the use of the asphalt felt, but have not had much experience with it. A friend of ours employs it for the covering of a dark room, and it answers very well. 2. We should prefer the triangular piece to be of glass, if equally convenient, as it is undesirable to have two distinct lights falling on your sitter; the side light and top light should, if possible, be a continuation of each other. 3. There is not too much glass.
- J. H. C. 42.**—You will find articles containing valuable information on transparencies in Nos. 139, 140, 188, and 208 of the PHOTOGRAPHIC NEWS.
- G. R. G.**—Place the background at the south end of your room. 2. The print received is pretty good; a little dark, perhaps, in the shadows, and, for our taste, a little too brown, otherwise it is good.
- E. E. D.**—Are you well assured that your bath contained no nitric acid? Any trace of nitric acid, Mr. Blanchard informs us, would decompose the glycerine, and cause fog. We have not had any experience in the matter ourselves, but have seen very fine negatives by the process produced by Mr. Blanchard.
- D. OWEN.**—The yellow tint of your photograph is, probably, due to the use of old and acid hyposulphite of soda, producing sulphur toning.
- D. S. SETTON.**—The chief fault in your specimens is a little tendency to black shadows. This would generally have been remedied by longer exposure. Your carpet is not sufficiently subdued. The vignettes are pretty good. No. 1 is the best, but the shadow on the retiring cheek is a little too heavy. A little more reflected light on the shadowed side of your figures, generally, would be an advantage.
- A. B. W.**—You have, by the free addition of acetic acid and carbonate of soda, formed a large amount of acetate of silver in the bath, which is a frequent cause of streaks and other evils. Try neutralizing with carbonate of soda, and leaving for several days or weeks in a strong light. If, after the filtering it does not work well, your only plan will be to precipitate the silver. 2. We do not know of any efficient card lenses which can be worked at a less distance from the sitter, than the one you have of Dallmeyer's.
- JOHN VANHEUR.**—We will write.
- N. H.**—There are good card lenses which will work in a distance of 15 feet. It would, however, be invidious to mention names here. You will find some mentioned probably in our advertisement columns; or, if you send us a list of names numbered, we can indicate a number.
- F. O.**—Your pictures have some very good qualities. The negatives would have been improved by a trifle longer exposure; and for vignettes it is desirable to use a lighter background. The only advice we can give you on the subject of a partner is to advertise in the PHOTOGRAPHIC NEWS. We cannot tell you the prices of advertisements; but our publisher will communicate with you.
- MICRO-PHOTOGRAPHS.**—MR JAGLIS, 90, Bolsover Street, London, informs our correspondent, John Davidson, that he can give him the information he requires regarding micro-photographs. We will be happy to hear from Mr. Jaglis on the other subject he named.
- AN ENQUIRER.**—A glass room twelve feet long is scarcely suitable for card portraiture, unless you are content to open the door and work with the camera outside. 2. The part immediately above, and at the sides of the sitter, should be opaque for a few feet, say from four feet to eight feet, according to circumstances. 3. We see no objection to placing the glass-house obliquely in your yard, in order to secure the light on your sitter, chiefly from the north. 4. From 10 feet to 15 feet high. 5. A person who has taken the portrait of the Prince of Wales by express permission may, we should think, use the words, "Patronized by the Prince of Wales," and, for anything we know to the contrary, use the emblematic feathers; but we cannot speak with certainty on this subject.

Photographs Registered during the Past Week.

- LOT'S KIESLING, Liverpool,**
Photograph—Group of Welsh Independent Ministers.
- MR. E. SMITH, 8, Old Bond Street, Bath,**
Photograph of the Rev. Dr. Stevenson,
Ditto of the Rev. J. B. Fleming.
- MR. NEWELL, Westmoreland Street, High Harrogate,**
Photograph of the Rev. J. H. Gavin, Independent Minister of Harrogate.
- MESSRS. W. AND D. DOWNEY, 9, Eldon Square, Newcastle-on-Tyne,**
Two Photographs of Dr. Cumming.
- MR. JOHN HAWKE, 53, Union Street, Stonehouse, Devon,**
Three Photographs of Dr. Spencer, Bishop of Jamaica.
- MR. AUGUSTUS MARALSKI, Goodlam-gate, York,**
Photograph of Captain Willett.
- MR. S. HOGGARD, Redcar, Yorkshire,**
Photograph of — Bolckow, Esq.,
Ditto of Mrs. Bolckow,
Photographic Group, consisting of — Bolckow, Esq., Mrs. Bolckow, Mrs. Charles Bolckow, Miss Bolckow, and Miss Allwesson.
Photographic Group, No. 2, of same persons.

Works for Review and Communications to the Editor to be addressed to 32, PATERNOSTER ROW.

THE PHOTOGRAPHIC NEWS.

Vol. VII: No. 266. — October 9, 1863.

CONTENTS.

	PAGE
The Use of a Lens in Printing	481
A New Photometer. By M. Malval	482
Scientific Gossip—The New Fixing Agent—Preparation of Sulpho-cyanides—Organic and Saline Impurities in Rain Water	482
Photographic Printing and Engraving. By William Crookes, F.R.S.	483
Carbon Prints on Plain Paper	485
A Few Thoughts about Photographic Societies. An Opening Address, by Alfred H. Wall, Hon. Sec., S.L.P.S.	486

	PAGE
Rapid Tannin Plates with Alkaline Development. By Thomas Sutton	489
Correspondence—Foreign Science—Formic Acid in the Developer	490
Microscopical Photography	490
Photographic Notes and Queries—Durability of Gutta-percha Transfers—The Discovery of Alkaline Development—The Earthquake	491
Talk in the Studio	491
To Correspondents	492
Photographs Registered during the past Week	492

THE USE OF A LENS IN PRINTING.

THE employment of a lens, used as a "burning glass" for concentrating the rays of the sun on some especial part of a negative in order to obtain augmented actinic action, has been frequently recommended; but rarely, we believe, practised. M. Guillaume has, we observe, recently revived the subject in an article in the *Revue Photographique*. As this article has been transferred into the pages of some of our contemporaries, we copy the translation, and add one or two cautions on the subject.

The chief advantage of using a lens in this way is found with an over-intensified negative, in which the face, it may be, or some other important part is so dense that the half-shadows and shadows become buried and black before the detail in the lights is sufficiently printed. The lens, skilfully used, to bring the direct rays of the sun to a focus on the dense parts, may, in such case, secure a good print from a negative which under other circumstances would only yield a worthless, hard, black and white picture. The principle once understood, it will readily be seen that by those willing to devote the time to the work many artistic effects may be communicated to the picture which are not in the negative. We have seen well-designed drawings, which had been executed on sensitive paper without a negative at all by Mr. Rejlander, simply using the light as a pencil.

But it is most important to remember, that when the sun's rays are brought to a focus by a lens, intense heat, as well as great light is produced. The lens becomes a burning glass; and unless great care be used, the varnish is melted, and adheres to the albumenized paper, and the negative is spoiled. Some time ago, we discovered this to our cost. We had used the lens with advantage before, and having a negative which we valued highly, although it was a little too intense in the face, we used the lens again to condense the light for a short time on the face. We used all the precautions which had before given good results, but this time the varnish, a perfectly hard one, melted, and the paper was stuck to the face, and although removed with great care, one of the eyes was irretrievably damaged. We had not taken into account one circumstance which modified the result. We had used the lens before, with a printing frame having a thick glass, through which the heat was a much longer time in penetrating to a dangerous extent. This time the negative was placed in the rabbet, in a small printing frame, fitting it without any glass over it, so that the focus or burning point was on the back of the negative itself, which was thin, and transmitted intense heat through to the film and varnish in a few seconds. It will be seen, therefore, that great caution should be used, when such an aid is used with a valuable negative. We now append M. Guillaume's article:—

It often happens that a negative, satisfactory in all other respects, but obtained under adverse conditions of light, yields prints which are hard and deficient in harmony. The high lights of the face become flat and white, while the more shaded portions do not acquire the desired amount of vigour. Increasing the exposure in the pressure frame, so far from improving, only serves to render more obvious the violent contrast of light and shade. Such a negative should be ruthlessly destroyed, rather than see the proofs it produces unfavourably received.

Frequently, also, in the portraits of ladies, linen, lace, embroidery, and such light accessories—the success of which gives such a charm to reproductions of this nature—being realized in the negative, only produce heavy white masses, the details in which, although visible by transmitted light on the glass, completely arrest the passage of light, which proves too feeble to determine the reproduction of these details on sensitized papers.

Under such circumstances, the greater number of photographers employ screens to shade those parts where the impression is imperfect. This expedient, besides being slow and difficult, does not accomplish the purpose for which it was designed.

The following is the method which we have often adopted, and which, in many cases, has enabled us to obtain with hard negatives proofs by no means deficient in softness and harmonious gradation:—

It is well known that a round magnifying glass, or any other lens, interposed between the solar rays and a plane surface, by concentrating the luminous rays, produces on the surface, placed at a convenient focal distance, an amount of light which causes the surrounding parts, although illumined by the direct rays of the sun, to appear, by contrast, feeble and dull. Now, when our pressure-frame, containing the negative and the sensitized paper is exposed, we furnish ourselves with a burning-glass, attached to a light metallic mount, by means of which we guide what may be called the *luminous point* to those parts of the negative most opaque to light, and in doing this we maintain a constant and uniform motion, so as to avoid the production of marks or lines; and the effect of this condensed light is sometimes so energetic that the most opaque parts of the negative, thus lighted, have acquired the necessary exposure before the more transparent portions are sufficiently printed. We have been able, in this way, to reproduce more delicate details than by ordinary light—details which would, in fact, have become lost in the density of the negative.

Moreover, by this process, vigour may be imparted to a feeble negative by directing the *luminous point* to those parts deficient in relief and modelling,—the shadows of the face, and certain details of drapery, for example. In a view, also, details may be brought out in the façade of a strongly lighted building or column, or other details of architecture or sculpture, which otherwise become lost in the opacity of the negative.

It is unnecessary to add that the *luminous point* must not be stopped for any long time in one place. The great heat produced at the focus of the converging solar rays, although having to pass through the thick glass of the pressure-frame, would affect the delicate collodion film. Finally, the force of the luminous ray may be regulated at pleasure by approaching or withdrawing the lens which produces it.

A NEW PHOTOMETER.

BY M. MALVAL.

WHEN *positive* photographic paper is exposed to daylight, the film of chloride of silver with which it is covered assumes a successive series of hues: pale lilac, deep lilac, light violet, deep violet, &c. It is upon this property of chloride of silver that the new method of photometry is founded. It consists in forming by a suitable mixture of colours a fixed hue identical with one of the hues produced by light upon chloride of silver. This fixed hue attained, it becomes easy to recognise, by comparison, the moment when the two hues are alike, and, in reckoning the number of seconds required to obtain this identity, we have in this manner a means sufficiently exact to appreciate the degree of chemical action in the light at any given moment.

In the application of this instrument to photography, in order to fix the time of exposure necessary to obtain a good proof, all the other conditions being fulfilled, we must determine the relation existing between the number of seconds indicated by the photometer and that recognised as necessary to properly impress the prepared surface in the camera, whether it be silvered plate, paper, or collodion. This relation being known will serve as a rule for all the proofs which follow, whatever be the intensity of the light. It is scarcely necessary to observe that we can admit only such proofs as are made in the same conditions, that is to say, with the same objective, the same photogenic preparation, and with the same distance between the objective and the object to be reproduced.

It is indispensable that only a newly-prepared and quite dry paper should be employed; if humid, it acquires in the light a reddish hue, which will not exactly agree with the fixed hue, and after being prepared several days it will acquire a yellow colour which is equally inconvenient. However, in making use of M. Marion's boxes for keeping paper dry in, we can use it after being kept a month, without any apparent modification in its colour or sensibility.

The only source of serious irregularity we can encounter in using the photometer consists in the preparation of the positive paper. We must therefore take the greatest possible care in its preparation, which presents no real difficulties. It may readily be conceived that by employing solutions of different degrees of strength we shall have very different results as to hue and sensibility. We should therefore lay in a good stock of paper, a ream, for instance, so as not soon to require a fresh supply, and it must be unglazed. The solutions of chloride of ammonium, and nitrate of silver, should also, for the same reason, be prepared in sufficient quantity. The following are the formulæ we have adopted:—

1. Bath of Chloride of Ammonium.

Filtered Water	100 parts.
Chloride of Ammonium	10

2. Nitrate of Silver Bath.

Distilled Water	100 parts.
Nitrate of Silver	15 "

Leave the paper for five minutes in contact with each of these solutions.

Whole sheets of paper would be too expensive to prepare; we therefore divide each sheet into four, or even eight parts. For quarter sheets the bath should contain at least a quart of solution, and for eighth sheets one-half that quantity. During the time this bath is employed for the photometric preparation it must not be employed for any other purpose. There are two little cylinders of the photometer for rolling the sensitive paper upon, previously divided into little bands of an inch in width, and to make it slide before the circular opening made in the centre of the fixed hue; but when we have to make several experiments, it will be preferable to divide the band of paper into little squares, which will be placed in the little box which accompanies the apparatus.

The preserving boxes for the paper (Marion's) must be selected without any addition of chloride of lime, as this substance, by the chlorine it gives off, removes from the paper a great part of its sensibility.

The sensitive hue appears more or less deep, according to the angle under which it is viewed. It is necessary, therefore, to place it always in the same direction, which is rendered easy by the aid of a small frame furnished with a screw, the intersection of which must correspond with the centre of the disc. The photometer must, also, always be placed vertically, and in such manner that its sensitive surface be parallel to the side from whence the light, or most of the light, proceeds. When the state of the sky varies at every moment, and consequently the light also, it will be useful to operate with the camera at the same time that we estimate the duration of the exposure necessary to the proof. The following are the means to be employed:—To prove that the time of exposure must be less than that indicated by the photometer, we bring the latter to the side from whence the light proceeds, and we may discover by a few trials, the point at which the two operations require the same amount of exposure. This point is the same for all the other proofs made under the same conditions, a greater reduction of the model, the employment of a more rapid objective, or of a more sensitive preparation, naturally necessitate new trials.—*Bulletin de la Société Française.*

Scientific Gossip.

THE NEW FIXING AGENT.—PREPARATION OF SULPHOCYANIDES.—ORGANIC AND SALINE IMPURITIES IN RAIN WATER.

THE days of hyposulphite of soda seem to be numbered. A safer and, we think, better fixing agent is rapidly rising in scientific opinion, and there is every probability that it will, before many weeks are over, be introduced into the market at a price which will admit of its being experimentally tested on a large scale. Sulphocyanide of ammonium, the coming salt which is to regenerate photographic printing, and cause a faded positive to be unknown except as a thing of the past, is now attracting the attention of many large chemical manufacturers, one of whom is now erecting the necessary plant to enable him to turn out upwards of a ton a week of the perfectly pure crystallized salt; the wholesale price of which, in quantity, will not much exceed a shilling or fifteen-pence a pound. The process of manufacture we are not yet at liberty to divulge; but we have had it thoroughly explained by the manufacturer himself, and we feel justified in stating that it is one of the most beautiful applications of chemical science to the utilisation of waste products. The chemical reactions involved in the manufacture are very definite, and perfectly accomplish the desired result. We have also been favoured with samples of the product. It is beautifully white and crystalline, and contains no appreciable trace of impurity. The original source of the cyanide of ammonium is the thick tarry liquid remaining after the separation of the free ammonia from gas liquor; this has long been known to contain large quantities of sulphocyanide of ammonium, but, hitherto, all attempts to separate it from the impurities which accompany it have failed.

It is somewhat remarkable that the fixing agents already in use, hyposulphite of soda and cyanide of potassium, should be closely related chemically to the new agent sulphocyanide of ammonium. By heating together cyanide of potassium and hyposulphite of soda, the latter fuses in its water of crystallization, and remains liquid until all the water is driven off, the cyanide meanwhile remaining unacted upon; when, however, the hyposulphite is completely dehydrated, reciprocal decomposition of both salts takes place; the mass becomes somewhat brown, a little decomposition and loss of cyanogen occurs, but the greater part of the cyanogen unites with the sulphur to form sulpho-

cyanogen, which, combining with the soda present, forms sulphocyanide of sodium. In order to obtain the best result, the heat has to be attended to somewhat carefully, for, if too great, the sulphocyanogen itself is decomposed, whilst if, on the contrary, it is not sufficient, proper decomposition of the hyposulphite does not take place. After the fused mass is allowed to cool, it may be powdered and heated with alcohol; this extracts the sulphocyanide of sodium; probably a slight modification of the process, and the introduction of a salt of ammonia, would enable pure sulphocyanide of ammonium to be formed directly; but the process in any case is only of scientific interest, as showing the great relationship existing between the old and new fixing agents, for the expense would be very considerable.

The expensive cyanide of potassium may be replaced by the cheaper ferro-cyanide of potassium. Upon heating this with hyposulphite of soda, a somewhat similar decomposition takes place to the one mentioned above; and upon this reaction a very easy method of preparing sulphocyanide of sodium or potassium has been devised. One part of ferro-cyanide of potassium, and three and a half parts of hyposulphite of soda, are well dried and mixed together. The mixture is heated in a porcelain dish until the hyposulphurous acid is decomposed. The sulphocyanide is extracted at once from the doughy mass, by means of hot alcohol; or the mass may be left to cool, then treated with boiling water, and the sulphocyanide separated by crystallization. Sulphocyanide of potassium may be prepared in a similar manner, by fusing one part of dried ferro-cyanide of potassium with three parts of dried hyposulphite of potash.

We have on many occasions urged the necessity of photographers who use rain water testing it for organic matter, before use, by means of a weak solution of permanganate of potash, which will be discoloured unless the water be perfectly free from this impurity. The subject of rain water has recently been examined with great care by M. Robinet. He has collected and examined the water falling in Paris, during the last eighteen months, having made a hundred and eighteen observations. He found the water always more or less charged with saline matter, the larger quantities always being found after prolonged drought. On collecting the water during continued rain he found that the amount of fixed matters diminished as the rain continued; showing that the saline impurities were derived from the atmosphere, and from the road-dust accumulating upon the roof in dry weather. The saline matter was principally sulphate of lime, always accompanied by a little organic matter. The amount of sulphate of lime is sometimes rather considerable. The organic matter present is not thoroughly understood, it causes the rain water to froth on agitation more than any water which M. Robinet compared with it. On adding a solution of nitrate of silver to the rain water, various shades of red were in time produced, forming, on standing, a reddish deposit which contained silver. The exact nature of the substance which produces this colouration is not yet known, but it will be the subject of future experiment. It has long been known that rain water contains organic matter, and it has been assumed that the presence of this organic matter must necessarily be injurious to photographic processes in which it is introduced. Here, however, we have a positive confirmation of the accuracy of these surmises, showing more forcibly than anything we can say, the necessity of only employing rain water which has either been proved to be free from organic matter, or which has been purified from it by permanganic acid, in the manner described in these pages some few weeks ago.

PHOTOGRAPHIC PRINTING AND ENGRAVING.

BY WILLIAM CROOKES, F.R.S.*

THE uncertainty which is a necessary accompaniment of the ordinary method of photographic printing, its great expense, the extreme difficulty of producing a sufficient number of presentable pictures of the same subject to satisfy the requirements of book-illustration, and the utter impossibility, in the present state of our knowledge, of procuring a photographic print which can be relied upon for permanency, have caused men of science to turn their attention, from the earliest days of photography, to the problem of causing the photograph to impress a metal plate or lithographic stone, in such a manner that the subsequent copies could be struck off in printer's ink.

A somewhat similar problem, but one of far less utility, has been to produce photographic prints on paper, prepared in such a manner that the dark portions of the image should be composed of carbon, or some other body of which it can confidently be asserted that no ordinary atmospheric influences would cause it to change. This latter problem has been followed up with some ingenuity by many experimentalists, both in England and on the Continent; but as they are all open to the grave objection that the mechanical operation of printing is as slow and uncertain as the ordinary process, they need not be further alluded to.

Passing rapidly over the first rude attempts of Donné, Niéce, Berres, Fizeau, Nègre, and perhaps some others, none of which met with much success, we come to the photographic process of Talbot, the basis of which was first published in the early part of 1833. The principle which he adopted was an entirely new one in that branch of the art: it may be briefly explained as follows:—A solution of gelatine or isinglass, containing a little bichromate of potash, is poured on to a steel plate and allowed to dry. If one-half of the plate is covered with a piece of card so as to obstruct all light from it, and the other half exposed to the action of sunshine for a minute or two, it will be found, on examining the plate in a dark room by the light of a candle, that the portion which has been exposed to the sun has become of a brown colour, whilst the shaded part of the plate remains of the original yellow tint. This is a well-known photographic property of bichromate of potash, and was long before applied by Mr. Ponton to the purpose of printing photographs on paper. But, besides a change of colour, another alteration will be found to have taken place. If dipped into water, the gelatine and bichromate of potash which has not been acted upon by the light will gradually dissolve, and leave the steel surface quite clean; but the other portion which has been turned brown by exposure to the sun's rays will scarcely dissolve at all. If, instead of a piece of card, the leaf of a fern, a piece of lace, or the light feathery flower of a grass, is pressed in contact with the prepared surface of steel by means of a thick piece of plate-glass, the finest line, and even the minutest fibre or thread, will be copied on to the steel surface, and, after being washed with water, will show an eminently beautiful white image impressed upon a yellowish-brown ground. The next step in the process consists in etching this steel plate in such a manner that an impression of the object can be struck off in printing ink. This is a matter of more difficulty than would at first sight be imagined; many chemical agents are known capable of attacking the exposed surface of the steel plate, whilst they will have no action on the parts protected by the altered gelatine, but a plate so etched will not give a good impression, except under very favourable circumstances. If the negative has been a piece of black lace, the finished and etched plate will have a perfect representation of the lace

PHOTOGRAPHY AND THE SOCIAL SCIENCE CONGRESS.—We understand that MM. Edmund Potonie and Radoult, of the *Comptoir International des Photographes*, are about to publish photographic portraits of the members of International Social Science Congress. They will be published simultaneously at the offices of the Comptoir in London, Paris, and Bruxolles.

* *Popular Science Review*. This interesting article, by Mr. Crookes, is illustrated by a photolithographic copy of a page of the *Times*, in a space of 3 inches. It has been photolithographed by Messrs. Kider and Preston—the first-mentioned gentleman having been one of those engaged in connection with Colonel James, in the Ordnance Map Office, at Southampton.

eaten into its surface, to a considerable depth, by the action of the corrosive liquid, and if this be given into the hands of a copper-plate printer, he will, in all probability, produce very beautiful and perfect prints, which at a little distance could not be distinguished from the original lace.

The perfection of this kind of subject is due to the lines of etching formed by the threads of lace being of such a diameter that the ink is properly held by them; but if, instead of a piece of lace, a photographic picture were used, a very different result would be obtained. The steel plate, it is true, would be impressed with an exquisitely beautiful image, and upon applying the etching liquid, the picture would be bitten in with tolerable accuracy; but when tested by the printing press, the plate would be found sadly deficient. A careful examination will show where the fault lies. Where the light has acted strongly the plate is not etched at all; where the light has not acted, the plate will be corroded very deeply, and if this portion represents fine lines, such as the branches of a tree, or a row of palisades, the ink will be held by them, and produce a good print; but, if a surface of the plate is etched in this manner, there will be no means of holding the ink, and that portion will not, therefore, give an impression. Again, a half-tint will be represented on the plate by an uniform corrosion of the surface to a slight depth; but, for printing purposes, half-tints of various degrees are required to be represented by lines or dots of different distances apart.

This difficulty besets all processes for photographic engraving; pure black and white can be given easily enough, but the half-tints, which constitute nine-tenths of a good photograph, have puzzled many experimenters to master. Talbot partially overcomes this difficulty, by producing an artificial aqua-tint ground on the plate, either by impressing it with the image of two thicknesses of black lace crossed diagonally, or by spreading very evenly over the surface of the plate a little finely-powdered gum copal, and then, treating it in this manner, the ink is enabled to adhere to those portions which constitute the half-tones of a picture; and by adopting either of these artifices, the photoglyphic process, as Mr. Talbot terms it, has yielded results which, in the hands of a skilled operator, and on small plates, can scarcely be surpassed.

The photogalvanographic process of Pretsch is somewhat similar in the commencement to the one just described. A plate of glass, or any other smooth surface, is coated with bichromate of potash and gelatine, and then exposed to the light under a photograph or an engraving; it is then moistened with water, but not thoroughly washed. The first action of moisture is to cause those portions of the surface which have not been exposed to the light to swell and rise up, more or less, in ridges from the surface of the plate. A mould is then taken from the plate so raised; from that an electrotyped copper plate is procured, which is used as a matrix, from which other plates may be produced suitable for printing purposes. The gelatine, in swelling, is found to split up into ridges, giving to the whole surface a granular effect, which holds the printing ink equally well in the fine lines and the broad masses of shadow. This process gives very effective prints when they are large, and viewed from a distance; but for fine, delicate work it is not so successful.

Another process has been brought to considerable perfection, by Sir Henry James, in the Ordnance Office, Southampton, where it is used for producing copies of maps. A mixture of gelatine and bichromate of potash is in this case also the foundation. A surface prepared with this mixture is exposed to the action of light behind a transparent picture of the map, or other object to be copied, which is tightly pressed against it. The change which has been already described takes place, and now a roller charged with lithographic ink is passed over its surface. This blackens the whole, but when it is soaked in warm water, those portions of the sensitive surface which remain unchanged by the action of the light are dissolved out, and

the lithographic ink is thereby removed from those parts of the picture. A prepared flat surface of zinc is then placed in contact with the inked picture, and the two are submitted to heavy pressure, when a complete transfer of the picture will be found on the zinc. After suitable preparation any number of copies can be printed from this zinc plate in the ordinary printing ink. This process is capable of giving very perfect results, and when applied to the reproduction of manuscripts, prints, or similar matter, it is impossible to conceive a more perfect reproduction. Indeed, it is no easy matter, when the original and the photogalvanographic copy are placed side by side, to distinguish one from the other; and if the copy has been reduced in size by the photographic means, most persons would prefer it to the original both in point of delicacy and sharpness.*

The last process with which it is necessary to treat, is the invention of Mr. Dallas. No explanatory details are given by the inventor, but there is little doubt, from the results already exhibited, that it is a modification of one or both of the photoglyphic and galvanographic processes. The great difficulty has always been to retain the half-tones. Mr. Talbot's process, it is true, solved this most perfectly. Before us is a print representing a portion of the palace of the Tuileries. The richness of the sculpture, the number of the statues, and the numerous fluted columns render this an exceedingly difficult subject to engrave by a chemical process, owing to the great variety of tints which it represents; and it affords ample evidence that this kind of photoglyphic engraving is capable of rendering the most delicate gradations of tone, and the accurate delineation of details as perfectly as the bolder outlines of the picture. Confining the scrutiny to certain portions of the picture, the effect is quite equal to any photograph printed in the ordinary way, which is giving it the highest possible praise; but when the picture is viewed as a whole, it appears patchy and unevenly developed. Owing to the difficulty of overcoming this defect, photoglyphy is now but very little heard of. Mr. Dallas seems in a great measure to have succeeded in overcoming this want of evenness, and has produced pictures which, regarded as a whole, must be considered very satisfactory specimens. They will not bear microscopic examination, as do many of Fox Talbot's, but, as pictures, they are much superior to any untouched specimens produced by either of the processes alluded to.

An art like this is still in its infancy. As soon as a method of photographic engraving comes into general use for book-illustration, improvements will follow one another rapidly; the faults above pointed out are, in a great measure, due to inexperience or defective manipulation, and would vanish as soon as a demand arose amongst the public for such illustrations. The general adoption of a process of this kind would be invaluable; an engraving of any object or scene, however good the artist might be, is not, and cannot be, an exact representation; at the best it is but a mere approximation to that, and there is always a tendency for the artist to idealise the subject and render it difficult to recognise at first glance, or he will not descend to those minutiae of detail which give such a charm to the photograph. The great value of photography is that it produces absolute *fac-similes*; but this value is lessened by the tedious rate of reproduction, and the great probability that in twenty years' time upwards of ninety per cent., of the photographic prints now in existence will have faded out. By wedding engraving to photography, and making the same physical agencies which impress the sensitive tablet produce the engraved plate, the mathematical accuracy of form and detail possessed by the photograph is secured, united to the permanence of a printed book.

For the illustration of objects of natural history, flowers, plants, and animals, even to the most minute microscopic

* Mr. Crookes appears to have overlooked the labours of Mr. Osborne, one of the most energetic and able of photolithographic discoverers.

object, this invention is invaluable. By its means *fac-similes* of rare engravings or manuscripts are even now, as in the case of "Doomsday Book," multiplied to any extent, and circulated amongst the public at a price which formerly would not have been paid for the commonest woodcut.

CARBON PRINTS ON PLAIN PAPER.

MR. WILLIAM BLAIR, of Perth, to whom, as we recently intimated, the original idea of obtaining half-tone in carbon photographs, by printing through the paper, is due, has described, in the *Photographic Notes*, a new method of obtaining carbon prints on plain paper. After some preliminary remarks congratulating Mr. Pouney on his results, he remarks that he is still convinced, however, that all prints upon oiled, or waxed, or varnished paper, will have many disadvantages. He adds:—

"They lack the freshness and vivacity of prints on plain white paper—there is a difficulty in mounting them properly—and they cannot be easily tinted in water colours. I therefore believe that many will prefer to work the simpler processes which I am now about to explain."

He then proceeds with his own process as follows:—

"First, Take a sheet of good white homogeneous paper, softly sized, and as smooth as possible on the surface—I have found some specimens of well-pressed common scroll paper answer wonderfully well; gelatinize the smoothest side by floating for a minute or so on a dish of diluted warm gelatine, mixed with a little common salt. If the dish has a smooth level edge, draw the gelatinized side of the paper over the edge with a slow, regular motion, or over a smooth fixed roller conveniently attached, so as the better to equalize the gelatine, and carry away air bubbles, which must always be got rid of. Then hang it up to dry, or throw it on its back and let it dry, in a place protected from dust. This should be done with a large number of sheets successively, so as to use up the gelatine while it is fresh and in good condition.

"Second, Take a quantity of albumen and put into it a very small quantity of syrup and a very little water. Then consider what tone or colour you would like your prints to assume in the middle shades. If landscapes, perhaps a blue tone would please (and blue at this stage has an advantage which I will afterwards refer to), in that case take a cake of Prussian blue or indigo, or if you wish a warm tone, say for a building or a portrait, take red lake, or burnt sienna, or any fine *transparent* water colour, or mixture of colours you please; or if a plain black is desired, use fine china ink, and rub or grind this down among your albumen in such quantity that, when spread on paper with a brush, it will give a good depth of half or middle tone. Beat the whole to a froth, and let stand till the albumen settles, then pour off into a small bottle for use.

"Third, Obtain or prepare very fine dry carbon, free from grit or oiliness, and keep it for use in a wide-mouthed phial. It may be mixed with burnt sienna, very finely ground, or any other permanent semi-transparent colour which has not a metallic base, if you wish to modify the tone of the carbon.

"Now proceed with the preparation of your paper as follows:—

"Take one of the gelatinized sheets, lay it on its back for a few seconds on the surface of a dish of water (gelatine side upwards) till it lie flat, then take it up by two corners, let it drain for a moment, or place it back down on blotting-paper, previously damped and pressed, to liek up the superfluous moisture; then lay it, back still down, on a sheet of dry glass, somewhat larger than the paper, and pour about as much of the coloured albumen upon the paper as can be spread thinly over the whole surface of the gelatine, with a soft camel-hair brush, and spread it accordingly. Don't mind though part should get frothy, the next operation will clear that away. Then take a large broad soft hog's-hair brush and sweep very gently in all directions, so as to carry

off from the surface, over the margin, all superfluous matter, taking care not to press so heavily as to disturb seriously the gelatine beneath; leave off before the surface has dried to tackiness. The sheet should then present a fine uniform transparent surface in half shade when viewed by reflection, but when viewed by transmitted light, should appear very little darkened by the colouring matter. Take care of dust in the brushes, or from any other source. Lay the paper aside to dry, and treat the whole batch in the same way.

"You may have albumen of different tints, so as to get any desired variety of tone in the same batch of paper.

"Both after gelatinizing and albumenizing, it is convenient to put the paper, when dry, into a blad or large book, that it may assume sufficient flatness to be easily handled, and spread again on a dish of water without air bubbles.

"Next comes the carbonizing; and this, though simple and easily managed after a little practice, requires some care, and even expertness in certain conditions of the paper, to get an even coating. The paper must be damped on the back, but the secret is to take care that it is not *too* damp when the carbon is laid on.

"Take a sheet of your tinted paper, lay it carefully, back downwards, on water for a few seconds, avoiding air bubbles. Quickly lift the one end half out of the water, and then the other, dispersing any air bubbles with a brush—if not quickly dispersed, they will cause blank or whitish spots on the upper surface afterwards—then lift the sheet off the water, lay it down on damped blotting paper, previously pressed level, or on glass, back still down, and with a sheet of dry blotting paper above, level it well down, so that the moisture on the back will be equalized. This must all be done quickly, the success of the carbonizing depending much on it. Then pour a quantity of dry carbon on the surface of your paper in a small heap, and with a large, soft camel-hair brush, thoroughly dry, distribute the carbon very quickly over the whole surface, leaving about half an inch of margin all round untouched, in case of the brush coming in contact with any water that may have come round the edges from the back. Brush all the carbon that does not adhere to the surface towards the one end, in a small heap, and return it to the bottle, then continue for a short time brushing gently in all directions, so as to drive the carbon slightly into the albumen, and sweep away with the brush all that is not adhering to the paper. If this is properly done, a fine uniform semi-transparent surface should be presented, and yet of sufficient density to form the darkest shades necessary in a picture. By holding up the paper and looking through it against the light, you will at once be able to judge of its fineness and uniformity, and if it is not quite uniform and semi-transparent, but clouded with dark spots, endeavour to manage the next sheet better. This is a mere matter of mechanical dexterity, but on which the fineness of the ultimate result greatly depends.

"What I have now explained is the most troublesome part of the process, but in reality it is simpler than at first sight it would seem from the above minute mention of particulars. Fortunately, all this can be done in broad daylight, and what I wish to call particular attention to, is that up to this stage the paper could be prepared and sold by manufacturers, ready for use, just as collodion or albumenized paper, and other photographic materials, are prepared and sold at present. Had every one to prepare his own collodion, it would probably deter me and many others from attempting the use of it.

"The next stage is the sensitizing. This is very simple. Have a saturated bath of bichromate of potass, about two parts water, and one part common commercial acetic acid—the acid makes the bath penetrate the paper more quickly. Lay a prepared sheet, back down, on the surface of this bath (in the dark room, of course), avoiding air bubbles as before. Allow it to float for half an hour or an hour, according to the quality of the paper, till the bichromate has well penetrated to the upper carbonized surface, but not till the paper is soaked. The paper should be least sensitive on the car-

bonized surface, and increased in sensitiveness internally towards the back, inversely to the action of the light, as afterwards explained. Then hang up to dry in the dark.

"EXPOSE.—Lay your paper in the pressure frame, with its black or carbonized surface next the negative film, and expose in the usual way in good sunshine. Sunshine is not absolutely necessary, especially with weak negatives, but as a rule I think it is best, from its power of penetrating the paper, and more easy calculation of the proper time. In sunshine you will require to expose from five to twenty minutes, according to the density of your negative. Your negative should be as dense as to require about ten minutes at least. When examined on removal, a very decided impression should be seen by looking through the paper, not of course visible in the finer details, otherwise it is probably over-exposed, and will be troublesome in the washing up.

"WASHING.—Begin with cold water, and let steep for a short time, say twenty or thirty minutes, then come over the surface gently with a broad soft brush. If the carbon does not appear to yield any in the high lights, pour in a little warm water and try again with the brush, and so on, increasing the heat of the water to a moderate extent, and trying the brush. If rightly exposed, the picture should gradually clear up under the softening of the water, and the gentle friction of the brush. The brush should not be used with any violence, but simply to remove more speedily what the water has already softened or dissolved. Sometimes, indeed, when the picture has been over-exposed, I have used the brush with considerable pressure, and even a sponge in some parts, without spoiling the picture; but as a rule violent rubbing is incompatible with obtaining the finer half shades.

"A little acetic acid or liqueur ammonia, mixed with the water, will facilitate the dissolving of the albumen and clearing up of the picture, when there is any great delay from over-exposure. The last washing should be in clean water, and the picture is then dried. If any of the details are lost in the washing through under-exposure, or too violent rubbing with the brush, the picture may still form a good groundwork for water colours.

"Paper prepared as above directed, will, before sensitizing, keep for any length of time; also after sensitizing it will keep for a considerable time, and yet produce tolerable pictures; but I am of opinion that the quality of the picture depends a good deal on the exposure and washing being carried through within a moderate time after sensitizing. Indeed, I am inclined to think that for the best pictures the paper should not be allowed to become *bone dry* before exposure, as the bichromate has then a tendency to crystallize and produce a granular effect; but the syrup mixed with the albumen has a tendency to retard this result, and give greater latitude. The syrup, also, besides rendering the albumen more tacky to attach the dry carbon at that stage of the process, makes it afterwards more easily dissolved in washing up the picture, and it is important, as will afterwards be seen, that the carbonized surface which is exposed to the greatest light should be more soluble than the gelatine beneath, which is to support the half-shades.

"The salt in the gelatine disposes it to absorb moisture quicker from the back of the paper, during the different operations above described.

"The sensitizing the paper from the back is convenient, as it does not disturb the carbonized surface, which would easily be washed off. But it is important in another respect which has already been indicated, but which will appear more plainly on now considering how far the above process is right in theory.

"In January, 1859, I first announced through the *Notes* the result of my printing in carbon on plain paper by placing the back of the sheet against the negative, and this was considered an improvement at the time, though its importance was not fully recognized, and I had not a sufficiently transparent medium to do justice to the carbon. I afterwards tried waxed paper however, and was further satis-

fied that the theory I had formed was correct, as the granulation was considerably reduced. In 1861, I recognized the same principle as being involved in M. Fargier's plan of printing on the black surface, and preserving that surface by transference to another sheet; and I wrote a letter in defence of his plan, and of my own, which was published in No. 117 of the *Notes*. In that letter I stated pretty fully my views on the subject, maintaining that the different gradations of shade arose from the different depths that the light penetrated into the carbon; that the true picture, as thus hardened and fixed, was always on the sunned side, and that that side should be preserved. This is now acknowledged to be sound, and Mr. Poncey is acting upon that plan.

"Well then, it may perhaps, at the first glance, be thought that the method of printing which I am now recommending is at variance with the above theory, but it is not so. It is founded on the recognition of that very theory, and deviates from it as little as circumstances will permit. It is true the exposure is reversed; the negative is placed direct against the carbon surface, and the carbon surface first receives the light, and that surface is not entirely preserved, but is in part washed away in getting at the picture. But just because the process is thus far reversed, I have endeavoured to meet this reversal by a series of compensations, the working of which will be understood on a little consideration. In the first place, the carbon coating is laid on so thin as to remain very transparent, and thus to interrupt as little as possible, especially in direct sunshine, the passage of the light to the interior of the paper. In the second place, I have recommended a transparent *blue* colour below the carbon, as being more actinic and easily impressed with the little light that reaches that region. In the third place, I have placed gelatine next the paper, and mixed albumen and syrup next the surface, the latter being comparatively more easily dissolved in cold or lukewarm water than the former, which is the support of the finer half-shades. And, fourthly, I have sensitized from the back of the paper, so that it is a mere filtering of the bichromate that reaches the carbon surface, and the sheet thus prepared is not so sensitive on the carbon surface, which receives most light, as it is in the interior, which receives comparatively little light, thus compensating by sensitiveness for the weakening of the light as it reaches the material which is to form the half-shade. By this arrangement the interior is hardened about as speedily as the surface, and the result is much the same as if no blackening were on the surface, but the whole sheet equally transparent and equally sensitive, in which case it would evidently be immaterial which side is exposed to the light. Such appears to me to be the extent to which this process is right in theory, and it is corroborated, I think, by the results I have obtained.

A FEW THOUGHTS ABOUT PHOTOGRAPHIC SOCIETIES.

AN OPENING ADDRESS, BY ALFRED H. WALL, HON. SEC., S.L.P.S.*

I HAD been looking thoughtfully over the reports of the various photographic societies, when it struck me that institutions exercising so important an influence upon the wellbeing and progress of the photographic art-science, ought themselves to be a matter of earnest consideration. As this, the first evening of our new session, drew near, I began in the performance of my duty, as secretary, to cast about for some one or more good and interesting papers to be read thereat, and finding it difficult to procure them in time for that occasion, resolved that I would myself prepare a paper, taking for my subject such societies as we now represent. As I am going to speak very honestly some of the thoughts I entertain on such a subject, I must begin by requesting you to remember that I shall speak of such

* Read at the South London Photographic Society, on Thursday, Oct. 8th.

societies generally, and have no intention of particularising either this one or that.

Photographic Societies are not readily appreciated by strangers. Their aspects are so various, that it is only by frequent visits to their ordinary meetings that you can understand them. The range of subjects which comes under attention for discussion thereat are such as, until the introduction of photography, were seldom associated together. The rules of art, the laws of chemistry, the principles of optics, and the secrets of certain mechanical crafts, seem in the non-photographic mind to possess so little in common, that strangers wonder when they hear each, or all, of these dissimilar subjects blending in a discussion following some paper on one or other of the processes of photography. This is very apparent in glancing over the reports of such societies in the photographic journals. Now they appear like societies of fine art students, enthusiastically dwelling upon æsthetics; and anon you could imagine them congregations of unpretending cabinet-makers, every man with a six foot rule in his trousers-pocket, and a big square lead pencil in that of his waistcoat. Again they show like learned chemists, investigating the hidden mysteries of nature, and reducing to their elements every component portion thereof; and yet again they show like grave opticians, ready at the shortest notice to chalk you in white lines upon a black board any number of eye-confusing diagrams, which, to the uninitiated, shall resemble nothing but the ramifications of a spider's web, or the intersecting routes of all the various railways in the three countries of England, Scotland, and Ireland.

In consequence of this blending of seemingly inharmonious elements, photographic societies are, or should be, composed of photographic artists, chemists, opticians, mechanics, and operators; the latter title, in some cases—so accomplished are many photographers—comprising, perhaps, all the others; and from this fact arise certain features peculiar to such societies, some of which are admirable, and others of which are—well—not altogether so. The former being represented by the benefit which always ensues from the bringing together, and comparing of views taken from different stand points, and the latter arising from the exposition of crude ideas on subjects in which certain members may be deeply interested, but in which they are certainly not deeply learned. In this case, of course, the good and its reverse must be taken as we take light and shadow in nature; only for the sake of the public reputation of such societies, it would be well if their reports should either be drawn up by such accomplished gentlemen as are tolerably well informed on all these subjects, or submitted previous to publication to a competent and fairly representative committee of the society concerned.

I next, rather hesitatingly, venture upon some few remarks on another peculiarity of photographic societies. It is a peculiarity with which, as readers of the photographic journals, we are, unfortunately, not unfamiliar.

It is no very difficult thing to join a photographic society. You have but to send your card to a member, or to the secretary, or to the editor of your favourite photographic journal, and the thing is done. It is not asked that you shall have attained any fame in any particular branch of art or science associated with or having a bearing upon photography. It is not required that you should be a photographer, either amateur or professional. You are elected to the tunes of "the more the merrier," and "no questions asked." Being elected, you speak at the society's meetings, and afterwards read your name and utterances in neat black print, conscious the while that your words are travelling into foreign lands, and that your name will be seen of men afar off. So it sometimes happens that members who have nothing to say, and are very ambitious of saying it, write it out at great length in more or less elaborate papers, which they are kind enough to read before our photographic societies. That every now and then a gentleman who has mysteriously and suddenly become deeply scientific, instead of seeking distinction in other quarters,

brings forward his startling and very original theories for the enlightenment of photographic societies, and that youthful photographic aspirants come confidently forward at their meetings to describe at length full-length feats of skill only to be equalled by that of the undying Homer—

"He who with philosophic eye
Sat brooding o'er his Christmas pie,
Then, firm resolved, with either thumb
Tore forth the crust-enveloped plum,
And, mad with youthful dreams of future fame,
Proclaimed the deathless glories of his name!"

The evil of all this is, that it gives the enemies of our societies the means of ridiculing them; that, by lowering their tone, it makes men of really high attainments in art and science hesitate about joining them, and that it thus operates against the permanent usefulness of such societies, by excluding elements upon which they are dependent for thoroughness and stability.

To meet this difficulty it is only necessary that the officers of a society should insist upon receiving the MS. of all papers proposed to be read before such society at least a fortnight previous to the night of meeting.* Of course, this could not be done without the co-operation of the members generally. Of course, also, there are contributors of papers whose names would sufficiently guarantee the character of any communications they might feel inclined to honour a society with; but these gentlemen being generally only too desirous of benefiting and elevating the art-science, would surely not refuse compliance with a rule intended for such an end, it being obvious that to avoid an appearance of anything invidious the rule must be applied to all.

Among other advantages which this rule would ensure, would not only be the raising of the character of a society's proceedings, but the certainty which its members would feel, accidents notwithstanding, of always finding a paper, or some other interesting subjects of discussion, prepared for them,† and the consequent increased regularity of their attendance. Under the regulations, or, rather, want of regulations, now adopted, the members of these societies frequently come through inclement weather many miles from home, only to find a bare, empty, comfortless meeting, and a chairman full of regret to say that no paper had been provided.

One of the most legitimate means of encouraging and propagating a spirit of enterprise and improvement has been found in awarding honorary distinctions, such as medals, for excellence of production. I think several of our photographic societies have done well in recognizing this, and I would recommend the adoption of this practice to such as have not yet adopted it.‡ It was one of the first means by which the Society of Arts did us so much service by initiating a new era of progress in all the arts, the fine arts not excepted. But in making such awards, the most scrupulous care should be taken to secure the doing of impartial justice, as upon this the real value of all such distinctions must be dependent. Every quality for which these awards are to be made should be of a lofty character, and be decided upon by judges professionally familiar with its best characteristics. The prize productions should, of course, in every case be publicly exhibited. Those who are inclined to dispute the policy or tangible good effected by these rewards, are recommended to read Mr. Aiken's address, delivered to the members of the Society of Arts, on the 12th of May, 1829, at the close of which is given a long list of the eminent artists who had competed for and won the medals which, great and celebrated as they became, they were always proud of possessing. Such of the societies

* Or, better still, if practicable, to adopt the plan of the Glasgow society, and announce at the commencement of the session the papers to be read on each of its forthcoming meetings.

† If the committee had a fortnight's warning of a paper not being forthcoming, they could fall back upon their own resources, which might be withheld for such occasions, or, at least, take steps of some kind to bridge over the difficulty.

‡ The first expense incurred in producing a medal is, of course, considerable, and the practice could, therefore, scarcely fall within the reach of our less prosperous, although, by no means, least useful, societies.

as distribute photographs of great merit amongst their members might associate, with the choice of their presentation prints, the competing for medals to be awarded to the producers whose pictures were chosen.

The first thing necessary for the encouragement and advancement of art in all its branches is, that a love and appreciation of it should be created in the public mind. To this end, long experience seems to show that there is no medium better than public exhibitions.

David Hume tells us that a state can scarcely carry its trade and industry very far, where all the surrounding states are buried in ignorance thereof, and this fact has its application to every branch of commerce of every kind. It is public patronage which develops and encourages every branch of art. Public patronage is only another name for public appreciation, and public appreciation cannot exist without the means of appreciating, or, in other words, of educating the public taste, for which purpose, it is well understood, no medium surpasses in importance that of exhibitions. This has been generally recognised in photographic societies, and every lover of the art-science—photography—should, therefore, eagerly and cheerfully co-operate to make these exhibitions thoroughly successful. The amateur or simple lover of the art, should strive to produce his best picture for this end. The professional should send his most artistic, attractive, and interesting specimens, and as these exhibitions have their origin in our photographic societies, photographers should consider aiding in the support and permanent establishment of such societies as a positive duty.

In proportion to the importance of our exhibitions should be the care and thoughtfulness expended in their management. Their managers should remember, as a recent writer in the *Times* said—"That motives of self interest sway the bulk of mankind, and that it is necessary to take these into calculation if you wish to influence the action of numbers." They should aim to bring together not only such specimens of the art's best productions, as photographers and artists will appreciate, but such as may also legitimately attract and please the general public. The exhibition of a monotonous collection of uninteresting subjects, although they may yet serve to illustrate to the full all the beauties and perfections of photographic operations, and win high praise from those who themselves practise and understand photography, will neither do much to advance the art in public estimation, nor encourage the exhibitors by increasing the number of their patrons. Not that I would advocate the sacrificing of excellence of production for attractiveness of subject, be it remembered. This would be too great a price even for success. Of course, every encouragement should be held out to attract exhibitors, because the larger their number the more various and numerous the specimens from which to select for exposition, and, judicious selection being pre-supposed, the greater the resulting attractiveness of the exhibitions. When exhibitions are successful, the societies to which they belong should gratefully remember that such success is due to the labours and talents of the exhibitors, and when they are not altogether successful they should still regard any pecuniary loss which might follow as money legitimately expended.* I should not consider it sound policy to ask exhibitors who are not members to contribute in making up a possible loss of this kind by paying for exhibiting space, however small the charges made might be. The speculation, not being that of the exhibitors, but that of the society, which, as it alone must reap the benefit of any probable success, should also be prepared to pay the cost of any probable failure, if the word failure may be strictly applicable in reference to a speculation intended rather for the encouragement and advancement of an art than the acquirement of idle revenue.

The commercial aspects of photography are so intimately associated with its improvement and prosperity, that societies

would do well not to overlook this subject. Writers on the laws of supply and demand in trade, all tell us that while scarcity generates competition amongst the buyers, and so keeps prices up, a supply exceeding the demand, sets the sellers anxiously competing, and so brings prices down. Now it seems to me, that in the most popular branch of photographic art—portraiture—we find this very aptly illustrated. Therein "cheapness is the order of the day." In the advertisement columns of the daily papers, almost every week shows us an increasing number of those photographers who are bent upon under-selling their rivals. The carte portraits, the "postage stamp" portraits, and the fifty reproduced portraits for half-a-crown, readily suggest themselves.* Establishments commanding higher prices, in vain stood out against the rage for cheapness, and one by one they have lowered their flag of high prices. Clever operators receiving high salaries, were engaged for the production of low priced pictures; and, although the rapidity with which they were compelled to do their work, "to make it pay," did not enable them to do full justice to their abilities, they certainly turned out photographs fully equal to those produced by many of the "higher priced" establishments. But the sign of cheapness is not a wholesome sign in the arts, whatever it may be in other branches of commerce. The practice of photography up to a certain point of common place merit is not difficult, the expense of apparatus, even when first class, is not great, especially when intended for the production of the small cheap photographs, and recruits are flocking into the ranks of the profession daily. Where, then, is this race of cheapness to end?

Under these circumstances, I would suggest to societies another view of this matter.

In the "fine arts," we have a certain class of productions which are so common as to sell for the most ludicrous prices. Their producers work in a state of shabbiness and semi-starvation in poverty-stricken garrets. You may picture one of these "artists" for yourselves, if you please. He is popping about, in his sky-parlour studio, from one to another of a row of canvases. With four sweeps of a brush filled with blue paint, four azure skies are completed; with the same number of dark violet streaks, four bits of distant country are created; four streaks of pale blue make four silvery rivers; and four sets, of a dozen dabs each, manufacture four green foregrounds. Four windmills are as expeditiously originated, and four picturesque cottages occupy no more time. Two or three narrow streaks of brown in each picture are then crowned with four dabs, made with a piece of sponge dipped in green paint—and lo! there are four "beautiful oil paintings," ready for the Dutch-metal "gold" frames of the cheap auctioneer or the travelling pedlar. This is what cheapness does for art, and if all our oil paintings were of no higher merit, painting would be contemptible, and these men would be our only great artists. Those acquainted with the history of art may indeed remember a time when art in this country was very little above such a level of degradation, and men of real talent were wearing out their pitifully wasted lives in the painting of tradesmen's signs and attractive pictures for the outsides of travelling fair-booths.

From the possibility of any similar state of degradation and misery, our photographic societies should anxiously guard the art they represent. There is one way of doing this, and that is by cultivating the higher aspirations of our ambitious artist-photographers, and forcing upon the public the recognition of their superior merits. Let them give more of their attention to photography as a fine art; let them cultivate not only the mechanical, but the æsthetic elements of the poetical and picturesque; and superior productions, associated with the effect of that publicity which is afforded by well organized and carefully managed exhibitions, must speedily raise the standard of excellence

* Providing always that such losses do not endanger the existence of the society.

* A friend yesterday informed me of an establishment in the city, now advertising "one hundred autograph portraits for five shillings."

into a region in which its refined and educated practitioners will be necessarily few, and its productions, as necessarily not cheap.

I have much more to say, and many more hints to give, but my paper is already too long, and lest so interminable a sermon should exhaust your patience, or I should find my hearers one by one dropping off into a comfortable nap, I will conclude. My remarks may not be looked upon with a favourable eye in every quarter, but I make them in all honesty and earnestness, being desirous only that photographic societies should see their own importance, and take such steps as may be permanently beneficial to the art and its professors, as well as to their own stability and honourable position. As Sir John Herschel says of science generally, so should it be said of photography as combined art and science, viz., that, "it delights to lay itself open to inquiry, and is not satisfied with its conclusions until it can make them broad and beaten, its whole aim being to strip away all technical mystery, and to illuminate every dark recess with a view to improve them on rational principles."

RAPID TANNIN PLATES WITH ALKALINE DEVELOPMENT.

BY THOMAS SUTTON.

MR. SUTTON has recently been trying tannin plates prepared with bromo-iodized collodion, and developed with an alkali in combination with a solution of pyrogallie acid without silver, as first proposed in the *Photographic News*. He has met with great success, which he describes in his *Notes*, from which we extract the following:—

"The alkaline development of dry plates has proved in our hands an extraordinary success, and by means of it we have rendered more than one of the slow dry processes as rapid as good wet collodion. This is certainly a very important result, and we hasten to lay the particulars of our experiments before our readers, for assuredly nothing of equal interest has occurred in photography for some time. The use of an alkaline developer for dry plates seems to us nearly certain to revolutionize the whole practice of out-of-door photography, whether for slow or instantaneous work, nor is it at all improbable that it may affect considerably the in-door operations of the photographic portraitist. There are so many advantages in a rapid dry plate, that when a good and certain process of preparing and developing such plates is generally understood, they cannot fail to be largely used in preference to wet plates.

"The mode in which we have employed an alkaline developer with so much success is simply as follows:—

"Make a saturated solution of bicarbonate of soda in cold water, and filter it. Make also an alcoholic solution of pyrogallie acid of the strength of 10 grains to the ounce of alcohol, and filter it also. Then develop in the following manner the dry plate, which has received only the same exposure as you would give to a good wet collodion plate:—First wet it all over with distilled or clean rain water. Then mix in a measure 1 drachm of the solution of soda and 1 ounce of water, and pour this all over the plate. The probability is that it will produce no visible effect, but that will depend upon the antecedents of the plate, and the mode of its preparation. When the film has been well wetted with the soda solution, return it to the measure, add to it a few drops of the alcoholic solution of pyrogallie acid, and pour the mixture again over the film. A marvellous effect is now produced, for the dark parts of the picture immediately start out and become distinctly visible, although they do not acquire much intensity. Let this alkaline solution remain a minute or so upon the plate until it has developed all the details of the picture, then wash it off, and intensify the faint negative in the following manner:—First, pour over the film the usual pyrogallie acid developer, containing acetic acid, but no silver. This does not act as an intensi-

fier, but it neutralizes the alkali of the film, and prevents fog in the next operation. Now pour this back into the measure, add to it a few drops of a 20-grain solution of nitrate of silver, and pour it again over the film. You will now see the thin red negative which has been obtained by the action of the alkaline developer become gradually more intense, and the details of the deepest shadows appear and acquire force and printing vigour. Follow up the operation to the proper stage, then complete it by washing off the intensifying solution, and fix the negative in the usual way. Your dry plate, which, with the ordinary development, would have required ten times the exposure, has now yielded a dense printing negative, clear as crystal in the lights, red in the blacks, and loaded with details in the shadows,—in a word, equal in all respects to a good wet collodion negative which has received the same exposure under the same circumstances. This is surely a marvellous result.

"But it is not *any* dry plate prepared in *any* manner which will work with the same rapidity as a wet collodion plate. The alkaline developer will not succeed with every kind of dry plate, and we must now state the conditions of collodion, bath, and preservative, which have given us the rapid results described.

"The collodion must be bromo-iodized, and made with pure ether and alcohol, without any trace of methyl or bad ether, and scarcely a tinge of free iodine. A red collodion which liberates nitric acid in the bath, will not do; neither will a collodion simply iodized, however good for the wet process. There must be a good strong dose of bromide in the collodion, and the proportion seems to be that in which the collodion contains an equal number of atoms of iodine and bromine. The film should be tolerably creamy, but not so much from the presence of a large dose of iodide and bromide in the collodion, as from a sufficient quantity of pyroxyline. An over-iodized film is very objectionable, and ought to be avoided. The collodion should also contain the right quantity of water, for if made with absolute ether and alcohol, the solutions never flow properly upon the film; and if it contain too much water, the negative shows crapy lines and cracks when dry.

"The strength of the bath should be at least 30 grains to the ounce of water, and it should be made with pure recrystallized nitrate of silver. It may be perfectly neutral; or if acid, it should contain acetic and not nitric acid, the latter acid being a powerful retarding agent. The time of immersion in the bath should be at this season about three minutes. It should not contain any acetate of silver.

"With respect to the preservative, that with which we have succeeded best is tannin 15 grains to the ounce, and it does not seem to matter greatly whether the tannin is left to dry upon the plate, or is washed off immediately after its application. When tannin is used the edges of the film should be protected by varnish.

"Another preservative which seems to answer very well, and give highly sensitive plates, is a mixture of albumen, honey, and carbonate of soda; but we have not yet arrived at the best proportions.

"Gun arabic does not seem to answer well with the alkaline developer. It answers best with the common mode of development.

"On the whole we prefer tannin, or tannin and honey. With plates prepared in this way, and an alkaline developer, we have taken breaking waves in the fraction of a second, and portraits in two seconds out of doors, and ten seconds in the shade, the exposure being in all cases the same as for good wet collodion.

"Towards the end of July last we received from Dr. Hill Norris a packet of his rapid dry plates, for comparative trial with our own. About five weeks after the receipt of them, we exposed the first of these plates in company with a photographic friend (Mr. Matthew Whiting, of Clapham), and also one of our own tannin plates, in the same camera, at the same subject, all the conditions of light,

lens, stop, &c., being the same for both plates. We gave to both the same exposure, viz., that which a good wet collodion plate would have required under the circumstances. The negatives were developed immediately, and with the following results:—

“Dr. Norris's plate, developed in the usual way with acid pyro and silver, gave a fully exposed negative of sparkling vigorous character, clear as crystal in the lights, and dense in the blacks. It was very easily intensified and very quickly developed; and the hypo removed the iodide of silver very easily and rapidly from the film. Nothing could be better than the behaviour of this plate. The film, though not protected by varnished edges, never cracked, or blistered, or played any disagreeable tricks. Moreover, the character of the negative was exactly such as every printer likes,—that is to say, the transparent parts when laid against black velvet looked as rich as the blacks of a good glass positive, whilst the high lights and half-tones had the beautiful creamy bloom of a good collodion negative taken with a pure bath and iodized collodion. All this was highly satisfactory, and the only observable faults in the negative on closer inspection were found to be some minute round white spots having a black speck in the centre.

“The tannin plate, treated with the alkaline developer described in this article, came out equally well, and yielded as fully exposed a negative as the other, and one which would print as well, although perhaps not quite so quickly. If anything, this was the better exposed negative of the two. It is free from the white spots observable in Dr. Norris's plate; but the film required an edging of varnish, and the high lights are not so beautifully clear and transparent as in the other negative when laid against black velvet; neither is there the same beautiful surface bloom on the high lights. Both, however, are admirable negatives, and Mr. Whiting has taken them with him to show his friends, and then forwarded them to Dr. Norris. The tannin plate had been kept a week before exposure, and Dr. Norris's more than a month.

“From the two last experiments which we have made with tannin and honey instead of tannin alone, it appears that a still higher degree of sensitiveness may be thus obtained. Our present belief is, that ere long a dry process will be discovered which will go far beyond the wet in sensitiveness, unless an alkaline developer can be successfully applied in developing a wet collodion plate.”

Correspondence.

FOREIGN SCIENCE.

[FROM OUR SPECIAL CORRESPONDENT.]

Paris, October 7th, 1863.

At a recent meeting of our society M. Davanne communicated the following observations on the glass employed in photography:—

“I call the attention of the Society to a question which seems to me to possess very great interest for photographers, especially for those who, having a large business, make a large consumption of glass plates.

“In France plate glass costs so dear that we often prefer to employ blown glass, while our colleagues in England and Germany obtain glass perfectly adapted for all the purposes of photography at a very low price.

“We ought, I think, to inquire into the cause of such an anomaly. French plates are of finer quality, perhaps, although generally a little green; and they are also, I consider, stronger and better polished, but the German plates, with their delicate blue hue, seem to me quite as good, and possess the advantage of costing much less.

“These German plates are frequently finished only on one side, the other remaining rough, or nearly so. This may be an advantage for photography, for the unpolished side, by diffusing the light, may produce more softness.”

M. Davanne presented, in the name of M. Levitzky, and

on his own part also, the following observations on the employment of the sulphocyanides for fixing negatives:—

“Some months ago, a committee, of which we had the honour of being appointed a member, examined the new fixing agents proposed by M. Meynier, and recognized that, theoretically, these salts can replace hyposulphite of soda and cyanide of potassium in the fixing of negatives and positives. But practice must sanction the theory, and the difficulty of procuring these new salts, and their high price, render experiment nearly impossible. Happily, the confidence we entertained of seeing the price soon reduced, is happily confirmed, thanks to the skill of our chemical manufacturers, and the price of 60 francs the kilogramme, first proposed, soon fell to 30, then to 18, and to 9 francs, and now it is 7, and 6 francs, and even less. The sulphocyanide of ammonium is not the only one that can be employed. The sulphocyanide of potassium exhibits exactly the same properties, and each may be employed indifferently.

“We do not know if the application of the alkaline sulphocyanide to the fixing of positives has been made on a large scale; their high price has doubtless checked more than one experimenter. But this inconvenience, although much less than in fixing negatives, has permitted of its employment in a cursory manner, and one of our colleagues, M. Levitzky, has been struck with the advantages these fixing agents present over the cyanide of potassium and hyposulphite of soda.

“He states that the action of the sulphocyanide of ammonium is slower than that of cyanide of potassium in the operation of fixing, and that if we wish to make the fixing prompt, we must employ a saturated solution, or one at least of 75 to 80 per cent., but we can perform this operation in a dish, and employ a solution of less strength, which, nevertheless, must never be less than 50 per cent.

“This fixing agent gives results very superior to those obtained with cyanide. The negative is sharper, and it is remarkable that the lights retain their transparency and exhibit much more detail; while the action of the cyanide always renders the whites more or less opaque. M. Levitzky notices an inconvenience that has occurred to him; this is, in keeping the solution of the salt in the operating room, an ammoniacal odour is developed sufficient to fog collodion plates in the vicinity of the dish of sulphocyanide. This inconvenience would be avoided by using sulphocyanide of potassium.

“For our own part, we are engaged from another point of view, presenting great advantages for travelling photographers.

“For a long time we have abstained from fixing negatives on albumenized collodion obtained on our excursions, before returning to our laboratory. Cyanide of potassium presents the inconvenience of completely detaching the film from the glass plate, and in the Taupenot process we can employ only hyposulphite of soda. But carrying this salt in the box where the other apparatus is packed incurs great risk of spotting in the course of the manipulations from the jars or shocks of carriage, and we have given it up. In such cases, the alkaline sulphocyanides may be employed without risk; they leave the albumen film intact, and fix the proofs rapidly, and we think they will soon be employed by all travelling photographers, whatever process they adopt. Let us hope that the more general use of these salts will cause a still further reduction in their price.”

FORMIC ACID IN THE DEVELOPER.

SIR,—Colonel Stuart Wortley is so skilful a photographer that he could produce a good picture with materials which would be worthless in the hands of others. He knows not the danger which attends the employment of an iron developer, where large plates are used; and by less skilful photographers than himself, its stains, its difficulties of intensification, and the chances after its numerous intensifica-

tions and washings, that before the plate can be varnished its film will have split, or fallen off in rags. He, therefore, does not appreciate the value of a developer, which can be employed with a bromo-iodized collodion, instead of iron, and has treated the Sergeant rather roughly; but, I am sure, that there are many who will agree with me in thinking that our thanks are due to Sergeant Moss for his communication, and that, although he was not the first to recommend the use of pyro and formic acid, he has the merit of having been the first to give a simple formula, which may, in many cases, supersede the use of iron where a bromo-iodized collodion has been employed. I have tried his developer with three plates 10×8 . The day was dull and sunless, raining frequently, and with much wind. I used Ponting's bromo-iodized collodion in each case, and without stain or intensification I obtained a fair negative. The detail of foliage may not have been as delicate as it would have been with iron, but it was sufficiently good; so that, if there had been no confusion of the leaves from wind, I could have distinguished the ivy with which a wall is covered from the other creepers which grew on it, and I am quite sure that there is much less risk of the splitting of the film. Of the three negatives, one showed *no inclination* to split, the other two would, probably, have remained firm had I not brought them to a fire when only half dry. They were partially injured, but so slightly that had I been using iron I should have considered my afternoon's work a "bonne fortune."

I certainly gave a much longer exposure than that given by the Sergeant (perhaps owing to the dulness of the day), and my developer had rather more pyrogallie than he recommends; but this deviation from his formula may not have been an improvement.—I am, Sir, your obedient servant,

September 30th, 1863.

ANON.

MICROSCOPICAL PHOTOGRAPHY.

SIR,—In the last number of the PHOTOGRAPHIC NEWS, at page 478, there is a communication in which two claimants are named as inventors of a so-called microscopic camera; and as my name is introduced, I beg you will permit me to make a few remarks. I was certainly surprised to find that a patent should have been obtained for an arrangement, which, in its essential parts, must be familiar to all who have engaged for years past in the enlargement (by photography) of microscopic objects; and also to those who have been employed in the process of reduction. In the year 1840 I made use of a similar apparatus (to the one recently patented) for producing pictures of magnified objects on daguerreotype plates, both by daylight and artificial illumination; and in the same year I exhibited this process publicly at the Mechanics' Institution, in Liverpool. During a lecture a flea was photographed to 6 inches in length. On this occasion I used oxy-hydrogen light for illumination. By the reverse process (reduction) I produced miniature views and printed matter for examination under the microscope: these were, however, limited, as I found the mercurial deposit too coarse for any magnifying power above 20 times linear. The discovery of the collodion process by Mr. Archer enabled me to continue my experiments, both in the enlargement of microscopic objects and also in the reduction of objects to be viewed under the microscope. The deposit which forms the picture in the collodion process being very much finer than in the daguerreotype, photographs can now be taken containing more than one-hundred portraits in a surface one-hundredth of an inch square. I claim to have originated photographs for examination by the microscope, but do not imagine any merit due to me for the arrangement of the apparatus for microscopic photography; as this would naturally suggest itself to any person engaged in such experiments, and which I have used and supplied to others for so many years past.—Yours truly,

J. B. DANCER.

Manchester, 43, Cross Street, October 6th, 1863.

Photographic Notes and Queries.

DURABILITY OF GUTTA-PERCHA TRANSFERS.

SIR,—It may interest Mr. Russell, to whom we are all so much indebted, to know that the gutta-percha transfers to which I referred were made some years since, and that they are not in the least brittle. I saw them, shortly since, roughly shaken, to show their electrical condition, adhering to the palm of the hand turned to the floor, and they exhibit no brittleness whatever. I have no time, myself, yet to make experiments in this direction. I find, however, that by pouring chloroform on fine gutta-percha chips, sufficient to cover them, and, after they are soft, putting them into benzine or benzole, a good solution is obtained; and after the deposit of colouring matter takes place, I have a tolerably clear solution of gutta-percha.

C. C.

THE DISCOVERY OF ALKALINE DEVELOPMENT.

DEAR SIR,—That great unknown, "Delta," who pitches into me in a letter quoted in your last leading article—tell him, please, and your readers also, that I do not claim to be the discoverer of the alkaline development, and never dreamt of doing so; neither do I know who is the discoverer. Tell him, also, that I do not like people to say nasty things of others under a feigned name; and I consider any man who does it a sneak.

You will greatly oblige me by inserting these few lines in your next.—Yours faithfully,

THOMAS SUTTON.

Jersey, October 5, 1863.

THE EARTHQUAKE.

DEAR SIR,—Being on a tour with a friend, we were somewhat startled on the morning of the 6th inst., at 3.30 A.M. by a severe shock of an earthquake; it lasted about 5 minutes.

The air previously was very hot and close; then came a low rumbling noise in the direction of south to north, increasing in intensity, and then gradually dying away. This lasted for three minutes. To this succeeded a violent rocking and shaking motion, the bed being rocked to and fro, one of the children in an adjoining house being nearly tossed out of its crib. It may be expressed thus:—Two shocks, one much shorter than the other; after this an intense cold succeeded. I should be glad to hear if the same was experienced elsewhere, in other parts of England.—I am, Dear Sir, yours truly,

W. H. WARNER.

Madley, near Hereford, 6th October, 1863.

Talk in the Studio.

PHOTOGRAPHY FOR ILLUSTRATION.—We understand that Mr. A. W. Bennett will publish, early in the approaching season, a second volume of "Howitt's Ruined Abbeys and Castles of Great Britain and Ireland," illustrated with photographs, one of its chief features being Kenilworth Castle, and a volume of Widdoworth's poetical descriptions of the scenery of the English Lake Country, also illustrated by photographs of the scenery described, a companion volume to the "Lady of the Lake" of last year.

A PHOTOGRAPHER AND AERONAUT.—M. Nadar's monster balloon has not yet "aspired the sky," but is to do so. Your readers, I believe, know that the design of M. Nadar is to render aerial voyaging not only instructive, but pleasant; so he has constructed reading and billiard rooms, and a photographic studio, in addition to the usual living apartments. The car which contains these is two-storied, the upper floor being a terrace, surrounded by a strong railing, or *garde-fous* (*absit omen!*), from which, I presume, our travellers are to fish for birds, for M. Nadar is amply supplied with fishing tackle, which must either be intended for aerial sport, else as provision against their "falling in the sea." [Since the above appeared in the *Daily Telegraph*, M. Nadar, and about a dozen friends, made an ascent, intending to remain in mid-air for four days, but some accident to the tackle compelled an earlier return to *terra firma*.]

PHOTOGRAPHY AT THE EISTEDDOD.—A paragraph has been going the round of the press, regarding a photograph of Brinley Richards' lost umbrella, at the Eisteddod. The true particulars of it are as follows. The above-named gentleman being present at the national gathering of Welsh bards, at the

Swansea Eisteddvod, and of which institution he is an honoured and respected member, he happened to lose his umbrella twice in an audience of 7,000 individuals. Mr. W. Griffiths, an assistant to Mr. Hughes, having taken down with him a case of photographs (which is now on exhibition at Mr. Leblanc's, 57, High Holborn) for exhibition, the photographs attracted some attention, and the peculiarity of the umbrella, and the truthfulness of the photograph was such, that the umbrella was twice recovered and restored to the owner through its aid. Mr. Griffiths, writing to us on the subject, says:—"The fact being known that I am salesman to Mr. Jabez Hughes, of Oxford Street, it was inferred that Mr. Hughes was the photographer. Mr. Hughes, however, has nothing to do with the series which I am now publishing—indeed, he has not yet seen them; so that it is an error for the press to attribute them to him, although I should not be sorry for them to be connected with him, as I think they would do even his reputation credit: but it is a pity for an error to be circulated. You will see by this circular the particulars of the series to which Brinley Richards' portrait belongs. I have much pleasure in enclosing you a copy of his portrait, also one of J. C. Hughes, Esq., of Manchester, the 'Wordsworth' of Wales, and author of the original *Welsh* words of 'God Bless the Prince of Wales,' and of which the English version is a translation. To the original *Welsh* words, Mr. Richards first composed his now world-wide national air." The photographs form a very interesting series, and will be valued by all concerned in the bardic festival of the principality.

CORNWALL POLYTECHNIC SOCIETY PRIZES.—H. P. Robinson Esq., Leamington; "Stoneleigh Deer Park;" the silver medal of the first class, offered by the Society for the best photograph in the Exhibition. The Chairman of the judges of this department said "that they could not hesitate in awarding Mr. Robinson this prize." Col. Stuart Wortley, silver medal of the first class, for his studies of sea and clouds, as the best amateur collection. S. Thompson, Esq., Notting Hill, London, bronze medal of the first class. S. H. Morgan, Esq., Clifton, bronze medal of the first class, for his studies of trees, &c. J. N. Tressidder, Esq., Surgeon, H.M.I.A., £1, third best amateur collection.—A. C. STEPHENS, Manager of the Art Union of Cornwall.

ROYAL PORTRAITS.—The new King of Greece, and the Prince and Princess of Wales, honoured the fine studio of Messrs. Southwell Brothers, with a visit, a few days ago, and sat for portraits, which were very successful.

MULTIPLICATION AND ENLARGEMENT OF NEGATIVES.—Whilst in Newcastle, we visited the studio of Messrs. Downey, Brothers, where we saw some examples of remarkably successful reduplication and enlargement of negatives. The demand for their interesting series of card and other portraits of statesmen and other public men, obtained in London this summer, being very large, they have felt it desirable to facilitate printing by multiplying negatives. This they effect in the usual manner by producing first a transparency and then another negative, and in many instances this is effected with such skill that it is difficult to distinguish the copies from the originals. An enlargement of the head of Lord Palmerston is one of the most successful examples by this method which we have ever seen, and is round, delicate, soft, and well-defined. There is no speciality in the mode of working beyond the exercise of care and judgment.

To Correspondents.

PERCENTATOR.—The ready decomposition produced by the reaction of the iron developer and the free nitrate solution, on a plate, may be due to various causes. A neutral bath and too little acid in the developer may cause it; the presence of organic matter in the nitrate bath will frequently cause it; both or either of these conditions are likely to cause it in hot weather. 2. A "concentrated solution" is not a very definite term, but, when used, is generally meant to describe a solution stronger than is usually employed. For instance, in chloride of gold, a solution containing one grain to an ounce would be called concentrated; whilst, in nitrate of silver, a solution containing one hundred grains to an ounce of water would be regarded as concentrated. 3. Sulphide of silver, which is the precipitate produced by adding liver of sulphur to solutions containing silver, must be reduced in the crucible, it cannot be properly converted into nitrate of silver, without first being reduced as metallic silver. 4. If the bath for exciting negatives be too weak, the image will be feeble, and formed only on the surface instead of in the film.

N.—In our own experience, nearly equal rapidity may be gained by the use of pyrogallic and formic acid, and by the ordinary iron developer; but we prefer the negative produced by the latter, as more delicate and perfectly

detailed, giving a more perfect register of every gradation in the subject. 2. Careful drying is of the utmost importance when a film is disposed to crack; but, unless it be so disposed, the precautions you describe are not necessary. The fact, that the varied remedies to which you refer are recommended, may either imply that various causes will produce the same result, or that much uncertainty or ignorance prevails as to the real cause. We know that, with some collodions, the tendency exists, and that others are quite free from it; and, whilst the consistency of the collodion, and the proportion of solvents, may in some degree modify the tendency, its primary cause is, we believe, in the character of the gun-cotton. Nevertheless, whenever the tendency exists, careful drying is one efficient mode of preventing mischief. 3. We do not regard the strongly expressed opinion to which you refer as of much weight, and we fear it is sincerely impartially given. The mass of evidence which reaches us from the best authorities, is in the opposite direction, very decidedly, those of the maker not recommended possess all the good qualities of the other with greater depth of definition besides. 4. The letter was in type. Thank you for your attention in the matter of the back numbers.

W. W. WILSON.—The only large views of Swiss scenery, which we know, are those of Bisson, Freres; we do not know whether they have any agents in this country.

A. H. WARDLOW.—We will propose you, and you can attend the future meetings.

SUBSCRIBER G.—We prefer those of the London maker, decidedly.

T. P.—Lime water is common water saturated with hydrate of lime. The colder the water, the greater the proportion of lime it will dissolve. If exposed to the atmosphere, it quickly becomes covered with a pellicle or film of carbonate of lime, from the action of carbonic acid in the atmosphere. It is strongly alkaline. 2. Common soda is the term used for the carbonate of soda used by the laundress. 3. The addition of chloride of iron to sulphate of iron would only be injurious in the developer, as the chloride would precipitate the free nitrate of silver on the plate as a chloride. 4. Waved marks in the background may proceed from many causes, but very frequently arises from the use of a thick cadmium collodion. 5. Hyposulphite of soda may be kept in solution without injury, if it have not been used. 6. We do not quite understand your question, "What chemical suffers most suddenly visible alteration in diffused light?" Chloride of silver darkens most rapidly. 7. Cyanide of potassium is a very energetic solvent of the salts of silver, but it is not suitable as a fixing solvent for chloride of silver in positive prints.

JONAH.—1. Yes. 2. Probably. 3. We have not tried it; but probably, yes. 4. We do not know any better at the price.

FRANCIS VINCENT.—A strong bath, unless freely acid, is much more prone to give streaks than a weak one. You may probably get rid of the streaks by adding nitric acid freely, which with fully bromized collodion may be done without loss of sensitiveness; or by neutralizing the bath with carbonate of soda and sunning the solution for a day or two.

OLD SUBSCRIBER.—You may neutralize and sun a printing-bath if you choose; but we should not think it necessary. 2. It is not essential to have a printing-bath acid at all if it be strong enough; but if it be at all weak it is better to have a slight trace of nitric acid present to prevent the albumen being dissolved. A new bath of 60 grains of nitrate of silver to an ounce of water will generally give good results without any addition.

HENRY.—We see no especial advantage to be gained by dispensing with a sliding body; but if you wish it, the plan you propose of having several grooves to admit slides at distances from the lens varying from 33 inches to 15 inches may be used. The chief difficulty to be guarded against in such case is the risk of admitting light through some of the many openings. 2. We have not made comparative trials of the two collodions you name, but have found both good. The one by which your print was taken we have fancied the cleanest, the other the most sensitive. The print appears to be very good.

L. M. II G.—It is difficult to state with certainty the cause of the spots without knowing more about the circumstances. They very much resemble the result produced by placing any unvarnished negative, which has been intensified with mercury, in contact with the sensitive paper.

A POOR AMATEUR.—It does not necessarily follow that a manufacturer who guarantees his goods "inferior to none," whilst they really are inferior, is a cheat. He may fancy them inferior to none, and his judgment may be at fault. A man's opinion of his own productions is rarely quite impartial. In the case you quote, as in most cases, it is probable that the lowest price is worst. We should not, for ourselves, select either; but we cannot in this column undertake the invidious task of recommending any by name.

J. N.—Use good water colours without any addition, but clean water. If the colours work greasily add a little prepared ox gall. Newmans make a "preparation" which may be used with advantage prior to applying water colours to albumenized paper. A little gum water may be applied to the shadows. Wall's work on colouring, or Newman's "Harmolous Colouring," applied to photographs, will be useful to you.

IAON AND AMMONIA.—The double salt of iron and ammonia may be used very similarly to ordinary protosulphate of iron. A solution containing 50 grains of the double salt, and 29 minims of glacial acetic acid to the ounce of water, gives excellent results.

Several Correspondents in our next.

Photographs Registered during the Past Week.

- MESSRS. W. R. SHORE AND CO., 11, Western Road, Brighton,
Three Photographs of William Digby Seymour, Q.C., M.P.
- MR. JOHN FREW, 7, Railway Terrace, North Shields,
Photograph of Dr. John Burns,
Photograph of the late Robert Towerly.
- MR. THOMAS LOW, Meadowsdale, Dundee,
Photograph of Sir David Baxter.
- MR. A. S. WATSON, 2, Regent Road, Great Yarmouth, Norfolk,
Photograph of Edward Bellases, Esq.,
Photograph of Rev. — Hurst.
- MR. W. H. BARTON, 26, Triangle, Clifton,
Four Photographs of Rev. Canon Neve.

THE PHOTOGRAPHIC NEWS.

Vol. VII. No. 267. — October 16, 1863.

CONTENTS.

	PAGE		PAGE
Art in Photography	493	Oxide of Silver Prints. By F. F. Thompson	500
Mr. Robinson's New Picture	493	A New Method of Ascertaining the Angle of Aperture of a Lens	500
Photographic Chemicals	495	Proceedings of Societies—South London Photographic Society	501
On Photography in Connection with Art. By the Hon. Lieut. Col. Stuart Wortley	496	Correspondence — Transferred Albumen Films — Microscopic Camera	502
Jottings from the Note-Book of a "Photographer's Assistant" No. III.	498	Photographic Notes and Queries—Gold Toning—Roughing the Edges of Glass	503
Photolithography.—No. IV. By Joseph Lewis	499	Talk in the Studio	504
Lactate of Silver for the Bath, &c. By M. Mc. A. Gaudin	499	To Correspondents	504
Iodide of Silver in Collodion. By M. Mc. A. Gaudin	500	Photographs Registered during the past Week	504

ART IN PHOTOGRAPHY.

THE questions "What is art?" "What are the qualities called 'artistic'?" "What is 'artistic feeling'?" have often been asked, and very much has been said and written for the purpose of defining and limiting art and art qualities. Very often what has been said and written has simply "darkened counsel by the multitude of words without wisdom." It is difficult to deal with the subject in a mere definition, as the appreciation of art is as much a matter of feeling as of knowledge. As an aid to comprehending the subject, we cannot forbear calling attention to, and repeating, a passage in Colonel Stuart Wortley's admirable paper on "Photography in Connection with Art," which, by the courtesy of the writer and of the secretary to the Cornwall Polytechnic Society, we are enabled to give on another page. The Colonel observes:—

By a feeling for art, I mean that intense appreciation of the beauties of Nature that leads us not to be satisfied till we have, in our humble way, done our best by means of such arts and such contrivances in our power, whether drawing, painting, or photography, to reproduce faithfully what we most love and enjoy in Nature; and I maintain that the highest art, the purest taste, is shown in the most scrupulously faithful transcript from Nature itself, because nothing, and no imaginary form or colouring, can equal, or, I might indeed say, approach in beauty what, if we care to look for it, and know how to find it, can find for ourselves in Nature. And it is pre-eminently this earnest desire to seek for and discover the beauties of Nature, and the knowledge of how and where to find them, that distinguishes the artist from the mere painter or photographer.

This love for, and earnest appreciation of, what is beautiful in Nature, from the primeval forest in its solemn grandeur, to the tiniest leaflet or blade of grass that grows by the way-side; from the wild and untameable glories of the eternally changeful sea, to the simplest ripple of the little brooklet just leaping into life out of the mountain side: from the manifestation of the loftiest, the most stirring emotions which ever aroused nations or startled humanity, to the expression of the simplest feelings which illustrate the "short and simple annals of the poor"—this is artistic feeling. The rendering of this feeling, the embodiment with an adequate expression of the beauties of Nature, by whatever means or materials, is Art. Artistic feeling is generally a natural endowment, but it may be largely increased, if not entirely originated, by cultivation. But to give artistic feeling expression requires knowledge, and hence becomes important a study of the experiences of those who have left glorious legacies of beauty to mankind, and observation of the rules—which are not arbitrary—growing out of those experiences: rules which should guide, but not trammel. If these definitions of artistic feeling and of art be correct, on what possible plea can photography be denied the power to give them embodiment?

MR. ROBINSON'S NEW PICTURE.*

MR. ROBINSON has for some years past set himself a task, which he performs with religious care. Whilst attending, as every man must, to the every-day routine of his profession of portraiture, making pictures of his sitters where he can, and letting likenesses serve where pictorial results are impossible, he also resolved to produce, at least once every year, something for photography, something to show the capabilities, and, if possible, elevate the position, of the art he loves, and by which he lives. Whilst giving the "pot-boilers" every legitimate attention, each summer must yield something for the honour of the art and the artist. The production of large pictorial compositions, by printing from several negatives, is the speciality to which Mr. Robinson has devoted his higher attention, believing that if brain and fingers are sufficiently capable, photography presents appliances and facilities for producing pictures capable of satisfying all the requirements of true art, and of gratifying the art-tastes of all who are content with delications of Nature as she is, and do not crave for what Ruskin calls the "audacious liberty of that faculty of degrading God's works which man calls his 'imagination.'"

In Col. Stuart Wortley's admirable paper on Photography in Connection with Art, given on another page, he remarks that "composition photography, more than any other, shows how difficult it is to obtain really artistic results in photographs; and he further adds his conviction that these difficulties "will always prevent that class of photography from rising beyond a certain level." We can endorse these remarks; but it must be with a qualification. The first part of the sentence states a general truth, applicable to almost any subject. The higher branches of any art most strikingly show its difficulties; the nobler the results sought after, the more apparent will be the inadequacy of the means to attain them. But these difficulties overcome by ability and perseverance; this poverty of material and appliances surmounted by skill and rightly applied knowledge, the results are immeasurably superior to those produced by less skill and simpler agencies. That these difficulties will prevent composition photography from rising beyond a certain level, is, if taken literally, a simple truism; but if it imply that the level is a low or insignificant one, we think that the progress which has been already made in Mr. Robinson's hands alone, points to a very proud future for this branch of the art; and we are sanguine enough to believe that when the same amount of careful art-study and varied ability, which have been given to the older arts of painting, &c., shall be applied to photography, it will be found that neither are the materials intractable nor the results unworthy of the effort.

Without the facility of combination which has been designated "composition photography," the scope of our art must be greatly limited, either to the production of small pictures,

* AUTENS: Photographed from nature in several negatives, by H. P. Robinson, Leamington.

or, more often, to mere portions of pictures. Col. Stuart Wortley has well denounced the mere "photographing of foregrounds," and insisted on the importance of a sky to complete a landscape. The composition photographer goes farther; he insists on all the parts of a landscape, and on the presence of figures, not merely to aid the composition, but to give the picture human interest.

"All true landscape," Ruskin observes, "whether simple or exalted, depends primarily for its interest on connection with humanity," and the elements of this interest Mr. Robinson can best secure, he thinks, by the means he adopts. His latest work is entitled "Autumn," and it may be very properly designated a landscape with figures, in contradistinction to several of his former pictures, which have consisted of figures with landscape background. The titles indicate the difference in intention. Take two of the most important of former years; we have "A Holiday in the Woods," in which the children playing in the thickly wooded neighbourhood of Kenilworth, form the feature of interest. In "Bringing Home the May," the illustration of the rural pastime is the primary motive of the picture, the landscape is only accessory. But in the picture before us, the landscape claims an important part in the intention of the composition, and not less than the autumnal suggestion of the figures, with their sheaves of gleaned wheat, indicate the subject of the picture. The lines from Scott, which accompany the picture, with Mr. Robinson's happy facility of quotation, admirably describes the scene.

"—The distant reapers' mirth we hear,
The last blithe shout hath died upon our ear,
And harvest home hath hushed the clanging wain:
On the waste hill no forms of life appear,
Save where, sad laggards of the autumnal train,
Some youthful wanderers glean few ears of scattered grain."

The first glance at the picture charms us. We see a bold and well-composed foreground, with groups of rustic figures resting by an old stile, or reclining on a bank of brake and heather, which overhangs a river. Beyond, a landscape such as, in photography, rarely glads the eyes of man. Stately trees, which spread their long evening shadows far over the landscape, form a grove winding gracefully by the side of a sparkling rivulet, whose fantastic curves carry the eye into the dim distance. Over receding grove, and brook, and plain is spread a fairy robe of atmosphere; and it is atmosphere, with the mellow light of an autumn evening; not the misty, foggy, appearance which quickly closes up the view and then passes for an atmospheric effect. The eye here reaches for miles, and forms, whilst they diminish and grow dim, are still slightly made out, as seen through the translucent veil of atmosphere. The tone and feeling of the picture, and the sheaves of wheat at the feet of the gleaners, at once tell us it is autumn; but so wonderfully full of tone and gradation is the picture, so suggestive is its rendering of colour, that no stretch of fancy is required to clothe it with all the gorgeous hues, the varieties of golden brown and yellow, of green, of russet, and of crimson foreground, of blue and purple distance, which belong to declining summer, or harvest time. Such is the first impression; but let us describe it in sober detail.

The size of the picture is twenty-four inches by fifteen inches. In the foreground stands the principal group, two female figures, resting and watching with interest something or somebody approaching. The hand of one is raised to shade her eyes from the glinting sunlight, which just tips her face. A large sheaf of newly gathered wheat at the feet of one, and a smaller one under the arm of the other, bespeak their late employment. They lean against a grand gnarled and half decayed old tree trunk, which forms part of a stile, on the step of which rests a younger bonny little country lass, who grasps her gleaned sheaf on her lap, but turns her head to look in the same direction as the elder girls. To the left, sitting with his legs across the upper bar of the stile, is a lad, evidently a lazy dog: he leans back against another tree trunk which forms part of the stile, with an air of the supreme indifference, the very picture of *insouciance*,

or, as a somewhat slangy friend has just phrased it, "devil-may-careishness." His presence during the day has not, we feel sure, added to the size of the sheaves gleaned; hazel nuts, black-berries, crab apples, and similar reflections from the hedge-rows, have had more charms for him than following the reaper or wandering amongst the stooks to glean the scattered ears. Detached from the principal group to the right of the foreground, which is varied with tangled clumps of brackens and bramble, is another figure, with her gleanings, seated on the ground, looking over the landscape, her back only being seen. Stretching over the whole of the picture is a most charming landscape, well wooded, but still open. Commencing on the right of the picture, a little behind the foreground, just in advance of the middle distance, is a noble grove of trees, receding far away, and reaching the extreme distance, within a few inches of the other end of the picture. Meandering at the foot of the grove, with devious wayward course, is a lovely brook, or river, with exquisite sparkling lights among the deep shadows of the reflected trees. To the right of the picture, from the foreground to the extreme distance, is an immense stretch of level park land, just sufficiently broken with one fine tree in the middle distance.

The feeling of this, as of almost all Mr. Robinson's compositions, is essentially idyllic; but here, more than in any other, is the sense of rural quiet, and of the vast grand repose of Nature. A few minutes' quiet contemplation of the picture has a soothing, tranquillizing effect on the mind; we seem to mingle with the scene, and enter into its autumnal feeling of fullness, ripeness, rest. The time is evening, as we have already said. A gleam of parting sunshine lights up part of the group, and of the trees, and rivulet, whilst the rest is in diffused light or shadow.

But the wonderful charm of the picture, and its leading characteristic, is the perfect sensation of atmosphere. This essential quality of English landscape is here more perfectly illustrated than we have ever seen it effected by photography. The foreground and figures are very vigorous, beautifully rounded, and soft, but still brilliant and forcible. The huge trunks which bound the stile stand out bold and massive against the fine oak in the middle distance; and this is forcible, compared with the trees beyond, which recede with exquisite gradations into the most delicate and tender distance, which is again surmounted by light, delicate stratus clouds. The little rivulet, which, as it gracefully winds along, also takes the eye gradually into the distance, shows the atmospheric effect on its sparkling lights and mysterious-looking shadows. There is a lightness, a delicacy, an airiness about the whole picture, which is as novel and surprising as it is beautiful. Every one is familiar with a fact common to photographs, especially large ones, however perfect; the first glance at them, when hung on a wall at a little distance, gives a certain impression of heaviness. There is a want of light and transparency, which at first suggests that the picture is too dark, even though it be a light impression. In this picture there is an entire absence of that effect—the first glance satisfies us with the general effect, and a continued examination delights us with its truth and beauty.

As an artistic composition, this picture is very admirable, and is arranged with sufficient subtlety to conceal the art. The masses and lines are perfectly in keeping with rule, without any formality: the pyramidal form may be easily traced, but it is formed by the natural relation of the objects, so that it appears to be the result of accident, rather than design. The perpendicular trunk, which forms part of the stile, bounds the picture on the left, supporting the whole and giving solidity. The ferny bank in the right foreground, which conceals the nearest part of the brook, and the back of the reclining figure, stand out in bold and wonderful relief against the stretch of open ground and distance. The lovely little stream, apart from its own peculiar beauty, does its office so well that it reminds us of the little white dog in one of Gainsborough's pictures, in

reference to which, when asked by an old lady why it was there, the artist replied, "To carry the light through the picture." The expressions and attitudes of the figures are perfect, and in admirable keeping with its purpose. An art connoisseur, who examined the picture in our study a few days ago, exclaimed, "This is surely not a photograph; it is a painter's composition." The picture is, nevertheless, for the most part, a transcript of Nature exactly as it stands; and we have gazed with delight on the scene in Stoneleigh Park, which forms the important part of the landscape, so that to us it possesses the added charm of *vraisemblance*.

Photographically speaking, this is, moreover, the most perfect composition picture we have seen. The gradations are more perfect and delicate, without the least sacrifice of roundness and vigour, and it is to its excellent photographic qualities, as well as the skilled composition, that much of the atmospheric effect is due. We may here remark that in this respect the picture is a triumph of a process we have so long and steadily advocated—we mean the use of bromo-iodized collodion and iron development. This is the first composition picture Mr. Robinson has produced with these agents, a simply iodized collodion and pyrogallie acid development having been used before for all his large pictures. In this he has used Mr. Blanchard's bromo-iodized collodion; and the picture is the best yet produced, especially exemplifying all the qualities claimed for the process. It is from four negatives, and is more easily combined in printing than any former similar picture: and Mr. Robinson remarks, that whilst it more perfectly realizes the conception he had in his mind to begin with, it is produced by a less expenditure of photographic means than any former similar composition.

Mr. Robinson has also just produced two or three other charming large pictures. One is a clever *genre* study, entitled "Somebody Coming," consisting of two rustic figures at a stile, one of whom cries "somebody coming" as she archly glances at the approaching sweetheart of the other, who averts her head. The others are two very fine views of Warwick Castle. One, an often repeated subject, the view from the bridge, with the Castle embowered in foliage reflected in the river, an admirable illustration of the lines from Milton's *L'Allegro*, which accompany it:—

"Shallow brooks, and rivers wide,
Towers and battlements it sees,
Bosomed high in tufted trees."

It is, notwithstanding the repetition, the finest picture of the subject which has yet been produced. These will, doubtless, together with the large picture, be hung at the exhibitions of the forthcoming season.

PHOTOGRAPHIC CHEMICALS:

THEIR MANUFACTURE, ADULTERATION, AND ANALYSIS.

Zinc (*continued*).—The oxide of zinc previously mentioned as obtained by the ignition of the metal, is, of course, anhydrous. A hydrated oxide, which will be found very useful in the laboratory for many purposes, on account of the ease with which it dissolves in, and neutralises, small quantities of acids in solution, as well as for other purposes, may be prepared by adding to a moderately dilute aqueous solution of nitrate of zinc a solution of potash,—adding the latter gradually, and stopping before the whole of the oxide is precipitated. A light, flocculent precipitate will come down, which must be washed with hot water until no zinc is detected in the liquid which runs away. If an excess of potash is added to the solution of zinc, the precipitate will always contain potash, which no amount of washing will remove. The precipitate must be allowed to dry in the air, and preserved in stoppered bottles, to prevent its being contaminated with the acid vapours always present in the atmosphere.

In speaking of the advantages arising from the use of zinc white in painting, we mentioned that one great benefit

consisted in the white colour of the sulphide. The anhydrous sulphide of zinc is not perfectly white, but has a yellow tinge, which is absent in the hydrated sulphide: the latter is produced by passing a current of sulphuretted hydrogen gas through a solution of zinc, either alkaline or containing only a very weak free acid, such as acetic acid. If mineral acids are present, such as hydrochloric or sulphuric acids, the sulphide will be imperfectly, or not at all, precipitated. This precipitated sulphide contains one atom of water: it readily dissolves in acids.

A hyposulphite of zinc is known, but it is very easily decomposed. If zinc is dissolved in an aqueous solution of sulphurous acid, and the liquid is then gently evaporated, sulphite of zinc crystallizes out at first, and hyposulphite of zinc remains in solution. The hyposulphite cannot be obtained in a solid form. Upon evaporating its solution at the ordinary temperature, either in air or in vacuo, a precipitate of sulphide of zinc is formed, and trithionate of zinc remains in solution. This again splits up upon further evaporation, so that, ultimately, there remains a mixture of sulphur, sulphate of zinc, and sulphide of zinc, sulphurous acid having been evolved.

The principal salt of zinc met with in commerce is the sulphate. This is produced in large quantities by roasting ores containing sulphide of zinc; the two elements of this compound absorb oxygen from the atmosphere, the zinc becoming oxide, and the sulphur sulphuric acid, which, combining, form sulphate of zinc. The whole is then treated with water, and the solution evaporated to the crystallizing point. The salt thus obtained is known in commerce as zinc vitriol; it is very impure, but may be purified by recrystallization. This salt is likewise obtained in considerable quantities, when a galvanic battery is in frequent use. The force being generated by the solution of metallic zinc in sulphuric acid, the result of a few hours experimenting with the electric light produces more sulphate of zinc than the operator usually knows what to do with. We have for the last few years been working somewhat extensively on the electric light, and have at various times taken the trouble to collect and preserve the crystallized sulphate of zinc, but the commercial value of this salt is so trifling that we have now come to the conclusion that it is cheaper to throw it at once down the sink than to devote any time to its crystallization or purification. In a chemical laboratory, where large quantities of oxygen gas are frequently required, it might be worth while to preserve the sulphate of zinc with the object of preparing this gas from it. When heated to a bright red heat, sulphurous and sulphuric acids are given off together with oxygen gas; this can be thoroughly purified from the accompanying acids by being passed over slaked lime.

When iodine and zinc are brought together, they combine with slight evolution of heat, forming a colourless iodide of zinc which dissolves upon addition of water, and when evaporated down to the crystallizing point, separates in the form of anhydrous octahedrons. Iodide of zinc, when heated in the air, fuses and partially sublimes in the form of beautiful four-sided needles; the greater portion, however, absorbs oxygen, and gives off iodine vapour, being converted into oxide of zinc, and a similar decomposition takes place when iodide of zinc is freely exposed to the air at ordinary temperatures; it is very deliquescent, and owing to the ready separation of iodine from it, is not a very good salt for photographic purposes.

Bromide of zinc is far better adapted for the use of the photographer than is the one just described. Zinc and bromine do not combine when merely placed in contact, like zinc and iodine, but by passing bromine vapour over red hot zinc, the two combine, forming a colourless liquid, which solidifies on cooling to a crystalline mass. The easiest way to form bromide of zinc, is to dissolve the metal in aqueous hydrobromic acid, hydrogen being evolved. Upon evaporating the solution to dryness, and heating, the residue sublimes in white needles, which are the anhydrous bromide. They

deliquesce rapidly in the air. Unlike the iodide of zinc, the crystallized bromide is not anhydrous, but contains one atom of water: when its aqueous solution is evaporated until a pellicle forms on the surface, and then set aside to cool, it solidifies to a mass of small indistinct crystals. These must be rapidly dried between warm blotting paper, and then transferred to a warm stoppered bottle. Bromide of zinc is soluble both in alcohol and ether.

Chloride of zinc is very readily formed, and is a salt of some considerable value for many purposes. It may be prepared either by the direct action of chlorine gas upon zinc, in which case it is produced in the anhydrous condition, or by dissolving metallic zinc in hydrochloric acid. The solution is rapidly effected with evolution of hydrogen, and when evaporated to dryness, and heated to dull redness, the anhydrous chloride is left behind. When cold, it has the appearance of a whitish grey, waxy, semi-transparent substance, which is excessively deliquescent, and must therefore be kept in tightly stoppered bottles, the stoppers of which should be smeared with paraffin. Fused chloride of zinc is of great use in the laboratory, for drying liquids and gases. Owing to its powerful affinity for water, it instantly seizes upon every trace of this body, and is largely used in cases where the action of chloride of calcium is not sufficiently energetic.

ON PHOTOGRAPHY IN CONNECTION WITH ART.

BY THE HON. LIEUT.-COL. STUART WORTLEY.*

IN the paper I am about to read to you, I shall avoid, as much as possible, wearying you with any of the technicalities of the various processes of photography, being more anxious to draw your attention to the position which photography does hold, and is capable of holding, in connection with the fine arts.

To begin, by alluding to photographic portraiture, as carried on in the present day.

I must first ask you to disabuse your minds of a common error into which most people fall, namely, that a photograph because it is taken as it were by machinery, must necessarily be a likeness.

This is not the case, and, for the following reasons. The photographic portrait lens is not a perfect instrument, and of necessity magnifies the objects that are nearest to it, and makes them out of proportion with those situated in a plane somewhat further from the instrument. To prove this, you have only to look over any collection of photographic portraits, and you will at once see that the hands, or feet, or any object prominently brought forward, are larger than they should be, to be in due proportion. This defect, of course more visible in the case of a hand, foot or other large object, alters the *proportion*, and, indeed, the *expression*, of a sitter's head and face.

If, then, in posing a sitter, you allow the chin to be elevated, or brought forward, it is of course appreciably magnified; and the forehead and eyes being thrown back at the same time, are diminished, and a coarse, foolish expression given to a face that may be full of intelligence and refinement of feature.

This defect is of course much greater in a cheap, bad lens, than in one by any of the best makers; though it is, as I hope you will have understood from the remarks I have made, one that can easily be guarded against.

But now we enter on a wider field, and we get to the true difficulty in photographic portraiture; it is, that without knowledge and taste, it is impossible to give a pleasing and natural pose to a sitter.

Look again at a collection of photographs; you have probably the pictures of many, and doubtless very pretty young ladies in your respective albums. Now, honestly, how many of those photographs do the young ladies justice?

Do any? Are not the majority atrocious libels? In how many of the positions selected by the photographer would a portrait painter have placed his sitter? It appears singular that such an utter want of artistic feeling and taste should be shown in the majority of photographic portraits, but such is undeniably the case. It is not the want of colour in a photograph that makes it so unsatisfactory. You must all of you have come across, occasionally, most charming portraits in monochrome, chalk and crayon drawings, in sepia, and even with pencil and pen and ink, and occasionally a photograph. Shall we try and inquire why the good photograph is the exception and not the rule?

In many cases, the professional photographer has taken up photography as a profession, and so long as he makes it pay he is content. He does it by machinery; he has no knowledge of art, no feeling for the beautiful; and in many cases, as any one can see, is entirely ignorant of the optical properties of his lenses. And the amateur, he takes to photography because it is so nice to be able to get pictures of all one's friends! He gets *photographs* of them certainly, but between photographs and pictures there is a wide chasm, bridged by a narrow plank, across which not many of our amateur portraitists have yet walked, and as few of our professionals.

Honour, therefore, to those who have done so. In the Photographic Society's Exhibition this year some exquisite pictures were shown by some of our leading photographic portraitists. Pictures thoroughly deserving of anxious and careful study by any one desirous of excelling, whether amateur or professional. I cannot, however, call to mind any good portraits by amateurs, with the exception of four medium sized ones by Dr. Diamond.

Perhaps our best amateurs do not like exhibiting the pictures of their relations and friends for criticism. I can sympathise with that feeling; but anyhow the result was that, with the exception above mentioned, amateur portraiture fell very, very far below the results of the professional gentlemen exhibiting.

If I may give a word of advice to amateurs anxious to take up portrait photography, it would be to recommend them strongly to adopt the style of taking the head and shoulders only, making the head about the size of a shilling, and carefully vignetting it, using always a plain background, varying the colour of the latter according to the colour of the sitter's hair, dress, &c., &c.

I now propose to draw your attention to landscape photography, a branch of the art more practised, I think, by amateurs, but requiring on their part more knowledge of high art, more feeling for all that is beautiful and glorious in nature, and more perseverance and hard work before they can attain to eminence. And yet, what a charming study it is; how much better you feel, how much more contented and happy, sitting wrapt in contemplation of the beauties of nature, you forget insensibly the worries and trivialities of ordinary life; you are unconsciously led to think of higher things, to think perhaps of things that never struck you so forcibly before; gentle, peaceful thoughts find their way to the surface out of long unused and long silent depths of the heart; your best, your tenderest feelings all rise under the influence of nature in its witching beauty; and when the time comes that you must return, when the last rays of the setting sun have gathered the last gleams of gold and purple from the delicate clouds floating on the horizon, and left them to put on their sad coloured grey tints, so quickly to turn to black as if mourning his departure, you rise with a sigh, and turn wearily back to commence anew the constant strife and struggle with the many vexations of life, conscious, however, that you have higher hopes, and aspirations; and feeling, if, to use a familiar saying, "your heart is in the right place," an awakening of long dormant emotions, and a quickening, so to speak, of the good seed that lies in the depths of every heart, choked, too often though it be, with poisonous weeds, and having, perhaps, so far quickened it that from that time forth it shall silently

* Read before the Royal Cornwall Polytechnic Society.

and imperceptibly pass from seedling to bud, and from bud to blossom, finally to produce that good fruit fit to be gathered by, as we must all earnestly hope, Him who laid the good seed in our hearts, the great Author of all that is beautiful and wonderful in Nature, the All-Powerful.

Yet, it is not only a charming, but it is, to those who have a feeling and a love for art, an entrancing study; and by a feeling for art I mean that intense appreciation of the beauties of nature that leads us not to be satisfied till we have, in our humble way, done our best by means of such arts and such contrivances in our power, whether drawing, painting, or photography, to reproduce faithfully what we most love and enjoy in nature; and I maintain that the highest art, the purest taste, is shown in the most scrupulously faithful transcript from nature itself; because nothing, and no imaginary form or colouring can equal, or, I might indeed say, approach, in beauty what we, if we care to look for it, and know how to find it, can find for ourselves in nature. And it is pre-eminently this earnest desire to seek for and discover the beauties of nature, and the knowledge of how and where to find them, that distinguishes the artist from the mere painter or photographer. No one shows this more strongly than our great landscape painter, Turner. His glorious sunsets, his magnificent effects of light and brilliancy, the exquisite beauty of his landscapes, are only the truthful results of his careful and conscientious study of nature, and his constant communing, so to speak, with nature; and that study alone made him the great and wonderful painter that he was.

It is hardly possible to over-estimate the influence exercised by the study of nature and art on the masses. In a most able lecture, by Lord Stanley, on "Art Education," he takes occasion to mention his conviction that the power of appreciating the beauties of nature and art is greater in our own countrymen than in the inhabitants of any foreign land. I have long had the same opinion myself, founded on my personal experience abroad; and it is this that leads me so earnestly to urge upon my present hearers the study of nature, confident that they will open for themselves a new fund of enjoyment and interest, of the delights of which they have previously had but little conception.

I am afraid you will think I have needlessly inflicted this long digression upon you, but it is not so. In this lies the germ of what I am anxious to bring before you, that if you aim at art in photography you must study nature, and you must give as faithful a transcript of nature as you can. You are all of you familiar with the style of photography that I can only call the photographing of the foregrounds, the glorious beauties of the sky being represented by a piece of white paper. How singular it is that anyone can be contented with such productions when more study and more care would enable him to produce pictures and not only photographs. No one of late years has done so much for art photography as Mr. Wilson, some of whose charming representations of water and sky you have doubtless seen. I am quite sure that in no view where it is possible would he now be contented to take a photograph without giving as faithful a representation of the sky as of the landscape.

Suppose a painter were to say, "Well I cannot be at the trouble to do skies or clouds to my landscapes, people must be content with carefully painted foregrounds," what should we think of that individual? who would look at his pictures? what would the photographer himself say to them? Then, what does he imagine artists and all who have a feeling for, and a love of, nature, think of his photographs? I hold all such productions to be unfaithful to nature, and untrue to art.

Then, if any of my hearers have any idea of taking up photography as an art, I hope they will commence with a determination not to be content till they produce photographs as faithful to nature as possible, and thus rendering them worthy to be classed as artistic productions.

They need not despair of being able to do this; one of the best pictures in the Photographic Society's Exhibition

was by an amateur, Sir A. MacDonald; a piece of rock scenery and sky—a truthful and beautiful study. Many professional gentlemen have taken charming scenes. Messrs. England, Blanchard, Rouch, and others, have all made their processes public. There is no difficulty that is insurmountable; why then do the vast majority remain on the lowest round of the ladder, contentedly watching others climbing nearer and nearer to the summit.

But in addition to the real feeling for the beautiful, some *knowledge* is desirable, some study of the works of celebrated painters, in order to know how to combine the various beauties of nature.

To give an illustration of my meaning:—A view may be very beautiful from a certain point, but it might happen that by moving two or three yards one way or the other, you may make exactly the same view more available, as a picture, by including some object for the foreground, such as a mass of rock, an old gate, the trunk of a tree, or any object that may happen to be within reach.

Attention to this is conspicuous in the works of a talented photographer, whose name you doubtless know, Mr. Bedford.

There are many other branches of photography to which I might call your attention; the copying of pictures, photolithography and its various processes, and composition photography. But I am, in this paper, anxious to confine myself to photography in connection with its claims to be considered as a fine art.

Composition photography, more than any other, shows how difficult it is to attain really artistic results in photography, and shows most forcibly the weak points of photography in its claims to the rank of a fine art. Wonderful results may be achieved considering the means at our disposal, but the insurmountable difficulty of controlling the sitter's expression of face, not to mention other minor difficulties, will always prevent that class of photography from rising beyond a certain level, and will always remind us that photography has much that is mechanical, and that it is necessary to obtain far greater rapidity than any process at present possesses, before composition photography can worthily assist in claiming for photography in general the dignity of a fine art.

In conclusion, I should strongly recommend an amateur to adopt a rapid process, so as never to have any difficulty in getting life into his pictures. A man in the foreground, a cow, a waggon and team, give life and reality to a photograph, and are often of the utmost value, and even necessity, to the composition of the picture.

In the present state of photography, with the minutiae of the processes carefully laid down by experienced photographers, two or three months' hard study should make any lover of nature and art an accomplished photographer; and, if he knows somewhat of chemistry, or studies it a little at the same time, so much the better.

I find myself offering a great deal of advice, much more, probably, than any one will ever take, but I must add a little more still. In taking up a process, see that you take up one practised by somebody whose productions bear out what he says; it is no use being told by Mr. A, or Mr. B, in a photographic journal, that by the use of such and such a formula he obtains better pictures than any one else. Where are they? Perhaps he sends the Editor of the paper one good specimen, keeping his ninety-nine bad ones at home. Books and pamphlets on photography are plentiful, letters written to the journals are legion, and yet, I doubt if one in every twenty authors has ever shown a really good picture. And, when you take away the standard works on photography, by Messrs. Hardwich, Sutton, Hunt, Lake Price, and one or two others, the three first being accomplished chemists, as well as photographers, few, indeed, are left of which the authors are known as accomplished photographers.

Many articles are written solely with trading motives; they declare a certain process can only be worked with Mr. C's collodion, or Mr. D's acid, or printed on Mr. E's paper, and are very, very full of humbug.

Many of the most eminent photographic chemists are hardly ever mentioned, except occasionally some one draws attention to any new or very superior article made by them. They have no need of such shallow puffing, and never resort to it.

In giving you some guide to a process that you would be wise to adopt, I have already made mention of three or four of our most eminent men, the minutiae of whose method of operating have been fully published. Many others have written most valuably on the subject, Major Russell, Mr. Vernon Heath, Mr. Wharton Simpson, and many whose names I do not at this moment recollect; and any photographer in difficulties will always obtain advice and assistance from the Editors of either of the photographic journals, of which we have four, all the gentlemen in question being thoroughly at home in chemical, as well as artistic knowledge of photography. I may mention here that my own pictures were obtained by a process devised by myself two years ago, the main points being a large amount of bromide in the collodion, liberal use of nitric acid in the bath, which must be made of the purest silver, and formic acid in the developer. *Carefully* using these in their proper proportions, which constant experiments enabled me to obtain, I consider that I can obtain my pictures with as great rapidity as the quality of the light will allow; and where the light is good and clear, I am unable to open and close the lens with sufficient rapidity.

If I have in any way given one of my hearers a bias towards attempting artistic photography, I shall be very glad. I am confident that by photography pictures are to be obtained far superior to anything else ever produced in monochrome, and any one can obtain these by study, always allowing that they have the feeling and taste for nature and art to begin with as a foundation; and people will soon begin to see that, in the rendering of the effects of nature, photography has in many cases no equal; artists will take it up and make it the handmaid to painting, and with its truthful power and delicate sensitiveness, it can be of the greatest assistance to them; for whatever effects may be chosen as subjects for painting, Nature, in the first instance, must be taken as the guide; photography can imitate Nature as *truthfully* as it is possible without colour, and truth is everything. It has ever been, and ever will be,

Magna est veritas, et praevalabit.

JOTTINGS FROM THE NOTE-BOOK OF A "PHOTOGRAPHER'S ASSISTANT."

No. III.

THE USE OF NITRATE OF SODA IN THE PRINTING BATH.

THE subject selected for this, our third "jotting" is one that demands the serious attention of every professional photographer, for an adoption of the modified formula for sensitizing albumen papers, we are about to propose. Whilst improving pictorial results, it will confer pecuniary advantages, which of itself is sufficient to render it worthy of something more than a passing consideration, as a saving of something like 75 per cent. will be effected in the consumption of that expensive material, viz., nitrate of silver.

The necessity for the employment of a strong nitrate bath has always been imperatively urged by every writer on photographic printing, and the reasons advanced invariably tend towards one point, viz., the coagulating influence exercised by the nitrate salt upon the albumenized surface of the paper. To enter fully into this interesting subject would require more time than we have at command; our remarks must, therefore, of necessity be brief; but we hope the arguments we are about to advance will sufficiently prove the second point named for discussion in the present paper:—The unscientific and expensively wasteful method adopted for producing coagulation (so called). We say "unscientific," because science, when genuine, aims at

simplicity, combined with the strictest economy, and every law of nature teaches that the greatest success is attained when the smallest amount of material is judiciously employed.

The appearance of albumen, as obtained pure from the egg, is familiar to every person; but the change this substance undergoes during the process of spontaneous drying does not appear to be so generally understood, as there are many intelligent writers on the subject who still entertain a belief that dried albumen is coagulated when exposed to a high temperature or to the action of certain metallic salts. The effect named is certainly produced when albumen undried is the substance experimented on; but we are inclined strongly to believe that during the process of drying its properties undergo a peculiar change, not merely by a modification in its molecular arrangements, but from a naturally produced separation of its life-yielding principle which, once removed, cannot by any means be restored; and with the loss of this substance the albumen loses all tendency for coagulative change. When exposed to the action of silver in solution, in obedience to the laws of chemical affinity, a combination ensues, the results of which is the production of an organic compound known as the albuminate of silver, in which condition the properties originally found in the albumen are altogether lost. The soluble tendencies no longer exist; but it must be remembered that the insoluble conditions are not perfected until the chemical change is entirely effected; hence the necessity for producing the union before the water has exercised its solvent influence to a perceptible extent. Where silver alone is employed, if the solution is at all weak, the horny surface of the albumen, before it can effect a union with the metal, is partially dissolved by the solvent influence brought to bear on it by the water. It is, therefore, necessary that a liberal allowance of the metallic salt be provided, in order that the resistance might be quickly overcome, which modifies the evil to a great and beneficial extent, so far as results are concerned. But the cost renders it doubtful whether the advantages are not too dearly purchased, because there is so much uncertainty in the matter for the following reasons:—Every sheet of paper floated withdraws from the solution a certain quantity of silver; consequently, the bath becomes more powerful in its solvent action on the freshly produced albumen. To prevent this, the method adopted is to add an occasional dose of strong silver solution, which prevents what it cannot effectually cure. This style of doctoring is not merely expensive, but wasteful, as a large portion of the valuable salt is lost during the tediously prolonged washings its presence renders requisite; and, in addition to this, the free nitrate borne on the surface of the print to the toning bath assists materially to produce the dreaded mealiness.

The foregoing arguments will be supported by the remarks we now offer in favour of a salt whose peculiar properties, when known, will secure for it a prominent place in every printing laboratory. The salt referred to is nitrate of soda.

The influence exercised by this salt would appear somewhat paradoxical if, in experimenting, we lose sight of the difference that exists between pure dried albumen and albumen in combination with silver. The first-named substance, when exposed to the action of a nitrate of soda solution, is completely dissolved, so that the paper has no remaining trace of it left on its surface; but when the last-named combination is subjected to the same conditions, the results are quite different; not the slightest change, neither in weight nor colour, has been effected, nor has its brilliancy been tarnished to the smallest degree. What does this prove? Why, that albuminate of silver is insoluble in a nitrate of soda solution; also, that its solvent influence on pure albumen might be made useful, as it combines mechanically with silver, assisting rather than interfering with its duties. The obstruction offered by albumen is purely of a mechanical character. Its atoms must be loosened ere the silver can gain access to them. The quicker this is effected, the sooner

will the union ensue, because the affinity is powerful in its nature. The nitrate of soda loosens the atoms referred to, but before they are separated the silver unites and an insoluble substance is formed. This explanation, wild or improbable as it may appear, may be tested by a few simple experiments.

Make an 80-grain solution of nitrate of soda, on the surface of which float a piece of albumenized paper; when dried, no trace of albumen will remain.

2nd. Float another piece of paper on an ordinary silver solution; dry, and float a second time upon the soda bath; when dried, the surface will appear as perfect as before.

3rd. Take a piece of paper that has been floated in the silver bath, and place its sensitized surface on pure water; dry, and expose with the last to light; that submitted to the soda bath will colour vigorously, whilst the other will be insensitive, and colour sparingly.

4th. Excite a piece of paper on a 35-grain silver solution; dry. Now add to each ounce of the above 80 grains of nitrate of soda. Float another portion of the same sheet of paper; dry; then compare results, both in appearance and printing properties, when it will be found that in both respects the last portion of paper experimented on will be infinitely superior to either of those sensitized under the conditions present in the other experiments. And now it remains to test whether the improvement is produced by any chemical combination between the albumen and soda.

Sensitize a portion of paper; dry, and weigh carefully. Now float on the soda solution, dry, and weigh it a second time, when it will be found that no addition has been gained or loss of weight sustained.

There is yet another advantage gained by the use of the salt whose claims we advocate; in addition to the saving effected, its use will decrease to a considerable extent the proneness of some papers to mealiness, loosening the atoms of albumen in the manner we have described, will enable the silver to penetrate to greater depths, and the bleaching power of ordinarily constructed toning baths will have more substance on which to exercise their devouring appetites. To those who use india-rubber or enamelled papers, we strongly recommend the nitrate of soda: the papers named are very slightly coated with albumen, so that to attain good results the slightest portion of the last named substance cannot be spared; for, except the picture is formed on the albumen, toning to a satisfactory colour will simply be an impossibility. In concluding the present paper we name the proportion which experience has proved to be best. Nitrate of soda, 80 grains; nitrate of silver, not less than 35 grains per ounce; a practiced eye is necessary to distinguish a deficiency of either salt, but as the soda wastes but little, any weakness in the appearance of the print may generally be remedied by an addition of silver in small quantities. Before laying down our pen, we would just add one remark, as it will be seen that we pretend to introduce here nothing new, save an attempt to reduce the operation of sensitizing to something like system; for, whether we work out an original idea, or introduce the suggestions of others, except system attends our undertakings, success and failure must remain trembling in the uncertain balance of Chance.

PHOTOLITHOGRAPHY.

BY JOSEPH LEWIS.

No. IV.

VARIOUS METHODS OF PRODUCING AN IMAGE ON STONE.

THE Lithographic principle is so purely chemical, that any means of effectually carrying out by that process the printing of the photographic image must depend more or less upon the same laws. It is worthy of remark that there is scarcely a photographic process but may, by sensible dexterity, be turned into a means of producing a lithographic printing surface. To produce a printing plate or block, a large amount of material must either be taken away or added, so as to alter the figure or level of the surface. With lithography it is dif-

ferent, the slightest film of grease or gum produce either a black or white result on the stone. The power possessed by light and air to decompose a greasy substance, producing a film insoluble in the hydrocarbons, as we have seen in the transfer process described at page 403, furnishes a ready means of securing the proper deposit of fatty matter on the stone to produce a printing foundation. I come now to consider another process, the converse of that above alluded to, both of which come under the second head in our classification.

I have already stated that the stone is so exceedingly porous and absorptive that it is difficult to dislodge any substance if once imbibed by it; yet there are means within reach of indirectly effecting that purpose, as in the following process. (2) I take a clean stone and spread over it a thin film of saliva or very dilute isinglass; when dry I coat it evenly by means of a composition roller with the preparation of bitumen, suet, &c., described at page 403; when the film has become hardened, the negative may be applied and exposed for several hours according to the intensity of the light. A mixture consisting of turpentine, 4 oz.; a few drops of nut oil, also of bisulphuret of carbon, are to be added; to these I put an equal volume of thin gum water, and shake well together, the negative being removed; the stone is covered with this mixture and gently rubbed with a soft sponge, adding printing ink to charge the work; by this means the image is gradually developed and prepared for printing. The features of novelty in this process consist, first, in the primary preservative preparation of the stone by saliva or other similar neutral substance, whereby the sensitive and oleaginous ingredients are prevented from penetrating the stone until they are *changed* by light; second, the combining proportions of the alkaline bichromate with the resin and the fat, so that by the oxidizing influence exercised by light and air they become saponified, and in that condition are able to permeate or corrode the saliva film, thence into the stone. Ordinary printing ink cannot penetrate a thin film of gum or isinglass; but if soap or an alkali be added, it does so readily.*

Third, the nature of the solvent employed, the peculiar manner of using it, by mixing the gum water with the turpentine, &c. The addition of the gum water and oil to the turpentine causes a film of grease to deposit upon the insoluble parts that would be effectually washed away, if turpentine only was applied.

(3.) The stone in this case is rendered more effectually non-absorbent either by an etching with gum and acid, or, what is better, by an alkaline solution of silica, to be more particularly described hereafter. This being effected, it is evenly coated with a solution of bitumen in bisulphuret of carbon, to which a very small quantity of Canada balsam has been added. Upon this a reversed positive is placed, and after exposure for several hours in good light it is to be washed in a mixture of bisulphuret of carbon and turpentine, equal quantities. The fixing being effected, the stone is washed over with a solution of alum or acetic acid, which possess the quality of decomposing the non-absorbent coating on the stone, and so prepare it in those portions where it has been left bare by the solvents for the reception of the printing ink.

LACTATE OF SILVER FOR THE BATH, AND LACTATE OF IRON FOR THE DEVELOPING SOLUTION.

BY M. MC A. GAUDIN.

I AT first prepared lactate of silver, by the action of lactic acid upon oxide of silver, but did not succeed by this method,

* By the practical application of this fact, when the penny postage stamp was introduced, I proved the inefficient nature of the obliteration mark, having coated a Queen's head (then printed in black ink) with a thin coating of made starch. The letter was posted and obliterated in the usual course. My confederate, to whom the letter was addressed, received it, and in presence of the postman washed off the obliteration by a single application of his wetted finger. By this means the same stamp may be used perpetually, and by the same principle the transfer process of Mr. Osborne and Colonel James are effected.

as it was a black mud, of which it was impossible to make any use. I succeeded better by making lactic acid react upon *carbonate of silver*. After filtration through paper, we obtain a yellow liquid with excess of lactic acid, but this bath is much too reducible; it must be largely acidulated with nitric acid: even by using this corrective, we do not attain to the sensibility of the ordinary nitrate of silver bath, which I had hoped to be able to surpass. But this bath of lactate of silver possesses a peculiar property; it can be employed very *weak*, without letting the sensitive film detract itself from the plate, as with the ordinary nitrate of silver bath, under the same circumstances; and moreover, *it does not dissolve the iodide of silver*: so that there is no fear of its forming spots, in consequence of its concentration by evaporation, as always occurs with the bath of nitrate of silver, however short a time the sensitized plate remains in the slide. With this lactate bath, the sensitized plate may probably remain out of the bath an hour without injury. This, however, remains to be proved. On the other hand, lactate of silver is constantly undergoing modification with time. At the end of four-and-twenty hours, it becomes of an intense yellow colour, and requires a fresh addition of nitric acid to work with.

As to the lactate of iron for a developer, it requires an addition of sulphuric acid to fit it for use. The negatives it yields are exceedingly fine, analogous to those obtained through pyrogallic acid; they are blue by reflected light, and red by transparency, like those developed by protoacetate of iron, but the whites never come pure.—*La Lumière*.

IODIDE OF SILVER IN COLLODION.

BY M. MC. A. GAUDIN.

WE may introduce as much iodide of silver in suspension into collodion as we think proper, *without fear of fogging the pictures by leaving the collodion in the light, or in pouring the collodion on to the plates in the open air*. The presence of the iodide in solution in collodion renders this iodide of silver absolutely insensible to luminous radiation, and is therefore an excellent means of augmenting the porosity of the collodion which remains opaline after being filtered through the most compact cotton. I have not yet satisfied myself if the collodion gains in sensibility; and here perhaps an obstacle presents itself. Sensitized collodion is as impenetrable to actinic rays as orange yellow glass, although its hue is much paler; in this particular it is superior to bright yellow paper, so that in reality sensitized collodion is attacked by a strong light only, at its surface on account of the colour of its particles; it is on this account that there will be more advantage in introducing some bromide, chloride, or cyanide of silver, which are perfectly white, into the collodion, than in introducing iodide of silver in suspension, so that the perfection of collodion will very probably come to consist in a combination which will admit of a soluble iodide in very minute proportions, sufficient only to guarantee the argentiferous compound in suspension from every attack of light, and to form at the moment of its sensitizing the iodide of silver necessary to commence the attack under the influence of the least actinic action.—*La Lumière*.

OXIDE OF SILVER PRINTS.

BY F. F. THOMPSON.*

PREVIOUS to the removal of my "Den," a few months ago, I made a few very satisfactory prints by the oxide of silver process, and was so pleased with it that I am determined to adopt it in my future operations. I hope at the next regular exchange to send the club prints made with only fifteen grains of silver to the ounce of water in the floating bath.

The process is thus:—

Nitrate of ammonia	3 ounces.
Filtered water	10 "

* *Amateur Photographic Print.*

Shake up; and when thoroughly dissolved, add moist oxide of silver to saturation.

The moist oxide is made by adding to a pint of 20-grain solution of nitrate of silver, caustic potash, till all the oxide is thrown down. Wash the precipitate clean from all traces of potash, and put it while wet in the nitrate of ammonia solution. There will settle to the bottom the surplus of oxide of silver, which serves both to keep the bath saturated and clear.

Add three drops of nitric acid to each ounce, and sensitize the paper by floating half a minute. After the paper is dry, fume it with ammonia in the usual way, and print as ordinary. Should the albumen dissolve in the floating bath, then add more nitric acid to the bath, and fume for a few minutes longer.

A NEW METHOD OF ASCERTAINING THE ANGLE OF APERTURE OF A LENS.*

IN the first place, it is necessary to have the expression "angular aperture" so defined that the teacher and student may understand each other. The angle of aperture of a lens or combination is that angle which is bounded by those external rays of the maximum pencil which, after refraction, is brought to one and the same focus on the other side of the lens or combination.

The opening of a lens or combination is the amount of surface exposed, and is measured by the angle formed by lines drawn from the centre of the object to the periphery of the glass surface.

Let PTGLHSN be a double convex lens, ABC the object,

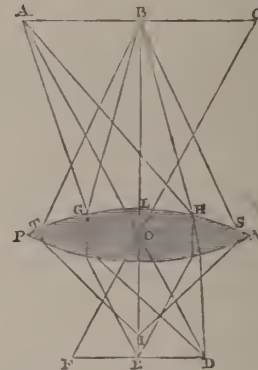

and DEF the picture of the object. The axes of the radiant points A, B, and C will be BOE, AOD, and COF. Now if BG and BH are the limits of the largest pencil that can be transmitted through the lens and brought to one and the same focus, E, then GBH will be the *angle of aperture*; and that part of the surface of the lens comprehended by the arc GLH is all that is required for effective work, or all that is available in producing clear definition; for supposing the lens to extend on either side as far as T and S, the rays TB and BS will be the boundaries of the conical pencil from the radiant B; but these rays after refraction are brought to a focus at I, and all intermediate rays between TG on one side, and HS on the other, will cross after refraction on the axis between E and I, and produce, in connection with the oblique pencils, a blur or haze, on the central part of the picture, which is commonly denominated the *ghost*.† This ghost will always be visible on pictures produced by lenses that are not thoroughly corrected for spherical aberration, or in which there is an excess of surface exposed over and above that which is required for the transmission of the largest pencil that can be refracted to one point.

Thus, then, the surface or arc TGLHS is the *opening of*

* From *Humphrey's Journal*.

† Other causes conduce to produce the *ghost*, which I will explain in a subsequent article.

the lens; but the parts TG and HS tend to produce the ghost, both with the direct and oblique pencils, and are detrimental to the lens, and consequently altogether unnecessary. Now the angle TBS represents the angle of the opening of the lens, but it is not the angle of aperture which measures the *defining power* of the lens.

By peculiarities in lenticular combinations—which can be calculated mathematically—two lenses may have exactly the same magnifying power, and yet be quite different in regard to angular aperture, and, consequently, varying in optical value to the ratio of the superior angular aperture; for the lens with a large angular aperture transmits a large pencil of light, and thus produces a very brilliant picture, whose parts are more easily designated, whether applied to microscopy or photography.

We see at once, then, the absurdity of regarding the illuminated circle or picture on the ground glass of the camera as a criterion by which to judge of the value of the lens, as long as this illuminated circle is not equally sharply defined from the centre of the periphery. If on the contrary, however, every part is equally sharp, then this circle becomes the base of the cone whose sides bound the angular aperture.

A thoroughly corrected lens, whose angular aperture is of the same size as the lenticular opening, is recognized in the following manner:—Place the camera on the camera-stand and focus an object, as, for instance, a church steeple, whose base is in the centre of the circle and the spire in the periphery; focus the central part perfectly sharp; the spire will also be sharp if the correction is perfect. Or move the camera to the right or left so that the base of the church steeple is visible on the peripheral parts of the circle; if it is still in focus and sharp, the lens is correct. But most lenses will not bear this rude ordeal. Like many individuals attired in gorgeous apparel, the vesture is no criterion of the man; nor is the *size* of the illuminated circle a test of the value of a lens.

The result, in either case, is the same, namely, an equally sharp picture from the centre to the edge.

This picture, then, is the base of a cone whose sides bound the angular aperture, or working power of the lens, and this angle we wish to measure.

We will suppose, however, that the circular picture of a landscape, for instance, with a given lens is not equally sharp upon the whole surface—what is to be done?

Put in the smallest stop and then examine.

Supposing by this expedient the error is not thoroughly corrected—what next?

Elongate the cylindrical tube in front of the lens so as to exclude oblique rays, and examine once more. By this expedient the illuminated circle will gradually be diminished as the elongation is increased, and the picture will receive an increase of sharpness.

We will finally suppose that the error is not yet thoroughly removed—what is our next step?

To diminish the opening of the lens by means of stops immediately in front of it, as well as to apply the elongated cylindrical tube so as to shut out oblique rays, until finally a small sharp picture is obtained that is regarded as in every respect satisfactory.

The picture so obtained is a part of the panorama before you; it is, however, in the form of a circle, and has to be cut down into the form of a square. Knowing the diameter of the illuminated circle we can easily calculate the side of the inscribed square, which is equal to the square root of twice the square of the radius of the circle.

Place the camera-stand on an open plain, or on the flat roof of the tower of a church, etc.; level the platform and insert the camera between the ledges; it is evident that, when so placed, the axis of the lens divides the horizon into two semi-circles of 180° each. We propose, therefore, to compare the semi-circle with the angular width of the square picture.

To do this we focus the landscape and observe very care-

fully so as to recognize some object on the left side of the illuminated circle. As soon as this is done, keeping the object all the time in view, we move the camera carefully so as not to disturb the position of the camera-stand, until the object that was originally on the left side of the picture is now on the limit of the right side. Reckoning from the axis of the lens when we started to the limit of the picture now, we have taken in one circle and a half of the panorama on the ground glass. Fixing your eye again upon an object on the left, move the camera to the right until this object is seen on the right-hand limit; we have now two circles and a half from the starting point. Proceed in this way until the camera has been completely reversed on the stand, and ascertain the number of circular pictures and parts of a picture that are comprehended in the hemisphere. This number, whatever it may be, is the divisor, and 180° the dividend; the quotient will be the angular aperture of the lens.

Supposing the circles and parts of circles added together make three and nine-tenths, then 180 degrees, divided by three and nine-tenths, will give 46 degrees, 9 minutes, and 13 seconds for the circular angular aperture of the lens so tested.

One of Harrison's globe lenses for stereoscopic purposes thus tested—assuming the circular picture to be equally sharp to the edges with oblique rays, which is certainly not the case—gave a circular angular aperture of about 60 degrees, which, when cut down to the panoramic square, will be about 42 degrees.

We do not speak (with any preconceived idea) in disparagement of the globe lenses; we are of opinion, however, that, inasmuch as the illuminated circular picture is much larger than required for stereoscopic purposes, and not quite sharp to the edges, it would be a decided improvement to furnish the tubes with cylindrical prolongations in front, so as to shut out a quantity of oblique rays that tend to destroy the uniformity of the illumination.

Proceedings of Societies.

SOUTH LONDON PHOTOGRAPHIC SOCIETY.

THE first meeting of the winter session was held in the City of London College, Leadenhall Street, on the evening of Thursday, September 8th, the Rev. F. F. Statham, M.A., F.G.S., in the chair.

The minutes of a former meeting having been read and confirmed, the following gentlemen were elected members of the Society: Messrs. May, Auther, and A. H. Wardlow.

After regretting that a misunderstanding regarding the announcements had issued in a failure of the out-door meetings this summer, the Secretary called the attention of members to the fact, that subscriptions were now due, and should be paid not later than the next meeting night; members wishing to forward them, might do so to the Treasurer, Mr. Noel E. Fitch, 13, Union Street, Borough.

Mr. WALL brought for the inspection of members, a drawing in black and white chalk, with a gold background in the mediæval style, by Mr. Reijlander, being a copy of his recent photograph of Tennyson. The drawing was very severe, round and forcible, and exceedingly truthful. It illustrated one use of photographs to the artist, who might, from two or three imperfect prints, produce a drawing equal to one perfect photograph, with other added qualities which he might desire. In this instance, in addition to the properly printed photograph for general effect, a darker copy had been taken to get the drawing in the lights, and a light copy to secure detail in the shadows. A perfect photograph possesses, of course, perfect light and shadows, connected with the duo gradations of half-tone in each, all in their proper relation, but in producing something for the painter to copy or paint from, it is sometimes desirable to produce copies slightly exaggerating parts, such as the detail in lights and shadows, to render them more obvious.

Mr. WALL also exhibited a fine reduced copy of Reijlander's "Two Ways of Life," and some prints by the same gentleman as illustrations of the power of photography to render expression; also a burlesque photograph in which the effect of Millais'

"Eve of St. Agnes" was imitated by a young woman engaged in what is known in the laundry as "dollying." He also called attention to a very fine solar camera picture by Mr. Sidney Smith, produced on tinted drawing paper, and very effective.

Mr. WHARTON SIMPSON exhibited a charming subject picture by Mr. H. P. Robinson, entitled "Somebody Coming." A pretty little rustic girl, sitting at a stile, looks archly round to tell another older companion that somebody is coming, whilst the half-averted and coy face of the elder girl plainly indicates her feelings to that "somebody." The picture is from one negative, 12 by 10, is exquisitely round and soft, and was pointed out as a fine illustration of the qualities of Blauchard's bromo-iodized collodion. Mr. Simpson also exhibited a very handsome album, got up by Messrs. Marion purposely for Mr. Wilson's album pictures, which are about 4½ inches by 3 inches. The album was filled with fine specimens of Mr. Wilson's recent labours, some of which were cleverly coloured. He also exhibited an album with some fine card pictures of Irish scenery by Dr. Hemphill. Mr. Simpson also showed a moonlight negative by Lieut. Noverre, containing the moon, moonlit clouds, and the traces of a landscape and foliage. When prints merely were shown, he observed, it was easy to suspect that some dodging or trick might have been practised. But here was the negative; the moon sufficiently defined to give its markings, together with the other objects he had just mentioned, a practical answer to those gentlemen who had pronounced the thing impossible. The negative was taken with Dallmeyer's No. 2 Triple lens, full aperture, bromo-iodized collodion and iron development: exposure about 20 seconds.

Mr. ALFRED HARMAN exhibited a very fine print from an enlarged negative.

Mr. HOWARD showed some good pictures by the Fothergill process.

Mr. HARMER exhibited some interesting specimens of his success in transferring the albumen film to opal glass.

Mr. BLANCHARD showed some exceedingly perfect pictures, consisting of whole-plate studies, to show the qualities of his collodion with simple iron development.

Mr. JABEZ HUGHES showed some charming card pictures of the Princess Louise and others.

The CHAIRMAN showed some cards he had purchased in Italy, and a print with several medallion heads, by Mr. Dean.

Mr. WALL then read an opening paper entitled, "A Few Thoughts about Photographic Societies." (See p. 486.)

The CHAIRMAN in proposing a vote of thanks, remarked that Mr. Wall's remarks on the dearth of practical papers was illustrated by the fact that he had been driven to photograph the societies themselves.

Mr. HOWARD agreed with Mr. Wall on the subject of Exhibitions. They ought not to be regarded from a monetary point of view, and he thought the funds of societies could not be more properly spent than in promoting exhibitions; and charging exhibitors for space appeared something like a trading speculation. If there were no funds, it might be another question. Regarding the light estimation photographs received from the public, one reason was, he thought, the ease with which something, however poor, might be produced. As all kinds of appliances continued to improve, so would photographs, and they might eventually command a higher position. He thought too, that the present method of toning and fixing, tending as it did to greater permanency, would elevate the art.

Mr. SIMPSON in reply to a question from the chairman, said he had no especial remark to make upon the paper, the greater part of which would, he thought, command general assent. There was one part of it, however, to which he must take exception; and whilst he did so, he would deprecate all further discussion of it at that meeting. He referred to the observations on Photographic Societies charging non-members for exhibiting space. The fact that the Photographic Society of London, generally spoken of as the parent society, had only a few weeks ago announced that, in future exhibitions, they must make such a charge, gave Mr. Wall's general remarks a definite and specific bearing; and he thought it would be very bad taste indeed, for another society to discuss the matter at all. If they were themselves contemplating holding an exhibition, there would be some reason for discussing the question; as it was, it came before them *à propos* of nothing, and appeared very like meddling with what did not concern them.

Mr. WALL said he had, at the commencement of his paper, guarded himself from particular applications, by stating that

his remarks had only a general bearing. He thought that it was quite a legitimate subject of discussion.

Mr. SIMPSON still must deny that it was either a legitimate subject for them, or that it could be discussed generally. It was a subject which could not be discussed without relation to circumstances, and the recent announcement of the parent society gave it at once a personal bearing.

The CHAIRMAN suggested, that if any further remark were made on the subject, care should be used to avoid personal or specific allusion.

Mr. JABEZ HUGHES thought it impossible to enter into the subject at all, without being personal, and he must protest against this society discussing the subject, as it could not be considered in the abstract. They could not then enter into the reasons which had induced the parent society to take such a course, which, probably, was necessary; but at present, and for this society, he thought it wisest to hold their tongues, and say nothing at all. Regarding the paper generally, he thought, perhaps, Mr. Wall had scarcely done justice to the great good which photographic societies had effected. He believed that the position of photography at the present day was largely due to societies. Without photographic societies and photographic meetings, photography could not have advanced so rapidly and so certainly as it had done. Perhaps no better illustration could be given than the history of alkaline gold toning. Without photographic societies and photographic journals, such an improvement could not possibly have reached photographers so rapidly. By means of societies, it not only reached photographers rapidly, but its results were shown, and by their means, and the impetus given by Mr. Hardwich, the process was disseminated and accepted at once and photographers generally were now deriving the benefit. Another illustration might be found in the history of bromo-iodized collodion. Without societies and journals, it was probable that a knowledge of its value would have been kept as a kind of trade secret, known to one or two persons, whilst other photographers would have constantly wondered at the superior softness, delicacy, and clearness of their pictures; and photography generally could not have held the position it now held. He might, moreover, point to the improved artistic state of photography, as being largely due to the action of this South London Society, and Mr. Wall, as its secretary, in calling attention to the artistic deficiencies of photographers, and to the abominations, now almost passed away, of white paper skies. Whilst, then, aiming at improvement in societies, he thought they should never forget how much they had already effected.

Mr. WALL said, it was because societies had done so much good, that he wished to see them assume a character which promised stability. Many useful societies were dead, having died out for want of being established on a better and more permanent basis.

After some conversation on the possibility of promoting social meetings amongst photographers, or of establishing something like a club, and on some other subjects, it was announced that Mr. Warner would contribute for the next meeting a paper on photography in India and warm climates; that Mr. A. Harman would bring some illustrations of the effect produced by light and heavy salting of albumenized paper, and that Mr. Hart would bring some instruments to facilitate accurate estimation of the amount of silver or gold salts in given solutions.

The proceedings then terminated.

Correspondence.

TRANSFERRED ALBUMEN FILMS.

DEAR SIR,—Can you or any of your correspondents inform me how to make or procure a good opal varnish? Perhaps I ought to state the use I wish to make of it. It is this—to coat a curved glass with it, either before or after an albumen film has been transferred on to it (the glass) by the new process, as I think that for brooches, &c., photo-diaphanic will prove almost invaluable.

In the comparatively few experiments I have made with this process, I have found that, upon removing the print from the hypo, the surface on no account should be touched,

as the film is so exceedingly tender that it is sure to tear if meddled with; and when the print has been trimmed to the proper shape, of course it is spoiled by the least tearing or abrasion of the edge. The best way to remove it is to slip a plate of glass underneath. As soon as the print is placed in water, the film separates; it must now be left untouched for about half an hour, when it will have become tough, and may be carefully handled. The larger the quantity of water into which the print is first placed, the better. I only made these notes for the benefit of those who are about to make their first attempt in this exceedingly elegant and fascinating process. Another thing that I found tiresome at first was the thorough washing of the film, which is absolutely necessary.

The following was the most successful method:—Have ready several large basins filled with water, one more than the number of prints to be transferred. Upon removing from the hypo (in which no more prints must be fixed at a time than will lay at the bottom of the dish without touching each other), place *one print* in each basin, and, for the reason previously mentioned allow them to remain half an hour. Now have a dish of requisite size—if the print be very small, a saucer will do—and with it remove one of the films into the basin containing clear water. Fill the basin from which it was removed with fresh water, and place one of the other films in it, and so on, till they all are thoroughly washed. Care must be taken not to pull the film too tightly across the article on which it is placed, or else, upon drying, it will be found to be full of minute cracks. This inconvenience will also be experienced if the film be not sufficiently washed.

I give warning to all those who have not tried this process, that a great deal of patience will be required to bring it to a successful termination. I should like to see some fidgety, testy, old gentleman trying to catch a film in the right position on a curved piece of glass!

Amateurs are sure to have several friends who think there is no trouble involved in photographic operations; it would be a capital plan to set them at photo-diaphanig; they would soon discover their mistake. By the bye, that reminds me that if, when the film is dry, you find it is not exactly in the position required, the best means to remove it are to place the article whereon it is in a vessel containing warm water (about 120°), and allow it to remain till it separates, when it may be caught again.

I have found the addition of a little alcohol to the nitrate bath to be of great service in many ways.

Some persons, upon reading these remarks, will, I dare say, exclaim that I have wasted a good deal of your valuable space upon trifling details, that every one, with any common sense, might find out for himself. My excuse, if any be required, is this—that it ought to be the endeavour of every photographer to save his brethren, who are about to try a new process, from failure, by describing the most trivial points of danger, as nothing is more disheartening to the novice than to find everything go right up to a certain point, and then a failure to occur from circumstances which the originators of the process have thought too unimportant to mention.

Many valuable formulæ have, doubtless, been discarded from failure in the first instance, when, if more minute directions had been given, the primary success would have encouraged in any subsequent mishaps.—I am, dear Sir, yours truly,

H. COOPER, Jun.

5, Aberdeen Park, October 12, 1863.

MICROSCOPIC CAMERA.

SIR,—I was prevented noticing Mr. Eden's letter in reply. He admits, clearly, that Mr. Potter first made the instrument he claims as his patent, but adds, that with it I could not produce good pictures—meaning to convey the impression that the instrument was not right for the purpose. The fact is, the instrument *did* answer admirably, and so long as the collodion I obtained from Mr. Willis was right,

I did take good pictures with the greatest ease, and many of them too; but my collodion got wrong, by some means which I could never discover or explain, and then, only, did I meet with difficulty—not in taking them, but in producing a fine deposit of silver, so as not to look coarse under the microscope; and not being sufficiently well versed in photography, nor caring very much about it, I gave up, after several attempts.

I have a recent letter in my possession, from Mr. Willis, in which he tells me, that the addition of the mirror and dark frame was suggested to Mr. Eden by himself, when in York.

Apologising for thus troubling you with this, my final communication on the subject, I remain, Sir, yours truly,
Manchester, Oct. 12, 1863. J. CASARTELLI.

Photographic Notes and Queries.

GOLD TONING.

SIR,—Constantly reading about, and frequently experiencing difficulties in the way of uniform results in connection with, gold toning, it occurred to us that any remarks concerning experiments in that direction might be acceptable to many of your numerous readers. We have therefore inflicted this short letter upon you, not to advance anything new, but to give our opinion of one or two methods of toning which have lately appeared in the NEWS.

When we read of the tones produced by Parkinson's method, we tried it, and found it a great improvement on the old bicarbonate of soda and gold process; there was *no greater* tendency to meadiness, quite as much certainty in action, and much more beautiful results; yet we were not quite satisfied with it, as two baths prepared by the same formula and of the same age frequently did not work alike, resulting principally, I should imagine, from difference in the quality of the chlorido of lime. The formula I here allude to is,—

Chloride of lime	45 grains
Carbonate of lime	75 "
Chloride of gold	15 "
Water	6 pints

used about a week old.

In No. 262 of the current Vol. of the NEWS, however, Mr. Parkinson gave us another formula, in which acetate of soda plays an important part. We have tried it and *are quite in love with it*; we have never had one failure, the tones are all we desire, the bath keeps well and is very economical. I enclose a print toned by this process; please give your opinion of it.—We are, Sir, yours faithfully, BELL & FREEMAN.

P.S.—On Monday last—that is, the day preceding the night on [which] shocks of an earthquake seem to have been felt, more or less, all over England—during the early part of the afternoon, while there was apparently plenty of light, it was almost entirely deficient in *chemical rays*, as six or eight times the ordinary exposure *did not* suffice for a portrait.

Photographic Dépôt, Newcastle, Staffordshire.

October 8th, 1863.

[The print is very good.—Ed.]

ROUGHING THE EDGES OF GLASS.

DEAR SIR,—Several suggestions have appeared, from time to time, as to the mode of roughening the edges of glasses, but the plan I have had in use for some years past is, in my humble opinion, superior to any of them; and with the idea that it may be acceptable to some of your readers, I send you an account of it.

The material I use is corundum, and in the form of a corundum file. Before proceeding, I must, out of consideration to you, as it holds no relation to the editorial file, explain the meaning of this technical term, otherwise I should bring down upon you an avalanche of letters, each containing the pertinent inquiry, "What is a corundum file?"

Of corundum it is sufficient to say that it is a mineral spar, of great hardness and cutting quality, which, when mixed with melted shellac, or some such cement, and moulded on to a slip of iron, which serves as a core to the paste, constitutes the corundum file used by dentists, and sold at the dental dépôts.

I have extemporized a similar tool for photographic purposes, by cementing to a slip of glass, bits of waste corundum wheels,

which is the same compound in the form of a grindstone. As, however, few photographers have the chance of making such a thing for themselves, I have no doubt there would be a good sale for an article of this kind, if some of the dealers would bring it into the market. I would suggest a piece of sheet iron or glass, four inches long, and one inch, or so, wide, coated on both sides with the composition to a thickness corresponding to the width of the surface required to be ground, say $\frac{1}{4}$ th of an inch. The manner of using it will, I think, be obvious; the slip, moistened with water, being applied to the edge of the glass, which may conveniently be placed in a glass-cleaning vice, with the edge projecting, by a horizontal motion, the edge of the corundum grinds the surface of the glass; the core, serving as a guide at the same time, just taking off the cutting edges.—Yours, truly,
GEO. S. PENNY.

[We have used corundum, for the purpose mentioned, with great success, and we fancy we have seen it in the shops of some of the dealers. It deserves to be better known.—ED.]

Talk in the Studio.

THE EARTHQUAKE.—The records at the Observatory, at Greenwich, are thus stated:—"At 23 minutes past 3 o'clock, on Tuesday morning, a slight shock of an earthquake was felt. One of the Astronomical Assistants was observing a fixed collimator, and saw the mark apparently descend through an angle of less than a quarter of a minute of arc, and rise again after a few seconds of time to its former position. No trace of the earthquake was left on the photographic records of the self-registering magnetometers."

ROYAL PHOTOGRAPHS.—The Princess of Wales, the Princess Christian of Denmark, and Princess Dagmar, attended by the Hon. Mrs. W. Grey, again honoured the Messrs. Southwell, in Baker Street, with a visit, and sat for their photographs, on Tuesday last.

To Correspondents.

* * * Current numbers, or full value, given at this office for Numbers 6, 9, 41, 49, 53, 65, 76, 80, 104, of the PHOTOGRAPHIC NEWS.

YOUNG PHOTOGRAPHERS.—Silvery white tones in glass positives are best obtained by using a developer of protosulphate of iron instead of protosulphate. We have often given the formula, but we repeat it again. Take—
Nitrate of baryta 1 ounce
Nitric acid 2 drachms
Water 16 ounces.

Mix and dissolve, and then add—
Protosulphate of iron 1½ ounce.

Let it stand a few hours and then filter to remove the white precipitate, and the solution is ready for use. 2. The use of a newly-mixed solution of sulphate of iron with insufficient acid, or the presence of organic matter in the bath. 3. We do not quite understand the nature of the defect to which you refer; from your description, it is probably caused by floating scum on the bath. 4. A line across the film most commonly arises from a stoppage whilst immersing the plate. 5. A transparent mark at one end or round the edges arises from the partial drying of the film, leaving the part insensitive because impermeable. 6. An over-exposed picture developed rapidly is less apt to be fogged than an under-exposed picture developed slowly and forced in development; but a properly exposed one will give the best result. 7. To avoid too much light on the hair without making the face dark, use less top-light. 8. When there is a shadow in the upper portion of the background, bring it a little further forward to the light.

W. A. S.—In using a second nitrate bath there is no necessity for washing the plate. See article in our number for August 14th. Re-dipping after exposure, except in a bath in perfectly good condition, is apt to cause fog; it is the condition of the free silver which is of the greatest importance. Boiling down and precipitating are both troublesome methods, and should only be adopted when other methods fail.

CAMERA LUCIDA.—You will find some information relative to the building of glass rooms, in No. 59 of the PHOTOGRAPHIC NEWS; and on the best form and general arrangements in our last year's ALMANAC. Mr. Blanchard's design is in No. 249, and Mr. Rejlander's and Mr. Sutton's in No. 235. The top of a house is preferable, if there be surrounding buildings to cut off the light from the garden; but not otherwise. The proportion of glass depends on circumstances. See the article in our ALMANAC.

NOTICE.—To use nitrate glue, first heat the portions of glass, &c., to be joined, and then apply the glue to a flame to melt it, taking care not to burn it. Or it may be made hot in an iron spoon or larger vessel, and applied with a brush. It is not dissolved like common glue. 2. We believe that Mr. Solomon, Bull Brothers, and others whose names you will find in our advertising columns, will supply the papier mache ornaments for accessories. 3. The addition of alcohol to the developer is simply to make it flow more easily. It does not affect the character of the development at all. It is only necessary where the silver bath has accumulated a large amount of ether and alcohol.

EMBOSSED.—Red spots occurring whilst toning, arise from imperfect action of the toning solution on the parts in question. This imperfect action may arise from many causes, such as excess of albumen at the part, the surface

having been touched with greasy fingers; or from air bubbles forming between the prints immersed. In your case it is probable that this is the cause, as you state that the dish is just the size of the print. The fact that you keep the dish moving in such a case, is not of much use; the prints should be moved, and it is a good plan to keep turning them over. If a spot of imperfect toning is observed to be forming, from a greasy mark on the albumen, the print may be removed and immersed in a 10-grain solution of carbonate of soda for a few minutes, then thoroughly washed and returned to the toning bath, and all will probably go well. If an air bubble have been the cause, sometimes a little friction with the finger on the untuned part will increase the action of the solution at that point, and enable it to overtake the rest. The red spots in printing were most likely from some imperfection in the paper; but there can be no reason for increased tendency to the spots in large pictures more than in small ones, except, of course, the greater area presenting more chances for defect.

D. C.—You can adopt two methods to obtain paper prints from glass positives. You may copy them, and produce printing negatives; or, if they have been sufficiently well exposed, you may convert them into negatives; but in that there is always a slight degree of risk. However, proceed as follows:—Remove the black varnish by friction and turpentine; then, if the white varnish have been what is termed "crystal varnish," remove it by repeated washing with benzole or chloroform; moisten the film, and apply a solution of iodine 1 grain, iodide of potassium 2 grains, water 1 ounce; wash off, and intensify with pyro and silver. If it be a spirit varnish, first moisten with alcohol, and then apply an alcoholic solution of iodine, about 5 grains to the ounce, for a few minutes; wash off with alcohol, and intensify with an alcoholic solution of pyrogallie acid, containing a few drops of an alcoholic solution of nitrate of silver.

AMATEUR T. L. P.—The stains you describe as occurring at the bottom of your plate most probably arise from the drainings of the plate coming into contact with the wood of the inner frame. Use a piece of clean blotting paper at the bottom of each plate to collect the drainings. 2. The toning bath should be as nearly as possible neutral. The bath turning purple shows that it is decomposed, and has precipitated the gold. This is caused by the addition of carbonate of soda, which should never be used for a bath intended to keep.

W. CASEY.—The spots have been caused either by a trace of hyposulphite of soda touching the print before it was fixed, or from a trace of nitrate of silver touching it before all the hypo was removed. It is a stain of decomposed hyposulphite of silver.

P. C. J.—You have still a flat effect, apparently from a light too equally diffused all round the sitter. The pictures appear as if you placed the sitter facing the light, thus making your light a front light, the worst you could use. The vignetting will not do; both figure and background must graduate into white much more imperceptibly. The plan is to cut an aperture in a piece of card of an irregular oval shape. Round the edges of this, gun cotton-wool, and, with your fingers and a pin, pull its edges out so as to graduate the light passing through the fringed edges. This mask may then be laid outside the pressure frame, and, by a little care, will give excellent vignettes.

W. W. S.—A decided improvement. No. 2 is very good indeed. No. 1 is a little hard, and No. 3 a little flat in the face; but all are improvements. The tones are pretty good, but might be richer.

DOUNT.—Corrugated iron answers well, we believe, for the opaque parts of glass houses; how far it will answer for the sashes, we cannot say. Iron has one disadvantage, that it presents us little facility for fastening curtains, drapery, &c., inside. We believe the iron roof answers, but we have no certain means of knowing.

SCOR.—Theoretically, it is better to focus with the aperture you are going to use, as, with some lenses, the focus is thrown a little back when a small stop is put in. But if the stop make it too dark to focus conveniently, use an aperture sufficiently large for convenience in focussing, and then change. With a good lens very little difference is made in the position of the focus by the stop.

J. GILBERT.—Mr. Williams has given up publishing stereoscopic slides for many years. We think it is probable that the last stereos of Warwick Castle and neighbourhood are by Mr. Bedford, published by Messrs. Catherall and Pritchard, Chester. We cannot tell you how many sheets of paper 20 ounces of albumen will coat. The albumen, of course, gets gradually thicker from evaporation, and each sheet will vary very slightly. The keeping qualities of albumen vary with temperature and other circumstances. Nothing is better than pure albumen for giving a good surface. Float the paper, and remove as quickly as possible. We believe albumenizing twice will give a higher surface, but increases danger of streaks.

DELL PHOTOGRAPHY.—When you add acetic acid to an alkaline bath, you form acetate of silver, and this is frequently a source of streaks, spots, &c. You should have commenced by adding the carbonate of soda, then sunning and filtering, and finally adding a trace of nitric acid. It is now a difficult matter to get rid of the acetate of silver.

J. A. B.—Where the blisters disappear on drying, we do not think that any danger to the print need be apprehended. It is, however, important to wash well, so that no trace of the hypo may be retained in the vesicles formed by the blisters.

A. BROTHERS.—No photograph has arrived by post, or otherwise.
MERLIN—Shall be considered. You had better give us a Post-office address. Several letters and articles are compelled to stand over.
Several Correspondents in our next.

Photographs Registered during the Past Week.

MR. WM. MAYLAND, Huntingdon College, Cambridge,
Two Photographs of Mr. Thomas Hayward,
Four Photographs of Mr. R. Carpenter.
MR. JOHN KEENS, Newall's Buildings, Market Street, Manchester,
Photograph of the Rev. Father Richardson.
MR. JOHN JAMES WILSON, 2, Cleveland Villas, Surbiton, Surrey,
Photograph of the late Dr. Roots.
MR. THOMAS TYLEY, 23, Trinity Street, Bristol,
Photograph of a Monument to the Memory of John Joshua,
Lord Proby.
Photograph of a Monument to the Memory of the Rev. Thomas Winter.

THE PHOTOGRAPHIC NEWS.

Vol. VII. No. 268.—October 23, 1863.

CONTENTS.

	PAGE
A Rapid Dry Process	505
The Photographic Exchange Club	506
A Costly Lens	507
Scientific Gossip	508
A Dozen Brief Hints to Portraitists	509
Jottings from the Note-Book of a "Photographer's Assistant," No. IV.	510
The Triple Achromatic Lens. By J. H. Dallmeyer	511
Proto-Acetate of Iron as a Developing Agent. By M. Me. A. Gaudin	512

	PAGE
One of the Causes of Pin-holes in Negatives. By J. W. Swan... ..	512
A Lesson in Photography.—No. 16.—Tannin Process	513
To Prevent Paper from Turning Red	514
Correspondence—Photodiaphanie.....	515
Photographic Notes and Queries—The Use of a Lens in Print- ing—Substitution for Yellow Glass	515
Talk in the Studio	515
To Correspondents	516
Photographs Registered during the past Week	516

A RAPID DRY PROCESS.

WE have recently had an opportunity of trying some dry plates of extraordinary sensitiveness and general excellence. We have tried two entirely different samples, by different processes and different persons, and both possess unusually good qualities. One lot was prepared by Mr. Bartholomew by a process which we give below; the other by Mr. Hurst, of Mirfield, prepared by a process which we hope to publish, shortly. The latter gentleman called upon us a few weeks ago, and favoured us with a sight of some exquisitely fine stereo negatives, all taken with very rapid exposures, some possessing good clouds. He left a few of his prepared plates for our own testing, and promised, when he had quite satisfied himself as to the very best conditions, to give us further details.

About the same time we received a note from our correspondent, Mr. Bartholomew, which excited our interest. It ran as follows:—

I have been using some dry plates of great sensitiveness lately, and I am sure they completely overthrow Mr. Sutton's froe nitrate principle, for they are thoroughly and completely washed, and require about ten seconds' exposure for an open sunlit view, at 10 A.M. this month, Dallmeyer's No. 1 triple lens, stop No. 2. If you can find any spare time to try a few $4\frac{1}{2} \times 3\frac{1}{2}$, may I send some? *I guarantee success!* Cold pyrogallie development, and no bother about a moveable film (under reasonable treatment). Many of the recent tannin modifications are very good, but here is a formula far easier of preparation, far more sensitive, and, I think, producing unsurpassed negatives.

We subsequently received two or three other communications from Mr. Bartholomew, all of them speaking of confirmatory evidence as to the rapidity and excellence of the process, and explaining that it was simply a modification of the alkaline process he had proposed nearly two years ago. We prefer to state the matter in his own words, and subjoin, therefore, the following letter:—

DEAR SIR,—Your correspondent, "Delta," calls attention to my alkaline-gelatine process, as involving the principle of alkaline development, which it certainly does, if plain pyro and water is used to commence development. Curiously enough, his remarks have appeared just at the time when I have completed some trials of dry plates prepared by a plan I have long proposed to myself, but hitherto forborne carrying out; in fact, I have shelved this alkaline process, and devoted more attention to the simply washed and dried film formula until now: the present time, then, appears to me rather apropos to say a few words on the matter. Well, these plates are with me the most sensitive dry films I have prepared, and stains, &c., are not present, I may say, in more than their fair proportion, being nearly absent altogether.

I am afraid to speak of the exposure required, but will give a faithful *resumé* of the time of one plate as a guide; ten days ago (about), $9\frac{3}{4}$ A.M., $7\frac{1}{2} \times 5$ plate, No. 1 triple lens, No. 2 stop, sunlit view of church, 15 seconds, cold pyro and water development, followed by the usual silver and acid addition to intensify; this negative was visible directly on the application of the

pyro and water, and was completed in intensity in less than five minutes; sky printing through, and foreground corners vigorously brought out, thus evidently verging on over-exposure.

I hope any prejudice existing to part of the formula may be laid aside, and a fair trial be made of it; after the manner of Mr. Sutton, allow me to recommend a trial of *my* process, which is to coat and sensitize a plate in my morphine bath, wash as in the tannin process, drain a little, and coat with a solution of—

Gelatine	5 or more grains
Water... ..	1 ounce
Bicarbonate soda	$0\frac{1}{2}$ grain

dissolved by heat and filter, then apply hot to the plate; wipe the back and place to dry evenly, as usual; develop with pyro and water, and intensify with pyro, acid, and silver, as usual.

I do not state positively a morphine bath is indispensable, not having compared results, except from memory; but I am led to believe that the sensitiveness *is* greater from these new trials.—Yours faithfully,

WM. BARTHOLOMEW.

Egham, October 5th 1863.

We received from Mr. Bartholomew a box of plates, which, on the first convenient occasion, we exposed and developed. How long they had been prepared we cannot tell; but they had been in our possession nine days. The light was unfortunately very poor, without direct sunlight, and a somewhat hazy atmosphere. We used a Dallmeyer's No. 1 B lens, with various stops, and for the first exposure gave about double the time we should have judged necessary for a good wet plate with iron development. The plate was a little over-exposed. Sundry other exposures eventually decided us that about one-half longer than for wet collodion gave us the best results. With the lens in question, of about six inches focus, and a stop of half an inch, we got a good negative with an exposure of fifteen seconds, in a dull, diffused light, the subject a portrait and foliage.

In development we proceeded as follows:—Having first moistened the film with common New River water, we then applied a three-grain solution of pyrogallie acid, with acid of silver: very rapidly an image appeared, distinct and red by reflected light, but feeble and phantom-like when examined by transmitted light. In the course of about a minute, all the detail being well out, we added a few drops of a solution, containing ten grains of citric acid and ten grains of nitrate of silver to an ounce of water. The required intensity was now easily and quickly attained; the whole process of development occupying little more time than would have been required for a wet plate. The deposit was of an extremely non-actinic colour, resembling a collodio-albumen plate, with the general tint by reflected light of a good pyrogallie acid negative. In some cases where the plates were not handled with sufficient care, there was a slight tendency to loosening and wrinkling of the film; but, with care, this was avoided, and there was no danger in any case of losing a film. Altogether, our experiments with the plates were decidedly satisfactory.

Mr. Bartholomew, in a subsequent letter, states that the collodion he uses contains a full proportion of a bromide, but does not state how much. He states his conviction, also, that a little sugar or honey added to the gelatine solution would probably both add to the sensitiveness of the plates, and prevent any tendency to wrinkling and loosening of the film.

Mr. Hurst's plates are produced by a modification of the tannin process, the nature of which we do not know. They present several features quite distinct from those of Mr. Bartholomew. The latter, when wet, are more transparent than when dry. Those of Mr. Hurst, when moistened, become more opaque and creamy; and in this respect resemble those of Dr. Hill Norris. They are scarcely quite so sensitive in our hands as those we have noticed above; but they were extremely rapid, and behaved exceedingly well in development. They appeared to require an exposure of about twice that of ordinary wet collodion. They received the same treatment in development as the others, and rapidly gave clean, bright, satisfactory negatives, without the slightest tendency to losing or moving. With a pair of Dallmeyer's stereo lenses, and a stop of three-eighths of an inch an exposure of forty seconds gave us a good negative in a dull light. Some of Mr. Hurst's quasi-instantaneous exposures in a good light gave good negatives. We shall look with much interest for further information regarding them.

Before quitting the subject, we have another reclamation to make on behalf of Mr. Bartholomew. In the last number of the *Photographic Notes*, Mr. Sutton refers to a "new rapid dry process, the discovery of the well-known amateur Mr. Thomas Fothergill," which yielded, in the hands of a gentleman in Jersey, results equal in rapidity and quality to wet collodion. Mr. Fothergill's letter referring to the subject, does not, however, claim any discovery, but states that he has "adopted the valuable suggestion made by Mr. Hannaford, two years since, of pouring the albuminate of silver over the plate instead of relying on the production of that substance in the body of the collodion as formerly," referring to the plan adopted in the old Fothergill process. The method now adopted was first suggested by Mr. Bartholomew, in February, 1861, in a letter in our pages; and we received from him a negative by the process. We then expressed a doubt on the keeping qualities, as Mr. Sutton now does. Mr. Hannaford, a few months afterwards, quite independently, we believe, having overlooked the letter in question, made a similar suggestion at the South London Photographic Society. We at that time accredited Mr. Bartholomew with the original suggestion; and now, whilst we esteem the labours of Mr. Hannaford very highly, and have considerable regard for him as a personal friend, we feel it to be simple justice to Mr. Bartholomew that his priority should be acknowledged.

THE PHOTOGRAPHIC EXCHANGE CLUB.

The Exchange Club, established nearly five years ago by the conductors of this journal, under the title of the Stereo Exchange Club, and subsequently, under modified conditions, as the Photographic Exchange Club, has, during that time, been carried on with varying success and satisfaction. The system of exchange, originally proposed and carried out, was on this wise:—Photographers wishing to possess the stereoscopic pictures of others in exchange for their own, were invited to forward specimens of their work to the Editor of this journal for his approval as fair materials for exchange. At convenient intervals, a list of the names and addresses of those whose productions were considered satisfactory was published in our columns, and members then exchanged with each other, either with or without correspondence. It was customary to send one experimental print to each gentleman whose name was published, in order to ascertain the quality of the returns which might be expected, and then the exchanges were extended further between those

whose productions pleased each other. This system worked very well for a time; but complaints every now and then reached us of very inferior returns being sent for good prints.

This led eventually to a change. It was agreed that a secretary should be appointed, who, assisted by a couple of referees, should conduct the exchanges. All prints were to be forwarded to Mr. Howard, who volunteered to undertake the somewhat onerous duties of Secretary, and it was arranged that his judgment, and that of the referees, were to be the final standard of appeal in deciding the relative worth of the pictures, stereoscopic and others, sent for exchange. An equitable apportionment was to be made; and where prints absolutely worthless were sent in, they were to be returned to the sender. For a time this promised well; but has gradually, from a variety of causes, all of which we cannot even guess, becoming less satisfactory in its operation. A large number of very poor prints have been sent in, and frequently such as were absolutely worthless. Thus the Secretary's honorary duties have become irksome, and without sufficient satisfaction in the result to others to induce him longer to continue them. Mr. Howard has, therefore, resigned the office of Secretary, which, for two years, he has so well filled. We regret the issue, and we regret its cause. We can only express our own sense of the indebtedness of every member of the Club to him for the ungrudging expenditure of time, labour, and money in their behalf, for it was impossible to fill such an office without being occasionally out of pocket, as well as heavily taxed in time. We append the letter we have received announcing his intention:

DEAR SIR,—I have to inform you of my intention to relinquish the position of Secretary to the Photographic Exchange Club. The difficulty of successfully managing the exchanges so as to avoid the invidious position in which I feel myself, together with the lack of support, alluded to in my last letter, has induced me to take this step, which I shall feel obliged if you will announce in the NEWS.

I would suggest that the Club be started afresh, as before October, 1861, viz., by gentlemen forwarding their names and addresses to you, simply adding to the old rules the privilege of declining a proffered exchange, should a member be dissatisfied with the sample sent.—I am, dear sir, yours truly,

F. HOWARD.

10, Lansdowne Road North, South Lambeth,
October 16th, 1863.

We have also received several letters from members of the Club regretting the probable termination of the exchange system, and making suggestions. We select a couple for publication:—

DEAR SIR,—I have been for some time a member of the Photographic Exchange Club, and am highly satisfied with the manner in which Mr. Howard, the Secretary, and the Committee have performed their duties; and, therefore, it is with great regret that I received a letter from Mr. Howard this morning, in which he stated "that he had determined to relinquish the office of Secretary." After having read the letter from him that you published a few weeks ago, I cannot wonder at the decision that he has come to, as it must be very discouraging to a lover of the art to see the standard deteriorating instead of improving steadily, as it ought to do. I have no doubt this arises, not from the original members becoming less expert, but from many of them ceasing to contribute, and their places being filled by others who are probably beginners in the art.

I should be very sorry, indeed, if the Club should entirely pass out of existence, as, by its means, hundreds of beautiful pictures have been distributed, which might probably otherwise never have been seen by any photographers but those who produced them. I therefore appeal to you, and through you to photographers who take an interest in something besides portraiture, to make some effort to continue the working of the Club.

I will not suggest the appointment of new officers, as I believe the failure of the Club is not in the slightest degree owing to any omission or fault on the part of the present Secretary or Committee; but rather owing to a slackening in the zeal of the members, which may partially have been caused by

the Club having been carried on through the summer months, when many, especially professional photographers, have their time too fully occupied to make exchanges. I would, therefore, suggest that in futuro it shall be discontinued during the *summer months* (say from April to September), in order that it may commence with fresh vigour after lying dormant for a while.

If you, or any of your influential readers, cannot organize any new scheme likely to succeed, let us go back to the old system as it was before 1861, and take our chance of receiving bad exchanges rather than have none at all. I shall be glad to co-operate in any scheme you may suggest for the continuance of the Club.

I have sent you a few of my stereos by book post, and shall be glad to hear your opinion of them.—I remain, yours respectfully,

J. P. GIBSON.

Hexham, October 17, 1863.

SIR,—I regret to find that Mr. Howard is obliged to relinquish the office of Secretary to the Exchange Club, as it is perfectly clear that under those circumstances the Club (to use an Americanism) will go under and be wiped out. Surely, the members of the Club will make an effort to avert this ending of what must have been a source of some pleasure to all who have sent prints for exchange, and even those unfortunates, whose prints were sent back, must admit that Mr. Howard's courtesy and kindness softened the disappointment, and encouraged them to try again and do better next time.

I cannot but think that the members of the Club only require to know the fact that it depends solely upon themselves whether the Club lives or dies, to make them come forward now, as they did when it was commenced, and revive it.

I think it such a pity that it should fall to pieces when it was working so well as it has been doing. It cannot be that all the members have used up all their negatives, there must be some that have not been exchanged: if they would only set to work and take advantage of the first fine day to print off a batch, I hope Mr. Howard would be persuaded to resume his office.

I agree with what you said, a week or so back, that it enhances the pleasure of taking a fine view much, to know that you will be able to obtain others, in exchange, of places you may never be able to visit.

Apologizing for so long a letter, I remain, Sir, yours, &c.,

ONE OF THE CLUB.

London, Oct. 17th, 1863.

For our own part, we shall readily give effect, so far as we can, to any decision at which the members may arrive. It is possible that a recurrence to the old system, without confining its operations to stereographs, may be found most satisfactory. We leave the subject in the hands of those concerned, without further comment at present, merely inviting those who have plans to suggest to communicate them for consideration.

A COSTLY LENS.

WE have just received a letter from Mr. J. W. Osborne, who is in Berlin, carrying out, in conjunction with one of the first European lithographers, some important experiments and works in photolithography, some further particulars in regard to which we hope to publish shortly. Amongst other interesting photographic items, he informs us that he has just secured from the Melbourne Government instructions to order from Mr. Dallmeyer, to be used in the copying of maps to be photolithographed, a lens which shall cost £250. As this is an unprecedentedly large sum for a photographic lens, a short history of the matter may be interesting to our readers.

Some two or three years ago, Mr. Hardwich received from Mr. Osborne, the Photographer to the Melbourne Government, a letter, asking him to undertake an examination of some of the new lenses recently introduced to photographers, with a view to sending him one of the most perfect. The issue was, the purchase of a No. 6 Triple Achromatic, which was accordingly sent, and has given the fullest satisfaction. But Mr. Osborne, whose keen judgment and enterprising

spirit is ever looking to a higher perfection, conceived the idea of a lens ground on principles which had not hitherto been attempted for photographic purposes on account of its costliness and unnecessary refinement for ordinary use. It may be necessary here to make a brief explanation. In the polishing of photographic lenses, as in many other matters, a compromise is accepted in place of the highest theoretical perfection. The surface of the lens, which looks so smooth and bright to the eye, is really not a perfect continuous surface, without the slightest inequality. If carefully examined with a powerful glass, or by reflection, it is seen that the small hills and hollows (remains of the last stages of the grinding process) still exist, although sufficiently polished over to give it to the naked eye the appearance of a fine and continuous surface. In the common cheap lenses this surface is often very imperfect indeed; whilst in the lenses of the best makers the most perfect surface to be obtained by the means available is secured; and the difference in result between this and that of the common lenses is often apparent to the naked eye. For most photographic purposes the result thus obtained by good makers is all-sufficient. There is, however, a method of obtaining a still more perfect surface, but at a great cost of means and labour. The method in question is used for grinding and polishing the object glasses of the best larger telescopes, in which the high magnifying power employed renders apparent the most insignificant imperfection of the surface. In these lenses the time required for each surface is always weeks, so that a triple lens so ground and polished, having twelve surfaces, would probably require months to complete the glasses, during the whole of which time machinery would require to be kept in action, and the continued close attention of the most skilled optician directed to watching and governing the result. By this method a perfectly equal continuous spherical surface is obtained, and with the highest possible polish.

For ordinary photographic purposes, such a lens would be as unnecessary as it would be necessarily costly; indeed, we do not imagine that anything would be gained by it. But Mr. Osborne conceives that for copying maps, &c., for photolithography in which the most perfect delineation of the finest lines becomes a matter most vital to the highest success, the value of such a lens becomes a consideration of no light import. He accordingly laid the question fully before his Department with all the arguments belonging to the case. The issue is, that he has received an official communication from Mr. Ligar, the Surveyor-General, informing him that the matter had been duly considered by the Minister, that it had received approval, and he was instructed to place the matter at once in the hands of Mr. Dallmeyer, with whom he (Mr. Osborne) had fully discussed the matter when he was in England.

"The most perfect definition," Mr. Osborne writes, "is, I conceive, a fundamental condition necessary for photolithographic work, for without this it is impossible to compete with the draftsmen on stone, and that definition I hope to get with a lens, ground and polished, and the astronomical method." After asking our personal aid in occasional superintendence of the matter during his absence on the continent, Mr. Osborne adds: "I have great faith in Dallmeyer, and I am sure he will exert himself to the utmost; and, as far as form is concerned, I leave the matter entirely in his hands. The experiment is altogether an exceptional one, but I hold that such exceptional experiments should be tried by public departments; and, in the present case, I think some credit is due to the Melbourne Survey Office, and its head, Mr. Ligar, for showing the way in this matter."

We cordially agree with Mr. Osborne in this view of the case. And as part of the heavy cost will arise from the necessity of constructing new tools for the especial case, if the experiment should prove as great a success as it ought, the photographic public will gain, not merely in the demonstration of an important fact, but in the modified future price, rendered possible by the present liberality and enterprise of the Melbourne Government.

Scientific Gossip.

PHOTOMETRIC VALUE OF THE ELECTRIC LIGHT—THE CHEMISTRY OF PAINTING—DISCOVERY OF ROCK SALT.

THE electric light has often been referred to in these pages, and photographers must be well aware that it is the most powerful source of artificial light which we possess, and also the one richest in chemical rays, exceeding in this respect the sun itself. Some doubt has hitherto prevailed respecting the relative intensity of the electric, as compared with ordinary light, owing doubtless, partly to the difficulty experienced in measuring photometrically so brilliant an evolution, and partly, perhaps, to the expensive character of the light, and the consequent somewhat rarity of its production. The only accurate experiment which we can recall at this moment, is by Bunsen, which was made with a battery of forty-eight carbon cells, in which he estimated the photometric equivalent of the light at 572 candles. An opportunity has been recently afforded for Professor W. B. Rogers to make some accurate experiments on this subject, in which the battery consisted of 250 carbon elements, each having an active zinc surface of 85 square inches. These were grouped in five battalions of 50 each, and the light was arranged in an apartment where a range of about fifty feet could be obtained for the photometric apparatus. Instead of an ordinary standard light equivalent to twenty candles, a unit was substituted ten times as great, equivalent therefore to 200 candles.

The photometer was the one known, we believe, as Bunsen's. It consists essentially of two pieces of paper, a circular disc in the centre of each having been touched with oil to increase the transparency. They are placed close together, facing the observer, and reflectors are so arranged at their back that the standard light illuminated one whilst the electric light illuminated the other. The pieces of paper are enclosed at the other end of a dark box, in the front of which is an aperture for the observer's face, a cloth or similar contrivance being placed to keep out all extraneous light. The observer, therefore, sees at a convenient distance in front of him two illuminated discs of paper. By altering the distance between one of the lights and the photometer, the amount of luminosity of either disc can be regulated at will, and owing to the law of the diminution of light in the inverse ratio of the square of its distance from the source, it is not difficult to so adjust the distances, that the discs of paper shall be equally illuminated. This having been effected, it is a matter of simple calculation, to obtain the relative photometric values of the two sources of illumination.

In this experiment, the photometer and standard lamp were fastened at a fixed distance apart, and were arranged to slide on a horizontal graduated bar, extending towards the carbon points of the electric light, and the platform was moved to and fro, until the illumination of the discs was equal. It was found by a series of experiments that the electric light was equivalent to from 52 to 51 times that of the standard light, making it as intense in illuminating power as 10,000 to 12,000 standard sperm candles. This degree of intensity, it must be remembered, is that of the naked light, unaided by a reflector; when the rays are concentrated by a parabolic reflector, the power is enormously increased, its illuminating force being then equivalent to several millions of candles, all pouring forth their light at the same time. Comparing the luminous power with the number of battery cells, it will be seen that in Bunsen's estimate the proportion was nearly twelve candles to the cell, whilst Professor Rogers' estimate is about forty candles to the cell. This difference is no doubt due to the greater intensity of the battery, and the cumulative effect of its arrangement.

Mr. Holman Hunt has suggested to the Royal Academy commission, that there should be a professor of chemistry appointed by that body, who should devote his time to the study and explanation of the properties of colours,

how they affect each other when mixed, what are the values, as regards permanency, &c., of the different new pigments which are so constantly being brought forward, and what new pigments may be safely introduced. The suggestion is one that we would earnestly press on the attention of the commission, as it would tend materially to the advancement of art. Chemistry is constantly giving new and beautiful colours to the artist, and it is capable of informing him of their degree of permanency when exposed either to the chemical action of the atmosphere and its gaseous impurities, or to the fading effect of long exposure to light. This information, indeed, is generally given with every new colour, the introducers being in most cases alive to the advantage of having their own laudations backed by a competent scientific authority; but there is another branch of chemistry in relation to art which is not so frequently studied, owing to the fact that it is no person's particular business to do so, and that is the mutual action of pigments one on the other, and the influence on them of the vehicles in which they are employed. It is a notorious fact that modern paintings do not stand. Those who will notice the paintings in the galleries at South Kensington, and remember what they were some years ago, cannot fail to be struck with the alterations which a few years have made in some of our best pictures. These changes must not be fairly ascribed to the injurious action of light, or the deleterious gases present in the atmosphere, they are more probably the results of the action of pigment upon pigment and of alteration in the vehicles and varnishes employed, and these being mixed with no regard whatever to the chemistry of the various materials it is a wonder that some of them stand as well as they do. The only object of the artist in preparing his palette is to get the required shade in a mixture that will work easily. The old masters, who had none of the modern resources of test tube and precipitating glass, were obliged to content themselves with such mineral colours as were given them by nature: these were consequently of great stability, and were ground in the simplest possible media. Their productions have for the most part stood unaltered, except as regards the mellowing of tone by the darkening of the varnishes employed; but will anyone venture to predict that modern paintings will be equally permanent? The fact is, that brilliancy of colour is principally aimed at, and permanency is lost sight of, except by some few exceptional artists. The preparation of pigments has gradually been withdrawn from the artist's studio to the chemist's laboratory, and as it is not likely that every artist would care about undergoing a course of chemistry as a preparatory initiation into the mysteries of his art, it is a necessity that there should be a properly authorized professor of chemistry whose duty it should be to examine every new claimant for the honours of the palette, and not to admit the colour, however brilliant, unless it has proved to possess the more sterling qualities of stability and innocuousness. We sincerely hope the Academy will adopt Mr. Hunt's suggestion, and elect a Professor of Chemistry, who shall found an art standing in the same relation to painting that pharmacy does to medicine.

Common salt is not so expensive a commodity that a new source is of much importance to photographers; nevertheless, our readers will feel interested in learning that an extensive deposit of rock salt has been discovered at Middlesbro'-on-Tees, under the new red sandstone. It lies about 200 fathoms deep, and has a thickness of about 120 feet. The district is full of chemical works, where common salt is one of their staple articles of consumption, being used as the source of soda. This discovery will, therefore, prove very valuable to this part of England, as it will entirely take the salt trade from Liverpool and the Nantwich mines. Its extent laterally has, of course, not been ascertained; but there is no doubt that it is very extensive, for it is now pretty well understood that rock salt lies in large natural basins, as if the water of a salt lake or sea arm had been evaporated, and the salt left behind.

A DOZEN BRIEF HINTS TO PORTRAITISTS.

I CHANCED to be in a photographic establishment, not many days since, when there came in a portly, well-dressed man, who, in a bustling, business-like way, enquired if any back grounds were wanted? Receiving encouragement, he brought in from his chaise, at the door, a roll of "slips" and a roll of backgrounds, and proceeded to display them, one after the other, with many eulogistic remarks on their respective merits and beauties. The proprietor purchased two of the "slips," and when the vendor had departed, inquired of me if they were not "first-rate," to which question I evaded giving a direct reply.

Now, the price at which these were sold set me a-thinking. I guessed, from the appearance of the vendor, that he must secure the lion's share of the profit upon such goods, but I knew that even this share must render a very brisk trade necessary to make such sales as he effected sufficiently remunerative. Putting down his share, then, at the lowest possible figure in connection with what I considered the brisk trade aforesaid, and adding to this the cost of material procured in the cheapest market, I found that the unfortunate painters of such slips and backgrounds must be labouring very hard to earn enough to provide each one person with the commonest necessaries of life, in life's most poverty-stricken aspect.

From the vendor and producers my thoughts turned to the purchaser. He was a photographer holding a respectable position in his profession, and ambitious, to use his own words, of "turning out nothing not first-rate." His glass-room was fitted up with all the best approved appliances, his operator was a very skilful, well-paid gentleman, he carefully overlooked every print sent out from his establishment, and his lenses were chosen, not for their cheapness, but for their excellence.

These lenses brought me to the point I wish here to briefly dwell upon. The grand virtue of a good lens is to render natural objects on the sensitized plate with the truth they possess when thrown upon the retina of the eye. a lens which distorts or gives unfaithful images being speedily rejected by any gentleman who wishes his pictures to be *in good drawing*, as an artist would say.

And yet here was a gentleman anxious to produce, or "turn out nothing not first-rate," and increasing the expenses of conducting his business very materially in carrying out such a view, purchasing, for introduction into his pictures, such ludicrous specimens of distortion and unfaithfulness, or, in other words, bad drawing, as the very worst lens of the very worst maker could not possibly equal.

Then comes the thought what a great number of photographers there must be acting in this singularly inconsistent way if these vendors of cheap backgrounds, slips, &c., can succeed in making their business at all a paying one: and I am assured, on the very best of authority, that such itinerant dealers abound all over the country, as well as in London, and really drive a very brisk and profitable trade.

Under these circumstances I thought a few hints to portraitists on the subject of backgrounds would not, just now, come amiss.

1st. Pictorial backgrounds should be drawn in correct perspective according to the position of the lens in regard to the sitter, or model.

2nd. It should be so managed as to give an effect of space behind the sitter, in order to relieve and throw forward the head and figure, and render the portrait the most prominent thing in the picture.

3rd. It should contain neither white nor black, nor anything approximating thereto, because, while white would destroy the prominence of the lighter portions of the head by coming forward with the same degree of power; black would destroy the force of the shadows in the head and figure, and so tend to weaken the effect of relief.

4th. It should be so contrived as to have its darker portions on that side against which the lighted side of the face

comes, and its lighter portions on that side which relieves the shadowed side, because the contrast thus obtained gives brilliancy to the lights and force to the shadows in a manner far more legitimate and effective than that of slightly under-exposing, and so losing half-tints in the shadows, or that of seeking the extreme of brilliancy by chemical and manipulative means.

5th. In a landscape background a little violation of truth is *perhaps* permissible; we have, at any rate, precedent for it in the best works of our greatest portrait painters. As an instance, I will mention the low position usually assigned to the horizontal line or line of the horizon. As most people know, the height of this line indicates the height of the spectator's eyes, and consequently regulates the general effect of every object in the picture. If you place yourself before a window commanding a view of the horizon, you may readily convince yourself of this, supposing you to be ignorant of the fact. Sit or kneel and mark on the glass the height of the horizon. Then rise, and the horizon rises with you, still retaining the level of your eyes. In the case of a photograph, of course, the spectator is represented by the camera and the height of the horizon, to which every line converging from the said spectator ascends or descends, is, or should, to be strictly correct, be the same as that of the camera. But the air of majesty and consequence given to a figure when the line of the horizon is kept low, is supposed to justify a violation of truth in this respect. As to the legitimacy and propriety of such a plan, and when or under what circumstances it is to be used, therein must a man be his own judge. I need only say that the ablest and greatest masters in art have not hesitated to adopt it when their subject seemed to require such treatment.

6th. In an interior, consisting, as it largely does, of lines, care should be taken to compose these lines well with the figure. You must remember that a point catches the eye without retaining its glance, while a line carries the eye along its whole length, and if these lines are so artfully designed as to carry the glance of the spectator, wherever it may chance to fall, back from every quarter to the prominent or most important object in your picture, viz., the head, these lines then do their duty. They have, at any rate, no right to take the eye *out* of the picture.

7th. When you use your background, placed at some distance from the sitter, or take your picture with a short focussed lens, have the lines in it painted much finer, and rather stronger than would otherwise be necessary, and for this reason: lines out of focus are thickened and weakened. The same rule applies to the general effect to be got in backgrounds thus used; that is to say, allowance should be made for the blurring, thickening, and weakening of every touch applied in the painting thereof.

8th. Let the painter of your background see a picture taken in your glass room, and fairly representative of your work, so that he may adapt the character of his work to the character of your work. If you use a thin negative, having but little intensity, the contrasts of light and shade in the background may be tolerably powerful; but if you use an intense negative there cannot be too little contrast in the painted background. I have seen a background used by two different operators assume two strikingly contrasting appearances. In the thin negative it was perfect—soft, quiet, harmonious, and subordinate; while in the intense negative it was hard, staring, and presumptuous. The same process that had destroyed the delicate half-tints of the face, and converted them into staring patches of white paper, having also taken out the more tender tints of the landscape, and put bold white in the place of modest grey.

9th. Have your backgrounds painted in black and white, rather than in colours or browns. The argument against colours in backgrounds needs no urging, being generally understood. And yet blue skies, and violet castles, and green trees are still to be seen in these productions, one manufacturer, who boasts a large business, invariably using colours, because, as he says, they "look prettier, and sell better." The

use of brown certainly gives a less sombre and gloomy effect to the background, when in the glass studio, and has a nice, warm, cheerful effect, but argument against their use is here in a nutshell. The brown is warm, or, in other words, contains red, and so, where the colour is used thin, and where the colour is used thick, presents not only a contrast of light and dark visible to the eye, but a contrast of chemical action only visible in their action on the sensitized plate.

10th. When you use a landscape background, adopt the plan first introduced, I believe, by Mr. Wall, some years ago, viz., that of having the lower part of the background long enough to be stretched upon the floor of the room, and painted in imitation of earth, &c., so as to blend with, and seem part of, the background itself. Some very excellent effects have been got in this way far surpassing that of a piece of plain floor-cloth, or the sweeping of a quantity of gravel and straw about the feet of the model.

11th. Is, oh! most heterodox! for it says, avoid those scrupulously clean, neat, smooth, spotlessly flat backgrounds, which are so destructive of relief, and space, and breadth, and artistic effect, which give the figure an appearance of being inlaid, and have been avoided in all real works of art ever since the middle ages. A graduated background, or a background having its own lights and shades, and indicative of some amount of atmosphere or distance between it and the portraits, is the right and proper thing, not a clean newly-painted wall one or two feet from the head.

12th. If you desire the background to look real, and as if taken at the same time with the figure from nature, it must not only be well and skilfully painted, but the point of sight, or, strictly speaking, the vanishing point, to which all the high and low lines converge, should be exactly opposite the point of view represented in the position occupied by your camera. The light on the figure and the light on the background must also be the same. So ends my dozen hints on backgrounds. R. A. S.

JOTTINGS FROM THE NOTE-BOOK OF A "PHOTOGRAPHER'S ASSISTANT."

No. IV.

THEORY OF THE ACTION OF LIGHT.—TIME OF EXPOSURE.

DURING the summer of 1862, a suggestion thrown out by Mr. George Price, in one of his ably-written papers, induced us to undertake a series of experiments in order to trace out the agents employed in the production of the image on the surface of albumenized paper. From the results of these experiments (which in a future jotting will be given in detail) we were drawn almost against our will to the conclusion that during the process of sensitizing, although the silver enters freely into combination with the albumen, the union between the metal and the chloride salts is not to any perceptible extent determined until exposure to the electric influence of the actinic rays. We are aware this newly-pounded doctrine will be regarded by many as a photographic heresy, but let it be remembered that the chloride salts, as associated with dried albumen, exist in a crystalline form, and no union can be effected with the silver, under the conditions present in sensitizing operations, until the above-named salts have yielded to the solvent action of the liquid. In plain salted papers this power is easily brought to bear on the substance named, because the unguarded interstices offer no obstruction to the admission of the fluid; but with an albumen surface the conditions alter, and the solvent agent is unable to act upon a tithe of the salts incorporated with the albumen. A minute portion of the chloride of silver is, we admit, formed on the immediate surface of the albumen during the time of floating, but the quantity is so small that its presence cannot be detected when the paper is submitted to a thorough washing in distilled water, previous to exposure to light; although, under the conditions described, the albuminate remains as sensitive

as a surface of the same substance, prepared free from chlorides, and exposed to light without washing. Now, if in the first-named experiment chloride of silver was present, its modifying influence in colour and sensitiveness would immediately lead to its detection; but if, on the other hand, the salt was dissolved out during the process of washing, it being an insoluble salt, its separated existence would speedily be proved.

It is generally admitted that the albuminate of silver forms the staple part of the picture, as, doubtless, it does so, because its production is unobstructed by accidental causes; but, at the same time, without the pressure of a more sensitive agent, printing operations would be a tedious and altogether unsatisfactory affair. We have now to inquire how the union between the silver and the chloride salt is effected, if not so during the process of sensitizing. Every person who has had anything like experience in photographic printing must have observed the additional vigour and sensitiveness gained by the presence of a small amount of moisture in his paper. It must be admitted this dampness would assist materially any process of decomposition that may be going on; and as moisture is a good electric conductor, we believe the union is effected by the decomposing agency of the last-named power, whose action is set up directly the paper is exposed to the light, and by this action the chlorine is separated from its base, its strong affinity for silver causes it to seize upon the free nitrate, and a second decomposition ensues; hence the necessity for a portion of the last-named salt remaining in a free condition on the surface of the paper. To prove that a union such as we have described is brought about by the agency of actinism, is possible: it is only necessary to place into close contact a portion of nitrate of silver with one of the chloride salts, on exposure to light decomposition such as we have described immediately commences.

An objection may here be urged, which, at first sight, would appear reasonable, viz.: If the combination between the chlorine and metal is effected by light, how is it to be explained, that the stronger the power exercised by the sun's rays the redder the picture produced, when it is well known that a chloride of silver is changed by that agent to a violet hue?

We have before alluded to the comparatively insensitive nature of silver in combination with albumen, consequently, a weak light will show the presence of the more sensitive chloride of the metal better than a strong one, because, under the influence of the last-named conditions, a larger portion of the organic compound is reduced, and its characteristic brickdust colour overpowers the modest violet hue the chloride produces, for the following reason:—"Among the molecules that reflect colours of a single order, those which furnish red are the thickest, and those that give violet are the thinnest." Hence it will be perceived, that the greater the reduction of albuminate, the smaller will be the tendency of the chloride salt to give visible evidence of its presence.

Turning for the present from this engrossing subject, we come now to inquire the time necessary for floating papers on the silver solutions.

Under the old system of sensitizing, this subject required some degree of consideration, as it was necessary the time of floating should be regulated by the strength of solution employed; but, with the bath recommended in our last paper, the difference is scarcely discernible, whether floated five or ten minutes, when the due proportions of bath salts are present; this may be ascertained by the solution becoming discoloured or remaining clear; if the former, and the liberated albumen remains freely in solution, there is an insufficiency of soda; if, on the contrary, the organic substance is precipitated, then is there a lack of silver. In either case it would be necessary to shorten the time of floating, although, for results' sake, we strongly advise that the solution be at all times kept in a proper condition. Our usual time of floating is about four minutes. The paper is

then hung up a short time to drain off the superfluous liquid, when the drying is completed, on an ingeniously designed hot-water apparatus, which was invented by the gentleman in whose service we are at present engaged.

The paper having been placed for a few minutes in a damp place, it is now ready for exposure in the pressure frames; it is, therefore, necessary we say a word or two on the subject of printing. The brilliancy of a picture, doubtless, depends in the greatest measure on the quality of the negative, but, at the same time, a bad print may be produced from a good negative. Whilst, under proper treatment, a passable impression may be secured from an indifferent negative. The gentleman amateur, with time abundant at his disposal, if his negatives possess any good qualities at all he should never produce a really bad print, because his field of operations being limited, an opportunity is afforded for studying the peculiarities of each negative, and treating it accordingly. With the professional printer, the case alters. With a large number of frames under his care, but little time can be spared to study the requirements of his negatives; it therefore becomes him to observe an easily practical method. In our printing operations we entertain a decided aversion to direct sun printing, except with strongly contrasted negatives, for it seems to us the reduction effected by a strong light does not produce the fine gradation of light and shade so easily obtained from a good negative in diffused light. Another objection to sun sealding, is its tendency to produce a mottled appearance in the prints; its production is brought about by the bright rays permeating the minute holes which may be seen in the films of most iron-developed negatives, the paper surface in the vicinity of those apertures receiving the strongest light, a proportional amount of extra reduction is effected, which, in the finished picture, bears a strong resemblance to mealiness, because the sheltered portions print lighter. Diffused light cannot penetrate the interstices described; it therefore follows that printing under the last named conditions proceeds more evenly. The day's printing finished, we pass the pictures rapidly through three waters, and they are ready for toning, the theory and practice of which we hope to enter upon in our next "Jotting."

THE TRIPLE ACHROMATIC LENS.

BY J. H. DALLMEYER.

HAVING been requested on several occasions to furnish a more detailed description of the form and construction of my Triple Achromatic Lens than has yet appeared, I take this opportunity of doing so—the more so now, since imitations have lately been put forth by others laying claim to originality.

Before I enter upon a description of the instrument itself, I will briefly refer to its origin.

Some three years since, when reading a paper before the London Photographic Society, entitled, "On the Nature of Distortion," and printed in the PHOTOGRAPHIC NEWS, June 15, 1860, I endeavoured to point out by familiar illustrations the kind of distortion belonging to each of the two groups of view-lenses then commonly used by photographers, viz., the achromatic or single combination meniscus, and the new Petzval combination, called by the different makers orthographic, orthoscopic, &c., &c. At the same time, I also pointed out the fact known to some, that a double or portrait combination, furnished with diaphragms placed between the two combinations in the ratio of their foci, would produce an image approximately free from distortion.

My attention had been called to this subject by a communication from Mr. Rothwell, of Manchester, in which that gentleman showed the possibility of curing distortion in a double combination.

The lens I brought under the notice of members on the above occasion, was a somewhat modified form of portrait-lens, possessing a flatter field of view than others in use at that time, which was provided with stops in the proper

position to ensure freedom from distortion. Thus I endeavoured to supply in one and the same instrument, a portrait and (when used with a diaphragm), a view lens, producing an image practically free from distortion.

How far I succeeded in this attempt is known to those who purchased these lenses, previous to the introduction of my triple achromatic lens in August, 1860.

I experienced, however, soon after the reading of the above paper, and the manufacture of the lens in question, that photographers generally, but more especially amateurs, were chiefly anxious to obtain a lens for views only, which should be free from distortion: and since, in my double combination, alike suitable for portraits and views, the diameters of glasses had to be comparatively large, therefore thick and also expensive (objectionable on both accounts), I was induced to abandon my first idea of supplying the required view-lens, free from distortion, in the form of a portrait combination.

I now turned my attention to a lens referred to in my paper, and in the following terms. Speaking of a double combination with cemented contact surfaces as suggested by Mr. Rothwell, and free from distortion, the field of which was, however, much curved, I observed:—"But being already familiar with the theorem before alluded to, I suggested to my late father-in-law (Mr. A. Ross), that a *negative combination* placed in the position of the stop, would have the desired effect of flattening the field. . . . Mr. Sutton, who had previously given a familiar illustration of the manner of action of Professor Petzval's negative combination, afterwards also suggested the use of such a one to perfect Rothwell's combination."

From this it will be seen that I suggested the use of a negative combination between the two positives for the reason given, and before Mr. Sutton made his suggestions.

But it will readily be admitted that to suggest a combination is one thing, and to carry it out successfully is quite another; and whilst I had obtained nothing whatever in suggestions from Mr. Sutton, in working out the idea, I have never derived any assistance from any one at all.

An incident I cannot forbear mentioning, occurred at this time, which further stimulated my endeavours for a solution of the question. A gentleman well known in several departments of science, called upon me after I had read the paper already referred to, and commissioned me to construct for him, without regard to cost, a view-lens to be free from distortion, which resulted in the production of the "triple achromatic lens," some three months after.

When setting about its construction, I proposed to myself the following problems for solution:—

1. That the instrument should consist of three combinations, two positive and a negative, each of such power, form, and so placed as to cause the refracted, and, finally, emergent pencils, to be parallel to the several incident ones—an indispensable condition for the production of an image free from distortion.

2. That it should be principally available for groups, views, and copying: the largest aperture not to exceed one-tenth or one-twelfth of the compound focal length.

3. That it should be free from spherical and chromatic aberration; each of the three combinations to be achromatic in itself.

4. That it should cover with equal illumination a circular area embracing an angle of 45° and, when stopped down, 60° or more.

5. That the field so covered should be as flat as possible, consistent with moderately good marginal definition.

- 6 (and last). That its cost should be moderate, and not much exceed the price charged for view-lenses then in use. This latter point controlled the expenditure of optical means.

I need scarcely mention that the solution of these propositions was by no means an easy task. Besides the ordinary elementary treatises on optics, I had only the papers by the present Astronomer Royal "On the Spherical and Chromatic Aberration of Eye-pieces," and a few pamphlets by Professor

Petzval to draw upon; but by the aid of these and trigonometrical projections and calculations, afterwards, also, by practical trials, I succeeded, after three months of constant application, in the completion of the "triple achromatic lens," now possessed, without exception, by all the first photographers both in this country and abroad, and which I humbly believe is the best that can be accomplished out of the optical means therein employed.*

The accompanying diagram will facilitate my description.

I will commence by stating that in the sketch the lenses are mounted in what is called a rigid mount or tube; but, as is known, they can also be had in tubes sliding in outer "jackets," and, if required, furnished with rack-and-pinion movement.

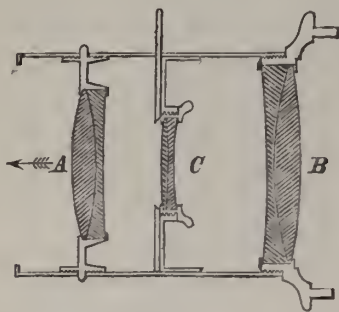

A and B are what are called *positive* combinations, both achromatic, and both also externally slightly of the meniscus form or concavo-convex, the radii of curvature being in the ratio of their focal lengths. Assuming I as the focal length for A, that of B is 1.5, their diameters being nearly in the same ratio. The distance or separation between A and B, expressed in terms of focal length of A, is one-seventh of A.

Between A and B, dividing the distance between them in the ratio of their focal lengths, is situated the *negative* combination C; this is also the place for the diaphragms. Like A and B, combination C is achromatic and externally slightly of the meniscus form.

Its focal power (negative), is barely half of A added to B, and its diameter is about two-thirds that of A.

The equivalent focal length of the whole combination is to that of A as 7 to 8.

When requiring to use the instrument for views or copying up to equal size, combination A (the smaller), should always be turned towards the object or landscape, and B (the larger), towards the ground glass of the camera; but, for *enlarging*, the combination should be turned round or reversed, B pointing to the object to be *enlarged*, and A to the screen or sensitive surface in the camera.

For groups and instantaneous effects, the lens should be used with the largest possible aperture, so as to attain the maximum of rapidity; but for landscapes and the like, where time of exposure is of minor importance, smaller diaphragms may be employed, always recollecting that what is called depth of focus, can only be legitimately obtained by the use of small stops.

To ensure freedom from distortion, the camera should be carefully levelled.

I may mention that, if desired, combination C can be unscrewed for cleaning or removal, by first unscrewing combination B; when using A and B alone, the back focus is shortened by about one-half, and consequently rapidity of action is much increased; but, although, achromatic in this condition, the field of view is much more curved, and, except for vignette heads and sitting figures, it should not be resorted to as a portrait lens.

For out-door portraiture, groups, and the like, it is

recommended that the three combinations be used intact, as they are.

In conclusion, I will offer one or two remarks about another new lens introduced, since mine, by Messrs. Harrison and Co., of New York, and sold under the name of "The Globe Lens." Now, without saying one word about the merits or demerits of this instrument (which, by the way, comes a little too late, in supplying what photographers already possess, viz. a "view-lens free from distortion"), it appears to me to be so very limited in its application, on account of the very small aperture necessary to obtain anything like "crisp" or perfect definition even in the centre, that I do not consider it an advance upon my Triple Achromatic Lens.

ONE OF THE CAUSES OF PIN-HOLES IN NEGATIVES.

BY J. W. SWAN.

PERHAPS some of your readers may have been troubled with pin-hole specks, and may be glad to know the cause and the remedy.

The peculiar kind of blemish referred to has the following characteristics. The pin-holes generally occur in a line, exactly opposite to the division where the shutter of the dark slide is hinged for folding.

The cause is *dust* drawn in through the slit of the dark slide in the act of opening the back of it. The opening of the back, especially if it fits closely, operates like the opening of the boards of a bellows, and produces a strong inspiration of air which carries with it any loose particles of dust that may be lodged in the slit of the shutter, and shoots them, in a strong jet, against the surface of the plate opposite. Each particle of dust so deposited forms the nucleus of an abnormal action of the chemicals, and causes a spot or speck.

The remedy is obvious. Have the back of the dark slide slightly reduced in size, so that it fits quite loosely, and be careful to open the slide softly,—not with a sudden pull.

The manufacturers of photographic apparatus ought to be made aware of the facts I have described, and required to modify the construction of their dark slides accordingly.

It is very evident that at present this phenomenon and its cause are either not known, or not regarded, and this is most true of the best class of apparatus, in which the fit of the back is often absurdly made almost air-tight.

PROTO-ACETATE OF IRON AS A DEVELOPING AGENT.

BY M. MC. A. GAUDIN.

Thus far, the best developer with an iron base appears to me to be the proto-acetate. I have frequently failed in preparing it, except by the way of double decomposition, which method is, I think, too irksome for most operators. We know that the protosulphate, so much employed, does not yield very intense blacks; the skies, for instance, always require to be intensified, and even covered with some opaque substance. Pyrogallic acid goes a little farther, but the proto-acetate of iron alone accomplishes our purpose.

The following expeditious method I have found quite successful. Some sulphate of iron and carbonate of soda are pulverized and dissolved separately in a large quantity of water; the carbonate of soda is poured into the sulphate of iron until a precipitate ceases to fall. After leaving the mixture some time to settle, the supernatant liquid is poured off, and the greenish mud is thrown upon a funnel, covered with a piece of moistened linen, folded double; after the water is drained off, a fresh quantity is poured on, and when the draining is complete, the carbonate on the filter is put into a stoppered bottle, or it may be employed at once for making the proto-acetate. To this end, we add a given quantity of *acetic acid*, diluted with water, which reacts upon the carbonate much better than concentrated acid; but this must be done in an open vase, on account of the effervescence

* The draughtsman has not secured quite the proportions of the combination, nor the true figure of the lenses.

and froth produced. In the course of a few hours, stirring the liquid, from time to time, the proto-acetate is made, and may be filtered through paper. It passes through the filter under the aspect of an orange yellow liquid. It cannot be employed in this state, for, upon pouring it on to a negative to develop it, it immediately forms an inky black deposit over the whole surface of the plate. This defect may be completely remedied by adding sulphuric acid, until the brown hue is changed into a greenish yellow. It still frequently causes fogging, although it may have this hue; in that case, a little more sulphuric acid must be added. When at length it leaves the parts not acted upon by light in all their purity, it is sufficient to add a little alcohol, to cause it to spread more readily, and then the solution of proto-acetate of iron may be kept and employed like sulphate of iron, except that it is not necessary to pour it on to the plate so rapidly, or in excessive quantity. Its effect takes place in a few minutes, and the picture may be strengthened indefinitely by adding nitrate of silver of the strength of two per cent., after the acetate, and some acetate after the nitrate of silver.—*La Lumière*.

A LESSON IN PHOTOGRAPHY.—No. 16.*

TANNIN PROCESS.

(Report of a process as practised by Col. Pike, New York.)

The glass plates, as usual in dry-process operations, must be uniform, homogeneous, free from flaws both on the surface and in the material, and flat. The first operation is to abrade the edges all round on both surfaces with a file or emery stone. The second consists in cleaning and polishing the surfaces. New glasses are fixed in the vice; tripoli or rotten stone is next dusted on the surface, and then a sufficient quantity of alcohol is poured upon the rotten stone. With a small piece of rag or Canton flannel rub the surface in all directions, taking up the mixture of alcohol and tripoli as you proceed.

As soon as one side is thoroughly cleaned from all adhering matter, polish the surface with a clean rag, with chamois leather or a silk handkerchief, as may be most convenient; then turn the plate over in the vice and proceed in like manner with the second side. Seizing the plate with a silk handkerchief in the left hand, loosen the screw of the vice and remove all dust from the edges all round, as well as from the two surfaces, and place it away against a wall or partition until a sufficient number have been prepared.

The third operation is to flow the plate with albumen, which is prepared in the following manner:—Take the whites of eggs and beat them up into a perfect froth, and leave the latter to settle for twelve hours or more. To each ounce of the resulting liquid add half a drachm of alcohol and a piece of rock candy as large as half a pea; dissolve the latter and filter. The albumen is now ready to pour upon the clean plates.

Taking each plate in the left hand, between the thumb and finger, grasping the left hand nearer corner, pour a quantity of the prepared albumen on the nearer end of the plate sufficient to cover the whole surface. The albumen thus poured on is spread evenly by means of a long strip of glass about half an inch in width. Holding the glass by one end in the right hand, lay it almost flat upon the albumen, and in such a manner as to press it backwards towards the thumb so as to cover the nearer end of the plate; then, changing the inclination of the glass spatula, press the albumen to the other end, taking care to cover the whole surface; remove the spatula, and pour all excess of albumen by the right-hand further corner into the vial from which it was received. The plate is now put away to drain on a rack, which is constructed as follows:

Take two pieces of wood, half an inch or more in thickness, eighteen inches long, and three inches wide. Beginning at

a distance of half an inch from one end of either piece placed side by side on the table, draw transverse lines parallel with the end across the two pieces, and thus proceed and rule similar lines parallel with the former at half an inch from the preceding. In this way there will be thirty-five parallel pencil lines on either piece of wood.

Next prepare slips of wood three-eighths of an inch in width and an eighth of an inch in thickness. Tack a separate slip on the end of either of the preceding ruled surfaces, parallel with the ends, and with one side coincident, and whose length is equal to the width of the ruled pieces. Tack another piece at the first line, a third at the second line, and so on to the last. In this way there will be a space of one eighth of an inch between each transverse slip.

The next way is to plane two pieces of half-inch stuff, nine inches long and four and a half inches wide. Bisect one of the longer sides of either piece; and from the point of bisection rule a line diagonally to either opposite corner; beginning at each corner and in the direction of the ruled lines, place the ends of either of the pieces containing the tacked-on slips, and nail them in this position, taking care that the slips look upwards. Do the same thing with the other ends.

In this way we have a rack in which the albumenized glass plates can rest between the slips, in an inclined position, so that the excess of albumen can easily drain off, and the plates can dry.

In the operation of albumenizing it is absolutely necessary to have the room as free from dust as possible. This is effected by first wiping all the shelves, doors, boxes, &c., with a wet cloth, and then proceeding over the floor with a moderately wet mop. By neglecting this precaution dust will be apt to settle upon the albumen, and thus produce specks on the subsequent pictures.

In this way the plates are left to dry spontaneously. When dry, they are ready for the fourth operation: they may be kept in this state, however, for an indefinite time.

In the fourth operation each plate is taken separately and gently heated over the flame of a lamp, and then flowed with collodion in the usual way and sensitized in the bath of nitrate of silver, which must be very slightly acid, but never alkaline. The common hath used in the wet process will be quite suitable in the tannin process. The plate is kept in the silver bath until the surface is uniformly of a cream colour, and free from all apparent streaks or specks of oil; it is then taken out and reared on one end in a pail of clean water, with the collodion side towards the centre of the pail, and left there until a second plate is collodionized and sensitized.

Whilst the second plate is in the silver bath we commence the fifth operation, which consists in seizing the plate in the pail from edge to edge between the right thumb and the second finger, and in giving it a sort of wabbling or undulatory motion in the water, so as to wash off all excess of silver; the plate is inclined at an angle of about 45°. Now withdraw the plate from the water, seize the other end in the same manner with the left hand, give it the same sort of oscillatory motion in the water, the other end being inclined downwards. Holding the plate next as when collodionizing, flow the collodion surface several times with pure rain water, and afterwards immerse the plate in a dish of pure rain or in distilled water, until a second plate is ready to take its place.

The sixth step in the tannin process leads us to the truly tannin part, which is properly the preservative part. For this purpose make a solution of tannin as follows:

Distilled or pure rain water	1 ounce
Tannin	15 grains.

Shake well together until the solution is made, then filter. In some cases the filtration is very slow, and consequently requires some time. Do not forget this, but wait until the solution has all filtered through. Some operators add about 20 drops of alcohol to each ounce of the above preservative;

* From *Humphrey's Journal*.

but this is not necessary where the solution is used immediately. Taking a couple of drachms or so of the tannin solution in a separate vessel, as for instance in a small graduated tube, pour it upon the sensitized plate, already thoroughly washed and drained, but still wet from the last dish; let the surplus flow off at the right-hand further corner into the same vessel, and again cover the plate with the solution, and repeat the operation.

The operations of sensitizing and preserving require an artificially darkened room.

The plate is now in a highly sensitive condition, and has to be placed away in a cupboard to which there is no access of either dust or light, until it has thoroughly drained, and is dry. A cupboard is easily arranged for such purposes, as follows:—

Along the back of the cupboard, stretching from side to side, at a distance from the top of 4 inches, screw on a piece of inch stuff, 2 inches wide. At a distance of 5 inches from the left side, bore a hole half an inch in diameter right through, and insert a vial cork, and pare it level with the wood. Proceeding to the right 5 inches, bore another hole and fill it as before with cork; then go on until there is no longer any more room for more corks.

At 4 inches below the preceding, screw on a similar piece of wood to the back of the cupboard. At a distance of 2½ inches from the left side, bore a hole ¾ inch in diameter, fill it with cork, and let the cork project ½ inch from the wood. At every 5 inches, beginning from the first hole, bore others, and fill them in the same manner with cork. In the middle of the first row of corks, insert the quill end of a feather from a fowl's wing, and cut off all the feather part. In the second row insert in each cork a lady's hair pin.

Pairs of similar rows can thus be constructed along the back of the cupboard.

As soon as a plate has been flowed with tannin, and the excess of the preservative solution has drained off, rear it against the back of the cupboard, with the collodion side towards the back, and the lowest side resting on the bend of the first hair-pin, whilst the right side inclines and rests on the first and upper quill. The rest of the plates follow in succession. If necessary, strips of bibulous paper are placed in the hair-pins to absorb the surplus tannin solution, that drips off from the pendant corner. In this way, a large number of plates can be drying at the same time.

If the plates are intended for the preparation of transparent positives for in-door work, or not for immediate use, they may be retained in the drying cupboard until required for use. On the contrary, if required for outdoor work, they have to be piled away in the changing box, whose description could scarcely be understood without a specimen to refer to, and which cannot be manufactured because it is patented. This changing box, however, is an indispensable *vade-mecum* for the dry-plate process; it is ingenious in the highest degree, and exceedingly practical in its application.

The camera and its lens or lenses, together with the plate-holder, ground glass, and changing box, containing a full supply of plates, in addition to a tripod or camera, compose the whole burden of an amateur for a single day's work; these he can carry beneath his arm without being wearied; and with confidence in his workmanship (to be derived from careful experience), he has the satisfaction of knowing that in the evening, when returned to his domicile, his labour will be crowned, nine times out of ten, with success.

Exposure of the Tannin Plate.

The time of exposure varies naturally with the state of the atmosphere and the season of the year. One very important advantage in the dry process is this: there is much wider scope between the minimum and maximum length of exposure in this process than in the wet process; consequently half a minute too much exposure is by no means so injurious as in the latter. With a good light a negative can be taken of a landscape in about one minute or in a minute

and a half; but two or three minutes will produce, in many instances, excellent results.

The tannin process, however, is invaluable in the production or preparation of transparent positives for the stereoscope, by direct contact. The exposure required in this instance is exceedingly short; half or even a quarter of a second in diffused light will be sufficiently long.

Development of the Picture.

The development can take place immediately, or at any desirable or convenient time afterwards. It has not yet been ascertained how long the tannin plates can be kept between the exposure and development; certainly months have elapsed with little or no diminution of effect.

Developer.—No. 1.

Pyrogallic acid	1½ grains
Distilled water	1 ounce
Glacial acetic acid	½ drachm.

No. 2.

Pyrogallic acid	1½ grains
Distilled water	1 ounce
Citric acid	1 grain
Alcohol	12 minims.

Prepare a filter, place on it the pyrogallic acid, and afterwards pour over it the mixture of acetic acid and water; the filtering can be repeated. The plate is first immersed in water for a few seconds, and then flowed with the pyrogallic acid solution. A sufficient quantity is first poured into a proper measure for the development in question; this is then flowed on and off the plate once or twice; afterwards, three or four drops of silver solution are added to the pyrogallic acid, and the mixture is again poured over the plate and kept in motion, until the intensity of the picture is fully brought out. This mixture, when once used, is thrown away as useless, and the plate is washed and fixed as usual in a solution of hyposulphite of soda. The colour of the print is a beautiful rich black; some operators are of opinion that a little chloride of gold will improve the tone.

DEVELOPMENT OF THE PICTURE. (SECOND MODE OF MANIPULATION.)

Stock Bottle, No. 1.

Pyrogallic acid	2½ drachms
Alcohol	2 ounces

Stock Bottle, No. 2.

Citric acid	1 drachm
Nitrate of silver	½ "
Distilled water	12 drachms

When about to develop a picture, immerse the plate for a moment in rain water, so that the surface becomes uniformly moist; then to a drachm of water, add two drops of No. 1, and one drop of No. 2, shake well, and then pour it over the collodion surface, taking care to keep it moving all the while. As soon as the picture has thoroughly appeared, intensify it by adding drop by drop of No. 2 to the developing solution until the shades are sufficiently intense.

TO PREVENT PAPER FROM TURNING RED.

A CORRESPONDENT of *Humphrey's Journal* gives the following as a method of making excited paper keep well, and print with pure whites in hot weather:—

SILVERING SOLUTION.

Nitrate of silver	1 ounce,
Distilled water	5 ounces.

Take 2½ ounces of the mixture; add concentrated ammonia until it clears itself. When the ammonia is first added it will get muddy and dark, but by repeatedly adding ammonia and shaking the solution, it will become clear, care being taken to get in only just enough ammonia; afterwards add the other 2½ ounces of silver and water, also half an ounce of alcohol. Now the solution will be muddy; again shake well and pour into

your silvering dish *without filtering*. If there is likely to be any scum on the top, skim it off with a strip of writing paper, by drawing it across the top of the solution two or three times, using different strips every time.

Now silver the paper by floating from 15 to 30 seconds, but not longer unless the paper is very highly salted. When hung up to dry, the paper silvered with this solution will keep all day without discolouring, unless left on the silvering too long. When the solution gets low, lay aside and make a new one; by so doing several times, you will have enough old solution, by adding them together, to float paper as if you had a new one. Never add a new solution to an old one; but it can be strengthened if necessary; never filter, but clear the solution by skimming as above. In printing, go very deep, as this toning bath bleaches more than any in use. Wash the prints well before toning; soak them in salt and water—proportions: 1 table spoonful of salt to a pail of water; wash again, then tone with the following bath:—

Muriate of Lime Toning Process for Albumen Prints.

Water	16 ounces.
Chloride of gold	15 grains.
Add 5 grains of salt to make acid.			

Neutralize with carbonate of soda; be careful not to make it alkaline, as it affects the action of the gold. Afterwards add

Muriatic acid, C. P.	10 drops.
Chloride of lime, if fresh	3 grains.

If the latter is not fresh, it will take about 5 grains. This bath tones a rich purple black and works very uniform; it can only be used once.

Fixing Solution.

Hyposulphite of soda	$\frac{3}{4}$ pound.
Sub-carbonate of soda	100 grains.
Wash the prints well before fixing.			

Correspondence.

PHOTODIAPHANIE.

SIR,—I beg to inform Mr. Cooper that I have used Ponting's Bristol Varnish for the purpose he names. I should be glad to know of a harder varnish; but it answers very well, and will bear careful washing with soap and cold water. Apply with a good-sized camel-hair brush, then hold to a bright fire until the varnish is set; it may then be coated again, brushing the other way.

The film is easily placed on any part of a vase, if the following simple plan be adopted. Place the vase in a large vessel of water, lift the film out of the basin with a camel-hair brush, and place in the vessel containing the vase; now gently touch the film with the brush to make it float out flat on the top of the water, this may be done in two minutes. If now the point of the brush be placed in the centre of the film and the vase gently raised with the other hand under it, both may be brought out of the water without any tricks on the part of the film. It may be moved with the brush a considerable distance, if this is done directly it is taken out of the water.

In washing, I do not find it necessary to use more than two basins for several films, as they may all be put into one basin whilst the water is being changed in the other. There is no fear of their hurting each other.

I have been induced to make these remarks because I am very much pleased with the process, and find it very much more *simple* than I expected. It answers admirably for stereoscopic transparencies, which ought, therefore, to be produced much cheaper than they have hitherto been.—Yours, truly,
J. BURGESS.

Lower Goat Lane, Norwich.

[Our correspondent mistakes Mr. Cooper's want, we fancy. If we understand him, he wants an opaque, or translucent white varnish, to form the whites when the transferred film is placed on transparent glass.—Ed.]

Photographic Notes and Queries.

THE USE OF A LENS IN PRINTING.

SIR,—The first article in a recent number of the NEWS is no new thing in my experience. For some years I have used it when necessary. At first I used a lens as you suggest; but I found there was a shade produced on the negative, by either my hand or the frame in which I had set the lens.

I remedied this by procuring a small hand convex reflector, and I could thus throw an extra power of light on any part of the negative; and by putting the reflection slightly out of focus, I thus get quit of the danger of burning.—I am, Sir, yours, &c.,
K.

SUBSTITUTION FOR YELLOW GLASS.

SIR,—Since the publication of my letter, some weeks since, respecting the pigments used for rendering glass non-actinic, I have had several gentlemen called upon me, in order to satisfy themselves on the point, also letters from different parts of the country and the continent, complaining that they could not obtain the Japanese gold size anywhere; it is not Japanese, but Japanners' gold size (the former being an error in printing), that is used. Many thought that it contained colouring properties, because it was gold size; but, as you are quite aware, it is not so. The size being merely the vehicle to temper the pigments, and to assist the drying. There are other pigments that contain colouring matter, much more beautiful than raw sienna or orange chrome, when viewed by transmitted light, such as Indian yellow, yellow lake, &c., but they are more or less fugitive, and cannot be depended upon, when exposed to a strong light; whereas, those I have selected are permanent in themselves; the one being earthy, and the other chemical. They cannot, moreover, act injuriously upon each other.

Having been many years an art-student, but finding photography so close to my heels, I felt obliged to take it up and unite it to my profession, and I find, so pleasantly do they jog along hand in hand, that I very much regret I did not embrace it years before; but there is a vast field before us yet, and I hope the time is not far distant when artists will use photography as a companion to painting.

A few days since, a gentleman (an amateur) called in for his carte, and was much surprised to see so much light in my laboratory (a dark room it cannot be called). I referred him to the PHOTOGRAPHIC NEWS. He said he did not take it. I then told him what it was, and what it cost. He was surprised—at the same time sorry—as he had just purchased some yellow glass, and gave as many shillings per foot for it as mine had cost pence. I am glad, sir, that your readers, some of them, are profiting by the hint. Many, no doubt, are still using yellow silk and calico, which does not admit near so much light, and more expensive and liable to fade. When I commenced photography, which I did at the Portland Bazaar, in the spring of last year, I felt no hesitation in adopting the colours named as a substitute for yellow glass; and finding it answered the purpose so well, and did not fade, I thought the hint would be useful to many of your readers; but, on the subject of fading, I was doomed to disappointment, for, one Sunday morning I had the melancholy fact before my eyes that all I was possessed of in the building was fast disappearing before that terrible element—fire—and in less than an hour, negatives, book pictures, apparatus, furniture, and all were gone, not an article was left; so that you were quite right, sir, in saying that I was a severe loser; and, also, I have to thank you for a word in season; but, sir, as I never learnt the art of shivering, I am in consequence a very bad beggar; so I must leave the matter in your hands, with an humble appeal to the generosity of the photographic public to assist one in time of need.—I am, Sir, yours truly,
47, Baker Street, October 6th, 1863. E. ALDIS.

Talk in the Studio.

TRANSPARENT COLOURS FOR PHOTOGRAPHS.—Mr. Burgess, of Norwich, writes—"Some weeks ago, I sent you some coloured portraits, and promised to explain how they were done. Multiplicity of engagements have prevented my redoing the

promise hitherto. I use Judson's dyes, diluted with spirits of wine and water, and mixed to form the various tints required. Wash on the colour, and blot off again with clean blotting paper. The albumen seizes the colour directly, and will not wash off again.

SPOTS ON NEGATIVES.—Among the many difficulties that attend negative making, there is none more vexatious than those troublesome little transparent dots or comets which so frequently mar the beauty of the plates; they are caused by the collodion being alkaline, and may be remedied by adding one drop of saturated tincture of iodine (alcohol added to dry iodine) to each ounce of collodion. Specking, as it is termed, arises from the same cause, and is cured by the same remedy.—*Humphrey's Journal.*

DRY COLOURS FOR PAPER PRINTS.—We have received from Mr. Nowbery, of Longton, a specimen of his method of colouring paper prints with powder colours, from which it appears the tints adhere with great facility, and are then preserved by the application of a suitable varnish. In the hands of persons of skill and taste some very pretty effects may be produced.

BROMO-IODIZED COLLODION AND PYRO DEVELOPMENT.—We extract the following from an interesting private letter from Dr. Hemphill:—"I have read with a great deal of pleasure, and I hope with profit, the long correspondence in your journal about the advantage of iron over pyrogallie acid in the developer, but it seems strange to me that the use of bromo-iodized collodion, with pyrogallie development, appears all but ignored amongst photographers, although the beautiful Eastern views by Mr. Bedford were produced in that way. I have long used for landscape work bromo-iodized collodion (latterly Ponting's or Thomas's), with a developer of pyrogallie acid with acetic and formic acids, the latter not always, and the advantages I supposed to be derived from it were greater rapidity and softness than with iodized collodion and pyro, and greater intensity than with iron; but this year I have used Ponting's bromo-iodized collodion, with a strong iron developer, both for views and portraits, and find that in most cases in a good light I can produce sufficient intensity with the first application only: 30 grains of sulphate of iron, or 40 of the double salt to the ounce. Should you think them worth your acceptance, I will send you in a little time copies of some portraits and landscapes taken in that way for next year's Amateur Photographic Association."

MOUNTING PHOTOGRAPHS.—One of the great troubles of amateurs, who desire to mount a few prints, is the necessity for making fresh starch for the purpose. When they desire a large number of prints mounted, it is wise, as we have often recommended, to employ the professional mounter, than whom we know none more skilful and obliging than Mr. Fox, of Little Britain; but it often happens that the amateur desires to mount one or two, or half a dozen prints. They are not worth the trouble of sending to the professional mounter, especially if the amateur reside in the country, and, moreover, they require to be done at once. Gum has been abandoned as apt to turn acid, and injure the print; glue requires preparation, so does starch. The trouble of preparing either is not great, but it is just sufficient to delay the mounting and make it a bore. What is required is some adhesive material which may be kept always ready for use at a moment's notice, easy to use, efficient when used, and innocuous to the prints. Mr. Hughes, of Oxford Street, has just sent us a bottle of such a preparation, under the name of "Hollis's Opal Mucilage." It answers admirably, spreads smoothly, adheres well, and is clean and pleasant to use. It will keep indefinitely without becoming acid, rancid, mouldy or dry. It is sold in wide-mouthed bottles at 6d. and 1s. It would be a great boon if it were sold in bottles similar to those often supplied with office gum-water; *i. e.*, a metallic top, screwed on, with a brush passing through. Mr. Hughes has also sent us some samples of very excellent mounts with India and fancy tints. These tints are on stout board, not plate paper, to which many photographers object, as being thin and apt to cockle and to break. Also some card mounts with fancy borders: these latter are not to our taste, but they will please some, and are well executed.

To Correspondents.

J. HOLLAND.—Mr. Hardwich's "Manual" is the only work specifically devoted to photographic chemistry.

C. W. L. F.—By the method of "vignetting a picture, and yet having the

ground of a peach colour," we presume you mean the effect produced by double printing, which we have two or three times within the last few months described. The print is vignettted in the usual manner, and then the printed portion is covered with a mask rather smaller than itself, which is kept moving whilst the white grain is exposed to the action of light until it attains a proper depth of tint. This, when toned, possesses something of a peach colour.

HENRY THOMPSON.—We do issue an index at the end of the year; each year's numbers constituting one volume. We also issue a cloth case for binding. 2. There are two methods of obtaining collodion positives on cloth: one consists in attaching the glazed cloth to a glass, and coating and working it in the usual way; and another in transferring the film containing the completed picture from glass to the cloth. There are several ways of doing this: a very simple one consists in pouring on the completed picture a little alcohol, containing a few drops of nitric or sulphuric acid to each ounce, and the same mixture on to the surface of the cloth; place them in contact, and rub down to expel air-bubbles; place in a pressure-frame, and when quite dry, the cloth may be lifted away, bringing with it the picture. 3. As an enlarged copy from a glass positive, the print you enclose is very good indeed. 4. Photography is, we believe, very successful in Australia, but whether there is there an y better opening for a skilful photographer than at home, we cannot tell.

MEXICO.—Sea air will not affect negatives properly packed. You will not, we believe, have to pay any duty.

HOLLAND.—We believe each of the collodions you name are good; but we should prefer the second on your list. 2. For paper, the last mentioned. 3. For lenses, the first on your list.

AN IGNORANT AMATEUR.—After completing your development, and carefully washing, you may take your negative into diffused light to fix. If you do not obtain sufficient intensity in the face, it may arise either from the use of an unsuitable collodion or from not having the face well lighted. You may easily obtain sufficient force by intensifying again after fixing.

J. BELDON.—The letter was duly addressed and forwarded.

T. P. E.—The only method you can adopt is to separate the ashes as carefully as you can from the sulphide, and all that cannot be removed must go into the crucible, and will be separated there.

OMNINO VICTOS.—We have never seen round insensitive spots so large as a quarter of an inch in diameter. The only suggestion we can make is that you have probably dropped some solution on the plate from the bottom of one or other of the vessels used in some part of the process. 2. It is always difficult to state the exposure which ought to be given, so much depends on the exact nature of the light and the illumination of the object; but it is quite impossible to do so without knowing what aperture you wish to use. You state that the lens has a focus of 15 inches, and the diameter 3 inches; but you omit to mention the stop.

T. R. II.—We have no personal knowledge of any one who takes microphotographs. A few weeks ago we inserted, in "Answers to Correspondents," the address of a gentleman, Mr. Jaglis, who, we believe, undertakes the work.

A.—You cannot very successfully undertake to bleach shellac yourself, but you may purchase it, perfectly white, of almost any chemist. The process, however, renders it very difficult of solution. Varnish-making requires more appliances and more experience and skill than most amateurs possess. The addition of an essential oil after such as that of spike or lavender facilitates solution. A variety of circumstances influence the best proportions.

HARRISON FRODSHAM.—The substitute for yellow glass, referred to in No. 253, was given under the head "Notes and Queries," in No. 258, PHOTOGRAPHIC NEWS. If you wish to try the formula in 261, substitute for Orleans, orange chrome.

II. PIRETT.—See answer above.

XENOPHON.—Your portraits are, as they have been pronounced, "pretty good for the work of an amateur." The chief fault is a little tendency to hardness, arising probably from a little over-intensification. The best are 3 and 5, both of which are good pictures; 1 and 6 would probably be good if they were well printed and toned. You must take more care to get an even film, and so avoid many irregularities in the background.

J. A.—We have not had much experience with the leuses in question; but what we have is not very favourable. 2. Unless you pile up the deposit by means of silver and pyrogallie acid very rapidly and so coarsely, it ought not to sensibly injure the sharpness of your image. Try to master that method, it is the safest plan for general use.

AQUA PURA.—We are not familiar with the powder enclosed. 2. You may, probably, be able to obtain a description from the firm named. Several Correspondents in our next.

Reviews of Wilson's New Stereographs, Dr. Hemphill's Views in Ireland, Sutton's Volumetric Analysis, and Brother's Portraits of Engineers, together with several articles in type, are compelled to stand over until our next.

Photographs Registered during the Past Week.

- MESSRS. KERR AND RICHARDSON, Glasgow,
Two Photographs of Lord Clyde, from Ewing's Marble Bust.
- MR. J. DAVIS BURTON, 194, Oxford Street,
Five Photographs of Mademoiselle Linas Martorelli.
- MESSRS. NELSON AND MARSHALL, 11, Upper Sackville Street, Dublin,
Photograph of Sims Reeves.
- MR. A. GOODCHILD, Redcar, Yorkshire,
Photograph of Rev. Albert Sidney Wild.
- Photograph of Rev. Albert Sidney Wild and Mrs. Wild.
- MR. JOHN HILL MORGAN, Parklands, Tyndalls Park, Clifton,
Photograph of the late Sir John Kerle Hlaberfield.
- MR. WILLIAM EDMETT, 10, Melbourne Street, Staleybridge,
Two Photographs of Samuel Laycock (Poet).
- MR. THOMAS WILKINSON, 121, Snargate Street, Dover,
Photograph of a Curious Egg.
- MR. JAMES BEAKE, 44, Lower Ormond Quay, Dublin,
Photograph of the Right Hon. James Whiteside, M.P.
- MR. W. W. WINTER, 2, Midland Road, Derby,
Design representing France and England United in the Science and Art of Photography.

THE PHOTOGRAPHIC NEWS.

Vol. VII. No. 269.—October 30, 1863.

CONTENTS.

	PAGE		PAGE
Strength of the Printing Bath.....	517	Recent Patents	523
Critical Notices—A Systematic Handbook, &c.—Album Photographs—Photographic Illustrations.—A Group of Photographic Engineers and Opticians.—Stereographs of the English Lake Scenery	518	Analysis of the Silver Solutions used in Photography. By Francis Sutton	523
Jottings from the Note-Book of a "Photographer's Assistant." No. V.	519	Proceedings of Societies—North London Photographic Assoc....	524
Rapid Testing of Collodion. By M. Mc. A. Gaudin.....	520	Correspondence—Foreign Science—Photography in Colours—Cheap Battery for the Electric Light	525
Nitrate of Ammonia. By Carl Meinertzh.....	520	Photographic Notes and Queries—Fraudulent Chloride of Gold—Perambulator Tent	526
On the Behaviour of Chloride, Bromide, and Iodide of Silver in the Light, &c. By Hermann Vogel.....	521	Talk in the Studio	527
		To Correspondents	528
		Photographs Registered during the past Week.....	528

STRENGTH OF THE PRINTING BATH.

THERE is no subject of greater importance to the photographer than the proper strength of the silver solution used in printing. There are two aspects in which the question claims attention—the artistic and the economic. It is of primary importance that the best results possible from the negative should be secured; and it is necessary that these results should be obtained at the least possible waste of the precious metal. Perfect results must not, in any degree, be sacrificed to economy; but there should be no expenditure which is not accounted for in the results obtained. The subject of the discussion at the last meeting of the North London Photographic Association is, therefore, worthy of a more extended and experimental attention.

The question really resolves itself into this:—What is the minimum strength of silver bath with which the maximum of excellence in printing may be obtained? There are three distinct operations to be performed by the nitrate bath in exciting albumenized paper. It has to render insoluble, or "coagulate," the albumen; to convert the soluble chloride combined with the albumen into chloride of silver, and to supply the requisite proportion of free nitrate of silver necessary to rapid and vigorous printing. Any strength of solution which performs these offices, or any of them, imperfectly, will yield bad prints, and fail in securing the primary end of printing. Any proportion of silver present more than is necessary for these ends is wasteful, and fails in securing the second condition, economy.

The advocates of strong baths advance various reasons, many of which are very cogent. First, in regard to the process termed "coagulation," they state that this, is rapidly performed before the water in which the silver is dissolved can exercise any solvent action on the albumen, whilst a weak solution attacks the albumen at once, and dissolving part, not only robs the paper of some surface and brilliancy, but also rapidly contaminates the nitrate bath. That the strong bath converts all the chloride present into chloride of silver rapidly, and so requires a short floating, by which the sensitive salts are largely kept on the surface, and an important condition of brilliancy secured. That the proportion of free nitrate necessary for good results being an uncertain quantity, is at least made safe by the use of a strong bath. And finally, that practice demonstrates the advantages of a strong bath in prints of greater force and brilliancy than can be obtained by a weak solution. These are the chief arguments they advance as to the value of strong baths in securing the first condition, good results; and in regard to the second condition, economy, they urge that all the silver not actually used in producing the image may, by care, be recovered, if the various residues be properly preserved.

The advocates of weaker solutions simply affirm the strong ones to be unnecessary, and therefore wasteful. That the albumen may be rendered insoluble by solutions of twenty or thirty grains to the ounce, instead of sixty, eighty, or a

hundred grains. That the whole of the chloride may be converted into chloride of silver by a longer floating on the weak solution, as easily as by a shorter floating on a strong solution. That the necessary proportion of free nitrate is supplied by the weak solutions, and that practices demonstrate the sufficiency of the weaker solutions in all cases where paper and judgment are used.

On the score of safety, the advocates of strong baths have doubtless the best of the argument; but if satisfactory conditions can be defined, there is no need to go to an excess to secure safety. Strong solutions do unquestionably rapidly "coagulate" the albumen, and thus prevent any portion from being dissolved; they also permit a short floating, and thus prevent the silver solution from soaking so completely into the paper. Whether this keeps the image so perfectly on the surface, as is sometimes imagined, we are not so sure. This, we conceive, is really more affected by the mode in which the first preparation of the paper is managed, for if the chloride employed have sunken into the paper, it is quite certain that, however short the floating, the silver will follow it. If the paper be new, the size readily soluble, and the floating on the albumen not very rapidly and skilfully performed, the salt will penetrate into the body of the paper, and the silver will follow it, forming as much of chloride of silver in the paper as on its surface. If, on the other hand, a paper be used, the sized surface of which has become hard and firm by age, and if the albumenizing be managed with the rapidity and skill which forms a good surface without allowing the solution to penetrate or soak into the body of the paper, then short floating on the silver bath, will preserve the sensitive coating entirely on the surface, and secure the desired object. The objection to long floating, mentioned by Mr. Shadbolt, is more important. He suggested that if the nitrate of silver soak into the paper and enter into combination with the size, a compound is formed which is difficult to eliminate, and conducive to decomposition and fading.

The question as to the proportion of free nitrate necessary to good results is the most difficult to decide. Its exact office is not well understood. We know that nitrate of silver is not itself reduced by light, and that pure dry chloride of silver alone is insensitive to light; we know also that even when it is in combination with organic matter, if all free nitrate of silver be washed away, it darkens slowly under the action of light; and we know that chloride of silver, in the presence of free chlorine, is insensitive to light. If paper prepared with chloride of silver only, without free nitrate, be exposed to light, it darkens slowly; but as the chloride of silver is reduced by light to a metallic state, chlorine is liberated; so that, after the first action of light, we have chloride of silver and the presence of free chlorine, and consequently a delayed and imperfect action results. If free nitrate of silver be present, it is stated by some that the chlorine liberated, attacks the nitrate, and forms a fresh supply of chloride of silver to add vigour to the image. If this theory be correct, then the proportion of free nitrate

should bear a specific relation to the amount of chloride, and heavily-salted papers would require a larger proportion than lightly-salted papers. Practice alone can, however, satisfactorily determine the proportion of free nitrate which will secure the best results.

The specimens exhibited by Mr. Harman, at the North London meeting, appeared to be, within certain limits, tolerably conclusive. They consisted of a series of prints from the same negative—a somewhat thin one, produced under similar conditions in all respects, except the strength of the nitrate bath, and the time of floating. They were excited as follows:—

No. 1	nitrate bath	10 grains,	floated	10 minutes.
No. 2	"	20	"	10 "
No. 3	"	40	"	5 "
No. 4	"	60	"	3 "
No. 5	"	80	"	2 "
No. 6	"	100	"	45 seconds.
No. 7	"	120	"	15 "
No. 8	"	160	"	5 "

All were exposed under the same negative in sunlight, and toned, &c., together in the same solution. It was difficult to form the most correct estimate by artificial light; but there appeared an unquestionable progressive improvement. The last were certainly better than the first, but it was doubtful whether the progressive improvement was very definitely marked on those higher than sixty grains. The printing of those from the weak baths was said to be slower, and the loss, or reduction, in toning and fixing considerably greater than with those excited on the stronger bath. Mr. Dawson had examples of a few experiments which pointed in the same direction.

On the other hand, Mr. Hislop showed some prints produced from paper excited on a weak bath, which were in no wise deficient in vigour. At intervals during the last two or three years we have received from a very intelligent photographer and highly cultivated gentleman, signing "N," communications on this subject, accompanied by some exceedingly charming specimens, produced on a bath of about twenty grains to the ounce. Mr. Sutton has recently suggested that with a thirty-grain bath, to which a few drops of lemon juice had been added, he obtained on his patent albumenized paper results equal in vigour to those excited on a bath three times that strength. And we have during the present summer, been experimenting with printing baths not much exceeding twenty grains from which we have obtained excellent prints.* Mr. Blanchard, whose prints, whether landscape or portrait, are amongst the best we know, informs us, that after using for some years very strong solutions, the conclusion to which experience has conducted him, is that a uniform strength of forty grains to the ounce gives the most satisfactory results.

Perhaps the most important phase of this subject has yet to be developed. In addition to the prints already mentioned, Mr. Harman exhibited three others, produced on paper excited on a bath containing twenty grains of nitrate of silver and sixty grains of nitrate of soda to each ounce of water. These prints were equal in vigour and richness to the best of those produced on the simple silver bath, however strong. This method of partially substituting nitrate of soda for nitrate of silver was first suggested by a correspondent of the *Photographic News*, signing "Publicola," in April last, who forwarded to us some fine examples of its

* The bath here referred to was slightly acid with nitric acid; but since this article was written, we have carefully tested, with Mr. Hart's volumetric apparatus, a neutral silver bath, from which we had just been obtaining some prints as excellent in all respects as we could desire; brilliant, rich, and free from meanness. About a pint of solution was made for the purpose of experiment early in the summer, the strength being 60 grains to the ounce. This had been used without any renewing until it was reduced to about one-third of its original bulk, remaining neutral and giving fine prints. We were prepared to find it weak, but, on carefully testing, we were surprised to find that it contained only a fraction above 20 grains to the ounce, the exact strength being 20 1/10th grains. The prints last produced were on various samples of paper, and all gave good results. They consisted of Lanpray's (Sutton's patent), Hart's, and Elliott's.—Ed.

value at the time. Since then, our contributor, "A Photographer's Assistant," has been working successfully in the same direction, and has forwarded us some most unexceptionable prints. It is not, of course, supposed for one moment that the nitrate of soda takes the place of a salt of silver in forming the image, but its presence seems to facilitate in some way—upon which we shall have something to say on another occasion—the formation of a vigorous image, and by the prevention of waste, materially economises the working. Even where residues are saved, there is a loss in the process of recovering the silver; and amongst amateurs the various residues would frequently cost more to collect than they would yield: so that the less free nitrate finding its way into washing and fixing baths, the better.

As we said at the outset, the subject generally will well repay further experimental inquiry. We have here endeavoured simply to lay a simple statement of the case, as it now stands, before our readers. For our own part, we have generally counselled the use of strong baths, as giving, with indifferent negatives, and most kinds of paper, satisfactory results. But it is probable that when the conditions are well understood, it will be found that, with moderately intense negatives, a considerable saving may be effected in cost without any sacrifice in results.

Critical Notices.

A SYSTEMATIC HANDBOOK OF VOLUMETRIC ANALYSIS, OR THE QUANTITATIVE ESTIMATION OF CHEMICAL SUBSTANCES BY MEASURE. By FRANCIS SUTTON, F.C.S. London: Churchill.

The practice of photography has conducted largely to increase the amateur study of chemistry; and as analysis by the volumetric method commends itself to the amateur from its comparative simplicity, and from the obviousness of its results which are all apparent to the eye, this work will be especially welcome to the intelligent photographer. Mr. Sutton, whose name is identified by photographers with an excellent manufacture of neutral chloride of gold, has here endeavoured to supply an existing want in the shape of a simple and trustworthy text-book, embodying the experience of the best authorities in this branch of chemistry. We believe this aim has been carefully and conscientiously carried out; the arrangement of the book is excellent, and the style simple and clear.

The experimental photographer is well aware of the importance, as a basis of operations in arriving at just results, of estimating the true value or strength of the agents he is using; and he will find the most valuable aid in obtaining this knowledge, always assuming that he has at least some elementary knowledge of chemistry to begin with, as this is not a book for beginners. On another page we give Mr. Sutton's mode of estimating silver solutions, and we refer the reader to the volume itself for the methods of examining various other important agents used in photography.

ALBUM PHOTOGRAPHS. By G. W. WILSON. Marion and Co., Soho Square.

MR. WILSON has recently issued a large number of his old photographs, as well as those of the present season, in a new form, suitable for preservation in albums especially prepared for them. The size is 4 1/2 inches by 3 inches, and Messrs. Marion have provided for them a most elegant 4to album, with apertures on each page of the dimensions we have named. Important amongst the recently published pictures are an admirable series of Windsor's fine old Castle and its surroundings, and some fine cathedral interiors. To say that these pictures are by Mr. Wilson is to imply that they are admirable specimens of photography and art: that water, and cloud, and atmosphere, as well as foreground, are well rendered; although some of the interiors

are, perhaps, open to exception on the score of converging uprights produced by tilting the camera.

In a few instances, Mr. Wilson informs us, the globe stereo lens was used. Of the qualities of these lenses he remarks: "They are a little slow in working in consequence of requiring to be filed with a very small stop; but they cover a much larger field than the ordinary single lenses, and it was for this reason, and for the purpose of getting straight lines, that I used them. I tried a larger globe lens of about the same focal length as the No. 1 triple, but I preferred the work of the triple; and, indeed, if Mr. Dallmeyer would make a pair of triple lenses of about $4\frac{1}{2}$ inches focal length, they would do all the globes do, and more." For ordinary stereo landscape, in which a wide angle is generally unimportant, Mr. Wilson prefers his single lenses.

There is another feature of interest to name: Messrs. Marion issue these prints coloured as well as plain. We have rarely seen anything in the shape of colouring applied to photographic landscapes which has not in our eyes spoiled them; but here the colour is applied with so much judgment, taste, and skill, just doing sufficient and no more, and that in the right manner and the right place, that an exceedingly fine and natural effect is in many instances secured, and a real beauty added to the pictures. The album is one of the most chaste in design and excellent in construction we have seen.

PHOTOGRAPHIC ILLUSTRATIONS, Selected from the Abbeys, Castles and Scenery of Clonmel and the surrounding Country. By W. D. HEMPHILL, M.D., F.R.C.S.I. Clonmel: J. H. O'Neill.

DR. HEMPHILL has here produced a beautiful little album for which Irish tourists will thank him, and has set an example which we hope many photographers residing in picturesque districts will follow. We have a couple of dozens of charming vignette views, card size, mounted in an album prepared for them, and duly provided with title-page and descriptive index, which gives completeness and interest to the volume. Many photographers are familiar with Dr. Hemphill's photographs from exhibitions; these views are selected with fine artistic feeling, and photographed with skill. The album is also at once good and chaste.

A GROUP OF TELEGRAPHIC ENGINEERS AND OPTICIANS, Photographed by A. BROTHERS, Manchester.

WE have here one of those marvels of composition portraiture, in which Mr. Brothers delights and excels. Twenty-nine gentlemen, whose names are prominently associated with the progress and improvement of the electric telegraph, are here harmonized in one satisfactory group, and all excellent portraits. Prominent in the picture are many well-known faces, whose names will be remembered whenever the engineering triumphs of this age are mentioned. Here are Robert Stephenson, Sir Charles Bright, Professor Wheatstone, Cooke, Ricardo, Latimer Clark, Bouelli, Ewart, and a variety of others. The difficulties in producing a group of this character appear at first sight well-nigh insurmountable. Besides the necessity of obtaining the negatives at different times, when and how it might be convenient to the sitters, nine of them could not sit at all, so that Mr. Brothers had to make use of such copies of photographs as he could obtain. But from these heterogeneous materials, twenty gentlemen sitting at different times, and nine copies of portraits, a group had to be arranged which should do justice to each, and at the same time compose a satisfactory and artistic picture. The completed result, however, shows no trace of the difficulties of producing it; the grouping is simple, easy, and natural, and possesses at once unity and harmony. And notwithstanding the thirty-two printings necessary to produce the original group, no appearance of defective photographic result can be traced in the published

prints. Such photographic triumphs are every way creditable, and we trust that the publication will be as successful as the production is worthy.

STEREOGRAPHS OF THE ENGLISH LAKE SCENERY. By R. J. SPROAT.

THIS series comprises some of the most charming stereographs we have seen, the beauty of the subjects receiving full justice in the perfect photography. The water is transparent, the foliage clear and detailed, and the cloud and atmospheric effects exceedingly beautiful. Ullswater, from Bonass Hotel, No. 80, is a most exquisite picture. Derwentwater Bay and Causey Pike, No. 105, are also exceedingly fine. Windermere Lake, from near Lowwood, No. 100, possesses one of the most perfect banks of clouds we have ever seen rendered, the slide only being removed from perfection by the unfortunate position of a figure in the foreground. Otter's Isle, Derwentwater, No. 107, is wonderfully perfect, as is also the quiet beauty of Grassmere, from Red Bank, No. 99. The perfect rendering of cloud, water, and foliage we find here is very rare, and we shall be glad to learn more of Mr. Sproat and his method of working.

**JOTTINGS FROM THE NOTE-BOOK OF A
"PHOTOGRAPHER'S ASSISTANT."**

No. V.

TONING OPERATION.

THE subject proposed for discussion in the present paper needs no argument to prove its importance, nor does it require a flourish of language to arrest the attention of the photographic reader, whether amateur or professional, as all, by bitter and temper-trying experience, have been taught, that a necessity exists for a more extended knowledge of the principles involved in our toning operations, as under existing conditions the successful issue of preceding labours hangs tremblingly on the satisfactory working of the gold solution, when the prints are exposed to its capricious and oft-times treacherous action.

The changes by decomposition that occur in toning solutions are under the guidance of certain fixed laws, somewhat complex in their operation, but easily brought under control when the governing principles are understood. To attain this knowledge, it is necessary that we begin at the beginning, and end where the researches of many have commenced.

Men are usually too high-minded to submit to the necessity of stooping or creeping when occasion requires; hence little truths are passed over, and they commence their labours at the wrong end, and, as a necessary consequence, tantalizing failures meet them at every turn.

From an early period of photographic history, gold, in combination with chlorine, has been employed to impart a satisfactory finish to the appearance of sun prints; and when employed in union with hyposulphite of soda, its operation seemed to be all that need be desired, but as that tell-tale, time, wended on its swift-winged course, facts were unravelled whose evidence could not be allowed to pass unnoticed. The once beautiful surface of the paper began to assume the changes which ultimately led to the destruction of all for which it was held valuable—yellow! green! fading! gone!! And the lovely image that had so often delighted our eyes was vanished for ever; and, in our despair, we pronounced hypo-toning to have proved itself a deceitful and villanous failure, and as such was cast aside to give room for the newly introduced alkaline process, whose flattering promises caused the knell to be sounded for its yellow-faced predecessor, whilst photographers exultingly clapped their hands to welcome the stranger, through whose instrumentality tones were to be secured as permanent as they were beautiful. But, alas for human hopes! this promising new comer speedily proved

itself to be the most mischievous of all mischief-making imps. By the practice of what was called "dolges," it could sometimes be coaxed into a good humour, and then its thrice happy director would cry, "Rejoice with me, all ye my photographic brethren; give the prints a good ducking, and a few more grains of soda to the imp, and he will work like a Briton." But long ere the printer's echo had ceased to attract attention, the soda bribe had lost its efficacy, and the creature was then said to be suffering from some atmospheric change which had impaired its delicate organization; so, batch after batch of prints, with plague-stricken faces, would be thrown aside, and more propitiations times hoped for. These, with a thousand untold troubles, have, from the first, attended toning operations.

Commencing with the hypo-toning bath, we purpose taking a rapid glance at the various agents which, up to the present time, have secured a recognized place in our gold solutions, when we hope to prove that in all cases the general principles by which decomposition is effected are alike in action, although they are found to vary in detail.

Hyposulphite of soda in symbols is rendered thus—

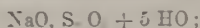

that is to say in each atom of the substance named there exists one part soda, one of hyposulphurous acid, and five water. When an ordinary sun print is exposed to the action of the first-named salt in solution, a portion of the hyposulphurous acid separates from its base and passes over to the unreduced silver, and an hyposulphite of the metal is formed— $\text{AgO, S}_2\text{O}_5$. This process of decomposition calls into action the chloride of gold, Au, Cl . A portion of the chlorine passes over to the soda and the liberated gold takes up a new lodging on the surface of the immersed print. The chief advantage gained by this method of depositing the gold is an entire immunity from mealiness, and it becomes us to inquire into the conditions which prevent the evil; but, ere we proceed in this direction, we wish it to be understood that our remarks on this and every accession are tendered with a spirit untinged with dogmatism, whilst explaining our own views we are at all times open to correction, if proved to be in error.

The affinity that exists between the unreduced silver and the hyposulphurous acid causes one atom of the last-named substance to separate from its base to unite itself with one atom of the metal; this union sets at liberty one atom of soda to attract and combine with the freed chlorine, and common salt is produced. Now, a careful study of these changes at once shows us the reason why hypo toning yields no mealiness. By the action of the fixing salt, the free and unreduced silver is at once removed, and with it all tendencies to engage chlorine in its biting operations, consequently the bleaching agent yields to another source of attraction and unites with the soda, leaving the liberated gold to pursue its course unmolested. If no other interfering agent presented itself, hypo toning would be perfection itself, but, unfortunately, free acid is introduced with the gold, whose superior prowess upsets theories by its dangerous practices, the worst of which is its tendency to set sulphur at liberty; and it frequently happens that a print is sulphur-toned instead of receiving a more abiding colour from the inert gold present in the solution. It may be asked from what source is the sulphur produced? In reply, we would point to the fact that a strong acid will at all times overcome a weak one, and the soda being in combination with the lowest oxide that can exist in the scale of acids, the union is one of the weakest characters, so that no difficulty is experienced in procuring its freedom, and whilst at liberty by some other decomposing, but not undisturbed, process, it yields a colour so like that given by gold that one can scarcely be distinguished from the other.

Theoretically chloride of gold, entirely minus free acid, should in the hypo bath yield permanent tones; but, considered practically, would toning action be set up under those conditions? We believe not although we leave the

question open for those who practice hypo toning to determine; if they answer in the affirmative, then we ask, Does it pay to practice this worn-out system? Without fear of contradiction, we say it does not. A few months ago we were engaged in an establishment where the hypo toning was adopted, and five drachms of the expensive gold salt were consumed in toning 25 to 30 sheets of paper; with our lime and soda solution we would undertake to produce a better tone at an expense of 12 grains of gold for the same number of sheets; and this assertion in itself, we presume, to be argument sufficient to induce every photographer to cast aside his old-fashioned notions, if he has any, and take his place in the race of progressive improvement.

RAPID TESTING OF COLLODION.

BY M. MC A. GAUDIN.

To ascertain whether, by employing the collodion, silver bath, and developer we have prepared, we can obtain blacks in our negative proportionate to the luminous impression, we must place side by side on the same piece of glass very different degrees of exposure; to obtain these by the aid of a single candle would require the counting of a minute or more. We can easily obviate this by causing diffused light to fall during five seconds upon the reverse of the sensitized glass, partially protected by a small piece of oil-cloth cut into a triangular shape, by removing a black screen which covers an opening of about two inches in diameter: then, after having slightly displaced the triangle of oil-cloth applied to the back, we again count five seconds, holding the plate inclined vertically at about two inches from the candle; after again removing the piece of oil-cloth a little, we again count five seconds at two inches from the candle, and then pour the developer upon the sensitized surface. If the three ingredients employed are good, we shall be able to distinguish four perfectly distinct spaces upon the plate; one very black, corresponding to the exposure of five seconds to diffused light, plus the ten seconds to the candle; the second, much less intense, but strongly marked, corresponds to the ten seconds exposure to the candle; the third, half as marked as the second, corresponds to the five seconds exposure to the candle; lastly, the fourth space, corresponding to the absence of exposure, should appear under the form of a small triangle, having perfectly retained the opaline tint peculiar to sensitized collodion without any fogging.—*La Lumière*.

NITRATE OF AMMONIA.

BY CARL MEINERTH.*

SOME six months ago Mr. Anthony communicated (page 302) a process of modification for the nitrate of silver bath by the use of nitrate of ammonia. I have tried it with excellent success, but would wait for reports from other quarters before putting my own forward. As nothing, however, has appeared yet, I beg to offer the result of my experiments and appreciation of Mr. Anthony's liberal contribution.

The term "nitrate of ammonia" seems, to the superficial observer, so much the same thing as the photo-household word "ammonio-nitrate," that we should not wonder if some persons mistake the former for the latter. So a correspondent says, that he took notice of Mr. Anthony's suggestion, but that it had occurred to him six months before: and then he goes on describing the old process of preparing the ammonio-nitrate of silver bath for albumen, as given by Waldack, and recommended by Colman Sellers and other writers in your Journal two years ago.

[When I was reading that article, the nitrate of ammonia which it contained—or rather did not contain—seemed to decompose, and filled me with laughing-gas.]

* From *Humphrey's Journal*.

But I did not see Mr. Anthony's idea in that light. I believed he meant the common salt, nitrate of ammonia—which I sometimes use as a stimulant in watering my plants—and with it I proceeded as follows:—

In 14 ounces of pure water dissolve 1 ounce of nitrate of silver, and in 2 ounces of water 60 grains of nitrate of ammonia. When both are perfectly dissolved, mix together, shake well, and filter.

This gives a 30-grain silver solution, and, after the paper was silvered (1½ minute) and fumed in the ordinary way, yielded prints which came black from the printing-frame and changed but very little in the toning (acetate) and fixing-bath. I send specimens from the second dozen of sheets silvered on the same solution.

[The tone of the specimens sent is very agreeable, of rich purple, such as we have a right to expect from sensitization in a bath of ammonio-nitrate of silver, or in one of nitrate of ammonia and nitrate of silver. There is a difference between these two baths *sometimes*, not always. Let us examine, for instance, the composition of the bath of ammonio-nitrate of silver as recommended by some authors. The requisite quantity of nitrate of silver is dissolved, and the solution is divided into two equal parts as soon as the oxide of silver is all dissolved by the cautious addition of ammonia, which first produces the oxide and then dissolves it. Now what is the composition of the solution at this stage? Is it nitrate of silver and ammonia? Certainly not. We will be more definite and begin again. Add ammonia to the solution of nitrate of silver as long as a brownish precipitate is formed, and remove the latter by filtration. This precipitate is oxide of silver which has been separated from the nitric acid, whilst the nitric acid, by reason of its greater affinity for ammonia, has formed a new salt—nitrate of ammonia holding in solution a certain quantity of the oxide. If now the remaining oxide be dissolved in ammonia and added, we shall have a mixture of nitrate of ammonia and of ammonia holding in solution oxide of silver,

This mixture is divided, as said at the beginning, into two equal portions, to one of which nitric acid is added until it shows an acid reaction. Now, what are we to infer from this? That the ammonia has combined with the nitric acid so as to form nitrate of ammonia with a slight excess of nitric acid, and holding in solution also the oxide of silver. The two solutions are again mixed, upon which we have:

Nitrate of ammonia and ammonia holding in solution oxide of silver, in which the nitrate of silver has entirely disappeared.

In the nitrate of ammonia bath we have:

Nitrate of ammonia and nitric acid holding in solution oxide of silver.

Here there is a difference; but take the case where only one-third of the solution is precipitated, and in which the oxide is afterwards dissolved by ammonia, and then the two solutions are mixed. The formula will stand now—

Nitrate of ammonia and nitric acid holding in solution oxide of silver.

Together with a variable quantity of nitrate of silver and oxide of silver.

Here there is an addition, but scarcely a difference, practically speaking.

From this rationale it is evident that the nitrate of ammonia bath is more rational, if equally good in its toning properties, from the fact that there is no loss of oxide of silver.—Ed. *Humphrey's Journal*.]

PHOTO-BLOCK PRINTING.—Mr. Duncan Dallas, the inventor of a new system of photo-electric engraving, yielding the most perfect results as yet attained in that direction, has recently been enabled to apply his process to the production of engraved blocks, containing the image in relief like wood cuts, capable of being printed at the ordinary printing-press, in conjunction with type.

ON THE BEHAVIOUR OF CHLORIDE, BROMIDE, AND IODIDE OF SILVER IN THE LIGHT, AND ON THE THEORY OF PHOTOGRAPHY.

BY HERMANN VOGEL.*

AMONGST the numerous important discoveries of the present century, interesting in a scientific, industrial, and social point of view, photography occupies one of the first places. Invented by Niépce and Daguerre only twenty-four years ago, it has advanced from year to year, improvement following improvement, until its productions have now attained a perfection by which they leave all graphic art far behind them in truth to nature. In the same measure, the application of this art has extended into all possible departments, so that now, there is scarcely any field in the visible world into which it may not enter with advantage. It draws (by nature printing in the widest sense), the pictures of living persons; it furnishes faithful representations of animals, plants and minerals; it fixes the grand natural scenery of our earth, as well as the pictures of stars distant from us, millions of miles; it notes the course of the barometer and thermometer. The grandest works of art are rendered by it cheaply accessible, even to the poor, in copies inimitable in their fidelity, and by this means it becomes as important an agent in the culture of the people in the department of art, as is the art of printing in the domain of science.

But, although photography has made such advances, the development of its theory has not kept pace with the practice; certain as its different manipulations have become, we are just as uncertain in the interpretation of many of the physical and chemical processes taking place in them. Many attempts have indeed, been made in this direction, by Schnauss, Hardwich, Davanne, Girard, Monckhoven, and others; but still the theories hitherto proposed, do not suffice to explain all the mysteries and to settle the disputes which have lately arisen with regard to the nature of various photographic processes.

These circumstances have induced me to undertake a series of new experiments, and to repeat various experiments of former investigators. For three years I have been occupied in these researches, and in the present paper, I publish the first part of them. But, before passing to the experiments themselves, I must give a more exact account of the task which I set before me, and for this purpose, describe briefly, in the first place, the photographic manipulations which are now in use.

For the purpose of taking a picture, the photographer coats a glass plate with a thin film of collodion, impregnated with iodides and bromides (of potassium, sodium, lithium, cadmium, &c.); this plate is then sensitized, that is, immersed in a neutral or acidulated solution of 1 part nitrate of silver, in about 10 parts of water (the silver bath), and taken out again in about two minutes. The plate then presents a layer of collodion impregnated with iodide and bromide of silver and free solution of nitrate of silver. In this state it is put into the camera obscura, and exposed for a time to the light. The plate still shows no trace of a picture. This only makes its appearance, when an acid solution of sulphate of iron is poured over it, in the dark chamber. The sulphate of iron mixes with the silver solution adhering to the plate, and produces a precipitate of granularly pulverulent silver, which is deposited on those parts of the stratum of iodide of silver, which have been acted upon by the light, and thus renders the picture visible (*the so-called developing process*). The negative picture thus brought out, which consists merely of separate granules of silver (just as a lead pencil drawing of distinct granules of graphite), is now washed, and an acid solution of pyrogallic acid and nitrate of silver is poured over it; by this means a pulverulent precipitate is again formed, which is deposited upon the picture already existing, and renders this darker (*the strengthening process*). The picture thus obtained is washed; hyposulphite of soda is then poured over it, by which all the iodide of silver is dissolved (*fixing*), and it is again washed. In this condition, the picture forms a *collodion negative*, which is employed for the production of *positive pictures on paper*. For this purpose, paper soaked in common salt, and coated with white of egg or arrowroot, is floated upon a solution of nitrate of silver, and dried; the paper thus impregnated with chloride and nitrate of silver, is covered with the varnished negative, and exposed to the light. The light then shines through all the transparent parts of the negative, and gives the subjacent paper a brown colour; whilst the parts of the paper

* Poggendorff's "Annalen."

lying under the opaque portions of the negative remain colourless. In this way, is produced a positive picture, which is washed with water, put into a very dilute solution of gold, and finally fixed with hyposulphite of soda.

Of the processes here described very briefly, the scientific explanation of the process of exposure and of the action of the developing fluid was the problem that I set myself in the first place to solve; and here the following three questions arose:—

1. How does light act upon pure chloride, bromide, and iodide of silver?

2. What influence upon this action is exerted by foreign substances, such as water, acids, free salts of silver, organic bodies, &c.?

3. What change do the silver compounds which have been affected by the light, undergo during the so-called developing process?

The answering of these questions includes the answers to many others, which will come up in the course of the description of the following experiments.

1. How does light act upon pure chloride, bromide, and iodide of silver?

For the solution of this question many experiments have already been made, especially with respect to the chloride, fewer with regard to the iodide, and fewest in connection with the bromide of silver.

Scheele was probably the first (in 1777) to study the action of sunlight upon chloride of silver. He stated that chloride of silver blackens in the light of the sun, and leaves metallic silver when treated with ammonia; from this he concluded that it is decomposed in the sunlight into chlorine and silver. He further stated that under strong nitric acid it remains white.

A. Vogel and Wetzlar found, however, that blackened chloride of silver cannot be deprived of its colour by heating with nitric acid, and that by this means no silver is dissolved; from this they concluded that chloride of silver is decomposed by the sun's light into chlorine and subchloride (Schweigger's Journal, Bd. lii. p. 446).

Wetzlar, moreover, asserted, in opposition to Scheele's statement, that chloride of silver blackens even beneath nitric acid. Like Wetzlar, Wittstein found that no silver is extracted by nitric acid from blackened chloride of silver; and from this he also deduced the formation of a subchloride (Buchner's Report, Bd. xxxvi. p. 170).

Robert Hunt, on the contrary, maintains the formation of metal upon the surface of photographic paper impregnated with chloride of silver, as also the production of $Ag^2 Cl$ and of oxide of silver!

Guthrie (Chem. Soc. Am. Journ. x. p. 74) and Draper (Phil. Mag. xiv. p. 322) come to a different conclusion. They assert that the chloride of silver is decomposed into Ag and Cl. Guthrie thinks that the separated silver assumes a passive state, and is therefore insoluble in nitric acid. Draper says that, as nitric acid is incapable of dissolving any silver out of chloride of silver that has been exposed to the light, the free silver thus produced is endowed with such altered properties that one might believe in a transmutation of the metal!

Spiller (Humphrey's Journal, vols. xviii. and xix.)* affirms that, by the long-continued action of light upon chloride of silver, a body is produced the specific gravity of which is favourable to the notion that Ag Cl, when exposed to the light, is decomposed into Ag and Cl. Malone makes the same assertion. Starting from Faraday's opinion that the red colour of a solution of gold mixed with phosphoric ether is due to the suspension of red metallic gold, he thinks that a red and a brown silver may also exist, and supports his opinion by the fact that, when a solution of phosphoric ether is added to one of nitrate of silver, a brown fluid is produced resembling in colour papers impregnated with chloride of silver and rendered brown by exposure to light.

In order to ascertain the action of light upon chloride of silver, Dawson made a series of experiments. He exposed to the sun for three months bottles containing a solution of nitrate of silver to which he gradually added a dilute solution of chloride of sodium, and also other bottles with chloride of sodium, to which he added some solution of silver every day; he then washed the precipitates which had been rendered brown by the sun's light and boiled them with nitric acid. He found that the acid extracted silver from all the precipitates, without, however, essentially changing their brown colour. From this he concludes that the final action of light upon chloride of silver con-

sists in the formation of metallic silver. but that it previously passes through several intermediate stages, and that $Ag^2 Cl$, $Ag^3 Cl$, $Ag^4 Cl$, &c., were formed one after the other (*British Journal of Photography*, September, 1862).

Davanne and Girard likewise maintain the decomposition of chloride of silver into Ag and Cl, but do not support their view by any new facts (Davanne, "Chimie Photographique," 1861, p. 423.)

Hardwich, on the contrary, maintains the formation of a subchloride (Manual of Photographic Chemistry, 1863, p. 23).

These statements, to which I might add many others, show sufficiently how divergent are the opinions as to the change which chloride of silver undergoes by exposure to the light.

As to the alterations to which bromide of silver is subject is subject under the action of light, Berthier has stated that this substance acquires a pure grey colour, and blackens more slowly than chloride of silver (Poggendorff's Annalen, lxxvii. p. 417).

Monckhoven, on the contrary, asserts that it acquires colour more rapidly than chloride of silver; and he adds that the chloride becomes blue, and the bromide grey, on exposure to light (*Photographic Notes*, August 1862).

Iodide of silver has been the subject of fuller investigations. The change of colour of iodized silver plates was observed by Daguerre and others. Moser asserts that the iodized silver plates undergo no chemical change on exposure, and in proof of this cites an experiment made by Draper, who placed an iodized silver plate in the sun with moistened starch-paper, when the plate became dark green, but did not betray the smallest trace of free iodine (Poggendorff's Annalen, lvi. p. 190).

According to Moser, the entire change undergone by iodide of silver during exposure consists in its being blackened, and acquiring the property of condensing vapours of mercury. He also states that when the sun acts for a long time upon iodized silver plates, these again become pale (*loc. cit.* p. 185).

Schnauss has published some important investigations upon the part played by iodide of silver in photography (*Archiv der Pharmacie*, lxxiv. p. 1). He also supposes that iodide of silver is not chemically changed by the action of light, but that it only acquires the property of attracting reduced particles of silver by virtue of "a peculiar electrical tension." He proved that by means of iodide of silver alone no photographic picture can be produced, and that this was developed only by a precipitate of silver, which deposits itself on the exposed portions of the iodide of silver.

Subsequently he positively established, by experiment, what had long before been conjectured from various photographic processes, namely, that there are two modifications of iodide of silver—one sensitive, and the other non-sensitive; that the iodide of silver which is precipitated from a solution of silver by an excess of iodide of potassium is not sensitive to light, and that only that precipitated from an excess of silver solution is effected by exposure (*Photogr. Archiv*, 1860, p. 115). He says, iodide of silver of the latter kind becomes brown in the light. He seems, however, to think that iodide of silver owes its photographic properties only to the presence of a trace of nitrate of silver, which cannot be got rid of even by long washing. He regards the compound $Ag I + Ag ONO$, which may be obtained in a crystalline form from solutions containing iodide of silver, as the essentially sensitive body in the above described photographic processes (*Photogr. Nachschlagebuch*, pp. 144, 180, &c.). He also supposes that a chemical decomposition of iodide of silver, with elimination of iodine and formation of subiodide, takes place after long exposure (*loc. cit.* pp. 75 and 144). Sutton also maintains the indifference of iodide of silver prepared with an excess of iodide of potassium, and is opposed to its chemical decomposition. He supposes pure iodide of silver to be indifferent to light, and thinks that its sensitivity arises only from a trace of nitrate, which remains even after long washing (*Photographic Notes*, August, 1862.) [He thinks, however, that chloride and bromide of silver are reduced to silver with evolution of chlorine and bromine. Davanne asserts that iodide of silver is decomposed by light into iodine and silver (*Chimie Photographique*, par Barreswille et Davanne, p. 82). Hardwich and Monckhoven have combated this view with sound reasons (*Photogr. Archiv*, 1863, p. 79).

I have thus given a summary of the most important statements extant upon the changes produced by light upon the salts of silver, although I have by no means exhausted the literature of this subject, and many opinions not mentioned here will be

* Extracted from the PHOTOGRAPHIC NEWS.

discussed further on. I now pass to the description of the experiments which I have made for the solution of the question under investigation.

(To be continued.)

ANALYSIS OF THE SILVER SOLUTIONS USED IN PHOTOGRAPHY.

BY FRANCIS SUTTON.*

THE silver bath solutions for sensitizing collodion and paper frequently require examination, as their strength is constantly lessening. To save calculation, it is better to use an empirical solution of salt than the systematic one previously described.

This is best prepared by dissolving 43 grains of pure chloride of sodium in 10,000 grains of distilled water; each decem (=10 grs.) of this solution will precipitate 0.125 grn. (i. e. $\frac{1}{8}$ grn.) of pure nitrate of silver; therefore, if 1 fluid drachm of any silver solution be taken for examination, the number of decems of salt solution required to precipitate all the silver will be the number of grains of nitrate of silver in each ounce of the solution.

Example:—One fluid drachm of an old nitrate of silver bath was carefully measured into a stoppered bottle, 10 or 15 drops of pure nitric acid and a little distilled water added; the salt solution was then cautiously added, shaking well after each addition until no further precipitate was produced; the quantity required was 26.5 dm., = 26½ grains of nitrate of silver in each ounce of solution.

Crystals of nitrate of silver may also be examined in the same way, by dissolving (say) 30 or 40 grs. in an ounce of water, taking 1 drachm of the fluid and titrating as above.

In consequence of the rapidity and accuracy with which silver may be determined when chromate of potash is used as indicator, some may prefer to use that method. It is then necessary to have a standard solution of silver, of the same chemical power as the salt solution; this is made by dissolving 125 grains of pure and dry neutral nitrate of silver in 10,000 grs. of distilled water; both solutions will then be equal, volume for volume.

Suppose, therefore, it is necessary to examine a silver solution used for sensitizing paper. One drachm is measured, and, if any free acid is present, cautiously neutralized with a weak solution of carbonate of soda; 100 dm. of salt solution is then added with a pipette; if the solution is under 100 grs. to the ounce, the quantity will be sufficient. Three or four drops of solution of chromate of potash are then put in, and the silver solution delivered from the burette until the blood-red colour of chromate of silver is just visible. Suppose that 25.5 dm. have been required, let that number be deducted from the 100 dm. of salt solution, which will leave 74.5 dm., or 74½ grains to the ounce.

This method is much more likely to give exact results in the hands of persons not expert in analysis than the ordinary plan by precipitation, inasmuch as with collodion baths, containing as they always do iodide of silver, it is almost impossible to get the supernatant liquid clear enough to distinguish the exact end of the analysis.

Recent Patents.

APPARATUS FOR TAKING PANORAMIC PHOTOGRAPHS.

THIS specification of invention by J. R. Johnson and J. A. Harrison, was sealed in March 1863. We give the provisional specification, the final statement being too lengthy and elaborate for our columns.

Our invention consists of certain improvements in the apparatus for taking panoramic pictures. It is well known that if a photographic lens be mounted vertically upon a pivot, the centre of which coincides with a vertical line drawn through

the true centre of the lens, and if such lens be made to turn upon the pivot, the images of the objects which are brought in succession in front of the lens during its revolution may be projected upon a screen placed behind the lens, and if such screen be part of a cylinder, the radius of which is equal to the focal length of the lens for the images so projected, and the centre of which coincides with the centre upon which the lens turns, such images are true representations of the objects, and remain stationary upon the screen, notwithstanding the motion of the lens; cameras thus constructed have been used for producing panoramic pictures upon curved daguerrotype plates. It is also known that if instead of the curved plate for receiving the images a flat plate be employed, and if while the lens and the base upon which it is mounted and which carries the plate revolve, the plate be made to traverse in the opposite direction, with due relation to the rotation of the lens, the images projected upon the plate are likewise stationary; cameras formed upon this principle have been suggested for the production of panoramic views, but so far as we are informed have not come into practical use. Now, the object of our invention is to render both the above-mentioned forms of camera fit for use with the modern process of photography.

Our improvements consist, 1st, of an improved construction and arrangement of the parts of the flat plate camera, so that their motions are smooth, equable, and free from vibration, and so that the whole apparatus is rendered more compact and portable.

2nd, Of a new mode or modes of obtaining the relative motions of the lens and sensitive plate, such motion being obtained directly by mechanical means, instead of forming "guide curves" by trial, as has before been proposed to be done.

3rd, Of an improvement in the gearing when working both forms of camera.

4th, Of the application of a spring or falling weight to give the motion to such cameras, and of means for regulating the motion both at variable and invariable rates.

5th, Of an expanding diaphragm to regulate the exposure in cameras moving at an invariable rate.

6th, Of an expanding diaphragm to be placed between the lens and picture, by means of which sky and cloud effects may be obtained.

In effecting our first improvement we render the camera symmetrical and duly balanced by placing the lens in its centre instead of at one side, and placing the rollers or other support upon which it rotates at equal distances on each side of the centre, and upon the circumference of a circle whose centre coincides with the centre of the pivot upon which the apparatus turns, so that the space travelled over by each roller is equal, and the resistance consequently equal. The plate-holder slides within the camera instead of through its side.

In its simplest but least compact form, the camera is an oblong box placed upon a plate or bed upon which the rollers revolve, as shown in the diagram No. 1, in which the dotted lines indicate the plate-holder and its line of motion, and also the motion of the rollers upon the bed. It will be seen, therefore, that the whole apparatus has a motion of rotation round the pivot placed under the centre of the lens, while the plate holder has a motion of translation from one end of the camera to the other. We render the camera light and more compact by dispensing with the vacant space, as shown in the diagram No. 2, the dotted lines indicating the condensed form. The camera proper then assumes very small dimensions, the necessary length for the traverse of the plate being obtained by a tube or narrow box attached to the back of the small camera; the weight may be still further reduced by substituting a plate or thin board for the tube just described. The plate-holder slides upon the plate, which acts at the same time as a dark slide, see diagram No. 3. We can still further limit the dimensions of the apparatus by shortening this plate, and letting the plate-holder overhang or extend beyond the back plate at each end, in which case provision must be made for shutting out the light, which may be effected by a strip of india-rubber cloth or oiled silk passing over rollers, see diagram No. 4, placed at each end of the plate-holder.

2nd, We obtain the relative longitudinal motion of the plate to the rotary motion of the lens and camera, when a flat plate is used, by a toothed wheel fixed on the bed or plate, upon which the camera turns, gearing into a rack attached to the plate-holder; but to obtain this effectually, the wheel must be wholly or partially within the camera, or the plate-holder must

* From *The Handbook of Volumetric Analysis*, by FRANCIS SUTTON.

slide outside, as in that form of camera previously described and shown by diagrams 3 and 4. By this modification of the apparatus the motion is obtained in a direct manner, and the necessity for the trials or experiments to form the guide curves is dispensed with, as is also a large amount of friction from the rollers which act upon the curves. We find, however, that a much smoother and more equable motion is obtained by employing a fixed disc or pulley instead of a toothed wheel; a cord or strap is attached at one end to the disc, and at the other to the plate-holder. As the camera revolves, the cord or strap winds upon the edge of the disc, drawing forward the plate-holder for a distance equal to the segment of the arc of the circular edge of the disc upon which the cord or strap has wound itself. Or the cord or strap may be attached at each end to the disc respectively, and be passed over from rollers, as shown in the diagram No. 5. The plate-holder is fastened to the cord or strap, and slides backward or forward according to the direction in which the camera carrying the rollers rotates.

3rd. Our third improvement consists in adding a fly wheel or other regulator to the gearing for working panoramic cameras, by which a greater uniformity of motion is produced.

4th. In order to obtain definite exposure with wet collodion or other quick-acting processes, especially in obtaining the so-called instantaneous pictures, we find that the due rapidity and equality of motion cannot be obtained by hand. We therefore adapt a spring or weight to move the apparatus. With a weight or spring the rate of motion may be made invariable or variable. We obtain an invariable motion by a fly-wheel escapement, or by any other mode of obtaining motion at a fixed rate. In this case it is necessary to adjust the rate of exposure by the amount of light admitted; to effect this we form an expanding diaphragm by making openings in two plates of metal having motion in opposite directions by means of a right and left-handed screw, or otherwise. In one position the openings on the plates coincide, and the full aperture is obtained; but when moved in opposite directions the resulting opening becomes reduced, and at last closed. The diaphragm thus formed is placed within the tube of the lens, and by this means any amount of aperture within certain limits may be given, and the amount of light adjusted. A variable motion may be given to the apparatus proportionate to the amount of exposure required by a fly or vane, the arms of which may be set at a varying angle, or by other known modes of adjusting motion; we prefer, however, for this purpose a tube or small cylinder fitted with a piston, the two ends of which are in communication by a pipe; the rod of the piston passes through a stuffing box, so that the tube may be kept full of water, or any other fluid. A cock or valve is placed within the pipe which joins the two ends of the tube or cylinder, by adjusting the cock or valve the aperture may be increased or diminished at will, and thus the rate of the passage of the fluid from one end of the tube to the other under an equal pressure of the piston, and consequently the rate of motion of the latter may be regulated; such a regulator may be attached directly to the string of the falling weight, or by a rack fixed to the end of the piston gearing into a toothed wheel attached to the pulley over which the cord passes. Any rate of motion may be thus obtained.

5th. We fix a diaphragm between the lens and sensitive plate close to the latter, as in the curved plate camera. We render this opening of the diaphragm variable by forming it of superposed plates of metal which slide over each other, so that the form and size of the opening may be changed at will.

Proceedings of Societies.

NORTH LONDON PHOTOGRAPHIC ASSOCIATION.

The usual monthly meeting of this Society was held on the evening of Wednesday, the 21st, in Myddelton Hall. Mr. G. SNABOLT in the chair.

The minutes of a preceding meeting having been read and confirmed, the following gentlemen were elected members of the Society:—Messrs. G. Cartland, jun., A. Saunders, and H. P. Clements.

Mr. Dawson stated that the sub-committee for selecting the presentation print had communicated with Mr. Wilson, but owing to his arrangements with his publishers, Messrs. Marion and Co., he was unable to treat directly with them. On

applying to Messrs. Marion and Co., Mr. Bishop, of that firm had met them in a most handsome spirit, offering a couple of the $7 \times 4\frac{1}{2}$ prints at the mere cost of printing and mounting; and to avoid delay, allowed them to select from their stock the full number they required. The prints were on the table for members to make a selection of two copies each.

A choice selection of Wilson's well-known cabinet photographs were produced, and distributed to the satisfaction of every one.

A vote of thanks to Messrs. Marion was passed by acclamation.

The CHAIRMAN exhibited one of the new albums by Marion and Co., filled with Mr. Wilson's charming album views.

Mr. Dawson exhibited a number of pleasing and artistic card portraits, chiefly of children, illustrating the power of photography to secure expression, by Messrs. Ross and Thompson, and some pleasing studies of larger size by the same artists.

Mr. F. W. HART exhibited his apparatus for estimating the amount of precious metal in the salts or solutions used in photography, and illustrated its working. It consists of a burette, something like Mohr's alkalimeter, the markings dividing it into sixteen equal parts, the whole containing exactly one ounce avoirdupois or $437\frac{1}{2}$ grains. The burette is furnished with a compression stop-cock of vulcanized india-rubber, permitting the dropping of the solution to be easily regulated. The clip or pinch-cock is an improvement, in simplicity and efficiency, upon Mohr's. The burette is provided with a convenient support or stand. A sealed tube is filled with an accurately-weighed portion of pure dried chloride of sodium, which when added to eight ounces of distilled water, measured in the burette (ordinary graduated measures rarely being accurate), gives the test solution. A pipette, holding one drachm, is provided for drawing from the stock bottle of nitrate of silver solution an accurately measured drachm. This is placed in a larger vessel, and added to about six times its bulk of distilled water, together with a few drops of nitric acid. An ounce of the test solution is now placed in the burette, and a portion of its contents dropped into the silver solution to be tested. If one division of the burette be emptied in precipitating the whole of the silver as a chloride, the solution has contained 8 grains to the ounce; two divisions, 16 grains to the ounce, and so on in proportion. The illustration of the method of estimating the amount of silver in a given sample of waste was as follows: a sample of 15 grains of dried waste, purporting to be chloride of silver, was placed in a test tube with an equal weight of pure zinc; upon this was poured about a quarter of an ounce of dilute sulphuric acid, one part of acid in eight of water. The nascent hydrogen formed by the decomposition which followed uniting with the chlorine, threw down the silver in a metallic form. When this operation was completed, and the silver well washed, the addition of dilute nitric acid converted the silver into nitrate of silver, which was tested in the manner above described, and was found to yield $9\frac{1}{2}$ grains of nitrate of silver, which, containing about 63 parts in each 100 of pure silver, gave about 6 grains in the sample of waste tested. The burette, support, test-tube, box of pure zinc, tube of pure chloride of sodium, &c, all packed neatly into a small mahogany box.

Mr. HARMAN, in accordance with a promise given at the last meeting, produced a series of prints from the same negative, printed on paper excited on silver baths of different strengths. The paper was prepared expressly for the purpose by Mr. Hart, with pure undiluted albumen, containing eight grains of salt to each ounce. The negative which was produced was one of moderate quality. The first two prints were floated for 10 minutes, one on a 10-grain nitrate bath, and the other on a 20-grain nitrate bath; the next for 5 minutes on a 40-grain bath; the next for 3 minutes on a 60-grain bath; the next for 2 minutes on an 80-grain bath; the next for 45 seconds on a 100-grain bath; the next for 15 seconds on a 120-grain bath; and the last for 5 seconds on a 160-grain bath. A progressing increase in vigour and richness was found up to 80 grains; beyond that, the results seemed doubtful. He also exhibited some prints from the same negative, excited on a 20-grain bath, containing 60 grains of nitrate of soda, according to the formula suggested by a correspondent of the PHOTOGRAPHIC NEWS, six months ago. These were equal to the best of the others. All the prints were exposed in sunlight on the same day, and subjected to the same treatment in toning and fixing. Those excited on the weak solutions of simple nitrate were slower in printing and lost

more in toning and fixing than the others. Those which received long floating showed the image right through the paper whilst wet, whilst the others having the imago more confined to the surface did not do so. Those floated on the very weak bath seemed to show that a portion of the albumen was dissolved.

The CHAIRMAN remarked that the results appeared certainly in favour of the strong solutions, but what were the commercial results?

Mr. HARMAN said that if the residues were carefully saved, there was not much loss by using strong solutions.

The CHAIRMAN said the results precisely agreed with the opinion he expressed in the printing committee years ago. Then as to the use of the two salts, what was Mr. Harman's conclusion?

Mr. HARMAN said the process must be a great advantage if a 20-grain silver bath gave results equal to a 60-grain silver bath.

The CHAIRMAN remarked that since there was not a less actual expenditure of silver there was not much advantage, as the bath would only require renewing so much more frequently.

Mr. WHARTON SIMPSON said that the recovery of silver from residues always involved some actual waste besides the trouble, and therefore all the free silver that could be dispensed with effected some saving. But, as it often happened that amateurs did not save their washing water, &c., the saving to them would be considerable, besides involving less expenditure at the outset, a consideration where large baths were necessary.

Mr. HISLOP had felt the question to be a very important one when he last month called attention to it, and to amateurs it was of vital consequence. He had often thought that the subject had been treated in a dogmatic manner without careful examination, and he thought that the specimens brought before them proved that a great deal too much stress had been laid on the importance of strong nitrate baths, for there was, after all, but very little difference between the prints produced by the weakest and by the strongest bath described; certainly not nearly so much as between the various strengths employed; whilst, when nitrate of soda was employed, the difference quite disappeared. Then as to the question of waste, as Mr. Simpson had very properly put it, amateurs were especially concerned. They rarely saved their waste; they had not the appliances for doing so economically. Their printing was done at odd times, now a little and then a little, and often put aside altogether for a time. He had been led to examine the subject by some recent observations by Mr. Taylor, and he found on experiment that good prints could be produced by the aid of solutions much weaker than those generally said to be imperative for good results. The bath must, of course, be strong enough to decompose the chlorides; but the great excess of free nitrate was, he felt convinced, unnecessary. The question was, how much nitrate of silver was necessary to produce the necessary changes. They had not yet got to that result, but he thought it was established, that with proper care good prints could be produced by a much less expenditure than formerly, and he thought few would continue to make baths of the old strength, if one with several ounces of silver less would do. He thought his views had been amply confirmed by the specimens produced.

Mr. HARMAN thought there was all the difference in the prints he had produced, between bad and good.

Mr. HISLOP did not see this; he thought none very good.

Mr. HARMAN said the negative was not very good; but the best prints were as good as could by possibility be produced from the negative.

A desultory conversation ensued on some vigorous prints, produced by Mr. Hislop with a weak bath, and on the methods of printing weak negatives, &c.

Mr. DAWSON produced some prints taken with a view to test this subject. The paper was prepared expressly for the purpose, 12 grains of chloride of ammonium being used to each ounce of albumen; thin Saxe, medium Saxe, and thick Saxe, each being tried on various baths ranging from 30 to 90 grains. There was a decided progressive improvement in depth and vigour in those excited on the strong baths. With the thin Saxe, however, no improvement was observed after passing a strength of 60 grains; whilst, with the thick Saxe, the best results were obtained on the 90-grain bath. Those excited on the 30-grain bath require five times as long to print as those on the 90-grain bath. He had also tried nitrate of soda, using a 45-grain silver bath; he found no difference whatever in the prints produced with that bath and with a portion of the same solution without

the nitrate of soda, and both were inferior to those from a stronger bath. As to time of floating, he found that with the thin and medium Saxe a short floating on a 60-grain bath was better than longer; whilst, with a thick paper, five minutes was better than two minutes. With thin flat negatives he used a weak solution, and printed in the shade.

The CHAIRMAN and Mr. SIMPSON both remarked that for weak negatives they would use a strong solution, and print in the shade, and for hard negatives, use a weak solution, and print in the sun.

A conversation ensued as to the precise meaning of the term weak negative, and some other matters, and the subject was dropped.

Mr. SWAN exhibited some of his new crystal miniatures and the Chairman explained to the meeting the principle upon which they were produced, as described in Mr. Swan's paper at the British Association. After some conversation on the subject,

Mr. MARTIN exhibited some fine photographs of Balmoral, and other Scottish scenery, and portraits of the Prince and Princess of Wales, taken by Mr. Stephen Thompson. The collodion was Horno and Thornthwaite's bromo-iodized, the lens for the landscapes, Dallmeyer's triple, and for the portraits, the No. 1 B. of the same maker.

The CHAIRMAN exhibited some of Mr. Bourno's photographs, taken in the East, and a specimen of Mr. Dallas's photo-electric engraving.

Mr. COLLIS, of the firm of Ottowill and Co., exhibited a clever and well-made repeating camera for medallion portraits, taking twelve negatives with four lenses.

Mr. W. W. King promised a paper on the tannin process for the next meeting.

The proceedings then terminated.

Correspondence.

FOREIGN SCIENCE.

[FROM OUR SPECIAL CORRESPONDENT.]

Paris, October 28th, 1863.

PHOTOGRAPHS in their natural colours! This dream of the ardent photographer has been realized by M. Charlot Plé; that is, if the news be true. Be that as it may, M. Plé is committed to the fact of the discovery, for the Minister of Public Instruction transmitted to the Academy, at its sitting of the 28th ult., a note from M. Charlot Plé, concerning the discovery of a substance which permits the obtaining photographic pictures, *reproducing the colours of the objects represented*. This note, however, does not make known the composition of the bath into which the paper is immersed to impart the properties claimed for it, and therefore the Academy has no means of proving the truth of this discovery. The author of it, it is true, offers to give, if desired, all the necessary details, and, at the same time, some proofs obtained by his process. It would have been much more satisfactory, if he had done so at once, without waiting to be asked. Before the Academy appoints a committee of inquiry, M. Plé will have to give satisfactory evidence of the integrity of his discovery.

M. Balsamo, professor of physical science at Lucca, has communicated to *Cosmos* the composition of a new bath for positives. He says:—"The employment of the salts of gold has now become very general in photography; we know that the effect of their action is to transform the pale tints the positives, obtained by salts of silver possess upon leaving the fixing bath, into artistic tones.

"Operators have long endeavoured to compose toning baths with the salts of platinum and mercury, which would permit a variety in the hues of the proofs. None of these baths give the velvety tint peculiar to the salts of gold, and so agreeable to the eye. I have been induced to study the characteristics of the salts of bismuth employed as toning baths, and I have obtained, especially with the nitrate of bismuth, proofs with very fine tones, the hue of which may be compared with that of the skin of the chestnut. This toning bath deeply penetrates the blacks of the proof,

leaving the half-tones transparent. There is an important precaution to be observed in practice, as is well known, the nitrate of bismuth produces, with water, an insoluble sub-salt, which alters the proofs, if it be not dissolved by means of acetic acid, which does not injure the delicacy of the proofs.

M. Balsamo adds, that by varying the manipulations of his process, he can obtain a great variety of hues, imitating crayons. The proofs have undergone no change during the two years that have elapsed since they were printed. Two new metals have recently been discovered. One by MM. Reich and Th. Richter, in the arsenical pyrites of Freybourg, to which they have given the name of *indium*, because there is no green ray in its spectrum; but, on the contrary, an indigo blue ray, which hitherto has not been seen in the spectra; it is very brilliant and clearly defined, and very persistent, with a refrangibility much greater than the blue ray of strontium.

The other new metal has been discovered by a Swedish chemist, M. Bahr, in a mineral resembling orthite, found in the isle of Roensholm. He has given it the name of *wasium*, and the mineral he calls *wasite*. It does not appear that it gives characteristic spectral rays.

M. Soulier, partner of M. Ferrier, has added 200 more stereoscopic views in Switzerland to his already large collection, numbering now over 5,000 views. The new series depicts the scenery of the cantons of Lucerne, Unterwald, Uri, Tessin, the Grisons of Saint Gall, Thurgovia, the duchy of Baden, and the Tyrol.

Paraffin possesses certain properties which render it useful in the laboratory. It may be advantageously substituted for oil in baths, as it endures a high temperature without evaporating or emitting any unpleasant odour. Filtering paper, after being soaked in it, may be kept several weeks in concentrated sulphuric acid without undergoing the slightest alteration. From this property of paraffin it may be advantageously applied as a coating to labels on bottles containing strong acids: fluoric acid even does not act upon it, except it be heated. Paraffin appears also to be useful in preserving fruits. Apples, pears, &c., coated with it retain all their freshness during several months.

Recent analysis of the water of the Dead Sea show the presence of an extraordinary quantity of bromine, nearly $\frac{1}{2}$ grains in every ounce of water; and if ever a large demand for bromine arises, an inexhaustible supply presents itself in the waters of this great lake.

PHOTOGRAPHY IN COLOURS.

Canandaigua, New York, Oct. 10, 1863.

MY DEAR SIR,—Yet in the country, I cannot be expected to write you any news from the photographic world. I am immensely busy about these times, in an extensive investigation of the manner in which gentlemen having nothing to do spend their time. I fell over a waterfall fifteen feet high, a short time since, and in consequence of a dislocated jaw-bone and a disabled arm, have been prevented from photographing since; so I take long walks sometimes, and feel lonely without my camera. Lying flat on my back on a log in the wild woods on a sunny afternoon, when I had walked some miles away from home, I fell to ruminating on the vicissitudes and uncertainties of our art. A chip-squirrel pranced along a limb over my head with a huge butternut in his paws, and disturbed a bright red leaf, which fluttered and whirled around, till, at last, it settled on my nose. Too lazy to brush or blow it off, I looked at its transparent colours. I looked at the gorgeous trees above me, and at the varied hues of the woods in the swamp at the foot of the lake. "Oh!" cried I, in a sudden paroxysm of earnest feeling, which frightened the chip-squirrel off his perch, and made him drop his nut; "Oh! for the man who can photograph in colours."

Our forests in America are gorgeous in October. Yes,

they are *gorgeous*, and this word only approximates to an idea of their many-coloured hues. The shade most predominant, perhaps, is flame colour, or "magenta." Then comes the rich yellow and scarlet of the maples; the "Sauds of Sahara" shade of the beeches; the deep brown of the oaks; the red of the creeper vines; all backed up with the deep green of the cedars and pines, or the still verdant chestnuts which are among the last to change. Oh! for the undiscovered art, Chromatic Photography! "Pshaw," said I, as I closed one eye, and looked at the poor worthless maple leaf with the other; "Pshaw, what is photography if it cannot picture this one miserable leaf, which we trample under foot!"

I puffed the leaf spitefully away, and flopped myself off the log, resolved to return home and punch out both the eyes of my camera, and empty all my chemicals in the street gutters.

Mr. Editor, where is the genius of man? If we can call the sun to draw out for us all the forms and shapes of both art and nature with more accuracy than our own hands can do it, why can we not induce him by liberal drafts on chemistry, to reproduce colours? Let all the "irrepressible experimentalists" of the whole photographic world bend their energies to this one end, and let there be no rest until it is attained. For until this can be done, we are but as the caterpillar of the dirty path, and we cannot yet understand the brilliantly coloured butterfly state, to which we must at some time arrive. Hoping some lucky and patient professional or amateur will soon publish to the world a short and easy formula for taking *instantaneous* impressions on dry plates, comprehending all the natural colours; and feeling confident that some such man is going to soon turn up, I will postpone the demolition of my apparatus for the present.—Yours respectfully,
F. F. THOMPSON.

CHEAP BATTERY FOR THE ELECTRIC LIGHT.

SIR,—In the last number of your valuable paper, I see the electric light mentioned as having even greater actinic powers than the sunlight, but the immense cost of such a combination of cells as is mentioned, renders their use in practical photography impossible.

Now, there is a way to produce an electric light with one cell only, but having the intensity of 20 to 30 cells, by means of the Ruhmkorff Induction Coil. The cost of this light would be about 3d. per hour. I am not aware that any experiments have been made to find out if this light can be made useful for photography; from what I have seen of the light, I should think it might be useful for printing at least, possibly even for portraiture, and might in this case become very valuable to the London photographers in the approaching season of dullness.

I may mention that the cost of the whole apparatus would be £6 to £8, I think.

If any of your readers should like to make experiments, I shall be happy to give the address of a maker of batteries and coils, where they may be got cheap—possibly, for the first experiment, on hire.—I remain, Sir, yours truly,

London, October 27th, 1863.

ARGENT BISCH.

Photographic Notes and Queries.

FRAUDULENT CHLORIDE OF GOLD.

SIR,—From the enclosed, you will see that I am a maker of photographic chemicals, and I beg to address you on a subject which deserves consideration, viz., the article chloride of gold for toning. Feeling convinced, from the many valuable hints you give to photographers, that it is your study to assist them with all useful information.

I have noticed for some time that many artists, after giving a tube with full weight of fine dry crystals of chloride of gold "a fair trial," pronounced it not better than a tube of moist salt, which was evidently adulterated with soda. I was always

convinced that the judgment of such artists was at fault, but I was not aware that the adulterations of the above article were as extensive as they really are, according to the October number of the *Pharmaceutical Journal*, which I beg to send you, and from which you will see that there is a very large proportion of gold tubes in the market, warranted to contain 7 grains of gold, but which contain only about 5 grains.

Now, if a photographer cannot find out the difference between a tube containing 5 grains, and another containing 7 grains of gold, his manipulation must be wrong, and he must waste about one-half of the contents of the latter tube, which waste must amount to a pretty large sum in a year.

I therefore think that you would deserve the thanks of artists by giving them a method of managing their toning baths, by which they would use all the gold a tube contains. By enabling them to find out where an honest article is sold, you would earn the thanks of those makers of chloride of gold, who will give honest weight, by putting an end to a dishonest practice of forcing the trade by spoiling prices, and adulterating so costly an article; besides, the dealers would soon have to look a little for an honest article in buying, instead of buying only what is offered at the cheapest price.—I remain, Sir, yours truly,

AUGUST BUSCH.

London, October 23, 1863.

[Without a careful analysis, the photographer cannot obtain absolute certainty as to the freedom from adulteration of his chloride of gold. He may form some judgment by its appearance, the pure salt generally being of an orange tint, crystalline, and readily deliquescent. Adulterated samples are generally lighter in colour, dryer, and less crystalline, tending rather to granulation. A practised printer, using a good toning process, will find by the quantity of prints toned, if there be a serious deficiency of the precious metal in the salt, which professes to be its chloride; but the desultory operations of amateurs and those doing little printing, do not enable them to form an accurate opinion in this way. Those who use much carbonate of soda in the bath generally lose a great deal of gold, as the toning bath becomes inert long before it is exhausted. Probably the apparatus for facilitating volumetric analysis, which Mr. F. W. Hart is just introducing, may enable photographers readily to estimate the real amount of gold.—Ed.]

PERAMBULATOR TENT.

DEAR SIR,—While down at the island, with the camera, I have seen a contrivance which I thought of some time ago, well carried out, viz., a portable tent to carry everything *in se ipso*; and I thought it might be as useful to some of your readers as it has proved to be to myself. It consists, primarily, of a large deal box, with lid, about 3 feet by 2 by 1½ deep, mounted on 3 wheels, à la perambulator. Four slim iron rods are inserted (screwed) into the four corners of the lid, and on the top of them four others are secured horizontally, so as to form a frame like a four-post bed, to which the drapery hanging down to the bottom of the box enhance the similitude. The cover is fastened round the box by means of a strap in a groove. The yellow window is in one surface of the cover, and a bag-shaped aperture, with a string to keep it round the waist of the operator, in the other. The bath, if large, goes into an aperture of the lid. The whole forms a very handy dark room, and the box carries everything, including a small *oil-can* for water. I borrowed this machine, and have got some very good negatives—some instantaneous. *In re* lenses, I have had the opportunity of comparing as to rapidity, three varieties, with this result: Dallmeyer's No. 1 B, quickest; my own Dallmeyer's stereo (double), next; another English maker, last; a half-plate Jamini, nowhere.

I took a fully done negative of a house with foliage, the other day, in three seconds with my No. 1 triple; is that up to par? With thanks for past favours, yours very gratefully,

Ile of Wight.

G. A. BEECROFT.

Talk in the Studio.

PHOTOGRAPHIC SOCIETY.—The first meeting of the winter session will be held on the evening of Tuesday next. A communication will be read from Mr. Sutton, "On Rapid Dry Plates," and a paper by Mr. Smith, of South Kensington Museum, "On the Photographs of the Last Century."

ROYAL PORTRAITS.—Mr. Wilson, of Aberdeen, recently had the honour of a summons to Balmoral, and there secured several portraits of Her Majesty and of several members of the Royal Family.

PHOTOGRAPHIC PROPERTIES OF THALLIUM.—Mr. Crookes has recently discovered some curious photographic properties of thallium, of which we shall shortly publish particulars.

MR. STUART'S IMPROVEMENTS IN THE SOLAR CAMERA.—We have received from Mr. Stuart, of Glasgow, a model of his improved apparatus for working the solar camera without a mirror, and the description of its working read before the Glasgow Photographic Society, which will appear in our next.

GLASGOW ART UNION PHOTOGRAPHS.—Mr. Anuan has just completed a very beautiful series of photographs of drawings, by Noel Paton, for distribution to the subscribers to the Glasgow Art Union. We shall notice them in detail in our next.

FRAUDULENT CHLORIDE OF GOLD.—At a meeting of the recently founded British Pharmaceutical Conference, Mr. Reynolds called attention to several glaring cases of adulteration, one of which had reference to chloride of gold. Referring to a former paper on the subject (see *PHOTOGRAPHIC NEWS*, p. 23. vol. v.), he said that such frauds continued. The tube exhibited had contained such a salt. It was about three and a half inches long, was wrapped in green paper, and had a red label, "Chloride of Gold, 15 grains." The actual weight of the contents was 14.05 grains, but it only yielded 5.1 grains of pure gold instead of 7 grains, which it ought to have done. He had again examined some made by a firm who guaranteed 7 grains of gold in the bottle, and found precisely that amount. He had been confirmed in the belief that "honesty is the best policy," by what this firm had told him, viz., that when they adopted the principle of a guarantee, their sale for the article multiplied by ten in a very short time.

SELF-ACTING WASHING PAN.—Messrs. Bull Brothers have recently introduced an automatic washing apparatus, intended to secure the most perfect washing of prints at the least cost of water, time, or superintendence. It consists primarily of a zinc trough, with a second bottom of perforated zinc, resting about an inch from the bottom of the outer vessel, to prevent the prints ever resting in the lowest, and, consequently, most saturated with hypo, stratum of the water. The supply pipe is so curved and flattened at the aperture that the stream of water comes in with sufficient force and in the right direction to give to the prints a continued rotary motion. A self-acting syphon, the tube of which is of larger diameter than the supply tube, is attached, and comes into action as soon as the trough is full. By this means the trough is completely emptied at given intervals of, say, ten minutes or a quarter of an hour. This done, the action of the syphon ceases, the trough again fills, all the time whirling round the prints and keeping them in constant agitation; again empties, and again fills, and so on as long as the supply of water continues. It must be obvious that a much more thorough washing is thus effected in three or four hours than by six times as long soaking in still water, with slow changes. The whole affair is neatly fitted up, and, we believe, moderate in price.

ROMANTIC MARRIAGE.—PHOTOGRAPHY MADE USEFUL.—We find the following in a provincial paper published ayont the Tweed.—"A young lady correspondent favours us with a communication which we find to be quite true, and which proves beyond question the fact of the old adage that 'truth is stranger than fiction.' The narrative is too long to insert *in extenso*, but we may give the following summary without mentioning names. It would appear that a gentleman in the ancient metropolis 'The kingdom' had a friend residing in the capital of the dominions of the Grand Turk, and to this friend he some time ago forwarded a few *cartes de visites* of mutual acquaintance and relations. Among other likenesses thus forwarded was one of a good-looking young lady of about eighteen. We can easily conceive how desirous all the acquaintances of the fortunate possessor of the Scottish *cartes* became to inspect them, and the numerous criticisms expended on the collection. One gentleman friend, however, said little but thought much, and the result of his cogitations was the falling over head and ears in love with the portrait of the young lady of eighteen. What was to be done? He could not rest; he could not sleep; he must secure her for a wife; and, most certainly, he concluded if he did not hurry she would be lost to him. She looked so pretty. He quickly made his arrangements; and although he did not swim the Bosphorus like Leander of old, he quickly

engaged a passage in the first steamer and turned his face homewards. Arrived in the country of his nativity, he quickly found his way to a celebrated city in the 'Kingdom of Fife,' where the young lady dwelt with an uncle, and lost no time in calling. The young lady was absent at a 'cookie shine,' but on declaring the object of his visit, and making a proposal in duo form, the young lady was sent for, and speedily met her unknown lover. Notwithstanding the extreme ardency of his affection, he gracefully allowed her two hours to consider of the matter, at the end of which lengthened period she condescended graciously to consent to his proposal; and the marriage, we are informed, will be celebrated. Hooray! Hooray!"

VALUE OF A BROMIDE.—From a paper read at the British Association, by Dr. Gibb, on the physiological effects of bromide of ammonia, it appears that it aids in producing soft tempers as well as soft negatives. Its properties were thus summed up:—1. In small doses, more or less continued, bromide of ammonium acts as a tonic and absorbent, and exerts its peculiar properties upon the skin and the mucous membrane. 2. It diminishes the weight of the body, causing the absorption of fat, when continued with a regulated diet. 3. It improves the intellectual powers, increases the bodily capacity, and promotes healthy function. 4. Locally it possessed a soothing influence on the mucous membrane, and according to the strength and mode of its application, so does it diminish the sensibility. 5. In large frequently repeated doses, or given at intervals, it influences the entire mucous tract, affects all the special senses, and produces impaired sensibility of the various mucous outlets. 6. All the poisonous effects are produced by very large doses, as from the bromide of potassium, but in smaller doses it is more certain and reliable, causes no diarrhoea or diuresis, nor anaphrodisiasis, and its special properties are exerted sooner and with less inconvenience. The President said if Dr. Gibb's researches resulted in the discovery of something to improve the temper, it would be very important. If he knew that Dr. Gibb's conclusions were well worked out, he would not go without this bromide for the improvement of the temper. (Laughter.)

CHEMICAL DANGERS.—M. Rouelle, an eminent chemist, was not the most cautious of operators. One day, while performing some experiments, he observed to his auditors, "Gentlemen, you see this cauldron upon the brasier; well, if I were to cease stirring a single moment, an explosion would ensue which would blow us all in the air." The company had scarcely time to reflect upon this comfortable piece of intelligence before he did forget to stir it, and his prediction was accomplished. The explosion took place with a horrible crash: all the windows of the laboratory were smashed to pieces, and two hundred auditors whirled away into the garden. Fortunately none received any very serious injury, the greatest violence of the explosion having been in the direction of the chimney. The demonstrator escaped without further injury than the loss of his wig.

[ADVERTISEMENT.]

CHAPPUIS'S PATENT REFLECTORS, for photographic purposes. These reflectors, generally used in dark warehouses, ships, apartments, &c., are now applied to photography.—P. E. Chappuis, patenteo and photographer, 69, Fleet-street.

To Correspondents.

A BEGINNER.—If you are working in the field it is sometimes a great saving to put the plates away without fixing or intensifying. They may then be fixed and intensified at leisure. It is better in such case to fix before intensifying, and for that purpose perhaps cyanide is best, as being more easily removed from the film, although we rarely counsel its use. After fixing and well washing, apply a dilute solution of iodine and iodide of potassium, wash and intensify with iron and silver, or pyro and silver.

LINCOLN GREEN.—We cannot say with certainty how many times a good negative may be enlarged without offensive loss of definition. We have seen an enlargement of six diameters very good. 2. The No. 1 triple will probably answer as well as No. 2, and be more convenient to use. 3. The best advice we can give you is to read all that has appeared in our pages on the subject, and then practice until you get good results. If you prefer to have lessons, doubtless some of those who have given attention to the subject will teach you for a proper consideration.

J. FRANCIS.—There is no reason why on a fine day in the present month you should give anything like 85 seconds exposure for a portrait in the open air. Of course we cannot speak with certainty without knowing more of the conditions; but we obtained in London a good negative in about 15 seconds with a No. 1 B lens and half-inch stop, on a dry plate. The only course you can pursue, if you have no idea of the cause, is to proceed systematically; clean your lenses; try a fresh sample of collodion; try a new bath; try a fresh developer. Be assured, in any case, that the exposure you name is much too long from some cause.

J. MARTIN.—If you are satisfied that it is your sample of hyposulphite which causes the blistering, you had better abandon it, or have it exchanged, as it is probably adulterated. Bear in mind, however, that some samples of paper are very apt to blister when in the hypo. 2. Where extreme rapidity is important, you may work your No. 2 B without any stop, and get very good results; but where the light will permit, it will be desirable to use the No. 1 or 2 stop generally. Much, however, depends on the subject.

MELLIS.—We have never met with such a stain on a tannin and honey plate as that of which you send a sample, and we cannot speak with certainty of the cause. Primarily, it is probable that imperfect washing is the cause, some free nitrate having been left in the film when the tannin and honey was applied. Do you add a little acetic acid to the first washing water, as Mr. England recommended? Such a method is very favourable to cleanliness.

R. J. SPROAT.—We shall be glad to hear details of your process.

J. A. V.—The first are good, but not so good as the second. In our estimation, there is about the same difference in quality as in price.

HOBERTON.—We cannot speak with certainty, as we have not tried the lenses in question. It is probable that they are French, and will cover as well as such lenses generally do, being, probably, carefully selected by the dealer.

G. H.—In the London Photographic Society, if you join at the half-year, you only pay half a year's subscription. If you join at the forthcoming meeting, on the 3rd of November, you will pay half a year's subscription, besides the entrance fee, of course. Joining now will qualify you for exhibiting at the next Exhibition. 2. The time for sending in specimens will be duly announced. 3. The manager of our advertising department will communicate with you as to the price of an advertisement.

D. S. STURRO. has tried the addition of nitrate of soda to his printing bath, and signally failed. He wishes to know how the process can have succeeded in other hands, and failed so completely in his own? We are as much in the dark as he is; but it is clear the fault is in his manipulation, as we have seen many excellent results by the method obtained by others. Further, his bath contained 35 grains of nitrate of silver, he states, in addition to the nitrate of soda, and such a strength of silver ought to have guaranteed him against entire failure, even if the nitrate of soda exercise no influence whatever. The prints enclosed are mottled, marbled in a singular manner, as if portions of the paper had never come into contact with silver at all. Agitate your solution to mix it properly, and try again.

G. W. O. says that he has tried Hollis's Opal Mucilage and abandoned it, because it was manifestly acid, turning blue litmus paper of a bright scarlet colour. If this be the case, we should hesitate to use it. Our own sample was not acid, and we were assured it kept without any injury. We shall try it further.

AN OPERATOR.—The stain on the print you enclosed was due to some trace of hypo from dirty fingers, or some other cause, coming into contact with the print before fixing. 2. All the collodions you mention are good: we should prefer 3, 1, or 4.

C. W. L. F.—The use of a toning-bath of gold and lime, good negatives, and deep printing and toning, will give you perfect blacks. See some of the recent articles on lime toning.

D. C.—In order to copy an object the same size, you must draw out the body of your camera until the focussing-glass is the same distance from the lens as the lens is from the object. With a good lens, which will probably have about 6 inches equivalent focus, the distance will be about 12 inches. Place the picture to be copied in a good light, and the camera quite parallel at a distance of about 12 inches. Now draw out the body of your camera 12 inches, and cover over the space between the front and back with black velvet or cloth so as to make it light, and so improvise a long camera. By a little adjustment you will then get a sharp image the size of the original. Proceed then to take a negative in the usual way. You should procure a good manual giving information on these points. You will find Hughes's an excellent one.

HENRY PIPPETT.—Some samples of paper are more apt to lose tone in the hypo than others. When you meet with such a sample, tone much deeper than you would otherwise do.

B. B.—Your 2 B lens will cover about a half-plate, properly stopped down for landscapes. The front lens of the combination may be removed, screwed into the place of the back lens, which must be removed altogether; you will then have a landscape lens, producing pictures about 10 by 8, or thereabouts, the exact size we cannot state.

MEALIS.—We will write shortly.

J. H. UNDERWOOD.—We will return to the subject shortly.

W. ABERDEEN.—The required information in our next. Several Correspondents in our next.

Photographs Registered during the Past Week.

- MR. J. C. VYE PARMINTER**, Swansea Portrait Studio, Swansea, Photograph of Mons. Blondin.
MR. JOHN HAWKE, 53A, Union Street, Stonehouse, Devon, Two Photographs of Mr. R. N. Bailey, Temperance Lecturer.
MR. PETER LOW, 74, Jamaica Street, Glasgow, Photograph of the Rev. John Mc. Knight.
MR. JOHN STUART, 120, Buchanan Street, Glasgow, Two Photographs of the Rev. Mr. Mackay.
MR. THOMAS LOW, Meadowside, Dundee, Photograph of Sir David Baxter, Bart.
MR. H. F. NEWELL, York, Photograph of the Rev. Henry Gwyther. Photograph of the Rev. Henry Dowson.
DR. DIAMOND, Twickenham House, Twickenham, Photograph of Herne's Oak, as it stood in Windsor Park, prior to its being blown down.
MR. W. FARREN, 10, Rose Crescent, Cambridge, Photograph from a Sepia Drawing, entitled "Plucked."
W. AND D. DOWNEY, 9, Eldon Square, Newcastle-on-Tyne, Photograph of Dr. Headlam.
CAPT. ALEXANDER GEORGE TOD, 2, North Parade, Cheltenham, Two Photographs of the Rev. Edward Walker.

THE PHOTOGRAPHIC NEWS.

Vol. VII. No. 270.—November 6, 1863.

CONTENTS.

	PAGE		PAGE
Glasgow Art Union Photographs	529	Proceedings of Societies—Glasgow Photographic Association—	
Scientific Gossip	530	The London Photographic Society	535
On the Behaviour of Chloride, Bromide, and Iodide of Silver in the Light, &c. By Hermann Vogel	531	Correspondence—Foreign Science—Mounting Photographs—	
Improved Solar Camera. By John Stuart	533	Glass Houses and District Surveyors	538
The Ghost in the Negative	534	Talk in the Studio	539
Image on the Retina of a Dead Eye	535	To Correspondents	540
		Photographs Registered during the past Week	540

GLASGOW ART UNION PHOTOGRAPHS.

WE have considerable satisfaction in recording the fact, that the experiment tried last year by the Glasgow Art Union, of substituting the distribution of photographs amongst the subscribers instead of engravings, as heretofore, has been so successful and satisfactory as to induce the Committee of Management to make a similar distribution this year, and there is every reason to hope that the plan will not be discontinued, as we find the Lord Provost remarking at the annual meeting, that it was a great improvement on the old system, and gave great satisfaction to the subscribers. We are glad to record this, as we cannot forget that certain art authorities proclaimed last year, that such a step was merely the death-throe of an already moribund body, and that immediate dissolution must follow. We have reason to believe, however, that it was really the first step out of serious difficulties, and that it will lead to continued and increased prosperity.

The presentation photographs of last year, as many of our readers remember, consisted of copies of three original paintings amongst the chief prizes. This year we have a series of five paintings illustrating a special subject. It is entitled, "Bond and Free: Five sketches illustrative of Slavery, by J. Noel Paton, R. S. A." The photographs are by Mr. Thos. Annan, whose magnificent rendering of last year's pictures gave such satisfaction. It has been suggested that the selection of a party subject, the partial occasion at the present moment of one of the most terrible wars which ever disgraced the annals of the world, is open to some question. This is unquestionably to some extent true; but we apprehend that the treatment here is sufficiently broad to obtain almost universal sympathy; it simply offers an indignant protest against any child of man, however low in organization or degraded in habit, being held as the chattel of his fellow man; and there are few, however divided opinions may be as to the proper time and mode of ending this enormity, who do not agree in this protest. Be this as it may, however, the series of pictures is one which will command a wide circle of admirers.

The first picture of the series is entitled *Verbum Dei*. It is a figure of Christ, and grouped around his feet, some in passionate entreaty and some in despairing anguish, men, women, and children, bearing the badge of slavery. The simple majesty of the figure, one hand resting on the head of a kneeling figure from which grief seems to have exhausted all the tears, the other extended as in warning, is marvellously grand. The face is no longer expressive of gentleness and love only, but bespeaks the terrible-ness of the denunciation he is uttering, "Whoso shall offend one of these little ones which believe in me, it were better for him that a millstone were hanged about his neck, and that he were drowned in the depth of the sea." The excellent grouping, the fine chiaroscuro, and the severe excellence of the drawing, as well as the perfect rendering of the sentiment, constitute this a grand picture. The second of the series is

entitled *The Sale*: although a forcible picture, well drawn, and well grouped, it has a little of the clap-trap and exaggerated element in it. The sale is supposed to take place in the open street and within sight of the capitol at Washington; such a position, not true, and scarcely possible, is doubtless chosen with the painter's licence to give additional point to the horror. The prominent event, too, amid the many minor sad features of such a scene, is perhaps the most revolting ever associated therewith. A beautiful young girl, nearly white, is in the hands of the auctioneer; her dress, which suggests that she has been gently reared, is partially removed to show the faultless modelling of the bust and arms, whilst the luxuriant locks of waving hair are drawn through the auctioneer's fingers to display them to advantage. The poor girl hides her face in her hands, in speechless shame and agony. Some of the buyers look on with stolid indifference; it is so much business in course of transaction; others, with gloating salacious leer; there are partings, too, going forward, "such as press the life from out young hearts." The picture is altogether very fine and forcible, but almost unnecessarily painful. The next picture is not less painful: but here to depict the scene at all, it must be painful. It is entitled *The Capture*. Fugitive slaves, a father, mother, and child, have fled into the jungle, where they have been hunted down by bloodhounds, canine and human. The father has just been shot down, and the savages in pursuit are making their final dash in to secure the others; the mother stretches her arm with futile eagerness in front of her murdered husband, clasping close her babe with the other arm. A bloodhound has already, however, sprung at her, and men armed with rifles and revolvers are closing round. This picture is characterized by the same forcible and severe drawing as the others. The fourth picture in the series is one we like best, not merely for the sake of the subject, but for its admirable treatment, and exquisitely fine chiaroscuro. It is entitled, *The Rescue*. It represents the hold of a slave ship, with its living cargo packed and huddled together in their floating prison. The hatchway has just been removed, and eager faces full of honest manhood and good nature—British tars and British officers—are looking down, and strong arms are stretched forth to aid the poor fainting wretches to come forth into the blessed light of heaven that streams joyously down to carry hope into the dark prison. The varied expressions of hope, doubt, and of the "helpless, hopeless brokenness of heart" which is beyond hope, are wonderfully rendered, and as a study of light and shade, the picture is admirable. The last picture of the series is entitled *Freedom*. Well drawn, and in many respects a good picture, we like it least of all. It lacks variety of idea. The happiness of freedom seems rather dreary. The idea of freedom is chiefly rendered by groups of persons reading or being read to. The capacity to read and enjoy reading is surely one of the greatest gifts of God to man; but in a picture like this we should like some variety in the symbolical rendering; we should like to see the flourishing of the arts of utility and beauty; we should like to see the enjoyment of healthful

and innocent sports, and a variety of phases of enjoyment, besides reading good books and looking demure. With all the drawbacks to individual pictures, however, the series is a grand one; the art is very true, and has a noble aim.

Coming to Mr. Annan's share of the work, it is unexceptionable, and confirms his position as one of our very first masters of photographic reproduction. And here we have an interesting fact to record regarding the method adopted to secure the best results. The original sketches were drawn by Mr. Paton, the same size as they are now published, which is about nine inches by seven inches. Of these Mr. Annan made enlarged copies, about twice the size of the originals. Upon prints from these enlarged negatives Mr. Paton now made the corrections, which the enlargement of the drawings or the short-comings of photography showed to be necessary. It will readily be seen that the artist thus having an opportunity of touching upon his work would be able to supply many deficiencies, and add many skilful touches upon which the beauty of the finished result would largely depend. From these re-touched large prints, fresh negatives were made of the original size, and we have the result in prints admirably full of tone and gradation.

The great success of photography as a means of translating the works of the painter scarcely needs, in the present day, to be affirmed; it has come to be a largely-accepted fact. It is, however, satisfactory to be able to add the opinion of a gentleman of such high artistic eminence as Mr. Noel Paton in testimony of the fact. In a letter to the Secretary of the Art Union, he says, in regard to the last series:—"As photographs, they are certainly extremely successful. . . . Assuredly a photograph may be so managed as to convey with a fidelity, attained by but few engravings, the more subtle, valuable and least easily reproduced qualities for a work of Art; and I hope ere long to see the technical difficulties which at present, to a great extent, obstruct the application of photography to the reproduction of pictures entirely overcome. If the efforts of the Glasgow Art Union assist, as I have no doubt they will, in the accomplishment of a result so much to be desired, they will merit the thanks of all true lovers of Art." The method adopted this year by Mr. Paton's co-operation, which we have just described, will doubtless largely overcome any technical difficulties which may stand in the way of perfect success.

Of Mr. Annan's method of working there is nothing new to tell, as a source of success. He uses a bromo-iodized collodion, iron development, and triple achromatic lens. The secret of his success however lies in one sentence; he says, "My aim is never to be satisfied with anything, so long as I know it can be done better." We commend this mode of working to the beginners amongst our readers.

Scientific Gossip.

NEW PROCESS FOR SILVERING GLASS.—ALKALINE DEVELOPING AGENTS.—MODIFIED DAGUERRETYPE PROCESS.

PROBABLY, part of the reason why the old Daguerreotype process has fallen into disuse, is owing to the expense of the silvered plate, and the immense amount of trouble required in cleaning it for subsequent operations. Could these drawbacks have been easily overcome, there is little doubt that this process would have successfully held its ground, even against collodion; for, notwithstanding the perfection to which modern photographic processes have been brought, they can scarcely yet equal in delicacy, half-tone and softness a good Daguerreotype. Since Daguerreotypes have gone out of use, several methods have been devised for giving other substances besides copper a very perfect coating of silver. Thus we know many ways of precipitating a surface of absolutely pure silver on to glass in such a state that it will assume, with a little polishing, a surface more perfectly brilliant than could be obtained on a common Daguerreo-

type plate without a tedious amount of trouble; the silver, moreover, thus precipitated on the glass by chemical means, has the great advantage over the old plated copper in being absolutely pure—so pure, in fact, that silver so prepared has been used by M. Stas in his researches upon the atomic weight of this metal.

Among the many processes for silvering glass, that devised by Mr. Drayton is considered the best. The recent employment of silvered glass for the reflectors of telescopes having caused great attention to be directed to this subject, many endeavours have been made to simplify the somewhat complicated operations. A process has just been published by Mr. Martin, which, from the firm adherence of the layer of deposited silver, and the simplicity of the different steps of the operation, seems to fulfil all the conditions necessary for rendering the method of general use. The solutions are four in number, they require some care in their first preparation, but once made they are always ready, and can be used with great rapidity and certainty for depositing a lustrous, mirror-like surface of silver on a piece of glass of any desired shape or curvature.

Solution 1 is prepared by dissolving one part, by weight, of nitrate of silver in ten parts of distilled water.

Solution 2 consists of an aqueous solution of pure ammonia, having a density of 13° Cartier.

Solution 3 consists of four parts of pure caustic soda in 100 of distilled water.

Solution 4 is made by dissolving 12½ parts of the best white loaf sugar in 100 parts of distilled water. To this add 1 part, by measure, of nitric acid, boil for twenty minutes, in order to alter the molecular arrangement of the particles of the sugar, and then add water to increase the volume to 500 parts by measure, and finally add 50 parts of alcohol.

These solutions will remain unchanged for a long time. When required for use, prepare an argentiferous liquid by pouring into a flask 12 parts, by measure, of the silver solution, No. 1; 8 parts, by measure, of the ammoniacal solution, No. 2; then 20 parts of the soda solution, No. 3; and, lastly, add 60 parts of distilled water, in order to make up the volume to 100.

If the proportions have been properly observed, the liquid so prepared will be perfectly clear, but will be rendered turbid by the smallest addition of nitrate of silver solution. It must be allowed to remain without disturbance for twenty-four hours to permit the floating particles to settle. The clear liquid decanted from the sediment will then be ready for use.

The surface of glass which has to be silvered must be well cleaned with a tuft of cotton and a few drops of nitric acid, and then washed with distilled water. Drain it, and support it on the surface of the silvering bath, which is composed of the above-described argentiferous liquid, with the addition of 1-10th or 1-12th by volume of the sugar solution, No. 4. The surface to be silvered should, by preference, be at the upper part of the liquid, so that the silver may be deposited on it from below upwards. There are two advantages in this—1, the deposit is finer and more even; and, 2, there is no danger of floating particles of dust settling on the surface. It is, however, scarcely necessary to say that silver will be deposited upon every part of the glass which is under the surface of the liquid, as well as upon the sides and bottom of the vessel, so that, as a matter of economy, as little as possible of the back of the glass should be exposed to the action of the liquid. The action seems to be somewhat of a photogenic character, being more rapid in the light than in darkness. Under the influence of diffused light the liquid becomes yellow, then brown, and in a few minutes the whole of the exposed surface of the glass will be covered with a fine deposit of silver. In about a quarter of an hour the thickness of the metallic coating will be sufficient to bear the subsequent operations without injury; it must then be washed with plenty of water, and rested by one corner on several thicknesses of blotting paper to dry spontaneously. The surface will now be covered

with a thin whitish veil, which may be readily removed by gentle friction with chamois leather; it may afterwards be polished with jewellers' rouge, when a perfectly brilliant surface will be produced.

We are aware that some experiments have been tried on the application of similarly silvered glass plates to photographic purposes, but they have certainly not been followed up with as much perseverance as so promising a line of research deserves. Not only may the ordinary operations of the Daguerreotype process be performed upon such a surface with far more chance of success than when a clumsily rolled silver-copper plate was the basis of the photographer's manipulations, but we have little doubt that a somewhat similar process to the one in present use, or a modification of that and the Daguerreotype, could be worked out without an incommensurate expenditure of time and trouble. The surface of silver is readily converted into iodide by exposure to the vapours of iodine, and the compound thus produced could be treated as a prepared Daguerreotype; the silver could also be converted into iodide of silver, by being washed over with an alcoholic solution of iodine, or an aqueous solution of that element in iodide of potassium. The iodide of silver prepared thus in the moist way would, no doubt, have similar properties to that prepared by double decomposition in the collodion process, and, like it, could be rendered sensitive by a bath of nitrate of silver, and, after exposure, developed by any of the ordinary developing agents. It would also be interesting to try whether a combination of the two processes would not give good, and, perhaps, novel results; thus the silver could, in the first place, be iodized in the dry way, the subsequent operations being performed as in the wet process.

It would also be interesting to see whether the silvering solution used to deposit the precious metal on the glass surface would not constitute an excellent developing solution, both in this suggested process and in the ordinary collodion process. The action is certainly more energetic under the influence of light; and, as a general rule, it may be stated that the action of visible radiant light in inducing chemical change is similar in its effects to the continuing action in the dark which radiant light induces in compounds of silver with iodine, and other members of that family. The silver would, we have little doubt, be deposited by the liquid only upon those parts of the sensitive surface where the equilibrium had been previously disturbed. Most of the developing agents in common use would act in darkness after the lapse of some little time, without any action being previously set up by light, and in this respect the resemblance between the solutions is complete. The deposited silver would most probably retain the same character as when originally precipitated on the glass, and the developed image, viewed as a positive, would have the peculiar brilliant appearance which was formerly so much admired. We should think that such a solution, alkaline in its character, would be especially useful in some of the dry processes, where the development, proceeding more leisurely, the molecules of silver would have time to arrange themselves on the plate in the manner most agreeable to themselves, and therefore more likely to stand any subsequent friction which would be necessary to obtain a good polish.

ON THE BEHAVIOUR OF CHLORIDE, BROMIDE, AND IODIDE OF SILVER IN THE LIGHT, AND ON THE THEORY OF PHOTOGRAPHY.*

BY HERMANN VOGEL.†

α. Experiments with pure Chloride, Bromide, and Iodide of Silver.

CHLORIDE of silver was prepared under a dull gaslight by precipitating nitrate of silver with an excess of pure chloride of sodium. It formed the well-known caseous mass, and was easily

filtered and washed. The washing was continued until the water gave no reaction of chlorine. Bromide and iodide of silver were prepared in like manner by precipitating nitrate of silver with an excess of bromide and iodide of potassium. Both were thrown down at first in a caseous form, but afterwards, as the precipitant was added in excess, formed a fine powder, which was very slowly deposited, ran partly through the filter, and stopped its pores.

The chloride thus obtained appeared white, the bromide pale yellow, and the iodide straw yellow. They were all dried, after careful washing, and kept in the dark.

To test their behaviour towards light, they were divided into small portions in test-tubes by lamp-light, and broken up with a glass rod; the test-tubes were then closed with a cork, or sealed up, and exposed to the light. In this way a number of tubes were filled with the three salts, and simultaneously brought into the light. In a short time a change of colour was observed in the chloride and bromide. The chloride became violet, the bromide grey. These colours increased in intensity with time, but in a few days attained a maximum. The chloride then appeared brownish violet; the bromide *impure pale greyish violet*. This colour was only superficial; the centre of the samples remained white.

The iodide of silver, prepared as above, did, on the contrary, not undergo the least change of colour, even by exposure for months to an *intense* light.

In most chemical text-books it is stated that chloride and bromide of silver "*bleichen*" in the light. This is incorrect. Even by exposure to the light *for years* pure chloride and bromide of silver undergo no blackening, they become coloured only as above described.

Seebeck, moreover, states (Poggendorff's *Annalen*, ix. p. 172) that the blackening of chloride of silver takes place only in the presence of moisture. This also is incorrect. Chloride of silver when perfectly dry, or even fused, acquires a violet colour when exposed in a sealed tube.* This change of colour is accompanied by a *chemical* change, which is manifested by chlorine and bromine being set free. I ascertained both—

α, by the odour, which was also observed in the case of the chloride by Scheele, Wetzlar, Wittstein, Hunt, and others; and

β, by the reaction with iodized starch-paper.

I exposed simultaneously to the light of the sun a tube with chloride and another with bromide of silver, having strips of iodized starch-paper fixed in their corks. The chloride of silver soon became pale violet, the bromide grey. Within a few minutes the end of the paper nearest to the bromide of silver acquired a faint blue colour; in the case of the chloride, distinct coloration did not make its appearance until the lapse of a quarter of an hour. In half an hour the strip of paper with the bromide was intensely blue; subsequently its lower extremity became yellow, certainly in consequence of the formation of bromides of iodine and starch. The strip of paper with chloride of silver was coloured more slowly. The experiment was repeated with the diffused light of the blue sky, and gave the same result. The paper with the bromide of silver became more rapidly and deeply blue than that with the chloride. The same experiment was made with fused chloride and bromide of silver. These were exposed in sealed tubes for several days, and, on opening them, a strip of the starch-paper was introduced. This was but slightly coloured by the chloride of silver but much more distinctly by the bromide. From these experiments it is evident that chloride and bromide of silver are decomposed with evolution of chlorine and bromine by exposure to the light, and that this takes place *more* rapidly with the bromide than with the chloride.

We have now to consider the question as to what compound remains after the exposure of chloride and bromide of silver. As we have only pure chloride and bromide of silver to deal with, and the experiments just described prove the evolution of chlorine and bromine, the following cases only are possible:—

1. Ag Cl and Ag Br are decomposed into their constituents—silver and free chlorine or bromine;
2. There is a production of a subchloride and subbromide and of free chlorine and bromine.

* We have a sample of dry chloride of silver which has been exposed to light in a stoppered bottle for nearly four years without any change. The sample was prepared and given to us by Dr. Alfred Taylor, of Guy's, and was prepared by the action of chlorine upon silver foil. There is not, we believe any free chlorine.—ED. P. N.

* Continued from p. 5-3.

† Poggendorff's "*Annalen*."

No third case is conceivable.

If the first decomposition be the true one, free silver must be present in the masses of chloride and bromide of silver affected by light. To ascertain this, I boiled chloride and bromide of silver which had been exposed for months to the light with pure nitric acid of spec. grav. 1.2. I then allowed the chloride and bromide to settle completely, drew off the clear fluids with a small pipette and tested them for free silver, by carefully floating upon them very dilute muriatic acid. The smallest trace of free silver is thus betrayed by a white cloud. *No such trace could be discovered in my frequently repeated experiments either with chloride or bromide of silver.* This indifference towards nitric acid was also manifested by the very small change of colour which the chloride and bromide underwent when boiled with nitric acid. Even when exposed chloride and bromide of silver were left standing for months with nitric acid not a trace of silver was dissolved. From this we are justified in assuming that, during the exposure of chloride and bromide of silver to the light, a subchloride or subbromide is formed—an opinion which has already been expressed with regard to the chloride by A. Vogel, Wetzlar, Wittstein, and others.

Guthrie's objection that the silver occurs in the passive state, that is to say, insoluble in nitric acid, is scarcely worth refutation. A passive state is the consequence of a coat of oxide or chloride which is formed upon the metal. But how can we assume the formation of a chloride, if we at the same time assert that this is decomposed by the light?

Hurst's assertion that oxide of silver is formed, is likewise invalidated by my experiments; for in this case it must be dissolved by the nitric acid, and thus manifest a silver reaction. Spiller's assertions are too hypothetical in their nature; he expresses opinions only half supported by facts.

Dawson's experiments (*vide supra*), are of more importance. He found that chloride of silver, after exposure to the light with solution of free silver or of chloride of sodium, contained free silver. This fact, however, is by no means surprising; for solution of nitrate of silver is slowly decomposed by the light of the sun, and deposits black spangles of metallic silver, as I have found by experiment; hence chloride of silver exposed with a solution of free silver, must contain free silver. But even the presence of free silver in chloride exposed with an excess of chloride of sodium, need not astonish us; for the latter is able to decompose Ag^2Cl , with separation of Ag, as was discovered by Wetzlar (*loc. cit.*). Maloué's views prove nothing against my theory; for the assertion that the brown fluids obtained by him by mixing a solution of phosphoric ether with one of silver contain metallic silver is not proved, and I might call attention to the fact that the solution of Wöhler's protocitrate of silver is likewise of a brown colour.

It is certainly impossible to determine the quantitative composition of the subchloride formed by the action of light, as only the outermost stratum of the salts in question is affected by exposure, and this cannot be separated from the subjacent, unaltered chloride and bromide.

On the other hand the qualitative reactions are of importance. If ammonia be poured over chloride of silver deeply coloured by exposure, the greater part of the latter is dissolved, and grey granules remain. By pressure with a glass rod these become silver-white and of metallic lustre; and as they dissolve readily when heated in ammonia, they are metallic silver.

This reaction, which induced Scheele to assume the presence of metallic silver in chloride of silver after exposure to light, is presented also by the pure subchloride, as prepared by Wetzlar and Wöhler. The former obtained it of a black colour by the action of perchloride of iron upon silver leaf (*loc. cit.*); Wöhler procured it of a brown colour by precipitating a solution of protocitrate of silver with hydrochloric acid (Poggendorff's Annalen, xvi. p. 629.) This body also yields no silver to nitric acid (Wetzlar), and is decomposed by ammonia, chloride of silver being dissolved and silver remaining (Wetzlar and Wöhler). Its indifference towards nitric acid proves that this body cannot be regarded as a mixture of chloride and metal.

All doubt as to Ag^2Cl being contained in chloride of silver coloured by exposure to the light must, however, disappear, if we can obtain by other means, from compounds undoubtedly containing protoxide of silver, mixtures of subchloride and chloride silver similar to those produced by light. In this I succeeded by the agency of Rose's compound of protoperoxide of iron with protoxide of silver, obtained by pouring sulphate of iron into an ammoniacal solution of silver (Poggendorff's Annalen, ci. p. 321.) When hydrochloric acid is poured over this compound,

the oxides of iron are dissolved, and there remains a violet powder, which, both in its colour and its behaviour towards nitric acid and ammonia, precisely resembles chloride of silver coloured by exposure to light.*

I succeeded yet another way in preparing a similar violet colour, chloride of silver. I found (Poggendorff's Annalen, cxvii. p. 316,) that my crystallized peroxide of silver, which, when fresh, appears pale violet colour, when exposed to the light, very soon becomes black, with evolution of oxygen, at the same time losing its lustre. The black body dissolves in dilute nitric acid, and in ammonia, leaving a residue of black, granularly pulverulent, metallic silver, which, when pressed with a glass rod, becomes silvery white and shining. That this silver does not pre-exist in the black body, appears from the fact that it cannot be detected by pressure with a glass rod. The oxide of silver altered by exposure to light, consequently consists of a mixture of Ag^2O and AgO , and the former, when treated with acids or ammonia, furnishes granularly pulverulent silver, exactly like Wöhler's protoxide of silver. This oxide of silver, blackened by the light, gives with hydrochloric acid a body precisely similar to chloride of silver coloured by light, both as regards colour and behaviour to acids and ammonia.

I likewise found that carbonate of silver exposed to the light furnishes a body which produces with hydrochloric acid a chloride of silver containing subchloride; and, judging from this, it seems extremely probable that all silver-salts which are reducible by light are reduced first of all to the state of protoxide, or of a haloid salt analogous thereto, and that, in all cases in which metallic silver has been at the same time detected, this is a secondary product resulting from the decomposition of the protoxide of silver formed by the action of light.

Just as I obtained a chloride of silver containing subchloride, I also produced a bromide containing subbromide, namely, by treating Rose's compound with dilute hydrobromic acid, the latter prepared by the distillation of bromide of potassium with sulphuric acid. There was produced a pale greyish-violet body, perfectly similar in appearance to the bromide of silver after exposure to light. By boiling with nitric acid it became grey, and this also was the case with exposed bromide of silver. It also yielded a trace of silver; but this certainly originated from the material used, as, after washing and further boiling, no more silver was dissolved. The mass which had been boiled with nitric acid, when treated with ammonia, acquired a darker grey colour, and a grey powder settled to the bottom. This dissolved in nitric acid, and then gave a silver reaction. The same reaction was exhibited by bromide of silver, after exposure to light. I poured ammonia over this, when a small portion was dissolved; by decantation and repeated treatment with ammonia, all the bromide of silver was at last dissolved, and there remained a few small, delicate granules, which dissolved in nitric acid, and then gave a reaction of silver.

As the removal of the whole of the bromide of silver is troublesome, and during it the small quantity of silver separated may easily be washed away, I poured ammonia over these other portions of bromide of silver which had been exposed to the light, and then washed them simply with water. The Ag^2Br formed upon the surface must evidently have been decomposed by this means, and left behind with the undissolved bromide of silver. This yielded distinctly demonstrable quantities of silver to nitric acid, whilst no trace of silver was extracted by nitric acid from the bromide of silver which was not treated with ammonia.

It is, therefore, evident that bromide of silver behaves exactly like the chloride when exposed to the light,—that by this means a body is produced which exhibits the same behaviour towards reagents as the exposed chloride, justifying the conclusion that it contains sub-bromide of silver (Ag^2Br). The sub-bromide, however, appears to offer greater resistance than the subchloride to decomposition with ammonia, which is certainly due to more difficult solubility of bromide of silver in ammonia. The silver reactions presented by chloride of silver exposed to the light and treated with ammonia, were much more intense, under otherwise similar circumstances, than those of the bromide under the same treatment, and I found this to be the case also with the bodies produced from Rose's compound with hydrochloric and hydrobromic acids.

(To be continued.)

* I must remark that I do not quite admit the composition of the black body given by Rose. I shall take another opportunity of reverting to this point.

IMPROVED SOLAR CAMERA.

BY JOHN STUART.*

I COULD have wished that some subject more interesting should have engaged your attention on this the opening night of the season. The difficulty attending a description of the solar camera, which I have just constructed, is great indeed; to understand it well, you would require to see it; but my task to-night is, by the aid of a model, photograph, and description, to bring my latest improvement on the solar camera before you. If I could have shown you a larger collection of photographs taken by it, it would no doubt have been much more interesting to you; for me to have more was quite impossible, as, since it was finished, we have had no sunshine worth speaking of. If you remember the faults which I pointed out in the old style of solar camera (with the mirror), you will then be able to understand what I have tried to avoid in the new one. Looking at the model or the photographs, you may be apt to think it rather a formidable piece of apparatus for the operating rooms of a photographer, and, doubtless, it would be to have it in his operating room; but it is not intended to be placed there, but is operating room and solar camera combined, and can be placed in the top of the house or (as in my case) in the garden, placed so that no high houses will intercept the sun's rays. I will now proceed to describe in detail (as well as possible) its form and construction. Some of you may have some difficulty to understand me from the terms requiring to be used, but after I have finished the description, I will be happy to explain to any of you, from the model or photographs, any part of it you may not have understood.

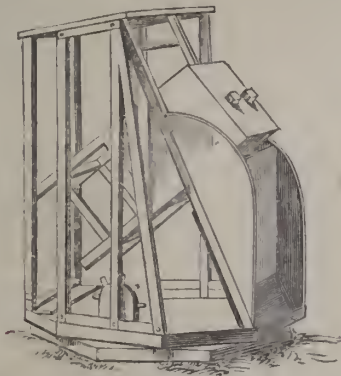

Beginning at the foundation, the first part is a frame of an octagon shape, the square of which is about 11 feet, formed of planking 9 in. broad by 3 in. thick. Bound together at the angles, by bolts running at right-angles, are two planks of same size, which intersect at the centre of the octagon, and serve to fix a centre-pin for the house to turn upon. Upon this octagon-shaped frame is fixed a circular iron rail; to the inside of the rail, and on the plank, is fixed a tooth and pinion rack, all the way round, or nearly so. Above the frame already described is another of the same shape and size, and similarly constructed, but not of such heavy timber. Upon the under side of the frame are fixed grooved wheels, which work upon the circular rail. This frame is covered with flooring, which forms the floor of the house. Sitting on the top of the flooring is a combination of tooth and pinion wheels, which works on the rackwork under, and serves to turn round the upper frame. Looking at this part, which I have described, you would almost be inclined to take it for a railway turning table. You will now please follow me, while I, step by step, build up the house upon the table, which I have just described. Referring to the model, you will see that the back part of the house stands perpendicular, the front sloping in towards

the top, the object of which you will presently understand. At the points of the octagon-shaped frame are placed posts, which run up to the height of about 14 feet, and are 5 in. by 4 in., and bound together at the top by a frame which slopes down towards the back, so as to run the rain off by the back of the house. Owing to the slope in front, the top of the house is only about 11 feet by 5; the framework is then closed in by lining nailed upon carps (in this lining there is a space left for a door, so as to give easy ingress to the house), and when fitted in between the standards, it is only screwed up, so that it may be easily removed in case such should be required. The framework and lining can all be undone in about an hour's time, and packed up in bundles. In the front space, the lining only comes up about five feet, two shutters close up the rest of the space, the one a rolling, and the other a sliding shutter. With these the space is closed up, when the camera is not in use, which keeps the place wind and water tight; the next part which I have to describe is the camera proper. It is a square frame, 15 feet long, 5 feet broad, by 3 feet 6 in. wide, with rails running through it at various intervals, so as to make it as firm as possible, and as light as is consistent with rigidity. The part of the frame which is exposed, when working (see photograph), is covered with cloth, so that the joints, though coming and going with the weather, will not admit the light. In the inside of this frame is a moveable partition of black cloth, running from top to bottom; also two frames, horizontal to this partition, which move upon sliders, to serve as focussing screens to receive the image. On the top of this camera proper are placed too small boxes, which hold the condensers, the negatives, and enlarging lenses. In the inside there are arrangements for focussing, also for a horizontal and vertical motion of negatives. All the movements have to be so arranged that they can be pinched up with screws, so that in the process of printing no further movement can take place, as the slightest motion would be fatal to a good result. The square frame, which I have just described, is then hung on its centre, or as near as possible, so as to give balance, and when so hung, moves to ascension and the declension of the sun. That this motion may be performed with ease, it is swung down on the top of sliding shutter. That shutter is raised and lowered by an endless chain, running over pulleys, and wrought by suitable machinery inside solar camera house. The camera, when attached to the shutter, is

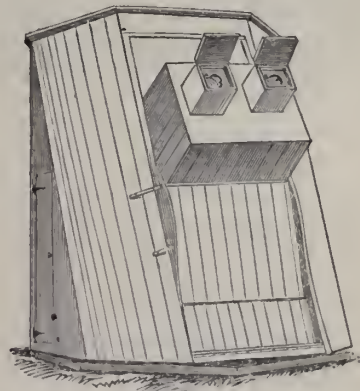

taken up and down with it; when not in use it is detached from the camera, thrown back, and stands perpendicularly. By the means already described we have got the two motions. The great objection urged against solar cameras is the difficulty of keeping the sun shiing parallel through the condenser and enlarging lens all the time of printing. In this I find no difficulty. The way I keep the sun in the same place all the time is by having a tube fixed by the side of the camera, and running parallel with it. Through this tube the sun must shine, and it will only do so when the

* Read at the Glasgow Photographic Association, on the 23rd. ult.

camera is kept directly pointing to it; and if such is the case, the rays must strike the centre of the condenser and enlarging lens. You may ask, Well, what are the advantages to be gained for all this extra expense? In the first place, you can print the pictures in about one-half the time taken by a mirror camera. Secondly, two pictures can be done at once, one motion serving both. Thirdly, any lad with ordinary judgment can work the camera. Fourthly, the pictures obtained are much sharper; and although there are no perfect specimens to-night, I am fully persuaded, from what I have seen of the working of both machines, that the superiority of this over the reflecting camera is beyond dispute.

THE GHOST IN THE NEGATIVE.*

OBSERVE the illuminated circle on the ground glass of a camera which has been produced by certain lenses, when those lenses especially are directed so as to take in the direct rays of the sun or from a very brightly illumined cloud; you will ascertain a central part or central parts different from the rest, more hazy and indistinct, although in general exhibiting more illumination. Such lenses will produce on the negative under such circumstances the "Ghost."

It becomes our task to endeavour at least to demonstrate, what are some of the causes that produce this spectral apparition, this spirit of a picture.

In the first place, let us make an experiment.

Take a lens, as, for instance, AB in the figure, of about four inches in diameter, and whose radii of curvature are short, that is, whose magnifying power is great; and hold up the lens so as to catch the rays of the sun, and find the burning point or focus of the lens. Let OQ represent a beam of such rays, which, after refraction, will cross each other in the point C at the other side of the lens, and will produce combustion there on any combustible body. This is the burning point or the principal focus of the lens. In addition to this focus, however, such a lens has frequently two other—speaking in general terms—or secondary foci, whose position we will point out.

Whilst an assistant is holding the lens so as to produce combustion in C, or, better still, let the lens be fixed in a rigid stand capable of the proper adjustment as to direction; then, bringing your finger into the axis of the lens, and between the sun and the lens, as in the point E, you will desery another illumined point, where combustion can in like manner and cosentaneously be produced, though more feebly. It is, however, a fact: a match can be set on fire either at E or at C.

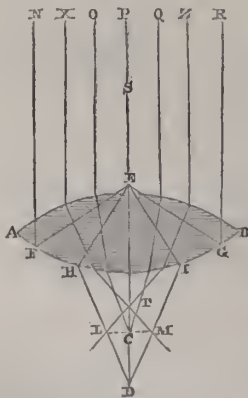

We expect, therefore, to find a picture of the sun both at E and C. The picture at E is formed by rays reflected from the concave surface AFHIGB, but especially by those peripheral rays, such as NF and RG, and others exterior to them,

* From *Humphrey's Journal*.

when they form an angle of incidence equal to or greater than $40^{\circ} 49'$, which is the limit for transmission for crown glass.

Furthermore, if the lens has not been corrected for spherical aberration, we shall have an innumerable quantity of foci for the peripheral rays along the axis from C towards T and onwards towards the vertex, until transmission is no longer possible.

Now the picture at E may be regarded as an independent sun which will produce, according as its position is nearer to the lens than the principal focus or farther off, either a virtual image on the axis towards P or beyond, or a real image as at D.

Thus, then, the central rays or the beam OQ from the sun form an image of the sun at C; the rays XH and ZI, being more external, will form a distinct focus at T, where they cross and, arriving at the ground-glass, cover the space LCM, where the image is much enlarged and indistinct.

The rays NF and RG, still more external, and making angles NFE and RGE greater than $81^{\circ} 38'$, will produce a reflected image of the sun at E, and the rays EH and EI of the pencil FEG will form another image of the sun distinctly at D, but very indistinctly and enlarged on the ground-glass on the space LCM.

It is evident then, if matters be as we say, that we shall be troubled with ghost-like apparitions on our negatives in the central parts under the following circumstances:

1. If the lens is not thoroughly corrected for spherical aberration.

2. If the radius of curvature of that surface of the lens next to the ground-glass be so small as to cause any of the external parallel or oblique rays to be reflected back, inasmuch as the incidental angle exceeds the angle of transmission.

3. If so much of the lens be left exposed as to allow the above mentioned external parallel or oblique rays to act.

4. If the lens, under the above-quoted conditions, be exposed to the direct rays of the sun.

Supposing the lens be well corrected for spherical aberration, it may still give rise to the apparition in question.

It will be seen from the above discussion that the *Ghost* on the negative is not a fortuitous phenomenon, but one which the optician has quite under his control without the intervention of holy water or any other spells of *exorcism*.

In the first place, the lens or the combination of lenses must be well corrected so as to bring all the foci of central and peripheral rays, whether parallel or oblique, upon the same flat surface or plain perpendicular to the axis of the lens. To do this, the lens will have to be cut down considerably on the edges, by which the central parts alone must be made available; or parallel rays alone be admitted, which is effected in a great measure by elongating the *obturator* in front of that surface which is exposed to the object to be copied.

Secondly, the posterior surface of the last lens, if convex, as well as of any other intermediate and independent lens, if convex, must have a convexity of such a nature as to preclude the possibility of reflections, whether by parallel or oblique rays, at angles at which transmission is impossible.

Globular lenses, corrected for spherical aberration, like Coddington's, or for spherical and chromatic aberration like Harrison's, if a large part of the spherical surface of said lens be left exposed, must of necessity be *haunted*; and the *falling flap* on the camera will not keep out the sprite; but it certainly will shake the camera in the act of opening and closing, and on that account it ought straightway to be exploded, and better means ought to be applied (they are already devised) for covering and uncovering the aperture.

This trouble produced by reflections and otherwise, denominated the *Ghost*, is no new epidemic in optical combinations; the astronomer, or at least the astronomical optician, has frequently seen the pictures of two suns in his telescope, and has had to grind his objectives so as to get rid of one of them (the spirit of the other); but that a lens has *two burning points*, one on either side, the one produced

by reflection and the other by the transmission of light, appears to be a *novelty in optics*, to which our attention was first called by Mr. Henry Fitz, of New York, an astronomical optician of whom we Americans have a right to feel proud.

No sooner was this attention once called to the matter, than we verified the fact by burning a match cosentaneously on either side of a lens; and no sooner was the fact established than the consequences stood out in bold relief; the remedies of the evils produced became apparent, and the *Ghost* can easily be *exorcised*.

But woe unto the angle of aperture when the evil spirit runs away with swine!

[The existence and influence of these secondary foci arising by reflection from the cave surfaces of the lenses is most interesting and important. Although not entirely new to experienced opticians, it is in this article, by Professor Towler, for the first time, we believe, noticed. It is probable that a recognition of the fact, and a more careful examination of its operation, may lead to results tending to the removal of some defects at present existing in photographic lenses.—Ed. P. N.]

IMAGE ON THE RETINA OF A DEAD EYE.

THE *Evansville Journal* has the following:—

"We believe it is one of Mrs. Southworth's stories, in the *New York Ledger*, that represents a murderer as being convicted by a photograph of his victim's eyes, upon the retina of which was pictured the features of the assassin. Similar experiments, we are informed, have been made in France with great success, and mysterious murders unravelled through the instrumentality of Dagnier's wonderful art. Notwithstanding we had heard of these strange things, we were still under the impression that "dead men tell no tales," until a recent experiment has shaken our faith, and almost convinced us that though dead, men yet speak.

"On Sunday forenoon, Mr. Adams, a photographer of this city, at the solicitation of some gentlemen who had read of similar experiments in France, took his instrument and visited the scene of the late murder in German Township. This was some thirty hours after the murdered man had breathed his last. There was a great deal of dust flying and a great crowd collected, which materially interfered with the success of the experiment; but notwithstanding these unfavourable circumstances, Mr. Adams succeeded in taking a tolerably fair "negative." Upon this he has been experimenting, and yesterday we were called on to witness the results of his experiments.

"He had taken an ambrotype picture of the eye of the deceased, and then rubbed out everything but a single object apparently in the centre of the eye; this was placed under an ordinary magnifying glass. At the first glance the object appeared blurred and indistinct, but on getting the proper focus the outlines of a human face were at once distinguishable. The image was apparently the face of a man with unusually prominent cheek bones, long nose, and rather broad forehead. A black moustache was plainly seen, and also the direction of the eyes, which seemed to be looking at some object sideways. One of the eyes was as plainly seen as the eyes in a common ambrotype or ferrotype. Some who examined the image, thought the man of which it seemed to be a resemblance, had a Roman nose, and also had on a cap.

"Mr. Adams is continuing his experiments, but whether he will succeed in making any clearer developments, remains to be seen. His labours thus far are abundantly rewarded by the success which has attended his efforts, as it seems to us he has demonstrated that an object was pictured upon the eye of Mr. Herke at the time of his death, and that the object was a human face."

The Editor of the *American Journal* adds:—

"Some things are important, if true, others are interesting, in the language of the African, "whedder or no." The

above comes under the latter category. Mr. Adams is one of our subscribers, and, if he succeeds in getting any "clearer developments," we may expect to hear from him."

Proceedings of Societies.

GLASGOW PHOTOGRAPHIC ASSOCIATION.

THE annual meeting of this Association was held in the Rooms, Bath Street, on Wednesday, 20th ult.—Andrew Mactear, vice-president, in the chair.

Mr. EDMUND BRACE, the hon. secretary, read the annual report, of which the following is the more material portion:—

The Council of the Glasgow Photographic Association, in meeting the members at the close of the present year, feel much pleasure in being able to congratulate them on the success which has attended their first session, and which is mainly attributable to the good feeling and unanimity that has so happily subsisted amongst all its members. The Council find that during the past year forty-one new members have been admitted by ballot, and with the most lively satisfaction do they record the fact that there has not been even a solitary withdrawal. Two honorary members have also been elected. First, Dr. Taylor, of whose connection the society may well be proud; and second, Mr. Crombie, of New Zealand, whose pictures met with distinction at the Great Exhibition of 1862, and who is the author of one of the papers read before the society during last session. The past session was opened on the 4th September, 1862, with a very interesting address from the President, after which Mr. Vice-President Mactear gave a humorous account of a summer photographic excursion, and at the subsequent monthly meetings papers were read by the following gentlemen:—

Mr. John Stuart—"On Enlarged Pictures by Woodward's Solar Camera, and How to Tako Them."

Mr. J. N. Crombie, of Auckland—"On the Rise and Progress of Photography in New Zealand."

Dr. Taylor—"On Dioramic Effects produced on Photographic Pictures."

Mr. Vice-President Mactear—"On Photolithography."

Mr. J. Ewing—"On Manipulation, Developing and Intensifying the Negative."

The President—"On the Formation of Nitrate of Silver from an Impure Source, with Separation of Impurity; Do. from Pure Silver, with Proof in Favour of Atomic Theory; also, some General Remarks on the Sensitizing Bath."

Mr. A. Maenab—"On Copying and Enlarging Pictures." And

Mr. J. Stuart—"On Mounting Photographic Pictures."

It would be invidious to refer to any of these papers specially—many of them were admirably illustrated either by direct experiment or otherwise, all of them listened to with marked attention and interest, and most of them followed by animated discussions, in which the various suggestions brought forward were thoroughly elucidated. The Council would strongly urge that the greatest encouragement should be given to such discussions, feeling well assured that they cannot but be most conducive to the progress of the art; and being also convinced that every question, however trivial, put with a sincere desire for the acquirement of knowledge, will be answered not only with cheerfulness, but with the greatest pleasure, as the universal spirit of progression should, and they firmly believe will be uppermost at all the meetings of this Association. And here the Council may record their thanks to the professional members of our society, who have not only displayed an absence of jealousy (too often remarkable in professional men), but have always manifested the greatest readiness to communicate the progress of their daily experience, ever being animated by those broad and enlightened principles by which alone ultimate perfection can be obtained. In the session now commenced the Council are happy to announce that they have succeeded in securing the services of many whose attainments are well known and deservedly respected, and it is with great pleasure that they are enabled to lay before you the subjects appointed for discussion during the whole of the forthcoming session, and which they flatter themselves you will admit to be most interesting in the present and valuable for the future of that art, for the diffusion of which our society has been established. On the 19th February last, in compliance with the decision of

the Council, confirmed by your own resolution, a soireé, exhibition, and conversazione was held in the Merchant's Hall, when about 400 persons were present. Dr. Allen Thomson, F.R.S., kindly presided and delivered a very interesting address. Other addresses were delivered, and a collection of photographic pictures and other objects of interest exhibited to the meeting. The meeting was a decided success, although there were many defects in the arrangements (almost necessarily incidental to the first attempt at a meeting on so large a scale), which the Council have no doubt will be obviated at a future meeting. The Council might suggest as worthy of consideration, whether future meetings might not wisely partake more of an exhibition (to remain open for some time), concluding with a conversazione in preference to anything in the shape of a soireé. In a pecuniary point of view, this meeting has been a trifling loss to the Society, the receipts having been £23 15s. 6d. and the expenses £29 16s. 4d., showing a deficit of £6 0s. 10d., which was supplied from the ordinary funds. Finding the want of increased accommodation for the ordinary meetings of the Association, your Council, in November last, appointed a committee to look after more suitable rooms, and the result was that the meeting for the month of December was held at the Scottish Exhibition Rooms, Bath Street, and that place of meeting was continued during the remainder of the session, they trust, to the additional comfort of the members; at the same time, even that place leaves still much to be wished for in the shape of accommodation, and it would be very desirable that the Association should have rooms altogether its own, in which a library could be formed, pictures and apparatus permanently exhibited, and much other useful accommodation obtained, could funds be raised sufficient for that purpose. They would, therefore, direct the earnest attention of the Association, to this most important subject, and trust some plan may be devised, by which so very desirable a point may be attained. Your Council may here mention that towards the formation of the library two volumes on photographic chemistry have already been presented by Mr. A. Robertson, your worthy treasurer, and doubtless others will soon follow so excellent an example. Mr. Robertson has also presented an album for card pictures. Your Council feel great pleasure in reporting that the general funds of the Association are at present in a healthy condition, and from the treasurer's accounts it will be found that a balance of £2 18s. 11d. remained in hand at the close of the year. In resigning their trust into your hands, your Council would draw your attention to what appears to them to be a slight omission in the general rules of the Association, viz., a provision for the retiring of part of the Council at the end of every year, and they suggest that half their number should remain in the Council, the number of meetings each member has attended during the year determining who these shall be. Your Council may make another suggestion for your consideration, viz., the desirability of opening a correspondence with other photographic societies, especially those more immediately in our neighbourhood, with a view to the interchange of information and discovery. In the year that has passed much has been done towards the general advancement, from the American ghosts of our photographic friends at Boston to the more tangible ghosts of Professor Pepper in London. Globe lenses have been introduced, but it is doubtful if they exceed the triplet either in the straightness of their lines or speed of action, while the cost of the former far exceeds the latter. The Great Exhibition has closed, but it is doubtful if it has done much towards the advancement of photography, its treatment of which has certainly not given universal satisfaction. New processes have been introduced, amongst the most important of which may be mentioned the fuming by ammonia, and sulphocyanide fixing in the printing process, for which latter new papers have also been introduced in alabastrine and enamel, both producing beautiful results in the very high glazing of their surface, though not without difficulties in their manipulation. Great advancement has been made in the production of solar pictures, in the construction of apparatus for which much yet remains to be done. Copying and enlarging by transparency has also received its share of attention and been helped on its onward course. The application of photography to the lithographic process has been an object of not altogether unsuccessful research and experiment. Many new formulæ have been introduced with the view of insuring greater rapidity of action, and amongst all the progress that has been made, your Council think they may safely say that the first year of the existence of the Glasgow Photographic Association has not passed away without its

contributing its atom (however small) to the general advancement of the art.

The report having been unanimously adopted, and votes of thanks awarded to the officers for the past year, the following were elected for the ensuing year:—

President, John Kibble.

Vice-Presidents, J. Jex Long, and John Stnart.

Treasurer, Archibald Robertson.

Hon. Secretary, Edmund Brace.

Council, Andrew Mactear, Alex. Macnab, James Ewing, J. Bowman, J. Spencer, jun., and Dr. Prichard.

The meeting then separated.

THE LONDON PHOTOGRAPHIC SOCIETY.

The first meeting of the winter session was held on the evening of Tuesday, the 3rd inst., the Lord Chief Baron in the chair. The audience was unusually large and animated.

After a few observations from the Lord Chief Baron, the minutes of a former meeting were read and confirmed.

A variety of interesting objects were laid on the table—negatives from rapid dry plates, by Mrs. Spottiswoode; illustrations of the working of Dallmeyer's triple lens, by Mr. Hughes; specimens by Ross; the presentation print of Mr. Robinson; the presentation print of Mr. Williams; Mr. Hart's volumetric apparatus, &c. From the all-absorbing interest of Mr. Smith's paper and specimen pictures, other objects obtained but little attention, and were not, in fact, brought before the meeting.

Mr. SMITH then proceeded to detail the history of the alleged photographs of the last century, explaining how the matter first came under his attention, and the evidence he had been able to collect of their production, and reading extracts from the various documents having any bearing on the subject. We shall give a full statement of the case in our next; meanwhile, to render the discussion intelligible, we may now briefly recapitulate. About a year and a half ago Mr. Smith was in Birmingham, making some arrangements on behalf of the patent Museum, for the loan of Watts' first engine. Whilst in communication with Mr. Price, of the Soho Works, whose family had been the agents of the Boultons for two or three generations, his attention was called to some old pictures of a curious character. These, it appeared, were found by Mr. Price nearly twenty years ago amongst some tons of old documents in the private library of Mr. Boulton, which had not been opened for about fifty years. They consisted of some curious pictures in monochrome on paper, and of two pictures on silver plate, labelled "sun pictures," one consisted of a view of Mr. Boulton's house before its alteration in 1791, another of the same house after its alteration. Various documents in Mr. Boulton's papers referred to a secret process of copying pictures, the invention of a Mr. Francis Edgington, and also alluded to the necessity, for some purpose, of suppressing this invention. An old man connected with the Soho Works remembered pictures being taken by the members of the "Lunar Society," with which Bolton, Watt, Wedgwood, Davy, and others, were connected; these were done in a dark room. He said that Sir William Beechey, who was painting Mr. Boulton's portrait at the time, induced them not to publish the secret, as "it would shut up all the painters' shops." As a corroboration of the old man's memory, it was found that Beechey did paint a portrait of Boulton at the time. A camera had been found with the papers, which had not yet been traced to its present owner, but search was being made. In addition to the evidence derived from the Boulton papers, Miss Meteyard, "Silverpen," who was engaged in writing a life of Josiah Wedgwood, had found in papers placed at her disposal two photographs, which, from the evidence she had, appeared to have been taken by Thomas Wedgwood in 1791, and allusion to the lenses, chemicals, &c., employed, was found in the papers. The details would be published in Miss Meteyard's book in February. Allusion was made to the use of nitrate of silver, and to obtaining an image with great rapidity, but full details could not yet be given. Mr. Smith very lucidly had all the evidence he had collected before the society, and asked them to help in the further purpose he had, which was simply to arrive at the exact historical truth of this interesting subject.

The pictures were passed round for the examination of members. Some consisted of reproductions of pictures in monochrome and colour, by Benjamin West, Angelico Kaufman, and other eminent names. These pictures were on paper, some very large, done in two pieces, and altogether unlike any class

of pictures we knew; of the two pictures on silver plate about 7 by 4, and of the two pictures by Wedgwood, one about 8 by 6, a view of a breakfast table, having much the appearance of a faded silver print, and another similar in appearance, a small reproduction of a drawing.

The CHAIRMAN in proposing a vote of thanks, which was carried by acclamation, made a few observations on the slow progress of a new discovery until experience had developed its useful application. After which he retired, and the chair was taken by Mr. Bedford.

Dr. DIAMOND stated that he had called the attention of Mr. William Smith, deputy chairman of the National Portrait Gallery, a gentleman who, perhaps, knew more about art and pictures, than any other man in England. He at once said that these pictures (referring to those on paper), were not produced either by engraving, drawing, or painting, or by any method of which he had any knowledge; they bore no traces of handwork whatever. Mr. Smith had also lent him a catalogue which seemed to have a singular connection with this subject. It was a catalogue of works exhibited by the Polygraphic Society at 381, Strand, who had a method of copying pictures by Chemical and Mechanical Means, invented by Mr. Joseph Booth. The catalogue called attention to certain duplicate copies of pictures to prove that they had not been produced by hand, and also to the fact that the pictures would be ready for distribution during the summer, a very photographic kind of allusion. This Mr. Booth was a portrait painter of Lewisham, Kent, and there was a singular circumstance connected with a patent he obtained for manufacture of cloth, &c. He obtained an Act of Parliament, enabling him to secure his patent without divulging his secret, the specification being examined by two masters in Chancery, who were sworn to secrecy. It was quite possible that the " &c." might include this process of copying pictures. The catalogue had no date, but the collateral evidence pointed to 1792 or thereabout.

Mr. SMITH read an extract from the Patent Records, and a conversation ensued on the want of evidence of identity or connection between the polygraphs and those described by Mr. Smith.

Mr. P. LE NEVE FORSTER referred to the discrepancy between the published statement of Wedgwood and Davy in 1802, that they were unable to fix the images they then obtained, and the statement that Thomas Wedgwood produced the picture now before them in 1791.

A desultory conversation ensued, in the course of which Dr. DIAMOND remarked that it was possible that the print might have been preserved in its present state by simple washing. The early pictures of Mr. Fox Talbot were, he believed, so preserved, and afterwards by solutions containing common salt and bromide of potassium.

The question as to whether the pictures were produced by means of a lens and camera was then discussed, a general impression prevailing that those on silver plate and those by Wedgwood had been so produced, and that it was doubtful as regarded the large paper pictures.

Mr. SMITH referred to the statement of the old man he had mentioned, that the image was thrown on to a table in a dark room and then fixed with some kind of chemical.

Col. STUART WORTLEY thought it was probable they were produced by drawing the image of the camera obscura, as M. Claudet did some of his enlargements.

Mr. CALEY said Colonel Stuart Wortley seemed to overlook the fact that Dr. Diamond had already quoted opinion of a high authority, that these pictures bore no trace of such hand-labour, which M. Claudet's undoubtedly did. He had had an opportunity of speaking with Mr. Smith on the subject, than whom a more capable judge, it was well known, could not be found, and he expressly stated his conviction that such pictures would not be produced by impressions from steel, copper, stone, or other substance, nor by any method of drawing by hand. Mr. Smith had, perhaps, the most perfect collection of catalogues of sales and exhibitions of paintings in every part of Europe, arranged in chronological order, and his opinion of the date of Mr. Booth's exhibition was very valuable. It would seem that, in addition to what was going on at Soho, there was another, and distinct, although possibly similar process, going on elsewhere.

Colonel STUART WORTLEY asked if these pictures might not have been produced by some method similar to chromolithography.

Mr. CALEY said no; because the material and result bore no resemblance.

After some further conversation, Mr. SHADBOLT said, whatever opinion might be formed, as regarded the paper pictures, the silver plates were, in his opinion, unquestionably photographs. He had examined them carefully with a lens, and he was assured they were camera images from nature, and not copies of any kind of drawing. One of these, then, it appeared, took back the invention of photography to a period before 1791.

Mr. DEBENHAM called attention to the spots on some of the prints which had light and shadow, just as a photograph would have if spots or roughness existed in the original.

Mr. MALONE had examined them, as suggested, and came to the same conclusion. To refer to the paper pictures first:—The person to whom the invention was now referred, Mr. Edgington, was, it appeared, a person who was in the habit of painting, and from his allusions to the "dead colour," and "retouching," he saw no reason why these pictures should not have been produced by the brush. He saw nothing to connect them with the operation of light, and it was a gratuitous assumption that they were in any sense photographs. The fact that Boulton, Wedgwood, Davy, and others, were members of this Lunar Society, militated strongly against the supposition that light was employed, when they found Wedgwood and Davy years afterwards saying they failed to get an impression in the camera on account of the feebleness of the light. There was nothing to connect them with photography, and he did not believe they were photographs at all. Next, as to those attributed to Wedgwood. An impression prevailed that Josiah Wedgwood, the great potter, was also the photographer. Such was not the case. It was his uncle, Thomas Wedgwood, and it was this gentleman, who, with Sir Humphrey Davy, stated, in 1802, that no method of fixing sun pictures had been discovered. These pictures, certainly, or at least one of them, appeared to be a photograph, and reminded him of some of Mr. Talbot's early pictures; indeed, he had seen some of them with just the same objects. So far as he could see there was nothing to connect the pictures exhibited with the early date assigned to them. Then, with regard to the pictures termed Daguerreotypes, he must confess that with his knowledge and experience he should be afraid to call them Daguerreotypes, as some of the early pictures of Niepce, on metal, bore a startling similarity to the former. He had not carefully examined them, as it would require a better light to determine whether they were copies of drawings and not pictures taken with the camera before 1791. He felt that the evidence had entirely failed, and that if the matter had fallen into the hands of a photographer for examination, they would never have been brought before a photographic meeting, or have had such claims made for them. He sympathized with the gentleman who had shown such earnestness in the matter, but, as by admitting such unfounded claims they were detracting from the credit of gentlemen to whom the discovery belonged, he felt bound to protest against it.

Colonel STUART WORTLEY expressed a conviction that they might have been taken 15 years ago from a drawing.

Mr. MALONE: Precisely so. There were many other difficulties to be got over in supposing the use of a lens sufficiently perfect for the work. A gentleman, who he regretted was not present, and who, perhaps, was absent through motives of delicacy arising from his nationality, had remarked that iodine was not discovered until after the alleged date of these pictures, and that it seemed a miracle if it were possible for two distinct processes of photography to be discovered at that date, and then lost sight of.

After some further conversation, arising out of suggestions by Colonel STUART WORTLEY, that the alleged paper photographs should be compared with the original paintings,

Mr. SMITH reminded Mr. Malone, that he had not called the pictures on plate Daguerreotypes, but merely "sun pictures." The term Daguerreotype had been used by others, because of the similarity these pictures bore to Daguerreotypes.

Mr. SHADBOLT said, that if the pictures on silver plate were examined by the aid of a lens, it became clear beyond a doubt that they were produced with a lens and camera, and from nature, and as one was produced before the alteration of the house in 1791, there was a conclusive fact.

Mr. MALONE had not so examined, but would take Mr. Shadbolt's word, and pass that by; still, it did not prove that they were not produced at a later date.

Dr. DIAMOND said they were unquestionably from nature.

Mr. MALONE still did not see that the date was proved by that.

Mr. HART suggested, that some of the pictures which had

been thrown aside by Wedgwood, as not fixed, might have become developed by time since, and that one of these shown might have been in such case. In regard to the discovery of iodine, the chemists of that time had barilla, from which iodine was obtained, and might in some way have used it.

Mr. SMITH expressed a conviction that some of the pictures had become more developed, even whilst in his possession.

Dr. WRIGHT was glad that Mr. Malone had, by admitting that the silver-plate pictures might be photographs, given up his ease. They had, however, the evidence of Dr. Diamond, with whose opinion that of Mr. Malone could not, of course, be compared, that these were veritable photographs from nature, and one of them of a house which was pulled down in the year 1791.

Mr. MALONE feared he had not made himself understood. He had not examined the pictures, so as to come to a conclusion himself; but admitting or passing by that question, he did not see anything to prove the date when the picture was taken. It appeared to have been assumed on the hearsay evidence of an old man now dead.

After some further conversation, Mr. MALONE still expressed himself not satisfied, but at the same time fully appreciated the earnestness with which Mr. Smith had examined the matter, and hoped, if any word of apparent disrespect had escaped him, that Mr. Smith would accept his hearty apology.

Mr. PEARSALL had seen, at the Royal Society, the specimens which Wedgwood and Davy had explained, they could not fix. He remembered seeing in a somewhat rare volume—the *Journal of the Royal Institution*—an allusion by Wedgwood to the fact that the process might be of use for copying pictures on glass, and he remembered hearing Mr. Wedgwood regret the want of good means of fixing, arising probably out of his knowledge of some means of using it commercially. He next referred to the extraordinary effects which the Birmingham japanners and painters could produce in copying. He also added that those familiar with manufacturing houses could quite understand how a secret could be maintained, and even allowed to die out, rather than be communicated, if it were understood in the house that it was a secret.

Mr. JABEZ HUGHES suggested the importance of securing the camera as a link in the evidence. He thought at present all the exact evidence rested on the metal picture. Dr. Diamond and Mr. Shadbolt, two gentlemen eminently qualified to judge, had carefully examined the picture, and believed it to be the genuine production of a lens and camera, from nature. Mr. Malone had not examined it, but doubted it. The former gentlemen reasoned from their knowledge, the latter reasoned from his ignorance. It was not hard to decide whose opinion was in such case most valuable. The matter had been very carefully brought before them, and fresh evidence was promised. They had now to withhold a fixed judgment, but wait for fresh evidence. Unquestionably, there was a very strong *prima facie* case, and they were much indebted to the gentleman who had taken such pains to bring it before them.

The CHAIRMAN, after referring to the deep interest of the subject, and their indebtedness to Mr. Smith for the labour he had bestowed in collecting the evidence, announced that the beautiful reduced copy of Mr. Robinson's "Bringing Home the May" was a specimen of the presentation print, a copy of which members would receive early in the ensuing year. The Secretary would also hand to each member, on application, a very fine card portrait of their president, the Lord Chief Baron, which Mr. T. R. Williams was kind enough to present to the members. He proposed that the thanks of the meeting be offered to Mr. Robinson for his handsome gift of the negatives of the "May," and to Mr. Williams for the beautiful card portraits he had kindly offered to the members.

The thanks of the meeting to Messrs. Robinson and Williams for their gifts to the Society.

The SECRETARY announced that at the next meeting a paper would be read on "Photography in its Application to Military Purposes," by Mr. John Spiller, F.C.S., of the Royal Arsenal, Woolwich.

The SECRETARY also placed two bottles on the table, and read a letter from Mr. Malone, explaining an experiment on the photographic image. He had taken the blackened substance which constituted the photographic image, mixed it with gelatine, and then treated it with hypo. He afterwards submitted it to hot nitric acid, which did not, contrary to his expectation, dissolve it.

After a few words from Mr. MALONE, which were inaudible, from the meeting commencing to rise,

The SECRETARY said there were various other matters which had been intended to bring before the meeting, which, at this late hour must, however, stand over.

Mr. C. HANBURY then hastily illustrated the working of a washing apparatus, and

The proceedings terminated after 11 o'clock.

Correspondence.

FOREIGN SCIENCE.

[FROM OUR SPECIAL CORRESPONDENT.]

Paris, November 4th, 1863.

A LIVELY dispute is going on between Messrs. Marquier and Mirvan, respecting the priority of the photolithographic process submitted to the academy by M. Mirvan. In support of his claim M. Marquier submits—1st, an official copy of the specification of his patent and of those taken out by M. Mirvan. 2nd, of a certificate attesting that in May, 1862, he sent to the Great Exhibition of London a frame containing proofs taken by his process. 3rd, of a letter from M. Husson, brother-in-law of M. Mirvan, declaring that in the impossibility of his obtaining satisfactory results, he desired to enter into communication with M. Marquier, and negotiate for the purchase, wholly or partially, of his discovery. It is true that the patents and additions of M. Mirvan are anterior to M. Marquier's patent. But the process presented to the academy by M. Mirvan is not the process described in his second and last addition; it is simply and purely, with two slight differences, M. Marquier's process. M. Mirvan has merely substituted gelatine for gum, and bichromate of ammonia for bichromate of potassa.

M. Poitevin has published in *Les Mondes* the following letter on the matter in dispute:—

"In the interest of truth, I believe it to be my duty to protest against M. Marquier's pretensions to the invention of a new process, and especially against the validity of the patent he took out on the 18th of June, 1862, for working this kind of printing in France, which he realized at Cuba, in 1861.

"According to the description given, he employs, for photographing on stone, the bichromates and gummy, or gelatinous organic matters.

"On the 27th of August, I took out a patent precisely for this very application of bichromatized organic matters, and, consequently, I anticipated M. Marquier's patent seven years. As is well known, my patent has been constantly worked; and, moreover, my invention has been recognized and appreciated under many circumstances, which I believe it is unnecessary to mention here.

"Rest assured, Mr. Editor, that it is in the interest of both parties that I make these observations, and that I have no other desire than to avoid disputes in future, always vexatious, to which the working of M. Marquier's patent must give rise."

On this letter the Editor of *Les Mondes* has the following remarks:—

"We are not called upon to decide upon the differences already noticed between M. Marquier and M. Poitevin's processes. It is not for us to say whether these differences are sufficient to warrant a new patent; but we may say that in the way M. Marquier views the matter (who, moreover, has no intention of working his patent commercially), that the possibility of his operating with a negative instead of a positive, which M. Poitevin has necessarily required—constitutes a truly essential difference."

M. Gammé has made some suggestive remarks upon a phase in landscape photography well worthy of being carefully tested. He says that frequently, when taking a view of an edifice, or landscape, or other object, during the afternoon, that the portion upon which the sun's rays had shone

during the morning, but which, at the time of photographing it, was in the shade—this portion, he says, came out in the picture with much more detail than if taken in the afternoon when the morning rays of the sun had not shone upon it. In the first case, the detail has come as well in the shade as in the light, without a very long exposure; in the second, it seems as if the shade was more opaque. Is this an error, or is it to be attributed to the phosphorescence of objects, or storing up of light, which has been so ingeniously suggested by M. Niepee de Saint Victor? Can it be retained in the objects so long? What induces me to believe so is, that if it happens to rain between the time upon which the sun has shone upon the objects and the time of photographing the same, the effect described no longer takes place, for the shade lacks detail; it would seem as if the rain washed out the light from the object.

MOUNTING PHOTOGRAPHS.

Sir,—As every hint of a practical nature may be of use to some one or more of your numerous amateur readers, I send you my mode of mounting proofs, which I have long found easy and successful.

Into a small beaker glass I put 2 ounces of cold distilled water, and place in it 48 or 50 grains of Cox's refined gelatine. When this is sufficiently softened (usually whilst I breakfast), it is heated by a spirit lamp till entirely dissolved, and the solution is then placed in a common jelly-jar, filled with boiling water to maintain its fluidity. The mounts being ready, I sponge them lightly with cold water on the face, and laying a print on a smooth pad of clean blotting paper, brush over it with a flat hog's-hair tool the solution of gelatine, crossing it in all directions till fully wetted, and taking especial care that the edges are so. When it ceases to curl or cockle and lies perfectly flat, I lift it carefully and place it on the damp mount, putting over it a piece of clean blotting-paper, and then rub it down firmly with an ivory folding-knife, commencing at the centre and proceeding thence to the edges and corners. Unless the paper be very thick, it will at once adhere firmly, but should a corner not do so, I gently raise it and apply a little more gelatine, rubbing it down again forcibly with the paper-knife, the blotting-paper being of course interposed. In this way I find it easy to mount prints of every size, from that of a carte to landscapes 12 by 10 in. When nearly dry, I place them face to face, with a sheet of clean writing-paper between them, under a weight till entirely so. A pile of books, or a board and a few iron weights answers the purpose.

If this is at all likely to be useful, its insertion will oblige your occasional correspondent,

ALIQUIS.

GLASS HOUSES AND DISTRICT SURVEYORS.

Sir,—I have just learned something by experience, though nearly too late and at too great cost. In removing my glass-house to more commodious premises, where I get all the sun for printing purposes, I was not a little astonished at receiving notice from the District Surveyor to pull the same down when nearly complete. He called it a wooden house, though at least three-fourths are glass. I went on with the work, however, and at last the Surveyor came and stopped the workmen, telling them they were subject to a fine of fifty shillings or a month's imprisonment. This has left me helpless. I was under the impression that a house not having foundation, or attached to the dwelling-house, would pass. However, I find now, to my loss, that such is not the case. Some time back there was a drawing of a house in the NEWS, a very low sum being stated for the erection of the same; but it would not be allowed, and I therefore send you the following information:—All such houses as are used for photographic purposes must be, where no brickwork is desired as foundation, composed of the following parts:—Glass-frames, sashes, and doors: no walling must be attempted by boarding up any part, or it will be called a wooden house, and thereby be subject to come

down. Now, I am aware of many an honest man thus nearly ruined by being compelled to pull down his glass-house, or go to some very great expense to meet the law. I therefore thought I would send you a line or two on the subject, leaving it to your own discretion to do with the same as you might think fit. Believing something inserted in the NEWS to this effect would prove welcome to many who have never seen the Act, led me to write this hasty sketch. Believe me, Sir, yours very obediently, G. R. GILL.

43, Islip Street, Kentish Town, Oct. 28th, 1863.

[We believe that the arrangements to which you refer, vary in different districts, according to the Act of Parliament under which they are locally governed. In all cases the District Surveyor should be consulted prior to commencing any erection.—ED.]

Talk in the Studio.

COLLODION FOR WOUNDS.—Mix one part of crystallized perchloride of iron gradually and with care, so as not to boil, with six parts of collodion, and a good hæmastic for wounds, leech-bites, &c., is produced. The composition should be of a yellowish red; it is perfectly limpid, and produces a yellow and very elastic pellicle. This hint to surgeons comes from Antwerp; it might be useful also to men who shave either themselves or others.—*Scientific American*.

THE DOUBTFUL LIKENESS.—The Paris correspondent of the *Daily Telegraph* is either a photographer, or an admirer of the art, as he constantly makes allusion to its varied use. He gives recently an anecdote of a portrait which was evidently not a striking likeness:—"Appropos of photography, last night one of the corps de ballet at a small theatre here was showing her portrait under which she had written in large characters her name and address. "Do you think it like, Fifine?" she asked of one of her sister-danseuses. "You forget I can't read," was the doubtful compliment to the artist. But the story does not end there. Fifine, laughed at for her ignorance, was determined to re-establish her character. "Come with me, and I will show you the autograph of Victor Hugo," said a friend, a few minutes later. "Oh, how I should love to see it; is it like?" was the exclamation of the unlucky Fifine.

CLUB PHOTOGRAPHS.—The same authority, speaking of a new Jockey club, in Paris, says:—"The only novelty I have as yet discovered in this new institution is that the photographic portraits of all the members of the club are displayed in one part of the entrance-hall so that the wearied tradesman or irritated creditor may sit and frown at the copy while waiting for the original. Let us hope, too, that the members as a body are good looking, for to pass through a "Chamber of Horrors" would spoil any dinner. Besides, such awkward remarks might be made, of the same sort, for instance, as that which was recently made by an English nobleman to the Emperor of the French, who, knowing my lord to be a soldier, had treated him to a review—a display perfectly thrown away on the "worst officer."—I quote the adjutant in her Majesty's Lifeguards—Green. "Well, Lord —, what do you think of my soldiers?" Well, Sir, I think they are the very ugliest lot I ever saw."

BLACKING THE BRASS WORK OF LENSES.—One or two correspondents have recently asked for information as to the method of producing the black colour on the polished part of lenses, stops, &c. The dead black may be produced in various ways, the simplest being the application, cold, of a mixture of lamp-black and common spirit varnish. This will, of course, rub off with friction. The polished black is produced by what is termed "chemical bronze," which is generally supplied by chemists ready for use, each maker probably having his own precise formula for its preparation. It simply consists, we believe, of a dilute solution of bichloride of platinum. The best strength we cannot state, as we have not had occasion ourselves to use it. Bichloride of platinum is prepared in a manner similar to chloride of gold, by acting on the metal with nitro-hydrochloric acid; the acid solution is then evaporated to dryness, which leaves a reddish brown deliquescent substance readily soluble in water. If used too strong, its action is too rapid and corrosive; if too weak, it refuses to act at all, especially on some samples of brass. It is best applied to the metal immediately after turning, so as to have a chemically clean and untarnished surface. It is applied with a camel's hair pencil. When the operation is complete, the surface is brushed with a little black lead. [Since

writing the above, we have been furnished with the following formula:—4 drachms of bichloride of platinum, 1 grain of nitrate of silver, in 6 ounces of water. This is said to answer well.—Ed.]

THE TRIPLE LENS.—The following remarks by the Editor of the *Journal of the Bengal Photographic Society*, furnish gratifying proof that the opinion we have always expressed of this lens find full confirmation in India:—"The use of triple combination in lenses for ordinary landscape work has become so common, and, in some respects, possesses such advantages, that we shall make a few remarks on the subject, in the hope that they may be of use to some of our readers. The favourite form of lens at present is the triple combination, the advantages of which are that—*first*, it includes a larger horizontal angle than the old single lens; *second*, that it gives greater depth of focus with a large aperture; *third*, the focal length is about one-fifth less, which, combined with the possibility of using a full aperture without any very serious falling off in definition towards the edges of the plate, make up a total of advantages not to be found in any other lens. The introduction of this form of lens has rendered instantaneous photography, on a tolerably large scale, possible, and the photographic world is indebted to Mr. Dallmeyer for this and many other valuable improvements in the form and principle of photographic apparatus. We have recently tried some experiments with a triplet lens by this maker, stated to be for plates 10×8. The focal length is a trifle under 12 inches, and we find that, with the middle stop it gives fair definition to the edges and corners of a 12×10 plate. We confess of being greatly astonished at this, for the idea that a lens could be made to cover a plate equal to, or exceeding its own focal length never entered our imagination. An old landscape photographer will not fail to see the immense advantage gained in angle by what we have stated, and we shall take an early opportunity of exhibiting a picture which we hope will make the gain apparent. The actual angle included by the above lens we find to be as nearly as possible 45 degrees, or 10 degrees more than the old lens gave. This is a gain of nearly one-third, combined with such an increase in rapidity that, with ordinary skill, there is nothing to prevent any good photographer from taking instantaneous views of the sea, and landscapes generally, with figures and life in them, such as no skill, however great, could possibly have accomplished a few years ago. Looking at what has been done in a few years, we do not despair of seeing lenses made which will include a still greater angle, and give instantaneous pictures upon plates 15×12 or even larger. Increased rapidity is more to be hoped for in the optical than in the chemical branch of photography, for it is difficult to conceive anything more sensitive than the collodion film. All that it requires is a free admission of light, there is plenty outside, but we have hitherto been obliged to shut it out to meet focal difficulties."

To Correspondents.

- J. W. R.**—There is no especial work published in this country on card pictures. The various recently published manuals contain information on the subject, and our pages contain all improvements and modifications made from time to time. Our ALMANAC, which will shortly be published, will also contain special advice on the subject.
- H. T. B.**—We prefer the interior of the dark room to be black or a dark colour, so to reflect the least possible light, if it by chance get in unobserved. 2. The acetate toning bath most readily gives purple black tones.
- A PUPIL OF THE NEWS.**—The splitting of the film may proceed from many causes. Imperfect cleaning of the plate, or coating it when slightly damp, will cause it; under-exposure and over-developing and intensifying is a very common cause; an acid bath is favourable to it. Clean the plates well, and use them quite dry, expose sufficiently, do not dry the plate by the fire, but let it dry spontaneously. The cause may be sometimes in the collodion; but we think not in this case.
- DEKLA.**—If negatives are kept in a dry place, with blotting paper between, they will not suffer injury. 2. If you add sufficient common salt to your washing waters you will throw down all the silver. Rapid agitation and the addition of a little nitric acid will aid the entire precipitation. 3. Gum may be used for mounting if used fresh, but it is apt to become acid and dangerous.
- E. S. D.**—We prefer No. 2, as being more rapid in action and giving greater depth of definition. We think its superiority is worth more than the difference in cost.
- HENRY NUTTS.**—The proposed plan of your glass room appears very good. Let the glass in the sides be continuous and not divided by a space of wood.
- C. W. F.**—The cuttings from fixed prints do not contain much silver; but we believe they are worth about fourpence per pound. 2. The residues of developing solutions contain silver sufficient to repay preserving them.
- J. J.**—Mr. Pouncy is the only person who undertakes the process in printers' ink at present. We do not know his charges. Probably Mr. Dallas's process will give you the best results of any photo-engraving process.

- G. S.**—The glass received is not a true orange tint, but a brown. It would not be perfectly safe in a strong light.
- G. W. O.**—If the opal mullage be in the habit of turning acid, as your second experience indicates, it is certainly not safe for photographs, and it is right, as you say, that the caution should be given.
- J. L. PRESTON.**—For purple tones, we prefer the acetate bath, and for deep blacks, the lime bath, as we have recently described it. You must, to get good tones, have a good negative and print and tone deeply.
- A CONSTANT READER.**—Methylated spirit may or may not be pure of its kind, different samples having different qualities. Spirits of wine should not be used in albumenizing paper at all.
- LUX.**—There is no danger of a preliminary coating of India-rubber injuring the nitrate bath. 2. The dark slide is not likely to injure a tannin plate when dry, unless the wood be sufficiently new to give forth some resinous smell. 3. A half-dried plate put into the slide will assuredly have a mark, as the rate of drying or evaporation is checked, and a different result produced.
- T. C. CONSTANT SUBSCRIBER.**—If your negatives fit your printing frame tightly, that would unquestionably be an occasional source of cracking, as sufficient room for expansion in changes of temperature is desirable. We have occasionally known such a thing as a negative cracking in the printing frame, but not often. It generally arises from some unequal pressure as well as change of temperature. See that the frames are not warped, and that the pressure is true and even, and use thin patent plate. Also do not subject the glass to greater change of temperature than you can help. 2. Reproducing a negative by means of superposition on a dry plate will have a greater tendency to give hard results than by reproducing on wet plates in the camera; if you use the dry plates, be careful to avoid under-exposure. 3. Stop out the spot in the wax-paper negative by using a little opaque water colour. 4. Metallic spots are generally a defect in the original paper; a fresh sample is the best remedy. 5. A bright red heat, approaching whiteness, is necessary to melt chloride of silver when a proper flux is present. Metallic silver is said to require a white heat, or a temperature of about 1,873° Fah. to melt it.
- HENLEY.**—If the deposit be sulphide of silver, which is probable, nitric acid will dissolve it, forming nitrate of silver and sulphate of silver. If it be gold, which is possible, a mixture of nitric and hydrochloric acids will dissolve it.
- NOTTS.**—Your design seems very good. We should place the background at the west end; and choose angle No. 2 for the pitch of the roof, as most likely to give a satisfactory light.
- OPEN AIR PHOTOGRAPHY.**—Where a tent or dark box is available, we should prefer wet plates. The chief advantage of dry plates is portability.
- HINDOO.**—Take out some collodion iodized, and some plain. A good bromo-iodized collodion, with cadmium, will keep for years in this country; how long in India, we are uncertain; possibly, if kept in full bottles in the dark, twelve months. If you are skilled in preparing your own collodion, by all means make it there; pyroxyline will keep for many months, sometimes years; do not keep it air-tight. The paper will be almost certainly read at the next meeting. You can receive the NEWS regularly in Bombay; your best plan will be to subscribe here before starting. Communicate with our publisher.
- E. S.**—We have not ourselves tried the especial formula, but we have worked enamel paper on still weaker baths with success. Probably there is some difference in the samples of enamel paper employed.
- PARVUS.**—Any good collodion, yielding a fine textureless film will answer for microscopic photographs, but we cannot certainly tell you whose sample is most suitable. We have seen some which would answer, of Keene's. Do not dilute with ether only, but with absolute alcohol as well. The addition of a little tincture of iodine will be an advantage to most samples.
- GETTSBURG.**—Ebonite, as made by Silver and Co., has proved, in our hands, very satisfactory, and has not contaminated the silver bath. 2. It is very strong and tough. 3. It is a form of vulcanized india-rubber submitted to peculiar treatment. The greater part of the sulphur employed in vulcanizing is subsequently eliminated by exposure to great heat. 4. It is very easy for each purchaser to get his ALMANAC bound; but we are not sure that it will answer the purpose of our publisher to issue any so.
- T. RATCLIFFE.**—We will forward the letter, and hope to get more information.
- A. BROTHERS.**—The print and stamps have been handed to our publisher, and will receive due attention.
- W. ABERDEEN.**—We have answered your question in another paragraph. You have simply to evaporate your acids, and the residue is the chloridic; there is no nitrate formed, the nitric acid simply aiding the operation; Use the solution dilute; the exact strength we cannot state; a few experiments will inform you.
- R. C. LOBB.**—The print you have sent us is most charming, and proves the skill and taste of the photographer, as well as the excellence of the chemicals.

Several Correspondents in our next.

Photographs Registered during the Past Week.

- MR. JAMES BURKE, 44, Lower Ormond Quay, Dublin,**
Photograph entitled "Postage Stamps of Great Britain and the Colonies."
- MR. WILLIAM GUTHRIE, 23, Nuns Street, Newcastle-on-Tyne,**
Photograph of Miss Emily Miller.
Photograph of Miss Fanny Addison.
- MR. EDWIN HARRISON, 42, and 43, High Street, Newcastle-under-Lyne,**
Photograph of Officers of the North Staffordshire 1st Battalion of Rifle Volunteers, 1863.
Two Photographs of the Champions of Staffordshire, Enfield and Small-bore Rifles, 1861-2-3.
Photograph of the Shooting Twelve of the North Staffordshire 1st Battalion of Rifle Volunteers, 1862.
Photograph of the Shooting Twelve of the North Staffordshire Rifle Volunteers, 1863.
Photograph of the Shooting Twenty of the North Staffordshire 1st Battalion of Rifle Volunteers, 1863.
- MR. ADAM DISTON, Leven, Fife, N.B.,**
A Photograph representing Alexander Selkirk's first day on the Island of Juan Fernandez.
- MR. THOMAS TYLER, 28, Trinity Street, Bristol,**
Photograph of a Monument to the Memory of Heneage, son of Lady Freeling.

THE PHOTOGRAPHIC NEWS.

VOL. VII. No. 271.—November 13, 1863.

CONTENTS.

	PAGE
The Story of the Early Photographs	541
The Winter Session of the Societies—Papers to be Read at the Usual Monthly Meetings During the Session.....	543
Saving the Silver—Shaw's Apparatus for Saving Silver and Gold from Waste Solutions	543
Photographic Chemicals	544
Researches on Positive Printing—Toning. By MM. Davanne and Girard	545
On the Behaviour of Chloride, Bromide, and Iodide of Silver in the Light, &c. By Hermann Vogel	546
On the Collection of Residues of Silver and Gold in Photographic Ateliers. By Dr. D. Van Monckhoven	547

	PAGE
On Photography in India. By W. H. Warner	548
Experiment—Pinholes	549
Hints to Operators—A Gold Toning Process	549
Celestial Photography	550
Correspondence—Foreign Science.....	550
Photographic Notes and Queries—Pyrogallic Acid and Formic Acid Preservative—Electric Light for Photography—Oil for Troubled Water	551
Talk in the Studio	551
To Correspondents	552
Photographs Registered during the past Week.....	552

THE STORY OF THE EARLY PHOTOGRAPHS.

THE history of the photographs supposed to have been produced half a century before the recognized birth of the art, and which, some six months ago, we had the pleasure of first bringing under the notice of the photographic world, is not yet completed. An interesting narrative, affording strong presumption of the legitimacy of the claims made, has been given to the public; but, as yet, some links are wanting in the evidence before it can be admitted to have the force of absolute proof. We shall here briefly put the statements of Mr. Smith, which he confirmed by voluminous extracts from authentic and original documents, into a brief consecutive narrative for the information of our readers.

Before doing so, we must call attention to the somewhat singular fact, that there are three, if not four, distinct classes of pictures, each by a distinct process, and, probably, by a distinct person, each with more or less of evidence believed to be photographs, each believed to be produced in the last century, and all more or less associated with the same names of persons known to have interested themselves in the production of pictures by the agency of light. We have a picture on a silver plate, believed by competent judges to be an undoubted photograph from nature, of Mr. Boulton's house, alleged to have been pulled down in 1791, and a similar picture of the same house after its alterations. We have large pictures on paper, some three or four feet long, which are monochrome copies of paintings, by a process which the ablest judges of pictures assure us bears no resemblance to any known method of pictorial production. Both these and the former are found amongst papers in Mr. Boulton's library, stated not to have been disturbed for upwards of half a century. Then we have two pictures, alleged to be photographs, one of them undeniably so, found by Miss Meteyard, amongst the papers supplied to her as material from which to draw in writing a life of Wedgwood, the great potter. These two pictures are stated to have been produced by his son about 1791, and documents of that date refer to the lens, camera, and chemicals used in producing such pictures. Then we have again a catalogue of about the same date of an exhibition of pictures, called polygraphs, produced without hand labour, by "chemical and mechanical means." We have no specimens at present of these latter pictures, nor have any photographic claims as yet been made for them; but the allusion comes in as an interesting and collateral fact, which may bear upon the others.

Upwards of twelve months ago, Mr. Smith, Curator of the Museum of Patents at South Kensington, had occasion to visit the Soho Works, at Birmingham, on business connected with the exhibition of Watt's first steam-engine at the Museum. Whilst in communication with Mr. Price, the agent of the Boultons, a gentleman whose family has occupied the same relation to the Boultons for two or three generations, his attention was called to certain curious-look-

ing pictures, which Mr. Price had found about twenty years ago amongst old papers and lumber in the private library of Matthew Boulton, the said papers and library not having been disturbed for fifty years before. He also pulled out of a drawer two plates like Daguerreotypes, packed between two pieces of board. One appeared to be a plain plate; the other had the picture of a house, and was labelled "Sun Picture of Mr. Boulton's House before the Alteration in 1791," and also bore the initials "J. W." This descriptive inscription was written, it appears, by an old lady, a member of Mr. Price's family, who remembered the house before its alteration in 1791, and at once recognised it. The other plate had since been found to contain an image of the house in its present state. This old lady as well as another old retainer of the Boulton family, both now, we believe, dead, also spoke of remembering the picture being taken by placing a camera on the lawn. The old man referred to the production of pictures by members of the "Lunar Society" as a common thing; stating that they used a dark-room and threw the images on to a table, and fixed them by some chemical. He also stated that the practice was discontinued, and the secret suppressed, at the request of Sir Wm. Beechey, who was painting a portrait of Mr. Boulton, who said that its promulgation would "shut up all the painters' shops." This is, as Mr. Maloué remarked, merely the hearsay evidence of an old man now dead; but there is the singular corroboration of his veracity and memory in one respect in the ascertained fact that Sir Wm. Beechey was engaged at the time referred to in painting Mr. Boulton's portrait. Mr. Price also found, at the time when this library, with the dust of half a century, was first invaded, a camera, which was given away to someone, and for which the search instituted has not hitherto been successful. So far as these pictures on silver plate are concerned, little doubt appears to exist that they are photographs, and that they are from nature, not copies of other pictures. The examination of the images by capable judges, Dr. Diamond, Mr. Shadbolt, and others, aided by magnifying power, issued in a decision that they were the images given by a lens from a natural object, and not copies of any kind of drawing, which must always possess a distinct and conventional character. The only weak point in the evidence of the age and authenticity of these pictures, is the want of decisive proof that the picture is really a view of the house before its alteration; and that this alteration was made in 1791. These two points established beyond a doubt, and the evidence is already strong, there is no room, we think, for further question of the fact that photographs on silver plate were produced half a century before Daguerre's discovery. By whom is not yet well established.

In regard to the paper pictures, the question becomes more complicated and difficult. It is by no means certain that they are photographs. They are certainly not photographs by any process of which we have any knowledge. But whilst they are unlike any class of photographs, we know

on the evidence of the Deputy Chairman of the National Portrait Gallery, an undeniable judge of such things, that they are equally unlike any class of painting, drawing, or engraving we know; and there are certain presumptions in favour of their photographic character. They are in monochrome; they are reversed or left-handed, as camera copies would be; they were produced by a secret process, and produced cheaply; they were in the possession of and produced by persons who were known to be associated with early photographic research; they have certain minor defects, which suggest photographic operations; one of them being large, is produced at twice, on two pieces of paper, and the colour or tone of the two halves varies in the manner photographs so produced are so often seen to vary. They have no appearance of any kind of engraving or lithograph, nor any class of drawing or painting. They appear to be on a kind of albumenized paper, and the colouring matter or image wipes away readily and cleanly, having little coherence or adherence. Against the presumption of their being photographs, the argument of chief weight, to our mind, is derived from the perfect definition in pictures of such large size. If they are photographs, we have made no progress in reproduction, possibly retrogressed.

There are, however, some very singular facts in connection with them which seem almost inexplicable. That they were produced by some rapid, cheap, faithful, and secret process is certain, and that the secret was for some reason suppressed is equally certain. The process appears, from the documentary evidence read by Mr. Smith, to have been discovered by Francis Edgington, a person in the employment of Matthew Boulton. Various bills or invoices for copies of paintings, by popular modern masters, by this secret process, are discovered, and also allusions to a Mr. Barney, who finished these copies with colour so as to resemble the original paintings, the work appearing to have a tolerably extensive demand. That a certain, rapid, permanent, and cheap method of reproducing pictures should have been suddenly entirely suppressed and the secret suffered to die out, appears in the present day almost inconceivable. But such appears to have been the fact, and we next find a most singular document bearing on this subject. It consists of a rough draft of a letter, in Matthew Boulton's handwriting, with one name, often recurring, most carefully obliterated. This name can, however, be clearly made out to be Edgington. The letter is addressed to a noble lord, and refers to a proposed pension of £20 a year to be given to Edgington, in consideration of the suppression of his invention. Mr. Boulton deprecates this on various grounds. In the first place, the man is his servant, and has already been duly paid for his services by a regular salary; next, that the payment of the pension will have a tendency to keep alive in his mind a matter which it is desirable he should forget; next, that he can better bind him to secrecy by considerations of attachment and gratitude to his master, and rewarding him himself necessarily; and next, that he would like the reward proposed for his servant to be given to himself, proceeding to develop a little job that we are not called further to detail or comment upon here. Whatever the process, we have it distinctly set forth in the document, that for some reason arising out of interested motives the method had to be suppressed and the secret suffered to die out.

The evidence is silent as to the photographic character of the process, and we can only deduce that from the character of the pictures and from the associations and traditions connected with them.

The third class of pictures has been brought to light more recently, and through a different channel. It consists of the pictures, which, as we announced a few months ago, had been found by Miss Meteyard amongst the old papers furnishing materials for the life of Wedgwood, upon which she was engaged. There are two pictures presumed to be photographs: one of them is so undoubtedly; the other, a copy of a drawing, is more doubtful. The genuine one is a picture of a breakfast service duly set out; it looks like a faded

silver print on paper. Miss Meteyard believes that she has sufficient evidence to attribute these to Thomas Wedgwood, the son of Josiah Wedgwood, the potter, and that they were produced in 1791. Amongst the documents are allusions to a camera, lenses, and chemicals for the production of such pictures. For the full details we must wait, however, until Miss Meteyard publishes her volume, which will appear in the course of two or three months. The point to be established here is the date of production, and of that at present we have no direct evidence.

In 1802, we find Wedgwood (not the same member of the family to whom Miss Meteyard attributes these pictures, we believe) and Davy reporting in the *Journal of the Royal Institution*, that the images of the camera obscura were too faint to produce, in a moderate time, any effect on their silvered paper, and that the pictures they did obtain by using the solar camera, they were unable to fix, as the paper darkened in sunlight even after washing well in water. Mr. Peter Le Neve Foster objects that if Thomas Wedgwood had produced and fixed camera images in 1791, it is very strange we should have the statement made to the Royal Institution in 1802. Mr. Malone, who assumed the opposition on all points, admitted that one of these pictures was a photograph, suggested that it looked very like one of Mr. Fox Talbot's earliest pictures, and he thought he had seen a similar subject. Dr. Diamond informs us that he has since received almost a duplicate of the picture from Mr. Talbot. This part of the subject also awaits further evidence.

The catalogue of the Exhibition of Photographs, lent to Dr. Diamond by Mr. Wm. Smith, affords another singular illustration of the possibility of an invention dying out and being forgotten. Whether any direct connection subsists between these and the alleged photographs, remains to be seen. But here is a catalogue of an exhibition of paintings held in the Strand some time about 1792, in which a method of copying paintings by "chemical and mechanical means" is referred to. Attention is challenged to duplicates which prove by their identity in all respects, that they are not the product of hand labour. The process is the invention of a Mr. Joseph Booth, a portrait painter; and we find that about the same time he obtained a patent for a process which he did not describe, a special Act of Parliament being obtained for the purpose. The patent was supposed to be for a method of manufacturing certain fabrics, but whether it included picture making, there are no means of ascertaining with certainty. Here is another instance of a cheap and faithful method of copying paintings by chemical and mechanical means, which appears to have died out; and, although little more than half a century has elapsed since, as yet no specimens are forthcoming, and the matter appears to have been almost forgotten.

There is not at present any certain connection between the last-mentioned pictures and the alleged photographs; but between each of the three first-mentioned classes, distinct as they are, there is the connection arising from their association with the same names. Tradition speaks of the photographic experiments of the "Lunar Club," associated with which we found the names of Davy, Boulton, Watt, Wedgwood, Priestley, and other savans of the day. In one of the documents referring to Edgington's process, we also find allusion to certain of the pictures for Mr. Wedgwood; but we do not find any direct mention of the name of Watt, as had before been supposed.

At present, any definite decision must halt and await further evidence. There is a sufficiently clear *prima facie* case to afford a strong presumption and warrant further inquiry. We admit fully the apparent improbability of such a discovery as photography being made and then being suffered to sleep, perchance to die. But against this we have the fact that an important discovery of some kind was made and then suppressed. Besides, probability cannot be permitted to weigh against evidence, and upon sufficient evidence alone can the laurels of discovery be removed from the brows which have hitherto worn them. To Mr. Smith

all honour is due for the perseverance and industry with which he has pursued the inquiry to its present stage, and for the honourable and high-minded impartiality with which he has brought forward his evidence, presenting it in the spirit of the philosopher not of the partizan, seeking above all things to establish the truth. Possibly the most satisfactory plan at this stage of the proceedings would be for the Photographic Society to appoint a committee to assist Mr. Smith in the prosecution of the inquiry. We hope shortly to record the conclusions of further research.

THE WINTER SESSION OF THE SOCIETIES.

THE season having come round in which the various Photographic Societies hold their regular meetings, a brief hint or two, not so much novel, perhaps, as important, may be worth repeating. The Societies have done good work hitherto in aiding the progress of the art, and affording pleasant occasions of intercommunication amongst members. We are desirous of seeing them continue the good work, and, by systematizing it, become more useful, more pleasant, and, probably, more permanent.

One great failing in some Societies has been the absence of a definitely announced subject, upon which members could come to listen or to speak, prepared by previous thought and experiment. When members hear of the subject only when they reach the meeting and hear a paper read, the discussion must necessarily be desultory and uncertain. If, on the other hand, a subject be announced a month before-hand, it is the fault of members themselves if they do not secure an exhaustive discussion. But better still than preparing one month before another, is the plan of preparing for the whole session in advance. When this plan is adopted, a varied and complete range of subjects can be secured, and members can come fully prepared for a most exhaustive discussion, should the subjects require it. A programme of this kind need not exclude topics of current interest, arising during the progress of the session, from receiving attention. The stock subject of the evening will not, in many cases, evoke much discussion, and on most occasions, opportunity will occur for the passing examination of some subject of immediate interest, or for desultory conversation on a variety of minor photographic matters; after the five-act legitimate drama may come a lighter piece, or *divertissement*. An illustration of this system of providing a certain and definite subject for each evening in the session is furnished by one of the most energetic and active societies in the North. The Glasgow Society have recently issued their programme, which we will reproduce as an example for others:—

PAPERS TO BE READ AT THE USUAL MONTHLY MEETINGS DURING THE SESSION.

1863.	
October 23rd	"Improvements on the Solar Camera" (with Illustrations).—By JOHN STUART, ESQ.
November 11th	"The comparative value of the Daguerreotype—Collodiotype and Calotype—Photographic results (as regards Portraiture) in point of Beauty, Permanence, &c."—By JAMES EWING, ESQ.
November 25th	"Experiments in Development Printing."—By GEORGE SHADBOLDT, ESQ., of London.
December 9th	"On certain Rapid Dry Processes."—By THOMAS SUTTON, ESQ., of Jersey.
1864.	
January 13th	"The application of Artificial Light to Photographic Purposes" (with Illustrations).—By J. W. STONE, ESQ.
February 10th	"Iron Developers and Intensifiers."—By G. WHARTON SIMPSON, ESQ., of London.
March 9th	"About Printing and Toning."—By C. JABEZ HUGHES, ESQ., of Ryde, Isle of Wight.
April 13th	"Chemical Combination and Decomposition."—By DR. WALLACE.
May 11th	"On Copying and Enlarging" (with Illustrations).—By ALEXANDER MACNAB, ESQ.

Other Important Papers on various interesting subjects are promised, for which extra Meetings will be arranged, and the dates thereof duly announced.

It will be seen here that for other important subjects extra meetings will be convened, so that nothing interesting will be excluded by having stock subjects arranged. An excel-

lent method to aid in securing papers is furnished in a bye-law of one of the London Societies. It is to the effect that each member of the committee is bound to provide at least one paper during the session. It is not necessarily imperative that he should read a paper himself, but he must do that or provide a substitute, so that the society cannot meet, as sometimes happens, without any subject whatever before them. It appears to us that, in any case, a paper should be provided and announced a month in advance, at least, and much longer where it is possible.

There is another change we should like to see. We should like to see the discussions more general and less confined to two or three persons. To secure the facilities and inducements for this, a little more attention to the recognised laws of debate is desirable. A very offensive feature of some meetings, we know, is the habit of one or two persons jumping up and speaking half-a-dozen times on the same subject, and that often with a captious motive or in a captious tone. This frequency and persistency in speaking, and this tone, have a most detrimental effect, in the first place, in not affording opportunity to less eager and apt speakers, and in deterring those who are more modest and timid. Long speeches are less common in photographic meetings; but there are occasionally speakers who do not know when to leave off, and exercise an injurious influence on meetings. We do not mean, in deprecating frequent speaking, to entirely condemn the conversational discussion, which is in some cases unavoidable, and often very interesting, or the necessary explanation which may arise, but the iterated and irrepensible speech-making which is so offensive.

There is another hint we would offer here to photographers at large, as well as to members of photographic societies, to aid in advancing the art. We should like to see every man with ability, or opportunity to do so, to take a speciality and master it. Let each one pursue the general practice of the art as duty or inclination may dictate; but let each one, in addition to this, take up a special subject in which to excel and become a master, and resolve to produce, say at least once a year, in time for the exhibitions, the very best specimen of that branch of which he is capable. Let them adopt, in regard to such speciality, the example of Mr. Robinson, of Cheltenham. He has adopted, as his especial aim, the production of artistic pictures by combination printing. He is engaged very closely in the active practice of his profession of portraiture; but in addition to that, one or more composition pictures have to be produced every year, as his direct contribution to the art progress of photography. Let each photographer adopt this principle of producing something yearly for the advancement of the art. There are many branches open: instantaneous photography, architectural photography, marine photography, the production of clouds and atmospheric effects, the production of foliage, flowers, and ferns, photographing animals, photographing specimens of various branches of natural history, microscopic photography, reproductions, enlargements, artistic and fancy printing, art studies, photolithography, carbon printing, &c. If every capable and enthusiastic photographer would systematize and give definite purpose to his effort, by adding to his general practice a special aim, and then exhibit his results and describe his methods, an impetus would be given to the art, and a beauty to its productions not hitherto obtained.

SAVING THE SILVER.

A REFINER in the United States has hit upon an ingenious idea to facilitate the preservation of a large proportion of the precious metal used by photographers, from waste and entire loss. He proposes to furnish to each photographer, and attach to the sink in his operating room, free of cost, an apparatus for reducing the silver contained in the water usually wasted by running down the sink into the sewers. At stated intervals the deposited residue will be removed

and reduced to the metallic state, three-fourths of its value will then be returned to the photographer, one-fourth being retained by the refiner for his share of the transaction. Here is the advertisement of the projector:—

SHAW'S APPARATUS FOR SAVING SILVER AND GOLD FROM WASTE SOLUTIONS.

According to many experiments made on this side of the Atlantic, as well as in Europe, to ascertain the amount of silver contained in *photographs, negatives, &c.*, it is found that a very large proportion of all the silver used is actually thrown away and lost, three quarters being the lowest estimate made of the amount thus wasted. Experience has taught that a large proportion of this useless waste of the *precious metal can be saved* by the use of the above apparatus, which has been in successful operation for the past year with good results. And I propose to put it in the hands of every photographer in the United States upon such terms as shall be practically without cost. I, therefore, propose to furnish the apparatus to every one applying for it, *free of expense*, who will set it up and follow the instructions for using it (which are very simple), upon the following terms:—

If I refine only such waste as the apparatus saves—hitherto a dead loss—I will return half the amount without cost of refining, my proportion to pay for rent of apparatus, use of patent, &c.

If, however, the operator will deliver to me *all scrap and waste* he can save by following my directions, I will refine it without cost and return three-fourths, retaining one-fourth for services, &c., as mentioned above.

By the last method I can return *MORE MONEY* to parties using my patent than they can possibly realize by saving in any other manner, even if they could refine the waste for nothing, as my invention will save a much larger per centage. My object in making this liberal offer is to remove all temptation to infringe my patent.

To carry out this plan, and at the same time to assure parties that they will be perfectly secure respecting their just share of the amount so recovered, I have associated myself with a *responsible party* well known to a large proportion of the photographers throughout the United States.

We commend the idea to some enterprising firm in this country.

PHOTOGRAPHIC CHEMICALS:

THEIR MANUFACTURE, ADULTERATION, AND ANALYSIS.

Zinc (continued).—Chloride of zinc is extremely deliquescent. When in the state of aqueous solution it is very valuable in the laboratory for small soldering operations. When soldering has to be frequently performed, it is convenient to employ a "soldering bolt," or "iron," which "iron" consists of a heavy lump of *copper* rivetted between two pieces of iron, ending in a rod of the latter metal firmly fixed in a wooden handle. The head is cleaned with sand paper, heated to a little above the melting point of solder, and then dipped into a strong solution of chloride of zinc. The solder is then rubbed on it, and it will be found to run over the whole surface instantly, the melted alloy *wetting* the copper as water will wet wood. In soldering any two pieces of metal together, the surfaces which are to be in contact are, first of all, well cleaned with a file, and then wetted with solution of chloride of zinc, or soldering fluid, as it is more frequently called. The soldering bolt is now heated, a globule of solder taken up by its point, and rubbed along the joint. The heat of the bolt will be sufficient to heat the surface of the metal, over which it is rubbed, to the melting point of solder, which will run along the joint and make it perfectly fast. For small laboratory operations, a soldering bolt is not generally necessary. Suppose, for instance, it is required to solder two pieces of tin plate together, it is merely necessary to place a few drops of the soldering fluid on the clean surface to be joined with a small scrap of solder, and hold them on a slip of wire gauze over a spirit lamp. As soon as the water has boiled away, and the residue of chloride of zinc has fused, the solder will melt and run evenly over the surface. The same thing is now to be done with the other piece of metal, care being taken in each case to limit the surface covered by the solder to those portions which are to be in contact. Upon now placing the two soldered surfaces in contact, and heating them for a few moments over the spirit lamp, the alloy will melt and unite the two together. Before they cool, the two pieces of metal should be firmly pressed in contact, and the excess of melted solder may, if desired, be wiped off while still liquid, with a cloth. When cold, the chloride of zinc must be well washed off.

Some persons recommend the addition of hydrochloric

acid, or chloride of ammonium, to soldering fluids, but we do not think anything is better than simple chloride of zinc.

Chloride of zinc will unite with chloride of ammonium, forming a double salt. A solution of equal atoms of chloride of zinc and chloride of ammonium being evaporated together in the presence of a little hydrochloric acid—added to replace the acid which may escape during the evaporation—yields, on cooling, transparent prisms which are permanent in dry, but deliquescent in moist, air. The crystals contain one atom of water of crystallization, and dissolve in less than their own weight of cold water.

Nitrate of zinc is of interest, as being the first substance applied to an excited collodion plate for the purpose of preserving its sensitiveness longer than a few minutes. By dissolving metallic zinc in nitric acid, there is formed, together with nitrate of zinc, a small quantity of nitrate of ammonia, which arises from the deoxidation of the nitric acid by the zinc and the union of the remaining nitrogen with hydrogen from the decomposition of the water. It is probable that the partial want of success experienced by some who followed Messrs. Spiller and Crookes' original process of preserving the sensitiveness of collodion plates, may be attributed to the presence of this salt of ammonia. The best way to prepare nitrate of zinc absolutely pure, is the following:—Take pure oxide of zinc prepared by precipitation, with the precautions mentioned in the last chapter on this subject, and dissolve it in nitric acid, taking care that the latter is in decided excess; now evaporate on a water bath until the solution is of a syrupy consistency, and allow it to cool. Nitrate of zinc will crystallize out in transparent, colourless, four-sided prisms. Separate these from the mother liquor by draining, and re-dissolve in water. Now evaporate again on the water-bath, and continue the evaporation until the salt appears dry, stirring it about constantly with a glass rod. The crystallized nitrate of zinc contains six atoms of water. When heated, it fuses, and at the temperature of the water-bath three atoms of water are evolved. The salt dried as above directed, contains therefore three atoms of water. Nitrate of zinc is very deliquescent, and is likewise soluble in alcohol.

Oxide of zinc dissolves in potash, and partly on that account metallic zinc will dissolve in the same liquid. When the zinc is free from any other metal, it dissolves very slowly, but when platinum or iron—preferably the latter—is in contact with it, hydrogen is evolved with some rapidity, and the metal quickly dissolves. The hydrogen gas so obtained is of value in many operations, as it is free from the sulphur and metallic impurities so frequently present in hydrogen gas obtained by dissolving zinc in dilute acids.

Cadmium is a metal which possesses many compounds of use in photography, especially the iodide and bromide. The metal itself is very similar to zinc in its chemical properties, and is generally found in ores of the latter metal. It is a white metal with a strong lustre, and intermediate in colour between tin and zinc. It has a dense texture, is soft, but harder and more coherent than tin; is easily cut with a knife, very flexible, and easily beaten out into thin plates, or drawn into wires. Its specific gravity is about 8.7, it fuses below a red heat, and volatilizes at a somewhat higher temperature. Commercial cadmium is very liable to be contaminated with zinc, for, being prepared by a rough manufacturing process from residues which contain a large per centage of the more common metal, it is not easy to effect the separation of the two with chemical accuracy. The best means of separating zinc from cadmium is to dissolve the metal in dilute sulphuric acid, taking care that the acid is present in considerable excess, and then to pass sulphuretted hydrogen through the acid solution. This precipitates all the cadmium as sulphide, whilst the whole of the zinc remains in solution. It is then filtered, and the sulphide of cadmium washed with plenty of water. It is then dissolved in dilute nitric acid, and the solution evaporated to dryness. The residue is dissolved in dilute hydro-

chloric acid, taking care to have as little excess of the acid as possible, and to the clear liquid, strips of pure metallic zinc are added. These precipitate the pure cadmium, as a spongy mass, which must be collected together, washed quickly, and fused in a crucible, under tallow or cyanide of potassium.

If the cadmium is required in the form of iodide or bromide, or similar salt, it is not worth while to reduce it to the metallic state, as much trouble may be saved by converting it into oxide. This may be prepared from the solution of the precipitated sulphide of cadmium in nitric acid. The filtered liquid is to be diluted with water and an excess of caustic potash added. This precipitates the cadmium in the form of hydrated oxide, which must be filtered, well washed with water, and dried at the temperature of boiling water. In this state oxide of cadmium is a fine white powder, containing one atom of water, which it loses at a red heat. It dissolves readily in acids, forming salts.

Sulphide of cadmium is largely used as a pigment, being of a very brilliant orange yellow colour. It is precipitated in flakes by adding hydrosulphuric acid, or sulphide of ammonium to a solution of a cadmium salt. It may be prepared of slightly different shades of colour, by varying the concentration of the solution and the temperature at which the precipitation is effected. The dry sulphide darkens in colour when heated, becoming first brownish, and when at a red heat, carmine red. It may be prepared in the dry way by igniting oxide of cadmium with sulphur, and then possesses a somewhat darker orange tint. It is not volatile at any temperature, but at a white heat fuses, and on cooling solidifies to a transparent lemon yellow crystalline mass. Sulphide of cadmium is very valuable as a pigment, owing to its unalterability under ordinary atmospheric agencies. Being already a sulphide, it is of course not attacked by sulphuretted hydrogen, and having no tendency to absorb oxygen under the influence of light or moisture, it is as near an approach to an absolutely permanent colour as the artist can hope to obtain. We are not, however, quite certain that it would be a safe colour to mix with tints which are altered by sulphur, as it is not unlikely that under these circumstances a double decomposition might take place in course of time, and some of the sulphur might leave the cadmium and go where it could commit havoc among the delicate shades.

RESEARCHES ON POSITIVE PRINTING.

BY MM. DAVANNE AND GIRARD.

TONING.

1. *Definitions*—In photography, the operation to which the name of *toning* is given has for its object the changing the hue of the positive proof, so as to place it in the best possible conditions of stability, and, at the same time, to impart to it an agreeable tint.

To obtain this result, the operator takes the proof either fixed in hyposulphite of soda, or simply washed on being removed from the printing frame, while still impregnated with all the insoluble salts, which have not been reduced by light, and immerses it in various solutions, where, by special chemical reactions, the effect he desires will be realized.

These various solutions may, by their very nature, be placed in two very distinct categories. In the first figures the salts, or even some imperfectly defined compounds, intended to act upon the silver in the proof, and change the original hue by a modification in the condition of that metal; these are the baths known under the name of *old hyposulphite, acidulated hyposulphite and hyposulphite charged with salts of silver*. In the second figure only the solutions of metals more electro-negative than silver, almost always gold, sometimes, but rarely, platinum.

We should examine successively, and from the two different points of view which the question of these two classes of solutions admits of, if our previous researches had not led us to reject the first absolutely, and to refuse to admit modified hyposulphites as toning agents. The cause of this rejection is also easily comprehended; according to our definition, the toning

agent must satisfy two *desiderata*: to produce upon the proof a colour agreeable to the eye, and to place the image in the greatest possible condition of permanency. Now, if, as in fact does take place, these toning agents can impart the agreeable hue to the proof so long sought for, and if, consequently, they satisfy the first *desideratum*, they are very far from satisfying the second. We have very clearly proved, in fact, both in the *general study of positive proofs*, and in a *mémoire* presented to the French Photographie Society, 19th of October, 1855, that all these solutions, far from placing the proofs in conditions of stability, always introduce sulphur, inevitably, that agent of destruction so much dreaded by the photographer. These solutions, then, must be wholly rejected for toning: they are so now almost generally; the cautions we gave have borne their fruit, and it is very satisfactory for us to see the efforts we have made to secure the permanency of positive proofs crowned with success. We shall therefore not dwell upon the processes connected with this class of solutions; they belong to the photography of the past; moreover, since the *Mémoire* of 1855, referred to above, we have carefully watched their mode of action.

Here we confine ourselves solely to the study of the various solutions of gold, and sometimes of platinum, employed by photographers for toning. Do they satisfy the two conditions required by our definition? Do they give, and under what conditions do they give, agreeable hues? Do they introduce into the substance of the proof any compound of a nature calculated to effect an alteration? These are the two questions which must be solved, the one by the practical photographer, the other by the analytical chemist. But before describing the solution, we must endeavour to render an account of the chemical nature of the reactions which take place during toning; in a word, describe the theory of this operation; certain that in the course of this inquiry the remaining facts will present themselves and furnish us with the elements necessary to resolve the two questions proposed.

2. *Theory of toning*.—As well as chemical theory will permit us to foresee, it is by a simple operation of substitution that toning is effected; a portion of gold is deposited, a portion of silver is dissolved, and gives place to the gold; it is the same when toning takes place by means of solutions of platinum. The result is the same whatever the conditions; whether the paper be sized or not, the toning bath acid, neutral or alkaline; whether the toning takes place before fixing or after, gold is always deposited. Doubtless, remarkable differences present themselves according to circumstances, but we have not taken these differences into account for a moment, but confining ourselves to the general fact, we say, in toning a portion of the silver disappears, and is replaced by gold or platinum.

The proportion of metal thus deposited is very regular in quantity; it varies a little, it is true, with the intensity of the proof, the time of toning, &c., but in the ordinary conditions of photographic operations, it maintains a proportion between the fourth and the fifth of the quantity of silver in the proof. This is shown by the following example arising from the analysis of photographic proofs toned with chloride of gold.

Silver	2.28 grains
Gold	0.43 "

It is the same with proofs toned with platinum, as shown by the following numbers:—

Silver	0.96 grains
Platinum	0.25 "

In the first case the proportion is about one-fifth, in the second it a little exceeds one-fourth.

This proportion, which we have very often verified, varies a little, as we have before stated, from different causes, and especially, as might be foreseen, with the time during which the proof remains in the toning bath. Still, the increase in the weight of gold never surpasses certain limits, the substitution of the gold for the silver must never be complete: in a word, the silver must never entirely disappear from the proof. The contrary opinion has been announced lately by Dr. Schnauss, of Jéna, who assumes the possibility of an absolute substitution, but this opinion rests upon an error in analysis: we have had occasion to dispute it, and must now recur to it. Let us first relate the experiments upon which our conviction is based; in order to free the operation from all accessory circumstances, these experiments were made upon paper simply salted, and the toning

took place only after complete fixing; so that in the event of a certain portion of silver remaining on the proof after toning, it could not be attributed either to the presence of albumen, or to non-impressed insoluble compounds, but to some other cause. The papers, well fixed and washed, were introduced into the gold toning bath, and kept there for *thirty hours*, frequently renewing the bath, in the fear that if it became weakened, the toning would not proceed so freely. These papers fixed anew, to remove the chloride of silver engendered during the substitution of the gold, and well washed, gave the following numbers upon analysis:—

Silver	0.38
Gold	1.14

These numbers are doubtless very different from those obtained under ordinary conditions; the gold is in much larger quantity, but still it has not replaced all the silver. Upon similar proofs not toned, analysis gave 1.80: the toned proof again contained 0.38, and we thus found ourselves led to conclude that the gold cannot remove all the silver, and that there always remains upon the toned proof about one-fourth or one-fifth of what it contained before toning.

In a theoretical point of view, there is nothing surprising in this result. In fact, the proof must be considered before being placed in the toning bath, as a simple plate of silver immersed in the bath, it presents two surfaces to it, the one in the pulp of the paper, the other on the surface of the paper; those two surfaces are gilded, and the silver is dissolved; but when the layer of gold has acquired a certain thickness, the middle part, placed between the two surfaces, cannot be reached, and remains undissolved. This result, which takes place every time a metallic plate is immersed in a gold solution, as for example, in wet gilding, is known to all chemists.

And it is solely from not having taken this fact into account that Dr. Schnauss has fallen into error. In his experiments, the proof prepared and toned under the same conditions as ours, was leicaterated, and the ashes submitted to the action of nitric acid, which, according to Dr. Schuauus *ought* to have dissolved the silver, if the proof had contained any. There lies the error; a proof thus prepared may contain silver which the nitric acid will be powerless to dissolve. In fact, during the gilding a true alloy is formed between the surface of the gold and the surface of the metal which serves as a support to it; in the present case, this is an alloy of silver and gold; the proportion of gold is very considerable ($\frac{2}{3}$) and chemists know very well that alloys of this nature are not sensibly attackable by nitric acid. It is precisely to avoid falling into this error, that, in the numerous quantitative experiments we propose to describe, we have always taken care to appeal to inquantation, that is to say, bring the alloy into such conditions that the gold was not in greater quantity than a fourth of the silver.

After having thus established that the theory of toning rests upon a partial substitution of gold for silver, we have considered under what conditions this substitution takes place, and if it occurs in proportions required by the laws of equivalents. Here commences the great perplexity of the question, for the toning processes based upon the employment of salts of gold are numerous (we put aside the tonings with platinum, very rarely employed, and which act like the tonings with gold), and it is evident that the presence of the reagents added to the gold must considerably modify the results, and consequently influence the tone, intensity, and various other qualities of the proof.

(To be continued.)

ON THE BEHAVIOUR OF CHLORIDE, BROMIDE, AND IODIDE OF SILVER IN THE LIGHT, AND ON THE THEORY OF PHOTOGRAPHY.*

BY HERMANN VOGEL.†

I now pass to iodide of silver. I have already stated that this undergoes no visible alteration in the light. The question is whether any chemical change takes place, such as occurs with the chloride and bromide.

I first endeavoured to ascertain whether any iodine was set free. For this purpose I dropped freshly prepared thin starch

paste upon iodide of silver which had been long exposed to the light in a glass tube. No reaction took place. Nor could any evolution of iodine be observed during the exposure of iodide of silver covered with starch-paste to the most intense sunlight, and no free iodine could be detected with sulphuret of carbon. I repeated this test with starch-paste, containing iodide of potassium, which, according to Schöubein, is much more sensitive than pure starch-paste, but even with this no trace of free iodine could be detected.

From these experiments made under the most various conditions, I cannot but conclude that no iodine is set free by the action of light upon iodide of silver. Consequently, if iodide of silver undergoes a decomposition, this can only consist in the formation of *free silver*, or of a *subiodide*, and of a *superiodide*.

The formation of free silver can only be ascertained in this case by dissolving the undecomposed iodide of silver with hyposulphite of soda; by this means I obtained no residue of free silver. Free silver cannot be detected here by means of nitric acid, as iodide of silver is decomposed by that acid, both when boiled and when allowed to stand for a long time in the cold. The formation of free silver is, moreover, improbable, inasmuch as it must have betrayed itself by rendering the surface of a grey colour.

There consequently remains only the second supposition—that of the formation of a subiodide and of a superiodide. The production of the latter is, however, highly improbable. Even chlorine and bromine, although endowed with far stronger affinities, have but a slight tendency to form superchlorides and superbromides; still less shall we find this tendency in iodine. We know, for example, perchlorides of iron and copper, but no periodides of iron and copper in a free state. In experiments on the formation of such bodies protiodides alone are produced and iodine is set free.

Hence I cannot make up my mind to admit the formation of a superiodide of silver, and the less, as it is extremely improbable that, if it should exist, it could resist the action of iodide of potassium. But if no superiodide is formed and no iodine is set free, the formation of a subiodide or of metallic silver is likewise impossible. From these experiments and the views here developed, I am consequently led to the conclusion that *when iodide of silver is exposed to the light no chemical decomposition takes place*.

I have hitherto been describing the behaviour of haloid salts of silver which had been prepared by the agency of an *excess* of the precipitant (HCl, KBr, KI). *Somewhat different results are obtained by the employment of haloid salts precipitated by an excess of the silver salt*.

By this means the chloride, bromide, and iodide of silver are thrown down as caseous precipitates which are easily filtered and washed, whilst with an excess of iodide and bromide of potassium, the two latter, as already stated, form an extremely fine powder, which in part passes through the filter.

I prepared the above-mentioned three haloid salts by lamp-light, and washed them until the washing water no longer gave any silver reaction. I will indicate the haloid salts thus prepared as Ag Cl β , Ag Br β , and Ag I β , and those above described as Ag Cl α , Ag Br α , and Ag I α . Ag Cl β and Ag Br β do not differ from Ag Cl α and Ag Br α in external appearance, but Ag I β is decidedly a deeper yellow colour than Ag I α . The difference in the behaviour of the salts on exposure to light was more characteristic.

Ag Cl α is decomposed under the action of light more slowly than Ag Br α (*vide supra*); Ag Cl β , on the contrary, is decomposed in the light more rapidly than Ag Br β ; for if two tubes with Ag Cl β and Ag Br β and iodized starch-paper be placed simultaneously in the sunlight, the paper is always seen to acquire colour sooner in the tube with chloride than in that with bromide.

I ascribe the more rapid decomposition of Ag Br α , as compared with that of Ag Br β , to the finer division of the former, which is strikingly manifest even during its preparation.

As regards coloration, Ag Cl α and Ag Cl β , as also Ag Br α and Ag Br β , behave *exactly alike*. But the case is different with Ag I β ; for whilst Ag I α does not exhibit the least change of colour by exposure to light, Ag I β becomes decidedly grey, with a greenish tinge.

I now tried whether iodine is set free during the exposure of Ag I β . The experiments were made in the same way as those

* Continued from p. 532.

† Poggendorff's "Annalen."

* The original says Ag Br and Ag Cl β , but this is probably a misprint

above described with AgIa, and repeated many times, but I could not detect the least trace of periodine. In two experiments I noticed that after the exposure of the iodide in glass tubes for six hours, the iodized starch-paper enclosed with it was rendered slightly blue. But upon closer examination I found that the iodide employed contained a very small quantity of chloride of silver. From these experiments it is evident that neither AgIβ nor AgIα undergoes any decomposition by exposure to light.

ON THE COLLECTION OF RESIDUES OF SILVER AND GOLD IN PHOTOGRAPHIC ATELIERS.

BY DR. D. VAN MONCKHOVEN.

CHEMICAL analysis proves, that of every 100 grains of nitrate of silver employed in a photographic atelier, nearly 90 are found in the residues. We may therefore understand how important it is to collect as much as possible of these residues of silver, &c., and especially to collect them in such manner as to render their conversion into metallic silver easy.

Gold, now so generally employed for *toning* paper positives, is collected with much more difficulty from the residues, and its extraction is much less easy than that of silver; still, by operating in a suitable manner, we can recover a third of the gold found in old *toning* baths.

The *silver residues* are found:—

1st. In filters having served for silver baths; the bibulous papers employed for cleansing the frames of the camera; spoilt positives, &c. All these papers should be preserved in a large wooden box, and *when they are perfectly dry*, burnt to obtain their ashes. The best method consists in employing a well-cleaned iron pot, set over a clear fire, and placing a lighted candle beside it. The papers being opened, and lighted at the candle, are left to burn out in the pot until they leave a *white* ash, and *not black*, as would be the case if the papers were burnt *en masse*.

The ashes must be preserved in a bottle kept specially for the purpose.

2nd. *Old hyposulphites*. Throw them into a wooden cask,* which may be placed in a corner of a yard, or other open space. When it is full, throw in a solution of sulphide of potassium (liver of sulphur). Care must be taken to preserve this salt in glass stoppered bottles, else it gradually changes into hyposulphide of potassa, which does not precipitate the salts of silver. It is best to operate upon old hyposulphites only when a large quantity has accumulated.

It is necessary to be careful and not add an excess of sulphide of potassium. To avoid this risk, the following mode of testing may be followed. When the deposit in the cask has separated after the sulphide has been added, take a portion of the supernatant liquid, put it into a test glass, and add a few drops of the solution of the sulphide; it will then be easy to recognise if all the silver (and gold) have been precipitated. If the addition of a few drops of the sulphide produces no cloudiness, make a reverse test; take another sample of the liquid, and add a few drops of solution of silver to it; if a precipitate now takes place, it shows that too much of sulphide has been added, a fresh quantity of the fixing bath must then be added, and left to settle. These tests are necessary, for if sufficient sulphide has not been added, a portion of silver in the washings will not be precipitated, while, if too much be added, a portion of the precipitate is re-dissolved in the excess of sulphide, which causes a loss. But the latter defect is not so mischievous as the former.

A muddy precipitate is thus formed at the bottom of the cask which solidifies of itself in the course of a few days. Open the tap placed near the bottom of the cask, and allow the clear liquid to flow out. Add more old hyposulphite, and after repeating the operations several times, clean out the cask and throw the muddy precipitate upon a filter, and leave it to drain for several weeks.

Turn out the filter and put the black precipitate into porcelain dishes or upon plates of glass, and leave it to dry *completely* in a warm room.

3rd. Procure a cistern (mark it "*chloride of silver*") capable of holding forty or fifty gallons, larger at bottom than at top, and furnished, at four inches from the bottom, with a glass or wooden tap (not brass).

Pour into this cistern:—

A. Old silver baths.

B. The solutions which have served for washing the proofs before toning.

C. The metallic silver mud arising from the development of collodion negatives.*

D. The rinsings in washing dishes, &c., which have contained silver baths.

E. In a word, all the waters contain silver, except those containing cyanide or hyposulphite.

F. The *kaolin* used for clearing silver baths, which always retains a portion of silver. Collect it in a glass vessel, and add to it its volume of nitric acid mixed with water; let the mixture stand some hours, and then decant the liquid into the chloride of silver cistern.

When the cistern is nearly full, add some commercial muriatic acid (but no chloride of sodium, which dissolves a certain quantity of chloride of silver), stir it, an abundant white precipitate is formed, which is left to settle. Take a little of the clear supernatant liquid in a glass, and add a few drops of muriatic acid. If a precipitate is formed, it shows that sufficient muriatic acid has not been added to the cistern. Then add more acid, until, after being well stirred with a stick, and allowed to settle, a fresh quantity of acid added to the liquid produces no precipitate.

Leaving the whole quiet during a night, next day open the tap and allow the clear liquid to flow off. The silver deposit will be found at the bottom of the cistern. The operations of collecting the silver washings and precipitating by muriate may be repeated indefinitely.

When a convenient time arrives to extract the silver from the residues, throw what has been precipitated to the bottom of the cistern upon a filter, which may also be employed for the residues produced by precipitating old hyposulphites by sulphide of potassium, provided it has previously been cleaned. Leave the matter to drain for several days, then *dry it completely*, placing it in a warm room, either in plates or flat porcelain dishes.

It is absolutely necessary to completely dry all the residues before extracting the silver.

The chloride of silver, if it be pure and white, will yield 75 per cent. of its weight of silver; but if it is not completely dried, or if it contains foreign matters, it yields much less. Old papers, burned to a light grey ash, yield, on an average, 50 per cent. of silver.

The sulphides give less, because they often contain an excess of sulphur produced by the decomposition of the hyposulphite, or of the sulphide of potassium employed in their preparation.

Gold is extracted from *toning* baths in the following manner:—Throw into the bath—which most frequently is thick with a black powder of gold, slowly precipitated—some commercial muriatic acid, until the bath becomes of a decided yellow colour.

Take a filtered iron solution, formed of one part of sulphate of iron, dissolved in twenty parts of water, and pour it into the gold bath, to reduce it. The gold is precipitated immediately. Allow it to settle, decant the greater part of the liquid, which is thrown away, and collect the precipitate upon a paper filter placed in a funnel, shaking the dish and pouring the contents, precipitate and liquid, upon the filter.

Leave the filter to dry, cork it up in a bottle, and keep it to be reduced to the state of melted gold.—*Bulletin Belge de la Photographie.*

* This cask must be larger at the bottom than at the top, so that the precipitates may not adhere to the sides. At four inches from the bottom, pierce a hole, and insert a brass tap.

* Developing should be carried on over a gutta-percha trough communicating with the chloride of silver solution by means of a caoutchouc tube.

ON PHOTOGRAPHY IN INDIA.

BY W. H. WARNER.*

It is with a feeling of diffidence I come before you this evening to discuss the difficulties and trials which beset the path of the photographer (whether he be professional or not) in a far-off land—a land about which, what little is known photographically, has only lately been brought home to us by a few of those ardent amateurs who have been determined, notwithstanding all trials and troubles, to succeed—a land that teems with beautiful temples, constant and ever-varying foliage, and with people and animals that are interesting in themselves.

Having lately been occupied in printing large numbers of these very subjects for a celebrated amateur, they have led me to make many observations, which, without seeing the negatives themselves, I should never have had the opportunity of doing. In looking over these negatives, I observe in particular that great caution has been used in the opposing of that arch-enemy to the photographers of all countries—dust. I notice, secondly, that nearly every picture has been taken with what we in England would term "a long exposure;" in some instances I should imagine the exposure had been prolonged for fully three minutes. I observe, also, in some subjects, extreme detail, while in others of a similar character there is hardly any, although both have evidently received the same treatment as to manipulation. In nearly every case the negative has more or less suffered from what appears to be bad varnish: but which I have been assured was not so, it being the best Sohnée that could be procured. Lastly, that evil, which in Europe is bad enough, but in India is a million times worse—I mean heat—which dries up the plate, rendering it more and more insensitive every moment, and also communicates to the operator a lassitude which almost wholly unfits him for the duties of the day. These are some of the pleasures of photography in the East; pleasures, or rather vexations, which have bothered wiser heads than ours to overcome; and yet, looking at them fairly and steadily, I do not see but what they might be not only conquered, but actually made use of in the production of subjects. Let us, therefore, this evening discuss how these difficulties may be overcome.

What constitute the principal trials? *Dust* for one, I think; *heat* for the other. With the former, pinholes, comets, spots, and markings of all kinds appear, and mar the beauty of the picture. With the other insensitiveness, fringe-like markings, opaque spots, and reticulation of the film on drying, to say nothing of the minor evils of cameras splitting and letting the light through, glasses breaking, &c., &c., through the use of unseasoned materials. In looking more closely into the second item, viz., heat, we find that the exposure of the plate is considerably influenced thereby: dry heat tending to insensibility; damp heat to extreme—nay, excessive—sensitiveness. In India nearly all the clothes of the natives, and very many of the buildings, are white. These, with a glaring sun, in which the blue ray has little force, are very difficult to be properly rendered.

Now, as we cannot alter the heat and the light, let us see how we may obtain and keep for a lengthened period a sensitive surface which shall portray through a good lens with a small diaphragm every detail in the whitest possible dress or building, and how we may obviate and do away with the *dust* thus making photography a pleasure instead of a toil. The same remarks will apply equally to England in the taking of interiors and other subjects requiring long exposure.

In the sliding body of the camera, nearest to the plate, have inserted three thin strips of metal or wood stained black; this will form the bottom of the body into a tray. Have the same attached in a similar manner round the other

two sides and top. Then place in these trays a small piece of *spongio pilene*, dyed black for use, having dipped the *spongio* in water, and wrung it out until nearly dry. (In this stage it must be used when the sun has but little power; when very hot, use this almost wet.) Next, insert the same in the camera, and proceed to work as usual. You will observe that the *pilene* has one surface quite impervious to water; this is a non-conductor, which does not communicate its heat to the dampness of the other side, and, therefore, the inside of this portion of the camera remains perfectly damp without fogging the inner surface of the lens by a deposit of dew thereon.* It also forms an attraction to any particles of dust, be they small or large, and there they remain without the possibility of flying up on to the plate. Thus much for this, the *mechanical* portion of the subject. Having had a camera lately constructed upon this principle for a gentleman in the army, a pupil of mine, now *en route* for India, the makers, Messrs. Murray and Heath, will have much pleasure, I am sure, in showing those who may wish it a model of a camera constructed on the same plan.

Light, or the actinic force by which all pictures taken by the rays of the sun are formed, is, in my opinion, from what I have read and seen, but imperfectly understood in India, and, indeed, in many parts of our own country. Take, for instance, the usual run of large landscape pictures throughout England. Every operator has a different idea upon the subject of exposure: one considers it should be short, the other long; yet at the particular minute at which the picture was taken, there was *only one* proper time of exposure. How rarely do we see a picture perfect in every part; I am speaking generally. There are some gentlemen whose pictures always resemble the motto which accompanies Horniman's tea. Such are Wilson, England, Blanchard, Thompson, Bedford, Sedgfield, Breeze, Rejlander, and Robinson; but all these talented men will tell us that they, too, each and all, find a difficulty in deciding, at some time or another, what exposure to give certain pictures. They, too, have their failures along with others.

If, therefore, this is the state of things here, how much more difficult is it for the amateur to arrive at the proper exposure in a country like India? The climate, from all accounts, affects the human constitution more from its dryness than its dampness. In the wet season people are always healthier and better; photographic operations are generally successful then.—[*Vide* letter of Mr. S. Bourne, in *The British Journal*.]—Take, for example, a day in the hot season (4 a.m.), warm and light, cool air, thermometer at 75°. This is the pleasantest part of the day; the only time when photographs can be well got. Two hours later we have it 96°, and over 100°, till it reaches its maximum, during which period all out-door operations are at an end, except by the natives, whose craniums are well wrapped in white, to preserve them from the effects of the sun. As the day declines, a heavy dew succeeds, to be out in which is certain death. In the wet season, however, work may be done all day, in comfort and ease.

This summer, in England, we had, for a short time, a sample of what an Indian day is. I had letters from numerous gentlemen inland stating that they had found the same non-actinism of the light as myself, whilst others, at the sea-side, found no difference at all.

Then, again, in rainy weather—not foggy weather—the air is always clear; and though plates, when exposed, lose some portion of their charm from the lack of sunshine, yet there is a total absence of dust, spots, &c., &c., and the comfort of working is much increased. In India, the midday light is nearly all from the red and yellow ray, very little blue. Professional printers state that a negative may be exposed in the pressure frame until quite scorched, and yet be scarcely printed, while in the early morn and the wet season, a few

* Read at a meeting of the South London Photographic Society, Nov. 12th, 1863.

* The camera for India should be covered with canvas painted or stained black inside, and pure grey or white outside.

minutes suffice. The remark so aptly made by Mr. T. R. Williams this summer, that it was *the dryness of the atmosphere*, and *not* the light, was perfectly correct; and were we to carefully observe the various atmospheric changes, we should see that cold and damp induce to sensitiveness and rapidity of operation, while heat and dryness are the opposite. Dry and cold is good because it is clear and bright. Take, for instance, an October morning, or an April day—sun and showers. Contrast these with a hot sultry July and August day. Compare the results, and you will find in the one case points of light sparkling like diamonds here and there all over the plate, while the half-tone and the shadows have brilliancy and detail. In the other, although fine, there is a want—a something not easily definable, yet at the same time there.

I was much struck the other day with the force and truth of these observations. Being professionally engaged in illustrating a celebrated waterfall in South Wales, and having fallen in with what all would term “abominable weather”—damp and rainy to a degree—I found I could, with a compound lens well stopped down, get most exquisite effects, while on those days when we had the most brilliant sunshine and heat, the results were poor and meagre.

One day that I spent at the Abbey of Strata Florida, it rained (without fog), slightly all day, yet I got most exquisite pictures with moderate exposure. Another that I spent at Pontrhydyreos, brilliant and lovely though the scene looked to the eye, yet in the camera, the results were poor. I also compared the pictures of Bedford, taken in the winter with, I think, a single lens (Ross's), with those of Pumphry, taken in the summer with the same or a similar lens. In the former, there was detail and brilliancy; in the other, there was the lazy, snowy appearance so often got when the light and atmosphere appear to dance before one. Much, I admit, depends upon the manipulation in both cases. The proper management of the developer, its strength, &c., all help to form the whole; but without a correct appreciation of the quality, the intensity, and the quantity of the light—unless the correct, or nearly correct, exposure be given—the results will not be satisfactory. In India I am not in favour of using chemicals in extra quantities. A thirty-five grain bath made of pure recrystallized silver, such as supplied by Johnson and Matthey, of Hatton Garden, made slightly acid with acetic acid; a collodion formed of equal parts of Perry's bromo-iodized and Ponting's plain iodized mixed; developer of the strength of five, eight, to ten grains of iron to the ounce, according to the state of the atmosphere; the plate intensified by Blanchard's excellent formulæ (if necessary), *no pyro*, the Indian operator will be able to compete with his English brother, and work both with ease and comfort. Let the camera be fitted in the manner I have before stated, and the difficulties of Indian operations in photography will be materially lessened.

In conclusion, although I advocate dampness as opposed to dryness, still I do not entirely approve of the quantity of wet—“heavy wet” I may say—experienced since I have been in Wales.

Where the falls they roar, the streams they pour,
Forming cascades ne'er heard of before;
Where 'mid steaming vapours with thund'ring shocks,
The Welsh Niagara wears its rocks.

EXPERIMENT—PINHOLES.

A FEW days ago we took two stereoscopic negatives consecutively of the same object, with a pair of Harrison's globe lenses (of whose qualities we shall speak hereafter). The time of exposure in either case was ten seconds, and they were both developed with the iron solution and acetic acid, and were both equally vigorous and free from apertures after fixing. The first we intensified as follows:—The plate, whilst still moist, was flowed with a dilute solution of iodine in iodide of potassium, until the film assumed a slightly yellowish grey appearance all over; it was then well washed and flowed with two drachms of a solution of pyrogallie

acid, acetic acid, water, and nitrate of silver, in the following proportions;—

Pyrogallie acid	1½ grain
Acetic acid	1 drachm
Water	7 drachms

Nitrate of silver at the rate of 4 drops to each drachm.

After a while, as usual, the sky and other light parts become sufficiently intense for a negative. The plate was finally washed, dried, and varnished. It is free in a great measure from any decided imperfection.

The second plate we developed, fixed, and treated with a solution of iodine in iodide of potassium, in every respect the same as the first; and then, after washing, allowed the plate to dry. We afterwards varnished the edges and put it aside to dry. After a couple of days we immersed the plate in water, in order to moisten the film, and then treated it with the same intensifying solution as the first. As soon as the sky and other light parts were sufficiently vigorous, we washed the negative and examined it. It was speckled all over, and full of pinholes as well as holes of larger calibre. The negative is quite useless; it has got the measles or some other nameless dermatous eruption.

With the iodine treatment alone, the negative appeared almost intense enough. The colour at first was a yellowish grey, but it became bluish black in a day or two when exposed to the sun and diffused light, almost as black and intense as the first negative.

Photographers, draw your own conclusions; we are not prepared to draw any legitimate ones ourselves yet; we merely register the facts.—*Humphrey's Journal*

Hints to Operators.

A GOLD TONING PROCESS.

A CORRESPONDENT from whom we have at times received some exquisitely toned prints, in answer to our inquiry as to his toning process, sends us the following, accompanied by some stereographs, which are at once excellent in selection and manipulation. They will find a place at once in our selected gems. The tone is just that which we admire for landscape purposes. However valuable black tones may be occasionally in portraiture, we may remark here, that we think it is a great mistake to aim at black tones for landscape prints. The sentiment of many a lovely sunny landscape is spoiled by having black tones. These are a very beautiful, rich, deep brown, without the slightest approximation to redness or foxyness; but the deepest tone of warm sepia, a thoroughly sunny tone. As all the prints we have received are uniform in tone, we presume that with careful manipulation similar results may follow in other hands. It will be seen the carbonate of soda is used for neutralizing, and we presume the solution will not keep, but that it will be best mixed a short time before using.

Toning process.—In the first place dissolve half sovereign in

Nitric acid	1 drachm.
Hydrochloric acid	5 drachms.
Water	6 „

place this in a wide mouthed bottle with the coin on the hob, by the fire; it will dissolve in about 12 hours; when dissolved add sufficient water to make it up to 16 ounces, and label it *Solution Chloride of Gold*.

In another bottle make a saturated solution of carbonate of soda.

In another bottle, make a solution of common salt, 3 ounces to the pint.

Float your paper on a bottle of nitrate of silver, 90 grains to the ounce of water, or rather five ounces of water and one ounce of alcohol to the ounce of silver. I find that the alcohol keeps the solution colourless without the use of

kaolin. Print rather deep, and when your day's printing is complete, place the prints in a large dish of soft water and let them soak for half an hour, change the water once or twice, I need not tell you to save the water. While this is going on prepare your toning bath according to the number of prints; practice alone will determine how much, but, as an approximation, for about one gross stereoscopic take of

Solution chloride of gold	... 2 ounces
" of carbonate of soda	... 3 "
" of common salt	... 15 "

I may add that the cold weather is set in, I find it advisable to warm this solution, though in the summer, it tones so fast you can hardly manage it.

After well draining the water from the prints, place them in the toning bath one or two at a time, and when of the desired colour, place them in a dish of running water; when they are all toned, commence the fixing by placing them in a saturated solution of hyposulphite of soda for a quarter of an hour, then well wash.

CELESTIAL PHOTOGRAPHY.

At the October meeting of the New York Photographic Society, a paper was read, by Dr. Henry Draper, upon his arrangements for the photographic delineation of celestial objects. Dr. Draper said:—

"In the autumn of 1858, I determined to make the largest reflecting telescope in America. Its construction, together with the various improvements successively added, has occupied me, up to the present time, more than five years. The instrument, which is nearly sixteen inches in aperture, and thirteen feet in focal length, was intended to be devoted to celestial photography, and consequently contains many novelties especially fitting it for that purpose. A description of it was read at the Oxford meeting of the British Association, in 1860. It has since then been completed, and has now the largest silver reflector of any instrument in the world, except that in the Imperial Observatory at Paris. The Smithsonian Institute is preparing to publish shortly a full account of it, which will contain the entire detail of construction. The reflecting telescope is greatly superior to the achromatic for photographic purposes. In my instrument a movement of the sensitive plate, one-hundredth of an inch on either side of the true focus, visibly injures the image. In the great achromatic at Cambridge, on the contrary, the position of the plate may be varied over an inch without any noticeable change. The difference is simply that, while by reflection the visual and chemical rays both converge to the same focus, by refraction they do not. A sensitive plate, put where the eye sees the image sharply, produces a fine result in a reflecting telescope, but does not in an achromatic. Besides this, more light is reflected by a large silver mirror than an achromatic of equal size can transmit. At first I used speculum metal for my mirrors, but abandoned it at Sir John Herschel's suggestion in favour of silvered glass, the reflecting power of the latter being 93 per cent., while that of the former is at the best but 75 per cent. A large achromatic only transmits about 75 per cent. The glass mirror, too, weighs not more than one-eighth as much as the metal one—the one weighing 16 lbs., the other 128 lbs. It is also greatly more permanent, for if the silver coating which covers the glass concave should by chance be injured, it can be dissolved off easily with nitric acid, and the mirror resilvered in an afternoon, and this may be repeated indefinitely. A person making such a silvered glass reflector is content to take the greatest pains to produce a glass concave of the utmost perfection, for once that is obtained, it need never be lost. The thin sheet of silver deposited upon it, only 1-200000th of an inch thick, copies with the last degree of accuracy the glass beneath, and does not modify the figure of the surface, but only increases the reflecting power from two or three per cent. up to more than 90. This silver coating is transparent,

and shows bright objects, such as the sun, of a light blue tint, by transmitted light. The instrument has been in working order for eighteen months, but a large part of the time has been unused, because of my absence with the 12th Regiment, in Virginia, and on account of the duties of the Natural Science Professorship, in the University. With my father's (Professor J. W. Draper) assistance, I have, however, taken some very fine photographs during the past summer. Changes have been made in the photographic processes commonly used, in order to fit the pictures for bearing high magnifying powers. I have negatives which can be enlarged by a power of 32, without showing granulation or other effects to an offensive degree. The photograph which I show you to night is nearly two feet in diameter, and is magnified to 210 times the size of the moon as seen by the naked eye. It is the largest that has ever been made. I have now another, however, still larger in my observatory—nearly three feet in diameter—made under a power of 320. It represents the moon on a scale of 70 miles to the inch. In the picture before you attention should be directed particularly to the Appennine range, Copernicus (with his reflecting streams), the great groove from Tycho, the numerous craters, with an internal cone, the irregularities visible in the bottom of the Mare Imbrium. But it is useless to particularise; there is an almost inexhaustible supply of objects for study and admiration. The Society will see that, although celestial photography may be, as yet, only in its infancy, it is rapidly advancing. Every day is giving origin to improvements, and, even now, the limit of size in these pictures is rather owing to the great expense and difficulty of working such enormous plates, than to any intrinsic defect of the images to be copied."

Correspondence.

FOREIGN SCIENCE.

[FROM OUR SPECIAL CORRESPONDENT.]

Paris, November 12th, 1863.

SOME distracted penny-a-liner, at a loss for a new subject upon which to torture his pen, has revived the old hoax of the means of detecting a murderer by examining the retina of the victim, upon which, it is said, a picture of the murderer would be found impressed, and that if this were photographed immediately, it might, could, and would furnish a means of detecting the guilty. Perhaps it would, were it true, but it is one of those things we may be permitted to doubt, in the absence of ocular demonstration. In fact, I would not believe it were I to see it, having previously pronounced it impossible; and I think those who know anything of the cause of vision, and of photography also, will hold the same view as I do. However, a Dr. Sandford, of Boston, Massachusetts, has ventured to proclaim to the world that he has obtained a decisive proof of this remarkable *fact*. A certain Mr. Beardsley was murdered; thereupon, Dr. Sandford, in the interests of justice, and to the honour of photography, set to work. He began by dilating the pupil of the victim's eye, by means of a solution of belladonna; then the pupil, having been photographed, the picture was examined under the microscope, and exhibited the murderer—face, figure, clothes, and even the stones with which the murder was perpetrated.

Surely the doctor's imagination helped him a little, or he is inclined to amuse himself with the wonderful gullibility of the Boston *savants*. Our opinion remains the same—that it is all *mi-hi*.

The new session of the Photographic Society of Marseilles commenced with a meeting of the members on the 8th ulto. The chair was taken by M. Vidal, who remarked that the Photographic Society of Marseilles has taken an initiative and progress, which prove how strong the power of association is, which, without speaking of the resources and greater

influences, is seen in the emulation it excites, and in the clearness and development of the ideas which give rise to discussion.

During the present year, this Society, faithful to the programme it laid down, has actively pursued the study of dry collodion. Important works have been undertaken in this direction, and success has happily crowned the efforts of many members of the Society. The sensibility of dry collodion, however, leaves much to be desired, since the various processes communicated require from eight to ten times more exposure than wet collodion.

The constancy of the tannin process is not a sufficient advantage, we must contrive to give to this process a sensibility equal to that of wet collodion, and then photography will have made a great step in advance. There are three problems to which this Society has been devoted for the past two years, none of which have yet been resolved, notwithstanding the efforts and labours of a great many intelligent disciples of our art. These problems are—The permanence of positive proofs, the perfection of enlarged portraits, and instantaneous dry collodion; neither of these questions is yet satisfactorily solved in such manner as to render them legitimately the resource of practical photography, and yet the future of the heliographic art depends upon their complete solution.

In connection with this subject, M. Vidal entered into some technical details, and enumerated the successful attempts made by several members of the Society, foremost among whom are MM. Teissière and Jacquemet, whose labours are so well known in the scientific world. M. Jacquemet exhibited a caoutchouc dish entirely made with his own hands, and intended for washing dry collodion plates in.

It is well known to those who practise the tannin process, that before putting the tannin on to a sensitized plate, the latter must be submitted to as complete a washing as possible; we arrive at this with certainty by means of this dish and a stream of water, the jets of which are so arranged as to establish a current above and below between each plate.

It is a matter of regret and disappointment that photography does not occupy a more important position in the Exhibition of the Application of the Fine Arts to Manufactures, now open in the Champs Elysées. The fault is neither in photography nor photographers, but arises simply from the fact that the photographic exhibition is not a new one, but that which formed a portion of the *Salon*.

Among the most interesting specimens now first exhibited are some pages of a magnificent album in which M. Lafon has reproduced the whole of the *Campana* collection in the *Musée Napoleon III.* It consists of time-worn marbles, bronzes, enamels, terra-cottas, &c., with all the rust of antiquity upon them. The photographer's task was an immensely difficult one; but his success is complete. Two editions of the work will be issued; one costly, consisting of photographs, the other cheaper, by M. Poitevin's photolithographic process.

Exhibitors of manufactures have made good use of photography in giving representations of their inventions under a most satisfactory aspect to their customers; the draughtsman might mislead by exaggeration or imaginary perfections, photography being truth itself, and unimpeachable, is unhesitatingly accepted by the purchaser as a *fair* sample.

Photographic Notes and Queries.

PYROGALLIC ACID AND FORMIC ACID PRESERVATIVE.

DEAR SIR,—Having, the other day, a plate in my bath for which I had no further use, I took it out, washed it, then poured once on and off some old decomposed pyro and formic developer, and set aside to drain and dry.

After the lapse of some eight or ten days, I thought I would just try it for a transparency. So, giving it a second's exposure to day-light, and then a slight washing, I poured over some old

citric acid and iron developer, to which I added a few drops of nitrate of silver solution. To my surpriso, I got a much clearer picture than I had hitherto been able to obtain by the tannic formulae.

I regret not having much time for experimenting in an art at once beautiful and tantalizing; so, present gratis, if not forestalled, this hint for a new dry process to your thousand readers.—Yours, truly,

CORNISH CROUCH.

[Pyrogallie acid has been before suggested, and tried as a preservative, with more or less of success.—Ed.]

ELECTRIC LIGHT FOR PHOTOGRAPHY.

SIR,—In part reply to Mr. Busch's letter in your last, knowing a little of photography and a little about electricity, I once did print on a dry plate of some kind, so long since, that I forget what kind of plate. I had a very small induction coil, 2½ in. diameter, and 7 in. long, excited by three nitric acid iron cells, 3 in. diameter and 6 high. I used a condenser and attached the two ends of coil to the inner and outer coatings of Leyden jar, and then had a Lane's discharger, and adjusted the *nobs* to just striking distance; then by the flame between these *nobs*, I printed a stereoscopic plate. I moved it rapidly in front of the flame, and a few inches off, for about half a minute—the flame was about ½ inch. long.—I am Sir, yours truly,

W.N.B.

P.S. I should like to know where *cheap* apparatus are to be had.

OIL FOR TROUBLED WATER.

SIR,—It was said of old that the public functionary whom every one applauded could have very seldom done his duty.

Now, Sir, I hope I am not conceited, but it *is* gratifying to know that when recently playing the part of a public functionary in your pages it was not every one who applauded *me*.

But then, again, it *isn't* gratifying, because, my love of approbation is an extensive bump, and I am therefore sorry to find that at least two worthy and respectable married couples have been loudly indulging in very severe comments upon me as the writer of "A Dozen Hints to Portraitists," stating that the productions sold by the agent I described were their productions, and that consequently I therein dared to find fault with their work.

Permit me to assure both these manufacturers through your pages, that I neither know where the agent came from, nor who had produced the work he was engaged in vending.—Yours, &c.,

R. A. S.

Talk in the Studio.

NEW MEMBERS OF THE PHOTOGRAPHIC SOCIETY.—The following list of new members of the Photographic Society, duly elected at the last meeting, were accidentally omitted from the report in our last:—Messrs. T. Annan, Glasgow; T. B. Hutton, Guernsey; A. Harman, Peckham; H. Squire, King William Street; R. Faulmert, Woodlands, Lancashire; A. Wyatt, Fareham; A. Brothers, Manchester; V. Blanchard, Camden Cottages; W. Atkinson, Builth; F. Cooke, Tunbridge; John Eastham, Manchester; T. Lampray, Paternoster Row; Samuel Fry, Gracechurch Street; Athol Mayhew, Hart Street, W. C.; and Mrs. Spottiswoode, Phillimore Gardens.

COLOURED PHOTOGRAPHS.—We lately mentioned a dispute which had arisen between a M. Ricco, of Modena, and Colonel Baratti, director of the *Camera Oscura*, a photographic journal published at Milan, about priority of invention, both claiming to have found a method of producing photographs in the natural colours of the originals. We now find, from a number of the *Camera Oscura*, that the invention is far from being so important as was at first supposed; still it is worth describing as a decided improvement. Suppose it be required to colour the photograph of a man in a black coat, whose hair and beard are fair, and whose figure is projected on a white foreground, slightly shaded off. The process of the inventors is as follows:—The photograph taken by daylight lies in a basin full of water; it is dark, and the subsequent operations are performed by candle-light. Two solutions are at hand, one A, consisting of 1 gramme of chloride of gold and 10 of acetate of soda, dissolved in 1,000 grammes of water; the other B, consisting of 20 grammes of hyposulphate of soda, dissolved in

100 grammes of water. There are besides two more basins with water and a quire of blotting-paper. The photograph is taken out of the water, and put between the leaves of blotting-paper; it is then laid flat on a pane of glass, and the whole surface, except the face and hands, receives, with a water-colour brush, a coating of solution A. By this means the parts subjected to the action of the gold soon change their tints into black. The photograph is then put into clean water again, and left there for a few minutes, during which the operator prepares a second photograph if required. The former one being taken out, is put into solution B, where it stays for a few minutes, and is then washed and rinsed as usual. Now, as the time of immersion will influence the depth of colour, by successive immersions an orange-coloured cravat will be obtained in one minute, a coffee-coloured greatcoat, in five, violet-coloured trousers in ten, and a black coat in thirty minutes, while the hyposulphate of soda, or solution B, gives colour to the flesh and hair. Hence, certain colours, though not quite the natural ones, may be obtained, which is a decided step in advance.—*Galignani.*

PHOTOGRAPHIC PIRACY.—The London Stereoscopic and Photographic Company have just obtained another injunction with costs, which were heavy, against a vendor of piracies of their Exhibition photographs. A Mr. E. Watson, of Tottenham Court Road, was found to be selling largely pirated copies of the stereoscopic slides, printed as paper transparencies, at twopence each. These it appeared were imported from abroad, and were probably the production of Mr. Ceileur, who was before successfully proceeded against by the company for pirating similar works, and whose wholesale business in piracy has recently issued in bankruptcy and sudden disappearance.

To Correspondents.

**** PRESENTATION PRINT.**—We have pleasure in announcing to our readers that we have just completed arrangements for presenting to our subscribers, at an early date, a copy of Kenilworth Banqueting Hall, by the photo-electric engraving process of Mr. Duncan Dallas, from a negative by Mr. Francis Bedford. The print will be on tinted paper, the size of a page of the NEWS, from a plate untouched by the hands of the engraver. It is unquestionably the finest specimen of heliographic engraving which has ever been issued.

QUANTUM finds, in a recent formula, the phrase "6 grains of chloride of gold and sodium, containing 3 grains of chloride of gold?" he does not understand its meaning, and consults his friends. One says it means one thing, and another the contrary; but they all "agree that it is a careless and stupid way of describing the matter." He is equally at a loss as to the meaning of a "saturated solution" of anything. There is no great culpability attaching to "Quantum," or his friends, for being ignorant of the meaning of such phrases, but they are culpable when, being ignorant, they presume to characterize what they do not understand as careless or stupid. The salt to which Mr. Cooper referred is a regular article of commerce—a double salt of gold and sodium, two grains of which contain one grain of chloride of gold, so, prepared for the purpose of more readily securing an article without free acid. The term saturated solution suggests its own meaning. It is a solution in which as much of anything is dissolved as the liquid can hold in solution. For instance, bichloride of mercury is soluble in 16 parts of cold water; one ounce in 16 ounces of water will make a saturated solution, and if you add more it will remain undissolved. Bicarbonate of soda forms a saturated solution by adding 1 ounce to 10 ounces of water; chloride of sodium, by adding 1 ounce to 2½ of water, and so on; as much as can be dissolved forming, in all cases, a saturated solution.

C. BRYSON.—We prefer No. 2, and all we hear confirms this opinion.
STEPPING STONES.—The only danger you incur by using the droppings from the steam pipe in a factory is the possible contamination with organic matter, which sunning the bath will get rid of. You cannot very well colour a picture on albumenized paper, without slightly dulling the surface. The addition of dilute albumen to the colours has been recommended. We believe the tints or dyes sold for applying to photographs do not dull the surface.

BEAY.—The stains are probably caused by want of care in manipulating. The announcements of pictures registered, which appear in our pages, only refer to those sent to be registered by our publisher. It does not include any others.

JOHN MILTON.—A photograph must be registered before any copies are sold; but it does not matter how long it has been produced. You must fill up a descriptive form, and send it, with a copy of the picture, and Is. 3d. in stamps, to our publisher, who will then undertake the rest for you.

R. M.—It is probable that a salt of copper remained. It is not, however, we think, so important as some conceive to get rid of copper, or other metal, in preparing the chloride for your own use. It will do no harm if present, some believe that it will be even beneficial. 2. If you have not facilities for driving off the acids perfectly, you may keep the chloride in solution and neutralize when you require for use by means of chalk.

A. H.—A good copy of your print might, with great propriety, be sent to the Exhibition, and the stereos also; the cattle are especially interesting.

The entrance fee to the Photographic Society is one guinea, and the subscription a guinea a year. If you join now you will only pay subscription for the half year. We shall have pleasure in proposing you.

H. T. H. V.—Some plan of adjusting for focus at the back of the camera is decidedly desirable, and the travelling-screw answers very well. You may have the screw added to your camera without infringing any patent. 2. Instantaneous photography consists in securing a good negative by an exposure as short as can possibly be given, uncovering and covering the lens by the most rapid motion which can be applied. If your chemicals are in sufficiently good condition, your lens sufficiently rapid, and your light sufficiently bright, you may take portraits instantaneously. 3. The price of a glass-house may vary from £20 to a few hundred pounds; it entirely depends on size, style, &c. We do not know of one for sale. 4. The print enclosed is good for a beginner. 5. Uniformity of result can be secured by sufficient skill; as a beginner, you will fail at times; but skill will come with practice and perseverance. 6. For collodion the first you mention is excellent, and, so far as we know, the paper you are using is very good.

Y. Z.—If you had sent us a specimen of the defect to which you refer, we could better have understood its nature. It may arise from the drainings of the plate accumulating at the head, or from the developer not flowing evenly, or from the collodion being over-iodized, or some other cause, of which, without seeing the defect, we cannot speak.

S. JONES.—You may use either oxide of silver freshly precipitated or carbonate of soda for neutralizing the silver bath. If you use the former, take the freshly precipitated oxide (to make which we have often before described) and add to the solution with frequent agitation; after a few hours, filter. If you use carbonate of soda, take a 20-grain solution and drop a few drops at a time into the bath, agitating well between each addition. Each addition will cause a little turbidity at first, which will clear up again; continue adding until a slight permanent precipitate or turbidity is formed. It will now be quite neutral. Let it stand a few hours in the sun, and filter. 2. Throw down the silver in washing waters as a chloride, by the addition of common salt. 3. A tub may, with propriety, be used for containing it. 4. Burn paper clippings to ashes, and then put the ashes into the crucible with the flux. 5. If large quantities of touting solution be used, it may repay the trouble to obtain the gold from the effete solutions. Add protosulphate of iron, which will throw down the gold in a metallic state. Wash the precipitate well, and dissolve by means of *aqua regia*. 6. For mounting properly, glass shapes, a glass plate for cutting on, a sharp knife, fresh starch paste and a brush are required.

A. NOTICE.—In our opinion, A. decidedly. It is possible that you may meet with a genuine one, second-hand, from either of the dealers you name; whether you will save much or not, we cannot tell. The names you mention in your last list are many of them dealers, not makers, and the makers are not equal to the first mentioned.

ENQUIRER.—You will find the best information on the lime light in several articles on pages 13, 40, 74, and 136, in the fifth volume of the PHOTOGRAPHIC NEWS.

DEAFIA.—Your card is somewhat hard from over-intensifying. 2. After neutralizing an old bath it is desirable to sun it, and then add nitric acid very carefully, until it works clean. When it gets out of order again repeat the process.

T. COLLINS.—We prefer the first you name as possessing the qualities you require in the highest degree. We use it frequently. The last you name is good, but not so good as the first. We have no further decision regarding the Exchange Club at present.

PETER GRIFFITHS.—The metallic-looking stains are probably caused by hypo coming into contact with the prints before fixing, probably from handling with unclean fingers. There is no way to remove such stains, and the only way to avoid them is to use extreme care and cleanliness in working.

G. WILTON.—Your print is a little over-toned, but not quite sufficiently printed. Deep printing is required to secure deep tints. You require double the proportion of acetate of soda. The negative is pretty good.

CRAIOTS.—The Daguerreotype process was patented in this country in the year 1839, by Mr. Bevy, a patent agent for M. Daguerre. 2. In the same year it was ostensibly given to the world by the French Government, who pensioned Daguerre, in consideration of publishing his process. The patent was secured in this country, whilst the negotiations were pending with the French Government. This country was thus excluded from the gift, by what looks very like an underhand job. 3. Mr. Fox Talbot first announced his photographic discoveries to the Royal Society in 1839, and patented the process, with improvements, in 1841. 4. Some specimens of collodion positives were exhibited in the Exhibition of 1851. We have in our possession a collodion negative of the interior of the building.

A. GRANT.—The card pictures are a little hard; that of the lady is, however, a very pleasing photograph. Several Correspondents in our next.

Photographs Registered during the Past Week.

- MR. PETER MAITLAND LAWS**, 38, Blackett Street, Newcastle-on-Tyne, Two Photographs of Father Alford.
MR. EDWIN GREETHAM, 129, High Street, Portsmouth, Four Photographs of Mr. W. Brown, Proprietor of the South of England Music Hall, Southampton.
MESSRS. W. AND D. DOWNEY, 9, Eldon Square, Newcastle, Photograph of Right Hon. Sir F. T. Baring, Bart., M.P., Photograph of Rev. T. N. Rutherford.
MR. GEORGE TEAGLE, 90, Oxford Street, Swansea, Photograph of the Rev. Charles Cooke.
MR. ALFRED ROSS PRING, New Street, Mold, Photograph of the Rev. William Warlow Harry.
MR. JOHN BEATTIE, Strathearn House, Clifton, Three Photographs of the Right Rev. the Lord Bishop of Gloucester and Bristol. Four Photographs of Captain Speke, Discoverer of the Sources of the Nile.
MR. A. BROTHERS, 14, St. Ann's Square, Manchester, Photograph—Meeting of Civil Engineers at Manchester.

THE PHOTOGRAPHIC NEWS.

Vol. VII, No. 272. — November 20, 1863.

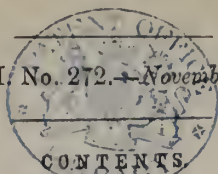

	PAGE		PAGE
Card Portraiture.....	553	Proceedings of Societies—South London Photographic Society...	561
Scientific Gossip.....	554	Correspondence—Scenic Backgrounds in Tints.....	562
New Light for Enlarging Photographs. By M. Mc. A. Gaudin...	555	Photographic Notes and Queries—Toning and Mounting—Elec-	
The Employment of Photogenic Powders for Printing Vignettes, &c. By M. Mc. A. Gaudin.....	556	tric Light for Photography.....	563
Proportion of Salt in Albumenized Paper. By Alfred Harman...	556	Talk in the Studio.....	563
The Recently Discovered Early Photographs.....	557	To Correspondents.....	564
		Photographs Registered during the past Week.....	564

CARD PORTRAITURE.

WE recently visited the establishment of Mr. T. R. Williams, to examine some improvements in his arrangements for the production of card portraits, which we propose to describe for the benefit our readers. We should remark at the outset, that amongst the cards we inspected were the most perfect examples of excellence in all photographic qualities we have ever met with. The vignette whole-plate heads of Mr. Williams have long been a standing illustration amongst photographers of all the most desirable qualities of portraiture. His recent card pictures have been in all respects of excellence the counterparts of the vignettes. Brilliant as it is possible for photographs to be, yet unsurpassingly delicate, soft, and full of tender gradations; wonderfully round and full of relief, and admirably defined at all points of the picture. The members of the Photographic Society, to whom Mr. Williams recently presented each a copy of their president's portrait, will at once recognize the union of many of the qualities of which we have spoken, in the charming picture they received; but it was by no means an isolated example, as many of the specimens to which we refer are still more perfect photographs. In mentioning the *recent* cards of Mr. Williams, we do not intend disparagement to his former pictures of this class; but, merely to emphasise the fact, that the recent productions are best, and that their excellence is due to various specific improvements.

The first improvement to which we shall refer is in the method of lighting. Mr. Williams' glass room is constructed, as it is with many metropolitan and other portraitists, in accordance rather with the necessities of the position, than with the design, which might, under other circumstances, be chosen. The light is derived chiefly from the top. The room is nearly square in shape, measuring about thirty feet each way. It has the usual ridge roof, which is dark or opaque on the slope at one side of the ridge, and glass at the other. The ridge is not, however, quite in the middle, the slope from the ridge to the eaves at one side extending further than the other, this side having the glass and facing the west. Adjoining the sky-light, there is also here a foot or two of glass in the front, but not reaching the ground by about eight feet.

The skylight is furnished with double sets of blinds, one set being blue and the other white. The blind rollers are placed at the highest part of the roof, so that the blinds may, by partial rolling up, be made to admit the light to any extent and at any angle which the position of the skylight permits. These blinds are in three divisions, any of which may be completely down whilst the rest are withdrawn. The background is placed underneath the opaque roof fronting the skylight.

If one of these blinds be withdrawn whilst the two others are down, it will be seen that a sitter placed under the latter will be illumined with what is practically a high side-light,

If two be withdrawn and one down, the sitter under the latter will be illumined with a high side-light and top-light. If all the blinds be withdrawn, or partially withdrawn, the sitter will be illumined with a front and top light. The varieties of lighting afforded by these arrangements were found to answer admirably for the production of large portraits. By keeping one or more of the blinds quite down, with the sitter under it, whilst the other blind was quite withdrawn, sufficient side-light effect was secured, and by turning the head the flattening effect of front light was avoided, whilst the amount of diffused light gave texture and softness, and carried detail into the shadows.

This method of lighting, which answered so well for large head was not found so successful in card pictures. The exigencies of position in portraying full-length figures often compelled the use of front light, and in attempting to overcome the flatness, a tendency to hardness resulted which was difficult to avoid. The presence of diffused light, which in large heads gave softness, in cards had a tendency to destroy relief and produce weakness. By the skilful management of chemical conditions it was possible to avoid allowing these tendencies to prevail in any exaggerated degree, but still the pictures so produced did not possess the qualities which had given such a pre-eminence to the vignettes.

By an entire re-arrangement of the position of various objects, however, it was found possible to secure the conditions of lighting which would give to card portraits the qualities which distinguished the others, and produce the charming pictures to which we have referred. This is effected by placing the sitter and camera at opposite corners of the room, thus altogether changing the relation of the light to the sitter. The background, &c., instead of being parallel with the front light, is placed cross-corner wise, and the camera at the opposite diagonal corner. The high front-light is thus converted into a high side-light, and more complete power in obtaining a direct light, from an angle largely under control, is secured. Instead of relieving the shadows by diffused light, it is largely dispensed with, and reflected lights are produced by a screen covered with blue calico placed at a suitable angle. The effect of this direct light is to give bold and well relieved contours, whilst there is sufficient of reflected light, and what the late Mr. Lacy used to call glancing light, to give texture and softness. The direct light has another advantage; it causes the figure to cast a soft shadow on the background, which is of immense value in giving relief and preventing the inlaid effect sometimes seen when the figure stands against a spotless, plain background unrelieved by light or shadow. If those of our readers who have glass rooms constructed in a manner similar to that of Mr. Williams will try the experiment of working in the direction to which we have just referred, they will readily perceive the increased control they obtain over the direction and concentration of the light.

In order to work from either corner of the room, as the state of the light or the desired position of the sitter may render necessary, there is a background in each corner. In

connection with these there are some other improvements. The backgrounds are not moveable, but fixed in their position. At each end of each screen is another movable screen placed at right angles, one at the end next the light for regulating the light and shadow on the background, the other, covered with blue, for regulating, by reflections, the shadow on the face. To avoid showing a head-rest, which sometimes appears in a very unsightly manner behind standing male figures, Mr. Williams has had a very clever contrivance constructed. Behind the background a base, carrying a firm pillar, is screwed to the ground. At the top of the pillar, which is about two feet or thirty inches high, is a V groove in which slides a stout wedge-shaped bar, which can, by means of a clamping screw, be fixed at any point. This bar projects through a small aperture in the background, and carries another pillar in front of the screen, to which is attached the head-rest, which possesses universal joints, permitting it to be moved in any direction. It also carries a rest for the back, which is of infinite value in supporting standing figures, giving the utmost ease in pose, and affording almost absolute security against the sitter moving. It will readily be seen that by this contrivance the sitter has the best possible aid to perfect and motionless ease and tranquillity, without any awkward head-rest being seen, or unmeaning mass of drapery being thrown about the feet to hide it. The sitter must, of course, be placed somewhere near the right position in relation to the rest, to begin with, but the universal joints admit of sufficient adjustment to prevent the stiffness which would ensue if the sitter had to accommodate himself to a fixed and rigid rest. As will readily be seen, all the parts of the rest must be firmly made and fitted to secure sufficient firmness and rigidity of support.

The height and position of the camera, which are of more importance than is thought by some, receive careful consideration. They must vary of course with circumstances; but for standing figures of medium height the following relations are preserved. The floor being level, and no platform used, the distance from the floor to the centre of the lens is about forty-six or forty-eight inches, which brings the lens about opposite the chest of the model. This, for giving equality of definition to the whole figure, is rather too high; but if the lens were placed lower, an unnatural and inartistic view of the face would be obtained, the under portion of the features being rendered as though the observer were looking upwards at them, a most displeasing effect. To compensate, in definition, for placing the lens a little above the centre of the model, the rising front of the camera is raised about one-fourth of an inch, and the camera very slightly tilted, so that the central pencils are chiefly used in defining the figure; the camera being of course made so that under ordinary circumstances the plate and lens should occupy their usual central position. The camera is only very slightly tilted, just sufficiently to gain an advantage without any perceptible disturbance of perspective resulting.

This arrangement with the card lens used—Dallmeyer's No. 2 B—gives excellent definition to all parts of the figure with open aperture, and the most perfect definition that can be desired with a central stop of $2\frac{1}{4}$ inches diameter, which is the smallest aperture Mr. Williams ever uses. The focus is not necessarily obtained on the eye, but frequently on some prominent object on the chest: this being sharp, the lens has sufficient depth to give not only the face, but the hands, feet, accessories, and all parts of the picture in satisfactory definition. A focussing eye-piece is always used to obtain certainty in focussing. With the stop, the exposure is in summer from two to five seconds, and with open aperture nearly instantaneous. In winter the longest exposures given are from fifteen to twenty seconds. If negatives are not obtained with this exposure, the light is considered so bad that sitters are declined.

Mr. Williams does not use scenic backgrounds; the screens are painted, in flattening a warm grey of medium tint.

A variety of carved oak accessories, such as tables, cabinets, bookcases, flower stands, &c., are occasionally introduced; and sometimes a curtain; the camera, &c., are surrounded by a small dark room, to prevent as much as possible diffused light from entering and spoiling the brilliancy of the picture. One lens is used, and a back with three repeats, taking three portraits in succession on a whole plate, a size which leaves ample margin for working with comfort.

Bromo-iodized collodion, by various makers, is used. A thirty-grain silver bath, as nearly neutral as possible. An iron developer containing about fifteen grains of the proto-sulphate and fifteen minims of acetic acid to an ounce of water. The exposure is always so full that the development is rapid, and the plate is washed before the slightest trace of deposit has had time to form on the deepest shadows, the negatives always presenting some points of bare glass. They are fixed in hyposulphite of soda, and then, after thoroughly washing, are intensified with the usual solution of pyrogallie acid, acetic acid, and a few drops of fresh nitrate solution. The negatives thus obtained, although exceedingly brilliant, print very rapidly in the shade, sun printing being generally avoided.

A moderately strong printing-bath, strength depending on the paper used. For very thin negatives, a paper containing a very small proportion of salt to the albumen. A toning bath of chloride of gold and acetate of soda made always a week in advance, but never used twice. A fixing bath of hyposulphite of soda, one part in six of water, never used twice. Washing for four hours in rapid changes of water. These, with the utmost care and delicacy used at every stage, produce the charming pictures we have described, which, as examples of exquisitely perfect photography, we believe, are not surpassed in the world.

Scientific Gossip.

SILICON, A NEW COMPOUND SENSITIVE TO LIGHT—LEUKON.

The photographic action of light upon all matter was some time ago a favourite subject of discussion and experiment. The researches of Herschel, Hunt, and others went far to prove that the chemical change which light was capable of inducing upon mineral and vegetable bodies was not confined to a few substances only, but extended generally to a vast number of substances in each class. Probably chemists would find this subtle agent much more generally active than they have hitherto suspected it to be, were it not that, from the fact of their almost always working with apparatus and reagents bathed in a sea of light, the changes or modifications produced by this force are unnoticed by being merged into and confounded with those obtained by ordinary chemical force. If it is desired to ascertain the action of moisture upon any compound, it would clearly be inadmissible to perform all the operations in an atmosphere saturated with aqueous vapour, and it is equally impossible to notice the chemical action of light on a body when both it and the reagents which act upon it are constantly kept in the light. Some few notable instances, it is true, have been observed by experimentalists, and precautions are consequently always taken to prevent photogenic change; thus in preparing silver salts of organic acids, care is taken to avoid exposing them to the action of light, and in some few other instances, similar precautions are recommended; it is also known that some dyes are only to be obtained in perfection on a bright sunny day; but putting these instances on one side, we may say that the already known photographically sensitive bodies are very small and not one-tenth of the number which might be discovered if proper steps were taken to isolate the action of light from other interfering causes.

The addition of a new member to a class of bodies is always of interest, but the discovery of a new and very sensitive photographic body is of especial value, more particularly, if entirely new ground is opened out by it, and

the stranger comes before us as the representative of a new series of elementary bodies hitherto unsuspected of the slightest tendency to photographic change. If we had had to hazard a prediction as to the body whence the next photographically sensitive compound would be derived certainly the last substance which would have suggested itself would have been common flint, or silica. Until the last few years, silicium, the basis of this, was about the most uninteresting substance in chemistry, but now, through the researches of Wöhler, it bids fair to rival any of the other elements in the number and interest of its compounds. This chemist has recently discovered several new compounds of silicium which are of the highest importance. The starting point of them all is a curious, metallic-looking alloy of silicium and calcium, which is easily prepared by fusing together silicium, chloride of calcium, and sodium, with certain precautions. The silicide of calcium is then obtained in a button of a lead grey colour and perfect metallic lustre. In water this slowly disintegrates, forming a mass of lustrous scales like graphite, some impurities being extracted from it by this solvent. Strong nitric acid does not attack the silicide, and this acid affords the best means of obtaining it free from impurities. The most remarkable action of the silicide of calcium is its behaviour with hydrochloric acid, by which it is changed into an orange-yellow substance, a brisk evolution of hydrogen taking place. This yellow body is called by the discoverer *silicon*, an inappropriate name, we may state *en passant*, as the metallic basis of silica, *silicium*, is often called silicon, and is generally known under that name in chemical books. Silicon is prepared in the following way:—The silicide of calcium, purified as above, is treated with concentrated hydrochloric acid in a vessel which must be placed in cold water to prevent the heating of the mixture. An evolution of hydrogen soon takes place, and the silicide is gradually transformed into silicon. The mixture must be often stirred to bring the powder entangled in the froth in contact with the acid, and then left for some hours in a dark place until the evolution of gas has ceased. It is then diluted with six or eight times its volume of water, the silicon filtered off, carefully protected from the light, well washed, then pressed between bibulous paper, and finally dried in a vacuum over sulphuric acid, the bell glass being covered with a black cloth. Silicon is of a bright orange-yellow colour. It is composed of transparent yellow laminae. It is insoluble in water, alcohol, and other solvents; when heated it becomes of a dark orange yellow. On applying a stronger heat it takes fire with a faint deflagration and some sparkling, leaving a residue of silicic acid.

The behaviour of silicon when exposed to the light is very remarkable. In the dark, even when moist, it remains quite unchanged. In diffused light it becomes paler; but in direct sunlight it, in a short time, becomes perfectly white, and hydrogen is given off. When placed under water in sunlight, hydrogen begins to be evolved immediately, and continues like a fermentation until the silicon has become quite white. The purer the substance the more quickly does the change take place, and several grammes are transformed in a few hours. If, however, it has not been perfectly protected from the light in the course of preparation, it is much longer before the whole is altered in sunlight. The formula of silicon is not accurately settled; but it contains silicium, hydrogen, and oxygen, and is supposed to resemble an organic body, in which silicium replaces the carbon. Professor Wöhler, indeed, suggests that it may, perhaps, be the type of an entire series of similar bodies, and it would then open the prospect of a special chemistry of silicium as of carbon. When we remember Dr. Hofmann's celebrated definition of organic chemistry—"a history of the migrations of carbon"—and think what a vast subject that now is—a science of itself almost too vast for one mind to grapple with—we may well feel interested at the prospect opened out to us, of a new science having silicium for its basis.

The behaviour of silicon with metallic salts is curious. In the presence of an alkali, even of dilute ammonia, it is gradually changed into silicic acid, with evolution of hydrogen. When mixed with an alkali, whilst this decomposition is going forward, it acts as a powerful reducing agent on the salts of the heavy metals. Solutions of copper or silver salts soon become black, and gold solutions brown. From solutions of chloride of palladium and osmic acid, on the addition of an alkali, it immediately precipitates a black powder. A solution of lead in caustic soda is precipitated in the metallic state as a grey mass. The reducing agent in all these cases is evidently the hydrogen in a nascent condition.

When silicon is thoroughly acted on by light, it is converted into a white body, to which the name Leukon has been given. The composition of this is also a matter of doubt, but it is a body of a somewhat similar composition to silicon, and in the presence of alkalis it behaves in the same way with some metallic salts. The mode of formation of leukon from silicon, under the influence of light, is also obscure; the most probable theory is that 4 atoms of water are decomposed, 4 of oxygen and 1 of hydrogen uniting to the silicon, and the other 3 of hydrogen being set free. According to this view, silicon is $\text{Si}_3 \text{H}_4 \text{O}_6$, and leukon is $\text{Si}_3 \text{H}_5 \text{O}_{10}$.

NEW LIGHT FOR ENLARGED PHOTOGRAPHS.

BY M. MC A. GAUDIN.

ENLARGING positives has made but very little progress since its *début*: this is the result of persisting in attempts to operate upon chloride of silver, which absolutely requires continuous clear solar light during several hours, while in operating with *iodide* of silver, and developing the picture with gallic acid, the process requires a light of one-fifth the power.

The obstacle principally alleged against the employment of iodide of silver is very puerile—that generally it does not give such fine tones as chloride of silver: but we do not see why the toning with salts of gold should not cause this inferiority to disappear, if sufficient attention be paid to this feature.

For my own part, I, who have studied for a very long time the process of development by means of gallic acid when I produce positives on collodion and upon paper with artificial light, I do not find that this charge of inferiority can be sustained, especially when operating by continuation upon *chloride* of silver.

It is a fact, which I believe to be general, that the insoluble compounds of silver sensitive to light become absolutely insensible whenever they are accompanied by their solvent. This has been shown in the case of iodide of silver when accompanied by iodide of potassium: not only is it then insensible to light, but, if it has already been exposed to light, a new luminous action in presence of iodide of potassium, will destroy the first impression, however intense it may have been. We can, therefore, imbue a cotton tissue, several yards in length, with iodide of silver insensible to light, prepared in full daylight with a slight addition of albumen, coagulated by passing a hot iron while the tissue is moist, then it may be washed in plenty of water, also in daylight, to free it almost entirely from the iodide of potassium, and then, to make use of it, it will be sufficient to sensitize it and expose it while moist to the action of the enlarging apparatus.

The same tissue, prepared with chloride of silver, and put to digest with a very weak solution of pure cyanide of potassium, should, for the same reason, be insensible to the action of light: and if this chloride of silver is somewhat slower to be impressed than iodide of silver, there is, on the other hand, the advantage of allowing the light to penetrate its entire thickness, on account of its transparency, as I have proved, and not give a merely superficial picture, like iodide of silver.

By proceeding in this manner, we should require for enlarging neither solar nor electric light, nor many hours' exposure, a small lime light and a few minutes' exposure will be sufficient.

The lime light is that which has served for some time for steamboat signal lights. It consists of a simple reservoir of oxygen gas, which is discharged under a pressure of 8 inches of water. This gas, by passing through a reservoir of ether, becomes saturated with it, and no longer explosive. It burns in the open air exactly like the flame of alcohol; but upon causing this portion of gas saturated with ether to arrive side by side with pure oxygen gas, but by means of a double cock, which regulates the portion of each to produce the maximum of brilliancy from the illuminating lime; the result is like a little sun, which, being fixed in the focus of a parabolic reflector, 8 inches in diameter, sends a bundle of parallel rays a distance of 10 yards, and which, collected by the enlarging apparatus, will, in one or two minutes, produce an impression on the continuous paper of chloride of silver, capable of assuming a fine bistre hue, by means of gallic acid and acetic, and the gold toning does the rest.

This apparatus always ready for use costs about £7, consisting of

Oxygen gasometer of 40 gallons	... £	2	0
Ether apparatus with lime jet	... £	3	10
Parabolic reflector	... £	0	15
Caoutchouc tubes	... £	0	15

£7 0

The light costs per minute for ether and oxygen gas about one penny halfpenny.—*La Lumière*

Upon this M. Saint Edme remarks, in *Cosmos*—"This experiment of M. Gaudin's is very interesting, as it is a means of producing the Drummond light with oxygen alone; but in a practical point of view, especially in photography, we do not perceive the advantage of substituting etherized oxygen for coal gas which is now so accessible. The luminous intensity and chemical nature of the rays remain the same, the etherized oxygen only supplying as combustible the carbonated hydrogens existing in coal gas. As to economy, it is evidently on the side of the Drummond light, as etherized oxygen in equal volume costs, at a minimum, from four to five francs the cubic *mètre*, and coal gas only a few centimes. The method proposed by M. Gaudin is applicable only to such cases as where coal gas is not attainable, or pure hydrogen cannot be prepared.

THE EMPLOYMENT OF PHOTOGENIC POWDERS FOR PRINTING VIGNETTES AND ENLARGED POSITIVES.

BY M. MO. A. GAUDIN.

The photogenic compounds of silver most employed in photography—the iodide, chloride, and bromide, when prepared by chemical precipitation, form a paste, which solidifies still more upon drying, and cannot be spread in a thin coating, by rubbing upon paper. It is quite otherwise with these same compounds when they are prepared by the action of the metalloids in vapour upon silver leaf. With time, this excessively divided silver completely loses its metallic lustre, and becomes transformed into transparent pellicles which can be spread upon paper with a tuft of cotton, in an homogeneous layer as thick or as thin as may be desired.

It is very easy to impregnate a sheet of paper of medium size, with iodide of silver, &c., by chemical precipitation, and that is the method generally pursued. But if we proceed to fix these photogenic compounds upon a limited portion of a sheet or upon a very large sheet of paper or tissue, the ordinary process loses its advantage.

Iodide of silver, for this new purpose, is prepared by placing a piece of silver leaf in a dish, the bottom of which is covered with iodine in scales covered with a piece of paper.

The silver fixed in position, the box is closed, and the reduction is allowed to go on until all trace of silver has disappeared, which takes place at the expiration of twenty-four hours, more or less, according to the temperature.

To produce chloride of silver by the same means, hypochlorite of lime in powder must be substituted for the iodine; in this case the reaction is much slower, and in order for it to take place, the piece of paper must be replaced by muslin gauze, and the dish must not be completely covered, because the action of the chloride takes place only by the intervention of the carbonic acid in the adjacent air.

As to the bromide, it is prepared by suspending a light muslin bag containing silver-leaf into a wide-mouthed bottle, into which some bromine is placed, and covered with water. In this case the operation proceeds as quickly as with iodine.

When we rub a coating of these powders upon paper by candle light, we cannot distinguish the coating by its colour, the whole appears white, and the only means of knowing where the coating exists is, by raising the paper to a level with the eye; wherever the coating exists, the surface appears dull or *mat*.

This was an impediment to the general employment of these powders, but upon reflecting that the employment of iodide of potassium presented a sure and ready means of rendering the iodide of silver specially insensible to light, a very ready method presented itself of forming coatings in broad daylight, when large surfaces are required to produce enlargements on. After covering a paper or a tissue as uniformly as possible, it suffices to stop all ulterior action of light, to immerse the sheet of paper or the tissue in a solution of iodide of potassium of 1 per cent., and dry them in the daylight, and sensitize them as wanted in the operating room, with a silver bath of 2 per cent. strength, and immediately expose them to the radiation of the enlarging apparatus.

For vignettes, the iodide of silver formed in the dark will be introduced into a wide-mouthed bottle, and after having added a minimum proportion of fused nitrate of silver, finely pulverised, rub the mixture upon the sheet of paper covered with a thin card, in which a rectangular elliptical, or circular square, has been cut, which will limit at will the place and the surface of the coating upon the sheet of paper.

It now only remains to cause a jet of steam to act upon it for a few seconds, to complete the preparation and render it proper to receive the luminous radiation behind a negative, and afterwards develop the picture, with gallic acid acidulated with acetic acid, as has been described many times before.

This process will be found very expeditious, in the space of twenty minutes, twenty sheets for vignettes may be prepared.—*La Lumière*.

PROPORTION OF SALT IN ALBUMENIZED PAPER.

BY ALFRED HARMAN.*

MR. CHAIRMAN AND GENTLEMEN,—I am induced to bring the results of these experiments before you for the purpose of arriving, if possible, at something like a conclusion as to the proportion of chloride to the albumen for albumenizing paper, which gives the best results for general purposes.

I know many professional albumenizers are ignorant of photography, and therefore cannot be aware of its requirements, and the statement which has been made that a certain albumenizer puts a handful of salt to a jugful of albumen proves some investigation into the subject to be necessary.

I have observed for some years past, that paper which I knew to be very slightly salted, always gave me more brilliant prints than most albumenized paper of commerce, which I believe contains about nine or ten grains of chloride to the

* Read at a meeting of the South London Society, on Thursday, Nov. 12th.

ounce of albumen. A print showed by Mr. Hart at a meeting of this Society, printed upon simply albumenized paper without any chloride whatever, confirmed this opinion, and I resolved to make these experiments to guide me and others in their printing operations.

I know that the strength of the silver bath would influence the quality of the print, according to the amount of chloride in the paper, therefore I used one of 60 grains per ounce of water, which I think is about the strength usually used by most photographers.

Here are four prints; No. 1, floated upon albumen with three grains of chloride of ammonia per ounce added; No. 2 with six grains; No. 3 with ten grains, and No. 4 with sixteen grains.

When a low salting formula is used, we can undoubtedly employ a much weaker silver bath, and still obtain equally brilliant prints as with a high salting formula and a strong bath, thus meeting the requirements of amateurs, who, when using strong silver solutions and not saving their washings, are at a very great loss through waste, &c.

I am sure a great deal of the difference of opinion regarding the strength of the silver bath for printing arises from different persons using paper prepared with various proportions of chloride in the albumen. One photographer, who is using paper with a small proportion of chloride, obtains good prints in a weak bath, and is surprised to find others with a similar bath cannot. The reason is obvious. The silver bath should in all cases be regulated according to the amount of chloride in the paper, and manufacturers should give the proportion of salt they use, to guide photographers as to the strength requisite for their bath.

As a matter of course, paper weakly salted prints slower than a highly salted sample, and likewise I have noticed the prints have a redder hue, but I invariably find that when such is the case, the toning takes place more evenly, and the finished prints are much finer. The chloride of ammonium gives a much redder colour in the frame than chloride of sodium, and for that reason I prefer it.

Remarks on this subject must necessarily be short, but I have no doubt will lead to much interesting discussion. I therefore place it in your hands, feeling confident that many valuable suggestions will be offered, and lead to improvements in that all-important branch of photography—*Printing*.

THE RECENTLY DISCOVERED EARLY PHOTOGRAPHS.

Our readers are familiar with the facts upon which the history of the alleged photographs of the eighteenth century is based. We now give the extracts from various letters and other documents from which these facts are obtained, and from which our readers can draw their own conclusions:—

EXTRACTS FROM LETTERS FROM MR. EDWARD PRICE, OF SOHO, NEAR BIRMINGHAM.

No. 1.

November 13th, 1862.

"With respect to the old sun pictures, I beg to assure you it will afford me great happiness to let you have them, and I will send them up with all the information I can collect, together with any other relics which I fancy would be interesting in your valuable museum."

No. 2.

November 26th, 1862.

"I beg leave to apprise you that I have this day sent from hence a small parcel containing a few old portraits of celebrated men, which I think will be interesting to you. My friend who borrowed the two sun pictures is from home, and I cannot get at them; but I enclose one on paper, and one on silver. The latter, I was assured by an old man who died eight years ago, was taken by Mr. Boulton, Mr. Watt, Dr. Small, and Mr. Franklin in front of the old house at Soho. This old man was Mr. Boulton's 'Cad.' He was his assistant and helpmate in all his experiments and journeys; he also knew all the members of the Lunar Society—Dr. Black, Mr. Roebuck, Dr. Small, James Watt, Mr. Edgeworth (father of the authoress), Dr. Johnson of Lichfield, and all the whole lot.* He has told me many a time about the great gentlemen coming every full-moon night, and stopping very late.

* Names of some of the members of the Lunar Society:—Samuel Galton of Birmingham, Matthew Boulton of Soho, James Watt of Soho, Captain Keir, Mr. Edgeworth, Dr. Withering, Dr. Stokes, Dr. Priestley, Dr. Farr, Dr. Davison,

"The room they used was like a Freemasons' lodge; indeed I believe the Lunar Society was really a lodge, because, when we pulled down the old library, I found traces of a lodge! For instance, the men pulled off the paper at the end of the room for lighting the fires, and upon the plaster I found traces of the emblems of masonry: there was (east) Δ and other signs; but, of course, you not being a mason, I cannot explain more.

"This old man Townsend Mr. Buckle at the Mint knew well. The old veteran died at the age of eighty-nine years, according to his widow's account, but ninety-two, of his own.

"He told me that Mr. Beechey, afterwards Sir William Beechey painted Matthew Boulton's picture"; and when he was at Soho, Mr. Boulton explained this invention of taking sun pictures.

"Sir William then went amongst all the artists, and got up a petition or memorial to Matthew Boulton and the Lunar Society, begging them to stop, because it (the secret), if made known, would be the means of 'shutting up the painters' shops.' This was poor old Townsend's expression.

"I recollect many years ago (say twenty), Mr. Boulton, the grandson of Matthew Boulton, asking me if I could write him an article about Soho for a dictionary, and I said I could not; he then sent me a letter to Mr. Watt about the matter, and I afterwards learnt that Mr. Watt had written the article for Lewis's 'Topographical Dictionary,' under the head of Handsworth in Staffordshire. I once saw this article in Mr. Watt's own hand writing, and it referred to these sun pictures. If you can get this work of Lewis's, I think you will find something about them.

"The framed picture is, I believe, copied from a painting by some celebrated lady painter; I forget her name, but I think it was Angelica Kauffman.

"Please, my dear sir, excuse this hasty scrawl, as I am very busy moving from this dear, dear old factory where I have been twenty-eight years.

"I have many tons of books and papers to sort over. * * *"

No. 3.

1st Dec., 1862.

"I am very much behind hand with my work, having to sort out this week about five tons of old books and papers previously to hiding adieu to this venerated spot. Please excuse my hasty writing. I should very much like to have a gossip with you, but for the present must forego that pleasure.

"Rest assured I will not lose sight of the other pictures, but will send them to you the moment I get bold of them again.

"I think the tinted one on paper is the reverse from a picture by Salvator Rosa. I believe I have seen a print of it somewhere; this, you will see, is all left-handed."

No. 4.

3 Dec., 1862.

"The clipping was done ten years ago, when I had no idea of what the picture was. I admired it, and asked my carpenter to put it in a frame for me. This is the one I mentioned as being framed; but I thought afterwards it would travel safer rolled up with the others, so I took it out of its frame and sent it to you clipped just as it was.

"I fancy the plain plate was laid against the sun picture of Soho House to preserve it, because you will perceive the picture is not secured. The least touch takes off the shadow; and if I had put any packing between them, I feel sure all would have been plain by the time you received it,—in fact, a blank.

"The other photos, you saw had a number scored on the face, 7, 6, or 9; and these I still hope to get for you in a day or two.

"I don't want to tease you too much, but suppose I could give you a clue to the camera which made these pictures? I had it once! and did not know what it was for. Some thirteen years ago, I showed it to a friend of mine, and he appeared so delighted with it that I could not help giving it to him.

"When I cleared out Mr. Boulton's old library, Miss Wilkinson (aunt to the present Mr. Bolton) told me to take away 'all that rubbish,' and do what I liked with it. The Camera and these old pictures were amongst the rubbish. Little did I think what they were.

"Well, some five or six years after I had parted with the camera, my friend told me it was a most excellent instrument, and that he had taken some capital pictures with it. I then wished for it again, but it was too late. That friend was schoolmaster at Trentham, in Staffordshire, to a school supported by the good Duchess of Sutherland. Her Grace was very fond of this Mr. Powell, and used to pet him and his large family, giving him every encouragement for displaying a very ingenious mind. This Mr. Powell left her Grace's employ about six years ago, or perhaps less, and became tutor to Dr. Marks's little men."

No. 5.

13th December, 1862.

"I know you have got into deep responsibility over these sun pictures, and be assured I shall do my utmost to assist you in meeting all doubts.

"I could not possibly send you a long letter to-day.

"I merely enclose a proof-sheet from Lewis, which merely refers to pictures in oil."

Mr. Day, Sir W. Herschel, Sir Joseph Banks, Dr. Solander, Dr. Arelius, Dr. Small, Benjamin Franklin, Dr. Black, Mr. Roebuck, Dr. Johnson of Lichfield, Mr. Wedgewood.

"20, Upper Southwick Street,

Cambridge Square,

30th Oct., 1863.

"DEAR SIR,—Beechey's portrait of Matthew Boulton was exhibited at the Royal Academy in 1799, and is thus described:—

"209. Portrait of Mr. Boulton, of Soho, Staffordshire: Sir W. Beechey, R.A."

"I have found a very curious Catalogue of an Exhibition of Polygraphic Pictures, which I have sent to Dr. Diamond. The title states that they are 'copied by Chymical and Mechanical Process, the invention of Mr. Joseph Booth.' There is no date; and I have requested Dr. Diamond to show it to you. Believe me to remain,

"Very truly yours,
F. Smith, Esq."

† "The manufacture of astronomical clocks for some years was carried on at Soho; and the art of copying pictures in oil colours, called polygraphie, was also invented and pursued here under the direction of Mr. Francis

"We must find out Eginton. There are many specimens of his glass-painting in England—oué, a most splendid piece of work, at our St. Paul's Church, Birmingham; but he has been dead many years. I believe I have two pictures painted in oil by this process.
 "No one is now alive who can recollect Soho House before it was altered; at least I think not, but will inquire.
 "Excuse haste—I will write again.
 "I have found out Mr. John Powell's mother; that's something."

No. 6.

"16th December, 1862.

"There will be no necessity for advertising Mr. John Powell, as I shall have his address to-morrow from his sister, and will then write him.
 "I am quite interested in your pursuit, and begin to feel annoyed and sorry that I had not the pleasure of your acquaintance years ago. What a rich mine of relics I might have saved, which, through ignorance, are now gone out of reach!
 "I saw an auctioneer to-day, who, some years ago, was a common dealer and broker. He knew Mr. Powell; and when I inquired if he knew his address, the subject of the sun pictures came up. He reminded me that, some years ago, when I turned out all the rubbish and waste paper from the library at Soho House, he bought the old scrap paper, and amongst it, was a very curious picture which he could not make out. I did not recollect any picture being amongst the rubbish. He says that, in sorting it over, he found it, and put it on one side; since then, he has frequently brought it out, and has always become bewildered as to what it is. He says it is neither chalk, crayon, Indian ink, paint, or painting. He will bring it up for me to see; it is in two parts, he says, and from his general description, I suppose it is a brother or sister of those I sent you.
 "I have not yet found any one who could recognize Old Soho House. Samuel Vale, whom Mr. Buckle knows well, says he recollects it being altered once, but cannot tell what it was like before the alteration.
 "The publications of the Lunar Society are in the 'Philosophical Transactions.' These 'Lunatics,' as they are called, threw out such outlandish ideas, that, instead of Lunar, they were called 'Lunatics.' But, of course, the records or memos. of their private proceedings may never come to light. They put forth to the world only just what they thought proper. Their private papers, I believe, will never come to light. They were truly great men.
 "Buckle has heard from Mr. Watt (the late Mr. Watt, I mean) more about them than I can tell you.
 "Benjamin Franklin was among them at one time. Dr. Priestly was a firm member. Dr. Black came all the way from Scotland to attend these meetings on full-moon nights (as poor veteran Townsend used to call their meeting); Dr. Small, from Birmingham; Mr. Edgeworth, from Lichfield (father of Maria Edgeworth); Mr. Wedgwood (the greatest potter); Dr. Johnson; Dr. Darwin (the great botanist). I cannot think of the others; they are all gone. Mr. Galton, the Quaker, too. J. P. Muirhead, Esq., the friend and relative of the late James Watt, published lately (three or four years ago) a new edition of the 'Life of Watt.' All in this book is authentic; because I know Mr. Watt left him all his papers, books, drawings, and memoranda, &c., for the purpose of writing this life. Although I have never seen the book, I believe it refers to these sun pictures, as well as to the transactions of the Lunar Society.
 "The article for Handsworth in Lewis was, of course, written by the late J. Watt.
 "I will write again when I hear from Mr. Powell, and will not 'budge' till we have succeeded.

No. 7.

"19th December, 1862.

"I have obtained Mr. Powell's address, and have written him.
 "The broker, who has got the other pictures, expects to be paid. Of course I made very light of them, as he bought them merely as waste paper. I said he ought to return them to me as such. I asked him what he wanted for them, and he merely said he would consider of it. They should be secured by all means: they are very beautiful.
 "I shall hear from Mr. Powell in a post or two. Singular enough, he was in Birmingham on Monday, and I did not know it. His address is 22, Liverpool Road, Manchester."

Copy of Telegram from Mr. F. P. Smith to Mr. Price.

"Don't give him time to think, but get pictures at once, lowest price you can. F. P. S."

No. 8.

"22nd December, 1862.

"Do not think by my absence that I am deserting you.
 "On Saturday morning I had to meet Mr. Boulton at Malvern, and only came home late to-night, very tired. I found your telegram, and will see Mr. Shread, the auctioneer, to-morrow, and, if possible, will get the picture.
 "Mr. Powell's letter* is enclosed. He will, I know, do all he can to find the old relic camera.
 "In thinking over these pictures, I recollect old Townsend, in his gossip, telling me that they (the great men) used to have pictures on the table (not the pictures themselves, but the likeness of the pictures), and the way he tried to show me was nothing more or less than the camera obscura. He explained, 'they' were in a dark tent, and nothing but a picture on the table. By some process they secured this shadow: I have no doubt whatever about it.

Eginton, to whom it was subsequently resigned, and who became celebrated for his paintings on glass."—Lewis's Topographical Dictionary, art. HANDSWORTH.

Copy of Mr. Powell's Letter. (No. 9).

"21st December, 1862.

"Mr. Gell handed me your letter, and that of the 18th inst. is to hand.
 "It has long been a source of regret to me that, on my leaving my house at Trentham, the old and much-valued relic, the camera, vanished—whether sold by auction, or carried away by some friend while I was absent in Ireland. I have never been able to make out; however, as you are interested in its recovery, nothing would give me greater pleasure than to restore it to you. I shall, therefore, renew my inquiries, and if I can get any clue to it will not fail to let you know."

"I have written to Mr. Powell to tell him how interested I should be to get hold of my old camera again. He will do his best."

No. 10.

"23rd December, 1862.

"I have much pleasure in apprising you that I have this evening dispatched to your address two parcels; containing the pictures which I got from Mr. Shread, the auctioneer. He set a great value upon them, and I was at one time afraid he would not loose them. 'Will £10 do?' said he. '£10!' said I; 'you mean 10s.' After a good deal of bantering, I succeeded in getting them for £4 4s., and I think, under the circumstances, I did very well. They are really very beautiful. The large one in two parts is most beautiful; but where is the original painting? Some of your great men may recognize it."

No. 11.

"26th December, 1862.

"Yours to hand, with enclosure and receipt herewith for the four guineas.
 "Little did I think, when I had the pleasure of seeing you here, and showing you these old curiosities, that it would have turned out so interesting.
 "I fancy I have bothered somebody by turning up these mysterious relics. I think I have nearly exhausted my store of information on the subject; yet one thing I recollect. This old camera was about 12 inches cube, made of oak, roughly; and, and to the best of my recollection, the lens was not more than 2½ or 3 inches diameter, but there were some moveable parts in it. All this Mr. Powell will explain.
 "The whole of the rooms at Soho have long since been cleaned out, and the house left to the incumbent of the church. There is, therefore, nothing whatever (not even a scrap of paper) left there belonging to Matthew Boulton. What remains of the correspondence and books I have in my own keeping, and these must soon be dispersed for want of room. The old factory is coming down, and there are many reasons why a regular turn-out should now be made. But before I begin to destroy any papers, you shall be welcome to look at them. Bear in mind, they weigh about three tons.
 "The writing at the back of 'Flora,' was done by the broker, directly after his clearance from Soho; it was at that time a mere guess from what I had let out." * * * * *

"Depend upon it, these sun pictures were produced by a process with the help of the camera obscura. It would not, I suppose, have been possible to have got such large paper as the picture in two parts."

[Copy of a Letter from Messrs. J. Hollingsworth and Company, paper-makers, Turkey Mills, Maidstone;—

No. 12.

"29th Dec. 1862.

"In reply to your letter of the 26th, with respect to the exceedingly rough foolscap paper made by Whatman, the only information we can give you upon the subject is, that Mr. Whatman had the Mills about 100 years ago, and think that the name of Whatman was first put on the paper only, and after a few years the date of the year; and when we purchased the Mills, in 1794, the date was then in, and have continued the date of the year ever since.

"We remain, Sir, yours very faithfully,
 (Signed) "HOLLINGSWORTH and Co.

"F. P. Smith, Esq.]"

No. 13.

"30th Dec. 1862.

"The first thing is to retain Mr. Powell, to hunt up the camera, and get his account of it."
 "I shall get Powell's answer in a post or two."

[Extract from Mr. Powell's letter:—

No. 14.

"31st Dec., 1862.

"I have written to a friend at Trentham, who will, I know, make diligent search for the camera. I have such a vivid recollection of the old favourite, that if I can get it back again in a hundred pieces, I can restore it to its original condition."

No. 15.

"3rd Jan., 1863.

"In the record of the International Exhibition, part 12, page 565, reference is made to experiments made by Davy and Wedgwood* for copying paintings on glass, in 1802. The author of this article seems to have a glimmer of this great mystery."

No. 16.

"19th Jan., 1863.

"The auctioneer, Mr. Shread, has found two more beautiful old sun pictures, copies of paintings, amongst the rubbish I sold him. Had I better secure them?"

No. 17.

"5th Feb., 1863.

"Boulton and Fothergill sold pictures painted in oil by the dozens, at very low prices; and I firmly believe I have a clue to the secret, but am not yet quite ready to give you details. When I am, I will do myself the pleasure of riding up to South Kensington."

* "Wedgwood was very intimate with Boulton and Watt; and I have copies of letters to him from Boulton, but nothing about this subject."

Copies of Invoices. &c.		for S W L	
† Taken from what Masters.	4 Square Mechanical Paintings, viz.—	£	s. d.
West—One of Cephalus and Proeris.....		1	5 0
West—One of Venus and Adonis.....		1	5 0
Angelica Kauffman—One of Penelope		1	1 0
Angelica Kauffman—One of Calipso		1	1 0

No. 19.

"12th Feb. 1863.

"I saw Mr. Powell in Birmingham on Tuesday. He informs me that his friends at Trentham are doing all in their power to find the old camera; but he fears it will require a house-to-house search. He expects it will be found somewhere in the North of Staffordshire, nailed against a cottage chimney corner, and used as a salt-bar.

"He is going to send me the very first picture he took with this same old camera. It is the only picture he has, and, singular enough, the first he ever took. When I get it, I will forward it to you."

No. 22.

"23rd May, 1863.

"One thing is certain—the Soho people manufactured pictures and sold

20 Oval Pictures in form of Medallions, viz.—

Table listing 20 oval pictures in form of medallions with descriptions and prices. Items include 'Sir Joshua Reynolds—One Old Man', 'Bartalotzi—An Eastern Lady', 'Angelica Kauffman—Patience', etc.

Inside partitions case

Table with 2 rows: 'Inside partitions case' and '* Mr. Boulton's repaired.' with corresponding prices.

"SIR,—Inclosed Mr. Eginton's charge for the 24 pictures sent you this afternoon in a case mark'd in the Corner thereof, 'Paintings.' The amount being £13 7s. 6d. have credited him with in our books—you will, therefore, please credit Platino Co. for this sum, and for 2 6 more being cost of Case. The inclosed invoice is a copy from Mr. Eginton's with ye addition of the 4 paintings from Mr. Boulton's stock, which he had to repair.

I am, Sir, yr. most obed. Servt., JNO. HODGES.

"Soho, 22nd April, 1791."

"Hansworth, April 15th, 1791.

"Mr. Boulton, Bt. of Fr. Eginton for Order, S W L

Table listing items from West—Venus and Adonis, Cephalus and Procris, Angelica Kauffman—Penelope, Calipso with prices.

16 Oval Pictures in form of Medallions, viz.:

Table listing 16 oval pictures in form of medallions with descriptions and prices. Items include 'One Old Man, from Sir Joshua Reynolds', 'One Eastern Lady, from Bartalotzi', etc.

Finish from the dead colour and retouching Tragedy and Comedy Heads, and Melpomony, 15s.; and Thalia, 16s. Figures, 4 in all, 7/6

£13 7 6

"SIR,—In the above I have conform'd to the Order as near as the very low prices to which I was limited would permit some alterations I have been obliged to make on that act, particularly in the four Historical square ones which should have been according to order from 15s. to 20s. instead of which you will find one pair from West at 25s. each and one pair from Angelica at 21s. each which were the lowest Historical Pictures I could send the 16 Oval or Medallion formed Pictures are of different sizes; and altho' some of them are something higher priced than what was fixed, others are lower, so that upon the average they will be nearly the price at which they were ordered.

"I hope they will meet yr approbation and am, Sir, Your Obedt Servt, Fr. EGINTON."

them very extensively. I have many letters from purchasers, and from the entries in the books there must still be a great many of these pictures amongst the nobility and gentry in London, for they bought largely, and at such very low prices. I think Government had something to do with the suspension of this trade, because the person who held the secret was offered a pension, but Matthew Boulton objected to it in a letter to Lord Dartmouth, who was, I believe, Lord Chamberlain."

No. 23.

"28th May, 1863.

"I am in doubts whether we can prove much or anything from my old papers to establish the silver plates. But the picture-copying there is no doubt about.

"Eginton's name is erased in many places in the old books; all this is a mystery.

"Since I began this note, I have received your message. What can I do but send you my bundle of old papers? I cannot find anything about the silver plates. Boulton and Eginton, I believe, alone knew the secret, and with them it died. Eginton, I believe, came to Boulton; and they perfected some copies of pictures. A painter named Barney, and another named Wilson, had these copies to paint in oil after Eginton had transferred them from the originals. If you read the letters and papers through, I think you will be of the same opinion; and these pictures were sold by way of trade to Boulton and Pothergill's customers, the same as they were sold teapots or buttons.

"London, 10 July 1781.

"GENT,—We send you orders for some few Pictures, which must be painted in a much more masterly manner than the Pictures you sent as samples. They are all to be painted on canvas, the particulars on the other side—you will please to write us by return of post says the time they certainly can be got ready—& we likewise wish to know if the same subjects cannot be done on diff. sizes and shapes—suppose—Rinaldo preventing Armyna from stabbing herself—you give us the size of 50 lu high by 40 Inches wide Can this same picture be done 24 In high by 30 inches wide—we shall likewise want the Vale of Tivoli, some Views of Naples & a variety of Views of Italy & likewise of other diff. Views—the sizes which best please 24 In by 30 In—you'll not delay giving us the Particulars—we cannot help thinking your prices very high—and request you'll further consider and give us another list of prices—we mean the Pictures only without the frames as those we choose to have made ourselves—the wise men's offering must be of size abt 24 by 30.

"For Self & Co

"Yr. H. Ser.

"RICHD. CLARKE."

Table listing various scenes and figures with prices. Items include 'Telemachus at the Court of Sparta', 'Telemachus on his return to his mother', 'Lambica discovers herself to Tremore', etc.

The Pictures marked x we have got here.

F. P. S.

* Copy of a Letter to the Right Honourable the Earl of Dartmouth.

"MY LORD,—A few days ago I received a letter from Sir John Dalrymple, dated Dublin, May 27, in which he surprises me by saying, 'I have written to Sir Gray Cooper to have a pension of £20 per annum for Mr. Eginton; so if there is any stop, write me of it to Scotland, and I will get it set to rights, as I know nothing but inattention can stop it.'

"As I think I cannot with propriety write to Sir Gray Cooper upon that matter, having not the honour of being known to him, and as I have never mentioned the subject to him, or any person besides your Lordship, I hope, therefore, to be pardoned for thus troubling you with my sentiments and wishes.

"In the first place, I wish to have an entire stop put to the pension, because Mr. Eginton hath no claim nor expectations. I pay him by the year, and consequently he is already paid by me for all the three or four months spent in that business; and as to an overplus reward for his secrecy, I know how to do that more effectually and with more prudence than giving him annually £20, which will only serve to keep up the remembrance of that business, and therefore it is impolitical.

"Besides, it might perhaps be injurious to me, as such a pension would tend to make him more independent of me and my manufacture.

"His attachment to me, his knowing that no use hath been made of the things, the obligation he is under to me, and his own natural caution and prudence renders me firmly persuaded that the scheme will die away in his memory, or at least will never be mentioned.

"If anybody is entitled to any pecuniary reward in this business it is myself, because I have not only bestowed some time upon it, but have actually expended in money between one and two hundred pounds, as I can readily convince your Lordship when I have the honour of seeing you at Soho; and although I was induced by to believe that I was working at the request and under the authority of a noble lord (whose wisdom and virtue I revere), yet I never intended making any charge to Government of my expenses or for my trouble.

"All that I have now to request or your Lordship is that a negative be put upon the pension.

"My lord, your lordship's most dutiful, most obliged, and most faithful, humble servant,

"M. B."

Angelica "Kauffman", De Louthembourg, and others supplied the originals; but they little thought what use was going to be made of them.
 "Mr. B. says, needs no answer."
 "I now send you the other transfers on paper which I bought of Mr. Shread, the auctioneer.
 "If you require to see some of these oil copies, I know where there are two; but I should think there are many in London."

No. 25.

"9th July 1863.

"You startle me very much about the lady who is writing the Life of Josiah Wedgwood.

"In all the correspondence I have, there is no mention whatever of Wedgwood in connection with the picture manufacture, or with Matthew Boulton or Eginton on picture business, except when W. buys a picture. If she has the invoice of this camera made out in Josiah Wedgwood's name, thus:—

177	Mr. Josiah Wedgwood	
June 9	Bought of John	
One Camera with Slide, Lense, &c. complete in Oak frame	£—

"Soho, 8 Jan., '82.

"Mr. Barney, Cr.
 } Finishing a Time and Cupid £3 3 0
 } " Cupid struggle to recover his arrows 73 | 6 3 13 6
 } Hebe—finishing or retouches 0 10 6
 * Mr. Boulton's Stratonic 15 15 0
 } Wise Men's Offering 2 2 0
 } Graces Dancing 1 1 0
 } Trennor & Juibica 5 5 0
 } Null 2 Circles, Cupid Triumphant & Cupid hound to a Tree Charg'd before.
 } Return of Telemachus 7 7 0
 } Trennor 3 3 0
 } Time and Cupid 3 3 0
 "Edtd. in his Book at Soho, under the date the 31st Xr. 1781.—J. H."

I should indeed be astonished; but I believe that the camera I so unfortunately gave to Mr. John Powell was unique—the very first ever made, and made at Soho under the direction of Matthew Boulton and the members of the Lunar Society.

"This lady must be careful in not confounding the original Wedgwood

* "Mrs. Angelica Kauffman presents her compliments to Mr. Boulton, acquaints him that, according to his desire, she has done the little Picture which is to be a companion to the Penelope. It represents 'Calyppo mournful after the departure of Ulysses.'

"Mrs. Angelica flatters herself that Mr. Boulton will approve of it, as she has finished it with all possible care.

"London, " June the 12, 1778."

"Golden Square." "Mr. B. say'd he had seen her since she wrote the above."

"Sir,—I had the plaisir to receive your two letters and would have had the satisfaction to answer them immediately had j not been in the country, j also receive your draught of 15.£ 15s. and shall have the plaisir of letting you know when j have received the payment of it. Mr. Picot in my absence has delivered your Picture to Mr. Matheus else j should with plaisir have send it to you according your direction. j shall remain till the later end of 7bris at Shooters hill, and if as j hope you are pleased with your little picture and will, according to what you was pleased to tell me, want some more, j should take it as a favour if you will let me know soon and direct your letters to me at Shooters hill opposite the Bull, Kent, and j will make all speed j can to lett you have the remaining picture soonest possible. j am with regard

"Sir
 "Your most obditeent Servant
 "DE LOUTHERBOURG.

"Shooters hill, 17 August 1777."
 "— Boulton & Fothergill, Esqrs.
 "Soho, near Birmingham."

"W'hampton Sep. 22d, 1781.

"Mr. Hodges,
 "Sir,—After considering the great risk you will run in sending the picture by the Coach, with the uncertainty even of its being dry against the time fixed, I conclude it of much less consequence that I should bestow a few days more in rendering the Picture I am now at work on equal to the Original, than to have one totally spoiled in the carriage and the intention of the whole order frustrated thereby. I have therefore sent you the Original as a companion to the other, and you may depend on having the remaining picture returned to you equal to either of the former, and I shall have the satisfaction of completing my part of the order in due time. If these pictures are not sent away till monday, there should be some white of egg given to the Time & Cupid, has it is scarcely dry enough to bear the Carriage.

"Please, if you can, to return by the bearer the Time & Cupid which is to be painted for Mr. Boulton, with the Circle of the Graces breaking Cupid's bow for Mr. Wedgwood.

"I am, Sir, your obt St.
 "JOSH. BARNEY."

"Mr. Jon. Hodges, Soho."

"This was a bad damaged finish'd piece—but repainted and mended for Mr. Boulton.

"This from an impression for Mr. Wedgwood.
 "This on copper finished by somebody, but retouched by Mr. Barney for Mr. Boulton.

"This remains unaccounted for—to be settled by him and Mr. Boulton.
 "These retouch'd in places only.

"This finished very highly from an impression being intended in lieu of an Original one sent Clarke & Green thro' shortness of Time.

"This finish'd from the plain for ordr. Capt. D. A.—F.
 "This finish'd from an impression.

"This do. do. do."

with his sons. One of his sons, we well know, tried photography with Davy.*

"I am beginning to feel jealous about it, and shall anxiously be looking out for the work; it is sure to be interesting.

"I shall endeavour to go over to Trentham to-morrow, without Mr. Powell, and feel about for the desired curiosity.

"Trentham is close to the Potteries, where Wedgwood's home and works are; but I feel convinced they have got the wrong parties. They have got hold of Davy and Wedgwood, not Boulton and Wedgwood. You may depend upon it this secret was allowed to die out with the deaths of Eginton and the Lunatics, and all traces of it were destroyed at the instigation of the Royal Academy and some members of the Government.

"In my old letter-books hundreds of pages have been torn out, besides many erasures.

"Wedgwood, the great potter, belonged to the Lunar Society, and would, consequently, know about the sun pictures; he had four sons, all of them clever. The father would naturally instruct his children in the discoveries of Boulton and the Lunatics: hence Wedgwood and Humphrey Davy trying their hands at it."

No. 27.

"7th Aug., 1863.

"I regret to tell you, I cannot find out anything about the camera. At Trentham there is no one that can recollect it. The man who prepared the inventory of Powell's effects assures me it was not included, and he never saw it. I am fearful it is gone, although Powell says he hopes to trace it.

"The pictures Mr. Hamilton refers to are two curious paintings by Louthembourg; they were sold by auction at our Auction-rooms at Birmingham, and were described as the products of the process of Boulton and Watt. This was directly after those articles appeared in the Birmingham papers."

Extract from Mr. Edward Price's letter, dated November 1st, 1863.

"I do not believe that Davy and Thomas Wedgwood were really the discoverers of photography. I still maintain that the art of taking sun pictures emanated from the Lunar Society, of which Josiah Wedgwood was a member, and by whom the secret, in all probability, was divulged to his son Thomas, who afterwards imparted it, as far as he could, to that clever philosopher Humphrey Davy, and the two set to work to make something out of it, and to a certain extent succeeded.

"I am truly sorry to tell you that Mr. Powell has not yet written to me in reply to my last three notes, and he has not yet sent the photograph which he took from the old camera.

"I believe he is now in the Potteries, about Trentham, Burslem, &c., hunting after the missing relic, and I trust it will turn up after all. I shall write him by this night's post, to tell him to write to you direct in time for Tuesday.

"As to a picture coloured in oil by Eginton, I beg to say that I will send you one copied from the celebrated picture of Murillo's 'The Good Shepherd,' or the 'Infant Jesus.' I think the original is at the National Gallery. You will observe that it is reversed; for instance, the crook is in the hand on the opposite side to where it is in the original. This picture has been engraved over and over again; and a very good impression is in 'Family Devotions' (published some years ago by Tallis), vol. ii. p. 124.

"This copy of Eginton's was given to me by the sister-in-law of Mr. Matthew Robinson Boulton, and I will let you have it, to enable you to see how they finished their work.

"I have also two other oil paintings, copies of Eginton's 'Cupid being bound by the Graces,' and the other 'Cupid being drawn in a Chariot by the Graces.' They are both finished in oil; but they are reverses.

"If you want these, you must please telegraph soon in the morning, as they are not at home, but at my mother's.

"Yours sincerely,
 "EDWARD PRICE."

* "Extract from Miss Metyard's letter, 2nd Nov. 1863.

"DEAR SIR,—You may with safety refer the first experiments in photography to as early a date as 1790 or 1791. In the latter year I find Thomas Wedgwood (third surviving son of Josiah Wedgwood), sending his camera to Birmingham to be mended; ordering silver cylinders, solid in form, highly polished, and turned on a lathe; and desiring to have sent him a coil of silver wire of extraordinary fineness. He has also common barometer tubes blown with a bulb.

"The first process seems to have consisted in laying the nitrate of silver upon paper, and then, by means of the camera obscura and the solar rays acting on the paper, a perfect impression was obtained of any object in half a second; but the image soon faded on exposure to light, and after a while disappeared. Subsequent improvements were made, but the result was not satisfactory, even at a later date, when Sir H. Davy assisted in these experiments. Hence, all early photographs have a faded appearance—a defect probably due to the quality of the chemical agents employed, rather than to a want of manipulative dexterity. This and other chemical experiments were extraordinary, considered relatively to a youth of 18 or 19 years of age, and the then somewhat early stage of philosophical knowledge and analytical training. But even before this, there can be no doubt that young Wedgwood, and his father's resident chemist, Alexander Chisholm (who entered the elder Wedgwood's service in 1781), had worked together in pleasant companionship, and we may very reasonably assume that the two photographs in your possession were the results of this companionship in science. One of the photographs is undoubtedly a representative picture of the breakfast-table at Etruria Hall, as we see upon it articles of jasperware, adorned with cameo-work of the usual kind.

"Thomas Wedgwood, who died, I think, in 1805, was a wonderful man. His philosophical and metaphysical theories were as profound as they were far in advance of his time; and it is said that, in relation to light and heat, he anticipated some of the discoveries of our own age.

"This is all I can tell you. I am neither a philosopher nor a chemist; so please pardon whatever may be incorrect in this statement, though, as far as facts are concerned, it is pretty accurate. I write, too, in a hurry to save time.

"In January, upon my return from Liverpool, I may be better able to add to your knowledge.

"Please consider this as private, except to your Society; for my crude statement is worth nothing, except for the truth of its few facts.

"I am, dear Sir,
 &c. &c."

Extract from Mr. Edward Price's letter, dated November 2nd, 1863.

"These pictures are invaluable to me; they are my only and really last connexion with Miss Wilkinson; and therefore, do take care of them, and return them all safe.

"This Miss Wilkinson is a most extraordinary lady. She was the bosom friend of James Watt, and the sister-in-law of Matthew Boulton. She is still alive, but quite childish.

"These pictures were given to me in Matthew Boulton's library at Soho. Miss Wilkinson said, 'Here, Edward, here are the relics of the Soho; take them, and preserve them as long as you live. The Boultons may not have the honour which may be due to them; but, never mind, the Watt will.'

"I can only repeat that these pictures were given to me by Miss Wilkinson, and she said (many years afterwards) they were the most precious gems in her line; that I must keep them, and show them as long as I lived: they were a mystery.

"My mother has had the two circular pictures at home about 20 years, and I have had the other about 17 years. Neither of them were out of Soho House up to that time for the last 50 years, as I have proofs.

"Yours sincerely,
"EDWARD PRICE"

"I have heard nothing of Mr. Powell and the old photo and camera; but I hope you have."

Other documents bearing on the subject:—

"Mr. Barney. Soho, 25th August, 1781.
"Sir,—I am sorry I was absent when you call'd yesterday. This morning I deliver'd to your man the painting of Telemachus with two blanks for painting the same upon. Messrs. B. & F. have undertaken these pieces at about £7 net. Mem. *not* including their general expences attending the sale, &c.; therefore, as Mr. Boulton desires they may be well executed, he will not stipulate you in the charge thereof, but as you are acquainted what he will get for them, he leaves it to you to render them as moderate as you can, but begs they may be good pieces and exactly alike, for they go as mechanical paintings. I could wish to receive your reply to the above; also to intimate how soon you guess they can be done. Besides these two of Telemachus there are wanted two of Time and Cupid—2 of Jubica and Trenmore (one of which only wants repairing), the other three to be deliver'd in the dead color'd state. The time limited for the whole is to be in London by the end of Sept. Please to signify what of 'em (if not all) you can undertake.

"In expectation of hearing from you soon,

"I remain very respectfully,

"Sir,

"Your obedt. hble. Servt.,
"Jno. HODGES."

"Mr. Hodges.

"Sir,—Mr. Barney was hear last night, and inform'd me he was going to London, and that Mr. B. wish'd him to take the picture of Stratoney to finish from the original of Mr. West, and that Mr. B. was pleas'd to say I might have the picture again when finish'd to correct the coloring of one for my self at my leisure, for which I shall be much oblig'd to him—

"The print of that subject which you Brought is ready for Transferring, and if you have any canvas of that size, it shall be don immediatly and Mr. B. may have his chois.

"I am, Sir,

"Yr. obdt. hble. Servt.,
"FR. EGINTON."

"July 5, 1781."

"Mr. Hodges.

"January 18, 1782.

"Sir,—The plates which I have an immediat ocation for are Time and Cupid, and also Telemachus—and if Mr. B. will pleas to favour me with the respective pictures to finish one of each from, you may depend upon the greatest care being taken of them, and safely return'd by

"Yr. oblig'd hble. Servt.,
"FR. EGINTON."

"Mr. F. Eginton.

"Soho, 17th Xbr, '81.

"Sir,—Inclosed are two impressions, Penelope and Calypso, which you are requested to transfer on the two Copper plates herewith. These are wanted for the same order as the Time and Cupid, Jubica, &c.; therefore I must get 'em done, say finish'd in a mastery stile. The sooner they are done, the more you will oblige Messrs. B. and F.

"I am, Sir,

"Your very obedt. Servt.,
"Jno. HODGES"

P.S. Should an impression of Trenmore be ready, please to send it per bearer, as the others already received wait its arrival.

"Mr. Barney.

"Soho, 15 August, '81.

"Sir,—Your favour I have received, and in reply have to inform you that the following paintings will be wanted for certain by the end of Sept.—viz. Two Telemachus on his return, Two Time and Cupid.

"The last will be deliver'd to you in the dead color'd state; the first to be done from the plain. If you think you can execute these (and perhaps two more pieces) by the time, provided you set off as you mention, please to give a line. I shall prepare the straining-frames, canvass, &c., ready to begin the Telemachus's, and hope for your answer about send; them to W^hamp-ton to be ready against your arrival.

"I am, for Messrs. Boulton & Fothergill,

"Sir,
"Your obedt. hble. Servt.,

"7, Quality Court, Chancery Lane, W.C.

"October 30th, 1863.

"DEAR SIR,—I examined the piece of plate you gave me when last at the Museum, and found plenty of silver upon the coating. I was waiting until you sent me the piece of picture to assay. I am, however, quite satisfied that no silver was in the piece you gave me before.

"I remain,

"Yours very truly,
"DUGALD CAMPBELL."

"F. P. Smith, Esq."

Proceedings of Societies.

SOUTH LONDON PHOTOGRAPHIC SOCIETY.

THE usual monthly meeting was held in the City of London College, Leadenhall Street, on the evening of Thursday, Nov. 12th. The Rev. F. F. Statham, M.A., F.G.S., in the chair.

The minutes of a previous meeting were read and confirmed.

Mr. WHARTON SIMPSON called attention to some fine specimens of Mr. Dallas' photo-electric engraving, and to some charming specimens of art-photography by Mr. Wingfield.

The SECRETARY called attention to a beautiful specimen of card portraiture by Mr. Rejlander, to a portrait by Mr. Miers, and to a transferred albumen film by Mr. Harmer. It had been attached to the concave surface of a watch, coloured in water colours, and then backed up with white; presenting, when the convex side was examined, a very pleasing effect. The Secretary remarked that the specimen was tinted in water colours, but he thought oil would have given a richer effect.

Mr. JABEZ HUGHES exhibited two very fine 10 by 8 portraits taken with Dallmeyer's No. 2 triple lens, open aperture; the exposure in a glass room, with moderate light, was about 30 or 40 seconds. They were especially admired for their roundness and the admirable definition in every part they presented.

The SECRETARY then read a paper on Photography in India, by Mr. Warner (see p. 548), and exhibited some models of the application suggested for preserving moisture.

The CHAIRMAN remarked that possibly they might be found of service in this country during hot weather.

Mr. WALL said he thought that Mr. Warner had scarcely done full justice to Indian photographs. There were in the International Exhibition some vignette heads so fine that he thought he gave them the highest praise when he said they were nearly equal to those of Mr. T. R. Williams.

Mr. ALFRED HARMAN then read a short paper on the proportion of chlorides in albumenized paper (see p. 556). He also exhibited some specimens illustrating the position he assumed. There were four prints from the same negative, a very thin one; the first was on paper prepared with 3 grains to the ounce, and the others with 6, 10, and 15 grains respectively. They were all excited on a 60-grain nitrate bath, and printed, toned, and fixed together. Those with the least salt unquestionably possessed the greatest vigour, but the contrast was not so marked, Mr. Harman observed by artificial light as by daylight.

Mr. WALL asked if it would not be best to proportion the amount of chloride to the quality of the negative.

Mr. HARMAN said that this might be done to some extent, but could not conveniently be carried out thoroughly, as it would be impossible to have a differently prepared negative for every variety of negative. A difficulty arose, moreover, from the unwillingness of manufacturers to state the formula by which their papers respectively were prepared.

The CHAIRMAN asked if it would not be easy for photographers to test these papers, and thus ascertain the proportion of chloride present.

Mr. MARTIN said this might be done by soaking a known quantity of paper in cold water to remove all the albumen. This could then be coagulated by nitric acid, and the amount of chloride present ascertained by precipitating it with a standard solution of nitrate of silver.

Mr. PRICE said that some of the chlorides, barium for instance, formed a compound with albumen, and could not be separated and estimated in this way. He had found he could not get a barium paper because manufacturers said the compound it formed with the albumen caused some difficulties.

Mr. SEBASTIAN DAVIS thought there would be insuperable difficulties in forming a correct estimate. The proportion of albumen on different sheets of paper varied according to the absorbent qualities of the paper, and the temperature of the rooms in which the albumenizing was conducted. The organic salts present would also mar the estimate.

Mr. SIMPSON said it would be clearly impossible from the causes named, and others, for photographers to arrive at a definite estimate of the proportion of salt used, and if it were possible they would not undertake such a troublesome operation. There was, however, a much simpler plan quite within their power. So soon as it was determined to be of vital importance to them to know the proportion of salt used, they had nothing to do but decline to use the paper of any manufacturer who

refused to give them the necessary information. If they declined to use any paper in regard to which a secret was maintained, all difficulty of that kind would soon disappear.

Mr. MARTIN confirmed Mr. Davis's remarks by stating that even the use of a deep or a shallow vessel for holding the albumen solution would cause a variation in the proportion of salt the paper received.

Mr. HART said he thought that any albumenizer would be willing to state the number of grains of active chloride present in his paper if it were demanded, even if he made a secret of the base or bases used. He would be happy to prepare paper with chloride of barium if any one ordered it.

The CHAIRMAN suggested that if the paper bore a mark indicating the strength of salt used it would be an advantage.

Mr. JABEZ HUGHES said he believed that albumenizers had really very little to conceal. The common practice was to use about 10 grains of chloride of sodium or of ammonium to each ounce of solution; the proportion varied from about 8 grains to 12 grains. But suppose they knew all about it, how much wiser were they? The question was still open as to the strength of silver bath required with a given proportion of chloride in the paper. And even if that were determined they were still in a state of uncertainty, for the last sheets, which were albumenized upon any given quantity of solution, would have a larger proportion of salt than the others from the evaporation of a certain amount of water. Again, some sheets were more absorbent than others, and the proportion of salt would be disturbed by that cause. On the whole, he thought that more harm than good would be done by manufacturers stating the proportion of salt the paper was supposed to contain, for it must often be a misleading statement. The point now to be established was as to the advantage of a small proportion of salt. In Mr. Harman's specimens he could not see much difference; there appeared to him to be no greater difference than might be produced by accidental causes in the same paper. Such, at least, appeared to him to be the case in examining them by artificial light, and they did not prove anything certainly as to influence of the salting. There was another question he thought more important and more open to them; he referred to the strength of the silver bath. The strength of this was in their own hands, as they all made their own. A short time ago an impression prevailed as to the importance of strong baths, and 80 grains and 100 grains to the ounce of water were commonly used. He had recently talked with a gentleman engaged very largely in commercial printing who used that strength at one time, who now used no more than half. He now used 40 grains of nitrate to the ounce of water, and made no other difference, but obtained equally good results. Again, Mr. Simpson and himself had recently called upon a gentleman whose name they all knew and respected; he referred to Mr. England. He, they found, was getting most perfect results with 40 grains, or less, because when the bath got low, he still only strengthened with a 40-grain solution. He made this difference, that he added one-eighth of methylated spirit to his solution; that was, he used 7 drachms of water and 1 drachm of methylated alcohol to 40 grains of nitrate of silver.

He entered into no theory on the subject, but simply stated his practice, and showed them his brilliant results. He prepared his own albumenized paper, and practically used $7\frac{1}{2}$ grains of chloride to the ounce. He used 5 grains of chloride of ammonium and 5 grains of chloride of barium, the latter being practically only equal to $2\frac{1}{2}$ grains of chloride of ammonium. If, then, with ordinary paper they could use much weaker baths than they had done, it was very important, and came more home to them than any question about the salting solution. And although it might be urged that any excess of silver used by recovery from the waste, it was certainly much better not to waste it and then have it to recover.

Mr. WALL said he had received a very brilliant print from Mr. Taylor, of Edinburgh, for which a 20-grain bath had been used.

Mr. HUGHES considered that the practice of men like Messrs. Sedgfield and Elliott and Mr. England was of greater weight and more important than that of amateurs.

Mr. HOWARD thought an amateur might well be embarrassed by the number of questions recently raised. It was almost as bewildering as the celebrated card trick. First the difficulties were referred to the tanning bath, then to the silver bath, then to the salting solution. He believed, however, that the paper itself was the basis. During the last 2 or 3 years the consumption of albumenized paper had increased four-fold; the result

was that a worse article was now sent out, not fit for the purpose, and hence the troubles which followed.

Mr. SIMPSON whilst agreeing with the admirable remarks of Mr. Hughes in the main, took exception to one or two points. In the first place, in regard to amateurs, whilst he fully admitted the weight which attached to the practice of such men as Mr. England, felt that the opinions and experiments of intelligent amateurs were often of great value and worthy of due consideration. In regard to the proportion of chloride, whilst it might be very difficult for manufacturers to state precisely the proportion a given paper contained, owing to the disturbing causes to which reference had been made, it might be very easy to state an approximation, and say whether from 5 to 7 grains, or from 12 to 15. As to the value of the knowledge, he might state that his friend, Mr. T. R. Williams, whose pictures everybody admired, was in the habit at one time of keeping a very weakly salted paper expressly for weak negatives, as securing the greatest amount of vigour. He handed round for the examination of members one or two charming prints he had that day received from Mr. Burgess of Norwich, excited on a 35-grain silver bath with 80 grains of nitrate of soda as recommended by a "Photographers Assistant," and one or two he had himself printed on paper excited 3 minutes on a silver bath containing 20 grains of nitrate of silver to the ounce. None of the prints were in any way wanting in vigour.

Mr. PRICE asked if Mr. Simpson's bath were old or new? Mr. Dawson had referred to the action of accumulated nitrates in an old bath.

Mr. SIMPSON said the bath was old, and doubtless contained an accumulation of nitrates of soda or ammonia.

Mr. HART showed some specimens on paper floated three minutes on 70-grain silver bath, and on 20-grain bath, containing 50 grains of nitrate of soda, the former had acquired a greater depth, with the same exposure, than the latter.

Mr. BLANCHARD said that the weak salting bath required, as he understood Mr. Harman, longer exposure. The result was really analogous to what most photographers were familiar with. They were in the habit of printing a weak negative in a slow dull light, in order to get vigour. Here the small proportion of chloride being less sensitive, was equivalent to a slow light, and it was easy to understand that it gave more vigour.

After some further desultory conversation,

Mr. SIMPSON said Mr. Williams had just mentioned to him that he continued to use a weakly salted paper for weak negatives, and that his experience confirmed the suggestions of Mr. Harman.

Mr. HUGHES thought that in referring to weak negatives a fresh issue was raised. Mr. Harman had recommended weak salting solutions for paper generally, without limiting them to that for weak negatives.

Mr. HARMAN had especially referred to weak negatives, in fact to the mass of portrait negatives developed with iron. With a hard negative he would prefer a heavily salted paper.

Mr. HART then exhibited and explained his Volumetric Apparatus.

A paper on "Glass Houses and Lighting the Model," by Mr. Parker, was announced for the next meeting. After votes of thanks, the proceedings terminated.

Correspondence.

SCENIC BACKGROUNDS IN TINTS.

DEAR SIR,—I have just had my attention called to an article in the PHOTOGRAPHIC NEWS of October 23rd, signed "R. A. S.," and which, if left uncontradicted, is calculated to do me serious injury in my business, as it boldly attacks a system which I adopt, viz., the employment of tints instead of greys in photographic backgrounds. "R. A. S." facetiously heads his epistle "A Dozen brief Hints to Portraitists." The word "Portraitists" would lead us to suppose that he meant professional photographers. Yet this cannot be, as he occupies two columns and a half of a journal devoted to the advancement of the science of photography, in telling us that which every one of ordinary capacity must have known before he had been an amateur photographer a week, viz.—that the background should be subservient to the figure—the shadow on the background and figure should

be on the same side—that the point of sight is opposite the lens, and that scenic backgrounds should be correctly drawn, &c. If, then, “R. A. S.’s” “brief hints” are intended for the infant photographer, why not write what he had to say so as to be within compass of the juvenile mind? But no, your intellectual contributor gets so confused with his own eloquence, as to be wholly unintelligible; for instance, he tells, in Hint No. 3, not to have our backgrounds painted in black or white, or anything approaching thereto; but by the time he has got to Hint No. 9, his taste appears to have undergone a radical change, and he is evidently of opinion that a background similar to a chalk-pit most artistic and suitable, for he tells us to have our backgrounds painted in black and white rather than in colours or browns. He further tells us, the argument against colours or browns is here in a nut-shell. The brown is warm, or, in other words, contains red, and so, where the colour is used thin, and where the colour is used thick, presents not only a contrast of light and dark visible to the eye, but a contrast of chemical action only visible in their action on the sensitized plate. These, then, are his clear, lucid, and comprehensive arguments against colours in backgrounds. I confess them to be wholly incomprehensible to me; it is to be hoped they are less so to the infant photographer.

In defence of colours, or rather tints (for “R. A. S.” does not seem to know the difference), allow me to say—and I challenge “R.A.S.” or any artist or photographer to prove to the contrary—that a charming effect is to be produced with tints in the hands of skilful men, not to be approached by greys, and that colour may be used with advantage and without losing any of the soft gradation of light and shade, in proof of which I send you copies of a few of my accessories, painted in tints and browns, together with one in greys by another artist. I say nothing for or against either, but wish each to stand upon its own merits. I would here say, for “R. A. S.’s” special enlightenment, that when a background is badly and gaudily painted, it is not the fault of the colours, but the manner in which they are used. “R. A. S.” in Hint No. 10, tells us, “when we use a background, to adopt the plan first introduced by Mr. Wall, viz., that of having the lower part of our background long enough to be stretched upon the floor of the room, and painted in imitation of earth,” &c. Now, in the first place, I hold that “R. A. S.” has no right to call attention to the productions of any one man, as it partakes too much the character of an advertisement. Secondly, Mr. Wall did not introduce the ground-cloth; it is a simple arrangement which would suggest itself to every one, and was sold by me when backgrounds were first introduced, with this difference—my ground-cloth was on a separate piece of canvas, so that one would serve for any exterior view. The background is allowed to hang over ground-cloth, which is slightly raised at back, so as to hide the joint, and at same time to give perspective to the ground. Mr. Wall’s ground is, however, part and parcel of the background, and this necessitates a fresh ground-cloth for every background—a very good arrangement for the seller, but not so for the buyer. A ground-cloth, painted in perspective, so as to match background and side-wings, was sold by me three years ago, and has been since patented. This arrangement gives the figure the appearance of standing bodily in the apartment, and the background some yards distant from the figure.

I must assert, in conclusion, that “R. A. S.” has supported no arguments in condemnation of tints, and that they have every advantage over greys I am in a position to prove. I hope, if “R. A. S.” is again allowed to occupy two and a half columns of a valuable photographic organ, which we have been wont to look up to for genuine information and instruction, he will confine himself to matters connected with photography. I feel constrained to say, the whole epistle smacks strongly of a disappointed rival; and I hope for the credit of others in the same business as myself, that “R. A. S.” will furnish his proper name in full.

Yours, dear Sir, most obediently, B. L. PHILLIPS.

“R. A. S.” condemned painting backgrounds in *colour*; Mr. Phillips defends painting them in *tints*. There is a great difference between the two things. Those of Mr. Phillips, painted in tints, have given very pleasing photographic results. Had they been painted in positive colours, they would probably have come out hard and unsatisfactory. The article in question was not intended to injure the business of any one.—Ed.]

Photographic Notes and Queries.

TONING AND MOUNTING.

DEAR SIR,—I send you a new formula for toning bath, which has the merit of simplicity, if it has no other; and I may add, I have never had a mealy print with it. It tones in about 20 minutes or half an hour to the colour of the prints enclosed. To 20 ounces of water, common or distilled, by preference the former, add 4 grains of Sutton’s neutral chloride of gold, which contains equal parts chloride of gold and sodium, so that only 2 grains of the precious metal are used. This is the simplest, most economical, and in every way the *best* toning bath I ever tried.

For mounting photographs, I know of nothing to equal gum tragacanth; to $\frac{1}{2}$ ounce of the gum, add two ounces of *cold* water, and in about 24 hours you have an excellent paste, which will keep good at least a month. A good plan is to keep a piece of blue litmus paper in the jar or bottle in which the paste is kept, so that if it turns acid it may be detected at once.—Yours truly, J. BURGESS.

Lower Goat Lane, Norwich.

[The prints accompanying this note are exceedingly beautiful. The paper, we are informed, was excited on a 35-grain bath, with 80 grains of nitrate of soda, as our contributor, a “Photographer’s Assistant,” has recommended. They leave nothing to be desired either as to tone or vigour. The two little girls are exceedingly charming. We have been experimenting with gum-tragacanth as a paste for mounting, and are glad to hear our correspondent’s good opinion of it. We shall have more to say on the subject shortly.—Ed.]

ELECTRIC LIGHT FOR PHOTOGRAPHY.

SIR,—I am much pleased to learn from W. N. B’s letter in your last number, that that gentleman has made experiments with the induction coil before, and that they were in so far satisfactory; it encourages me in the belief that with the considerably improved coils, and carbon points, in a vacuum, a splendid and cheap light may be obtained.

I beg to say that I shall very shortly make a series of experiments with the coils of a good Birmingham maker, and, along with the results of them, publish the address of the maker.—I remain, Sir, yours truly, AUGUST BUSCH.

14, Clifton Crescent, Asylum Road, London, S. E.

Talk in the Studio.

MORE PIRACY.—On Wednesday last, at Marylebone Police-court, Messrs. Spencer, Turner, and Boldero, linendrapers, of Lisson Grove, were fined for selling, without the consent of Messrs. Southwell Brothers, of 16 and 22, Baker Street, Portman Square, spurious copies of a photograph of Miss Ruth Herbert, as Diana, in the burlesque of *Endymion*; of George Vining, as Captain Hawkesley, in *Still Waters Run Deep*; also, a group copy of John Toole and Paul Bedford, in *The Flowers of the Forest*; in all of which there is a subsisting copyright in favour of Messrs. Southwell. The fines inflicted for three convictions were respectively 20s., 10s., and 10s., with 6s. the cost of the three summonses. Mr. Caldecott, of Praed Street, Paddington, was also convicted for selling copies of the same cards, and for each of the three offences fined 6d. without any costs! The cases were too clear to admit of any other issue than a conviction, but the magistrate, apparently to express his want of sympathy with the prosecution, saddles the complainant with the cost of obtaining the remedy the law provides, and couples his decision with insulting remarks. The complainants suffer a wrong in purse and reputation in having

their productions pirated and sold at 1½d. each. They proceed in the most simple and straightforward manner, without vexatious litigation or undue annoyance, to avail themselves of the provisions of an Act recently passed expressly to meet such cases, and Mr. Yardley, by the injudicious use of his judicial discretion does his best to render that Act nugatory. If this kind of thing be repeated it will call for remonstrance which shall be heard and must be heeded.

PHOTOGRAPHY AND FORGERY.—The Swiss, named Rinaldi, convicted some time ago of causing a forged copy to be made of an Austrian bank note by means of photography, recently appealed on two points reserved at the trial:—1st. Is a photographic impression on glass, such an engraving or making on any plate whatsoever anything purporting to be the note of a foreign prince, or an undertaking for the payment of money of any foreign State, as is contemplated by the statute. 2nd. Should the indictment not merely have charged the prisoner with an attempt or intention to engrave or make, and not with engraving or making? Mr. Metcalfe, for the prisoner, contended that as the photograph here was merely a "positive," and had to be transferred to a "negative" before it could possibly be engraved on metal, it was no engraving at all, but a mere evanescent shadow, which could not come within the Act. As to the second point, he urged that the police had seized their victim too soon, for he had only taken the first step towards engraving. He admitted that engraving on a glass plate was within the Act, but not only did the positive require to be converted into a negative, but the prisoner had directed the negative to be taken to an engraver, that the final engraving which was contemplated by the Act might be executed on metal. The Lord Chief Justice thought the conviction right. The case clearly fell within the very words of the statute. The process which the prisoner had adopted, put on a plate of glass the exact form of words, undertaking to pay money of a foreign state, more exactly than anything which the Arts had yet discovered. As to his being a victim, he was only victim in having lost an opportunity of deluging the country with the notes he intended to produce. Conviction affirmed." An amusing ignorance of photography appears to have been shown by the prisoner's counsel in speaking of the glass positive, or unintensified negative, as being an "evanescent shadow" requiring to be "transferred to a negative."

THE PHOTOGRAPHIC IMAGE.—Some recent experiments have recently induced Mr. Malone to suspend his opinion as to the metallic character of the Photographic Image. He blackened chloride of silver in combination with organic matter by light, and then mixing it with gelatine submitted it to the action of hyposulphite of soda, after which it was treated with hot nitric acid. It was not acted upon, however, as he had expected. He suggests that possibly each molecule of chloride of silver blackened by light still retains a minute core of unaltered chloride, protected from the action of light by the blackened surface, and that a voltaic action is thus induced which prevents the portion really reduced to the metallic state from being affected by nitric acid.

VERY RAPID COLLODION.—A correspondent of *Le Moniteur* gives the following:—"Prepare a concentrated solution of caustic potash in alcohol, and add of this one or two drops to each ounce of collodion. A slight precipitate will follow, and the collodion will become white. It can be used as soon as it is clear; but it does not retain the great sensibility confirmed more than a few days. It is desirable to excite in a small quantity of silver solution, as it has a tendency, with this collodion, to get out of order. It can be corrected, however, in the ordinary way."

CHAPPUIS'S PATENT REFLECTORS, for photographic purposes. These reflectors, generally used in dark warehouses, ships, apartments, &c., are now applied to photography.—P. E. Chappuis, patentee and photographer, 69, Fleet-street.—[ADVT.]

To Correspondents.

CORNISH GROUP.—Your negative arrived in a score of pieces, from none of which could we form any idea of the lighting of your sitter. A piece of card is useless to protect glass going through the post. Why have you blocked out all your side light? Send us a print, and a more detailed description of your glass-house, and we will try to help you.

E. B.—If you wish to protect every view of the house, you must register

the whole. Any view you do not register may be copied. 2. The paper may be used, but a blue tint would be better than green.

JAMES.—Intensifying with bichloride of mercury may be conducted in white light. 2. A few drops of strong ammonia in an ounce of water is sufficient to blacken the mercurialized film.

J. SIDDOES.—To convert a half sovereign into chloride of gold, proceed as follows:—Place it in a jar, and pour upon it 3 drachms of hydrochloric acid 1 drachm of nitric acid, and two or three drachms of water. Let this stand on a sand bath, or on the hob, so as to keep a gentle heat. In the course of a few hours examine, and keep adding more mixed acid every few hours until solution is complete. Now increase the heat slightly to evaporate the acids, but take care not to raise the temperature too much. When the acids are driven off the chloride will crystallize. It is not necessary to do this completely, however, as water may be added so as to make a solution of a definite strength. Half a sovereign will make about 86 grs. of chloride of gold. It is probable that some traces of silver and copper will be present, which might, by taking further trouble, be removed, but it is not of practical importance to do so.

SAOITARIUS.—One of the most useful manuals you can consult is that of Mr. Hughes; also "Bland's Practical Photography," and our ALMANAC. You would unquestionably gain immensely by a few practical lessons from a competent person. If you send us a stamped envelope we will send you the address of a good teacher with whom you may communicate as to terms. We cannot give you any better formula for the use of formic acid than those which have recently appeared in our pages. 2. We prefer neutralising and sunning to boiling the bath. There is room for improvement in your card.

YOUNG PHOTO.—On the whole the ammonia-sulphate of iron possesses the balance of advantage chiefly because it has less tendency to peroxidize. 2. The purpose of acid in the developing solution is to restrain the reduction from being over-rapid, and thus prevent fog, &c. Citric acid is much more powerful in restraining than acetic acid. The kind of acid used modifies the character and colour of the reduced image. 3. A stop is never used between the lens and ground glass, as it would cut off part of the image. It is used between the front and back glasses of a lens, and the rapidity of action is governed by the size of the aperture. 4. Whatever size of view your camera will take, it will take the size in portraits. You have got hold of some imperfect and erroneous idea. 5. Many articles on the solar camera have appeared in our pages; the most complete as a description perhaps appeared in No. 75.

QUEER.—The spots are caused by imperfect fixation from the hypo being too weak or the prints not properly immersed: very probably air bubbles have prevented perfect action.

FOGGO.—The best developing solution for producing silvery white positives is that of protinitrate of iron, which we have repeatedly given and which we shall repeat in our forthcoming ALMANAC. We presume that the enamelled iron plates are kept by various dealers; but we do not know of any especial house.

B. MENA.—The lens you have is not suited for card portraiture. The only mode of securing definition at the edges with it, is by using a small stop. We cannot answer your other question here. Send us a stamped envelope and we will write. Your card is a little short of exposure and lacks in definition. The printing is pretty good.

M. WILLETT.—The letter was duly forwarded.

E. M. T.—Some samples of paper are very prone to turn red in the hypo; when such is the case your only remedy is to tone deeper. It is sometimes the fault of the negative, which, being thin, does not permit sufficiently deep printing to give black tones. You need not fear being laughed at. We see nothing comical in persons wishing for information: there was a period in the history of all men when they were ignorant of what they afterwards knew. The last remark is so much of a truism or platitude that it almost sounds absurd, nevertheless, many persons are constantly forgetting it.

PHOTO (Tainton).—You should have stated what your present formula is when you wish for some improvement upon it. See our first article. If you do not glean what you want, write to us again.

WILLIAM THOMPSON.—We do not know of any effectual plan of restoring faded photographs. Several methods have been proposed; but so far as our experience is concerned they are uncertain and unsatisfactory. 2. There is no special work on the albumen process. Many articles on the subject have appeared in our pages. 3. Our ALMANAC will be ready in a few weeks. A varnish of india-rubber solution will probably make the calico light tight.

M. O.—Yours appears to be a very hard case, and if correctly stated, you are the victim of heartless and dishonest conduct. We do not see how we can help you, as you have entered into a foolish bargain; you have bound yourself to hard conditions without binding your employer to any. He can still hold you to your conditions, and at the same time turn you adrift. Nevertheless he will not have the hardihood, we think, to prevent you getting employment wherever you can.

PAPER DRAPER.—We do not remember any such advertisement, nor quite understand the meaning of the term. If you can explain more fully what you mean we shall have pleasure in helping you.

SUFFERER.—We do not know the name or address of Nemo; but have sent your letters to his agent, who promises they shall receive attention. Several Correspondents in our next.

Photographs Registered during the Past Week.

- MR. HENRY BRROGER,** 23, Clearview Street, Jersey,
Two Photographs of M. E. Renan, Author of "The Life of Jesus."
- Messrs. W. and D. DOWNEY,** 9, Eldon Square, Newcastle-on-Tyne,
Photograph of the Right Hon. Sir Charles Wood.
- MR. A. S. WATSON,** 2, Regent Road, Great Yarmouth,
Three Photographs of E. Bellasis, Esq., Sergeant-at-Law.
One Photograph of Lord Hastings.
- MR. J. C. VYE PARMINTER,** Swansea Portrait Studio, Swansea,
Photograph of the Rev. Charles Rawlings.
- MR. WILLIAM GUTHRIE,** 23, Nuns Street, Newcastle-on-Tyne,
Photograph containing portraits of Miss Emily Cross, Mr. Sidney Davis, Marcus Elmore, in character, as they appeared in the "Ticket of Leave Man."

THE PHOTOGRAPHIC NEWS.

Vol. VII. No. 273. November 27, 1863.

CONTENTS.

	PAGE		PAGE
Prizes of the Society of Arts	565	New Process of Engraving	571
Photographic Progress	565	New Photog. for Obtaining Portraits at Night. By M. Mc A. Gaudin	572
On the Tannin Process. By W. Warwick, King	566	Proceedings of Societies—North London Photographic Association	572
A Tribute to the Amateurs. By Mr. Jabez Hughes.....	567	Correspondence—Transferring Negatives to Gutta-percha—Qui Capit, Ille Facit—Photographic Lenses and Distortion—In Self-Defence—Photography in Colours	574
Jottings from the Note-Book of a Photographer's Assistant. No. VI.—Alkaline Toning Solutions considered	568	Photographic Notes and Queries—Stormy Weather and Photography	575
Photographic Residues. By Jacob Ewing	568	Talk in the Studio	575
Photography in the County Court—Jno. Louis v. Schmadhorst and Heilbronn	569	To Correspondents	576
Researches on Positive Printing. By MM. Davanne and Girard	569	Photographs Registered during the past Week	576
1st.—Toning with Acid Chloride of Gold	569		
A Few Words in Regard to Lighting Operating Rooms for Portraiture	570		

PRIZES OF THE SOCIETY OF ARTS.

Is the list just issued of subjects for premiums to be distributed by the Society of Arts, during the sessions 1863-4, and 1864-5, are several entries to which we desire to call the attention of photographers. Despite all the arguments to the contrary which have at times been urged, and despite the petty jealousies and discontents which sometimes arise out of the awards, the system of prize-giving is incontestably a stimulus to emulation and competition, and these to improvement and progress. The premiums offered by the Society of Arts have been, in times past, productive of much good, from which the public at large have reaped solid results; and we do not doubt that the prizes offered in the list just issued will materially aid in giving point and direction to ingenious effort and inventive energy in the coming sessions. Various improvements and desiderata in photography, and the allied arts, are set down for prizes. The subjects are, as might have been anticipated, chiefly those improvements in photography in relation to ornamental purposes and to economies; the processes desired being such as are of the utmost importance in themselves, and well worthy the best energies of the ingenious photographer. We shall look with much interest for the issue, and hope that a brisk competition will be followed by the most perfect results.

The subjects for which the Society's medal is offered are as follows:—

PHOTOGRAPHS ON ENAMEL.—For the best portrait obtained photographically and burnt in in enamel.

PHOTOGRAPHS ON CHINA.—For the production of a dessert or other service, in china or earthenware, ornamented by means of photography and burnt in from an impression obtained, either directly from the negative, or from a transfer from a metal plate obtained directly from the photograph.

PHOTOGRAPHS ON GLASS.—For a table service in glass ornamented by means of photography, under similar conditions to the above.

PHOTOGRAPHS ON WINDOWS.—For the production commercially of ornamental glass for windows by means of vitrified photographs.

There are many other subjects for which prizes are offered which may interest the chemical and photographic experimentalist, such as a rapid means of reproducing designs for calico printing, in which it is probable photographic engraving and block-printing may be found useful; for a cheap spectroscope; for a simple and efficient dialysing apparatus; substitutes for albumen, &c. For details regarding these, we must refer our readers to the Society's published list.

We subjoin the conditions of competition which it will be seen are wide and liberal, taking no advantage of any kind of the competitor, but affording him the fullest opportunity of deriving the fullest profit, as well as honour from his invention:—

Patented inventions are not excluded from receiving the Society's awards.

The Society is willing to receive communications on subjects not included in the following list, but in all cases expressly reserves the power of rewarding any communication according to its merit, or of withholding the premium altogether.

The degree of originality and extent of suggestions for improvements will have material influence on the adjudication of the award.

In all cases a full account and description of the invention for which a premium or medal is sought must be sent to the Society.

All communications must be written on foolscap paper, on one side only, with an inch and a quarter margin. They must be accompanied by such drawings, models, or specimens as may be necessary to illustrate the subject. The drawings should be on a sufficiently large scale to be seen from a distance when suspended on the walls of a meeting room.

In regard to Colonial Produce of all kinds, it is absolutely necessary that a certificate from the Governor, or other qualified person, should accompany the samples sent to the Society, certifying that they really are the produce of the particular district referred to. The samples should be sufficient in quantity to enable experiments to be made, and an opinion to be formed of their quality; and it is desirable that the cost price in the district from which they are forwarded should be given. In every instance the probable extent of supply, with the average yield, if cultivated, and whether similar articles have hitherto been exported from the colony or not, and in what quantities, should be stated.

All communications and articles intended for competition must be delivered, addressed to the Secretary, at the Society's House, free of expense, either on or before the 31st of March, 1864, or on or before the 31st of March, 1865, except where otherwise stated. In the first case they will be considered during the session 1863-64, in the second case during the session 1864-65. This restriction, as to the date of receipt, does not apply to articles of colonial produce, in respect of which this list is valid until 31st December, 1865.

A communication rewarded by the Society, or any paper read at an ordinary meeting, will be considered as the property of the Society. Should the council delay its publication beyond twelve months after the date of its being rewarded or read, the author will be permitted to take a copy of the same, and to publish it in any way he thinks fit.

Unrewarded communications and articles must be applied for at the close of each session, between the third Wednesday in June and the last Wednesday in July, after which the Society will be no longer responsible for their return.—By order,
October, 1863. P. LE NEVE FOSTER, Secretary.

PHOTOGRAPHIC PROGRESS.

AMONGST the many signs of the prosperity of photography and of its growing and extending importance, we are glad to record the establishment of photographic societies in places where, until recently, nothing of the kind existed. A photographic society is at the present in course of being established in Berlin. A provisional committee has been appointed to make the preliminary arrangements, and to invite the leading photographers of the city to a general

meeting for completing the organization. Amongst the members of the provisional committee we are glad to find the name of Mr. J. W. Osborne, who is prosecuting his photolithographic experiments in that city. The other names are those of Dr. Vogel, and Messrs. Beyrich, Günter, and Suck. We hope shortly to record the further progress of the society. A photographic society has recently been established in Spain, and a journal entitled *El Propagador de la Fotografía*, established. In Italy, the new photographic journal established a few months ago, entitled *Il Camera Oscura*, is, we understand, progressing satisfactorily.

In the Southern quarter of the globe, we regret to say, matters do not look so satisfactory. The *Hobart Town Weekly Times*, from which we quoted, some months ago, an announcement stating that a movement for the establishment of a society was contemplated, informs us in a recent number of the complete failure of all attempts to excite a public or co-operative spirit amongst the photographers of Tasmania. The Editor of the Journal to which we have referred, set aside a column of his paper for the purposes of photography, inviting letters, articles, discussions, &c. He now gives the matter up in disgust. He has himself supplied a series of articles on interesting photographic topics; but has not received, during the four months which have elapsed, a single communication of any kind, good, bad, or indifferent. For the present he bids his photographic friends adieu, with the statement that journalism of any kind, without encouragement, is very uninteresting, but scientific journalism is, under such circumstances, simply unbearable.

ON THE TANNIN PROCESS.

BY W. WARWICK KING.*

As this process is not one of my own discoveries, I do not intend to say that it is certain, but speaking as one who has tried it with comparatively large plates (which are surer tests than small ones), I can safely say that I believe it to be nearer certainty than any other of the dry processes, and decidedly more simple. Every dry-plate photographer must acknowledge the value of Major Russell's work on the Tannin Process, though its usefulness is much impaired by the want of an index and marginal notes; but for my own use I have been largely indebted to my friend the Rev. J. C. Browne, who has practised the process with great success.

Having but little time for photography, I am unable to experimentalize; but as some encouragement to those similarly situated, I beg to offer a few observations, not that I can hope to communicate any novelty, but simply to place on record my own experience. Valuable as theory is to the art in general, yet more valuable to its ordinary followers, is practice, and if members would only give the results of their practice, or make notes of anything which they have observed in the course of their work, and communicate those notes to a society at one of its meetings, in the shape of a paper, instead of writing letters to the journals, I feel that much good would be done. I will now come to the subject for our consideration this evening. The plates must be cleaned with the utmost care. I have traced nearly every defect in the process to dirty plates. I discard gelatine, or any preliminary coating, because its application is troublesome, and only tends to complicate the process. We may rest assured that any addition which is not of positive good is a step in the wrong direction. The more we simplify a process the better.

I use Thomas's bromo-iodized cadmium collodion. I prefer it newly iodized—say, three days; and his bath, which is 30 grains, and neutral. I have worked with a bath containing 25 grains to the oz., but think the greater strength safer. It greatly conduces to the photographer's peace of

mind if he knows his preparations are correct. Having coated the plate as usual, wipe off with the hand any steam which has collected on the back of the plate, or the circle made by the pneumatic holder will appear in all the subsequent treatment. Dr. Kemp says, use a cloth for this purpose, but the said cloth is apt to produce fluff, which finds its way into the bath, and must, when there, be detrimental. Let the plate remain in the bath till all oiliness is removed, then immerse it in distilled water in a glass dish, moving it up and down occasionally till all oiliness disappears. Let it remain in the dish for 3 minutes. Then wash it well back and front under a tap for three minutes longer. Then swill with distilled water, and drain slightly. It is advisable to keep a small basin of water at hand wherein to dip the fingers after they have come in contact with nitrate of silver. This will prevent stains at the corner by which the plate is held. If any red stains appear, reject the plate at once; but if not, filter through two folds of fine muslin enough to cover the plate of

15 gr. tannin,

1 oz. aq. dist.;

Throw away the first portion, and then pour on a second, allowing it to remain a minute or two; then stand the plate up on one corner to dry, resting on clean blotting paper; never use the same portion twice. (A funnel with the stem broken off, leaving only the bowl, will be found very useful in filtering into measures). I generally mix the tannin solution eight hours before use. Any tannin seems to produce good results, but I always keep some which I procured from Mr. R. W. Thomas, because it dissolves immediately, and is perfectly clear without filtration. This is handy in the event of my requiring any tannin for immediate use. While speaking of tannin, I must name one precaution, that you do not let a drop of solution fall upon the glass while it is in the distilled water dish, or a spot will be produced which cannot be removed. The plate may be left to dry spontaneously. Major Russell says that the sensitiveness is increased by drying up to a certain point, and beyond that being diminished again; but I have found on looking at my plates the morning after their preparation that they are not dry; and then the placing of a stone jar filled with hot water in the drying box will cause them to dry rapidly without producing any ill effects; or the stone jar may be put in the box directly after the plates are stood up to dry, without, as far as my observation goes, sustaining the slightest injury. The plates, when dry, should present a polished surface. They are then so far good, but the surface must not be touched with the fingers, or a mark will be produced which cannot be got rid of.

With regard to the exposure, I cannot say that it is more rapid than the other dry processes. I find the average to be about 8 minutes in the spring and 20 minutes in the autumn, with a Grubb lens, for 9 by 7 plates, one-third inch aperture, 12 inches focal length for an ordinary subject, such as a stone building without any very dark trees adjacent. I always prefer to see something of the image before development, as then I know that, with care, subsequent operations will go on well. Before developing, varnish the edges of the plate with a solution of white wax dissolved in benzole; this will prevent the film from detaching itself from the glass. When this is done, place it on a levelling stand, and spread distilled water over the plate by means of a glass rod; let the water remain on for 3 or 5 minutes according to the temperature, which should not be lower than 60; then apply the developing solution,—

Pyrogallic acid... .. 2 gr.

Aqua dest. 1 oz.

Add thereto, according to the size of the plate, 1 drop of

Nitrate of silver 10 gr.

Citric acid 10 "

Aqua dest. 1 oz.

to each drachm of the first-named solution. Pour on and off till all the detail is well out; when this appears, inten-

* Read at the North London Photographic Association, November 15.

sify by adding a few drops of a second solution of nitrate of silver:—

Nitrate of silver	10 gr.
Citric acid	40 "
Aqua dest.	1 oz.

This strong acid solution will keep the developing solution clear during the intensifying. Where the image is sufficiently intense, wash thoroughly, and fix with—

Hypo	2 ozs.
Water	4 ozs.

Lastly, let running water from the tap fall on the plate for ten minutes, to remove the hyposulphite of soda.

One is apt to over-intensify, but I have found that a saturated solution of hypo will reduce the intensity, while that which I have given will not.

As to the keeping quality of the plates, I can say that they do not seem to deteriorate with exposure five weeks after their preparation, and may be developed a fortnight after exposure.

Before concluding, I will give a few hints to those about to take their cameras to the North of Europe:—

1st. Avoid the concertina form of body for the camera, as that contrivance harbours dust. Mr. Kinnear's original idea of velveteen, or something of that kind, is far preferable.

2nd. Pack your plates in grooves of cartridge paper; then in thin gutta-percha; then in sheet lead; and finally in brown paper. They will then travel safely, and not take up much room.

3rd. Do not take new apparatus to Denmark, or the Custom House officials will think you want to sell or patent it. You will meet with no difficulty whatever in Sweden, the enlightened rule of the government permitting all scientific instruments to pass free of duty, and you are treated with the greatest courtesy by the Göteborg Customs' officials; but it is otherwise at Copenhagen. There the Customs' officers seem to have taken a lesson from the Prussian officials, for they stopped my camera, suspecting and suggesting things which never entered my mind, and made themselves objectionable in every way. Their conduct will account for your having the paper now read instead of one which I hoped to have given you this year, and still hope to read next year, on a photographic trip in Denmark; for although the country is flat, there is much that would interest the photographer, archaeologist and artist.

A TRIBUTE TO THE AMATEURS.

BY MR. JABEZ HUGHES.

IN reference to the two divisions of photographers—the professionals and the amateurs—it cannot escape notice that the former often look on the latter with jealousy, and sometimes spice their remarks on their amateur brethren with unnecessary illiberality.

During the discussion at the last meeting of the South London Photographic Society, some words fell from me which, judging from the reply of Mr. Simpson, were held to be of this ungenerous nature. I express my regret that my words bore that interpretation, as my views are of quite an opposite nature. Although the wide-spread and extensive practice of the art depends on the professionals, yet these must never forget that all the original discoveries, great improvements, and marked advances are made by the amateurs. Who formed the first photographic society, and established the first photographic journal? The amateurs. They formed the bulk of the members, and for many years were the exclusive managers, and remain so almost yet. The provincial societies principally rely on the amateur element. The bulk of the papers read at societies, and of communications sent to the journals are by amateurs. Who introduced the present method of so-called alkaline gold-toning? Mr. Waterhouse, an able amateur of Halifax. Who invented the ammonio-nitrate method of printing? The

veteran amateur Dr. Alfred Taylor. Who even discovered the present collodion process but a calotype amateur, Scott Archer, assisted by two other well-known amateurs, Dr. Diamond and the late Mr. Peter Fry. Some time previously, two professionals, one a calotypist and the other a daguerreotypist, Mr. Bingham and Le Gray, used the material, collodion, and made nothing of it; but the amateur, Scott Archer, and his friends matured the process almost as it now stands. Of the few improvements made in it, from where have they emanated? The use of protosulphate of iron was made known by that veteran amateur, Robert Hunt. Dr. Diamond and Mr. Ellis discovered the developing powers of protonitrate of iron. A French amateur, Le Moync, brought out cyanide of potassium, and Sir John Herschell hyposulphite of soda. The use of bichloride of mercury, to make a white positive or a dense negative, was taught by Scott Archer.

He also invented the first camera to take pictures with in the open air. Formic acid was first made known by the Rev. Lawson Sisson, and pyrogallic acid was introduced by Mr. Archer. Of bromo-iodized collodion, the earliest published account is by the late Mr. Berry (then of Apothecaries' Hall, Liverpool), in 1853, and is described in the first paper read before the Liverpool Photographic Society. Plain bromized collodion, as recently introduced by Major Russell, had its early advocates in Mr. Crookes, M. Laborde, and Sir John Herschell.

The various modifications of the collodion process seem all to have originated from the amateurs. The first, though not successful, preservative process emanated from Messrs. Spiller and Crookes. This was speedily followed by the more practical honey process of Mr. Shadbolt, a process long a favourite one, and still practised by many. Then followed Mr. Llewellyn, with the oxymel, and Dr. Hill Norris, with the gelatine processes.

To glance at the numerous dry processes, commencing with Dr. Taupenot's collodio-albumen and Mr. Fothergill's, down to the labours of Major Russell in his tannin process, would only be to name a long list of amateurs who have more or less distinguished themselves in aiding photographic progress.

In vain we look for any original impulse from the professional fraternity.

Even in the matter of lenses, witness the elegant, and now universal, method of introducing the diaphragms. This was invented, not by a professional, but an amateur—Mr. Waterhouse; and recent testimony goes to show that the essential part of the triple lenses is due to the suggestion of Mr. Rothwell.

With all these facts before me, I could not treat lightly the labours of the amateurs.

Upon second consideration, however, it is not to be wondered that the impulses forward should emanate rather from the amateur than the professional. The former pursues the art for *pleasure*, the latter for *profit*. The one can try all manner of experiments, and whether he succeed or fail he secures his object—agreeable occupation. The professional, however, has all his energies directed to make things pay. He has too much at stake to speculate. He chooses the safest way. He is the true conservative, and when he gets hold of anything that works passably well, changes with reluctance. If an amateur experiment with a new toning bath on a batch of perhaps half-a-dozen prints, and fails, well, the loss is not great, and he gains in knowledge and experience. But the professional has his batch of perhaps six hundred; and if he fail, the loss is something considerable, to say nothing of the interruption of business. Many an experiment apparently succeeds from the limited nature in which it is tried. Amateurs' experiments are nearly always necessarily on a small scale. For this reason a distinction must frequently be drawn between their results and the professional man, who proceeds in an extensive manner. If my amateur friend tells me that I need not use my sensitizing bath for my albumenized paper so strong as 80 grains per ounce; that he is convinced by his experience

that 40 grains are quite enough, I, who believe in strong baths, may well shake my head and say that, "Your experience is too limited for me to take you for a guide. You sensitize perhaps two sheets per day on your bath, and that does not materially weaken it; but I may sensitize 50 sheets, and this materially alters the matter."

It was with these impressions that I drew a distinction between the conclusiveness of the experiences of such gentlemen as Mr. Taylor and Mr. England. Though both of them were right in using a weak silver bath, yet it is almost unavoidable not to attach more importance to the superior conclusiveness of the one gentleman's over the other. One practises on a very much larger scale than the other, and whether the plan will succeed on a large scale is exactly the point in question.

The advance of photography is something like the progress of an army. The main body keeps in safe marching order, while the more daring and adventurous are the pioneers who lead the way—rushing here, feeling their way there; always skirmishing, often retiring, but eventually succeeding in finding new tracks and safe paths for the main body to securely pass along.

In this way I look on each section as performing its own allotted task, the united result being the advance of the art.

JOTTINGS FROM THE NOTE-BOOK OF A PHOTOGRAPHER'S ASSISTANT.

No. VI.

ALKALINE TONING SOLUTIONS CONSIDERED.

TRADITION informs us that a certain philosopher, named Frankenstein, with wondrous skill and perseverance, gave existence to a clay-constructed monster, that subsequently proved an ever-linging source of terror to its wretched creator. In modern times, a clever photographer, Mr. Waterhouse, with praiseworthy motives, brought into notice a pigmy, whose mischievous pranks have proved a grief-yielding plague to thousands. Like the god of love, it wounds each Telemachus that attempts to fondle or press it to his bosom.

When the gentleman before alluded to introduced his new method of toning, he attached to the solution a quality which should have been shorn of absolutism ere it was so universally admitted in the photographer's vocabulary, for never was a greater error conceived than that which demands alkalinity in solutions intended to impart satisfactory tones to sun prints, for under such unlimited conditions unfailling results may be pronounced a simple impossibility.

When a surface of reduced chloride of silver is submitted to the action of a strongly acid gold solution, a decomposition ensues, that proves the substance of which the print is composed to be the disturbing cause, because, in the absence of such influence, gold in solution will remain undecomposed for any length of time, when associated with a portion of free acid.

Chemical decomposition is produced by superior affinities. Chloride of gold derives its three equivalents of chlorine from the hydrochloric acid, to whose biting influence the metal has been exposed. If a portion of chlorine is removed, a way is opened for a fresh attack, if any acid is present, for chemical laws are imperative, and the substance last named can remain quiescent only when the gold holds in combination its proper quantum of chlorine which it seems to retain with a very unwilling grasp; consequently, the superior attractions possessed by the silver cause a speedy separation, and the chlorine immediately proves its gratitude by exercising its devouring propensities on its liberator, weakening the print and imparting a false colour, which dissolves out in the hypo bath. The change produced by the attack of free acid on the subchloride of gold would be difficult to determine, but that it assists decomposition may be proved by the fact that its presence causes toning action to move in proportion to the quantity of acid the solution contains, whilst

with the same solution, minus acid, the gold, instead of imparting colour to the print, remains for a time inert, then gradually is precipitated, as has been proved a thousand times by all who have perseveringly adopted carbonate of soda toning. Free acid, whilst encouraging decomposition, doubtless lends its corrosive powers to aid the chlorine in demolishing the structure on which the gold should rest *when precipitated*; hence excessive bleaching, by destroying the foundation, removes all possibility of any molecular arrangement being effected by the colour-yielding agent that will produce anything more than an unsightly slatiness. From the above remarks it will be clearly perceived that a sample of gold containing but a slight trace of free acid, should, with a degree of over-priming, to meet the conditions required by the unassisted chlorine, impart to the prints a satisfactory colour.

The new toning bath proposed by Mr. Burgess admirably illustrates our meaning. He uses what he terms a neutral sample of gold; but from the fact that such an article can be produced only by an expensive method, we may safely conclude that a trace of free acid may be recognised, which is an assisting rather than a deteriorating quality, as we have before shown. With such a sample of gold as described by Mr. Burgess, the silver invites chlorine, but chlorine is in no hurry, as there is no large amount of acid to hasten its departure. It therefore takes its time, and separates too slowly for the exercise of much bleaching action; and whilst the gold deposits evenly, the good offices of the chloride of sodium is engaged in preventing an outbreak on the part of the noble metal, whose services remain uncalled for. With such a toning bath as recommended by Mr. Burgess, warm tones may be secured; but, for reasons to be recorded hereafter, we believe a black hue can be produced by the same solution only when a portion of the chlorine has been separated from the gold by heat applied previous to toning operations commencing.

But to return once more to Mr. Waterhouse. That gentleman perceiving the impossibility of toning satisfactorily with the then existing samples of gold, very sagaciously hit upon the true cause of failure; and this knowledge soon suggested a remedy, viz., removing the excess of acid by the addition of an alkaline substance; hence the name by which his solution was unfortunately introduced. We attach this last quality because, without due examination, we one and all rushed to a conclusion that the superior results were due to some change effected in the gold by alkalinity; and in this belief photographers may see the rock on which many a promising batch of prints has foundered, which loss would have been prevented had a trace of acid remained to steer them clear of the danger.

"Well," observes an intelligent reader of this "jotting," "what is here written is good enough in its way; but my solutions have worked well in the absence of an acid, which fact has been proved by the testing medium called litmus paper." The mode of testing referred to is a deceitful one. In our next paper we hope to show that a known quantity of acid may be present in a toning solution, and litmus paper will give no evidence of its presence. With respect to other toning formulas where soda forms the base of substances introduced with the gold, but little need be said of them by way of explanation. It will be readily perceived that acetic, phosphoric, and other acids, being more powerful than carbonic, are not so easily displaced, and for this reason they are unfit for toning baths intended for immediate use, but this disadvantage is atoned for by the keeping qualities it imparts to the solutions. In our next and last paper on toning, we shall treat somewhat further on this subject, and at the same time enter at length on the mysteries believed by many to exist in the process of lime toning.

PHOTOGRAPHIC RESIDUES.

BY JACOB EWING.

THAT the subject of photographers' silver and gold residues is now becoming one of importance, will appear from the

fact, that the Editor of the NEWS, ever ready to further the interests of photographers, has quoted and rightly recommended for adoption in this country, a method now about to be practised by a transatlantic speculator for the recovery of such *mis-named wastes*, and one which, if properly acted on, promises to give to the profession a means of avoiding much trouble and anxiety, at a stated per centage for labour expended.

This is to be looked upon as a step in the right direction, and if it be possible to reduce it to a practical bearing, and so do away with any doubts that may exist in regard to the intrinsic value, when taken away in a moist condition from photographers' places of business, and reduce the bother attached thereto, the plan would indeed be valuable. That such a scheme, or similar, is a desideratum is undoubted, as the photographer at present has great cause to entertain such unpleasing doubts, many strong cases serving to prove that he has been made the victim of some houses that advertise their willingness to *reduce* (and that too often with a vengeance) *photographers' waste*.

One case that happened lately, and now public, goes to prove this unfortunate fact:—A well known Scotch photographer, Mr. Macnab of Glasgow, having accumulated a large quantity of such residues in a dry chloride, paper ashes, &c., form wished to have it returned to the metallic state, and was naturally desirous he should get the full value of the metal which his collection represented, and being slightly imbued with the doubts before referred to, had a sample forwarded to a respectable London house, and was offered a return of two shillings per oz. for it, but having likewise sent a similar sample to a Glasgow refiner, he was surprised to hear from the latter party that he could have four shillings per oz. for it, or, in other words, he was offered £28 for it in London, he received £55 for it in Glasgow.

It is worthy of notice that the dry chloride gave a yield of within a fraction of 70 per cent., and the paper ash clear of carbon gave 71 per cent. The purity of the resultant metal may be judged from the fact that it was only some four pennyweights in the twelve ounces inferior to virgin silver. Then the charge was trifling; for example, for reducing 20 oz. of chloride, giving a yield of 19 oz.; 16 pennyweights, only cost 9s. 6d., and for large quantities it became much cheaper in proportion.

Now, without insinuating that any house would willingly defraud their customers, surely there must be an immense difference in the methods taken for the recovery of the pure metal. The plan adopted by Mr. Macnab was a wise one, and shows that photographers should be very careful to have their silver properly tested before sending large quantities to be reduced, as thereby they may effect a considerable saving, the quantity reduced for Mr. Macnab by the refiner (Mr. Wm. Coghill, Maxwell Street, Glasgow), amounted to over £120 sterling. We can thus see that our wide-awake Yankee friend, with his liberal offer and supply of apparatus, could yet manage a handsome income for his trouble, and yet afford to give to his customers a larger return than his enterprising friend on this side of the water.

PHOTOGRAPHY IN THE COUNTY COURT.

JNO. LOUIS V. SCHNADHORST AND HEILBRONN.

On Monday last, the 23rd inst., at the Westminster County Court, a case of some importance to the profession was heard.

The plaintiff and his wife sat for "Cartes de Visite," on the 30th of May, and now sued for 3s. 6d. balance due for portraits he alleged the defendants had failed to deliver in due course.

The plaintiff said that he had been abroad and unable to present his claim earlier, and urged that the remaining portraits had not been sent.

Mr. Heilbronu proved that the photographs had been duly delivered (partly to plaintiff himself at their studio,

and the remainder at his residence), by witnesses now in court, and erased from their books accordingly.

His Honour said that the defendants had made out a clear case, and observed that it was not at all requisite to take a written receipt for the delivery of photographs.

Verdict for the defendants, with costs.

RESEARCHES ON POSITIVE PRINTING.

BY MM. DAVANNE AND GIRARD.

TONING.

WE divide the numerous toning processes practised up to the present time into four classes.

1st. The so-called *acid toning*: that is to say, due to the employment of commercial chloride of gold, to which most frequently a certain quantity of hydrochloric acid is added.

2nd. Toning with neutral chloride of gold, due to the employment of the double chlorides of gold and potassium or sodium, recommended by M. Fordos.

3rd. Toning with protoxide of gold, characterized by the employment of the double hyposulphite of gold and soda, known to photographers as *sel d'or* or *Gelis's salt*.

4th. Alkaline toning, due to the employment of chloride of gold, most frequently a double chloride to which salts possessing a slight reaction are added, such as the bicarbonate, acetate, phosphate, and borate of soda. Into this category also enter those tonings in which the employment of chloride of lime is recommended, which, acting upon the pure whites of the albumen by the chlorine it contains, operates from the point of view of true toning only by the excess of lime with which it is charged, and so furnishing an alkaline bath.

To explain the true nature of toning in all these cases, we must, for each of them, estimate the relative proportions of gold and silver taken up by the proof toned, and compare them with the quantity of silver contained in a proof not toned, but prepared under similar conditions. In each process, we must also consider the case where the toning takes place previous to the fixing, and that in which the toning takes place after fixing, and repeat such experiment twice, varying the time of exposure, so as to give faith only to concordant results.

But this is not all—for considering that the picture is, according to the theory we have established, composed both of metallic silver and argentic organic matter, a kind of *lake* obtained by a combination of albumen, starch, gelatine, &c., with silver, and similar in all respects to the real lakes formed by colouring matters in textile fabrics—we have made parallel experiments upon papers simply salted and unsized, which, after exposure, contained almost only silver, and upon papers simply albumenized and not salted, that is to say, containing almost only argentic organic matter. From the resulting sixty-four experiments, we now give the numerical results and conclusions.

Let us first describe the method we always adopted. In each case, four half-sheets were carefully prepared, sensitized, exposed, &c. At the moment of introducing them into the toning baths, each piece was divided into two, one-half only has been toned, the other has been kept without toning, and as a standard of comparison. (We had satisfied ourselves by previous experiments that each half-sheet contained the same quantity of silver, and that we could give absolute confidence to this comparative stage).

The proof being finished, we placed in a large platinum capsule, a sufficient quantity of pure nitre, which we gently heated to fusion, then with a pair of pinchers seizing each piece of paper rolled up, we slowly burned them over the bath of melted nitre, in such a manner, that the heat was strong enough to produce a ready combustion, and yet insufficient to allow us to fear a volatilization of the silver. The cold mass was taken up by water, filtered and washed upon the filter with diluted acetic acid, to remove the considerable quantities of alumina, iron, and lime which arising from the ashes of the paper, would have prevented the fusion of the precious metals. The filters washed and dried, were afterwards passed into the cupel, the buttons of metal weighed, quartered when they were toned proofs, and the ordinary method departed from in employing successively nitric acid at 22 and 32 degrees.

Let us now proceed to study the first case that presents itself in our classification; that of toning with acid chloride of gold. The numbers we have obtained in the sixteen experiments made, are given in the following table. As to the calculations

from which we have deduced our conclusions, they have been established in starting upon the fact that in employing chloride of gold, Au³ Cl³, the latter, in the act of substitution, must theoretically transform it into chloride, and consequently be placed in such a condition that the last fixing may cause the three equivalents of silver to disappear, according to the formula—

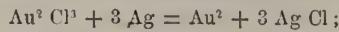

which, consequently,

$$\text{Au } 2 = 196$$

must replace

$$\text{Ag}^3 = 108 \times 3 = 324.$$

1ST.—TONING WITH ACID CHLORIDE OF GOLD.

TONING AFTER FIXING.

Proofs upon Paper simply Albumenized.

Time of Exposure.	Numerical Order.	Numerical Results.	Results of Experiments.
2 Hours.	No. 1. Portion not toned.	Ag 0.121	0 gr. 034 of gold equivalent to 0.056 of silver, the portion toned (No. 2) should contain 0.121 — 0.056 = 0.065 of this metal; but experiment gave 0.059; in this case we find the proportion of silver 0.006 deficit
	No. 2. Portion toned.	Ag 0.059 Au 0.034 Ag + Au 0.093	
15 Minutes.	No. 3. Portion not toned.	Ag 0.049	0 gr. 012 of gold equivalent to 0.019 of silver, the portion toned (No. 4) should contain 0.049 — 0.018 = 0.030 of this metal; but experiment has given 0.028; in this case, therefore, we find the proportion of silver 0.002 deficit.
	No. 4. Portion toned.	Ag 0.028 Au 0.012 Ag + Au 0.040	

Proofs upon Paper simply Salted.

2 Hours.	No. 5. Portion not toned.	Ag 0.236	0 gr. 062 of gold equivalent to 0.102 of silver the portion toned (No. 6) should contain 0.236 — 0.102 = 0.134 of this metal; but experiment gave 0.123; in this case, then, we find the proportion of silver 0.011 deficit.
	No. 6. Portion toned.	Ag 0.123 Au 0.062 Ag + Au 0.185	
15 Minutes.	No. 7. Portion not toned.	Ag 0.076	0 gr. 017 of gold equivalent to 0.044 (of silver, the portion toned (No. 8) should contain 0.076 — 0.044 = 0.032 of this metal; but experiment gave 0.026; in this case, then, we find the proportion of silver 0.006 deficit.
	No. 8. Portion toned.	Ag 0.026 Au 0.027 Ag + Au 0.053	

TONING BEFORE FIXING.

Proofs upon Paper simply Albumenized.

2 Hours.	No. 9. Portion not toned.	Ag 0.154	0 gr. 028 of gold equivalent to 0.046 of silver, the portion toned (No. 10) should contain 0.154 — 0.046 = 0.108 of this metal; but experiment gave 0.092; in this case, therefore, the proportion of silver is 0.016 deficit.
	No. 10. Portion toned.	Ag 0.092 Au 0.025 Ag + Au 0.120	
15 Minutes.	No. 11. Portion not toned.	Ag 0.068	0 gr. 014 of gold equivalent to 0.024 of silver, the portion toned (No. 12) should contain 0.068 — 0.024 = 0.044 of this metal; but experiment gave 0.037; in this case, then, we find the proportion of silver 0.007 deficit.
	No. 12. Portion toned.	Ag 0.037 Au 0.014 Ag + Au 0.051	

Proofs upon Paper simply Salted.

Time of Exposure	Numerical Order.	Numerical Results.	Results of Experiments.
2 Hours.	No. 13. Portion not toned.	Ag 0.304	0 gr. 065 of gold equivalent to 0.109 of silver, the toned portion (No. 14) should contain 0.304 — 0.109 = 0.195 of this metal; but experiment gave 0.176; in this case, then, we find the proportion of silver 0.019 deficit
	No. 12. Portion toned.	Ag 0.176 Au 0.065 Ag + Au 0.241	
15 Minutes.	No. 15. Portion not toned.	Ag 0.115	0 gr. 036 of gold equivalent to 0.059 of silver, the toned portion (No. 16) should contain 0.115 = 0.059 of this metal; but experiment gave 0.042; in this case, then, we find the proportion of silver 0.014 deficit.
	No. 16. Portion toned.	Ag 0.042 Au 0.036 Ag + Au 0.078	

Thus, in all the preceding cases, the substitution of gold for silver has evidently taken place in atomic conditions; this regular progress takes place upon argentic organic matter as well as upon silver, and both before and after toning, and after short as well as after long exposure. Nevertheless, as the conclusions contained in the last column show, experiment in all cases shows a slight deficiency of silver; this deficiency is very evidently due to the acidity of the liquid, to the presence of hydrochloric acid in the toning bath; this acid attacking (independently of all toning) a portion of the silver, converting it into chloride, which the fixing salt subsequently removes; this observation explains the well-known maxim;—acid toning baths redden the proofs.

This mode of toning is regular and quick; it gives slightly red tones, but which are not disagreeable; but the great danger it presents is shown by the following; it removes more silver than is required by theory, and it diminishes the intensity of the proof in proportions which the photographer has not always the power to check. Moreover, if we compare the experiments Nos. 8, 12, and 16, made after exposure of a quarter of an hour, with the experiments Nos. 6, 10, and 14, made after exposures of two hours, it appears that the deficit of silver is more sensible in the case of short exposure than in long; in a word, it appears that under the dissolving action of the hydrochloric acid the half-tones suffer more than the deep blacks.

In conclusion, we cannot recommend this toning process, as photography is now in possession of a more advantageous one; still, in cases where it may be employed, for special works, the operator must print a vigorous proof, in order to compensate for the loss of strength caused by the hydrochloric acid.—*Bulletin de la Société de Photographie.*

A FEW WORDS IN REGARD TO LIGHTING OPERATING ROOMS FOR PORTRAITURE.*

THERE is probably no one department of photographic manipulation so disregarded, neglected, or perhaps as little understood among Americans—in fact, it may be said of all photographers—as the proper lighting of operating rooms; one of the principal causes from which result the great majority of poor, worthless pictures, which we find in every community.

This defect in many establishments does not arise from careless indifference in regard to the character of work produced, for nearly all have a desire for success which will remunerate the expenditure of time and capital, aside from the gratification of an honourable pride of reputation, not only with patrons, but in the profession. Many operators, whose knowledge of chemical manipulation is sufficient to enable them to produce passable, or even good work, are so little acquainted with a few simple laws of nature in regard to light, that their productions are almost invariably unworthy the name of pictures.

* *The American Journal of Photography.*

Let us, as physicians would say, make out a diagnosis of a few cases, and then seek for the remedies with which to produce our cures. First, A wants a sky-light operating room, which he designs as follows; size of room, 18 by 24 feet; height of walls from floor, 10 feet; north pitch of roof, and number of degrees, between 10 and 45; sky-light, 8 by 10 feet flush with roof; lower edge of light 2 feet from intersection of wall and roof, and 3 feet from end of room, &c. A's case is hard, though not an uncommon one, and his productions are a constant—provided they do not fade—advertisement of his own ignorance. His "pictures" are patches of intense light and shadow, which make very good caricatures of those who favour him with their patronage. All the high lights are *very* perceptible, and all, or nearly all, in the shadow are quite *imperceptible*. The light upon the forehead and brows is relieved (?) by the midnight darkness which reigns beneath the brow, nose, and chin. The great artist Sol, or his assistant A, has evidently turned off an unfinished work. The half-tones, which add so much beauty, seem to have been entirely forgotten, or put in with such violent contrasts that their beauty is much like a light under a bushel.

A's sitters call his pictures "flat," "chalk and ink," "don't look them," and they resolve to patronise his neighbouring photographer B.

A sits down to cogitate—wonders what the matter can be. He thinks that some change in his chemicals may reduce the high lights, and bring out the shadows. Tries it: result—anything but brilliant. After great and manifold trials, gets the blues, becomes disgusted with the business, concludes that he was not made for a photographer, and sells out.

B built his operating room after A's model; but his patrons being a little more fastidious than A's, often found fault with the blackened eyes, and ugly spot under the nose and chin, which his picture represented.

B, being a little more shrewd than A, had, after trial, consultation and study, sought a remedy by introducing a small window into the side wall of his operating room. This window for economy's sake must be small, besides which he feared a large window might give *too much* light. After this improvement he hoped to succeed. He did *partially* succeed in getting rid of those "ugly black places," and began to hope that all was right.

Alas for human hope! His sitters again began to complain. This time some of their pictures looking "as though they were dead;" others, "the eyes look so badly," still others, "no eyes at all;" and occasionally some one would persist in trying to make poor B believe that one side of his face was *not* very dark, and the other, *very* light; and some wanted to know what "those two *white spots* in the eyes were for?"

One lady would indignantly remark that her picture made her look like the fat woman at Barnum's, and another that her picture looked like a hatchet; some were too old, and *few* too young.

B is in a quandary and asks for advice, which we humbly offer; advice founded upon the experience, failures, and successes of fifteen years' practice, resulting in the ability to produce what friends, and we trust a majority of patrons, unite in calling first-class work.

Axiom—No one ever did or ever can produce *good* pictures by a badly arranged light. Consequently, *never* use a room for your sittings in which you cannot get a *good* light. If you own a badly arranged room, remodel it, or build another. If you are a tenant, make your landlord do it for you, or take rooms of one who will give you this one feature which you must have—a good light.

My own experience leads me to prefer a light for portraiture arranged, as near as may be, upon the following plan. For copying, a different arrangement will be found preferable, which may be explained in future.

The light or window should be at least five or six feet from the end of the room nearest to the window, but the better plan is to have the light midway of the side wall of the room, thus giving better facility for working both ways, which is

necessary very often in all large establishments, or those who prize uniform good result.

The operating room should be at least ten feet high, the other dimensions may be such as the size of work, instruments, capital, &c., may require and admit of. A room fifteen by thirty feet will answer for all the ordinary sizes and styles; for large groups, more room might sometimes, though seldom, be required. The window for such a room should be about ten feet wide, introduced into the side wall, within not more than twelve inches of the operating room floor, reach from that point to the intersection of the wall with the roof, and from that point it may follow the angle of the roof a sufficient distance to bring a plumb line from the upper edge of the glass to the floor, at least two-thirds of the distance across the width of the room, measuring from the bottom of the window near the floor. If the roof is nearly flat, sufficient rain-shedding pitch may be given, by raising that side or edge which is farthest from the perpendicular portion, or a ridge may be introduced into that same part, which we will call the roof of the skylight. Such ridge should be as light as safety will allow, as also should be the rail or beam at the intersection of the wall and roof portion of the window. If the window faces towards the north, use plain white glass, unless the prospect is an unpleasant one, and you can afford sufficient loss of light to shut it out with ground glass. If your window faces south, east, or west, finely ground glass will be found preferable to the plain.

In either case, never omit having curtains or some other subduing agent arranged over your whole window, so as to give you perfect control over the light. A very effectual method of accomplishing this is found in an arrangement of wires and curtains across (*never* up and down), your window both side and top. The curtains should not be more than thirty or thirty-six inches wide, and should be so arranged as to overlap each other a few inches, as shingles or slate on a roof. The wires can be arranged by stretching them from blocks fastened at each side of the window, in such manner that the rings on the edges of the curtains will slide upon them without any difficulty. Never make your operating room look like the deck of a man-of-war by attaching cords and rigging to your window curtains; such arrangements often get out of repair, and require considerable nautical skill, which is not needed by landmen photographers. A light wooden rod is the most convenient article for changing the position of your curtains, and can be gotten up quite tasty enough for the most fastidious. Very good curtains can be made of light blue unglazed muslin, or cambric, or some similar material; and if you want still greater control over the light than these would give you, it can be obtained by using two sets of curtains, one of light material, the other of dark or heavy, thus enabling you to shut off all light from any part of the window which you may choose. Other arrangements there are, such as coloured glass or wooden shutters, but the writer has never found anything so convenient and effectual as properly arranged curtains.

NEW PROCESS OF ENGRAVING.

[The following account of a new process of engraving is worth the attention of all those of our readers who are interested in the general progress of the fine arts.]

We have been commissioned by Mr. E. Vial (an eminent chemist of Paris) to direct your attention, as a *connoisseur* in the fine arts, to an important invention which he has made in the art of engraving, which virtually places the graver in the hands of the artist himself, so that his own most subtle touches are at once faithfully engraved on a steel or other plate, preserving the individuality and real feeling of each artist in precisely the same degree as his own painting or drawing would do.

This process admits of the following variations:—

1. The artist may draw directly upon the steel plate in either crayons, or lithographic, or other ink, and the slightest touch, as well as the broadest lines, will be *instantaneously* engraved in intaglio.

2. The artist may draw in crayons, or in lithographic or other ink upon paper, and the drawings can be transferred to the steel plate and engraved instantaneously.

3. The artist may draw with chalk, ink, &c. upon zinc, and the drawing will be faithfully engraved in relief.

4. The most elaborate engraving or lithograph can be reproduced on a steel plate in from ten to thirty minutes from a *paper proof*, without injury to the original.

The process is also equally applicable—

1. To the instantaneous engraving of calico-printing, embossing, and other rollers, either from designs drawn on the metal or on paper, or from lace or other fabrics placed in contact therewith.

2. To the instantaneous engraving or damaskeening of arms, cutlery, &c.

3. To *photographic* or *heliographic* engraving on steel, and to various other useful purposes where rapid, faithful, and economical engraving is required.

The rapidity of the process is truly marvellous, and the net cost is merely nominal.

The process has been very favourably spoken of by the French press, and has been witnessed and approved of by the most eminent savants, artists, and others in France, amongst whom we may refer you to M. Dumas, senator, member of the Institute, &c.; Marshal Vaillant, Minister of Fine Arts; Count de Nieuwerkerke, Superintendent of Fine Arts and Director of the Imperial Museums; Messrs. Goupeil and Co., and Messrs. Hachette and Co. (publishers), &c. &c. The latter are working the invention *commercially* in France.

We shall be happy to give you further information, and to show you specimens of the remarkable results obtained, on your favouring us with a call at your convenience.—We are, Sir, your obedient servants,
DAVIES AND HUNT.

NEW PHOTOGEN FOR OBTAINING PORTRAITS AT NIGHT.

BY M. MC A. GAUDIN.

As winter approaches it becomes necessary to think of the means of obtaining portraits at any hour of the day or night, especially in those places where the light becomes very weak. I have already pointed out the means which succeeded with me in employing a firework composition.

For some time past I have made use of a small furnace, placed under the chimney of my room, with which to obtain very high temperatures. Being on the ground floor, the chimney has a draught of nearly 70 feet, and as all the air of the chimney must pass through my furnace, the activity of combustion is very great. To obtain the largest fire possible, instead of coke, which cakes together, I use the graphite of gas retorts, such as is employed in galvanic batteries. On the first day the bars of my grate were burned and melted, and on the second day the little bars of iron which replaced them shared the same fate: then I placed some large iron bars at the bottom, and had, it might be said, no grate, making the combustible itself serve instead; so that when my furnace is in full operation, its ash heap is the seat of a vivid combustion which splendidly illuminates the lower portion of my room.

It is this that gave me the idea of a photogen for obtaining portraits at night, by adding a stream of oxygen to the air drawn through the furnace. When fed by atmospheric air alone, the light given forth is equal to a hundred candles, but with the addition of oxygen, it attains to a thousand candles.

To establish a photogen of this kind, the closed chimney of a room on the ground floor must be put in communication by means of iron pipes, with the furnace placed opposite a reflector of elliptical curvature. The furnace will be composed of a grate of refractory clay placed upon a cast-iron cylinder in two compartments; the internal cylinder serving for the passage of the flame and the enveloping cylinder being the reservoir of the oxygen gas which passes in through twenty small holes of one-tenth of an inch in diameter in front of the furnace. The grate will be protected by a lump of fire-clay, leaving at the side the oxygen enters a circular opening of four inches in diameter, by which the air of the apartment can flow in upon the combustible by the draught of the chimney, drawing with it the oxygen gas which escapes from the reservoir without velocity.

To obtain the oxygen without employing a gasometer, we place above the fire, in the grate, a cast-iron pot half filled with

chlorate of potassa mixed with its weight of oxide of manganese. This pot has a pipe connecting with a reservoir of oxygen by a flexible tube, and when it is exhausted of its gas it can be replaced by another.

From the operation of this apparatus there will result a very dazzling photogenic light proceeding from the illumination which will be at its maximum on the surface of the coal arranged dome-wise upon the clay grate, and receiving a reverberation from the cover. If the grate happens to melt, we must interpose between it and the coal some small flints, such as are found naturally rounded in the diluvium.

The cast iron pots for making the oxygen gas in, have a rim, and contain about three gallons. This production of oxygen gas is unattended by any danger, the pulverized manganese is intended to moderate the action of the liberation of the oxygen gas from the chlorate of potassa, which becomes very furious towards the end, because the chlorate first passes into the state of per-chlorate, and in the end this per-chlorate is decomposed with violence if the fire is not kept down. In the present arrangement the fireplace being distant, its effect is always regular, and the disengagement of oxygen is regulated by passing through a large number of large holes, and the last effervescence in the iron pot cannot take place except through a prodigious increase in the intensity of the furnace.

The fire is first lighted with charcoal, and the fuel is stirred from time to time, to throw down the ashes formed in small quantity upon the graphitic carbon in full ignition.

With such a photogen, giving the light of a thousand candles, the floor and walls of the room around the reflector being covered with light-blue calico, portraits may be obtained at night as quickly as in an ordinary glass room during the day.—*La Lumière*.

Proceedings of Societies.

NORTH LONDON PHOTOGRAPHIC ASSOCIATION.

THE usual monthly meeting was held in Myddelton Hall on the evening of Wednesday, the 18th inst., Mr. G. SHADBOLT in the chair.

The minutes of a former meeting were read and confirmed.

Mr. W. WARWICK KING read a paper on the Tannin Process, (see p. 566), and exhibited a number of fine negatives and prints.

Mr. SEELEY asked Mr. King if he ever was troubled with pinholes in tannin plates.

Mr. KING had met with them occasionally, but attributed them solely to dust.

Mr. SEELEY was disposed to attribute them to the accumulation of iodide of silver in the bath, as it was worst with the last of a large batch of plates.

Mr. King had used a bath for many plates in succession without meeting with spots except such as he could trace to dust.

A conversation on the keeping qualities of tannin plates followed, in the course of which,

Mr. G. CARTLAND, jun., of Eton, said that the Rev. Mr. Carter Brown gave him two stereo tannin plates last Christmas, and he did not expose them until a week ago, when they yielded good negatives.

Mr. SHAVE had kept Fothergill plates 12 months, and then got good pictures. He asked Mr. King if he got as much detail in foliage with tannin as with Fothergill.

Mr. KING thought quite. In answer to another question, he said he kept the plate in the nitrate bath five minutes.

After some desultory conversation on the influence of temperature, the use of citric and acetic acids,

The CHAIRMAN said that a very low temperature was always detrimental to chemical action, and scarcely sufficient attention was paid to this in development. It should be borne in mind however, that if a high temperature were used, and acetic acid employed at the same time, a larger quantity would be necessary owing to the evaporation. He asked Mr. King how long after exposure he had kept the plate before development.

Mr. KING: Not more than a fortnight.

Mr. SEELEY could not keep them after exposure more than two days, and the longer they were kept the worse was the negative. It was weak, foggy, stained, and poor when the plate was kept.

The CHAIRMAN said that, in working the honey process, he

remembered that whilst plates were fresh they were perfect; in a short time a reaction was set up which gave irregular results, but after a longer time keeping the reaction was complete and and the picture was clean, but required longer exposure.

Mr. KING had found no difference from one day to fourteen. He was keeping some now for a longer time to try them.*

Mr. SEELEY said that, unexposed, they would keep indefinitely.

Mr. HILL thought that bad keeping was due to the presence of free nitrate.

The CHAIRMAN thought that where keeping caused irregular development, it was owing to development having set up spontaneously.

Mr. SEELEY used gelatine as a preliminary coating.

Mr. KING used no preliminary coating.

The CHAIRMAN thought that this might possibly account for the discrepant experience, as the gelatine itself might form a compound with the nitrate of silver sensitive to light.

Mr. SIMPSON remarked that all organic compounds of silver were liable to spontaneous decomposition.

A conversation followed, in which some doubt prevailed as to whether Major Russell said that gelatine plates would keep well, if prepared in quantities ready for use. Mr. Simpson remarking that both views were right. Major Russell said that plates prepared with simple gelatine did not keep well, but if the gelatine were iodized they kept better.

A conversation followed on the appearance of the image before development, which Mr. King always expected to find if the exposure were correct.

Mr. SEELEY said he always regarded it as a sign of over-exposure. He never found it, except when a bromide was used as well as an iodide. Mr. King's exposures were very much longer than he had ever given. He would himself give, with a view lens of 11 inches focus and $\frac{3}{8}$ ths stop, three minutes in a good light.

Mr. KING had never worked so quick, nor did he think that an under-exposed plate would give a good negative with any dodging in development. An over-exposed might be preserved with care in developing.

The CHAIRMAN observed that Major Russell was far too close an observer, and too careful to give instructions for having an under-exposed picture in development, without sound reasons for his conviction that this was possible.

Mr. HILL said he did not believe it was possible to over-expose a dry plate. He had exposed a picture twice without the slightest injury.

Several members said that over-exposure would give a weak sky.

The CHAIRMAN related a curious experience in exposing a plate twice, tending to show that light could undo what it had done.

After some further conversation, Mr. G. DAWSON said he thought much of the uncertainty which existed in relation to the tannin process arose from photographers being ignorant of the materials with which they were working. They frequently took any collodion that came to hand, and although Major Russell had said the collodion did not matter much, in his experience it was very important, and he found that many otherwise good collodions would not answer for that process, and others which might be used required preliminary coatings on the plate. He had found that for pyroxyline a modification of Hardwich's formula gave the best results. The formula which after one trial he found gave the best results was as follows:—

Sulphuric acid (commercial oil of vitriol)			
sp. gr. 1.840 by measure	36 ounces
Nitric acid sp. gr. 1.450	12 "
Water	8 "
Best cotton	800 grains

The cotton was immersed at a temperature of 155 Fahr. This would yield 1,000 grains of pyroxyline, and by its yielding this weight, he tested its exact suitability for the purpose. The collodion was then made as follows:

Ether sp. gr. 725	4 drachms
Alcohol sp. gr. 805 to 810	4 "
Pyroxyline	5½ grains
Iodide of cadmium	1½ "
" ammonium	1½ "
Bromide of cadmium	2 "

With this collodion he could work on plates 14 inches square without any substratum or preliminary coating. He coated and excited in the usual way, using then a 10 or 15 grain tannin solution, and he had absolute certainty in the results. Before developing he ran an edge of Sohnee varnish round the plate for about the eighth of an inch, and lost no films. In dry collodion he thought that certainty was of more importance than rapidity; and this process was not very rapid,—not so rapid as some of Major Russell's results. He found some uncertainty with the process Major Russell had recently recommended. Using the same collodion with no iodide but 7 or 8 grains of bromide of cadmium, exciting in a 60-grain bath for 10 minutes, draining five minutes before washing; then well wash; then immerse in salt and water; then wash again in common water; then apply a 10-grain tannin solution, and finally wash again with distilled water, and dry. With these he found indications of great sensitiveness, but a great tendency to fog, perhaps only one plate in six yielding a good negative. He developed with carbonate of ammonia and pyrogallic acid, as directed in Major Russell's book. Major Russell himself thought very highly of this method, and in his hands it gave beautiful results; but in his (Mr. Dawson's), he had only obtained one or two at all presentable pictures, although it was very rapid. He thought many failures were due to imperfect washing; they could not wash too much, and an ill-washed tannin plate was less sensitive than a well-washed plate. The use of a bromide was very important; one grain to the ounce gave a great improvement upon none; two grains an improvement upon that; and three grains seemed to cause a falling off again. He agreed with Mr. King on the importance of removing complications and securing simplicity.

The CHAIRMAN thought Mr. Dawson scarcely understood Major Russell as to the use of any kind of collodion.

Mr. DAWSON said it was probable that with almost any collodion a picture could be obtained; but it was impossible with some samples to avoid crapy lines, and with others to prevent the film splitting from the glass.

A conversation on certainty followed, in which Mr. King said that as a rule he could take out a dozen plates and bring home a dozen negatives.

Mr. COLLIS exhibited some interiors of the Crystal Palace, by Messrs. Negretti and Zambra, sent by Mr. Ross as the work of his No. 2 triple lens. Mr. Collis was unable to state precise particulars as to equivalent focus or aperture used. This gave rise to a conversation in which the chairman expressed an earnest hope that makers would in future be induced to speak of the true equivalent foci of their lenses, and of the apertures by definite measure instead of by numbers which explained nothing.

Mr. GREENWOOD asked if Messrs. Negretti and Zambra were photographers. He believed not; and he thought it only fair, therefore, on the principle of honour to whom honour is due, that the artist's name should have been mentioned.

Mr. SIMPSON said it was a very common circumstance, perhaps sometimes to be regretted, that the real producer of a thing was unknown, the employer alone appearing before the world as the producer. This was especially the case with the photographic operator; but the case before them was not an unusual one. Messrs. Negretti and Zambra had the sole right to photograph within the Crystal Palace, and doubtless these were by one of their operators, and in accordance with common custom the pictures appeared as their work.

Mr. GREENWOOD said that was the point of which he complained. He believed these were by a namesake of the gentleman (Mr. Collis) who exhibited them. He thought that the system pursued by the Stereoscopic Company to Mr. England, of publishing his name with his productions should be more fully carried out.

Mr. COLLIS thought it was the general custom which could not well be avoided, that an employer should obtain the credit of what was produced by those in his service.

The CHAIRMAN said there was no motion before them, and he did not think it would be prudent for them as a society to pass any resolution on such a subject.

* Since the meeting, Mr. King has favoured us with a sight of one of these, a negative developed five weeks after exposure, which, with the exception of slight under-exposure, is clean and satisfactory. From Mr. Seeley's description of very short exposures, it appears probable that they may, in some measure, account for the results attributed to imperfect keeping.—Ed.

Mr. SIMPSON said he thought it would scarcely be necessary. He felt convinced that employers might without any derogation frequently allow their operators to share the credit of production, and a hint from the society deriving its force rather from the acclamation with which the remarks on the subject had been received, than from a formal resolution, would doubtless have the desired effect.

Mr. HART exhibited some specimens printed on different baths, one on a 70-grain nitrate bath, one on a 20-grain nitrate bath, and one on a 20-grain nitrate bath with 50 grains of nitrate of soda. There was very little perceptible difference in the results. By daylight, that with the nitrate of soda was blackest in tone, that with 70 grains of nitrate most purple in tone, and that with 20 grains of nitrate of silver only the brownest. There was little difference in depth or intensity; but the 70-grain bath gave the greatest sensitiveness.

Mr. HOWE exhibited a series of fine photographic transparencies of various kinds, by the aid of the magic lantern and oxyhydrogen light, which were much admired.

Mr. J. COLLIS was elected a member, and the proceedings terminated.

Correspondence.

TRANSFERRING NEGATIVES TO GUTTA-PERCHA.

DEAR SIR,—I have seen several letters in the NEWS lately on the subject of Gutta-Percha Transfers, and am surprised that the process is not more generally adopted. There is no difficulty in the operation, but what a careful manipulator would easily overcome, and the only objection is the smell of the benzole during the operation of coating the negative or positive on the glass, as this must be done in a room where there is a fire, it being necessary to set the gutta-percha by heat, otherwise it will dry opaque. In the first volume of the NEWS, page 203, I gave a very simple method of transferring collodion films to paper. The gutta-percha solution should be made with the very thin pink gutta-percha, torn into strips, and put into a bottle; the bottle should be more than filled with the gutta-percha, and the benzole poured on to it. It should then be placed near a fire with the cork loose. When all the gutta-percha is dissolved, and the liquid cool, the cork should be tightly fitted and the bottle put away till the solution is clear, when it should be poured into another bottle bearing the sediment. If left for some time, it will become a perfectly white mass, but is easily dissolved by placing the bottle in hot water. I find negatives print quite as well as when on the glass, and the film can be kept in a book between blotting paper with perfect safety. I have numbers that have been kept for years. Now that transparent stereoscopic slides are mounted with ground glass it would be a great saving in weight, risk of breakage, and expense, if the films were taken off the glass and put on to paper, and then mounted on a skeleton mount to keep them rigid. Gummed or gelatinized paper might be sold for the purpose. There is no fear of the film not coming clean off the glass, if the gutta-percha solution be thick enough and the glass placed in water for a minute or two.—I remain, dear sir, yours very truly,

THOMAS BARRETT.

Mead Vale, Red Hill, 19th November, 1863.

QUI CAPIT, ILLE FACIT.

DAR SIR,—In reply to a letter, signed B. L. Phillips, I claim the privilege of saying—

That, as I never saw, knowingly, backgrounds produced by this writer, I could have had no intention of injuring his, or, indeed, any other person's business; that when I use the word portraitists, I mean neither this, nor that, nor the other, but simply portraitists, and that when Mr. Phillips fails to understand what he reads, it is just possible that it may be due to something besides a want in the writer.

I have the audacity to differ from this person on more points than that of colour *versus* neutral tints in photo-

graphic background. For instance, I do not believe that a week's practice with the camera teaches you pictorial, perspective, and chiaroscuro; and I certainly *do* believe that in a photographic journal it is as legitimate to advocate the artistic as the scientific aspects of the *art-science* represented.

If the mere mention of a rival tradesman, unassociated with either praise or blame, so rouses the indignation of Mr. Phillips, what will his rivals say when they find him so modestly asserting that his own method of painting in "colours or tints" gives such very superior and "charming effects," and that his own productions prove it? Fie!

In conclusion, allow me most distinctly to state that I am *not* "a disappointed rival; and that the remainder of Mr. Phillips' letter being *contra bonos mores*, I have nothing to say thereto.—I am, dear sir, yours truly,

R. A. S.

PHOTOGRAPHIC LENSES AND DISTORTION.

SIR,—The modern photographic lens is a great triumph of optical art and science; and though it cannot yet be considered as having arrived at perfection, it reflects the highest credit on the skill of those who have bestowed so much pains and talent in satisfying the many requirements that the wants of photography have necessitated. As these lenses have had so much to do to please all parties, it seems hard to attribute to them defects to which they are not liable; and, with your permission, I will say a few words in their defence. They are charged with distortion. Now, I at once admit this defect so far as to acknowledge that, in the marginal parts of the field of view, lenses have this defect more or less according to their quality. Let this be termed *angular distortion*, and I admit its existence, inasmuch as the angles subtended at the eye by different portions of the object, are not, throughout the whole of the field of view, proportional to the angles subtended at the eye by corresponding portions of the image formed by the lens upon the focussing-glass, and, therefore, of the photographic picture formed by its means. This angular distortion does not exist, in the case of a good lens, in the central portion of the picture, but is generally palpable in its marginal parts; for example, when an animal is taken as large as the lens will admit, its extremities, if allowed to occupy the margin of the picture, will be out of proportion to the parts in actual situation.

But it is also said that a lens distorts those objects which are not situated in the same plane, perpendicular to the axis of the instrument; for instance, in taking a portrait, the hand is placed too far in front of the body, or if the foot be advanced again beyond this, and, as a natural consequence, the hand appears in the picture too large for the body, and the foot still more out of proportion, this apparent disproportion is said to be due to the imperfection of the lens in magnifying the nearer objects, and thereby distorting the picture.

This, however, is not a true explanation of the fact, that nearer objects do appear out of proportion to those more remote. The lens would act very imperfectly if it did not exhibit the nearer hand larger, *i. e.*, subtending a larger angle at the eye than the other, for this is the case with the eye itself. The nearer hand subtends at the eye a larger angle than that more remote and larger in exactly the same proportion as is apparent in the picture drawn by the lens placed at the same distance from the object. In the case just supposed, the hand would occupy the centre of the picture, or nearly so, and therefore there would be no angular distortion. To explain the apparent disproportion, the foot would be further from the centre, and therefore might be in some degree affected by angular distortion, which would make it appear in the pictures larger than would be due to its mere linear distance from the lens. In a picture, every object is mechanically drawn by a lens in the same proportion as its image, which is formed on the retina of the eye, the lens of the eye portray-

ing nearer objects on the retina magnified, so to speak, in the same proportion as those objects are represented on the focussing screen of the camera, allowing for angular distortion, if any, with which I am not now concerned, and which is owing to the picture being formed on a plane instead of a spherical surface, and also to the axes of oblique eccentric rays or pencils of light emerging from the lens or combination of lenses in directions not parallel to those of the incident rays, but diverging outwards. In the case of pencils of light emanating from objects at different linear distances from the lens, it is assumed that when diverging on to the lens from the same axis, they will emerge from it, and converge to force on the same axis, whether parallel or not, an assumption which, whether accurately true or not, is sufficiently so for the correctness of my reasoning.

Admitting then the fact of this apparent distortion, what is the explanation? Several considerations concur in this, but the principal one is that the picture is drawn upon a plain surface, and has not the relief necessary to convey to the eye that impression of difference of distance of the various objects which in vision is taken into account by the wonderful and mysterious organ of sight. In other words, the picture has not a stereoscopic affect.

A gentleman who lately gave a lecture upon Photography, among other recommendations, some pertinent and some the reverse, advised that in portraiture the features should be in the same place, perpendicular to the axis of the lens, lest this distorting trick of this reduced instrument should exhibit the suffering subject with a swelled chin or a hyper-intellectual forehead, not apparently being aware that the lens would represent the features, however placed, in the same proportion as they are subtended at the eye, and that the proper remedy in such cases would be an infusion into the picture of such an amount of light and shade as would secure as far as possible the relief requisite to obviate this inartistic distortion.

The naked outline of objects, *e.g.*, boxes, or chairs, drawn in exact perspective appear out of proportion until they are clothed with light and shade, and invested with the appearance of solidity; and it is to his skill in giving proper relief to his figures, as well as in the avoidance of all excess in attitude, that the artist must look for the concealment of this apparent distortion, and not to improvement in his lens which is indeed quite guiltless in the matter.—Yours truly
M. A.

IN SELF-DEFENCE.

SIR,—The seemingly angry reply addressed by Mr. Phillips against "R. A. S." (whose inoffensive remarks on backgrounds I thoroughly endorse, as being *very* similar to those I have myself made), contains an ungenerous statement, calculated, if not intended, to damage an important branch of my business.

The cloths I paint for the floor in connection with backgrounds, do not, by being attached to the latter, render a fresh cloth necessary for every background, as Mr. Phillips asserts, except when backgrounds of an entirely different character are made use of.

Possessing an intense horror of squabbles arising out of trade jealousies, I only ask you to insert this simple statement as something due to those who are dependent upon my business for their support.—Yours truly,
A. H. WALL.

6, Dartmouth Park Road, N. W., Nov. 23rd, 1863.

PHOTOGRAPHY IN COLOURS.

SIR,—Having read with great interest what you occasionally published with regard to photography in colours, and many times thought about the chances we have to see the art brought to that desired pitch of perfection, the article from *Galvani* makes me wish to say something about the subject.

The invention of those two gentlemen in Italy does certainly not look like a step in advance, as they only substitute painting certain parts of the picture over with chloride of gold to painting them over with colours, and I am afraid the latter process is decidedly the better one.

In my opinion the problem of photography in colours is, for the present, to be solved by the chemist, not by the photographer; for, to do the work, there is wanted neither more nor less than a chemical which, by a tolerably short exposure, turns white in white light, black in the dark, green in green, yellow in yellow light, &c., and the colours of which can be easily and instantaneously fixed.

Whether such a chemical exists among the infinite number of chemical compounds that occur or may be produced in the animal, vegetable, and mineral kingdoms, is a question to which we may almost confidently answer, no.

It is true we see, for instance, on the surface of plants and leaves, a chemical which turns *green* in *white* light, but even if we were able by analysis exactly to determine the compound, and produce it, there would be nothing gained. The beautiful green colour soon disappears when the organism of the plant no longer supplies fresh matter; and besides, the circumstance that it turns green in white light would make it useless.

Still, people who like to make experiments, spend skill, money, and time, in searching after the wished for art of photographing in colours, may not, after all, find all their endeavours wasted; but, like the alchemists of old, make many valuable discoveries in searching after something that is unattainable.—I remain, sir, yours truly,

AUGUST BUSCH.

Photographic Notes and Queries.

STORMY WEATHER AND PHOTOGRAPHY.

DEAR SIR,—We have just passed through a succession of terrific gales; those gales affect photographers in other ways than that of smashing their glass cases, and stopping work, &c., more especially those who live near the coast, and possibly for many miles inland. The air in those hurricanes is saturated with saline particles, as any one by tasting the glass on the outside of his window can testify; and after the rain which almost invariably follows a cessation of the storm, this salt is carried by it into tanks and other reservoirs, rendering it almost unfit for washing purposes, and operating most disastrously in the first washing of prints, converting the nitrate of silver into such irregular patches, as no after-washing can eradicate. No doubt most photographers are perfectly aware of this, and use distilled water in their first washings; if not, the refreshing of our memories can be of no harm.—Truly yours,

CORNISH CHOUGH.

Talk in the Studio.

CARD ALMANAC FOR 1864.—Mr. H. B. Pritchard has designed and photographed a very clever card almanac for the coming year which will form an interesting and useful addition to photographic albums. The centre of the card is occupied by the almanac, which is arranged in a very simple tabular form. Around it, grouped with considerable taste and skill, are the title pages of about half a hundred periodicals, comprising the chief representatives of the daily, weekly, and monthly press. Photography takes a prominent place, and is represented on the card by the PHOTOGRAPHIC NEWS. The card is as perfectly photographed as it is well designed, and will, we doubt not, have the large circulation it deserves.

OBITUARY.—Mr. Fitz, of New York, one of the earliest American photographers, and one of the ablest opticians of the States, died on the 31st. ult., after a brief illness. Our readers will remember allusions in the letter of our American Correspondent to an improved Globe lens he had recently constructed.

THE ALLEGED EARLY PHOTOGRAPHS.—The history of the supposed pre-Daguerreotype photographs has excited considerable attention from the general public, and good articles on the

subject have appeared in the *Saturday Review*, the *Illustrated News* and other papers. Great stress appears to be laid by the writers in the general press on the fact that the paper pictures contain no trace of silver, as though that were a remarkable fact in connection with photography. A correspondent of the *Glasgow Herald* noticing this, calls attention to Mr. Mercer's pictures, obtained with the salts of iron, which he thinks are almost unknown to photographers. Mr. Mercer has perhaps scarcely given his experiments the publicity to which they are entitled, but well-informed photographers are familiar with his labours. The absence of salts of silver is of course no argument in the subject of photography, as, besides the various iron processes, there are those in which carbon has been largely used, and also the salts of uranium, &c.

MATTHEW BOULTON'S CAMERA.—We have received from Mr. Kirkby a description of the missing camera referred to by Mr. Smith in his history of the early photographs. Our correspondent saw the camera some years ago in the hands of Mr. Powell, and gives us a detailed description and drawing of it, which will appear in our next.

To Correspondents.

- I. M. L.**—Side light is very important in taking card pictures; nevertheless, with a top light in the position of No. 2, and fifteen feet wide, it would be possible, with skilful arrangement, to get good results. We prefer the design of No. 2, but would like some side light as well. See article on "Card Pictures" in our last.
- G. P. H.**—The paper to which you refer owes its offensive smell to some peculiarity in the preparation. You cannot do anything to alter it that we know of. It gives good results we believe, but is certainly unpleasant to use. 2. It is not necessary to use distilled water for the hypo bath. The time of immersion with the strength you use, one part in five, should, with thin soft paper, be about 10 minutes; with stout hard paper, twice that time. 3. Prints may be properly toned in any time, from 5 minutes to an hour, depending on the strength of the gold bath and other conditions.
- CAMERA.**—We should place the optician's name in much the same order as you have done, 1, 2, 3.
- T. C.**—It is contemplated by the Photographic Society to open an exhibition early in the coming year; but when or where is uncertain, as a suitable place has not yet been found. 2. The purple tint in a toning bath is due to the reduction of metallic gold in a very finely subdivided form, probably produced by the heat you apply. 3. It is impossible to state how much sulphide of potassium will be required to precipitate the silver from a given quantity of hypo solution, inasmuch as it is impossible to state how much silver is present. You can only ascertain by testing. Take a portion of the supernatant liquid in a test tube or small phial, and add a little solution of sulphide of potassium to it; if a precipitate fall, there is still silver; if not, take another portion, and add a little nitrate of silver to it; if a precipitate fall, it indicates excess of the sulphide solution. 4. Your chloride may become dirty and discoloured from many causes. Wash it well to remove all impurities.
- A. W. B.**—Amongst the makers your name, decidedly No. 2 in our opinion. 2. It is not necessary to remove the stopper from the bottle previous to sunning the bath.
- EXPOSURE.**—It is a little uncertain to what lens Dr. Kemp refers in the passage you mention. In another place he refers by name to Dallmeyer's new stereo lens (double); but here it seems probable that he refers to an ordinary single stereo lens of 5 or 6 inches focus.
- PHOTO ENGRAVER.**—The cause of the defects in your negatives, both stains and cracks, appears to be imperfect washing after fixing. The fixing salt, probably hypo, has remained largely in the film, subsequently crystallizing out, and causing spots, stains, and cracks. They have the effect of too much top light, and are not sharp. The lens does not seem suitable for card pictures standing figures. 2. The No. 1 B is not so rapid, nor does it cover so well as No. 2 B, but is an excellent lens; it will, under ordinary circumstances, cover a 5 by 4 plate. It answers very well for copying. We cannot state any precise time of exposure, as that must vary with circumstances. 3. So far as our experience goes, collodion No. 4, in your list. 4. The only mode available of securing portraits at night is by the aid of Moule's Photogen. 5. A side light is desirable, but a top light, managed as we described in the first article last week, will do. A west side light will present no difficulty except in the afternoon, and then must be stopped out with blinds.
- J. GILBERT.**—The last edition of "Hardwich's Manual" is, we understand, out of print. There is a rumour of a new edition in course of preparation, but we have seen no authoritative announcement. If we meet with a copy we will let you know. 2. We cannot tell you the name of the largest manufacturer of protosulphate of iron. We believe there is a very large manufactory at Walker, near Newcastle-on-Tyne.
- FELIX.**—We never met with a faded Daguerreotype. If exposed to the atmosphere or impure gases, the surface becomes tarnished, and the picture almost invisible. To remedy this make, a moderately strong solution of cyanide of potassium—say 30 grains to the ounce. Wet the surface of the Daguerreotype first with water, holding it under a tap until the water flows all over without greasy marks. Then pour on the cyanide solution, which will quickly remove the tarnish. Watch carefully, so as to stop the action before the image is attacked; rinse well, finally, with distilled water, and dry, by applying the flame of a spirit lamp to the back of the plate, and blowing gently at the surface.
- F. VINCENT.**—The use of gelatine or gum tragacanth will aid in giving vigour to your developed prints—the exact proportions must be matter for experiment. The solution, which must also contain the salting preparation, may be brushed on or floated. Increasing the proportion of chloride, and decreasing the proportion of bromide, will also tend to increased brilliancy.

P. C. J.—The kind of fog to which you refer, as appearing to exist between the film and the glass, may arise from several causes. Dirty glasses are the most common cause, and some samples of glass will cause it, no matter how carefully cleaned they may be. Cold and damp weather tend to produce it, when other causes are there. Under-exposure, and forcing the development, will produce, if the slightest tendency exist in the glass. A thin-bodied collodion materially aids in producing it. When you see the tendency, use a thick-bodied collodion, well cleaned, good glasses quite dry when coated, full exposure, and plenty of acetic acid in the developer. A few drops of tincture of iodine to each ounce of collodion is often an advantage in such cases.

J. MOONEY.—See our advertisement columns. We cannot recommend any especial house. Prices will be easily obtained from any house.

TANTRIS PLATES, Bristol.—We cannot make out the signature of this correspondent. The best picture is No. 3; with a little more brilliancy it would have been a good picture. Nos. 1 and 4 are very unsatisfactorily lighted, there is possibly from the cause you name; they look very like the result of an uneven film of collodion. We have seen them, however, when the film was perfectly even, and are uncertain of their cause. With care in choosing your time when your subjects were well lighted, you would get better pictures with the same plates. 2. Mr. Williams uses a silver bath containing from 30 to 50 grains with a weakly salted paper; 80 grains with ordinary commercial papers. The ordinary acetate bath, containing 30 grains of acetate of soda to 1 grain of chloride of gold. Immerse in fixing bath for 15 minutes.

A LADY MEMBER.—We shall have something more to say on the Exchange Club in a week or two. We could scarcely undertake the invidious duty of deciding the classification of prints for exchange, as no one would be satisfied. The dissatisfaction of many members with the position assigned to their prints by the referees has been one of the difficulties of the late system. We shall have pleasure in assisting you by such classification; but we should hesitate to undertake that duty generally. 2. The dull surface to which you refer is probably caused by using water, which forms insoluble salts of silver apparent chiefly on the edge to which the drawings run. The use of distilled water would, in such case, be a remedy. We are quite uncertain what collodion suitable for the purpose you can obtain in Glasgow. When the prepared albumen shows signs of decomposition it is not safe to use it.

THOMAS DAVIES.—You are under no necessity of registering your pictures, or sending them to Stationers' Hall or elsewhere. Registration is a privilege to protect you from piracy, as, without registration, you cannot prevent your pictures being copied. Registration will not prevent another person from taking another view of the same subject, only from copying yours. It must be a negative from one of your prints to be a piracy. 2. The extent to which you may use water is a matter entirely governed by the arrangements of the water company, and may vary with each one. Additional charge is generally made for water to photographers. 3. We should prefer to have the north light as a side light.

A. A.—The only formula we can give you for copying oil paintings is the general advice to use a freely bromized collodion, and give plenty of exposure. Also avoid a light which causes the "handing," or impasting, of the painting to cast numerous small shadows.

J. H. S.—Either of the lenses you name are good; but, if you can conveniently afford it, by all means have No. 2. It is worth all the difference in rapidity, depth, and definition.

ONE ANXIOUS TO LEARN.—Your diagram is not very clear, but if we understand you aright, your sitter cannot receive much north light, if a building projecting above your glass room is placed at six yards distance to the north. If the east end be quite open and unobstructed, place your back-ground to the south, so that the side light reaches your sitter from the east.

PETER GRIFFITHS.—The only secret lies in having the prints well rolled, then lighting properly. Diffused light answers best; any direct light will make the surface cast shadows and show its texture. The diffused light of a room is best.

E. C. L.—Your request for "information on the electric" light is somewhat indefinite. There is no specific work on the subject, but a great deal of information has appeared in our pages from time to time, as to its application to photographic purposes.

A. H.—Your name will be duly proposed.

AUGUST BESCH.—The weather has been very unsuitable for trying collodion. From a trial we did make we think the collodion very excellent. We received Mr. Lobb's charming picture and noticed it, but he did not mention your name. Its excellence indicated that all the chemicals employed were good, in good condition, and skilfully used.

M. A.—The note to your letter was probably just; but was better suppressed. We prefer to avoid giving pain, without it is necessary to secure some good end.

J. FOOTE, ALPHA, A. S. WATSON, E. S., W. RUTHERFORD, FRANK W. GOOD, and J. SHERRER.—Received, and shall have attention.

W. NOTMAN.—The box received, and the enclosures forwarded. Notice shortly.

C. W.—To what extent you are bound by the agreement we cannot tell you. That is a question for a lawyer. As to the payment of your fare, common sense dictates he should hand you the amount, and not, by purchasing a ticket, compel you to go by a certain train.

R. HUNT.—We are requested to inform this correspondent that the charge for insertion 13 times would be 120 francs. Several Correspondents in our next.

Several important articles in type are compelled to stand over.

Photographs Registered During the Past Week.

- MR. SAMUEL BROOKES**, 93, Widemarsh Street, Hereford,
A Drawing in Pencil and Sepia of Hereford Cathedral.
- MR. PETER BERGESS**, 13, Market Place, Macclesfield,
Photograph of Samuel Higgenbotham, Esq.
- MESSERS. MOONEY AND DUNNE**, 2, Cork Hill, Dublin,
Photograph from a Lithograph of Hogau's Statue of Thomas Davis.
- MR. ABRAHAM WIVELL**, 16, Islington, Birmingham,
Two Photographs of Shakespeare from a Painting.

THE PHOTOGRAPHIC NEWS.

Vol. VII, No. 274.—December 4, 1863.

CONTENTS.

	PAGE	PAGE	
The Tannin Process; Is it Slow or Rapid	577	Description of a Self-acting Washing-Cradle, &c. By Cornelius Hanbury, Jun., F.C.S., &c.	582
The Tannin Process.—Short Exposure. By H. C. Jennings, Jun.	577	Proceedings of Societies—London Photographic Society—American Photographic Society.....	535
Notes on the Tannin Process. By G. W. O.	577	Correspondence—Foreign Science—Reduction of Residues by London Refiners—Matthew Bolton's Camera.....	586
On Iodide of Silver as a Sensitizing Agent, &c. By A. Poitevin	578	Talk in the Studio	587
Photographic Chemicals	579	To Correspondents	588
Jottings from the Note-Book of a Photographer's Assistant. No. VII.	580	Photographs Registered during the past Week	588
On Toning Paper Positives. By C. Ommeganck	581		

THE TANNIN PROCESS; IS IT SLOW OR RAPID?

VERY considerable difference of opinion seems to exist as to the degree of sensitiveness possessed by tannin plates and the amount of exposure they require. Mr. King's exposures, described in our last, are regarded by many as excessively slow. As discrepancies of experience on such subject often depend on minor points of manipulation, we here give the details of practice of two gentlemen who have obtained good results with comparatively short exposures.

THE TANNIN PROCESS.—SHORT EXPOSURES.

BY H. C. JENNINGS, JUN.

As an admirer of Major Russell's beautiful tannin process, I was somewhat surprised to hear of the long exposures given by Mr. King. I work rather large plates, $\frac{1}{2}$ size nearly, lens No. 1 triple, quarter-inch stop; for a brick building with dark foreground, I gave three minutes on Friday, November 13th, at 8 o'clock in the morning, day rather dull. Certainly my lens is shorter focus.* But still I do not think that it accounts for the vast difference in the exposure Mr. King has been giving and mine.

My method is not new; I have chiefly obtained it from the PHOTOGRAPHIC NEWS, yet it may be of interest to some of your numerous readers:—

1st. Clean plates very thoroughly and coat them with any good collodion working well with iron development (I prefer Rouch's bromo-cadmium collodion) sensitized in the same bath as for wet negatives for about three minutes, drain the plate well, and,

2nd. Place in a dish of distilled water and rock about for half a minute, proceed with another plate, and,

3rd. Wash thoroughly under the tap, swirl the face with distilled water, drain slightly, and,

4th. Coat twice with

Tannin, pure	5 grains.
Distilled water	1 oz.

Pour off into an empty bottle and place the plate on a levelling stand, and pour on gently enough tannin solution to cover the face; let it remain on whilst another plate is being washed. When the second plate is ready, pour off the tannin from the first (it may be used over again), let drain, and place to dry in any convenient place free from dust.

To develop, varnish the edges with lac varnish, moisten the film under the tap, and pour on the surface a 10 grain solution of pyro in distilled water. Let the detail come well out, then pour off the pyro solution into a glass, and add one, two, or three drops of the following silver solution, according to the size of plate:—

Silver	10 grains
Citric acid	20 grains
Water distilled	1 oz.

Let it intensify as much as possible; if over-exposed, add more silver, but cautiously, or the negative will be apt to give an abominable "soot and whitewash" print. If there is reason to believe the picture under-done, use the pyro without silver, rather warm, and it will in most cases make up for the deficiency in the exposure.

But no true photographer will tolerate *under-exposure*. It is far better to give at once the full exposure than to risk getting foggy or stained negatives by after doctoring. I generally fix with cyanide; but hypo might perhaps preserve the density better. Enclosed is the print of the house mentioned in the first part of my letter. It is by no means perfect, but is sufficient to prove what can be done with a little perseverance in this beautiful and simple process.

In conclusion, I may state that I use the tannin solution used for the first two coatings over again, adding a grain or so tannin to each ounce.

[The print enclosed by our correspondent is amply exposed, clean, and full of detail.—Ed.]

NOTES ON THE TANNIN PROCESS.

BY G. W. O.

LIVING on the outskirts of Dartmoor, and no brother amateur—I believe no professional photographer residing within at least twelve miles of this village—I have to work out by myself the causes of my successes and failures. The arrival, therefore, of your paper is always looked forward to with interest on a Saturday morning; to it I am much indebted for valuable information, and in hopes of adding a mite to aid workers in the tannin process, I send the way in which I proceed. During this past year I have not lost a view from a faulty dry plate; the few failures that I have had were caused by trying to take such views as "a flood during a storm of hail or rain," when the failure has been from a want of light. I have not tried any of the quick dry processes, as the keeping qualities of the plate seem to be in an "inverse ratio" to the rapidity. My dry plates, during the early part of the year, were exposed five minutes (this was the time through the whole of July); the last I took was on 26th of October, and was exposed fifteen minutes. All of these were rather over-exposed; they were developed without any addition, on account of under-exposure. For stereoscopic plates I use a pair of Ross's lenses, for half-plates one of Grubb's. All my chemicals (except hypo and tannin) are from Ponting, at Bristol, so that they can be relied upon. As many of my views on and about the Moor require long walks, I do not like to run the chance of the film washing off, and therefore always coat with gelatine. The trouble is little, and regret at the disappearance of a view that has cost some hours' walking to obtain, is great. To the gelatine I now add the iodide and bromide of cadmium, as Major Russell advises, and my negatives are now nearly as transparent, and print as quickly, as my iron negatives. To save the trouble of referring to the work, I put the quantities at

* The triple of 8 inches focus, $\frac{1}{2}$ inch stop, and the applanatic of 12 inches focus, $\frac{1}{4}$ inch stop, have nearly equal relation between aperture and focus.

foot. The collodion that I use is Ponting's iodized; this I keep for several months, and mix with it, in a separate bottle, the bottoms from the bromo-iodized that I use for the instantaneous work, so that no collodion is wasted. After removing the plate from a 30-grain nitrate bath, made according to directions on the bottles of Ponting's iodized collodion, I place it in a flat dish nearly filled with rain water, and having passed the hook of a little stick under it, keep lifting the plate up and down gently until all the greasy marks have disappeared. I then leave the plate, pour the collodion on another glass, and place it in the nitrate bath, and then I return to the plate left in the rain water. This I again move about with the hook to see if any lines exist, and if they do not, I transfer it to dish "No. 2," also filled with rain water, where I again move it about for a minute, then, by the hook, draw the end of the glass over the edge of the dish, and (having blotting-paper between the first finger and thumb of my left hand and the glass) lift it by the corners on to the pneumatic holder. Having let the water drain for a few seconds, I pour on the tannin so as to run in a gentle stream into the same beaker from the end near myself to the corner from which the collodion drained. I pour the next tannin on four times from beaker "No. 1," which carries away any water, and then the same number of times from "No. 2." (As the tannin in "No. 1" gets wasted I add from "No. 2," always putting the fresh mixture in "No. 2.") Having let the super-abundant tannin run off, I leave the plate to dry in a box kept on purpose, and then return to the plate in the bath (about five minutes having elapsed since it was put in), and proceed in the same manner. I put fresh water in the first dish after every fourth, and in the second after every sixth plate.

The preservative solution that I use is in the proportion:—

Tannic acid	15 grains
Distilled water	1 ounce
Methylated spirit	$\frac{1}{2}$ drachm

The developers, pyrogallie acid, nitrate of silver, and citric acid, as recommended by Major Russell in his first edition, keeping one stock bottle of the pyrogallie acid and alcohol, and another of nitrate of silver, 20 grains to the ounce. At foot I put the quantities of these developers.

The plates prepared as above I have kept more than six months, and they were apparently quite as good then as when freshly made. Not wishing to waste plates, I have not tried the shortest time of exposure that they would require, but I think that instead of five minutes, as before mentioned, a good picture might be got in three and a half or four, but as the over-exposure is easily remedied in the developing, and as I put on gelatine to save the trouble of doing the work again, for the same reason I prefer a little over-exposure to a weak or ruined plate. I develop as soon as possible, but have kept the negative a week, and it was then quite sharp and bright. Mr. King's process, as described in his paper printed in the PHOTOGRAPHIC NEWS of 27th November, differs for the most part from mine in manipulation, with two exceptions, *i. e.*, he does not use a gelatine coating, which I do; and he uses new bromo-cadmium iodized collodion, and I use old, simply iodized collodion, for the quantity of bromo-iodized from the bottoms of bottles is but trifling. With respect to the washing, we both agree as to the moving, but do it in different ways, and I think that mine is the least troublesome. We both use the same proportions of tannin, but Mr. King does not use the same portion twice, which I do. In developing, I lay the plate in a dish of common pump water, and let it stay there for four or five minutes; there is no danger of the gelatinized film coming off, or swelling, or cracking, it will bear a deal of rough usage. The levelling stand I never use. In developing, we use the same chemicals, but rather differently. If there are signs of over-exposure (which show themselves directly the developer is poured on) I pour back

the developer into the beaker, and add a few drops of the nitrate of silver and citric acid mixture which corrects the evil. If there are signs of under-exposure, I pour back and add some more drops of the pyrogallie.

Like Mr. King, I do not "hope to communicate any novelty," and a person conversant with Hardwich and Major Russell's works will find much of the above therein. A photographer who has succeeded in one way of working had better persevere in that, although another may appear easier; but to beginners who have not settled into one plan of working, practical suggestions are of the greatest use; following, therefore, Mr. King's good example, I send you the above notes of my way of proceeding, hoping that they may be acceptable.

Gelatine Solution.

Nelson's gelatine	40 grains
Glacial acetic acid	40 minims
Distilled water	8 ounces
Iodide of cadmium	3 grains
Bromide of cadmium	3 "
Small piece of iodine				

The three last to be dissolved first in a few drops of water, and then added—

Developers.

No. 1. Pyrogallie acid	72 grains
Alcohol (absolute)	1 ounce.
No. 2. Nitrate of silver	20 grains
Citric acid	20 "
This quantity reduced in cold weather.				
Distilled water	1 ounce.

For use, diluted No. 1.

No. 1. Developer	10 minims
Distilled water	1 ounce.

For developing a stereoscopic plate, to 3 drachms of diluted No. 1, add from 10 to 20 minims of developer No. 2.

[It will be seen that the exposures of G. W. O. are longer than those of Mr. Jennings; whether this be due to the latter using more bromide, or to the difference in the lenses, we cannot say.—Ed.]

ON IODIDE OF SILVER AS A SENSITIZING AGENT, AND ESPECIALLY OF THE ACTION OF TANNIN, AND SOME OF THE OXIDIZABLE SUBSTANCES, IN PHOTOGRAPHY.

BY A. PORTEVIN.

THE action of light upon iodide of silver is of three kinds, according to the condition of that body and of the substances it is associated with.

1st. It is *nil* upon chemically pure iodide, isolated from every substance which retains the iodine light tends to separate.

2nd. It modifies the iodide when metallic silver, nitrate of silver, and other soluble salts of this metal are present, and imparts to it the property of exciting the reduction of the acidulated solutions of silver by known developers, sulphate of protoxide of iron, gallic or pyrogallie acid, and also by mercurial vapours; and it is this action that is turned to account to obtain negatives in the camera.

3rd. It brings the iodide to the state of inert iodide under the action of the developers, or when acted upon by light, it is covered with a solution of alkaline iodide. This action is the same with regard to metallic silver, which induces the belief that sensitized iodide of silver is brought partially to the metallic state when it has lost a certain portion of iodine to form a sub-iodide. These well known facts apply to the other insoluble compounds of silver, and particularly to the chloride, bromide, &c.

Starting from this point, and wishing to explain the part played by the principal bodies which, up to the present

time, have been associated with iodide of silver upon the sensitive film, I first prepared a film of inert iodide, that is to say, rendered inert by an excess of alkaline iodide and exposure to light; then I carefully washed it. In this state the iodide of silver is wholly unacted upon by the developing solutions, even after a long exposure, but if the smallest quantity of a soluble salt of silver be added—the nitrate, for example—it becomes sensitive and proper to receive a latent image in the camera. I had no occasion to verify this fact, it is familiar to every photographer, but I submitted to experiment acetic acid, the gums, albumen, gelatine, sugar, honey, solutions of resins in alcohol, spirits of turpentine, and certain bodies, such as salicine, alloxantine, &c. None of the substances rendered iodide of silver sensitive to light. But it was not so when I employed tannin, suggested by Major Russell: this body communicates to insensible iodide of silver, that is to say, completely free from nitrate of silver, a sensibility at least equal to that obtained from nitrate of silver itself. Tannin is therefore a *sensitizer*, and it must be regarded as such and not as a *preserver*, as all the substances are termed which are employed to preserve the sensibility of plates, or rather to prevent them from fogging completely in presence of developers in developing the negative picture.

We might have anticipated this property in tannin, since in the method that succeeds the best for preparing dry collodion for the tannin process, we entirely obliterate the nitrate of silver which covers the plates, by the final washing in water, recommended by the author of the process; in fact, this water containing alkaline carbonates and chlorides renders insoluble the last traces of free nitrate of silver on the surface of the plate; it is, moreover, by remarking this fact that I have been led to make the present task.

I thought that other very oxidizable bodies might possess the same properties as tannin, but I have experimented only with those I had at hand, and recognized that the solutions of sulphate of protoxide of iron, gallic and pyrogallie acids act like tannin. We shall, I am certain, discover others, which, alone or mixed, will prove more powerful sensitizers, perhaps, than the soluble salts of silver or tannin, which are the only ones employed hitherto. Perhaps new sensitizers will permit them to replace iodide of silver by other insoluble salts of this metal, and every thing leads to the belief that already bromide of silver employed alone, appears, under the influence of tannin, to be more sensitive than the iodide, at least, according to the statement of Major Russell.

I have wished to turn to practical account this purely theoretical but well-established fact—the sensibility communicated by tannin to iodide of silver—to avoid, if possible, all the causes of failure met with in the production of negatives, such as spots, fogging, insensible films, &c.—accidents which usually proceed from other reactions than that of light upon the sensitive iodide of silver, for they are due to the impurity of the materials, which give to the iodide of silver the property of exciting the reduction of the developing solutions. This modification takes place at the moment of the preparation of the sensitive film of iodide; or, rather, during the time, more or less long, which elapses between its preparation and exposure in the camera, and mostly during the development of the latent picture.

The method I propose is applicable to all known processes, whether we operate with waxed paper, albumen, gelatine, or wet collodion or dry: moreover, the actual and special purity of the materials, paper, collodion, and nitrate baths, will not be absolutely indispensable. This method has, it is true, been pointed out and adopted in part, but not from the same point of view—that is to say, the complete suppression of nitrate of silver as the final sensitizer of the iodide of silver.

The following is my method, in which I shall speak only of the employment of iodized collodion, having employed no other. I prepare this collodion in the usual way, adding $1\frac{1}{2}$ per cent. of iodide to it—coating a plate, and sensitizing it in a nitrate of silver of bath, strength 8 to 10 per cent.

For example, I wash the coating of iodide of silver, formed in order to remove the greater portion of the nitrate covering it; and what will probably surprise many operators is, that it is not necessary to perform this operation in the dark room.

The plate being freely washed, I cover it with a solution of iodide of potassium (about 4 of iodide to 100 of water), this solution being previously saturated with iodide of silver by the addition of a few drops of the solution of nitrate to the bottle containing it: moreover, this solution of iodide of potassium will serve until exhausted; and it is not necessary to make a bath, as it is sufficient to pour it again and again upon the film of iodide of silver and back into the bottle. I perform this operation in full daylight. And it is very essential to expose the surface thus treated to light for at least a few minutes. The object of this treatment is to destroy all germs of spots or fogging which come out during the final development.

I next wash the plate in plenty of water, to remove as much as possible the alkaline iodide, which has performed its task, and I then have a film of iodide of silver wholly insensible to light, and incapable of exciting the reduction of the developing solutions. To render the plate sensitive, it suffices to pour on its surface, in the dark room, the aqueous solution of tannin of 5 per cent. strength, it is then quite ready for exposure in the camera, and it is also as sensitive as a plate sensitized by nitrate of silver.

To cause the latent picture to appear, I wash the plate to remove the excess of tannin, then I pour upon the exposed surface a solution of aceto-nitrate of silver, of the strength of 2 or 3 per cent., and then the developer, sulphate of iron or pyrogallie acid. The development takes place precisely as in the usual methods, but what is no less remarkable than advantageous is, that we thus obtain with certainty, and without very great precautions, very clear negatives, vigorous and without spots.

Instead of employing immediately the film sensitized by tannin, it can be reserved for the dry process, as it will keep a much longer time than if the nitrate of silver remained on its surface. We can also prepare in advance plates with inert iodide of silver, leaving them to dry, and sensitizing them by the aqueous solution of tannin, or what in this case is preferable, its alcoholic solution; all these methods, I repeat, will give excellent results.

I give here one method only; all I can say is, that this method, which may be applied to all known processes, requires much less care, and particularly, chemicals less pure with respect to their special and chemical condition, than is required in the ordinary processes, in which nitrate of silver enters wholly, or in part only, into the sensibility of iodide of silver.—*Le Moniteur de la Photographie*.

PHOTOGRAPHIC CHEMICALS:

THEIR MANUFACTURE, ADULTERATION, AND ANALYSIS.

CADMIUM SALTS (*continued*).—By far the most valuable compounds which this metal forms are those with chlorine, bromine, and iodine. Chloride of cadmium is best formed from the metal itself. As metallic cadmium is of great use in preparing these valuable photographic chemicals, it will be found convenient to keep it in the granulated form. To obtain it thus, take some of the metal and melt it in a clay crucible, either at a gentle heat in a fire, or, preferably, over a gas furnace. In the latter case it will be found advisable to conduct a stream of coal gas into the upper part of the crucible by means of a glass tube, and place the cover loosely on. The gas which escapes at the edge may be ignited. The object of this is to protect the surface of the melted metal from contact with the atmosphere, which would oxidize it, causing waste. When thoroughly melted, have ready a tall jug full of distilled water, then seize the crucible tightly with a pair of tongs, and pour the melted metal in a thin stream from a height of about two feet, into the water. The cadmium will form a very bulky granulated

mass: it must be quickly drained on a cloth, dried by artificial heat, and preserved for future use in a dry, well-stoppered bottle.

To prepare the chloride, take a convenient quantity of this granulated metal, place it in a glass flask, and pour over it pure concentrated hydrochloric acid, diluted with its own bulk of water. Action commences immediately, and it may be continued by the aid of gentle heat. When the cadmium is perfectly dissolved, evaporate the solution, if necessary, and allow it to cool. Chloride of cadmium will separate in the form of hydrated rectangular four-sided prisms. These effloresce in dry air, and lose their water when heated, becoming converted into the anhydrous chloride. This compound readily fuses, and, after cooling, has the appearance of a transparent mass of a metallic pearly lustre, and lamellated texture. At about a red heat it volatilizes, and may be obtained by sublimation in transparent micaceous crystals. When the fused or sublimed salt is exposed to the air, it loses its transparency and lustre, and crumbles to a white powder. Chloride of cadmium contains 38.73 per cent. of chlorine, when in the anhydrous state; it is easily soluble in water, but only slightly so in alcohol and ether. It is, however, sufficiently soluble to communicate marked properties to iodized or iodo-bromized collodion.

Bromide of Cadmium, from its solubility in alcohol and ether is largely used in photography. When dry, cadmium is added to bromine, no apparent action takes place, as the film of bromide of cadmium first formed on the metal is insoluble in bromine, and protects the cadmium from further action of this liquid. If water be added so as to dissolve the bromide, as it is formed, the metal is rapidly attacked, and a solution of bromide of cadmium is the result. Upon evaporation and subsequent cooling, the salt separates in the form of white efflorescent needles having the composition of

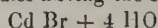

When heated to the boiling point of water, two of these atoms of water go off, and the other two are expelled at a temperature of 200° C. The crystals assuming an enamel-like appearance, but not fusing. When suddenly heated, the hydrated crystals fuse in the water of crystallization, and are rapidly converted into the anhydrous bromide. This latter compound may be also formed by the action of vapour of bromine upon the metal, at a heat approaching redness. The bromide being volatile at this temperature, sublimes as soon as it is formed; and leaves a clean surface of metal to the further action of the bromine. The sublimed bromide of cadmium occurs in white rounded laminae, having a mother-of-pearl lustre. It dissolves without decomposition in hydrochloric and acetic acid, but is decomposed by hot nitric acid. Water, alcohol, and ether dissolve it readily. The anhydrous salt 58.34 per cent. of bromine.

Iodide of Cadmium is one of the easiest salts to prepare. Place some granulated cadmium at the bottom of a flask and cover it with water; now apply gentle heat, and add iodine. Rapid combination will take place between the two; the iodine will be quickly decolorized, and must be replaced by fresh quantities of the same element until all, or nearly all, the cadmium is dissolved. Towards the end of the operation, the iodide of cadmium may crystallize out: this had better be prevented by warming the liquid, or by adding more water. Filter the solution if necessary, evaporate, and allow it to cool. Unlike the bromide and chloride of cadmium, iodide of cadmium does not unite with water in the act of crystallizing. It fuses very easily, and when crystallized, either from the fused state or from an aqueous or alcoholic solution, it separates in large transparent and colourless six-sided tables, permanent in the air, and having a brilliant lustre resembling mother-of-pearl. The crystals dissolve readily in water, alcohol, or ether, and is deposited unchanged from these solvents on evaporation. Iodide of cadmium contains 69.23 per cent. of iodine.

The chloride, bromide, and iodide of cadmium, unite with ammoniacal salts, forming compounds which are not without interest. Chloride of cadmium dissolved in water and mixed

with an equal atom of chloride of ammonium yields, when concentrated, silvery needles containing one atom of water; these, however, gradually disappear, and are replaced by large anhydrous rhombohedrons, which are soluble in water, and slightly so in alcohol; their composition is Cd Cl , $\text{NH}_3 \text{Cl}$.

When ammonia is added to a solution of chloride of cadmium, a white precipitate is produced, which dissolves on the application of heat, and is deposited in the form of a crystalline powder in cooling. When dried and heated, one atom of ammonia goes off. The composition of the precipitate is NH_3 , Cd Cl .

When a strong solution of bromide of cadmium is saturated with ammonia, it yields, on evaporation, small crystals, which have a composition of NH_3 , Cd Br . When rapidly cooled, the compound separates in crystalline grains, and when slowly cooled, in regular octohedrons.

A similar compound is formed by the action of ammonia on iodide of cadmium; the composition being NH_3 , Cd I .

Chloride of cadmium dissolved in water and mixed with an equivalent quantity of chloride of potassium, unites with it to form a double salt, having the composition Cd Cl , KCl . It is slightly soluble in alcohol, more so in water.

A similar compound is formed when equal atoms of bromide of cadmium and bromide of potassium are dissolved in water and evaporated together. The double salt separates in the form of hydrated needles, very easily soluble in water and slightly soluble in alcohol.

When equal atoms of iodide of cadmium and iodide of potassium are dissolved in water and the solution evaporated, a double salt of the two is deposited. According to Crofts, this is not crystallizable, but is very easily soluble in water, and slightly so in alcohol. With soda salts cadmium forms similar compounds.

It is very probable that some of these double iodides, bromides, and chlorides, might be of considerable use in photography. At first it was considered that so long as photographers got the right amount of iodine or bromine in collodion, it did not matter what was the base with which the metalloid was accompanied; but later observations and experiments showed that this was not the case. It is true that the base has no direct action on the photographic properties of the sensitive silver salt, but it has a very strong indirect action by its power of modifying the collodion and pyroxyline. Almost every base has been found to have a peculiarity in this respect; and it is advisable, therefore, for experimentalists to press into service all the new compounds they can meet with, in the hope of obtaining some which possess the greatest number of advantages, with a minimum of drawbacks.

JOTTINGS FROM THE NOTE-BOOK OF A PHOTOGRAPHER'S ASSISTANT.

No. VII.

PHOTOGRAPHY, like a sensation play or novel, is a source of continual excitement to all who are within range of its influence; there is such a constant changing about that the votaries of this fascinating art must of necessity be ever on the alert if they would keep pace with its gigantic strides of progression. These changes, which ultimately assume the position of fashion, are led by some bold spirits that fearlessly strike into new tracks. The public follows fashion, and the more timid photographer must look alive and run with the public if he has a desire to keep his shop open. Happily he has but few trade secrets to contend against, therefore success will assuredly be his if he perseveringly seeks it.

We sympathize with the many who are striving to impart to their pictures those fashionable dark tones that are obtained from an adoption of what is called lime toning, and who, from numerous failures, are tempted to believe that success is derived from some secret source that is omitted

in all written instructions; to those we would say, feel assured there is no concealment. Failures are produced by a non-observance of some indispensable conditions, to produce those tones so temptingly described in the pages of the PHOTOGRAPHIC NEWS, it is absolutely necessary the prints be produced from a really good negative, clear in the shadows and perfect in all its details. The paper employed should not be too highly salted, and we are convinced that under all circumstances, the richest tones will be secured by an adoption of the nitrate of soda bath for sensitizing chiefly on account of the bright red colour it produces when the paper is exposed to light. When associated with lime, the gold precipitated on a dead surface assumes a hue anything but agreeable to an educated eye; but with a warmly tinted foundation, the deposit acts as a subduing glaze through which the colour beneath penetrates, imparting that richness that forms the chief characteristic of properly managed lime toning.

In attempting to produce black tones with the old alkaline solutions (so called), an unpleasing inkiness generally presents itself, though with less exposure to their action, a colour is imparted to the prints, which, before fixing, appears everything that can be wished for, but one moment's contact with the hypo, and the promising hue is vanished for ever, simply because this fugitive colour is imparted by chlorine in its secondary formed union with silver reduced by the action of light, a substance that is soluble in the fixing solution. The combination last alluded to has given birth to an error that is entertained even among high authorities, because a certain portion of silver is displaced from the paper's surface, during ordinary toning operations it is considered that such a result must necessarily ensue in order that the gold may take up its abode on the ground rendered tenantless by the ejected silver, and that toning action can only proceed under those conditions. To prove the fallacy of this mode of reasoning, it is only necessary to give our method of toning a trial when it will be found that with the absence of free chlorine, bleaching influence is removed, and in spite of a liberal allowance of acid roaming at large in the solution, tones can be secured that will pass unscathed through the ordeal to which they are subjected during the process of fixing, MM. Davanne and Girard notwithstanding. To secure the above described results, we proceed to construct our toning solution as follows:—A stock bottle containing 8 grains carbonate of soda to the ounce of water, is laid aside in a convenient corner; on the same spot lies another bottle, in which is placed a saturated solution of chloride and carbonate of lime, allowing the excess of both substances to remain precipitated in the bottles; when ready for toning operations, we add to each grain of gold 10 minims of the soda solution, and on this mixture is poured a small quantity of boiling water to drive chlorine in a direction where it is unable to practise its mischievous tricks. So soon as the yellowness disappears, the mixture is thrown into the toning dish, and the necessary quantity of solution is made up with pure water, allowing about a quart to the grain of gold, from two to three drops to the last named quantity of the lime is then filtered into the dish, and we are ready for work. The solution may be used continually instead of fresh water each time, and during cold weather double the portion of gold above named may be added with advantage. It is best to tone all the batch of prints at one time: like Parkinson's formula, it moves slowly, and therefore cannot injure by causing untuned spots, if the prints are kept turned.

A bath thus prepared is decidedly acid, although from the quantity of water used, the particles are so widely separated by dilution, their presence remains undetected by ordinary tests; but if its acidity is doubled, it is only necessary to test the solution in a more concentrated form; indeed, without a liberal allowance of acid, the bath refuses to work, and from this fact we are able to judge the necessary quantity of the alkaline agent to be applied, and non-toning when the proper allowance of gold is present, usually means

too much soda. Printing must be carried no further than required in the finished picture, as it strengthens rather than bleaches in the solution we have described; and in toning the same conditions must be observed, as the colour imparted does not change in the fixing bath. Before fixing, the prints should be first passed through a water containing a small quantity of carbonate of soda, another liberal allowance of washing, and fix in the usual manner.

The part played by lime in toning would be difficult to decide. One thing is certain, where that substance is employed, if the excess of chlorine is first driven off by heat, the small quantity remaining makes no attack on the silver, as it does in the absence of lime, and the same results follow when an ordinarily prepared lime bath has got rid of its chlorine by long keeping. From these facts we are inclined to believe that the small quantity of chlorine liberated is absorbed by the lime ere it reaches the surface of the paper, hence the colour is imparted by the gold alone, which substance protects the print from further reduction when exposed to the fixing action.

And now, in conclusion, we would just observe that no royal road to photography exists. In offering formulas or directions, we do not promise invariable success to anyone, but to all who will master the principles we have done our best to lay down. We promise the ability to overcome difficulties which may present themselves. In our experience we find in printing operations materials for continual study. Every day brings to light some new difficulty, whose character can only be detected by close observation, and whose dangerous tendencies can be conquered only by means that are based on scientific principles.

In concluding our first series of "Jottings," we would just observe that, from motives of fair play, we have refrained from recommending the materials supplied by any dealer; but should the cause of failures arise from defective paper, we are willing to supply the name of our favourite maker, by directing, under cover to us, to the office of the PHOTOGRAPHIC NEWS, with a stamped envelope for a reply.

ON TONING PAPER POSITIVES.

BY C. OMMEGANCK.

ALTHOUGH the auro-cupric bath we lately recommended has given results superior to those obtained by every other preparation, we shall, notwithstanding, give some indications respecting two other very useful formulæ, because a great many photographers, having acquired a certain experience of these two formulæ, determine not to abandon them.

The two formulæ in question are, 1st, that of acetate of soda, and, 2nd, that of hypochlorite of lime.

Gold Bath with Acetate of Soda.

Water	...	1 litre	...	35½ fl. ozs.
Acetate of soda	20 to 30 grammes	300 to 464	grains.	
Chloride of gold	...	1 gramme	...	15½ grains.

The acetate mentioned above is the crystallized acetate ($C^2 H^6 O^3, N a O + 6 HO$)=139: it contains, as may be seen, six equivalents of water: we can employ with advantage the anhydrous acetate of soda (twice fused), first in its water of crystallization, and afterwards submitted to an igneous fusion; it has the same formula as the preceding, minus the six equivalents of water ($6 H O$): the sum of the constituent equivalents, or its total equivalent, is 85. Between these two salts the relation is therefore as 139 is to 85, or, in round numbers, as 3 is to 2; therefore 30 grammes of crystallized are equivalent to 20 of fused anhydrous.

Commercial crystallized acetate of soda is slightly alkaline; the fused acetate is ordinarily very strongly so.

The preparation is made by dissolving in the water first the acetate and then the chloride of gold. Decoloration takes place slowly, and the bath is not fit for use until the morrow, and sometimes even four or five days after the pre-

paration, according to the state of the atmosphere, the nature of the paper, the neutrality of the nitrate bath, and also the more or less alkaline state of the acetate of soda. This bath usually disengages a very strong odour of acetic acid, and gives an acid reaction with litmus paper; it transforms into acetate of silver the traces of nitrate still remaining in the paper at the moment of immersing the proofs; acetate of silver is quickly sulphurized by contact with the hyposulphite.

The proofs at the moment of being taken out of the toning bath, have an odour of acetic acid: they really are acid; when immersed in this state in the bath of hyposulphite of soda, they assume a beautiful black tone; but they are exposed to an energetic sulphurisation, and subject to rapid deterioration. By washing them in abundance of water before fixing, we can, up to a certain point, palliate this evil. A washing in water containing a minimum quantity of carbonate of soda, neutralizes, it is true, the free sulphuric acid, but may cause many other inconveniences, among others that of causing blisters upon removing the albumen from the surface of the paper.

The addition of carbonate of soda to the gold bath, prescribed by some, will be the best remedy; but its practical effect, according to our experience, is to render the acetate entirely superfluous. The partial substitution of phosphate of soda for one portion of the acetate of the same base, for example, 15 grammes of the one to 15 grammes of the other, gave very good results; but in our eyes it presents the objection of uselessly complicating the formulæ, and of augmenting, without motive, the collection of photographic chemicals.

Bath of Gold and Hypochlorite of Lime.

Water	4 litres	...	141 fl. ounces
Carbonate of lime	...	10	grammes	...	154 grains
Hypochlorite of lime	...	1½	"	...	23 "
Chlorite of gold	...	1	"	...	15 ⁴ / ₁₀ "

Preparation. Put the carbonate and hypochlorite of lime into a mortar, and add sufficient water to form a creamy paste, then add the chloride of gold, and triturate together until an intimate mixture is effected, then leave it to repose for a quarter of an hour to an hour, according to the surrounding temperature, or as the quality of the paper is more or less subject to a corrosive action in the gold bath; then it is stirred into a litre of water, and the solid portion is allowed to deposit; it is then filtered, and the other three litres of water are added; this is when it is required for immediate use; when it is proposed to keep it for some days before using it, the quantity of water is diminished one half, the other proportion remaining the same. If a considerable time elapses, it may be that the bath will not tone at all; but the addition of 2 or 3 drops of the 10 per cent. solution of chloride of gold will render it active.

On removal from the gold bath, the proofs must be washed in two waters, or in one only, if very abundant. This bath is the most economical we know of, as to composition, be it understood, but not always as to use, it requires many precautions for the good preservation of the proof, which must be printed very strong, without which the half-tones will be lost.

Without washing the proof previous to immersion in the hypo bath, it causes sulphurization, produces sulphide of silver, and a disengagement of sulphurous gas, &c., and proofs that will not remain permanent.

It is often complained that toned proofs turn brown in the hyposulphite, without the tone returning after the solution of the salts of silver. Various causes may lead to this much dreaded result.

However, they all end in a too superficial toning. The following are the principal circumstances under which they may be produced.

Paper that has been nitrated a very long time—proofs kept a long time before being toned—paper moist at the time of printing—paper become slowly humid by exposure

to the atmosphere between printing and toning—silver bath too weak or too strong in nitrate of soda or ammonia, in consequence of long use—paper dried too slowly after contact with the silver bath or left to dry spontaneously in winter. The paper must be dried in less than an hour, and by artificial heat if necessary, interposition of humid paper or flannel behind the positive paper during the printing, and, lastly, and most frequently, a bath too poor in gold, too much reduced by fear of corroding the proofs.

It may sometimes happen that we are afflicted with paper of bad quality, from the remnants of dealers' stock, or bad manufacture. Paper deteriorates with age, and even in a very short time if not kept in a very dry place.

In winter, the toning must take place in a very warm room, beside a fire. The operation may be advantageously performed upon a water bath, kept at a temperature of 68° to 77° F.

We shall add some advice for those who have found that our formula for the auro-cupric bath has a corrosive action upon the paper they make use of.

First, the bath may be prepared several hours in advance. In winter, the prepared bath may be put into a bottle, which is placed in a large jar or other convenient vessel containing water heated to 104° F., and left it in from half an hour to an hour, without, however, applying a source of heat to maintain the temperature at 104°.

We shall conclude by some very curious remarks upon the peculiarities encountered in the colouring of the paper.

Albumenized paper contracts a different hue, both in printing and in toning, according as the negative has been developed with iron or with pyrogallic acid; and, if developed with iron, if it has been intensified to a blue-black by a salt of mercury—if the printing has been performed in the sunshine or in the shade—and if the sun has sensibly warmed the negative or not—if the negative is varnished with white varnish or with brown, when the difference in the colour of the negative is not even evident to the eye—if the glass upon which the negative is taken is blue, yellow, green, or violet—if, being of the same composition, it is thick or thin—lastly, if the sensitive paper exposed to the sun is in repose, or put into rapid rotation. It might, however, be supposed that we should mention here the more or less vigorous coloration resulting in a given time, according to the different media through which the light must pass. This difference also exists: it would be useless to dwell upon it, unless we proposed to inquire into the various modes of producing it, and their causes. What we have endeavoured to point out is a difference of tone, the vigour of colour being the same.—*Bulletin Belge de la Photographie.*

DESCRIPTION OF A SELF-ACTING WASHING-CRADLE, WITH SOME OBSERVATIONS AND EXPERIMENTS ILLUSTRATIVE OF THE PROCESS OF WASHING PHOTOGRAPHIC PRINTS.

BY CORNELIUS HANBURY, JUN., F.C.S., ETC.

DURING the late beautiful summer I was induced to devote a little time to the practice of photography, after having laid it aside for nearly nine years.

I found that, during this long interval, some important improvements had been made in various parts of the collodion process. But, so far as I have learned, no great change has taken place in the general mode of washing prints, although the great practical importance of the operation early attracted attention, and numerous methods have in consequence been suggested for increasing its efficiency or diminishing the labour it entails.

The common plan of placing several prints in a vessel, through which a stream of water is allowed to flow, has always appeared to me very insufficient, unless some special and rather troublesome precautions are taken. I was therefore glad to find that similar views are expressed by Mr. Pouting in his instructive little work, entitled "Photographic

Difficulties." His remarks on the subject are so exactly adapted to my present purpose that I must request permission to quote them almost entire; as the words of an experienced, practical, and entirely independent witness, they have far more value than anything I could say on the subject. Mr. Ponting says (p. 102 *et seq.*):—

"There now only remains the removal of the hyposulphite of soda and silver; and perhaps this is the most troublesome and uncertain part of the whole process. * * * * *

"The only secure plan is so thoroughly and carefully to wash the print in abundance of clean water that it would be impossible for any soluble matter to remain. The way to do this effectually, with the least expenditure of labour in the shortest time is the problem to be solved. * * * * *

"The following is the method which the author has practically found to be the best, after eight years' experience.

"The print, being removed from the hypo bath, is held by two corners between the fingers and thumbs of both hands, the print hanging downwards, and is then passed under a stream of water issuing from a tap, and slowly moved to and fro through the centre of the stream; the upper edge of the print cuts the stream in two, a portion flowing over each side, so as to remove a very large quantity of the adhering hypo bath from the surface. A tray of clean water being provided, the prints are placed therein, care being taken not have too many at a time, or they will stick together so that the water cannot penetrate them. It will be necessary to move them about to obviate this. After soaking for 10 or 15 minutes

is as perfect as it is possible to be; and this may be effected in two or three hours. * * * * *

"An experiment was instituted to prove how long a time was occupied in changing the water in a tray by means of a running stream. A tray was filled with twelve pints of water, to which two ounces of ink had been added, and well mixed; water was then allowed to flow into it at the rate of three pints a minute. Not until three and a half hours had elapsed, and nearly eighty gallons of water had been used, was the colour of the ink entirely got rid of; and this, be it remembered, was without any prints to impede the flow of the water. There can be little doubt, therefore, that if the tray had been charged with a lot of prints, the water would not have been fully changed in three or four times the period; and unless the prints were moved, the probability is that the centre would scarcely be touched. This shows how difficult it is, by means of a stream of running water, to secure an effectual cleansing of the print."

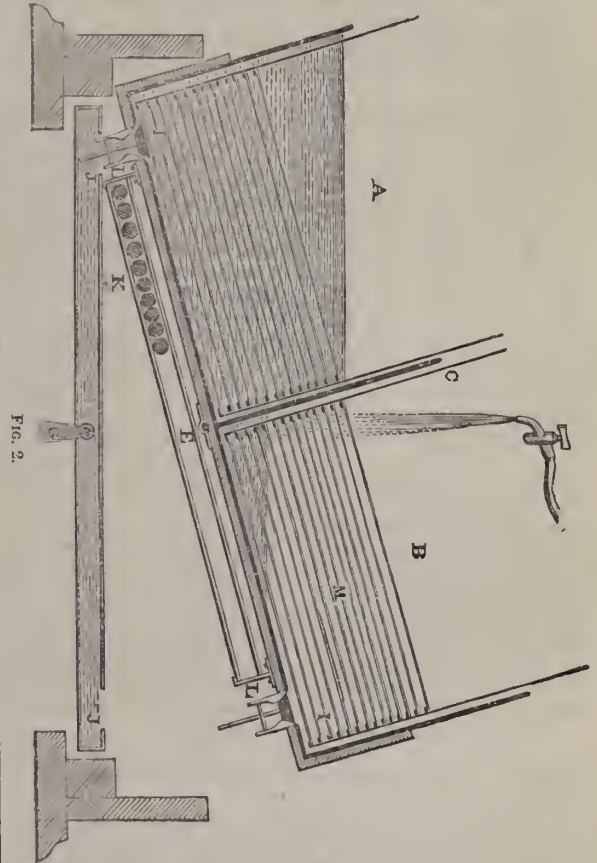
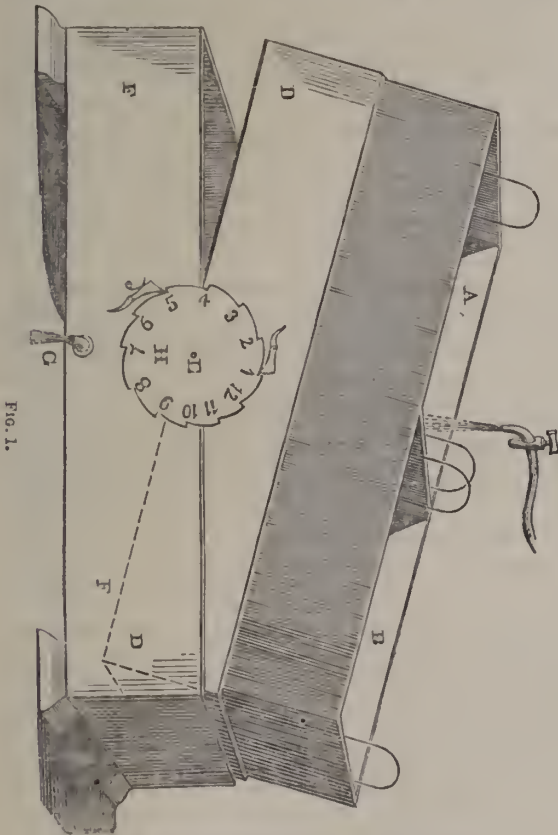

The method of washing here recommended is, I presume, the most efficient that can be suggested, and is only open to the objection that it involves so large an expenditure of time and attention that persons printing on a large scale can scarcely be expected to adopt it.

The simple apparatus which I have the honour to bring before the Society this evening will, I believe, be found to afford all the advantages of Mr. Ponting's method, whilst its employment demands no more time or attention on the part of the operator than the most careless use of the common tray.

A description of the apparatus will best explain its action, as well as its structure and principle.

Fig. I represents the apparatus in perspective. A B is a gutta-percha trough to receive the pictures to be washed. It is divided into two compartments by the partition C.

or longer, the whole of the prints should be taken out in a body, placed on a glass plate, and set up on edge to drain; the prints, being wet, will readily adhere. The washing vessel having been rinsed out and supplied with fresh water, the prints, after being left about five minutes to drain, are to be separated one by one and placed in the fresh water. If this process be carefully repeated some six or eight times, there can be no doubt that the removal of the hyposulphites

D is a wooden tray carrying the gutta-percha trough.

E is a metallic axis attached to the tray, D, and turning in gndgeons fixed on a strong wooden frame, F. From this it will be seen that the tray, D, and the trough attached to it, will rock with the motion of a see-saw upon the centre E.

H is a cog-wheel, into the notches of which one stop, attached to the tray, D, works, and another attached to the stand, F, thus causing the wheel to advance a notch each time the trough makes a complete oscillation.

Fig. 2 shows the apparatus in section. The letters indicate the same parts in each figure.

I I are conical valves opening into the compartments A and B.

When the trough is made to rock, as either end descends, the valve in it is raised by striking at the point J within a pipe, which discharges from the two ends by a common orifice at G.

K is a moving counterpoise, formed by a number of bullets rolling in a metal tube, L L.

M, moveable diaphragms or shelves, carried in a loose frame fitting into each trough, upon each of which a print is to be placed.

Fig. 3 represents the diaphragms and the frame which carries them.

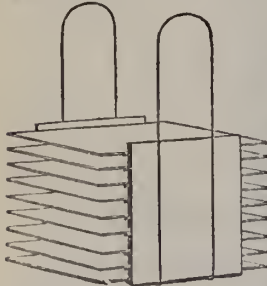

FIG. 3.

From the above description, it will be evident that when the axis of the apparatus is placed under a tap, if the water is allowed to flow, it will fall into the compartment which is uppermost (fig. 1 A), where it will accumulate until its weight causes that end of the trough to descend. When this occurs, the valve (fig. 2 I), will be raised, allowing the water rapidly to escape, from the lowest part of the vessel into the waste-pipe, and in a few moments each picture will be left lying on the inclined surface of a diaphragm to drain.

By the same movement the upper part of the partition C will be carried to the other side of the stream of water; and, consequently, it will now flow into the compartment B. At the same time, the weight, K, will roll by the force of gravity and place itself under the compartment which is becoming empty, where it will supply weight, in place of the escaping water, until the compartment B has received the quantity for which the apparatus is adjusted, when it will in turn descend, its valve will be opened, the weight will place itself underneath it, and A will again be filling.

By these movements, which will have once filled and emptied each compartment, the index will be moved on one division.

Thus the apparatus, when charged with prints, and placed under a stream of water, without any further attention, completely *changes* the water at definite intervals, allowing it to escape from the lowest part of the vessel. It exposes the prints *singly* to the action of the water. It *drains* them in an inclined position between each change. It *registers* the number of changes, and consequently the quantity of water passed over the pictures, thus enabling the operator to employ a definite and uniform amount of washing. And it causes sufficient motion among the pictures to prevent the adhesion of bubbles to their surface.

Experiment proves that, other things being the same, it washes in less than one-sixth the time of the ordinary tray, and with a proportionately smaller quantity of water.

The apparatus now shown has been made for me by Mr. Wood, of 74, Cheapside, who, with his usual skill, has excellently carried out my views.

Mr. Wood is prepared, I believe, to supply the apparatus of any size, and of the most economical construction.

In its simplest form, the apparatus may be made without

either valves or weight, merely having a hole at each end, through which the water may escape. But it then becomes necessary considerably to increase the length of the trough, and the angle through which it moves, in order to admit of the accumulation of sufficient water; and this is objectionable because the long descent causes a violent agitation of the water, and also because the water, whilst accumulating, lies too exclusively in the angle at the base of the partition.

These inconveniences are entirely overcome by the moving counterpoise, by means of which the angle of motion may be *reduced*, and the quantity of water accumulated between each change *increased* to any extent desired. The counterpoise may take various forms. I at first used a weight swinging, under the apparatus, at the end of an arm around a centre near one end of the axis E; but probably the cheapest and most convenient will be found to be a sufficient number of large bullets enclosed in a brass or tin tube, in which they can roll freely: as many of such tubes can be attached to the bottom of the trough as may be found necessary. In the small apparatus shown, mercury is substituted for the bullets; and it is placed in a glass tube in front of the trough, that its motion may be seen. One large ball will be found to produce an unpleasant shock, and the same disadvantage attaches to the swinging weight. Possibly a useful modification may be made, especially if a porcelain trough be desired, by prolonging the arm of the weight a little behind its axis, and there causing it to compress alternately caoutchouc tubes leading the waste water from the ends of the trough. No valves would then be required.

On a large scale it may probably be found advantageous to employ the swinging weight attached to a rod carried above the trough, parallel to the partition (C). The power of the counterpoise can then be adjusted either by its absolute weight, or by the height above the axis (E) at which it is placed, or by the length of the arm on which it swings, or, if sufficiently elevated and heavy, it need not swing at all.

If very large numbers of pictures had to be washed, the apparatus might take the form of a series of double troughs, placed side by side, along a common axis, each pair being supplied with water by a jet from a common supply-pipe placed, parallel to the axis, above them.

In the construction of the apparatus it will probably be found sufficient if the trough moves through an arc of 20° , which will give 18 divisions on the index wheel. The motion in the apparatus shown is 30° , and is unnecessarily great. It may be found useful to have a float-board to prevent the water slopping over when the full end descends. In the apparatus made for me, Mr. Wood has ingeniously added a second index-wheel in front of the first, but having one tooth more, and an opening in its face, which shows, one at a time, a second series of figures on the first wheel, and thus it very prettily records the number of revolutions of the first wheel; but such a provision is scarcely required.

I have tried numerous plans for keeping the pictures apart. My first attempt was to use straw mats of the kind employed for covering cream cheese. Then, with much trouble, I got some thin sheet gutta-percha corrugated so as to present a surface like the straws. Experiments soon proved that the plain gutta-percha without channels answered the same purpose and retained less water, and was less liable to injure the pictures; but it has the great disadvantage of adhering very closely to the paper after draining, and forming a mass which floats bodily, and only loosens again very slowly. Thus I was led to adopt diaphragms having an independent support. On the small scale, glass can be used. It may slide in metal grooves, such as are used for plate-boxes. On the large scale, probably tin plates may be used. The space between the diaphragms need not exceed the thickness of patent plate glass. As they occupy an inclined position, when the water enters, it drives the air before it, the stronger solution gravitates to the lowest part of the trough; and as no wave motion can occur in such a cell, when the water is discharged, it ebbs out, leaving the paper smoothly laid on the incline to drain. The support of the diaphragms directs

the water flowing from between them towards their ends, and thus prevents any tendency to float the prints down their inclined surfaces.

If the shelves are not perforated, the prints have a slight tendency to cling to their under surfaces. But when diaphragms of perforated zinc are used, the papers rise and fall with the water, and float about in the little space between the shelves with perfect freedom, leaving apparently nothing to be desired. Unfortunately, however, zinc acts on the pictures and cannot be used. Probably, ebonite similarly perforated will be found to answer. Should it prove expensive, or otherwise unfit, a material perfectly suited for these diaphragms will be a desideratum.

If we now imagine Mr. Ponting's experiment with the ink to be repeated with the arrangements here recommended, we shall see at once that the first change would empty out the ink, the second would rinse the trough, and the third would show no trace of it; and thus a few pints of water and a few minutes in time would effect what he found to require in a stationary tray 80 gallons of water and 3½ hours.

But it is worth while to consider a little more closely, how the removal of soluble salts from the tissue of paper is really effected.

If we could cause streams of water to permeate every pore and to carry with them by mechanical force all the matter which could be either dissolved or suspended, then the process of washing would be definite, absolute and perfect, and the duration of the operation would only depend on the rapidity of the streams. But we possess no such power. In the first place, a stream of water but very slowly removes water which is already adhering to a solid. Every chemist knows how surprisingly insufficient even the repeated rinsing of a test-tube often proves. In the circulation of the blood through the capillaries, and in the flow of any fluid through a small tube, the liquid immediately in contact with the pipe appears to be stationary, and is known to physiologists and physicists as the *still layer*. The phenomenon is no doubt due to the fact that particles of water are more powerfully attracted by those of most solid bodies than by each other, as is shown by the concave surface assumed by water in all ordinary vessels.

These considerations show how easily the particles of water in actual contact with a picture may allow others to flow over them without becoming themselves detached. By draining, however, a large portion of this adhering water is removed; and hence every experiment shows a much larger proportion of hyposulphite in the last drainings than in the bulk of the water discharged at each change. But for the removal of the hyposulphites from the *tissue* of a picture we are wholly dependent upon the property which soluble salts possess of *diffusing* themselves through the solvent which surrounds them; and thus it is that the process of washing becomes indefinite, comparative, and, in theory, only approximately perfect. All we can do is to secure the conditions most favourable for diffusion.

What these conditions are is thus stated by Professor Graham, whose beautiful researches almost created this important branch of chemical physics. He says, "The general law of diffusion appears to be this:—*The velocity with which a soluble salt diffuses from a stronger into a weaker solution is proportioned to the difference of concentration between two contiguous strata,*" (Graham's Elem. of Chem. ii. 608). The arrangements just described appear to secure these conditions with the least possible labour; but I am anxious that it should be clearly understood that *time* must ever remain an important element in any process depending on diffusion.

Each change of water subdivides the quantity of the salts in solution, and at first greatly weakens the solution left in the paper; but for the very reason, in accordance with the law just stated, diffusion goes on more and more slowly, the difference between the solution in the paper and the contiguous stratum of pure water becoming less and less. Hence the great practical importance of using a moderately small stream of water, and of continuing the process for a

considerable time after all appreciable traces of the salts have disappeared.

The principle of applying water in the most efficient manner to some primary purpose by making use incidentally of its own mechanical power, on some plan analogous to the one I have adopted, may probably admit of application in other processes. But if, by lessening the labour of the conscientious and the temptation of the unscrupulous, the suggestions here made should promote the better washing of photographs, and thereby the reputation of the art, my hopes and intentions will be fully realized.

Proceedings of Societies.

LONDON PHOTOGRAPHIC SOCIETY.

THE usual monthly meeting of this Society was held in King's College on the evening of Tuesday the 1st inst. COL. STUART WORTLEY in the chair.

The minutes of a former meeting were read and confirmed.

The CHAIRMAN said, in accordance with the 7th rule of the society, the names of retiring officers would now be read together with those nominated by the council to fill their places. The rule was as follows:—All officers of the society shall be annually elected, with the exception of the Secretary and such members of the council as may not go out of office by rotation or otherwise. The mode of their election shall be by ballot. The council at the ordinary meeting in December in each year shall declare the names of the members of council whom they recommend to retire, and lay before the society the names of those whom they have selected to supply their places. They shall also declare the names of the other officers they recommend for re-election, and cause a list to be suspended in the meeting-room. In the event of any member of the society being desirous of proposing other names than those recommended by the council, a written list of the same shall be delivered to the Secretary at or before the ordinary meeting in January; and the same shall be read from the chair, and publicly suspended in the society's room, with the list recommended by the council; and no member shall be eligible for election into the council unless he shall have been proposed in the manner and form above specified.

The names of retiring officers and those proposed, were the Lord Chief Baron, President, who was proposed for re-election. Mr. Vignoles, Vice-President, Col. Stuart Wortley being proposed in his place. Mr. Hamilton, Hon. Treasurer was proposed for re-election. The retiring members of the council were Messrs. Vernon Heath, Peter Lo Neve Foster, H. Pollock, Hennah, Col. Stuart Wortley, and Lord Henry Lennox. In their place were proposed for election or re-election, Messrs. Elphinstone Underwood, J. P. Gassiot, Josiah Slade, Sebastian Davis, H. Pollock, and the Hon. Warren Vernon. Any members of the society desiring to nominate other officers, must do so at the January meeting.

The SECRETARY called attention to some charming figure studies and examples of double printing, by Mr. H. Cooper, Junr., taken in the open air, chiefly by Dallmeyer's No. 1 triple lens, which were much admired; also to some of Mr. England's beautiful views of Swiss scenery, taken during the past summer.

Mr. SPILLER then read his paper on "Photography in its Application to Military Purposes," which was profusely illustrated with examples which were examined with great interest. No discussion followed.

The CHAIRMAN, in proposing a vote of thanks, remarked, that, as Englishmen, they were all deeply interested, and himself pre-eminently so, in the subject Mr. Spiller had described so ably. He had to announce that, at the next meeting, Mr. S. P. Smith would bring before the members some further particulars regarding the alleged photographs of the Eighteenth Century. He trusted that all the members would interest themselves in gathering together any evidence bearing upon the subject, and enable the society to pronounce definitely upon the subject, whether this country could claim the origin of photography at the early date claimed, or whether hitherto received claims remained undisturbed.

The following gentlemen were elected members of the society:—Messrs. Howe, Goslett, R. H. Michell, W. Rowland

Holyoake, C. A. D. Halford, Sydney Smyth, G. Hooper, F. G. Eliot, Major Gresley, Stanfield Grimshaw, Douglass S. P. Winsor.

The meeting then resolved itself into a conversazione, and finally adjourned to the first Tuesday in January.

THE AMERICAN PHOTOGRAPHICAL SOCIETY.*
FIFTIETH MEETING.

THE Society held its first meeting after vacation on Monday evening, Oct. 12th. in the University Chapel; the president, Prof. DRAPER in the chair; Mr. O. G. MASON was appointed Secretary *pro tem*. There was a full attendance of members.

After some miscellaneous business, Dr. HENRY DRAPER read a paper on Celestial Photography (see p. 550). The paper was illustrated by a mammoth photograph of the moon.

Mr. RUTHERFORD said he would only rise for a moment to give his testimony to the exceeding excellence and remarkable success of the photograph presented. He considered himself some judge of the matter, having been engaged in photographing the moon since 1857, with more or less results; and his experience taught him it was one of the most difficult things that could be attempted, because it involved the union of so many conditions on the same point and on the same occasion, before a fine result such as this could be obtained. In the first place, you must have a large, fine instrument. The instrument here used was a work of great ingenuity, patience, and skill; and Prof. Draper, in making it, had not only accomplished the photographic result before them, but had constructed a telescope of great power for astronomical purposes. Next, there must be the cleanest and most rapid application of photography, and then a very true and exact motion of the plate. They might well congratulate themselves that one of their own members, with instruments made by himself, had been so successful in producing the remarkable piece of excellence exhibited.

Effects of Light.—Mr. JOHN JOHNSON said it had been suggested to him, some time since, whether equal times gave equal photographic effects; and he exhibited some specimens produced by an ingenious contrivance, tending to show the negative of the proposition. There were also shown some interesting experiments on the different shades produced by various coloured glasses, exhibiting all grades of action, from extreme dark to none at all.

Influence of Light on the Growth of Plants, through coloured media.—Mr. JOHN JOHNSON read a paper, giving the result of experiments on this subject, made during the summer.

The PRESIDENT said that Mr. Johnson had directed their attention to two very interesting points, to which he would briefly refer. The first was, "Is the germinating or sprouting of seeds influenced at all by the colour of light that happens to fall on them?" That is, will seed germinate better under violet, yellow or blue? He has disposed of that, and I think, correctly. Indeed, when you come to look at the matter, every one must be convinced that light, in so far as its colour is concerned, has little or nothing to do with the germination of a seed. The simple fact that we place seed under a layer of earth is tantamount to an exclusion of light. The seeds germinate in the darkness, and the light has nothing to do with it. The second point is, what are the conditions when the plants are fairly growing? Does one kind of light prove to be more favourable to the development and growth of a plant than another? The experiments made settle that question (if it needed settling) in the most satisfactory way. Some kinds of coloured light are far more favourable to the growth of plants than others. In the book of Prof. Monekhoven, presented this evening, there is the strangest mistake; he affirms that it is actinic light (*i. e.*, the violet rays), which operates best in developing growth. Such is not the fact. It is light not actinic at all—orange, yellow, and green rays—which promotes the growth of plants; the violet, in the experiments I made, seemed to have no action whatever; the plants turned white, looked sickly in appearance, and very soon died. But it was very different with those growing under orange, yellow, and green rays.

Preserving Plates.—Mr. C. W. HULL produced a large-sized photograph taken from a tannin plate eighteen months old before exposure.

Col. PIKE, and other members, made some remarks showing

* Condensed from the *American Journal*.

the advantage of the dry process in preserving plates. A great deal depended upon thoroughly washing the plates.

Some observations were made on micro-photographs, which Mr. Rutherford characterized as mere toys, and hardly worth the trouble of mounting, after all your labour.

New Members.—W. H. Gilder, H. J. Newton, H. L. Boltwood, Wm. Vollmer, and A. Bogardus, acting members. Prof. John Towler, of Geneva, N. Y., a corresponding member.

Adjournment.—The Society adjourned to the second Monday in November.

Correspondence.

FOREIGN SCIENCE.

[FROM OUR SPECIAL CORRESPONDENT.]

Paris, December 2nd, 1863.

M. DE CONSTANT DELESSERT, a skilful amateur photographer, residing at Lausanne, has obtained instantaneous proofs by means of the double sulphate of iron and ammonia. He had a choice between a half-plate German lens of short focus and very quick acting, and a French objective, four inches diameter, of long focus, and comparatively slow acting, since it required 20 to 30 seconds' exposure in the operating room. To obtain rather large dimensions, he took the French objective, and with as short an exposure as possible, by opening and closing the objective with a hand screen, he obtained negatives with objects in motion. What particularly characterises these pictures, remarkable for their size, is the accuracy of perspective, and, in some, the sharpness of the distances. M. de Constant Delessert thinks that there will be an advantage in these conditions, in replacing objectives with short focus, which often give harsh and hard pictures, by those of long focus, which give greater delicacy. He developed the pictures with a bath of double sulphate of iron and ammonia, which gives great rapidity, and especially permits of slowly developing the picture by bringing out the shades without injuring the high lights. Perhaps, with the addition of formic acid to the sulphate of iron, still greater rapidity may be obtained. We purposely raise the question of formic acid, which has not yet been tried by many operators, and which has given contradictory results in the hands of several experienced operators. It would be very interesting to compare proofs of large dimensions obtained by this method with the charming specimens produced by M. de Constant Delessert.

M. Meynier, of Marseilles, to whom we are indebted for the introduction of the new fixing salt, has announced a new toning bath. It is obtained by dissolving 6 grammes (92 grains) of sulphocyanide of ammonium and 1 gramme (15 grains) of chloride of gold in a litre (35½ ounces) of water. We may remark in this place that the sulphocyanides now take a decided rank among photographic materials, their price is moderate, and their employment cannot be too strongly recommended, especially as they will supersede cyanide of potassium, from which so many fatal accidents happen.

Generally speaking, toning baths give better results after being made some hours than when newly prepared. M. Ommeganck, of Brussels, has recently given a formula for a toning bath containing both chloride of gold and copper, which, he states, works well as soon as made. This bath consists of—

Water	1 litre.
Chloride of gold	0.5 gramme
Deuto-chloride of copper	0.1 "
Carbonate of soda, until an alkaline reaction takes place.				

M. Ommeganck claims another advantage for this solution, that the tint of the proof is influenced by the presence of the chloride of copper; with a small proportion of this salt the tint remains black, but if the quantity be increased, it becomes blue grey. By varying the relative proportions of the salts of gold and copper, all the intermediate hues may be obtained.

REDUCTION OF RESIDUES BY LONDON REFINERS.

DEAR SIR,—We notice in your journal of the 27th inst., a paper written by a Mr. Jacob Ewing on the subject of "Photographic Residues," purporting to give Mr. Maenab's experience of the "respectable London refiners."

Ranking, we hope, as one of the "respectable" (though not advertising) London houses, and as having received a communication in December last from this same gentleman, we think it would have been more fair on the part of Mr. Ewing to have stated that the experience then obtained was not of the same character as that now detailed by him.

An inquiry (but no sample) reached us from Mr. Maenab, "What would be allowed in nitrate silver in exchange for 350 ounces of dry chloride?" The answer given was—"If perfectly pure and dry you would receive in exchange probably 380 ounces;" but a suggestion was made that the whole should be first reduced to ascertain the exact value. (This suggestion was rendered necessary from the fact that chloride of silver in bulk is so liable to variation from the kaolin and other impurities which are often thrown in with it, some portion of a parcel frequently yielding 74 per cent., while another portion will not give 50 per cent. of metal). This amounted to an offer for the chloride of 3s. 8½d. per ounce avoirdupois, or 4s. 0¾d. per ounce troy. (Chloride of silver is properly bought and sold by avoirdupois weight, as nitrate of silver and all preparations of the precious metals are.) Now the intrinsic value of chemically pure chloride of silver is 4s. 1½d. per ounce troy; this offer, therefore, left just ¾d. per ounce to cover the refiner's expenses of reduction and his profit.

The calculation made is here given—

350 oz. of chloride at 3s. 8½d. per oz. avoirdupois.	=£61 17 2
380 " nitrate " 3s. 5d. " "	=£54 18 4

In justice to the "respectable London refiners" (of whom we hope there are many), we trust you will find room for the insertion of this statement.

Mr. Ewing's letter reads too much like an advertisement in favour of Coghill's refinery.

If this parcel of chloride is the same as that referred to above, it will appear that Mr. Maenab realized £55 for what £64 18s. 4d. had been offered by one of the "London refiners."

The system of asking refiners to buy residues at a valuation, without previous reduction, cannot be too much depreciated. In justice to themselves they must allow a certain margin as a protection from loss through inferior residues. We think it would have been better taste to have given the refiner who offered 2s. per ounce for the chloride the credit of having made a mistake, either in halving the result of his calculation, or in being guided in his offer by some erroneous impression. We imagine that no one would knowingly offer 2s. for what was worth 4s.—certainly, not a "respectable London refiner."—We are, dear Sir, yours very truly,

MATTHEW BOLTON'S CAMERA.

SIR,—I read with interest the correspondence published in the NEWS of the 20th inst., and I send you some additional particulars and information which you are at liberty to publish.

There came a request some time ago from Mr. Powell to my brother to make a search for the old camera, but no tidings have as yet been heard of it; inquiries have now again commenced.

Mr. Powell is an intimate friend of mine, and showed me the old camera when he had it; and having then had some considerable experience in photography, I will give a description of it in the state I saw it.

The body formed a cube of about 12 inches each way; out of the front projected a square tube which would slide in and out, seemingly to get the "focus" of the lens. This was about 4 or 5 inches square, and when pulled out to the full extent

projected some 12 or 14 inches in front, like a long nose. It tapered off at the end, and terminated with a circular piece of wood having a round hole, turned in the middle, of 2½ or 3 inches diameter. There were no marks of screw holes on this piece of wood, as if any metal mounting had been screwed on, but the edges were levelled off, as if to simply push the lens in it. There was no lens in when I saw it, nor did Mr. Powell say that he had one with it.

The back part of the camera, which would receive the paper or silver plate, was devoid of fastenings for that purpose. I do not know if there were any in when Mr. Powell first got possession of it; but at the time I saw it, he had been putting some fastenings of his own to make his experiments.

This was its general form.

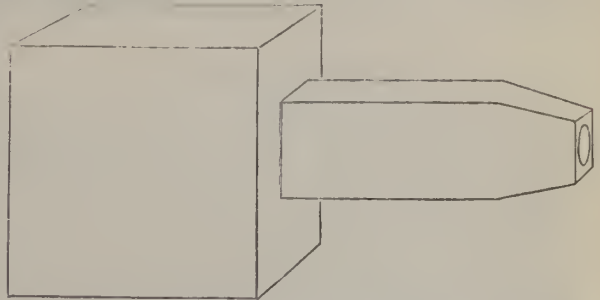

While looking at it at the time, to see if it could be of use as a camera, I thought it could be made serviceable by simply placing a groove at the back for the reception of a dark slide, and screwing a lens in front; I noticed that light would get through where the slide fitted in the front, but that would be remedied by throwing the focussing cloth over it.

In the letters No. 4 and 11 of Mr. Price's, there is a seeming contradiction. In No. 4, Mr. Powell speaks of it as "a most excellent instrument." In No. 11, it is described as "roughly made." The extreme age of the wood—unvarnished oak—gave it a lumbering look, but when examined, it was carefully and well made, not of course to bear a comparison with a modern camera.

I may add that Mr. Powell is very clever in making ingenious and accurate models of any object. I will warrant that he will make an exact model of the old camera, if paid for his trouble.

THOMAS KIRKBY.

Trentham, Staffordshire, Nov. 24, 1863.

Talk in the Studio.

STEREOSCOPIC PICTURES BY MR. GOOD.—We have received from Mr. Frank M. Good some very charming stereos of scenery in Hampshire, Dorset, and Devonshire. Many of the landscapes are enriched with well-disposed figures. There are also some instantaneous views of the sea and shipping, with fine clouds and sky. The selection is good, and the manipulation very satisfactory, giving rich vigorous pictures. Mr. Good uses bromo-iodized collodion, with iron development, and Dallmeyer's stereo lenses.

GREY VIGNETTES.—Mr. Watson, of Yarmouth, for whom a correspondent claimed, a short time ago, the origination of the vignettes which graduate into a flat grey tint, instead of white paper, has sent us some very fine examples of this class of work. As we before remarked, this method is of much older date than Mr. Watson's practice of it. Without any reference to the question of origin, however, these are exceedingly fine specimens of the class of work, and charming photographs altogether.

AUSTRALIAN PHOTOGRAPHS.—Messrs. Moira and Haigh have recently brought under our notice a very interesting series of photographs of scenery in the gold fields and other parts of Australia. They consist of about 150 stereoscopic subjects, and about 100 larger pictures. As they are not intended for publication, Messrs. M. and H. place them for the inspection of all

interested in Australian scenery and associations, at their rooms in Seymour Street, Portman Square. We are informed that the temperature frequently reached 120°, but that this caused no especial photographic difficulty, which the use of a weak nitrate bath and manipulating care did not easily overcome.

WEAK PRINTING BATHS.—Messrs. Sawyer and Co., of Newcastle-on-Tyne, have sent us some rich vigorous prints produced with a 35-grain silver bath, containing, as well, 40 grains of nitrate of soda, which they have been working with great satisfaction and success. They are especially forwarded to us as specimens of the work of the No. 1 B card lens with full aperture, and are surprising in this respect, as examples of definition.

PHOTOGRAPHIC FORGERY.—The conviction of Rinaldi, a Swiss, convicted of using photography to forge an Austrian note, has recently been affirmed on the ground that a photographic copy is a forgery, according to the meaning of the Act.

To Correspondents.

- E. S.**—The brown stains occurring on the application of the tannin arise from imperfect washing, and indicate the presence of free nitrate still in the film. These stains generally occur near the corner, and often at the end where the collodion is thickest. Some samples of collodion require much more washing than others, from retaining the free nitrate with much greater tenacity. 2. We have not tried any printing experiments very lately, press of duty and bad weather not permitting. Have you observed whether the mottling is produced by the removal of patches of the albumen, or by the absence of silver? 3. Some of the bargains advertised are doubtless genuine, whilst others may be deceptive. Persons purchasing under such circumstances risk something, to save something. Good articles may by chance be obtained at a low price; you can only be certain of excellence by paying its market value. 4. About 35 grains of chloride of sodium will be required to precipitate 100 grains of nitrate of silver.
- J. S.**—The estimation of the quantity of gold in a given solution is a very delicate operation. The hydrometer test is much too rough for practical purposes. It is one thing to ascertain whether a silver solution contain 50 grains or 60 grains to the ounce, but a different affair to ascertain whether a gold solution contain one grain or three. Mr. Francis Sutton recommends oxalic acid as a test, which precipitates the gold and is itself decomposed, one equivalent of gold decomposing three of oxalic acid. The use of protosulphite of iron has been recommended, but it is difficult to ensure the entire absence of a persulphate. The best practical test for a photographer is toning capability of a solution. Mr. Hart's volumetric apparatus is intended to be used with gold solutions. We are uncertain, at present, of the re-agent he intends to be used.
- W. S.**—Streaks in the direction of the dip arise from various causes. The presence of organic matter, or of accumulations of ether and alcohol in the bath, which must be got rid of by sunning and evaporation. A slight tendency to alkalinity, which may be removed by adding acid. The bath being rather strong, which may be remedied by dilution. The use of a new sample of cadmium collodion will sometimes cause it. Moving the plate laterally frequently, whilst in the bath, is a good thing when the tendency is present.
- N.**—Amber varnish, benzoin varnish, or dammar varnish, may be applied cold. The first is the hardest. The other two are slightly friable, and are apt to become tacky with the heat of sun printing. 2. Dilute gum water, or dilute albumen will preserve the film when it has a tendency to crack or peel. 3. We are not quite sure of your meaning when you refer to a paste for "mounting negatives." We have not used dextrine as a paste at all ourselves. It is, however, soluble in cold water. We have for some weeks past been trying gum tragacanth dissolved in 4 or 6 parts of cold water. It makes an admirable paste.
- X. Y. Z.**—We have had no experience in the cleaning of rolling presses; but should imagine that cleaning with a little rouge, or whiting and oil, would suffice, taking especial care to remove, by a subsequent dry polish, all traces of oil.
- J. KINGSLEY.**—Your vignettes, Nos. 1 and 2, are best; No. 3 is under-exposed and over-intensified; in No. 4 there is too much diffused light. To get a better tone print deeper and tone deeper.
- OLD SUBSCRIBER.**—We shall take an early opportunity of testing the bath. We do not think there is any danger of it not keeping, as we have kept it in solution for months, but have not tried it without the addition of some other salt.
- CANTAB.**—Where the albumen is removed by the bath of nitrate of silver and nitrate of soda, it is, we presume, from the use of a sample of the latter having a strong alkaline reaction. The addition of a few drops of nitric acid will probably remedy the evil.
- A BEGINNER.**—If the nitrate of silver stains have been on the floor some time, it will be very difficult to remove them. The application of a little tincture of iodine or hydrochloric acid followed by strong cyanide may effect it. 2. The lime toning bath is as economical as any you can use.
- DAK FOG.**—You can precipitate your bath as a chloride with common salt, and then reduce the chloride to the metallic state as we have often described.
- YOUNG PHOTO.**—If the camera be properly blackened inside, the rays reflected from its side will not produce much effect. When the body of the camera is extended, you may use the stop you describe, but take care that it is large enough to allow all the rays forming the image to pass through, and that it is quite black and reflects no light itself. 2. The only plan to get rid of texture in copying is to roll the print well; be careful in the lighting. 3. The allusion to taking views larger than portraits means that the front lens of the portrait combination can be unscrewed and used as a single view lens. 4. It is necessary to size albumenized paper with gelatine or

isinglass before applying oil colours. 5. We have no experience in the use of the liquid colours.

- G. AVERY.**—The long focus, No. 1 B, would probably answer your purpose, but requiring, as you state, 14 or 15 feet, you would be cramped for space in a room of 17 feet. In such case we should prefer to use the No. 1 B ordinary, which will doubtless answer your purpose satisfactorily, and give excellent results. You will not have distortion as you fear. 2. If the stop were used in contact with the lens, absolutely cutting a portion away, your argument would be more to the purpose; but the stop is always placed in such a position that all the lens is really used. The question is too large a one for general discussion here. The question of small lenses v. large ones has been the subject of much discussion in years gone by.
- H. B. LITCHFIELD.**—You can only obtain information as to all the photographs registered by application at Stationers' Hall. The list in our pages simply refers to those entrusted to our publisher for entering. 2. The copyright is secured for the life of the owner, and seven years after his death. 3. There is no object in registering a photograph of a picture which is not copyright, as any one else may copy the original. 4. Read the Copyright Act.
- ACETATE.**—The silver in old developing or intensifying solutions will generally precipitate in a metallic form, spontaneously; any remaining in solution may be thrown down as a chloride. 2. The best acetate formula is 1 grain of chloride of gold, and 30 grains of acetate of soda, in 6 or 8 ounces of water, made two or three days before use. 3. There is no necessity for using salt in the washing water. Three or four changes of water will remove the bulk of the free nitrate, and the use of salt is often a hindrance to toning. 4. One ounce of hypo in 4 or 5 of water will give a solution quite strong enough for fixing.
- R. P. H.**—Mr. Robinson's pictures are on albumenized paper. 2. The period of the Photographic Exhibition is not yet fixed.
- A BELFAST READER.**—The cause of your negatives cracking is, doubtless, damp. Any trace of chloride in the last washing water, after fixing the negative, or imperfect washing, leaving trace of the fixing salts in the film, would, in damp weather, favour such cracking. M. Claudet recommends, as a partial remedy, to rub the cracked negative with powdered charcoal or blacklead, with a piece of cotton wool, which, filling up the cracks, makes them print without showing the cracks.
- CONSTANT READER.**—We have never met with a case of the film leaving the plate after it is varnished. We should imagine that a dirty plate, or the presence of traces of hygroscopic salts in the film, must be the cause.
- D. DUNCAN.**—The Nos. of the PHOTOGRAPHIC NEWS out of print, and for which the publisher will give full price, are as follows:—6, 9, 41, 49, 53, 65, 76, 80, and 104.
- CLIFTONIAN.**—We cannot understand your experience. We have never had the slightest difficulty in using it. We have some now which has been made for months, which tones excellently. Your experience is isolated and anomalous. The addition of a drop or two of fresh chloride of gold solution would probably start the action and make the toning go on all right with the solution you now find useless.
- A YOUNG BEGINNER.**—The mode of treating a bath to remedy pinholes depends upon the cause, but the most common cause is the accumulation of lodonitrate of silver, and diluting and filtering is the proper remedy, afterwards making up the proper strength. 2. We do not understand the kind of stains you mean without seeing a plate. 3. About one-third of an inch stop will answer; place it in front about 1½ inch from the lens. In copying use such a stop as gives you satisfactory definition all over. About a 15-grain iron solution.
- WISLOW.**—It is impossible to give a rule for the "management of your light." It must be varied to suit varied sitters at various times of day, and in different states of weather. You must see that each sitter is properly illuminated. You are using too much light all round the sitter, and under-exposing and over-intensifying your negatives. 2. Use the acetate toning bath, and with good negatives you will get the tones you desire. 3. We have not tried either of the lenses you name, but believe them both to be pretty good of their class.
- ERRATA.**—In Mr. Barrett's letter in our last on "Transferring Negatives to Gutta-percha," the sentence in line 14 should read, "the bottle should be more than half filled with gutta-percha," in line 19, for "bearing" read "leaving."
- PAINTING BACKGROUNDS IN TINTS.**—We have received from Mr. Phillips a further reply to "R. A. S.," from whom he still conceives that he has received much less than justice. He now narrows the matter to one of personality, and is wishful to state his convictions as to the name and profession of "R. A. S." These conjectures are quite unsuited for discussion in our columns, and do not in any way affect the correctness of the opinions held by either party. "R. A. S." recommended backgrounds painted in black and white, or greys; and, in expressing this preference, did not recommend the production of anybody. Mr. Phillips recommends the use of tints, and has had an opportunity of justifying his preference. There the matter must rest, unless Mr. Phillips has more to say on the general subject, without reference to personal questions. Several Correspondents in our next.

Photographs Registered During the Past Week.

- MR. W. SULTON, Goat, near Cockermonth,
Two Photographs of the Rev. Robert Hall.
- MR. FREDERICK SNARY, 26, Castle Street, Bristol,
Two Photographs of the Rev. William Smith.
Two Photographs of Mrs. Smith.
- MR. W. W. WINTER, 2, Midland Road, Derby,
Two Photographs of the Rev. John Stevenson, A.M.
- MR. W. NOTMAN, Montreal, Canada,
Photograph of a Painting by R. S. Duncannon, entitled the
"Lotus Eaters," illustrating Tennyson's Poem of that name.
- MR. W. H. BARTON, 26, Triangle, Clifton,
Two Photographs of George Dawson, Esq., M.A.
One Photograph of the Rev. D. A. Doudney.
- MR. THOMAS WHITAKER, Bury St. Edmunds,
Two Photographs of Mr. F. Robson, Comedian.
One Photograph of Mr. and Mrs. F. Robson.
One Photograph of Mr. F. Robson, Mr. R. Thorne, and Mr. Shipman.

THE PHOTOGRAPHIC NEWS.

Vol. VII, No. 275.—December 11, 1863.



CONTENTS.

	PAGE		PAGE
A Photographers' Relief Fund	589	Photography in its Application to Military Purposes. By John Spiller, F.C.S.	596
The Management of the Nitrate Bath—Correcting Disordered Baths	590	Correspondence—Foreign Science—Chromophotography	597
Scientific Gossip	591	Notes and Queries—Coloured Photographs, or Double Toning—Measure of the Angle, &c.—Nitrate of Soda in the Printing Bath—Photography in a Gale—Automatic Washing Apparatus	598
The Discoverer of the use of Bromine in Photography—A few Facts and an Appeal. By Jabez Hughes	593	Talk in the Studio	599
The Use of Resin, &c., for the Reduction of Chloride of Silver. By F. W. Hart	594	To Correspondents	600
On the Strengthening of Collodion Negatives. By M. Mc A. Gaudin	594	Photographs Registered during the past Week	600
Children's Pictures	595		

A PHOTOGRAPHERS' RELIEF FUND.

THE rapid growth of photography, as a trade or profession, is, perhaps, unprecedented in the annals of industry. Within little more than the last decade of years it has grown from an amusement of the educated, or the occupation of a small number of professional Daguerrocotypists, in a few metropolitan cities, into an important branch of the industry of the world. The statistics of the art are not yet collated, but we risk nothing in stating that tens of thousands of persons depend upon its different branches for bread in this country alone.

Whilst it has been, and still continues to be, a fairly remunerative occupation to the many, the inexorable laws of political economy will affect it as they do all other trades. Demand for labour creates supply, with increasing supply must come competition, with competition decreased value; in short, it necessarily falls out that the mass of working photographers can only earn a fair living income. Photographers possess no immunity from accident, sickness, helpless old age, indigency. Life in the dark room is rather calculated to sap the foundations of health and vigour. Unlike many of the older industries, it has had no bequests from rich citizens, it has no almshouses or retreats, no fund or resource of any kind to which its unfortunate professors may apply for aid even in their utmost need. The question then forcibly arises, Has not the time come for the establishment of a Photographers' Relief or Benevolent Fund?

We do not pause now to argue the need. Cases have already arisen illustrating it. Specific appeal was recently made for Mr. Watson, who had lost his sight. This week we publish, on another page, an appeal which deserves especial consideration. The man who made photographic portraiture possible, who first introduced bromine into the art, and was one of the foremost amongst the early votaries of photography, is now, and has been for some time past, not only living on very precarious charity, but has been suffering absolute penury. With the instincts, education, and habits of a gentleman, he has shrunk from putting his own case before photographers, upon whom he has really strong claims. We have personal knowledge of the facts stated by Mr. Hughes in another page, and we are thus strongly confirmed by them in our conviction that it is full time a permanent Fund were established, to which such a man might appeal, without the natural hesitation which exists in delicate minds to ask for private charity. Such a Fund should exist, that personal and specific effort need not be invoked for each individual case which is necessitous and deserving. The proudest boast of this age and this land is, not its stupendous growth in science, art, or industry—its boundless knowledge—its almost unlimited powers; but that all these exist for the people at large, not for a few, as was the case in the civilization of empires which have crumbled into dust. It is the recognition of the claims of all, of the universal brotherhood of mankind, which constitutes the essential greatness of the age. Out of this recognition has

arisen the wonderfully perfect organization of benevolence which exists in every form. There is scarcely a phase of want, misfortune, or suffering, which is not met by its special and organized mode of relief. With the new want has come, hitherto, the new fund; and we feel that the importance of the subject to which we now ask attention, has to be but once considered to induce spontaneous recognition and prompt action. Until now its need has scarcely existed. Cases have just begun to arise, but, with the progress of time and the further growth of the art, they may be expected rapidly to accumulate, and will require an accumulating fund to meet them.

We should be glad to see this matter practically emanate from the Photographic Society, or at least be in some way associated with it. We think that an organization formed for obtaining and dispensing such a fund might claim the sanction and patronage of the highest person in the land; we feel assured it would obtain the aid and sympathy of all classes of photographers, from the highest to the lowest. We need not here plead precedents, such as Literary Funds, Dramatic Funds, Printers' Pension Societies, and a host of others, their existence is too well known to need repetition. Such an organization should know no class interests, no party feeling, no petty clique jealousies. We should like to see the hearty co-operation of all in such a project. We appeal to our brethren of the press to give it their generous consideration, and their powerful aid in publicity and advocacy. We do not attempt to point out the way in which the organization should be effected, or even at present to make a suggestion. We simply ask attention to the importance of the subject.

There is another incidental and collateral advantage, which will follow upon the formation of an organization for such a purpose. There will be common ground and centre of action for photographers, with unity of sentiment, which does not at this moment exist. There will be opportunities, or rather occasions, of meeting together, in a mode involving even more common sympathy, perhaps, than in existing photographic societies' meetings: there will be the anniversaries, and that annual dinner, without which no great work in England is said ever to be accomplished. This is, perhaps, a small thing to refer to in connection with such a subject; but such meetings are not without their significance and value. To the major question, however, we earnestly ask the attention of all classes of photographers, especially of those whose position, ability, wealth, and influence can at once give to such a movement success.

THE MANAGEMENT OF THE NITRATE BATH. CORRECTING DISORDERED BATHS.

In a recent article* on the management of the nitrate of silver bath, we dwelt chiefly, as a matter of primary importance, on the most approved methods of keeping a

* See p. 385.

hard-worked bath in good order. Second only in importance to this, are the methods of restoring the working condition of a disordered bath. To appreciate these properly, it will be first necessary briefly to examine the causes which operate in disturbing the desired action of the silver solution.

A hard worked bath is apt to get out of order in a short time, from the same causes which deteriorate a moderately worked bath in a longer time; but many operators are apt to forget the hard work, and wonder that the bath gets out of order in such a short time. Besides the well known causes of deterioration, various doubtful causes are often suggested. The use of bromo-iodized collodion is a favourite cause on which to place the blame with many excellent photographers, who have had long and successful experience with iodized collodion. We do not see any theoretical reason for this supposition, and we have never found any bad results in practice, to believe that it deteriorates the nitrate bath in any respect. A very able photographer called our attention recently to a very curious experiment. A nitrate bath, in which he had been testing several samples of commercial collodion, refused to work, giving foggy, unsatisfactory results. Thinking that it possibly arose from impoverishment of the bath, he added some crystals of nitrate of silver, upon which immediately ensued a precipitate in powder of a bright yellow colour like sulphur. This experiment he repeated in our presence. We have not had opportunity of further examining the bath or the precipitate, or inquiring into the details of its history. Our friend, an able photographer, had come to the conclusion that it was bromide of silver, the precipitate answering to many of the characteristics bromide attributes to that substance. We took exception to that conclusion, because it did not answer to the qualities we have found in bromide of silver, which we have always found to be of a much lighter tint, rather resembling a light cream colour than yellow, and we believe it to be soluble in a strong solution of nitrate of silver, rather than in a weak one, as this substance was. We mention the circumstance here, in order to ascertain if any of our readers have at any time met with a similar precipitate.

The use of impure methylated solvents in the collodion may doubtless be at times chargeable as injurious to the nitrate bath. But it is to *impurity* we believe the injury is due. We believe that methylated ether and methylated spirit of good quality have no injurious effect in collodion, and we say this after considerably extended experience in their use*. If the methylated ether be good, and the spirit have been especially rectified, no evil will arise from its employment in collodion. The injurious results arose from the use of methylated spirit containing a variety of essential oils and other contaminations, which soon react upon the nitrate of silver bath in an injurious manner, and hence the evil which has been attributed indiscriminately to the presence of methylated compounds. Whether the solvents be methylated or not, there is every reason to believe that the presence in the collodion of fusel oil and various essential oils is injurious to the nitrate bath.

The use of impure iodides may occasionally be injurious; but we do not think that this is a common evil. Empirical compounds may occasionally be used for improving collodion, and these may occasionally, by accumulating in the bath, become injurious; but we do not think that this is a frequent evil. Nitrate of silver may not infrequently be contaminated with impurity, but we believe that designed adulterations are rare.

Without adverting further to hypothetical sources of derangement with nitrate bath, we will glance briefly at some of the known defects, with their causes and remedies.

Streaks in the direction of the dip and fog often proceed from the same cause—either alkalinity of the bath, or the

presence of organic matter. If the addition of a little nitric acid do not remove the evil, the bath may be sunned. Sometimes the streaks arise from the accumulation of ether and alcohol, which seem to exercise a slightly solvent effect on the film of iodide of silver formed, and produce the streaks in the direction in which the plate moves. Evaporation by exposure in an open vessel, and gentle heat, or boiling down, is the remedy. Sometimes the presence of scum on the surface of the solution will produce streaks. Drawing a strip of paper across the surface of the solution most effectually removes such scum. Streaks will often be observed immediately after strengthening a bath with fresh silver or strong solution, and will disappear after working a few plates. The fresh solution, not being iodized, exercises a slight solvent action on the iodide of silver formed; and of course that action is shown in the direction in which the plate moves. The remedy is leaving a coated plate in the bath a short time.

Pinholes and Spots.—These are amongst the most annoying troubles to which the photographer is subject, and the causes are so numerous that they are not always easy to detect. The pinholes with tails to them may almost always be remedied by the use of a larger proportion of bromide in the collodion; but the small round holes, which seem most plentiful in the dense parts of the picture, are more difficult to deal with. Dust, either in the bath or camera, is a cause too obvious to be mentioned. Supersaturation with acetate of silver is an occasional cause, and one difficult to remedy; continued exposure of the bath to strong sunlight is a partial remedy. The presence of oxalate of silver in the bath, arising from the use of old and partially decomposed collodion, is an occasional cause. When this is the case, the bath may be seen to be slightly turbid, and after standing a few hours a precipitate will fall, and the bath will again give clean plates. The best remedy is to avoid the cause. The most common cause of pinholes is the well known accumulation of iodo-nitrate of silver in the bath from long use. The best remedy is to dilute the bath with an equal bulk of distilled water, which will cause a precipitate, which, being filtered out, the proper amount of nitrate of silver is added to make up the strength. There are probably some other causes not well understood. It is noticeable that these spots will often be troublesome in warm weather, and disappear in cold weather. They will sometimes appear chiefly in a bath with much accumulated alcohol, and disappear after evaporation. Rest will sometimes cure a bath; sunning frequently, and boiling down occasionally.

A singular and empirical remedy for the many troubles of the bath is found by some operators very efficacious in removing a cloud of evils afflicting the nitrate bath. It consists in the addition of a little pure cyanide of potassium in solution. The result which might be expected would be simply the precipitation of cyanide of silver, and the formation in the bath of nitrate of potash. But something more than this seems to take place; needle-like crystals, which were seen floating in the bath and clinging to the dipper, are dissolved, and impurities are carried down by the precipitate. Whatever may be the action, the result is often very beneficial.

Want, or Excess of Density.—Want of density, when caused by the nitrate bath, is generally accompanied by fog. It may be caused by excess of nitric acid; neutralizing is then the remedy. It may be from the formation in an old bath of acetic ether; carbonate of soda and sunning are the best remedies. It may be from impurities in the nitrate; for which neutralizing must be followed by sunning. The addition of a little acetate of silver will often add to density, but we don't like the remedy. Excess of density is often due to the presence of acetate of silver, or the accumulation of organic matter; sunning is a good remedy.

Neutralizing an Acid Bath.—The use of oxide of silver, which is theoretically the best method, is not always practically the most efficient. If it be used, it should be freshly precipitated by adding a little of a solution of caustic

* It has been recently suggested by a contemporary that the injurious effect of the methylated spirits in collodion is chiefly found with pyrogallic development. Our own experience is chiefly with iron development, but we occasionally use pyrogallic acid with the same collodion and bath, without perceiving any ill effect with either wet or dry plates.

potash to a solution of nitrate of silver. The brown precipitate, having been washed in two or three waters, is then added to the bath until it is decidedly turbid, the solution well agitated and left for a few hours before filtering. The addition of carbonate of soda, besides neutralizing the bath produces another good effect; it throws down a precipitate which often takes with it other impurities present. A ten-grain solution of bi-carbonate of soda should be kept ready and added a few drops at a time until a permanent turbidity or precipitate is formed, which is not redissolved on agitation.

Adding Acid to an Alkaline or Neutral Bath.—The addition of acetic acid to a bath is a source of frequent derangement, and when once added it is difficult to eliminate. For these reasons it is better to avoid its use as much as possible. Dilute nitric acid is the most convenient for use. A drachm of strong nitric acid in 4 ounces of distilled water is convenient for use, half a drachm of the dilute acid containing a fraction over a minim of strong acid. By the use of such a preparation acid can be conveniently added in infinitesimal proportions. After each addition of acid the bath should be well stirred or agitated, and left to stand some time, as if tried immediately after the addition, its full effect will not be perceptible.

Sunning a Bath.—The bath should generally be neutralized before sunning. If it can be done conveniently, it is best exposed in an open vessel, which permits evaporation at the same time. Where this is not convenient without danger to the solution, it may be exposed in a bottle: several hours' action of strong sunlight is desirable. The solution should be then filtered, and tried before adding acid, as it will frequently be found that, after neutralizing with carbonate of soda, and sunning, a bath will work well without any addition of acid.

Evaporation and boiling down.—The partial evaporation of excess of ether and alcohol may be effected by placing the solution, for some hours, in an open vessel, in a warm place, or over a water bath or sand bath, at a very low temperature. In order to effect the entire removal of all traces of spirit, or to remove acetic acid, it is necessary to boil down the solution to dryness. Many American photographers rely on partial boiling down, as the best mode of removing almost all the ills a bath is heir to. The operation is one requiring great care. It may be effected in various ways. If partial boiling down only is intended, the solution may be placed in a well annealed flask, and supported in a retort stand; a spirit lamp with wire-gauze burner is then placed underneath, not too close at first. If boiling down to dryness be intended, the solution should be placed in an open glass dish, or evaporating basin, and placed over a water bath, the heat being raised gradually. A method may be improvised by placing the solution in the most convenient glass vessel which will stand in an ordinary open cooking vessel. The glass vessel must not stand on the bottom of the pan, but be supported by some means—if it rest on a piece of tile, it will do. The heat must be raised gradually. Frequent stirring will assist evaporation, and prevent "bumping." Well annealed vessels should always be used.

Preparing pure Nitrate from Old Baths.—One of the drawbacks of the various methods of correcting a disordered bath rests in the fact that they are often very liable to rapid deterioration again, and it finally happens that the bath has got into a state of hopeless imperfection. The remedy is then to precipitate it entirely, and reconvert it into nitrate. There are various modes of doing this; we will mention two or three. The first is strongly recommended by Mr. Gage, a skilful American photographer. Place 30 ounces of solution in a Winchester quart bottle, and add bicarbonate of soda, a little at a time, until the whole of the silver is precipitated as a carbonate, stir or shake the solution now and then. Take care that all the silver is precipitated; a little excess of soda will do no harm. Now pour off the water closely, without letting any of the precipitate escape. Re-

peat this six or eight times, so as to be sure of washing off all the free nitrate of soda.

Distilled water should be used for the last washing. After having drained it as closely as possible, proceed to add pure nitric acid, to dissolve the precipitate, stirring with the glass rod at the same time; continue to add until the precipitate is nearly, *but not quite, all dissolved.*

The solution at this point of the proceedings will probably be opaque and almost inky black. This need not cause any alarm, as it will filter out clean and pure. Now add distilled water to make up the bath to the original bulk. For certainty, it may be as well to test the strength, either with the hydrometer or by the volumetric process. Filter two or three times thoroughly, and it is ready for use. Mr. Gage says:—"Baths for negatives treated in this way work decidedly clearer, better, and quicker than in any way I have ever tried. It also gives better delineations in positives. The experimenter, by this method, will be astonished at the amount of black or green matter that will be found in the funnel after filtering the first time, and will be able to see what fogged his pictures." He adds:—

There are some points of importance to be attended to in this process. They are these:—

1st. That the bicarbonate of soda be pure.

2nd. That the resulting precipitate be well washed, to free it from all soda that is not all absorbed and combined with the silver.

3rd. That the precipitate be *not all dissolved* before it is filtered. If this part is not attended to, you will lose your labour. The theory of this is, that the *organic matter* in the bath is *soluble in acid* and cannot be filtered out while the bath is acid. There need be but very little precipitate left in, as the least amount undissolved will leave the bath perfectly neutral.

Another method consists in first reducing the bath as a chloride by the addition of common salt, and then washing the chloride several times. Then place amongst it some clean wrought-iron nails, and a little dilute sulphuric acid, say one ounce of acid in four ounces of water for each four ounces of chloride. In about 24 hours the whole of the silver will be found reduced into a grey metallic powder. Wash this with weak sulphuric acid, then with several changes of water until every trace of acid is removed. Next redissolve in dilute nitric acid; the result will be very pure nitrate of silver. There are other modes of effecting this, but these will suffice.

We have now given a brief *resumé* of the chief modes of correcting a nitrate bath; all of them are perhaps pretty well known, but our object has been to collect and condense them for general reference.

Scientific Gossip.

CONSIDERING the vast number of organic substances being every day brought to light by the labours of chemists, it is somewhat surprising that so few of these bodies have been made available for utilitarian purposes. Amongst the thousands and tens of thousands of new ammonias and organic bases which have been discovered of late years, scarcely one has given signs of possessing the least interest outside the charmed circle of chemists, which meet on alternate Thursdays at Burlington House. In one of his early memoirs, Dr. Hofmann referred apologetically to the swarms of new ammonias, of which he was the prolific parent, by comparing them to paving stones—of great use in constructing a firm path for future use, but of no individual interest when once obtained and their position and composition settled. But to some of these bodies we can hardly accord so useful a position as a paving stone. With their mode of atomic arrangement unknown, their proper position in respect to surrounding bodies unsettled, and their behaviour under the various forces to which they can be subjected, they may be better likened to crude and ill-shapen blocks of ore, hewn

by the workman from the rock, and scattered at random for others to utilise.

Foremost amongst the vigorous miners in organic chemistry stands Dr. Frankland. Scarcely a month passes without chemists being gratified by some new result, which this talented professor has elaborated with no less skill than penetration. His discoveries, especially in relation to organo-metallic bodies, are always of interest; and his latest research promises to be of some practical importance, besides being of scientific value.

By allowing iodide of methyl to act upon sodium amalgam, in the presence of a little acetic ether, a compound is obtained called mercuric methyl. This, after purification, is obtained in the form of a colourless, highly refracting liquid, of the specific gravity 3.069, being in fact the heaviest known liquid, with the exception of mercury itself. So dense is it that a piece of heavy lead glass will float upon it. The author states that in the event of this organo-mercuric compound being required in quantity, no difficulty would be experienced, as iron vessels could be used, and the process could be conducted continuously; thus syphon tubes could be made to draw off the residual mercury, and the products themselves, whilst fresh materials could be supplied by injection. Upon seeing the specimen of mercuric methyl handed round at the last meeting of the Chemical Society, the idea occurred to an ingenious correspondent of the *Chemical News* to apply this liquid to the manufacture of prisms. At present, the only liquid suitable for this purpose is bisulphide of carbon, which is not above half the density, besides being objectionable from its offensive odour, its great volatility, and the ease with which it ignites. The mercuric methyl appears to be superior to bisulphide of carbon in all these respects; and as its preparation in quantity would be attended with no particular difficulties or expense, we hope that some enterprising instrument maker will not be long in adopting this very valuable suggestion. Besides its use for prisms, this liquid might be advantageously employed in the manufacture of lenses. Formerly, compound lenses, in which one of the constituents was a fluid held between outer meniscus lenses, were somewhat in vogue, but were abandoned owing to the advantages of their construction not being sufficiently great to counterbalance the difficulties.

The well-known French chemist, Chevreul, who has devoted so much attention to the subject of colour, has lately published a memoir on painted windows, in which there are many points which deserve the attention of artists and others who are interested in the manufacture of coloured glass. It has often been noticed that old stained glass windows have a much richer effect than modern ones, and M. Chevreul, speaking of this superiority, attributes it to what we moderns regard as defects. In the first place, much of the ancient glass is of unequal thickness, or, in other words, the two surfaces are not parallel, and so present convex and concave parts, which refract the light differently, and produce an agreeable effect. In the next place, the old coloured glass is not a colourless glass, to which has been added the particular colouring material, such as protoxide of cobalt, &c. Old glass contains a good deal of oxide of iron, which colours it green, and to this must be attributed the peculiar effects of antique glass coloured by cobalt and manganese. M. Chevreul appears to think that modern stained glass is too transparent to produce the best effects. M. Regnault, another admirer of the "dim religious light," has recommended that all this kind of stained glass should be cast, to avoid the monotonous effect of plain surfaces on the light; and also that foreign substances should be mixed with the glass to diminish its transparency.

The formation of gun cotton from ordinary cotton is well known to our readers; the change consists in the substitution of two or more equivalents of nitrous acid, NO_2 , for the same number of equivalents of hydrogen. The same change may be produced in many other organic bodies; for instance, glycerine, when treated with a mixture of nitric and sulphuric acids, becomes converted into a nitro-glycerine or

glonoine, an oily liquid having explosive properties when heated. Many experiments have been tried with this substance, respecting the remarkable action which it exerts upon the animal economy, the glonoine being administered by dropping it, or its alcoholic solution, upon the tongue. The principal effect which has been noticed is the production of violent headache, accompanied by great prostration of the system. Mr. T. M. Merrick has recently had the courage to try some experiments upon himself, and, considering the violent toxic properties of this curious substance, and the peculiar manner in which it acts, the experiments are doubtless more interesting to the reader than to the experimenter. The first experiment was an accidental one; a dish containing a solution of glonoine in ether was, by some mishap, tipped over, spilling half its contents on the sand bath, and, in a moment, the room was full of the mixed vapour of glonoine and ether. A large volume of the mixed vapour was inhaled. No immediate bad result followed, but in less than fifteen minutes a headache set in, slight at first, but increasing in intensity by degrees, until, in an hour and a half, it became almost intolerable. It was accompanied by a good deal of faintness and exhaustion, intolerance of light, and a feeling of great general distress and alarm; consciousness, however, not being lost for an instant. The unpleasant symptoms did not disappear for three or four days. After this experience of the powerful action of the liquid, Mr. Merrick was a bold man to deliberately lay himself out for a repetition of the effects; but there is no knowing what an enthusiast will do in the cause of science. Wishing to ascertain what would be the effect of swallowing a minute quantity of glonoine, he prepared a solution containing two and a half drops to ninety-seven and a half of alcohol. One drop of this liquid, containing the fortieth of a drop of glonoine, was swallowed on a piece of loaf sugar. In two minutes the pulse had risen considerably, with a dull throbbing headache. In five minutes the pulse had risen higher, the headache changing from the back to the front of the head. In fourteen minutes the pulse had sunk again to its normal rate, although the pain in the head did not pass off for fifteen minutes more. This experiment shows that glonoine is a body which rivals in intensity the strongest organic poisons; it proves the necessity there is for extreme caution in handling, and especially inhaling or tasting substances the nature of which is not thoroughly well known. In inexperienced hands, glonoine may be a poison of the most mischievous character; although when employed by skilled physicians, it will, no doubt, prove a valuable physiological agent.

Messrs. Deville and Troost have lately discovered a curious property of platinum. In some experiments upon high temperatures, they were induced to suspect that the platinum vessels employed were somewhat porous to gases. They accordingly tried a definite experiment, with the object of ascertaining this. A platinum tube was placed inside a porcelain one; through the former a current of atmospheric air was passed, whilst hydrogen circulated through the latter. The pipe and delivery tubes were so arranged that the gases could not mix, but passed through and were collected apart, being separated by a solid and continuous partition of well worked platinum. At the ordinary temperature the hydrogen passes along and may be collected at the other end in the pure state, whilst the air retains its normal composition. When the temperature is raised, however, to a red heat, a change occurs, the platinum at this temperature is porous to the hydrogen, which accordingly passes through the metal, and unites with the oxygen of the atmosphere, forming water, which may be collected and weighed in appropriate apparatus. It has been proved further that the porosity increases with the elevation of temperature: at the highest point tried (about $1,100^\circ \text{C.}$) the whole of the atmospheric oxygen unites with the hydrogen, and nothing passes out at the other extremity of the apparatus but nitrogen and aqueous vapour.

THE DISCOVERER OF THE USE OF BROMINE IN PHOTOGRAPHY.

A FEW FACTS AND AN APPEAL.

BY JABEZ HUGHES.

As the early history of photography is now engaging attention, a statement of the claims of a little-known discoverer will not be out of place.

To John Frederick Goddard we are indebted for the first discovery and publication of the use of bromine in photography. The interesting circumstances attendant afford an opportunity of recording some facts connected with early photography as illustrated in the Daguerreotype process.

Daguerre, after many years of experimental labour, announced his discovery, in January, 1839, and showed specimen pictures; but it was not till August in the same year he disclosed the process itself, the French Government having in the interval purchased the secret, "as an invention that did not admit of being patented," and they generously published it "for the glory of endowing the world of science and art with one of the most wonderful discoveries of our native land." Nevertheless, Daguerre, while negotiating with the French Government, secured a patent in England.

Daguerre made few improvements; in his hands the process was only able to delineate still life objects, for an exposure of twenty minutes or half an hour, with bright sunshine, was required. Enterprising individuals, however, immediately practised the art, and went forth armed with this new power to depict celebrated monuments and other objects. Many of these thin, filmy, shimmering pictures were exhibited in London, and offered for sale at the Polytechnic Institution. They were taken on plates $8\frac{1}{2}$ by $6\frac{1}{2}$ inches, and, though wondrously admired as curiosities, found few purchasers. The prices ranged from one guinea and a half to two or three guineas each.

Up to this point Daguerre's discovery remained as a scientific wonder, but with little commercial value. Improvements were required so that impressions could be taken quickly, and in a subdued light; and these improvements were first made by Mr. Goddard.

The circumstances of his introduction to photography are curious. When the particulars of Daguerre's process were published, Professor Morse resided in Paris. He communicated the details to the scientific men of New York, many of whom immediately commenced experiments, and, among others, Messrs. John Johnson and A. Woolcott, who worked together. Mr. Woolcott, with a view to take pictures quicker, devised a camera with a concave mirror, instead of a lens, and the plate was placed in the focus of the mirror. By this means they were able, so early as October, 1839, to take a profile portrait of Mr. Johnson, with only *five minutes'* exposure in the bright sunshine, the plate being not quite three-eighths of an inch square. In January, 1840, Messrs. Johnson and Woolcott were so far satisfied with the improvements they had made in the reflecting camera (they were able to take portraits $2\frac{1}{2}$ inches by 2), as "to entertain serious thoughts of making a business of taking likenesses from life." Early in February, 1840, Mr. Johnson, sen., came to Europe with a few of the likenesses, with the intention of patenting the reflecting camera.

Mr. Carpmael, the patent agent, being engaged with Mr. Beard on patent business, called Mr. B's attention to this subject as likely to be a good speculation, and Mr. Beard united with Mr. Johnson in taking out letters patent for the reflecting camera. This was Mr. Beard's first introduction to photography. As neither Mr. Beard nor Mr. Johnson were men of science, but engaged in commerce, they felt it necessary to secure a competent person to bring out their new camera. They applied to Mr. Longbatham, of the Polytechnic Institution to name a gentleman likely to aid them. He mentioned Mr. Goddard, then engaged as lecturer on optics and natural philosophy at the Adelaide Gallery, as a gentleman exactly suited for them, if they could secure his services. Mr. Goddard, who was already familiar with the Daguerreotype process, entered into the project with zeal, engaging himself to undertake experiments to test the value of the new instrument, and also to endeavour to improve the process itself. This was about Midsummer, 1840, and although Daguerre's discovery had been about a year before the public, excepting this reflecting camera, no improvement whatever had been made.

Mr. Goddard soon found that, as all his pictures required continuous sunshine, even with his "quick-acting" camera—to use a modern phrase—he was often obliged to suspend his experiments for want of light (his premises were in Holborn), so he set to work to find a means to take pictures without direct sunshine. In the Autumn of 1840 he discovered the extreme sensitiveness of the use of bromine with iodine, a discovery which reduced the exposure from minutes to seconds, and permitted pictures to be produced in a subdued light. This valuable discovery was published in the *Literary Gazette*, December 12th, 1840. Mr. Goddard saw at once the value of his discovery in a commercial sense, and recommended Mr. Beard to purchase the patent from Daguerre, in whose hands it still remained; and also to abandon his reflecting camera as no longer necessary, but to use lenses by which larger and better pictures could be obtained. Mr. Beard had the wisdom to avail himself of these suggestions, and from this time dates the commencement of a new industrial art—professional and commercial photography.

After this, Mr. Goddard instituted an elaborate series of experiments on the haloid bodies. Iodine, bromine, chlorine, and fluorine, and in Feb., 1841, he deposited a paper in the Archives of the Royal Society, detailing his sensitive process of chlorine with iodine for taking portraits from life. A copy of this paper was presented to each of the licensees of Mr. Beard, as directions for making their sensitive solutions.

With the exception of M. Fizeau's method of gilding the plate, no vital discovery was ever afterwards made in daguerreotype, all other improvements were but matters of detail.

The introduction of bromine into photography enabled it to pass from a curiosity of the laboratory to be one of the proudest discoveries of the nineteenth century. It became immediately a new and unique source of happiness to mankind—a boon and a blessing to all brought within its influence. Due honour has been rendered to the great primo movers—Daguerre, Fox Talbot, Archer—but the claims of one still living amongst us, who found the art at a dead-lock, and who gave it an impetus which it has never lost, are not so well known. They have never been so fully stated as in this paper, and, perhaps, would not have been so urgently made now, but that the worst part of my story has yet to be told—this worthy man is in want! He is old and frail; he has well-nigh reached the Psalmist's "threescore and ten;" and he is in penury—literally without means—and is living on charity.

It is proposed to raise a fund to relieve the necessities of this deserving gentleman; and I appeal to all photographers to honour themselves and their craft by rendering the few remaining years of this early father in photography free from at least the anxieties of physical want.

Mr. Goddard has spent the greater part of his life in scientific pursuits. In the Society of Arts Session, 1837-8, he received the silver medal from the society for his apparatus for experiments on polarised light, and at the same session he contributed a paper explaining the subject. He was one of the earliest lecturers on the oxyhydrogen microscope, and was engaged lecturer at the Adelaide Gallery and the Polytechnic Institutions on optics and kindred subjects. He brought out the opaque microscope, that marvellous instrument, that exhibited a highly magnified drop of water, with its myriads of horrible inhabitants. He was the first to exhibit a highly magnified photographic image on the screen of a lecture room, the subject being a Daguerreotype of the late Prince Consort, in the presence of the Prince himself.

Fifteen years ago, Mr. Claudet, in the *Philosophical Journal*, when discussing the priority of discovery of the use of bromine, frankly conceded the honour to Mr. Goddard, and used these words:—"The name of Mr. Goddard should be honourably mentioned in the history of the progress of photography; not only for the discovery to which I have just alluded, but also for having been one of the first in England who investigated with zeal, enthusiasm, and scientific ability, the phenomena connected with this admirable invention."

I leave the matter now in the hands of the photographic public, confident that I have but to make the appeal to those who have profited by the practice of the art, to give from their stores to solace the declining years of one who helped the art when it much needed it.

To give effect to this appeal, the gentlemen whose names are appended will thankfully receive contributions, and their names will be a guarantee for the accuracy of the statements made, and for the proper application of the funds.

All monies collected will be duly acknowledged in the Journals.

Dr. DIAMOND, Twickenham House, Twickenham.
G. WHARTON SIMPSON, 18, Canonbury Park South, N.
T. R. WILLIAMS, 136, Regent Street, W.
JABEZ HUGHES, 379, Oxford Street, W.

THE USE OF RESIN, &c., FOR THE REDUCTION OF CHLORIDE OF SILVER.

BY F. W. HART.

IN the process of reducing silver for testing purposes, recommended for use with my Volumetric Apparatus, the chloride is reduced by nascent hydrogen formed in the decomposition of water, the zinc or iron being oxidized (at the expense of the water) before the sulphuric acid can dissolve it; by this means the other element composing the atoms of water is liberated, and then immediately combines with the chlorine of the silver salt, which is split up, leaving metallic silver.

Most reductions from solutions, except in the case of electro depositions, are pulverulent, and require an after application of intense heat to bring the particles into a solid mass. This fact renders desirable a method of reduction which does not involve two operations. Discarding the common methods, I adopt a plan similar in principle to that I have just explained. In the method I am about to describe, hydrogen still performs the function of a reducing agent, but the final result is pure, bright, and solid silver.

It is well known that most substances burning readily contain a large proportion of hydrogen, such are naphtha (liquid), paraffin (solid), asphaltum (solid), and resin from turpentine. The two latter will suit our purpose best, being easily reduced to powder. Proceed as follows:—

1st. Let the chloride of silver be well washed, by pouring on successive changes of water, to rid it of soluble matters; then pour on a filter to drain, and, finally, well dry and powder fine.

2nd. Take two ounces of this fine powder, and one ounce of finely powdered asphaltum or resin, mix them intimately; passing through a tolerably fine sieve twice does the work well.

3rd. Have ready a good smooth assay melting crucible,* which may be filled nearly full, as there is no boiling over to be feared, as, with the ordinary processes at first, apply a gradual heat. A portion of the decomposed hydrocarbon not taken up or in excess of the chloride will burn on the top, so no fear may be entertained from its appearance. It may now be placed in the most intense part of the fire, and about two drachms of powdered calcined borax is then sprinkled on the mass. When it has lost the appearance of powder, press the mass down round the sides with a stick of wood, consolidate the fire (of coke), in which the crucible must be immersed to the top, on which place a large piece of hard coke and keep at a white heat, from ten to fifteen minutes, when you may expect the operation to be completed. The silver will be found in a button on breaking the crucible, when cold, or it can be poured out and the crucible preserved for another operation.

In conclusion, a few words on the management of the fire and stove in ordinary use best suited for the purpose may be acceptable. The coke should be chosen of a medium density. Do not use the soft, black kind. Break it in pieces about the size of a hen's egg. Before placing the crucible finally, have the grate three or four inches deep, of a good, solid, bright fire; then pack round the crucible, closely, smaller pieces of coke, bed up to the mouth, and cover, as before mentioned, with a good piece of coke. Keep the grate clear from the bottom, removing the ashes by gently raking now and then, that the current of air may not be impeded.

Of stoves, the round, close wrought-iron ones are first to

* Should any difficulty be experienced in procuring good, smooth crucibles in the country, Mr. F. W. Hart informs us that he will be happy to supply them to provincial photographers.

be chosen, as in them sufficient heat can generally be obtained to melt 3 or 4 ounces, without the aid of blowing. In the small American Queen Stove, now much used in photographic rooms, can be melted between 2 and 3 ounces by gentle application of blowing—the top doors slid close. If an ordinary fire-place be used, choose one where the fire is at least eight inches in any direction.

[Mr. Hart, at our request, made an experiment, for the purpose of testing the completeness of the return of silver obtained by this method. A small sample of chloride was carefully analyzed by means of his Volumetric Apparatus, and found to contain a per centage of 60% of metallic silver. Of the same sample of chloride, 45 grammes were then taken, and reduced as above described, and gave a button of pure silver weighing 60 per cent. of the original amount of chloride, besides a few small beads adhering to the crucible. This was effected by exposure for about a quarter of an hour to the heat of a small furnace, without artificial draught.—Ed.]

ON THE STRENGTHENING OF COLLODION NEGATIVES.

BY M. MC A. GAUDIN.

IT is the opinion of most chemists that negatives on collodion are formed of particles of reduced silver in a state of infinite division, which are lodged in a network, or kind of spongy body, formed of collodion rendered insoluble. It is quite certain that every particle of the silver formed by the reducing agents is external on the substance of the collodion, for unless it were so, it could not be formed; and it is evident, that in a picture on collodion there are two superimposed layers; the one below, composed almost entirely of spongy collodion, and the other uppermost, composed at first of iodide of silver, then, after fixing and washing, of a seed plot of reduced silver, which insinuates itself, as it were, in the interstices of the subjacent collodion.

This reduced silver possesses peculiar properties, due, doubtless, to the particles of iodide of silver unattacked by light with which it is united, before the fixing in hyposulphite has caused it to disappear. Whatever it may be, it is certain that in presence of the energetic reducing agents which have produced it, and which are renewed, pyrogallic acid, sulphate of iron, &c., this silver, I repeat, augments its bulk regularly over the entire surface of the picture, and causes the intensifying which is successfully practised now-a-days, whenever the first development does not produce the desired intensity in a picture. Even after fixing, certain salts of iron increase the mass of silver indefinitely, such as, for example, the proto-nitrate of iron, under certain conditions.

I have, for a long time, thought of obtaining intensifying by means of electricity, perceiving in it a means of arriving also at an indefinite increase of the silver already deposited. I made the attempt on several occasions without attaining any success.

The cause of my non-success, and the means by which I succeeded, are as follows.

Forced to reflect upon this singular refusal to take silver, gold, or any other metal, easily reducible by the pile, when metallic contact is well established, in the region of the sky, for example, or the silver is so dense that, upon rubbing with a tuft of cotton this region in a proof well washed and dried, we obtain a highly reflective surface, in some respects, a silver mirror, I said to myself, this surface appears very metallic; it is also almost impervious to light, and this it is which makes it fulfil its function; it allows only a bluish tint to pass, like silver deposited in a very thin film upon glass. Nevertheless, it is not completely opaque, since, in printing, we are obliged, when wishing to obtain perfect whites, to cover this region with a coating wholly impervious to the chemical rays, such as China ink, chromate of lead, &c.; therefore there must be a reason for it, and, in fact, there is only one which is found verified by the knowledge we

have acquired of the texture of photographic proofs;—it is that the metallic body which forms the picture is *disseminated* and not *continuous*; from this, there results centres of action, which are so much the more numerous as the effect of the light has been more intense; but they never *touch* each other, except, perhaps, in an over-exposed or solarized proof.

Upon the discovery of the Daguerreotype, chemists of eminence analyzed the silver pictures, and they concluded, as I have before stated, that Daguerrian pictures were entirely formed of little *isolated* deposits; and when I took up the practice of this wonderful process, I verified this fact myself, by the microscope upon prodigiously sharp pictures obtained with a diaphragm as small as a pin-hole. So then, it is the same with proofs on collodion: the particles of reduced silver are isolated from each other, and if by chance some are in contact, there are here and there some branches starting from a centre around which they radiate. But as every proof is formed of multiplied alternations of light and shade, or what is the same thing, of regions where the silver is thinly spread, but, as a whole, always disseminated with vacant intervals reserved, however small they may be between the metallic particles: it results that the electricity of the pile cannot *circulate* from one to another, as that requires perfect *metallic contact*.

Such, in fact, is the essential condition for the electricity of ordinary piles to transmit its action to the greatest distances; the most powerful tension cannot overcome this condition, which is certainly not met in collodion proofs. But we know two different methods of producing electricity, each of which has its special attraction—static electricity and dynamic electricity: the one produced by friction, the other by chemical action; electricity of tension and electricity of quantity; electricity of induction and direct electricity. That is the latest definition of it.

To arrive at the result, we shall say that there is an electricity which is propagated only by a continuous metallic contact, and an electricity which crosses the metallic discontinuities, when its force is in proportion with the interval which makes the discontinuity. Thus the powerful battery capable of the brilliant well-known electric light can enter into operation only by the *effectual* contact of its poles; but by interposing the Ruhmkoff coil, the spark becomes apt to cross distances of 50 centimetres (20 inches) to one thousandth of a millimetre, according to the power of the battery; like the lightning, which, by means of its vast apparatus, darts its bolts, which are evolved in serpentine form, exactly like those produced by the Ruhmkoff coil. Therefore, what must be done to intensify collodion negatives by the pile? We must combine its elements with a Ruhmkoff coil, and then the electricity will not fail to produce its effect over the entire surface of the proof, as though continuity existed.

In speaking of intensifying pictures by the pile, I do not wish to say that we must substitute this new method of ordinary strengthening a picture for the usual practice; but there is a very interesting case which demands its aid. I speak of instantaneous pictures, which require only the tenth of a second's exposure for small size; and it will be a very great advantage if we can, by intensifying with the pile, operate with half the present exposure only; for it is admitted that the most fugitive proof is perfect at first, and that it arrives at the desired intensity only by a development which is really an intensifying. This is so true, that I have often obtained positive proofs upon glass with sulphate of iron, which, although scarcely visible to the ordinary eye, appear under the microscope models of ideal perfection. If I do not deceive myself, these proofs were susceptible of being strengthened by the pile, according to the method I have suggested to physicists, who have suitable apparatus at their disposal, and can bring this delicate operation to a good issue, which requires a piece of good leaf to be placed on the edge of the glass plate, so as to connect with the picture, and the application of a small piece of silver upon the gold leaf.—*La Lumière.*

CHILDREN'S PICTURES.*

I AM an amateur in photography in a small way, and read the Journal, of course. Many a difficulty have I mastered by its aid. But now help is wanted, not for me alone, but for a suffering profession. Hear the case.

Convenient to me is the thriving town of B, which boasts of three photographers. Good fellows, all of them; know a thing or two, and can take a hint or a picture in reasonable time. When in town, I always look in upon them, to chat a little on art matters, and compare our work.

A few days since I walked in friend A's pleasant rooms. A is a spruce young laddie, very civil and obliging, and always balmy as a May morning to his lady customers. I found him in his dark room, rather nervous. "Fact is, Sam, I have about a dozen babies, more or less, to take this morning;" and an occasional squall from the reception room confirmed his words. A urged me to stay a little while, and I stayed.

Baby No. 1 came in accompanied by pa, who carried the baby; ma, who did the baby talk, and a plenty of it; and two small sisters, who capered and crowed to amuse the darling. Excepting that the baby's head would not keep up any way, and that he would suck his thumb, or cried if that favour was denied him, he wasn't a bad sitter. But these trifling drawbacks consumed an hour or so, and baby was only caught at last when in the act of dropping to sleep, his head held up by hand, and the countenance decidedly puttyish. Ma was dissatisfied, but pa was in a hurry, and A strained his conscience, affirming that the picture was very good. After some vain attempts to beat down prices, the party left, making room for an interesting pair of twins, whereon I fled despairingly.

Friend B is a man of few words, and those brief, like Pat's owl, "he kapes up a dale a' thinkin." I found him trying to take a family group, consisting of a mother, a spoiled three year old boy, and a six months' baby. My friend's countenance was an artistic study, and expressed a variety of contending emotions, prominent among which I could read a desire to shake the spoiled boy, and free his mind to his mother, while a desire to get a customer was fighting hard with his honest indignation. After waiting for half an hour in vain, I left him in his dark closet preparing his ninth plate, and growling something about the malignant abuse of Herod for the slaughter of the innocents.

Friend C is a bachelor of the most straitest sect. Babies and baby talk are to him an abomination. He is in dress, movements, and conversation, a model of sedate propriety. Judge of my surprise, when, on entering his room, and peering cautiously around the screen, I beheld him shaking a child's rattle with might and main, and trying at the same time, to whistle "Pop goes the weasel," with variations. At last off went the cover, but the whistle and rattle ceased, and the baby threw back its head and bellowed; mother hush-a-byed, and C, with a look of desperate resignation, prepared another plate, and resumed his musical labours; but baby refused to attend, and, as I fancied, winked precociously out of his right eye, as if he liked to see the fun. "Can't you try something else, Mr. C," said the anxious parent, and C, after profound meditation, rushed into the closet, extemporised a drum out of a gutta percha 4-4 bath, and by energetic thumping, succeeded in fixing the infant's attention. Cautiously he uncovered, and, warned by previous experience, he redoubled his musical exertions, accompanying them with a kind of war whoop and scalp dance, which would have done credit to any of Barnum's Winnebagoes. The result, I am happy to say, was a very faint picture of a very much astonished urchin with eyes like saucers; but there was a picture, and C sat down exhausted. I offered some ironical congratulations upon his success, but he was too deeply touched. More in sorrow than in anger, he waived the subject, solemnly averring that such labours as these just re-

* *The American Journal of Photography.*

ported were wearing out his very existence, and conjuring me to write the truth above him as an epitaph—

"Died of children's pictures."

Mr. Editor, what is the remedy? Can't a law be passed that children too small, or too ill managed to be spanked into quiet, shall be excluded from operating rooms?

Failing in that, can the Indian fashion of strapping infants to boards, so as to preclude all motions except winking be made popular? Astonishing babies multiply upon us, and unless a remedy is found, worthy photographers will be cut off by untimely fate. Tell us, O Nestor of photographers, what's to be done about it?

New York, Oct. 20th.

B.

PHOTOGRAPHY IN ITS APPLICATION TO MILITARY PURPOSES.

BY JOHN SPILLER, F.C.S.*

Assistant Chemist in the War Department.

THE communication which I have the honour of submitting to your notice this evening will be found to differ somewhat from those usually presented on these occasions, in respect to the absence of novelty, either in the way of chemical processes or in manipulation. Its character is chiefly historical, and its interest will be based upon the circumstance that the applications herein referred to are special in their nature, and though not entirely new, have never, so far as I am aware, been treated of or described at any previous meeting of the Society.

It will be my endeavour to give you a short account of the photographic operations undertaken by a branch of Her Majesty's Service, with which I have the honour to be connected, *viz.*, the War Department; and to describe the origin, and trace the progress of these applications during a period of about six years. Such a narrative, which I trust will possess some features of general interest, will include the description of difficulties met and partially overcome, and will involve many considerations similar to those which present themselves in the daily experience of the professional operator, whether he be devoted to portraiture, landscape, or other well-defined branch of photographic art.

In commencing my historical sketch it is proper to mention and acknowledge the employment of the camera in the Royal Gun Factories during the years 1855 and 1856, when it was first used as a means of portraying the peculiarities of construction involved in sundry schemes for the improvement of ordnance, and the application of the system of breech loading. The late Major Vandeleur, R.A., and Mr. Mac Kinlay, then proof master, worked both the Talbotype and collodion processes, and produced results of interest and value in their Department, but which were not distributed to any extent, in consequence of the limited opportunities available for their production on the part of officers performing other duties of a more pressing nature, and of an entirely different character.

In the summer of 1857 the Officers connected with the Royal Artillery Institution, Woolwich, were desirous of introducing the study of photography, and in September of that year the committee invited me to undertake the Officers' class newly formed, and to give a course of instruction in the principles and practice of the art. The acceptance of this appointment led to the working out of new directions, or rather extended applications of photography, and the camera was frequently employed in the representation of military subjects, in the production of drill pictures, and other illustrations of suggested improvements in the form and use of artillery *matériel*.

Foremost among the officers stationed at Woolwich, who thus appreciated the value of photography, was Lieut.-Colonel W. B. Gardner, R.A., at that time Superintendent of the Royal Military Repository, and it was mainly due to the influence and exertions of this gallant officer that photography so quickly assumed the importance which it has ever since maintained in connection with the War Department. Colonel Gardner succeeded in inaugurating the appointment of photographer to the institution of which he was the head, and in that capacity I commenced service in April 1858, not, however, following this as my sole occupation, but devoting usually one day in the week to the practice of photography, my duties as Assistant Chemist in

the Royal Arsenal not permitting me to give a larger share of time and attention than that already specified. This post was retained by me during three years, at the end of which time the Secretary of State for War determined to extend greatly the operations of the photographic establishment, by appointing a military staff, and placing the entire direction in the hands of the Chemist of the War Department, under whom I continue to superintend the production and general issue of photographs. By this step of centralization, a number of independent branches became absorbed, or united into one General Photographic Establishment, *viz.*:—The Royal Military Repository, Woolwich; the several Manufacturing Departments in the Royal Arsenal; and the School of Gunnery, Shoeburyness.

It is in this place proper to remark that the Topographical Department at Southampton, under the direction of Colonel Sir Henry James, R.E., remains perfectly distinct, its objects being special, and is in no way affected by the amalgamation lately brought about in other branches of the War Office. In a similar manner the photographic establishment at Chatham, so ably superintended by Captain Schaw, R.E., has a separate maintenance and action, although the work performed does not differ widely from that undertaken at Woolwich.

Having thus briefly sketched the origin of our present establishment, it becomes necessary to say a few words about the staff, and to describe the nature of the work itself. At Shoeburyness we are favoured with the assistance of Captain H. J. Alderson, R.A., Superintendent of Experiments at the School of Gunnery, and in this aid we are particularly fortunate, since much of the work executed at that station has special reference to the new systems of attack and defence, and to the registration of the effects produced upon the armour plating, by shot and projectiles of every description. Such results are so satisfactorily recorded by means of photography, that these illustrations have been adopted in the reports presented to Parliament by the Iron Plate Committee. Captain Alderson has attached to him for this duty a staff-sergeant and gunner Royal Artillery, both of whom have received a course of instruction in photography, and now exhibit very considerable aptitude in their work.

Besides the above-mentioned, we have at Woolwich five non-commissioned officers, Royal Artillery, the majority of whom have been instructed by myself. They are engaged in printing from the negatives sent us from Shoeburyness, and from other plates illustrating gun drill, bridging, and military engineering, produced formerly by myself, and at the present time being constantly augmented by additional subjects taken in the grounds of the Royal Military Repository, by Sergeant James Inglis, R.A. An excellent series of mounted guns, store carts, ammunition and ambulance waggons, and a variety of other carriages included in the artillery field train have been photographed on a somewhat large scale by Mr. Henry Butter, Chief Draughtsman in the Royal Carriage Department. The views taken by that gentleman, upon 15 by 12 inch plates, during the progress of experiments upon the battering of the Martello Towers at Eastbourne and Box Hill, are probably inferior to none of their kind.

The character of the work performed at Woolwich has been, to a certain extent, already defined; but it will be worth while enumerating a few more instances in which photography has been usefully applied. The soldier's kit, as laid open for inspection; the uniform and accoutrements worn by different regiments; the harnessed horses composing an artillery team; mulo draughts for mountain travelling; Canadian equipment for conveying guns and military stores in a cold climate; ammunition boxes and modes of packing medicines, and small stores for transmission to distant stations; tents and marquees; camp cooking-apparatus; pontoons and gun rafts; tackle, gins, and other appliances for mounting and dismounting guns, and landing the same from boats; repairing operations shown in stages, such as the rebouching of cast-iron guns, and refacing Armstrong ordnance; burst guns, showing the lines of fracture; modes of repairing disabled gun carriages; portable fire engines; molten iron and hot shot furnaces; war rocket apparatus; construction of earth-works, traverses, rope mantlets and other means of defence; the record of damages caused by accidental explosions, &c., &c.

Some progress has been made also in the delineation of complicated machinery, particularly that used in the manufacture of the Enfield rifle, and of the bullets for the same. Difficulties have, however, been encountered, partly from the want of light in the workshops illuminated only with a northern aspect, and

* Read before the Photographic Society, on the evening of Tuesday, December 1st.

with the glass in the skylights not particularly pale; also, from the great depth of focus rendered necessary by the dimensions of the machine, and often the practical difficulty of getting a clear view, and of retiring with the camera to a sufficient distance. Some of these requirements are identical with those involved in the taking of drill pictures of considerable size; when, for instance, an artillery detachment is grouped far and near around the gun, and some are engaged in the act of loading with heavy shot, or implements in hand, which renders it difficult to remain perfectly steady for more than a few seconds. Under these circumstances, the optician will recognize a certain degree of difficulty in so accommodating the lens as to take the entire group with rapidity and tolerably uniform definition. A lens well adapted for this kind of work has been recently prepared for us by Mr. Dallmeyer. It is a single objective of four inches diameter, and about eighteen inches focus, and may be used with a one-and-a-half-inch stop. The aplanatic lens of Mr. Grubb, of Dublin, appears likewise to answer well for these purposes. In cases where a larger exposure is possible, the "triple-achromatic" of Dallmeyer has given us great satisfaction, and with this lens there is no difficulty in getting both the foreground and distance well defined.

Correspondence.

FOREIGN SCIENCE.

[FROM OUR SPECIAL CORRESPONDENT.]

Paris, December 9th, 1863.

At the last meeting of our Photographic Society, the following letter from M. Marion was read:—

I have the honour of submitting to the *Société Française de Photographie* a new process for printing positives without salts of silver or gold, the sensitive agents of which are the red prussiate of potassa and citrate of iron combined. The invention of this process is due to M. Motileff; but certain modifications we have made in the preparation of the paper render it, we believe, more sensitive. To obtain brilliancy in the albumen, we have worked in concert with M. Motileff. We place at the disposal of the members of the society present at the meeting some samples of this paper, that they may experiment on the process and afterwards give their opinion upon it.

This paper is exposed in a printing-frame under a negative for 30 or 40 minutes in the sun, and after being satisfied that the proof is sufficiently strong, it is washed in ordinary water, and the operation is concluded; the picture, which, on being removed from the printing-frame is sticky, is cleared in the washing from the veil that covers the details, and in a few minutes it acquires the brilliancy and delicacy of tint of the finest Prussian blue, with the lights perfectly pure.

To tone this blue picture a black, it is immersed in an alcoholic solution of caustic potassa, 1 part to 300 parts water. The blue proof must remain in this bath until it becomes yellow, which takes place in one or two minutes. It is then well washed in ordinary water, and then we pour on the yellow picture a small quantity of the following alcoholic solution:—

Alcohol (40°)	100 parts.
Gallic acid	8 "

In a few seconds, we perceive the yellow picture change to inky black, and acquire great vigour; it is then dried without being washed, and is thus both toned and fixed.

I believe that the toning of the blue proof to a black requires to be studied; it demands the attention of all who are engaged in photography, for it contains questions of the greatest interest. First, in the economy of production of the proof, which cannot be denied, and next, the permanency of the pictures, a more delicate question, which cannot be solved until after numerous experiments by a great number of persons, each bringing his tribute of art, knowledge and skill.

M. Leon Vidal, of Marseilles, has completed and will soon publish a work the object of which is to show how the time

of exposure in the camera may at once be ascertained, with a given focal distance, diaphragm, and definite luminous intensity. His aim is to effect an appreciation of the luminous intensity at the moment of operating, and then to calculate, on the basis of this measured intensity, the time of exposure, with a given focal distance and diaphragm.

These calculations are put into a table, giving all the mean durations of the times of exposure in hours, minutes, and seconds, for focal distance, from 1 to 100 centimetres, with diaphragm of 1 millimetre to 20 millimetres in diameter.

This photometric table is calculated on the following basis, verified experimentally:—A simple $\frac{1}{4}$ plate objective, in the best condition of light, requires one minute's exposure upon dry collodion, with a focal distance of ten centimetres ($\frac{1}{4}$ inches), and a diaphragm of 5 millimetres in diameter (one-fifth of an inch). Starting from this basis, and supported on these two laws—1st, that the intensity of light on the unit of surface varies in the inverse ratio of the square of the luminous point from impressed surface; 2nd, that the intensity of light varies in the direct ratio of the square, of the diameter of the diaphragm giving access to the light. M. Vidal has established, mathematically, the time of exposure upon dry or wet collodion, whatever the intensity of the light, always taking into account the diaphragms and local distances employed. These calculations are applicable to every kind of objective, single or double. On this subject, M. Vidal again expresses the wish that opticians and makers of apparatus would mark the focal distances of the lenses on their tubes; upon diaphragms, a number indicating their diameter (in 10ths of an inch), and on the base of the camera and its extension, the graduated metrical distance, starting from the front containing the objective. In this manner a simple inspection would always permit the operator to ascertain under what mechanical conditions he is operating.

The photometer presented by M. Vidal to the Photographic Society of Marseilles, on the 8th of October, 1862, is based upon the colour albumenized paper assumes, by the chemical decomposition of its chloride of silver. The scale of graduation is concentric with a strip of sensitive paper, of which only a portion is exposed to light through an aperture easily uncovered. The graduated scale is composed of ten tones, arranged in such manner that each increases a degree from that obtained in six seconds in the best conditions of light to that obtained in one minute or sixty seconds, so that we thus have the series of tones obtained in from six to sixty seconds. The operation consists in measuring the intensity of the light in the open air, always done in the shadow of the body of the operator, standing with his back to the sun. The duration of this operation is one minute, measured by a sand-glass. It is easy, during the operation, to bring the eye to compare the tones on the exposed paper with those which best correspond with that obtained by the chemical action of the light of the moment. The appreciation is very easy, and if error were possible, it would be only in the series of the last five tones, in which case a hesitation between two consecutive tones would cause but a very slight error, which may be overlooked. The degree of light being known, it becomes easy, table in hand, to deduce from it the time of exposure, the numbers of the table being based upon the No. 10; that is to say, upon the best conditions of light.

CHROMOPHOTOGRAPHY.

SIR,—In No. 273 of your journal, Mr. Busch has criticized unmercifully my little discovery in Chromophotography, regardless of the favourable opinion expressed by some, whose names are of note in the photographic world.*

* 1. "Phio del fotografo," by J. G. Sella, new edit., 1863, page 466:—"Il Colonnello Baratti, per colorare le prove propone l'uso di soluzioni," etc. "Le immagini così trattate quando sono rifrate nell'iposolfite, sono di grande effetto pereré la tinta e gradazione di esse, non e monotona

Has Mr. Busch thoroughly examined that process which he stigmatizes over freely, declaring that it "does certainly not look like a step in advance," and settling that I* "only substitute painting them (*the photographic images*) over with colours," which latter process, he is "afraid, is decidedly the better?" Evidently, Mr. Busch does not know that, in condemning my chromophotography, he speaks against his own interests, otherwise he would not drive the photographers to the abolition of the toning process, he who is a manufacturer of chloride of gold, if I mistake not. Hence Mr. B. ought to know very well that the solution of this salt is colourless, and therefore you cannot *paint* with it, though you may tone with it; and, as a chemist—even if he has not read the theory of toning by Messrs. Davanne and Girard, now publishing in your journal—he ought to know that the tint produced by gold is effected by substitution—"a portion of gold is deposited, a portion of silver is dissolved, and gives place to the gold." Consequently the image preserves all its original purity, while water or oil colouring, which he is afraid is decidedly the better," is a process of superposition, which covers the photograph with colouring matter extraneous to the sun printing, and debases the exquisite merit of truth, hides the delicate lines of the picture, seeks to trick you into believing it to be the wonderful effect of chemicals and light, when it is nothing but an abortion that is not worthy the name of a picture or a photograph.

If Mr. Busch is contented with this sort of hybrid production, let him enjoy a satisfaction I cannot envy him. And, in fine, as Mr. Busch modestly reserves to himself, in his quality of chemist, the privilege of solving the problem of photography in colours, excluding from such studies all us ignorant photographers. We wish him full success in his researches; and if, after a long and painful incubation, should they give birth to a little mouse, still it will be a mouse, and we will never say that "it does not look as a step in advance."—Yours,

L. COLONEL C. BARATTI.

Milan, 6th December, 1863.

Photographic Notes and Queries.

COLOURED PHOTOGRAPHS, OR DOUBLE TONING.

DEAR SIR,—I noticed in your last impression Signor Rizzo's and Colonel Baratti's dispute of priority on colouring photographs by toning process. I trust that I may be allowed to remark that the invention (as it is called in Galignani's), is not a *new discovery*, inasmuch as any one who has been familiar only for a short time with photo-toning, must surely have noticed the different hues obtained by the various degrees of toning, and fixing with or without toning, by hypo, ammonia, &c., &c. The novelty, however, might consist in the application; but this, too, is misunderstood; and at all events, of no practical use.

No doubt we may tone the face one colour, the coat of another, and so on, but it will always represent the portrait of some one afflicted with yellow or other fever. There is nothing more difficult to render truly as in nature, than the blooming complexion of a fair lady in all its delicacies of light and shades. How, then, could a manipulator, however skilful he might be, produce softness and vigour, almost on the same spot; insensible gradation and variation of tints; minute sharp touches of shade, outlines neat and true, and solve many other artistic difficulties by means of a bath or solution? Moreover, if we have to use the brush in toning, it will be far better to use it comfortably, with the aid of stick and easel, in plenty of white light, when the artist can mix, judge and alter the pigments at his own fashion and fancy, better than in the yellow or gas light. Last year I tried more than once to utilize such a method of fancy toning, but as my time is not my own, it was not until last spring that I succeeded to something worth mentioning. In the

ma, vario e conveniente. I ritratti guadagnano maggior vita quando, vengono trattati con questo metodo."

* See a letter on the same subject in the *Camera Oscura*, page 143.

3. Vid Ind., page 178, etc.

* I do not say *our*, because I alone have published the process in question, and the *Galignani* took his quotation from an article of mine in the *Camera Oscura*, and the public and myself are, as yet, ignorant of any other publication of that kind.

usual gold solution, I toned a whole-plate portrait of the Princess Alexandra, with the only difference that I made the hair of a *rich fox hue*, and the ribbon binding it behind of a *pinkish tint*. Again, a whole plate portrait of Lydia Thompson, the hair of a *decided golden colour*, and the coronet of a *rich velvety true purple*. I was pleased with it, and I named it *double toning*, from its relation, double printing, and showed those and few similar experiments to my principal, but as it was not a question of L. s. d. to him, it was there and then condemned as losing time in playful nonsense. Although my friends admired very much the pleasing contrasts of double toning, yet I could not see in it any practical use. Lately, however, I found out its application, and very beautiful it is too. If landscape views are toned gradually from very cold to very warm tones, a skilful manipulator may produce such effects that no artistic brush or crayon work can compete with. There you can obtain the true effect of sunrise and sunset; you can represent the effect of a conflagration; and many other very beautiful artistic contrasts can be managed. The enclosed I venture will give you an idea of what I mean, and although very poor, imperfect and bad proof, yet you will be able to judge that the application is true, and of the vast new field, which is opened to photo amateurs to show their artistic feeling. I shall be thankful of your opinion thereon. Apologising for trespassing on your valuable space,—I am, dear Sir, faithfully yours,

P. T. COZZO.

[The question is, will the results to be obtained be commensurate with the trouble? Doubtless the process may occasionally find useful application, and we have seen some pretty effects.—Ed.]

MEASURE OF THE ANGLE, &c.

SIR,—I have seen a good deal of correspondence lately in the PHOTOGRAPHIC NEWS concerning the angle included in various lenses. Surely there is nothing more simple than to get the correct angle of a lens with the prismatic compass, which I have always used for that purpose. I follow the simple plan of placing the prismatic compass on the top of my camera; when requiring the angle contained by the lens, I focus sharp (as near the left edge of the focussing glass as possible) some conspicuous building, such as a church. I then take the bearings of the church, or building, and then, having marked some point (probably a tree) which is perfectly sharp on the right-hand side of the ground glass, I take the bearings of that. I then deduct the number of degrees of one from the other, and the result is, I imagine, the correct angle contained by the lens.

I have used your chloride of lime toning bath with great success. I found adding a few grains of acetate of soda an improvement.—I am, sir, your obedient servant,

H. DUBERLY, Major 8th Hussars.

Simla, East Indies, October 1st, 1863.

[To obtain certainty by this method, it is necessary that the compass be in contact with the optical centre of the lens. With the triple the place of the stop is near enough.

NITRATE OF SODA IN THE PRINTING BATH.

SIR,—As a photographer, I have for a considerable time felt great interest in the discussions now going on in various photographic societies, on the strength of floating bath necessary to secure the best and most uniform results in printing. Professionals and amateurs are alike at their wit's end, by the very opposite results arrived at by different persons, using even the same formulæ; this is particularly the case in using nitrate of soda; one gets prints of unsurpassed brilliance on an 80-gr. soda, and 30 or 40 grs. silver, while another, (to wit, "Cantab," in last week's News) finds that, with the same materials, and in similar quantities, *his albumen is dissolved from the paper!* Now the experience of "Cantab" exactly corresponds with my own. Being anxious to try the soda nitrate bath, I added 30 grs. of that material to a 40-gr. bath. On floating old albumenized paper on this bath for 4 minutes, I got tolerable prints, but not equal to a 60-gr. bath with 2 minutes' floating. I then tried some new Rive paper, No. 48, when the albumen immediately dissolved off in patches, covering the surface of the bath with transparent froth. Determined not to be done, I added silver to make it up to 80 grs. nitrate silver, still the addition of soda originally made, caused the albumen to dissolve. I then added

as much nitrate of soda as made the quantity up to 80 grs. per oz., and I have never been able to get a print fit to be seen since. The albumen dissolves as before. I added as much nitric acid as yielded a faintly acid reaction, and then found the albumen to remain intact, but the colour of my prints in toning is blue, grey, green, mud, and, in fact, every variety except what a professional can send out. Now, Mr. Editor, what is this "photographer's assistant" to do? If I add nitric acid to my floating bath, it again becomes alkaline in about 60 hours, even if it is not used, and I almost come to the conclusion, that in the practice of our interesting "black art," I must have done something to secure the presence of "his sable majesty," who gratifies his propensities by turning my floating bath into an alkali establishment, or a soap manufactory.

As you have recently published "Jottings by a Photographer's Assistant," which have materially helped me into my present difficulties, you will perhaps now publish this jotting of

ANOTHER PHOTOGRAPHER'S ASSISTANT.

Walton, near Preston, Dec. 7th, 1863.

[Why the tone of our correspondent's prints should become "blue, grey, and green," when nitric acid is added to his bath, we cannot tell, as the legitimate effect of that acid is to keep the tone warm. Neither can we see how his bath should, when so made acid, become alkaline without use.—ED. P.N.]

PHOTOGRAPHY IN A GALE.

SIR.—The view from our house is admirable for artistic and photographic experiments, about fifty yards from the sea, and opposite Portsmouth and Spithead. At 1 P.M. on the 3rd, when the gale was raging at its greatest power, the wind about 65 miles an hour, I brought my No. 4 triple lens to bear upon the brilliant and boisterous scene.

I am glad to say I obtained a capital negative in fifteen seconds, No. 1 stop, on a 12×10 plate, a 40-grain bath, and Ponting's bromo-iodized collodion. Of course, the sun was shining magnificently, producing as clear and vivid an image on the focussing glass as in a summer's day.

I also tried a plate sensitized and preserved fourteen hours, by Blanchard's honey process. I obtained a good negative in three-quarters of a minute. The tone of the darkest parts, a coppery red, and of the sky, bluish green.—I am, sir, yours truly,

H. KIRWAN ROBINSON,

Capt. 5th Royal Lancashire Regt., late 4th Foot.

Clyde House, Ryde, I.W., Dec. 7. 1863.

AUTOMATIC WASHING APPARATUS.

SIR,—On reading the description of an automatic washing apparatus, by Mr. C. Hanbury, in the last number of the NEWS, I find it is identical in principle, and nearly so in construction, with one which I contrived myself about three years since, but which I have never yet put in practice on any considerable scale. As the method appears, from the description given, to answer, I am induced to mention an arrangement which formed part of my own apparatus, viz.—The addition of two rollers, made either of lignum vite, or loaded, for the purpose of giving them sufficient weight. The rollers being set in a frame which connects them together, pass over the piles of prints in the two halves of the rocking trough, alternately, each in its own division, and, by their pressure, squeeze out the solution from the pores of the paper, ready for the absorption of the next portion of water. These rollers, it will be seen, fulfil also the office of the bullets described by Mr. Hanbury, and are, in a self-acting form, intended to carry out the rolling principle of washing proposed some time ago. In my arrangement, the prints were put between sheets of thin gutta-percha, which, when released from the weight of the roller, float and allow the prints to be freely soaked again by the next supply of water. Should you consider this of any interest to your readers, it is quite at your service.—I am, dear sir, yours truly,

Dec. 8, 1863.

CHARLES W. SMART.

Talk in the Studio.

NEW PHASES OF PHOTOGRAPHY.—We observe a new method of rewarding labourers, which must be after Mr. Disraeli's own heart; it is so ostentatious and ineffectual! "Some country

magnates have conceived the idea of having a book of photographs of all the oldest workmen employed on their estates." It is quite worthy of the brilliant agriculturist intellect of the country, to work labourers like horses and then put their cartes before them as the reward of merit!—Fun.

HIGHLY COMPLIMENTARY.—A gentleman—it might have been the writer of this paragraph—felt very uncomfortable a week or so ago when, on going to sit for his photograph, he was asked by the artist, who was by no means "happy" in the pronunciation of some of his words, whether he wished to have his "fool-face" taken.—Fun.

A CURIOUS PICTURE GALLERY.—A correspondent of *Notes and Queries* writes: "In the *Critic* for Nov. 15, 1852, is the following statement: 'The *Revue Geneve* states that the Federal Council has authorized the Department of Justice and Police to incur the charge of photographing the portraits of persons breaking the laws by mendicancy in cantons where they have no settlement. It has been found that the verbal descriptions hitherto relied on are insufficient to the identification of the offenders.' What a curious picture gallery the police will ultimately form, if this system is carried out!"

"CURED" PHOTOGRAPHS.—A correspondent in the country sends us a curious specimen of photographic advertising, in the shape of a peripatetic photographer's handbill. Our correspondent would be glad to know, if any reader can inform him, what step is taken to cure photographs, as referred to in the following paragraph: "The advertiser's photographs will, he thinks, meet with the approbation of his visitors, his photographs being properly cured and varnished, and warranted to keep well. A trial will convince that Mr. T. uses none but the best Parisian apparatus, combined with a thorough knowledge of photographic chemistry, and wishes to draw attention to his coloured portraits, which are fair and lifelike, the lights and shades being developed."

WIDNALL'S MOUNTING MACHINE.—This is an exceedingly clever and ingenious invention for assisting in the rapid, exact, and neat mounting of photographs. It consists, in the first place, of a box about 10 inches by 9 inches, and 3 inches deep, containing the complete apparatus. When opened, the lid is found to be lined with a slate, upon which the starch or other adhesive material is spread, and what a printer would term, "distributed" by means of a roller, which is also used to apply the paste to the print. In the box itself is the mounting machine. Upon a frame, provided with moveable guides, the card is placed; upon a small block, just the proper size, the print is placed, face down. An ingenious system of rollers, springs, &c., are now brought into play by a touch, the result of which is that the print is held firm by four small clips, like delicate little fingers. The roller, with paste, is now passed over the print; the frame containing the card is then turned over, and falls exactly on the print in proper position. Another touch releases the clips; the frame is lifted, and the card, with the print duly attached, is removed. Rolling with a clean, dry roller, to perfect the contact and expel the air bubbles, completes the operation, which is very much shorter and simpler in practice than in description. The rapidity and neatness of the operation, and the compactness of the apparatus will recommend it to all photographers, but especially to amateurs.

IMPROVED DARK BOX.—We were recently favoured by Mr. R. H. Michell, of Cardiff, with a sight of a dark box, which contained some very excellent points. In general construction it very much resembled Mr. Blanchard's developing box, recently described in our pages, but with certain differences. One of the first consists in a mask or eye-piece fitting to the upper part of the face, fixed to the box where the usual yellow glass is, so that when the operator is at work he looks at his plate direct without yellow glass, his face effectually keeping out the light. A sliding door closes the aperture, when not in use. The glass which admits yellow light into the box at the top, is covered, whilst travelling, with a flap, which, opening back with a hinge, makes increased table room at the top when at work. The interior is so contrived by grooves and turn buttons, that, when packed, everything fits and remains in its place, and the box may be turned in any position without risk to the bottles. The complete equipment fits inside, camera, lenses, and everything; and the whole, with stand, weighs 28 lbs. The calico part of the box containing the sleeves is fitted on to a moveable frame, which is taken out at will, to work freely in the box, when darkness is not required. The box fits on to the tripod very cleverly and

simply. The tripod head is a large triangular piece of wood; at the bottom of the box is a triangular frame, exactly fitting the tripod head, on to which it slides. A strap, which forms part of the fastening of the box, is then buckled round, and holds all firm. There are several other clever little contrivances.

THE OLD PHOTOGRAPHS.—The *Birmingham Daily Post*, commenting on the evidence of the alleged photographs of the 18th century, says:—"Once more we call attention to the fact that a large collection of the papers, working models, and machinery devised by James Watt still remains in dishonourable dust at Heathfield Hall. As this important light on the history of photography has come from a mass of old papers and rubbish of the Boulton family, it is most probable that some further important details might be procured from a careful examination of the treasures still remaining at James Watt's house." It further adds:—"What further revelations this romance of photography may disclose, it would be premature to speculate; but already there seems to be ample evidence that the vaunted discovery of Daguerre and Niepce was practised in our own town more than half a century before. As this subject has so great a local interest, we intend to publish a summary of the very important documents lately published in the *Photographic News*, and in which the curious details of these remarkable discoveries are fully described.

To Correspondents.

F. G.—Members of the Photographic Society will have the first claim to space for exhibition, and will be exempt from charge. Non-members will be permitted to exhibit on payment of a small rent charge for space, &c.

NORTH, W.—The design is very good, but would be better with the glass to the ground. If you have space, the room will be better if 10 feet longer and 6 feet wider. See an article in our forthcoming ALMANAC, with several designs and much information on glass-houses. 2. So far as we know, all the samples of collodion you mention are good; perhaps we should give No. 3 the preference. 3. See remarks on pinholes in article on the management of the nitrate bath in the present number.

THOMAS LEWIS.—Mr. C. E. Elliott's address is Aldermanbury Postern. We believe you will generally find it in our advertising columns. We do not know of any inconvenience in the use of the dark box from moisture dimming the yellow glass. We have not used it ourselves, but we know that Mr. Blanchard has used it for producing many hundreds of very perfect negatives. He informed us that he recently took it out in Brighton, taking 12 clean plates with him, and returned very shortly with 12 of the best instantaneous negatives he has produced, not one plate a failure. From this we infer that the manipulating facilities of the box must be tolerably perfect. 2. So far as our experience and information go, No. 1 decidedly. Consult him as to what will best suit your purpose.

P. HENDERSON.—Various accounts of recent methods of silvering glass for reflectors have appeared in our pages; you will find one on p. 530 of the present volume. We have not heard further from the Editor of the *Electrician* on the cheap battery referred to, but will communicate with him. Mr. Busch, whose address will be found in our advertising columns, will doubtless give you the required information.

FOOTH.—The term over-intensified should generally be used instead of over-developed; the latter term had its origin at a time when the processes of development and intensifying were carried on both at the same time. It means that the intensification has been carried too far, and chalky lights in the print result. Your prints are slightly over-intensified, and consequently want detail in the lights. If you observe the forehead of each figure, especially of No. 2, they lack gradation, presenting a mass of white, without modelling. A little longer exposure, and a little less intensification, would probably have remedied that. 2. In our opinion, No. 1.

CAMERA.—As a general principle, a single lens is better for landscapes than a portrait lens, but if you are content to work with a very small stop, the portrait lens will give good results, and it is probable your quarter-plate lens will give you very good stereo pictures.

J. RAINE.—So far as we can judge from your plan, the design of the glass room is excellent, and we do not see any alteration to suggest. We do not see that a glass room at each end is necessary. See our forthcoming ALMANAC on the subject.

D. W. ABERDEEN, AND OTHERS.—Mr. T. R. Williams informs us, that since our article in a recent number describing his lighting and other studio arrangements, he has been inundated with letters asking for advice in special cases of lighting, for specimens, &c. Having already answered more letters than his convenience should have permitted, he has handed the matter over to us. We would here suggest to our readers, that when a very busy and successful portraitist permits us, for the benefit of our readers, to examine and make public every detail of his working arrangements, it is scarcely fair that he should be troubled with letters from strangers asking him to enter into their special troubles, and give special professional advice. We endeavoured to accurately describe his arrangements, and the principles upon which they are based; the application of these general principles to special cases must be made by individuals. The glass room of "D. W." is quite hopeless, as regards getting anything like similar effects of lighting. With a top light of nine feet wide it will be impossible to cover part and place the sitter so that he practically illuminated with a high side light, as in a room 30 feet wide. Your pictures have too much front light and too little side light; the conditions just require reversing; experiment alone will decide to what extent you can do that. A white screen will reflect more light than a blue one.

P. O.—You will find instructions for taking enlarged negatives in our forthcoming ALMANAC. Your pictures possess some good qualities, but will be improved by a little more care and delicacy in manipulating. Avoid under-exposure and over-intensifying, and observe the works of able men for studies of position, &c. See our ALMANAC on pinholes.

JONAS.—"Medicated spirits of wine" is a term applied to ordinary spirits of wine, with some slight addition by the chemist to justify him in selling it without a spirit licence. 2. It may be used for burning in a lamp; but methylated spirit (which, possibly, you mean) is much cheaper and quite as good for the purpose. 3. It entirely depends upon what addition has been made to it, as to whether it is suitable for photographic purposes. 4. You are guilty of piracy if you make a copy of a copyright engraving for any purpose whatever; but the risk consists chiefly in disposing of the copies. If made merely for your own use, we do not imagine that you would ever be questioned on the subject. The risk you run is that of paying legal penalties. 5. We have occasionally seen a No. 2 B lens and camera for sale, second-hand, but have no connection with such transactions. We must refer you to our advertising columns.

TYRO.—There are very many excellent elementary works on chemistry. That in "Chambers' Educational Course," price 3s., is very useful. "Galloway's First Steps in Chemistry," 5s. As a small work of reference nothing is better than "Fowne's Manual of Chemistry," 12s. 6d.

C. F.—Your bath has, probably, become weak and exhausted with use, and possibly alkaline. Use a stronger bath, and the albumen will not be dissolved.

J. C. CUSTENDALE.—The subject of alkaline development has been fully detailed in various articles in the *Photographic News*. The only mode of dealing with collodion which has tendency to leave the plate, is to use a preliminary coating. We prefer old honey for mixing with the tannin solution.

COLONEL STUART WORTLEY'S GLASS ROOM.—We have had some inquiries for details of the construction of Colonel Stuart Wortley's studio, to which we promised a reply, which the Colonel's absence from town has delayed. We shall give diagrams and description in our next.

J. H. B.—The general plan of your glass room will do, but the side lights should be longer than 4 feet. We should prefer them as long as the top light. 2. The red fog on the shadows during intensifying is not an uncommon trouble, and may arise from several causes too numerous to treat in this column. The free use of citric acid is frequently a remedy. The subject is fully treated in our ALMANAC, and also on page 361 of the NEWS, vol. vi.

ALPHA.—The design of your glass room is excellent; the only alteration we would suggest is 3 or 4 feet additional length, if convenient. You will find a long article on the subject in the forthcoming YEAR BOOK. The mode of warming much depends on circumstances. Hot water pipes are cleanest; a gas stove is also clean; a coke stove next, and, least clean, any kind of stove or fireplace in which coal is burnt.

AN AMATEUR, Lancashire.—We have had no experience with the lens in question.

SODIUM.—Add the carbonate of soda, drop by drop, towards the end of the reaction, and notice if a precipitate is formed after each addition. Where no more turbidity is produced, add a few drops extra, and boil. Filter, and finally purify the iodide of sodium by crystallization. We believe you may obtain it of Hopkin and Williams, and probably of various other manufacturers of photographic chemicals.

J. GILBERT.—We do not know the address of any manufacturer of protosulphate of iron, but that of Mr. Barnes, of Walker, near Newcastle, at whose establishment it was stated, at the last meeting of the British Association, 2,000 tons are manufactured annually. 2. Almost all manufacturers of photographic chemicals prepare iodide and bromide of ammonium, but we cannot tell you the largest maker.

C. W. G.—We shall be at the office on Thursday, any time after 2 P.M. The three first days of the week, we are generally at our residence, 18, Canouber Park South, N.

W. D. B.—We do not know of any patent you will infringe by taking photographs on opal glass. To get transparencies on such glass to look well by reflected light, it is very important not to over-expose them, to use plenty of citric acid in the developer, and then to tone them by some method. Chloride of gold may be used, or bichloride of mercury, followed by a very dilute solution of ammonia. They may be produced by the wet process, following the method employed for lantern slides. Mr. Blanchard describes his method in our forthcoming ALMANAC. 2. In the formula to which you refer, there is, we think, too much chloride of lime; from one to two grains to each grain of chloride of gold are generally sufficient. We should be glad to hear of your formula.

ALPHA.—The tones of your prints are not such pure blacks as we see obtained with the lime bath. We do not apprehend that your bath will keep after the addition of carbonate of soda. It is not perfectly safe nor desirable to neglect washing before toning.

Several Correspondents in our next.

Photographs Registered during the Past Week.

MR. THOMAS TULEY, 23, Trinity Street, Bristol,
Three Photographs of H. M. Robinson, Esq., and a favourite Horse.

MESSERS. WHITE AND HAWKEN, Lostwithiel,
Photograph of the Rev. A. D. Cope.

MR. W. H. BARTON, 26, Triangle, Clifton,
Two Photographs of Lewis, Canon, Maes.

MR. GILBERT CUMMING, 108, West George Street, Glasgow,
Two Photographs from a Bust by John Mossman, Sculptor, of the Rev. Dr. Norman Macleod.

MR. A. S. WATSON, 2, Regent Road, Great Yarmouth,
Two Photographs of Mrs. Overman.

MR. J. FOOTE, 8, Broad Street, Bath,
Two Photographs of Lacock Abbey, Wilts, the Seat of Fox Talbot, Esq.

MR. PETER LOW, 74, Jamaica Street, Glasgow,
Photograph of the Rev. Jos. Ross, Ardreshaig.

THE PHOTOGRAPHIC NEWS.

Vol. VII. No. 276.—December 18, 1863.

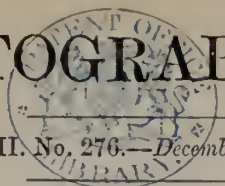

CONTENTS.

	PAGE
A Hint on Double Printing.....	601
Infringement of Copyright in Photographs.....	601
The Tannin Process: Is it slow or rapid? By Josh. S. Hurst ...	602
Colonel Stuart Wortley's Studio.....	603
Alphonse De Brebisson's Treatise on Instantaneous Dry Collodion. By M. Ernest Saint Edme	603
Photographic Chemicals	604
Photography in its Application to Military Purposes. By John Spiller, F.C.S.	605
Glass Rooms, and Lighting the Sitter. By W. B. Parker.....	606

	PAGE
Glass Rooms. By A. H. Wall	607
Mounting Photographs. M. H. Kimball's Plan	608
Proceedings of Societies—South London Photographic Society	609
Correspondence—Chromo-photography—The Discoverer of the Photographic Use of Bromine	610
Notes and Queries—Nitrate of Soda in the Printing Bath—Electric Light	610
Talk in the Studio	611
To Correspondents.....	612
Photographs Registered during the past Week.....	612

A HINT ON DOUBLE PRINTING.

THE methods of obtaining various effects by two or more printings on one picture have become very popular, and are largely practised. A vignettted image merging into a grey tint instead of white; the picture confined to an oval rectangular shape, and then surrounded by means of printing, by an imitation of an india tint; a white sky toned down; and various other effects secured by secondary exposures to light have become familiar to most photographers. There is one fact in connection with the subject which is not, however, so well known, and a knowledge of which is important in securing perfect control over the results to be obtained.

Apart from the sizing of the paper, the proportion of albumen, the nature and quantity of the chloride, and the strength and condition of the nitrate bath, there is another circumstance which materially affects the colour of a print, namely, the kind of light in which it is printed. We have before referred to some experiments we have made in this direction. If a print be exposed in direct sunlight it acquires a redder tint than one exposed in diffused light. In toning each, it is easy to bring them each to the same colour; it is merely a question of a little longer toning for the print exposed in direct sunlight. But if a portion of the same print be exposed to direct sunlight, and another portion to diffused light, and then the whole toned together, it will be observed that the difference in colour always remains, the sun-printed portion of the image retaining the warmest tone. We exposed one piece of paper, part to diffused light, part to sunlight, and a third part was exposed to the concentrated light obtained by focussing the sun's rays on the spot with a lens. The last mentioned portion acquired a somewhat foxy colour, allied to orange; the sun-printed portion assumed a chocolate tint, and that exposed to diffused light attained a purple tint. We endeavoured to get in each as nearly as possible the same depth. The tint each part acquired in printing was persistent through all stages, and in the finished print was well marked.

It follows then that perfect unison of tone in double prints may be secured if it be required, by printing the background, or tinting the sky in a light similar to that to which the print was exposed. If a variety of tint be desired, which may be quite consistent with harmony, it may be easily secured. If the background be required warmer than the image, the negative should be placed in diffused light, and the background exposed to sunlight; if, on the contrary, a cool tone be required in the background, and warmth in the image, the latter will be printed in sunlight, and the background in diffused light. The same principle will apply to sunning down a sky. A difference may even be observed between the tint secured by exposing the print direct to light, and exposing it under a glass, which by its green tint slightly retards the action of light.

This general fact, which may be utilized in ordinary double printing, is sometimes troublesome in combination printing, or producing one picture from several negatives. It may

be that the first negative is exposed to direct sunlight, and then there may be nothing but dull weather, without sunshine, for several days. The print thus exposed to various qualities of light during the printing of different negatives, will never turn out harmonious in tone and satisfactory in general effect. Whether it be utilized and made valuable on the one hand, or whether it be guarded against on the other, it is important to note and remember the existence of such a fact in printing.

INFRINGEMENT OF COPYRIGHT IN PHOTOGRAPHS.

A STRONG impression prevails in some quarters that the recent Copyright Act for securing to photographers the sole property in their own productions is less efficient in practice than it ought to be. On various occasions, when cases of piracy, well made out in all respects, have been brought before metropolitan magistrates, there has been, either from judicial misconception or misplaced sympathy, a failure of justice; the cases have been dismissed, or ridiculously small penalties have been awarded, without costs. In either case the aggrieved complainant who has complied with the law in all respects, and put in operation that part of it especially designed for his protection, is saddled with the expenses of his action, and left without remedy. We had recent occasion to comment on a case of this kind decided by Mr. Yardley.

On Tuesday a charge of piracy was heard at Guildhall upon the general merits of which we shall make no comment, as it is likely to come before a higher court for final decision. We shall, however, briefly refer to one or two questions it raises, which are of interest to photographers. We first quote the brief report of the case as it appears in one of the daily papers:—

GUILDHALL.—THE COPYRIGHT OF WORKS OF ART ACT.—*Mr. Thos. Ordish*, a publisher, of Paternoster Row, was summoned before Mr. Alderman Carter, for unlawfully selling fraudulent imitations of certain registered photographs belonging to Messrs. Southwell, the photographers, of Baker Street, Portman Square.

Mr. Greenwell conducted the prosecution; Mr. Poland the defence.

Some preliminary remarks having been made by the learned gentlemen, the first witness called was—

Mr. Wm. Henry Southwell, who said he was a member of the firm of Messrs. Southwell, photographers, of 16 and 22, Baker Street, Portman Square. They were the proprietors of the registered copyright portraits of Miss Lydia Thompson, in a Spanish dress; and Miss Herbert, as Diana, in Endymion. They had not granted licences to anyone, and consequently not to Mr. Ordish, to make or sell the copies produced, which were spurious imitations of the copyrights.

Cross-examined: They claimed the copyright of the portraits, because they took them from the living originals.

Mr. Limbird Sisman, manager to Messrs. Southwell, said he registered the copyrights in question at Stationers' Hall, on the 3rd of October, 1862. On the 23rd of November last he purchased the two colourable imitations of them at the establishment of Messrs. Bickers and Son, of Leicester Square, where they were sold at 5d. each, the price of the original photographs being 1s. 6d. each. They were very good as copies. He afterwards tried to purchase some at Mr. Ordish's shop, but was unable to do so.

Mr. Poland said certainly not, because Mr. Ordish had previously ascertained they were not legal photographs.

Mr. Greenwell alleged an opposite reason, Mr. Sisman having been recognised as Messrs. Southwell's manager by the shopman.

Mr. Bickers, jun., proved that he purchased the two spurious photographs in question of Mr. Ordish. He had known him many years as a highly-respectable tradesman. He bought the photographs, with others, openly and in the ordinary course of trade. There was no concealment, neither did he receive any caution from Mr. Ordish about them.

Mr. Greenwell said that was his case.

Mr. Poland relied upon the respectability of his client, and the manner in which he had acted on learning that he was doing wrong in selling the spurious photographs, as the strongest evidence to prove that he had no knowledge of a subsisting copyright of the portraits he had been selling. That he had withdrawn them from circulation was clear, as Mr. Sisman was himself unable to buy a single copy when desirous of doing so prior to the commencement of these proceedings. In the absence, therefore, of any proof of a guilty knowledge, Mr. Ordish was entitled to have the complaint against him dismissed.

Alderman Carter said he could only come to the conclusion that the defendant had erred through ignorance; and as he did not continue the sale of the spurious photographs after he became aware of their real character, he should not feel justified in convicting a respectable tradesman of such an offence under those circumstances. He therefore dismissed the summons.

Mr. Greenwell asked for a case to enable him to appeal to the Court of Queen's Bench on the question.

Alderman Carter said: Certainly; he should be pleased to have the point argued by a higher court.

The decision here given is not unnaturally very unsatisfactory to the plaintiffs, and to many others who, like them, possess valuable copyrights in published photographs. One correspondent, writing to us on the subject, concludes that if such decisions are possible the Act is a dead letter, and that piracy may become as rife as it was before the passing of the late Act. There is, however, one very cogent reason why such a result will be impossible. The sole ground of exemption from penalties in this case is the conclusion at which the magistrate arrived to the effect that the defendant had no knowledge of the fraudulent character of the pictures he sold, that he erred through ignorance. Without pausing for a moment now to ask how far the plea is justified by facts in this instance, it is quite clear that such a plea will not be available for the same person a second time. The law, therefore, if not penal in this instance, must at least become preventive of further piracy by the same person.

The whole case here turns on the question of guilty knowledge, and will, no doubt, be fully argued before the Court of Queen's Bench. The clause in the Act giving penalties makes a significant distinction on the subject of guilty knowledge. Persons making piratical copies, or causing them to be made, are subject to penalties without any reference to their knowledge of the law, or of the existence of a copyright in the works. They are presumed not to attempt to obtain an interest in a certain existing property until they have ascertained the legality of their act. But persons selling, importing, publishing, or otherwise

distributing pirated copies, are subject to penalties only if they do so "knowing that any such repetition, copy, or other imitation has been unlawfully made." Here a well-known maxim of criminal law is doubtless intended to apply; *actus non facit reum, nisi mens sit rea*. Criminal knowledge and criminal intent are necessary to constitute criminal action. The plea of ignorance, however, even where established, is only available for the seller, not the producer; it cannot be pleaded in any case if sales are continued after warning from the proprietor of the photograph, and can never be available twice for the same person.

THE TANNIN PROCESS: IS IT SLOW OR RAPID?

BY JOSH. S. HURST.

[Referring to the question regarding the rapidity of tannin plates, Col. Stuart Wortley has sent us a practical answer in the shape of a magnificent study of clouds, and some portion of foreground, taken instantaneously on a tannin plate with the triple achromatic lens. Mr. Hurst, who has been very successful with rapid tannin plates, sends the following excellent remarks.]

PERHAPS a few remarks upon the tannin process, as practised by Mr. H. C. Jennings and "G. W. O.," and published in the NEWS of the 4th inst., may not be unacceptable to your readers.

The first thing that strikes one is the vast differences in time of exposure given by the two operators, and the question naturally arises, What is the cause of the difference of sensitiveness of plates prepared by these processes?

Having made many experiments for the purpose of obtaining rapid dry plates, I think I can point out the reason why those prepared by Mr. Jennings are likely to be more sensitive than the others, though of course the two processes cannot be *accurately* compared, because the whole details are not given in either case; for instance, Mr. Jennings does not name the strength of his bath, nor does he say whether it is acid or neutral. "G. W. O." does not give the focus of his lenses, and aperture used.

I will, however, suppose that the baths and lenses are in both cases equal, and pass on to the collodion. In this there is a difference; Mr. Jennings uses bromo-iodized, and "G. W. O." uses Ponting's iodized, mixed with bromo-iodized. Now I have proved by careful experiments, that (with the same exposure), bromo-iodized collodion gives much more detail in tannin plates, than collodion simply iodized, and this agrees with Major Russell's assertion. See the 2nd edition of his book, page 30.

Here, then, is one cause why I should expect to find Mr. Jennings's plates more sensitive than those of "G. W. O."

The next point for consideration is the preservative.

Now, as tannin has an *acid* reaction, it may be supposed that a preservative containing 5 grains to 1 ounce of water would be less likely to impair sensitiveness than one of the strength of 15 grains.

On looking over my note book, I find that on January 7th, 1863, I prepared fourteen dry plates with various preservatives of different strengths; these were exposed in the same camera under precisely similar conditions of light (having been kept until February 21st, to secure a favourable day), and, after comparing the results, I made the following memorandum:—"These experiments seem to show that a stronger solution of tannin than 5 grains tends to make the film more insensitve, probably from the acidity of tannin."—Major Russell says, "a strong solution slightly diminishes sensitiveness," page 53.

Here, then, is another reason why Mr. Jennings's plates may be expected to be the most sensitive.

We now come to the developers. "G. W. O." uses 3 drachms of a solution of pyrogallie acid, strength $1\frac{1}{2}$ grains to 1 ounce of water, mixed with from 10 to 20 minims of a solution containing 20 grains of nitrate of silver, and 20 grains

of citric acid in 1 ounce water. Mr. Jennings uses a 10-grain solution of pyro (without either silver or retarding acid), until the details are well out. Here, then, is a vast difference; 10 grains of pyro without acid, against 1½ grains with acid, there cannot be a doubt which is the most powerful developer, and this of course is (in the result produced), tantamount to an increase of sensitiveness in the plate.

The requirements requisite for short exposures with tannin plates seem to be a neutral bath; bromo iodized collodion; as weak a solution of tannin as will give sufficient intensity with the sample of collodion used, and a powerful developer.

Mirfield, December 12.

COLONEL STUART WORTLEY'S STUDIO.

In answer to several inquiries, we have been courteously furnished by Col. Stuart Wortley with a ground plan and elevation of his recently erected glass-room, and we add a few particulars of its construction. On reference to the subjoined ground plan, it may be seen that the total length

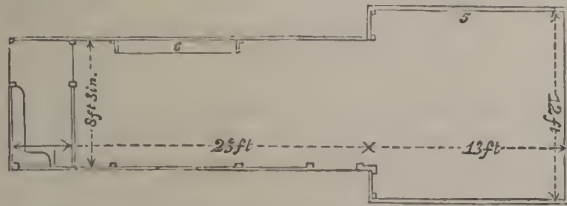

of the room is thirty-six feet, the portion really constituting the studio, the only part lighted, is twelve feet wide by thirteen feet long. The unlighted portion, in which the camera stands, is twenty-three feet long by eight feet wide, and the extreme end is divided off to form the dark room. The part marked 6 has a tier of shelves for various purposes.

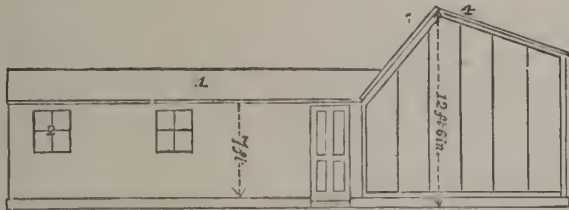

On reference to the sketch of the elevation it will be seen that the studio portion is 12 feet high at the ridge. One side of the studio is all glass, consisting of corrugated glass from the ground to 7 feet high, and from thence to the roof clear white glass. The sloping front light (7) is clear white glass. The opposite side of the studio is opaque, reflected light only being obtained on that side. The roof (4) is also opaque. The only portions having glass are one side of the square or studio portion, and the front sloping portion of the roof (7). With the exception of the glazed parts we have named, the room is chiefly constructed of inch boarding, covered at the roof with asphalt felt. The unilluminated portion is 7 feet high to the eaves and from thence to the ridge about two feet more. The window marked 2 is of orange glass for the dark room. The other small window is to admit a little light when necessary to the unilluminated portion of the room. Each pane in the studio has a distinct set of two blinds, one white and the other black, and the blinds of each pane may each be worked quite independent of the other, so as to secure entire control of the light.

The room is well built throughout and carefully finished in every part, making an excellent smoking room when not used as an amateur studio. The total cost of the erection was £113.

Col. Stuart Wortley informs us that he will have pleasure

in furnishing further particulars to any gentleman who may require them; either through the Photographic News, or, in answer to letters addressed to him direct, at the Carlton Club, Pall Mall.

ALPHONSE DE BREBISSEON'S TREATISE ON INSTANTANEOUS DRY COLLODION.

BY M. ERNEST SAINT EDMÉ.

The great desideratum in photography is a collodion that will dry upon the plate, by means of which we can operate anywhere and at any moment, its sensibility diminishing only with time, although the collodion exists upon the plate only in the dry state. This question possesses sufficient importance to tempt operators to undertake difficult researches in order to obtain its satisfactory solution.

Hitherto we have only succeeded in preserving iodide of silver dry, by removing every trace of free nitrate of silver from the saline films deposited on the plate; but the film of iodide that remains is so parchmented and horny, that it is almost impervious to light and to the developing agents, consequently its sensibility is entirely exhausted. M. Belloc, in one of his treatises, states that dry collodion with tannin is superior to any other hitherto proposed. M. Brebisson devotes a special study to this important question, and we extract from his treatise the principal conclusions at which he has arrived.

Photographers have so busied themselves with the sensitive substances offered by chemistry, that it is almost impossible to present a preparation of any sensitive collodion the efficacy of which shall be due to new products. The discovery of an instantaneous collodion, particularly in the dry state, has always vividly excited the interest of operators; to what substances have they not had recourse to excite this sensibility? Iodide of ammonium, iodide of arsenic, chloroform, aldehyde, the bromides . . . have all been tried. The greater or lesser rapidity in the sensibility depends, we think, upon a concordance, more or less perfect, in the composition of the different baths employed. Instantaneity is, then, a resulting, and not the result, of simple action.

The process described by M. de Brebisson, in his treatise, rests upon the same bases as that of Major Russell, improved by Mr. England. The author has merely modified the preparations, the object of which is to preserve the collodion, dried upon the plate, in its original sensibility; and he says that he has arrived at so short an exposure, that it may be regarded as truly instantaneous.

The author shares our own views when he states that he has not sought to employ new substances, but only to bring the old ones into the most favourable conditions. This new method will not, therefore, augment the photographic pharmacopœa, already too bulky.

We will now proceed to examine this new method in its various phases.

Composition of the Collodion.—It is above all things necessary to have a very sensitive collodion, that works well, as the phrase goes. It may be employed according to various formulæ; for every collodion suitable for the wet process, will be equally so with tannin or pyrogallic acid. Only, the sensibility will be different, according to the proportions of iodine and bromine. M. de Brebisson prefers the following collodion, on account of its sensibility, as well as for its constancy and easy preservation:—

Sulphuric ether at 60°	300 parts
Alcohol at 40°	75 "
Pyroxyline	4 "

To 100 parts of this collodion, become limpid by long standing, add 15 to 20 parts of the following sensitizing solution:—

Alcohol at 40°	100 parts
Iodide of cadmium	10 "
Bromide of cadmium	2 "

Sensitizing.—The collodion being poured on to the plate, and a certain amount of evaporation having taken place, it is sensitized in a bath formed of 7 to 10 parts of nitrate of silver, dissolved in 100 parts of water, with the addition of 5 parts of crystallizable acetic acid.

Washing.—The object of this operation is to remove the free nitrate of silver remaining on the surface of the collodion. If the washing is not complete, the sensitized plate will not keep very long, and spots appear on the collodion film, especially at the moment of the appearance of the picture, sometimes even sooner. A collodion plate, sensitized, and properly washed, and consequently deprived of free nitrate of silver, should, if kept from light and moisture, keep at least two months.

Preserving Coating.—Major Russell employs an aqueous solution of tannin to coat the well-washed collodion film, so as to preserve its sensitiveness after drying. The newer the collodion, the thicker the coating of tannin must be. Mr. England proposes to add honey to this tannin solution. After studying the influence of sugary matters upon collodion, M. de Brebisson prefers to replace them by solid substances, the quantities of which are perfectly known, therefore he employs with much success, barley sugar and jujube paste. He has also recognized, in wishing to recur to gum arabic to increase the solidity of the preserving solution, that this substance possesses the faculty of increasing the sensibility of collodion, and securing its keeping. Once this coating becomes dry, to avoid blisters and cracks, when it softens at the time the picture appears, it suffices to fix the borders by means of a solution of white wax in benzole. This precaution is however, unnecessary, if we replace the honey by jujube paste or barley sugar.

Among the various formulæ for preserving solutions, indicated by the author in his treatise, we extract two, into the composition of one of which tannin enters, and not into the other.

1. Distilled water	90 parts
Alcohol, at 30°	10 "
Tannin	2½ "
Barley sugar	2 "
Gum Arabic	6 "
2. Distilled water	90 parts
Alcohol, at 36°	10 "
Jujube paste	3 "
Gum Arabic	5 "

Exposure in the Camera.—It will be understood that the operation is executed in the usual manner, making use of the ordinary apparatus. Only in the case of an instantaneity, M. Humbert de Molard proposes an apparatus which he calls *Stere-obturator*, or spring shutter-stop. This stop is a sort of blind, of stuff impervious to light, which is extended by means of a spring upon two cylinders placed in front of the objecture. A round hole is cut in the middle of the blind. When the finger is placed upon the spring which governs the fastening, the blind, pulled by one spring, leaves the other spring upon which it was rolled, and for a moment covers the other cylinder. Although this movement of transfer is so rapid that the eye cannot follow it, the aperture in the blind permits the light, during this instantaneous passage, to act upon the sensitized plate contained in the camera. It is by the assistance of this apparatus that M. de Brebisson has controlled the degree of sensibility in his dry collodion to various spaces of time, and, as he states, to have each time obtained as good pictures as if he had made use of wet collodion.

Development of the Picture.—The author asserts, although the contrary has been maintained by eminent practitioners, that this operation may be deferred several days without inconvenience. Still, the certainty of a long keeping after exposure, can never be absolutely attained. Many causes may, in fact, contribute to hasten the reduction, and produce spots—such, for instance, as a sudden elevation of

temperature, imperfect washing especially, and the employment of bad chemicals.

Almost all the baths with an iron base develop the picture quickly, but it is very rarely, says M. de Brebisson, that they are of equal tone throughout, especially when the development is very rapid. These inequalities are due, we think, to an irregular impregnation of the dry collodion. The developing solution of sulphate of iron, acidulated with tartaric acid, as proposed by M. E. Renet, appears to be the most successful.

It is necessary to remark that, in winter, when the temperature of the operating room is rather low, the picture is very slow in making its appearance. It must be accelerated by the aid of heat.

Fixing.—The proofs must be fixed by means of an almost saturated solution of hyposulphite of soda, which must be poured over the surface, until the milky appearance of the collodion film has disappeared, and the cliché has become transparent, without white cloudiness. We next proceed to wash the plate carefully. When the film is dry, apply the protecting varnish.—*Cosmos.*

PHOTOGRAPHIC CHEMICALS :

THEIR MANUFACTURE, ADULTERATION, AND ANALYSIS.

TIN.—This is one of the earliest known metals, and is in many of its compounds of considerable interest. The metal is too well known to require special description here. It occurs in commerce under several forms, the purest varieties being Malacca and Banca tin, and English grain tin. The best tin foil is also pretty pure, although some foil is largely adulterated with other metals. The impurities in commercial tin are arsenic, antimony, bismuth, zinc, lead, iron, and copper. They may be separated by heating tin filings with an excess of nitric acid; this oxidises the metal, and converts it into a white insoluble binoxide. It is well washed with dilute hydrochloric acid, and then reduced to the metallic state by being heated in a charcoal crucible at a bright red heat. In softness, the pure metal is intermediate between gold and lead; it is highly crystalline, and crackles when it is bent. It melts at about 240° C, and boils at a white heat. According to Fridemann, tin may be easily distinguished from other metals to which it is similar, by its behaviour with a solution of gold, containing an excess of hydrochloric acid; a bright surface of tin immersed in such a solution is blackened without evolution of gas; zinc turns black, and liberates gas; lead does not blacken. The most characteristic behaviour of tin is its conversion into binoxide, by the action of nitric acid. Unlike the action of this acid on most other metals nothing is dissolved, but the whole of the tin is converted into a heavy white powder called stannic acid. This is quite insoluble in nitric acid or water, and the reaction is one which is very frequently made use of in the laboratory. If any phosphoric acid is present, it is also retained in the insoluble form by the binoxide of tin, and this fact is frequently used in the estimation of phosphoric acid. Tin and sulphur unite together to form a remarkable golden coloured compound called *aurum musivum* or mosaic gold. The best method of preparing this, is to mix together five parts of protosulphide of tin and eight parts of corrosive sublimate, or to mix a pulverised amalgam of twelve parts of tin, and six of mercury, with seven of sulphur, and six of sal ammoniac. Either of these mixtures is heated in a loosely closed Florence flask, placed in the sand bath. A gentle heat is first applied for some hours; afterwards the heat is raised, but not quite to redness. The greater part of the mosaic gold is found at the bottom of the vessel; the smaller, but purer and finer portion sublimes. Bisulphide of tin prepared in this manner forms gold coloured translucent delicate scales or six-sided laminae unctuous to the touch. Mosaic gold is used in the arts for a bronze powder for touching the edges of painted plaster busts, it is also used by house painters and paper stainers. Tin forms two compounds with chlorine, the protochloride and the bichloride. The former compound, SnCl, is pre-

pared by dissolving pure granulated tin in hydrochloric acid. When no more action takes place, the solution is poured off and evaporated gently until the crystallizing point is arrived at; it is then allowed to cool, and the crystals are separated; they are known in commerce under the name of "salt of tin." This is prepared in enormous quantities for dyeing purposes, the solution being effected on the large scale in copper vessels which are not attacked so long as any portion of the tin remains undissolved.

Protochloride of tin is a very valuable agent for dyers; it is used in calico printing, both as a mordant and a deoxidizing agent. When exposed to the air, chloride of tin absorbs oxygen, forming binoxide and bichloride of tin. Manufacturers prevent this by the addition of chloride of ammonium, which forms a double salt with tin, not so easily oxidizable in the air. Protochloride of tin is of great use in the laboratory for deoxidizing purposes; it is usually dissolved in dilute hydrochloric acid, and when added to solutions of metals reduces them, if possible, to the lowest state of oxidation, or to the metallic state; thus, per-salts of manganese and iron are reduced to the proto-salts, arsenic acid is reduced to arsenious acid; almost all the compounds of mercury are reduced to the metallic state; and silver salts to metallic silver. With gold, protochloride of tin forms a brown or purple precipitate according to circumstances.

Bichloride of tin, SnCl_2 , is prepared by the action of dry chlorine gas on tin foil, or by distilling common salt with persulphate of tin, and rectifying in retorts over oil of vitriol. It forms a thin colourless liquid, boiling at 120°C ., and giving off white fumes in the air at ordinary temperatures. Water unites with anhydrous bichloride of tin with great avidity: with one-third of its weight of water, the liquid solidifies to a colourless mass of crystals, a great deal of heat being evolved, the first portions of water hissing as if they had been poured upon hot iron. The addition of more water dissolves the bichloride of tin, forming a colourless liquid which, when evaporated and cooled, yields deliquescent crystals. This solution is like that of the protochloride, largely used by dyers and calico printers.

Purple of Cassius is a curious compound of tin and gold, the exact composition of it being a matter of some doubt. The best method of forming it is to mix one part of the *liquor ferri muriatici* of the shops, with three parts of water, and a solution of one part crystallized protochloride of tin in six parts of water, added till the mixture acquires a greenish tint, after which six parts more of water are added. On the other hand, some gold is dissolved in hydrochloric acid with gradual addition of nitric acid, excess of acid, especially the latter, being carefully avoided. The solution is diluted so far that 360 parts of the liquid contain only one part of gold, and the tin solution is then added with constant stirring as long as a precipitate is produced. By this process 100 parts of gold yield 360 parts of dried purple. In order to ensure success, it is important that the above proportions be closely adhered to. In the moist state, gold purple is of a dark purple red colour, brown after drying. Whilst moist, it dissolves in aqueous ammonia, forming a deep purple red liquid. When mixed with glass, and melted, the purple imparts a strong ruby colour to it. The analysis of purple of cassius has not yielded good results, owing, no doubt, to the difficulty of obtaining it free from either metallic gold or binoxide of tin. Some chemists consider it a mixture of binoxide of tin with metallic gold, whilst others look upon it as a compound of binoxide of tin and oxide of gold. Recent researches of Faraday seem to lead to the opinion that purple of cassius is simply binoxide of tin mechanically mixed with metallic gold which has been reduced from solution in an extremely fine state of division. It was formerly largely employed in glass staining, the celebrated old ruby glass being coloured with this compound. Much more is thought of this glass than it deserves, and many persons imagine that the art of producing it has been lost, fabulous sums being occasionally paid for small vessels of it. This is quite a mistake, the art of glass staining was

never in greater perfection than it is at the present day; we can not only make ruby glass equal to the old kind, but we can make it far better, and if the employment of purple of cassius for this purpose is not so general as it was formerly, it is because it is attended with great risk of spoiling the glass, whilst other processes are known by means of which an equally good colour may be obtained with no uncertainty whatever.

PHOTOGRAPHY IN ITS APPLICATION TO MILITARY PURPOSES.

BY JOHN SIPLER, F.C.S.*

Assistant Chemist in the War Department.

(Continued from page 597.)

THE cameras, printing frames, and other similar mechanical contrivances used in our department, are in no way different from those in common use. The necessity for providing means of taking pictures at a distance from the photographic laboratory has been met by the construction of a portable dark room, which, at Shoeburyness, is moved as required by two men, who carry it sedan fashion. There is no flooring, but a loose black canvas border on all sides effectually excludes the light. A working bench, with windows appropriately placed, shelves and wooden partitions for the reception of bottles holding chemical solutions, and on the roof a very effective ventilating contrivance, completes the equipment. At Woolwich we have a photographic van, which was constructed and originally used by the Royal Carriage Department. It is four-wheeled, and, being somewhat large in dimensions, is drawn by two horses, which latter are supplied, when required, from the Military Train Service. Some few years ago, this van accompanied the troops from Woolwich to Dartford, and enabled Mr. Butter to produce a series of photographs illustrative of camp life.

Besides these transportable operating rooms, we have successfully used the square tent designed by Mr. Smartt. On several occasions the Artillery Officers have had "field days," both in the grounds of the Royal Military Repository, and on Woolwich Common, and with tents pitched have, under photographic canvas, allowed me to assume the command. Many useful sketches have thus been secured, and out-door experience gained, which has since been further extended by my pupils, some of whom, at distant stations, have given proof of the value which attaches to photography as a ready means of recording faithfully the geographical and military features of a country, or of reporting details of construction, whether relating to stockades, forts, or suggested improvements in military equipment.

It will be perceived that our usual course of operating has been to sensitize, expose and develop the plate on the spot, so that the resulting picture may be examined and approved before returning home, or removing the camera with the rest of the apparatus to another subject. Much progress has been made towards the perfection of the so-called dry processes since the early date at which, in conjunction with Mr. Crookes, I had the honour of announcing the first and necessarily imperfect results obtained upon this system.

Since the proposals referring to the use of the nitrates of zinc and magnesia, in May, 1854, and the employment of honey, recommended shortly afterwards by Mr. Shadbolt, an immense variety of preservative agents have been successively brought under the criticism of the practical photographer, and the results in many instances have testified to the general efficiency and uniformity of such processes; but it is nevertheless true that at the present moment, we are without a guide as to the precise interval of exposure required for the perfect rendering of detail in the diversified range of subjects to which the camera has to be directed. Then, from the inverted position of the image upon the ground glass, we are, at the time of focussing, apt to pass over little inaccuracies which could not escape our observation when examining the finished negative. Under these circumstances we still prefer for general use the wet collodion process, which has, moreover, the advantage of reducing to a minimum the period of exposure, a matter often of vital importance, as we have already seen.

For collodion, we have of late been dependent upon com-

* Read before the Photographic Society, on the evening of Tuesday, December 1st.

mercial supplies; there are now so many manufacturers who offer uniformly an excellent article, that no difficulty has been experienced in procuring collodion of first-rate quality. We have adopted, likewise, the common practice of mixing two samples for ordinary use. I have lately had an opportunity of seeing very good results follow the employment of carbonate of soda as a means of restoring iodized collodion which has become reddened by age. A few drops of the aqueous solution were sufficient for the treatment of a large bulk of the red collodion; and, after allowing time for the subsidence of the insoluble particles, such a collodion appeared to furnish a denser image and to be more sensitive than before. This mode of proceeding is being carried out by Sergeant Inglis, and, so far as I am aware, is novel.

The process of iron development (using a 15-grain solution of the protosulphate), has given us some of our best results; the plates have then been intensified with pyrogallic acid and silver, applied, usually before fixing, but in some instances, especially when the least tendency to fogging was exhibited, afterwards.

The importance of a good supply of pure water for photographic use has been most conclusively demonstrated in the taking of negatives at Shoeburyness. The wells from which the ordinary supply is taken, are close to the shore, and so near the mouth of the Thames that the water contains more saline constituents than usual, with a proportionately large amount of the chlorides of sodium and magnesium. It has consequently been found desirable to wash the finished negatives with distilled water before drying the film, and applying the varnish. Some of the early negatives, taken at a time whilst this precaution was not known to be necessary, have suffered by the cracking of the varnish, and the appearance of moisture under the film. The deliquescent character of the salts left on the evaporation of the water offered at once the full explanation, and no difficulty of this kind has since been experienced.

Whilst upon the subject of negatives, I feel it a duty to bear testimony to the excellence of a plan of intensifying those which have already been varnished, for which we are indebted to Mr. G. Wharton Simpson. The method consists in first softening the film and varnish with alcohol, and then treating with tincture of iodine, the action being carried so far only as to produce an olive layer of superior non-actinic properties.

The printing process adopted in our Department involves the use of albumenized paper for all purposes. Many trials have been made of the new German enamelled papers, and also of the gum benzoin or resinized paper, prepared according to the instructions of Mr. Cooper. The examination of the resulting prints led me to the conclusion that the brilliant lustre of the enamel papers permitted only of their being employed for small pictures, whilst the benzoin paper, on the other hand, although well adapted for large subjects, did not give sufficient details in the shadows to render its general introduction desirable.

The sheets of albumenized paper are usually sensitized by floating upon a 70-grain solution of nitrate of silver, printed and washed, toned by the alkaline gold process, and fixed in plain hyposulphite solution.

The formula for the gold toning bath has usually been—

Chloride of gold	5 grains
Bicarbonato of soda	20 grains
Water	1 pint.

The acetate of soda process has likewise been occasionally employed. The final washing process has always been considered a matter of grave import, and has been carried out with that scrupulous attention which the necessities of the case demand. After a few preliminary rinsings, the prints are washed in a current of water, for which purpose they are transferred to deep gutta-percha or porcelain dishes, having a lip at one corner, which provides for the overflow without permitting the sheets of paper to escape from the washing trough. An india-rubber joint and glass tube delivers a supply of fresh water without splashing, and the produce of the day's work remains in the water during the succeeding night. On the following morning the prints are dried by suspension from the American spring clips. They are then mounted with glue, and passed through Bury's rolling press. Gum-water preserved with camphor has been to a limited extent employed for mounting.

Faded photographs are almost unknown to us; none have yet been reported, and the few prints I have had occasion to

condemn were instances of after contamination, due either to incautious handling or splashes of the hyposulphite solution. I have to regret my inability to remove, by chemical means, the whole of the silver from the protected white parts of albumenized prints, a difficulty to which I invited attention some fourteen months ago. All my efforts in this direction have hitherto been unavailing, and it has not been found possible to remove this small proportion of silver without using powerful agents, which injure the tone or impoverish the character of the photograph.

Our photographic department is at the present time almost in a transition stage, a new building having been erected for us in the Royal Arsenal, one wing of which will be devoted to photography, the remainder being occupied by the chemical laboratories. The new glass room has its chief aspect nearly north, and is partially lighted both on the west and east. The roof is lofty, and the principal dimensions are 25 feet by 15 feet. Adjoining this are two other rooms which will be devoted to printing and general operating, the former being fitted with moveable sashes, glazed with Claudet and Houghton's red "non-actinic glass." The washing-table occupies one side of the printing room; it is lead lined, and provides a water supply to each batch of pictures.

The negative rack is of the ordinary description, with curtains in front to exclude the dust. We have already a thousand negatives in stock, many of them being plates of the largest size, and from these we have issued during the present year to the various Government Departments upwards of eight thousand prints. The majority of these are sent out mounted on quarto cards, tinted of a pale buff, and with a manuscript description appended.

GLASS ROOMS. AND LIGHTING THE SITTER.

BY W. B. PARKER.*

WHEN asked by your secretary to write a paper for this evening, I hardly knew what to write on that would be at all interesting. There has been so much said upon everything photographic, that one is at a loss to find a subject upon which any new ideas may be brought forth. However, upon looking at the *British Journal of Photography* for the 1st instant, and seeing therein a description of a "glass room," it struck me that such would form a good subject for a paper.

Every one has his pet idea of a glass room, but great is the diversity of opinion thereon; one holding out for plenty of top light, another for plenty of side light, while another says "neither of you are right unless you have an abundance of front light." Still, generally, we find it advised that you should have as much glass as you can get.

For my own part I believe that it does not depend on the amount of light, so much as on proper management. I have worked in many glass rooms, and have seen some of the finest things produced taken where the majority of operators would have been unable to get anything passable; and I have seen some of the worst "pictures" I ever saw, taken in some of the finest rooms.

In the discussion which I desire to originate this evening, I hope we may do something towards tracing out a cause for this difference of results; and we shall find, I think, that it generally arises from a want of knowing how to arrange the light so as to ensure the most pleasing, truthful, and artistic results. It would be impossible to give any set rules for controlling or directing the light, because every different sitter necessitates a different arrangement of the light; but still we may, perhaps, suggest some principles upon which to work with some degree of certainty.

It is necessary that the sitter should receive equal illumination, the feet and accessories being well lit. In some rooms, to secure this is very difficult, through not having a sufficiency of side or front light. This I have overcome best by covering the larger portion of the roof over head with tissue paper (of course it has lengthened the exposure). This gives an extraordinary good effect by weakening the light on the top part of the figure, thus allowing you to bring up the whole of the details in the lower part, and securing a more harmonious picture.

Still it is particularly necessary, to avoid flatness and monotony,

* Read at a meeting of the South London Photographic Society, December 10th, 1863.

that there should be one principal light, so arranged as to impinge upon the principal parts of the face. This principal light should not be too strong, or it will destroy softness; and, although you may get excessive boldness, you will not get flesh. In such a room as I have indicated above, this would be comparatively easy, as the head, being nearest the illuminating source, would receive the most brilliant light, and the other parts would fall properly in their place, especially if the room is a long one, or you have a little front light to soften the shadows. This front light I consider very necessary in all rooms. It matters not whether it is literally a front or a side front, but I should prefer the former. Of course it must not be a strong light, but be properly subordinated—in fact, it should answer the purpose of reflected lights, softening and giving details to the shadows (and by that means helping to give roundness and contour to the features); for, if we are to represent Nature as she ought to be represented, we must get details, even in the deepest shades, and this is one of the best means of getting it that I know of in the way of lighting.

I should advise a certain amount of side light if you can get it. It is not absolutely necessary—still it is useful; and we have the power of stopping out light if we have too much. This side light must not overpower the principal light.

I also find a little subdued light between the sitter and background relieves the figure wonderfully, counteracting that inlaid effect we often see in otherwise good pictures.

In respect to the particular arrangement of light, as I have before said, no fixed principles can be given, as each model requires an entirely different one; for what would suit a person with large full eyes would not answer for one with those useful organs deeply sunk into the head. In fact, in the proper judicious lighting of a figure the likeness to a great extent is secured.

With reference to the direction in which the light should enter, as a general rule I find that an angle varying from forty-five to sixty is mostly required.

The prevailing character of the light should be what is called soft or diffused, but at the same time it should be brilliant or forcible, so that it may enter into and have its influence in the shadows to secure detail even in their greatest depths, detail being a necessary element of roundness.

Returning again to the consideration of front light. It has often been said that a front light is addicted to giving flat pictures—for what reason I do not know, unless it be from a general want of knowledge in operators. I think you will admit with me that the pictures of Disderi, Williams,* and your respected treasurer, Mr. Noel Fitch, are anything but flat, and that in all these cases the principal light appears to be a front one. The same remark also applies to pictures by Rejlander, which are so exquisitely round and well relieved, and whose models receive a direct front light falling from above the head, as well as a subdued side front light. I think, then, the "evils," so called of this particular mode of lighting are altogether a mistake.

Since writing the above, I perceive from an article in the PHOTOGRAPHIC NEWS that Mr. T. R. Williams has re-arranged his light so as to secure a little of what may be termed a high side light. Still, that gentleman's principal light is a front

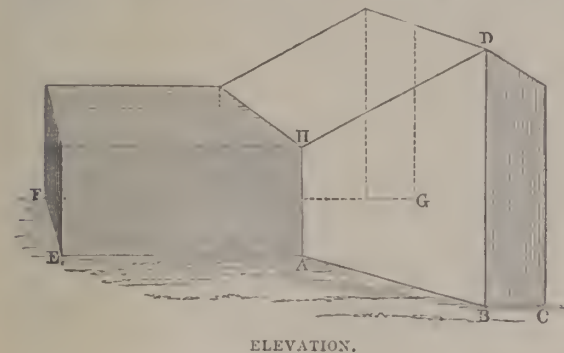

light, entering at a long angle. Perhaps, however, I have said

* It is an error to suppose that in M. Disderi's, Mr. Williams', or Mr. Rejlander's studio the principal light is a front light.—Ed.

enough to show the importance of front light as an artistic desideratum, and one which cannot be discarded with impunity.

In conclusion, I will try to describe how we may build a studio in which all the necessities I have now briefly described may be provided for, and in which we may be able to arrange our light, as the circumstances of the moment may dictate, with the greatest amount of ease and efficiency.

The diagram to which I now call attention shows, you will perceive, a glass room similar to that of Mr. Rejlander's, but with these differences—that there should be two front side windows instead of one, so that we could light from either side as might be most convenient or desirable, and not be constrained to putting the same one side of the face always either in light or shadow. Again, too, instead of being about 5 feet wide, I think they should be not less than 10 feet wide, and fitted with two sets of white blinds and one dark blind, running on rods from contrary ends, so as to secure any amount of light at almost any angle. We thus secure great control over the lighting.

A short time since Messrs. Helsby and Co. recommended, in the *British Journal*, a room, for which they claimed great simplicity and ease in working. Instead of moving blinds, the sitter was to be shifted here or there. I need not point out to my practical brethren the difficulty of getting a nicely-lighted portrait in such a room. Picture the indignation of your sitter upon being shifted now to the right, now to the left, now backward, now forward! and conceive how improving to the expression this would probably be! Surely, the simple moving to and fro of a few blinds would be simpler and easier, as well as more effective.

In conclusion, I may add that, in opening this subject, I hope I may be the means of getting it well aired in a genuine South-London discussion, characterised by its usual animation, earnestness, and good nature. I do not remember that the subject has received any fair share of attention at a society before, and I think it high time that it should now do so, and with this view at once entrust it to the many able gentlemen around me.

GLASS ROOMS.

BY A. H. WALL.*

ALTHOUGH most subjects have received their share of attention at photographic meetings, there is one which appears to have been unaccountably neglected. This one is "Glass Rooms." We started in photographic portraiture with the idea that, as we needed all the light available, the rooms in which photographs were taken could not contain too much glass; consequently, up to the present time, most of our studios have been constructed as if they were intended for greenhouses, the resemblance being not only in the amount of glazed surface secured, but also in the general form commonly adopted.

Mr. Sutton was, I think, the first to point out this blunder by giving a diagram of a room which was a glass room in name only. It contained a long dark passage for the lens and camera, a front top light and side light, and most of my hearers have doubtless seen diagrams thereof. I had long held similar ideas with regard to the proper form of such a room, and finding that Mr. Sutton had done little more than describe the room in question, I set myself to work, and gave my reasons for the belief that was within me in a couple of "Bits of Chat" in *The British Journal*. Somewhere about the same time Mr. Rejlander—in whom, I believe, the same thoughts had been long lying dormant—carried out his ideas, which resulted in a glass room of the principles advocated by myself. Mr. Lamb, of Aberdeen, also wrote to me shortly after the publication of the remarks I had made on the subject; and, on my sending him a rough sketch of a glass room with comparatively little glass in it, he wrote by return, saying that it was just such a room as he had already erected, the only difference being in the fact that he had a glass room at either end of the dark passage in which the lens stood, so as to secure the choice of two aspects according to the necessities of the weather, or the requirements of sitters. Afterwards I gave similar designs to several correspondents who had read the articles I had written on the subject, and were desirous of carrying out the ideas therein developed.

From some of these I have since received communications,

* Read at a Meeting of the South London Photographic Society, December 10, 1863.

which tend to show that the old-fashioned conservatory-like room is a decided mistake, and that for the purpose of photographic portraiture a little *good* light is very superior to a large quantity of it. Mr. Rejlander's experience goes in the same direction, I am informed; and Mr. Lamb's pictures fully bear out the value of that principle, being clear, round, and brilliant, with well-marked but delicate transparent shadows, and an amount of relief not often seen in ordinary photographs.

But I would not recommend the amateur to conclude that, because such and such pictures were produced in a room of this or that description, therefore they have only to secure a similar room to get a similar result. This would be in every sense a great error; for, even supposing an equality of skill, the why and wherefore may yet be as closely associated with many other things as with the peculiar arrangement and amount of light. Mr. Rejlander's room answers admirably well where it now is, but brought into, say the city of London, it might not be at all a desirable building for photographic purposes. I do not say positively it would not, but it might not. The spot selected for the glass house has, remember, its own peculiar features, and these should be duly considered before we decide upon the kind of building it may be desirable to erect. Before deciding, moreover, the photographer should make himself familiar with the different aspects assumed with regard to the light during the changeful day and varying seasons. For instance, it is well known that many rooms may answer admirably during the summer and be useless in the winter—may be worked in with pleasure during one part of the day, and defeat your best efforts during the remainder.

Instead, therefore, of speaking of this or that as the most desirable form of glass room, I shall just briefly refer to a few very simple facts as guides to principles upon which the beginner may form his own ideas as to the best kind of studio for this or that particular locality.

If you want soft pictures which shall not lack brilliancy and force, and desire at the same time to get such pictures with very rapid exposures, you can question yourself, say thus:—"The more pure and powerful the light the better for my purpose. The light which reaches me direct from the sky is purest, and also the most powerful. How can I get this? These trees shut it out there; that house intercepts it here. When the sun is so high, I shall get it; and when so low, I shall miss it. When the sun is there, the best light will come from such a portion of the sky; when there, from such another portion," &c., &c. By this means you may reach a final conclusion which shall decide where your glass room should stand, what aspect it should have, where you had best put your glass, and how large a surface of it will best enable you to catch the best light at different hours of the day and months of the year.

Well, having chosen your plan for a glass room of the kind required, you turn to other considerations. The nearer the light to the sitter the more power will it have, and, consequently, the shorter the exposure will be; but then the balance of power between the lighted and the shadowed sides of the face will be unequal, and, think you, "the lighted side will be isolated before the shadows are out, and I shall get flat, hard, inartistic, that is to say, unnatural effects. How is this to be avoided?" Clearly by letting in a certain small quantity of light to the shadows, and thus diminishing the contrast of power (the relative strength of the light used for the end desired being tested in the only way it can be tested, viz., by experiment). For this purpose I think nothing is better than a certain amount of front light falling more or less downward.

Desiring brilliancy, and knowing that such a quality is not altogether dependent upon chemical conditions, we next think a little on this subject. If, when the sun is out, you let it stream in through a small aperture, and fall between your camera and an object in the room, and then take a picture of such object, you will find that, while the portion of the object seen through the rays of strong light is tame and weak, the other portions are forcible and clearly defined. This shows us how the lesser light on the object is lost in the greater light intersecting its path from the image into the camera; and we have here a hint of no small value, telling us that the more dominant the light on the image over the light filling the space it traverses in reaching our sensitized plate, the better our resulting image. Then how can this be best attained? I should say by excluding all light which does not pierce fall upon the model; and if you ask how this is best done, I should answer by keeping all the light used *in front of the sitter*. If the light enter at the side of the sitter, the angle at which its more direct rays travel, changing

as the sun shifts its position, will fall, now *upon* the sitter, now *between* the sitter, and now *towards* the lens. If the light enter at the top, it is subject to the same changes; but if both top and side light be also front lights, we defy the shifting rays, and secure the light upon the model an uninterrupted reign of superiority.

I had written thus far because I had reason to fear that, in consequence of illness, Mr. Parker's paper would be found wanting, and I was anxious to preserve the reputation of our committee for never letting the members return home disappointed. Mr. Parker's paper, however (as a letter just received informs me), being ready, I need not carry my task further, and shall submit the above to consideration as part of my portion of the discussion which that gentleman's communication will doubtless create.

MOUNTING PHOTOGRAPHS.

M. H. KIMBALL'S PLAN.

Trimming the Print.—For this purpose there is needed a glass plate of the desired form and size of the print, a good penknife, and a thick sheet of plate glass, six inches or more square. The sides should be exactly vertical. This form need not be of plate glass, and it is even better that it should be slightly curved, so that when laid on the print, concave side down, the end edges will first fasten the paper, and by gentle pressure on the middle the whole surface of the glass will be in contact with the paper. The blade of the knife should be thin and of high temper. The operation of trimming consists in laying the print down, impression up, on the plate glass, upon this the glass form, and then cutting away the paper protruding from the form. The cut should be made with a free hand, each cut taking away the whole of the paper from one side. With care this apparatus may last years. If from carelessness, however, the edges of the glass become nicked, it is useless, and a new one must be procured. These glasses may be obtained from the photographic dealers. The print thus trimmed is ready for toning. (We take it for granted that intelligent operators understand that prints should be trimmed before toning, in order to save the silver from the paper clippings.) Prints are also trimmed, and more expeditiously by means of a steel cutting die; of this plan more in future. The trimmed prints toned and dried are ready for

Kimball's Improvements in Mounting.—Procure a block of wood a trifle smaller than the desired size of print, and about three-quarters of an inch thick; through the centre of this block drive a long nail, so that the head shall be flush with the surface. Next cement with sealing wax upon the top of the block a glass plate of a size a trifle larger than the block. The top of the table on which the block is used is pierced with gimlet holes at convenient places, into which the nail of the block fits, thus keeping it snug in its place. For use, the block is set in one of these holes; a piece of cotton muslin of two thicknesses is dipped into a tumbler of water, gently squeezed, and laid on top of the glass. Upon the wet cloth the print is laid, impression down, and the paste (Mr. Kimball uses gum arabic) is laid on with a broad, flat brush. The cloth needs to be constantly damp, but a wetting for about each two dozen prints is found to be sufficient. If the prints are not thoroughly dried after toning, the cloth need not be dampened so often. After pasting, the prints are attached to the cards in the usual way. The effect of the damp cloth is to make the paper flatten out under the paste, and to prevent the cockling of the card on drying. By having the glass plate only the size of the print, the paste is not wasted, and makes no mess, and there is little danger of its getting on the surface of the print.

Mr. Kimball has often had cards mounted at the rate of twenty dozen per hour.—*American Journal of Photography.*

Proceedings of Societies.

SOUTH LONDON PHOTOGRAPHIC SOCIETY.

THE usual monthly meeting was held on the evening of Thursday, December 10th; Mr. Sebastian Davis in the chair.

The minutes of a previous meeting were read and confirmed, and the following gentlemen were elected members of the Society:—Messrs. Aldis, W. B. Parker, Collis, Walmsley, Everett, and F. Yorke.

Mr. Ross sent for exhibition two very fine portraits, by Messrs. Southwell Brothers, of the size they have termed "imperial." The portraits were those of Miss Kato Terry, and Mr. Fechter, as *Hamlet*. The background and accessories illustrated the value of a skilful combination of real objects with scenic effects. The lens was one of Mr. Ross's portrait combinations of six inches diameter, 24 inches back solar focus, and was used with a three-inch aperture, the exposure being about one minute in a good light. Mr. Ross also sent some interiors of the Crystal Palace taken with his No. 2 triplet of 9 inches equivalent focus; the stop used was the 4-tenths of an inch in diameter.

Mr. H. COOPER, jun., exhibited some very charming card and other pictures, chiefly artistic studies, with fine effects of double printing. The cards were described as produced by Dallmeyer's stereo lens, and the larger pictures with the No. 1 triple of the same maker.

Mr. WHARTON SIMPSON exhibited two card pictures by Mr. Pouncey, produced by his printing-ink process. The Chairman called especial attention to the successful results obtained in the face of all the difficulties involved, and the pictures were generally admired.

Mr. ALDIS exhibited some enlarged pictures produced with the solar camera and the oxyhydrogen light, which excited much attention.

After a vote of thanks to the gentlemen exhibiting specimens, Mr. WALL read a brief contribution from Mr. Walter Woodbury, well known for his fine photographs of Java, whose description of photography in that island will be remembered by our readers. He described a process of printing a picture from two negatives as follows:

Suppose it is required to introduce portions of two negatives into one picture, two sheets of talc are produced the size of the negatives, and on each are painted in Indian ink the part required from each negative. These are used similarly to the paper screens generally employed to shield the paper in double printing, but possess the following advantages. They can be cleaned and used over and over again, and can be placed exactly over the corresponding part in the paper, thereby giving no white line, and do not contract or expand as the paper shield often does.

Where it is required to cover some delicate part, such as a lock of hair, lace, or anything that it would be impossible to cut out evenly on paper, there is no difficulty in painting out such part on the talc.

Another method of using it is this:—Suppose you have a portrait to which you wish to introduce a background from another negative. You first block out all the background of the negative, and having prepared the sheet of talc as a dry plate, you take on it a print from the blackened negative, which by over-exposing gives you a shield the exact counterpart of the blackened negative.

Owing to the thinness of the talc no diminution in sharpness takes place.

Regarding Mr. Warner's suggestion for a camera for India, from my long experience there I should think it would not answer, as the slightest moisture inside the camera would keep the lens in a continual steam.

Nothing answers like a piece of black velvet thoroughly damped and laid over the camera, as the rapid evaporation keeps the plate cool and moist for a considerable time. With the thermometer over 95° I have often kept a plate wet for ten minutes.

Mr. WALL then read a paper by Mr. Parker on "Glass Rooms and Lighting" (see p. 606).

The CHAIRMAN, in inviting discussion, expressed his admiration of the glass-room and management of light of Mr. Williams, in Regent Street. He thought the square shape and large size, 30 feet each way, was of great advantage in permitting the sitter to be placed in any desired position, thus meeting the important question of the aspect of the light. He

had his own little glass room, and had tried placing it in all directions. In reference to the question of aspect, the part of the day in which it was most likely to be used was an important consideration. For instance, with a south aspect it would be almost impossible to work between the hours of eleven and one. For professional photographers requiring to work during the whole day, a northern aspect was undoubtedly best, and the light reaching the sitter at an angle of from 45° to 60°. He recommended persons interested in this question to experiment with a white bust, by which the actual effect of lighting would be most easily seen. With a direct front light only it would be seen to be quite flat, but with a light reaching it at a suitable angle the whole would be seen in perfect relief. Perhaps before proceeding to the discussion, it might be convenient if Mr. Wall read his remarks on the same subject.

Mr. WALL then read a paper on "Glass Rooms" (see p. 607). Referring to a direct south light, he said Mr. Rejlander could work with the sun direct on his model, but in that case it was received through the blinds, which were pulled down.

Mr. SIMPSON, referring to Mr. Parker's remark that the subject of glass houses had received so little attention in society meetings, observed that probably no reason why the subject before the meeting was so little discussed was that it was so difficult to treat in the abstract. He was much struck with the truth of this opinion by the paper of Mr. Parker, read that evening, in which that gentleman, referring to the recent alterations in the glass house of Mr. Williams, said that they produced a principal front light, while Mr. Williams's object had been to avoid this, and obtain a high side light, or what painters call "a side front." In reference to the sun's direct rays, which could scarcely be avoided with a southern aspect, he might remind the members that Mr. McLachlan had patented an arrangement of blinds with the express purpose of working with a southern aspect. From the description published it was not very easy to understand the exact nature of the contrivance proposed. He, however, recently had an opportunity of talking over the subject with Mr. Mayall, who had seen the arrangement in operation in Manchester. This gentleman had been so much pleased with them that he ordered them to be adapted to his new glass room in course of erection at Brighton. To use Mr. Mayall's expression, the light was so arranged as to act as an "artificial cloud," and in whatever position the sitter was placed, an intense reflected light might be thrown on him. A southern light, when it could be used, was of course very valuable from its power.

Mr. WALL had tried Mr. McLachlan's plan, and was much dissatisfied with it. All portions of the blind gave off reflected light at different angles, and the image on the ground glass was deficient in clearness and had a woolly appearance. He had hoped to obtain cast shadows by direct light; but the arrangement so altered the light that he got no shadows. He believed, however, that Mr. McLachlan's room was loftier than his, and in a better locality, and these points would have to be borne in mind.

Mr. SIMPSON asked if Mr. Wall really used Mr. McLachlan's arrangement of blinds? or, whether he had only carried out his instructions as well as he could from the descriptions?

Mr. WALL had not had his blinds from Mr. McLachlan, but had endeavoured to carry out the idea himself.

Mr. SIMPSON said that was doubtless the source of the error. Probably Mr. Wall had as much misconceived the real arrangement as he (Mr. Simpson) had done. He had objected to Mr. Mayall that the arrangement struck him as calculated to give a series of small lights instead of one volume of light. Mr. Mayall had assured him of his error, and stated that the results were the finest in point of lighting that he had ever seen. He had heard of others making sets of blinds on what they believed to be Mr. McLachlan's plan, and abandoning them; but he conceived that in these instances they had failed in getting the effect of the genuine arrangement.

After some further conversation on the subject—

Mr. SIMPSON said he was unable to explain the precise arrangement. So far as he understood it, there was a series of narrow strips of wood, hung at right angles to the glass roof, which was placed at an angle of 45°. These were connected, and could be adjusted so as to stand at any position. There was one very important point to be remembered in connection with this subject. However perfect the glass house and arrangements for lighting, they would be of little service to persons who had not an intelligent appreciation of the principles upon which the model should be lighted, and a per-

ception of the right effect when they saw the model lighted. In illustration, he might point to the very burning strokes by Mr. Cooper, then on the table, which were admirably placed, and yet these were produced in a small ordinary conservatory. He was demanded in discussing a question of this kind, of the story of a certain celebrated painter, who, being asked by a pupil with what he mixed his colours to secure such beautiful tints as the painter's answer was, "With brains!"

Mr. COOPER described the position of his room, and his mode of using it. His light was chiefly from the south, and the shade could be used as well over the head of the sitter.

After some further conversation, in which Mr. Simpson referred to the charming and perfectly lighted pictures Mr. Beauchamp had recently exhibited in the room.

Mr. BEAUCHAMP described the method he had adopted to make a conservatory for the purpose of a photographic studio. (See THE PHOTOGRAPHIC NEWS, p. 256.) He remarked that if his room were wider and allowed him to place the sitter diagonally, it would be a great improvement. So far as his judgment and experience went, he protested emphatically against the use of a front light as being either an error.

A conversation followed as to the precise meaning of the term front light. Mr. WALKER defined it as any light in advance of the sitter, whether in the shape of a side window or not. Messrs. Simpson and Beauchamp defined a front light as that from a window in front of the sitter; that from a side window a side light, sometimes from its position becoming a side-front light.

Mr. SIMPSON remarked that if the light at the side seemed to be a side light because it was in advance of the sitter, a side light could not be more than a foot in extent—in fact, the breadth of a man's body. Popularly understood, a side light was that from a side window.

Mr. EVANS, referring to the use of tinsel paper, said, if you do with starch, it speed well. He had 500 or 600 square feet of it.

Mr. COLE referred to the use of tracing linen as much superior to tinsel paper, being very transparent and efficient for the purpose. It was to be had seven yards long and one yard wide. He also recommended the use of spring rollers for black wood without the starch. He would have the boards for the roof to pull up instead of down, and those for the sides to roll laterally.

After some further conversation.

Mr. HART exhibited a model of a small glass house. It was constructed on a plan in general principle similar to that of Mr. Beauchamp, Mr. Matthews, and others, the chief modification consisting in the front part of what may be termed the studio, sloping both at sides and top, towards the narrow, unillumined part.

Mr. SIMPSON, referring to the model as excellent in plan, remarked the principle upon which it was designed was now becoming almost universal. He then briefly described the construction of Col. Stuart Wortley's glass room (see p. 256), which cost £110.

Mr. HART said a house constructed after his model, 24 feet long, the studio portion being 18 feet by 12 feet, and the summer back part 14 feet by 4 feet, the height of the studio 5 feet to the eaves, made of glass and iron, would cost £20.

Mr. HART said a glass house was necessary to protect the sitter from wind and weather, but very fine portraits could be taken in the open air. For his own part, he would have as much glass as possible, and make the studio like a landscape conservatory well supplied with drapery for exclusion of unnecessary light. Drapery had many advantages over blinds, in permitting a variety of arrangements.

The CHAIRMAN referred to the lighting of models in the new series of rooms at South Kensington, and recommended photographers to inspect it.

After some further conversation, the CHAIRMAN announced that at the next meeting Mr. Cooper would read papers on "Weak Printing Baths," and on "Formic Acid in the Developer."

The proceedings then terminated.

REFLECTING SCREENS.—A correspondent has sent us a specimen of silvered paper sold by the fancy stations, which he has found very valuable for covering or shading screens and ceilings when it is necessary, a large amount of reflected light.

Correspondence.

CHROMO-PHOTOGRAPHY.

SIR.—In reply to the letter of Lieutenant-Colonel C. Barrett I beg to say that I have not carefully examined the process which the above gentleman has invented, nor will any one who knows the printing process and the colour it yields in its several stages of exposure say I was wrong in thinking it impossible to produce by the new invention tints so beautiful and so true to nature as may be applied by the artist's brush.

With regard to the art of "producing pictures in the natural colours of the objects by the agency of light," the invention not only does not look like a step in advance, but it is no step in advance with it, because light has not more to do with the production of the various tints obtained by the application of chloride of gold to the prints than it has to do with the printing process in general.

The invention is certainly an ingenious application of the variety of tints which various films of exposure to the gold solution yield, and as such it no doubt deserves appreciation, and will be appreciated according to its merits, but when such an invention is brought forward as belonging to an art which it has nothing to do, it is liable to be mentioned in the manner which seems to have roused the indignation of the gallant Lieutenant-Colonel.

I do not feel inclined to answer to the remainder of the letter, only the passage where it says of photographs coloured by hand that they are "nothing but an abortion not worthy the name of a picture or a photograph," reminds me of the lovely coloured portraits I have seen in Mr. T. R. Williams's room, and seems to prove that the gallant Lieutenant-Colonel cannot have seen anything like them, or else he would certainly not stigmatise them like that unless he had put all his taste into his chloride of gold solution.—I remain, dear sir, yours respectfully,
AROTER BESCH.

THE DISCOVERER OF THE PHOTOGRAPHIC USE OF BROMINE.

SIR.—I am certain the photographers over the country will make a handsome response to the appeal in behalf of Mr. Goddard. I don't think all was done that might have been for the Archer Fund, not from unwillingness on the part of photographers to give, but neglected in the hurry of business.

To obviate this occurring in Mr. Goddard's case, I would suggest that a person be appointed in every town to call upon his fellow photographers and show an name, I hope, but would put their hand to their pockets, and give their mite, but who would put off and perhaps bring their neglect to mind their subscriptions. If it is true that many are making splendid fortunes, let them think and act justly to the man to whom they are so much indebted, and let many who are making a good small living but slowly begrudge to give the price of one dozen "cartes." —Yours truly,
JOHN HENDERSON.

Perth, 14th December, 1863.

Photographic Notes and Queries.

NITRATE OF SODA IN THE PRINTING BATH.

SIR.—Will you allow me to inform your correspondent "Another Photographer's Assistant" that the plan seems to be complete of in his sensitizing bath of nitrate of silver and nitrate of soda are easily explained, and easily remedied, thus:—The nitrate of soda was bad, being feebly alkaline, and an excess of soda or carbonate of soda would, of course, destroy the solution; if he adds a little nitric acid the reaction of the bath is, of course, not at first, but it takes a long time before all the free soda in the bath of the solution has taken by the nitric acid, therefore the reaction being at first good, will become alkaline again after a certain time, if not sufficient nitric acid

has been added, just in the same way as may be experienced in neutralizing a nitrate of silver bath with oxide of silver. It is hardly to be wondered at that the paper, being exposed to nitric acid, free soda, free carbonic acid, and being on the solution while such a chemical reaction takes place in the same, will turn all sorts of colours.

The best remedy for the complaint will be to get good nitrate of soda; but if he has not got it, add nitric acid to the bath in small quantities, and let it stand, frequently stirring for a day or two, then test again, and if it has not a slightly acid reaction add a little more acid, and let it stand again, until it is permanently acid.

Hoping this hint may be of use to your correspondent, I remain, dear sir, yours,
AUGUST BUSCH.

SIR,—On reading "Another Photographer's Assistant's" communication, I quite agree that it is unaccountable his prints becoming green. I should recommend that he brings his bath to a boiling temperature, add its bulk of water, then forty grains to the ounce of nitrate of soda (i.e., if he is certain that it contains eighty grains of nitrate of silver), add nitric acid till slightly acid. If this does not get him out of his difficulty, the fault must be in the paper, or "Photographer's Assistant" has got something else in it (his bath). I have always obtained the best results by having double (at least) the quantity of nitrate of soda to that of silver.

By-the-bye, I have lately had a troublesome negative bath (pin-holes in millions). I added its bulk of water, filtered out the iodide, evaporated nearly to crystallization, made it up to more than its original quantity and strength, added water to the collodion, got fresh iron collodion, acetic acid, &c., with no better results, when I hit on the following "perfect cure;"—To each pint of bath I added an ounce of prepared chalk, shook and filtered, then added acid nitric till the bath worked clear. No doubt there was a quantity of foreign matter in the bath, which all previous treatment failed to remove.—I remain, sir, yours respectfully,
PUBBLICO.

P.S.—I may state that I sunned and neutralized the bath with no success.

London, Dec. 14th, 1863.

DEAR SIR,—I think that, as a photographer, "Another Photographer's Assistant" should have known better than to expect to obtain the same results as others if he did not strictly adhere to the formulas given. Now, if he will refer to the first published formula, he will find that "Pubblico," (PHOTOGRAPHIC NEWS, April 24th), insists upon an excess of nitrate of soda being present if we are to obtain the best results, and the Editor's remarks thereon confirm the same. "An Amateur," in the number for July 17th, gives the same formula, and speaks very highly of it. Again, in the number for October 16, we find a formula still with an excess of nitrate of soda, as also in the numbers for October 30th, and December 4th. Your correspondent himself seems to know that it should be so when he mentions the one who gets prints of unsurpassed brilliance on an 80-grain soda and 30 or 40-grain silver bath, and yet, in the face of all this, he makes a bath by adding 30 grains soda to a 40-grain silver bath, and then wonders that he does not get good results. In the next place it would be well if he took the advice of the Glenfield starch manufacturers, and when he asks for nitrate of soda "see that he gets it," for the latter part of his letter reads very much as if he had been supplied with a sample of common soda instead of nitrate of soda; and if such was the case he cannot be surprised that it should dissolve off the albumen. I would advise him to try again, with a fresh example and an excess of the same in his next bath. Enclosed are three prints on Schering's albumenized paper from the same negative. No. 1 floated four minutes on solution, 60 grains nitrate of silver to the ounce, without any other addition whatever. No. 2, floated five minutes on solution, 35 grains nitrate of silver and 80 grains nitrate of soda to the ounce; and No. 3 floated 30 minutes on solution, 5 grains nitrate of silver, and 60 grains nitrate of soda to the ounce. They are all toned and fixed in the same bath. Please say what you think of them as the productions of a
GREENHORN.

December 15th, 1863.

[Those with the weak solution of silver are certainly equal to that with a 60-grain nitrate solution.—Ed.]

ELECTRIC LIGHT.

SIR,—I am sorry to say my progress with Ruhmkorff induction coils, about which I wrote some time ago, has been but a poor one up to now, for the following reasons:—

Firstly, my time has been too much taken up by my business, so that I could not possibly devote to the subject the attention I could have wished to give it.

Then, of the two makers of coils whom I know, the one did not seem inclined to push the matter, and the other will have all his hands occupied for two or three months to come, by a large order for Australia, so that he could not undertake any fresh orders, nor had he any stock on hand. A good friend of mine in Birmingham, who is a very skilful photographer, wished to make some experiments, and saw the latter maker several times, but, at the time that I thought he was experimenting, he wrote to say he could not get a proper coil to do it with. I applied to two London firms, not makers, but was asked such prices for the apparatus, that I did not think of recommending them. Up to now, I have not been able to find out any London maker; I dare say there are several, but I do not know them. Thus I have been compelled, to my great regret, to disappoint those correspondents who take an interest in the matter.

Mr. T. R. Williams told me some time ago, that he has made a series of experiments with the Ruhmkorff coil at the Polytechnic long since; of this I was not aware when I wrote my letter, or else I should of course not have thought of recommending attempting to use the light for portraiture. Still, for printing purposes, it may do nevertheless.

Should I find out a respectable London maker of coils and batteries, I shall not delay communicating it to those correspondents who have applied for it, for I still think those coils, and the powerful light they give, may be advantageously applied for printing purposes.—Believe me, dear sir, your obedient servant,
AUGUST BUSCH.

Talk in the Studio.

A "LIFT" IN A PHOTOGRAPHIC GALLERY.—An action was tried a few days ago, in the Court of Common Pleas, to recover the price of a "lift," intended to raise sitters from the basement to the top of the house without the trouble of walking upstairs. The plaintiff, Mr. Gerish, an engineer and ironfounder, carrying on business at East Road, Hoxton, sued the defendant, Mr. Bernstingl, a photographic artist, in Regent Street, to recover the sum of £55 for making a lift and fixing the same on the defendant's premises. The defendant's photographic rooms being at the top of the house as usual, for the purpose of obtaining the light, it occurred to the defendant that it would be an accommodation to his customers if the fatigue of climbing up the stairs could be avoided, and he put himself in negotiation with the plaintiff, who has been accustomed to make lifts, or small ascending rooms, wound up by chains and machinery from below to any required height, for houses in the city. The plaintiff, in February last, agreed to make a lift for the defendant for £50, and the extra £5 was for cutting away brickwork, &c., in order to fit the same. The lift was made and fitted, and tried, and found to work, six persons being elevated thereby to the photographic room. The defence to the action was that the lift was so defectively made as to be useless, and incapable of being worked easily, and that the plaintiff had been required to take it away, and that it was now at the defendant's premises only a nuisance. The evidence on the part of the defendant was to the effect that though a person might be raised up to the defendant's room, yet it was by a series of jerks. The jury ultimately found a verdict for the plaintiff for £55, the learned Judge reserving leave for the defendant to move to reduce the amount of the verdict upon a point of law made by Mr. Joyce.

ARTIFICIAL LIGHT FOR ENLARGEMENT.—Mr. Aldis, of Baker Street, has recently shown us some excellent enlargements produced by an adaptation of the oxyhydrogen light to the solar camera. The exposures range from half a minute to 10 minutes, depending upon the amount of enlargement. Development printing is of course used, but an exceedingly good tone, free from the unpleasant green tint sometimes seen, is obtained. The capability of successfully using artificial light for enlargements, instead of waiting for direct sunlight, cannot well be over-estimated in a country where sunshine can never be guaranteed.

THE GODDARD RELIEF FUND.—Photographers are earnestly requested to respond early to the appeal made in our last, in favour of Mr. Goddard, the discoverer of the photographic use of bromine. Subscriptions already received will be acknowledged next week.

ROYAL PORTRAITS.—We have received from Messrs. Southwell Brothers, some very pleasing portraits of various members of the Royal Family, recently taken at their studio. They consist of the Prince and Princess of Wales, the Queen of Denmark, the Princess Dagmar, and the King of Greece, in various single portraits and groups, some of which are very fine indeed, notwithstanding the unfavourable weather in which they were taken. We believe that the lens used was Ross's No. 3 card lens.

TRACING LINEN FOR BLINDS.—Mr. Cole has courteously forwarded us some examples of the tracing linen to which he referred at the South London meeting as being valuable in shutting out direct rays of the sun, without excessive diminution of light. One sample is labelled "very old," but is still perfectly white. Another article called "tracing cloth," is more opaque, and turns yellow with age. The tracing linen is thin and delicate, and more transparent than tracing paper. It is to be had of various widths, 18, 28, 36, and 41 inches wide.

PHOTOGRAPHY IN CAPE TOWN.—Mr. Arthur Green, a correspondent in Cape Town, sends us some very interesting card-portraits and remarks:—"The best collodion that I can find is one I make myself; it is bromo-iodized, consisting of iodide of cadmium and ammonium, and bromide of cadmium, the latter in the proportion of one and a half to two of the combined iodides; developer, double salt of iron and ammonia, 30 grains; formic acid, 10 minims; water, 1 ounce; alcohol, *quantum sufficit*. Intensity with the formula you give, of 5 grains iron, 10 grains citric acid, water 1 ounce; and, if necessary, after fixation, with ordinary pyro and silver solution. Russell's original tannin solution is found by the majority of operators here to be preferable to the tannin and honey, as being more certain; and although my experience has not been very great, still I can endorse this general opinion.

PHOTOGRAPHS AT SOUTH KENSINGTON.—It is stated that the sale of photographs of Raffaele's Cartoons and other works, formerly conducted by the Science and Art Department, has been handed over to the usual trade publishers. Messrs. Chapman and Hall are the chief agents. The effect of this step has been very nearly to double the price. The Department in future will only issue to the Schools of Art in connexion with it.

To Correspondents.

**** PRESENTATION PRINT.**—With the PHOTOGRAPHIC NEWS of January 1st, 1864, we shall present each of our subscribers with a beautiful specimen of Mr. Duncan Dallas's process of photo-electric engraving. This process has been universally acknowledged to be the most perfect method of photographic engraving yet discovered, possessing perfect half-tone and gradation with great force and vigour. The subject is the "Banqueting Hall, Kenilworth," from a negative by Mr. Francis Bedford, the size of the print just permitting it to be used as a page of the PHOTOGRAPHIC NEWS. The print will be from a plate untouched by the graver. It will be printed on toned plate paper, and will be valued as a charming picture, as well as an interesting illustration of a valuable process.

TO AGENTS.—As there is reason to anticipate a large demand of the No. for January 1st, agents are requested by the publisher to send their orders for extra copies as early as possible.

PLATO.—The silver in your hypo bath must be precipitated as a sulphide, by the addition of liver of sulphur. The silver in the washing water must be precipitated as a chloride by the addition of hydrochloric acid, or common salt. The gold in your old toning baths may be precipitated in the form of metallic gold, by the addition of protosulphate of iron. You will find detailed instructions for these processes, and for reducing the metal, in our YEAR-BOOK, which will be ready in a few days. 2. So far as we can see, the irregular tint in the sky of your stereo print is simply due to a similar irregularity in the negative. 3. Formic acid is valuable in dull weather. The proportion can only be decided by experiment, as various samples differ so much in strength.

GEORGE STANHAM.—So far as we can see, there will be no difficulty in obtaining a good position for a glass house at the top of your house. See papers and discussion at the South London Photographic Society, reported in the

present number; also, article on the subject in our forthcoming ALMANAC. 2. A strong iron developer is the best for winter. 3. Transparencies for the magic lantern may be taken by the wet process, but they require toning. See article on the subject, by Mr. Blanchard, in our ALMANAC. JOHN KEYNOLDS.—We believe Marion and Co. make albums for 10 by 8 pictures. Possibly also Solomon or Bourquin.

JONAH.—You may take landscapes with a card lens, if you use a small stop. 2. All the collodions you name are very good; perhaps a is the most sensitive. 3. We are not familiar with the stocks of second dealers; but we don't think it probable, as a rule, that you would save much by purchasing second-hand dishes and pressure frames.

R. G.—We do not know of any one at present, but will remember. **J. S. W.**—We strongly suspect that you have used carbonate of soda instead of nitrate, which would precipitate all your silver as you describe. See letters on this subject in the present number.

EXPOSURE OF TANNIN PLATES.—A. A. sends us two prints from tannin negatives which received from 20 to 25 minutes exposure on a bright day in September, with Ross single lens, 15 inches focus, $\frac{1}{2}$ -inch stop. His method of working resembles that of W. G. O., described in our last. He states that with a Fothergill plate he would obtain much quicker, although less certain, results. We cannot help thinking that by a modification of his method of working the tannin process, more rapid results might be obtained. See article in the present number by Mr. Hurst.

G. LEWIS.—The negative is very much under-exposed. Try a collodion containing double the proportion of bromide, or add at least a grain of bromide of cadmium or ammonium to each ounce of the collodion you did use. Let your tannin solution not exceed 10 grains to the ounce, and give a longer exposure. There are some interiors in which it appears quite impossible to get a good negative with a dry plate; with a wet plate, it might be desirable to cover up the plain glass window opposite the camera with dark cloth for the portion of the time of exposure.

AMATEUR.—The roof would be better in the form of the dotted lines, but the shorter half should be opaque. See articles in the present number. Eight feet will limit you somewhat in width; six feet more each way would be an advantage.

CHEMICUS has sent us a very pretty specimen of double toning. It consists of the portrait of a little child, the bright golden hair of which is kept very warm in tone, whilst the dress is of a warm or purple black.

A LADY AMATEUR sends us an account of an old camera, much resembling that described by Mr. Kirkby, as Matthew Boulton's. The date, 1843, was, of course, some years after the discovery of photography, but it is interesting to find a lady practising the art in a remote Scottish town like Moffat, so early as 1843.

JAVA sends us a piece of the varnished yellow paper used in diaphanic, which he finds the best material for the dark room window, being easily fastened to the glass, or stretched on a wooden frame. It is of a deep, rich yellow tint, somewhat resembling the colour known as Etruscan yellow. We will report next week as to its non-actinic character.

NEGATIVE.—It is difficult to form, from description, any certain idea of the value of such a room as you describe. A trial would be more valuable than an opinion, and the former you can easily make. Block up the window in the south end and place the background there. Then make a few trials with such light as you have, and send us examples of the results produced. We can then advise you as to the modification necessary. Your letter, which is dated Nov. 15th, only reached our hands this week.

G. M. RENAWAY.—Thank you for the copy of rules, which may be valuable in furtherance of the project.

F. W. EVANS.—Received, and will be acknowledged in due course. The other subject shall receive full attention in due course.

R. M. A Subscriber *ab initio*.—Your letter has been forwarded to "A Photographer's Assistant," and you will doubtless receive a reply in due course. Some delay may arise from the letters being sent to him altogether and not singly, as received.

A. B.—You will be able to get Turner's negative paper of some of the dealers, but we are uncertain of who may have it in stock. We cannot tell you the wholesale price of transparencies.

NIL DESPERA VIDI.—The prints have been fixed, or rather imperfectly fixed, in old hypo; some traces of hyposulphite of silver have remained in the print, and subsequently become decomposed. Damp would facilitate such decomposition.

ARTHUR GREEN.—The cards are very interesting, and the lighting very good. Several Correspondents in our next.

ERRATUM.—In the letter on "Reduction of Residues by London Refiners," in the NEWS for December 4th an error occurs. The cost of 380 ounces of nitrate of silver at 3s. 5d. should have been stated as £64 18s. 4d., instead of £64 18s. 4d., showing that the offer of 380 ounces of nitrate of silver in return for 350 ounces of chloride of silver was a very liberal one.

Photographs Registered during the Past Week.

- JAMES TOMSON, ESQ.** Barut Green House, Bromsgrove,
Photograph of Barut Green House.
Photograph of James Tomson and Family.
- MESSRS. W. AND D. DOWNEY, 9, Eldon Square, Newcastle-on-Tyne,**
Three Photographs of Sig. Gavnra.
One Photograph of J. Cookson, Esq.
- MR. HENRY J. WHITLOCK, 11, New Street, Birmingham,**
Portrait of Sims Reeves.
- MR. ABRAHAM WIVELL, 16, Islington, Birmingham,**
Photograph (from Engraving) of Shakspeare's Bust at Stratford-on-Avon.
Photograph (from Engraving) of Shakspeare's Monument at Stratford-on-Avon.
- MR. GEORGE EMPRINGHAM, Union Workhouse, Glanford Brigg, Lincolnshire,**
Photograph of Sir Robert Sheffield, Bart.
- MR. JOHN AYLMER, 6, Hamilton Row, Dublin,**
Photograph of the Rev. C. P. Fox.
- MR. THOMAS HAYWARD CHAFFIN, Yeovil, Somerset,**
Two Photographs of "Tom King."
- MR. WM. HENRY HIGGS, Fore Street, Bodmin, Cornwall,**
Two Photographs of Mr. R. Porter (imbecile) of Flushing, Cornwall.

THE PHOTOGRAPHIC NEWS.

Vol. VII. No. 277, December 24, 1863.

CONTENTS.

	PAGE
Photographs in Printing Ink	613
On the comparative Value of the Daguerreotype, Collodiotype and Calotype Photographic results (as regards Portraiture) in point of Beauty, Permanence, &c. By James Ewing ...	613
The Birth of an Art. By Godfrey Turner	615
Light	616
Correspondence—The alleged Early Photographs—Electric Light	

	PAGE
for Portraiture—The Tannin Process: Is it slow or rapid? —Southwell v. Ordish	617
Photographic Notes and Queries—Glass Rooms	618
Talk in the Studio	618
To Correspondents.....	618
Photographs Registered during the past Week.....	618

PHOTOGRAPHS IN PRINTING INK.

Mr. Poncey continues to progress in perfecting his last carbon process. He has recently given a practical form to a most important improvement. In our first notice of the results, we stated that the chief drawback consisted in a somewhat unsatisfactory colour, and in the necessity for using a thin transparent paper, which materially detracted the artistic effect of the finished picture. In both these respects considerable improvement has been made.

In our earliest experiments with the prepared paper, we found that much of the dingy olive tint which seemed to pervade the blacks and half-tones could be avoided, if the transparent print were mounted on a paper possessing a very delicately pale tint of pink. This seemed to change the whole tone of the picture, without suggesting the presence of colour in the lights. We suggested this improvement to Mr. Poncey; but, at the same time, expressed a conviction that a method of transferring the print from the thin transparent paper, necessary for its production, on to a more suitable ground, would be the most desirable improvement. In the recent specimens we have received, he has combined both these improvements, and the pictures, card portraits, are barely distinguishable from silver prints.

In order to render the transfer easy, a slight modification in the preparation of the paper has been necessary, and experimentalists wishing to obtain such a result should, in ordering paper, expressly state that it is required for the transferring process. The printing operations are the same as those already described in our pages. The completed print is then attached, the inked side downwards, to the mount of delicate pink, with some adhesive material not readily softened again by moisture. The best substance is still a question for experiment. When firmly attached and dry, the surface is sponged gently, the thin transparent paper at once becomes detached, and may be lifted away, leaving on the mount a perfect impression in printing ink, with every gradation of half-tone possessed by the negative.

At present there is some difficulty in procuring the suitable mounts, and it is necessary, to secure the best tint, to use paper for the transfer, mounting this subsequently upon cards in the usual manner. The steady perseverance and skill with which Mr. Poncey devotes himself to overcoming obstacles, and improving his process are worthy of all praise, and we hope his efforts will be eventually crowned with the success they deserve.

ON THE COMPARATIVE VALUE OF THE DAGUERREOTYPE, COLLODIOTYPE, AND CALOTYPE PHOTOGRAPHIC RESULTS (AS REGARDS PORTRAITURE) IN POINT OF BEAUTY, PERMANENCE, &c.

BY JAMES EWING.*

In looking over the exciting history of photography—from the last great act of instantaneity (viz., the making of a

picture in the 1-36th part of a second) to the time when the greatest minds of the period were delighted with the phenomenon of the darkening of lunar caustic or horn silver; or, further back still, to the accidental moment, fraught with one of the greatest wonders of the future,—that quiet oen in which Porta, the artist, discovered the inverted picture of the outside scene on his darkened studio wall,—that which led to the construction of the *camera obscura*, and first awakened the desire to obtain on its whitened sheet the images which the light reflected—we find the engrossing desire steadily maintained through the whole of the archives was “how to attain the image of man.”

Wedgwood and Davy were delighted with the results they obtained on simple nitrated and chlorided papers, and glowed with enthusiasm when showing their friends, by the dull light of a taper, negative pictures of opaque or semi-transparent subjects. That was in the year 1803; and already had the desire begun to assume a practical form, for we find at that date, exactly sixty years ago, a paper published in the “Journal of the Transactions of the Royal Institution,” by Wedgwood, with observations by Davy, entitled “An Account of a Method of Copying Paintings upon Glass, and of Making Profiles by the Agency of Light upon Nitrate of Silver.” Here already was an attempt to cut out the black profiles of the day, without the assistance of the camera, by reversing the colour of the profile, having it white on a field of black.

The camera was adapted to give subjects from nature, but the chlorided paper was found too insensitve to make pictures by reflection; yet the great Davy succeeded in making images by means of the solar microscope. Thus, long before the time of Mr. Talbot, chlorided paper was used in the same manner as it is used in the solar camera of the present day.

Niépce followed up by placing his resinized surfaces in the camera, and obtaining faint images of architectural and natural subjects; but as yet man had not graced the photographic tablet through the medium of the camera. About this period, however, the magician Iodine was raised from the laboratory of nature to work the spells of photography. The artist Daguerre summoned this geni of the camera to his aid; and soon after, to the astonished world, he made the invisible to become apparent, and produced the wonderful sun-picture!

Yet the optical apparatus was far from admitting of a portrayal of the lord of creation; and it was in 1840 that a gentleman in New York, by using a lens of larger aperture and shorter focus, succeeded in obtaining the first portrait in Daguerreotype. Lucky fellow he must have been, to be the first whom the loving sunbeam condescended to enshrine in mirrored memory! Thus, at length, the charm was broken. That man was the first to mark a new epoch in portraiture, more beautiful and more truthful, but, alas! less permanent, than its canvas ancestor.

It would thus appear that the art was considered incomplete till it properly represented “the human face divine”—that last and finishing work of an Almighty Artist. Portraiture, then, is one of the great branches of the art; and

* Read at a Meeting of the Glasgow Photographic Association, Nov. 11th, 1863.

any process which the art involves, that gives the most beautiful and permanent results, must be considered the most valuable as regards the portrayal of humanity.

In point of beauty, then, it appears to me that no process gives such fine results as that of the Daguerreotype, seeing that it fulfils all the requirements desired by those who have in any measure studied the aesthetics of this particular branch of photography. By it, the most life-like pictures have been made; in fact, one of our local artists used to advertise "speaking likenesses." Without endowing them with the faculty of speech, and, at the same time giving the artist his due, they were very telling portraits. Many of his, and of many other artists who were then practising the art here, come before me yet to be copied or cleaned; and I can assure you they come like "sunny memories," reminding me of a time when really pretty pictures were made by a process much revered, but now superseded. There was a roundness and depth given to the subjects which I have never seen equalled by the other processes—a sharpness, minutæ of detail, clearness of line, and, with all this, a gradation of light and shade softly delicate. They seemed to reflect the beautiful image of one's friend in a mirror. You might fancy you could touch the reality, so quietly did the background recede from the figure. Now-a-days the background comes up to the utter exclusion of the figure, which seems to have some connection with a furniture warehouse in the distance; or that it dwells in "marble halls," being a mere statue in the centre. Moreover, there was a warmth and brilliancy about the Daguerreotypes which all the toning baths of the present fail to excel. Pretty pictures, which have had their meed of praise awarded them in being likened to the Daguerreotype, have been produced by the collodiotype; but the calotype pictures will in no manner bear comparison, so different are they in make and appearance—the one being the direct heir of the camera, the other the effect of light thrown from its parent's shadow. In them there is a want of that softness possessed by all the other requisites which the silver plate had, and which I fear can never be rendered in sombre black and white without being placed on a reflecting medium.

The second great quality in a photograph is permanence; nor can we wonder that such is desired in those light-formed images so beautifully true. All that we can wish for next to the original is there:—each line correct, each feature given; the grey hair, with its peculiar curl; the thoughtful eye, with its quiet look; even the individuality impersonated in the pose; and where such pictures are aided by binocular effects, how wonderfully true! Before such the poet and painter must bow, and the sculptor resign his chisel. The curious, cunning work of the sunbeam cannot be rivalled when joined with optics in such illusion that cheats the sense of sight itself, and from flat planes raiseth before us in palpable form the beings we love. It is a sad thing to think that those pictures which thrill us with their truth and fidelity, and which seem to spring from the invisible, should, after a short sojourn in the land of figures, again return to invisibility. We can fancy the first photographer's emotions as he stood entranced scanning the images that used to scamper across his camera glass now captive held at last, and immediately after perplexed with the thought of how to stay their visit—at that time a very transient one, as the hyposulphite of soda had not yet been applied. His feelings, somewhat modified, may still apply to our own, as our further discussion of this subject will show.

The calotype—or more properly speaking paper photograph—has many advantages in its favour, that of reproduction being one of its most important features, as also its portability and adaptability to a variety of uses. It permits of being used without case or frame, and if it fall, it is not easily broken. Certainly, these are great recommendations; but, unfortunately, it sadly lacks permanence. Toning baths have been devised for the colouring and the rendering more permanent of the image obtained on the chlorided surface.

These have the power of extracting a portion of the reduced chloride, and of substituting gold instead; thus the original image, built up by the light, is partially removed and something else added. I have often wondered whether this doing and undoing does not affect the stability of the image, as I have for a long time past had by me prints taken from the printing-frame, which, after having been washed, and passed through the hyposulphite of soda bath, look as bright as on the day they were dried. Of course their colour is not so charming as those that had passed through the gold-toning bath, being red: but they have the excellence of being more permanent, as placed before their darkened brethren of the same date. They retain their red and white, whilst the blacks of the others turn to a leaden colour, and the whites to that delightful colour which allows us to work in darkness and concerning which there is so much darkness. Of course your old antagonist, the hyposulphite of soda bath, is blamed: your prints have not been properly washed. But why do the red prints retain their whites, whilst those that have had the deep violet tinge added to them, assume such a faded appearance? This is a question I should like answered, or at least have you to think over, as you know the old hyposulphite of soda bath has long been in disrepute the *sel d'or* reckoned only a little better, whilst the alkaline gold-toning bath has had a fair trial, and still the voice of truth proclaims our work unstable. The Exhibition test was a tough one; and I see a motion is being agitated by a certain society for the purpose of storing up the effigies of the notables of the present, only the members do not know well how to proceed, as this stumbling-block of impermanence stands in the way, and cannot be readily got over. In the plain paper prints there was a tendency towards the image sinking in the pores of the paper, which in a great measure was obviated by the instituting of albumenized paper; but this albumenizing has brought on a host of difficulties which have to be contended with, the greatest of which seems to be in the fact that a portion of the silver employed in the formation of the picture cannot be extracted by means of the hyposulphite of soda bath, and consequently must tend to the impermanence of the print.

It is unfortunate that so much can be said against this division of our comparison, as it is the most generally useful and workmaking branch of the whole profession.

We shall now turn to the collodiotype positive, the formidable rival of the Daguerreotype. It could be looked at in any light—give the image non-reversed, if required, but seldom done—could be coloured, and, more, varnished; but its great recommendation was that it could be made the medium from which any number of copies could be thrown. It will be observed of the glass that it did away with the old paper negative "botheration." Like the Daguerreotype, however, these pictures had to be kept in case or frame. By this process many beautiful portraits were made; but until they were varnished their permanence was much less than that of the unglilded silver plates, such instability arising in many cases from the different developers used. As, for instance, a picture the silver of which, from rapid development, was thrown down in large flakes, spongy and white, would not endure in the common atmosphere so long as the development of which was prolonged, the minute particles of silver precipitating in a more metallic form, and when finished assuming more of the colour of a good Daguerreotype—a clean, frosted silver appearance, with the high lights and deepest shadows given without that hard dash of black and white too characteristic of this process; but the necessary black varnish was difficult to obtain that should possess the good quality of not cracking or becoming powdery, as is the case with most varnishes after the volatile oil with which they are impregnated vanishes, the resinous substances left breaking up into thousands of ridges. Such was the case with the black enamels used in backing of collodiotypes. Cloth and paper were often substituted with less effect. This unfortunate cracking was over the cause of pictures being brought back to the photographer as spoiled

and faded, and yet the customer would remark that they "had not been kept in a damp room." The transparent varnish in front of the pictures, which promised great permanence in the subject, and which caused many operators to advertise "everlasting photographs," also gave way; and, in the case of soft precipitates, the oil in the varnish permeated the soft film, giving an unpleasant tone to the picture, and eventually running into streaks. This process, however, has given more permanent results than its offspring, the paper, and many beautiful collodiotypes are scattered over the land. Of course the process of making the negative of the present is nearly one and the same, the black varnish being omitted; yet the same difficulty is felt in regard to the transparent varnishes used, as they often crack the film containing the picture, which, if you attempt revarnishing, ten chances to one you do not carry away the whole substance forming the negative. Yet the collodiotype has conferred a great boon in even producing for a short time positive results on paper which, if we could only retain them in a permanent form would indeed be valuable.

We now come to the startling process which first awoke the world to the practicability of retaining images given by the camera, viz., the Daguerreotype—the only real dry process that has given satisfactory results which cope with and, in my opinion, far supersede any process yet known, wet or dry. True, instantaneous pictures could not be had by it. True that, if rubbed or exposed to the air, certain damaging effects must ensue. Yet, as true is it of the Daguerreotype that no other process has given such satisfactory results, applied to portraiture, in point of beauty, permanence, &c. This may seem a sweeping assertion, but I shall, after a lengthened acquaintance with the processes named, endeavour to prove its admissibility; in fact, it appears to me that the very nature of the process will bear out my argument, being so far different from that of the calotype and collodiotype, the images by which are the result of silver in a weakly reduced state, held in a mechanical manner on the surface and in the pores of two substances that have no chemical affinity for the metal, and only hold the molecules of it as a sponge does water, so loosely put together that the slightest disturbing influence alters its condition. In those processes, too, it is difficult to get rid of the chemicals which acted in the formation of the image, and which, if the slightest trace be allowed to remain, is sure to produce decay—decay which twelve hours' washing under a running tap, with all the recent forms of tubs and dripping apparatus, have failed to cure, and I doubt ever will. In the Daguerreotype the case is materially altered. You have the pure silver surface—the metal, in fact, to work upon. You use the chemicals required in their purest form:—the iodine evaporating from its crystal; the element, bromine, also in a state of vapour. These rise to the surface of the pure metal; they sensitize the plate, which, after exposure in the camera, is brought back and developed with the vapour from the pure element, mercury. Again, after passing through the decolorizing hyposulphite of soda bath, it is coated with the pure element gold. You will observe that all the elements forming the Daguerrian image are pure natural products, uncontaminated with any secondary material, the metals used having a powerful chemical affinity for each other. Mercury, ever desirous of forming an alloy with silver, becomes the medium in its joint condition to mingle with the gold, thus building up a compact image of three noble metals, each and all difficult to oxidise in a pure atmosphere. Still further, the tablet, being of pure silver, admits of no chemical action from the back, and of no decaying element from within. All decay must be in front. The varnish of gold must be first attacked by atmospheric influence. This gilding, being carefully deposited over the whole plate, and not on the metal forming the immediate image, as in the calotype, is difficult to oxidise, and that so slightly that long-continued action from simple natural causes make small difference upon it.

We now come to what we mean to use as a test on these three photographic results, and it is this:—The Daguerreotype,

often from being badly glazed, exposed to a bad atmosphere or damp, becomes coated with brown or blue hazes, which for a time dims its beauties, many thinking that it has faded away; so also does the collodiotype, and there is no doubt about the calotype's fading propensities. Now, in the case of the Daguerreotype a certain strength of cyanide of potassium, carefully administered, restores the image at once to youth and beauty. Try the same on the collodiotype, however little oxidised, and it begins to assume the dissolving principle of Mr. Pepper's ghost, which, after the exhibition, leaves only a glass behind. Test the paper images in the same manner, those fixed in the old hyposulphite of soda bath, the *sel d'or*, or the alkaline gold toning bath—so forcibly spoken of over two years ago—and you will find that all accept the cyanide as their "ticket-of-leave."

In making this comparison I have endeavoured to show up the somewhat neglected merits of an old (and in point of permanence, tried) process, without saying aught of the other processes but that which is true. And my desire in doing so is to stimulate you to greater endeavours in the making of those truthful resemblances which, however large or fine, if they want the quality of permanence, can never be esteemed as they deserve; and if, from what has transpired in the past, we can learn or suggest something better for the future, much good will be accomplished. Such is my apology for these remarks.

THE BIRTH OF AN ART.*

BY GODFREY TURNER.

There was once—not so very long ago but that people now living can remember seeing his works as they were newly exhibited in London, Paris, and other great cities—a man who carried a certain skill of illusion to so marvellous a pitch, that he could in one picture show "the season's difference," the changes of day and night, and besides all kinds of natural phenomena, the progressive effects of devastating fire. His faculty being merely imitative, it was said that he had "no art." That is a question we need not argue in this place. For the present purpose it is enough to say that this man could set before us a natural scene—in all respects natural. The spectator sat in a darkened room, one end of which seemed open to the free air and a wide expanse of country—let us say, an English landscape, though the range of the artist's subject (we may call him "artist" for the nonce) was as various as in each picture were the aspects which half an hour would seem to bring about. There are corn-fields, and a homestead, and green trees, and the tops of village roofs, and an old church tower; and there is a brook in the foreground, with a deep still pool, darkened by overhanging boughs. The water glides, and ripples, and glistens, and lies still, not with mechanical sameness and repeated obtusive trick, but variably, and with the quiet, constant air of nature, half in motion and half in repose. There is a wooden bridge, and its reflection in the stream actually follows every little trembling movement of the surface, and is even true to the influence of every passing cloud. It is early summer time, and clouds are passing, just as if the blue beyond were sky and not painted canvas. They gather, concentrate, and pour down rain. The effect is so thoroughly natural that you listen for the splashing in the water. Every drop is seen distinctly to fall like a plummet on the face of the brook and on the face of the pool; but it falls with strange, unaccustomed noiselessness. The heavy, down-pouring streams now begin to slant, and the tops of the trees to stir and bend. The highest branches are flattened together, and they start and stoop, and stoop more and more, as the wind appears to be gaining strength, and to drive the rain sidelong, ruffling the waters. A flash—a sudden lull in the storm, and a gradual dispersing of the clouds, while another flash and another succeed. A rainbow shows that

* *Everybody's Journal.*

the summer tempest has passed, and now the sun shines out again upon the leaves and the grass, wet and glistening.

More changes follow over the same landscape.

A summer sunset, a mellow harvest-moon, paled by the sudden blaze of distant hayricks.

A bright December day, dying in the gloom of a cold December twilight, the waters freezing as we look; a snow-storm shrouding the dead ground; early spring again, and cheerful sunshine and budding trees.

So with other scenes. The artist, defying—or, perhaps, knowing nothing of academic rules of art—constantly presented to our wondering eyes the most perfect imitations of natural effects. All “cosmoraucic” attempts which have followed those we speak of are mean, bungling, and coarse by comparison. The great mass of spectators admired unquestioning, and freely indulged their common love of wonder. Artists even would snatch a fearful joy, and ease their consciences afterwards by making severe remarks on trickery and realism, and the falseness of combinations. Meanwhile, the man went on “combiuing,” and crowds were still delighted.

But he was not quite satisfied himself with the results of his toil; such truths as he had discovered in the course of his researches in chemistry and optics had given him a new idea. These transitory aspects of nature, these constant changes which give beauty to commonplace, and which, taken away from beauty, leave it cold and grim—was it not possible to arrest them, to collect the rays of their reflected light in a camera, and fix the image on a tablet? He told his wife the awful thought, and she turned pale. It is an authentic fact, that one night, after going with her husband to hear a scientific lecture, she contrived an interview with the lecturer, drew him apart, and with painful agitation implored him to tell her whether the fancy her husband had taken into his brain was the fancy of—a maniac! The professor smiled, and consoled her by saying that her husband's visionary idea might one day be found practicable enough.

This man, then, who dreamt the poet's dream of retaining beautiful shadows; this madman, as his anxious wife, reasoning with the world's reason, deemed him—this no-artist, who so loved nature, was named Daguerre. His dream was the Daguerreotype.

That your philosophy, and especially the practical kind, falls a little short in its calculation of the things that are in heaven and earth, an obscure dramatic poet has ventured to assert. It is a pleasant, certainly not a strange, coincidence, that he who noticed that little failure of philosophy should have attached an almost substantial value to shadows. In one of his plays—“A Midsummer Night's Dream,” it is called—the word occurs an extraordinary number of times, and always accompanies some graceful plea for fancy or imagination. This play has a quaint epilogue, spoken by a fairy, and beginning with the language, “If we shadows have offended.” It is a most charming piece of supplication. The noble and dignified good nature of one of the characters in this said play—a mortal and a duke—puts the same thing in a more human way. Another of the *dramatis personæ*—a lady—is very hard on a certain “tedious brief comedy,” setting forth the loves and sorrows of Pyramus and Thisbe, with their sad ending; and this kind-hearted potentate meets her ridicule with a reply which ought to be written over the proscenium of every theatre. “The best in this kind,” says he, “are but shadows, and the worst are no worse if imagination amend them.” The finest part of the matter is that this Duke Theseus is an eminently practical man in his way; that is, he is a man of decisive action; and he has no transcendental notions that we hear of. He belongs to the governing class; he hunts, enjoys himself, gets married, all in a splendid fashion, and with an absence of untoward circumstance which is quite prosaic, when the troubles and vicissitudes of the other characters in the play are taken into consideration.

The author of that play himself—one William Shaks-

peare—was not a bad instance of the fusion of ideality and business. Amid a great deal that is not at all certain in his biography, there is at least one thing that is. He made a will. Further, it is quite plain that he really had something to leave out of earnings which, considering the nature of his work, we may regard as the tangible results of imagination—the substance pertaining to the shadow.

It may be worth while to recollect such things whenever we pass that most common of street objects, a photographer's case of specimens. From a shilling portrait on glass, “including frame,” to the most perfect and artistically beautiful miniature by Dickinson or Lock, the present writer may truly say that he can never look at a photograph without its calling to his mind the material uses of imagination, and the birth of a new art in the brain of Daguerre.

LIGHT.

In analyzing a ray of light, if the spectrum be divided into 360 parts, the red will occupy 45 parts; orange, 27; yellow, 48; green, 60; blue, 60; indigo, 40; violet, 80.

Light travels at the rate of 192,500 miles in a second of time, according to Herschel.

In the prismatic spectrum, violet rays indicate heat as 1, green as 4, yellow as 8, and red as 16. Beyond the red no peculiar action exists.

The colours of bodies depend upon the size of their atoms, and the chemical character of the local atmospheres of their atoms and interstices. Black has small atoms, and absorbs light; white large and reflects it. Reds are of oxygen character, according to Ellis; greens, nitrogen; and violet, hydrogen. Their minute parts decompose incident lights, absorb some, and reflect others; an oxygen body combining with hydrogen, and reflecting red; and the contrary with others; thus a hydrogen atmosphere absorbs red, &c., and reflects blue and indigo, &c; and a nitrogen absorbs red and violet, and reflects green or white, orange or blue.

The complementary colours are—for black, white; white, black; red, blue green; orange, blue; yellow, indigo; green, violet red; blue, orange red; indigo, orange yellow; violet, bluish green.

When the shadows of the same object projected on a wall by two lights are equally dark, the lights themselves are equally intense; but if not, the darkest shadows will be protected by the interruption of the brightest of the lights; and if this brightest light be then removed further from the wall, till both shadows become equally dark, and the distances of the lights from the wall be measured in that situation, the intensity of each will be in proportion to the square of its distance. For example, if two lights give shadows equally black or dark, when their distances from the wall are respectively five and seven feet, the intensity or quantity of light omitted from them will be respectively as 25 (or 5×5) and 49 (or 7×7).

Bodies which refract most reflect most, or are more splendid. The local atmosphere which increases one increases the other.

Reflection is in intensity as difference of refractive power in the media.

The full moon produces no heat.

The optic nerve enters the eye .11 of an inch from the axis of the eye, on the nasal side; the axis is .91.

Angle of vision taken in by the fixed eye, 110 degrees.

Impressions on the eye are permanently continuous which are repeated 7 times in a second. When the sea is a blue colour, it is deep water; and when green, shallow. The film of a soap bubble about to burst is only about three-fourths of the millionth of an inch in thickness.—*Scientific American.*

FADED PRINTS.—The action of bi-chloride of mercury in restoring faded prints will be discussed at the next meeting of the North London Society. Mr. Godbold will read a paper on the subject.

Correspondence.

THE ALLEGED EARLY PHOTOGRAPHS.

SIR,—Respecting Mr. James Watt's progress in photography, I find an extract in the *Mechanics' Magazine*, August 30th, 1823. First article, 1st No. and 1st vol., which may be interesting to your readers.

In a "Memoir of James Watt," the writer quotes the words of "One who knew him well," and continues:—"After the year 1817, he applied himself, with all the ardour of early life, to the invention of a machine for copying sculpture and statuary, and exhibited his performance amongst his friends, as the production of a young artist just entering on his 83rd year."

It may be interesting to find who this authority is. The magazine gives no further trace.

I take this opportunity of expressing my thanks for the information I have received from your very liberal and valuable journal.

Since taking it, I have been quite an enthusiast in photography.—I am, Sir, yours very respectfully,

JOSEPH PODMORE.

Oxford, Dec. 21, 1863.

ELECTRIC LIGHT FOR PORTRAITURE.

DEAR SIR,—Mr. Busch has somewhat misunderstood me in supposing that I had, in my experiments with artificial light for photographic portraiture, used a Ruhmkorff's coil; indeed, at that time it had not been invented. In a somewhat extended series of experiments, undertaken at a time when the Daguerreotype process was the only method used for photographic portraits, I tried many forms of artificial light, amongst which were the electric light, the Bengal light, the Drummond light, and others, but in no case with perfectly satisfactory results. The electric light was most actinic, but was too intense and concentrated, and produced the usual result of an intensely brilliant direct light; it gave chalky lights and heavy black shadows, and by rendering it impossible for the sitter to sit with open eyes, was destructive of expression. With the less intense lights the difficulties were lessened, but the exposure was more prolonged, rendering them unsuitable for portraiture.

Amongst the various experiments tried was the natural one of using screens for diffusing and reflecting the light, which effected some improvement; but the final issue of my experiments at that time was decidedly unfavourable to the employment of any artificial light for photographic portraiture.—Yours, dear sir, very truly,

T. R. WILLIAMS.

236, Regent Street, Dec. 21, 1863.

THE TANNIN PROCESS: IS IT SLOW OR RAPID?

DEAR SIR,—Mr. T. Hurst, by his able and intelligent comparison of the tannin process, as practised by "G. W. O." and myself, has anticipated the remarks I intended making on this interesting subject.

I will here add a few more details of my method of working, as it is only by careful comparisons of facts that it is possible to arrive at more correct conclusions respecting the capabilities of this beautiful and simple process. I am unable to supply any information as to the amount of bromide contained in the sample of collodion I employed; I believe it to be considerable; in fact, the bromide ought to be in as large a proportion as possible, consistent with easy and quick manipulation, plain bromized collodion being rather too slow in getting thoroughly decomposed in the nitrate bath, to quite please me. My bath was the usual 35-grain one, containing 15 drops of nitric acid (sp. gr. 1.360), in 40 ounces of solution; at the time of using it, it had had about 60 half-plates sensitized in it.

As you will easily perceive, this was very acid, but as I

found a neutral bath gave me rather foggy plates, I preferred keeping on the safe side, especially as I did not find any appreciable loss of sensitiveness occasioned by this degree of acidity.

It is my impression that the plates are more sensitive when the tannin solution has remained on the film for some little time; some plates prepared in my usual way, but simply coated four times with fresh tannin, were very slow, and gave fog and stains in the lower part; those on which the tannin solution remained for 2 minutes, were clean, but certainly not so quick as those coated for five minutes or more. When my time permits, I intend trying the effects of an iron developer, of course taking care to wash off all the tannin, before developing, with plenty of water or dilute alcohol. Perhaps also the process could be reversed, so to speak, a plate being coated with collodion containing nitrate of silver, dipping it in a solution of iodide and bromide, washing and coating with tannin. This might be found to have some advantage in the greater rapidity of preparation, as the adhering weak solution of iodide and bromide could be more easily washed off than the nitrate of silver. They would perhaps be very susceptible to the actinic influence; the plates would thus be "sensitized" by the tannin which it is said, "renders them as sensitive as by nitrate of silver."

For the present, however, I am well content with the tannin process, *pure et simple*. In conclusion, I am glad to say that my experience enables me to endorse fully Mr. Hurst's remarks and summing up.—Believe me to be, dear sir, yours very truly and obliged,

H. C. JENNINGS, junr.

London, Dec. 22.

SOUTHWELL v. ORDISH.

SIR,—In your Journal of yesterday's date, you refer to the above case, recently heard before Alderman Carter, and remark "that the decision given is, not unnaturally, very unsatisfactory to the plaintiffs," &c., &c.

It struck me on reading a report of the case in the *Daily Telegraph*, that no evidence was offered before the magistrate showing that the Messrs. Southwell had reserved to themselves the copyright of the photographs in question by agreement in writing signed at or before the time of such sale or disposition by the vendor, &c., &c., in accordance with the provisions of the 25th and 26th of Victoria, cap. 68, sec. 1. It was stated that Messrs. Southwell claimed the copyrights of the portraits of Miss Thompson and another because they took them from the living originals.

I need not remark to you that this, *per se*, will not meet the requirements of the Copyright Act.

If A. B. is paid for taking the photograph of C. D. in the absence of the written agreement referred to in the Copyright Act, no right of property in such photograph can be legally claimed by A. B.—Yours obediently,

AN AMATEUR.

December 19th, 1864.

[The first section of the Act is somewhat obscurely worded; but, if we understand it rightly, no agreement or signature is required where the artist takes the picture for himself. It is then his, and if he registers it, no one may copy it without his permission. If, as our correspondent remarks, A. B. were paid for taking the portrait of C. D., then, in the absence of an agreement, no copyright would be obtained by either party. But, in the case in question, C. D. does not pay A. B., but sits for A. B. at his request, and for his purpose: in some cases C. D. is really paid by A. B. for the sittings. In such case we have no doubt the copyright is legally vested in the author of the work, and no agreement is required until he sell a negative. See the Act, first section, "Provided that when any painting or drawing, or the negative of any photograph shall be for the first time after the passing of this Act sold or disposed of," &c.—Ed.]

Photographic Notes and Queries.

GLASS ROOMS.

DEAR SIR.—In reference to W. B. Parker's paper on "Glass Rooms and Lighting the Sitter," we beg you to inform your numerous readers, that we are not in the habit of dancing our sitters about the room to get them properly lighted.

We would advise W. B. Parker, in future, not to make dogmatic assertions of people, before he knows something of their antecedents, and of the facts of the case.—Yours truly,

HELSEY AND CO.

34, Church Street, Liverpool, December 22, 1863.

Talk in the Studio.

PHOTOGRAPHY IN PARIS.—The rage for photography, and especially for "cartes de visite," is now furious in all quarters of Paris; indeed, in many streets, the houses are about equally divided between shops where they sell "comestibles" or diverse drinks, and those where you can have your "counterfeit presentment" taken for sums varying from one franc to one hundred. A few days ago a *porteur d'eau* presented himself at the studio of one of the most eminent photographic artists, and said, "Monsieur has taken the portraits of the Marquis and Marquis X., and their daughter?" "Perfectly," replied the artist. "Will then, Monsieur, be so polite as to give me copies of them, as they alone are wanting to complete my album of customers." I have said it is a rage, and so it is; no age or personal appearance can stop the fever of photography. The wife of my concierge, who is not in her *première jeunesse*, and who even, when she was, could have scarcely been a beauty, is to-day having five francs' worth—frame included—to give her husband on the *jour de l'an*. Even those who wish to avoid the operation cannot, as they are enticed into a studio, and "negatived" before they can say "no!" It is not a pleasant operation either, this being photographed; indeed it produces a disagreeable recollection of youthful visits to the dentist. An intensely hot room—dark, except where a blinding ray of light, destined to be turned full on to your eyes, streams through the window; such is the scene of suffering. Now for the suffering itself—you take a seat on an uneasy chair, an instrument of torture is applied to your occiput, a table is pushed "artistically" into your left side, a strong man moulds you as he would a lump of clay, "your head, there! good—half close your left eye! there, charming. There, there, good, beautiful, your arm. Ah! a spasm; that will pass. There, good, your foot, ah!" and having undergone this mild but irritating torture for twenty minutes you are told to "look pleasant" for ten more while the artist studies your inverted figure. "We must suffer to be beautiful," says the French proverb, but speaking from personal experience I must say I have undergone the conditions without obtaining the result. In spite of this, however, the "Beautiful"—spelled with a big B—is so inherent in some natures that I have actually to-day seen four photographs, not only good but pleasing.—*Paris Correspondent Daily Telegraph.*

REDUCTION OF CHLORIDE OF SILVER.—MM. Millon and Commaille have communicated to the French Academy of Sciences, an extremely elegant reaction, by which absolutely pure metallic silver may be precipitated from its ammoniacal combinations, with all the accuracy necessary for rigid analysis, and in such a division as to render it available in the arts. The reagent employed is ammonio-subchloride of copper. When this substance is added to ammonio-nitrate or ammonio-chloride of silver, the whole of the silver is at once thrown down in the metallic state as a grey amorphous precipitate. The precipitate readily assumes a metallic lustre under the burnisher, and may be applied to the surfaces of wood, stone, &c. The reaction takes place so perfectly, that it may be employed either for the estimation of silver, or for the analysis of a mixture of sub and protosalt of copper; every atom of silver thrown down representing gone atom of subchloride of copper. It is, however, especially valuable for reducing the chloride of silver residues of the laboratory. These are dissolved ammonia, and the ammoniacal subchloride of copper added, when the metallic silver is at once obtained in its purity. Moreover, it is only necessary to digest the filtrate with a little powdered zinc in a closed flask, in order to again reduce the copper salt, and it is ready for a fresh operation. In this way, the same quantity of copper solution suffices for an indefinite number of precipitations.

*^o PRESENTATION PRINT.—With the PHOTOGRAPHIC NEWS of January 1st, 1864, we shall present each of our subscribers with a beautiful specimen of Mr. Duncan Dallas's process of photo-electric engraving. This process has been universally acknowledged to be the most perfect method of photographic engraving yet discovered, possessing perfect half-tone and gradation with great force and vigour. The subject is the "Banqueting Hall, Kenilworth," from a negative by Mr. Francis Bedford, the size of the print just permitting it to be used as a page of the PHOTOGRAPHIC NEWS. The print will be from a plate untouched by the graver. It will be printed on toned plate paper, and will be valued as a charming picture, as well as an interesting illustration of a valuable process.

TO AGENTS.—As there is reason to anticipate a large demand of the No. for January 1st, agents are requested by the publisher to send their orders for extra copies as early as possible.

To Correspondents.

*^o With the present number, containing title-page, preface, and index to the volume, four pages extra are given, without charge.

THE GODDARD RELIEF FUND.—We have received several subscriptions for this fund, but are compelled to allow a detailed acknowledgment to stand over until our next.

C. UPROX.—You may keep a little kaolin in your filter, always allowing the silver solution to pass through it when returning it to the bottle. We do not use kaolin at all, preferring the mode of decolorising the bath by the addition of a few drops of a solution of salt and water. 2. There is no objection in adding fresh acetate of soda to a toning bath in use, but if you have done so accidentally, it will not do any harm.

NITRATE.—If, on adding nitrate of soda to your silver bath, the latter turned turbid, the nitrate of soda had contained some impurity, either a chloride or carbonate, probably the latter. Other nitrates may probably be used, but we have not tried them.

A. YOUNG AMATEUR.—Various samples of collodion are used by different photographers for use with the collodio-albumen process. Probably 1 or 5 on your list will answer your purpose. 2. A tripod should not be shorter than 5 feet 6 inches in height. The question whether it should be folding or rigid is purely one of convenience. Rigidity is desirable, but it interferes somewhat with the portability of the tripod.

A. G. GRANT informs us that he has used nitrate of soda in the printing bath at intervals, during the last 8 months, with success and without difficulty, making the nitrate for his own use. 2. We shall have pleasure in receiving the description of a travelling studio. 3. It not unfrequently happens that the same idea occurs to various inventors, quite independently. Others have also conceived a washing machine very similar to the one in question.

SHEFFIELD.—The imperfections of your prints proceed rather from the negative than from faulty toning. The negative is not quite sufficiently dense in the lights, and is a little fogged in the shadows. With a better negative you will find it possible to get better prints. Steady perseverance and care will overcome your difficulties, do not suffer yourself to be laughed out of your efforts to improve. We are glad you so appreciate our labour, and are obliged by your kind wishes for the season.

W. ABERDEEN.—The cards have been forwarded. The lighting is, we fear, in your positive, difficult to remedy. The toning and printing are pretty good.

M. WYNTER.—So far as we know, the lens, regarding which you make inquiry, is a really good and useful instrument.

F. LOW.—In order to secure the copyright in a photograph, it is necessary to register it before any copies are sold or disposed of. If any copies were put in circulation before you registered, you have lost your remedy. If any one sells copies of pictures in which you have a copyright, you must take proceedings before a magistrate.

P. VINCENT.—The red or brown tone of your developed print is the result of over-exposure and under-development. The cause of the spots is less certain, they may arise from some defect in the paper, they may arise from drying the excited paper before a fire or gas stove, and be caused by contact with sulphur.

LEX TALIONIS.—Your letter on our contemporary's invention of what he terms "oral literature," or, as you phrase it, "spoken writing," and on what he terms "sarcasm," is amusing enough to the few interested in the matter. To the majority of our readers it would be neither instructive nor interesting, and we cannot devote space to matter understood by, and interesting to, half a dozen persons. In answer to your question, we certainly never heard of "oral literature" before, but we don't care to undertake the task of pouncing upon and exposing every blunder we meet with.

AN ENGRAVER.—You may doubtless obtain information from the patent agent. We intend to make some further inquiries, and will publish anything of interest we may learn.

We go to press one day earlier this week, and a large number of correspondents are compelled to stand over until our next.

Photographs Registered during the Past Week.

- Mr. E. DENMORE, 51, Malden Road, Haverstock Hill,
Five Photographs of the Rev. Carter Smith.
Mr. A. S. WATSON, 2, Regent Road, Great Yarmouth,
Two Photographs of the Rev. Amblett.
O. Photograph of the Rev. Symonds.
Mr. JAMES R. BERTSON, 77, Lauchhall Street, Glasgow,
One Photograph of the Rev. Alexander McQuisten.



ARCHES, and some of the uses of photography, by Thomas Sutton, Esq., B.A., 65
Accelerating effects of bromides in collodion, the, by Charles Waldack, 163
Accelerator, formic acid as an, 277, 443
Accomplishment, photography as an, by Rev. S. Miller, 114
Acetate of soda in the toning bath, chloride of lime and, 419, 433
Acid, iron developer without, 311, 323
Aid to toning, 239
Actinic conditions at a high elevation, 442
— spectrum, the, 173
Actinism, moisture and, 383
— on certain states of the atmosphere with respect to, 346, 347
Actino-silver deposit on the collodion film, to thicken the, 332
Action of light, measurement of the chemical, 273
— on bromide of silver, on the, by M. Aug. Testelin, 27
— of nitrate of silver upon albumen, on the, by MM. Davanne and Girard, 53
— of photographic varnishes upon the collodion film, on the, by Dr. D. Van Monckhoven, 233
— of the blue ray, Mr. Brookes on the, 273
— of the sensitizing bath, theory of positive printing, albumenized paper and the, by George Price, 126, 137
Adjutor, 266
Aerial photography, 269, 297
Aeronaut, a photographer and, 491
Aesthetics of photography, by M. Disderi, the, 330, 343, 333
Affinity of water for dissolved glass, 304
Agents, new fixing and developing, by M. Meynier, 111
Albumen, on the action of nitrate of silver upon, by MM. Davanne and Girard, 53
— on the coagulation of, by M. Mc A. Gaudin, 5
— prints, imperfections in, 166
— rendered insoluble by salts of silver, is, 154
— salts of silver and their department with, 207
— substitutes for, for positive printing, by H. Cooper, 186
Albumenized paper, fuming with ammonia, 85
— proportion of salt, 556
— glass process, by Charles Waldack, 415
— paper, alcohol in the sensitizing bath for, the philosophy of its action, 30
— coagulating the surface of, 84, 216
— the patent, 9, 47, 103, 324
— nitrate of soda in, 463
— transferring the image to porcelain, 421
Album photographs, by Wilson, 513
Alcohol, cheap, 24
— from coal gas, preparation of, 183
— impurities in, 309
— in the sensitizing bath for albumenized paper, the philosophy of its action, 30
Alkaline developing agents, 530
— development, unkerel marks on tannin plates, 469
— rapid tannin plates with, by Thomas Sutton, 489
— test paper, 119
— toning solution considered, 568
Alleged early photographs, the, 616
Almanac, the Photographic News; 1863, 16
Alumina salts, 14, 29
Amateur photo. association, 165, 163, 239, 356
— photography in America, 181
— portraiture, 157
— in open air, 119
Amateurs, a tribute to, by Mr. Hughes, 567
America, amateur photography in, 181
— fuming and printing in, 457
American photographic society, 177, 236, 287, 3, 586
Amr da, development, 2, 120
— development by fumes of, by Verity, 133
— fumes in printing, 85, 169
— fuming sensitive paper with, by Geo. S. Penny, 158
— in printing, 181
— nitrate bath, 23
Analogy of the eye to an optical instrument, the, by J. Z. Laurence, 451
Analysis of the fixed line D, 491
— of the silver solutions used in photography, by Frances Sutton, 523
Angle of aperture of a lens, a new method of ascertaining the, 500

Angle of photographs, measuring the, 395
— measure of the, 593
— of view, 408, 321, 372, 401
Animal, effects of light on, life, 275
Anthony, magic lantern slides, by, 322
Aperture of a lens, a new method of ascertaining the angle of, 500
Apology for art-photography, by O. G. Rejlander, an, 83
Apparatus for panoramic photographs, 523
— for viewing photographic pictures, 321
Application of stereo, to detect forgery, 310
Architectural photographs, value of, 420
— stereographs, 403
Arinstein, Alexander, preparation of gutta-percha paper by, 143
Art in photography, by M. Blanquart Evrard, 281, 306, 493
— of taking enlarged photographs, micro-photography, or the, 293, 378
— in connection with photography, by Lieut.-Colonel Stuart Wortley, 496
— photography, 71
— an apology for, by Rejlander, 83
— discussion on, 95
— and its critics, 61, 124
Artificial light for enlargement, 611
Artist in trouble, pinholes and varnish, 464
Artistic copyright, 62
Assaults in photographic studios, 453
Asser's, Mr., process of photolithography, 12
Assizes, photography at the, 374
Athenaeum on photography, the, 359
Atmosphere with respect to actinism, on certain states of the, 346, 347
Auro-eupric toning, by C. Ommeganck, 472
Australian photographs, 557
Australia, photography in, by Paul Riccochet, 412, 425
Authenticated formulae, 221
Automatic washing apparatus, 599
Auto-typography, the new art of, by George Wallis, 199, 212
BACKGROUNDS, vignettes, 156
Bad glass plates, 467, 477
Bad taste, photography and, 174
Balloon photography, 329
Bank notes, how to prevent forgery of, 323
Baths, toning, 351
Battery for the electric light, cheap, 526
Bertrand, M., new process for positive printing, by, 101
Best side of the face for portraiture, the, 144
Bichromates, the varied action of light upon bitumen and, 493
Binocide of hydrogen, ready formation of, 3
Birth of an act, the, by Godfrey Turner, 615
Bisulphide of carbon prisms, 491
Bitumen and bichromates, the varied action of light upon, 493
Blacking the brasswork of lenses, 539
Black tones, toning experiments, 265
Blanchard, Valentine, on the developing and intensification of the photographic image, by, 298
— line toning, experiments by, 316
— on the production and use of cloud negatives by, 424
Blanchard's manipulating box, 458
Blue ray, Mr. Brookes on the action of the, 273
Bolton's camera, Matthew, 576, 587
Book packets and newspapers, 59
Borders, ornamental photographic, 320
Brasswork of lenses, blacking the, 539
Brebisson's, Alphonse de, treatise on instantaneous dry collodion, by M. Ernest Saint Edme, 603
Brewster, Sir David, and the stereoscope, 275
Bringing home the May, 287
British Association, 422, 411
Bromides and iodides in collodion, 116, 131, 217
Bromides in collodion, 10
— the accelerating effects of, by Charles Waldack, 160
Bromide in potassium iodized collodion, 278
— of silver, behaviour of in light, 521, 531, 546
— of silver, on the action of light on, by M. Aug. Testelin, 27
— only, rapid tannin plates with a, 156, 193
— value of a, 523
Bromine, the discoverer of the photographic use of, 593, 610
Bromo-iodized collodion and pyro development, 516
Brookes, Mr., on the action of the blue ray, 273

Browne, the Rev. J. C., M.A., Emmanuel College, Cambridge, a photographic glance at Melrose, 350
Bullock's mounting machine, 108
Bunsen, R. W., for M. R. S. and H. E. Roscoe, B.A., chemical action of direct and diffuse sunlight, by, 473
Burning clippings of prints, 275
By what means can the art of photography become a science, 293
CABANET'S printing process, by M. Lacan, 402
Calcio-chloride of gold, 228
Camera for the Lancashire fund, the, 216
— for travelling, 177
Camphor crystals, 178
— on water, the movement, 376
— towards the light, the motion of, 190, 285
Canvas, photography on, 23, 35
Caoutchouc, the preservative qualities of, 35
Cape Town, photography in, 459, 612
Carbon printing, by A. Landur, 23
— history of, 445
— prints on plain paper, 485
— prisms, bisulphide of, 491
— process, new, Mr. Pouncey's, 360
Card almanac, for 1864, 575
— lenses, Shepherd's, 276
— pictures, novel use of, 334
— portraits, by Mr. Srony, 394
— portraits, enamelled paper for, 195
— portraiture, 553
Case of need, a, 333
Catechu as a preservative, new dry process, by W. S. Craig, 470
Celestial photography, 550
Century, photographs in the last, 337
Chalk in the toning bath, 479
Cheap glass house, 317, 455
Chemical action of light, measurement of the, 273, 439, 473
Chemical dangers, 523
— experiments, by John Kibble, 136
Chemicals, photographic, their manufacture, adulterations, and analysis, 14, 39, 209, 242, 267, 289, 314, 335, 364, 387, 448, 495, 544, 579, 604
Chemistry of painting, the, 508
— short lesson in, 162
Cheshire, rambles about, 122
Children, instantaneous portraiture for, 223
Children's pictures, 595
Choosing glass suited for the operating room a simple method for, 126
Chromate of lead, impressions of, by Dr. T. L. Pliphson, F.C.S., &c., 184
Chromophotography, 597, 610
Clark, Mr., and photo. as a fine art, 259, 272
Clarke, Mr., reply to, by R. A. S., 263
— notes on the collodio-albumen process, by, 247
Claudet, A., on some phenomena produced by the refractive power of the eye, 412
Chloride of calcium box, the, by Charles Waldack, 31
Chloride of silver, behaviour in light, 521, 531, 546
Clean, glass plates, how to, 466
Clippings of prints, burning, 275
— what to do with the, 236
Cloud negatives, on the production and use of, by V. Blanchard, 424
Clouds in landscapes, to secure, 11, 13, 59
Coagulating albumen on albumenized paper, 84, 216
Coagulation of albumen, on the, by M. Mc A. Gaudin, 5
Collodio-albumen process, notes on the, by W. D. Clarke, 247
Collodion, decomposition of, by Dr. Van Monckhovea, 198
— by J. Milton Sanders, 308
— films, 177
— film dissolving when varnished, 313
— formulae, 111
— negative film, a simple method for transferring the, by Dr. Schauss, 333
— photographic, the salts it should contain, and their proportions, by Charles Heisch, F.C.S., 340
— process for positives, by Charles Waldack, preparations employed in the, 307
— study of the wet process, by M. L. Reynaud, 29
— by Dr. F. Fuchs, 320
— very rapid, 564
— the manufacture of photographic, by W. L. Noverre, 434, 450, 459, 471

- Collodion, wet or dry, by M. L'Abbé Despratz, 100, 188, 259
 — for dark rooms, 155
 — photographs, 438, 551
 Coloured photographs or double toning, 598
 Colouring photographic pictures, 232, 431, 438, 551
 Colours, photography in, 515, 526
 Comparative value of the Daguerreotype, collodiotype, and colotype, photographic results (as regards portraiture) in point of beauty, permanence, &c., on the, by James Ewing, 613
 Comparison of photographic substances, expeditious method for the, by M. Mc A. Gaudin, 125
 Composition photographs, on, 112
 — of the photographic picture, on the, by Eugene Sahler, 390, 436
 Concert in aid of a photographer, 203
 Conservatories, a plan to make available for photographic purposes, 255
 Constitution, nature and, of the finished negative, 71
 Continued use of the same toning bath, 106
 Cooper, H. jun., formic acid in the developer, by, 229, 278
 — substitute for albumen for positive printing, 186
 Copperplate printing by photography, 114
 Copying and enlarging, by A. Maenab, 184
 Copyright in works of fine art, 218, 236, 392
 — of photographs, the, 55, 72, 134, 244, 601
 — reproduction and, 386
 Cornwall Polytechnic Society, Royal, 396, 478, 492
 Correcting disordered baths, 589
 Correspondence, 610
 Correspondents, 12, 24, 36, 48, 60, 72, 84, 96, 108, 120, 132, 144, 156, 168, 180, 192, 203, 216, 228, 240, 252, 264, 276, 288, 300, 312, 324, 336, 348, 360, 372, 384, 396, 408, 420, 432, 444, 456, 468, 480, 492, 504, 516, 528, 540, 552, 564, 576, 588, 600, 612, 618
 Costly lens, a, 507
 Cotton, M.A., Rev Arthur, memorandum of a photographic trip in Norway, by, 53
 Court court, photography in the, 569
 Court, photography in the police, 6
 Cracked varnish, remedy for, by H. B. Nichols, 81
 Craig, W. S. new dry process, catechu as a preservative, by, 470
 Critical notices, 16, 99, 122, 182, 219, 232, 266, 303, 323, 365, 518
 Critics, art photography and its, 61, 134
 Crookes, F.R.S., William, photography and engraving, by, 483
 Crystalline deposit on negatives, 119
 Cumulative effects in photography, 395
 "Cured" photographs, 599
 Custom house, sensitive plates and the, 412
 Daguerreotype process modified, 539
 Dallas Duncan, Photo-electric engraving and observations upon sundry processes on photographic engraving, by, 439
 Dallmeyer J. H., the triple achromatic lens, by, 511
 Dark box, improved, 599
 Dark rooms, coloured glass for, 155
 — glass for, 395
 Davaine and Girard M.M., on the action of nitrate of silver upon albumen, 53
 — researches on positive printing, by M.M., 545, 569
 Davaine and Girard, general study of photographic positives, by M.M., 210
 Davaine M., report on the new fixing and developing agent, by, 171
 Dead eye, image on retina of, 444, 467, 535
 Decimal system of weights and measures, the, 326
 Decomposition of collodion, by Dr. Van Monckhoven, on the, 198
 Decomposition of tannin plates, on the, by Stephen P. Leeds, 112
 Decomposition of water by heat, 304
 Density, excess of, in iodide of mercury, negatives, 37
 Deposit, crystalline, on negatives, 119
 Description of certain dry processes, Dr. Kemp's, 302
 Despratz l'Abbé, dry and wet, collodion, 100, 188, 259
 Developer, formic acid in the, by H. Cooper, jun., 279
 — formic acid in the, 218, 301, 398, 454, 466, 477, 490
 Developing and intensifying, by J. C. Leake, jun., 280
 — the photographic negative, by Aug. Testelin, on, 159, 290
 Development, 379
 — ammonia, 2, 120
 — by the fumes of ammonia, by Alfred Verity, 163
 Development and intensification of the negative image, by Valentine Blanchard, on the, 208
 — spontaneous, 225
 — with formic acid, by Dr. Van Monckhoven, 196
 — with pyrogallie acid, by Abbé Laborde, 220
 Developer, uranium, 18
 Dialysis, 296
 Difficulties of line toning, by J. Hughes, 364
 — printing, 43, 51, 64, 75, 87
 — the line toning bath and its, 358
 Difficulty in the tannin process explained, a, 418
 Diorama and photography, 257
 Direct image on tannin plates, 191
 — intensifying, on a process for, 96
 — photographic printing on paper, on some new principles of, by M. Poitevin, 124
 — positives on albumenized paper, printing, toning and fixing, 474
 Discoloured, to prevent silver baths from becoming, 83
 Discoveries, photographic, 431
 Discovery of alkaline development, the, 491
 — of metal thallium, the, 38, 371
 Discoverer of the use of bromine, and photography, a few facts and an appeal, by Jabez Hughes, 593, 610
 Dissection on art-photography, 95
 Disideri, M., the aesthetics of photography by, 330, 343, 353
 Disgrace to photography, a, 396
 Dissolved glass, affinity of water for, 304
 Dissolving when varnished, the collodion film, 313
 Distortion, photographic lenses and, 574
 District surveyor, glass house, 539
 Doings of the sunbeam, 345, 354, 868, 381, 390
 Double printing, by R. Harmer, 243
 — printing, 285, 601
 — a hint on, 601
 — by the Rev. S. Miller, 405
 — sulphate developer, 120, 219, 263, 300, 359, 377
 Doubtful likeness, the, 539
 Dozen brief hints to portraitists, 509
 Dry and wet collodion, by l'Abbé Despratz, 100, 188, 259
 — collodion, Alphonse de Brebisson's treatise on instantaneous, by M. Ernest Saint Edme, 603
 — collodion and dry processes, by Dr. D. Van Monckhoven, 292
 — M. Liesegang on Mr. Keene's process, 258
 — the tannin process, by G. de Vylder, 377
 — process, rapid, 505
 — colours for paper prints, 516
 — plates, spots on, 155, 167
 — iron development for, 130
 — instantaneous, 474
 — about, by J. M. Saunders, M.D., 343
 — trouble, 311
 — processes, dry collodion, &c., by Dr. D. Van Monckhoven, 292
 — rapid, by T. Sutton, 318
 — weather, want of intensity in, 407
 Durability of gatta-percha transfers, 491
 EARLY photographs, the recently discovered, 541, 557, 575, 600
 Earthquake, the, 491, 504
 Effulgence of water, 304
 Ebonite baths, 371, 383
 Eclipse of the 17th May, the, 252
 Economy of toning, by J. H. Lawyer, 462
 Eden's microscopic camera, 187, 428, 467, 478, 503
 Edme Ernest Saint, Alphonse de Brebisson's treatise on instantaneous dry collodion, by M., 603
 Effects in photography, emulative, 395
 — of light on animal life, 275
 — of washing plates, 177
 Eisteddvd, photography at the, 491
 Electric light, cheap battery for the, 526
 Electric light, 611
 — for portraiture, 616.
 — photometric value of the, 508
 Electrical theory of photography, by John Johnson, 139
 Elements of photography, 325
 Elevation, actinic conditions at a high, 442
 Enamel papers, 168, 276
 — transfers of the, 408
 — photographic papers, the, 217, 239, 242, 276
 Enamelled and tinted papers for photographs, 133, 195
 — photographic paper, by L. M. Leish, 230
 Encyclopedique de photographie, Repertoire 123
 England's formule, Mr., 222
 Eugland, Mr., recovery of gold and silver from waste photographic materials, by, 234
 English amateur's glance at French photography, an, 394
 — lake scenery, stereographs, 519
 — photography in France, 239
 — portraiture, the triple v. the globe lens, 466
 Engraving, new process of, 571
 — photographic printing and, by William Crookes, F.R.S., 483
 — photographic piracy of, 31, 175, 214, 218, 224, 236, 239
 Enlarged copies of photographs, micro-photography, or the art of taking, 293
 — negatives, 75
 — of microscopic objects, 294
 — pictures of photographs, micro-photography, or the art of taking, 378
 — photographic transparencies for ornamental windows, by Dr. Taylor, 197
 — photographs, new light for, by M. Mc A. Gaudin, 555
 — the negative for, 378
 Enlarging, copying and, by A. Maenab, 184
 Enlarging with Stanhope lens, 107
 Enlargement, artificial light for, 611
 — tannin negatives for, by M. Julheit, 426
 Ewing, James, on the manipulation, developing, and intensifying negatives, by, 76
 Evard Blanquart, M., art in photography, 281, 306
 Excess of density in iodide of mercury negatives, 37
 Exchange Club, the photographic, 434, 506
 Exhibition of coloured flames, 3
 — international, 7, 20, 33, 45, 57, 105, 118, 129, 166, 227
 — the photographic, 24, 25, 37, 50, 63, 81, 86, 98, 108, 110, 129
 Expeditious method for the comparison of photographic substances, by M. Mc A. Gaudin, 125
 Experiment, pinholes, 549
 Experiments by V. Blanchard, lime toning, 318
 — toning, black tones, 265
 — with iodides and bromides in collodion, 217
 — with pure chloride, bromide, and iodide of silver, 531
 Exposure, formula for determining, 395
 Extract the silver out of old hypo baths by means of metallic zinc, 215
 Eye, light only exists in the, 550, 370
 Face for portraiture, the best side of the, 144
 Fading cause removed, 239
 Failure in printing, hints on success, 463
 Faithful shepherdess, the, 219
 False claims in regard to medals of the international exhibition, 405
 Fancy, double or, printing, by R. Harmer, 243
 Few words on portraiture, A, 295
 Field, stereoscopic manipulation in the, 332
 Films transferring, 347
 Fine art, photography as a, by W. D. Clarke, 239, 272
 Finished negatives, nature and constitution of the, 71
 Fixing, printing, toning, and direct positives on albumenized paper, 474
 Flat baths, 275
 Fogging nitrate baths, 238, 359
 Foreign science, 8, 21, 34, 46, 58, 94, 129, 178, 190, 200, 224, 288, 290, 262, 271, 322, 356, 369, 393, 417, 429, 463, 476, 490, 523, 538, 550, 586, 597
 Forgery, application of the stereoscope to detect, 310
 — by photography, 420
 — of bank notes, how to prevent, 323
 — and photography, 335, 564, 588
 Formation of a photographic image, on the, by M. M. Ommegeuck, 41, 146
 Formic acid, 218, 277, 301, 324, 398, 413, 454, 466, 477, 490
 — by Z. M. Godinus, 335, 436
 — on development with, by Dr. Monckhoven, 196
 — by H. G. Cooper, jun., 229, 279
 — by K. Staunton, 256
 — preservative, pyrogallie acid, 551
 Formula, collodion, 111
 Fraudulent chloride of gold, 526, 527
 France, English photography, 239
 French international copyright of photographs, English and, 134
 — photographic exhibition, 82, 117, 325
 — photography, an English amateur's glance at, 394
 Fry, Samuel, photography, its retrospects and prospects, by, 27
 Fuchs, Dr. F., the preparation of collodion, by, 320

- Fuming albumenized paper with ammonia, 85, 322, 479
- Fuming sensitive paper with ammonia, by Geo. S. Penny, 158
- GAMBERT *v. Bull*, 224
- *v. Hall*, 31
- *v. Schater*, 173
- Garneri, Sig., photogrammetry, by, 389
- Garrotter, the, 119
- Gaudin, Mr. Mc A., expeditious method for the copiarium of photographic substances, by, 125
- iodide of silver in collodion, by, 500
- on iron developing solutions, by, 87
- lactate of silver for the bath, and lactate of iron for the developing solution, 199
- new light for enlarged photographs, by, 555
- on the coagulation of albumen, by, 5
- on the strengthening of collodion negatives, by, 504
- rapid testing of collodion, 520
- the employment of photogenic powders, for printing vignettes and enlarged positives, 556
- new photogen, for portraits at night, 572
- protoacetate of iron as a developing agent, by, 512
- Ghost in the negative, the, 534
- Girard and Davanne, MM., on the action of nitrate of silver upon albumen, by, 53
- Girard, general study of photographic positives, by MM. Davanne, 210
- researches on positive printing, by MM. Davanne ad, 543, 569
- Glaciers, photographs of, 455
- Glaisher's, Mr., and Mr. Spiller, photometric experiments, by Charles Heisch, 316
- note on the result of photometric observations, by John Suiller, F.C.S., 289
- Glasgow Art Union photographs, 527, 529
- photographic association grand soiree, exhibition, and conversazione, 101, 335
- Glass baths, 336
- new process for silvering, 539
- studio, Colonel Stuart Wortley's, 603
- rooms, by W. B. Parker, 606
- — by A. H. Wall, 607
- — by Hellsby and Co., 617.
- for dark rooms, 155, 395
- house, a cheap, 317
- — and district surveyor, 539
- — and lighting, 109, 158
- — the, 283
- room, cheap, 455
- — revolving, 155
- roughing the edge of, 419, 503
- plates, how to clean, 466
- plates, bad, 467, 477
- process, albumenized, by Charles Waldack, 415
- Glass rooms and lighting the sitter, by W. B. Parker, 606
- by A. H. Wall, 607
- Globe and triple lenses, 73, 179
- Glue for inlaying metals, 323
- Gold toning bath, the new, by Rev. J. Miller, 416
- toning bath, with acetate of soda and chloride of lime, 419, 503
- — new and simple method of, 445
- queries on, 455
- fraudulent chloride of, 526, 527
- Goddard relief fund, 612
- Good, Mr., stereoscopic pictures, by, 587
- Grease and impurities, new test for, 376
- Grey vignettes, 587
- Guide to photography, simple and practical, 268
- Gun-cotton, 419
- composition and properties of, by Aug. Testelin, 17
- — how to keep, 83
- Gutta serena transfers, 467, 479, 491, 574
- $\frac{1}{2}$ per prepared with, 9, 81
- preparation of, by Alexander Arnstein, 145
- HALF-HOLIDAY for Photographers, 106, 191
- Hanbury, description of a self-acting washing cradle, 582
- Handbook of volumetric analysis, 518
- Hardwich, the Rev. T. F., 96
- Harman Alfred, proportion of salt in albumenized paper, by, 557
- Harmer R., double or fancy printing, by, 243
- Harmonious colouring as applied to photographs, 16
- Hart F. W., the use of resin, &c., for the reduction of chloride of silver, 594
- Healing art, photography and the, 15
- Heat, decomposition of water by, 304
- Heath's, Mr. Vernon, exhibition, 239
- Heath's, Vernon, formulae, 222
- Heath's photographs, Mr., 371
- Heisch, on Mr. Glaisher's and Mr. Spiller's photometric observations, 316
- Heisch on photographic collodion, 340
- Heliocromy, by Samuel D. Tillman, M.A., 270
- Heliocromy, Researches in, by M. Niepece de St. Victor, 51
- Highley S., the application of photography to the magic lantern educationally considered, 43, 68, 81, 92, 104, 113
- Hints on success and failure in printing, 433
- Hints to operators, 549
- History of carbon printing, 445
- Holiday, photographic, 106, 191
- Hooper, monument to Bishop, 334
- How to clean glass plates, 406
- How to find the point where the lens is to be placed, 294, 374
- How to mount card pictures, 235
- How to take enlarged negative of a microscopic objects, 294
- Hughes, Jabez, a tribute to amateurs, by Mr. 567
- the difficulties of lime tone, by, 364
- the discovery of the use of bromine in photography, a few facts and appeal, 593
- Hull, C. W., on a photographic trouble, 462
- Hurst, Josh. S., the tannin process, is it slow or rapid, 602
- Huines, Professor C., a word about toning, by, 187
- Hydro-bromic acid, preparation of pure, special precautions to be taken, 26
- Hyposulphite of soda, 480
- ILLUMINATING a laboratory with yellow light, 3
- Illuminations, photographic, 167
- Illustration, photography for, 491
- Illustrations, photographic, of Clonmel, 519
- — pictures and, 452
- — of the Lady of the Lake, 328
- Image on the retina of dead eye, 444, 467, 535
- on stone, various methods of obtaining an, 414, 499
- the development and intensification of the photographic, by Valentine Blanchard, 208
- formation of a photographic, &c., by M. Ommeganck, 41, 146
- spontaneous development of the collodion, 225
- the photographic, 564
- Imperfections in albumen prints, 166
- Importance of photography, the, 447
- Improved solar camera, 205
- spectroscope, 254
- Impurities in alcohol, 309
- — the nitrate of silver, 335
- new test for grease and, 376
- Increasing or reducing intensity of varnished negatives, 241
- the sensitiveness of wet collodion plates, by Thomas Sutton, B.A., 269
- India, photography in, by W. H. Warner, 548
- varnish for, 419
- India-rubber paper, 23
- Influence of photography, the, 282
- sulphate of silver in bath, 210
- Infringement of copyright in photographs, 601
- Insensitive patches on resinized paper, 228
- spots in tannin plates, 455
- Instantaneous and other photographs, 122
- dry plates, 47, 336
- photographs on large plates, by Lieut.-Col. Stuart Wortley, 76
- photography, landscape, and, by W. H. Warner, 230, 251
- pictures, 284
- portraiture for children, 228
- views of Loudon, 122
- Intensifiers, iron, 205
- Intensifying and developing, by J. C. Leake, jun., 280
- process, 332
- Intensity, increasing or reducing the, of varnished negatives, 241
- in dry weather, want of, 407
- International Exhibition, false claims in regard to medals of the, 405
- Invention of the triple lens, 467
- Invisibility of light, 442
- Iodide of silver as a sensitizing agent, and especially of the action of tannin, and some of the oxidizable substances in photography, by A. Poitevin, 578
- Iodide of silver, behaviour of, in the light, 521, 531, 546
- Iodide of mercury negatives, excess of density in, 37
- silver in collodion, by M. Mc A. Gaudin, 500
- Iodides and bromides, 471
- — in collodion, 116, 131, 146
- experiments with, 217
- Iron and ammonia, double sulphate of, 120
- developer, by C. Ommeganck, on the, 339
- the new, 181, 356
- Iron and ammonia without acid, 311, 323
- — developing solutions, by M. Mc A. Gaudin, 87
- — development for dry plates, 130
- — — without acid, 324
- — intensifier, 205, 251, 263
- — printing process, the, 305
- Isle of Wight, 182
- JENNINGS, H. C., jun., the tannin process, short exposure by, 577
- Johnstone, John, on the electrical theory of photography, 139
- Jottings from the note book of a photographer's assistant, 447, 460, 498, 510, 519, 508, 539
- Julliet M., tanning negatives for enlargement by, 426
- Jury, report of the, on photography and photographic apparatus, 7, 29, 33, 45, 57, 105, 118, 123, 166, 227
- KAMBERER, H., on malic and maleic acids as new isomeric bodies, by, 330
- Keene's, dry collodion, M. Liesegang on, 258
- Kemp's, Dr., description of certain dry processes, 302
- Kew committee, report of the, 441
- Kibble, John, chemical experiments by, 136
- Kimball's, H. M., plan, mounting photographs, 608
- improvement in mounting, 608
- King, Warwick W., on the tannin plates, 566
- Klein, Dr., Waldack and Deltenre's portable laboratory, by, 437
- LABORDE L'ABBE, M., on developing with pyrogallic acid, by, 220
- Lacan, Mr. Ernest, scientific photography, by, 398
- — Mr. Cahagnet's printing process, by, 402
- Lactate of silver and iron, by M. Mc A. Gaudin, 499
- Lady of the Lake, photographic illustrations of, 328
- Lake scenery, stereos of, 519
- Lancashire fund, photography and, 12, 216
- Landscape and instantaneous photography, by W. H. Warner, 230
- skies in photographic, 121
- to secure clouds in, by W. H. Warner, 18
- to secure clouds in, 11, 59
- Laudur, carbon printing, by A., 28
- Large plates, on the production of instantaneous photographs on, by Lieut.-Col. Stuart Wortley, 76
- Last century, photography in the, 337
- Lawyer, J. H., the economy of toning, by, 462
- Lead, chromate of, impressions of, Dr. T. L. Phipson, F.C.S., &c., 184
- Leake, J. C., jun., developing and intensifying, by, 280
- Lectures on photography, 107
- on the pistograph, 263
- Leed, Stephen P., on the decomposition of tannin plates, 112
- "Lift" in photographic gallery, a, 611
- Light on animal life, effects of, 275
- Lens in printing, the use of a, 481, 515
- is to be placed, how to find the point where the, 294
- — how to find the point with accuracy where the, 379
- will cover, angle of view, equivalent focus, what a, 357
- Lenses, photographic and distortion, 574
- Lesson, a short, in photography, 64, 128, 147, 161, 173, 235, 341, 462, 513
- Lewis, Joseph, photolithography, by, 403, 414, 449, 461, 499
- Liesegang, M., dry collodion, on Mr. Keene's process, 258
- Liesegang, P., photolithography, by, 426
- Liesh, L. M., enamelled photographic paper, by, 230
- Light, 71
- invisibility of, 442
- new, for enlarged photographs, by M. Mc A. Gaudin, 555
- on bromide of silver, on the action of, by M. Aug. Testelin, 27
- only exists in the eye, 350, 370
- on the measurement of the chemical action of direct and diffuse sun, by K. W. Bansen, for M.R.S. and H. E. Roscoe, B.A., 473
- the magnesium, 327
- the motion of camphor towards the, 190, 285
- upon bitumen and bichromates, the varied action of, 403
- operating rooms for portraiture, a few words in regard, 570
- Line toning baths, 5, 49, 337, 370, 373, 382, 419, 433, 444, 455, 503, 549
- — both and its difficulties, the, 358
- experiments, by V. Blanchard, 316
- — Mr. Parkinson's, 408

- Lime toning, the difficulties of, by Jabez Hughes, 364
 Liquid colours for photographs, 431
 London, instantaneous views of, 122
 — photographic society, 21, 69, 114, 176, 222, 273, 527, 536, 585
 — refiners, reduction of residues by, 587
 Looking glass, to put a positive into a, 18
 MACBETH marks on tannin plates, 460
 Macomb, A., copying and enlarging, by, 184
 Macomb's, Mr., formula, 321
 Macro-photography, or the art of taking enlarged pictures of photographs, 378
 Mactear, Andrew, on photolithography, by, 41
 Magic lantern slides, by H. T. Anthony, 322
 — the application of photography to, by Samuel Hightley, 12, 43, 68, 81, 92, 104, 113
 Magnesium light, the, 327
 Malt process, by F. T. Fassitt, 352
 Malval, M., a new photometer, by, 482
 Malic, on malic acid, as new isomeric bodies, by H. Kaimmerer, 390
 Management of the nitrate bath, 355, 589
 Manipulating box, Mr. Blanchard's, 458
 Manipulation, developing, and intensifying of negatives, on the, by James Ewing, 76
 Marseilles competition, plates for the, 432
 — Photographic Society, 201
 Mayland's formula, Mr., 222
 Meagher's camera, 144, 456
 Measurement of the action of light, 278
 Measuring the angle of photographs, 395
 — the chemical action of the sun's rays, on a new method of, by Dr. T. L. Phipson, F.C.S., London, &c., 439
 Medals, distribution of, 12
 — of the Cornwall Polytechnic Society, 468, 478, 492
 — of the International Exhibition, false claims in regard to, 405
 — of the Photographic Society of Scotland, 216
 Medium on to which negatives may be transferred, new preservative, new transparent, 383
 Meinert Carl, nitrate of ammonia, by, 520
 — an experience with the old hypo bath, by, 123
 Metallic zinc, to extract the silver out of old hypo baths by means of, 215
 Metals, glue for inlaying, 323
 Meyuier, M., new fixing and developing agents, by, 111
 Meynier's, M., new fixing salt, 145
 Microscope, solar, 293
 Microscopic camera, Eden's, 187, 428, 467, 478, 503
 Microscope objects, how to take an enlarged negative of, 294
 Microscopical photography, 491
 Micro-photography, or the art of taking enlarged copies of photographs, 203, 378
 Military purposes, photography in its application to, by John Spiller, F.C.S., 596, 605
 Miller Professor, W. Allen, F.R.S., the most recent spectrum discoveries, 172
 Miller, Rev. S., double printing, by, the, 405
 — photography as an accomplishment, by, 414
 — the new gold toning bath, by, 416
 Millon, E., preparation of sulphocyanide of ammonium, by, 354
 Miniature, on a new kind of, possessing apparent solidity by means of a combination of prisms in contact therewith, by Henry Swan, 427
 Modifications of the tannin process, 253
 Moist sensitive photographic plates, 96
 Monekhoven, Dr., on development with formic acid, by, 196
 — D. Van, theory of photographic processes, 79
 — on decomposition of collodion, 198
 — the new fixing salts, by, 220
 — on the action of photographic varnishes upon the collodion film, by, 233
 — dry collodion and dry processes, by, 292
 — on the collection of residues of silver and gold in photographic ateliers, 547
 Moisture and actinism, 383
 Monument to Bishop Hooper, 384
 Monochromatic dry process, 106
 Moon piracy, the, 167
 Moon, stereographs of the, 107
 Motiloff, Dr. M., process for printing positives without gold and silver, and fixing in water without hypo, 449
 Moulding machine, Bullock's, 108
 Mounting photographs, 239, 516, 539, 608
 Multiplication and enlargement of negatives, 492
 Murder, photograph by and, 226
 NATIONAL portrait gallery, a photographic, 380, 452
 Nature printing and photography, 103
 Neat mode of washing sensitive plates, 304
 Need, a case of, 383
 Negative transfers, gutta-percha, 467, 479, 574
 — on developing the photographic, by M. Aug. Testelin, 159, 290
 — nature of, by J. W. Osborne, 71
 Negatives, on manipulation of, by J. Ewing, 76
 Neutralizing the toning bath, 205
 New and simple method of gold toning, 445
 — exhibition, 81
 — fixing agents, practical notes on the, by G. Wharton Simpson, 206
 — fixing and developing agents, by M. Meynier, 111
 — salt, M. Meynier's, 145, 482
 — the, by Dr. Van Monekhoven, 220
 — report of the, presented to the French photographic society, by M. Davanne, 171
 — iron developer, 181
 — members of the Photo. Society, 551
 — phases of photography, 599
 — principles of direct photographic printing on paper, by M. Pontevin, 124
 — process for positive printing, by M. Bertrand, 101
 New spectroscope, 278
 Newspapers, book packets and, 59
 New York, photography in, 154, 310
 Next year's photographic exhibition, 397
 Nichols, remedy for cracked varnish, 81
 Night, new photogen for obtaining portraits at, by M. Me. A. Gaudin, 572
 Nitrate of ammonia, by Carl Meinert, 520
 — bath, fogging, 238, 358
 — on the management of, 385, 589
 — of silver bath, the, 159
 — upon albumen, on the action of, by MM. Davanne and Girard, 53
 — of soda in albumenized paper, 408
 — in the printing bath, the use of, 498, 598, 610,
 Nitric acid, 435
 Nitrogen from water, possibility of separating, 304
 Non-actinic weather, 335
 North London Photographic Association, 56, 105, 152, 215, 261, 475, 524, 572
 North Wales, views in, 122
 Norway, memorandum of a photographic trip in, by the Rev. Arthur Cotton, M.A., 53
 Notes and Queries, photographic, 11, 23, 47, 59, 71, 83, 106, 119, 143, 155, 167, 191, 203, 239, 263, 275, 299, 311, 323, 335, 346, 353, 371, 383, 395, 407, 419, 431, 444, 455, 467, 479, 491, 503, 515, 526, 551, 563, 575, 598, 611, 617
 Note book of a "Photographers Assistant," jottings from the, 447, 460, 493, 510, 519, 568
 Notes on the collodio-albumen process, by W. D. Clarke, 247
 Nottingham, private photographic exhibition at, 49, 83
 Novel use of eard pictures, 384
 Noverre, L. S., the double sulphate of iron and ammonium as a developer, 219
 — William L., how to print in skies from separate negatives, by, 179
 — W. L., the manufacture of photographic collodion, by, 434, 490, 499, 471
 OMTREARY, 458, 575
 Obtaining a printing surface, various methods of, 449
 Oil for troubled water, 551
 Old hypo bath, an experience with the, by Carl Meinert, 123
 — baths, to extract the silver out of, by means of metallic zinc, 215
 — iron developer a new, 358
 — photographs, the, 600
 Ommegauek, M., on the formation of a photographic image, &c., 41, 146
 — C., strengthening negatives, by, 160
 — on the iron developer, by, 339
 — auro-epnic toning bath, by, 472
 — on toning paper positives, 581
 Opaque, is anything, 350
 Open air, amateur portraiture in the, 119
 Operating rooms for portraiture, a few words in regard to lighting, 570
 — room, yellow varnish for the windows of an, 427
 Optical illusions at the polytechnic, 60
 Organic matter in water, estimation of, 3
 Ornamental photographic border, 320
 Outline in art, no, 95
 Oxide of silver prints, by F. F. Thompson, 500
 Oxygen from bromine, 304
 PAINLESS, the chemistry of, 508
 Paisley photographic society, 120
 Panoramic photographs on flat plates, 130
 Paper positives, on toning, by C. Ommegauek, 581
 — prints, dry colours for, 510
 Paris, photography in the exhibition, 325, 383, 349
 Parker, W. B., glass rooms and lighting the siter, by, 606
 Parkinson's lime toning, Mr., 498
 Past year, photography during the, 1
 Patent albumenized paper, 324
 — laws, the, 479
 — process for permanent printing, Mr. Pouney's new, 367
 Paper discolouring, to prevent, 514
 Penny, George S., fuming sensitive paper with ammoniac, by, 158
 Peraubulating tent, 527
 Permanent printing, Mr. Pouney's new patent process for, 367
 Phenomena produced by the refractive power of the eye, by A. Claudet, 442
 Philadelphia photographic society, the, 115, 153, 202
 Philosophy of the toning process, by John Spiller, F.C.S., 315
 Phipson, a spirit photograph, by Dr. T. L., F.C.S., &c., 28
 — Dr. T. L., Impressions on chromate of lead, by, 184
 — Dr. T. L., F.C.S., London, &c., on a new method of measuring the action of the sun's rays, by, 439
 Photergimetry, by Sig. Garueri, of Turin, 389
 Photo block-printing, 521, 461
 Photodiaphanic, 515
 Photo-electric engravings, and observations upon sundry processes of photographic engraving, by Duncan Dallas, 439
 Photo-engravings, 263
 Photogen, new, for obtaining portraits at night, by M. Me. A. Gaudin, 572
 Photogenic action at different altitudes, 195
 — powders, for printing vignettes and enlarged positives, by M. Me. A. Gaudin, the employment of, 556
 — properties of thallium, 444
 Photographer's rambles, a light tripod, 478
 Photographic exhibition, next year's, 397
 — glauce at Melrose fountains, North Wales, &c., by the Rev. C. Browne, M.A., Emmanuel College, Cambridge, 350
 — illustrations of the Lady of the Lake, 328
 — printing and engraving, by William Crookes, F.R.S., 483
 — poisons, the sale of, 314
 — reproduction of pictures, 346
 Photographs in the last century, 337
 — in printing ink, 613
 Photography and bad taste, 174
 — art in, by M. Blanquart Evraud, 281, 306
 — as a fine art, on, by W. D. Clarke, 259
 — a short lesson in, 54, 125, 117, 164, 173, 239, 341, 462, 513
 — during the past year, 1
 — in a gale, 599
 — influence of, 282
 — in Paris, the exhibition, 325, 338, 349
 — in the police court, 6
 — its retrospects and prospects, by Samu. I. Fry, 27
 — the diorama and, 257
 — in connection with art, on, by the Hon. Lieut.-Colonel Stuart Wortley, 496
 Photolithography, 134, 384, 443
 — by Joseph Lewis, 463, 414, 419, 499
 — by P. Liesegang, 426
 — Mr. Asser's process of, 12
 — on, by Andrew Mactear, 41
 Photometer, a new, by M. Malval, 482
 Photometric observations, notes on the result of Mr. Glaisher's, by John Spiller, F.C.S., 289
 — Mr. Glaisher's and Mr. Spiller's, by Charles Hensch, 316
 — value of the electric light, 508
 Photo-paprygraphy and photo-zincography, 347
 Photo-sculpture, Willeme's, 333
 Photo-zincography, 13, 156, 436
 — and photo-paprygraphy, 347
 Picture gallery, a curious, 369
 Pictures, instantaneous, 284
 — apparatus for viewing, 321
 — and illustrations, photographic, 452
 — photographic reproduction of, 346
 Pinholes and varnish, an artist in trouble, help wanted, 464, 519
 — one of the causes of, in negative, by J. W. Swan, 512
 Piracy, new mode of, 47
 — photographic, 59, 71, 132, 261, 275, 552, 563, 601
 — of engravings, 31, 175, 214, 218, 224, 236, 239
 Plain paper, carbon prints on, 485
 Plate-cleaning preparation, 300, 323
 — holder, simple, 203
 Point where the lens is to be placed, how to find with accuracy the, 379

- Sulphocyanide of silver, to light, sensitiveness of, 263
- Sulphocyanides, preparation of, 482
- Sunbeam, doings of the, 345, 351, 368, 381, 390
- Sun's rays, a new method of measuring the chemical action of the sun's ray, by Dr. T. L. Phipson, F.C.S., London, &c., 439
- Sutton H. A., Thomas, increasing the sensitiveness of wet collodion plates, by, 269
- Esq., on some of the uses and abuses of photography, by, 65
- on art photography, by Alfred H. Wall, 99
- rapid dry processes, further details, by, 318
- Sutton Thomas, rapid tannin plates with alkaline development, by, 489
- B. A., the collodion processes—wet and dry, by, 16
- Sutton Francis, analysis of the silver solutions used in photography, by, 523
- Sutton's patent albumenized paper, 108
- Swan Henry, on a new kind of miniature, possessing apparent solidity, 427
- Swan J. W., one of the causes of pinholes in negatives, by, 512
- TALK in the studio, 12, 24, 60, 72, 84, 96, 108, 120, 132, 144, 156, 168, 205, 216, 224, 239, 252, 263, 275, 300, 323, 335, 348, 358, 371, 384, 396, 407, 420, 432, 444, 455, 468, 479, 491, 504, 527, 539, 551, 563, 575, 587, 599, 611, 617
- Tannin, 350
- negatives for enlargement, by M. Julliet, 426
- process, a difficulty in the explained, 418
- plates, alkaline development, mackerel marks on, 469
- direct image on, 191
- process, is it slow or rapid? 577, 602, 616
- plates, insensitive spots in, 455
- process, Major Russell's recent modification of the, 398, 409
- notes on the, by G. W. O., 577
- plates, on the decomposition of, by Stephen P. Leeds, 112
- rapid, 239
- with a bromide only, 156, 193
- process, short exposure, by H. C. Jennings, jun., 577
- plates, want of intensity in, 478
- with alkaline development, rapid, by Thomas Sutton, 489
- process, by W. Warwick King, 566
- dry collodion, the, by G. de Vylder, 377
- recent modifications of the, 253
- report of a process as practised by Colonel Pike, New York, 513
- Tasmania, photography in, 323
- Taylor, Dr., enlarged photographic transparencies for ornamental windows, &c., by, 197
- Telegraphic engineers and opticians, a group of, 519
- Tillman, M. A., S. D., heliochromy, by, 270
- Test paper, alkaline, 119
- Testelin, M. Ang., on developing the photographic negative, by, 159, 200
- composition and properties of gun-cotton, by, 17
- on the action of light on bromide of silver, 27
- Testing of the collodion, rapid, by M. Mc. A. Gaudin, 520
- Thallium, 38, 161, 371
- photogenic properties of, 444, 527
- Theory of the photographic processes, by Dr. Van Monckhoven, 79
- by Voelz, 521
- of the action of light, time of exposure, 510
- Thicken the actino-silver deposit on the collodion film, to, 332
- Thompson, F. F., oxide of silver prints, by, 500
- Three lessous, photography in, 407
- Tinted papers for photographers, enamelled and, 133
- Tinting albumenized prints, 228
- Tints, scenic backgrounds in, 562
- Toning, 239, 446, 462, 475, 545, 549, 569
- an attempt to secure certainty in, 388
- and fixing, printing, direct positives on albumenized paper, 474
- and mounting, 563
- a word about, by Prof. C. Himes, 187
- bath, neutralizing the, 205
- baths, 351
- bath, auro-cupric, by Ommeganck,
- bath, continued use of same, 106
- bath, chloride of lime and acetate of soda in the, 419, 433
- difficulties, printing and, 460
- formula, 265
- experiments, black tones, 265
- operations, 519
- paper positives, by C. Ommeganck, 561
- process, the philosophy of the, by John Spiller, F.C.S., 315
- with gold and lime, 5, 49, 382, 408, 419, 414, 455, 503
- Traite de l'impression photographique sans sel d'argent, 123
- general de photographie, 123
- Transferring the image from albumenized paper to porcelain, 421, 401
- Transfer process, a new, 403
- of photographic pictures, preparing paper for the transfer, 421
- Transferred albumen films, 502
- a new medium on to which negatives may be, new preservative, 383
- Transferring films, 348, 479
- the collodion negative film upon paper, a simple method of, by Dr. Schnauss, 333
- Transfers from enamel papers, 408
- gutta-percha negative, 467, 479, 574
- Transmitted positives, 47, 203
- Transparent colours for photographs, 515
- tracing linen for blinds, 612
- Transparencies for ornamental windows, enlarged photographic, by Dr. Taylor, 197
- Travelling, cameras for, 177
- Treatise on Positive Printing, 182
- Tribute to amateurs, a, by Mr. Jabez Hughes, 567
- Trimming the print, 608
- Triple achromatic lens, by J. H. Dallmeyer, the, 511
- lens, invention of, 467
- the, 540
- the globe and, 179, 466
- Tropical climates, photography in, 237
- Trouble, a photographic, by C. W. Hull, 462
- UNITED STATES, photography in the, 226
- Universal test book of photography, the, 266
- Uranium developer, the, 18
- Use of a lens in producing, the, 481, 515
- Uses and abuses of photography, on some of the, by Thomas Sutton, Esq., B.A., 65
- VALUE of a wide angle in a picture, the, 401
- Variou processes, relative exposures for, 354
- Varnish for India, 419
- negative, 24
- remedy for cracked, 81
- Varnishes, on the action of photographic upon the collodion film, by Dr. D. Van Monckhoven, 233
- Varnished, the collodion film dissolving when, 313
- Verity, Alfred, development by the fumes of ammonia, by, 163
- Victor M. Niepce de Saint, researches in heliochromy, 51
- Views in North Wales, 122
- Vignetted backgrounds, 156
- Vignettes, the employment of, by M. Gaudin, 41
- powders for printing, and positives, by M. Mc. A. Gaudin, 41
- Vogel, Hermann, on the behaviour of iodide, bromide and iodide of silver, to light, and on the theory of photography, 521, 531, 546
- WALDACK and Deltenre's portable lantern, by Dr. Klein, 437
- C., the chloride of calcium, 21, 33
- albumenized glass process, 16, 49
- preparations employed in the collodion process for positives by, 49
- the accelerating effect in collodion, by, 160
- Wall, Alfred H., Thomas Sutton, 199
- art photography, 90
- Wall, A. H., glass-rooms, by, 607
- a few thoughts about photographic societies, by, 486
- Wallis, George, the new art of photography, by, 199, 212
- Want of intensity in tannin plates, 478
- Warner, W. H., landscape and interior photography, by, 230, 251
- on photography in India, by, 41
- War, photography at the seat of, 18
- Warner, W. H., to secure clouds in photography, by, 18
- Washing cradle, description of a, by J. C. S., &c., 582
- apparatus, automatic, 509
- pan, self-acting, 527
- plates, effects of, 177
- prints, 23
- sensitive plates, a neat mode of, 3
- Watt photographs, the, 407
- Weak printing baths, 263, 246
- Weights and measures, the decimal system of, 326
- Werge's plate cleaning solution, 100
- Wet and dry collodion, by M. L. Deprat, 100, 188, 259
- Wet collodion plates, increasing the sensitiveness of, by Thos. Sutton, 489
- Wet collodion, study of, by M. Reade, 2
- Want of intensity in dry weather, 478
- What a lens will cover, angle of view, 357
- What is "a little?" 299
- White lead and zinc white, 350
- Whites of albumenized prints, silver, by John Spiller, 63
- Wholesale piracies, 59
- Wortley Lieut. Colonel Stuart, on the production of instantaneous photographs on large plates, 76
- Wide angle in a picture, the value of, by Widhall's mounting machine, 599
- Willieme's photo sculpture, 378
- Williams's T. R., formulae, 221
- Wimbledon, photography at, 497
- Windows of an operating room, a new method for the, 427
- Winter session of the societies, 54
- Witness box, photography in the, 497
- Wood, photography on, by M. Baroux, 438
- Wortley's, Colonel Stuart, studio, 497
- Wortley, on photography in connection with art, by the Hon. Lieut. Col. Stuart, 497
- Working hours of photographers, 539
- Wounds, collodion for, 539
- Wye, the, its abbey and castles, 497
- Yellow glass in the dark room, suitable for, 480, 515
- Yellow light for laboratory, 3
- varnish for the windows of an operating room, 427, 480
- Zinc white, white lead, &c., 350



END OF VOL. VII.

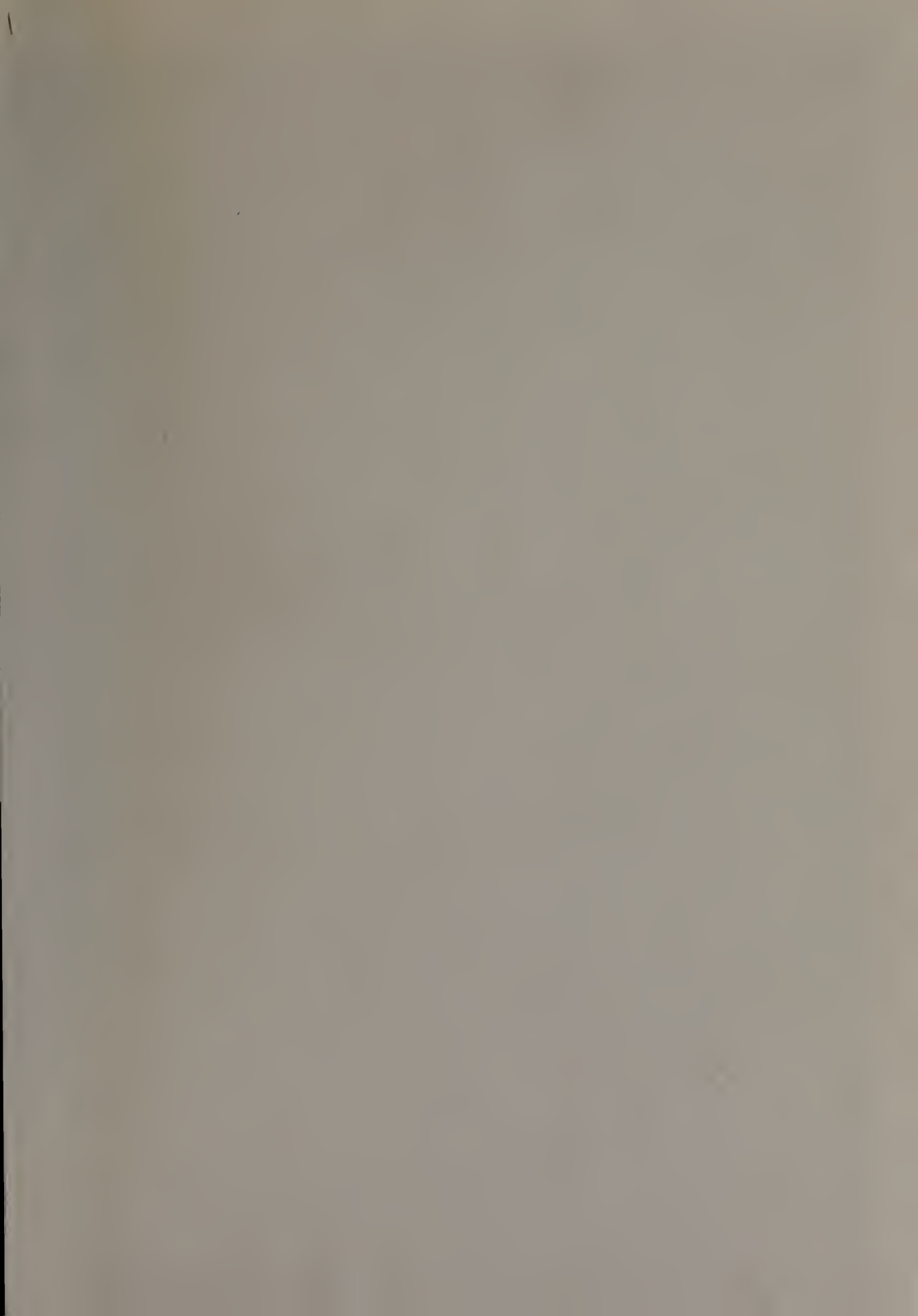

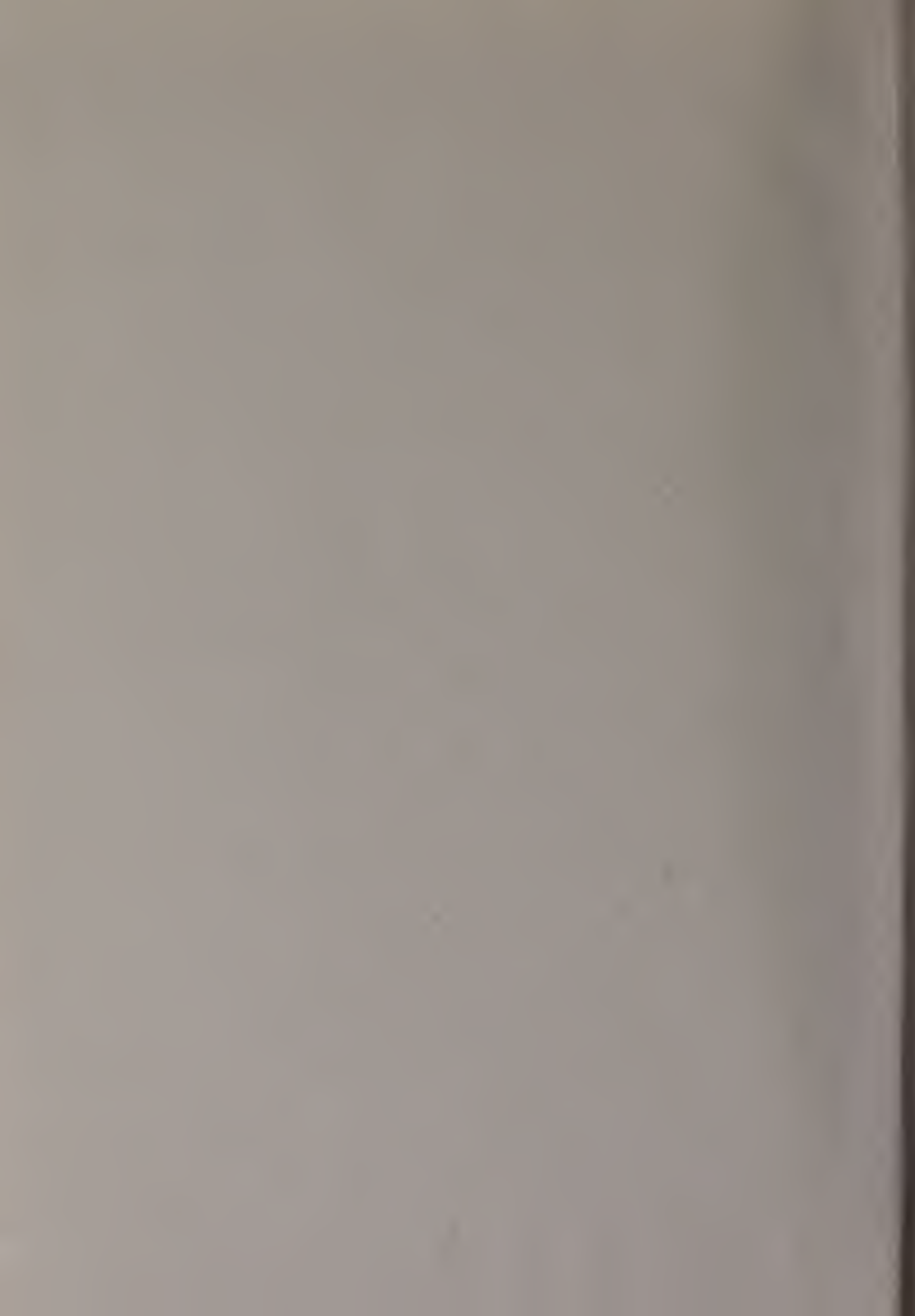



GETTY CENTER LIBRARY



3 3125 00899 1883

