

UC-NRLF

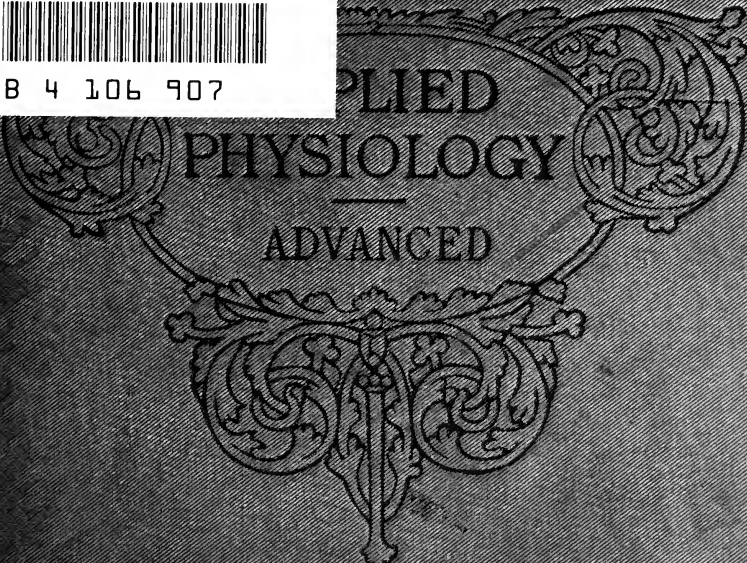

B 4 106 907

A large, ornate decorative frame with intricate scrollwork and floral patterns, surrounding the title text. The frame is symmetrical and has a central vertical element.

APPLIED
PHYSIOLOGY
—
ADVANCED

BY
FRANK OVERTON M.D.

MEDICAL SCHOOL
LIBRARY

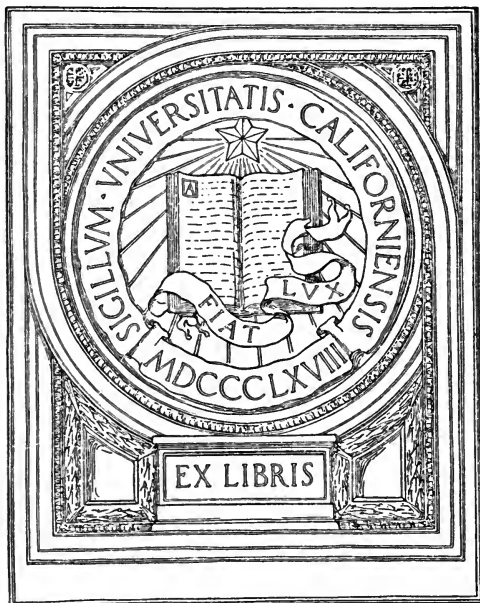

COLLEGE OF PHARMACY

\ Bile partially saponified so
 \ Bile acid in amount
 \ Bile is not a detergent - it
 is a detergent

**CALIFORNIA COLLEGE
of PHARMACY**

Kellcom, man
 Pf. man
 Pf. man

A. L. L.

M. P.
 M. P.
 M. P.
 M. P.

Digitized by the Internet Archive
in 2007 with funding from
Microsoft Corporation





Bones in the hand and wrist.
(From an X ray photograph.)

APPLIED PHYSIOLOGY

INCLUDING

THE EFFECTS OF ALCOHOL AND NARCOTICS

BY

FRANK QVERTON, A.M., M.D.

SANITARY SUPERVISOR

NEW YORK STATE DEPARTMENT OF HEALTH

ADVANCED GRADE



NEW YORK ·· CINCINNATI ·· CHICAGO
AMERICAN BOOK COMPANY

R

COPYRIGHT, 1897, 1908, 1910, BY
AMERICAN BOOK COMPANY

IV. PHYSIOL. (ADV.)

Q. B. 64

Q P 36
096
1910
D

PREFACE

THIS text-book of *Applied Physiology* was suggested by a series of popular lectures in which the author presented the essential principles of physiology about which a physician is consulted daily. His explanations of many common facts were entirely novel to the auditors, and on investigation it was found that the school text-books were silent upon many of these points, especially in regard to the *cells*, where the essential vital functions of the body are carried on. Throughout this book the fact that the cells are the units in which life exists and acts is emphasized.

The author has endeavored to include all the useful points of the older text-books, and to add such new matter as the recent progress of physiological and hygienic science demands. He has avoided technical terms, and has sought to express the truths in simple language such as he would use in instructing a mother as to the nature of the sickness of her child.

The subject of alcohol is discussed in all its aspects. Its evil effects are not exaggerated; but the alleged good from the use of strong drink is contrasted with its dangers in a judicial manner, which appeals to men far more effectively than dogmatic abuse. The relation of alcoholic indulgence to other forms of intemperance, as excessive sugar eating, is also explained.

The essential act of respiration is oxidation within the cells. The relation of oxidation to the disappearance of

food, to the production of waste matters, and to the development of heat and force, is dwelt upon throughout the book.

Many of the demonstrations at the ends of chapters are new. All can be performed without the purchase of a single article of apparatus, except a microscope. The prepared microscopic specimens can be borrowed from a physician.

Most of the cuts are entirely new, and have been sketched by the author from actual specimens. The microscopic appearances of the tissues are especially illustrated. In each cut the illustration of a point, rather than artistic effect, has been the end in view.

The chapter on Repair of Injuries is an entirely new feature in a school text-book. How the body restores its natural functions after injury is as practical and simple a subject as how it sustains itself in health.

The author wishes to express his gratitude to his friend and instructor, Professor William H. Porter, of the New York Post Graduate Medical School, who has given his valuable counsel and encouragement throughout the entire preparation of the work; to Dr. W. E. Gordon, Principal of the Patchogue High School, for his suggestions in adapting the work to the practical needs of the pupils; and to Dr. Thomas E. Satterthwaite, ex-vice president of the New York Post Graduate Medical School, and Dr. William Pepper, M.D., LL.D., ex-provost of the University of Pennsylvania, for their kind criticisms of the proof sheets. Thanks are also due Professor J. O. Lansing for valuable pedagogical suggestions, and to Mr. Robert Cruger for suggestions and aid in the illustrations.

CONTENTS

CHAPTER	PAGE
I. LIVING BODIES AND CELLS	9
II. ELEMENTS OF THE BODY	22
III. OXIDATION	33
IV. FERMENTATION AND ALCOHOL	41
V. DIGESTION OF FOOD IN THE MOUTH	51
VI. STOMACH DIGESTION	66
VII. ABNORMAL ACTION OF THE STOMACH	74
VIII. INTESTINAL DIGESTION	79
IX. ABSORPTION AND ASSIMILATION	89
X. ALCOHOL AND DIGESTION	98
XI. DIGESTION IN LOWER ANIMALS	104
XII. ANIMAL FOOD	107
XIII. VEGETABLE FOOD	120
XIV. QUANTITY OF FOOD REQUIRED	131
XV. DRINKING WATER	135
XVI. NARCOTICS	140
XVII. DRUGS AND POISONS	148
XVIII. THE BLOOD	156
XIX. THE HEART	162
XX. THE FLOW OF BLOOD IN THE BODY	172
XXI. REGULATION OF THE FLOW OF BLOOD	185

CHAPTER	PAGE
XXII. THE LUNGS	192
XXIII. RESPIRATION OF THE TISSUES	206
XXIV. THE AIR AND VENTILATION	220
XXV. HEAT AND CLOTHING	233
XXVI. EXCRETION AND SEWAGE	248
XXVII. THE SKIN AND BATHING	256
XXVIII. NERVES	266
XXIX. THE SPINAL CORD	276
XXX. THE SYMPATHETIC NERVOUS SYSTEM	284
XXXI. THE BRAIN	289
XXXII. INFLUENCES WHICH AFFECT THE MIND	305
XXXIII. EFFECTS OF NARCOTICS UPON THE MIND	315
XXXIV. TASTE, SMELL, AND HEARING	323
XXXV. THE EYE	333
XXXVI. THE VOICE	349
XXXVII. BONES	357
XXXVIII. JOINTS	364
XXXIX. MUSCLES	371
XL. BACTERIA AND DISEASE	382
XLI. REPAIR OF INJURIES	397
XLII. PUBLIC HYGIENE AND SANITATION	405
XLIII. INFECTIOUS DISEASES	416
GLOSSARY	433
INDEX	457

APPLIED PHYSIOLOGY



CHAPTER I

LIVING BODIES AND CELLS

1. **What physiology is.**—The world is composed of living bodies and lifeless matter. In *living* bodies there is a constant change, in which particles become lifeless and are thrown off, while, at the same time, a process of *creation* is going on by which lifeless matter is given life. This constant destruction and renewal of the particles of the body constitutes *life*.

The science which tells of the *structure* of living bodies is *Anatomy*; that which tells of their *working* is *Physiology*; and that which tells how to keep living bodies in good working order is *Hygiene*. The term *physiology* often includes *anatomy* and *hygiene*.

Some processes in man's physiology were discovered only by studying the lower animals; and others, by observing plants. In fact, it is by studying the workings of lower forms of life that most of our knowledge of the working of man's organism has been gained. The physiological processes in plants and animals throw light on the physiology of man because man embodies in his complex system, the same general processes as the lower

forms of life. Only man presents the most perfect combination of these processes.

2. The ameba. — One of the simplest animals lives in stagnant water and is called the *ameba*. It is only a lump of jelly about $\frac{1}{1000}$ of an inch in diameter, yet it is a complete *animal*, for it moves, and eats, and grows, and produces other *amebas*. It has no arms, or legs, or head, but all parts of its body seem very nearly alike. It puts out little fingers from its body and then rolls its whole body into the fingers. In this way it is continually rolling about. When it finds a particle of food it wraps itself around it just as a baker rolls a mass of bread dough around a



An ameba, sketched at intervals of ten seconds ($\times 400$).

raisin. That part of the body which is in contact with the food digests as much as is needed, and then unwraps itself away from the waste. It has no choice as to what part of its body it shall use for any given purpose. But man uses each part of his body for only definite purposes. He has arms which get food, a mouth which eats it, and a stomach which digests it. The arms cannot eat food, neither can the mouth digest it, but each part does only its own kind of work.

3. Man like an ameba. — Each part of a man's body is made of multitudes of living beings, each of which eats and grows like an ameba. Each tiny being is called a *cell*. One collection of cells forms the *skin*, another the *muscles* of the arm, and another the *stomach*, and so on

through the body. Each collection does its own work, without interfering with the others. The cells work together like a well-trained army, so that we do not feel the workings of each separate cell. If a collection is out of order, the person is sick.

4. Cells. — Cells are of various shapes, according to the work they have to do. They are from $\frac{1}{5000}$ to $\frac{1}{100}$ of an inch in length. Each cell is like thick jelly and is almost colorless. Near its center a small mass of slightly different composition may usually be distinguished. This central mass is called the *nucleus*.

The substance composing the cell is like the white of an egg and is called *protoplasm*. Although protoplasm is transparent and jellylike, yet under a microscope there ap-

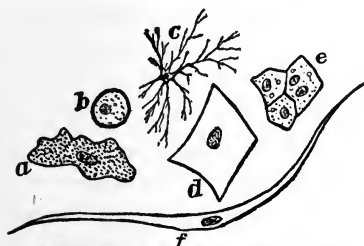

Cells from the human body ($\times 200$).

- a A colored cell from the eye.
- b A white blood cell.
- c A connective tissue cell.
- d A cell from the lining of the mouth.
- e Liver cells.
- f A muscle cell from the intestine.

pears an interlacing series of beads and lines which suggest a structure as complex as that of the body itself.

5. Connective tissue. — The cells are kept in place by a fine network of strong fibers called *connective tissue*. In some parts of the body, as on the outside of the muscles, it is thick and skinlike, but around each



Plants and animals found in stagnant water, each consisting of a single cell ($\times 200$).

there ap-

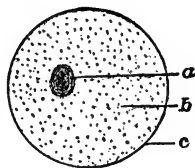

Diagram of the parts of a cell.

- a Nucleus.
- b Cell-body or protoplasm.
- c Covering, generally absent in animal cells.

separate cell there are only enough fibers to keep the cell in place. Even these connective tissue fibers are the threadlike arms of very small cells set apart for the menial work of supporting other cells.

6. Three tests of life.—We know that each cell is alive ; for it moves, it takes in food, and it multiplies.

(1) *Motion.*—Although each cell is held in place by the connective tissue, the tiny particles of its body are in constant motion, just as a boy's eyes and mouth and hands and feet may move, even if he sits still in a chair. Besides this continual motion of the particles within the cell, some cells show a greater motion, in which the cell as a whole takes part. Thus, a muscle cell becomes thicker and shorter when the muscle bends a joint. A white blood cell can force its way through the wall of the blood tube, and can wander about among the cells of the body.

(2) *Nutrition and Growth.*—The blood bathes the cells with food which does not resemble their protoplasm. Each cell takes in the food through any portion of its body, and, endowing it with life, makes it a part of itself. Thus each cell increases in size.

(3) *Reproduction.*—During the period of growth of the body, there is a constant production of the cells ; for the man is composed of more cells than the child. Even in a full-grown man certain cells, as those of the skin, are constantly being shed and new ones formed. When a cell reaches mature life, the nucleus first divides into two parts, which separate from each other ; then the body of the cell divides between the two nuclei. Thus each cell becomes two cells, and each of the two exactly resembles the original cell, except that it is smaller at first ; but it soon grows to be as large as the original cell. All the peculiarities of the life of the first cell go on in each of the two cells into

which it divides; and so we say that the new cell inherits the peculiarities of the parent. This process may be carried on very rapidly; and a new cell may be produced, and itself become divided, in a few hours.

Anything that moves, and eats, and reproduces itself by means of its own power, is alive; and so the cells of the body are alive in the fullest sense of the term.

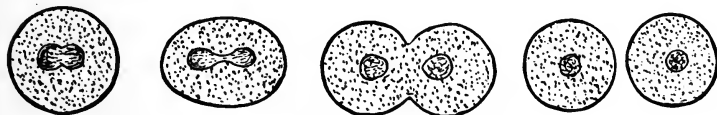

Diagram of the division of a cell.

7. Other distinctions between the living and the dead. —

Many living bodies will show some *spontaneous movement* in response to a prick or a blow, or other irritation. Certain causes, as a low temperature, may suspend the ability to respond to an irritation, but it will return when warmth is applied. A lifeless thing never puts forth effort, no matter how much it is irritated.

Decay never occurs in cells while they live; but after death disintegration soon begins, even if no outside power acts upon the cells. On the other hand, a body which has never been alive usually changes very slowly or not at all, unless acted upon by an outside power.

8. Relation of cells. — In the body formed by the cells there exists a controlling spirit of life, which dominates the whole. When all the cells are obedient to its influence the body as a whole is alive; but if the cells are not obedient, the body as a whole is dead, although each separate cell may remain alive. For example, a blow upon the head may disturb this controlling influence so that it cannot tell the cells how to act. Then they instantly stop work, and the body drops dead. Yet each cell may remain alive for minutes or hours, just as each soldier may remain alive after an army has been disbanded.

9. **Tissues.** — While each cell eats, grows, and produces other cells more or less independently of the rest, yet, like the members of a large family, each works for the benefit of all the others, and, in turn, is dependent upon them for things which it cannot do so well as they. Cells doing special kinds of work are collected in orderly groups called *tissues*. Six kinds of tissues are well marked, —

(1) *Muscular Tissue.* — Groups of ribbonlike cells which have the power of moving the adjacent parts are found everywhere in the body, and form *muscular* tissue. This tissue is usually as abundant as all the rest of the tissues taken together.

(2) *Epithelial Tissue.* — Covering all the surface of the body, and lining every cavity and tube which connects with the surface of the body, is a layer of firm cells which form *epithelial tissue*. It protects the underlying parts and manufactures all the various fluids of the body. From it, also, the hair and nails are produced. Epithelial tissue is abundant and important.

(3) *Nervous Tissue.* — There are cells which control all the others. By means of their long, threadlike prolongations they convey orders to every cell in the body. They and their prolongations form *nervous* tissue.

(4) *Connective Tissue.* — Surrounding each cell, and holding it in place, are the extremely fine arms of small cells called *connective tissue* (see p. 11). Its amount varies greatly in different parts of the body and in different persons, but its total amount is always very large. In some parts of the body, as in the skin and lungs, there is a special kind of connective tissue which is very *elastic*, and gives to the parts their stretching properties. This tissue is called "*yellow elastic tissue*," from its color.

(5) *Osseous Tissue*. — A special form of connective tissue, in which enough *lime* is mixed to make it stiff, is called *bony* or *osseous tissue*. This tissue is rigid and strong so as to form a *framework* for the rest of the cells of the body. A somewhat similar tissue, containing little or no lime, is called *cartilaginous* tissue. It surrounds the jointed ends of bones and often becomes bone late in life.

(6) *Adipose Tissue*. — Some connective tissue cells are arranged in microscopic pockets filled with oil or fat. This forms *fatty* or *adipose tissue*. Most of the fat in the body is stored in this way (see p. 25).

10. The blood as a tissue. — Blood contains two kinds of cells, each of which has a special work to do. Therefore the blood may be called a tissue, even though its cells are floating free in a liquid. The *lymph*, which is mainly diluted blood, may also be considered a tissue.

11. Other fluids in the body. — There are other fluids in the body which, while they contain a few cells, do not depend upon them for their properties or actions and so are not tissues. Into the digestive tube there are poured five fluids concerned in digestion, viz. : the *saliva*, the *gastric juice*, the *pancreatic juice*, the *bile*, and the *intestinal juice*. In order to carry off the waste products of the body two fluids, the *perspiration* and the *urine*, are continually being formed, while water is given off in gaseous form by the breath. Three fluids are found in connection with the eye. Two, called the aqueous and the vitreous humors, distend the eyeball, and another, called *tears*, runs over its surface to wash away dirt. Inside the cavity of each joint is a thick fluid, called *synovia*, which lubricates the surface of the bones within the movable joints. Lastly, *milk* is sometimes produced for the nourishment of the young.

12. Organs. — In order to work to the best advantage, several kinds of tissues are usually associated together. Thus, the stomach, which digests food, is composed of *muscular* tissue which moves the food about, and *epithelial* tissue which pours out digestive fluids, and *nervous* tissue which presides over the process, while *connective* tissue binds the whole together. A collection of different tissues always arranged in a definite, compact shape for a special purpose, is called an *organ*. The *stomach*, *intestine*, *pancreas*, and the *liver* are the four principal *organs of digestion*. The *lungs* are *organs of respiration*, the *heart* is an organ for the propulsion of blood. The *kidneys* and *skin* are organs which get rid of waste matter, and the *brain* is the *organ of thought*. The term organ is also applied to many other parts of the body, but these are the principal ones.

13. Systems. — Sometimes a definite series of tissues and organs are not arranged in compact form, but are scattered through the whole body. This forms a *system*. Thus the system of tubes formed of muscular and connective tissue in which the blood moves is called the *circulatory system*, while the heart is an organ in the circulatory system. In the same way the brain is an organ in the nervous system. The five main systems are the *digestive*, *circulatory*, *respiratory*, *nervous*, and *excretory* systems. In Physiology the action of the cells of each tissue, organ, and system is studied separately. The structure and arrangement of the cells of each tissue are studied by means of a *microscope*.

14. The microscope. — In order to show even the largest cell, a compound *microscope* magnifying at least twenty times is needed; while for ordinary use, one magnifying at least two hundred times is necessary.

A compound microscope consists of two lenses set in a movable tube. The lower lens is called the *objective*, and does the main part of the magnifying. It can easily be removed from the tube or swung aside, and another objective of different magnifying power substituted for it.

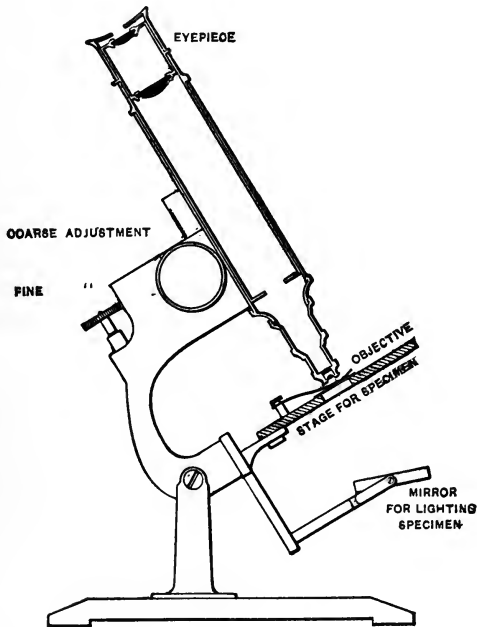

Compound microscope.

The upper lens is called the *eyepiece*. It can be removed from the tube, and another substituted. Usually two or three objectives and two eyepieces of different magnifying powers are furnished with each microscope. A microscope is said to magnify as many *diameters* as the number of times it enlarges the breadth or diameter

of an object. Thus a microscope making a cell appear 100 times as broad as it really is, is said to magnify 100 diameters. But the length and thickness are also magnified. So the surface of the cell is made 100×100 or 10,000 times as large, while its bulk is $100 \times 100 \times 100$ or 1,000,000 times as large. A table accompanying each instrument tells the power of each combination of lenses.

15. Arrangement of the light. — A small mirror placed at the lower part of the microscope throws light through the object, for otherwise there would not be sufficient light to spread over its magnified surface. The mirror can be tilted so as to catch the light from any direction. Objects usually show best when they are lighted only sufficiently to show their outlines. A stronger light may pass through extremely small objects so that they do not show at all. Each microscope usually has a device for varying the size of the aperture in the plate upon which the specimen rests, thus again regulating the amount of light. It is usually not best to use an amount of light which makes the field of view brilliant.

16. Focusing. — The tube carrying the lenses can be moved up and down by means of a small wheel. Arranging the distance of the lens from the specimen is called *focusing*. An objective of high magnifying power must be much nearer to the specimen than one of low power. Thus an objective magnifying 500 diameters must be about $\frac{1}{16}$ of an inch from the specimen, while one magnifying 50 diameters would be over half an inch distant. For high magnifying powers the focusing must be very exact. So a second wheel is provided which moves the tube very slowly. This wheel is called the *fine adjustment* in distinction from the other wheel or *coarse adjustment*. The finger of the observer should always be upon the fine adjustment, turning it back and forth so as to observe now the top and now the deeper portions of the specimen, for it is magnified in depth as well as in breadth.

It is often very difficult to find a very small specimen with a high power lens, for the space in which it lies is magnified to several feet in diameter. A good plan is to use a low power lens for finding the specimen, and then after bringing it to the center of the field, to substitute the high power lens.

Every movement of the specimen is magnified as much as the specimen itself. So great gentleness is needed in moving it under the objective or else it will be moved out of view altogether. The microscope appears to reverse the sides of the specimen, so in order to move the image in any direction the specimen must be moved in the opposite direction. Care should be taken not to press the lens upon the specimen. If the lens becomes dirty or moist it should be gently wiped with a soft, clean handkerchief. A little alcohol rubbed on will aid in removing the dirt.

17. Preparation of specimens.—Specimens are examined upon glass plates, called *slides*. The regulation size is three inches long and one inch broad. Specimens must be very thin, so as to show only a single layer of cells or fibers. A liquid specimen should be a small drop; a powder should be only a tiny speck. A solid specimen is prepared in either of two ways. Its cells and fibers may be picked apart by means of two needles; but this destroys the natural arrangement of the parts. So the method of slicing off extremely thin layers with a sharp razor is more often used. This requires special training. Nearly all specimens should be examined in a liquid. Water will do for nearly all. Glycerine may be used if the specimen is to be kept, for it does not evaporate. A drop is placed over the specimen on the slide. Over the drop of liquid it is well to place a thin piece of glass, called a *cover glass*, for the purpose of protecting the objective from the liquid, and the specimen from currents of air. Air bubbles under the cover glass interfere with the view. They can be forced out by gently pressing upon the cover glass; but with care the cover glass can be applied so as to avoid them. A supply of slides and cover glasses is a necessary part of every microscopic outfit.

A few fibers scraped off from a handkerchief or a few scales from the back of the hand are good specimens for

practice. A tiny bit should be placed upon a slide and a drop of water placed upon it, and the whole covered with a cover glass. Begin to examine it with the lowest powers of the microscope, and so gradually learn to use the higher powers.

SUMMARY

1. Physiology tells how living beings eat and grow and act.
2. The ameba is a tiny lump of living jelly, which eats, and moves, and produces young amebas.
3. The body of a man is made of tiny cells like an army of amebas.
4. Each cell is a lump of thick jelly, in which a small mass called the *nucleus* may usually be distinguished. The cells are held in place by strings called *connective tissue*.
5. Each cell moves, eats, and grows, and produces other cells like the first.
6. The mind lives in the body formed by the cells.
7. The cells obey the mind. When the mind loses control of them the body is dead.
8. Each cell does some special kind of work for the benefit of the rest.
9. A collection of cells doing a special kind of work is called a *tissue*.
10. A collection of different tissues always arranged in a definite and compact shape is called an *organ*.
11. A definite series of tissues and organs scattered through the body for a definite purpose forms a *system*.

DEMONSTRATIONS

1. Scrape the inside of the cheek with a sharp knife and examine a drop under the microscope, with a power of at least 100 diameters.

Notice the flat scales of irregular shape. Each scale is a separate living cell. It is nearly transparent, but its nucleus appears as a slightly darker spot. Make a drawing of the cells.

Examine cells scraped from the skin upon the back of the hand; and cells scraped from the pulp of a leaf. Examine a bit of the green scum, called *pond algae*, which forms upon stones in fresh-water ponds. Notice the long cells joined end to end and containing green matter.

2. Take a drop of stagnant slimy water from a rain barrel or from a kitchen drain or from a stagnant pool. Examine it with a power of at least 100 diameters. A specimen of the ameba is likely to be found rolling about. Notice its nucleus, and also dark spots in its body which are probably food which it has swallowed. Make a sketch of an ameba.

REVIEW TOPICS

1. Define *Anatomy*.
2. Define *Physiology*.
3. Define *Hygiene*.
4. Describe an *ameba*.
5. Describe a *cell*.
6. Describe *connective tissue*.
7. Give the three tests by which a cell or other body is known to be *alive*.
8. Give other distinctions between *living* and *lifeless* bodies.
9. Give the relation of the *mind* to the *cells* of the body.
10. Define a *tissue* and name the different tissues of the body.
11. Show that the *blood* is a tissue.
12. Give the different *fluids* in the body.
13. Define an *organ*.
14. Define a *system*.
15. Describe the *instrument* by means of which the different cells and tissues of the body are studied.

Albumin (building material)
Carbohydrates (Starches + Sugars) Energy
Fats and oils (Energy)
H₂O - (Solvent + Carrier)
Minerals (Na, K-Ca etc)

CHAPTER II

ELEMENTS OF THE BODY

18. **Proximate principles.**—The cells of all animals contain the same substances, differing in amount and arrangement, yet alike in composition. The simple substances of which the cells are composed are called *proximate principles*. The most important proximate principles are water, albumin, fat, sugar, salt, lime, soda, and potash.

19. **Water and solution.**—Water forms nearly three fourths of the weight of the body and is present in every part. It reaches each minute part of the body through the firm walls of the organs. Water has the power of dissolving solid substances, so that they retain all their properties unchanged. Sugar in water is sugar still; in fact, we can appreciate what sugar is only when it is dissolved. When a substance is dissolved in a liquid, so that each remains unchanged in its essential properties, the result is a *solution*. Most solutions will go anywhere water itself will go. In the stomach the food becomes dissolved, and is taken into the blood tubes. The blood contains a solution of food which penetrates into the spaces around each cell, carrying nourishment to the cell and washing away its waste matters. Water makes the tissues limber and slippery, so that they bend and move easily. By means of the perspiration which carries off surplus heat, water regulates the heat of the body. About three quarts of water are taken into the body each day.

Water is composed of two gases, hydrogen and oxygen, very firmly united.

20. Albumin. — The protoplasm of the living cells of the body is almost entirely composed of a substance like the white of an egg. Because it turns white when heated, it is called *albumin* (from the Latin *albus*, white). Pure albumin is hard and brittle as the white of an egg is when it is dry. In the body it is dissolved in from five to twenty times its own weight of water. This solution in water is what is meant by the albumin of the body. In the blood it is liquid, in the flesh it is somewhat jellylike, and in the skin it is strong and tough. It is a very complex body which only plants can form. Animals must get it from vegetables and change it into their own bodies. When once formed it may become part of the bodies of several successive animals, as one makes food of another.

Albumin forms the principal part of the protoplasm of all living cells. Some is used in performing the work of the body and does not reach the cells. About four and one half ounces of pure albumin must be eaten each day to supply the needs of the body.

21. Forms of albumin. — There are many forms of albumin, all having essentially the same properties. The white of eggs is almost pure albumin. Lean meat is composed mostly of another form; cheese, gelatine, and glue are composed mainly of still other forms.

22. Coagulation. — Most forms of albumin may be hardened either by heat or acids, and once hardened they cannot be dissolved again to their original state. A boiled egg illustrates this hardening. Changing a liquid to a jellylike or solid form so that it cannot be changed back to its original form is *coagulation*. Coagulation of its albumin destroys the life of a cell.

23. Putrefaction. — When albumin is kept moist and exposed to the warm air it *decays* or *putrefies*, becoming soft and finally completely dissolving, and at the same time giving off offensive odors. If the albumin is kept dry it shrivels up and finally becomes a glue-like substance. Pure sugar or fat will not putrefy, although both may become sour, but both often contain a slight amount of albumin, and this may putrefy, giving them a slight taste and odor.

notes
24. Diffusion. — When salt and water are placed in a bag of thin skin and suspended in a dish of water, some of the salt and water will pass through the walls of the bag and will mingle with the water in the dish, and, on the other hand, some water will pass into the bag. This will go on until the water in the dish is of the same saltiness as the water in the bag. The act of passing through a membrane apparently impervious is a form of *diffusion*.

Diffusion at the beginning of the process.

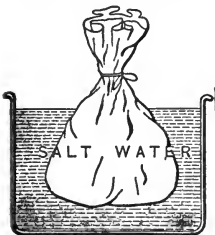

Diffusion at the end of the process.

Without pressure albumin will not diffuse except in the form, called *peptone*, which is produced from the others by digestion. Peptone readily diffuses through the thin sides of the blood tubes in the walls of the intestine, and so reaches the blood.

25. Iron-bearing albumin. — The nucleus of vegetable cells is composed of a form of albumin called *nucleo-albumin*, which contains iron. There are from thirty to sixty grains of iron in the human body, all of which is united with the albumin, so that the metallic properties of the iron are completely absent. A small amount of this iron-bearing albumin is found in the nucleus of every cell, both vegetable and animal, and seems to be essential to the growth and division of the cell. In an animal this substance gives origin to the substance called *hemoglobin*, which forms the coloring

matter of the red blood cells. The iron gives it the power to carry oxygen from the lungs to all parts of the body. Only one or two grains of iron are required each day to supply the loss of the iron in the body, and several times that amount is eaten daily in our food.

26. Fats and oils.—Fats are a series of smooth, slippery substances found in all animals, and in most vegetables. About five per cent of the human body is fat. It is scattered between the cells of all parts of the body, but in places, as in the walls of the abdomen, it forms thick layers. All fats become liquid when heated, but those that are liquid at ordinary temperatures are called *oils*. In the living body fat is always in a *liquid* state, stored in thin-walled pockets made of connective tissue. By boiling, the pockets are softened and the fat runs out upon the water. Each

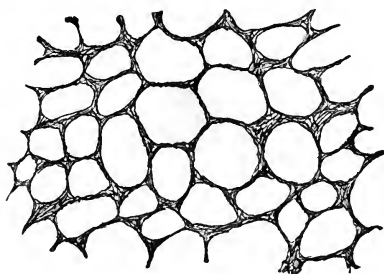

Fat tissue ($\times 100$).

Connective tissue cells form pockets in which the liquid fat is stored.

pocket is from $\frac{1}{500}$ to $\frac{1}{400}$ of an inch in diameter. The fat is produced from the albumin of the cells by a breaking-down process. Fat is a simple substance compared with the complex albumin. Probably all the fat which is stored in the body is made out of albumin.

27. Emulsion of fat.—However much fat may be shaken with water it will remain in tiny particles which soon rise to the surface. If a little white of egg is added, the fat will divide into finer particles and will remain in the water much longer. A mixture of fat and water is an *emulsion*. No emulsion is permanent, but the fat will rise to the surface in time. Milk is the most perfect emulsion, but even in milk the cream, or fat, rises in a few hours.

28. Saponification of fats. — When fat is boiled with soda or potash it is broken up into a small amount of *glycerine* and a large amount of a substance called a *fatty acid*. The fatty acid unites with the soda or potash to form *soap*. When by any means fat is broken up with soda or potash, forming soap, the process is called *saponification*. Both soaps and emulsions are continually being formed during the digestion of fat.

29. Use of fat. — The fat of the body is a living garment, retaining heat and protecting the body from the cold, and rounding out the rugged outlines of the bones and muscles. It is a *cushion*, protecting the internal organs from injury. It is also a *store of food* to be used in sickness when food cannot be eaten. The fat which is eaten is used up in warming the body. Thus fat acts as a *food*, as *armor* for the body, and as useful and ornamental *clothing*. About three ounces of fat must be eaten each day.

30. Starch and sugar. — Starch is produced almost entirely by plants and is stored in the form of little grains

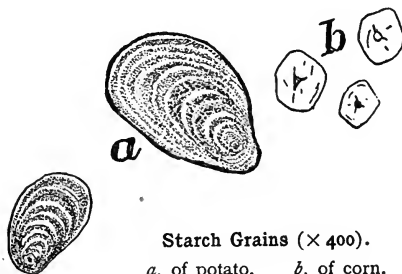

Starch Grains ($\times 400$).
a, of potato. b, of corn.

which will not dissolve in cold water. Grains of potato starch appear like oyster shells and show distinct markings as though they were built up in layers. It is supposed that starch grains grow by deposits

of successive layers of starch between which are layers of a waterproof substance called *cellulose* or plant connective tissue. When the grains are boiled, they swell and burst and then dissolve, forming a paste. As a plant grows, it uses the starch in building up sugar, wood, cotton, cellulose, and other plant substances. Starch, sugar, wood, cot-

ton, and cellulose are similar in chemical composition, but differ widely in character.

Wood is of no use to the body, but starch and sugar are common foods. Starch is changed to sugar before it becomes a part of the body of man. Only a little sugar is found in the body at one time, for almost as fast as it enters it is used up to produce warmth. About five ounces of starch or sugar must be eaten each day.

Minerals. — The minerals salt, lime, soda, and potash, are always found in the body.

31. Salt. — Common salt is found in the bodies of all animals, and a less amount in vegetables also. There are about six or seven ounces of salt in the human body. In animal food there is enough salt to supply the needs of the body, but some must be added to vegetable food. So flesh-eating animals, like dogs and cats, will not eat salt, while vegetable-feeding animals, as horses, like it.

Salt gives an agreeable *taste* to food, and this causes the "mouth to water," and all the other digestive fluids to flow freely, so that the salted food is quickly and easily digested.

Some kinds of albumin in the body will dissolve in water only when salt is present, and if it is diminished in amount, or is absent, these albumins cannot do their work.

Salt *diffuses* very readily, and also aids in the diffusion of all kinds of food. So salt has very important uses in the body, and when it is not used there is great suffering. The proper amount of salt is present in

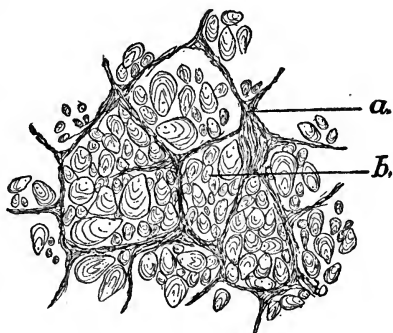

A thin slice of potato ($\times 200$).

- a Albuminous and fibrous pockets.
- b Starch grains in the pockets.

the food when food tastes just agreeably salt. About one half an ounce needs to be eaten each day.

32. Lime. — A small amount of lime is found everywhere in the body, but bone is over one half lime. In all, there are between ten and twelve pounds of lime in the body, but only six grains need be eaten each day. Much more than this amount is found in all common food. The main use of lime is to give *stiffness* to the bones. It is mixed with the cells and fibers of the bone, just as starch is mixed with the fibers of linen to make it stiff.

33. The alkalies—soda and potash.—Some substances are sour and burning to the taste, and can corrode or eat away flesh and metals. When soda or potash is mixed with such a substance, both ingredients in the mixture are changed and a new substance unlike either is formed. For instance, strong vinegar is such a sour, corrosive substance. When soda is added to it the mixture bubbles for a time, and then the liquid is no longer sour or irritating, but has a flat, bitter taste, and both the soda and vinegar have become changed. A substance which is sour to the taste and corrodes metals and flesh, and unites with soda or potash with a bubbling, is called an *acid*. Soda and potash are called *alkalies*. They also can corrode certain substances, but they always unite with acids at the first opportunity, and by their union each is changed to a less harmful form. So alkalies destroy or *neutralize acids*, and acids *neutralize alkalies*.

34. Chemical action. — When two substances are mixed together so that each becomes changed and substances unlike either are produced, the process is called *chemical action*. Sugar will dissolve in vinegar, but it still remains sugar, and so the mixture is called a *solution* (see p. 22). In contrast with it, when soda is dissolved in vinegar it is

completely changed, and so forms an example of *chemical action*. Some substances are very prone to mix to form solutions. Thus, impure salt has such an attraction for water that it takes it from the air and becomes damp. So salt is said to have an *affinity* for water. In the same way some substances are very prone to mix so as to become changed by chemical action. Thus, there is always chemical action between soda and vinegar when they are brought together, so soda is said to have a *chemical affinity* for vinegar. In the same way, *air* has a great "chemical affinity" for *wood* in a fire. The chief value of gold comes from the fact that it has *no* chemical affinity at all except for one or two uncommon substances. So it will remain unaltered in the midst of substances which would destroy other metals.

35. Use of alkalis.—If a fluid contains an acid, it is said to be *acid* in reaction; if an alkali it is *alkaline*; and if it contains neither it is *neutral* in reaction. Now, the blood is always alkaline from the presence of a small amount of soda and potash. Acid products are being formed in the body continually, and the duty of the alkalis is to unite with them at once and change them to harmless substances, which may be handled by the blood in safety. The alkalis are found in nearly all foods.

36. Chemical actions in the body.—Everything which makes up the cells and fluids of the body is composed of some or all the substances—water, albumin, fat, sugar, or starch, with the minerals—salt, lime, and soda and potash. These must be eaten to sustain life, and so they are *foods*. Other kinds of substances are harmful or poisonous. All food substances are eaten three times a day, and yet only water and the minerals leave the body in anything like the form in which they entered. The rest are entirely changed by chemical actions and leave the body as gases or liquids or as solids dissolved in water. The digestion of food from the time it is taken into the mouth

is a chemical action, as is also its becoming a part of the living cells. Breathing and the production of the waste matters of the body are also chemical processes.

These chemical processes can be followed and even imitated in a laboratory. The living principle in the body directs the work, but uses few processes which are not also used outside of the body. It has been a great triumph for science to liberate men from the superstition that the chemical and physical laws of our bodies were governed by the arbitrary feelings of indwelling spirits, and so were different from the laws governing lifeless creatures.

SUMMARY

1. The cells of the body are composed of five substances, viz., water, albumin, fat, sugar, and minerals.
2. Water is three fourths of the body. It carries food to the cells and washes away their waste matters.
3. Albumin is like the white of eggs. It forms the protoplasm of all cells. It warms the body, and gives it strength and weight.
4. Fat is in pockets between the cells. It protects and heats the body.
5. Starch and sugar are similar substances. They warm the body.
6. The minerals in the body are salt, lime, soda, and potash. They are found in all food. In addition some salt must be eaten.
7. Salt aids in the preparation and distribution of food to the cells of the body.
8. Lime stiffens the bones.
9. Soda and potash destroy irritating acids within the body.
10. Water, albumin, sugar or starch, fat and minerals, are foods and must be eaten to sustain life.
11. Most of the vital actions of the body can be imitated in a chemical laboratory.

DEMONSTRATIONS

3. Illustrate the properties of albumin by the white of an egg. Notice its sticky character. Dry some upon a piece of paper over a fire and notice its brittle, gluelike character, and that it will again dissolve in water. Boil some and notice that it becomes hard and will not redissolve. Set some aside and notice that it decays.

4. Inclose a lump of wet flour in a muslin bag and wash it until the water is clear. This removes the starch grains and leaves the grain albumin or *gluten* pure. Notice its tough and sticky character.

5. Show samples of olive oil, lard, and tallow. Show that lard melts at about the temperature of the body, and so is fluid in the body.

6. Shake together some oil and water. Notice that the oil at once floats upon the surface. Now shake the oil with some lime water, and notice that it no longer floats, but that the mixture looks milky, while a few very small oil drops can be seen floating in the liquid. Explain that this is an *emulsion*.

7. Stir together some castor oil and caustic soda, gently heating the mixture, and notice that it forms soap.

8. Scrape a potato into a basin of water. Wash it about and notice that the shreds of potato will float, while a white substance will settle to the bottom of the basin. Explain that this substance is *starch*, and that our great-grandmothers used this method to make starch for laundering.

9. Place a small drop of the wet potato starch upon a glass slide and examine it with a power of at least 50 diameters. Notice that the starch grains appear like oyster shells. Examine also some corn starch and notice that each grain looks like an irregular cube with a star-shaped center. Sketch the starch grains.

10. Boil some starch and notice that it swells and forms a jellylike paste.

Iodine turns starch blue. Apply a drop of the tincture of iodine to the starch and notice the blue color. Apply it to bread, cake, flour, etc. Notice the blue color, showing that they all contain starch. Notice that meat does not respond to the test.

11. Show specimens of sugar. Brown sugar is the impure form, while granulated sugar is the pure crystallized form. Show some sugar scraped from the outside of raisins and explain that this is glucose or grape sugar, and that all sugar and starch must be changed into this form before it can be used by the body.

12. Burn some bread or meat and save the ashes. The ashes represent the mineral part of food, and consist mainly of lime, salt, soda, potash, and iron.

13. Show diffusion by tying a piece of parchment over the end of a large glass tube. Fill the tube with salt and water and immerse it in a jar of fresh water. In a little while the liquid will rise in the tube, while the water in the jar will begin to taste salt. The process will continue until the water in the tube and in the jar are of equal saltiness. If the water in the jar were renewed, all the salt could be extracted from the tube.

14. Show the affinity between acids and alkalies by dropping soda in vinegar. Notice that the mixture boils and foams, and both substances become changed. Drop some soda in water and it simply dissolves and forms a *solution*.

15. Drop a pinch of baking soda in a small cup of water. Then stir in some dilute hydrochloric acid, drop by drop, until the mixture ceases to bubble. Taste the mixture and notice that it is salt. Explain that the hydrochloric acid and the soda have formed a chemical combination and each has neutralized the other. The new substance formed is *chloride of sodium* or common salt.

REVIEW TOPICS

1. Define and name the *proximate principles*.
2. Describe *water* and define a *solution*.
3. Describe *albumin*.
4. Describe *diffusion*.
5. Describe *putrefaction*.
6. Describe *nucleo-albumin*, and its relation to *iron*.
7. Describe *fats* and *oils*.
8. Describe an *emulsion*.
9. Describe *saponification*.
10. Describe *starch*, *sugar*, and *wood*.
11. Describe *salt*.
12. Describe *lime*.
13. Describe the *alkalies*.
14. Define *chemical action* and *chemical affinity*.
15. Name some chemical actions in the body.

CHAPTER III

OXIDATION

37. **The nature of burning or oxidation.** — In addition to the substances taken in as food, the body is continually taking in *oxygen* by the breath. The air which is breathed is four fifths nitrogen gas and one fifth oxygen gas. When air is fed to fuel in the hot fire box of a boiler, burning takes place. Burning is a chemical process. Oxygen unites with the carbon and the hydrogen of the wood, so that both the wood and the oxygen disappear. The carbon and part of the oxygen form *carbonic acid* gas. The hydrogen and the rest of the oxygen form *water*. Both substances pass off in the smoke. What is left as ashes is the *mineral* part of the wood.

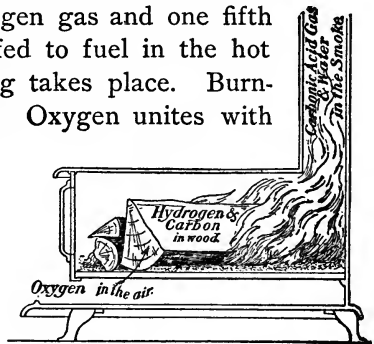

Diagram of burning or oxidation in a stove.

By the burning, heat and a flame are produced. The heat can be used to make steam which will drive an engine and do work. Burning is called *oxidation*.

38. **Oxidation within the body.** — The body also is an *engine*, — self-regulating and self-sustaining. The oxygen which is breathed into the body slowly burns *food* and the *cells*, just as it oxidizes the wood under the boiler of an

engine. The process goes on so slowly that no flame is produced, but the same amount of heat is produced as though the same substances were burned in a furnace. Some of this heat is used to warm the body, and some is changed to power which enables the body to do work, either of motion, or of manufacturing the various products of the body or of thought. Oxidation is an essential process of life; when it ceases for an instant life ends. When the air is cut off from the body for only a minute, a great feeling of suffocation comes on, and within two or three minutes the body dies.

Oxidation goes on in each cell, but especially in the cells of the lungs and liver. It is a process of life, and in a living cell it can be hastened or retarded according to the needs of the body.

By the oxidation within the cells of the body, carbonic acid gas, water, and ashes are formed, as in a furnace.

39. Oxidation of albumin.—An ounce of albumin is completely oxidized by an ounce and a half of oxygen. The ashes which are produced are partly the *sulphur* of the albumin and partly the *nitrogen*, which holds some of the carbon, hydrogen and oxygen, combined in a solid called *urea*. Urea must be given off by the kidneys and skin as fast as it is formed. When there is not enough oxygen to burn the albumin entirely, other substances resembling urea are formed, just as a stove smokes instead of burning brightly when the draft is closed. Some of these substances are very poisonous. The albumin of the living cells is probably oxidized and replaced continually. Much of the albumin of the food is oxidized before it reaches the cells.

40. Oxidation of fat.—An ounce of fat is completely oxidized by three ounces of oxygen. So it will produce

twice as much heat as the same amount of albumin, and is thus a good food for cold weather. It leaves no ashes behind, for it contains no mineral matter.

41. Oxidation of sugar.—An ounce of sugar is completely oxidized by one and one fifth ounces of oxygen. So it produces only about half as much heat as fat. It is much more easily oxidized than fat or albumin. When the three substances are mixed together as they are in the body, the oxygen will go to the sugar in preference to the fat or albumin, and the latter two substances being unburned will accumulate in the body. Thus sugar is said to be *fattening*. The water and the minerals of the body cannot be oxidized, but enter and leave the body unchanged.

42. Reconstruction of living material by plants.—In every animal the living cells are continually uniting with the oxygen of the air and giving out carbonic acid gas, water, and mineral matters. From these waste matters plants reconstruct the substances which were oxidized in the body. The first substance produced seems to be *starch*, and from it as a basis all other parts of the plant and of animals are built up.

The plant cells which contain green coloring matter called *chlorophyll*, are set apart for the special work of reconstructing starch from oxidized material. To them the sap brings water from the soil, and carbonic acid gas from the air. In the chlorophyll these substances are recon-

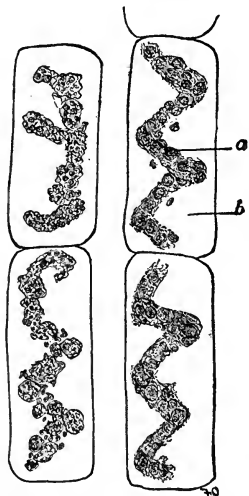

Chlorophyll in pond algæ.

a Chlorophyll arranged in a spiral.

b The clear body of the cell.

structed into starch. Using starch as a basis, plants construct fat and albumin and all other substances found in the plant.

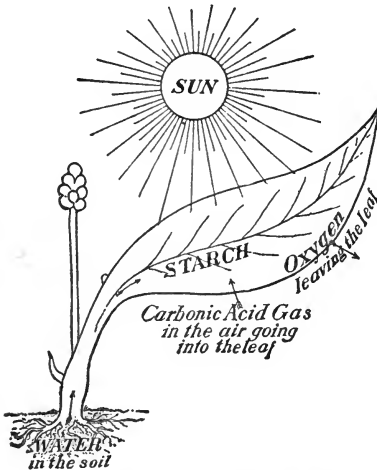

Diagram of the restoration of oxygen to the air after oxidation, and of the rebuilding of burned material into living forms.

carbon and hydrogen to form living starch. Thus the real work of construction is done by the sun. When the starch is oxidized, oxygen goes back to the hydrogen and carbon, and the same amount of heat is given off as was taken from the sun when starch was formed.

The heat of oxidation can be traced back to the sun's heat stored up by living beings or beings once alive. All the carbon of a tree is the carbonic acid gas of the air with its oxygen taken away by the sun's force acting through chlorophyll. Coal is the carbon of trees changed in form during ages of burial.

44. Conservation of energy. — The energy of the sun's heat expended upon the plants in

43. The sun's work in reconstructing living material. — When oxygen unites with the carbon and hydrogen of the burning substances, heat and energy are given out. Just as much heat and force must be used in tearing away the oxygen as was given out during the oxidation. The sun furnishes this heat and force. The chlorophyll acting as the machine and using the sun's rays for power, frees most of the oxygen from the carbonic acid gas and water, and gives it back to the air. At the same time it unites the remaining oxygen with the car-



Diagram of the stream of material flowing through man.

bygone ages was *conserved* in the coal, and now can be made to appear again as *force* in a steam engine. This force may run an electric dynamo, and the electricity can be transported silently over miles of wire, to appear as light rivaling its original source, the sun. Through all its changes the original energy is preserved.

Observation of the three facts, (1) the heat of the sun acting through plants to tear the oxygen from the carbon and hydrogen, (2) the reunion of the substances in oxidation with the development of the original heat of the sun, and (3) the various forms of power into which the energy can be changed, has given rise to the principle that *any form of energy can be changed into another form without loss*. This principle is called the *conservation of energy*.

This principle is exemplified in the human body. The energy for the work done by the body is the *heat* derived from the oxidation of its food.

45. Relation of plants to animals. — The oxygen of the air would all be used up in a few years if it were not continually torn away by plants from its combinations in carbonic acid gas and water. The carbon and hydrogen would also disappear; but the sun and chlorophyll continually renew the supply both of food and of oxygen. Thus there is a stream of material flowing from lifeless soil and air. It becomes alive in the plant and again in the animal, and then is suddenly oxidized to a lifeless form, and given back to the soil and air, only to repeat the round of life. Plants build up living material which animals use as food and then oxidize back to the form in which it existed before the plant touched it. Plants give off oxygen which supports animal life. Each lives upon what the other discards.

46. Organic substances. — Substances which are built up by living beings are called *organic*. Thus the plant takes carbon from the carbonic acid gas in the air, and builds it up into an organic substance, which forms part of the plant.

47. Difference between plants and animals. — (1) The ability to live upon the ordinary waste products of animal life, or, in other words, to *reconstruct organic matter out of crude minerals and gases*, is a distinguishing mark of a plant. On the other hand an animal always requires *organic food*, and cannot live upon the soil and air. Yet the lowest animals very closely resemble plants, and owing to the difficulty of ascertaining the true source of their food the position of some living bodies is still a matter of dispute.

(2) In animals the cells are bound together by strings of *connective tissue*, which is an albuminous substance of *soft* consistency. In plants the substance between the cells has the composition of *starch* (see p. 27). It is a *hard and firm* substance, and gives the rigid strength to the plant or tree. The outsides of the plant cells often have a thick coating of the same substance. When it is deposited in so great an amount as almost to replace the cells the substance forms *wood*. Yet in some plants it is entirely absent, so that the distinction applies only to higher forms of life, where other distinctions between plants and animals are more obvious.

(3) Most animals have the power of *voluntary motion*, while most plants are *fixed* to one spot. Yet some animals, as the coral, have no more motion than a flower which opens and closes during the day. On the other hand some water plants are continually moving about by means of vibrating hairs projecting from their bodies.

Some *plants* also *move* if irritated. The plant called Venus's flytrap has stiff, toothed leaves, hinged together in twos so as to open and shut like a rat trap. When a fly alights upon the open leaf it suddenly closes upon the insect, crushing it to death. This plant exhibits more movement responsive to a slight irritation and directed to a distinct purpose than many true animals.

(4) Most animals have a *digestive tube*, while plants have no organs of digestion, unless the leaves can be called such. Yet in some animals, as the ameba, the body looks nearly the same throughout.

(5) Most plants are *green* in color, from the presence of chlorophyll. Yet many plants, as toadstools, are destitute of chlorophyll.

48. Source of life. — In the oxidation and reconstruction of animals and plants no *new life* is created. Lifeless material is endowed with life by material already living, and in its turn the new material imparts life. The same

life continues through all the changes of the body, although not a single particle of the original body may remain. The body is but the house in which life resides. The original source of life itself has never been found. The Bible gives the only known origin of life:

“And God said, Let the earth bring forth grass, the herb yielding seed, and the fruit tree yielding fruit after his kind, whose seed is in itself, upon the earth: and it was so.

“And the earth brought forth grass, and herb yielding seed after his kind, and the tree yielding fruit, whose seed was in itself, after his kind: and God saw that it was good.” — Gen. 1:11-12.

SUMMARY

1. Oxygen unites with carbon and hydrogen, and produces heat. The process is called *burning* or *oxidation*. A steam engine transforms heat into work.
2. Oxygen from the air is continually entering the body.
3. Within the body it is continually uniting with the albumin, fat, and sugar, and producing heat, some of which is transformed into work. This is the essential process of life.
4. By oxidation, the albumin, fat, and sugar become carbonic acid gas, water, and urea, and are given off from the body.
5. The green coloring matter of plants forms the machine, by means of which the sun's heat tears the oxygen away from the carbonic acid gas and water and forms organic substances again.
6. Plants prepare food for animals, and animals prepare food for plants.

7. All through the oxidation and reconstruction of the body life remains the same, and no new life is created.
8. The Bible gives the only known explanation of the origin of life.

DEMONSTRATIONS

16. Lower a lighted candle into a wide-mouthed bottle. When it goes out pour in a little lime water, then stop the mouth of the bottle and shake it. The water becomes milky, showing that carbonic acid gas has been produced. By means of a straw or glass tube blow a little air through a cup of lime water and notice that again the water becomes milky. This shows the carbonic acid of the breath.

17. Hold a lighted match under a cold tumbler. In a few seconds drops of moisture will condense upon the inside of the glass. Explain that the water is formed by the union of the hydrogen of the match stick with the oxygen of the air.

REVIEW TOPICS

1. Describe *oxidation* and its products.
2. Show how oxidation takes place in the body.
3. Describe the oxidation of each proximate principle.
4. Describe the series of changes by which the oxidized materials of the body are again built up into living bodies.
5. Define and illustrate *conservation of energy*, and apply it to man's body.
6. Define *organic* bodies.
7. Give points of difference between *plants* and *animals*.
8. Give the only known *source of life*.

CHAPTER IV

FERMENTATION AND ALCOHOL

49. **Production of alcohol and vinegar.**— Unless great care is taken to preserve it, a weak solution of sugar soon turns to *vinegar*; a stronger solution turns to *alcohol*, while a thick, sirupy solution remains unchanged. Everywhere there are scattered minute living germs which, falling into a moderately strong solution of sugar in water, grow and produce oval plants each about $\frac{1}{4000}$ inch in length. A collection of these plants is called *yeast*. By their growth and multiplication they change sugar to alcohol and carbonic acid gas. The gas bubbles up through the liquid and makes a froth upon the top, while the alcohol remains in the water.

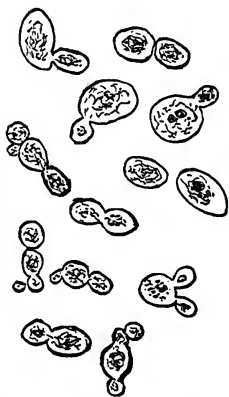

Yeast plant cells ($\times 500$).

If only a small quantity of sugar is present another kind of germ from the air enters and grows, becoming tiny rodlike plants, each about $\frac{1}{10000}$ inch in length. By their growth and multiplication they change the alcohol to vinegar. They collect in a mass called the *mother of vinegar*.

Boiling destroys both the yeast and vinegar germs. If the sugar and water are boiled and at once sealed tightly, so that new germs cannot enter, the solution will keep

for an indefinite time. Fruit when boiled and at once sealed in air-tight cans will keep unchanged for a long time. If there is a great deal of sugar present no germs at all will grow, and the solution will keep indefinitely. This is why fruit can be *preserved* in open jars if a great deal of sugar is used.

50. Fermentation. — Changing sugar to alcohol or vinegar is an example of *fermentation*. A substance which can change the composition of other bodies without losing its own identity or characteristics is a *ferment*. A very small amount of a ferment can change a very large amount of another substance.

A very small amount of yeast will cause an indefinite amount of sugar to become changed to alcohol or vinegar. At the same time the yeast may not grow weaker, but on the contrary may become stronger than at first. In the same way a small amount of "mother" will change a large amount of weak alcohol to vinegar, and itself will greatly increase in amount.

51. Kinds of ferments. — Nature uses many ferments in her actions. Some are living beings and some are lifeless substances. The chief part of the digestion of food is done by lifeless ferments. Fermentation is commonly spoken of as a process of decay, but the common process of decay or rot is in itself only a special kind of fermentation. Ordinary decay is caused by a living being like the vinegar germ. By its growth and multiplication it softens and liquefies the albumin of animal and vegetable matter. This process is called *putrefaction* (see p. 24). Some of the matter passes off as foul smelling gases, while the liquid part soaks into the soil. Putrefaction is nature's way of giving dead bodies back to the soil and air so that plants can build them into useful forms again.

Yeast germs are found everywhere, but they are often grown in wet meal or flour. The mass is then dried in cakes and sold as *yeast*. When a small piece is added to sugar and water it starts alcoholic fermentation at once. Alcoholic fermentation only is usually meant when

the term *fermentation* is used alone. An adjective signifying the special form of fermentation is used to indicate any other form than the alcoholic. Thus there is acetous or vinegar fermentation, and putrefactive fermentation.

52. Bread making. — By the growth of yeast plants in bread dough some of the sugar in the flour is changed to carbonic acid gas and alcohol. The gas bubbles up through the dough, making it porous and light. When the bread is baked, alcohol is driven off and the yeast germs are killed by the heat. They are eaten with the bread, for they are perfectly wholesome. When germs of vinegar or other acid fermentations enter the bread and grow, the bread sours. These germs grow more slowly than yeast, and usually do not have time to develop. But if the bread is a long time in rising, they may grow and make the bread sour.

53. Fermented drinks. — Man uses the same process to produce drinks, which are erroneously supposed by many to act as a beneficial food, quenching thirst and giving strength to the body and power and joy to the mind. There are three classes of such drinks, all containing alcohol as an essential part.

54. Malt liquors. — The commonest form is what is known as *malt* liquors. Barley and other grain are moistened and permitted to sprout until the new stalk is about one half inch in length. This changes much of the starch of the grain to sugar. The sugar is dissolved out by boiling the grain along with hops and various other flavoring substances. Then yeast is added and alcoholic fermentation occurs. The result is *beer*. It contains from one to ten per cent of alcohol. Much of the flavoring which is often added to it is not only injurious, but actually poisonous.

55. Wines.—The second class of alcoholic liquors is *wine*. The juice is squeezed from grapes, blackberries, or some other fruit rich in sugar. Germs of alcoholic fermentation from their skins and the air set up fermentation in the juice and produce wine. Certain localities and cellars contain special kinds of germs which produce a peculiar flavor in the wine fermenting in that locality. In this way different kinds of wine are produced. Wine contains from five to fourteen per cent of alcohol. Fourteen per cent of alcohol in the juice kills the germs and stops the fermentation. So wine cannot contain more than that amount of alcohol unless more is added.

56. Distilled liquors or spirits.—The third class of alcoholic drinks is spirits, or *distilled* liquors. Alcohol boils at a temperature of 170° F., while water boils at 212° F. Thus when a wine, or beer, or any other alcoholic solution is heated its alcohol will be changed to steam very rapidly, while the water will evaporate slowly. Therefore the steam will contain a larger proportion of alcohol than the original liquor. This fact is put to use in separating alcohol from the solution in which it was produced. The steam is conducted through a coil of pipe kept cool by running water. Its temperature is lowered and it is changed back to a liquid form. This new liquid is whisky, or brandy, or other spirituous liquor, according to the substance used in its manufacture. The process of its manufacture is called *distillation*. Spirituous liquors are about one half alcohol.

57. Description of alcohol.—If the process of distillation is repeated the alcohol which passes over is still freer from water, until after three or four distillations it is almost pure. It is then a clear, colorless liquid like water. It has a sharp, sweetish taste and a peculiar odor. It causes a

severe smarting sensation when applied to a raw sore or to the eye or mouth. It is a valuable and useful article when rightly used in the manufactures and arts. But men have formed the bad habit of liking its taste and the feelings which it produces. They drink strong drink solely for the sake of the alcohol which it contains. The alcohol has an injurious effect upon every part of the body. These effects will be described in detail as each organ is studied.

58. Kinds of alcohol. — Alcohol is the name for a series of substances formed out of the same elements, but varying in composition, yet alike in essential properties. The simplest form is called *methyl* alcohol, or *wood spirits*, and is formed by distilling wood. It has an unpleasant odor and taste, but nearly the same properties as common alcohol. It is much used in manufacturing and in the arts, as a substitute for common alcohol, on account of its cheapness.

The next form, called *ethyl* alcohol, is the common alcohol made from wine, beer, etc.

The fifth in the series is called *amyl* alcohol or *fusel* oil, from the German *fusel*, bad liquor. It has a bad odor and nauseous taste, and is far more poisonous than common alcohol. It is formed in considerable quantities when potatoes are fermented. But if the whisky stands for some years, the fusel oil becomes changed to ordinary alcohol.

59. What becomes of alcohol in the body. — When taken into the stomach, alcohol passes into the blood with great rapidity. The body has the power of rapidly disposing of it either by giving it off, or, more probably, by oxidizing it to carbonic acid and water, and thus destroying it. At any rate, little or no alcohol can be found in any part of the body or in its waste, no matter how much is taken. But its oxidation takes place in an irregular way which is injurious to the body.

60. Effects of alcohol. — (1) *Prevents fermentation and decay.* — While alcohol is the product of fermentation, it has the power to *prevent* fermentation. The germs producing alcohol will not grow when alcohol is present in the proportion of 14 per cent. Germs of decay will grow in a much larger percentage of alcohol, but no germs will grow in a solution of one half alcohol. This fact is put to use in preserving specimens of animals and vegetables in museums, by placing them in spirits or alcohol. Since decay is dependent upon germs, the alcohol, by preventing their growth, prevents decay. It can also prevent the digestive ferments from acting upon food.

(2) *Extracts water from tissues.* — Water and alcohol mix very readily. An uncorked bottle of alcohol takes up water from the air, and so becomes weakened. When alcohol is in contact with a wet substance, it appropriates some of its water, and the substance then shrivels and becomes firmer. Strong whisky can produce the same result in the body to a limited extent.

(3) *Hardens tissues.* — Alcohol also hardens many animal and vegetable substances by extracting their water and by *coagulating* their albumin. In museums this fact is put to use in hardening soft and delicate specimens of animals and vegetables, so they may be preserved and examined safely. It is not probable that this action occurs in the body, for nature pours out an abundance of water to dilute the irritating alcohol.

Within the body the effect of extracting water from the tissues and of hardening albumin is to produce a smarting sensation which shows that the organs are being injured. There would be no limit to this action and death would soon take place if nature did not provide means for a partial protection against the substance. When any part

of the body is harmed, nature pours an abundance of water over the injured spot, so as to dilute and wash away the irritating substance, just as she pours out tears to wash a speck of dirt away from the eye. Alcohol attracts water to itself, and thus its power to do harm is greatly lessened. But this protection is only partial. If only a small amount of strong drink is used steadily for some time, nature becomes exhausted in her efforts of defense. Thus, while some exceptionally strong men seem able to use a large amount of strong drink with little harm, most men are greatly harmed by the smallest amounts.

61. Cause of thirst for alcohol. — The property of taking away water from substances which it touches, accounts in part for the failure of alcoholic drinks to satisfy thirst. A dry state of the surface of the lining of the mouth gives rise to thirst. If this lining is deprived of water by an alcoholic drink, the sense of thirst still remains, although the rest of the body is supplied with water. Moreover, this lining is somewhat injured by the alcohol of every drink, and to soothe the irritation another drink is needed. So the thirst goes on, growing stronger with every drink.

When he begins, no drunkard expects to use strong drink, or to drink more than a glass or two at a time, but his thirst always deceives him, and the momentary relief which drink gives him is only a deceitful addition to his thirst.

62. Adulteration of alcoholic drinks. — The manufacture of pure alcoholic liquors is a slow and expensive process. So cheap imitations are made which closely resemble the real article in taste and appearance. Beer is often made from cheap rye or corn and quassia, instead of barley and hops. Its fermentation is often hastened by an excess of yeast, and then the product is preserved by adding salicylic acid or other substances which destroy the yeast.

Whisky and brandy are also much adulterated. All kinds are alike in having a large amount of alcohol. In fact, the cheaper kinds of whisky and brandy contain the most alcohol.

Often, instead of good grain or fruit, rotten fruit, peelings, and refuse of all kinds are used in making liquors. When distilled and treated

with flavorings, a drink is produced which an expert chemist can scarcely distinguish from genuine liquor, and yet its evil effects are notoriously greater.

63. Temperance drinks.—Strictly speaking, water is the only *temperance* drink, for all kinds of flavored and fermented drinks are designed only to please the taste and not to fill a want of the body. The use of any except water is a form of intemperance, but those which contain alcohol are especially harmful.

Cider, root beer, and ginger ale, and other “homemade” drinks which are “worked” or fermented, all contain alcohol, and should be classed as strong drink. These drinks are particularly bad, for their use may lead one to indulge in stronger drinks.

SUMMARY

1. A sirupy solution of sugar will not become sour, but will “preserve” fruit from spoiling.
2. Sugar in a weak solution becomes alcohol.
3. The change is produced by the growth of microscopic plants called *yeast*.
4. Sugar in weaker solution becomes vinegar.
5. The change is produced by a collection of microscopic rodlike plants which form the “mother” of vinegar.
6. Changing sugar to alcohol or vinegar is fermentation.
7. Wine is made by fermenting fruit juice, and beer is made by fermenting a solution of sprouting grain.
8. Distilled liquors are made by boiling fermented liquors and collecting the vapor.
9. Alcohol prevents decay by killing the germs which produce rotting.
10. Alcohol takes water away from other substances and then hardens and shrivels them.

11. Alcohol disappears very rapidly after being taken into the body.
12. Alcohol takes water from the lining of the mouth and produces thirst.

DEMONSTRATIONS

18. Show fermentation by setting aside a bottle containing a little molasses in water. In a few days bubbles will rise, showing that fermentation has begun. Add a little yeast to another bottleful, and notice that fermentation begins within a few hours. Boil another bottleful and at once cork it tightly, and notice that it does not change. Explain that the first bottleful started with few germs and so fermentation at first was slow. The second had many and fermentation began at once. In the third the yeast germs were destroyed and so no fermentation took place.

19. Set aside a bottle of weak molasses and water for a week or two. Notice that fermentation goes on but that the liquid now tastes sour, for it has become vinegar.

20. Soak a yeast cake in water for a few hours and examine a tiny drop under the microscope with a power of at least 200 diameters. Notice the small oval cells, from the edges of which tiny cells seem to be budding. These are yeast cells. In the same specimen starch grains will appear as much larger irregular bodies of a shape depending upon the kind of grain used in making the yeast.

21. Procure some alcohol. Notice its sharp odor and taste. Show that it will dissolve and remove grease from the hands. Explain that in the arts, it is used to dissolve oils, resins, and such substances as water will not dissolve. Procure some wood spirits and contrast its odor and taste with that of common alcohol. Show that it, too, dissolves grease.

22. Pour some alcohol upon the white of an egg. Notice that the alcohol coagulates it and turns it white.

23. Place a small piece of tender meat in a bottle of alcohol for a day or two. Notice that it turns whitish in color and becomes shriveled, hard, and dry. Explain that the alcohol takes away the coloring matter of the meat, and also coagulates the albumin much in the same way as hemlock bark tans leather. Explain how alcohol preserves substances in this way.

24. Dip a small piece of paper in alcohol and touch it with a match. It bursts into a flame at once, and develops great heat but no smoke. Notice that the paper does not burn until the alcohol is nearly used up. Explain that in the body alcohol seems to be easily oxidized, and uses oxygen which should go to the proper food of the body.

25. Hold a cold stone in the mouth of a teakettle or in the steam of a pan of water. Notice that the vapor condenses in drops upon the stone. This will illustrate distillation as well as a complicated apparatus of coils and running water. Explain that dew upon the grass is a distillation of water.

REVIEW TOPICS

1. Describe how alcohol and vinegar are commonly formed.
2. Describe the *yeast plant*.
3. Describe *mother of vinegar*.
4. Describe *fermentation*.
5. Tell how fermentation is applied to bread making.
6. Describe *malt liquors*.
7. Describe *wine*.
8. Describe *spirits* and the process by which they are made.
9. Describe *alcohol*.
10. Give the three main properties and effects of alcohol.
11. Tell what becomes of alcohol when taken into the body.
12. Tell why alcohol does not satisfy thirst.

CHAPTER V

DIGESTION OF FOOD IN THE MOUTH

64. Food and digestion. — Albumin, fat, and sugar are continually being oxidized in the body, and the products of oxidation, together with mineral matter and water, are being thrown off. In order to keep up the strength and form of the body a constant stream of new material must be supplied.

Anything which, taken inside of the body, supplies it with weight, heat, or energy is food (see pp. 64 and 89).

In preparation for the use of the body, food is reduced to a form which can be dissolved in water, and drawn through the walls of the blood tubes. The blood distributes it to all parts of the body. The process of producing a *chemical* change in food so that it can be taken up by the blood is *digestion*.

Man uses as food a combination of albumin, fat, sugar or starch, mineral matters, and water, which are identical with the proximate principles of the body. Of these water and mineral matters can enter the blood without being changed, while the albumin, fat, sugar, and starch require digestion. Albumin is changed to a form called *peptone*, which can easily diffuse through the walls of the blood tubes, and so become a part of the blood.

Sugar and starch are both changed to *glucose*, a form of sugar found in the grape. Fat is saponified and emulsified.

65. Cooking. — Digestion is begun by applying heat to food, either with or without water. Preparing food by heat is *cooking*. The heat of cooking coagulates the albumin. It also softens and dissolves the connective

tissue which binds together the cells of the food material, and thus makes meat and vegetables tender. It develops an agreeable flavor which stimulates the desire for food and promotes digestion. Cooking has no effect upon fat itself, but the tiny pockets of albumin in which it is stored in meat and vegetables are softened or dissolved away, and the fat is set free. In vegetables and flour, starch is in tiny grains, each of which seems to be made up of layers of starch separated by thin layers of a waterproof substance. Hot water causes the starch to swell and burst these envelopes, and the starch itself is then dissolved, thickening the water to a jellylike mass. Cooking has no effect upon the sugar and mineral matters of the food, except to mingle them thoroughly with the food.

Thorough cooking also destroys many poisons, and all the disease germs in tainted food. Yet cooking does not render tainted food fit for use.

66. Ways of cooking.— Some foods are best cooked by being boiled or stewed. Other foods are best when roasted or broiled. The exact method is not so important as the skill of the one who does the cooking.

In all forms of cooking the principles are the same. If the solid food alone is to be eaten, as much of the juices as possible should be retained in the food by coagulating the albumin upon the outside at once so as to imprison the juices. This can be done by having the water boil before the food is placed in the kettle, or by placing the food in a hot oven. The film which forms upon the outside of the food effectually seals the juices within. If both the solid food and the liquid in which it is cooked are to be eaten, the flavors are better developed if the juices are diffused through the liquid. In this case the food should be placed in cold water or a cool oven, and heat applied gradually so as to avoid coagulating the exterior sooner than the interior. In most cases the food will be of better quality and taste if the cooking is done slowly. When the heat is continued after the food is thoroughly softened, its fibers are apt to become hard and dry.

As a general rule it is best to cook each kind of food separately. Each substance can then be cooked in its own peculiar manner. In roasting and broiling, the fat drips away. The outside of the meat, subjected to a high degree of heat, becomes hard, imprisoning the juices within. The inner part of the meat is protected from the heat and is cooked at a lower temperature than the outside. So its juices remain in a more natural state.

When food made from vegetables or grain is baked, a crust forms upon the outside. This consists of hardened albumin mixed with starch, which is partly changed by the heat to a kind of sugar. If the crust is not too much cooked and dried it is palatable and easily digested.

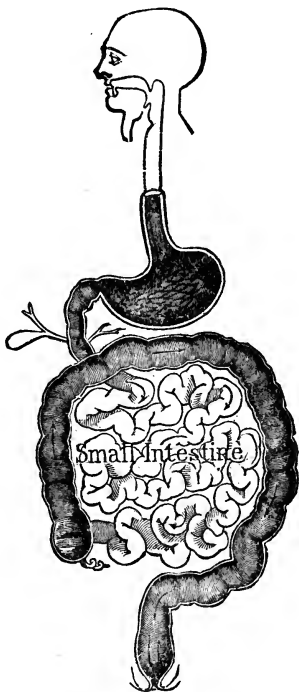

The alimentary canal.

67. The alimentary canal.— Food is taken into the body and digested by means of a tube leading through the body. Beginning at the upper end, the parts of this tube, which is called the *alimentary canal*, are the mouth, pharynx, esophagus, stomach, and intestine.

68. The mouth.— The food is held in the mouth for a few seconds while it is mixed with the watery fluid called the *saliva*, and ground fine by the teeth. This grinding is *mastication*, and the mixture with saliva is *insalivation*. In these two processes, the teeth, tongue, cheeks, lips, and salivary organs all take part. The roof of the mouth is formed by the *bony palate* in front, and the *soft* movable palate behind. It is bounded on the sides and in front by the teeth, cheeks, and lips.

The floor is formed by the tongue and the lower jaw.

69. The jaws. — The lower jaw is a semicircular bone, whose hinder extremities are curved upwards. Each tip forms a hinge which turns in a socket just in front of the ear. It carries a semicircle of *teeth*, which exactly fit against a similar semicircle upon the upper jaw. The lower jaw is moved by powerful muscles in three directions: first, up and down; second, sidewise; third, backward and forward.

The upper jaw is a strong bone of irregular shape, firmly fixed to the rest of the skull. Its interior is hollowed out to form a cavity called the *antrum*, which has a small opening into the nose. The upper ends of the teeth sometimes project so far upward as to make slight elevations upon its floor. Sometimes an inflammation or abscess of

a tooth may extend to the antrum, so that it becomes filled with pus, producing a very serious trouble.

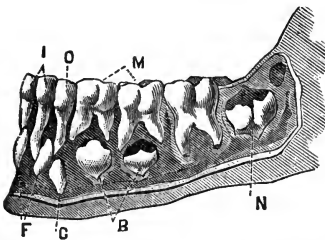

The teeth at the age of six and one half years. *I*, the incisors; *O*, the canine; *M*, the molars; the last molar is the first of the permanent teeth; *F*, sacs of the permanent incisors; *C*, of the canine; *B*, of the bicuspid; *N*, of the second molar; the sac of the third molar is empty. — MARSHALL.

70. Teeth. — The teeth are hard, bony pegs set deeply into the lower jawbone and in the edge of the hard palate.

There are sixteen on each jaw. Counting from the middle of the front of each jaw, the first two on each side are like chisels, so as to bite or gnaw off the food, and are called the *incisors*. In a squirrel, they

are long and sharp, so as to gnaw through wood. The third tooth is the *canine*. It is a round, firmly set tooth,

which in animals is the *tusk*. The next two are larger, with flat surfaces; they are called *bicuspid*s. The next three, the *grinders*, or molars, have large, flat surfaces, well adapted to grinding the food.

In a young child the two bicuspid teeth resemble the molar teeth in the adult, and the three molars are absent. At about the age of six, a whole new set of teeth begins to grow beneath the first teeth, and to press against their roots, cutting off their food supply. The blood takes away the substance of the old teeth as the new ones advance against them, until their projecting parts alone are left attached only by the gum. They finally drop out, while the new ones advance to take their places. The first teeth, like the permanent set, may decay and cause toothache, and should have as good care in filling and cleaning as is given to permanent teeth.

Sometimes when a baby's gums are being cut through by the growing first teeth, they are tender and swollen, making the child fretful. Yet teething seldom causes sickness in a healthy child.

71. Composition of teeth. — The teeth are composed of a very hard kind of bone called *dentine*, which in some large animals is called *ivory*. It is nourished by blood tubes and nerves, which enter at the tip within the jaw and form a pulplike mass in a small cavity in the center of each tooth. The root of the tooth is set into a socket in the jawbone, and a kind of soft bone, called the *cement*, fixes it in place. The projecting part of each tooth, called the *crow*n, is covered with a hard shell called the *enamel*.

72. Care of teeth. — When the enamel is too thin, or is worn or broken off, the dentine beneath it may decay. Then the tooth rapidly goes to pieces, often with much pain. Picking the teeth with pins and cracking nuts often break the enamel. Dirt and particles of food between the teeth are great promoters of decay. The saliva deposits a

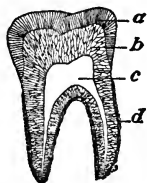

Section of a tooth.

a enamel.

b dentine.

c pulp cavity containing blood tubes and nerves.

d cement.

brown substance called *tartar*, which may press the gum back from the root of the tooth, until a part of the tooth below the enamel is reached. Then the tooth may decay and break off at the gum, or the gum and bone may be forced back from the crown until the tooth becomes loose and drops out. Thoroughly brushing the teeth twice a day with a tooth brush and water is necessary for preserving the teeth. Particles

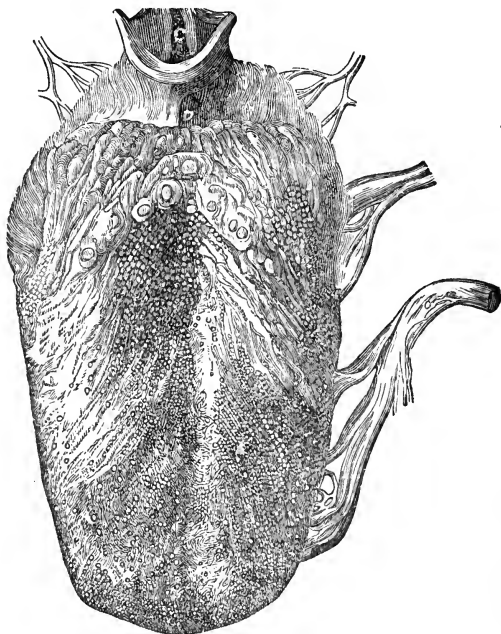

The tongue.

of food between the teeth should be removed, either by a soft wooden toothpick or else by passing a strong thread between the teeth. Still, with the best of care, some decayed cavities may develop, and these should be filled at once. With this care, almost any set of teeth should last a lifetime.

The *cheeks* and *lips* are thin layers of skin and muscles, which can be moved freely in all directions.

The *tongue* is a long, flat muscle, attached at its back end only, while its front part is capable of varied and precise movements in every direction.

73. Mucous membrane.—The cavity of the mouth is everywhere lined with a thin membrane, directly continuous with the outside skin. It consists of a loose network of cells carrying blood tubes and nerves. It is covered with a layer of flat cells, called *epithelium*. Into the loose tissue beneath the epithelium, there project pockets or tubes lined with cells directly continuous with the epithelial cells of the surface of the mouth.

In health, the cells of each of the tubes and of the surface of the mouth produce just enough of a thin, clear liquid, called *mucus*, to moisten and lubricate the surface of the mouth. This membrane is called a *mucous*

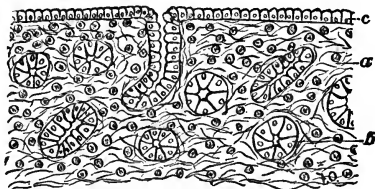

Mucous membrane ($\times 200$).

- a cells and loosely woven fibers forming the main part of the membrane.
- b mucous glands cut across.
- c epithelium upon the surface.

membrane. It is continued into the stomach and intestine, and into the windpipe and lungs.

Mucous membrane is modified skin turned in from the surface of the body to line the interior of all the cavities which communicate directly with the air. Every such surface is covered by an unbroken layer of epithelial cells. Wherever the epithelial cells are absent, the spot is raw and sore. The epithelial cells of the surface of the mucous membrane are designed mainly for protection; but those which reach into the tubes are set apart for the special work of producing mucus from material supplied by the blood.

74. Gland and secretion.—A collection of pockets or tubes lined with epithelium which forms a substance out

of the blood is a *gland*. The substance formed is called a *secretion*. The epithelium of the gland does all the work of secreting. All the mucous membranes of the body contain glands which secrete



a mucus, and in addition many contain glands which secrete other substances.



b 75. Sore mouth. —

Babies sometimes suffer with a form of sore mouth in which white specks, like curdled milk, appear upon its mucous membrane.

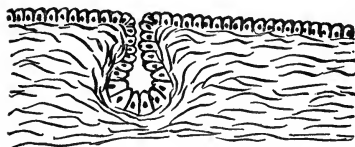

The spots are due to a kind of mold which grows in milk. Gently washing the mouth with clean, warm water several times a day will destroy the mold and remove the sores.

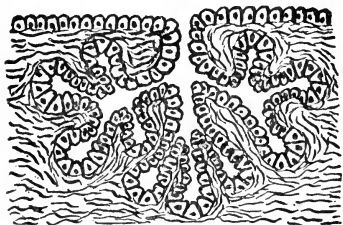

d

Diagram of glands.

a epithelium upon the surface of a mucous membrane.

b the epithelium continued into a simple tube.

c the epithelium continued into a simple pocket.

d the epithelium continued into a series of branching tubes and pockets.

b, *c*, and *d* are glands.

76. Salivary glands. —

The mouth contains a fluid, called *saliva*, which enters it from three tubes on each side. Each salivary tube, after it has extended into the flesh on the face for an inch or so, abruptly divides again and again like the branches and twigs of a tree. At the end of the smallest divisions, there are minute pouches $\frac{1}{500}$ of an inch in

diameter. All these tubes and pouches are rolled into a small mass with blood tubes and nerves. The whole collection is called a *salivary gland*. Each tube and pouch is lined with epithelial cells which make the saliva out of the fluid parts of the blood in which they are always bathed. The saliva flows out of the tubes into

the mouth as fast as it is secreted. There is a salivary gland in front of each ear, called the *parotid gland*; one along each side of the lower jaw, called the *submaxillary gland*, and one just under each side of the front end of the tongue, called the *sublingual gland*.

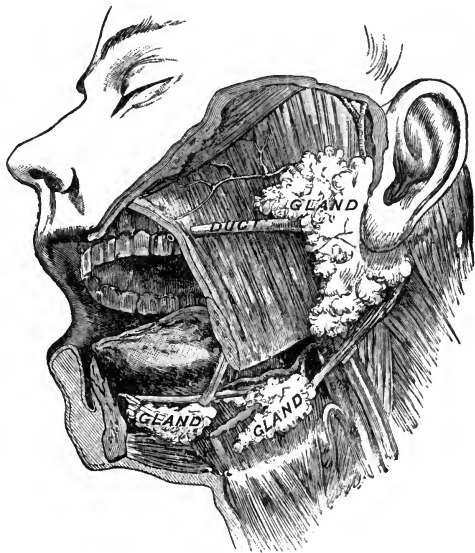

The salivary glands.

77. Saliva. —

The saliva is a thin, colorless, alkaline mixture, which often contains air bubbles. About $\frac{1}{1000}$ part of the saliva is a white substance called *ptyalin*, which has the power to change starch to glucose while remaining unchanged itself. Hence, ptyalin is a *ferment*. It can act only in an alkaline fluid, and its action stops when the food is acted on by the stomach. It digests only a small amount of starch, and its value is due mainly to the water it contains.

78. Use of the water in saliva. — The water of the saliva has very important uses. The nerves of taste are covered by the epithelium of the mucous membrane, and some of the food must be carried through this epithelium to the nerves in order that it may be tasted. The water of the saliva dissolves the food and soaks through the epithelium, carrying a tiny amount of food to the nerves, and thus makes the sense of taste possible.

During digestion, food must be reduced to a fluid condition as thin as milk. The saliva begins the process. Enough saliva is mixed with food to form a pasty mass which the thin walled stomach can handle with ease.

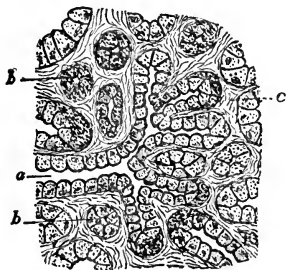

A salivary gland ($\times 200$).

a tube of epithelium forming the gland, cut lengthwise.

b tubes cut crosswise.

c connective tissue binding the tubes in place.

79. Production of saliva. — Saliva enters the mouth continually, but between meals only about an ounce an hour is produced, while during a meal the food increases in weight about one half by the addition of saliva. From one to three pints are produced daily. The flow of saliva is excited by the act of chewing, and by anything held in

the mouth, especially if it be of an agreeable taste and odor. Hunger, or the sight or thought of agreeable food, "makes the mouth water." The longer food is chewed the more saliva is produced. This mixing and dissolving action of the saliva is greatly aided by the movements of the various parts of the mouth.

80. Mastication. — A morsel of food is pushed between the molar teeth, which crush and grind it by the three movements of the lower jaw. Between each movement of the jaw, the tongue and cheeks roll the morsel into a firm mass so that the teeth can act upon it to better advantage. The tongue has a delicate sensibility for the proper condition and position of the food, and its varied and precise move-

ments, aided by the movements of the lips and cheeks, keep the food in the best position for the action of the teeth. In a few seconds, even hard and dry food becomes a thin and pasty mass. The tongue collects the mass into a ball in the back part of the mouth in preparation for its passage to the stomach. The process of sending food from the mouth to the stomach is *swallowing* or *deglutition*.

81. The pharynx. — Back of the tongue is a muscular bag about four and a half inches in length, lying against the spinal column and called the *pharynx*. It is lined with mucous membrane, which secretes far more mucus than that of the mouth. When the secretion of mucus is excessive it is called *catarrh*, but it is usually a harmless affection. The pharynx has seven openings; one into the esophagus or muscular tube leading to the stomach; one into the beginning of the

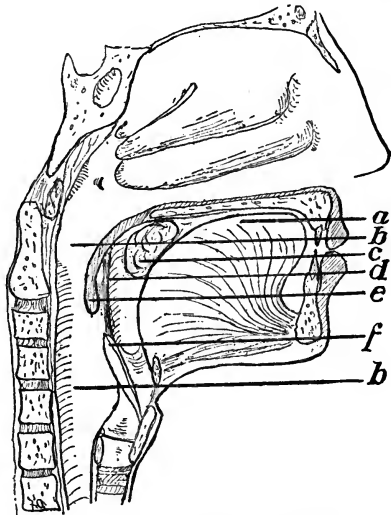

Diagram of the beginning of swallowing.

- a top of tongue.
- b pharynx.
- c morsel of food.
- d sliding door of the front of the pharynx.
- e soft palate.
- f epiglottis.

windpipe; one into the mouth; two into the nose, and two into the middle ear. The openings to the nose and ears can be closed by raising the soft palate against the spinal column. The windpipe can be closed in three ways: first, by the root of the tongue arching itself backward over the windpipe; second, by a cover to the windpipe, called the *epiglottis*; third, by the *vocal cords* sliding

together in the middle. The opening to the mouth can be closed by two upright muscles which hang between the back part of the soft palate and the base of the tongue.

These two muscles come together in the middle like sliding doors.

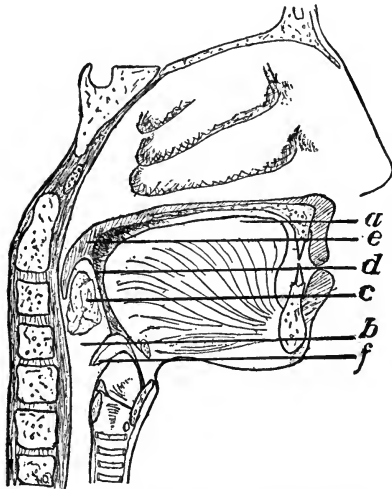

Diagram of second part of swallowing.

- a* top of tongue arched backward and upward.
- b* pharynx.
- c* morsel of food pushed into the pharynx by the back of the tongue.
- d* sliding doors of the pharynx which have come together in the middle.
- e* soft palate lifted upward to shut off the nose.
- f* epiglottis folded downward to close the larynx.

82. Swallowing. — By a conscious effort, the tongue quickly pushes the morsel of food backward towards the pharynx. The two upright muscles of the pharynx, gliding together over the surface of the tongue between it and the food, cut the food off from the mouth. During this movement the pharynx closes all its other openings, except the one to the esophagus. The food is now beyond the control of the will. The muscles of the pharynx itself now contract, forcing the food into the esophagus, the opening

of which is the only one not closed.

83. The esophagus. — The esophagus is a muscular tube connecting the pharynx with the stomach. It is about nine inches in length. It is lined with mucous membrane and secretes only enough mucus to moisten its surface. When food reaches it, a ring of the muscular

tube contracts just above the morsel. This contraction runs down to the stomach, forcing the food before it as though a tight iron ring were slipped down over the esophagus. A contraction of a tube within the body in a regular manner, producing an onward movement of its contents, is called *peristalsis*. While a horse is drinking, the peristalsis of the esophagus may be plainly seen along its neck.

SUMMARY

1. Anything which taken inside the body supplies it with weight or heat or energy is food.
2. All foods are composed of one or more of the five substances: water, albumin, fat, starch or sugar, and mineral matter.
3. Food must become liquid in form and enter the blood tubes before it can reach the cells of the body.
4. Cooking softens the food and develops its flavors. It also destroys many poisons in food.
5. In the mouth food is ground fine between the teeth and mixed with the saliva so as to form a thin paste.
6. Saliva contains a ferment which changes some of the starch of the food to sugar.
7. The tongue pushes the chewed food backward into the pharynx. The pharynx then closes all its openings except the one into the esophagus. The pharynx then squeezes the food into the esophagus, and the esophagus forces it into the stomach.
8. All cavities of the body which have an opening leading to the air are lined with a kind of soft skin called *mucous membrane*.
9. Mucous membrane is a network of cells and fibers covered with flat cells called *epithelium*.

10. Mucous membranes contain little pockets of epithelial cells, which produce a slippery fluid called *mucus*.
11. A collection of pockets or tubes, lined with epithelium, which separates a substance from the blood, is a *gland*.
12. The saliva is formed in three glands upon each side of the face.

DEMONSTRATIONS

26. Notice the various movements of the teeth and tongue, lips and cheeks, in chewing. Have one of the pupils open his mouth wide. Show how the soft palate which forms the roof of the mouth can be raised and lowered. Show the sliding doors of the pharynx, which reach up to the soft palate and with it form an arch over the back part of the tongue. Notice the small projection which points downwards from the summit of the arch. This is called the *uvula*.

27. Have the pupils swallow slowly. Notice that the tongue, beginning at the tip, is applied to the roof of the mouth until its whole length touches the palate. Notice that when the back part of the throat begins to swallow, the food is beyond the control of the will. Notice that breathing is stopped, for both the nose and windpipe are closed.

28. Get a tooth and have it sawed in two lengthwise, so as to show the cavity in its interior. Get another, partly decayed, to show how the nerves of the interior are laid bare and exposed to injury.

29. Procure the lower jaw of a sheep or pig. With a hammer and chisel split open a part of the bone to show how the teeth are set into the bone.

30. Point out the difference between the skin and the mucous membrane of the lips. Notice that the two are directly continuous. Explain that the mucous membrane is really a modified skin, and that anything in the mouth and stomach is really outside the body proper just as it would be if it were held in the closed hand.

31. Examine a specimen of mucous membrane under the microscope, using a power of at least 200 diameters. Notice the layer of epithelial scales covering its outside. Notice the network of fine connective tissue which makes up the main part of the membrane. Notice the glands. They are tubes, but are cut across in the specimen

and appear as circles lined with large cells. Explain that the cells of the glands produce the mucus.

32. Have a boy open his mouth and raise his tongue upward and backward. With a handkerchief wipe dry the space between the tongue and teeth. In a moment a drop of water will collect between the small projections near the tongue. Move the tongue slightly, and notice that the liquid flows in a tiny stream. Explain that this is the saliva flowing from the sublingual gland.

33. Chew a piece of white bread. After a little, notice that it has a sweetish taste. Explain that the sweetness is due to the action of the ptyalin of the saliva in changing the starch to sugar.

34. While a horse or a cow is drinking, notice the peristalsis of the esophagus along its neck as it swallows each mouthful.

REVIEW TOPICS

1. Define *food* and name the five classes.
2. Tell what change each must undergo in order to enter the body.
3. Tell what effect *cooking* has upon each class of food.
4. Discuss the different ways of cooking.
5. Give the parts of the alimentary canal.
6. Describe the *mouth*.
7. Describe the *jaws* and *teeth*.
8. Tell how the teeth are commonly injured, and how to preserve them.
9. Describe the *cheeks*, *lips*, and *tongue*.
10. Describe a *mucous membrane*.
11. Define a *gland*.
12. Describe a *salivary gland*.
13. Describe the use and appearance of *saliva*.
14. Describe *mastication*.
15. Describe the *pharynx*.
16. Describe *swallowing*.
17. Describe *peristalsis*.

CHAPTER VI

STOMACH DIGESTION

84. Cavities of the body. — A muscular partition, curved sharply upward, divides the inside of the body into two cavities, — an upper one,

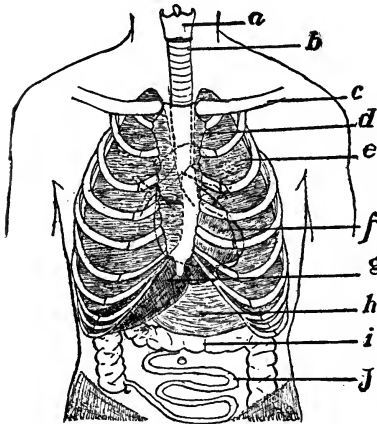

Organs of the chest and abdomen.

- a* larynx.
- b* trachea.
- c* clavicle, or collar bone.
- d* sternum, or breastbone.
- e* lung.
- f* heart.
- g* liver.
- h* stomach.
- i* large intestine.
- j* small intestine.

called the *chest* or *thorax*, which contains the *heart*, *lungs*, and the *esophagus*, and a lower one, called the *abdomen*, which contains the *stomach*, *intestine*, *liver*, *spleen*, and *kidneys*. This muscular partition is called the *diaphragm*.

85. The abdomen and peritoneum. — The abdomen is a closed cavity, bounded above by the diaphragm, on the sides partly by the ribs, and behind partly by the spinal column. The bones of the pelvis form its floor. The rest of its walls are formed by thick sheets of muscles. It is lined with a very smooth membrane called the *peritoneum*.

The peritoneum also covers the outside of all the abdominal organs. Such a membrane, lining a cavity which is not in open communication with the air, is a *serous* membrane. The peritoneum is the largest and most important serous membrane. It is a thin, closely-woven network of interlacing cells covered by a single layer of flat cells, which give it a shiny appearance. It is moistened by a small quantity of watery fluid, which is not produced by glands, but is a part of the lymphatic circulation. Its smoothness permits easy movements among the organs of the abdomen.

86. The stomach.—The stomach is the first organ into which the food passes when it leaves the esophagus. It lies mostly on the left side of the abdomen half covered by the lower ribs. It is a conical enlargement of the alimentary canal, and is situated between the esophagus and the small intestine. It is about twelve inches in length and five inches

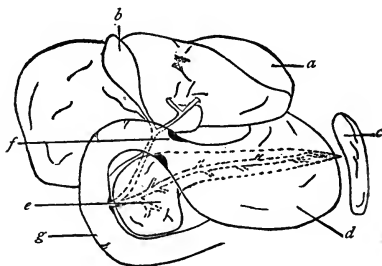

Organs in the upper part of the abdomen.

- a* liver, raised up.
- b* gall bladder upon the under surface of the liver.
- c* spleen.
- d* stomach.
- e* pancreas; the line passes through the common opening of its tube and that from the gall bladder.
- f* pylorus.
- g* duodenum.

in diameter. It is composed of a layer of muscle covered with peritoneum and lined with mucous membrane. Its walls are from $\frac{1}{16}$ to $\frac{1}{8}$ inch in thickness. It is hung in place by a short curtain of peritoneum, which is attached above to the under-surface of the liver and diaphragm. The esophagus opens into the stomach at its upper left side, called the *cardiac* extremity. The opening into the intestine is at the right and narrowest part, and is called the *pylorus*. The pylorus can be closed by a thick ring of muscle.

87. Glands of the stomach. — The mucous membrane of the stomach contains numerous glands which secrete a special digestive fluid called the *gastric juice*. The glands are short tubes each about $\frac{1}{250}$ of an inch in diameter, and $\frac{1}{40}$ of an inch in length. The tubes are set closely together and resemble pinpricks in the mucous membrane.

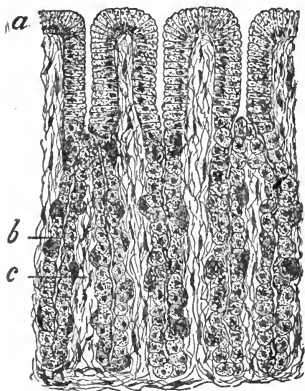

Gastric glands in the stomach
($\times 200$).

- a* epithelium of the surface of the stomach.
b epithelium lining the tubes of the glands.
c connective tissue between the tubes.

Each tube is lined with a single layer of epithelial cells which produce the gastric juice from material supplied by the blood. Besides these glands there are many others which secrete only mucus.

88. Gastric juice. — The gastric juice is a yellowish fluid, and consists of water holding in solution *hydrochloric* acid and two ferments. These are the essential agents in stomach digestion. Hydrochloric acid is produced by the epithelium of the gastric tubes from the salt contained in the blood, and forms from $\frac{1}{5000}$ to $\frac{1}{500}$ of the gastric juice. The ferments are white, albuminous substances produced from the blood by the epithelium of the glands, and form about $\frac{1}{500}$ of the gastric juice. The flow of gastric juice is promoted by a slow, steady in-taking of food at about the temperature of the body. The saliva, which is slightly alkaline, an agreeable taste of the food, and a pleasant frame of mind also aid its flow. About three quarts enter the stomach each day.

89. Peristalsis of the stomach. — Anything taken into the stomach causes a continuous and regular movement of the organ, due to the alternate contraction and relaxation of its muscular fibers. This is an example of slow peristalsis. The food is thus caused to flow in a steady stream from the esophagus to the left, and then down to the right and back again, completing the circuit of the stomach in about three minutes. By this movement it is thoroughly mixed with the gastric juice.

90. Ferments of the gastric juice. — One of the ferments of the gastric juice, *rennin*, acts by coagulating milk. In the child this action is very important.

The other ferment, *pepsin*, softens the albumin of food and changes its character so that it will dissolve in water and diffuse through the walls of the blood tubes to become a part of the blood. This form of albumin is called *peptone*.

A quarter of a grain of pepsin can render a whole white of an egg soluble. It acts best at the temperature of the body, and there must be an acid present. The surface of the food particles are acted upon first, and the products of its action are rubbed off by the peristalsis of the stomach, and the next layer is acted upon in the same manner. Some of the gastric juice penetrates between the particles of food, and slowly eats its way into the food mass, thus dissolving apart the separate cells which compose the food. Its action is confined solely to the albumin. In fat meat the albuminous pockets are eaten away, and the fat is set free. Starch is not acted upon, except to be freed from its albuminous envelopes.

The result of stomach digestion is a fluid called *chyme*. Peptone imparts to it a bitter taste, while small particles of fat give it a milky appearance. Food then appears as it would if it had been boiled for a long time.

91. Use of the acid. — Pepsin can act only in the presence of the acid, in an amount at least sufficient to neutralize the alkali always

present in the food. The gastric juice is more often deficient in acid than in pepsin.

Besides assisting the pepsin the acid alone can perform the first stages of changing albumin to peptone. Living germs of fermentation and disease are sometimes swallowed. The acid destroys them if it is present in the gastric juice in its full amount. This is a provision of nature to prevent fermentation from taking place in the stomach, which might otherwise become sour at every meal. This explains why diseases are more easily caught when the stomach is deranged. In a healthy person the germs meet the destroying acid almost at the entrance to the body.

92. Amount of stomach digestion. — The stomach digests only albumin. The main uses of the stomach are, to act as a storehouse for food, to mix it with the watery gastric juice, and to reduce it to a form still more liquid than when it left the mouth. The acid prevents the food from spoiling, and, with the pepsin, begins the digestion of the albumin. The stomach is not absolutely necessary for digestion, but because of its capacity it enables us to carry a store of food so that we do not need to eat every few minutes.

93. Passage of food into the intestine. — Every minute or two the pylorus opens, permitting a little of the chyme to escape into the intestine, where the main work of digestion is performed.

Some food begins to pass out of the stomach within a few moments after eating. The time required for the stomach to empty itself completely is from two to five hours, depending upon the amount of food and the ease with which it is broken up. Thus we commonly say that it takes from two to five hours for food to digest.

When the stomach has been empty for some time, there is a sense of hunger. Yet the intestine may still contain enough undigested food to supply the body for hours.

SUMMARY

1. The diaphragm divides the inside of the body into an upper cavity called the *thorax* and a lower one called, the *abdomen*.
2. In the abdomen are the organs of digestion.
3. The lining of the abdomen and the covering of its organs is a smooth membrane called *peritoneum*.
4. The stomach is a muscular bag lined with mucous membrane and covered with peritoneum. In its mucous membrane are glands which produce the *gastric juice*.
5. The gastric juice is water containing *hydrochloric acid*, and two *ferments*. It changes albumin to peptone.
6. The actions of the stomach may be summed up in three things: (1) It is a storehouse in which food is held while being passed on to the intestine in a slow and steady stream. (2) Its peristaltic movements break up the food and mix it with the gastric juice. (3) It digests some albumin by means of the acid and pepsin of the gastric juice.
7. Every minute or two some of the liquefied food passes through the pylorus into the intestine.
8. In from two to five hours after a full meal the stomach is usually empty.
9. The stomach has no action upon starch or fat, and digests only a part of the albumin.

DEMONSTRATIONS

35. Show the internal organs of an animal. A frog or a mouse will do; but a rat, a rabbit, or a cat will be better.

Always prepare the specimen in private, and leave it before the class only while it is actually being shown. Cover all the parts except those to be shown, and wash away all traces of blood. Any small animal may

be killed quickly and painlessly by placing it in a tight box or covered pail and pouring in half an ounce of chloroform. Demonstrations of the internal organs had better be made only before those members of classes who wish to see them.

36. It is well to preserve permanent specimens of the different organs. One part of formalin to 30 parts of water is most excellent. It is neither expensive nor poisonous, while it preserves specimens in their natural form and color. The following inexpensive mixture, known as *Müller's fluid*, is also good.

Sodium sulphate (Glauber's salt),	1 part,
Potassium bichromate,	2 parts,
Water,	100 parts.

This forms a yellow fluid and stains the specimens yellow. It is only slightly poisonous, even if taken into the mouth, while soap and water will remove it from the hands.

Put the specimen in a large covered earthen or glass jar, with an amount of the fluid equal to at least five times the bulk of the specimen. Remove it from the jar to a platter when showing it to the class. The fluid will harden the tissues so that even soft organs may be handled with safety.

Special training is required in preparing microscopic specimens showing the tissues in their proper position. The difficulty consists in cutting a slice thin enough; for the microscope magnifies in thickness as well as in length and breadth.

37. Open the abdomen of a dead animal by a cut from the ribs to the end of the body. Notice that the organs and walls of the abdomen are shiny from their covering of peritoneum. Notice that the peritoneum is thin and strong, that its appearance differs from that of a mucous membrane, and that it can be peeled from the abdominal walls. (See demonstration 35.)

38. Notice the shape and position of the stomach. Open it to show the folds in the mucous membrane. With a specimen of mucous membrane under the microscope show the short, straight gastric glands standing side by side. Sketch them. (See demonstration 35.)

39. Notice the dome of muscle extending completely across the body above the stomach. Explain that this is the diaphragm, and that it divides the body into two cavities. Open the chest and show its cavity and the top of the diaphragm, which separates it from the abdominal cavity. (See demonstration 35.)

40. Illustrate stomach action by placing small slices of hard-boiled egg in—

Hydrochloric acid,	40 drops,
Pepsin,	1 grain,
Water,	$\frac{1}{2}$ pint.

Keep the mixture in a warm place, shaking it occasionally. In a few days the egg will completely dissolve. Show some powdered pepsin and some dilute hydrochloric acid.

41. Boil some potatoes and meat for several hours, to illustrate the appearance of chyme as it leaves the stomach.

REVIEW TOPICS

1. Describe the two main cavities of the body.
2. Describe the *lining of the abdomen*.
3. Describe a *serous* membrane.
4. Describe the *stomach*.
5. Describe the *gastric juice* and the *glands* in which it is formed.
6. Tell the name and the action of the *acid* of the gastric juice.
7. Tell the names and the actions of the two *ferments*.
8. Tell how each *class of food* is affected by the stomach, and how much.
9. Describe the *peristaltic* movements of the stomach.
10. Tell how the food passes from the stomach into the intestine.
11. Tell how important the work of the stomach is in comparison with the work done in the intestine.

CHAPTER VII

ABNORMAL ACTION OF THE STOMACH

94. The appetite. — Eating is designed to furnish the body with proper nourishment, but many “live to eat,” and pay for their meals with a host of bad feelings. The amount and kind of food, and the time of eating, must be suited to the needs of the body. A wild animal eats and thrives without thought of what it eats, for nature has given it certain signs which it follows blindly and yet securely. Man possesses the same signs, and if they were followed, indigestion would be rare. The sign of the need of food is the feeling of hunger and thirst, or the *appetite*. The kind of food required is indicated by the sense of *taste*, and the proper amount of food is known by the absence of hunger and by the sense of taste beginning to fail.

95. Natural taste of food. — The simplest kind of food tastes the best to a hungry person. He eats it with keen enjoyment until his hunger is satisfied. If he leaves the table now and goes about his work, his meal will digest without producing unpleasant feelings.

Food flavored only with salt has a natural taste of which we never tire, and which gives reliable signs as to the quantity needed, and the time of eating. If only this kind of food is placed upon the table, the sense of taste and the satisfied feeling at the end of the meal are reliable guides as to the amount and kind of food needed.

96. Perverted appetite. — After hunger has been satisfied with all the food needed, a food with an artificial taste is often brought on, and a new appetite arises. The taste soon learns to prefer the artificially prepared food, and the education of "living to eat" is begun. Pie, cake, sweets of all kinds, spices, and seasonings are eaten mainly to please an acquired appetite.

Sweets and highly seasoned food do not satisfy a hungry man as plain food does, but on the contrary their taste becomes sickening to the stomach, before they begin to satisfy his hunger. Moreover, the appetite for artificial things may persist after the stomach is filled.

97. Intemperate eating. — In the hurry of business or pleasure men gulp down their dinners in huge mouthfuls, and overload their stomachs before the surprised organs can take account of the kind or quantity of food eaten. Some eat too much in prolonging the pleasures of taste. Nearly everybody indulges an appetite for sweets and highly seasoned food. Satisfying an appetite which is not the expression of actual need of the body is as much *intemperance* as drinking strong drink, and leads to the same kind of serious results.

98. Insufficient mastication. — A whole train of evils follows intemperate eating. When food is swallowed in large lumps instead of being masticated to a thin gruel, too little saliva is mixed with it. It reaches the stomach too dry, and so a larger amount of gastric juice is needed. But the saliva is the natural stimulant to the flow of juice, and if it is small in amount, the gastric juice does not flow in sufficient quantity and food is not well digested.

99. Too much food. — An excessive amount of food stretches and weakens the stomach, and peristalsis cannot take place so vigorously as it should. The lumps of food are neither penetrated by the gastric juice nor ground to pieces by the peristalsis, but only their outer surfaces are slowly dissolved. The food thus remains too long a time in the stomach, and some may stay there until the next meal.

100. Eating between meals. — Eating at irregular hours or between meals also disturbs the stomach. Two or three hours after a meal the work of the stomach should be done, and it should be permitted to rest. If more food of any kind is eaten, the stomach must either be overworked or the food not be digested.

Food which the gastric juice softens with difficulty behaves like large lumps of food, and finally either is vomited, or is passed on to the intestine to create more trouble there.

101. Fermentation in the stomach. — The stomach cannot be abused in any way without suffering in all its actions. It gives expression to its suffering by pain, headache, heart beating, and a host of other bad feelings. It makes the whole body weak and sick. Its imperfect action also permits fermentation to go on, which makes the food sour. Living germs like those producing alcohol and vinegar are continually being eaten. In health, the acid of the gastric juice destroys them, but when anything weakens the acid or prevents it from reaching the germs, they grow and produce vinegar and other acids, and also gases. The result is a *sour stomach* and “wind on the stomach,” which comes up and out of the mouth as though it were vomited. This is a sign of indigestion.

The gas distends the stomach and presses it against the heart, so that the beats are felt; and then the heart and not the stomach receives the blame. A sour stomach is at first the result of improper action, not the cause; but, once developed, it may cause a greater disturbance, and then there is only a step to actual stomach disease.

102. Drinking while eating. — A great part of the work of digestion consists in mixing food with water. When dry food is eaten, the gastric juice must be produced in large amount before digestion can begin. A glass or two of water, either alone or with tea or coffee, aids the action of the gastric juice. If the water is not used in place of saliva in moistening the food, or is not employed to hasten the act of swallowing food, drinking during meals will be beneficial. Many drink too little liquid.

103. Hot or cold food. — Food either too hot or too cold hinders the production and action of the gastric juice and disturbs peristalsis, so that the movements of the stomach may not resume their natural course until a long time after the temperature of the food becomes that of the body. A glass of ice water may remain perceptibly cold to the stomach for from one quarter to half an hour, and its effects upon the movements of digestion may last much longer.

104. Rest and eating. — When the body is very tired, the stomach has not the proper energy for digesting food. If food is eaten just as a person comes home fatigued by a hard day's work, there is apt to be a night of pain and indigestion. If, before eating, a glass of warm water or coffee or milk is taken, followed by a short nap, so as to rest the body, the meal will be enjoyed, and digestion will go on unaccompanied by bad feelings.

After a meal the stomach requires an extra amount of blood and energy. A rest of fifteen minutes after each meal would be a great health saver.

105. Rules for eating. — Chew each mouthful to a paste and swallow it before taking another.

Stop as soon as the taste of plain food begins to pall.

Allow four or five hours to elapse before eating again.

SUMMARY

1. Hunger indicates the need of food, and taste indicates the kind.
2. When only plain food is eaten, these two signs are correct guides in eating.
3. An appetite for sweet and highly seasoned food may persist after hunger has been satisfied with plain food.
4. Sweet and seasoned foods soon disgust the sense of taste, thus showing that they are not needed.
5. Eating food for mere pleasure is *intemperance*.
6. Eating too much, too rapidly, or too often is *intemperance*.
7. As a result of intemperate eating, acid fermentation often occurs in the stomach, producing discomfort and sickness.
8. A person should eat only plain food, slowly, and at intervals of not less than four or five hours.

DEMONSTRATION

42. Nearly every one has felt the effects of intemperate eating. When "stomach sick," a sharp-tasting gas and very sour food often come up to the mouth, showing that acid fermentation is going on. Notice how plainly a person feels his own heart beats after a large meal, owing to the pressure of the distended stomach upon the heart.

REVIEW TOPICS

1. Tell how a person knows when and how much to eat or drink.
2. Define an appetite and tell how it can be satisfied naturally.
3. Illustrate an artificial appetite and tell how it can be distinguished from a natural appetite.
4. Tell some of the ways in which men abuse their stomachs by indulging their artificial appetites.
5. Tell some of the effects of too rapid eating; of imperfect mastication; of overeating; of eating between meals.
6. Tell how food sours within the stomach.
7. Tell how drinking at meal times is beneficial, and in what way it can be harmful.
8. Tell how hot or cold food affects the stomach.
9. Give some simple rules for eating.

CHAPTER VIII

INTESTINAL DIGESTION

106. The intestine. — The part of the alimentary canal below the stomach is called the *intestine*. The intestine is a tube of varying size, whose different parts have different names. Next to the stomach is the *small intestine*, which is about one inch in diameter and about twenty feet in length. It opens into the *large intestine*, which is about two inches in diameter and five feet in length.

107. The small intestine. — The small intestine is very movable, and is coiled in the abdomen in no definite order. It is held in place by a fanlike fold of peritoneum, called the *mesentery*. The mesentery is about four inches in length along its back edge, which is fastened to the spinal column, and twenty feet at its outer edge, to which the intestine is attached. Its breadth from the spinal column to the intestine is about four inches.

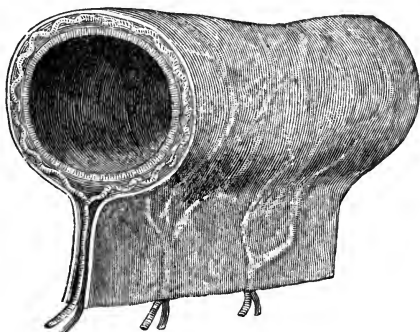
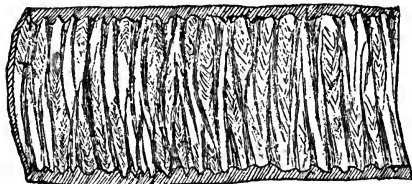

Diagram representing a cross section of the small intestine, showing the three layers, and the way in which the blood tubes pass between the two folds of serous membrane (the peritoneum) which forms the mesentery.

In front of the intestine, and partly enwrapping its folds, is a thin apron of peritoneum, called the *omentum*. It contains much fat, and acts as a cushion and as protection against cold. The small intestine for about ten inches from the stomach is called the *duodenum*. Then for about eight feet it is called the *jejunum*, and the remaining eleven feet is called the *ileum*. There is no very marked difference between any two sections of these divisions.

The intestine ends at about the level of the hip bone, and opens into the side of the large intestine by a slitlike valve, which permits matter to pass into the large intestine, but to a great extent prevents its backward movement.

108. The large intestine, or colon. — The whole large



A piece of intestine showing the folds of the valvulae conniventes upon its inner surface.

intestine is called the *colon*. Its beginning is a small pouch called the *cæcum*, which is situated on the right side of the abdomen at the level of the hip bone.

From the *cæcum* there extends a small tube one quarter of an inch in diameter and two inches long, closed at its outer end. This tube is called the *vermiform appendix*. It sometimes becomes inflamed, forming an abscess, and produces the disease called *appendicitis*.

The colon extends upward to the ribs, then crosses the abdomen to the left side, and then extends downward. These parts are called the *ascending*, *transverse*, and *descending* colon. The colon is held in place by a narrow fold of peritoneum. It is not an even tube, but looks as though strings were tied about it at intervals of a few inches.

109. Structure of the intestine. — The whole intestine consists of a tube of muscular tissue, whose walls are

from $\frac{1}{16}$ to $\frac{1}{8}$ of an inch in thickness. It is covered with peritoneum and lined with mucous membrane. Its muscle fibers extend both lengthwise and circularly. In the mucous membrane of the small intestine are folds, each of which

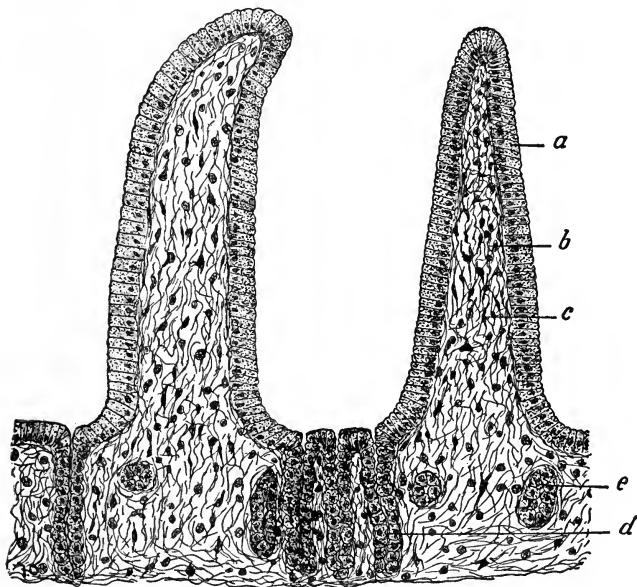

Villi ($\times 200$).

- a* epithelium upon the surface of the villi.
- b* connective tissue fibers which support the blood tubes and lacteals.
- c* connective tissue cells.
- d* glands which form the intestinal juice.
- e* intestinal gland cut across.

extends from one half to three fourths the way around the intestine. The folds are called *valvulae conniventes*. Upon the surface of each fold are fingerlike projections called *villi*, which are from $\frac{1}{50}$ to $\frac{1}{8}$ of an inch in length, and from $\frac{1}{250}$ to $\frac{1}{70}$ of an inch in diameter. Between the bases of the villi minute tubes, $\frac{1}{250}$ of an inch in length and $\frac{1}{600}$

of an inch in diameter, extend into the mucous membrane. Each tube is lined with a layer of epithelial cells, which secrete a fluid called the *intestinal juice*.

110. Villi. — Each villus consists of an outer covering of epithelial cells, inclosing a loose meshwork of fine blood tubes, and also of tubes called *lacteals*, both of which take up the food as it is digested. Neither villi nor *valvulæ conniventes* are found in the large intestine.

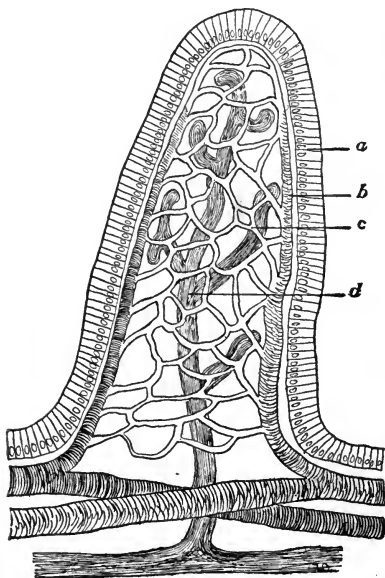

Diagram of the essential parts of a villus.

a epithelium which takes up food and transports it to the tubes within.

b an artery. *c* capillaries. *d* a lacteal.

111. The pancreas. — From the duodenum there extends a very short tube, about the size of a small quill. This divides into two tubes, one of which goes to the liver and the other to the pancreas. The *pancreas* is a gland about an inch in diameter and six inches long, lying behind the stomach. In

lower animals it is called the *sweetbread*. Its structure resembles that of a salivary gland. It secretes a thin, watery liquid called the *pancreatic juice*, which is poured into the intestine at the rate of one and a half pints a day.

112. The liver. — The liver is a firm, dark-red, wedge-shaped organ, lying under the lowest ribs upon the right

side. It is covered with peritoneum and hung closely to the diaphragm and the spinal column.

The tube leading from the intestine to the liver divides again and again into branches called *bile ducts*, the small-

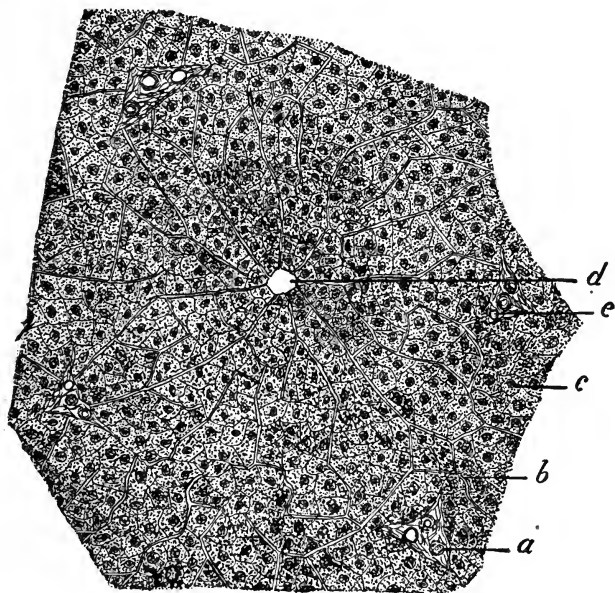

A thin slice of liver ($\times 200$).

- | | |
|---|--|
| <i>a</i> veins bringing blood to the liver. | <i>c</i> liver cells. |
| <i>b</i> capillaries between the liver cells. | <i>d</i> vein to carry blood away from the liver |
| | <i>e</i> tubes to carry away bile. |

est of which are exceedingly minute, and barely recognizable with a microscope. The walls of the smallest of these ducts are composed of large cells of irregular shape, which crowd one another so that the bile tubes are almost closed. These cells make up the greater part of the liver.

Among these tubes there run many fine blood tubes, in such a manner that the cells seem to be arranged around

the capillaries instead of around the bile tubes. Each cell makes bile from the blood and pours it into its bile tube, down which it runs, uniting with streams from other tubes. All the tubes finally unite their streams in the single bile tube which leads to the intestine. A side tube leads from the large bile tube to a bladder on the under side of the liver, called the *gall bladder*, which stores the bile when it is not needed in the intestine.

113. Bile. — Bile is a thick, golden-colored liquid of a very bitter taste. It consists of waste albuminous matter, coloring substances, and mineral matters dissolved in water. Although it is a waste product, it has very important uses in digestion. About a quart is produced daily.

114. Intestinal fluids. — As the food enters the intestine it finds three new substances ready to act upon it. These substances are the *intestinal juice*, the *pancreatic juice*, and the *bile*. All these liquids are *alkaline*, and tend to neutralize the acid in the food as fast as it comes from the stomach.

115. Intestinal juice. — The intestinal juice is small in amount, and contains ferments which change starch to glucose, and albumin to peptone; but its action is slight, and the amount digested by it is small.

116. Pancreatic juice. — The pancreatic juice is a liquid of which five per cent is made of *three ferments* which perform the main part of digestion. As the chyme comes from the stomach, it contains albumin, some already digested, but much only softened and broken up. It also contains fat and starch unchanged.

One of the ferments of the pancreatic juice, *trypsin*, acts upon the undigested albumin, changing it to peptone.

Another ferment, *amyllopsin*, changes the starch and

sugar to glucose. It does practically all the work of digesting starch and sugar.

The third ferment, *steapsin*, saponifies some of the fat with the soda and potash of the chyme. About one half an ounce of soap is thus formed daily. It acts as a lubricating and cleansing agent. The ferment also emulsifies the remainder of the fat.

117. Action of the bile. — About a quart of bile is poured into the intestine each day. It has a slight power in emulsifying fat, and in converting starch into glucose, but while its direct action is small, it does a great amount of work in helping and stimulating all the processes in the intestine. It almost doubles the power of the pancreatic juice. It acts as a lubricant to enable the food to slip down the intestine easily. It stimulates the peristalsis of the intestine, and prevents the growth of germs of fermentation. It also enables digested food to pass more readily from the intestine into the blood tubes. When bile is of poor quality, or too little in quantity, digestion is less perfectly performed, and headaches, mental dullness, and all the symptoms called *biliousness* result.

118. Peristalsis. — The intestine shows peristaltic movements like those in the esophagus. A half an inch or so of muscle fiber, running lengthwise of the intestine, contracts, pulling the next lower part of the intestine up over a lump of food. Then the circular fibers contract, squeezing the food down the tube, while the fibers next below repeat the process, as the first ring of contraction relaxes. So the contraction runs down the tube, forcing the intestinal contents before it.

This peristalsis is a slow, gentle movement. By it the intestinal contents are mixed with its juices, and slowly propelled toward the large intestine, where it is propelled still more slowly.

119. Result of intestinal digestion. — By the action of the three digestive fluids, the food is dissolved and reduced to a thin, milky form, called *chyle*. As all food contains many substances wholly indigestible, some solid particles will still remain in the chyle. Digestive action goes on during the whole time that food remains in the intestine, but most of the work is done in the small intestine. As it slowly passes down the tube, the liquid parts are taken up until, when it reaches the large intestine, it has become semi-solid again. The expulsion of the solid waste which finally remains is the last act of digestion. It takes about twelve hours for food to pass the length of the small intestine, and thirty-six hours to traverse the large intestine.

120. What becomes of the ferments. — After the ferments of the gastric, pancreatic, and intestinal juices have done their work of digestion, they are probably digested by the new ferments poured out at the next meal, for they are albumin. Bile is a waste product, yet some of its parts are taken up by the blood and carried to the liver, and again poured into the intestine. Thus nature is as economical as possible with the resources of the body.

121. Perfection of the digestive organs. — The mouth is perfectly adapted to masticating just such food as the stomach can readily digest, while it cannot grind such food as corn or hay. The stomach seems a weak, flabby organ, but nature made it of just the right size and strength to do its own proper work.

The bile is a waste product of the body and yet it is one of the most important agents in digestion. In brief, each part of the digestive system is perfectly adapted to its own work. In lower animals the digestive organs are somewhat modified so as to adapt them to different foods and different modes of eating.

SUMMARY

1. From the stomach the food passes into a long, coiled tube called the *intestine*.
2. In the intestine the food is acted upon by ferments in three fluids: the *intestinal* juice, the *pancreatic* juice, and the *bile*.
3. The intestinal juice has a slight action in changing starch to sugar, and albumin to peptone.
4. The pancreatic juice does the main part in changing starch to sugar and albumin to peptone, and of emulsifying and saponifying fats.
5. The bile greatly increases the power of the pancreatic juice. It also lubricates the intestine, prevents fermentation, and aids the passage of digested food into the blood tubes.
6. The muscles of the intestine slowly force the food down the tube so that it takes about twelve hours for food to traverse the small intestine, and thirty-six to traverse the large intestine.

DEMONSTRATIONS

43. Open the abdomen of a dead animal. Notice the thin, gauze-like omentum containing lumps of fat, and enveloping the intestine. Lift it up, and notice that the upper part of the large intestine seems to be inserted through it as though it were split into two leaves. Notice the difference between the small and large intestine in position, shape, and movability. Notice the beginning of the large intestine and the cæcum. The vermiform appendix can usually be found also. Notice the position, size, and feeling of the liver, and the gall bladder beneath it. By careful search the pancreas can be found behind the stomach, lying crosswise of the body, flattened out upon the backbone. It is covered with peritoneum and fat, and so is obscured, but can be recognized by its nodular appearance. A pig's sweetbread has much the same appearance as a man's pancreas. (See demonstration 35.)

Notice the thin fanlike mesentery, holding the coil of intestine in place. Notice the blood tubes running across it. Open the intestine for a few inches to show the folds of the valvulæ conniventes.

44. The villi are too soft and too small to be seen without a specially prepared specimen. A magnifying power of 50 will show them.

Examine also a specimen of the liver, using at first a power of 100 diameters. Notice the capillaries converging toward central veins. The bile ducts are too fine to be seen.

Next use a power of 400 diameters, and examine the cells carefully. Notice their large size, and that they sometimes have more than one nucleus. Make a sketch of a villus and of the liver cells.

45. Pour some oil into a bottle of water. Shake well, and notice that the two cannot be made to mix. Now add a small pinch of *pancreatine*. Shake once more, and notice that the oil now forms an emulsion with the water.

Explain that the pancreatine contains the ferment of the pancreatic juice, and that it has the same action outside the body that it does inside.

46. Make a little starch paste. While it is warm stir in a small pinch of pancreatine. In a few minutes the paste becomes fluid from the conversion of starch to sugar.

47. Procure some bile. That from a chicken's gall bladder will do. Pour some into a bottle with oil and water, and notice that it forms an emulsion.

REVIEW TOPICS

1. Describe the intestine and its various divisions—the small and the large intestine, the cæcum, the vermiform appendix, the colon, the mesentery, and the omentum.
2. Describe the pancreas.
3. Describe the liver.
4. Describe the bile and its uses.
5. Describe the pancreatic juice and its three ferments, and their uses.
6. Describe the intestinal juice and its use.
7. Describe the peristalsis of the intestine.

CHAPTER IX

ABSORPTION AND ASSIMILATION

122. Absorption of food.—Digested foods which become part of the body are *peptone*, *glucose*, and *emulsified fat*. While they remain in the intestine, they are still outside of the body proper. In order to nourish the body, they must diffuse through the wall of the intestine and become part of the blood. The process of taking any substance into the blood is *absorption*.

The bodies of most cells are semi-fluid and jellylike. The peptone and glucose, dissolved in water, will soak into the soft epithelial cells lining the intestine, while the original albumin and starch or sugar will not. Blood tubes run so near the inner surface of the wall of the intestine, that only a layer of epithelium and the capillary wall, both together thinner than the thinnest paper, separate the blood from the food in the intestine. The food soaks through the epithelial cells and the walls of the blood tube, and is washed away by the blood stream. So there is a steady flow of digested food through the epithelial cells toward the blood tube; while the undigested food remains behind. The cells are alive, however, and to a degree select what they transmit. Common salt is necessary in the process, and bile greatly aids it. Peptone and glucose are thus absorbed from the intestine by every point of its mucous membrane. The millions of villi projecting into the intestine greatly increase the surface for absorption,

while their thin walls are especially designed for the easy passage of fluid.

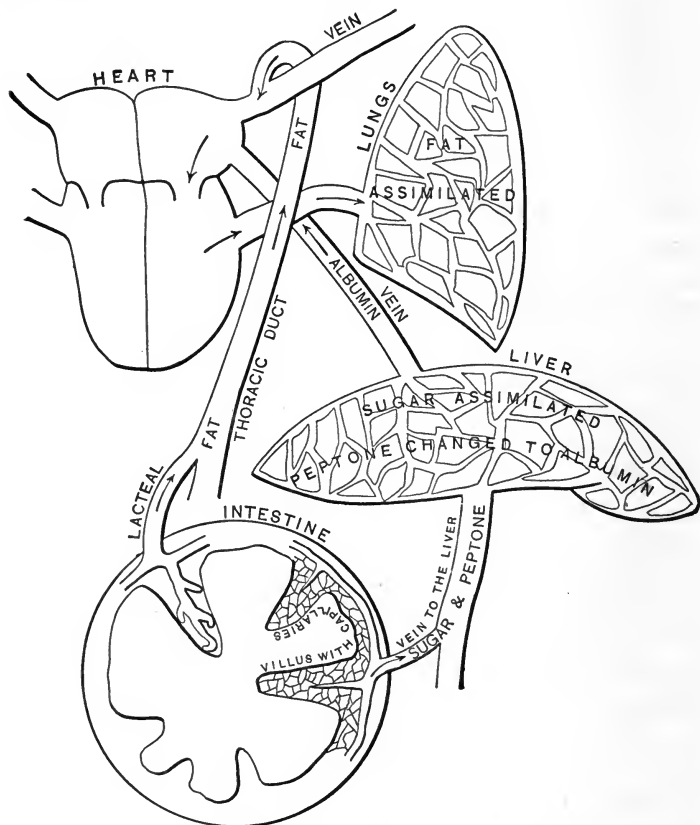

Diagram of the course of food in its absorption and assimilation.

123. Absorption of fat. — Fat also diffuses in the alkaline solution contained in the intestine. Under the microscope, particles of emulsified fat may be seen inside the epithelial cells of the villus. Only a small part enters the

blood tube of the villus, while its greater part enters the *lacteal* tube. These lacteals unite to form larger and larger tubes, which run across the mesentery, and finally open into a single tube, the *thoracic duct*, running up the spinal column. This is a tube as large as a goose quill, and opens into a large *vein* at the root of the neck, where emulsified fat from the intestine first reaches the blood.

124. Completion of digestion. — Reckoning the amount of saliva as two pints a day, of gastric juice as eight pints, of pancreatic juice one and a half pints, and bile as two pints, and of food three pints, the liquid introduced into the intestine daily amounts to two gallons at least, and nearly the same amount is absorbed. More and more of this liquid is absorbed as the food passes down the intestine, until, about twelve hours after eating, what is left of the food and digestive fluids reaches the large intestine in a semi-solid state. In the large intestine absorption and peristalsis are so very much slower, that from twenty-four to thirty-six hours are required for the remains of food to traverse it. Its water and digested food and some of the bile are absorbed, while the rest of the bile and its other waste products and undigested matter are left behind. In health the intestine expels the waste matter regularly at least once a day.

125. Assimilation of fat. — Changing the digested food into the various fluids and tissues of the body is assimilation. The thoracic duct pours the digested fat into a large vein on the left side of the neck, whence it is carried with the venous blood to the lungs. Little or no fat can be found in the blood leaving the lungs unless it has been eaten in excessive quantities. It is probably oxidized at once to carbonic acid and water, an ounce requiring three ounces of oxygen. It is unlikely that any fat from the food is stored up, but the fat in the body is probably derived from the albumin of the cells. The oxidation of fat produces *heat*, and the heat may be changed to power, or be used simply to warm the body.

126. Assimilation of glucose. — Glucose enters the blood in the villi, and is carried from there to the *liver* by means of a large vein called the *portal vein*. As the blood emerges from the liver, it contains almost uniformly $\frac{1}{1000}$ part of glucose, no matter what amount of sugar is in the portal vein. The liver contains a sugarlike substance called *glycogen*, which increases in amount after digestion, and almost disappears a few hours after eating. So it is thought that glucose is stored in the liver as glycogen, and given up to the blood in a steady stream.

In the blood the glucose is all oxidized to carbonic acid gas and water, giving out heat and energy. One ounce of glucose requires about one and one fifth ounces of oxygen to oxidize it completely.

127. Assimilation of peptone. — Peptone is a *poison* to the body and must be changed immediately after entering the circulation. It is carried directly to the liver by the portal vein, and there all becomes changed back to forms of albumin which will not diffuse through a blood tube, except under pressure. The liver further makes the albumin a living part of the blood. Some albumin is oxidized in the liver, but a large part is carried to the cells of the body. Each cell in the body is thus bathed in albuminous food brought to it by the blood.

Like an ameba, each cell chooses as much of the albumin as it needs for food, and, taking it in by any part of the surface of its body, makes it a living part of itself. Finally, even the living albumin of the cell is oxidized, an ounce requiring one and one half ounces of oxygen.

128. Absorbed poisons thrown out by the liver. — Fermentation in the intestine produces injurious substances, and the bile brings in waste matter. Decayed food, too, contains poisons. All these substances may be absorbed and

carried to the liver, which either destroys the poisons or sends them back to the intestine along with the bile. In this way the liver is a continual protection to the body.

129. Summary of the work of the liver. — The liver serves as the *regulator* of the body. The bile which it produces is to the intestine what the acid is to the stomach. It aids the action of the digestive ferments and hinders other forms of fermentation. It smooths the passage of food down the intestine, and aids diffusion into the blood tubes. The liver changes digested albumin and sugar and fits them for use in the blood, and intercepts poisons which may be circulating in the blood. Its work goes on constantly, and upon its perfect action depends the well-being of the body.

130. Biliousness. — If the liver acts imperfectly, a part of the peptone remains unchanged; other poisons, too, brought from the intestine by the blood are not destroyed; and the glucose is not properly assimilated and oxidized. A coated tongue, headache, loss of appetite, and an unconquerable feeling of dullness follow, and are symptoms of what is known as *biliousness*.

In fevers there is a poisoning of the body by the cause of the disease. As the liver is one of the principal organs which remove poisons from the blood, it may soon be able to get rid of them, and thus cure the fever. But often the task is too great for it, and then all the symptoms of a severe bilious attack are added.

131. Liver medicines. — Certain drugs, like *mercury* or *podo-phyllin*, have the power to increase the action of the liver. In proper doses they cause a great outpouring of bile which carries with it the poisons of the body. The drugs also cause the liver cells to assimilate the food more perfectly. Thus nature is *assisted* by the drugs and the biliousness is soon overcome.

132. Intestinal indigestion. — When the stomach is overworked and acts imperfectly, its work is thrown upon the intestine. Digestion there is imperfectly accomplished, and

fermentation takes place, with the development of poisons. The gas from the fermentation causes the abdomen to swell or bloat. The liver is imperfectly nourished, and is overworked in throwing out the poisons; so it fails to make the proper changes in food. Then the whole body, including the stomach, is weakened, and biliousness is produced. At last nature brings on severe sickness, and compels the overworked organs to rest.

133. Prevention of biliousness. — Man has it in his power to prevent almost entirely the evils of indigestion. He should eat only plain food, in moderate quantities, and at regular intervals. He should be careful not to eat when he is tired, or heated, or just before or after hard work. His digestive organs would then furnish a continual supply of perfectly digested food, sufficient for all the cells of the body; the influences producing disease would be resisted by well-nourished cells, and sickness would be rare.

134. Regularity of the bowels. — The last act of digestion, or the expulsion of waste matters from the intestine, is as important as eating, and should be performed with the same regularity. The mouth and stomach are endowed with feelings which make known their needs, but the intestine has only slight sensibility, and we are unaware of the digestion which is continually going on in it. Only when some irritating food, or a large collection of gas, greatly increases its peristalsis are we aware of its action. At a regular time every day a healthy person feels that the completing act of digestion should be performed, but the sensation will pass away if it is neglected, and in course of time the sensation will be repeated only once in two, three, or even more days. The retention of waste matter all that time cannot fail to do harm. Even if nature does not give the sensation indicating the need of expelling waste matter, the matters need to be expelled,

and the opportunity should be given daily at a regular time. Even if little food is eaten, the waste matters are still formed, and need expulsion. It should be remembered that it requires two days for food to pass the length of the intestine, so refraining from food only a single day does not make the intestine empty.

When the intestine expels its contents too freely, there is usually some irritating food which it is trying to expel. So a dose of medicine, which will aid in its expulsion, is required rather than something which will restrain the action.

135. Proper food. — The stomach may be able to begin digesting an improper meal, while the intestine is unable to finish the work. Owing to the slowness with which the intestine acts, several meals may be eaten before its failure becomes noticeable. Then the last meal is blamed, instead of the offending meal. So persons may gain wrong ideas about the digestibility of various articles of food.

136. Headaches. — A headache is generally due to disturbances in digestion. Usually when the liver is stimulated by a proper medicine, the headache ceases. Even if the headache is due to overwork, probably it would not have come on if the digestive organs had been performing their work properly.

SUMMARY

1. The peptone and glucose are taken up by the epithelial cells of the villi, and passed on to the blood in the capillaries inside the villi.
2. Emulsified fat is taken up by the epithelial cells of the villi, and passed on to the lacteals within the villi. From there it goes to the thoracic duct, and finally is poured into the large vein at the root of the neck.
3. About two gallons of fluid enter and leave the alimentary canal each day.

4. The fat is carried to the lungs, and is there oxidized to carbonic acid gas and water, each ounce of fat using nearly three ounces of oxygen.
5. The glucose is carried to the liver, and from there is given out in a steady stream and oxidized to carbonic acid gas and water, each ounce using a little more than an ounce of oxygen.
6. The peptone is carried to the liver, and there is changed back to the form of albumin adapted to the blood and tissues of the body.
7. In the liver some albumin is oxidized, and the rest is sent out as a part of the blood to feed the cells.
8. Poisons are often absorbed with the food, and are carried to the liver. But the liver cells separate out the poisons, and either destroy them or expel them with the bile.
9. By intemperate eating the stomach is disordered. Then more work is put upon the intestine, until it fails in its duties. Then the liver has imperfectly digested food and more poisons to take care of. Then a poor quality of bile is poured out. Then the intestine fails still more in its work. So the circle of cause and effect goes on, all depending at first upon intemperate eating.
10. The last act of digestion, or the expulsion of waste matters, should be attended to regularly every day.

DEMONSTRATIONS

48. Show the absorption of food in a young kitten or puppy which had been fed with cream about two hours before being killed. Place the animal in a tight box along with a sponge containing half an ounce of chloroform. In a few moments the animal will be dead. At once open its abdomen and spread out its intestine. Across its fanlike mesentery will be seen white lines. These are lacteals, which

are carrying the emulsified fat from the intestine. The fluid looks like milk, and so the name *lacteals*, or milk tubes, was given to the tubes. (See demonstration 35.)

49. Probably some boy in the schoolroom who is suffering with a bilious attack will be willing to show his tongue to the class. Notice that it is covered with a thick white or yellow fur. Explain that the tongue is a part of the alimentary canal, and that the stomach and intestine are in a like condition. Explain that, when the rest of the alimentary canal is acting well, the tongue is clean and the breath sweet.

REVIEW TOPICS

1. Describe the diffusion of digested food into the blood.
2. Trace a particle of digested fat from the intestine to the blood, and tell what finally becomes of it.
3. Describe how the liver uses digested sugar.
4. Describe how digested albumin becomes a part of the blood, and tell of what use it is to the body.
5. Tell how the liver removes poisons from the absorbed food.
6. Tell how a disturbance of digestion, in either the stomach, intestine, or liver, disturbs each of the other organs.
7. Show that each organ of digestion is perfectly adapted to its own work.

CHAPTER X

ALCOHOL AND DIGESTION

137. Summary of the action of alcohol. — The action of strong alcohol outside of the body is threefold. First, it takes away water from substances which it touches; second, it hardens and coagulates albumin; third, as a result of the first and second actions, it impairs or destroys the life of cells and of ferments with which it comes in contact. Alcohol harms the body in these ways and also has special effects upon parts which it does not touch.

138. Effects upon food. — Alcohol produces changes in food in direct proportion to its strength and amount. If the alcohol be strong, and large enough in amount to saturate the food, then it may harden the albumin and render it more difficult of digestion. It may also prevent the pepsin of the stomach from acting. The habitual drunkard may take strong drink in sufficient amount and strength to produce this change in his food.

139. Effects upon the mouth. — In the mouth alcohol may take water from the epithelial cells, and give rise to a sense of thirst. Although the alcohol may be mixed with enough water to satisfy natural thirst, yet it causes a false thirst to arise, which demands another drink.

140. Effects upon the gastric juice. — When it reaches the stomach, a very strong alcoholic drink has a marked effect upon the gastric juice. The essential digestive agent in the gastric juice is pepsin, which is a lifeless albuminous ferment. The alcohol in any common form

of strong drink is in sufficient quantity to hinder or to stop the digestive action of the pepsin. But when the alcohol is absorbed or diluted, the pepsin can act as well as ever.

141. Effects upon the mucous membrane.—Alcohol irritates the mucous membrane of the stomach. Then more gastric juice is produced in order to dilute the irritating alcohol. Thus the effect of the alcohol may be somewhat overcome by the increased quantity of the digestive fluid. But the alcohol may cause an increased flow of mucus also, just as a cold causes the pharynx to produce more mucus. The mucus may coat the particles of food, and prevent the gastric juice from acting on them. This is especially apt to happen when strong drink is taken continuously in small amounts, and for long periods. In such conditions both the quality and quantity of the gastric juice may be impaired.

A drink, such as even a moderate drinker often takes, may produce redness, swelling, and inflammation of the stomach. The effect is far greater when the drink is swallowed upon an empty stomach, for then there is no food to protect the mucous membrane from the direct action of the strong drink.

142. Effects upon peristalsis.—The irritation of the alcohol at first causes an increased action of the stomach walls, so as to force the harmful substance away. Continuous use of strong drink is likely to weaken the muscles and to make peristalsis much less. Then the food is less perfectly mixed with the gastric juice and is not ground to pieces, but remains too long in the stomach undigested. The water and mucus poured out diminish the strength of the alcohol, and this, together with the poor quality of the gastric juice and the long stay of food in the stomach,

permits fermentation to take place. Thus alcohol disturbs every action of the stomach, and often produces the worst forms of indigestion.

It is true that a little weak alcoholic drink will not produce all these evil effects at once. Herein lies the danger. Alcohol is a deceitful thing. Though the stomach gives notice that it is abused by the drink, yet the mysterious thirst demands still more alcohol, and bribes its victim with the memory of its pleasant sensation. So the poor stomach suffers time after time, and before long becomes permanently crippled.

143. Protection against alcohol. — When an alcoholic drink is taken into the mouth, it irritates the mucous membrane. This causes the saliva to flow and dilute the alcohol, so that at any one time it can do very little direct harm. In the stomach it causes the gastric juice to flow in the same way, and thus it soon becomes dilute and has little direct effect. Even if the pepsin should separate from the gastric juice, in a little while the ferment will dissolve in the increased quantity of juice and perform its work well again. Nature may thus protect the body for some time, but it cannot remove the danger.

144. Effects of alcohol upon the intestine. — By the time alcohol reaches the intestine, it is usually too dilute to produce much direct harm. But if it has deranged stomach digestion, the work of digesting the food falls upon the intestine. Thus intestinal digestion may be imperfect. Alcohol itself is probably not changed by digestion. In its diluted form it is quickly absorbed. Even when a large amount is absorbed, little or none can be found in any of the tissues or blood tubes. The only probable way of its disappearance is by oxidation before it can pass beyond the liver.

145. Effects of alcohol upon the liver. — Alcohol affects the liver in three ways. In the first place strong drink is apt to induce stomach and intestinal indigestion. Then the liver must do an extra amount of work in completing the imperfect digestion. Thus biliousness is often produced.

If drinking is continued, the liver trouble is likely to persist.

In the second place the destruction or oxidation of alcohol uses a large amount of oxygen which the liver should use in assimilating food. Thus food is imperfectly oxidized. While no products in the body can be traced directly to oxidized alcohol, yet when alcohol is used poisonous products of imperfectly oxidized albumin are always abundant. These products circulate through the whole body and produce far more harm than the original alcohol. (See p. 152.)

In the third place the liver cells are directly affected by these abnormal actions. Long-continued drinking often results in an incurable wasting away and hardening of the liver tissues.

146. Unintentional forms of drinking. — There is a form of alcohol which is used by many innocently and unintentionally. Many a well-meaning person habitually uses "Strengthening bitters" after meals, ignorant of the fact that they are only bitter herbs dissolved in alcohol and water. Each dose is equivalent to a large drink of whisky.

Essence of Jamaica ginger is only ginger dissolved in alcohol, and its effects are due mainly to the alcohol, and not to the ginger.

147. Intemperance in eating. — There is a common intemperance of eating too much starch and sugar. These substances can never be digested, absorbed, and oxidized with sufficient rapidity to produce the intoxicating effects of alcohol, but their excessive use deranges the liver in the same manner as alcohol. In the first place, starch and sugar are likely to ferment and produce a sour stomach and intestinal indigestion; this is probably the most common cause of biliousness.

In the second place, when too much sugar or other food is oxidized too little oxygen is left for the albumin

of the food, then the products of incomplete oxidation resemble those produced by alcohol; but they usually produce no more than a sick headache or an attack of biliousness, although under aggravated and repeated conditions they may endanger life. (See p. 34.)

In the third place, the effect of a continual excess of food is to injure the liver cells permanently. Even the wasting away and hardening called "gin drinker's liver" may be caused by intemperate eating. Intemperance in eating differs from the intemperance of strong drink in the *quantity* of effects produced rather than in their kind.

SUMMARY

1. Alcoholic drinks take water from the mucous membrane of the mouth and so increase the thirst, even if the body contains sufficient water.
2. In any considerable amount alcohol hardens the pepsin in the stomach, and so prevents its acting upon the food.
3. Alcohol irritates the mucous membrane of the stomach so that it becomes inflamed and unable to produce the gastric juice. Then the intestine is overworked in digesting what the stomach should have digested.
4. Alcohol is quickly absorbed by the intestine. It is quickly destroyed, probably by oxidation, before it passes the liver.
5. Because oxygen is used in the destruction of alcohol, incomplete and poisonous products of the oxidation of albumin are formed. These go through the whole body and greatly increase the harm done by alcohol.
6. Bitters, and essence of ginger contain much alcohol.
7. When starch and sugar are eaten in large amounts, they use oxygen which should oxidize the albumin.

So they can produce slowly the same kind of effects as alcohol.

DEMONSTRATIONS

50. Hold some common salt in the mouth, and at once saliva flows to dilute it. In a moment it can be held with comfort. Explain that this is a provision of nature to protect the body from any irritating substance. The stomach may pour out an excess of gastric juice in the same manner so as to protect the body against alcohol and other irritating substances. Call attention to other similar ways in which nature protects the body, as in the flow of tears to wash away a speck of dirt from the eyes.

51. Prepare two bottles to show artificial digestion (see demonstration No. 40). In the second one replace a quarter of the water with alcohol and notice that no digestion takes place in this bottle. Explain that this experiment may be misleading, for in the stomach more gastric juice will flow to dilute the alcohol until the pepsin can act as well as before. Explain that alcohol does not destroy the pepsin, but when the alcohol is diluted, the pepsin is as good as ever.

REVIEW TOPICS

1. Give the three characteristic actions of alcohol outside the body.
2. Give the action of alcoholic drinks upon the mouth.
3. Give the action of alcoholic drinks upon the mucous membrane of the stomach; upon its secretions; and upon the peristalsis of the stomach.
4. Tell why alcoholic drinks have but little direct action upon the intestine and upon the villi.
5. Give the action of alcoholic drinks upon the liver.
6. Explain why bitters and essence of Jamaica ginger are both harmful.
7. Explain the effects of intemperate eating.

CHAPTER XI

DIGESTION IN LOWER ANIMALS

148. Digestion in dogs.—All four-footed animals have essentially the same digestive organs, secreting the same juices as man. Their food, also, is absorbed and assimilated in the same way, but there are slight modifications according to the kind of food eaten. A dog's stomach and intestine have thicker walls, and their juices have far more digestive power; so dogs can digest even bones, which form one of their regular articles of diet.

149. Digestive organs in cattle.—A horse lives upon hay, which man cannot digest at all. Cattle have an arrangement which enables them to gather a large amount of food at once, and then to chew it at leisure. As grass is eaten, it is swallowed almost whole. It goes first to a small intermediate stomach, and then to a large pouch called the *paunch* or *rumen*, which in an ox holds about two bushels. When this is full, the animal lies down and proceeds to chew the food. It forces the food back into the mouth in small masses, called the *cud*, which it chews and swallows again. But this time the food is guided on to a third stomach, whence it soon passes into the fourth. The fourth stomach corresponds in size and shape to man's, and is the true digestive stomach, while the others are only storehouses and passageways for the food.

150. Digestive organs in birds.— Birds swallow their food whole, for they have no teeth or strong jaws for chewing. It first enters a pouch called the *crop*, where it is soaked in a fluid secreted there. It slowly passes on to the stomach, where it is mixed with the gastric juice. Then it passes into a muscular bag called the *gizzard*. The walls of the gizzard are from one fourth to one half an inch in thickness, and its lining is a thick, tough membrane. It contains small stones which have been swallowed. Its thick walls roll the food about with the stones, so as to grind it to pieces and mix it with the gastric juice. Then it passes into the intestine, where its digestion is completed, as in man.

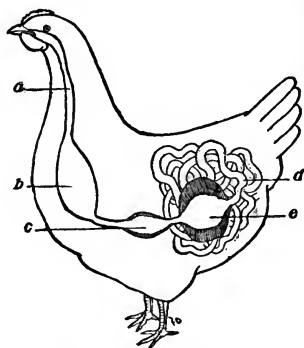

Digestive organs of a bird.

- a* esophagus.
- b* crop, or crop.
- c* stomach.
- d* small intestine.
- e* gizzard.

151. Digestive organs in insects and worms.— Insects possess a stomach and intestine which secrete digestive juices. They also have organs like the liver and pancreas. Some insects masticate food, and others possess a gizzard, which grinds the food after it is swallowed.

Worms generally possess a digestive tube which extends straight through the body. Shellfish, as oysters and clams, possess a stomach and a coil of intestine, which passes through the heart. The large, dark-colored, rounded mass at the back end of the oyster and clam is the *liver*.

152. Energy required in digestion.— Man's food requires but little energy in its digestion, hence most of his energy can be applied to physical and mental effort. To digest dog's food requires

more energy; to digest the food of cattle requires still more. The lower the form of life, the more time and energy is spent in digestion, and the less is the action of other parts, until the lowest forms of animals simply live to eat, and remain at rest except when eating food. A comparison of man's digestion with that of the lower animals is misleading. Man's alimentary canal is designed to deal with food upon which but little energy need be expended. More energy is thus available for his voluntary use. Because of his perfect food man can perform more labor and undergo more fatigue and exposure in proportion to his size than any other animal.

SUMMARY

1. The digestive organs of all animals are similar to man's, but modified according to the needs of the animal.
2. Cattle swallow grass whole, and then chew it at leisure. They have four stomachs.
3. Birds swallow food whole. It passes first into the crop, and later is ground in the gizzard.
4. Insects, worms, and shellfish each possess a simple stomach and intestine.
5. Man uses food which is more easily digested than the food of any lower animal. Thus he devotes less time to mere eating and digesting food.

REVIEW TOPICS

1. Show in what way and for what purpose a dog's digestive organs differ from those in man.
2. Show the use of four stomachs in cattle.
3. Show how birds digest their food.
4. Point out how the digestive organs are modified in worms; in insects; and in shellfish.
5. Show what advantage man's food gives him over the lower animals.

CHAPTER XII

ANIMAL FOOD

153. Food elements. — Anything which, taken inside of the body, supplies it with weight, heat, or energy is food. Man's food consists of a great variety of substances derived from the animal, vegetable, and mineral kingdoms. Yet all food consists of the proximate principles: water, mineral matter, albumin, fat, and starch or sugar. Neither alone makes a perfect food, but all must be present in proper proportions or else the body will suffer.

154. Water. — Water requires no digestion, but is continually entering and leaving the body unchanged in form. All solid food contains some water, and enough more is added in liquid food and in drink to supply the full needs of the body. Twelve or fifteen pints of fluid are used daily in the work of digestion, but it is absorbed back again to the blood and so little is lost. Within reasonable limits, water taken at meal times aids digestion. In order to digest food and wash away waste matter properly, two or three quarts must be swallowed daily. If the thirst is satisfied with pure water, there will be little danger of taking too much, and the indications of thirst will be the most reliable guide as to the times of drinking and of the quantity required.

155. Mineral matters. — Mineral matters are not changed during digestion, and they leave the body in the same form in which they enter. More than enough are found in all

ordinary food to supply the needs of the body. Only salt needs to be added to food, but man often adds far more than is necessary. Since water and mineral matters require no digestion, it makes little difference in what kind of food they are eaten. But albumin, fat, and starch or sugar require digestion, and some forms are more easily digested than others, so a discussion of their forms in different foods becomes necessary.

156. Digestibility of food. — In judging of the value of food four things must be considered :

First. The time and energy required. — Some forms of food require little or no energy in their digestion, while others cannot be digested at all. Grass contains all kinds of food substances, but man cannot digest it. The combination of meat, fruit, and flour which we call mince pie requires far more time and energy in its digestion than the same substances in the form of roast meat, bread, and fresh fruit, or in the form of a light pudding.

Second. The amount of indigestible matter. — All kinds of food contain some matter which is wholly indigestible. Only a little of fruit is digested. Careful experiments show that ordinarily at least one fifth of the albumin of vegetable food passes through the intestine undigested, while only one thirtieth of meat is thus wasted. Animal oil is easily emulsified and saponified, while vegetable oil can scarcely be changed at all, but if eaten in any quantity is a source of intestinal disturbance. Some wholly indigestible matter in food is valuable, for it affords something upon which the intestine can contract so as to force its contents down the tube.

Third. The amount of energy developed by the food. — Fat requires a large amount of oxygen in its oxidation, and yields a large amount of heat and energy. Sugar

requires only one third as much oxygen and develops less heat and energy. So food rich in fat yields more heat and energy than a food rich in sugar or starch.

Fourth. Liability to ferment.—A food requiring a long time in digestion is more liable to ferment than one which is digested in a short time. Sugar and starch ferment easily, while fat ferments only with difficulty.

✓ **157. Milk.**—Among all the different kinds of food milk seems to be most perfectly adapted for man and for many animals. The average cow's milk consists of

Water	86 per cent.
Albumin	4 “
Fat	4½ “
Sugar	5 “
Mineral matter	½ “

Milk thus contains all the five different kinds of food substances, which, moreover, are in about the proper proportions to support life best.

The albumin, fat, and sugar of milk each requires little time and energy in its digestion, and leaves but little undigested residue. Milk is more liable to undergo fermentation than some other kinds of food, but the quickness of its digestion overcomes this objection. It develops heat and energy in amounts best suited to support life. Milk is thus an ideal food, and can be digested when all other kinds of food are rejected.



Fat globules in milk
(× 300).

158. Caseine.—The albumin of milk is called *caseine*. In its digestion the rennin ferment in the stomach coagulates it in fine flakes, which the acid and pepsin dissolve to peptone. When much acid is present in the stomach, as after a meal, or when fermentation has occurred, the caseine is apt to be coagulated in hard lumps which dis-

turb digestion, producing a bilious attack. The rennin ferment is produced the more rapidly when milk is hot, while the heat hinders the production of the acid of the gastric juice. So if the milk is taken hot, it will be coagulated in finer flakes, which the gastric juice can digest more easily. If milk is taken slowly in any form, it is coagulated in small amounts as fast as it enters the stomach, and so no large lumps can form. If taken before meals, hot and slowly, there are but few persons with whom milk will disagree.

159. Fermentation of milk. — Many kinds of living germs are continually falling into milk and growing, if the temperature is warm. Some are germs which produce acid fermentation and turn the milk sour. The acid coagulates the caseine, forming *clabber*. Germs of disease also will grow in milk, especially germs of typhoid fever and of tuberculosis. Children are very easily affected by sour milk. Often the germs of fermentation grow in their stomachs, souring the food and producing *summer complaint*. Heating the milk steaming hot destroys most of the germs, but not the poisons which have already been produced. All cow's milk given to babies should be heated almost to the boiling point in order to destroy the germs.

160. Cheese. — Rennet is often added to milk in order to coagulate its caseine, which, when squeezed into a firm mass, is *cheese*. The cheese holds the fat of the milk, while the sugar remains in the whey. Cheese is about one third albumin. It contains no sugar or starch. The amount of fat which it contains depends upon how much cream was left in the milk of which it was made. It is a valuable article of food because of the large amount of albumin always present. It is easily digested by healthy persons. In some kinds germs are permitted to grow and develop various acids and flavors which make the cheese *strong*. These are somewhat harmful, but mild cheese furnishes a cheap supply of good albumin.

161. Butter. — When milk remains quiet for some hours, the fat rises to the surface in the form of *cream*. After this is removed, milk is called *skim milk*. Cream is made up of fine particles of fat, each surrounded by a thin envelope of caseine. When cream is shaken until the covering of the caseine is worn off, the fat collects in a form called *butter*. The liquid part remaining is called *buttermilk*, and does not differ much from milk, except that the fat is mostly removed. Butter is the most valuable form of fat eaten.

162. Value of milk. In sickness milk is almost the only food which the stomach can digest at all. Only about one twentieth of the solid part of milk fails to be digested. When only milk is taken, there is but little residue upon which the intestine contracts, and so waste matters pass down the tube more slowly than when solid food is eaten. Those who eat much milk find it profitable to eat heartily of substances which, like oatmeal, leave a large undigested residue to sweep out the waste matters of the intestine.

163. Adulteration of milk. — It is difficult to set a standard for perfect milk, for no two cows give it of exactly the same composition. Milk which has a good quality of cream usually contains a good quantity of albumin and sugar and so is said to be *rich*. Such milk is yellow, in distinction from the bluish color of poor or *skim milk*. The richness of milk may be measured by observing how thick a layer of cream will rise in a deep glass tube full of milk. Another way is to determine how much solid matter the milk contains by means of a *lactometer*. This is a closed tube weighted so that it will float upright. As more solid matter is dissolved in the milk, it becomes heavier and will more easily sustain a body floating upon it. The richer the milk, the less the bulb and tube will sink. This instrument is called a *lactometer*. By means of it milk brought into large cities is tested by government inspectors, and all milk which falls below a certain standard is thrown away. The lactometer really records the specific gravity of the milk. If it falls below 1.029, it is considered to be either watered

or of too poor quality to be sold as good milk. While such milk may not be injurious, yet it is a fraud to sell it at the price of good milk. Skim milk is bluish in color from the loss of its cream. To make it the color of new milk, burnt sugar is often added, and it is then sometimes sold as new milk. It is very apt to become sour from its being kept for some days.

164. Condensed milk.—Large quantities of milk are boiled until its water is evaporated and the milk is like thin jelly. This is *condensed* milk. In order to keep it, sugar is added. Condensed milk contains all the nourishment of new milk, with some sugar added. It can safely be used in place of new milk for all cooking purposes. It is too sweet to be used as a drink, but babies take it readily. Still it is undesirable as a baby food, for it contains too much sugar.

165. Imitation cheese and butter.—Cheese made from skim milk contains but little fat. It easily ferments and becomes dry, so that it is very indigestible. There is an imitation of butter made from beef fat, called *oleomargarine*. It scarcely can be distinguished from real butter. *Butterine* is another imitation of butter made from beef fat and butter. The manufacture and sale of both kinds of imitation butter are permitted so long as the products are sold under their right names.

166. Eggs.—Hens' eggs consist of

Water	70 per cent.
Albumin	15 “
Fat	14 “
Mineral matter	1 “

Since they contain no starch or sugar, they are not a complete food for man, although a perfect chicken may be formed out of the egg, as the hen furnishes heat. The white of egg is almost pure albumin dissolved in water. The yolk is a mixture of albumin, fat, and water. Both the albumin and fat of eggs are digested with little expenditure of time and energy, and develop a large amount of heat and energy in their oxidation. They do not easily ferment in the stomach and intestine, and only about one

thirtieth is left over in their digestion. They are thus a valuable food, but yet do not rank so high as milk.

167. Digestion of egg albumin. — When boiled for a minute or two, the albumin of eggs is partly coagulated to a soft, jellylike mass. Boiling for three minutes coagulates all the albumin to an elastic, slippery mass; while after boiling for ten minutes the albumin becomes brittle, and is easily crushed to fine particles.

A lump of albumin of a raw egg is digested with less expense of time and energy than the same sized lump of coagulated albumin, and the longer an egg is boiled the more energy is required to digest it back to a liquid form. But the raw egg has a tendency to collect in masses which the gastric juice cannot penetrate.

An egg boiled for less than five minutes is usually masticated only to medium-sized particles, which, however, owing to their smaller size, may be digested sooner than the large masses of raw egg. But the egg boiled for ten minutes is easily chewed fine, and, owing to the still smaller size of its particles, is digested much sooner than small lumps of soft-boiled eggs or the masses of raw eggs. Thus an egg boiled for at least ten minutes is ordinarily the most available for digestion. When mixed with a considerable quantity of milk, the raw egg is prevented from forming a lump, and in this form it may digest more easily than a cooked egg.

168. Quality of eggs. — Fresh eggs vary but little in composition. In time they lose a little water by evaporation through the shell, which is porous. A fresh egg appears clear and pink when held in front of a strong light, while an old egg appears dark-colored, even if it has not begun to decay. It will first show a dark spot where the yolk settles to the side of the shell, and later will be dark all through. This test is reliable and is often applied in markets. The shell of a fresh egg is bright in color and slightly rough like common newspaper, but an old egg becomes duller in color and shiny in appearance like writing paper. Ducks' eggs are nearly like hens' eggs, except that sometimes they acquire a peculiar taste from the ducks' food. Nearly all kinds of birds' eggs, as well as the eggs of turtles, are used as food. They differ but little from hens' eggs.

169. Meat. — The flesh of oxen, sheep, and hogs is the common form of meat. All kinds of game, fowl, fish, and

shellfish are of the same nature. The muscles form the lean part of meat, but nearly every part of the animal is sometimes used as food. Average meat consists of

Water	65 per cent.
Albumin	17 ‘
Fat	14 “
Mineral matter	4 “

Albumin is the principal part of meat. Beef has high food value; mutton, fowl, and game rank next, in the order named.

✕ 170. **Digestibility of meat.**—Meat varies greatly in composition and digestibility. While man cannot digest stringy connective tissue and tough skin at all, yet good meat ranks next to milk and eggs, and exceeds all forms of vegetable food in all the four points of digestibility. It requires a small outlay of time and energy in its digestion, and its oxidation develops a large amount of heat and energy. It does not easily ferment, and only about one thirtieth remains undigested.

Meat is often salted or smoked or dried, or prepared in other ways so that germs of fermentation or decay will not grow in it, and thus it can be kept for a long time. When thus prepared, its fibers are partly coagulated and hardened, so that the gastric juice cannot penetrate them readily. The digestibility of such meat is greatly impaired. The toughness of meat is due to strings of connective tissue, which are digested with difficulty and yield little heat and energy to the body. Tender meat consists almost wholly of muscular fibers, which are the main nutritive parts of most meat. Since meat contains no starch or sugar, some must be added in order to make it a perfect food; and, very properly, bread is generally used.

171. Soup and beef tea. — The water in which meat is cooked is often eaten as *soup*. Soup contains some gelatine and fat, but only a small amount of albumin, for most of the albumin is coagulated by the heat, and thus prevented from dissolving. The water also dissolves the mineral and waste matters of the meat.

Beef juice is made by heating the meat and pressing out the juice. The best meat juice contains albumin and fat in about the same proportions as milk.

Beef tea is a kind of concentrated soup. Mineral and waste matters give it flavor. It is very poor in albumin and fat, and is of little value as a food, while its waste matters may render it harmful. There are no facts to warrant the assertion that beef tea contains some nutritious essence of the meat which is of special value as food. Its value must be judged solely by the amount of albumin and fat which it contains. Extracts of meat are sold, a teaspoonful of which added to a cup of water is said to contain the nourishment of a pound of beef. They consist of mineral and waste matters dissolved in water, and so are of no value as food. Their taste may be pleasant, and this may assist in the digestion of other food.

172. Fresh meat. — As a rule any meat is most wholesome if it is eaten soon after being killed. In the markets beef is usually hung in a room whose temperature is nearly freezing. There it remains fresh for weeks, or even months, and at the same time it becomes more tender and improves in flavor. When taken out and exposed for sale, it spoils much sooner than newly killed beef. If there is the slightest musty or decayed odor about meat, it is undesirable as food.

Game animals are often hung just as they are killed, until they are distinctly decayed, so as to develop peculiar flavors. Fowl and game are liable to be unwholesome if they are kept for many days without being opened and cleaned.

173. Points of good meat. — (1) Tender meat usually comes from well-fed animals, and such animals are always fat. A layer of fat from one fourth to one half inch in thickness, covering the outside of the meat just under the skin, usually denotes a well-fed animal. The

fat will also extend in fine white streaks irregularly in every direction through the meat and can be clearly seen upon its cut surface.

(2) The fat is deposited in the connective tissue which incloses separate bundles of muscles. If these bundles are from one eighth to one fourth inch in diameter, and preserve their shape when the finger is passed over them, they contain much connective tissue, and the meat is tough, as in meat from the neck. When a slice of such meat is gently pulled apart, the bundles separate from each other, and are connected together by strong, veil-like meshes of connective tissue.

On the other hand, if the bundles of muscle are small and not well marked, the connective tissue is small in amount. When a slice of such meat is pulled apart, its bundles do not separate, but the whole piece stretches.

(3) The cut edge of good beef soon becomes *bright red* in color. When the connective tissue is abundant between the bundles, it imparts a paler tint to the meat, and sometimes a bluish tinge. Good pork and veal are pale or almost white in color, but in other points resemble beef (see p. 218).

Good meat has an agreeable odor and is clean. Excepting as it is marked by connective tissue and fat, it should be of a uniform tint.

174. Fish. — Fish contains albumin about sixteen per cent, fat about six per cent. It is digested with rather less ease than meat, but it can take the place of meat as food. It used to be thought that it contained more nourishment for the brain than other kinds of food, but the brain is nourished by the same substances as the rest of the body, and fish is hardly so good for it as beefsteak.

Fish should always be eaten while fresh, for it is especially liable to decay.

175. Shellfish. — Shellfish, as oysters and clams, contain about sixteen per cent of albumin and three per cent of fat. The large dark mass in their bodies is the liver, which contains some sugar. When eaten raw, their own digestive fluids and their livers aid in the digestion of their bodies. When cooked, they require more time and energy for their

digestion. Because of their ease of digestion, fresh raw oysters are a valuable food in sickness. Crabs and lobsters also are good food if well cooked.

176. Blood. — Blood is digested with difficulty. It contains little albumin and fat and no sugar. It adds nothing to the value of meat, and is very liable to decay. It should always be removed, as is usually done in killing the animal. By the law of Moses the Jews were forbidden to eat the meat of animals which had not been bled to death.

177. Inferior meat. — Meat cannot be adulterated, but inferior meat is sometimes sold as good meat. Old meat is sold for fresh meat, and tough meat for tender. Very young animals are dangerous as food, and yet they are often sold. Meat from sick animals is always unfit for use. In France, horseflesh is sold for food under its own name, and in this country it is sometimes substituted for beef in cheap shops.

178. Diseased meat. — Meat sometimes contains living germs, which may produce disease in those who eat it. The most common disease to be feared is *tuberculosis*, or *consumption*. Beef cattle are especially liable to have the disease, which may be located in their muscles as well as in any other part of their bodies, and is difficult of detection.

A *tapeworm* passes one stage of its existence in the muscles of an animal. Its eggs are accidentally eaten by an animal, and develop into minute worms, which pass through the walls of the stomach into the muscles and there form white cavities about the size of a pin head, in which they lie quietly. When flesh containing such a worm is eaten and digested by man, the worm is set free from its cavity, and, fastening itself to the inside of the intestine, grows to many feet in length. It lays eggs which will grow only when eaten by a lower animal.

In pork there are sometimes found microscopic worms called *trichinæ*. In the muscles of man they may grow and multiply enormously. The disease which they cause is both painful and deadly. It is extremely rare, at least in this country.

179. Prevention of disease. — A sure preventive against any of these diseases is thorough cooking, for heat destroys all living germs. It has not been proved that salting and smoking meat kills the germs in it. There is no way of making musty or spoiled meat fit for food. Such meat never should be used.

SUMMARY

1. Milk is the most easily digested and most perfect of foods.
2. Hens' eggs contain an abundance of albumin and fat, but no starch or sugar. They are next to milk in ease of digestion.
3. Next in order come meats, including fish and shellfish.
4. Of meats, beef has high food value; mutton, fowl, pork, game, fish, and shellfish rank next, in the order named.
5. Animal food in general is easily and quickly digested and only about one twentieth remains undigested.
6. Meat should be fresh and from a healthy animal.

DEMONSTRATIONS

52. Show samples of fresh milk and skim milk. Curdling of milk can be shown by adding vinegar to milk and gently stirring it until the curd collects in a lump. Show that this is cheese. By setting some milk aside in a deep bottle, the amount of cream which rises can be shown. Butter can be made from some cream, but the process is uncertain, especially in winter.

53. Test some milk with a lactometer or a specific gravity bulb. In good milk it should sink to 1.030.

54. By cutting a hole in a piece of pasteboard and holding eggs in it in front of a lamp in a darkened room, contrast the bright pink of a fresh egg with the dull color of a stale egg, as is done in testing eggs in the market.

55. Show some fresh meat and some that is stale. Show some very tender and some very tough meat. Show that the toughness of meat is due to white strings of connective tissue.

REVIEW TOPICS

1. Give a definition of *food* and tell what five substances are used for food.
2. Show why an abundance of *water* is needed in food.

3. Show why *salt* is the only mineral which man adds to his food.
4. Give the four points which determine the digestibility and value of a food.
5. Show that *milk* is a perfect food and how it may be used to the best advantage, and how to avoid diseases which it may contain.
6. Show how to distinguish good milk from poor, and describe two methods for testing it.
7. Describe *cheese*.
8. Describe *butter* and its imitations.
9. Show how *eggs* are valuable as food and how they are deficient and how they had best be eaten.
10. Show how a good egg can be told from a spoiled one.
11. Show how *meat* is valuable as food and how it is deficient.
12. Compare beef tea with meat.
13. Compare fresh meat with meat which has been kept and with decayed meat.
14. Describe what diseases may be transmitted by meat, and how to avoid them.
15. Show how to select good meat in the market.
16. Show how fish and shellfish resemble meat.

CHAPTER XIII

VEGETABLE FOOD

180. Grain. — Food prepared from grain contains

Albumin	8 per cent	to	15 per cent.
Starch or sugar . . .	50	“	to 75 “
Fat	1	“	to 10 “
Mineral matter . . .	1	“	to 3 “

Some forms of its starch or sugar are digested with a considerable expense of time and energy, and there is always a considerable portion left over. From grain nearly all the starch and sugar of food is obtained.

181. Gluten. — The albumin of most grains is called *gluten*. It is easily dissolved in water and gives the sticky character to a mixture of flour and water. Its digestion requires an expenditure of more time and energy than the digestion of most forms of animal albumin, but its oxidation yields the same amount of energy. About one fifth is left undigested, whereas only one thirtieth of animal albumin is left.

The husks of the kernels of grain and the cellulose frameworks within are wholly indigestible. When milk is digested, there is little waste matter upon which the intestine can contract. A food like grain, which leaves much waste matter, furnishes something upon which the intestine can contract, and thus sweep the waste matters on and out of the body. For this reason vegetable food is of use aside from its nutritive value.

182. Fermentation of grain in the alimentary canal.—

Owing to its large amount of starch and sugar, and to its comparatively slow digestion, grain foods are liable to ferment. Fermentation will be the least apt to occur with a mixture of about equal parts of animal and vegetable food.

183. Bread.—Bread is the most common form of food made from grain. Usually some means are employed to make the bread porous and soft. *Yeast* is commonly added. Its germs grow and change the sugar of the flour to carbonic acid gas and alcohol. The gas, bubbling through the wet and sticky flour, puffs it up and fills it with small cavities, whose form the stiff and sticky gluten preserves. Corn meal has but little gluten to make it sticky, and so it will not preserve enough porous character to form a loaf of bread.

Instead of yeast, *baking powder* is often used to make bread or biscuit *light*. The powder develops carbonic acid gas, which bubbles through the dough. Nearly all baking powders are minerals, and their use in large quantity is undesirable.

Bread made from wheat flour requires less energy in its digestion than any other kind of vegetable food. Since some starch must be eaten, bread, in combination with milk, eggs, and meat, forms the best diet for everyday use. Rye flour makes nearly as good bread as wheat flour.

184. Other forms of grain food.—*Biscuit* is bread with a little fat added and baked in small lumps.

Cake is a mixture of flour, eggs, fat, and sugar. A large amount of fat or *shortening* tends to make it indigestible.

Pancakes are made of flour, corn meal, or buckwheat flour. If they are light and well cooked, they are of as much value as bread.

Cracked wheat and other preparations of wheat are often boiled in water, forming a mush or pudding. This has the composition and digestibility of bread.

Corn meal boiled, or made into pancakes or *corn bread*, is almost as easily digested as wheat flour. It contains a larger amount of fat than any other grain.

Oatmeal when boiled to a mush is a very popular article of diet. It requires more time and energy in its digestion than any other common grain food. It leaves a large amount of undigested residue, which sweeps out other waste matters as it is forced down the intestine.

Rice is poorer in albumin and richer in starch than any other grain. But when animal food is used in connection with it, there is no better combination of food, for it is the equal of flour in digestibility.

Barley is but little used as food by man. It contains little albumin but a large amount of starch.

185. Ways of preparing grain. — The finest grades of flour make bread which is digested with less cost of energy and with less residue than flour from the whole grain, while there is but little difference in the amount of albumin and starch which they contain. *Hot bread* is injurious only when it is moist and sticky so that it cannot be chewed to fine morsels. *Old bread* is more easily digested than *new* because it is harder and drier, and so can be chewed fine.

186. Beans and peas. — Beans and peas contain

Albumin	about 25 per cent.
Starch	“ 60 “
Fat	“ 2 “

Their albumin has much the same composition as the caseine of milk, and is called *legumin*. It requires a large expenditure of time and energy in its digestion. Both legumin and the starch are very liable to ferment in the intestine and produce gases. At least one fifth remains undigested. Beans and peas are good foods for an outdoor laborer who has a great deal of spare energy.

187. Potatoes. — Potatoes contain

Albumin	3 per cent.
Starch or sugar	22 “
Water	75 “

They are very poor in albumin, but rich in starch, so they go well with meat and eggs. Potatoes require a greater amount of time and energy in their digestion than bread and yield less heat and energy, and leave more undigested residue, and are more liable to ferment.

188. Difference between animal and vegetable food. — Animal and vegetable foods differ in several particulars :

First. Animal food requires less energy in its digestion. Animal, rather than vegetable, food is *light* diet.

Second. Because of its longer time of digestion, and of the larger amount remaining undigested, vegetable food is more liable to ferment in the stomach and intestine, so that in severe sickness vegetable food is usually entirely withheld.

Third. Vegetable food alone contains too much starch and sugar for the needs of the body. Fermentation is thus promoted. When absorbed, sugar is more readily oxidized than fat or albumin, and an excess of sugar takes oxygen from other parts of the body.

189. Special use of vegetable food. — While animal albumins and fats are more easily digested, and furnish a greater supply of heat and energy than the same kind of food of vegetable origin, it by no means follows that man should use them to the exclusion of vegetables. Their very ease and completeness of digestion may lead one to eat too much. Man's mouth and stomach combine the characteristics of herbivorous and carnivorous animals, and he will enjoy the best health when both classes of food are used. He must use some vegetable food for the sake of its starch or sugar.

190. Effect of cooking. — The distinctions between food just given were based upon experiments made upon healthy men, who ate slowly, and masticated food properly cooked. All vegetable food should be cooked so that it is a dry and crumbly mass which the digestive juices can easily pene-

trate. Thorough cooking renders all kinds of food more digestible. Raw starch is indigestible.

191. Green vegetables. — There are many kinds of vegetable food which supply little weight, heat, or energy to the body, yet are often eaten because of their agreeable taste. Beets, turnips, carrots, parsnips, pumpkins, and melons are poor in albumin. They contain some starch and sugar and much fibrous substance wholly indigestible. Their agreeable taste may increase the flow of the digestive fluids, and their bulk may excite the peristalsis of the intestine.

Tomatoes, cabbage, cauliflower, onions, asparagus, and all other green vegetables are still poorer in food material, and are especially liable to ferment in the intestine.

Green vegetables, such as cucumbers, which are eaten in an unripe state, are wholly indigestible. Thus they may pass through the intestine almost unchanged, or they may ferment and produce pain.

192. Iron in vegetables. — Green vegetables contain a considerable quantity of *iron-bearing* albumin or *nucleo-albumin*, while grain and animal food contain only a small quantity. This form of albumin is easily destroyed in the intestine if fermentation of food takes place. Under these circumstances green vegetables, by furnishing an abundance of this material, are a real food. Those should be chosen which do not readily ferment. Of them all, probably celery and spinach are best.

193. Fruit. — Fruits, such as apples, pears, plums, peaches, and berries, have little albumin which man can digest, but often have a large amount of sugar. Their chief use is to fill the intestine when a food is eaten which, like milk, leaves but little undigested matter to sweep along with the bile and other waste matters. But all fruits

are liable to ferment in the intestine. Grapes contain more albumin than almost any other fruit, while their sugar is the form produced by digestion. For these reasons they are easily digested, and are a real food. Bananas also contain much albumin and sugar. Green fruit is digested with difficulty and is very liable to injure the stomach. Over-ripe and decayed fruits often contain poisons which produce violent sickness. Only a small quantity of any fruit should be eaten at once.

194. Tart fruits. — Oranges, lemons, rhubarb, and such tart or sour articles of food are often said to be “cooling” to the blood. When the appetite fails, and the mouth is dry with a false thirst, their sourness excites the flow of the alkaline saliva, and so the mouth and tongue become moist, and the false thirst is relieved. In long voyages and expeditions, when fresh food cannot be obtained, they are of value in warding off scurvy. When eaten at meal times, the acid of sour fruits hinders the production of the gastric juice, and thus retards rather than aids digestion. In the stomach the acids unite with the mineral matters of the food, and then are absorbed into the blood. Their presence in the blood seems to have some effect on the nutrition and action of the cells, and on this account they are sometimes given as medicine. They seldom take part in building up the body, but are quickly thrown off by the kidneys. The popular idea of their cooling effect is derived mainly from the fact that they excite the flow of saliva, and thus render the mouth moist.

195. Nuts. — Nuts contain oil, but it is doubtful if much of it is emulsified and absorbed. They contain an abundance of albumin and starch, but their digestion usually requires more time and energy than the stomach of man is designed to furnish.

196. Canned food. — When food is heated so as to destroy its living germs, and then is at once sealed air-tight, it will neither decay nor sour, and when opened a long time afterwards it will be found to be as fresh and wholesome as when it was put into the can. Thus it is possible to carry fresh meat and vegetables on long voyages or to remote

and cold countries. When carefully prepared, canned food is as wholesome as food recently cooked. When opened it soon spoils.

197. Scurvy. — When men have been living for months upon bread and salt meat, without fresh food, there sometimes comes a disease called *scurvy*. The gums become sore, and the legs ache and turn "*black and blue*" as though they were bruised. Then fruit or green vegetables are of the highest value, probably because they furnish a good supply of *nucleo-albumin*, in which old bread and salt meat are apt to be deficient.

198. Seasonings. — Pepper, mustard, nutmegs, cloves, and all such sharp-tasting things are added to food simply for their taste. They are probably neither digested nor oxidized, and yield neither weight, nor heat, nor energy. They irritate and burn the stomach just as they do the mouth. Yet their pleasant taste may be of value in promoting the flow of the digestive juices.

199. Tea and coffee. — Tea and coffee are often supposed to supply food to the body. They belong to the class of substances which, acting through the nervous system, spur on the work of the cells of the body, especially of the brain. They supply no heat or energy for the extra exertion. Substances which excite the cells to action, without giving them material out of which to develop heat and energy, are *stimulants*. The active principle of tea and coffee is a stimulating substance called *caffeine* which spurs the cells of the body to do more work. They enable a person to do a larger amount of work *in an emergency*, and when the body is tired they rouse the digestive and assimilative organs to renewed activity, so that these quickly prepare a new supply of food. When they are used continually the body learns to rely upon their stimulation. Thus a habit of drinking them is formed which is not easily broken.

200. Tannin. — Coffee and tea also contain some *tannin*, which is a substance used in the manufacture of leather. It puckers and contracts albumin with which it comes in contact, and is liable to hinder digestion. Much of the bad effect of strong tea is due to its tannin.

201. Volatile oils. — Both tea and coffee also contain a considerable quantity of an oil, which gives the drinks their peculiar odors and flavors, but which evaporates quickly. It is mainly this oil which produces headache and sleeplessness and other troubles, when large quantities of tea or coffee are taken. Yet both drinks agree with the stomach better when the oil is retained in the drink.

202. Preparation of tea and coffee. — Both the caffeine and the oil of tea and coffee are easily dissolved by boiling water, but by long boiling the volatile oil is driven off in the vapor, and a large amount of tannin is extracted. Both these results are undesirable, and can be avoided by pouring boiling water over the tea and coffee, and then steeping it slowly for only a few minutes.

Coffee will be digested more easily if the milk which is added is boiled with the coffee. Better still would be to add no milk at all.

203. Adulteration of tea and coffee. — It is easy to add the leaves of other plants to tea leaves. Green teas are often colored with copper.

Coffee is adulterated with all kinds of roasted roots. A root called *chicory* is cultivated especially for this purpose.

204. Cocoa. — Cocoa contains a small quantity of a substance which stimulates like caffeine. It also contains a considerable quantity of albumin and fat, both of which will dissolve in water. Thus it is more of a food than tea or coffee, and its use is less likely to cause indigestion. Chocolate is a preparation of cocoa.

205. Use of tea and coffee. — Tea and coffee are not necessities, and men would be just as healthy without their use. They have a reputation of retarding waste

of the body, but this view is not founded upon definite experiments. The nervous system of children is easily impressed by tea and coffee, and their bodies cannot stand the stimulation and extra work which these substances induce. When long and fatiguing work *must* be done or great exposure endured, then tea and coffee are valuable stimulants.

206. Adaptation of man's stomach to certain foods.— Green vegetables, fruit, and grass contain the proper quantities of food elements to support man's life, but man cannot digest them readily. Lower animals eat the food and expend their digestive energies on it; finally, when man eats it in the form of milk, eggs, or meat, it needs but little further digestion.

SUMMARY

1. Grain is the main source of vegetable food.
2. Grain albumin, or gluten, is digested at more expense of time and energy than the albumin of animal food.
3. Grain food contains much starch, and must be eaten to supply this element.
4. Grain food is more liable to ferment than animal food.
5. Bread is the form of grain most available for digestion.
6. Boiled preparations of grain contain the same food elements as bread.
7. The most valuable of the grains which are usually eaten boiled are rice, cracked wheat, corn meal, and oatmeal.
8. Cake and biscuit may be considered as forms of bread.
9. Beans and peas are rich in albumin and starch, but require a great deal of energy in their digestion.
10. Potatoes are poor in albumin but rich in starch. Their digestion requires much energy.

11. Animal food in general fulfills the points of digestibility better than vegetable food.
12. Green vegetables and fruit are of value because their taste may excite the flow of digestive fluids; the large residue left after their digestion may sweep waste matters down the intestine; and they may form a supply of nucleo-albumin when the supply in ordinary food is deficient.
13. Green vegetables and fruit should be eaten a little at a time, because of their great liability to undergo fermentation.
14. Tea, coffee, and cocoa spur the cells on to renewed activity when the body is tired or weakened.

DEMONSTRATIONS

56. Grain albumin, or gluten, can be separated by mixing a small mass of dough of wheat flour and gently washing out the starch by kneading it under water. The gluten will be left as a stringy, sticky mass. The starch in grain can be shown by the iodine test (page 31).

57. Show samples of bread, both light and heavy, sweet and sour, well-baked and under-done, new and stale, and hot and cold. Show that the difference between the last three pairs depends upon the one kind forming a pasty mass when wet or chewed, while the other kind may be broken into fine particles.

58. Show samples of properly cooked and of improperly cooked rice, oatmeal, etc.

REVIEW TOPICS

1. Give the composition of *grain*.
2. Describe the albumin of grain.
3. Describe *bread* and the process of its manufacture.
4. Describe foods which are like bread.
5. Describe the various kinds of grain which are eaten when boiled to a mush.

6. Give the difference of digestibility between bread made from unbolted and fine flour; between hot and cold bread; between new and old bread.
7. Give a reason why grain food should not be sweetened.
8. Describe *beans* and *peas*.
9. Describe *potatoes*.
10. State why the method of cooking and the manner of eating make a great difference in the value of vegetable foods.
11. Give the main points of difference between animal and vegetable foods.
12. Name the food elements in green vegetables and in fruits.
13. Give the important uses of green vegetables and fruits.
14. Tell how green vegetables and fruits should be eaten.
15. Show that man's stomach is adapted to certain kinds of food only, and tell how all kinds of food may ultimately become adapted to his use.
16. Give the active principles of tea, coffee, and cocoa, and the effects of each upon the body.
17. Name the food elements in milk; in eggs; in meat; in grain; in potatoes; in beans.
18. Give the organ in which each of the following foods are acted upon, the digestive fluids which act upon it, and the chemical change produced by each fluid: milk, eggs, meat, bread, butter, grain food, potatoes, beans.

CHAPTER XIV

QUANTITY OF FOOD REQUIRED

207. Amount of food elements required. — Although oxidation is continually going on in each cell of the body, only a small part of the albumin eaten is required in their reconstruction; the remainder and all the sugar and fat are oxidized without ever becoming a part of the living cells of the body. The amount of heat produced is measured in Calories, one Calorie being the amount of heat required to raise the temperature of 1 kilogram of water 1° C.

In order to repair the waste caused by the oxidation of the cells, and to supply the requisite amount of heat and energy, the average man must assimilate daily about 13½ ounces of food, with a heat value of about 2250 Calories, as follows:—

	CALORIES PER OZ.	TOTAL CALORIES.
Albumin 4½ ounces	132	554
Fat 4 "	285	1140
Sugar (or starch) 5 "	110	550

208. Amount of oxygen required. — The amount of oxygen needed to oxidize this food is found from pages 34, 35, to be about twenty-four ounces. The average amount of oxygen taken in daily by the lungs is twenty-four ounces. When more food is eaten than this amount of oxygen can oxidize, some of the albumin is changed to fat, which increases the weight of the body.

Anything which causes the lungs to take in more oxygen

will enable the body to oxidize more food. So the laborer breathing deeply of fresh air is less troubled with the bad effects of over-eating than a clerk in an office.

209. Oxidation of an excess of sugar. — Sugar is more rapidly oxidized than other food, and when too large a proportion of starch or sugar is eaten the other food is incompletely oxidized, and sickness is the result. A greater proportion of starch is required when more heat and energy are needed, as in physical labor.

210. Selection of diet. — To supply the proper elements, a variety of food may be selected, of which the following diet for twenty-four hours is a typical example.

	OZ. OF ALBUMIN.	OZ. OF FAT.	OZ. OF SUGAR.
7 ounces of bread contains . . .	0.7	0	4.2
3.5 " eggs (2) " . . .	0.5	0.5	0
14 " meat " . . .	2.5	2	0
24 " milk (1½ pt.) " . . .	0.9	1	1.2
1.5 " butter " . . .	0	1.5	0
Total	4.6	5	5.4

Allowing for the amount usually left undigested, there would remain about the proper amount of each kind of food element. This food contains more than enough mineral matter to supply all the needs of the body.

211. Choice of food. — The price of food has little to do with its nourishing qualities. Fine taste, good appearance, and rarity are usually what make foods costly. The cheaper kinds are quite as nourishing as the more fashionable, and will taste as good if they are well cooked. About three fourths of a laborer's wages are spent for food. Cheaper meats and fish, with less sugar and desserts, will

furnish him a better diet, and at less cost. It is as bad economy for a poor man to buy the *best* of food as it is for him to buy silk and broadcloth clothing. Scraps and food left over from the table are as good quality as ever, and should be saved for the next meal.

212. Amount at a meal.— Rules prescribing the amount of food to be eaten at once cannot be given, any more than fixed rules regulating the amount of wood to be added to the fire in a cooking stove. Hunger and taste are reliable guides when plain food is eaten slowly.

213. Too much food.— In some persons the stomach cannot digest and absorb food so fast as the lungs can furnish oxygen for its oxidation. While these persons eat heartily they generally remain thin, for, instead of accumulating food, they use it up in developing energy for active work. They are apt to overwork their stomachs and to suffer from indigestion. They need nutritious and easily digested food. Other persons can digest food faster than the lungs can supply oxygen for its oxidation. These persons eat little, but, since the slow oxidation allows food to accumulate, they are apt to be fat and lazy and to suffer from lung troubles. By allowing their strong stomachs to act upon the less easily digested foods their appetites will probably be satisfied, and still not enough food will be digested and absorbed to overtax their lungs.

214. Starvation.— When man is deprived of all food, life is supported by the oxidation of his own flesh as long as it lasts. In from six to ten days a man will lose two fifths of his original weight, and then death occurs. When water is given, life will last for a much longer time.

215. Brain food.— Brain workers require the same kind of food as the laborer. In its action the brain uses heat and energy, the same as any other part of the body. Fish is no more a brain food than beef-steak. Phosphates, which are popularly supposed to nourish the brain, are arrested at the liver; but they stimulate the liver to greater activity, so that food is more perfectly assimilated, and thus greater strength is given to the brain cells, as well as to the rest of the body. Phosphorus is found in most foods in greater quantities than the body needs.

SUMMARY

1. About four ounces of each of the food elements—albumin, fat, and sugar—must be eaten daily.
2. To oxidize this amount of food requires about twenty-four ounces of oxygen, which is about the amount breathed in.
3. A diet of bread, eggs, meat, milk, and butter will furnish the best food elements.
4. If too much sugar or starch is eaten, the albumin and fat are not fully oxidized.
5. If too much food is eaten, all the oxygen is used up, and there is none left for an extra exertion.
6. If little or no food is eaten, not enough heat and energy are produced to keep the body alive.

DEMONSTRATIONS

59. Weigh out the different amounts of bread, eggs, meat, milk, and butter which are required daily. Also measure out a quart of water. This will show the class the amounts of food required daily.

60. Weigh out the required quantities of albumin, fat, and sugar. Albumin may be represented by gelatine or glue.

REVIEW TOPICS

1. Give the amount of albumin, fat, and sugar required daily.
2. Give the amount of oxygen required to oxidize the food.
3. Give the results of oxidizing an excess of sugar.
4. Give the amounts of bread, meat, etc., required daily to furnish the body with the proper amount of albumin, fat, and sugar.
5. Give the best times for eating.
6. Give the effects of eating too much food; of too little.

CHAPTER XV

DRINKING WATER

216. Pure water. — Water is the only food which man habitually takes without its previous preparation. Water is the same from whatever source, but substances dissolved in the water change its appearance. Carbonic acid gas, oxygen, and air are dissolved in all ordinary water, and in it float particles of dust and often a few harmless living germs. Such water is clear and colorless. It has a slight taste, due to the dissolved air. When the air is expelled by boiling, the water is insipid and almost tasteless.

217. Hard and soft water. — Water also contains a variable amount of mineral matter, especially lime, soda, and potash. Water containing lime makes the fingers feel slightly rough and puckered. The lime combines with soap, forming a scum which will not dissolve. Water containing lime is said to be *hard*, while water with little or no lime is *soft*. Although some gases and minerals are dissolved in all water, they are harmless and do not make it impure, but rather they give it a more pleasant taste. When very hard water is boiled, some of the lime is deposited on the sides of the kettle, and the water is improved but not made soft.

218. Mineral waters. — When much mineral matter is present the water is called *mineral water*. The principal minerals thus found in water are salt, lime, soda, potash, iron, and sulphur. These waters form springs in various parts of the country, and have borne a great

reputation as healing agents even among the Indians. Enormous quantities are sold for drinking and medicinal purposes. Some contain one or two ounces of mineral substance to each gallon of water. Some springs contain almost pure salt, and furnish the greater part of the table salt in common use.

Water in city houses often contains iron rust from the pipes through which it passes, but the rust is not harmful to health. The water may dissolve some poisonous lead if it stands in lead pipes, but if it is allowed to run for a moment, the lead will be washed out.

219. Impure water. — When water becomes impure, the water itself does not change its nature or become poisonous. Its impurities are substances which either float in the water or are dissolved in it. They consist largely of harmless clay and mud which are carried by running water, but soon settle to the bottom in quiet water. Other impurities are vegetable matters, such as the remains of leaves and wood, but these too are usually harmless. Streams and ponds which usually furnish wholesome water are often cloudy and muddy after a rain, but become clear and wholesome again after the water becomes quiet.

220. Decayed matters and disease germs. — The principal substances which make water dangerous to health are disease germs. If water contains no disease germs, it will seldom cause sickness, even though it be muddy and discolored and have a bad taste and odor. The germs are not produced by the water, or the soil, or the air, but come only from diseased men or animals. In desert and uninhabited places all the water is usually wholesome, for no sick persons are there to produce disease germs; but wherever waste matters are given off from the bodies of sick men or animals, there germs of disease are almost sure to be found. For this reason water which contains even a trace of decaying animal substances is dangerous to health, for it is likely to contain disease germs. The germs may remain alive after

the substances themselves have become so far decayed that they dissolve like salt and leave the water clear, and odorless, and tasteless.

221. Source of impurities.—The usual way in which disease germs reach drinking water is by means of sewage, and slops, and barnyard drainage. There is hardly a house in which, during a year's time, some sick person does not give off disease germs. The germs are found in all the waste matters which come from the sick person's body and in the dish water and bath slops from the house. The germs may live and grow in the slops after they have been emptied, and may find their way into a well, and thus may reach any one who drinks the water. They may be washed into a river and cause sickness among those who use its water or ice. This is the usual way in which typhoid fever is spread. The number of typhoid fever cases in a town is often taken as an indication of the purity of the water supply. By keeping the water supply pure this disease may be almost suppressed. It might be entirely suppressed by disposing of all sewage in a harmless way (see pp. 251-253).

222. Purification by oxidation in the soil.—The ground has the power of oxidizing decayed vegetable and animal matter so that only the mineral parts remain. Slops from the house are thus oxidized, if the ground is not soaked through with them. But when the quantity is great, some may work their way through the ground for a considerable distance and finally enter a well.

223. Purification by filtration.—Clean sand has the power to screen out particles carried by the water. Screening out substances from water by passing it through a powdered substance is called *filtration*. As the slops slowly soak through the soil, their solid parts are filtered out in the first few inches of the top soil, and if the quantity is not too great, are soon oxidized. Soils differ in their ability to filter. Clean sand is the best; clay is the poorest. It is almost impossible to

saturate sandy soil about a single house so that decaying matter can reach the wells; but in villages and cities the soil is so completely soaked with sewage that the well water of these places is impure, and should not be used.

224. Purification by running water. — The third way in which water is purified is by the action of the air and sun upon running water. Sewage from the towns is often conducted into rivers, and the sunlight and agitation of the waters cause the waste matters and germs to be oxidized. Yet many of the germs may be carried far down the stream. Thus few rivers are safe sources of drinking water, unless the water is first purified (p. 409).

225. Purification by boiling. — It is dangerous to use impure water for washing, for germs may remain upon the things washed. Typhoid fever has been spread by milk cans which were washed in water from a polluted well. A ready safeguard against the greater dangers of impure water is boiling, which destroys the germs of disease.

SUMMARY

1. Water containing lime is *hard*, but without lime it is *soft*. Lime seldom injures water for drinking purposes.
2. When other minerals, such as sulphur, iron, soda, or potash, are present, water is called *mineral* water. Such water is used as medicine.
3. Air dissolved in water gives it a pleasant taste.
4. Water containing decaying matter is unfit for use.
5. The greatest danger from impure water lies in the germs of disease which it may contain.
6. Boiling the water is an easy safeguard against impure water.
7. The soil purifies water by oxidizing and filtering the impurities. Running water is generally pure.

DEMONSTRATIONS

61. Show that all water contains mineral matter by evaporating a few drops of pure spring water upon a piece of clean glass. A little white spot will be left by each drop. Boil some water and notice the absence of taste. Cool it and shake it in a can, and notice its natural taste again. Set aside some pure water containing a few bread crumbs or a shred of meat, and notice the unpleasant odor of decay developed in a few days.

62. A rough test for the purity of water is to stir in a little pure sugar and set it aside. If it contains any organic matter, it will turn yellowish in a few days, but otherwise it will remain colorless. Collect some rain water from a dirty building, or mud-puddle water, or water from a barnyard well, and note the color and the odor. After keeping it a few days, note the deepened color and worse odors, showing decay within the water.

63. Doubtless the class will ask to be shown "animalculæ" in water. Water has to be almost turbid and putrid before living beings are present in sufficient numbers to be easily detected with a microscope. If a drop of very stagnant water is examined under the microscope with a power of 100 to 400 diameters, many strange beings will be seen moving about. Place a little hay in a bottle of water and examine a drop of the water every day, and notice the changing forms of the living beings as one kind dies and another is produced.

REVIEW TOPICS

1. Describe the appearance and taste of pure water.
2. State what substances are found in all water; what in mineral water; and the difference between *hard* and *soft* water.
3. State the most dangerous impurity in water.
4. Give three ways in which nature purifies water.
5. Show how to avoid pollution of a well.
6. Show how to render impure water safe for use.

CHAPTER XVI

NARCOTICS

226. What man eats besides food. — Besides eating food and harmless things which please the taste, man also eats a variety of dangerous substances, both for pleasure and to overcome some real or fancied weakness of the body. The physician prescribes them to overcome diseases of the cells, but thoughtless and ignorant people use them on their own responsibility, and suffer great harm thereby. They may be divided into *narcotics*, *drugs*, and *poisons*.

227. Narcotics. — There is a class of drugs which benumb the sense of pain and fatigue and lessen the action and strength of the cells of the body. These drugs are called *narcotics*. They all are powerful poisons. They lessen the sense of effort and of fatigue, and are often supposed to be stimulants. A peculiarity common to all is, that when their benumbing effects have passed off, the real weakness of the body becomes doubly apparent, and there is an overwhelming desire for more of the drug to benumb the increased weakness caused by the first dose. Thus enslaving habits are formed.

228. Alcohol as a narcotic. — Alcohol should be classed as a narcotic drug. It really belongs to the class of stimulants as well. A small amount acts as a stimulant; but a large amount overwhelms the body and produces an insensibility to pain and fatigue, a dullness of mind, and a deep sleep. The use of alcohol tends to become a fixed habit, as is the case with other narcotics.

229. Alcoholic poisoning. — Besides slow poisoning, alcohol can produce severe poisonous effects at once. A man "dead drunk" is poisoned by alcohol, and is in danger of his life. In treating him, vomiting should be induced as soon as possible. He should be rubbed to keep up the circulation, and stimulated with hot coffee. Keep his body, and especially his feet, warm.

230. Tobacco and nicotine. — The essential part of tobacco is a strong narcotic poison called *nicotine*. Pure nicotine is a clear and colorless liquid. It can be turned to vapor, and is found in the smoke when the tobacco is burned. It is a powerful poison, producing stomach sickness and great weakness of all the cells of the body, especially of the heart. Two or three drops will kill a man.

231. Effects of its continuous use. — When used continuously, the body becomes somewhat accustomed to nicotine, so that it does not produce so great a feeling of sickness. Then instead of producing a feeling of weakness, it acts more to benumb the cells and to quiet the body. This is really the first stage of poisoning, although it seems like a stimulation. If a little more tobacco than usual is used, the benumbed and pleasant feeling changes to one of sickness, as though it were being used for the first time. It always continues to have bad effects upon the muscles, heart, lungs, eyes, and brain. Tobacco is especially injurious to young persons, hindering their growth and lessening their strength.

232. How tobacco is used. — Tobacco is used in smoking, in chewing, and in snuffing it up the nose.

233. Smoking. — Tobacco is smoked in a pipe or by lighting the end of a roll called a *cigar*. Some of the nicotine is turned to vapor and enters the mouth, where it may be absorbed. Some of the nicotine is half burned,

and forms a substance called *pyridine*, which is even more poisonous than nicotine. In a cigar the burning is more complete, and less pyridine is formed. *Cigarettes* are small cigars made of shredded tobacco. They are cheap and may be quickly smoked, and are less liable to produce immediate sickness than a cigar. So the young are especially apt to use them. But they are commonly used to excess, and so make up in quantity of poison what they lack in quality.

234. Chewing. — Chewing tobacco is the most harmful form of its use, for all the nicotine is taken into the mouth. Few people can chew tobacco without spitting out the saliva which contains the nicotine. The continuous spitting which is necessary to get rid of the saliva makes this form of using tobacco offensive to everybody near the chewer. This reason alone should deter any one from the practice of chewing tobacco.

235. Snuff. — Snuff is powdered tobacco. A hundred years ago it was fashionable for women, as well as men, to use snuff. Now a snuffbox is a rare curiosity.

236. Adulteration of tobacco. — The nicotine from stalks and remnants is extracted by boiling, and the liquor is used to saturate poor tobacco and the leaves of other plants.

Chewing tobacco owes much of its taste to rum, molasses, licorice, and other things with which it is flavored.

Most *cigarettes* are flavored with drugs which color the fingers of the smokers. Cigarettes are harmful enough at best, but the harm is far greater when they contain opium. Probably a great part of the craving which cigarettes induce is caused by the opium.

237. Tobacco habit. — Like all other narcotics, when it is used for a short time tobacco produces a persistent craving. Men laugh at the idea of being slaves to such a small thing as smoking or chewing, and yet when the habit

is interrupted, there follows a peculiar unsatisfied and nervous feeling which few men are able to overcome.

Alcohol and tobacco often go hand in hand. Tobacco produces a dry state of the mouth which demands drink, while alcohol causes a nervous excitement which the benumbing tobacco tends to overcome. Most users of alcohol smoke. The only way to break off the habit of using tobacco is to do so by resolute efforts of the will. So-called cures of the habit are of no value, for they cannot give a man a strong will. On the other hand, they may induce sickness.

238. Tobacco poisoning. — Severe tobacco poisoning is rare; for when swallowed or inhaled, it produces vomiting, which expels the poison. When applied to the skin in the form of a poultice, as is sometimes done, enough may be absorbed to produce great weakness, for then the stomach cannot expel it. The principal sign of poisoning is extreme weakness of the muscles and heart.

To treat it, strong coffee should be given, and the patient should be kept perfectly at rest.

239. Opium. — Opium is a narcotic drug which is used to benumb the feelings of fatigue and care. A little of the drug acts partly as a real stimulant, causing the cells to act more vigorously and clearly. At the same time its benumbing action is beginning, and only a little more is needed to produce a drowsy feeling or a deep sleep. Just as it causes the brain cells to cease acting in sleep, so also it lessens the action of all the other cells, and especially of those of the alimentary canal. The disturbance in the action of the intestine sets up digestive trouble, which extends rapidly to the liver. Then the nutrition of the whole body is lowered. No habit is more enslaving or more harmful in its effects.

240. Cure of the opium habit. — The only cure for the opium habit, and yet a safe and sure one, is to keep the

patient entirely away from the drug for a few weeks, confining him if necessary. After a short time the craving disappears and the patient recovers his health.

241. Opium poisoning. — A lump of opium the size of a small pea, and weighing about two grains, is enough to put a man into a deep sleep. Twice that amount may cause death. When a person takes an overdose he falls into a deep sleep, from which he can be awakened only with difficulty. He breathes very slowly, and distends the lungs very slightly. The pupils of his eyes contract to small points. These three signs nearly always mean opium poisoning. They should be remembered, for this is the most common form of poisoning.

242. Treatment of opium poisoning. — *First.* Keep the patient awake by such vigorous measures as slapping his face, shaking his body, and compelling him to walk.

Second. Induce vomiting. A tablespoonful of mustard in water should be given at once if the person can swallow. Tickling the throat with the finger or a feather will generally cause vomiting.

Third. Stimulate the patient with strong, hot coffee. Carry out these measures slowly and deliberately.

243. Forms of opium. — Opium is the dried juice of a kind of poppy plant growing in Southern Asia. *Laudanum* is opium dissolved in ten parts of alcohol. *Paregoric* is a more dilute solution of opium. A teaspoonful of it contains one quarter of a grain of opium. About one tenth of opium is a white substance called *morphine*. One quarter of a grain of morphine will cause a deep sleep and contracted pupils like a large dose of opium.

244. Use of opium. — Opium is used to quiet pain, produce sleep, and to quiet the intestine.

Paregoric is sometimes used to quiet babies when they cry. It produces indigestion and leaves the child worse

than before. "Soothing sirups" are nearly always some preparation of opium.

245. Chloral. — Chloral is a colorless solid, having a peppery odor and taste. About twenty grains will produce sleep, but an overdose may produce death. It injures the digestive organs and weakens the whole body. It is a narcotic and a poison.

246. Chloral poisoning. — In treating a case of chloral poisoning the patient should be kept awake by walking him about, or even by slapping him. Give a tablespoonful of mustard in water to make him vomit. Then give strong coffee to stimulate him.

247. Cocaine. — Cocaine is a drug which, when injected under the skin or applied to a mucous membrane, takes away the sense of feeling of the part. A grain of it will render a large area so completely insensitive for half an hour that large operations can be performed without sense of pain. It may cause excitement like the beginning of a state of drunkenness; sometimes it produces great weakness of the heart and death.

The excitement caused by the drug is pleasant, and persons can acquire a slavish habit of its use. It rapidly disturbs digestion and nutrition, and soon causes death. It is one of the most rapid and terrible forms of habitual drug-taking.

248. Hasheesh. — Hasheesh is the juice of the Indian hemp plant, and is sold as a medicine under the name of *cannabis indica*. In Southern Asia it is extensively used as a narcotic. It produces a happy delirium, in which a person sees most beautiful persons and figures. The state is really a temporary insanity, in which one is liable to injure others. The word "assassin" means one under the influence of hasheesh.

249. Chloroform.—Chloroform is a sweet-smelling liquid which, when breathed into the lungs, causes a deep sleep. It is used to produce insensibility during surgical operations. Its use requires extreme care, for it can easily result in death. No one should even smell a bottle containing it, for two or three breaths of it may render a person insensible.

SUMMARY

1. Narcotics lessen the sense of fatigue and pain and produce sleep, but weaken the body and may cause death. Their use may become an uncontrollable habit.
2. Alcohol is a kind of narcotic.
3. Tobacco contains the narcotic *nicotine*. A little nicotine quiets the cells, while more causes weakness, and stomach sickness which may result in death.
4. Tobacco used in any form produces poisonous effects.
5. The tobacco habit tends to the use of strong drink.
6. Opium quiets the cells of the body, lessens the sense of pain, and produces sleep. A little causes a feeling of exhilaration, while a few grains may cause death.
7. The opium habit deranges digestion and finally causes death.
8. In poisoning by opium there are a deep sleep and contracted pupils and slow breathing.
9. The poisoned person should be kept awake, made to vomit, and stimulated by coffee.
10. Laudanum, paregoric, and soothing sirups are all forms of opium.
11. Chloral produces sleep. A large dose may cause death. Treat its poisoning like opium poisoning.
12. Chloroform, when inhaled, produces insensibility.

REVIEW TOPICS

1. Define and describe *narcotics* and show how their use may become a habit.
2. Show that alcohol is a narcotic, and give the signs and treatment of its poisonous effects.
3. Describe the poison of tobacco and its effects.
4. Describe the harm resulting from the use of the several forms of tobacco.
5. Show the fraud and harm of adulterating tobacco.
6. Show that the use of tobacco and alcohol naturally go together.
7. Describe the effects of *opium* and the opium habit.
8. Describe the signs and treatment of opium poisoning.
9. Name some common forms of opium and give their uses.
10. Describe *chloral*, and give the signs and treatment of poisoning by it.
11. Describe *cocaine*, its use in surgery, and its poisonous effects.
12. Describe *hasheesh*.
13. Describe *chloroform* and the danger of its use.

CHAPTER XVII

DRUGS AND POISONS

250. Nature of disease. — Disease is due to some derangement of the action of the cells of the body. The derangement is almost always produced by overwork of some kind, for the cells are able to protect the body against all ordinary causes of disease. Few people who are exposed to epidemic diseases take them, because the cells are able to destroy the germs as fast as they enter the body. If men would eat, breathe, and in all things live as physiology and hygiene show that nature intended them to live, the cells would be strong enough to resist almost any disease. The diseases caused by germs are discussed on pages 382–432; only those produced by drugs and poisons are discussed in this chapter.

251. Action of drugs. — Each drug has a special influence upon certain cells of the body, and is able either to stimulate or to restrain their action. Under the influence of the proper drug, each deranged cell takes in nourishment and performs its duties more perfectly, and soon overcomes the sickness. Thus the cells themselves, and not the drug, cure the disease.

252. Action of a few common drugs. — When the liver is deranged, *calomel* or *podophyllin* will usually stimulate it to action. In stomach indigestion *muratic acid* and *pepsin* supply the missing digestive agents. When the heart is weak, *digitalis* or *strychnine* cause it to act more strongly, while if it is excited, *aconite* will quiet it. A fever is often lowered by *aconite* or *phenacetine*. When there is pain, *opium* will generally relieve it. When the brain is excited and the person is

nervous or delirious, *chloral* or *bromide of potash* will quiet the cells. These are a few examples of the actions of drugs which physicians prescribe.

253. Quack medicines. — Drugs should never be given except by a physician. The country is flooded with medicines advertised to cure various diseases. People who take them generally get well, but they forget that the cells of the body themselves tend to overcome all diseases, and that in all probability they had no disease at all, but were only feeling bad because of improper eating, or of overwork.

254. Poisons. — All narcotics and drugs are poisons and cause sickness or death when taken in overdoses. The signs of poisoning are much alike in all cases. A person previously well suddenly feels very sick and weak, or becomes unconscious. Vomiting often occurs, and pain is often present.

255. Treatment of poisoning. — The first thing to do whenever a poison is swallowed is to empty the stomach as quickly as possible. Almost anybody can be made to vomit by tickling the throat with a finger, or with a feather passed through the nose if the mouth cannot be opened. A tablespoonful of mustard in a cup of warm water will generally cause vomiting and is always safe. A teaspoonful of alum in water will act in the same way. Water or soft food of any kind should then be swallowed and vomiting continued, so as to remove all traces of the poison.

The second thing is to give castor oil or salts, so as to remove any poison which may have entered the intestine.

The third thing is to give something, called an *antidote*, which will destroy the poison in the body.

The fourth thing is to give a *stimulant*, for the person will be very weak. Strong coffee should be given by the cupful, without sugar or milk.

256. Poisoning by acids or alkalies. — If the lips and mouth are covered with a white film or are raw, some

acid or alkali has probably been swallowed. If it is an alkali, a drink of weak *vinegar* should be given at once as an antidote. If it is an acid, soda, soapsuds, or limewater should be given as an antidote.

Also give water, or flour and water, or the white of an egg, or milk, so as to dilute the substance as soon as possible.

257. Carbolic acid. — When swallowed, pure carbolic acid produces great weakness and rapid death. In small doses, or even applied to the skin in surgical dressings, it may produce headache and weakness, which may result in death.

In treating its poisonous effects, a stomach pump will generally have to be used to remove the poison, because the stomach will be paralyzed by the burning to which it is subjected. The antidote is *Epsom salts*.

258. Narcotic poisoning. — If the person poisoned is sleepy, it shows that a narcotic like opium or chloral has been taken. Care should be taken not to mistake a fainting spell for the drowsiness of poisoning. In faintness, the face is of a deathly pale color, and no pulse can be felt, and breathing ceases, while in drowsiness the face is of a natural or even deeper red color, the pulse can be felt, and breathing will continue.

259. Strychnine poisoning. — Strychnine produces violent convulsions, like lockjaw, within half an hour after it has been taken. Vomiting should be induced at once. Chloral and bromide of potash are its antidotes, and should be given as soon as possible, to quiet the convulsions. In an emergency tobacco may be used.

260. Arsenic and other metals. — Rat poison and Paris green contain arsenic. Arsenic is a metal, and its poisoning is much like poisoning by *mercury, lead, copper, silver,*

or *antimony*. *Sugar of lead* and *white lead* paint are the common forms of lead which poison the body. Copper is seldom dangerous. Some forms of *silver* are very poisonous.

Antimony is poisonous in the form of *tartar emetic* and *wine of antimony*, both of which are used in treating colds.

All forms of metallic poisoning are much alike. Vomiting usually comes on within half an hour, followed by great weakness, cramps in the abdomen, and burning thirst. If vomiting has not freely occurred, it should be induced by tickling the throat or by giving mustard in water.

Afterwards the white of eggs, flour paste, or milk should be given as an antidote. The albumin of these substances forms a chemical union with the metal, producing a harmless compound which should be vomited and more of the antidote given.

The special antidote for *arsenic* is *oxide of iron*. The settlings which form in a mixture of tincture of iron and baking soda may be used in an emergency. The special antidote for *lead* is *Epsom salts*; for *silver*, *common salt*; and for *antimony*, *tannin*, which is found in a strong tea made of almost any bark.

261. Phosphorus.—Phosphorus poisoning may occur from sucking the ends of matches. It produces vomiting and violent cramps in the abdomen for two or three days, and then jaundice appears, with delirium and death. It resembles a slow poisoning by a metal.

Phosphorus poisoning is treated by giving something to cause vomiting and to expel the poison from the intestine. Always avoid castor oil or other fat, for phosphorus is dissolved by fat. A small pinch of sulphate of copper (blue vitriol) given every few minutes will destroy the poison and also cause vomiting.

262. Aconite.—Aconite produces extreme weakness of the whole body. A tingling in the throat is the only distinguishing sign of the poison.

A poisoned person should be kept absolutely quiet, and strong coffee should be given as a stimulant.

263. Belladonna. — Belladonna, or its active principle, *atropine*, is used to enlarge the pupil in examinations of the eye. In overdoses it produces redness of the face, dryness of the throat, enlargement of the pupil of the eye, delirium, and great weakness. The enlarged pupil is its distinguishing sign. Its treatment consists in giving an emetic, stimulating by coffee, and giving tannin or strong bark tea.

264. Mushroom poisoning. — Poisonous mushrooms produce violent cramps in the abdomen, with vomiting and great weakness. One form produces symptoms within an hour or two, and is seldom fatal, for the poison is thrown off. The other, and by far the more dangerous, form of poisoning does not come on for ten or twelve hours, or until the poison has entered the intestine. In poisoning by mushrooms, vomiting should be induced, and castor oil given to remove the poison from the intestine. Strong coffee should be given as a stimulant.

265. Decayed food. — All forms of decayed food, especially fish, eels, and crabs, may produce vomiting, cramps, and weakness, like mushroom poisoning. The symptoms usually come on within six hours after eating, and are seldom fatal. The treatment is to empty the stomach and intestine.

266. Alkaloids. — The active principles of many vegetable drugs can be separated from the crude drugs. They are called *alkaloids*. Nicotine, morphine, strychnine, atropine, and quinine are alkaloids. Over one hundred in all are known. A single grain of almost any alkaloid except quinine can produce violent poisoning.

267. Leucomaines. — As a result of the imperfect oxidation of albumin within the body, compounds resembling

alkaloids are formed. They are called *leucomaines*. They circulate in the blood and produce headaches, drowsiness, and other mild forms of poisoning which may become severe and produce death when, as in Bright's disease, the kidneys and skin do not remove the poisons. At least sixteen leucomaines are known.

268. Ptomaines. — As a result of decay and other changes after death, another set of poisons like alkaloids and leucomaines are produced. They are called *ptomaines*. They cause most of the symptoms produced by eating decayed meat. A special kind of the poison, called *tyrotoxicon*, sometimes forms in milk and ice cream which has been kept for some time. Ptomaines and leucomaines can always be found in the bodies of dead persons.

269. Hypodermic injections. — When injected beneath the skin by means of a hypodermic needle, drugs and poisons reach the blood at once and produce much more powerful and rapid results than when absorbed from the stomach. Alkaloids are well fitted for this use.

270. Snake bites. — In the upper jaw of a poisonous snake is a sharp, hollow tooth, which is the outlet for a bag of poison. When the snake bites, the pressure of the flesh against the bag forces some poison through the tooth, which thus acts as a hypodermic needle. The poison is a kind of leucomaine. It produces pain and swelling at the point of injection, great weakness of the whole body, and sometimes death.

The treatment of snake bites must be prompt. A handkerchief should be tied very tightly round the limb, above the wound, so as to prevent the poison from reaching the whole body. Then the wound should be sucked for some time, so as to remove as much as possible of the poison. No harm can come to the person who sucks the wound if the blood is spit out at once. If bleeding does

not take place freely, the wound should be cut open. Active stimulation with such substances as strong coffee or ammonia is also necessary.

271. Insect stings and bites. — Bees, wasps, and hornets possess a hollow sting through which the insect injects poison into the flesh. This poison produces swelling and pain, and if there are a great number of stings, there will also be a considerable weakness of the whole body. Usually the swelling begins to decrease within an hour. To allay the smarting, a lump of cold mud is an effective remedy. Carbolic acid in water sopped on with a cloth is also good. If the insect has left its sting in the flesh, it should be removed by pressing over the sting with the open end of a watch key, or by picking it out with the point of a sharp knife.

The bites of mosquitoes and of flies produce swelling and pain or itching in some people. Ammonia water or carbolic acid in water usually gives relief.

SUMMARY

1. Disease is a derangement in the action of some of the cells of the body. Drugs either stimulate or retard the action of the cells.
2. All narcotics and drugs are poisons.
3. In every case of poisoning the stomach and intestine should be emptied at once, and a stimulant with an *antidote* to destroy the poison should be given.
4. Spoiled or poisonous food produces stomach and intestinal disturbance. It should be expelled from the body as soon as possible.
5. The active principles of many vegetable drugs are called *alkaloids*.
6. Leucomaines and ptomaines are substances resembling alkaloids, but are produced in the bodies of animals.
7. The poisons of snakes and insects are substances like leucomaines, and are injected into the flesh by means of a hollow tooth or sting.

REVIEW TOPICS

1. Describe the nature of *disease* and how drugs tend to restore health.
2. Describe the general signs and treatment of *poisoning*.
3. Describe the treatment of poisoning by *acids*, and by *alkalies*.
4. Describe *carbolic acid* poisoning and its treatment.
5. Distinguish between the drowsiness due to narcotic poisoning and a fainting spell.
6. Describe *strychnine* poisoning and its treatment.
7. Describe poisoning by *arsenic* and give its treatment.
8. Give the signs and treatment of poisoning by *metals* in general.
9. Describe *phosphorus* poisoning and give its treatment.
10. Describe poisoning by *aconite*; by *belladonna*.
11. Describe poisoning by *mushrooms*, and by decayed food.
12. Describe *alkaloids*, *leucomaines*, *ptomaines*, and their poisonous effects.
13. Describe hypodermic injections.
14. Describe *snake* and *insect bites* and give the treatment.

1. 23.22
20 min.

CHAPTER XVIII

THE BLOOD

272. The circulatory system. — Nature has provided an intricate arrangement of tubes to conduct food to each cell of the body, and to wash away its waste matter. These two objects are accomplished by the *blood*. The conducting tubes and the blood which they contain make the *circulatory system*.

273. The blood. — About one thirteenth of the body is a red liquid called *blood*. It consists of a multitude of circular flat red plates, called the *red blood corpuscles* or *cells*, floating in a colorless liquid, which also contains a few round colorless cells, called *white blood corpuscles* or *cells*.



Blood corpuscles
($\times 400$).

- a* a pile of red blood cells.
- b* red blood cells, seen flatwise.
- c* red blood cells, seen edgewise.
- d* white blood cells.

274. Red blood corpuscles. — The red corpuscles of the blood form about 45 per cent of its weight. Each one is a circular flat plate, with rounded edges, and with a depression in the center of each face. Each cell is about $\frac{1}{3500}$ of an inch in diameter and $\frac{1}{12000}$ of an inch in thickness. Each one is of a reddish yellow color, but when great numbers are piled

together they appear bright red. Each corpuscle is composed of a jellylike albuminous substance, four fifths of which is a reddish substance called *hemoglobin*. Hemo-

globin is the essential part of the red corpuscle. It contains a small amount of iron, which gives to it the property of carrying oxygen without itself being oxidized. By means of the hemoglobin the red corpuscles are able to carry oxygen from the lungs to all parts of the body. When the hemoglobin contains a large amount of oxygen the blood is of a bright red color, but as the oxygen is used up it becomes darker, or almost purple. Bright red blood, called *arterial* blood, is continually flowing toward the cells of the body; while that returning from the cells, called *venous* blood, is purple in color, from the lack of oxygen.

275. White corpuscles. — White corpuscles are each about $\frac{1}{3000}$ of an inch in diameter, and are about $\frac{1}{500}$ as numerous as the red corpuscles.

They are round and colorless, and each contains a nucleus. They have the power of changing their shape, and of adhering to the sides of a blood tube, and of passing through its wall, and of moving about between the cells of the body as though endowed with a will of their own. They have important duties to perform in destroying disease germs and other foreign substances, and in the healing of wounds. (See p. 398.)

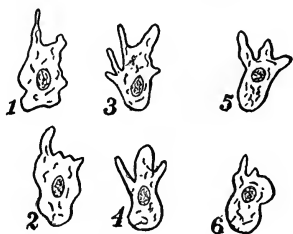

A white blood cell of a frog, sketched at intervals of two or three minutes, showing its changes in form ($\times 300$).

276. Plasma. — The liquid part of the blood is called the *plasma*. It is composed of ninety parts of water, holding in solution about eight parts of albumin and two parts of mineral matter. The mineral matter is mostly soda and potash. This alkaline property of the blood plasma aids it in dissolving carbonic acid gas, and in carrying it to

the lungs, where it is breathed out from the body. Some of the mineral matter of the blood enters into the composition of the cells of the body, especially of bone cells.

The albumin is the substance out of which all of the cells of the body are mainly built. It is formed by the liver out of the peptone which was absorbed from the intestine. A little pressure causes the solution of albumin and minerals to flow through the sides of the capillaries; and thus it reaches the separate cells of the body. Waste matters are continually being poured into the plasma, but they are removed as fast as they enter, so that carbonic acid is the only one to be found except by the most delicate tests.

277. Clotting. — When blood is drawn from the body it soon becomes a jellylike mass, called a *clot*. After a longer time the clot becomes firmer and smaller, squeezing out a clear, straw-colored liquid, called *serum*. The process of changing blood from a liquid to a jellylike form is *coagulation*, or *clotting*. In the process a part of the albumin becomes solidified in small interlacing strings, called *fibrin*, which entangles the rest of the blood into its meshes. The network soon contracts, squeezing out the serum, and retaining the corpuscles. The serum is composed of all the materials of the plasma, excepting the fibrin. The process may be represented thus :

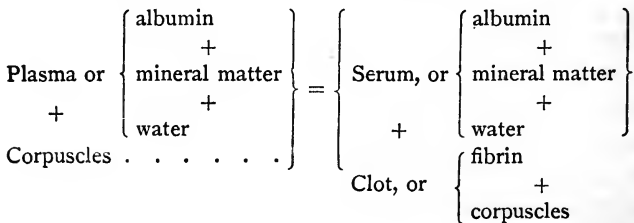

While the blood is in motion within a healthy blood tube, no clotting occurs, but as soon as blood is drawn, it clots, or if a blood vessel is wounded, a clot forms at the wounded spot. The use of clotting is to stop bleeding. Sometimes no clot will form, but a wound will keep on bleeding until it is healed. This is a disease called *hemophilia*, and may cause death.

278. Anemia.— Sometimes there are too few red corpuscles in the blood. Then the skin appears pale and there is shortness of breath, because too little oxygen is carried by the diminished number of red blood cells. The disease is called *anemia*, meaning lack of blood. It is mainly a lack of red corpuscles.

279. Good and bad blood.— The terms *good* and *bad blood* are remnants of the old idea that disease was caused by watery substances, called *humors*, in the blood. From their supposed influence on the mind the terms *good* and *bad humored* are derived.

For many years attempts have been made to inject healthy blood into the veins of sick persons. Injecting a liquid into the veins of a living person is *transfusion*. In bleeding, the loss of water is one of the greatest dangers, and to replace it water is sometimes injected into the veins. It answers better than blood itself.

280. The blood in lower animals.— All living beings possess some form of fluid circulating in their interior. In higher animals, birds, reptiles, and fishes, the fluid is red, and contains both red and white corpuscles. In insects the blood is usually white or colorless. In worms the blood is sometimes colorless and sometimes red or green. In shellfish the blood is colorless, and contains no corpuscles. In animals which are made up of a single microscopic speck of matter, there seems to be a continual motion of fluid within their bodies, although they are so extremely small that nothing definite can be seen.

281. The spleen.—The spleen or milt is a soft red organ, shaped like a tongue, lying just to the left of the stomach. It is composed of small cells and fibers, among which the blood circulates as through a sponge, without being held within firm walled tubes. The spleen is supposed to form the red blood cells, but they are also formed in the marrow of bones. The spleen can be removed with but little harm to the body. The pain in the side caused by running is often due to an excess of blood in the spleen.

SUMMARY

1. Blood is composed of a liquid called *plasma*, in which float great numbers of extremely small *red cells*, and fewer *white cells*.
2. The red cells carry oxygen from the lungs to the cells of the body.
3. The white cells repair injuries to the body.
4. The plasma contains albumin and mineral matters, both of which are food for the cells of the body.
5. The soda of the plasma carries carbonic acid gas to the lungs. The gas is there given off in the breath.
6. After standing outside of the body for a few minutes, some of the albumin hardens to a stringy mass and entangles the cells, forming a clot.
7. All animals possess a fluid somewhat like man's blood.
8. The spleen is a soft organ in which red blood cells are formed.

DEMONSTRATIONS

64. Set aside a spoonful of *chicken's blood* to clot. In a few hours the serum will begin to separate. Breathe on a slide and place a tiny drop of fresh chicken's blood upon it, cover it with a cover glass and examine it with a microscope magnifying at least 200 diameters to see the red blood cells. Notice their oblong shape and their nuclei.

65. *Human blood* may be obtained without pain by tying a string snugly around the finger. After a moment make a quick prick with a clean needle upon the back of the finger just behind the nail. Remove the string, and a drop of blood will flow which can be examined under the microscope. Notice the circular shape of the *red cells* and the absence of nuclei. Notice that they tend to arrange themselves in rows like piles of coins.

66. Place a drop of salt water on the slide by one edge of the cover glass, and notice that the cells become shrunken.

67. *White blood cells* are too few in number to be readily found within a specimen of blood, but they form most of the white matter of a pimple or boil. Prepare and examine a specimen, and notice the dark specks scattered through the cells, and the nuclei which may be three in number in each cell. Add a drop of vinegar and notice that each cell becomes transparent, only the nuclei remaining visible.

68. With a little care the movement of the white cells may be shown in frog's blood. Prepare a fresh specimen of frog's blood upon a slide slightly warmed. After a little search an irregularly shaped white blood cell can usually be found. Watch it carefully, and it will be seen slowly changing its shape exactly as an ameba changes, only more slowly. A magnifying power of at least 200 diameters will be necessary.

69. Prepare a specimen of blood for the microscope. (See demonstration No. 65.) At the edge of the cover glass drop a tiny bit of alcohol. Notice how the red blood cells shrivel and become irregular in form, because the alcohol takes away their water.

REVIEW TOPICS

1. Describe the blood.
2. Describe the red blood cells.
3. Describe the white blood cells.
4. Describe the blood plasma.
5. Describe the clotting of blood.
6. Show what was meant in olden times by the terms *good* and *bad blood* and *good* and *bad humored*.
7. Describe the blood in some of the lower forms of living beings.
8. Describe the spleen and its use.

1. 24. 27

CHAPTER XIX

THE HEART

282. **The heart.** — The blood is kept flowing through all parts of the body by the *heart*. The heart is essentially a

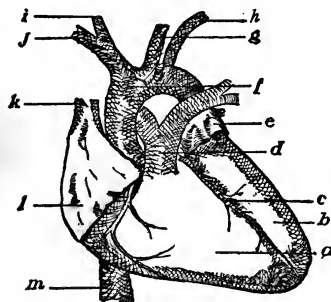

The heart.

- a right ventricle.
- b left ventricle.
- c artery between the two ventricles, nourishing the heart's muscles.
- d pulmonary artery.
- e left auricle.
- f aorta.
- g artery to left side of head.
- h artery to left arm.
- i artery to right side of head.
- j artery to right arm.
- k descending vena cava.
- l right auricle.
- m ascending vena cava.

hollow shell of muscles, which has the power of squeezing its sides tightly together, so as to force out the blood. It is conical in shape. Its side lies upon the diaphragm, with its tip pointing downward, forward, and to the left. Its small end touches the chest wall about two and a half inches to the left of the lower end of the sternum or breastbone, and its large end extends along the right side of the breastbone, from its lower end upward as high as the third rib. It is almost covered by the lung, and is inclosed in a bag of serous membrane called the *pericardium*. The pericar-

dium is very smooth, so as to permit free movements of the heart within it. (See cut, p. 66.)

283. Cavities of the heart. — The heart is designed to pump two separate streams of blood at once. Its left side pumps blood through the whole body, while its right side pumps it only through the lungs. The cavity on each side is partly divided into an upper chamber called an *auricle*, and a lower one called a *ventricle*. Each auricle has thin, flabby walls, and does little of the work of pumping blood.

The ventricles have thick and strong walls, which form nearly all the bulk of the heart. The left ventricle has walls three times as thick as the right ventricle, for it must pump blood through a much greater part of the body. From each ventricle a tube, called an *artery*, conducts the blood away.

284. Valves of the heart.

— Blood enters each auricle through tubes called *veins*, and streams through the opening into the ventricle, but is prevented from flowing back by thin, strong curtains which are attached to the edge of the opening and hang suspended in the ventricle. From the edges of each

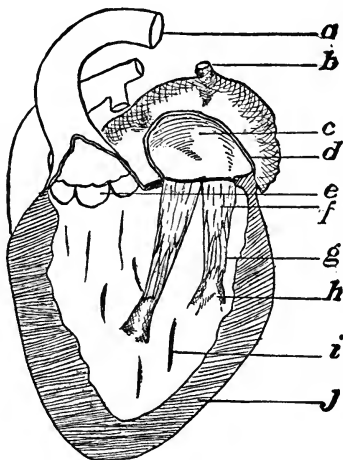

Valves of the heart.

- a* artery with its lower end split open.
- b* vein leading into the heart.
- c* auricle with the front cut away.
- d* cut edge of the auricle, showing its thickness.
- e* semilunar valves; their upper edges are free and movable.
- f* mitral valve spread open.
- g* strings from the edge of the curtain of the valve to steady it.
- h* muscular projection upon the inside of the ventricle to which the strings are attached.
- i* indentations upon the inner surface of the ventricle.
- j* wall of the ventricle, showing its thickness as compared with that of the auricle, *d*.

curtain fine threads extend to projections upon the muscular walls of the ventricle, to keep the curtains smooth and straight. Blood flowing from the auricle into the ventricle readily separates the curtains, but blood pressing upon them from the ventricle forces them tightly together, so

that not a drop can pass through. Thus they form a *valve* in each opening. The valve upon the left side is composed of two curtains, and is called the *mitral* valve. The one on the right side is composed of three curtains and is called the *tricuspid* valve. From their situation, these valves are often called the *auriculo-ventricular* valves.

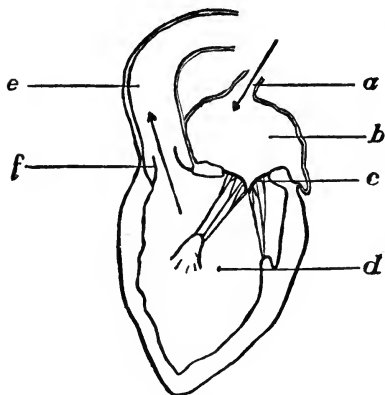

Systole of the heart.

- a* vein entering the auricle.
- b* auricle.
- c* closed valve to keep blood from flowing back into the auricle.
- d* ventricle.
- e* artery.
- f* valve to keep blood from returning to the ventricle.

285. Semilunar valve.

— At the beginning of each artery leading from the ventricles are three thin, silklike flaps, shaped like half-moons. They are arranged so that blood flowing from the ventricle pushes each flap against the side of the artery; but between the beats of the heart, the blood in the artery presses backward, forcing the flaps away from the side of the artery, so that they all meet tightly in the middle. They form a valve called the *semilunar* valve, from the shape of each flap.

286. Action of the heart. — The heart is a pump with valves permitting blood to flow through an auricle into a

ventricle and out into an artery, while preventing any flow in the opposite direction.

As blood enters the heart it passes through the auricles into the ventricles. Just before the ventricles are full the auricles suddenly contract and drive the blood into the ventricles, which are thus filled full and immediately begin to contract, while the auricles relax. The pressure closes the mitral and tricuspid valves and opens the semilunar valves. The blood is thus prevented from flowing back to the auricles, but flows through the open entrance to the arteries. During the contraction of the ventricles, the auricles remain relaxed and receive the blood returning to the heart.

When all the blood is expelled from the ventricle it relaxes, and the blood falls back upon the semilunar valves, closing them so that none returns. At the same time the blood in the auricles presses open the mitral and tricuspid valves, and again fills the ventricles.

287. Rate and time of the heart's action. — The contraction of the heart is called its *systole*, and its relaxation its *diastole*. At each systole from two to four ounces of

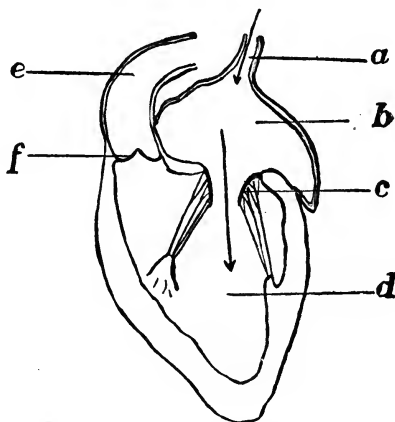

Diastole of the heart.

- a* blood entering auricle.
- b* auricle.
- c* open valve to permit blood to flow into the ventricle.
- d* ventricle.
- e* artery.
- f* closed semilunar valve.

blood are expelled. It occurs about seventy-two times each minute. While the heart beats occur regularly without apparent pause, yet it rests in diastole about one half the time.

288. Sounds of the heart. — Two sounds are produced by each beat, which may be heard by listening with the ear close to the heart. The first sound is the longer and softer, and is caused by the vibration of the contracting muscles. The second sound is shorter and sharper, and is caused by the sudden closing of the semilunar valves. At each systole the portion of the heart touching the wall of the chest may be felt to become suddenly harder, as though it beat against the chest wall. Its movements are transmitted through the chest walls so that they may be plainly seen and felt. Ordinarily a person is not aware of his own heart beats, but when they are very forcible they are plainly felt, and are called *palpitation*.

289. Nerves of the heart. — A nervous mechanism within the heart itself causes it to contract even after it is separated from the body. A fish's or turtle's heart will contract regularly for hours after being removed from the body. Man's heart is easily affected by outside influences, but, because of its own nervous mechanism, it is not so sensitive as has been supposed. Wounds completely penetrating the ventricle have been sewed up, and recovery has taken place. The action of the heart is regulated and adapted to the varying needs of the body through two sets of nerves, one set from the brain and the other set from the spinal cord. In physical exertion the spinal nerves cause it to beat faster and more forcibly. This adaptation is so delicate that rising from a sitting to a standing position perceptibly increases the number of heart beats. Joy, or anger, or excitement of any kind hastens its action, while grief usually retards and weakens it.

290. Effect of violent exercise. — In prolonged and violent physical exercise the heart performs more work than

is natural, and grows larger to accommodate itself to the strain. Repeated calls to extra exertion may cause it to respond more quickly and with more vigor than occasion demands, so that a slight excitement or exertion causes palpitation. Those who engage in races are especially liable to overwork their hearts.

291. Palpitation of the heart. — The response of the heart to influences from the outside may be excessive, so that it beats too quickly and more forcibly than occasion demands. Sudden noises, and excitement of any kind, cause the heart to beat violently or *palpitate* in some persons. But palpitation of the heart is an annoyance rather than a disease. While the will has no control over the heart, yet it can control the emotions which cause the palpitations. Persons of calm temperament, who exercise self-control over their emotions, are rarely troubled with palpitation. Our words ending in "hearted," as "warm-hearted," are records of the old belief that the heart governed the feelings instead of the feelings affecting the heart.

292. Fatty heart. — The heart may become diseased, but heart disease is by no means so dangerous as is commonly supposed. In fact, those having diseased hearts are usually unaware of it for years, while, on the other hand, those who think their hearts are diseased are almost always mistaken.

There is a common change of the heart's muscle, in which little particles of the muscle cells are changed to *fat*. The cells are thus weakened, and made unable to respond to a sudden extra demand. A person with excessive development of fat elsewhere, is liable to have a fatty heart. Avoidance of things which tend to cause excitement and overwork will enable such a heart to work on without noticeable change in its actions.

293. Disease of the valves of the heart. — The other common form of heart trouble is a thickening and puckering of the valves, causing a leakage so that some blood flows backward. But the heart grows larger and stronger,

so that it can pump enough blood to supply the body in spite of the constant leakage backward. The heart may thus become twice its natural size, but there is a limit to its enlargement, and finally it grows weak. If exertion is avoided, such a heart may work perfectly for years.

The nervous system contained in the heart's muscle makes it the most resistant of all the organs of the body, and the one whose disease is least to be feared. It is the first organ formed in the child, and is the last to die. When it begins to fail, the blood accumulates in the lowest parts of the body, and produces swelling of the feet, which is one of the first signs of heart disease.

294. Fainting. — When the heart is suddenly checked and made weak in its action to such an extent that little blood is driven to the brain, unconsciousness and complete loss of muscular power result, so that the person falls to the ground. The face appears pale, because there is but little blood in it. This paleness and loss of consciousness is called *fainting*. When a person faints he should be laid upon his back with his head as low as his body, so that the blood may flow to the brain more easily. Cold water should be thrown upon the face so that the sudden shock may stimulate the spinal nerves which hasten the heart's action. In a few seconds the heart beats become stronger, and consciousness is regained. Remember *not* to raise the head of a fainting person.

295. Effects of alcohol upon the heart. — The first effect of alcohol is to increase the force and frequency of the heart beats. This sends more blood through all the body, and there is a feeling of greater strength, which is called *stimulation*. Men take strong drink for this effect. This feeling comes on within a few minutes after drinking and passes off in the course of an hour. Then the

drinker feels a desire for more alcohol and so forms a habit of its use. While a little alcohol may make a man feel better, yet the strength and endurance of his heart is really diminished. Alcohol is like a whip which makes the heart beat harder for a time but leaves it less able to do its work in the future. Its blow is pleasant at the time it is given, but it is all the more harmful because it is enjoyed.

296. Effects of continuous drinking. — The derangement of digestion and assimilation resulting from long-continued drinking impairs the nutrition of the whole body, including the heart. Drinkers confound the absence of fatigue with strength itself.

297. Effects of tobacco upon the heart. — Tobacco used in any form is a direct poison to the heart's muscle and causes it to beat with less strength. When a large amount is used, it poisons the nerves of the heart and hinders their harmonious action. Then the heart will beat irregularly, and there will be palpitation on slight exertion, so that hard physical exercise becomes an impossibility. The trouble may be only an inconvenience, so that the person cannot engage in violent exercise; but in its severe forms it may be the cause of death.

SUMMARY

1. The blood is kept in constant motion by a double muscular pump, called the *heart*.
2. The heart contains two pairs of *cavities*, each consisting of an *auricle* and *ventricle*.
3. Between each auricle and ventricle there is a *valve* which permits blood to flow into the ventricle, but keeps it from flowing back.

4. Each ventricle contracts upon the blood about *seventy-two* times a minute, forcing it out through a tube called an *artery*.
5. Blood is kept from running back into the heart by a valve at the beginning of the artery.
6. The heart contains a nervous mechanism which makes it partially independent of the rest of the body.
7. The heart has great power of resistance against disease, and of accommodating itself to increased work, so that heart disease is less to be feared than disease of almost any other part of the body.
8. Alcohol at first causes the heart to beat faster and more strongly than the body needs, thus causing it to tire itself out.
9. Alcohol soon weakens the heart by impairing its nutrition.
10. Tobacco makes the heart beat irregularly and with less power.

DEMONSTRATIONS

70. The left side of a chicken's heart closely resembles a man's left auricle and ventricle, and can be used to show the cavities and valves. In removing it, be careful to preserve its covering of pericardium. A pig's, or sheep's, or bullock's heart is more like a human heart. The butcher should be instructed not to cut off the auricles. (See demonstration 35.)

71. The heart of a frog or fish which has just been killed should be removed to show its persistence in beating. (See demonstration 35.)

72. Have the students listen to each other's hearts so as to get a clear idea of the two sounds. Feel the heart beats upon the chest, and notice how they increase in force and frequency when a person rises after lying down, and more yet when he walks and runs.

REVIEW TOPICS

1. Describe the heart: its situation, pericardium, cavities, and valves.
2. Describe the action of the heart and the flow of blood through it.
3. Describe what may be heard, seen, and felt by examining the body over the heart.
4. Describe the nervous mechanism of the heart.
5. Give the effect of violent exercise upon the heart.
6. Discuss palpitation of the heart.
7. Describe a fatty heart.
8. Describe how the valves of the heart may be diseased.
9. Describe fainting and its treatment.
10. Give the effects of alcohol upon the heart.
11. Give the effects of tobacco upon the heart.

CHAPTER XX

THE FLOW OF BLOOD IN THE BODY

298. Arteries. — The tubes which conduct the blood away from the heart are called *arteries*. From the left

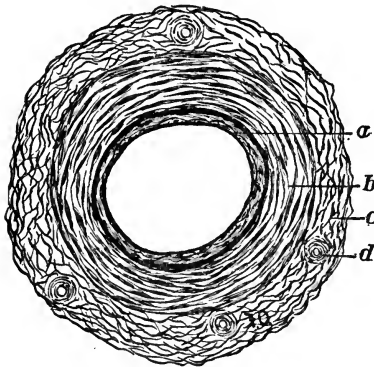

An artery cut across ($\times 200$).

- a* smooth inner coat.
- b* middle or muscular coat.
- c* outer or connective tissue coat.
- d* small artery to nourish the large one.

ventricle there goes a single tube called the *aorta*. It gives off branches, which subdivide again and again, until they are of microscopic size and penetrate to every part of the body.

From the right ventricle there extends another tube, called the *pulmonary artery*, which conducts blood only to the lungs, where it is purified.

299. Structure and action of arteries. — An artery is a muscular tube covered with

a tough layer of connective tissue and lined with a layer of very smooth, platelike cells. Its muscle can diminish the size of the tube. The arteries are elastic, and are always so full of blood that they are somewhat distended. At each systole of the heart, from two to four ounces of additional blood are suddenly forced into the already full aorta. During the heart's diastole, the elasticity of the

artery causes it to contract, forcing the blood onward in a steady stream. But the artery can exert no more power in contracting upon its blood than the heart exerted in distending the artery, and so it is really the heart's force which propels the blood.

300. The pulse. — The extra distention of the aorta by each systole of the heart produces a wave in the blood which runs along the arterial tubes. Wherever an artery runs near the surface, as in the wrist, the wave may be felt, and is called the *pulse*. The pulse is not a sudden current of blood shot through the artery, but is a *wave* in the steady stream. By means of the pulse the frequency and regularity of the heart beats may be determined. When an artery is cut, a continuous jet of blood spurts out to a considerable distance, which momentarily increases in size with each wave beat.

301. Capillaries. — The smallest arteries suddenly divide into an extremely fine network of tubes, called *capillaries*. Each capillary tube is from $\frac{1}{2000}$ to $\frac{1}{3000}$ of an inch in diameter, and from $\frac{1}{1000}$ to $\frac{1}{50}$ of an inch in length. It is composed of the same kind of smooth and flat cells as those which line the arteries; in fact, the capillaries are the prolongation of the linings of the arteries. They penetrate the spaces between the cells of the body in such a close network that several capillaries may be in contact with each cell, and the point of a fine needle cannot be thrust into the body without wounding some. The blood in the capillaries gives the pink tinge to the skin, which disappears when the blood is pressed out. The total capacity of the capil-

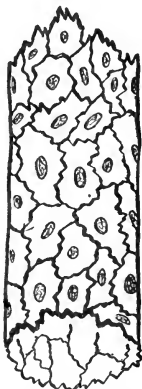
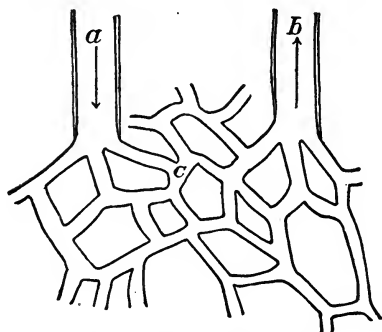

Diagram of a capillary, showing the platelike cells of which it is composed ($\times 500$).

laries is about three hundred times that of the arteries, and hence the blood pressure is much less than in them; yet the pressure is always sufficient to keep the blood in steady motion.



Arrangement of capillaries.

- a smallest artery.
- b smallest vein.
- c network of capillaries.

called *lymphatics*. When a capillary is injured, many of the white cells adhere to the injured spot and furnish food for its repair. They may even grow and change to connective tissue for its further repair.

303. Diffusion of blood plasma in the capillaries.

— The slight pressure to which the plasma is subjected is just sufficient to cause it with its albumin to diffuse through the exceedingly thin wall of the capillary. It fills the spaces between the capillary network and bathes each cell of the body with an abundant supply of nourishment.

302. Action of the white blood cells in the capillaries. — Often a white blood cell will adhere to the wall of the capillary and partially block the blood stream for a moment. It may work its way through the wall of a capillary, and yet leave no hole behind it. Many are thus found in the spaces outside the capillaries, and are finally returned to the heart by means of another set of tubes

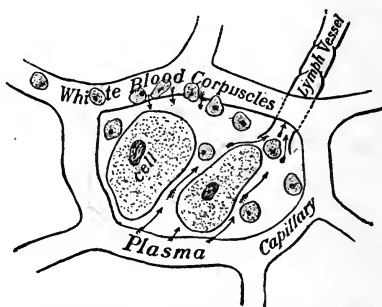

Diagram showing how food reaches the cells from the capillaries.

It fills the spaces between the capillary network and bathes each cell of the body with an abundant supply of nourishment.

304. Exchange of oxygen and carbonic acid in the capillaries. — The blood in a capillary is separated from a living cell of the body by a wall so thin that it is no hindrance to the passage of oxygen from the red blood cells. In return for the oxygen received from the blood, the body cells give out carbonic acid gas, which passes through the capillary walls into the blood as readily as the oxygen passes in the opposite direction. A given particle of blood remains in a capillary only a second at most, and in that time there occurs an exchange of oxygen and nutritive matter between the blood and the body cells. Arteries are simply tubes which conduct blood to the capillaries, where all the actual work of nourishing the cells is performed.

305. Veins. — The network of capillaries at the end of each artery unites to form a single tube, called a *vein*. Each vein unites with others again and again, to form larger tubes which run alongside of each artery, and finally all unite to form two main veins. One vein, called the *descending vena cava*, returns blood from the head and arms; the other, called the *ascending vena cava*, returns blood from the lower extremities and trunk. Each opens into the right auricle. The veins have about three times the capacity of the arteries. Their walls are composed of the same material, but are very much thinner, for they do not have to stand much pressure of blood. The blood current is correspondingly slow. The veins have *valves* at intervals which permit of a free flow toward the heart, but oppose its passage backward, so that when a vein is pressed the blood is forced only towards the heart. The contraction of the muscles pressing upon the veins is thus a great aid to the flow of blood. The flow of blood is also aided by the movements of the chest in breathing,

which suck venous blood toward the heart just as it sucks air into the lungs.

306. Pulmonary circulation. — As the blood enters the veins from the capillaries, it has lost some oxygen and gained carbonic acid gas and other waste matter. This makes it much darker in color. Before it is used again it is purified and given a new supply of oxygen. For this purpose it is sent to the lungs as soon as it reaches the heart.

From the veins the blood flows into the right side of the heart, and then to the lungs through the pulmonary artery. The pulmonary artery divides again and again into small twigs, and these divide into a close network of capillaries

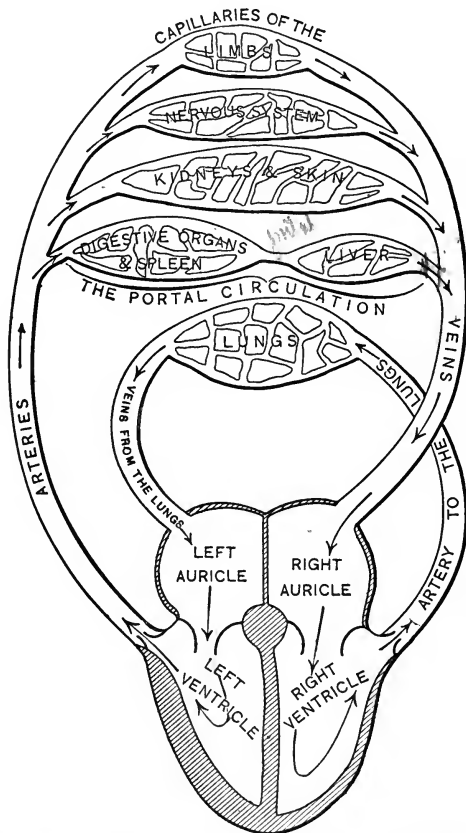

Diagram of the course of the blood in the circulation.

within the lungs, where the blood is separated from the air by only the thin walls of the capillaries. Through these

thin walls the oxygen of the air readily penetrates to the red blood cells; and the carbonic acid gas just as readily passes from the blood to the air. As a result of this change, the blood becomes of a bright red color, and is called *arterial* blood. From the capillaries of the lung the arterial blood is collected into the *pulmonary veins* and carried to the left auricle, and then to the left ventricle, where it is ready to make another circuit of the body.

307. Summary of the circulation of the blood. — In making a complete circuit of the body the blood passes through the *left auricle*, and through the *mitral valve* to the *left ventricle*; then past the *left semilunar valve* to the *aorta*, and then through the *arteries* to all parts of the body; then through the *capillaries* into the *veins*, and back to the heart; next through the *right auricle*, then the *right ventricle*, then through the *pulmonary artery* to the *capillaries* of the *lung*; then through the *pulmonary veins* to the *left auricle* once more. Thus in making the complete circuit of the body, a drop of blood passes through the heart twice, and through *two* different sets of capillaries. The circuit of the body in general is called the *systemic circulation*, and that through the lungs is the *pulmonary circulation*.

308. The portal system of circulation. — The blood from the capillaries of the stomach and intestine is collected into a single vein, called the *portal vein*, which goes to the liver and there divides into capillaries. The liver capillaries can be considered as millions of small tubes which are substituted for a few inches of the portal vein. Just outside of the liver they empty into three veins which open into the ascending vena cava. The circulation through the liver is sometimes called the *portal circulation*.

309. Time required in the complete circulation. — It requires about twenty seconds for a drop of blood to go the round of the circulation from the left ventricle back to its starting point. All the blood passes through the heart about once every two or three minutes. All the arteries, except the pulmonary artery, carry bright red arterial

blood, while all the veins, excepting the pulmonary veins, carry dark red or venous blood.

310. The lymph.—In order to nourish the body, the plasma of the blood is continually being diffused through the capillaries into the spaces between the living cells. Each cell is thus bathed in a plentiful supply of plasma, from which it absorbs its nutriment. The spaces also contain many white cells, which have left the capillaries. The blood plasma and blood cells filling the spaces between the cells are called the *lymph*, and the spaces are called *lymph spaces*.

The lymph is a thin, colorless fluid. In fact, it is blood without the red corpuscles, but with many waste matters from the cells of the body added. The lacteals of the

intestine are also lymphatics which carry the digested fats, and hence their lymph is of a milky-white color.

311. Lymphatics.—Lymph is continually collecting, and its removal is provided for by means of a set of tubes, called the *lymphatics*. The smallest lymphatic tubes are much

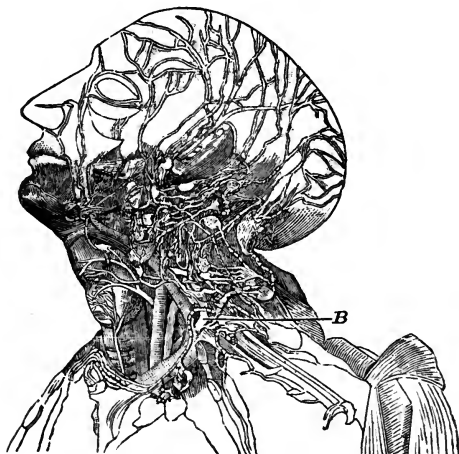

Lymphatics of the head and neck.

B thoracic duct.

smaller than a capillary, and their walls are so thin that they can scarcely be seen with a microscope. Each begins in the open space between a capillary and a cell of the

body. They unite again and again to form about twenty main trunks for each limb. Each trunk extends upward, and most of them finally unite to form a tube of the size of a goose quill, called the *thoracic duct*.

The thoracic duct lies upon the spinal column, and extends upward into the neck, where it opens into a large vein. The lymphatics have numerous valves, all opening toward the heart. They prevent the backward flow of lymph.

312. Lymph nodes.—At irregular intervals the lymphatics open into small, baglike bodies composed of a spongy network of fibers filled with cells, some of which become white blood cells. Each body is called a *lymph gland* or *node*. The lymph flows through these nodes as water flows through a filter. They strain out matters which are injurious to the system, while their cells envelop and destroy poisons and disease germs, and so they protect the rest of the body.

The lymph nodes may be felt in the neck and groins and armpits, as small kernels about the size of a grain of wheat or corn. When the lymph carries certain kinds of poisons, they swell up and produce the disease called *scrofula*. In boils, erysipelas, and other inflammations, they swell and become very tender and sometimes break down and form abscesses.

313. Flow of the lymph.—A little pressure transmitted from the blood in the capillaries is exerted upon the lymph,

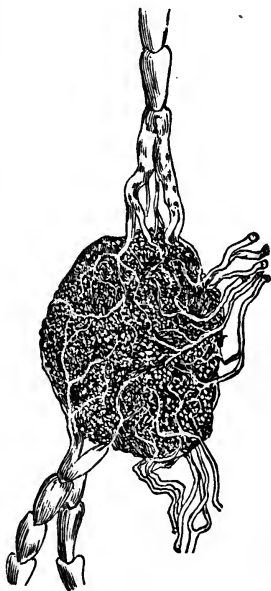

Lymph node and vessels
($\times 10$).

but not enough to force it along the lymphatics. Its flow is aided by the pressure of muscles upon the spaces and the tubes. Its current is slow and unsteady. It is finally poured through the thoracic duct into a vein at the root of the neck, where it mingles with the blood. About two quarts of lymph pass through the thoracic duct daily. If a hollow needle is thrust into the skin, and through it water containing medicine is forced, the medicated water spreads through the lymph spaces between the living cells. Some is taken up by the capillaries, and some passes into the circulation by means of the lymph, and produces the same effect as though it entered the blood through the stomach.

Sometimes the lymph cannot be removed by the lymphatics so fast as it is poured out by the capillaries. It then distends the lymph spaces, producing uniform swellings called *dropsy*. Dropsy can be recognized by a small pit remaining when the finger is pressed into the skin.

314. The circulation in lower animals.—Land animals and birds possess a heart and blood tubes like man's, and their circulation follows the same order. The heart of reptiles and toads consists of two auricles and one ventricle, and the ventricle always contains both arterial and venous blood.

Fishes possess only one auricle and one ventricle. The ventricle forces the blood through two sets of capillaries, and the circulation is made correspondingly sluggish.

Insects possess a row of eight or nine sacks connected by a tube, with valves opening toward the head. The contraction of the sacks forces the blood toward the head, where it escapes into the lymph spaces between the cells. There are no arteries or veins, and so the blood is slowly

forced toward the back part of the body through the lymph spaces until it again reaches the tube. Their circulation is thus like the circulation of lymph in man.

Shellfish usually possess a heart and arteries and veins. In the very lowest animals, like the ameba, there seems to be a flow of fluid within the body, but no part of the body is set aside for the purpose.

315. History of the knowledge of the circulation. — The ancients thought the heart was the seat of life, because the heart was seen to be the first organ formed in an egg which was being hatched. The idea was confirmed to them by the heart's constant action, which they thought was caused by the boiling of the animal spirits. The spirits then flowed away in a sluggish stream through the veins, and were not supposed to return to the heart.

They concluded that the arteries carried only air, because they always found them empty after death. They knew nothing whatever of the capillaries. They thought that food was carried to the liver and was there partly cooked, and was then sent on to the heart where it was cooked still further in the heart's vital flame, until it was turned to blood. Then it was sent out by way of the veins to irrigate the body. The valves of the veins were supposed to oppose its flow and to render it sluggish. The boiling in the heart was supposed to heave the chest up and down, and cause air to rush in and prevent too great a degree of heat. The brain also was supposed to cool the blood. Because of its more violent action during physical exertion or emotion, they concluded that the heart, instead of the brain, was the seat of the mind and feelings. We still use the word *heart* with this meaning in such expressions as *kind-hearted* and *free-hearted*.

Incredibly few discoveries were made for thousands of years, for until within two hundred years the law forbade any one to dissect a human body. In 1628 a true explanation of the heart and the course of the blood was first published by Harvey, an English physician. The only point which he omitted was the explanation of how the blood gets from the arteries to the veins. Three years after his death microscopes were made powerful enough to reveal the capillaries for the first time, and thus the truth of our present ideas concerning the circulation was fully established.

SUMMARY

1. The tubes carrying blood away from the heart are called *arteries*. They are thick-walled and elastic, and in them the blood is under considerable pressure. Each heart beat causes a perceptible wave in the artery, which is called the *pulse*.
2. The arteries divide and finally break up into fine tubes called *capillaries*, which touch each cell of the body.
3. In the capillaries some of the plasma passes outside the tubes and bathes the cells in nourishment. Some of the oxygen leaves the red blood corpuscles to go to the cells of the body. Some carbonic acid gas also leaves the cells of the body and combines with the plasma within the capillary.
4. The capillaries join together to form thin-walled vessels called *veins*, which return the blood to the heart.
5. The plasma which has left the capillaries is called *lymph*. It is returned to the blood by means of a set of fine tubes called *lymphatics*.
6. The lymphatics unite to form a tube called the *thoracic duct*, which runs up the backbone and opens into a vein at the root of the neck.
7. The right side of the heart sends the venous blood to the lungs, where it passes through the capillaries and is freed from its impurities, and then returned to the left side of the heart as arterial blood ready for another circuit of the body. This is called the *pulmonary circulation*.
8. The venous blood from the stomach and intestine passes through a second set of capillaries in the liver. This is called the *portal circulation*.

DEMONSTRATIONS

73. The flow of blood in the veins and the action of the valves of the vein can be shown by placing a finger upon a vein in the skin upon the back of the hand. Then press out the blood by running another finger a few inches up the vein. When the second finger is removed, notice that the blood does not return in the vein, for the valves stop the backward flow; but if the first finger is removed, the vein at once fills up. This is one of the proofs which Harvey used to prove the circulation of the blood.

74. The position of the main arteries upon the limbs should be shown upon the body. Remember that they are usually over the middle of a joint upon the side toward which it can be bent. Explain that wherever a beating can be felt there is a pulse and an artery.

75. Examine an artery and vein prepared for the microscope. Notice its smooth and thin inner layer puckered because of the contraction of its outer coats. Next is the muscular layer, each cell wrapped around the tube. The next and outermost layer is composed of connective tissue. Notice that the main difference between the artery and the vein is that the artery is thicker.

76. Tie a string or a rubber band rather tightly around the finger. Notice that in a few minutes the finger becomes purple, cold, swollen, and painful. Explain that the string does not exert enough pressure to close the thick arteries which are under high pressure, but that it readily closes the veins.

77. Show the capillary circulation in a frog's foot. Place the frog in a covered glass of water to which a teaspoonful of ether has been added. When it ceases to move, spread its web over a hole cut in cardboard. A ring of dried mucilage will hold it in place. Examine it under a microscope with a magnifying power of about 200 diameters. Oval cells will be seen shooting through a network of capillaries. The tail of a small fish also will show the circulation.

REVIEW TOPICS

1. Describe the tubes which conduct blood to the cells of the body, their structure, situation, arrangement, action, and pulse.

2. Describe the *capillaries*, their structure, and action in regard to nutrition and respiration.
3. Describe the *veins*, their structure and action.
4. Describe the pulmonary circulation and the portal circulation.
5. Give the time required for a drop of blood to make the complete round of the circulation.
6. Describe the lymph, the lymphatics, the flow of lymph, and the use of lymph.
7. Describe *lymph nodes* and give their use.
8. Describe the circulation in reptiles and toads, in fishes, in insects, in shellfish, in the ameba.
9. Give an outline of ancient ideas concerning the circulation of the blood, and tell when and by whom the true circulation was discovered.

CHAPTER XXI

REGULATION OF THE FLOW OF BLOOD

316. Vaso-motor nerves.—The muscles in the walls of the smaller arteries regulate the amount of blood passing through them. A special set of nerves, called *vaso-motor nerves*, causes the arteries to contract. When these nerves are paralyzed, the muscles relax, and the artery becomes fully distended by the pressure of the blood. When any part of the body is working, its arteries dilate in order to supply a greater amount of blood to the part.

The vaso-motor nerves are affected by influences from the brain. Embarrassment and bashfulness paralyze those of the head, so that more blood goes to the face and it becomes redder, or blushes. On the other hand, fear and grief stimulate the nerves and cause a contraction of the arteries, which drives the blood from the face so that paleness results. *Heat* applied to the skin causes the arteries to *dilate*, and thus to contain more blood.

317. Congestion.—More than the natural quantity of blood remaining in a part for some time is called *congestion*. It is liable to injure the cells. Cold causes the arteries of the skin to *contract* so that less blood passes through them, and consequently an extra amount of blood flows through the deeper arteries. So congestion of the deeper parts often results, and the injured cells become unable to resist the growth of disease germs. In this way we often take cold.

318. Secondary effects of heat and cold.—When heat has acted upon the skin for some time it causes a contraction of the blood tubes. When first put into a tub a washerwoman's hands become

red, but in a few moments they become white and shriveled from the contraction of the arteries.

When cold has acted upon the arteries for some time it paralyzes them so that they dilate. When a boy begins to snowball, his hands are cold, but after a while his hands glow with redness and warmth because the paralyzed tubes admit more warm blood.

319. Effects of injury upon the arteries. — When injured in any way, the injured part becomes red and warmer. This is because the same cause which produces the injuries also partly paralyzes the smaller arteries, so that they dilate and bring an extra quantity of blood for the repair of the wounded part. Here, as elsewhere, nature wonderfully adapts the body to its surroundings.

320. Nature's arrest of hemorrhage. — Cut capillaries cause only an oozing of blood which collects like drops of

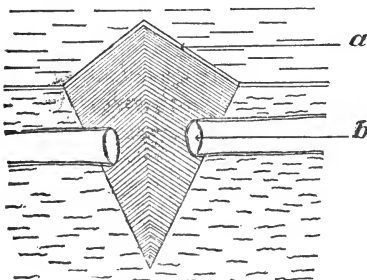

Diagram of a bleeding cut.

- a* upper edge of a cut.
- b* a cut blood tube.

dew over the whole cut surface. Blood does not spurt from a cut vein, but wells out in a slow stream.

When an artery is cut, the blood flows in a strong jet. Bleeding from either of the vessels usually stops in a few moments. The muscles of the blood tube contract and lessen the size of the tube, or even

entirely shut it up; the blood also clots in the cut, and a small plug of clot extends into the end of the blood tube. In these two ways bleeding from small cuts is soon stopped naturally. But in a large artery the blood pressure is so great that it forces away the clot as fast as it is formed, so that bleeding may continue until death occurs.

321. How to stop a bleeding. — It should be remembered that sufficient pressure will instantly stop any bleeding. If a hand is placed on each side of the cut, so as to hold its edges firmly together, no bleeding can occur. A second way of stopping bleeding is by pressing a handkerchief, or a finger, or even the whole hand, into the wound. A third way in which bleeding may be stopped is by cutting off the supply of blood to the part. This may be done by tying a handkerchief very tightly around the limb between the wound and the heart. The knot in the handkerchief should lie over the artery, and, if necessary, a stick may be inserted under the band and twisted tightly. Of these three ways of stopping bleeding, that of compression by the hands is the best to use at first.

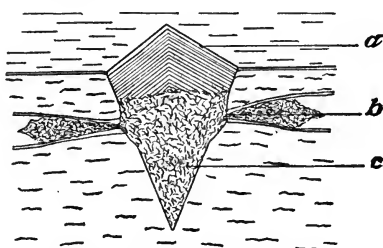

Natural stoppage of bleeding.

- a* upper edge of a cut.
b blood tube, showing its contracted cut end filled with a clot.
c blood clot.

322. Position of arteries. — Main arteries run in a general direction down the middle of each limb, upon the side on which the limb can be bent. Thus in the upper part of the arm, the artery runs across the center of the armpit, and then down the inner side of the upper arm. At the elbow it lies in the center of the front side of the arm. An artery lies upon the thumb side, and another upon the little finger side of the front of the wrist.

In the leg the main artery lies in the middle of its upper part, and reappears at the surface in the middle of the bend of the knee. At the ankle it is divided into two, one of which is just behind the inner ankle bone, and the other runs down the middle of the front of the foot.

There is a large artery and a large vein in the middle of each side of the neck. These positions should be remembered, for they are the principal places in which a large blood tube is likely to be wounded,

and they mark the course of the tubes in case they should need to be compressed to stop bleeding.

323. Repair of wounded tubes.—When a vein is cut in two, its ends may grow together again, but when an artery is cut, each end of the tube remains permanently

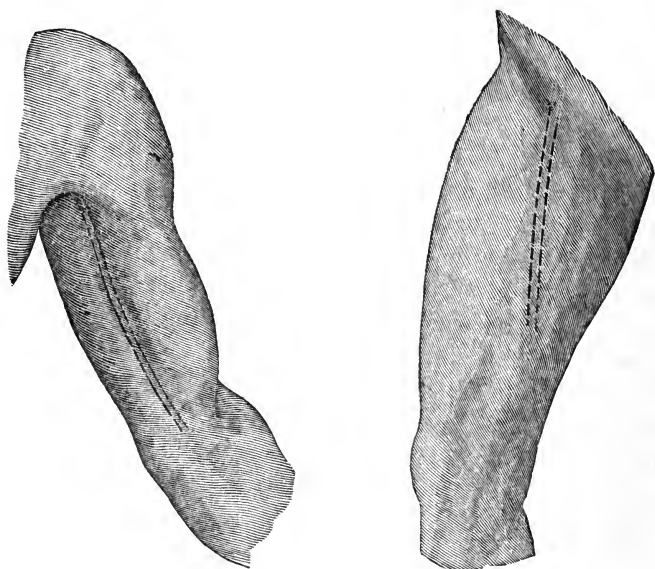

The left upper arm.

The dotted line indicates the course of the main artery (the brachial).

The right thigh.

The dotted line indicates the course of the main artery (the femoral).

closed, and thus the supply of blood to the part is at least partly cut off. Branches from an artery communicate with other branches which begin a few inches further down the same artery. When the artery is cut, these communicating branches enlarge, and thus permit the natural amount of blood to flow around the wound and

so reach the artery below the cut. When capillaries are cut, a new set is produced to take their place.

324. Effect of tight bands. — A tight band will obstruct the flow of blood in the veins, while, unless it is very tight, it scarcely affects the arteries. So the blood freely enters a part through the arteries, but is held back in the veins below the band, until the part is distended with blood, and the proper amount of new arterial blood is prevented from entering. As a result the nutrition of the part suffers and slight injuries do not heal readily. The veins swell from the extra amount of blood they contain, and finally enlarge in places, forming what are called *varicose veins*. Tight garters are common offenders in this respect.

325. Alcohol and arteries. — When a cup of hot coffee is swallowed, the temperature of the stomach and of the blood in its walls is raised. Then nature at once causes the arteries of the skin to become enlarged so that more blood may come in contact with the cool air, and thus give off the surplus heat. Probably in the same manner the heat produced by the destruction of alcohol causes the arteries of the skin to dilate so that they contain an excess of blood. A red face and nose are well-known signs of drinking. This dilation of the arteries is one of the most marked and constant effects of drinking.

326. Alcohol and the nutrition of cells. — Naturally, when a part of the body is at work, its blood tubes become larger, while those of the resting parts become smaller. If the blood tubes of distant parts remain large, there will not be sufficient blood to fill those of the working part, and thus the part will not be able to put forth its full strength. If a part is injured, it cannot get enough extra blood to repair itself quickly. Thus wounds will be apt to heal slowly, while inflammation will be more likely to set in.

If a part is continuously supplied with an excess of blood by dilated arteries, there is apt to be an overgrowth of some of its tissues, especially of connective tissue. An excess of this tissue interferes with the action of the working cells of the part. This change is apt to occur especially in the arteries themselves, making them thick and hard. It naturally comes on during old age, but is often hastened by the use of strong drink. The affected arteries cannot change their size, and so the parts which they supply suffer in nutrition. Although an excess of blood may go to a part, yet it is not renewed so often as it should be.

SUMMARY

1. The muscles in the arteries give them the power of becoming smaller or larger in order to regulate the amount of blood going to any part of the body.
2. The contraction and relaxation of the arteries is controlled by a set of nerves called vaso-motor nerves.
3. Heat, cold, work, and mental influences are a few causes which excite the action of the arterial muscles.
4. Contraction of arteries near the surface and dilatation of the deeper ones is the common cause of taking cold.
5. Alcohol causes a paralysis of the muscles of the arteries so that they may remain permanently enlarged. The arteries of the face and stomach are most affected.
6. Small blood tubes, when cut, bleed for a moment until the ends of the tubes contract and a clot plugs them up completely.
7. Large blood tubes may bleed until death occurs. Bleeding can always be stopped by grasping the part boldly and firmly.

CALIFORNIA COLLEGE of PHARMACY

REGULATION OF THE FLOW OF BLOOD

191

8. Large blood tubes run down the middle of the limb upon the side toward which the limbs are bent.
9. Tight bands obstruct the flow of blood going from a limb, but permit blood to enter. Thus the limb swells and the veins enlarge.

DEMONSTRATIONS

78. The effect of injury upon the arteries can be illustrated by scratching the arm with the point of a pin. In a few seconds a bright red mark appears in its track.

79. Hold the hand in a basin of hot water. Notice that at first the skin is red from the dilatation of the arteries. In course of ten minutes the skin becomes white and puckered, because heat has a second effect of contracting arteries.

80. Show how bleeding can be stopped, by boldly grasping an imaginary cut and holding its edges tightly together. Show how a band can be tied loosely around a limb above a cut, and then by means of a stick inserted under the band, can be twisted as tightly as one pleases so as to control bleeding.

REVIEW TOPICS

1. Describe *vaso-motor nerves*.
2. Show how vaso-motor nerves are affected by influences from the brain; by heat and cold; by injuries.
3. Describe congestion and how it is caused by cold.
4. Give the effects of alcohol upon the contraction and dilatation of the arteries.
5. Give the difference between arterial, capillary, and venous bleeding.
6. Describe how bleeding naturally stops.
7. Describe three ways of stopping bleeding.
8. Describe how nature restores the circulation after an artery is cut in two; after a vein is cut; and after capillaries are cut.
9. Give the effect of tight bands upon the circulation of a limb.

CHAPTER XXII

THE LUNGS

327. Oxidation.—Life is a process of oxidation. The body is an engine. The living cells are the machinery, and both they and the blood are the fuel. The fires are lighted at birth, and burn without cessation until death.

328. Respiration.—In every fire a free draft of air must be supplied and the burned products must be carried off. So in the body air must enter continually, and the oxidized products pass out again. The red blood cells are set apart for the special work of carrying oxygen to the rest of the cells of the body, while the lungs are arrangements in which the red blood cells can obtain oxygen from the air. The passage of air into and out of the lungs is *breathing*. Breathing and oxidation together constitute *respiration*.

329. Respiratory organs.—An air tube leads from the surface of the body to the lungs. The parts of the tube from the surface to the lungs are the *nose, pharynx, larynx, trachea, and bronchi*. These parts taken together form the *respiratory tract*. They, together with the lungs and red blood cells, form the *respiratory system*.

330. The nose.—The nose is a double tube lined with mucous membrane. Each tube has a smooth bottom and inner wall, but its outer wall is thrown into three curved folds extending lengthwise so as almost to form partitions across the tubes. The folds warm the air and strain out dust as it passes over their surfaces. From each side of

the nose a tube extends to the eye to drain away tears, and another opening extends into the *antrum* or cavity in the upper jawbone. In the nose there are special nerves of the sense of smell. (See p. 324.)

331. The pharynx.—The pharynx is the muscular bag just back of the mouth, through which both food and air pass. Air should always enter it from the nose. Just in front of the pharynx upon each side is a fleshy body, looking like an almond, and called the *tonsil*. Sometimes the tonsils become very large in children and close the opening into the nose, making it necessary to breathe through the mouth.

332. Adenoid vegetations.—In the upper part of the pharynx, just behind the opening of the nose, there often grows a collection of soft, grapelike bodies, called *adenoid vegetations*. They close the opening to the nose and compel a person to breathe through the mouth. They begin to form during early childhood while the bones are growing. The unnatural breathing and open mouth deform the upper jaw so that it becomes narrow and pointed. The trouble is a serious one, for it compels mouth breathing; it renders the child very susceptible to taking cold and other infectious diseases; and it is the most common cause of deafness, for it stops the Eustachian tube leading to the ear. Often adenoids are associated with large tonsils.

When a child becomes grown, the adenoids often shrink, and so cure themselves, but the deformed jaw lasts through life. They can easily be broken down and removed, and this should be done in every case.

333. Mouth breathing.—The mouth contains no means for warming the air, or for screening out dust and disease germs, as the nose has. So a mouth breather is very likely to take cold. When he

makes an extra exertion and becomes short of breath, the air irritates the throat and brings on a cough.

With many, mouth breathing is a habit which can easily be broken by attention to the breathing. In others, it is due to a cold, or to adenoid vegetations, or to enlarged tonsils.

334. The larynx.—In the front side of the lower part of the pharynx is the opening of a box called the *larynx*, through which air passes. The larynx is a box of carti-

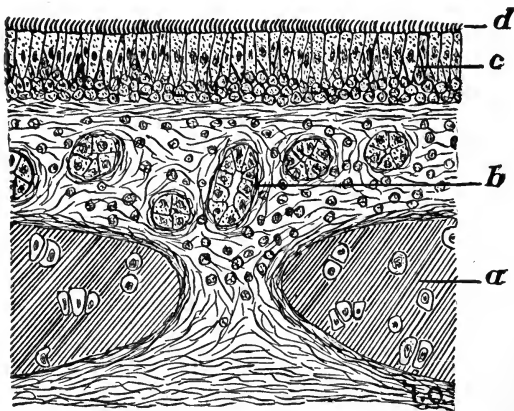

A slice from the trachea ($\times 200$).

- a* cartilage. *b* glands in the mucous membrane.
c lining of epithelial cells.
d cilia upon the surface of the epithelium.

lage. Across its upper end are stretched two thin elastic bands, the vocal cords, which can be tightened and brought near together at will. Air passing between them produces a sound called the *voice*.

335. The trachea.—From the bottom of the larynx there extends downward a tube called the *windpipe* or *trachea*. The trachea is about four and one half inches in length and three quarters of an inch in diameter. It is composed of a framework of twenty hoops of cartilage,

bound together with tough connective tissue and lined with mucous membrane.

336. The bronchi. — Within the chest the trachea divides into two tubes, the *bronchi*. Each bronchus divides again and again, until the finest divisions are about $\frac{1}{75}$ inch in diameter. Like the trachea, each bronchus is composed of hoops of cartilage lined with mucous membrane.

337. Cilia. — The surface of the epithelium of the mucous membrane of most of the nose and larynx and the whole of the trachea and bronchi is covered with microscopic hairs, the *cilia*. Each cilium is slightly curved upward and waves continually in a rapid up and down motion which tends to force dust and mucus away from the lungs.

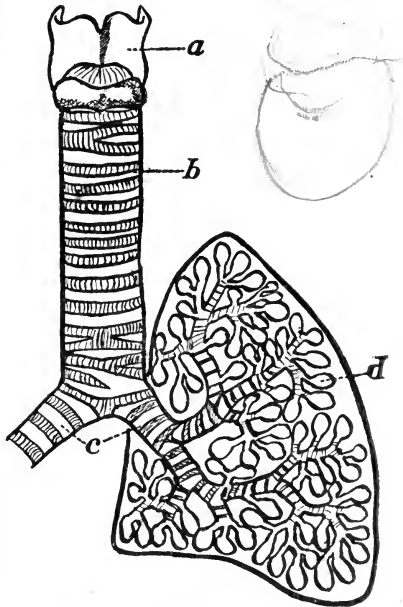

Diagram of trachea and bronchi.

a larynx. *b* trachea. *c* bronchi. *d* air sacs of the lung.

338. The lungs. — The ends of the bronchi are studded with numerous cup-shaped depressions called *air sacs*, each about $\frac{1}{100}$ inch in diameter. Upon the inner surface of each air sac is a close network of capillary blood tubes. The collection of bronchi, air sacs, and blood tubes forms two spongy bodies called *lungs*. Between the air sacs is a thin layer of connective tissue. The lungs can be

stretched like rubber bags, when air is blown through the trachea, and will contract to their former size when the air has been let out.

339. The chest or thorax.—The lungs are covered by the ribs, which are hinged to the spinal column behind, and to the breastbone in front, so as to form a bony frame-

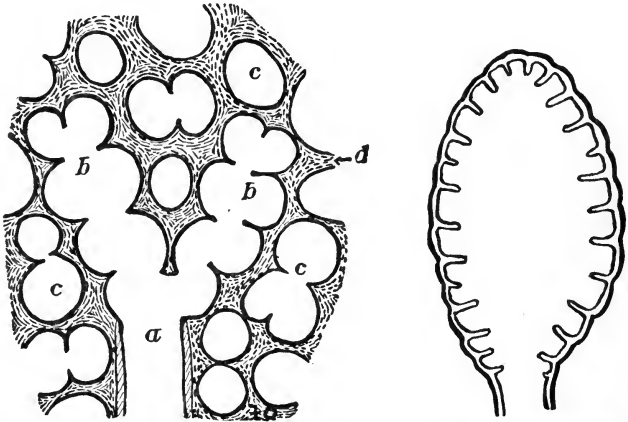

Diagram of the air sacs in a man's lung.

- a* smallest bronchial tube.
- b* a collection of air sacs cut lengthwise.
- c* air sacs cut across.
- d* connective tissue between the air sacs.

Diagram of a frog's lung.

work inclosing a cavity called the *chest* or *thorax*. The floor of the thorax is formed by a muscle called the *diaphragm*, which is attached to the lower border of the ribs, and arches upward. It is lined with a smooth and shining serous membrane like peritoneum, called the *pleura*. Each lung is covered with pleura also.

340. Inspiration and expiration.—Muscles connect and cover the ribs. They raise the ribs and expand the chest. The diaphragm flattens its arch and makes the chest

deeper. Thus the size of the chest can be increased in all directions. When the chest expands, air rushes in to distend the lungs. The entrance of air into the lungs is called *inspiration*. At the end of inspiration the muscles relax. Then the weight of the parts and the elasticity of the distended lung forces out the air. In addition, the muscles of the abdomen and arms can be made to contract so as to expel the air with greater force. Driving out the air from the lungs is called *expiration*.

341. Amount of expansion.—In an ordinary inspiration the chest becomes from one half an inch to one inch larger around. By taking a very deep breath most people can expand the chest two or three inches. An expansion of four or five inches is exceptional. By breathing exercises the expansion can be increased.

342. Amount of air used in each breath.—After the fullest possible inspiration, the lungs contain about 330 cubic inches of air. After the fullest possible expiration, the lungs still contain about 100 cubic inches of air. So it is possible, by strong effort, to inhale and exhale about 230 cubic inches of air. This is called the *vital capacity* of the lungs, and is the breathing power which can be used in violent exercise. But in quiet breathing only about 30 cubic inches of air are inhaled. This is called *tidal* air. By an effort about 100 cubic inches of air can be inhaled in addition to the tidal air. This is called the *complemental* air. By a forced expiration, the lungs can expel about 100 cubic inches of air more than in quiet breathing. This is called the *reserve* or *supplemental* air. There still will be left 100 cubic inches of air, called *residual* air.

343. Action of the cilia.—The motion of the cilia creates an air current in the smaller bronchi, which mixes the incoming fresh air with that already in the lungs, so that

while all the air is not changed with each inspiration, yet there is a free mingling of the fresh with the impure air. The cilia also intercept particles of dust which the nose and pharynx have failed to remove.

344. Rate of breathing.— In health an inspiration occurs with every four heart beats, or about eighteen times each minute, but in exercise its rate may be increased to sixty or seventy times a minute. A baby breathes about forty times a minute. The rate slowly diminishes until, at eighteen years of age, it is the same as in a man.

An inspiration takes about five sixths as long as expiration, but the regularity and force of both inspiration and expiration can be varied indefinitely. Respiration usually goes on without a person's knowledge or thought, yet it is somewhat under the control of the will in talking, blowing, and other actions.

345. Modifications of breathing.— *Coughing* is a forcible expiration in which the closed vocal cords are suddenly blown open with force.

Sneezing is a sudden expiration in which air is driven mainly through the nose.

Blowing is a long forcible expiration in which air is forced in a steady stream through a small opening in the lips.

Laughing and *crying* are each a succession of short expirations. They sound so much alike that it is often impossible to tell which a child is doing.

Sobbing is a succession of short inspirations.

Hiccoughing is a single inspiration caused by a sudden contraction of the diaphragm.

Snoring is a sound produced during inspiration by air passing over the soft palate. It is usually due to air passing through both the nose and the mouth at the same time.

Gaping or *yawning* is a long and deep inspiration and expiration through the open mouth, while the muscles of the throat are strongly contracted.

Sighing is a deep inspiration followed by a sudden relaxation of the muscles so that the escaping air makes a sound.

Choking is a sudden stoppage of the larynx or trachea. When a person is choked, he should lie down upon his face with his head lowest. Slapping his back will aid in jarring the substance loose. If this does not dislodge it, he should be hung head downwards while his back is pounded vigorously. In that position the substance may fall out, while if he sits upright, it may fall in deeper unless it is coughed out.

Suffocation, or *smothering*, is a cessation of breathing caused by shutting off the air either partly or wholly.

Sucking is an inspiratory act, done by depressing the floor of the mouth so as to form an empty space into which anything held between the lips is forced by the pressure of the air.

Spitting is an expiratory act in which the lips are blown open with an explosive noise.

346. Breathing sounds. — In natural breathing, air rushing in and out of the lungs produces a low, blowing sound, distinct from the sound made by the breathing in the nose and throat. The sound of the voice, when transmitted through the chest, has a characteristic quality and produces a vibration of the chest walls. When the chest is struck with the finger, the sound is modified by the resonant quality of the lungs. All these sounds are changed in lung diseases, and give a sure indication of the nature and extent of the disease.

347. Abdominal and thoracic breathing. — When the diaphragm contracts, it forces the abdominal organs downward, making the abdomen more prominent. Breathing by the free use of the diaphragm is called *abdominal* breathing. When the diaphragm remains comparatively quiet, the ribs are compelled to move more freely. Breathing mainly by use of the ribs is called *thoracic* breathing. In men abdominal breathing is greatest, while in women thoracic breathing seems more prominent.

Distention of the stomach and intestine by a full meal, or by gas, interferes with the downward movements of the diaphragm, and compels a greater extent of thoracic breathing.

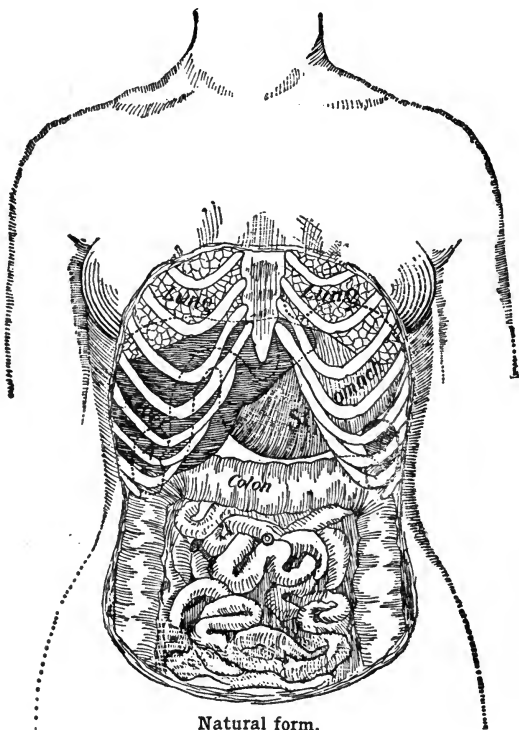

348. Effect of tight lacing. — A person whose waist is laced tightly with corsets cannot breathe in the proper amount of air, but is short of breath and easily fatigued.

Tight corsets also compress the liver and other abdominal organs. In extreme cases the liver becomes divided almost into two parts by the pressure.

349. The respiratory center.—The movements of the chest and diaphragm in breathing are controlled by a small part of the brain situated just above the spinal cord, and called the *respiratory center*. When it is destroyed,

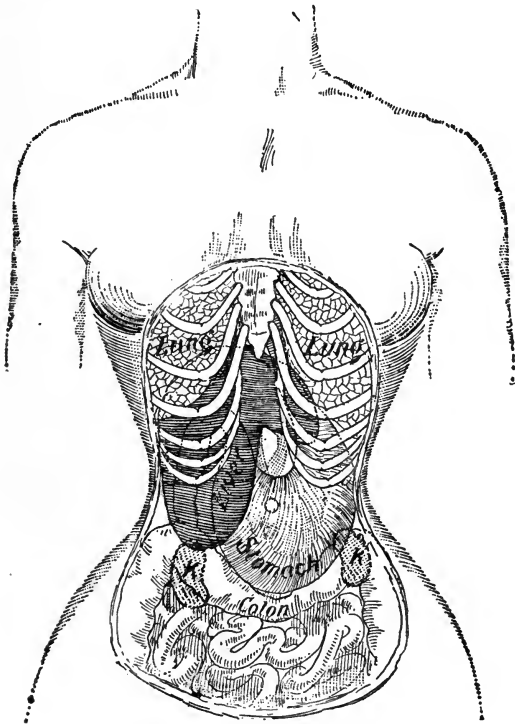

Results of unhealthful dress.

respiration ceases at once, and no power can arouse it again.

Stimulation of the nerves of the body which go to the respiratory center may cause it to send out orders for the respiratory muscles to act. Thus, suddenly throwing cold water on the chest will cause a

contraction of the muscles of breathing which lasts for a few seconds, so that a person cannot catch his breath.

A substance sucked into the trachea irritates the nerves which go to the respiratory center. The center sends back an order to the respiratory muscles to expel the substance by a forcible blast of air. Thus the substance is coughed or sneezed up.

350. Artificial respiration.—The walls of the chest are elastic and quickly return to their natural size when they are relieved of stress. It is possible, therefore, to imitate natural respiratory movements upon a man who has stopped breathing. This

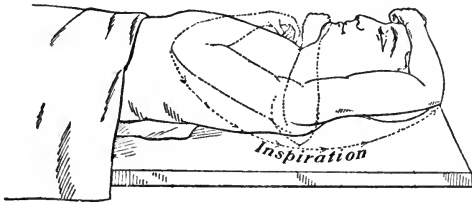

is called *artificial respiration*.

Diagram of artificial respiration, showing inspiration.

The arrows show that the arms are moved outward from the sides of the chest.

By pressing hard upon the chest fifteen or twenty times a minute, a great deal of air will be made to pass in and out of the chest.

A more effective method is to lay the person upon his back, with the head lowest if possible. Standing at his head, draw each arm outward and upward, in a semicircle, away from his body, until they are stretched above his head almost in a line with his body. This raises the chest and

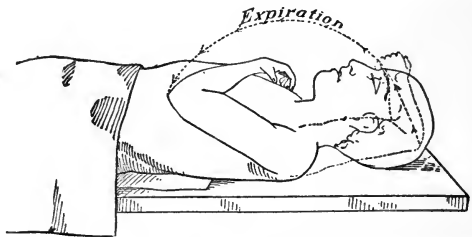

Diagram of artificial respiration, showing expiration.

The arrows show that the arms are carried directly forward until they are pressed hard against the chest.

produces an inspiration. Then carry the arms directly forward and down and press them forcibly against the side of the chest. This produces an expiration. These movements should be repeated about fifteen or twenty times a minute, or at the rate of natural breathing.

If an assistant grasps the tongue and pulls it forward during each inspiration, it will open the larynx and also stimulate the nerves going to the respiratory center.

Every person should know how to perform artificial respiration, for it may be the means of saving a life from drowning or from an electric shock. No one should hesitate to attempt artificial respiration in these cases, for even crude and ignorant attempts will result in the entrance of some air and may save a life.

SUMMARY

1. The lungs are two organs from which the red blood cells obtain oxygen for the use of the cells of the body.
2. Each lung is made of tiny air sacs which communicate freely with the air through the windpipe and nose.
3. Each lung rests upon a curved muscle called the *diaphragm*, and is covered by curved ribs.
4. When the ribs are lifted or the diaphragm depressed, air enters the lungs. This is inspiration.
5. When the muscles relax, the weight of the parts and the elasticity of the lungs drive out some of the air. This is expiration.
6. Inspiration and expiration occur alternately about eighteen times a minute.
7. The movements of the ribs and diaphragm in breathing are controlled by a small part of the brain just above the spinal cord.

8. Artificial respiration can be performed by alternately pulling the arms above the head and compressing them against the chest about twenty times a minute.

DEMONSTRATIONS

81. Each pupil can notice the different movements of his own breathing. At will he can change from abdominal breathing to thoracic breathing, or can use all of the muscles of the chest in taking a very deep inspiration. A tape measure passed around the body just under the armpits will show how the chest increases in size with each inspiration and diminishes with expiration.

82. A small animal should be killed and its chest opened so as to show the lungs and heart in place. Notice the shining pleura, and that at the back part of the chest it leaves the chest wall and covers the lungs. Notice the position of the ribs and diaphragm, and the arrangement and direction of their muscle fibers. (See demonstration 35.)

83. In a recently killed cat or dog the diaphragm can be made to contract by irritation of the nerve called the *phrenic* nerve, which conveys orders for motion from the respiratory center to the diaphragm. There are two nerves, one of which enters the diaphragm near the middle of each side of the arch. Remove the lungs carefully. Then the site of the nerve can be recognized by a slight roughness in the otherwise smooth pleural covering. Pricking or pinching this point will cause a contraction of the diaphragm. (See demonstration 35.)

84. Kill a frog by placing it in a tight jar with a few drops of chloroform. Open its chest and abdomen. Insert a small pointed glass tube into its trachea. The slitlike opening can be found upon the back of the tongue. Blow through the tube to inflate the lungs, and at once tie a string tightly around their base. Remove the lungs and let them dry. Notice the partitions like the cells in a honeycomb, extending a little way into the central cavity. Explain that a man's lung is like a collection of tiny frog's lungs. (See illustration on page 196.)

85. Examine a prepared microscopic specimen of a lung and of the trachea and bronchi. Notice the ciliated epithelium in the trachea and bronchi. Notice that the walls of the air sacs form an irregular network inclosing the large spaces of the air sacs. The specimen will probably show a small bronchus. Notice its thick walls containing some muscular tissue and possibly some cartilage.

86. Show the class how to perform artificial respiration. Have a boy lie upon a desk and go through the movements of carrying his arms above his head and of pressing them against his side again. Do not perform the movements too rapidly and do not press the arms too far backward above the head.

87. The *pharynx* and *palate* are puzzling parts to understand, but are very simple when shown upon a small animal. With a sharp knife and fine saw, divide the head and neck of a small animal through the middle of the nose and backbone. Show that the hard palate and the soft palate divide the nose from the mouth. Show that the pharynx extends upward behind the nose and downward lower than the tongue. Show the position of the tonsils and where adenoid vegetations form.

88. *Cilia* can be shown with cells from a frog's mouth. Gently scrape its roof, removing a drop of slime with some of the epithelial cells. Examine it with the high power of the microscope. The cilia will appear as a fringe in rapid motion. (See demonstration 35.)

REVIEW TOPICS

1. Define *respiration* and state its object.
2. Describe the *nose*, *pharynx*, *larynx*, *trachea*, *bronchi*, *cilia*, *air sacs*, *lungs*, and *pleura*.
3. Describe *adenoid vegetations* and their effects.
4. Give the evil effects of *mouth breathing*.
5. Describe the chest, ribs, and diaphragm.
6. Describe *inspiration* and *expiration*.
7. Give the amount of air used in *ordinary* and in *forced* breathing.
8. Give the action of the *cilia*.
9. Give the *rate* of breathing, and its variation in laughing, sobbing, coughing, hiccoughing, sneezing, gaping, sighing, and snoring.
10. Describe the *sounds* produced by breathing.
11. Describe *abdominal* and *thoracic* breathing.
12. Give the effects of tight lacing.
13. Describe the respiratory center and its action.

320
340 } 2. 2. 2.

CHAPTER XXIII

RESPIRATION OF THE TISSUES

351. Changes in respired air.—The air is composed of about 80 per cent of nitrogen, 20 per cent of oxygen, and $\frac{4}{100}$ per cent of carbonic acid gas. The nitrogen has no effect upon the body, but acts simply by diluting the oxygen. Air which is ordinarily breathed out from the lungs contains 16 per cent of oxygen and 4 per cent of carbonic acid gas, while the amount of nitrogen remains unchanged. Thus, in breathing, the air gains as much carbonic acid gas as it loses oxygen. Expired air is warmer and contains more watery vapor than inspired air, and sometimes contains a trace of a very poisonous organic gas.

352. Blood changes in the lungs.—Every 100 cubic inches of venous blood entering the lungs contain 46 cubic inches of carbonic acid gas, and from 8 to 12 cubic inches of oxygen gas. As it leaves the lungs the same amount of blood contains about 40 cubic inches of carbonic acid gas, and 20 cubic inches of oxygen gas, and it has changed its shade from the dark red of venous blood to the bright red tint of arterial blood. It has also lost a small amount of water and some heat. The essential change which occurs in the passage of blood through the lungs is the exchange of carbonic acid for a corresponding amount of oxygen gas. In health, during quiet breathing, the blood becomes completely saturated with oxygen.

353. Affinity of blood for oxygen.—Blood exposed to

the air takes up oxygen very readily and becomes of a bright red color. Thus, blood as it usually flows from a slight wound, takes up oxygen gas almost immediately and becomes the color of arterial blood, and venous blood is seldom seen. Between the dark color of the venous blood in the veins of the hands, and the brighter pink hue of the surrounding skin due to the capillaries, there is a contrast which is a good indication of the usual difference between venous and arterial blood.

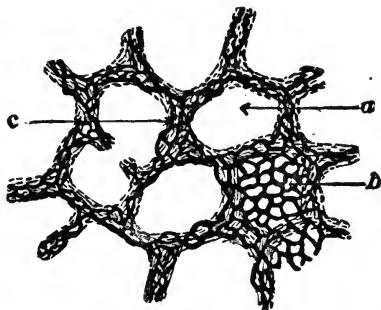

Sketch of a thin slice of a lung, showing the arrangement of capillaries upon the walls of the air sacs ($\times 50$).

- a* interior of an air sac.
b bottom of an air sac covered with capillaries.
c side of an air sac with capillaries.

354. Exchange of oxygen and carbonic acid in the lungs.

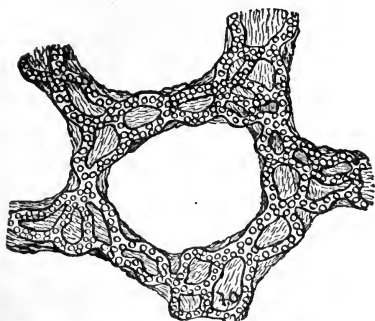

Capillaries upon the sides of an air sac ($\times 200$).

— The blood in the capillaries of the lungs is separated from the air in the air sacs by only the thin walls of the capillaries. Oxygen from the air in the air cells passes through the capillary walls into the blood almost as readily as though there were no walls at all. In the blood the oxygen combines with

the hemoglobin of the red blood cells, and the blood be-

comes of a brighter red color as it gains oxygen. Carbonic acid, which was combined with the alkalis of the blood plasma, passes through the capillary wall into the air of the air sac as easily as the oxygen entered the blood.

355. The skin and stomach as respiratory organs.— Wherever the blood tubes are in contact with the air, absorption of oxygen will take place. In the stomach and intestine the blood tubes are very near the surface, and are in contact with air swallowed with the food. So some oxygen will be absorbed and some carbonic acid gas given off. The skin also absorbs oxygen and gives off carbonic acid gas. In a frog at least $\frac{1}{3}$ of the respiration is performed in this way. In man, about $\frac{1}{200}$ as much respiration is carried on by the skin, stomach, and intestine as by the lungs.

356. Respiration of the cells of the body.— After leaving the lungs, the blood is distributed through the arteries,

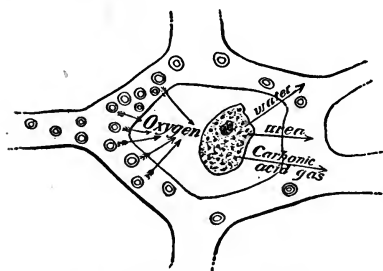

Diagram of the respiration of cells.

and enters the capillaries of the body. As it enters the capillaries it contains the same amount of gases as when it left the lungs; that is, each 100 cubic inches of blood contains 40 cubic inches of carbonic acid gas and 20 of oxygen. As it leaves the

capillaries, it contains the same amount of the gases as the venous blood which enters the lungs; that is, each 100 cubic inches contains 46 cubic inches of carbonic acid gas and 12 of oxygen. The exchange in the capillaries balances the exchange in the lungs.

When a piece of flesh is put into a dish of blood, oxygen

will leave the red blood cells and combine with the cells of the flesh. In a similar way oxygen leaves the red blood cells in the capillaries and, passing through their thin walls, unites with the cells of the body, producing carbonic acid gas, water, and urea. The water and urea go back to the blood and are thrown off by the kidneys. The carbonic acid gas passes through the capillary wall into the blood and unites with the alkalies of the plasma. This goes on in every capillary and cell of the body and constitutes the real act of respiration. The lungs and red blood cells are only devices for carrying oxygen to the deep cells of the body.

357. Oxidation of sugar and fat. — Neither sugar nor fat becomes a living part of the cells of the body, but after being absorbed both are oxidized at once and furnish about three times as much heat and energy as the albumin, which forms a part of the cells. But oxidation in the body is a living process, and requires the operation of living tissues. So it is unlikely that it occurs in the blood stream. As sugar is absorbed, the cells of the liver take it into their own substance, and probably oxidize it there. In the same way the fat is probably taken up by the epithelial cells of the air sacs of the lungs and oxidized. In each case the heat is distributed through the whole body by the blood.

358. Respiration a continuous process. — When the breath is held, the oxygen in the lungs and that carried by the red blood cells is sufficient to supply the body for only about half a minute. By the end of that time all the blood becomes venous and a great shortness of breath is felt.

Oxygen passes from the lungs through the blood tubes to the cells of the body with great rapidity, so that by a few deeper breaths enough extra oxygen is taken up by the red blood cells to relieve shortness of breath caused by their lack of oxygen.

359. Amount of oxygen used daily.—The amount of oxygen used in the body is constantly varying. During muscular exertion greater power is required than when the body is at rest. To keep up the increased power, more oxygen must leave the blood and unite with the muscle cells. During sleep less oxygen is needed, but the average amount used each day is fairly constant.

It is a simple example in arithmetic to calculate how much oxygen the red blood cells usually carry.

18 = no. of respirations per minute.

30 = no. of cubic inches of air in each inspiration.

540 = no. of cubic inches of air inspired each minute.

60
32400 = no. of cubic inches of air inspired each hour.

.04 = per cent of air which enters the red blood cells as oxygen.

1296 = no. of cubic inches of oxygen entering the blood each hour.

1296 ÷ 1728 = 0.75 = cubic feet of oxygen entering the blood each hour.

0.75

1.2 = ounces weight of a cubic foot of oxygen.

0.9 = ounces of oxygen entering the blood each hour.

24

21.6 = ounces of oxygen entering the blood each day.

Allowing two or three ounces more for extra exertions, about 25 ounces of oxygen enter the body each day. This is about the amount needed to oxidize the food which a man usually eats.

The amount of carbonic acid given out is about the same as the amount of oxygen taken in, if it is measured in cubic inches. But since the carbonic acid is heavier, it amounts to about 30 ounces a day. About 20 ounces of water are also breathed out each day.

360. Effect of exercise upon the amount of oxygen absorbed.—In quiet breathing each red blood cell is loaded with oxygen to its full capacity. During muscular exertion the heart beats more forcibly and faster, driving the red blood cells more rapidly, and thus, in a given time, more oxygen will be carried. But when the cells are shot

through the capillaries too rapidly, there is no time for either giving or receiving oxygen, and the body may be actually starved of oxygen. So the average amount of oxygen which the blood can carry is found to be about 25 ounces daily.

It is possible to educate the respiratory muscles so that during physical exertion they act more regularly and strongly. As a result, the lungs are expanded more, and a greater area of capillaries is exposed to the air. The heart also may be trained to restrain its violent action, so that the blood is not shot through the capillaries of the lungs too rapidly to take up oxygen. An athlete trains his body so that it can absorb more than 25 ounces of oxygen daily, and thus he can put forth a greater amount of exertion. Such a person is said to be *long winded*.

361. Causes of shortness of breath. — The sensation of shortness of breath is usually due to a deficiency of oxygen in the blood which circulates through the respiratory center. The blood contains too little oxygen when an extra amount of oxygen is used during great physical exertion. At first, the heart pumps the blood faster so that it carries more oxygen in a given time, but when the blood is pumped very rapidly, the red blood cells are shot through the lungs so quickly that they cannot obtain the necessary oxygen. When, as in heart disease, the blood is pumped too slowly, only a small amount of oxygen will be carried through the respiratory center, and there will be continuous difficulty in breathing. Shortness of breath is often the first sign of heart failure. After severe hemorrhage there are too few red blood cells to carry the full amount of oxygen, and so shortness of breath will be felt. Death by bleeding is due to suffocation and lack of oxygen. In the disease called *anemia* there are too few red blood cells to carry oxygen, and so there is shortness of breath on exertion. When the larynx or the trachea is compressed or obstructed, as in choking, or when the smaller bronchi are filled with mucus, as in bronchitis, oxygen is prevented from entering the blood, and the respiratory center feels a great shortness of breath.

362. Oxygen inhalations. — Since the red blood cells are loaded with oxygen to their full capacity as they leave the lungs, they could absorb no more even if it were inhaled in a pure form. When there is a shortness of breath during disease, pure oxygen is sometimes inhaled to take the place of the diluted oxygen of the air. When the lack of oxygen is due to a diminished number of red blood cells, or if the blood flows too slowly to carry enough oxygen, inhaling oxygen can do no good, for the blood cells leaving the lungs are already loaded with it. The poisons of certain diseases may cause the arteries to contract and the heart to beat with great force and rapidity. Then the blood cells may move so quickly that they have no time to take up oxygen from the lungs. Neither rest nor violent inspiratory efforts will relieve the resulting shortness of breath, but more oxygen may reach the blood cells if it is inhaled in a pure form.

If there is an obstruction to the entrance of air into the lungs, more oxygen may pass the obstruction if it is inhaled in an undiluted form. When the larynx or trachea is obstructed by a membrane in diphtheria, or when the small bronchi are filled with mucus, as in bronchitis and pneumonia, then the inhalation of pure oxygen may be of great benefit.

363. Asphyxia. — When the breath is held, a feeling of discomfort comes on in about half a minute, which soon becomes great distress. If a person is prevented from taking a breath, he will become unconscious in a few seconds, but will make great inspiratory efforts for a minute or more. There will be convulsions, and the face will turn purple, for all the blood is venous. Death will take place in less than five minutes. This is called *asphyxia*. At any time before death actually takes place life can be restored by artificial respiration.

364. Drowning.—Drowning is a form of death by asphyxia, but is complicated by the entrance of water into the lungs.

The treatment of drowning is simply to perform artificial respiration. In order to do it, it will be necessary to remove the water from the lungs. This can be done by turning the person upon his face and forcibly compressing his back. It will be still better to suspend him head downwards for a few seconds, or standing astride him to raise him up and down about twenty times a minute by grasping him about the lower part of the chest. This performs artificial respiration and lets out the water at the same time.

The person's limbs should be rubbed vigorously toward the heart and kept warm by hot water bottles. No time should be lost by carrying him to a building, but artificial respiration should be done on the spot. Even if the person has been in the water half an hour or more, it is possible to restore life.

365. Electric shock.—A shock of electricity kills by overwhelming the nervous mechanism which controls the heart and lungs. A shocked person is unconscious, and apparently lifeless, and yet life may be restored by artificial respiration. It should be done at once, and continued for a long time if life is not quickly restored.

366. Effect of alcohol upon the lungs.—Alcohol partially paralyzes the arteries of the body so that they dilate and permit a larger quantity of blood to pass through. Thus, the capillaries of the lungs may be distended with the rest. Then they may partly fill the air sacs so that less air can enter. If the distension continues for some time, the walls of the capillaries may thicken so that oxygen will pass through them less readily. The walls of the air sacs themselves may become thickened, and the exchange of

oxygen and carbonic acid impeded. This effect may be produced by continuous moderate drinking.

367. Alcohol interferes with the respiration of the cells. — Alcohol is quickly absorbed from the stomach and intestine and as quickly disappears. After it is taken, little or no alcohol, or any substance like alcohol, or any substance containing so little oxygen as alcohol, can be found in any waste of the body. Hence the inference is that it must be oxidized, although the exact point and the manner of its oxidation may not be known. But the evidence for its oxidation is the same as that for the oxidation of sugar.

Every ounce of alcohol requires nearly two ounces of oxygen to oxidize it fully. Taking twenty-five ounces of oxygen gas as the amount used in a day, there will be only one ounce used in an hour. So to oxidize an ounce of alcohol takes an amount of oxygen equal to the whole supply of the body for two hours. Three or four drinks of whisky contain this ounce of alcohol. If this amount is drunk, there will soon be a lessened action and a narcotic effect throughout the body, due mainly to the lack of oxygen. A noticeable degree of uncertain action is called *intoxication*.

Using alcohol in the body is like burning kerosene in a coal stove. By taking great care a little kerosene can be made to give out some heat from the stove, but the operation is dangerous. Some people seem to oxidize alcohol within the body with but little harm; but they run great risks of doing themselves harm, and the result is not nearly so good as if they had used proper food.

368. Poisons produced by alcohol. — When too little oxygen enters the draft of the stove, the wood is burned imperfectly, and there are clouds of smoke and irritating gases. So, if oxygen goes to the alcohol and too little reaches

the cells, instead of carbonic acid gas, and water, and urea being formed, there are other products, some of which are exceedingly poisonous and which the kidneys handle with difficulty. The poisons retained in the circulation never fail to produce their poisonous effects, as shown by headaches, clouded brain, pain, and weakness of the body. The word *intoxication* means, "in a state of poisoning." These poisons gradually accumulate as the alcohol takes oxygen from the cells. The worst effects come last, when the brain is too benumbed to judge fairly of their harm. It is not true that alcohol in a small amount is beneficial. A little is too much, if it takes oxygen which would otherwise be available to oxidize wholesome food.

369. Effects of tobacco.—Tobacco smoke contains the same kind of poisons as the tobacco, with other irritating substances added. It is usually sucked into the mouth and at once blown out again, but cigarette smoke is commonly drawn into the lungs and afterwards blown out through the nose. It is irritating to the throat, causing a cough and rendering it more liable to inflammation. If inhaled into the bronchi, it produces still greater irritation, and the vaporized nicotine is more readily absorbed as the smoke is inhaled the more deeply. Cigarettes contain the same poisons as other forms of tobacco, and often contain other poisons which are added to flavor them.

370. Respiration in birds.—The lungs of all land animals are like man's lungs, and the process of respiration is the same. The lungs of birds are fixed in the upper part of the thorax, and in addition they are provided with two smooth bags, each somewhat larger than the lung. Each bag connects with the air sacs of the lung, and also with the interior of the larger bones. Respiration can occur in the bags and bones as well as in the lungs.

The air bags are expanded with air during flight, and thus the body is made lighter in proportion to its size, in order that the bird may fly more easily.

371. Respiration in water animals.—Some water animals, such as the porpoise and the whale, possess lungs like

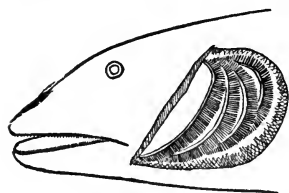

Gills of a fish.

land animals, and are compelled to come to the surface of the water in order to breathe, but fish have a special apparatus so that they can use the oxygen which is dissolved in water. On each side of a fish's head is a slit-

like opening reaching from the interior of the mouth to the surface of the body. In each opening are four half circles of limber bone. From the back of each circle a row of thin fingerlike plumes projects, so that it looks like a red feather with plumes only on one side. These half circles are the *gills*. Each plume contains a blood tube which is separated from the water by a very thin wall. The fish forces the water through his mouth and out between the gills, and the oxygen contained in it readily passes through the thin wall of the blood vessel into the red blood cells.

372. Respiration in a frog.—A frog in the tadpole form is provided with gills which project into the water from its neck, but when it becomes a perfect frog the gills disappear and lungs are formed. But the frog's skin is able to absorb oxygen and to give off carbonic acid gas about one eighth as rapidly as the lungs.

373. Respiration in insects.—In insects from three to nine tubes extend into each side of the abdomen and divide into small branches, but do not communicate with any cavity. The fluid which answers for the insect's

blood comes in contact with the surface of the tubes and absorbs oxygen from the air in them. As they possess no hemoglobin or red blood cells, oxygen is simply dissolved in the blood; but owing to the small size of their bodies, this is sufficient for their use.

374. Respiration in shellfish. — Shellfish, such as oysters and clams, have gills like fringes along their front edges. The gills are covered with cilia which cause currents of water bearing food and air to flow through the shell.

375. Respiration in plants. — A plant also breathes. While it uses heat from the sun in the manufacture of starch from the carbonic acid gas and water, yet for its own movements it requires a production of heat within itself. In order to climb a pole and unfold its flowers, a vine requires power which is furnished by the oxidation of its own substance. At the height of the flowering season the temperature of the plant is raised slightly above that of the surrounding atmosphere, and carbonic acid gas is given off. In every case the heat and power is furnished by oxidation of some of the plant's own substance, but the amount of carbonic acid gas given off is insignificant in comparison with the amount of carbonic acid gas which the plant uses as food. A little oxygen is absorbed by the leaves, but it is small in amount compared with what is given off by the plant.

SUMMARY

1. As blood passes through the capillaries of the lungs it gives carbonic acid gas to the air and takes about the same amount of oxygen from the air.
2. As blood passes through the capillaries of the body it gives up oxygen to the cells and takes carbonic acid gas from the cells.

3. The exchange in the two sets of capillaries balances.
4. Within the living cells the oxygen unites with the albumin, fat, and sugar, producing carbonic acid gas, water, and urea.
5. About twenty-five ounces of oxygen are used daily in oxidizing the body.
6. When not enough oxygen is present within the body, there is a shortness of breath.
7. Alcohol often causes distension and thickening of the capillaries and of the walls of the air sacs, so that oxygen passes through them less readily.
8. The alcohol of three or four strong drinks of liquor uses as much oxygen as would supply the whole body for two hours.
9. As a result of taking oxygen from the cells of the body, the cells act in an uncertain manner, which is called intoxication.
10. Tobacco smoke irritates the air passages. It contains nicotine, which can enter and poison the body.
11. All kinds of animals and plants breathe in oxygen and give off carbonic acid gas.

DEMONSTRATIONS

89. With a glass tube, blow air through some limewater, and notice that it grows milky, showing the presence of carbonic acid gas. Breathe upon a cold glass and notice that moisture collects from the breath. Call attention to the fact that bad odors in the breath are due to decayed teeth, a coated tongue, or foul stomach, or possibly to a dirty nose.

90. The change in color from venous to arterial blood can be illustrated by cutting into a thick slice of beef. At first the cut surface is dark and purplish, and of the color of venous blood. But in a few seconds the blood in the meat absorbs oxygen from the air and becomes bright red in color like arterial blood.

91. With two needles tease apart a bit of gill from a shellfish and examine it with the microscope for the waving cilia.

92. Show a fish's gills and if possible a tadpole's also. Wigglers, the young of mosquitoes, can be found in rain barrels, and are very interesting. Each wiggler has a breathing tube near the hinder part of its body. The insects wiggle about in the water and at intervals come to the surface and thrust their breathing tubes above the surface to get oxygen directly from the air.

REVIEW TOPICS

1. Give the changes occurring in the air within the lungs.
2. Give the changes which occur in the blood within the lungs.
3. Show that the blood carries oxygen.
4. Show that the skin and stomach are respiratory organs.
5. Show that the cells of the body take oxygen and give off carbonic acid gas.
6. Show that the blood carries carbonic acid gas.
7. Show that respiration is a rapid and continuous process.
8. Calculate how much oxygen is used daily and how much carbonic acid gas is given off.
9. Show why a person becomes *long winded* by training.
10. Give some causes of shortness of breath.
11. Tell when and why inhalations of pure oxygen are of benefit.
12. Give the effects of alcohol upon the walls of the air sacs.
13. Show how alcohol affects the respiration of the cells.
14. Show how alcohol causes poisons to develop within the body.
15. Give the effects of tobacco upon the air passages.
16. Show how respiration is modified in birds, in fish, in frogs, in insects, and in shellfish.
17. Explain the respiration of plants.

CHAPTER XXIV

THE AIR AND VENTILATION

376. Composition of air.—Every 100 parts of air are composed of about 20 parts of oxygen and 80 parts of nitrogen: $\frac{4}{100}$ per cent of the air is carbonic acid gas. Air contains water in varying amount. Some dust particles are always floating about, and also a few living germs of plants like those producing mold and yeast. These substances are found in all air, and none are harmful.

377. Ozone in the air.—There is a form of oxygen called *ozone* which is much more active than common oxygen. It can be made by passing a strong current of electricity through a tube of oxygen. During thunderstorms some is formed, which imparts a peculiar odor and exhilarating property to the air. Some is formed in pine forests, and to it the beneficial effects of the forests upon consumptives may be due. It is never found in any great amount in the air.

378. Argon.—It was discovered in 1894 that the part of the air supposed to be pure nitrogen contains a gas hitherto unknown, to which the name *argon* has been given. One per cent of the air is argon. Like nitrogen, it cannot be made to unite with any substance directly from the air, and so both act simply to dilute the oxygen. But, unlike nitrogen, it does not form a chemical combination with anything at all, but is always found simply mixed with the

air, or with a few other substances. Its discovery has not modified our ideas of the physiological effects of the air.

379. Dust in the lungs. — If the dust in the air is small in amount, it adheres to the moist surface of the nose and pharynx, and does not enter the trachea. If some enters the trachea, it becomes entangled in the cilia of the epithelial cells and is forced back towards the mouth and then coughed out. If the air is very dusty, some dust will enter the air sacs. Then the dust particles will be carried by the lymphatics to the nearest lymph nodes, where they will be deposited and remain harmless. But the greatest danger from dust is that many of the particles may consist of disease germs (p. 418).

380. Occupation diseases. — Even though the lymph nodes take care of inhaled dust, after a while the continuous irritation of the hard particles injures the delicate lining of the bronchi and air sacs, and causes bronchitis or asthma or pneumonia. Tool grinders are especially liable to the trouble, for the fine particles of stone and steel which fly off in their work and are inhaled, cannot be taken up by the lymphatics. Potters, miners, flax workers, and pearl button makers are all subject to lung troubles to a greater degree than workers in a dustless atmosphere. Those who work with quicksilver or phosphorus are liable to inhale the fumes and be severely poisoned.

381. Amount of oxygen needed to support life. — When inspired air contains less than 20 per cent of oxygen, a shortness of breath comes on, which is in proportion to the lack of oxygen. A candle will not burn in air containing less than 17 per cent of oxygen, while air containing only 15 per cent of oxygen will support life, but there will be great shortness of breath. In old wells and cellars oxygen is often replaced by carbonic acid gas, and men have been suffocated in them. A simple test of the safety of entering them is to lower a lighted candle into the suspected place. If it burns, there is surely enough oxygen to support respiration. When the amount of oxygen is diminished to ten per cent, animals die in a few moments with all the symptoms of suffocation.

382. Rarefied air.—Every square inch of surface, including that of the body, sustains a weight of fifteen pounds of air, but it is balanced by an equal pressure of air inside the body, in the lungs and stomach and other cavities, and so it is not felt. At high elevations there is less atmosphere pressing from above, and so the air expands and becomes lighter. Then a lung full of air will contain less oxygen. At a height of three and a half miles the air is only one half as dense as at the surface of the earth, and at the height of five miles it is almost impossible to breathe enough oxygen to sustain life. The lessened pressure upon the body disturbs the flow of blood, especially in the brain, and produces dizziness and fainting.

In mountainous regions the air is lighter and holds less moisture than in lower regions. It is also purer, for it is removed from the contamination of cities which crowd the lower waterways. So those regions are favorable for those suffering with lung diseases such as consumption. Probably a still greater benefit is derived from the respiratory exercises and the full expansion of the lungs which are necessary in order to obtain sufficient oxygen.

383. Effect of increased pressure of air.—In working under water in laying deep foundations for buildings, a large box called a *caisson* is sunk to the bottom, and into it air is forced so as to keep out the water. Men work within the caisson subjected to double or triple the natural pressure of air. Although more air is inspired with each breath, the blood does not seem to take up more oxygen than usual; but the increased pressure of air upon the arteries and veins produces great disturbances of the circulation. It is impossible to remain in the caisson longer than an hour or two at a time. In leaving the caisson, the air pressure must be diminished as slowly as on entering, so as to permit

the liberated gases to expand slowly. The ear drums could be easily ruptured by a quick change in pressure. Sometimes the pressure causes a severe injury of the spinal cord.

384. Effects of carbonic acid gas.—Carbonic acid gas itself has very little harmful effect upon the body. When air containing one fourth its bulk of carbonic acid gas is inhaled, the air sacs soon contain more of the gas than is found in the blood. Then carbonic acid gas is no longer given off, but remains in the blood and air sacs, and prevents the entrance of oxygen. Shortness of breath, unconsciousness, and death soon occur, caused mainly by the displacement of the oxygen. Carbonic acid has been used to produce insensibility during surgical operations but its effects cannot be controlled, and its use is unsafe.

When many persons are confined in a small room, the oxygen is speedily used up, and carbonic acid gas takes its place. When the amount of oxygen is diminished to ten per cent, death will occur, caused rather by the lack of oxygen than by the presence of the carbonic acid gas or other substances in the expired air. But discomfort will be felt long before the oxygen is diminished to an appreciable degree.

385. Foul air.—Besides the carbonic acid gas, the expired air contains a greater or less quantity of water and of foul-smelling vapors. Odors are constantly given off also by the skin of the most cleanly persons. In the air of a closed room in which several people have been for some time, there is a characteristic odor which belongs to man, just as certain odors are peculiar to different lower animals. These odors are very oppressive. They cause sickness in sensitive persons mainly because of their unpleasantness. This effect passes off when pure air is

breathed. The heat of a closed room greatly intensifies the effect of the foul air.

386. Cause of bad effects of foul air. — No one thing can be found in stuffy air to account for all the bad feelings which it produces. The diminution of oxygen is too slight to produce noticeable effects, but the combination of heat and foul odors is very oppressive to persons not accustomed to them, while the carbonic acid gas tends to cause drowsiness and dullness of mind. Those who live in a foul atmosphere continually are usually too poor to buy nourishing food, and too busy to take exercise in the open air, and, moreover, are greatly overworked. These causes produce even more ill health than the foul air.

387. Bad odors. — Decaying matter gives off bad odors. Many animals and vegetables have an offensive smell, and in many manufactures foul odors are continually poured into the air. These odors in the air are seldom harmful, yet the source of the odors is usually dangerous to health, and the odors are given off as a warning. It is nearly always true, that harmful things have an offensive smell and taste. So a bad odor reveals a decaying body which might poison a well, or a disease which might be communicated to others.

Since odors are only signs, the danger is not past if only the odor is destroyed. Ammonia, carbolic acid, or perfumery may mask the odor, but they only obscure the source of danger.

388. Sewer gas. — Sewer gas is exceptionally offensive and penetrating. The odor is not especially harmful, but disease germs which are emptied into the sewer from sick rooms are easily carried with the gas. Usually the strong odor betrays the leak in the pipes before the germs have gained an entrance.

389. Cellar air. — Cellars are apt to be closed, so that little fresh air and light can enter. Decaying vegetables and other substances may accumulate in the corners. This makes a breeding place for disease germs, which may be carried up through the floors into living rooms above. A cellar should be kept dry, clean, and well aired.

390. Malaria. — Malaria, chills and fever, fever and ague, or intermittent fever, as the disease is variously called, is caused by germs that grow within the bodies of certain kinds of mosquitoes, and are left beneath the skin when the insects bite a person. In order to rid a place of malaria, the malarial mosquito must be exterminated. All mosquitoes spend the first part of their lives in stagnant water as wigglers, and may be destroyed by draining the marshes and stocking the pools with fish which eat the wigglers.

391. Night air. — There is a popular belief that during the night the air contains some harmful substance which disappears during the day. But the air of the early evening, which is supposed to be the worst air of the day, has been purified by hours of sunshine, while the air of early morning, which is supposed to be the best of the day, has been exposed to hours of the noxious influences of darkness. So the belief is a contradiction in itself.

392. Contamination of air by fire and light. — In addition to the impurities produced by breathing, the air of inhabited rooms is further rendered impure by fires and lamps. A tallow candle will consume half as much oxygen in a given time as a man. A lamp burning a pint of oil in an evening uses as much oxygen, and gives off as much carbonic acid, as a man gives off during a whole day. A stove uses an immense amount of oxygen, but the gases pass up the chimney. Candles and lamps often pour bad-smelling gases into the air.

393. Coal gas. — When coal is heated, it gives off a gas called *carbonic oxide*. Carbonic oxide is the main part of illuminating gas, and in a stove, burns with a blue flame. It is extremely poisonous when breathed. It unites with the hemoglobin of the red blood cells and destroys their power of carrying oxygen. Gas from a smoking

coal stove or a leaking gas pipe may smother a whole family while they are asleep.

In treating a case of poisoning by gas, an abundance of fresh air should be admitted, and artificial respiration should be performed.

394. Germs of disease in foul air. — Disease germs may be breathed into the air. If the air of a room smells stuffy, it is a hint that the germs as well as the stuffy odors may be accumulating. Lung diseases are especially frequent among those who work in close rooms. The germs of "colds," scarlet fever, and all other "catching" diseases, are also likely to accumulate in a close room. Sick persons often breathe out the germs of disease, which may reënter the body and continue the disease. Moreover, every discomfort retards recovery, so in sick rooms and hospitals a continuous supply of fresh air is especially necessary, while in every room the air should be changed often enough to prevent the stuffy odor from developing.

395. Consumption. — Tuberculosis of the lungs, or consumption, is an infectious disease, caused by the growth of living germs within the lungs. A person suffering with consumption is continually giving off the germs in the secretions from his air passages. His handkerchief contains millions of them. While moist they remain on the handkerchief or clothes, but when dry they may float through the air, and when inhaled may produce the disease. A consumptive is always a menace to other occupants of a room, especially if he does not exercise great care with the secretions from his nose and mouth (p. 392).

396. Ventilation. — Continually replacing the impure air of a room with fresh air is *ventilation*. Nowadays, with air-tight rooms and closed stoves, openings need to be provided for the exchange of air. When, by breathing, the quantity of carbonic acid gas in the air is increased by one half its natural amount, other substances have also entered the air, so that it begins to be stuffy. When the

quantity of carbonic acid gas is doubled, the air is markedly oppressive. If the carbonic acid gas is increased to three times its natural amount, the air is too oppressive for comfort, and may contain enough germs of disease to be dangerous to health.

397. Computation of amount of fresh air. — About $\frac{4}{100}$ per cent of fresh air is carbonic acid gas. When $\frac{2}{100}$ per cent more of carbonic acid gas has been added to the air, the air begins to be stuffy and unfit for use. Suppose there is an air-tight room twenty feet square, and ten feet in height, and in it one man is living; the room will contain 4000 cubic feet. $\frac{2}{100}$ per cent of 4000 cubic feet is $\frac{8}{10}$ of a cubic foot, which is nearly the average amount of carbonic acid gas breathed out by the man each hour. Thus in an hour a man renders 4000 cubic feet of fresh air stuffy. In reckoning the amount of fresh air to be admitted to rooms, 4000 cubic feet per hour is the smallest amount which can be safely allowed. Therefore, if only one person breathes the air of a room twenty feet square, and ten feet high, the air needs to be wholly renewed each hour, and yet it contains enough oxygen to last a week. Fresh air is needed when the air of a room smells stuffy to a person coming from pure air.

398. Natural ventilation. — When air is heated it expands so as to fill more space. While a cubic foot of air at a temperature of 32° F. weighs about 1.2 ounces, at 80° F. it weighs about 1.1 ounces. So heated air, being lighter, tends to rise. The air is slightly warmed in breathing, and so tends to rise to the ceiling, while the cool air which enters the room remains near the floor. So the floor is usually cooler than the ceiling. If an opening is made near the ceiling, and another near the floor, the warm air of the breath will naturally pass out at the upper opening, and the cool fresh air will enter the lower opening. If only a few persons are in a room, the openings about windows and doors may be sufficient without special ventilation. If many persons are together

in a room, the natural cracks and openings are not sufficient, but other openings must be made.

399. Methods of ventilation. — In ventilation a perceptible current of air must be avoided, for many people easily take cold when a single part of the body is cooled

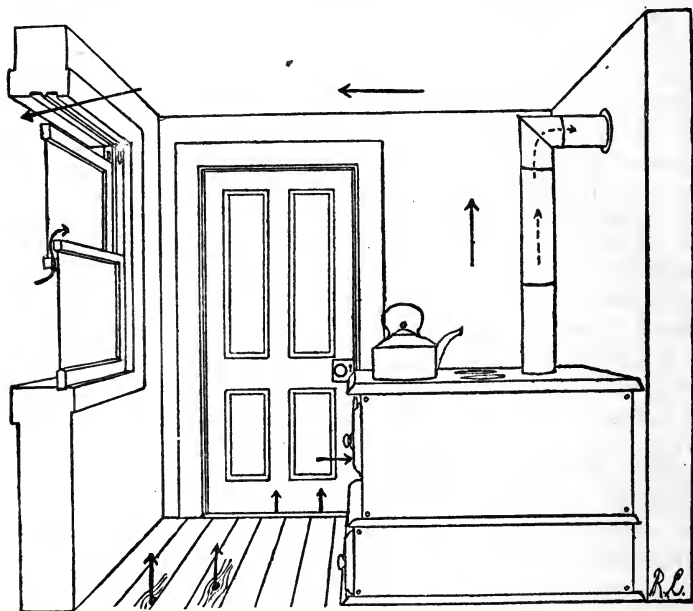

Diagram of the natural ventilation of a room.

The arrows indicate the direction of the air currents.

as by a draft. The air of a room can be changed only three times an hour without producing noticeable drafts throughout the room.

Many devices have been used to secure an even distribution of the incoming fresh air. The simplest is to lower the upper window sash. Warm air will pass out above the upper sash, while the cooler fresh air will enter between the two sashes, and will be given an upward direc-

tion toward the warmer air of the ceiling. There it will become warm, and finally will spread through the room like a gentle shower, instead of in a rushing stream.

A modification of the same idea is to raise the lower sash a few inches and insert a narrow board in the lower opening, so that a space is left between the sashes for the entrance of fresh air. The opening for fresh air may be through the floor under the stove, and thus the air will be heated as it enters the room. An open fireplace produces an upward current of air. An opening into the chimney flue near the ceiling will carry off much of the foul air.

In many churches a small part of the window is hinged so that its top can incline inward. If the window is placed about two thirds of the way between the floor and ceiling, the warm air will pass out above the window, while the cool, fresh air will enter below it. The inclination of the window will cause the air to flow toward the ceiling at first, where it will be warmed and scattered so that it cannot produce drafts upon the heads of the listeners. The addition of an opening in the center of the ceiling for the escape of the warm air forms an efficient mode of ventilation.

Hot air registers both heat and ventilate a room, if care is taken to admit fresh air to the pipes. The hot air passes up from the furnace because it is lighter than cold air. An opening in the window or into the chimney is needed to allow the air of the room to escape, so that the warm fresh air can enter.

Since on a cold day the air inside a room is much warmer than the air outside, a current of air will rush through every crack, so that good ventilation will be secured by a very small opening. Since on a warm summer's day the air inside and outside is nearly of the same temperature, large openings are necessary to effect the change of air.

400. Forced ventilation. — In large buildings, such as factories and theaters, warm fresh air is forced into the rooms by rotary fans, and the impure air escapes through openings in the ceiling. Thus the amount of heat and air admitted can be exactly regulated.

Another way of ventilating large houses is to suck out the impure air by rotary fans, while fresh warm air is admitted through small openings near the floor, thus preventing drafts. This method is being adopted in large buildings to the exclusion of other methods.

401. Filtration of air. — In forced ventilation the air is conducted through a large box, which has partitions arranged so as to

break the air current and allow the dust to settle. In some, the air is passed through a layer of cotton. Cold air contains less moisture than warm air, and unless the air is given more moisture before it is sent to the rooms, it will be very dry. So a pan of water should always be kept inside the air box of a furnace.

402. Schoolroom ventilation. — Children are especially susceptible to unhealthful surroundings, and the air of a schoolroom, in which they spend the greater part of the day, should be kept pure. Pure air means clearer brains and better lessons, and may determine whether or not a child shall gain a sufficient knowledge to assure his success in life. In every half day of school it is well to allow a short recess in which windows and doors can be thrown wide open and the pupils sent out to get deep breaths of oxygen during play.

The upper sashes of all the windows on the side of the schoolroom away from the wind can be kept open a space so as to produce a gentle outward current of foul air.

If the upper sashes cannot be lowered, the lower one can be raised and a board inserted under it so that the only opening left is between the two sashes.

If registers or special means of ventilation are provided, they should be watched and regulated according to the needs of the air.

403. Purification of the atmosphere. — Although it is continually receiving impurities, the atmosphere as a whole never becomes foul, for the process of purification never ceases. First, the wind scatters the impurities to a height miles above our heads and over the seas to arctic and uninhabited regions, and thus dilutes the impurities. Second, rain washes out dust and germs and soot, and foul gases, and carries them into the earth. Third, sunlight destroys living germs floating in the air, and dries up stagnant sources of impurities. Fourth, plants, both on land and in the sea, absorb carbonic acid gas and restore the oxygen to the air. By these means the composition of the air is kept always the same.

SUMMARY

1. Air is essentially oxygen diluted with four times its volume of nitrogen.
2. When the amount of oxygen is diminished there is shortness of breath.
3. Exhaled carbonic acid gas is not poisonous in itself, but if present in great amounts it may keep oxygen out of the lungs.
4. Foul-smelling vapors, carbonic acid gas, moisture, and the contamination by fire and lights make the air of crowded rooms oppressive.
5. Coal gas inhaled may unite with the hemoglobin in the red blood cells so that they will not carry oxygen.
6. The main thing to be feared in close air of crowded rooms is the disease germs which may be breathed into it.
7. The air of a room should be changed often enough to allow 4000 cubic feet of fresh air to each person each hour.
8. Breathed air is warm, and tends to rise and pass out of cracks and openings in the upper part of the rooms, while cold, fresh air enters by lower openings.
9. In large buildings the foul air is either forced or drawn out by rotary fans, and fresh warmed air enters to take its place.
10. The atmosphere is purified by winds, rain, sunlight, and plants.

DEMONSTRATIONS

93. The harmlessness of carbonic acid gas can be illustrated by soda water, which is water in which a large amount of the gas is held under pressure. Open a bottle and inhale the liberated gas. Notice its pungent odor and taste.

94. Hold a candle or lighted match near each crack of the room and notice that usually the flame is blown towards the inside from cracks near the floor, while it is blown outward in cracks higher up.

95. Clap two blackboard erasers together to make a small cloud of dust, and watch the movements of the particles in a ray of sunlight, so as to detect the direction of the air currents in the room.

96. Show methods of ventilation by lowering the upper sash; by raising the lower and inserting a board in the opening. Show and explain the methods of ventilation adopted in the school.

REVIEW TOPICS

1. Give the composition of the air.
2. Describe ozone; argon; nature's method of removing dust from inspired air; and the dangers of inhaling dust in certain trades.
3. Tell how much oxygen is needed in the air to sustain life, and give a simple test to determine whether sufficient is present.
4. Give the effects of rarefied air, and air under increased pressure.
5. Give the effects of carbonic acid gas.
6. Describe foul air and its effects.
7. Discuss the meaning and the effects of bad odors; of sewer gas; of night air; and of cellar air.
8. Describe *malaria*.
9. Show how fire and lights contaminate the air.
10. Describe coal gas poisoning.
11. Show that foul air may contain disease germs.
12. Calculate how much fresh air should be admitted into a given room for a given number of persons.
13. Describe how ventilation naturally goes on, and tell some ways of assisting nature in ventilation.
14. Tell how a schoolroom may be ventilated.
15. Tell how the atmosphere is purified.

CALIFORNIA COLLEGE of PHARMACY

CHAPTER XXV

HEAT AND CLOTHING

404. Temperature of the body. — During health a man's body has a temperature of $98\frac{1}{2}^{\circ}$ F., which does not change either upon the warmest day in summer or the coldest day in winter. The body is warmed by the oxidation of its own cells and of digested food.

405. Change of heat to energy. — The power which the body puts forth in performing work is derived from the heat of oxidation. The work of the heart requires the use of $\frac{1}{6}$ of all the heat produced in the body; the respiration requires $\frac{1}{60}$; digestion and absorption require a smaller amount. An ordinary day's work requires $\frac{3}{16}$ of the total amount of heat. So nearly three fourths of all the heat produced is used simply to heat the body.

406. Uniformity of temperature. — In some parts of the body oxidation is many times more active than in others. Probably most of the sugar is oxidized in the liver, and most of the fat in the lungs. As fast as heat is developed it is carried all over the body by the blood, so that there is scarcely half a degree's difference between the temperature in any two parts. Only the surface of the skin is cooler because it comes in contact with cooler air.

407. Fever. — When the temperature of the body is raised only a degree there is a feeling of warmth and discomfort, which is called a *fever*. The discomfort is worse as the temperature is higher. A temperature of 104 degrees is a sign of severe sickness.

408. Sensation of heat and cold. — If the temperature is lowered only a degree, there is a feeling of coldness called a *chill*. A chill is a recognized sign of beginning illness. The ordinary feeling of heat or cold is due to the state of the nerves of the skin, whose special duty is to conduct sensations of temperature. These nerves are so abundant in the skin that their sensations overpower the sensations of the rest of the nerves of the body. If the skin is warm, the whole body feels warm; while if the skin is cold, the whole body feels cold.

409. Chills during a fever. — It often happens during a fever that the blood goes to deeper parts, leaving the skin pale and without its usual supply of heat, and so the whole body feels cold, and the person has a chill, although the temperature of the body may be raised several degrees.

In severe sickness the heart is sometimes too weak to pump the blood to the skin, and so it feels cold, although the temperature of the inside of the body may be raised several degrees. This condition is often called *inward* fever. On the other hand, the body may be cold, and yet if the blood is brought to the surface, the person will feel warm.

410. Regulation of the heat produced. — The amount of heat produced in the same body varies widely at different times, and some persons always produce many times as much as do others. So in order to keep the temperature constant, heat must be given off at one time and saved at another. Nature regulates the temperature of the body by varying both the amount produced and the amount given off. The production of heat depends partly upon the amount of food. In summer man naturally eats less than in winter. Inhabitants of arctic regions eat large quantities of fat, the oxidation of which produces a large amount of heat, while the inhabitants of hot climates naturally avoid fat.

The production of heat also depends upon the amount of oxygen taken into the body. In work, deeper inspirations are taken, and more oxygen reaches the cells, and thus exercise warms the body.

411. Regulation of the heat given off.—Nature also regulates the amount of heat given off. The body loses some heat through the breath, and more by contact with the cool air. When the temperature of the inside of the body is raised, the blood tubes of the skin dilate, so that more blood comes in contact with the air. If the temperature falls slightly below the natural point, the blood tubes of the skin contract, so that less blood comes to the surface, and more heat is retained until the temperature rises to the natural point again. A change of temperature too small to be felt will produce these changes in the blood tubes of the skin.

412. Effects of tight bands.—When the circulation is hindered so that less blood enters any part of the body, its temperature falls. A finger whose veins are compressed by a tight string becomes perceptibly cooler in less than a minute. Garters often cause cold feet in the same way. Compression of the waist may cause the whole body to feel cold.

413. Effects of perspiration.—Sometimes men work in air which is hotter than their bodies. Then instead of giving, they receive heat. In order to keep them cool under these circumstances, nature has provided a self-acting bath by means of the *sweat*, or *perspiration*. When the temperature of the body is raised from any cause, the perspiration is poured out in greater quantity, which increases as the quantity of heat increases.

The heat of the body is used in changing the water of the perspiration to steam, which then passes off from the body. The process is

like the boiling of water in a teakettle, where the heat passes off in the steam, so that the temperature of the water does not rise beyond the boiling point. Some perspiration is given off even if the body is cold, but with an overproduction of heat more perspiration is often produced than can be turned into vapor. A person is usually said to perspire only when it is produced in so great a quantity that it collects in drops upon the skin.

414. Moisture in the air. — When there is a great amount of moisture in the air on a hot summer's day, the perspiration does not evaporate from the skin, and so heat is retained within the body, and the air seems "heavy" and oppressive. On such days the *humidity* of the air is said to be great. Dry air at a temperature of 90 or 95 degrees seems cooler than moist, humid air at a temperature of 80.

415. Sunstroke. — Men and animals, while working, produce a large amount of heat. On excessively hot and humid days the extra heat may not pass off so fast as it is formed, but may accumulate until the temperature rises several degrees. The increased heat overwhelms the body, and produces a sudden attack of faintness called *sunstroke*. The unconsciousness lasts for a long time, and is followed by great weakness, and sometimes by death. When a person is sunstruck he should be laid in a cool place, with his head lowest. Cold water should be dashed upon his head and chest. His limbs should be rubbed to help the circulation.

416. Damp days in winter. — While moisture in the air makes the body warmer in summer, in the winter it makes the air seem colder. Dry air is a poor conductor of heat, but a little moisture makes it a much better conductor. So a damp wind rapidly extracts the heat from the body, and seems to penetrate even thick clothing. Moist air at a temperature of 20 degrees seems colder than dry air at zero.

417. Heating living rooms. — In addition to the means provided by nature, man is often compelled to add devices of his own for regulating the heat of his body. Man lives

with the greatest comfort while the temperature of the air is about 70 degrees, which is but little more than half-way between the temperature of freezing and the heat of the blood. A temperature of 80 degrees feels too warm, while 90 degrees is hot, and $98\frac{1}{2}$, or the temperature of the body, is oppressive.

In winter a temperature of 70 degrees in a living room feels neither warm nor cold, and the change between it and the outside cold air is less noticeable than at any other temperature. A temperature of 75 or 80 degrees feels too warm, and when the person goes out of doors the cold air produces a sudden contraction of the arteries and a chill, which often results in taking cold. A sleeping room should be at a lower temperature than a living room.

418. Clothing. — Man protects his body against the loss of heat by covering it with clothes. Some kinds of substances readily permit heat to pass through them, and are called *good heat conductors*, while others carry heat poorly and are called *poor conductors*. *Linen* is a good conductor of heat. It is a poor protection against cold, for it lets out the heat of the body, but it makes good summer clothing. When the linen clothing is adjusted to one temperature, a change to cooler air is quickly and suddenly felt. Thus it is an undesirable clothing material in changeable climates or in cold weather.

Cotton also conducts heat readily, but if it is loosely woven, the air in its meshes makes it a poor conductor of heat. Then it makes warm clothing.

Wool is a poor conductor of heat. When the temperature is suddenly lowered, it permits the heat of the body to pass off but slowly, and thus gives the skin time to adjust itself to the change. In summer it retains too much heat, and does not make so good summer clothing as cot-

ton or linen, but when the temperature of the air is higher than that of the body, it prevents the heat from entering, and thus is cooler than linen or cotton. So men who tend hot furnaces are cooler if they wear thick flannel than if they wear linen or cotton.

Silk is also a poor conductor of heat. While more expensive than wool, it is lighter in weight and feels softer to the skin, and so makes the best kind of clothing.

Fur is the poorest conductor of all, and is the best protector against cold. Nature has given a thick coat of fur to animals that live in cold regions. In winter their fur is long and thick, but it drops out during spring, and a new fur grows during the summer, becoming thick and long again by the following winter.

Air itself is a poor conductor of heat, and when a considerable quantity is imprisoned in the meshes of cloth, the garment offers a greater resistance to the passage of heat. So loosely woven cloth is much warmer than cloth made up of tightly twisted thread. Fur is warm largely because of the amount of air which it imprisons. For the same reason loose clothing is warmer than tight-fitting clothes.

419. Color and heat. — When exposed to the sun, black objects take up twice as much heat as white objects. This difference of temperature is noticeable in clothing. Light-colored or white clothing is best for summer, and dark-colored or black for winter.

420. Distribution of clothing. — The different parts of the body vary in their ability to resist cold. The face and hands usually need no covering. The feet need less than the body, while the back, chest, and abdomen need the most. Nature has distributed fur upon the animal's body in the same way, leaving the head and feet poorly covered. The sense of warmth is the best guide as to the amount of clothing to be worn on any part. A person should wear enough to keep each part of the body comfortably warm, while no part, especially one which is usually left uncovered, should be covered so as to be uncomfortably warm.

Dampness produces cold by the evaporation of water. If all the

clothing is wet, heat is taken from the whole body equally, and there is equal contraction of the arteries with no congestion or inflammation. But if a single part is wet, it feels cold, while the rest of the body is warm; so wet feet often produce inflammation of different parts of the body.

Cold feet. — When the feet perspire a great deal, the stockings and soles of the shoes become saturated with moisture and make the feet feel as cold as if they were wet. Thicker stockings make the feet perspire still more, and so do not add to their warmth. Tight shoes allow of no ventilation, and so the moisture is retained, and the feet are wet and cold.

Drying the shoes and stockings every night before the fire will prevent their becoming saturated with moisture. A new inside sole cut out of thick paper put in the shoe each morning will absorb moisture and help keep the feet warm. Rubber boots and shoes do not permit the moisture of insensible perspiration to pass off, and so they seemingly cause the feet to perspire.

Bathing the feet each morning in cold water and drying them by brisk rubbing improves the circulation, so that they will be more likely to stay warm all day.

421. Paper as a protection against cold. — Paper is a poor conductor of heat. A newspaper wrapped around the body under the coat is as good as an overcoat for warmth. A few newspapers spread between the quilts of a bed will make up for a lack of bed clothing upon a cold night. One need not suffer from insufficient clothing, day or night, if a few newspapers are at hand.

422. Sufficient clothing. — The amount of clothing which one needs depends largely upon a person's occupation and previous habits. A day laborer seldom needs an overcoat, but works in his shirt sleeves, while a clerk would be chilled were he to step outdoors without extra wraps. It is a mistake to think that by exposure to the cold one can always become hardened to it. It is true only when a person takes active exercise and lives out of doors continuously. The body cannot adapt itself to the sudden changes from hours spent in a warm room to an hour or two in the cold air. Enough clothing should be worn so that the body

does not feel chilled on entering the cold air. When by exercise the body feels warm, the overcoat may be unbuttoned or removed, but while one is resting it should be put on at once before the body feels chilly. Cold air blowing on our body while it is heated may cause us to have pains in our muscles and joints.

423. Airing clothes at night. — At night it is usually best to remove all clothing worn during the day. Woolens have the power of absorbing a great deal of moisture without feeling damp. But the moisture and the waste matters from the skin should be removed each night by thoroughly airing the underclothes. If it is not done, the woolen may become so saturated with moisture that it affords no more protection than cotton, and so may render a person liable to take cold.

424. Beds. — Feather beds and thick quilts enable a person to get warm when he goes to bed on a cold night, but after he falls asleep he becomes too warm and perspires too freely. Then he throws off the coverings, and soon the evaporation of the perspiration makes him cold. We should use as thin bed covers as possible so as to avoid overheating. If we sleep in a very cold room, we can keep ourselves comfortably warm with light covers if we use woolen blankets for sheets instead of sheets made of linen or cotton. As a rule a plain mattress is more comfortable and gives a more even heat than a feather bed; but in beds, as in clothing, a person's sensation forms the best guide as to the kind to be used.

425. Effect of lowering the temperature of the body. — In extremely cold weather heat may be lost from the body faster than it can be produced, and thus the temperature falls. Then the body and mind cannot act, but become numb and sluggish, just as the hands become numb and powerless when cold. If the temperature continues to fall, the respiration becomes less, and as the cells cease to act

an agreeable feeling of drowsiness steals over the mind, until the actions of life cease. After the drowsy feelings begin, life can be restored only by applying heat to the body and performing artificial respiration so as to start the process of oxidation again.

426. Frost bites. When a part becomes very cold the cells may be seriously injured long before they are frozen. A toe or an ear which has been on the verge of freezing will begin to prick and tingle when warmed. For a long time afterward, sensations varying from an itching to severe pricking and smarting will cause great annoyance. In severe forms, short of actual freezing, the part swells and becomes red and inflamed, while the sensations are extremely annoying. A part which is actually frozen is likely to die. The part turns black soon after being thawed, and has no feeling. After a few days the dead part comes off, leaving a raw sore. Fingers, toes, and ears are very liable to become frozen, but the eyelids are almost the last thing to freeze.

427. Frozen limbs. — When a solution of a substance in water freezes, the first ice formed is composed of crystals of pure water, while that frozen last contains most of the dissolved substance imprisoned in the meshes of the crystals. The cells of the body are made of water in which albumin and mineral substances are dissolved. When freezing occurs, the first ice is composed of needles of pure water which has been taken from the cells. If the freezing takes place rapidly, the water produces swift currents which break down the delicate framework of the cells and cause their death. If freezing occurs very slowly, the water may leave the cells so slowly that no damage is done by the tiny flood. If thawing occurs just as slowly, the water may reënter the cells so that they may be preserved alive. When a hand or a foot is frozen, it should be rubbed gently either with snow or else while immersed in ice water, and the raising of the temperature of the water should be done very slowly, taking, at least, two or three hours for the thawing process. The preservation of the frozen part depends upon

its very slow thawing. Never apply warmth of any kind to a frozen part, and avoid sitting near a warm stove afterwards.

428. Effects of raising the temperature of the body. — When a living body is exposed to a higher temperature than is natural, the respiration and circulation are much increased by the extra heat and there is much mental excitement. In fevers there are usually excitement and delirium. A continuous temperature of 105 degrees is usually fatal.

It is possible to work in an atmosphere which has a temperature of 150 degrees or more, and men have remained in hot ovens for many minutes without harm. Their perspiration flows very freely, and its evaporation carries off the extra heat, so that the temperature of the body does not rise. If the perspiration should cease, the temperature of the body would rise at once, and death would soon take place.

429. Burns. — A temperature of 110 degrees feels very warm, 115 degrees is hot, while 120 degrees is all that a person can commonly stand. A temperature higher than this injures the cells so that a blister will be raised in a few minutes. A temperature of 170 degrees coagulates albumin at once and so destroys the life of cells which it touches. A temperature of 212 degrees, or boiling point, at once produces a deep scald, while higher temperatures burn the skin to a crisp.

Cold water applied at once to a burn prevents its extension and soothes the smarting, but it should be applied only for a short time lest it should injure the cells. Common baking soda is one of the most soothing applications. A mixture of linseed oil and lime water is a good application for continuous use. After a deep burn has healed, a puckered scar will be left, but the scar will be less noticeable if healing is hastened by skin grafting.

430. Burning clothing. — When the clothing on a person takes fire, a great danger is that the flames may be inhaled. It will take some time for the flames to penetrate to the flesh, but they may quickly spread upward. So a person should always *lie down at once*. Then let him roll over and over so as to crush out the fire. Even if the fire is not extinguished, the flames cannot reach the face, while the clothes can be removed as well lying down as while standing. In helping a

person whose clothes are burning, at once *throw the person to the floor*. Many have lost their lives by persisting in standing up while attempting to remove the burning clothes.

If it is necessary to enter a burning building, or to carry a person whose clothes are burning, the best protection will be to wrap a thick coat or blanket around the body. A thick coat wrapped around burning clothes or thrown over the body after a person lies down will quickly smother the flames.

431. Alcohol and heat. — The amount of heat in the body depends upon the balance between its production and its loss. The rapid destruction of alcohol, in all probability, yields heat too rapidly to be utilized by the body. The most constant effect of taking alcohol is to dilate the arteries of the skin, so that an extra amount of heat is lost. More heat is always lost than is produced. Alcohol lessens the power of the body to endure cold. On a cold day when the arteries of the skin are contracted so that there is but little blood to warm its nerves, alcohol may send the blood to these nerves and produce an agreeable sense of warmth, but in reality this feeling of warmth is due only to the heat which is passing off from the interior of the body.

432. Regulation of temperature in the dog. — The temperature of many animals is slightly above man's temperature, but is regulated in the same way. Some, like dogs, sweat but little, but the animal takes short and rapid breaths through his open mouth, thus creating a strong current of air over its moist surface. The evaporation of the saliva cools the blood.

433. Hibernation of animals. — When winter comes on, some animals, like the woodchuck, retire into their holes and go to sleep. Their temperature falls to 50 degrees, or even lower, while respiration occurs only three or four times a minute. Only enough oxidation of their own bodies occurs to keep life from completely dying out.

When warm weather comes again, their respiration and temperature rise to the natural point, and the animal resumes its former condition, but is thin from the oxidation of its fat and albumin during his long sleep. The dormant state during the winter is called *hibernation*.

434. Cold-blooded animals.—In frogs and snakes, oxidation is not sufficient to raise their temperatures much above that of the surrounding air. So they feel cold to the touch, and are called *cold-blooded*. On warm days they do not lose heat so rapidly, and more heat is retained within their bodies, and thus they become more active. When cold weather comes on, they cannot produce enough heat to enable them to move, but they lie unconscious until warm weather comes again.

Insects cannot produce enough heat during winter to enable them to fly about, so they remain apparently lifeless until the warm weather comes again.

SUMMARY

1. The heat developed by oxidation is distributed through the body by the blood so that everywhere it has a temperature of 98.5 degrees.
2. The sensations of heat and cold are caused by the blood circulating in the skin. If little circulates, we feel cold; while if much circulates, we feel warm.
3. An increased quantity of food, oxygen, or exercise increases the amount of heat produced in the body.
4. Heat is given off by contact of the skin with the cold air and by means of the perspiration.
5. A temperature of about 70 degrees in a room is the most comfortable.

6. Moisture in the air prevents the evaporation of perspiration, and increases the feeling of warmth.
7. Fur, silk, woolen, cotton, and linen protect the body from cold in the order given.
8. Raising the temperature of the body causes excitement and delirium.
9. Alcohol dilates the arteries of the skin and permits an increased loss of heat, in spite of the feeling of warmth.
10. In animals while hibernating, and in all cold-blooded animals, oxidation is feeble, the temperature is low, and their movements are sluggish.

DEMONSTRATIONS

97. To show that more blood goes to a part, and that it becomes warmer while acting, let a boy roll up his sleeve and hang his arm by his side. Notice that the veins slowly fill, because the flow of blood is slowed by running up hill. Now have him open and shut his hand rapidly, and notice that at once the veins become filled full of blood. After a moment the hand feels warmer than the other, especially if they were a little cold at first.

98. Take some ice water, some water at the temperature of the air, and some hot water. Notice that the water at the medium temperature feels warm when the hands have just been taken from the ice water, but cold when they have just been in the hot water.

99. Feel of a piece of iron and of a stone after exposing both to the cool outside air. Notice that the iron feels colder, for it takes heat from the hand faster.

100. To show that obstructing the flow of blood makes a part cold, tie a string rather tightly around the finger. In a moment it becomes filled with venous blood, and feels cold, for the blood is not renewed.

101. That the sensation of heat and cold depends partly upon the amount of blood in the skin can be shown by holding a piece of ice in the hands for several minutes. At first, the hands feel cold, for the arteries are contracted. In a little while the blood circulates freely

again, and there is a feeling of warmth, although the ice still continues to cool the hand.

102. Take some cotton and some woolen cloth of equal thickness. Wet them and notice how much more quickly the cotton will dry than the wool. Wrap them around the hand and notice that the woolen feels warmer, because evaporation from it does not carry heat away from it so fast as from the cotton. Then blow upon them and notice how much colder the cotton feels.

103. Place two pieces of ice of equal size in the sun and cover one with a black cloth and the other with a white piece of the same kind, and notice that the piece under the black cloth melts faster.

104. Needles of water crystals can be shown by setting aside a cup of water out of doors until it just begins to freeze, if it is a cold day, or, if it is a warm day, by putting a large piece of ice in the sun and breaking it when it is half melted. Each needle is pure water.

105. A wasp or a fly will illustrate the hibernation of animals. In winter a few wasps can usually be found in a sunny garret window. When the air is quite warm, the wasps will be lively, and as it becomes colder they become more sluggish, until at night they are apparently lifeless.

REVIEW TOPICS

1. Give the temperature of the body and tell how the heat is distributed.
2. State what causes sensations of heat and cold, and how the body may feel warm while it is cold, and cold while it is warm.
3. State how the production of heat is regulated.
4. State how the amount of blood in the skin regulates the amount of heat given off.
5. State how the perspiration regulates the amount of heat given off.
6. State how tight bands about a limb cause cold feet or hands.
7. Give the best temperature of living rooms and of bed rooms.

8. Give the effect which moisture in the air has upon the heat of the body during summer and during winter.
9. Give the value of linen as a protection against heat and cold; of cotton; of wool; of fur; and of air.
10. State how color affects temperature.
11. State how much clothing should be worn, and how it should be distributed over the body.
12. Discuss feather beds and thick bed coverings.
13. Give the effects of lowering the temperature of the whole body; of frost bites; of frozen limbs; and their treatment.
14. Give the effects of raising the temperature of the body, as in fever and in sunstroke.
15. Give the effects of alcohol upon the temperature of the body.
16. State how a dog's temperature is regulated.
17. Describe the hibernation of animals.
18. Describe oxidation in cold-blooded animals, and in insects.

CHAPTER XXVI

EXCRETION AND SEWAGE

435. Getting rid of oxidized and waste substances is *excretion*. All oxidations in the body produce carbonic acid gas and water. In addition, the oxidation of albumin produces a substance called *urea*, which contains the nitrogen of the albumin. These substances together with the minerals or ashes left from the burned cells must continuously be excreted by the lungs, liver, intestine, skin, and kidneys. These organs also excrete poisons which are produced by disease germs.

436. Difference between a secretion and an excretion. — In a general way, anything separated from the blood by glands is a *secretion*. But the term strictly is applied only to those substances which, like saliva and gastric juice, are of use to the body. Substances which, like carbonic acid gas and urea, are only waste and harmful products, are true *excretions*.

437. Sweat glands. — Numerous coiled tubes lined with epithelium project into the skin over nearly its whole surface. Each tube is a *sweat gland*, whose epithelium is continually secreting the *sweat*, or *perspiration*. They are very numerous on the forehead, chest, palms of the hands, and soles of the feet. Only a few are found in the upper part of the back.

438. The perspiration. — The perspiration is over 99 per cent water. It contains a small amount of urea and mineral substances. Ordinarily it evaporates so fast that its

presence is not noticed. Nearly a quart of water a day thus passes off from the surface of the body in insensible perspiration. In hot weather and during exercise so much is produced that it accumulates in drops upon the skin.

439. The kidneys. — The main work of excretion is performed by the kidneys. There are two kidneys, one on each side of the backbone, half covered by the two lower ribs. Each kidney is bean-shaped, about four inches in length, by two in breadth, and one in thickness. It is composed of millions of fine tubes made up of epithelial cells; they unite, and finally open into a pocket on the side of the kidney.

440. How the kidneys excrete. — The epithelial cells of the tubes have the power to draw urea and mineral substances from the blood. They also extract a large amount of water in order to wash away the excreted matter. The excretion runs down a tube called the *ureter* to the bladder. About a quart and a half of a fluid called *urine* is thus excreted daily.

441. Kidney disease. — Kidney disease usually takes the form of an aggravated bilious attack. There are headaches, loss of appetite, coated tongue, and great weakness. Usually the urine is diminished, and contains some albumin derived from the blood.

Urea itself is as harmless as carbonic acid gas and is as easily excreted, but when oxidation is incomplete, substances are produced which are as much more harmful than urea as a smoking lamp is more unpleasant than one burning perfectly. When more food is eaten than can be oxidized, poisons are developed from the imperfectly oxidized albumin. Some are leucomaines or substances like them. The kid-

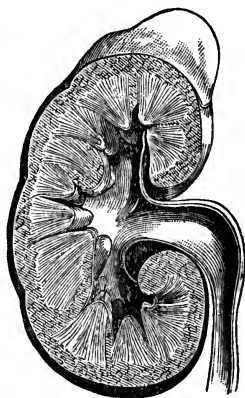

Kidney cut across.

neys try to excrete the poisons, but they become overworked, producing what is called *Bright's disease*. Then the sweat glands excrete more waste matters, and in the emergency often do enough to relieve the kidneys.

442. Relation of the skin and kidneys. — The skin excretes but little urea compared with the kidneys, yet its capacity for excreting water is unlimited. When much water is excreted by the sweat glands, only a little is excreted by the kidneys, and when little perspiration is formed, the kidneys excrete more water. The amount of urea remains nearly the same from day to day, and so the urine will be more colored at one time than another.

The amount of perspiration is governed principally by the temperature, and remains nearly the same whether much or little water is taken. The amount of urine is increased by the water swallowed. A large amount of water tends to wash away the urea more perfectly. Often when one thinks that he has kidney trouble, an increased amount of water swallowed will pass through the kidneys and bring their secretion to a natural appearance.

443. Excretion of poisons swallowed. — When poisons have been swallowed, those which pass by the liver are seized by the kidneys and excreted. Carbolic acid and turpentine are thus excreted by the kidney. In passing through the kidneys these drugs may irritate their cells and set up inflammation. Most drugs, whether they are vegetable or mineral, pass out by the kidneys.

444. Excretion by the liver. — The liver is constantly destroying all kinds of poisons, which it receives not only from the blood of the intestine, but also from the rest of the body. Two bile substances, *glycocholic* and *taurocholic* acids, are probably formed directly from albumin; and while they are excretory products, yet they are elements essential to digestion. Another substance, *bilirubin*, contains most of the waste coloring matter of the blood. When the liver fails to excrete these substances, as in *jaundice*, they pass out by the kidneys and color their secretion yellow.

445. Excretion by the intestine. — Although the intestine absorbs food, yet it also pours out some waste matters.

When the intestine does not expel its contents, symptoms like liver and kidney diseases arise. So the intestine excretes some waste matter. Under certain conditions even the stomach may become an excretory organ, and vomiting may be a life-saving act, just as it often is when poisons are swallowed.

446. Intemperance and kidney disease. — *Alcohol*, by disturbing oxidation and the liver, is especially liable to cause the production of poisons whose excretion severely taxes the kidneys. It alone causes over one half of kidney diseases. Candies, pie, cake, and preserves are all eaten simply for their taste, and usually after a sufficient amount of proper food has been taken. So, in oxidizing this increased amount of food, some must be imperfectly oxidized. Thus poisons are developed and the kidneys are overworked.

Intemperance in sugar eating is extremely common. It produces imperfect oxidation in the same way as alcohol, only its effects are much slower and less noticeable.

447. Sewage. — The excretions of man and animals, together with the dirty water used in washing, is *sewage*. Sewage is composed of substances which are often very poisonous, and often contain disease germs (p. 136).

448. Purification of sewage. — Nature is very efficient in changing sewage so that it is no longer harmful. In the upper layers of the soil it is fully oxidized to carbonic acid gas and water and mineral substances. The soil can dispose of a great quantity of sewage and prevent it from polluting the surrounding wells.

In the second place, plants feed upon sewage. They aid in its oxidation and use it as food. Thus plants may form again the substances which were oxidized in man's body so that he may eat the very products which he once excreted.

In the third place, running water washes away sewage, and by means of the oxygen which it always contains it fully oxidizes the excretions.

449. Danger from sewage. — Sewage often is a poison itself, and when much is collected it often develops poisons by its decay. The foul smell of sewage is due to gas

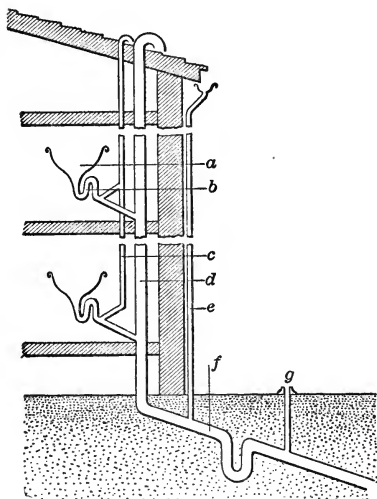

Diagram of the plumbing of a house.

- a* sink or washstand.
- b* trap, which remains full of water and prevents the entrance of sewer gas.
- c* air pipe for ventilation and to prevent the water from being sucked out of the trap.
- d* waste pipe, down which the slops pass into the sewer.
- e* pipe from the gutter on the roof.
- f* waste pipe passing under the street.
- g* ventilation pipe.

called *sewer gas*. While the gas itself is but slightly harmful, yet it is a sign of decay and of lurking sources of danger. But sewage is dangerous mainly because it may contain germs of typhoid fever and other diseases which come from the excretions of sick persons.

450. Disposal of sewage.

— In thinly settled country places small quantities of slops and sewage may safely be emptied in the back yard, for the soil destroys and removes all offensive matters and disease germs, so that only pure water reaches the deeper layers of the ground. If a house has a bath room, there will be so much waste water that some device will

be needed for its disposal. The simplest contrivance is to conduct the sewage into a hole called a *cesspool*, from which it slowly soaks into the ground. A cesspool should always be so located that the underground flow of water from it will be away from any wells (p. 136).

451. Sewers. — In cities the houses are too near together to permit the use of cesspools, and so underground tubes or tunnels, called *sewers*, are built at public expense in order to conduct the sewage outside the town. There it should be treated in a sewage disposal plant, although it is often emptied into the nearest body of water (p. 407).

452. Plumbing. — In houses pipes are arranged to carry off the sewage as fast as it is formed in the sinks, wash bowls, and closets. Since they open into a common sewer of the town, sewer gas can readily enter the houses. To keep it out, each pipe is bent into a loop which remains full of liquid and prevents the entrance of gas.

453. Cleanliness. — No matter how good the natural or artificial drainage may be, if decaying matter is left in cellars, it may poison the air. Sinks may become clogged and poison the air, while slops and dirty dishes may be carriers of disease. So cleanliness is of great importance, aside from its mere looks.

454. Choice of a house site. — In choosing a site for a dwelling house we should consider the natural drainage of the ground. If the soil is low and marshy, or if the subsoil consists of clay or rock, the sewage may not soak away readily. Mosquitoes breeding in marshy ground may cause malaria (p. 225). The site for a house should be such that the barnyard and outhouses can be put so they will drain away from the house and well. Attention to these details of drainage is of far more importance than the natural beauty of a site.

SUMMARY

1. Excretions are waste and poisonous substances expelled from the body. The principal ones are carbonic acid gas, water, urea, and mineral matters.
2. Sweat, or perspiration, is formed in tubes in the skin. It contains some urea and mineral matters.
3. The kidneys are collections of minute tubes which separate urea, mineral matter, and water from the blood.

4. When, in Bright's disease, or from any other cause, the kidneys cease acting, death by poisoning soon takes place.
5. The skin can aid the kidneys, but cannot take their place.
6. Alcohol causes poisons to develop whose excretion overworks the kidneys.
7. The liver and intestine each excrete a great amount of waste and poisonous substances.
8. The excretions from man remain poisonous until destroyed by the soil, by plants, or by running water.
9. In thickly settled districts it is necessary to carry off the excretions by means of a sewer.

DEMONSTRATIONS

106. Carefully weigh several boys early on a warm day. Have them run about and take violent exercise, eating and drinking nothing, or only known amounts. In a few hours weigh them again. A loss of half a pound or more may be noted.

107. Insensible perspiration may be shown by touching a cold glass to the skin, when moisture will at once condense upon the glass.

108. Secure a specimen of kidney mounted for the microscope. With a power of about 200 diameters show the class how capillaries form a bunch in a pocket at the beginning of each tube, and then pass out to surround the tubes, and finally unite to form the veins. Show them the large size of the cells of the tube.

109. Cut open a pig's or sheep's kidney lengthwise and notice the pocket in its side and the radiating lines of the kidney reaching almost to the surface and marking the course of the tubes.

110. A pot of growing flowers will illustrate nature's method of disposing of sewage. Although manure and dirty water are poured upon the earth, yet they give out no odor, but become fresh and clean and nourish the plant.

111. Show the pupils the traps for sewer gas under the sinks.

REVIEW TOPICS

1. Explain the difference between a secretion and an excretion.
2. Name the principal excretions and tell how they leave the body.
3. Describe sweat glands and the perspiration as an excretion.
4. Describe the kidneys and their excretion.
5. Discuss how imperfect oxidation may overwork the kidneys.
6. Show how the skin aids the action of the kidneys and how the one acts less when the other is more active.
7. Show how alcohol produces kidney diseases and how sugar acts in the same way.
8. Describe three ways in which nature destroys the excretions of man.
9. Discuss the dangers which may arise from sewage.
10. Tell how sewage is disposed of in cities.
11. Describe how sewer gas is prevented from entering houses through waste pipes.

CHAPTER XXVII

THE SKIN AND BATHING

455. The derma. — The skin is the tough, loose sack which covers the entire body. It is designed to protect

the body and to give off perspiration and heat. (See pp. 235, 248.)

The main part of the skin is a tough, elastic network of fibers, called the *derma* or *cutis*, which forms a layer from $\frac{1}{16}$ to $\frac{1}{8}$ of an inch in thickness.

The derma of animals, when tanned, forms leather. The skin is connected with the body by a loose network of fibers called the *subcutaneous tissue*, which permits the skin to move freely over the deeper parts. Over some parts of the body, as upon the abdomen, the subcutaneous tissue contains a thick layer of fat.

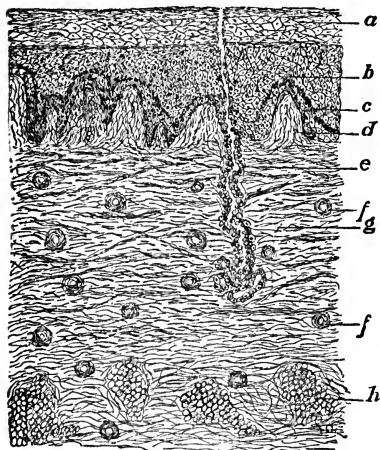

The skin ($\times 100$).

- a* dead layer of epidermis.
- b* growing layer of epidermis.
- c* layer of cells containing the coloring matter of the skin.
- d* papilla.
- e* sweat gland.
- f* small blood tube.
- g* fibers of the derma.
- h* fat cells in the derma.

456. The epidermis. — The derma is covered with a layer of epithelial cells, called the *epidermis* or *cuticle*. New cells are continually being produced in the deeper layers of the epidermis, while the older cells become matted in a firm mass which is continually being worn away. These cells are directly continuous with the epithelial cells of the mucous membrane and are of the same nature. The epidermis has no nerves and no blood tubes.

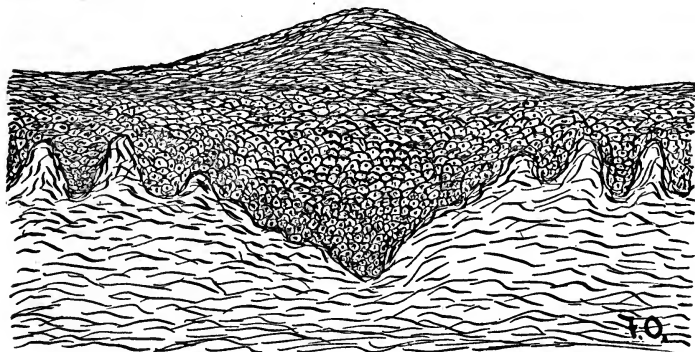

A corn.

457. Upon the palms of the hands and soles of the feet the epidermis forms a very thick layer for the better protection of these much-used parts. When hard labor is performed with the hands, nature causes the protecting epidermis in the exposed parts to form a thick and horny spot called a *callus*. Sometimes pressure and rubbing cause a small area to become thickened so that a point of hardened cells is formed which presses into the deeper parts of the skin. This is a *corn*.

When the skin is vigorously rubbed, or certain drugs are applied, the deeper layers of the epidermis are killed, and water accumulating between them and the outer layers raises a *blister*.

458. Color of the skin. — The deeper layers of the epidermis contain colored granules which give the peculiar color to different races of men. Exposure to the sun's rays produces a darker coloring matter. In some people the coloring matter is deposited in small spots called *freckles*.

459. Skin grafting. — A spot of skin deprived of epithelium is tender and sore. New flesh forms over its surface, while the epithelial cells at its edge produce new ones which spread over the whole surface and complete the healing. If they do not grow, the new flesh sprouts above the skin, forming *proud flesh*.

The deeper cells of the epidermis may remain alive for some hours after being cut off from the body. When placed upon a clean ulcer, they may grow and produce a new epithelium. This is *skin grafting*.

460. Papillæ. — From the surface of the derma small projections about $\frac{1}{200}$ of an inch in length, called *papillæ*, extend a short distance

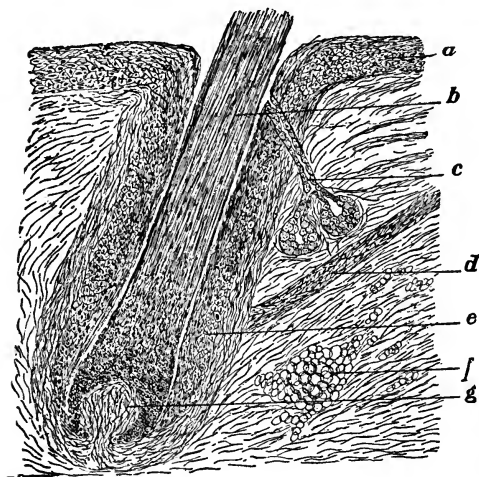

A hair ($\times 200$).

- a epidermis of the skin.
- b hair shaft.
- c sebaceous gland.
- d muscle which makes the hair erect.
- e epidermis of the hair root.
- f fat cells in the derma.
- g papilla from which the hair grows.

tance into the epidermis. They contain nerves of feeling. The papillæ over a small area sometimes become overgrown, so that they project above the skin, forming a *wart*. Rows of papillæ form the fine curved lines upon the balls of the fingers and the palms of the hands. They are most numerous where the sensation of touch is greatest.

461. Hair. — Extending obliquely nearly through the derma are numerous minute tubes lined with epithelium. Their cells become joined together in a tough string, called a *hair*, which projects out of the tube. When the hair is pulled out, the epithelium covering the projection in the tube soon produces another hair. A small muscle is attached to the bottom of each hair root. Cold causes the muscles to contract and to pull the hair tubes to an upright position imparting to the skin a roughness called *goose flesh*. Hair covers almost the entire body.

462. Sebaceous glands. — Near each hair is a gland called a *sebaceous gland*. It secretes a kind of oil, which softens the skin and keeps the hair glossy. The glands are especially numerous down the center of the face. When their mouths are stopped by dirt they often become distended and form small, black spots called *black-heads*, which are often mistaken for small worms.

463. Nails. — The epidermis upon the backs of the last joint of each finger and toe is hardened into a *nail*. The nail is formed at its back part and is pushed onward in its growth. An epithelial cell remains a part of the nail about three months before it is pushed from its root to its end.

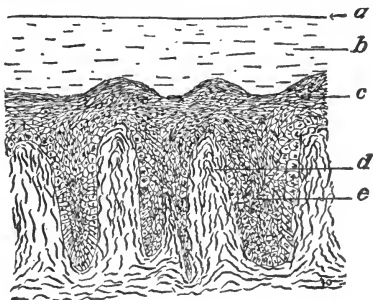

A nail ($\times 200$).

- a surface of the nail.
- b body of the nail.
- c epithelial cells just before they are welded into a nail.
- d papillæ.
- e growing epithelium.

464. The complexion. — In health the skin has a velvety appearance, and a rosy color, and is free from spots or scales. Its moisture is

of the proper degree to cause it to feel soft and pliable. Its appearance is changed by ill health. If the stomach and intestine are not in good order, it is almost impossible for the skin to be beautiful. Plain food, fresh air, and exercise make a beautiful skin, and no skin can be beautiful without them. Cold dry air or exposure to the sun's rays often cause it to become red or to blister. These effects are much greater upon those who are unaccustomed to the exposure.

465. Care of the complexion. — Washing the skin with soft water and soap as often as it becomes dirty, and following it by a thorough drying with a soft towel, are the only effective means of beautifying the skin. Paint, powder, and perfumery cannot cause the skin to grow more beautiful. They simply coat its outside, and at the same time stop its sebaceous and sweat glands, so that when it is removed the skin looks worse than before. They act like any other dirt. Many of these preparations contain poisonous minerals such as lead.

Drugs taken internally to beautify the skin act mainly through the arsenic which they contain. Arsenic destroys the blood cells, and so gives a peculiar paleness to the skin. Paleness is only a sign of poisoning which is working harm to the health.

466. Absorbent power of the skin. — Since the outer part of the epidermis is dry and dead and contains no blood tubes or lymphatics, substances rubbed upon the skin will not be absorbed. So man can handle virulent poisons and disease germs without danger. On the other hand, when the epithelium is removed, the exposed blood tubes and lymphatics take up drugs and poisons very readily. Drugs may be absorbed from surgical dressings, and germs of disease may enter through even a minute scratch.

467. Care of the hair. — The hair of man, like that of animals, is soft and glossy in health, but often dry and rough during disease. Daily brushing to remove the dirt, and to distribute the oily secretion of the sebaceous glands, will keep the hair in the best condition. All that is necessary beyond this is frequent washing with soft water. The secretion of the sebaceous glands is sufficient to oil the hair and scalp. There is no substance which will cause hair to grow, neither will any

stop its growth. When hair is shaved off, it soon regains its former length and then ceases to grow. Shaving seems to have some effect in causing the hair to grow coarser, but it does not add to the number of separate hairs.

468. The beard. — At about the age of sixteen the hair upon a boy's face begins to grow larger and coarser, and if let alone becomes a full beard in the course of two or three years. A shaved beard is not so silky as one that has never been cut.

A beard gives to a young man an appearance of age and experience and is popularly taken for a sign of mental and physical strength. As a matter of fact the presence or absence of a beard has nothing to do with a person's experience or knowledge.

469. Care of the nails. — Biting the nails makes their edges ragged, besides making the ends of the fingers sore. The nails themselves are not poisonous, but underneath their projecting ends germs of disease may be mixed with the dirt which gathers there. Naturally the nail adheres to the finger nearly down to its end, but is often kept raised and sore by too persistent cleaning. The edge of the semicircle of flesh surrounding the root of the nail is naturally soft and slightly raised so that it looks like a fine silken braid. Sometimes it becomes hard and cracks, especially upon cold, dry days. Cutting away the hard edge down to its soft margin in the flesh prevents the extension of the cracks. A tiny sliver of the edge of flesh around the nail torn back into the flesh forms a *hangnail*. The hangnail should be cut off close to the flesh. It is best prevented by gently pushing the skin back from the nail. Tight shoes bind the toes together, curving the great toe nail into the flesh, causing an *ingrowing* toe nail. Broad shoes are the best preventive of the trouble.

470. Bathing. — A noticeable odor of perspiration about any part of the body is a sign of uncleanness, and is the best indication of the need of a bath. Even in cold weather a bath is needed at least once a week, while in the summer it may be necessary to bathe daily. Soap and hot water soften the epithelium, and if the skin is then rubbed vigorously, a large amount may be rolled into small balls, which are often supposed to be dirt. When much epithelium is removed in this way, the body is more sensitive to the cold,

the perspiration passes off with greater ease, and the skin is made tender.

471. Hot baths. — The heat of a bath in which the body is kept warm from the time it enters the water until it is dry dilates the blood tubes of the skin, so that the blood accumulates upon the surface. Thus the internal organs contain less than their natural supply of blood, and the body is apt to feel weak and drowsy. After mental labor a hot bath may cause the blood to leave the brain and so bring about sleep. When a cold is coming on, a hot bath may increase the excretion of poisons from the skin. Then the body may be able to overcome the germs of the sickness, and thus the cold may be prevented. The proper time for a hot bath is at night, just before retiring, so that the circulation may become natural before morning. A hot bath requires the use of a warm room, and of a tub sufficiently large to admit most of the body at once, for evaporation of the warm water causes a cold feeling on coming out of the bath.

472. Cold baths. — When a cold bath is taken, the blood tubes of the skin at first contract and give a cold feeling; but they soon dilate. With the dilatation there comes an increased flow of blood throughout the whole body, so that there is a feeling of warmth and vigor in marked contrast with the drowsiness of the hot bath. The invigorating effects of a bath are called its *reaction*. If a cold bath is long continued, there comes on a second contraction of the arteries, so that the blood is forced within the body, producing a feeling of coldness and weakness from which the body is a long time in recovering. This second contraction of the blood vessels is called the *secondary reaction*. The bath should be stopped at the first appearance of a chill.

473. An easy way of bathing. — A cold bath requires nothing more than some water and a towel. A simple wetting of the body with the hands, followed by rubbing with a soft towel, produces all the effects of an elaborate bath tub. Such a bath can be taken in two minutes upon rising and is very invigorating and refreshing.

474. Turkish baths. — A Turkish bath is a combination of hot and cold baths in which the body at first is made to perspire in a hot bath while being rubbed. The body is then suddenly deluged with cold water and rubbed dry. At night the bath is refreshing, but the removal of epithelium and the excessive perspiration make the bather liable to take cold.

475. Sea bathing. — Running water carries off the heat of the body, and thus produces a greater effect than still water. The motion of the waves makes sea bathing exhilarating, and the salt in the water seems to have some stimulating effect.

476. Bathing in fevers. — A cold bath always lowers the temperature of a feverish person, and if properly given, greatly adds to his comfort. It also stimulates the skin to greater activity so that it aids the kidneys in their work of excretion. A good way of bathing a feverish person is to uncover only an arm, and wet it with lukewarm water. Then gently rub it with the bare hands until it is dry. The evaporation rapidly produces an agreeable coldness, while the rubbing keeps up the circulation and prevents taking cold. Then cover it and go over the other arm, and then the legs, and the body in the same way. Finish by washing the face and brushing the teeth. It is proper to give such baths several times a day if the fever is high.

SUMMARY

1. The skin consists of a thick network of connective tissue, called the *derma*, covered with several layers of epithelium, called the *epidermis*.
2. A hair is formed by the welding together of epithelium in a minute tube in the skin.
3. Sebaceous glands pour an oily substance upon the hair roots to soften the skin and hair.

4. At the backs of the ends of the fingers and toes the epithelium is thickened and hardened to form the nails.
5. Digestive disturbances are the principal causes of a poor complexion.
6. Paints and powders irritate the skin and have the same effect as dirt.
7. Daily brushing the hair and frequently washing it with soap and water are the best means of keeping it soft and glossy.
8. Nails should be smoothly trimmed, and gently cleaned.
9. The skin should be washed often enough to prevent an odor of perspiration.
10. The heat of hot baths dilates the arteries of the skin so that blood leaves the internal organs and brain and produces a feeling of rest and drowsiness.
11. A cold bath contracts the arteries of the skin. But they soon dilate and produce a feeling of warmth and exhilaration, called the *reaction*.
12. If a cold bath is continued, the arteries again contract, producing chilliness and a feeling of exhaustion.

DEMONSTRATIONS

112. Examine a specimen of skin with a microscope. Notice the network of connective tissue in the derma, and the numerous arteries and veins. Notice its projections of papillæ and their covering of epithelium. Notice that the epithelial cells in the deepest layers are large and round, and the outermost layers are flat and shriveled and can scarcely be recognized. Notice a faint line of colored granules in the third or fourth layer of cells. In a negro the colored layer is very distinct. The specimen will also probably show one or two winding sweat glands.

113. The skin specimen will probably show a few hairs, but one specially prepared will be better. Notice the deep tubelike depression

in which the hair rests, and the little knob embraced by the hair at its bottom. Notice the whitish cells of the sebaceous glands reaching off from the side toward which the hair points. Underneath the gland will likely be seen the faint outlines of the small muscle which causes the hair to stand on end.

114. A specimen of nail under the microscope will appear almost transparent, but the papillæ of the skin and the young epithelial cells beneath it will show well.

115. Wash a boy's arm. Then apply a cloth wet in hot water for a few minutes and show how the softened epithelium can be rubbed off. Explain that it is not dirt, but the protection of the arm.

REVIEW TOPICS

1. Describe the skin, its derma, epidermis, subcutaneous tissue, and coloring matter.
2. Describe the modifications of epidermis in a callous spot and a corn.
3. Describe freckles; a blister; an ulcer.
4. Describe the papillæ.
5. Describe a hair, sebaceous glands, and blackheads.
6. Describe the nails.
7. Give the causes and treatment of a bad complexion, and the effects of paints and powders and drugs.
8. Give simple directions for the care of the hair.
9. Give simple directions for the care of the nails.
10. Give a general rule when to bathe for cleanliness.
11. State the effects of a hot bath, and when to take it.
12. State the effects of a cold bath, and give a simple and easy way of taking one.
13. Describe a Turkish bath, and give reasons for not soaking and rubbing the skin to an excessive degree.
14. Give an easy way of bathing a feverish person.

CHAPTER XXVIII

NERVES

477. Uniformity of cell action.— Certain cells forming the *nervous system* are set apart for purpose of commanding the rest to work in the proper time and manner. The commanding cells, called *nerve cells*, form the essential part of the brain and spinal cord. From them as a center, fine threads called *nerves* run to the cells of the body. The outer end of each nerve thread touches a company of cells and carries to them the orders from the central nerve cells. Although each cell in the body lives and acts independently of the rest, yet the central nerve cells cause all to act in harmony.

478. Nerves.— Each nerve thread is composed of a central fiber surrounded by a protective layer of a kind



A nerve thread ($\times 400$).

a central conducting fiber.

b covering of fat.

of fat. The whole thread is only about $\frac{1}{4000}$ inch in diameter. Those which

go to each part of the body, as a hand or leg, run together in a bundle, which divides into its separate threads upon reaching its destined part. Each bundle of nerve threads is usually called a *nerve*. The main nerves of the arms are about the size of knitting needles, while the great sciatic nerve of the leg is as large as the end of the little finger.

As a general rule, a large nerve accompanies an artery down the inside of each limb and across the center of joints upon the side toward which the limb is bent. Thus they are in protected positions. One nerve cord is situated on the inside of the back of the elbow joint and is called the *funny bone*. Owing to its unusual position, it is sometimes hit, producing a pain in its ending on the inside of the hand.

479. Nerve action.—When one of the main nerves of the arm is irritated, as by a pinch or prick, or shock of electricity, an impulse is started along the nerve in each direction. It goes to the brain and produces a *sensation* either of pain or pleasure. It also goes to the muscle cells of the arm, causing them to contract and move the arm. If a nerve is cut and the end nearest the brain is irritated, a sensation will be felt, but there will be no motion. If the other cut end is irritated, the muscles will move the arm, but no feeling whatever will be produced.

Whether the nerve be irritated at its outer endings at the cells or anywhere in its course, an influence will travel to the central nerve cells carrying the news, and also in the opposite direction to the cells of the body, causing them to act. The cells of the body can originate influences which travel up the nerve to the central nerve cells; and, on the other hand, the nerve cells can originate influences which travel to the cells of the body and cause them to act. *Transmitting impulses* is the essential duty of nerves. They may be compared to telephone wires which transmit any kind of electrical influences over

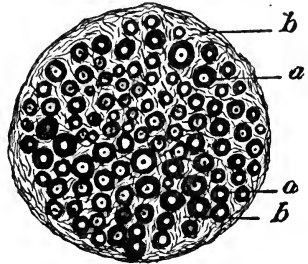

A thin slice from the end of a cut nerve ($\times 200$).

a nerve thread.

b connective tissue binding the threads into a cord.

their whole length without affecting anything in their course.

480. Kinds of nerves. — Each thread of a nerve transmits influences in only one direction. Some threads carry influences only from the cells of the body to the central nerve cells. Because they often produce sensation they are called *sensory* nerves. Other threads carry orders for action from the nerve cells to the cells of the body and are called *motor* nerves. Most nerves are made up of both sensory and motor threads, but some are wholly sensory and others wholly motor. There is no difference in their appearance.

481. Distribution of sensory nerves. — Nearly every cell in the body, except in the epidermis and blood, is probably in connection with a sensory nerve, and, through it, is in touch with the central nerve cells. The endings of the nerves are so abundant in the skin just beneath the epithelium, that the point of a fine needle cannot be thrust in without producing pain. In the ends of the fingers they are more numerous than in any other part of the body. The muscles and internal organs have fewer sensory nerves than the skin, so that a cut may be continued into the deeper parts with but little pain.

482. Kinds of sensations. — The cells are continually sending impulses to the central nerve cells telling of their needs, as of food or rest. These impulses often give rise to feelings which may seem to pervade the whole body. Then they are called *common sensations*. Some are pleasant and some are disagreeable. The natural unreasoning inclinations to gratify desires aroused by the needs of the body are *instincts*.

When something outside the body is acting upon the nerves it produces a feeling or impression of which a person is usually aware. By means of these sensations the mind forms definite ideas of the surroundings of the body,

and so the feelings are called *special sensations*. Unlike common sensations, the meaning of the sensations must be learned.

483. Common sensations. — Hunger, thirst, and fatigue are the usual common sensations felt by the mind. Hunger seems to be located in the stomach. If a substance swallowed is not nutritious, hunger soon returns, even if the organ is filled full. On the other hand, if nutritious food is introduced into the body through the intestine, the feeling of hunger will pass away, even though the stomach remains empty. Some persons suffering from indigestion are always hungry, though they eat enormously. But the food is not digested, and does not reach the cells, and there is always a feeling of hunger.

Thirst seems to be located in the mouth. Moistening the mouth allays it but for a moment only, while if water is introduced into the intestine or veins, the thirst disappears, even though the mouth receives no water.

The amount of common sensations is small compared with similar impulses which we do not feel. Every cell is continually sending tiny messages of its needs, and the central nerve cells promptly respond.

484. Special sensations. — Knowledge of the outside world is gained by means of the touch, sight, hearing, smell, and taste. Of these, touch is located in all parts of the body, while special organs are needed to enable the nerves to catch the delicate impressions of sight, sound, smell, and taste.

485. Sensations of touch. — When an object touches the epithelium of the skin, it causes an impulse to travel to the central nerve cells as a sensation either of touch, temperature, pain, or weight. All these sensations are included under the general term of *touch*. Touch proper

is a slight sensation caused by contact of the skin with an object. By means of it such ideas as those of shape, smoothness, size, and dampness are gained.

Different parts of the body vary greatly in the ability of their nerves to detect slight differences between two sensations. Thus the ends of the fingers distinctly feel two points $\frac{1}{2}$ inch apart as separate points, while if two points are applied to the back, they seem as one point until they are separated two inches. So we naturally use the ends of the fingers to feel with.

486. Sensations of temperature.—In the skin special nerves seem to end in minute points which are situated from $\frac{1}{16}$ to $\frac{1}{8}$ of an inch apart. When these are touched, a sensation of heat or cold is felt, while the skin between feels only a touch or pain. Some spots give a sensation of cold only, and others of heat only.

Sensations of extreme heat or of extreme cold cease to be feelings of temperature, but are felt only as pain. The skin is so sensitive that it can detect a difference of $\frac{1}{3}$ of a degree of temperature between two objects.

487. Painful sensations.—A sensation of touch or of temperature, if greatly increased or often repeated, becomes unpleasant and is called a *pain*. The same sensation may be felt at one time as a pleasant touch and at another as a pain. When an influence is becoming great enough to endanger the body, it arouses the nerves of pain and produces a strong and unpleasant feeling which overpowers the simple sensation of touch and compels us to withdraw from the danger. Pain is a protection for the body and not altogether an evil or a punishment. When the nerves of pain in an arm or leg are diseased, the limb may be burned beyond recovery without a person's knowledge. In many diseases pain is a prominent symptom, and the physician is besought to give it relief. Yet he

hesitates before giving morphine, knowing that to relieve the pain is to mask the danger signals so that he cannot judge of the real cause of the trouble.

Tickling is a sensation between touch and pain. It is produced in parts which are poorly supplied with nerves of touch, as on the back or the neck. At first, tickling is a pleasant sensation, but if continued, it becomes extreme suffering. Some persons and animals who are able to endure great pain are unable to control themselves when tickled.

Itching is a sensation which is overcome by producing a greater sensation in the part, as by scratching. Although itching is usually only an annoyance, in a greater degree it is a torment even worse than pain, and may lead a person to injure the skin seriously by deep scratching.

488. The muscular sense. — Sensations of weight or of resistance are judged partly by the amount of muscular effort needed to move the body, and so depend in large part upon the motor nerves. But the feelings of pressure upon the body and of muscular effort aid in producing the sensation. An object lifted seems distinctly heavier if its weight is increased only $\frac{1}{17}$, while if it is placed upon the skin, its weight must be increased $\frac{1}{3}$ before it feels heavier.

489. Necessity of epithelium. — The covering of epithelium not only protects the nerves from injury, but also modifies an impulse which produces a sensation, so that it is spread over a larger area of nerves and is made a gentle instead of a painful sensation.

490. Motor nerves. — Besides touching a sensory nerve, each cell probably communicates with a motor nerve also. Motor nerves begin at the central nerve cells and end at the cells of the body. Over them the central nerve cells send orders based upon information brought by the sensory nerves. Many orders are sent by willful efforts of a person, but by far the most are sent without our knowledge.

Motor impulses are of three kinds,—for motion, for secretion, and for growth.

491. Impulses producing motion.—The action of every muscle cell depends upon an impulse brought from the central nerve cells by its motor nerve. When these influences are cut off, there is *paralysis* of the part, so that no amount of willful effort can cause the muscles to move the limb. The peristalsis of the intestine and the beating of the heart are caused by influences brought to their muscle cells by motor nerves. Orders for movements of which we know nothing are far greater in amount than those sent to voluntary muscles.

492. Impulses producing secretion.—Secretion is also dependent upon orders brought to the glands by motor nerves. For example, when food is taken into the mouth, the sensory nerves carry the news to the nerve cells, which at once send out an order along the motor nerves to the salivary glands to produce more saliva. If the nerves are cut, only a little saliva will be produced, while if the end in connection with the gland is irritated, the gland will respond with a greater quantity of saliva. In the same way the secretion of all glands is controlled.

493. Influences producing growth.—When the motor nerve to a part is cut, the cells will be inactive, and, as it were, too lazy even to eat. So, unless continually under the influence of motor nerves, the cells become weak and waste away. When the cells of a part are much used, impulses are sent causing them to take in more nourishment, so that they increase in size and strength. Thus a muscle becomes larger and stronger by use. During the action of a muscle its motor nerves also bring orders for the arteries to dilate and carry more blood to feed the working part.

494. Rate of transmission of nerve impulses. — Ordinary sensations travel about 100 feet per second. This is about the rate of the fastest express trains, but our arms are so short that pain seems to follow an injury instantly. In some diseases the rate is very much retarded, so that if the hand should happen to rest upon a hot stove it would be badly burned before the sensation would travel to the brain and give warning of the danger.

495. A sensation traveling over a nerve seems to come from its beginning. When the funny bone, or nerve that winds around the back of the elbow, is pinched, the little finger side of the hand, where the nerve ends, feels as if pricked by needles. When an arm or a leg is cut off, and the nerves in the stump are irritated, a pain is felt which seems to be in the lost limb. When a nerve is pressed upon, it may be partly paralyzed for a while. Then the part which it supplies becomes less sensitive and is moved with difficulty. At the same time an impulse caused by the irritation of the pressure produces a sensation which seems to the brain to come from the end of the nerve. Thus when sitting crosslegged the foot often seems asleep and full of needles, while it is itself insensitive when touched.

A cut nerve will become whole again, but it takes some weeks. In the meantime the parts supplied by the nerve cannot feel or move.

496. Diseases of the nerves. — Nerves may become inflamed, producing the disease called *neuritis*. Then there will be great pain and tenderness over the entire course of the nerve. In severe cases there will be paralysis and loss of feeling. The disease is very slow in its course.

Sciatica is a mild but painful form of inflammation in the main nerve of the leg. Inflammation of the nerves may be caused by rheumatism or malaria, but, above all, by alcohol.

497. Effect of alcohol upon nerves. — A little alcohol seems to hasten the rate of transmission of nervous impulses by increasing the circulation of the blood, but a few drinks retard their action. A great danger of using alcohol is that it may cause *neuritis* or inflammation of the nerves. Slow, steady drinking may produce it as well as occasional sprees. It comes without warning, but remains a long while, producing pain and paralysis. Alcohol produces the disease as often as all other causes combined.

SUMMARY

1. The cells of the body are made to act harmoniously by means of orders sent from a few cells in a *central nervous system*.
2. A nerve is a bundle of microscopic threads, each running from a central nerve cell to the cells of the body.
3. Nerves transmit impulses caused by irritation from outside the body, and also impulses originated in either the cells of the body or the central nerve cells.
4. Sensory nerves carry from the cells news concerning a substance which is touching the body, and they inform the central nerve cells when the cells are tired or are in need of food.
5. Motor nerves carry orders to the cells to move, to secrete, to eat, and to grow.
6. Impulses in nerves travel about 100 feet per second.
7. Nerves may become inflamed and produce pain and paralysis.
8. Alcohol often produces severe inflammation of the nerves.

DEMONSTRATIONS

116. Skin the leg of a small animal or frog, and push apart the muscles upon the inside of its upper part. White nerve cords will be seen to lie alongside the main artery and vein, and can be traced upward to the spinal cord and downward until they become lost in the skin or muscles. Notice that those which branch off to the skin are as large and numerous as those which supply all the rest of the leg. Notice how much force is needed to break one of the nerves. In ancient times it was supposed that tendons and nerves were the same. Compare a nerve with a tendon to see their points of resemblance.

117. To show the effect of irritating a nerve in its course, pinch a boy's funny bone. He will wonder how the sensation travels to the

brain when he feels it go down to his little finger. Explain that it only seems to come from the finger, but does not go there.

118. With a power of at least 200 diameters, show specimens of a nerve mounted for the microscope. In a specimen of nerve cut lengthwise, notice the slender conducting fiber running down the middle of each thread and its thicker, clear covering of fat. In a specimen cut across the nerve, notice that the conducting fiber of each nerve thread appears as a central dot within a circle of the protecting fat. Notice the fine connective tissue between the threads. Sketch the specimen.

119. Show the difference in sensibility of different parts of the skin by touching it with the points of a pair of compasses. Upon the balls of the fingers the points will seem separate even if near together, while upon the back they will seem one when separated two inches.

120. Show that some parts of the skin feel sensations of temperature more than the others by drawing the point of a lead pencil slowly across the cheek. At intervals there will be felt a cold sensation, showing that a special nerve of temperature has been touched.

121. Cut a nerve in a recently killed frog and separate it from the flesh for a short distance. After a moment, pinch the nerve, and the muscles will contract.

REVIEW TOPICS

1. Describe the essential parts of the nervous system.
2. Describe a *nerve*.
3. Explain the two results of irritating a nerve.
4. Define and name the kinds of sensory impulses.
5. Describe the sensations of touch, pain, temperature, and weight.
6. Tell how the cells make known their wants.
7. Show how epithelium aids the sense of touch.
8. Name and describe the three kinds of motor impulses.
9. Give the rate of transmission of impulses along nerves.
10. Describe the effects of pressure upon a nerve; of cutting a nerve; and of disease of a nerve.
11. Tell how alcohol affects a nerve.

CHAPTER XXIX

THE SPINAL CORD

498. The first collection of central nerve cells is in the spinal cord. The spinal cord is a soft white cylinder of nervous tissue, about half an inch in diameter. It is securely hung in the upper two thirds of the tube formed by the bony rings of the backbone. It extends from the bottom of the skull to about the level of the lowest rib, a length of about eighteen inches. It is only about two thirds as large as its tube, and so is not likely to be injured by bending the backbone.

499. The gray matter. — When the cord is cut across, the central part of its end shows the grayish outline of a butterfly surrounded by a

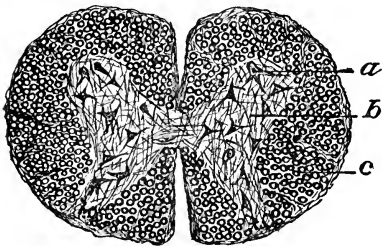

A thin slice from the spinal cord with the cells and nerves magnified 200 diameters.

- a cells in the gray matter.
- b fibers in the gray matter.
- c nerve threads in the white matter.

thick layer of a whiter substance. The gray matter is a collection of *nerve cells*, which give off numerous nerve fibers like the central fibers of ordinary nerve threads. The cells are about $\frac{1}{1000}$ of an inch in diameter. Some of the nerve fibers communicate with other cells

of the cord, and some take coverings and become ordinary nerve threads. The whole is bound together by delicate connective tissue.

The spinal cells receive a part of every impulse from the sensory nerves, and take part in sending out motor impulses to the various parts of the body.

500. The white matter. — The white matter is made up of nerve fibers which still retain their coverings. In fact, the white matter is simply a huge nerve. The nerve threads of the white matter adjoining the right and left sides of the gray matter are motor threads carrying im-

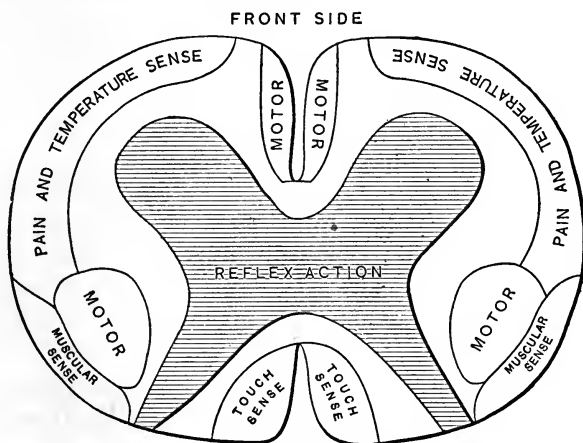

Diagram of the action of each part of the spinal cord.

pulses from the brain to the cells of the gray matter. The nerve threads outside of these and the threads behind the gray matter are prolongations of the sensory nerves of the body, some of which finally go to the brain, and others connect with the cells of the gray matter of the cord.

501. Spinal nerves. — The spinal cord gives off thirty-one pairs of nerves through openings between the rings of the backbone. Each nerve is made of a sensory and of a motor part which soon unite into a single bundle in which the two kinds of nerves cannot be dis-

tinguished. These spinal nerves supply the whole body below the neck.

502. Action of nerve cells in voluntary motion. — The spinal cells do not originate impulses or act of their own



Diagram of the origin of nerves in the spinal cord.

- a* motor nerve root from the front part of the nerve.
b sensory nerve root from the back part of the cord.
c gray matter of the cord.
d white matter.

accord, but they act only when ordered to do so by the brain or when the cells of the body express a need of protection, nutrition, or rest. When a person wishes to lift his hand, his brain sends an order to these nerve cells, and they in turn send the order over the nerves to the muscles which

move the hand. In this way the mind sends all orders for voluntary motion. For each muscle there is a separate group of spinal cells. If these cells are injured or destroyed, a person cannot move his muscles voluntarily.

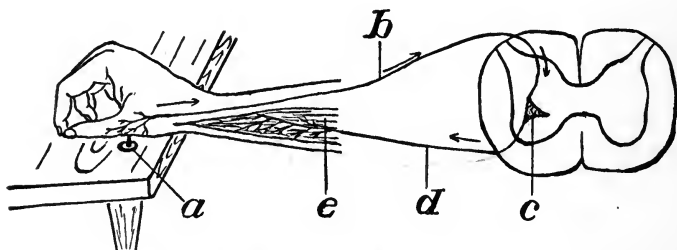

Diagram of reflex action.

- a* tack pricking the hand. *b* sensory nerve. *c* nerve cell in the spinal cord.
d motor nerve. *e* muscle moving the hand.

503. Reflex action. — The spinal cells also send out orders in response to impulses brought by sensory nerves. Motor impulses sent in response to influences brought by

sensory nerves are *reflex acts*. Reflex action is designed to protect the body from injury and to supply its needs. Most acts of the cord are reflex. When the finger touches a hot object, the sensory nerves carry the sensation to the cells of the spinal cord and to the brain. Before the sensation reaches the brain, the spinal cord sends out an order for the muscles to move the finger away from the heat. The brain becomes conscious of the burn and of the movement of the finger at about the same time. In this way the spinal cord protects the body against all kinds of injuries.

504. Reflex action in relation to nutrition.— Digestion is mainly a reflex act. Motor impulses for glands to produce the digestive juices are sent out from the spinal cord when the sensory nerves bring word that food is present in the stomach or intestine. Peristalsis is also a reflex act dependent upon the presence of food. The sensory nerves also carry to the spinal cells news of the temperature of a part and of its need of more or of less blood, and, in response, the cells send out motor impulses for the arteries to change their size. The heart is also somewhat affected in a reflex way. The sensations of exertion and fatigue are carried to the spinal cells, which send out orders for more rapid heart beats. Fear, joy, anger, and sorrow all affect the heart in a reflex way.

The growth of each separate cell is controlled by the same set of spinal cells that produce motion in a part. Muscle cells, especially, need the constant stimulus of the spinal cells to keep them growing, for otherwise they slowly waste away and become weak. The spinal cord is continually overseeing the nutrition and growth of cells, and if it were to cease its oversight, their death would soon take place.

505. Reflex action in habitual movements.— The reflex action of the cord aids in performing simple movements of

the body. The peculiar sensations which tell a man that he is beginning to fall pass to the cells of the cord, and they in a reflex way send out the proper orders for the muscles to put the body in an upright position again.

506. Reflex action in education. — The reflex action of the spinal cord can be educated. Even a simple reflex action like standing must be learned. When a baby first tries to walk, his brain cells give the proper orders to the cells of the spinal cord, and they in turn give them to the muscles. Thus he slowly directs each detail of the movements with his brain. Soon the spinal cord learns to send the next order as soon as it feels the sensation of the previous movement, and finally all the movements needed become reflex, and the child runs about with but little effort on the part of his brain.

In learning to play a piano, the brain is occupied both in reading the notes and directing the movements of the fingers in playing. But, at last, the brain has only to read the notes to the cord and it instantly sends the proper orders that they be played.

Education and skill in any art consist in the ability of the cord to execute proper movements while the brain is wholly occupied with the design. In this ability to acquire new uses, the cells of the nervous system differ from all other cells of the body. When the hand is educated, it is really the spinal cells which are educated.

507. Excessive reflex action. — Reflex acts are sometimes not beneficial. A slight noise gives some people a fright, and in lockjaw the slightest sensation causes the spinal cells to send out orders for the muscles of the body to contract violently. Self-control is largely the power which the brain has of restraining the spinal cells from sending out orders even when strong and sudden sensations are received. Thus, when something tickles the throat, it is possible for the brain to restrain the spinal

cells from sending the order to cough. In the same way men sometimes endure great pain without shrinking.

508. Broken back. — Injuries to the backbone may injure the spinal cord so that it cannot conduct nervous influences past the injured point. Then parts of the body below the point of injury can neither send nor receive messages from the brain, but are paralyzed both in sensation and motion. Yet the reflex action of the part may persist, for the part of the cord below the injury still retains its vitality.

509. Disease of the spinal cord. — There are diseases which may destroy the action of any single part of the cord or of the whole cord below the seat of the disease. Then there will be loss of sensation or of motion or impairment of nutrition, usually in the lower part of the body. The diseases are generally slow in their course and incurable.

510. The action of the cord is unconscious. — The cord always acts wholly without a person's knowledge. Like a faithful nurse, it stands guard over the cells of the body and controls them in their nutrition, growth, and work. The brain restrains its excessive action and directs it in ordering the voluntary movements, but leaves to it almost the entire care of individual cells.

SUMMARY

1. The spinal cord is made up of a central mass of gray matter surrounded by white matter.
2. The gray matter is made up of cells from which nerve fibers extend both to the brain and to the cells of the body.
3. The white matter is composed of nerve threads which connect the cells of the cord with the brain and with the nerves of the body.

4. Thirty-one pairs of nerves connect the cord with all parts of the body.
5. The use of the cells is to send orders over the motor nerves when told to do so by the brain, and also to send orders in response to information brought to them by sensory nerves.
6. Orders sent in response to sensations are reflex acts.
7. Reflex acts are for protection, nutrition, and to relieve the brain from the drudgery of sending orders for every detail of bodily movements.
8. The reflex action in an educated spinal cord enables a person to work with skill.
9. Restraint of excessive reflex acts constitutes self-control.

DEMONSTRATIONS

122. Procure a spinal cord at the butcher's. Notice the nerves going off from the cord. Notice how the cord is enveloped by a thick, fibrous sheath and is held in place by the nerves and fibrous bands. Remove the cord from the bone and slit open its sheath. Notice the soft consistency of the cord and its shape like two cords pressed together. On its clean-cut edge notice the grayish butterfly-shaped center and the pure white outer part.

123. Examine a thin cross section of the cord under the microscope with at least 200 diameters. In the outer parts of the specimen notice the round circles of cut nerve threads. Explain that this is the white matter of the cord.

Examine the central part, noticing the large nerve cells and nerve fibers which run in all directions. Notice the fine and wavy connective tissue fibers binding the whole together.

124. The pure reflex action of the cord can be shown with a decapitated frog. Place a small piece of blotting paper, wet with a strong acid, upon its back, and it at once kicks it off with its hind leg. Prick its back, and it makes one leap. Suspend it with its hind legs hanging down, and let a toe touch a dish of acid, and it at once draws up the leg. (See demonstration 35.)

Explain that the frog has no feeling or sense, but performs the move-

ments in a reflex way to escape danger in the same way that a boy suddenly jumps when he touches a sharp pin.

125. To show reflex action, have a boy sit with one knee crossed over the other and hanging perfectly limp. Now strike the front of the knee just below the patella. The thigh muscles will contract and cause the leg to kick. This will succeed best if the boy is not looking when you strike.

REVIEW TOPICS

1. Describe the spinal cord; its appearance and situation; its gray matter, its white matter, and the origin of the nerves which arise from it.
2. Describe how the cells of the gray matter act in causing voluntary movements, and in causing reflex movements.
3. Explain how reflex action is a protection to the body; how it controls all processes of the growth and secretion of the cells; and how it enables a person to acquire skill in movements.
4. Explain how reflex acts may be harmful; how self-control may overcome the harm.
5. Describe the effects of injury to the spinal cord.
6. Describe the effect of diseases of the spinal cord.

3/28/22

CHAPTER XXX

THE SYMPATHETIC NERVOUS SYSTEM

511. Of what the system consists. — The spinal cord controls the contraction of the arteries, the peristalsis of the intestine, and the growth of cells. Yet the impulses which it sends out for these purposes pass through another set of nerve cells and nerves called the *sympathetic nervous system*.

The sympathetic nervous system consists of small bodies like grains of corn or smaller, called *ganglia*, from which nerves go out in all directions. There are four main pairs of ganglia in the head, and twenty-three in a row down the front of the backbone all connected by nerves. Each ganglion is a collection of nerve cells and nerve fibers bound together by connective tissue. Nerve threads connect its cells with the cells of the spinal cord and also with the muscle cells of the arteries and intestine. Through the arteries they probably affect all the cells in the body. The nerve threads are smaller than those of ordinary nerves, and seldom form bundles large enough to be seen. They usually consist of a fiber like the central fiber of an ordinary nerve thread without its fatty covering. They are thus not easily found even with the aid of a microscope.

The nerves from the ganglia run mainly along the course of the large arteries. Upon the aorta and its

main branches in the chest and abdomen, nerves and small ganglia form intricate networks, each called a *plexus*.

Just back of the stomach there is a large and important plexus called the *solar plexus*, whose nerves supply the muscles of the organs of the abdomen. A plexus within the heart controls the action of the heart.

512. Sensory sympathetic nerves. — The sympathetic nerves carry both sensory and motor impulses, but only faint impulses of pain and touch. Thus the circulation of the blood and digestion of food go on almost without our knowledge, but a very strong irritation may give rise to an abdominal pain, as in colic.

Sensory impulses telling of the wants of the cells and of the need of secretion or movements of the arteries or digestive organs are continually being received by the ganglia. These impulses travel slowly and require some time to produce an impression. Most of them travel only to the cells in the ganglia, and few get farther than to the cells in the spinal cord. Only very strong impressions, whose cause may injure the body, reach the brain and produce a feeling of pain, hunger, thirst, or fatigue.

513. Motor sympathetic nerves. — The ganglia send orders to the epithelial cells of the glands to produce their secretions, and to the muscles of the intestine and arteries either to contract or to dilate. They do this in response to information furnished by the sensory nerves. They also send out orders for the growth and nutrition of the cells of the body on receipt of news of their needs. Most orders from the ganglia are reflex.

514. Mode of action of the ganglia. — If cut off from connection with the cord, the ganglia send few impulses. The cord seems to furnish them with a supply of nervous energy. They seem to take a small amount of its active impulses and transform it into a large

amount of gentle impulses for the arteries and intestine. When poisons or spoiled food irritate the intestine to a dangerous degree, the sensation goes beyond the ganglia and excites the spinal cells to action. In response they send out direct orders which cause energetic and painful peristalsis to remove the food, in marked contrast with the gentle action caused by the ganglia alone.

515. Influence of the brain. — The brain has some power over the ganglia. Excitement or fear may influence the spinal cord so that it in turn modifies the impulses going through the ganglia. Sorrow seems to depress the ganglia so that the processes of digestion and assimilation are not so well performed, and the nutrition and growth of the cells of the body are diminished. But nature has arranged that after leaving the brain, mental influences shall act through two sets of nerve cells before they can directly affect the nutrition of the body. Thus man's body is protected against injury from his ever-changing moods.

516. Connection of organs with each other. — By means of the sympathetic system, a nervous influence in one organ is spread over all the rest. Because other organs seem to share in the sickness when one is deranged, the nerves controlling them are called *sympathetic* nerves. Thus, when one organ is deranged, the others act less strongly and impose less work upon the disabled part.

517. Injury to sympathetic nerves. — The sympathetic nerves are less influenced by outside impressions than any other nerves in the body, and great violence is needed to impair their action seriously. Poisons which are swallowed or produced during disease may injure them so that the ganglia almost cease to send out their orders. Then life is endangered, and strong nerve stimulants like strychnine are needed.

Aside from poisons, almost the only grave danger which may threaten the sympathetic system is a blow upon the abdomen or neck. A hard blow or great pressure just below the ribs may paralyze the solar plexus. The arteries then enlarge and hold so much blood that too little goes to the head and brain. So there is danger of sickness and of death. A blow upon the side of the neck may injure

the large ganglia which are situated there, as well as the large nerves near by, and make such a profound impression upon the heart that death may take place at once. Blows upon the neck or abdomen are always dangerous.

SUMMARY

1. The sympathetic nervous system consists of collections of nerve cells called *ganglia*, and of both sensory and motor nerves which follow the course of the arteries.
2. The cells of the spinal cord send impulses to the ganglia, and they in turn distribute them to the arteries and glands and to the organs of the chest and abdomen.
3. The ganglia send orders only in a reflex way according to impressions received from their sensory nerves.
4. The ganglia control the contraction and dilatation of the arteries, the peristalsis of the intestine, the secretion of glands, and the growth of the cells of the body.
5. The ordinary sensory impulses conducted by the sympathetic nerves produce no feeling.
6. The heart is controlled mainly by a set of small ganglia within its own walls.
7. The sympathetic system produces slow and gentle movements in contrast with the quick and active movements made by the spinal cord.
8. The brain has no direct control over the ganglia.
9. Blows upon the neck or abdomen may injure the sympathetic nerves so as to cause death.

REVIEW TOPICS

1. Describe the sympathetic nervous system: its ganglia, nerves, plexus, and its connection with the spinal cord.
2. Describe the sensory impulses of the sympathetic nerves.
3. Describe its motor impulses and their relation to the arteries; to secretion of glands; to peristalsis; to the growth of cells, and to the heart.
4. Describe how the ganglia send out their impulses.
5. Describe how the spinal cord has influence over the ganglia, and how they work independently of the cord.
6. Describe how the brain can affect the ganglia.
7. Describe how the action of the ganglia may be seriously impaired by injuries.

CHAPTER XXXI

THE BRAIN

518. **General structure.**—The brain is the part of the central nervous system which can *originate* orders in distinction from the spinal cord, which acts only in response

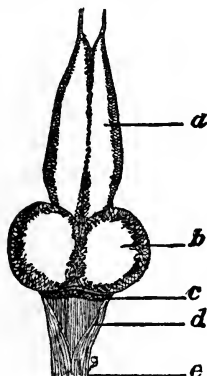

Brain of a frog; top view ($\times 10$).

- a cerebrum.
- b optic tubercles.
- c cerebellum.
- d medulla.
- e upper end of spinal cord.

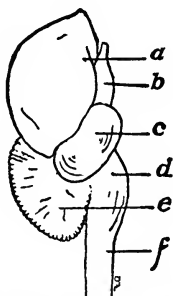

Brain of a hen; side view ($\times 2$).

- a cerebrum.
- b optic nerve.
- c optic tubercle.
- d medulla.
- e cerebellum.
- f spinal cord.

to impulses brought to it. In reptiles, toads, and frogs, it is very simple in structure, but yet contains parts corresponding to all the parts of the brain of man. In them the spinal cord swells out to form a cone-shaped body called the *medulla oblongata*. Above it there is a small flat

swelling called the *cerebellum*, the next two smaller bodies called the *optic tubercles*, and at the top two larger bodies which together are called the *cerebrum*. They follow each other in a straight line. In man the parts are bent upon each other, while the cerebrum is so large that it covers all the other parts.

519. Coverings. — The brain of man is a very soft body weighing about fifty ounces. It is contained in the top of the skull. It is covered with a delicate network of fibers called the *pia mater*, which carries the numerous blood tubes of the brain. Outside of the *pia mater* is a thick, tough membrane called the *dura mater*. The *dura mater* is the periosteum of the inside of the skull.

520. The medulla. — The upper end of the spinal cord becomes enlarged into a wedge-shaped body called the *medulla oblongata*, or simply the *medulla*. The medulla is about one inch and a quarter in length and three quarters inch in breadth at its upper end. Its center is gray matter covered with white matter, both of which are direct continuations of the same matter in the cord.

521. Nerves of the medulla. — From the medulla there go out seven pairs of nerves to supply the head and face. They, together with five other pairs which the brain gives off, are called *cranial nerves*, in distinction from the spinal nerves. The cranial nerves which arise in the medulla are sensory and motor, and supply the head and face just as the spinal nerves do the rest of the body. They connect with cells in the medulla which act only in a reflex way. In this sense, the medulla is a part of the spinal cord, and not of the brain. One of these seven cranial nerves is partly a nerve of the special sense of taste. Impressions of hearing, sight, and smell are carried by three cranial nerves arising higher up in the brain.

522. The vagus nerve. — One of the pairs of cranial nerves is called the *vagus*, or *pneumogastric*, nerve. It supplies a small sensory branch to the ear, and motor branches to the larynx and pharynx; then it passes into the thorax and gives off branches to the heart, which restrain its action. It gives sensory branches to the esophagus and lungs, and finally reaches the stomach and liver. The main nerve supply of these organs is from the spinal cord, or from the sympathetic system, but the vagus nerve is an additional means for better regulating their action to suit the needs of the body.

523. Centers originating impulses. — In the medulla, a collection of nerve cells, called the *respiratory center*, sends out a regular succession of orders for respiratory movements. While the orders may be hastened or retarded by other nerve centers to suit the needs of the body, yet the medulla compels the respiratory muscles to act so as to keep the body supplied with sufficient oxygen. Thus it is a real part of the brain. When the respiratory center is destroyed, respiration and life cease instantly.

There is another part of the medulla, called the *vasomotor* center, which controls the contraction of arteries, and another which regulates the peristalsis of the esophagus in swallowing. While these are partly reflex acts, yet their perfect action requires original impulses to be sent from the medulla.

524. Effects of reflex influences. — The respiration, circulation of the blood, and taking of food are essential vital processes of life which the medulla controls without our being aware of it. Strong influences from the nerves of the body may act in a reflex way to modify the impulses of the medulla. Great fear may cause the vasomotor center to send out impulses for the contraction of the arteries so as to produce great paleness. Instances have occurred in which the disturbance of circulation from this cause has produced death.

525. Effects of injury. — An injury to the respiratory and vasomotor centers causes death at once. A broken neck, if high up, may

involve the medulla and cause instant death. But the medulla is so situated that only the greatest violence can harm it.

526. The cerebellum. — Just above and overhanging the medulla is a rounded mass called the *cerebellum*. It forms less than one fifth of the brain. It consists of an interior

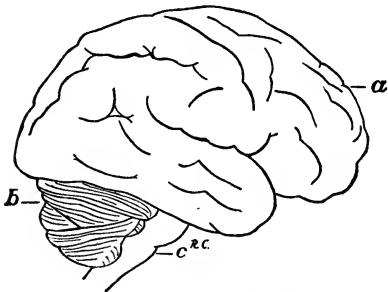

Diagram of a human brain.

a cerebrum. *b* cerebellum. *c* medulla.

white mass of nerve threads, covered with a layer of gray matter about $\frac{1}{15}$ of an inch in thickness. On the surface are deep fissures into which the gray matter dips, so that its amount is greatly increased. In the gray matter are nerve cells which are connected

with the rest of the nervous system through the nerves of its white matter. These nerve cells are the essential part of the cerebellum. They have no connection with any vital process of life, and do not take part in thought. A man with a diseased cerebellum can perform a single muscular act like raising his hand, but he cannot direct changing and complicated movements, such as are required in writing, walking, or balancing his body. Thus the cerebellum acts like a balance wheel, so that orders for complicated movements may be sent with regularity and precision.

527. The optic tubercles. — The optic tubercles are two small collections of gray matter situated upon the main nerve tracts which connect the cerebrum and medulla. They seem to be connected with the reflex movements of the eye. Other collections of gray matter near them seem also to be connected with the eye.

528. The cerebrum. — The main nerve tract, after passing through the spinal cord, medulla, and optic tubercles, spreads out to form a mass called the *cerebrum*. While in frogs and fishes it is no larger than the medulla or optic tubercles, in man it forms more than four fifths of the whole brain and overhangs all the other parts.

It consists of a central mass of nerve threads covered with a layer of gray matter one eighth of an inch in thickness, containing numerous large cells. Each cell gives off numerous fine fibers. Most of these fibers form an intricate network among the cells, but one from each cell takes a covering and becomes a nerve thread of the white matter, and finally reaches other cells of the brain or even of the spinal cord.

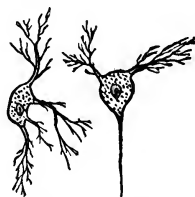

Cells from the gray matter of the cerebrum ($\times 300$).

529. Fissures of the brain. — The cerebrum is divided nearly into two parts, called *hemispheres*, by a deep furrow running forward and backward upon the middle of its upper surface. Another furrow, called the *Sylvian fissure*, starts near the bottom of the fore part of the side of the cerebrum and runs backward and upward. Many other furrows and fissures from one quarter to one half inch in depth, run in waving lines between its main furrows, throwing its surface into folds called *convolutions*. The convo-

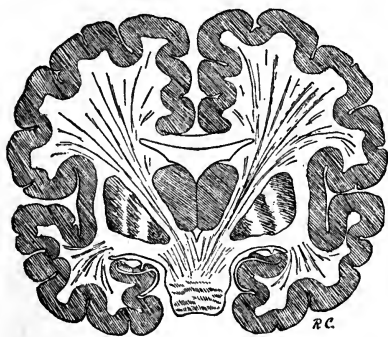

Human brain cut crosswise.

lutions increase the surface of the cerebrum, so that in all it measures about four square feet. This greatly increases the area over which the nerve cells in the gray matter may be spread. The interior of the cerebrum is a small irregular cavity, called the *ventricle*, which is filled with a clear liquid.

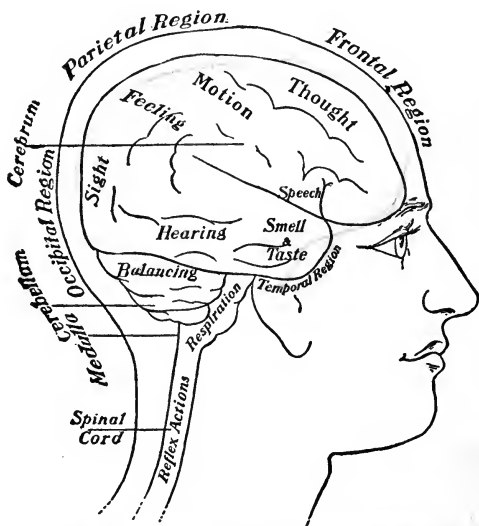

Regions of the head and action of the different parts of the brain.

530. **Regions of the cerebrum.** — The fissures and convolutions are nearly the same in all men, and mark out definite regions upon the surface of the brain. First, is the region just behind the forehead, called the *frontal region*. Second, is the region lying under the upper part of each side of the skull, and called the *parietal region*. Third, is the region about the ear, called the *temporal region*. It lies just above and in front of the ear. Fourth,

that part of the brain lying under the back of the skull is called the *occipital region*. Each region of the brain does a special work.

531. Action of the cerebrum. — The nerve centers may act reflexively in response to sensory impulses, as the spinal cord usually does; or automatically by originating their own impulses, like the respiratory center in the medulla and the nerve cells in the heart. The spinal cord, sympathetic system, medulla, and cerebellum all act in one or the other of these ways, and without our being conscious of their action. The cerebrum is the seat of the thinking mind. It acts in an automatic way, but we may be conscious of any of its actions. It acts first by feeling sensations; second by sending orders for voluntary muscular movements; third, by thought. It does each kind of work in a particular region of its surface.

532. Sensory regions. — Sensory impressions of which we are conscious are *sensations*. Sensations of hearing, smell, and taste are felt by the temporal region; of sight by the occipital region; and of touch by the parietal region. If either region is destroyed, the impressions going to that area are no longer received, and the person is devoid of the corresponding sense. Unless each impression reaches its own region of the surface of the brain, it produces no sensation, although it may still reach reflex centers in the optic tubercles, medulla, or cord, and give rise to reflex action.

533. Memory. — Impressions may be retained in the cells and be recalled. These constitute memories. Our memories are complex stores of impressions in widely separated parts of the brain. The sum of our different memories constitutes a great part of our *knowledge*.

Different regions of the brain are connected by nerve fibers. So when one region recalls a memory, another

region recalls another memory of the same object. Thus, when the temporal region recalls the memory of a sound of a bell, the occipital region recalls its appearance.

534. Motor regions. —

Orders for voluntary motion are sent by the cells lying just in front of a zone connecting the two ears. Each muscle of the body is controlled by a special set of nerve cells called its *motor center*.

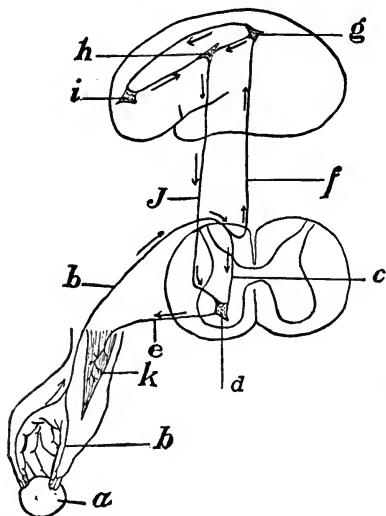

Diagram of the course of nerve influences in voluntary motions.

- a* object to be picked up.
- b* sensory nerve.
- c* the part of the influence which goes to the cells of the cord, and tends to produce reflex action.
- d* cell of spinal cord.
- e* motor nerve from spinal cord.
- f* continuation of the sensory nerve *b* up the cord to the brain.
- g* cell of the brain which perceives touch.
- h* motor cell.
- i* thought cell.
- j* motor nerve fiber running to the cells of the cord, and carrying an influence which continues along the motor nerve *e*.
- k* muscle which moves the hand.

A motor impulse passes down through the white matter of the cerebrum, medulla, and spinal cord to the spinal nerve cells, and then out along a motor nerve to a muscle. In an injury or disease in the top of the skull some of the cells of the motor region may be involved, giving paralysis of certain muscles. By the muscles affected one can often judge of the exact location of the trouble and remove it by an operation.

535. Relation of the sensory to the motor regions. —

The motor and sensory regions are in close connection by nerve fibers in the white matter. The motor region regulates its impulses according to information brought

to sensory regions by sensory nerves. A carpenter regulates the force with which he pushes his plane according to the feeling of muscular resistance.

536. Memory of movements. — Acts of motor cells are stored in memory and constitute a part of knowledge. All motions must be learned at first. When the brain centers have learned a movement thoroughly they teach the spinal centers so that finally their work is almost entirely relieved, and they can be occupied in other thoughts. Awkwardness is usually the result of the brain's attempting to send out orders for motion while it is occupied with other thoughts. Ease and grace of motion come when the spinal centers have learned to relieve the brain center.

537. Thought regions. — The cells of the frontal regions take note of memories stored in other regions, and by their comparison form new ideas. Thus, a pause between two sensations or mental acts gives rise to an idea of time; and the sight of two objects removed from each other gives the idea of space and of number. Neither time nor space nor number in itself can make an impression upon the senses, and yet they are realities in the mind. Comparison of memories and the formation of new ideas is *thinking*. Thoughts themselves are stored in memory and can be recalled and compared.

538. Speech. — Thought is expressed by speech. By means of speech new sensory and motor ideas and new thoughts are gained and stored in the memory without the cells of the different regions experiencing the particular sensations. Herein is the main difference between a man and an animal. An animal gains new ideas only by memory of its sensations and acts which it itself experiences, but a man can acquire them second hand by being told. Thus a man may be profited by the experience of

others. Knowledge gained only by long and patient research of wise men is imparted to children in a few moments, while an animal can impart knowledge only in a limited degree.

539. Speech in animals. — All animals have a variety of natural cries. Monkeys have a dozen separate cries which are similar in all species. A hen has at least five different cries to express as many different ideas. Parrots and crows have been taught to speak a few words, but they do it just as the mocking bird or brown thrush imitates any sound which it hears. Speech belongs to man alone.

540. Of what speech consists. — Speech is one of the highest and most complicated of mental processes. It is not a natural gift, but must always be learned at first. A child first hears a word spoken. He records it in the temporal regions of the brain, and learns to recall certain sensory and motor memories when he hears the word. By the time he is a year and a half old his motor region begins to form the word when he thinks of the memory. At the age of six or eight he begins to recognize the printed word with his sight region, and finally he learns to write the word with his motor region. Thus nearly every region in the brain takes part in some form of speech.

541. Center for spoken words. — The muscles of the mouth can be moved by the cells of the face center in the motor region, but their movements in speech are so precise and complicated that a center is especially provided to produce their movements in talking. It is situated just below and in front of the motor area, but is usually upon only one side. When this center is disturbed, a person cannot talk, although he understands spoken and written speech, and has control of his lips and tongue in doing other things.

542. Disturbance of the speech centers. — There are cases in which the word-seeing center is disturbed so that a person can

speak and write correct answers to questions, but cannot read and understand what he has just written. Sometimes a person cannot speak his thoughts, but can read aloud what he has written. Careful observation of the speech is of great value in locating brain diseases, for the speech centers involve nearly every region of the brain.

543. The Intellect. — The cerebral cells act in as definite and uniform ways as the cells of the intestine or heart, and men studied the laws of their minds long before the structure or even the existence of cells was known. The actions of the mind are divided into three great divisions. First, is the *intellect*, or the pure knowledge-gaining faculty. This includes the work of all the sensory regions of the brain and such a part of the frontal regions as is concerned in receiving knowledge through speech. It is the basis of the other mental acts.

544. The sensibilities. — The second division of mind study comprises the *sensibilities*, or the feelings. Much of knowledge does not concern us in the least. All feeling is based on knowledge, and all knowledge leads up to feeling as we come to know a thing intimately. We love it or hate it, and are sorry for its loss.

545. The will. — The third and highest act of the mind is to *will* to do. It is the control which the frontal region has of the motor region. In order to do a thing we must first have knowledge, and, second, we must feel some degree of emotion or desire to do it. Only a small part of knowledge causes feeling or emotion, and only a small part of even our strong feelings are expressed in action.

Of all the actions of the mind the will is the most difficult to arouse and control. Since it depends upon feeling, this faculty must first be aroused. Men readily act their feelings of anger and fear. To form a new will, active and brave, which is capable of controlling the natural and acquired appetites and passions, is the highest and noblest work of man.

546. Brains of animals. — The medulla is much the same in all animals from the frog up to man. This is because breathing and the flow of blood are much the same in all. The cerebellum in a frog or snake or fish is very small, for they need but a small regulating and balancing part. A bird or a hen must make precise movements in balancing itself in flying or roosting, and so it has a large cerebellum.

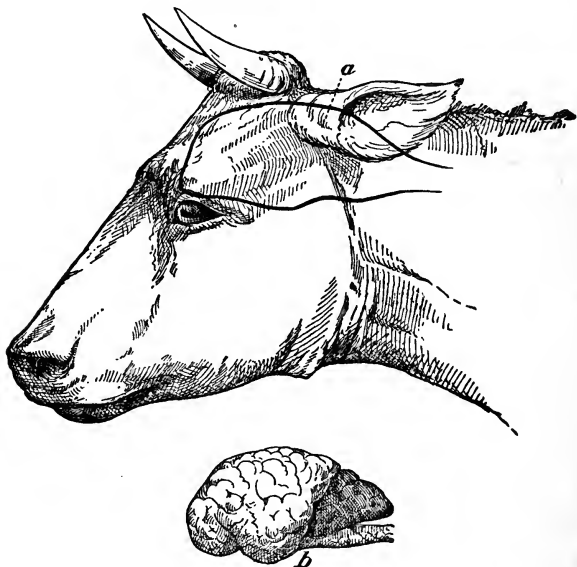

Brain of an ox.

a outline of brain in the skull. *b* the brain removed from the skull.

The optic tubercles of frogs and birds are well developed, for their eyes are perfect. The cerebrum of frogs and snakes and fishes is very small. Its hinder parts are the largest, for in them the impressions of sight, hearing, and smell are located. Its fore parts are mere points, as would be expected from the low intelligence of the animals. A bird has a larger cerebrum, corresponding to a greater mind. An animal's cerebrum is much larger and is somewhat folded to give room for more nerve cells, but the frontal or thought region is small. An animal's

senses are as acute as a man's, and so the back parts of its brain are well developed.

547. Animal intelligence. — An animal is capable of storing sensory and motor impressions in memory, and of sending out motor impulses according to sensory impressions. In some respects he is capable of doing this to a far greater extent than man. For instance, a dog can find his master by the sense of smell alone. He can also use his frontal region in thought and judgment, but to an extent which corresponds to the small size of this region.

548. The essential difference between man and animals. — The possession of speech seems to be the key to man's progress and noble ambitions. By means of it the Creator has revealed to him a knowledge of things before the foundation of the world, and of things to come. Animals are incapable of receiving instruction except through the senses and so they make no progress. Man rises in thought above time and space itself.

549. The nervous system in lower animals. — All four-footed animals, birds, fish, and reptiles possess nerves, a spinal cord, and a brain. Their nerves, sympathetic system, spinal cord, and medulla are developed nearly as much as in man, for the creatures eat, feel, move, and breathe, often to a greater extent than man. The cerebrum is developed according to the intelligence of the animal, and the cerebellum according to the complication of its movements.

Insects and worms and shellfish have no brain or spinal cord, but a row of ganglia like those in the sympathetic system extends through the body. Each ganglion gives off nerves to the cells of the body. These creatures do little else than eat and digest food, and hence the highest nervous system is not needed.

In the lowest form of life there is no nervous system at all. When the animal consists of a few cells or of only a single cell, no nervous system is needed.

SUMMARY

1. The brain is the part of the central nervous system which originates impulses.
2. The brain is continuous with the spinal cord, and consists of the medulla, cerebellum, optic tubercles.

and cerebrum. Each consists of gray matter containing nerve cells, and of white matter made of nerve threads.

3. The medulla is like the spinal cord in that it gives off sensory and motor nerves.
4. The medulla also originates impulses controlling respiration and the contraction of arteries.
5. The cerebellum adjusts the voluntary motor impulses of the brain, so that movements like balancing of the body are done with precision.
6. The optic tubercles are reflex centers for the eyes.
7. The cerebrum forms four fifths of the brain, and consists of a puckered covering of gray matter over a central mass of white nerve fibers.
8. The cells of each part of the brain have a definite work to do. They receive sensory impressions, send motor impulses, and think.
9. The impressions of each cell remain as permanent memories which can be recalled at will.
10. By means of speech, thought, sensory and motor impressions are conveyed to other persons and there become memories as though they had actually been experienced.
11. In speech the centers for motion, sound, and sight all take part.
12. There is a special center for producing the movements of the mouth in speech.
13. The first stage of mind action is knowledge; the next, emotion; and the third, willing and acting.

DEMONSTRATIONS

126. Show as types the brains of a frog or fish; of a hen; and of a fourfooted animal. A frog's, fish's, or chicken's brain can easily be

removed by cutting away the skull. After opening the top of the skull, place it with the brain in Müller's fluid or formalin for a few days, when the brain will be hard and can be removed with little injury.

127. In the frog, note the medulla, then the thin cerebellum, looking like a disk of paper with its edge inserted just above the medulla. Note the swelling optic tubercles, and then the long, pointed halves of the cerebrum.

Next compare the same parts on a bird's brain. Note the similar medulla and optic tubercles. Note the large cerebellum forming a half moon above the optic tubercles, and marked with cross fissures upon its back part. Note the cerebrum in front, shaped like a chestnut and as large as the rest of the brain.

Next compare the same parts in a mammal's brain. Note the similar medulla, but the larger cerebellum. The optic tubercles are obscured by the cerebrum. Note the cerebrum, large enough to cover almost all the rest of the brain. Note the convolutions.

Now compare these brains with a model or a picture of the brain of man. Note the large frontal regions in man and the larger and more numerous fissures and convolutions, and that the cerebrum completely covers all the other parts of the brain.

128. When the skull of an animal is opened, note the lining of tough and thick *dura mater*, which may be peeled off with little difficulty. Note that it extends in between the two hemispheres of the brain and between the cerebrum and cerebellum. Underneath it, note the delicate meshes of the *pia mater*, containing numerous blood tubes. Note that it dips into all the fissures and contains a small amount of a thin, clear fluid.

129. Examine a specimen of the gray matter of the cerebrum or cerebellum with a microscope magnifying 400 diameters. Note its nerve cells with fine branches. The white matter will appear like a collection of ordinary nerve fibers. Sketch the specimen.

REVIEW TOPICS

1. Name the different parts of a frog's brain in order, and tell how they differ from the same parts in a man's brain.
2. Describe the two coverings of the brain.

3. Describe the medulla, its nerves and reflex action; its respiratory center; its vasomotor center; and the effects of its injury.
4. Describe the cerebellum and give its action.
5. Describe the optic tubercles and give their action.
6. Describe the cerebrum; its hemispheres, fissures, convolutions, gray and white matter, and regions.
7. Locate the region in which impressions of sight are received; of touch; of hearing; of smell; and of taste.
8. Describe the region from which motor impulses for voluntary motion are sent out.
9. Describe the memory, and show why recalling one thought brings to mind another thought of the same object.
10. Locate the thought region of the brain, and describe the process of thought.
11. Show that by speech man gains ideas which an animal can get only by actual experience.
12. Locate and describe the mode of action of the center for spoken words; for written speech; and of the speech-hearing and speech-seeing centers.
13. Describe the three main divisions of the acts of the mind.
14. Compare the corresponding parts of the brains of different animals with each other and with the same parts of the brain of man.
15. Describe the nervous system in insects, worms, shellfish, and in the lowest forms of animals.

CALIFORNIA COLLEGE of PHARMACY

CHAPTER XXXII

INFLUENCES WHICH AFFECT THE MIND

550. Stimulation to action. — The thought cells of the brain are given power over voluntary actions of the body, with no higher power to cause them to act, except the will, which is the result of their own action. Were a child left entirely to itself, it would probably exercise its mind no more than an animal. But the sight of objects and ambitions not yet attained spurs the thought cells to action, just as sensations cause the spinal cord and motor region to act. Without constant stimulus of the senses and feelings the thought cells languish and almost cease to act. As the body is compelled to grow by the cells of the spinal cord, so must the mind be compelled to grow by an effort of the will. Few men possess a will strong enough to act without the stimulus of other minds, but association with trained minds arouses the will to exercise one's own mind.

551. Concentration of the mind. — In order to become educated, the mind must be exercised persistently and for hours at a time. The mind does not grow unless its whole energies are often directed towards a single object. It is not study to read a page and then to converse about sports for a moment and then to study another moment, for each impression sweeps away the preceding one. True study is to sit down in a quiet room, and to fix the mind upon the book continuously for an hour or more. Then the mind will be occupied so that it takes no note of time or outside

impressions. Any one will find study interesting if he will concentrate his mind upon a subject so that he gains knowledge. Then when playtime comes he will enter into the sport with zest and satisfaction. No one who has not been working can truly enjoy play.

552. Persistence of mental impressions. — Brain work requires heat and energy like muscular work. The cells of the cerebrum retain an impression of each thought, which is deep and permanent in proportion to the power expended upon it. A lesson learned in a minute makes some impression upon the cells, but it is gone in another moment. A dull boy hammers away at a lesson by the hour, but at the end of a year he will have retained far more than the brilliant boy who loses his impressions as fast as he gains them.

It is extremely difficult to efface impressions once really made upon the cerebral cells. Apparently, knowledge may be forgotten, but some day something will cause the cells to recall the impressions. Thus it is very important to avoid all thoughts which we should be ashamed to recall.

553. Habit. — Memories of thoughts often repeated may arise in spite of the will to restrain them, and may compel the motor region to do acts which the will utterly abhors. At first a man's will has to direct the thoughts to speak profane words. Soon the words become so imprinted in thought that they arise even without his knowledge. Habits grow faster and stronger than the will to overcome them. On the other hand, one can form a habit of study and of mind cultivation so that mental work is a pleasure. The more one works with his mind, the more he enjoys his work. The mind is constantly forming habits of thought. Even if it thinks nothing bad, yet it may soon acquire a lazy habit of not thinking at all.

554. Heredity. — Impressions of any kind may become so permanent that one's children have a tendency to

acquire them. The son of a criminal has a natural tendency to become a criminal, and even if he is well brought up in an upright family he will be far more likely to yield to temptation than a well-born child. Children of educated parents take naturally to study. Children of excitable and nervous parents will also inherit their disposition. By education, natural tendencies of mind and character can be overcome. If a wrong tendency is known and is not corrected, the blame for future action of the child will lie with his educators rather than with the man.

555. Unconscious mind action. — When the mind is intensely occupied it may not take note of severe sensory impressions. Thus soldiers in battle often fight on, unconscious of severe wounds. You may try in vain to recall a name. Later, when you are thinking of something else, the name may flash into your mind. You may strive to direct the mind to a lesson, but thoughts of a sick friend may persist in arising, and may shut out all thoughts connected with the study. In acquiring any new thought the mind must reason by conscious efforts, step by step, until the idea is clearly in view. Ever afterward the mind may reason out the steps unconsciously and almost instantly, so that we may lose sight of the complexity of the mental processes involved in forming the idea. Learning to perform any mental process is essentially becoming able to do it with little or no conscious effort. Then the mind, relieved of the conscious direction of thoughts already learned, is free to acquire new ones. Man is probably unconscious of most of the steps in his mental processes.

556. Sleep. — It is as impossible for the mind to put forth conscious effort continually as it is for the muscles. A rest from conscious effort is called *sleep*. As a rule, a man needs about seven or eight hours of good sleep; a boy of sixteen needs nine or ten hours, while one of six needs twelve. Sleep should be regular, so that the brain may not become excessively tired between times. As a general rule, an early hour both for going to bed and

for rising is desirable. If a student would go to bed when he feels sleepy, and would sleep an hour or two longer each night, he would feel able to do more and better work during his working hours.

557. Sleeplessness. — Like other organs while resting, the brain contains but a small quantity of blood during sleep. If a large amount of blood continues to flow through it, sleep will be impossible. Often when a person cannot sleep he can feel the pulse in his temples throb and hear it as his head lies upon the pillow.

A common cause of sleeplessness is an empty stomach. A light lunch will often cause the arteries of the abdomen to dilate and take up the blood which circulates in the brain and so relieve the cause of sleeplessness.

Lack of work during the day may be a cause of sleeplessness. Many a man finds himself suddenly unable to sleep when he retires from active business. It seems to be a law of nature that he who does not work cannot sleep, for he is not tired enough to need a rest. Occupation for the mind and body will give such persons a good night's sleep.

Worry will also cause sleeplessness, for it keeps the cells of the brain in action just sufficiently to attract the blood to the head. The brain can endure extremely hard work if it only gets rest between times.

Narcotics, like opium and chloral, will always produce sleep if taken in sufficient doses. But they injure the cells to a greater degree than they do good. In times of anxiety the temptation to resort to them is great, but their use at such times invariably leads to a habit of using them, with all its accompanying evils and dangers.

558. Dreams. — Sometimes during sleep the sensory and motor regions recall their memories with the vividness of real life. This is a *dream*. The thought regions rarely take part in a dream. Disordered memories of the sensory and motor regions seem to be realities, but in the absence of judgment they seem harmonious and natural, and we recognize their fantastic nature only when reason returns with the waking hours. Formerly dreams were supposed to be heralds of events to come; but now it is known that they are but the shadows of previous experiences.

559. Change of occupation. — When one set of brain cells has become tired, it is well to direct the thoughts to another subject and let the first set of cells rest. It is a relief to study a history lesson after working hard at arithmetic problems. A change of occupation is the best kind of rest. It is well to alternate pure brain work with work which, like gardening and carpentering, requires muscular effort.

560. Healthy bodies. — The brain depends upon the blood and digestive organs for the power with which to work. When any of the organs are acting improperly the brain is the first to suffer. The strongest brains are contained in the healthiest bodies. No kind of food is brain food more than another, but fish and phosphates are hardly so valuable as beefsteak and salt.

561. Exercise and brain work. — Muscular exercise is needed to keep the body in the best physical condition. Thus it makes the brain stronger. It also takes some blood which otherwise would continue to circulate in the brain, and thus it rests the mind after work.

If exercise is continued until the body is tired, no energy is left for the brain, but sleep comes on as soon as the body composes itself for brain work. Exercise for the benefit of the brain should be brisk in order to produce the best effect upon the circulation of the blood, but it should never be carried to the point of fatigue.

562. Nervousness. — When the brain is exhausted from overwork or from worry, it has not enough energy to control itself or the reflex actions of the spinal cord. Slight and strong sensations are equally unpleasant, and the effort to control the feelings seems to increase the suffering. Thus there arises a condition called *nervousness*.

Nervousness is a lack of self-control. The judicious expression of sympathy by a strong-willed person is the best means of overcoming it. On the other hand, sarcasm and scolding only do injury and increase the nervousness.

563. Hysteria. — An extreme lack of self-control is called

hysteria. The person laughs or cries at trivial things. The motor and sensory regions often seem paralyzed. Persons may even wound themselves to inspire sympathy. Yet there may be most violent convulsive movements. A well-marked case closely resembles the actions of a spoiled child when his will is crossed.

The treatment of hysteria is to arouse the will power. Expressions of sympathy only make the condition far worse. A firm and stern nurse can usually command obedience. Any sudden fright will generally break up an attack.

564. Insanity. — A persistent lack of control of the brain in one or more directions is called *insanity*. Nervousness often repeated and yielded to may become insanity. Worry and overwork are extremely common causes, while alcohol causes half the cases in asylums. Often the weakness of the brain cells is inherited.

A person about to become insane is changed in disposition and character. There is a lack of self-control and of judgment. Prompt rest and care of the body may overcome the attack, but a strong-willed friend will be needed to guide the treatment, for the patient thinks that everybody except himself is wrong.

565. Forms of insanity. — In insanity there are no new mental traits or possessions by demons, as used to be supposed, but only an increase of some mental acts and a decrease of others. The expression *an unbalanced mind* well describes the condition. There are three main forms of its disturbance, giving rise to three forms of insanity.

An increase or hastening of one or all mental acts sometimes takes place. The thoughts flow faster than words can express them, and so the talk is a meaningless gibberish. The senses are uncommonly alert, and one may think he hears and sees things which do not exist. He cannot understand why others are so slow and dull, and so is apt to show violent outbursts of temper. Yet although he may harm others,

he will seldom hurt himself intentionally. This condition is called *mania*, and constitutes the popular idea of a crazy person.

In a second form of insanity the thoughts flow slowly. Questions are answered in a hesitating way of which the person is conscious, so that he feels that he is incapable of doing business or even associating with men. He becomes gloomy, and imagines he has committed an unpardonable sin which he endeavors to discover. He reads his Bible, but imagines that all its curses apply to him personally. He finally tries to destroy himself so that he may no longer be a burden to his friends. This condition is called *melancholia*.

A weakening of the whole brain is the third form of insanity. Degeneration of the brain cells often occurs in old people, and is commonly called *softening of the brain*. It may occur in middle age. Alcoholic drink is a common cause of the condition.

566. Treatment of insanity. — Insane persons can usually talk and exercise some reasoning powers. A sympathetic nurse should win their confidence and control them by reason and persuasion. Special training is required to carry out proper treatment, and so it is usually best to remove them to an asylum. Most cases of insanity improve in from three to six months, and many permanently recover.

567. Delirium of fever. — In poisoning, either by drugs or by the poisons of sickness, the mind is apt to be somewhat disturbed. Anything which diminishes the fever will quiet the mental disturbance, and with the end of the fever the mind regains its right state. In rare cases, the delirium persists, and is then a real insanity.

568. Injuries to the brain. — The effects of a blow or other injury to the brain depend upon its situation. Any injury may cause unconsciousness. Injuries to the top of the brain impair the faculties situated in the injured regions, but seldom cause death. Injuries to the base of the brain are usually fatal by involving the medulla. After the effects of the blow have passed off, a blood clot remaining may still cause paralysis of the cells of a particular part so that the person may lose certain mental powers.

569. Apoplexy. — The arteries of old persons sometimes become hard and brittle so that one is liable to burst in the

brain, especially in its motor region. Then the pressure of the escaped blood injures or destroys some of the brain cells. This constitutes *apoplexy*, or a stroke of paralysis. There is usually unconsciousness for a time, followed by paralysis of some limb and of speech. Recovery is usually slow and imperfect. If the medulla is affected, death quickly results. Confusion of speech, dizziness, and tingling in a limb usually precede an attack for some days. When a person is taken with a stroke of apoplexy, he should be kept very quiet, with his head raised, so that the blood will flow through the brain as gently as possible.

570. Fits. — If the cells of the motor region of the brain are irritated, as by a sliver of bone or a blood clot, they may send impulses at intervals to produce violent movements of the muscles. This is called a *convulsion* or a *fit*. An operation for the removal of the substance which presses upon the cells will relieve the fits.

In young children, irritation of indigestible food in the intestine or of the poisons of fevers may cause the spinal cord or motor region to send out reflex orders and so produce a convulsion or fit. Convulsions in a child can be stopped by immersing it in a tub of very warm water. Then something to clear out its intestine should be given so as to remove the cause of the convulsions. In all forms of convulsions there is little suffering, for the person is wholly unconscious.

Convulsions may come without warning and produce entire unconsciousness for a minute or two, when they cease, and the person is apparently none the worse for it. This trouble is called *epilepsy* or *fits*.

During the fit there is no danger except that a person may bite his tongue. So the only thing to be done is to stuff a handkerchief into his mouth so as to crowd the tongue away from the teeth. Excitement is liable to bring on fits in a person subject to them.

571. Panics. — In times of bodily or financial danger, where many are assembled, a single person may infect the whole audience with an insane fear. Then each person thinks only of his own safety, and many are sure to be trampled upon and injured. In such a time a single cool head will do much to calm the excitement. Fire drills in school teach the pupils to be orderly in the face of danger.

SUMMARY

1. Constant effort of the will is needed to keep the thought cells of the brain acting.
2. A few repetitions of either good or bad acts produce *habits* of doing them.
3. Many mental acts are done without consciousness.
4. In sleep the thought cells rest from work and there is complete unconsciousness. Lack of mental occupation during the day, worry, and an empty stomach are common causes of sleeplessness.
5. A change of occupation is rest for the mind.
6. Active exercise, short of fatigue, improves the mind as well as the body.
7. A lack of self-control when irritated by slight sensations is *nervousness*. An extreme lack of will power is *hysteria*.
8. A persistent lack of control of the thoughts is *insanity*. The thoughts may either be hastened, or hindered, or suppressed, giving rise to three forms of the trouble.
9. In fevers there is often a temporary delirium which resembles insanity.
10. In old people, an artery of the brain sometimes bursts, and the clot, pressing upon the nerve cells, stops their action and produces a shock of apoplexy.
11. Irritation of the motor region may cause the cells to send orders for violent muscular movements, producing a fit or convulsion.

REVIEW TOPICS

- I. State how the cells of the cerebrum differ from the other cells of the body in regard to being controlled and made to act.

2. Tell how best to study.
3. Discuss persistence of impressions ; habit ; heredity.
4. Show how the mind acts without our knowledge.
5. Tell the nature of sleep ; its use ; how much is required ; and when to sleep.
6. Tell how sleeplessness is produced by an empty stomach ; by worry ; and by lack of work.
7. Tell the nature of dreams and of what ideas they usually consist.
8. Show how a change of occupation rests the brain.
9. Show that good health is needed for good brain work, and tell how exercise affects the brain.
10. Show the nature of nervousness, and of hysteria, and tell how to overcome them.
11. Give the causes of insanity, its three forms, and its treatment.
12. Give the result of blows upon the brain.
13. Give the nature of a stroke of apoplexy, and show how it produces paralysis.
14. Discuss fits ; their causes, forms, and treatment.
15. Discuss panics.

CHAPTER XXXIII

EFFECTS OF NARCOTICS UPON THE MIND

572. Stages of action. — A perfect engine acts smoothly, and with an ease of motion which suggests a delight in its work. The body is an engine at the service of the will. A derangement of any part disturbs the action of the brain according to the extent of the disorder. While little or no alcohol can ever be found in the brain, yet the leucomaines and other poisons produced by the action of alcohol reach the whole body, and produce a profound effect upon the brain sooner than upon any other part. Three stages of the effects of alcohol are well marked:—

First, there is a stage of *stimulation*; second, the cells act in an uncertain manner. This is the stage of *disturbed* action; third, the cells act slowly or even cease to act. This is the stage of *paralysis*. All three stages are often seen in drunken men upon the streets.

573. Stage of stimulation. — A small amount of alcohol causes the blood to circulate more rapidly. More food reaches the brain cells, and so they show more activity. It produces a happy state of mind in which men overestimate their abilities. Men drink mainly for this effect of the alcohol.

Some gifted men with weak wills exert themselves only when under the influence of strong drink, and from this fact many reason that alcohol increases the brain power. These gifted men hang about the saloons, eating little and drinking much. In this condition their brains receive no strength or energy to devote to any object. A drink fur-

nishes a quick stimulation which at once excites the brain to great activity. Thus it is enabled to do brilliant work while the effects of the alcohol last. In half an hour the poisonous effects assert themselves, and the man's condition is worse than ever. Good food and a regular life would give such a man a continuous store of energy with which he could perform brilliant work day after day. Alcohol is such a poor substitute for the food that it enables him to work only for a few moments at a time.

574. Stage of disturbed action.—The stimulation of a drink of alcohol is uncertain, and, at best, lasts only for a few minutes. Alcohol uses oxygen which would otherwise be available for the brain cells as well as for the other cells of the body. An ounce and a half of alcohol a day will begin to interfere with oxidation and to disturb the brain, and far less will do so if it all is taken at once.

575. Moral effect.—Alcohol weakens and disturbs the action of the brain cells, beginning with those most highly developed. These are thoughts of our relation to other men. So a person beginning to be under the influence of drink will be selfish and inconsiderate of others. He will insult his friends and get angry without cause.

576. Effect upon his judgment.—The judgment or reasoning concerning the effect of one's acts upon himself is the next to be disturbed. He becomes daring and careless. He proposes impossible plans in business. If he has a tendency to commit a crime, he will do it now. Many a thief or murderer has gotten himself into this state of drunkenness to enable him to commit his crime recklessly. If a man has a tendency to swear or to be unkind, he will show it, for the restraint of judgment is gone. The blunted judgment takes no note of coming danger or of business failure. Many a man drinks to drown trouble.

577. Effect upon the motor regions. — Shortly after the judgment is clouded the motor regions begin to fail. Then the hand will be unsteady, and the legs will totter as they support the body. The person is now visibly drunk, and his judgment is so far gone that he could not decide where to go even if his legs could carry him. The cerebellum is also affected, so that he is still more uncertain in his movements.

578. Effect upon the sensory regions. — Next after the motor regions, the sensory regions begin to fail. Sensations of touch are first affected, so that the drinker cannot feel the glass at his lips. In former days it used to be the custom to make a person drunk and insensitive before he underwent a surgical operation. After the sensations of touch are benumbed the sight begins to fail. A drunken man sees double, or the buildings and trees seem to sway and dance before his eyes. Hearing, smell, and taste are also lessened, so that he does not heed loathsome surroundings, but will lie contented in a filthy gutter.

579. Stage of paralysis. — When the thought, motor, and sensory regions of a man's brain are all weakened or stopped in their action, the mind is dull and drowsy, and soon he is in a condition resembling a deep sleep, from which he can be roused only with difficulty. The medulla and spinal cord still carry on the processes of life, but they too begin to be overpowered. By the time the cerebrum is almost overcome, the spinal cord is also much decreased in action so that there is no response to pricks or blows. Then the medulla is all that remains of the central nervous system. It continues to send out impulses for respiration. The respiration and circulation are the only remaining signs of life, but even they are weak, and may become almost imperceptible. Since little oxy-

gen enters the body, little heat is produced. If the night is at all cold, the drunken man is in great danger of freezing to death. It is only a step to the total cessation of the action of the medulla and failure of respiration.

In cities men often are found in the streets in the last stage of drunkenness. They closely resemble cases in which the action of the brain is destroyed by a severe blow upon the head which leaves no external mark.

580. Effects of long-continued drinking. — Either heavy or moderate drinking may cause in the brain and mind a slow change which resembles an excessively slowly developed drunken state. As in drunkenness, the first change is a disregard for the comfort of others. Then the thoughts wander, and the mind cannot grasp a situation as it once could. Later the motor region is affected so that the hand trembles and the gait is unsteady. All these changes are like those which naturally occur in old persons. Drink makes a person old too soon. In many drinkers the judgment entirely disappears, and the drinker is insane. He is in a continual state resembling drunkenness. Alcohol produces more insanity than all other causes combined.

581. Effects of bad company. — The low companionship which a drunkard keeps, itself tends to dwarf the mind and to make one careless in morals and judgment. Men also lead each other into temptation. If a man were alone, one drink might satisfy him, but meeting others, he lingers to talk, and so drinks again to keep company with the rest.

582. Delirium tremens. — After a prolonged drunken state, or after severe injury, a heavy drinker is liable to violent disturbance of the mind, called *delirium tremens*. In it his sensory regions form exaggerated memories of fantastic and hideous views, in which demons and foul reptiles seem present on purpose to torment him. In his fear he will cry out and will use violence in his endeavors to escape. The trouble may last continually for several days, and may permit the sufferer to take neither food nor sleep.

583. Alcoholic inheritance. — The weak body and mind of a confirmed drunkard are almost surely transmitted to his children, but any one who drinks at all may transmit some undesirable traits. The appetite for liquor also may be transmitted to the children. If they are kept from temptation, they will lead temperate lives, but they will be very apt to yield to the desire for drink if the temptation is thrown in their way.

584. Treatment of the alcoholic habit. — By a few repetitions of drink the memory of its sensations becomes so strong that it overrules the thoughts and will, and compels its own gratification in more drink. At first, a man can resist the appeals of his appetite, but after the cells of the sensory region have gained gratification a few times, they, instead of the will, direct the motor region to secure the drink. Many a drunkard can no more control his appetite than he can control the memory of the drink. What was once a pleasant memory of the subordinate sensory region, becomes the giant demon, enslaving the kingly thought regions.

A drinker should not be laughed at or scorned, but he should be encouraged to use his will in overcoming the desire for drink. To this end everything ennobling should be placed in his way. Good books, good companionship, and, above all, the encouragement of sincerely Christian people are almost absolute necessities in his reformation.

Drugs have almost no effect upon the habit, for they cannot abolish memory nor increase the will power. Total abstinence, not only from the drink, but also from buildings where it is sold and from the association of those who have been drinkers, is necessary for a cure.

585. Tobacco. — By smoking, a greater amount of blood is drawn into the head, and the increased flow of blood seems to make the brain more active. Sucking air through a small quill produces the same effect upon the brain as

sucking smoke through a pipe. In fact, smokers often cannot tell by the taste alone, whether the pipe or cigar is alight or not; but they unconsciously judge mainly by seeing the smoke. Since tobacco weakens the heart, less blood will flow through the body when tobacco in any form is used, and this fact will tend to make the mind act less strongly than before. The nicotine is also a direct nerve poison.

586. Drug habits. — Opium, cocaine, and other narcotic drugs whose use may become a habit, affect the mind in the same way as alcohol. Every one who habitually uses any of these drugs will surely become a mental as well as a physical wreck. Opium, especially, seems to have a fiendish effect in destroying the morality of its users. They begin by lying and cheating in order to obtain the drug without the knowledge of their friends, and they finally end by becoming dishonest in all things. But the drug produces a weak mind and body which soon end in death. Most of these drugs are far more dangerous than tobacco or alcohol.

587. Ether and chloroform anæsthesia. — Ether and chloroform are both substances manufactured from alcohol. When they are breathed into the lungs they produce effects which resemble a rapid state of drunkenness carried to its last stage. For a brief time, the brain is excited and then its faculties disappear one after another. In from five to fifteen minutes the brain and spinal cord are completely overcome, and only the medulla continues in action to carry on respiration and the circulation of blood. A person may be safely kept in this condition for two or three hours. Upon stopping the inhalation the effects pass off in reverse order, until in from ten minutes to an hour one has the full use of his brain again. The thought regions are overcome long before the motor regions, and so a person taking ether may struggle and cry out in apparent agony long after he has become completely unconscious. The struggling is reflex and takes place while a person is insensible to suffering.

SUMMARY

1. Because a small quantity of alcohol stimulates the heart and increases the flow of blood in the brain, it stimulates the mind to greater action. This lasts for a short time only.
2. A little more alcohol is a narcotic to the brain cells and weakens them so that they act in an uncertain manner.
3. The first action to be disturbed is one's thoughts of the welfare of others, and the second is the judgment of one's own affairs. At this stage the actions are wild and foolish.
4. Next the motor region is disturbed, and a man is now noticeably drunk.
5. Next his sensory regions are disturbed so that he cannot see and hear and feel so well as he should. He is now dull and sleepy, or dead drunk.
6. Next the medulla is affected so that the respiration and action of the heart are disturbed. Then death is near at hand.
7. Continued drinking slowly overcomes the faculties of the mind in the same order that they are overcome in drunkenness. When the cells are seriously affected, the person is insane.
8. The habit of taking alcohol may become so deeply set in the brain cells that it is a disease overcoming the will.
9. Sucking in tobacco smoke causes more blood to flow to the brain, and so slightly increases its power, but the tobacco itself weakens the brain.
10. Opium, cocaine, and all other drugs, when habitually used, always weaken and destroy the mind.

REVIEW TOPICS

1. Tell why alcohol affects the brain and give the three stages of its effects.
2. Describe the stage of stimulation.
3. Trace the career of a man as he becomes more and more under the influence of drink, giving the effects of alcohol upon the moral feelings; upon the judgment; upon the motor region and cerebellum; upon the sensory region; and upon the medulla.
4. Describe the permanent effects which long-continued drinking produces in the brain.
5. Show how the bad company kept by drinkers affects their minds.
6. Describe delirium tremens.
7. Show that the taste for alcohol and the effects of its use may be transmitted to children.
8. Show that the alcohol habit is a disease, and give its treatment.
9. Tell how tobacco affects the brain.
10. Tell how drug habits, as opium using, affect the brain.
11. Tell how ether and chloroform produce insensibility, and how the state resembles drunkenness.

CHAPTER XXXIV

TASTE, SMELL, AND HEARING

588. Touch. — Touch is a special sense. Its sensations are aroused without the need of any special organ. So the discussion of sensory nerves is really a discussion of the special sense of touch. (See p. 269.)

589. Taste. — Taste is a special sense which is located in the tongue, palate, and pharynx. All these parts are endowed with a delicate sense of touch, but in addition two pairs of cranial nerves carry special sensations of taste. The impulses are aroused by the direct action of substances upon the nerves. The motions of chewing and a good flow of saliva aid the sense of taste by bringing food in contact with the nerves, while a dry substance, or one which will not dissolve in water, can have no taste. All tastes are some combination of sweet, sour, bitter, and salt tastes. Sweetness and sourness are recognized mainly by the front part of the tongue, and bitterness and saltiness by the back parts and pharynx.

Taste is greatly influenced by the sense of smell. The real taste of coffee is greatly changed by the odor which reaches the back part of the nose as it is swallowed.

590. Use of taste. — Taste enables a man to detect spoiled or unwholesome food. The sense is capable of great education. The prices of different grades of tea are determined by expert tea tasters, who devote their whole time to tasting different samples. Alcohol and tobacco

irritate the nerves in the mouth and so blunt the taste for good food. For this reason a drinker does not enjoy plain food, but requires spices to excite his taste.

591. The nose. — Impressions of smell originate within the nose. Each nostril leads to a wedge-shaped cavity,

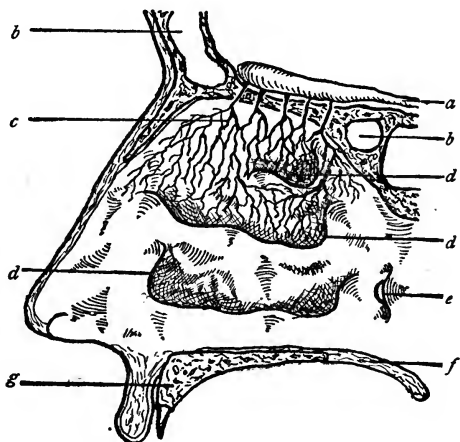

The outer wall of the nose.

a the nerve of smell at the base of the brain.

b air spaces in the skull bones.

c branches of the nerve of smell.

d curved curtains of bone.

e opening of the Eustachian tube.

f soft palate.

g upper jawbone.

which opens into the pharynx. The inner wall of each cavity is smooth, and is formed by the thin bone that separates the two nostrils. Each outer wall is formed by three very thin bones which hang down like narrow curtains. They nearly cover cavities, called *sinuses*, which are situated in the neighboring bones. One sinus occupies the interior of the upper jawbone, and is called the *antrum*. The part of the skull behind the eyebrows is honeycombed with small cavities, called the *frontal sinuses*.

592. Olfactory nerves. — From the under surface of the brain, about twenty nerves extend through perforations in the upper part of the nose and spread out over the upper one third of the surface of the nasal cavities. An odorous gas entering the nose comes in contact with the ends of these nerves and excites the sense of smell. An odor is found only in substances which can be turned to a vapor.

The olfactory nerves are so delicate that they can perceive the presence of gases which cannot be detected in any other way. Some substances excite the sense of smell when they are in such small quantities that they are given off for years without causing a perceptible lessening of the weight of the substance.

When too much mucus covers the nerve endings, or when the surface of epithelium is dry, no gas can reach the nerves, and then the sense of smell is diminished. A cold in the head can produce either condition.

593. Use of smell. — Smell is a warning against foul air and decaying matter. The gases themselves are in too small quantities to do harm, yet they are a sign that other substances are present which can harm the body. Air which has no odor is almost surely fit to be breathed. Meat which has a pleasant odor is almost certainly fresh.

Tobacco smoke and snuff are irritating to the delicate nerves of smell, and partly deprive its users of nature's most useful protection against foul air.

594. The inner ear. — Sound is produced by certain air waves which are received by nerves in the ear. There they excite impulses which the brain interprets as sound. In the hard bone, which rises from the bottom of the skull by each ear, is a tortuous cavity, called the *labyrinth* or *internal ear*. The center of the labyrinth is about one eighth of an inch in diameter, and is called the *vestibule*. From the vestibule there extends a small spiral

tunnel, called the *cochlea*, which is like the inside of a snail's shell, and also three other tunnels called the *semicircular canals*, from their shape.

The labyrinth is filled with a clear liquid, and is lined with epithelial cells, among which the nerves of hearing end. Upon the surface of the epithelium are cilia, among which are fine hard particles called the *ear sand*. The air waves produce waves in the liquid which beat against the

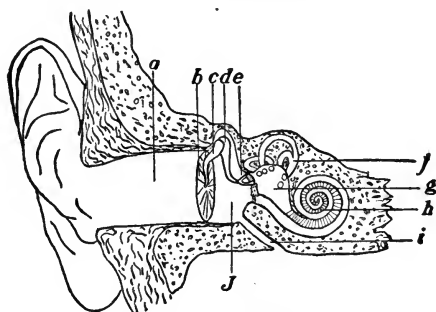

Diagram of the ear.

- | | |
|----------------------------------|----------------------------------|
| <i>a</i> outer air passage. | <i>f</i> semicircular canals. |
| <i>b</i> membrana tympani. | <i>g</i> vestibule of inner ear. |
| <i>c</i> malleus or hammer bone. | <i>h</i> cochlea. |
| <i>d</i> incus or anvil bone. | <i>i</i> Eustachian tube. |
| <i>e</i> stapes or stirrup bone. | <i>j</i> tympanum or middle ear. |

cilia and produce the sense of sound. Waves in the fluid surrounding the nerves must occur at least sixteen times a second in order to produce a sound. When they occur more than thirty-eight thousand times a second, they are too rapid for the nerves to take account of their motion, and so no sound at all will be heard.

The *semicircular canals* do not seem to be essential to hearing, but when they are diseased a person is unable to balance himself so as to walk or even to stand. The movements of the fluid in the canal seem to produce nervous impressions which, in the cerebellum, excite such reflex actions as are necessary to balance the body in an upright position.

595. The middle ear. — To make hearing distinct, a special mechanism is provided for transmitting the air vibrations to the inner ear through two outer cavities.

A small aperture connects the inner ear with a middle cavity called the *middle ear*, or *tympanum*. The middle ear is half an inch long and a quarter of an inch broad. It is lined with mucous membrane and is filled with air. Its outer end is closed like a drum, by a thin leaf called the *drum membrane* or *membrana tympani*, while a similar membrane closes the aperture to the inner ear. The cavity of the middle ear is greatly increased by its extending backward into a bony projection called the *mastoid process*, which can be felt just behind the outer ear. It connects with the pharynx by means of a tube which is about the size of a knitting needle and is called the *Eustachian tube*. The act of swallowing opens the tube.

596. Bones of the middle ear. — The essential part of the middle ear is a chain of small bones called the *malleus*, *incus*, and *stapes*, which extend across its cavity from one membrane to the other.

Air waves, striking the ear drum, throw it into vibrations, which the chain of bones transmits to the inner ear. The tympanum and its extension into the mastoid cells act like the sounding box of a violin to increase the vibrations.

597. Deafness. — The Eustachian tube permits air to pass in and out of the middle ear so as to keep the air pressure within the same as it is outside. When it is closed, the air pressure outside may change, and thus the drum membrane will be pressed upon and prevented from vibrating freely. This results in partial deafness. Enlarged tonsils and adenoid vegetations are liable to cause a stoppage of the tube and to produce deafness, and for this reason they should always be removed. When the tube is stopped, there is a feeling of fullness in the ear, and roaring or singing noises will be heard.

Deafness due to a stoppage of the Eustachian tube is the most common form. It often can be relieved by opening the tube by swallowing. By blowing the nose hard with the nose and mouth closed and at the same time puffing out the cheeks and swallowing, one can almost always force air through the tube into the ear and thus relieve the deafness. This should be done several times a day.

Sometimes an inflammation extends from the pharynx up the Eustachian tube and sets up an inflammation in the middle ear like that in the throat. Mucus and matter then collect in the middle ear and press upon the ear drum, causing a severe earache. If the tube does not open, the membrane may burst and allow the matter to run out of the ear.

598. *A running ear* should be kept clean by cleansing it with warm boiled water as often as the matter collects. Sometimes in running ears, the disease eats away the bones and produces inflammation of the brain. For this reason running ears are always dangerous.

Some drugs may produce a ringing in the ears and partial deafness. Quinine, which is taken for malaria, and salicylic acid, which is taken for rheumatism, may cause it, but the effects pass off within a few hours.

Boxing the ears suddenly compresses air against the drum membrane, producing pain and sometimes even bursting the membrane. Loud reports, as of cannon, cause such extensive and painful vibrations of the membrane that deafness may result.

599. Early in life a child may become deaf, and yet no one may be aware of the trouble. Then the child is apparently inattentive and does not answer when spoken to. At school the teacher may ascribe his lack of attention to carelessness or ill temper. In consequence, the child receives unjust punishment. The hearing of every dull and inattentive child should be examined.

600. The outer ear.—Outside of the drum membrane is a passage to the air about an inch in length and one quarter of an inch in diameter, formed partly of bone and partly of flesh. Around its opening is a shell-shaped fold of flesh which, together with the passage, is called the *outer ear*. Connected with it are rudimentary muscles

which are so well developed in some persons that they can move their ears as a horse does.

601. Ear wax. — The epithelium of the outer half of the passage secretes a kind of bitter and sticky wax which keeps insects and dust from reaching the drum membrane. The epithelium grows outward towards the surface like the nails, and carries the wax with it, thus preventing its accumulation. Often in picking the ears the wax is pushed against the drum membrane so that it cannot vibrate. Next to throat trouble this is the most common cause of deafness. The accumulated wax can be softened and removed by gently syringing with warm water. Wax can best be removed with the loop of the smallest-sized hair pin, taking care not to insert it far enough to touch the drum membrane.

602. Illusions of hearing. — Too dense or too rare air in the middle ear, too much blood circulating in the inner ear, the use of certain drugs, as quinine, blows upon the head or wax in the ear, are all causes which may excite the nerves of hearing. Then the impression goes to the brain as though a real sound had excited the nerves.

The cells of the brain itself may interpret a sensation wrongly ; thus an insane person may think that the sound of his own pulse beating in his ears is the echo of the blows of demons within his head.

Sometimes persons recall memories of sounds so vividly that they seem to be real. This occurs naturally in dreams, but it may occur in an insane person at any time.

603. The ear in lower animals. — In four-footed animals and in birds the ear is the same as in man. In turtles and frogs there is no outer ear, but the drumhead lies just under the skin, forming a visible circle behind the eyes, while the middle ear contains a single bone. In the snake

there is no external or middle ear, although a bone extends from the inner ear to a kind of drum membrane just under the skin. In the fish there is no external or middle ear, and the labyrinth has no cochlea, but the vibrations are transmitted only through the skull. In the lobster there is a small cavity filled with liquid, in which are the endings of the nerves of hearing. The vibrations producing sound are transmitted to the bag through the sides of its head. Thus all animals which have ears at all, possess what in man is the internal ear.

SUMMARY

1. The sense of taste is excited by substances which become dissolved in the saliva and excite special nerves in the tongue and pharynx.
2. The sense of taste enables one to distinguish good food from bad.
3. The sense of smell is excited by minute amounts of gas, which excite special nerves in the upper part of the nose.
4. Smell guards us against foul air and decayed substances.
5. Sound is produced by vibrations of the air.
6. The inner ear consists of winding canals filled with liquid into which special nerves project. Vibrations of the air excite the nerves and produce the sense of sound.
7. The middle ear consists of a bony cavity across which three small bones convey the vibrations of the air to the inner ear.
8. Deafness is often caused by the Eustachian tube being stopped.

9. Inflammation of the throat may extend into the middle ear and produce an earache.
10. Enlarged tonsils and adenoid vegetations are the two principal causes of earache and deafness.
11. Running ears should be kept clean.
12. In all animals having a hearing apparatus, the essential and often the only part is the inner ear.

DEMONSTRATIONS

130. Examine the tongue of one of the pupils. Notice that its surface contains three kinds of projections. There is a V-shaped row of large, flat, and smooth projections upon its back part. There are red pinhead-sized projections scattered over the whole front surface. There are also fine projections like velvet spread over the whole surface. In all these projections the nerves of taste seem to end. Examine also a cat's tongue, and note the stiff hairs upon its surface.

131. Test the power of taste in different parts of the tongue. Place a bit of a sweet or of a sour substance in the back of the mouth, and notice the slight taste, while it is easily tasted in the front part. Now place some salt or bitter substance upon the front of the tongue. Notice that it has little taste until it spreads to the back part.

132. Saw lengthwise through a calf's head so as to open the nose. Notice the smooth inner surfaces of the nostrils, and their furrowed outer surfaces produced by the folded bones. Notice that the nostrils open into the pharynx. (See demonstration 35.)

133. Have a butcher remove the bone containing the middle and internal ear from a calf's skull. Carefully cut away the shell of bone over the middle ear. One can judge of its position by measuring down the outer air passage. Notice the size and shape of the middle ear. Notice the ear drum, and the three little bones which stretch from it entirely across the cavity. Notice also that the last bone fits into the small opening leading into the inner ear.

134. The inner ear will be more difficult to show, for it is small and complicated, and is situated deep in a very hard bone. Cut away the bone a little farther in, when the cochlea may be opened, and possibly a semicircular canal will be recognized. The spiral tube of the cochlea is barely $\frac{1}{8}$ of an inch in diameter, while the semicircular canals are as small as a sewing needle, but yet form loops about $\frac{3}{8}$ of an inch across.

REVIEW TOPICS

1. Describe the process of tasting, and tell how smell influences the sense of taste.
2. Give the use of the sense of taste.
3. Describe the endings of the nerves of smell in the nose, and tell how the sensation of smell is produced.
4. Give the use of the sense of smell.
5. Describe the inner ear: its cochlea, semicircular canals, and nerves of hearing, and tell how they act.
6. Describe the middle ear: its bones, the two membranes which close it, and its Eustachian tube.
7. Show how a stoppage of the Eustachian tube may lead to deafness; to running ears.
8. Show how throat trouble may cause ear disease.
9. Tell how to care for running ears.
10. Show why boxing the ears is dangerous.
11. Describe the outer ear: its air passage and wax.
12. Show how the ears may seem to hear sounds which do not exist.
13. Describe the ear in a frog; in a snake; in a fish; in a lobster.

CHAPTER XXXV

THE EYE

604. Light. — Straight lines of light called *rays* pass off from objects in all directions. Each ray is supposed to be a vibrating line in a thin substance called ether, which fills all space.

The vibrations of ether take place many millions of times each second. In sound the air vibrates only a few hundred times. Light travels nearly 185,000 miles each second, while sound travels about 1000 feet in the same time. Light waves are from $\frac{1}{100000}$ to $\frac{1}{10000}$ inch in length, but each sound wave reaches several feet. The length of a wave of light determines its color. Red waves are about twice as long as violet waves. A mixture of all colors produces white light, while black is due to the absence of light. Colors which, like red and green, form white light, are called *complementary* colors.

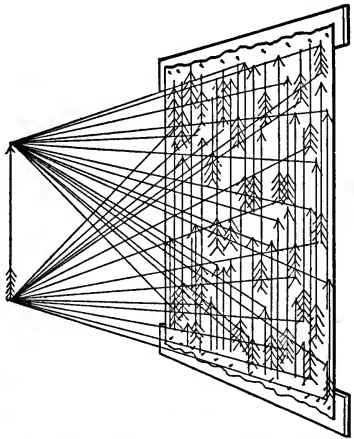

Diagram of light passing from an object.

It passes in every direction, and, falling upon a screen, produces a confused multitude of images, which form only a mass of light, but no one clear image.

In passing through glass or other clear substances, rays of light may be bent from their courses. By a properly shaped glass called a *lens*, rays may be spread apart or may be brought together in a point called

a *focus*. If the focus falls upon a screen, an image of the object giving the light will appear. By changing the kind and the position of the lens the image may be made either larger or smaller than the real object.

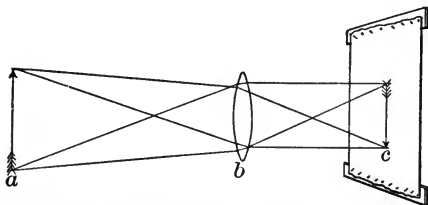

Diagram of the formation of an image with a lens.

- a an object sending off light.
- b a lens which brings all the rays from any point in the object together again into a single point.
- c image of the object a.

Light has the power to produce a chemical change in substances. Photography and bleaching clothes are examples of the action of light. In photography a prepared plate is inclosed in a tight black box, into which light from an object is admitted through a small lens.

The lens brings the light to a focus and forms an image upon the plate.

605. The eye. — The eye is an apparatus like a photographer's camera, but is more perfect. It consists of a round, hollow shell about $\frac{3}{4}$ of an inch in diameter, formed of a very tough membrane about $\frac{1}{16}$ of an inch in thickness, called the *sclerotic coat*. The sclerotic coat is lined with a thin black membrane called the *choroid coat*, which carries the blood tubes, and is colored black so as to prevent reflection of the rays of light. Inside of the choroid coat is a very thin and transparent membrane called the *retina*. The cavity of the eyeball is filled in front with a thin, clear liquid called the *aqueous humor*, while its back part contains a thick, jellylike fluid called the *vitreous humor*. The two humors keep the eyeball distended and in shape.

The nerve of sight, called the *optic nerve*, enters the back part of the eye and separates into fine threads which end in microscopic rods set closely together on their ends

in the retina. The retina corresponds to the photographic plate of a camera. A bulging transparent tissue, called the *cornea*, forms a round window through the front part of the eyeball, and admits light to the retina. Behind the cornea is hung a curtain called the *iris*, in whose center is a hole called the *pupil*. The iris is colored to a shade

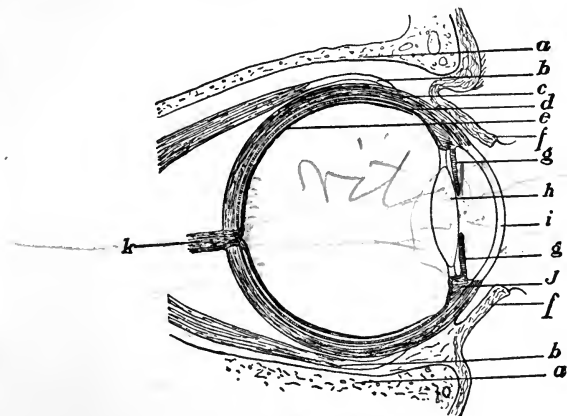

The human eye.

- | | | |
|--|------------------|--|
| <i>a</i> bone of the orbit. | <i>e</i> retina. | <i>i</i> cornea. |
| <i>b</i> muscle which moves the eyeball. | <i>f</i> eyelid. | <i>j</i> muscle which changes the shape of the lens. |
| <i>c</i> sclerotic coat. | <i>g</i> iris. | |
| <i>d</i> choroid coat. | <i>h</i> lens. | <i>k</i> optic nerve. |

varying from blue to dark brown, and it is this which gives the color to the eye.

The iris is composed of muscle fibers which can contract so as to make the pupil smaller. A strong light acts in a reflex way to cause the iris to contract and make the opening of the pupil smaller, but in a dim light the pupil is large, so as to admit all the light possible. Thus the iris regulates the amount of light admitted to the retina.

606. Sight. — Behind the pupil is a lens whose shape can be changed at will by the action of muscles. The

lens brings the light to a focus so as to form an image of an object upon the retina. In the cells of the retina are particles of brown coloring matter in which light produces an instant change. This excites in the optic nerve an impulse which the brain interprets as sight.

607. Coverings of the eye. — The eyeball is loosely situated in a deep depression of the skull, called the *orbit*. The space between it and the bone is padded with fat and crossed by numerous muscles, nerves, and blood tubes. Thus it is thoroughly protected from injury. It can be freely turned at will in all directions by six slender muscles which rise from the back part of the orbit. It is protected in front by two thin but strong lids, which can be moved up and down at will. From the edges of the lids there project two or three rows of stiff curved hairs, which still further protect the eye. The lids can be closed by a flat circular muscle which completely surrounds them. The insides of the lids and the front side of the eyeball, except the cornea, are covered with a soft mucous membrane, called the *conjunctiva*.

608. Tears. — The conjunctiva and cornea are moistened by a saltish fluid called *tears*. Tears are secreted by a gland called the *lachrymal* gland, which is situated just above and to the outer side of the eyeball. At the inner end of the edge of each lid is the opening of a small tube which unites with the tube from the other lid and forms a single tube called the *nasal duct*, leading to the nose. Ordinarily the nasal duct drains away the tears as fast as they are formed, and sometimes, as in crying, their salt taste can be noticed in the mouth. Often they are produced so fast that some run over the lids and fall down the face. The uses of tears are to wash away particles of dust which fall upon the eyeball, and to moisten its surface.

609. Field of view. — A person can clearly recognize objects in only a small part of the field of view just in front of the eyes, while the rest seems to be only indistinct shadows. To be distinct, the image must fall upon the part of the retina less than $\frac{1}{8}$ of an inch across, which is situated directly behind the cornea. In reading a book, the eye can distinctly see two or three words at once, but by rapid and unconscious movements of the eyes sidewise, we cover a larger field of view.

610. Duration of sensations. — The sensation of sight is produced almost instantly when the eyes are directed towards an object, but the image persists for $\frac{1}{10}$ of a second. If a succession of pictures of a moving object are thrown upon a screen at that rate, the object will seem to go through its motions without interruption. Birds flying and waves dashing upon the beach may be thus shown absolutely true to life. A point of light swung about a circle seems to be a shining ring. If two colors are revolved at that rate, the eye no longer sees either one, but a mixture of the two. Thus a blue and a yellow spot side by side, when revolved before the eye, seem a single green spot.

611. Color blindness. — Sometimes the nerves of the retina are unable to recognize certain colors. In the most usual form of color blindness red is supposed to be green or gray. In locomotive engineers and sailors color blindness may be a serious defect, for they are guided by different colored signals, especially those containing red.

612. Exhaustion of the retina. — When the eyes look steadily at objects for a long time the vision becomes blurred. If one gazes steadily at a bright colored object, the retina is fatigued by that color. A white object looked

at now will show a colored spot shaped like the first object, for a part of the retina is no longer able to recognize all the colors which make white light. Its color will always be complementary to the color of the object first looked at. Thus when a red object is used first, a green image appears. The eye is really made color blind for a brief period.

Ordinary lamps and gas jets give a yellowish light, while the sunlight is white. So by lamp light, the colors of objects seem to be changed. In incandescent electric lamps the light is given off from a white-hot filament. Owing to its steadiness, its color and the absence of heat and foul gases, it is the most agreeable light in common use.

613. Care of the eyes. — No light should be strong enough to dazzle the eyes. When, as in public halls, bright lights are in front of the eyes, there is a natural tendency to gaze directly at them, thereby tiring the retina. It would be better to look at the darkest objects in the room.

It is best to have the light come from behind the eye. In working with a lamp in front of the eyes, a shade should cover either the light or the eyes. When the sun shines brightly upon the snow the excess of light exhausts the retina. Then the eyes become painful, and blindness may result.

614. Contraction of the pupil. — A strong light excites the reflex center in the optic tubercles to send out an order for the contraction of the muscles of the iris so as to make the pupil smaller. On the other hand, in the dark the pupil is large, so as to admit all the light possible. When a light is very strong, the reflex centers send orders to the muscles both of the upper and lower lids, and of the eyebrows to pucker themselves over the eyes, so as to leave only a narrow slit for the entrance of light. In this way the eyes are well protected against too strong lights, but the contracted muscles may become tired and painful.

615. Accommodation. — Rays of light coming from a distant object are less diverging than when coming from one near by; then the lens does not need to bend them so much as in seeing objects near by. Adjusting the lens of the eye to near or far vision is called *accommodation*. When the eye muscles are at perfect rest, the eye is accommodated to see clearly at all distances over twenty feet. So distant vision requires no effort. When one wishes to see an object less than twenty feet away from the eye, the muscles must cause the lens to become more curved. Thus the eye can see clearly up to about five inches from the eye. Vision is best when the object is about ten inches from the eye.

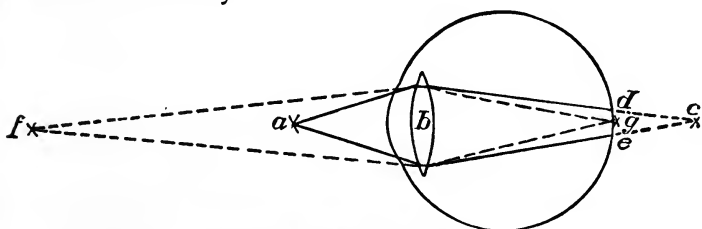

Diagram of the eye in far sight.

The lens *b* does not bring the rays from a point of light *a* together soon enough. So the rays fall over the whole surface of the retina from *d* to *e*, making a confused image instead of a clear point. When the rays spread less apart, as when the light is moved farther away, to *f*, the lens brings them together sooner. Then the rays fall upon a single point of the retina at *g*, and thus form a clear image.

616. Far sight. — At the age of about forty-five, the muscles of the lens lose some of their power of contraction and are unable to make the lens so curved as in youth. Then the eye cannot be adjusted for near vision, while for far vision the sight is as good as ever. So an old man holds his newspaper at arms' length. He also aids the action of his lens by placing before his eye a spectacle lens which corrects the deficiency in the lens of his eye.

617. Near sight. — In young people the lens often brings the rays together too soon. The rays must be made more diverging by

bringing the object very near the eye. Such persons cannot see distinctly at a distance greater than a few inches, but walk about as in a perpetual fog.

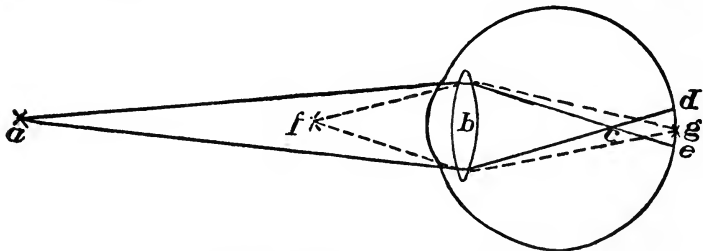

Diagram of the eye in near sight.

The lens b brings the rays from a point of light a together at c too soon. So the rays cross and fall over the whole surface of the retina from d to e , making a confused image instead of a clear point. When the rays are spread apart by bringing the light near the eye, as at f , they come together farther away upon the other side of the lens, as at g . Thus they fall upon a single point of the retina and produce a clear image.

Near sight can be remedied by placing in front of the eye a lens which will make the rays more diverging. So the spectacles have the glasses hollowed out instead of bulging.

618. Astigmatism and headaches. — Sometimes the lens or cornea is more curved in one direction than in another. Then a part of the object will seem distinct, and another part blurred, and the eye muscles will constantly change the focus in the attempt to obtain a full and clear image. This is very tiresome to the eyes, and often causes severe headaches. The remedy is to use a glass which is curved in one direction only, so as to correct only the defective part of the lens.

619. Cataract. — Sometimes the lens becomes hard and white. Then no light can pass through, and there is total blindness. This is called a *cataract*. By a simple and safe operation the lens can be removed, when the light will fall upon the retina as before. Spectacles to take the place of the lens enable the person to see.

620. Judgment of position. — In perfect vision each eye is turned toward the same point, so that the images fall upon corresponding points of the retina. But the two eyes view an object from different positions, and so the images

are not exactly alike. The blending of the images will give the idea of solidity or of position in distinction from the impression that everything is a flat surface. This perception is not natural, but must be learned. Distant objects always seem flat.

621. Movements of the eyes. — If the images of an object do not fall upon corresponding parts of the retinas of the two eyes, two images will be seen. Sometimes a muscle will draw one eye aside so that it does not look in the same direction as the other eye. A person with this defect is said to be cross-eyed.

Young babies have no control of their eye muscles, and so have no distinct vision, except as they catch accidental glimpses. A bright cloth gives them a sensation of color at whatever distance it is held, and so amuses them. At about the age of three months they begin to gain control of their muscles, so that they can focus the eyes and turn them to any object at will. It takes them several months more to acquire a knowledge of solidity and position.

Anything touching the eye causes the lids to close in a reflex manner for protection. Tears flowing over the eye cause the lids to wink and distribute the moisture over the whole surface.

In reading in the cars, the constant jarring of the paper compels the muscles of the eyes to be in constant action to adjust the eye to the ever-varying positions and distances. So they soon become tired and ache. In reading while lying down, the eyes must look toward the feet. The constant strain of turning the eyes down tires the muscles, so that the vision becomes blurred.

622. Diseases of the eye. — An ulcer or scar upon the cornea, closure of the pupil, cataract, and wasting of the optic nerve are common causes of blindness. If your eyes are sore, or red, or painful, you should consult a doctor at once; for blindness may result from what seems to be a mild trouble.

A particle of sand or other substance between the eyeball and the lids causes great pain. Rubbing the eyelid forces the particle into the delicate flesh and increases the pain and danger. If the lid is gently held away from the eyeball for a moment, the tears may wash out the particle.

The eye is well protected from injury, for the sclerotic coat is the strongest tissue in the body.

Eyes may become sore and run matter; or pimples may come on the edges of the lids. The soreness is usually caused by disease germs which enter the eye with dust and dirt. Some eye diseases are caused by using towels or handkerchiefs on which other persons have wiped their sore eyes, or by rubbing the eyes with dirty fingers which have touched the matter from the sore eyes of another person. Babies often have sore eyes because their eyes are not kept clean, or because flies are allowed to crawl over them. We should wash our eyes with clean water as often as we wash our faces, and should remove all scales and dried matter from the edges of the lids. If the eyes are red and tender, they should be washed with boiled water to which borax has been added, so as to kill the germs. In *granulated lids* the conjunctiva becomes red and roughened. A dangerous form of granulated lids, called trachoma, is catching, and often spreads among school children. Every person who has trachoma should be required to take treatment so as to prevent the spread of the disease.

623. Illusions of sight. — Irritating the optic nerve excites the sensation of light. A blow upon the head causes a sensation of seeing bright stars. Pressure upon the eyeball causes a sensation of a ring of light.

In dreams, sight memories return to consciousness with all the vividness with which they were first made. A crazy man may imagine the face of the clock to be a man's face mocking him, and so he may attack and destroy it. To insane persons of a religious turn of mind, a cloud may seem to be an angel urging them on to some inspired mission.

624. Effects of alcohol and tobacco. — *Alcohol* weakens the optic nerves, and tends to cause dimness of vision while the eyes may appear healthy. Tobacco has a still greater effect upon the optic nerve.

625. X rays. — In December, 1895, a kind of light produced by electricity was discovered which can penetrate wood, flesh, and other substances. By means of it photographs can be taken. Although it makes no impression

upon the retina, yet by passing it through certain substances the rays become visible to the eye. Bone is penetrated by the rays with greater difficulty than flesh, and so they can be photographed and seen within the body. These rays cannot be bent from their course, and so cannot be brought to a focus to produce a real image; but images of objects are formed in shadows, due to the varying degrees of light which passes through different objects.

The rays are sometimes called Röntgen rays from their discoverer, and sometimes simply X rays because of their unknown nature. Practical use of the rays is made in looking within the body so as to determine by sight the condition of the bones and the location of substances imbedded in the flesh.



A foot in a shoe.

(From an X ray photograph.)

626. The eye in lower animals. — In all fourfooted animals, and in birds, reptiles, and fishes, the eyes are essentially the same as in man.

Most *insects* possess large immovable eyes shaped like a dome. Each eye is made up of many smaller eyes like a honeycomb. Each little eye contains a lens which forms an image upon the nerve at the bottom of the cavity.

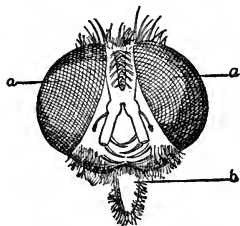

The eye of a house fly.

a eye, made of many small eyes. *b* mouth.

In some lower forms of animals, like the leech, there is a spot of dark coloring matter under the skin in which the nerves of sight end. Such eyes cannot form an image, on account of the absence of the lens, but a bright light or a shadow of a large object can affect the nerve and give the leech some idea of its surroundings. Some still lower forms of animals seem to be able to recognize light, for they fold themselves up

when darkness comes, and yet they have nothing which at all resembles an eye.

Some plants, like the morning glory, are affected by light, for their flowers fold themselves at night and open again when the sun rises.

SUMMARY

1. Light is the name given to the vibrations of a very rare gas which fills all space.
2. The eye is like a photographer's camera.
3. The eye is set deep in a bony socket, called the *orbit*, and is protected in front by the *lids*, and moistened by *tears*.
4. The eye can see distinctly only a small space directly in front, but can distinguish the presence of objects in a full half circle.
5. A sensation of sight is produced instantly, but persists for one tenth of a second after the light disappears.
6. Some eyes cannot see some colors, especially red.

7. If the lens cannot bring the rays of light together, a person is *far-sighted*, but if it brings the rays together too soon, he is *near-sighted*. If it brings some of the rays together sooner than others, the condition is called *astigmatism*.
8. If the lens does not permit light to pass through, the condition is called a *cataract*.
9. By means of the two eyes viewing an object from slightly different positions, we form an idea of position and solidity.
10. If one of the muscles of the eye pulls the eyeball to one side, the person is *cross-eyed* and sees two objects instead of one.
12. Irritation of the optic nerve causes a sensation of sight as though light had caused the impression. Memories of sight may be recalled so vividly as to seem real, as in a dream.

DEMONSTRATIONS

135. Examine the eyeball of a calf in its socket. Carefully separate the eyeball and its muscles and nerves from the fat. Notice the cushion of fat surrounding the whole eyeball. Notice the slender muscles which arise from the back part of the orbit and are attached to the outer edge of the eyeball. Notice the optic nerve entering the middle of the back side of the eye. Notice other nerves and the numerous blood tubes which cross the space. Preserve the specimen in Müller's fluid.

136. Procure several eyes removed from their sockets, and place some in Müller's fluid for a week or two, and examine others fresh.

Notice the bulging and clear cornea, and the tough white sclerotic coat. Holding the eye with its cornea toward you, cut it completely into halves. Notice the aqueous and the jellylike vitreous humors. Notice the curtain of the iris and its pupil. Behind the iris notice the lens. Remove the lens and note its shape and its firm consistency. Notice the black choroid coat lining the eyeball next to the sclerotic. Notice the thin retina, which readily separates from the choroid.

137. With a common magnifying glass show how a convex lens brings rays of sunlight to a focus. Show also a photographer's camera. Show the image which appears upon the ground glass. Then compare the camera with the eye specimen, pointing out the resemblances.

138. Have the students look steadily at a line of print and tell how much they can read without moving their eyes. An inch and a half will be all they can see at once.

Next have them look steadily at an object, and notice how they can see dimly all objects in a semicircle about them.

139. Illustrate the duration of impressions by spinning a square top. It will appear circular.

140. Illustrate the exhaustion of the retina by having the students gaze at a square of black cloth upon a white paper. After a moment let the students look steadily at the wall, when a square spot of light will appear, for the part of the retina upon which the image of the cloth fell is less exhausted than the rest, and so it sees the light from the wall more clearly.

141. Illustrate color blindness by taking a sheet of light pink paper. Have the students first look steadily at a bright red object in a strong light. Then gaze at the pink paper; a *green* image of the first object will appear, showing that a part of the retina has become exhausted for the red rays, but can still see other colors.

142. Notice the pupil of the eye and its varying size in different lights. Shade another person's eyes with the hands, and, quickly removing them, notice that the pupils grow smaller. Have a person look steadily at your finger held a few feet in front of the eyes, and then quickly bring the finger near the eye and notice that the pupil contracts while looking at it near by.

143. Illustrate a near-sighted eye by holding a magnifying glass in front of the eye, which is the same as increasing the power of the lens. Notice that the object must be brought nearer the eye.

Show a double concave lens and explain that it scatters rays and so is used in glasses for near sight.

144. Illustrate far vision by looking through two magnifying glasses of different strengths. Notice that the weaker glass must be held farther away from the object.

145. Place a book edgewise before the eyes and notice that one eye sees one side and the other eye the other side.

Now examine a stereopticon photograph of a statue, and notice that

the two pictures are not exactly alike. When the views are blended into one by the stereopticon; the image seems to stand out like a real statue. Explain that in this way the two eyes gain a knowledge of position and solidity.

146. Illustrate double vision by pressing one eyeball aside while looking at an object.

147. Have a person gaze at your finger held at a distance from his eye. Now bring the finger near the eye, and notice that the eyes each turn towards the nose so as to keep directed toward the object. This is the only manner in which we can move the eyes in opposite directions.

148. Press hard upon the closed eyelids. Notice the ring of light which appears. Explain that this is due to the irritation of the optic nerve.

149. Test the individual members of the class for color blindness by showing them shades of red, green, and yellow, telling them to match the shades and arrange them in order. Also test the power of vision of the individual members of the class by placing before them printing with letters of various sizes. Have each pupil read as far as he can, all standing at the same distance.

REVIEW TOPICS

1. Describe light; color; focus; and the effects of light in a photographer's camera.
2. Show that the eyeball is like a photographer's camera, describing its outer coverings; its retina; nerve; cornea; iris, pupil, and lens.
3. Describe the orbit; eyelids; the lachrymal gland; tears, and the tear ducts.
4. Show that a person can see more clearly directly in front of his eyes than upon either side.
5. Show that the duration of a sight sensation changes the appearance of moving objects.
6. Describe *color blindness*.
7. Show that the retina may become unable to act from overwork, as by gazing at bright objects; at colored

objects; and by a light in front of the unshaded eyes.

8. Show that the iris protects the retina against too strong light.
9. Show that the lens must change its shape to accommodate itself to near vision and to far vision.
10. Tell the condition of the lens and the remedy in *far* sight; in *near* sight; and in *astigmatism*.
11. Describe a cataract and its remedy.
12. Show how two eyes aid in the judgment of form and position.
13. Describe the condition of the eye muscles in a cross-eyed person, and tell how vision is affected.
14. Show how reading upon a moving railway train and reading while lying down overwork the eye muscles.
15. Tell how to care for an eye which runs matter, and how to remove a speck of dirt from under the lid.
16. Show that rubbing a sore eye is always liable to do harm.
17. Show that irritation of the eye may produce false sensations of sight; and that sight memories may seem to be real again.
18. Describe the *X rays*.
19. Describe the effects of alcohol and tobacco on the eye.
20. Describe the eye in lower animals; in insects; and in a leech.

CHAPTER XXXVI

THE VOICE

627. The larynx. — The basis of the voice is a sound made in the larynx during expiration. The larynx is a triangular box about three quarters of an inch across, made of cartilages. It connects the trachea and pharynx. Its two sides are formed of a flat cartilage, bent sharply backward, and called the *thyroid* cartilage. The upper end of the fold projects slightly from under the chin and is called the *Adam's apple*. Underneath the thyroid cartilage is a circular cartilage whose back part projects upward so as partly to fill in space between the back edges of the thyroid cartilage. In form and size it resembles a large finger ring, and is called the *cricoid* cartilage.

On top of the back part of the cricoid cartilage are two small cartilages, shaped like triangular pyramids, and so arranged that they can turn sidewise. One lower corner of each projects forward. From it a flat band extends across the larynx, and, with its fellow from the opposite side, attaches itself to the lower part of the thyroid cartilage. Muscles can tighten them and bring them close

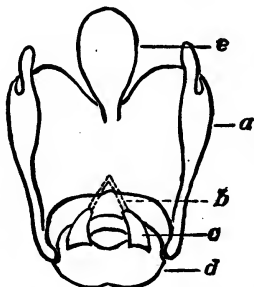

Back view of the larynx.

- a* thyroid cartilage.
- b* vocal cords.
- c* movable cartilage for the attachment of the vocal cords.
- d* cricoid cartilage.
- e* epiglottis.

together. Expiring air between these bands, while they are tight and close together, causes them to vibrate and produce a sound which is called the *voice*. Hence the

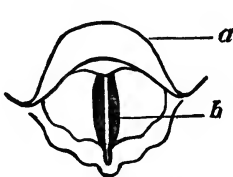

Top view of the larynx, with the vocal cords closed, as in speaking.

a epiglottis. *b* vocal cords.

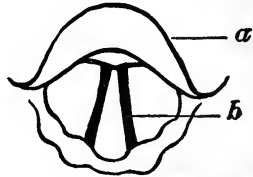

Top view of the larynx, with the vocal cords open, as in breathing.

a epiglottis. *b* vocal cords.

bands are called the *vocal* cords. The whole larynx, except the edges of the vocal cords, is covered with loose mucous membrane.

628. Pitch of the voice. — All sound has the four characteristics of *pitch*, *intensity*, *quality*, and *duration*. The same characteristics apply to the voice.

Pitch depends upon the number of vibrations which occur each second. In order that the vibrations of the air shall blend into a musical note they must occur at the rate of sixteen times a second, but until they reach a rate of fifty the sound is more like a buzz than music. Upper C of the bass voice which corresponds to lower C of a soprano, is produced by 256 vibrations per second. The shorter or tighter the vocal cords are, the higher will be the pitch. In men the cords are longer than in women, making a man's voice an octave lower in pitch. The larynx and voice of a boy resemble those of a girl. At about the age of fifteen the voice of a boy becomes like a man's, while in a girl it remains unchanged.

629. The intensity of the voice depends upon the force with which air is expelled through the larynx. In making

a very loud sound, the great force of the air current causes the vibrations of the vocal cords to be painful.

630. The muscles of the larynx will grow strong by judicious practice, so that a person can be heard across a hall in which he formerly could not be heard a few feet away. If the voice becomes husky, or causes a cough, or if the throat begins to feel painful, the vocal cords are being overworked and should be rested.

631. Quality of the voice. — A string stretched between the hands produces a faint unpleasant sound; but if it is stretched over a hollow box, like the body of a violin, the whole box will vibrate and greatly magnify the sound and also will make it full and pleasant.

The vibrations of the vocal cords alone produce a faint and almost squeaking sound very unlike that of the voice; but below the larynx are the hollow trachea and lungs. Above it are the hollow mouth, nose, and frontal sinuses. All these vibrate with the vocal cords, and so the quality of the voice is modified. Each person's voice has a peculiar quality of its own which is at once recognized.

When a person sings with the nose stopped, we say that he sings through the nose. In reality, a nasal voice is due to the absence of vibrations in the nose.

632. Ventriloquism. — The quality of sound is modified by distance, so that one can judge accurately whence it comes. It is possible to imitate the quality of distant sounds, so that there seems to be another person talking in a remote part of the room or inside of the real talker. This is called *ventriloquism*.

633. Speech. — Speaking consists mainly in rapid changes in the quality and duration of vocal sounds. In singing or crying out, single sounds are more or less prolonged, but in forming spoken words, the sounds are cut off by the tongue and lips several times a second. It is not even necessary to form a sound with the larynx. In whispering,

air is simply breathed through the mouth, while the tongue and lips cut it off at intervals as though a sound were being made.

634. A simple sound continuously uttered is a *vowel* sound. If the mouth is simply opened without effort, the sound formed will be that of *a* as in *father*. When the mouth is closed the most, it forms the sound *oo* as in *room*. A consonant sound is a vowel sound suddenly modified in either its beginning or ending. For instance, when the tip of the tongue is held against the palate just back of the teeth, and a vowel sound is begun by forcibly blowing it away, the sound will be either *t*, *d*, or *th*.

635. Rate of talking. — A public speaker will ordinarily utter 125 words a minute. On an average each word will be composed of, at least, four different sounds. Thus the vocal organs must make 600 separate adjustments each minute, or 10 each second.

636. Relation of sound and speech. — Words spoken must first be heard. So no matter what the race of a child, it will speak exactly the speech which it hears. If a child is brought up in company with an ignorant nurse girl, its speech will be her brogue. On the other hand, if the child is brought up among educated and refined persons, it will speak an elegant tongue.

A deaf person has great difficulty in learning to speak at all, for he can have no idea of the sound which he should make. Without special instruction deaf persons would never learn to speak at all, but by letting them see or feel the position of the lips and tongue in forming words, they learn to place their own parts in the same position and so finally learn to talk.

637. Necessity of the tongue in speech. — The tongue is usually considered to be so necessary in speech that the language itself is called a *tongue*. As man's mouth is constructed the tongue does do the most important part of forming words, but if the organ is removed as far back as possible, the stump can still form intelligible words. Sometimes the front part of the tongue is bound down or "tied" so that it cannot move so freely as it should. This is supposed to hinder a child in talking, but in reality it does not.

638. Benefits of vocal exercise. — In singing and lecturing, the breathing must be regular and deep. The abdominal muscles must act, and often a sound must be prolonged until the air in the lungs is exhausted. The respiratory muscles must act continuously and strongly and for long periods of time. Thus an increased amount of oxygen will be taken into the body. Voice training is one of the best modes of exercise, especially for a weak person who cannot endure long walks or gymnastic exercises. It is all the more valuable because a person does not think of the exercise, but directs the mind to an interesting and useful occupation.

639. Diseases of the larynx. — In a cold in the throat the mucous membrane becomes tender and swollen. Then the movements of the vocal cords are impeded and painful, so that only a hoarse sound, or no sound at all, can be produced. By repeatedly overworking the vocal cords, they and the muscles of the larynx become flabby and tender so that their vibrations are painful or impossible. Then the voice is reduced to a whisper. Sometimes the nerves of the larynx are paralyzed so that no motor orders can reach the muscles. Then no sound can be formed.

640. In mouth breathing, the air is drawn directly into the larynx without being purified, warmed, and moistened in the nose. This irritates the larynx and vocal cords so that the voice is made weaker and harsher. A mouth breather can seldom become a good singer or speaker.

641. Tobacco. — Tobacco smoke may produce such an irritation that there is a constant hacking cough. Cigarettes are especially bad for the voice, for the smoke is deeply inhaled. Alcohol interferes with the voice by inducing indigestion and weakness of the muscles.

SUMMARY

1. The larynx is a box of cartilage across which two strong bands called *vocal cords* are stretched.
2. When the vocal cords are tightened and air is expelled between them, a sound called the *voice* is made.
3. The pitch of the voice will depend upon the tightness and length of the cords.
4. The intensity of the voice depends upon the force with which the air is expired.
5. The quality of the voice is imparted to it by vibrations of the air in the lungs, mouth, and nose.
6. In speech sounds are modified mainly by the lips and tongue.
7. A man must first hear the sound of speech, and then learn to imitate it. Special means must be employed to teach a deaf person to talk.
8. If the vocal apparatus is overworked or becomes inflamed, the voice is injured.

DEMONSTRATIONS

150. Procure a larynx from a butcher's shop. Notice the large flat thyroid cartilage, and under it the ring-shaped cricoid cartilage. Notice the white vocal cords passing forward to the lower part of the thyroid. Notice the loose mucous membrane above the vocal cords. Grasp the thyroid cartilage so as to move the cricoid forward and backward, and note how the movements tighten and relax the vocal cords. Notice the muscles which move the larynx. Test the pyramidal cartilages to which the vocal cords are attached.

151. If possible, get a physician to show the vocal cords in action upon a living person. He will do it by means of a small mirror held in the back part of the mouth.

152. Have the pupils feel each other's chests while counting one, two, three, and note the marked vibrations. In the same way feel of

the larynx and of the nose and teeth. Explain that these vibrations also produce sound and give quality to the sound in the larynx. Then compress the nose and note the nasal quality of the voice.

153. Show how the different vowel sounds are formed. Make a continuous sound as of *e* in *need*. Without changing the pitch or intensity change the mouth to a position to utter in succession the sounds *a* as in *made*, *a* as in *mat*, *ah* as in *father*, *o* as in *note*, and *oo* as in *room*. Note how the sounds glide into each other.

154. Note the positions of the tongue and lips in uttering the different consonant sounds. Note that *p*, *b*, and *f* are formed much alike; and also *k*, *ch*, and *g*; and *t*, *d*, and *th*.

155. Show how some lower animals and insects produce sounds. Have the pupils notice how a canary bird swells his throat in singing, and explain that this is because it has two or three pairs of vocal cords.

Upon the backs of a katydid's wings show the drumheads, which, when rubbed together, produce its sound. Show that a fly's buzz is due to the exceedingly rapid motion of its wings.

REVIEW TOPICS

1. Describe the larynx.
2. Show how the vocal cords produce sound.
3. Show how the *pitch* of the voice can be changed.
4. Show how the *intensity* of the vocal sounds can be changed.
5. Show how the *quality* of the voice is modified.
6. Describe *ventriloquism*.
7. Show that speech depends upon modifications in the duration and mode of production of vocal sounds.
8. Show the relation between speech and hearing.
9. Show that the tongue is not absolutely necessary in speech.
10. Show how vocal exercise benefits the whole body.
11. Show how inflammation of the larynx and taking certain things into the mouth injure the voice.

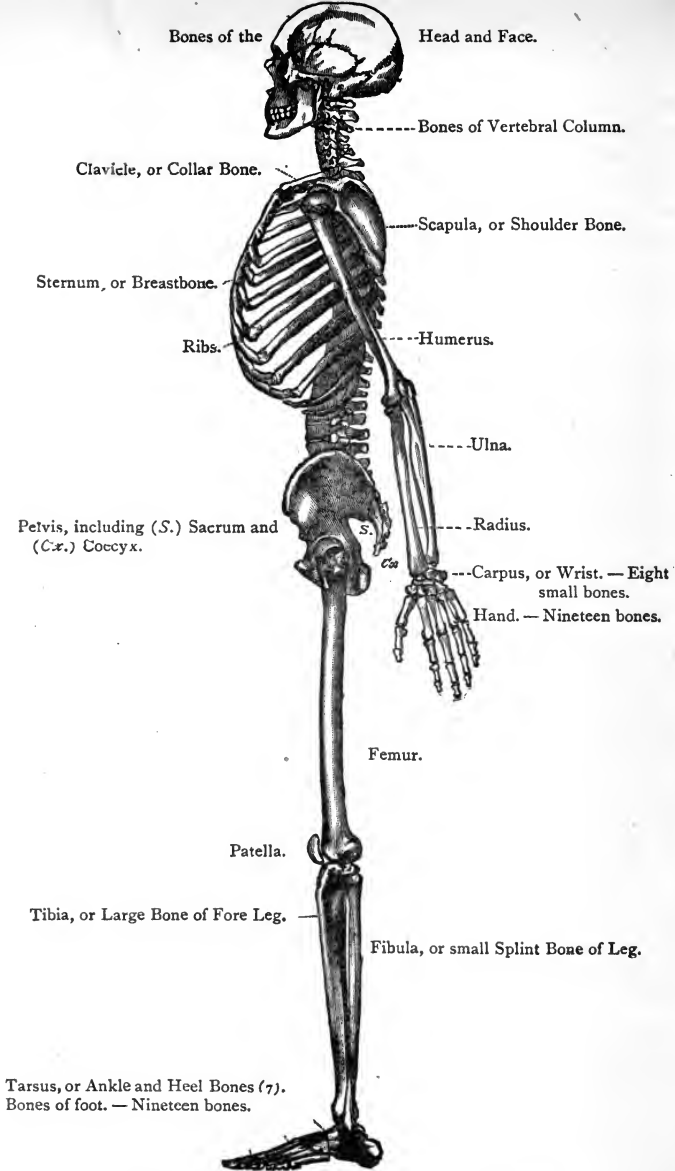

The human skeleton, showing position of bones.

CHAPTER XXXVII

BONES.

642. Use of bone. — Bones give shape and support to the body and impart to it strength and stiffness. Like beams of the strongest oak, they extend the length of every limb, and form arches for the protection of the organs in the head, chest, and abdomen. They are of various sizes and shapes, as are suited to the different parts. In the whole body, about two hundred are jointed together to form its framework, called the *skeleton*.

643. The skeleton. — Eight rounded plates of bone form the top of the head, and fourteen of irregular shape form the face. Together, they form the *skull*.

Twenty-six irregular rings of bone piled one upon the other form a support for the trunk of the body. It is called the *backbone* or *spinal column*, or simply the *spine*. The lowest bone is called the *coccyx*, and the one next above it, the *sacrum*. Each ring of bone is called a *vertebra*. The spine is made of a series of small bones so that it can bend without breaking. It is gently curved so as to lessen the jarring in running and other violent movements of the body.

From the vertebræ, beginning at the eighth, twelve pairs of bones called *ribs* curve around the body. In front they join a flat bone called the *sternum* or *breastbone*. They inclose and protect the heart and lungs.

Each shoulder is formed in front by a slender bone

called the *collar bone* or *clavicle*, and behind by a flat bone called the *shoulder blade* or *scapula*. Their outer ends meet and form a support for the arm.

The upper arm has one long bone called the *humerus*. The forearm has a long bone on its thumb side called the *radius*, and another on its little finger side called the *ulna*. The wrist has eight rounded bones called *carpal* bones. The palm of the hand has five long bones



The spinal column.

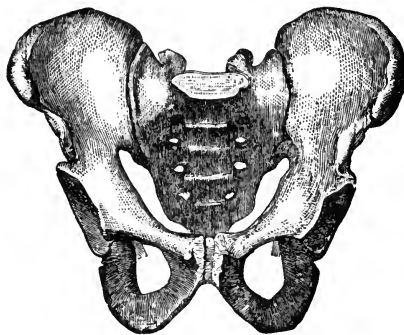

The pelvis.

called *metacarpal* bones. The fingers have fourteen slender bones called *phalanges*.

Two irregular and massive rings of bone form the *hip* bones. With the *sacrum* they form a ring called the *pelvis*. The body sits upon the lower part of each hip bone. The pelvis forms the bottom of the abdomen.

The bones of the leg have nearly the same plan and arrangement as those of the arm. The thigh has one long bone called the *femur*. In front of the knee is a flat bone

called the *patella*. The shin is formed by one long bone called the *tibia*, upon the outside of which is a very slender bone called the *fibula*. The lower end of the fibula forms the outer ankle bone, while a projection from the tibia forms the inner ankle bone.

Seven rounded bones, called *tarsal* bones, form the instep of the foot. Five slender bones beyond them, called *metatarsal* bones, form the ball of the foot. The tarsal and metatarsal bones are bound together so as to form an arch which bears upon the ground only at the heel and ball of the foot. The arch is somewhat elastic and prevents jarring of the body in walking. It sometimes becomes flattened, producing the painful deformity called *flat foot*. Fourteen slender bones, called *phalanges*, form the toes.

644. Structure of bones. — Bones are dense and brittle upon the outside. All are covered with a very tough membrane, called the *periosteum*. In flat or rounded bones the hard outside surfaces are scarcely thicker than paper, and the two surfaces are connected together by a network of bone which looks like a honeycomb, and is called *cancellous* bone.

In long bones, the central shaft is composed of a thick shell of hard bone surrounding a cavity filled with fat; their ends consist of a thick shell of hard bone covering a large mass of cancellous bone.

A bone is about twice as strong as a piece of oak of the same size. It is elastic and can bend considerably without breaking. Any given weight of a substance is stronger when made into a hollow shaft, like a bicycle frame, than when formed into a solid rod of the same length. So the strength of a bone is still further increased by its being either hollow, as in the shaft of a long bone, or else braced with cancellous bone, as in a flat bone and the ends of a long bone.

645. Microscopic appearance. — Bone is composed of branching connective tissue cells and fibers, which are arranged in circles around minute tunnels called *Haversian canals*. Each Haversian canal contains arteries, veins, and nerves. Lime is mixed with the cells and canals like starch among the fibers of linen, and imparts to them their

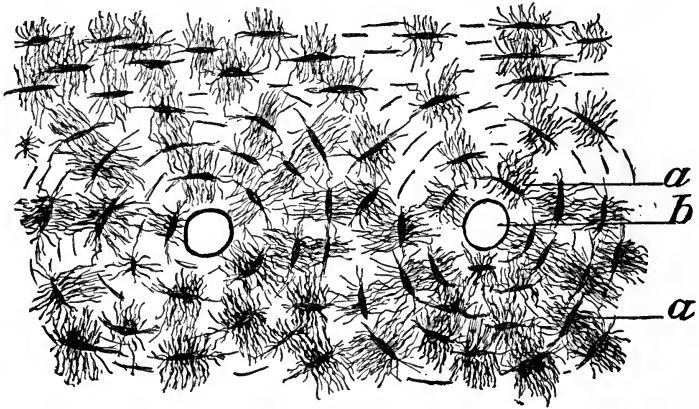

Thin slice of bone ($\times 200$).

a bone cells. *b* Haversian canal, containing blood tubes and nerves.

hardness and rigidity. Lime forms about two thirds of the bone by weight.

646. The periosteum carries arteries and nerves which enter minute openings in the bone. During childhood, or when a bone is diseased, the cells of its inner layer are very active in reproducing themselves and in forming new bone. Bone stripped of its periosteum is apt to die, but when the bone dies the periosteum usually remains alive and soon reproduces new bone. The periosteum also affords an attachment for muscles.

647. Cartilage. — The bones of very young animals contain little or no lime, but are soft and pliable. In this

condition they are called *cartilage*. As age advances, lime is deposited among the cells, and they become hard and brittle, forming true bone. A layer of cartilage remains to cover the ends of most bones. Late in life it may take up lime and so become like bone.

648. Rickets. — Sometimes a child's bones contain too little lime ; then under the influence of continual pressure of standing, the bones of the leg may gradually grow into a bowed shape. This disease is called *rickets*, and is due to too little nourishment. When fed on a sufficient amount of proper food, the bones soon grow rigid again, and as the child's legs grow longer, their curves become less noticeable.

649. Broken bones. — Bones are often broken. Then the cells are injured, and blood tubes and nerves are torn across. So there will be great pain and tenderness. When a bone is broken, its cells reproduce themselves and fill in the space with new connective tissue. In course of a few weeks, lime is deposited in the new tissue, and the union is complete. When a bone is broken, the surgeon pulls its ends in place and binds them to stiff splints until healing is complete.

If a bone is broken, the limb should be at once bound to a board or stick with handkerchiefs or strips of cloth. Take care not to tie the bands tightly enough to stop the flow of blood.

As a person grows older, more lime is deposited in his bones, and they become harder and more brittle. Then they are more likely to be broken and are less able to grow together again. Often a child's bone will bend until it breaks, but its ends still hold together like a broken green stick. In older people it snaps like a dry twig.

650. Diseases of bones. — Bruises or consumption or other causes of disease may produce inflammation and abscesses of the bone as in any other part of the body. Then the bone is very painful and tender and may die. Then the periosteum will form a new bone. If a large piece of bone dies, it wastes away more slowly than new bone is formed. All fourfooted animals have nearly the same bones arranged

in the same way as man. A bird's wing is bone for bone almost like a man's arm and hand. A turtle's shell is its ribs, while the bones of its limbs are like those of man.

SUMMARY

1. About 200 bones give the body form and strength.
2. The outside of all bone is a hard plate, while the inside is either a fine network of bone or else is hollow.
3. The hollow form of bone combines strength with lightness.
4. Bone is composed of living cells and fibers nourished by arteries and endowed with sensibility by nerves. Lime is mixed with the cells like starch with linen.
5. Bone is covered with a tough membrane called the *periosteum*, which carries the blood tubes and nerves to the bone, and forms new bone during the period of growth or when the bone is diseased.
6. Cells and fibers resembling those in bone, but containing no lime, form *cartilage*.

DEMONSTRATIONS

156. Show a complete skeleton of at least a small animal. Point out the different shapes of the bones and how they are adapted to their positions and work. Point out in the living body where the different bones can be felt.

157. Procure a fresh beef bone, and another similar one dried. Note the bright pink color of the fresh bone, and the white or brown color of the dried specimen. Notice that the periosteum can be stripped from the bone. Notice the soft cartilage which covers the ends of the bone.

158. Saw a long bone in two crosswise and then saw one half in two lengthwise. Notice the hollow cavity in the shaft of the bone and the fat or marrow which fills it. Notice the honeycombed appearance of the inside of the ends of the bone.

159. Procure a specimen of bone mounted for the microscope. Using a power of at least fifty diameters, notice the circles of bone cells

and the numerous fine branches of the cells. Notice the Haversian canal in the center of each circle. Examine also a specimen of cartilage.

160. Procure two slender bones which are exactly alike. Place one in a hot fire for a few hours. This will burn out the cells and fibers and leave only the lime. The bone is now very brittle and easily crumbles to pieces. Place the other in a bottle containing one part of muriatic acid and ten of water. After a week this acid will have removed the lime, leaving only the cells and fibers. The bone can now be twisted and bent like a piece of flesh.

161. Boil a leg bone of a half-grown animal until the flesh is removed. Notice that a disk of cartilage extends nearly through the shaft very near the ends. Possibly the end beyond it will come off. Explain that the cartilage forms new bone which increases the length of the shaft as long as the bone continues to grow.

REVIEW TOPICS

1. Show why bones are needed in the body.
2. Describe the bones of the skull; of the spine; of the ribs; of the arms; of the pelvis; and of the legs.
3. Describe the appearance of a bone when sawed in two both lengthwise and crosswise.
4. Show the advantage of having some of the bones hollow.
5. Describe the microscopic appearance of bone.
6. Give the uses of periosteum.
7. Describe cartilage.
8. Describe the changes which occur in bones with advancing age.
9. Describe rickets.
10. Describe the condition of a bone when broken, and tell how it is repaired, and how to care for a broken limb.
11. Show how a bone can become inflamed; and how dead bone is replaced.

CHAPTER XXXVIII

JOINTS

651. Kinds of joints. — The union of two bones is called a *joint*. Some bones grow together and form a single rigid bone, while others are joined together only by loose fibrous tissue which permits the joints to bend freely. Between these two extremes, joints possess all gradations of movement.

652. Inflexible joints. — Some bones of the skull are joined together by cartilage during childhood. Later in life, when growth ceases, the cartilage becomes bone and unites the two bones into a single one.

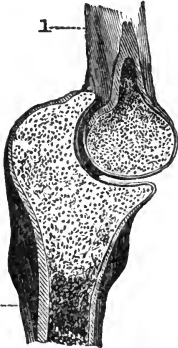

Hinge joint of the elbow.

1 humerus. 2 ulna.

Other bones of the skull are dove-tailed with each other, so that while they can move slightly, they cannot be separated. The thick bones of the top of the skull are united in this way.

Between the separate bones of the pelvis and between the vertebræ there are large pads of fibrous tissue, almost like cartilage. These pads permit slight movements between the bones and so prevent jarring during violent movements of the body. They are usually stronger than bone itself, so that, by pulling or bending, the bones will be torn apart rather than the pads.

Between the ends of the ribs and the sternum there are cartilages of the shape of the ribs. In old age they often take up lime and become real bone.

653. Flexible joints. — The joints of the head and trunk of the body are mostly inflexible, while those in the limbs permit very free movements of the bones. In flexible joints the bones are held together by a strong fibrous membrane called a *ligament*. The ends of the bone are smooth and rounded so as to move freely upon each other.

In some joints the movements are simply forward and backward like a hinge. The fingers, toes, elbows, knees, and ankles are hinge joints.

In some joints the movements can be made forward and backward and sideways like a ball in a socket. The thumbs, great toes, shoulders, and hips have this kind of a joint. In each the end of one bone is spherical and fits into a hollow socket in the other.

In other joints one bone can only rotate about another as a pivot. In its union with the spine, the skull turns about a fingerlike projection upon the top of the second vertebra. At the elbow, the upper end of the radius turns in a socket upon the side of the ulna through half a circle of revolution.

654. Structure of joints. — In all flexible joints the ligaments pass from bone to bone, like a collar upon the outside of the bone, enveloping a cavity which is lined with a thin and smooth membrane, called *synovial membrane*. The synovial membrane secretes a fluid like the white of an egg, called the *synovial fluid*. The fluid moistens and lubricates the joint so that it turns smoothly and easily. If it is absent the joint creaks when moved.

655. Loose joints. — The two bone surfaces of each joint fit together accurately. There is a considerable difference in the depths

of the joint sockets and in the lengths of the ligaments in different persons. In some persons the sockets are shallow and the ligaments long, so that the joints can be bent to a far greater degree than usual. These persons are able to twist and contort themselves into strange positions and shapes, and thus they make good circus actors.

656. Action of muscles as ligaments.— Nearly every joint is crossed by muscles. By their pressure the muscles aid in keeping the bones in place. In addition, when one muscle acts, those upon the opposite side of the joint also contract enough to prevent the head of the bone from being drawn out of its socket.

If all the muscles and cords about a joint are cut, the ligaments stretch and the joint becomes loose and flabby. If the ligaments are cut while the muscles and cords are left, the joint remains snug and firm.

657. Effects of pressure.— After being kept in an unnatural position for some time, joints tend to retain the deformity. In wearing tight shoes, the great toes are bent outward, while the little toes are bent inward. If the joints are kept in this position day after day for years, they remain permanently fixed in the deformed position. The great toe joint may be tender, forming a *bunion*.

658. Curvature of the spine.— The spine is naturally straight from side to side. Strong muscles aid in keeping the head erect and the shoulders thrown well back. By weakness of the muscles or by carelessness the shoulders fall forward, increasing the natural curve of the spine so that a person becomes *round shouldered*.

If a child habitually sits sidewise at the desk, leaning continually upon one arm, the growing bones and the ligaments of the spine will gradually become fixed in the deformed position, which persists all through life. Any person who, in his occupation, always assumes the same attitude, may finally be unable to remove the curvature from his spine. On the other hand, if one acquires a habit of sitting and walking and working in an erect position, the spine will grow in a natural curve.

659. Sprains. — When a joint is bent to a greater extent than is natural, the ligaments and muscles are stretched and often torn. Then there will be great swelling and pain. When this accident happens, the joint should at once be put in water as hot as can be borne, while more hot water is added from time to time to keep up the temperature of the water. The joint should have rest for some time after the injury. Recovery is apt to be slow.

660. Dislocations. — When the bones of a joint are forced apart, the joint is *dislocated*, or *out of joint*.

In a dislocation, the ligaments are always torn. Then bleeding will take place, and there will be great pain and swelling, while only slight movements of the limb will be possible.

In a dislocation, the muscles around the joint are irritated, and so contract and hold the bone away from its socket. Often it is necessary to make a person insensible with ether before the muscles will relax enough to get the joint in place.

When a joint is dislocated, the limb should be kept as quiet as possible by binding a splint above and below the joint, as in a broken bone.

661. Inflammation of joints. — Sometimes the synovial membrane becomes inflamed and pours out a quantity of thin fluid which distends the joint and produces great pain. In rheumatism this often occurs. Sometimes a blow or a wrench may cause it.

Sometimes waste matter of the body is deposited in the synovial membrane and cartilage. This produces great pain and tenderness and constitutes an attack of *gout*. The great toe joint is especially liable to this disease.

Sometimes the cartilage and ends of the bone become distorted and rough, or form hard swellings. Then the limbs cannot be bent without producing pain and a creaking sensation. This change naturally occurs

in old persons, and is due partly to deposits of lime in the cartilage and partly to a dry state of the synovial membrane.

Sometimes a joint slowly swells and discharges yellow matter for a long time, while the sufferer gradually loses flesh and strength. The disease is commonly known as a *white swelling*, but is really *tuberculosis*, or *consumption* of the joint. When it affects the hip joint, it is called *hip joint disease*. A form of the disease without the discharge of matter may affect the spine and produce the deformity called a *hunchback*.

SUMMARY

1. The union of two bones is called a *joint*.
2. In joints in which the bones do not move, the bones are united either by bone or strong pads of fibrous tissue, or by cartilage, or by being dovetailed into each other.
3. In flexible joints, bones are joined together by a collar of fibrous tissue and by the action of muscles.
4. Flexible joints are lined with synovial membrane, which secretes a fluid like the white of an egg to lubricate the joint.
5. By assuming one position day after day the joints become fixed in that position.
6. In sprains and dislocations the ligaments are stretched or torn, and require long rest in recovery.
7. The synovial membrane may become inflamed and swollen.
8. A joint may become affected with tuberculosis, forming a *white swelling* or *hip joint disease*. In it the joint forms an abscess and often discharges matter.

DEMONSTRATIONS

162. A fowl dressed for the table will illustrate the different kinds of joints. Notice that in some places the muscles unite with the ligament and in others simply cross it, usually as a white cord or tendon. Cut

the ligaments half in two to show the cavity of the joint. Notice the smooth and shining appearance of the synovial membrane which lines the joint and its slight amount of synovial fluid. Bend the joint back and forth to show how the surfaces of the bone fit into each other. Sketch a joint.

163. Notice some of the inflexible joints. In an animal's skull notice that the joints are dovetailed together with but little cartilage between. Notice the tough pads between the vertebræ, and how they permit the spine to bend slightly. Notice that the ribs are united to the sternum by flexible cartilage.

164. To show that muscles and cords act as ligaments, clench the fist tightly. Notice that the cords upon the back of the hands tighten, as well as those which shut the hand.

REVIEW TOPICS

1. Describe and locate the inflexible joints with bony union; with union by cartilage; with union by pads of fibrous tissue; and with union by being dovetailed together.
2. Describe and locate hinge joints; the ball and socket joints; and the pivot joints.
3. Describe the structure of joints, their ligaments, synovial membrane, and fluid.
4. Show how muscles aid the action of the ligaments.
5. Show how long-continued pressure affects the joints, as in the great toe.
6. Show how the position of the body may produce curvature of the spine.
7. Describe the nature and treatment of a *sprain*, and of a *dislocation*.
8. Show how joints may become inflamed.
9. Describe a *white swelling*.
10. Describe a *bunion*.

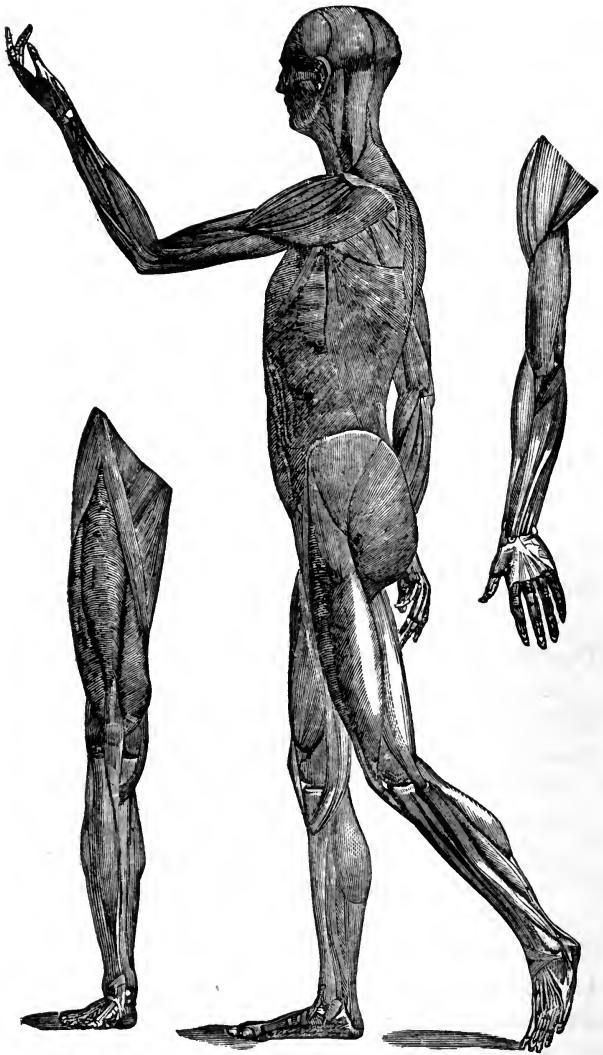

The muscular system.

CHAPTER XXXIX

MUSCLES

662. Movements within the body. — Every action of the body has motion for its basis, and every cell possesses motion of some form. But certain cells of the body are set apart to produce motion in the various liquids of the body and to move different parts of the body itself. Cells whose work is to produce motion are called *muscle cells*.

663. Involuntary muscles. — Some movements of the body go on wholly without our knowledge and are not affected by the will. Such are the movements of the blood, and of the peristalsis of the intestine. These involuntary movements are produced by muscle cells which are governed by the sympathetic nervous system. Each muscle cell resembles a string with pointed ends. They are wrapped around the arteries, intestine, bronchi, and other hollow organs. They are interwoven with the other tissues of the organ and cannot be recognized without a microscope.

664. Voluntary muscles. — The muscles which enable the body to move are under control of the will. They are situated mostly upon the outside of the bones, and altogether form over one half of the weight of the body. They round out the figure and impart to it strength and beauty. The other organs of the body of man exist in order that the brain and muscles may subsist and work out the plans of man's higher nature.



A muscle cell
($\times 400$).

The lean part of meat is muscle. Each muscle can be split lengthwise into bundles again and again until each muscle cell is separated from the rest. Connective tissue binds the whole together.

A muscle cell is a cordlike body about $\frac{1}{500}$ of an inch in thickness. Extending crosswise upon its surface are alternate dark and light bands which serve to distinguish a muscle cell from all other cells of the body. Each cell is surrounded but not penetrated by a network of capillaries and is held in place by delicate fibers of connective tissue, which are always small in quantity compared with the cells.

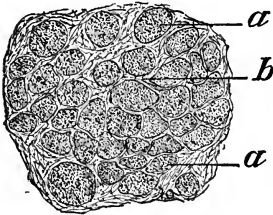

Muscle cells cut across
($\times 200$).

- a muscle cell.
- b connective tissue binding the cells together.

665. Attachment of muscles.—One end of a muscular bundle is usually attached to the periosteum of a bone, while the other end is joined to a string of connective tissue called a *tendon*. A tendon is a white pliable cord and is exceedingly strong. It runs in a groove lined with synovial membrane, and its end is usually attached to a bone. A muscle usually forms a rounded projection above a joint to be moved, while its tendons extend across the joint and are attached to the periosteum of the next lower bone. This arrangement keeps the weight of the limbs near their upper extremities.

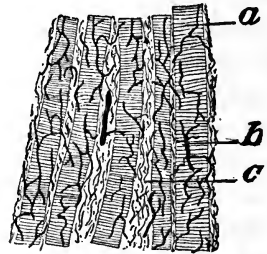

A thin slice of a voluntary muscle cut lengthwise ($\times 100$).

- a muscle cell.
- b capillaries surrounding the cells.
- c connective tissue binding the cells together.

666. Contraction of muscles. — When a muscle cell is cut or pinched or irritated in any way, it becomes shorter and thicker. This is called a *contraction*, and is the essential peculiarity of muscles. An end of a motor nerve thread touches every muscle cell and conveys to it orders from the cells of the spinal cord and brain. Each order causes a contraction.

A muscle cell requires about $\frac{1}{20}$ of a second to contract and another $\frac{1}{20}$ of a second to become relaxed. So it is impossible to move a limb more than ten times a second. The brain sends about ten orders per second. Thus before the muscle relaxes it receives another order and so remains in a tremulous state of contraction which becomes apparent during excitement or when a great effort is being made. Each contraction is a change in the shape and not in the size of the muscle.

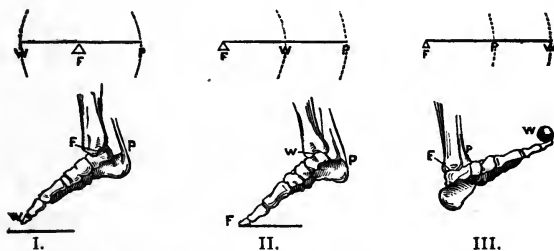

The three classes of levers, and also the foot as a lever.

667. Bones as levers. — A rigid bar turning about a fixed point or fulcrum is called a *lever*. When the weight is at one end of the bar and the power at the other end while the fulcrum is between the two, the bar is called a lever of the *first* class.

When the weight is between the power and the fulcrum, the bar is called a lever of the *second* class.

When the weight is at one end, the fulcrum at the other, and the power between, the bar is called a lever of the *third* class.

If the power is farther away from the fulcrum than the weight, it will move a weight greater than itself, but if it is a less distance away, it can move only a weight less than itself.

A bone is a rigid bar. The joint is the fulcrum upon which it turns. The power is the contraction of the muscles which are attached to it. The weight is the weight of the body or limb together with anything which may be grasped.

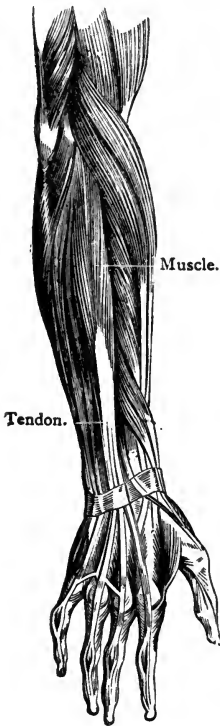

Right forearm.

668. Levers of the first class are not numerous in the body. The foot when pressing down with the toes, and the head when it is raised, are two examples.

669. Levers of the second class are also few. The best example is the foot when standing on the toes. The power is attached to the heels and is furnished by the muscles upon the back side of the leg below the knee. They end in a very strong tendon called the *tendon of Achilles*, which can be felt under the skin above the heel. It is the largest tendon in the body.

670. Levers of the third class are the most numerous. The foot in raising a weight upon the toes is an example. In nearly all joints of the arms and legs the power is furnished by the muscle attached to a bone near the fulcrum or joint, while the weight is farther away or near the outer extremity of the bone. Most of these muscles are so attached to their bones that they must exert a force

greater than the weight which they move. But the outer end of a lever moves over a greater distance in a given time than the part near the fulcrum. So if a muscle loses power by its attachment to a bone, it gains in rapidity of motion. The muscles of the body are strong enough to combine strength with quickness of motion.

The joints of the arms and legs are mostly so arranged that the limb can form a straight line, but can be bent in only one direction. The muscles which bend a limb are called the *flexors*, while those which straighten it are called *extensors*. Flexor and extensor muscles are usually arranged in opposing pairs, with the flexors upon the front and the extensors upon the back side of the limb. The flexor of the elbow reaches from the elbow to the shoulder upon the front of the arm and is called the *biceps*. The extensor of the elbow extends in the same way upon the back of the arm and is called the *triceps*. Both the flexors and extensors of the wrist and fingers are situated between the elbow and the wrist. Only a few small ones are in the hand.

The muscles which flex the knee end in strong tendons which can be felt as the hamstrings upon the back of the joint. The muscles which extend the knee end in a single large tendon inside of which is the patella. The patella acts as a pulley to protect the joint from the action of the tendon.

The muscles of the ankles and toes are arranged much like those of the wrist and fingers. By practice while young, it is possible to learn to use the toes in the same way as the fingers.

671. Back muscles. — The backbone is held upright and bent backward by large muscles which form ridges upon each side of the spine. They stretch the whole length of the spine so that the weight and power are at the same place while the fulcrum is the point of bending. Thus the spine is equivalent to a lever of the second or third class which uses most of the power of the muscle. So the back possesses great power with slow motion.

672. Standing is done by the contraction of the opposing flexor and extensor muscles of the lower part of the body, so that the

spine and legs are held rigid. If one set overacts, it pulls the body to one side and tends to upset it. Then the opposing set contracts and rights the body. In standing, the two sets continually act in this way.

Walking is due to a regular action of the flexor and extensor muscles of the leg, in such a way that there is always one foot upon the ground. In running, the whole body is completely removed from the ground at every step.

673. Face muscles. — The expression of the face is due to flat muscles which are attached to the skin. A circular muscle surrounds the mouth and each eye, while other muscles radiate from their edges. The contractions of

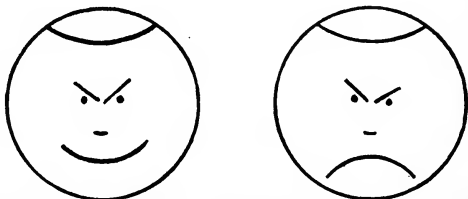

Illustration of the change of expression produced by the muscles of the mouth.

these muscles cause the mouth and eyes to assume a great variety of positions. Even the nose may be moved by muscles, and in rare cases the ears also. The different shapes of the mouth and eyes which these muscles produce are reliable indications of the feelings of the mind.

674. Muscular power. — The power which the muscles use is derived from the oxidation both of food and of their own substance. In their work they use about one fourth of the total heat produced in the body.

A horse can drag about two thirds of its own weight, while an ant can drag 40 times its own weight, and a grasshopper can leap 300 times its own length. In proportion to their size, all insects seem to be far stronger than man. The strength of a muscle depends upon its thick-

ness and not upon its length, yet in animals the muscle must be made many times longer than in insects as well as thicker. Thus the muscles of animals have more weight to lift and do a greater amount of work in proportion to their size. A man's muscle fiber is really the strongest known. An insect made as large as a man would probably be unable to move a limb.

675. Precision of movement. — By means of the muscular sense it is possible to regulate the action of a muscle with great precision. But as the effort put forth is greater, the ability to regulate it is less. So while slow and delicate movements can be made with precision, rapid and powerful motions are less under control. After a muscle has exerted itself to its full capacity, it is unable to perform delicate movements with precision for some time.

676. Alcohol and muscle. — Strong drink in any form diminishes both the strength and the endurance of muscles. Soldiers and athletes are not allowed to use it during periods of great exertion. It also interferes with the precision of movements. Drinkers are not allowed to work at railroading, where quickness and precision of movements are always required. Tobacco also weakens the muscles and lessens their precision of movement.

677. Physical effects of exercise. — When used, most cells of the body take in more nourishment, and increase in size and strength. Muscles, especially, grow larger and stronger by use. Then the digestion, circulation, and respiration all show increased vigor to supply them with extra energy. Thus the whole body grows stronger.

Round shoulders are most often due, not to weakness of the spine, but to weakness and inaction of the muscles of the back. The remedy is not to apply braces, for that only permits the muscles to rest and become weaker, but to make constant efforts to throw the shoulders back and so to increase the strength of the muscles. Military drill makes soldiers erect for this reason.

678. Overwork. — If the muscles turn too much heat of the body to motion and work, there is too little left

to carry on the actions of the internal organs. Then there will be less food prepared for the repair of the cells, and to replenish the fuel for oxidation. So the whole body, including the brain, will remain fatigued. Besides the energy expended by the muscles, the brain also does a large amount of work in sending orders for their work. Probably the nervous system always becomes fatigued before the muscles.

679. Kinds of exercise.— It is a problem for students and clerks to determine how much exercise will rest and stimulate the brain to the greatest degree, and yet take no energy from it. The kind which a person enjoys best is the best exercise for that person. If possible, the exercise should be of a form which will turn one's thoughts completely from the day's work and from the exercise itself. So a useful occupation or some absorbing game is especially valuable as exercise. Dumb bells, chest weights, and all kinds of gymnastic exercises are excellent for developing the muscles. Their only disadvantage is that their use becomes monotonous, and a person must force himself to use them. They have the advantage that they can be exactly regulated to develop any defective part of the body. When done in classes and under an instructor they are especially valuable.

680. Amount of exercise.— A few moments of brisk running or romping will set the blood flowing faster and produce a clearer brain than an hour of slow walking. A person's own feelings should warn him when to stop. Boys and girls need plenty of exercise toward the end of their time of growth. A body well developed by exercise carries its strength through life.

In a school, a position upon either the baseball or football or athletic team often uses the surplus energy which in former years was expended

in midnight hazings, and also develops the traits of bravery, manliness, and self-reliance. There is a special danger of overexertion in competitive sports, but with intelligent oversight of the teachers they are a great benefit to all.

SUMMARY

1. Cells whose use is to produce motion are called *muscle cells*.
2. In the arteries and in most of the organs of the chest and abdomen are spindle-shaped muscle cells, which are not affected by the will, but are controlled by the sympathetic system.
3. Muscles covering the bones and moving the body under the control of the will form one half of the body.
4. Voluntary muscles are made of ribbonlike cells which are marked crosswise.
5. Impulses from motor nerves cause a muscle to become thicker and shorter, so that it moves anything attached to its end.
6. A muscle ends in a stringlike tendon which crosses a joint, and is attached to the lower of the two bones which form the joint.
7. Muscles are arranged in pairs. Those upon the back side of a limb usually straighten the joint, while those upon the front side bend it.
8. Owing to the manner of their attachment, most muscles must put forth far greater force than the weight which they can lift.
9. A piece of a man's muscle is stronger than any other muscle of the same size.
10. The power for contraction of a muscle is derived from the heat of oxidation within the body. About one fourth of the heat is thus used.

11. By exercise of the muscles, the nutrition of the whole body is improved.
12. Too much exercise uses the power which should go to the brain and other organs and so harms the body.
13. That form of exercise is usually best which most interests a person.

DEMONSTRATIONS

165. Skin a chicken's leg and separate each muscle. Show their broad upper attachments and the small tendons into which the lower ends taper. Cut off the skin from the lower parts of the legs and toes and show how the tendons are attached to the toes. Notice that bending the leg tightens the tendons and flexes the toes. Explain how this compels the toes to grasp the perch while the fowl is roosting. Pick a muscle apart to show the separate fibers. Sketch a muscle.

166. Point out the main groups of muscles upon a boy. Have him perform such motions as raising his arm and clenching his fist, and feel what muscles are in action. Notice that when one set of muscles is in action the opposing set also acts so as to steady the limb. Point out the tendons, especially in the wrist and knee.

167. With two needles tear apart a small shred of muscle from a piece of cooked meat and examine it under the microscope with a power of at least 200 diameters. Sketch the ribbonlike muscle cells and their fine cross markings. Notice the small amount of wavy connective tissue between the cells. Examine a prepared specimen to show the cells cut across and the capillaries surrounding the cells.

168. Show involuntary muscle cells by preparing a shred from a fowl's gizzard, as in demonstration 167. Sketch the specimen.

169. Hold a pencil firmly with the elbow flexed. Contract all the muscles of the arm strongly. Notice that the whole arm trembles. Now let the pencil tap the table by means of this trembling motion, and notice that the taps are about ten a second. Explain that the taps are due to successive motor impulses from the brain. Now tap the table rapidly with the ordinary motion of the hand. Notice that it can be done only about five or six times a second. Explain that in this case the mind must cause two separate sets of muscles to contract alternately.

REVIEW TOPICS

1. Show that motion is essential to the process of life.
2. Describe involuntary muscles and tell their use.
3. Describe how voluntary muscles appear to the naked eye and under the microscope.
4. Describe tendons; how they cross the joints; and their attachment to bones.
5. Describe the contraction of a muscle.
6. Describe the three kinds of levers; show how bones and muscles form levers; and give examples of each kind.
7. Describe the arrangement of muscles in opposing sets.
8. Describe the action of muscles at the elbow; at the wrist; at the fingers; at the hip; at the knee; at the ankle; at the toes; in the back; over the abdomen; and upon the face.
9. Show how standing is performed; how walking; and how running.
10. Give the source and amount of muscular power.
11. Show that great exertion impairs the precision of movements.
12. Show that muscle training is really mind training.
13. Show that physical exercise benefits the whole body; and that overwork fatigues the brain.
14. Show what kind of exercise is the best.
15. Show how to regulate the amount of exercise.
16. Give an estimate of the value of competitive sports in schools.

CHAPTER XL

BACTERIA AND DISEASE

681. Dangers to life. — Man's health is often assailed by his inward appetites and desires. He is also exposed to accidents and dangers from without. Formerly men were in constant danger from wild animals, but now man — the noblest and most powerful living being — is constantly assailed and often conquered by the smallest and simplest of living creatures. In the midst of his work he may be stricken with a deadly disease because millions of tiny creatures are poisoning the cells of his body.

The microscope has revealed a world of tiny creatures of an infinite variety of form and manner of life. Three of the simplest forms are *yeast*, *mold*, and *bacteria*. All of them are of importance to man.

682. Yeast is a plant which consists of a single cell scarcely larger than a red blood cell. The cells live upon sugar, and begin a series of changes to return it to the air and water for use as plant food. Were it not for this provision, much plant food might encumber the earth in the form of sugar and starch, and both man and animals might starve. After the sugar upon which yeast cells feed is used up, they remain in a dormant state, and some become dried and pass off as dust. Some are always floating about in the air ready to grow in anything containing sugar. Yeast must have warmth and moisture for its growth. So cold or dried fruit does not sour. Yeast is

used in bread making and in the manufacture of alcohol (see Chapter IV).

683. Molds form a class of plants which may grow in nearly all kinds of moist substances, and there induce a kind of decay. They may usually be recognized by their furry growth on the surface of the affected substance.

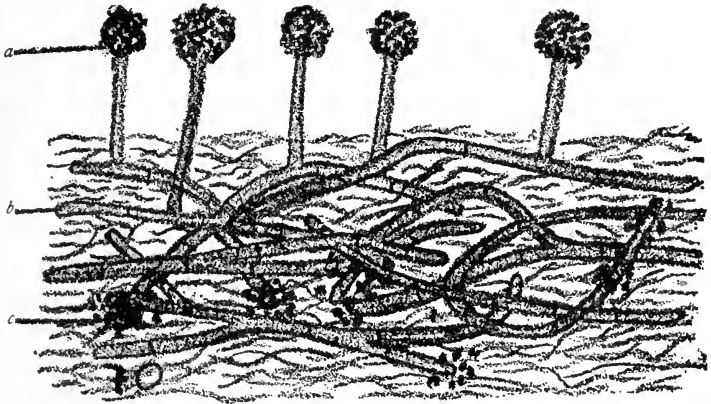

Diagram of mold ($\times 200$).

- a* ball of spores above the surface.
- b* threads beneath the surface.
- c* spores beneath the surface.

The plants themselves are usually a series of threads which burrow beneath the surface. At intervals they send up slender shoots which bear germ cells or *spores*. These shoots constitute the fur which is usually called mold, but many kinds form their spores beneath the surface. The spores are microscopic in size, and can float in the air and grow into mold plants when they fall upon a suitable soil. Most forms grow only on dead material, but a few can grow on living matter. The smut and rust on grain and fruit are plants similar to molds. Ringworm is due to a

mold which grows in the human skin. Mildew and toadstools belong to the same family as molds. In nature molds disintegrate, and return to the soil and air all kinds of dead plant and animal substances, especially hard and resisting tissues like bones, tree trunks, and skins, so that they can again become available as plant food. In warm, humid weather molds grow readily and are often destructive to food and clothing.

684. Bacteria. — The smallest and simplest, as well as the most numerous of living creatures, are round or rod-shaped bodies from $\frac{1}{25000}$ to $\frac{1}{10000}$ of an inch in breadth, and seldom more than $\frac{1}{1500}$ of an inch in length. They are sometimes called *microbes*, but more common names are *bacteria* or *germs*. They are all plants whose mode of growth somewhat resembles the yeasts and molds. Like yeast and mold they, or their spores, are scattered everywhere in the air. When they fall upon moist albumin they grow. A single one can produce over 10,000,000 in the course of twenty-four hours. They often resist influences which would destroy most other forms of life. Even boiling for five minutes fails to destroy the spores of some.

685. Effects of bacteria. — Bacteria destroy the substances in which they grow. Most forms of decay are due to the action of certain varieties of bacteria. They cause dead matter to become soft and melt away, usually with the production of foul-smelling gases and a variety of poisonous ptomaines. In the soil there are forms of bacteria which oxidize all kinds of animal and vegetable albumin as thoroughly as though it were burned. Thus bacteria destroy the dead and waste matter of vegetables and animals and prepare it for vegetable food again. Yeast, mold, and bacteria are indispensable friends of all living beings; and decay is a step in the preparation of our food.

686. Effects of bacteria upon living bodies.—Wherever there is a moist cavity containing albumin, bacteria may grow. The mouth is usually swarming with them, and may be offensive from the decay which they cause. They also grow abundantly in the intestine. A few forms can grow in the lymph spaces within a living body. There they form poisons called *toxins*, which circulate with the blood and produce various diseases, such as erysipelas, diphtheria, typhoid fever, consumption, cholera, lockjaw, and the grippe. Because these diseases are always caused by germs which are planted in the body they

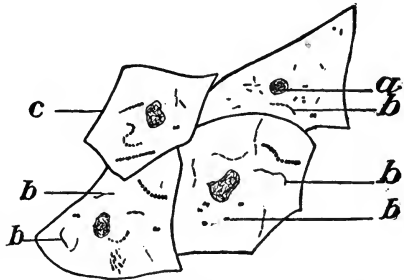

Bacteria growing in the mouth (× 400).

The specimen was obtained by scraping a healthy mouth.

- a* nucleus of an epithelial cell.
- b* different forms of bacteria.
- c* outline of an epithelial cell.

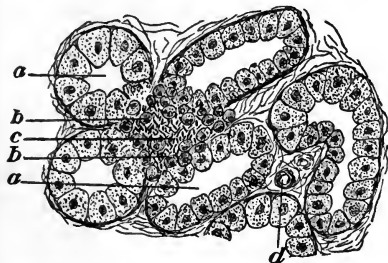

Bacteria growing in a kidney and producing an abscess (× 300).

- a* kidney tube.
- b* white blood cell attacking bacteria.
- c* bacteria.
- d* blood tube of the kidney.

are said to be *infectious*. All diseases caused by germs are infectious.

Measles, scarlet fever, mumps, whooping cough, and smallpox also are due to some influence from without the body. This influence is supposed to proceed from a kind of germ, also. These diseases can be caught by being in the same

room with a sick person, and so are said to be *contagious*.

687. How bacteria enter the body. — Germs of an infectious disease may remain alive outside the body in anything containing animal or vegetable matter. They may grow in damp clothing, or in sinks or wells, or in the soil, and may cause disease in whoever happens to take them into the body. Dirt and filth make good soil for the growth of the germs, and are well-known causes of disease. The germs may become dry and remain in a dormant state for years, and finally produce the disease again.

Bacteria may enter the body wherever the epithelium is gone, and the lymph spaces are bare. Even a scratch or a pin prick may admit thousands at one time. They can also enter through the mucous membrane of the nose or throat, or they may be swallowed in drinking water or licked off from a knife or spoon which another person has used.

688. How the body destroys bacteria. — Germs of disease constantly surround us, and the skin is constantly being scratched and pricked, affording them entrance. Yet only in rare instances do they grow and produce sickness, for the body has three very efficient weapons of defense.

First. *The white blood cells* have a special power of seeking out bacteria and the toxins which they produce, and of enveloping and destroying them (p. 397).

Second. *The plasma of the blood and lymph*, by some chemical power, is able to destroy germs of disease.

Third. The serum of the blood often contains a substance called an *antitoxin*, which destroys the toxins of the germs and so stops their action. When a disease has progressed for a few days or weeks, the antitoxin is formed in sufficient amount to overcome the germs, and so the disease comes to an end.

If the toxins of diphtheria germs grown outside the body are injected into a horse, the plasma of its blood will contain the antitoxin of the disease. If its blood is drawn and allowed to clot, the clear serum will

contain the antitoxin, and if injected into a man suffering with diphtheria, will tend to overcome the germs and to cure the disease.

Cows sometimes have a disease which seems to be a modified form of smallpox. By vaccination, the same disease can be transmitted to a man in whom it causes but slight inconvenience, but yet protects him against smallpox almost as thoroughly as an attack of the disease itself. Universal vaccination has destroyed the terrors of smallpox, so that from being one of the most common and deadly of diseases it is now one of the rarest.

689. Destruction of germs outside the body. — The *sun* is one of the most efficient agents in destroying bacteria of disease. It acts partly by drying the food upon which they live and partly by means of its own chemical power. An abundance of sunshine in a place renders it almost surely free from disease. In some hot and dry climates decay is almost unknown, for bodies become dried before the germs can grow. On the other hand, darkness, decay, and disease go together.

The *wind* drives away the germs. In the open air it is almost impossible to transmit disease. In closed rooms, germs which are given off from a diseased body may collect in great numbers, and in sick rooms may reënter the sick person and so prolong his sickness. Good ventilation is one of the best means of preventing diseases.

The *soil* destroys germs of disease. In it are special germs whose work is to oxidize all organic matter, including other kinds of germs. It also filters out the germs from dirty water which soaks into it. Burial will destroy the disease germs on all kinds of substances and dead bodies.

690. Antiseptics. — Man uses three principal means to destroy disease germs which may threaten him. In the first place, he may wash them away with soap and water. He can thus get rid of most germs.

Secondly. A boiling heat applied for fifteen minutes will kill all kinds of germs. A substance freed from germs is said to be *sterilized* or *disinfected*. Clothes and utensils used in a sick room can be made safe for future use by boiling. Before a surgical operation, the instruments and dressings are thoroughly sterilized by boiling.

Thirdly. A variety of chemical substances called *antiseptics* are poisonous to bacteria and destroy them almost at once. Carbolic acid added to from twenty to one hundred times its weight of water is very efficient in destroying germs which it can touch. Bichloride of mercury added to from one thousand to five thousand times as much water, is also very good, but it destroys iron or tin vessels. Chloride of lime is also much used.

Substances must come into intimate contact with germs in order to kill them. A little carbolic acid or other antiseptic may impart an odor to a room or overcome a smell, but to destroy the germs it must be applied in quantity directly to the germ.

Before a surgical operation the surgeon washes and sterilizes his hands, and covers his clothes with a sterilized gown. He carefully avoids touching any object which has not been sterilized either by heat or by chemicals. Before he operates he scrubs and sterilizes the field of operation just as he did his hands, and then surrounds it with sterilized towels. At the end of the operation he covers the wound with a dressing which has been sterilized by heat or chemicals. Then no germs can enter, and the largest wounds heal in a few days without pain or discharge. The safety of operations now as compared with those of forty years ago lies in the discovery of how to exclude germs of disease.

691. Care of a sick room.—When a person is sick, every effort should be made to exclude germs of sickness. Fresh air and sunshine are always of the utmost importance in a sick room. It will always be better to run the risk of having the room a little cold than to have its air close.

In contagious and infectious diseases, air and sunlight are the chief means of destroying the germs.

Cleanliness should always be enforced in a sick room. The night clothes and bed linen should be changed as often as they are soiled. The whole body should be bathed daily, and the teeth and mouth cleansed.

Talking above all things disturbs a patient. Especially avoid all references to doleful cases of suffering like the patient's. Do not ask

him if he will have this thing or that, but bring it to him without annoying him with the necessity of deciding for you. Anything which disturbs or annoys him uses up some of the strength which he needs in overcoming the germs of disease.

In a contagious disease all visitors should be excluded from the room, and all furniture not absolutely necessary should be removed.

When the disease is at an end, the sick room should be thoroughly scrubbed with an antiseptic. It should be opened to the sunlight and air for several weeks before being used again. Everything possible in the room should be boiled or scrubbed. The patient should receive a thorough bath before leaving the sick room.

692. Blood poisoning. — Disease germs may grow upon any open wound, making it tender and causing it to run matter. In severe forms they cause a swelling of the surrounding parts, producing *erysipelas* or *blood poisoning*. All this can be prevented or overcome by applying clean or antiseptic dressings.

Milk, in summer time, forms a good soil in which germs from the air grow and form acids and other poisons. They produce stomach and intestinal disease in bottle-fed babies. Boiling the milk and bottles destroys the bacteria and prevents the disease.

693. Tuberculosis. — Almost the first disease of which bacteria were proved to be the cause was tuberculosis of the lungs, or consumption. The discovery was made by Robert Koch, a German physician, in 1881. He found that the germs which are always present in the tissues of a consumptive can be grown in a bottle of blood serum, and will multiply to an unlimited extent when small amounts from one bottle are planted in another. He also found that artificially grown bacteria will produce tuberculosis when they are injected into a healthy animal.

Though the cause of consumption was determined before that of most other infectious diseases, yet consumption is among the last of these

diseases to be actively combated. It still causes one tenth of all deaths, and kills more persons than all other infectious diseases combined. Thus in New York State during 1907 there were 147,442 deaths, of which 14,406 were directly due to tuberculosis of the lungs, while all other infectious diseases, including the grippe, caused 10,306 deaths. Either inexcusable ignorance or wilful neglect is responsible for the greater number of these deaths by tuberculosis, for the disease is preventable and in its early stages is usually curable.

694. Nature of tuberculosis. — It is not probable that any person or animal is born with tuberculosis. The disease is caught from tubercle bacteria. Men usually catch it by inhaling bacteria which a consumptive has expectorated on the floor or ground, and which have been dried and blown about as dust; sometimes, however, tuberculosis is caught through milk or meat from an infected animal. The germs may multiply in almost any tissue in which they find lodgment. They cause the growth of white nodules, or tubercles, like pin heads, and do harm in three ways: first, the tubercles destroy the tissues of the infected part; second, the tubercles may break down and form abscesses; and third, the bacteria form poisons which circulate in the blood and poison the whole body. The most common seat of the trouble is the lungs, for the bacteria usually enter the body with the air that is breathed. The bones and joints also are often affected, especially in children.

Usually the first sign given by developing tuberculosis is loss of flesh and strength. Affected bones and joints become sore and swollen. If the lungs are affected, there is a cough with the expectoration of mucus, and there are changes in the breathing sounds. If the temperature of the body is taken at regular intervals, it will be found that there is a fever toward night and after exertion. The continued presence of a slight afternoon fever in a person who has lost strength and weight is suggestive of tuberculosis. While some cases of consumption develop and produce death within a very few weeks, the usual course of the disease

is slow. It usually lasts for years rather than months or weeks. It produces but little pain, and those who suffer with it are usually hopeful of recovery. They may be expected to recover if they take the trouble to follow the proper mode of life.

695. Tendency to consumption.—Tubercle bacteria are very often present in the dust that fills the air in streets and houses. A closed room acts like a trap for dust, and the air in it will have more germs per cubic foot than the air outside. If a person is vigorous and well nourished, and always has fresh air to breathe, his body is not a favorable soil for the growth of tubercle bacteria; but if his muscles are poorly developed and his breathing is restricted from any cause whatever, or if he sleeps in a poorly ventilated room, he is very liable to take the disease. When the breathing is deep and forcible, the bacteria are kept in constant motion and have little chance to lodge and grow. Deep breathing of fresh air also promotes a good circulation, and healthy blood has great power to destroy the few germs that may find lodgment. On the other hand, if the air in any part of the lungs is not changed thoroughly and often, bacteria may remain in the air sacs and smaller bronchi, and multiply there; and if foul air is breathed over and over, the blood is not able to destroy the germs.

Thus it happens that such persons as clerks and students, who sit still a large part of the time and breathe lightly, are much more likely to take consumption than those who, like explorers, hunters, pioneer miners, and many farmers, lead a life of muscular activity in the open air, though they are constantly exposed to inclement weather. And thus it is that men who live and labor all day in pure air often contract consumption from close sleeping rooms when their mode of life otherwise would insure their freedom from almost all forms of infection.

696. Scrofula.—In some children the lymphatic glands under the lower jaw and on the side of the neck are swollen. These children are usually pale and subject to colds and other forms of illness. The swollen glands often break down and produce abscesses. In many cases the children have swollen joints or bones. The trouble is usually called scrofula. In many cases, though by no means always, scrofula is due to the presence of tubercle germs. Scrofulous children are likely to take tuberculosis of the lungs and they should be subjected to the same preventive and curative treatment as though they actually had tuberculosis.

697. Prevention of consumption.—When all tubercle germs are destroyed, consumption will be extinct, and no new cases can arise. The breath of a consumptive does not contain the germs. The bacteria are spread almost exclusively by means of the sputum. They are not likely to escape from the sputum unless it is dried, but the dust from the streets and other places on which consumptives have expectorated contains them in a dormant state, ready to grow when inhaled. Thus the key to the prevention of tuberculosis consists in collecting and destroying the sputum before it dries.

A consumptive should never expectorate on the floor, or on the ground, or on any other place where the sputum may dry. All matter that comes from the nose and mouth should be deposited in cups or flasks which should be burned, or on clean handkerchiefs which should be kept in a special pocket or other place and boiled before they are washed. Sputum cups may be purchased cheaply at drug stores.

In coughing and sneezing, consumptives should hold a handkerchief to the mouth to avoid unconsciously expelling mucus. They should keep the hands and face free from dried sputum. A consumptive man should not wear a beard on account of its likelihood to be soiled. A consumptive's room should face the sun, and the curtains should be drawn aside and the windows kept open to the air. Any other detail which would promote the destruction of the bacteria should be observed.

698. Curing consumption.— In order to recover, consumptives should be specially careful of the disposal of their sputum, since by that means they avoid reinfesting themselves with the bacteria. They should breathe pure air at all times, day and night. The windows of the sleeping rooms should be kept wide open. It is still better to sleep in the open air, in tents or on roofs or piazzas. By using a form of window tent a patient can sleep with his head in an open window while his body remains in the warm room.

There is a groundless fear that cold air and the wind are bad for consump-

tives. This is not true. Patients should be warmly clothed and be protected from the rain and from direct drafts which cool the body unequally. Experience proves that they do not take cold when observing these two precautions.

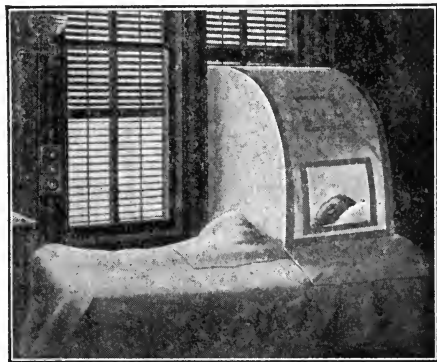

Window tent.

A consumptive can be cared for as efficiently, as comfortably, and as cheaply in his own home as in any other place. The air of high mountains is of value mainly because its rarity compels deep breathing.

Consumptives need an abundance of nourishing food. Meat, eggs, milk, and fish should form a large part of the diet, because of their high nutritive value and their ease of digestion. Consumptives should avoid everything that interferes with their digestion. In all other things they should lead a simple, quiet life according to well-known rules of hygiene.

By these means a large proportion of cases may be cured. It is well

for consumptives to go to a sanitarium for a short time, in order to receive instruction how to eat, sleep, and manage their mode of life.

SUMMARY

1. Yeast is composed of living plants which begin the work of returning sugar back to its original elements.
2. Mold is composed of tiny rodlike plants which grow through animal and vegetable tissues and destroy their albumin.
3. Bacteria are the smallest living beings. They cause decay and change albumin back to its elements in the air and soil.
4. Bacteria may produce virulent poisons.
5. A few kinds of bacteria grow in the body and there produce various forms of disease, some of which can be transmitted to other persons.
6. The body is protected against the bacteria of disease by the white blood cells, by the plasma, and by substances produced in the blood.
7. Outside of the body, sunlight, fresh air, running water, and the soil destroy disease germs.
8. Man destroys disease germs by washing them away, by boiling objects containing them, and by poisoning them with such substances as carbolic acid and bichloride of mercury.
9. Sunlight, fresh air, and cleanliness are essentials in every sick room, and especially in infectious diseases.
10. After an infectious disease, the room and all its contents should be scrubbed, and aired for a month.
11. Consumption, or tuberculosis, is an infectious disease, spread mainly by means of dried sputum.
12. Fresh air day and night, and good food, are essential in the prevention and cure of consumption.

DEMONSTRATIONS

170. Place a little yeast upon a microscope slide and examine it with a power of at least 200 diameters. Notice the oval cells from which smaller cells are budding.

171. Take a bit of mold from cheese or bread and examine it with a power of at least 200 diameters. Notice the strings of mold which appear like very small jointed rods. Notice the collections of round spores at the tops of the projecting stalks.

172. Place a little hay in a bottle of water and set it in the sun. After a few days, place a drop of the water upon a glass slide and examine it with a power of at least 400 diameters. Notice that numerous bodies of various sizes and shapes are swimming in the drop. These are the *animalculæ* which older books describe. Notice also the real bacteria which appear as the finest kinds of dots and short lines. Most of them are in constant motion. Only a few kinds of bacteria can be recognized by their appearance.

173. Prepare some gelatine as if for the table, and pour some while hot into a tightly covered dish which has been boiled. Take off the cover for a moment before the class, and, replacing it, set the dish aside for a few days. Then a few specks of mold or of scum will appear upon the surface, each showing where a germ has fallen from the air and multiplied to form the spot. Explain that bacteria are studied in laboratories in much the same way.

174. Have a druggist prepare a solution of carbolic acid 1 to 100, and of bichloride of mercury 1 to 1000. Show the class how they should be used in washing the hands and clothes. Also show the pure drugs, and warn the class against using them in this form. Show also chloride of lime and other common antiseptics.

REVIEW TOPICS

1. Describe yeast and give its uses in nature.
2. Describe mold and give its uses.
3. Describe bacteria and their relation to decay.
4. Give the uses of decay.
5. Show how bacteria can enter the body and how they produce sickness.

6. Show how bacteria are destroyed in the body by white blood cells and by the blood plasma.
7. Describe an *antitoxin* and tell how it is used in treating diphtheria.
8. Describe vaccination.
9. Show how bacteria are destroyed by sunlight; by the air; by running water; and by the soil.
10. Show how man destroys bacteria by cleanliness; by heat; and by antiseptics.
11. Show how a surgeon destroys germs before and after a surgical operation.
12. Give some hints about the care of a sick room; and about cleansing it after an infectious disease.
13. What is the cause of consumption?
14. How is consumption usually caught?
15. What are the signs of a developing case of consumption?
16. What precautions should a consumptive take in order to avoid infecting other persons?
17. What should a consumptive do in order to recover?

NOTE. — For a more extended discussion of bacteria and disease, see "The Story of the Bacteria," by T. Mitchell Prudden, M.D.

CHAPTER XLI

REPAIR OF INJURIES

699. Injuries. — Many causes outside the body operate upon its cells to injure them. Excessive heat or cold may impair their vitality or cause their death. A sudden change from heat to cold is a common cause of injury. Blows and cuts may kill whole armies of cells. Above all, bacteria may cause injury and disease. In a few hours, the injured part shows a change, which is apparently due to an increase of the injury, but which is really caused by nature's attempt to repair the part.

700. Congestion. — After an injury has been received the first step in its repair is to dilate the arteries so as to permit more blood to flow through the part. Then more plasma will penetrate into the lymph spaces. This produces redness and some swelling and is called *congestion*. Congestion is a sign of attempted repair. This alone may be sufficient to heal the injured part.

701. Inflammation. — If the injury is greater, there is a change in the behavior of the white blood cells. Ordinarily they tend to flow more in the outer part of the blood stream, but when the arteries enlarge as a result of injury they adhere to the sides of the smallest blood tubes and some pass entirely through their walls and lodge in the lymph spaces. There they envelop and digest the injured parts and carry them away with the lymph. The lymph and blood cells have great power of absorbing blood and

dead cells, or even such substances as stitches left in the body by a surgeon. The excess of white blood cells causes more swelling, and some pain. This is an aggravated form of congestion, and is called *inflammation*. Some of the white

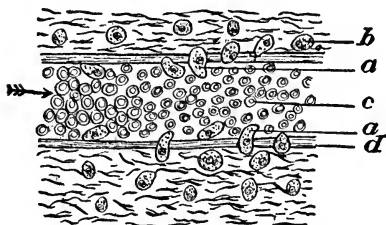

Beginning of inflammation ($\times 400$).

- a* white blood cells adhering to the wall of a capillary and passing through it.
- b* white blood cells which have passed outside of the capillary in order to repair an injury.
- c* red blood cells passing through the capillary.
- d* wall of capillary.

blood cells grow in place of the removed cells and so fill in the gap. Each cell becomes long and branched and finally develops into a connective tissue cell. If the new cells are in great amount, they have a different appearance from the original cells and are then called a *scar*.

702. Repair of cuts.—

When a cut is made in a tissue, the same process takes place, but in addition new blood tubes sprout from each side of the wound and interlace in the middle. The white blood cells grow about the new tubes and become connective tissue and so bind the edges of the cut together.

When the skin is injured, the white blood cells form new tissue upon the surface while the epithelium spreads over it from the edges, stopping the growth and completing the healing process. Sometimes the new connective tissue grows faster than the epithelium and forms soft tufts, which project above the healthy flesh. These tufts are called *proud flesh*. If they are scraped off, or cauterized, the epithelium is enabled to cover the wound, and to complete the healing.

703. Injuries due to bacteria. — If bacteria cause the injury to the cells or if they enter and grow after the injury is done, the blood cells must fight them as well as repair the damage. Sometimes they cannot do both at once. Then the white blood cells and plasma leave the blood tubes to a still greater degree and lay siege to the bacteria until they completely fill the lymph spaces. They even stop up the blood tubes, producing great swelling and pain. White blood cells and bacteria are now tightly wedged among the injured tissues with no chance for escape and with no nourishment. Then the whole injured part becomes soft and finally bursts and runs out as a creamy matter called *pus*.

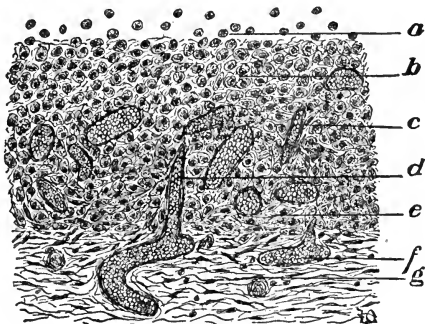

The repair of a wound ($\times 200$).

- a* new white blood cells upon the surface of a raw spot.
- b* growing white blood cells.
- c* new capillary.
- d* new branch from a capillary.
- e* older white blood cells which are becoming elongated and branched like connective tissue cells.
- f* old capillary sending out a new branch.
- g* old connective tissue.

Thus nature sacrifices a part of the body in order to get rid of the bacteria which threaten to overcome the whole body. Then the white blood cells grow and repair the wound as in clean wounds. A mass of pus in the body is called an *abscess*. Every abscess or collection of pus is caused by bacteria.

If bacteria grow upon an open cut, the white blood cells must devote part of their energies to fighting them, and so healing goes on slowly,

while the dead cells, or pus and plasma, run off in a continuous stream. So bacteria hinder the repair of wounds, and prevent their edges from growing together directly. Then the cut must slowly heal from its bottom. When a wound begins to be tender and to discharge, it is said that one has *taken cold* in it. Taking cold in a wound means that bacteria are growing in it. Their toxins may poison the whole body and produce a severe fever, which may cause death. Surgeons now exclude bacteria from the wounds which they make. The white blood cells then have nothing to do but repair the cut, and every part of the wound heals at once. Healing applications do good mainly by destroying germs which may come near the wound.

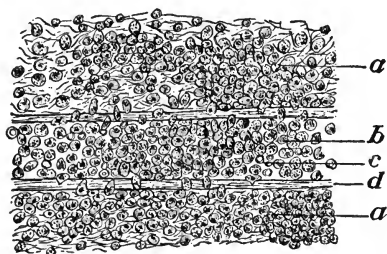

The second stage of inflammation ($\times 200$).

- a* white blood cells which have left the capillary.
- b* white blood cells which nearly block the capillary.
- c* a few red blood cells which still circulate.
- d* wall of the capillary.

may be prevented by covering fresh wounds with clean dressings.

When an abscess is forming, the heat of a poultice dilates the blood vessels, and so hastens the softening process. Thus it "brings the abscess to a head" and hastens the discharge of the pus. Since the pus will form anyhow, it is always better to open the abscess and let out the matter at once. This can be done without pain by using cocaine.

705. Taking cold upon the lungs.—When a mucous membrane is injured, as by exposure to cold, there will be the same changes in its blood tubes as in a wound

704. Treatment of inflamed wounds.—A tender discharging wound should be cleaned with boiled water, and covered with a clean antiseptic dressing, to soak up the discharges and bacteria. The dressings should be changed as soon as they become full of matter. Inflammation

of the flesh. Then the membrane will be red and tender and possibly swollen. Owing to the thinness of the membrane and of its epithelium, the plasma and white blood cells will come to the surface. The matter may collect until it is coughed up and expelled. The nose and throat are the most often affected, but in severe cases it extends to the trachea and lungs. When the matter fills the air sacs of a part of the lung, the disease is called *pneumonia*.

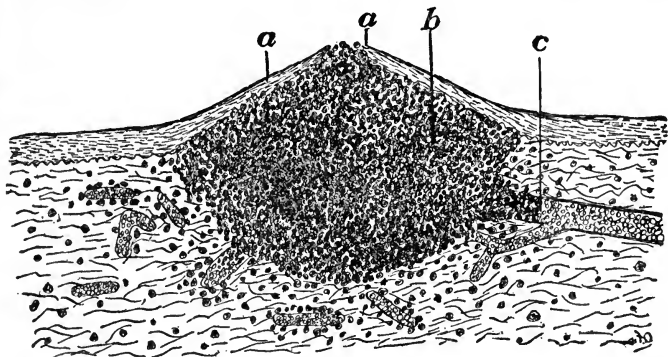

The third stage of inflammation, or the formation of an abscess ($\times 50$).

- a* epithelium of the skin softened and bursting.
- b* white blood cells which have packed the tissues full and shut out nourishment.
- c* blood tube stopped by white blood cells.

In order to take cold there must be an injury to the cells, and bacteria must grow upon the injured spot. It often happens that the cells are exposed to injury, and no cold is contracted, for germs do not happen to grow, while on the other hand the exposure may be slight, and yet may enable germs to produce a severe cold.

In colds and in an abscess, the pus and discharged substances are not foul matters which have been circulating in the blood, but consist of the strong blood cells which have died fighting for the defense of the body, and of plasma, which is an efficient protection against the germs. Both being dead and charged with the toxins of the bacteria, they are no longer of use, but should be expelled from the body.

When a cold is first coming on, a hot bath and hot drinks and hot bed clothing, together with a liver stimulant, may cause the skin and liver to excrete enough toxins to enable the white blood cells to overcome the bacteria.

706. A long life. — Although in former times man was often conquered by bacteria of disease and even now is continually assailed, yet now he knows more about his tiny foes and is able to protect himself. He knows that his eating, his breathing, his work, his rest, and in fact his every action will render his cells either more or less able to combat with disease germs. If all men would live up to their knowledge, germs of disease would find no lodgment in the body, while there would be no cause of disease in the body itself. Then man's mind would remain with his body far beyond the allotted three score and ten years, and, during all its long stay, would find the body a willing servant to build the ideal plans of the spirit into enduring realities.

SUMMARY

1. An injury to the cells of the body causes the arteries to dilate and bring more blood to the part.
2. Over a sore spot the white blood cells form new connective tissue while the epithelium of the healthy skin spreads over the new tissue, stopping its growth and completing the healing process.
3. When bacteria are growing in an injured spot, the white blood cells attack them, but are often killed themselves and pass off as creamy matter called *pus*.
4. If the white blood cells cannot overcome the bacteria, they hem them in until they and the tissues starve and run out as *pus*.

5. The changes which take place about an injured part cause it to become red, painful, swollen, and warmer than usual.
6. If wounds and all other injuries were protected against bacteria, they would heal at once without discharging pus or other matter.
7. In injuries to mucous membranes, the white blood cells and plasma pass through the thin tissues to the surface and are discharged at once.
8. Taking cold means an injury due to bacteria.
9. The matter discharged from an abscess or from a "cold" is composed of the best cells of the body which have died in its defense.

DEMONSTRATIONS

175. Scratch the skin upon the lower part of the arm. Notice that a red line develops in a moment. Explain that the scratch injured the cells and partly paralyzed the blood vessels, and that the redness is due to more blood in the part, which has come to repair the damage and to protect the rest of the body.

176. A pimple upon the face will illustrate the different stages of inflammation. Explain that a pimple may be caused by a prick too small to be noticed, but which has introduced some bacteria beneath the skin. Explain that the redness is due to the blood which has come to repair the damage. Explain that the white spot upon the top of the pimple is the softened area through which bacteria and dead cells will finally pass out, and that the pus is composed of white blood cells which have died fighting to protect the body against the bacteria.

177. Place a tiny drop of matter pressed from a pimple or a cut or a scratch upon a microscope slide and examine it with a power of 400 diameters. Notice that it is composed of white blood cells, containing nuclei. Examine also a drop of mucus from the nose and notice that it consists largely of the same kind of cells.

178. Obtain a prepared microscopic specimen from a wound in the process of healing. Show that the newly formed tissue consists of

round blood cells upon its surface, and that in the deeper layers the cells grow larger and become branched. Explain that the deeper layers are the older and that their cells are white blood cells which are growing to become connective tissue.

REVIEW TOPICS

1. Explain in order what happens in an injured part of the body, describing the increased flow of blood, and the action of the white blood cells.
2. Explain the healing of a cut.
3. Explain how a raw spot of skin becomes healed, and what part the epithelium takes in the process.
4. Explain how bacteria in an injured part retard healing.
5. Explain how white blood cells overcome the bacteria.
6. Explain the formation of an *abscess*.
7. Explain taking cold in a wound, and in a mucous membrane.
8. Give the signs of inflammation and its use.
9. Tell what composes the matter discharged from an abscess and from the nose and throat during a cold.
10. Show how to treat a wound in which one has taken cold.
11. Explain how to treat a cold of the air passages.

CHAPTER XLII

PUBLIC HYGIENE AND SANITATION

707. Boards of Health. — In every community a Board of Health is established to have the oversight and control of matters in which the property or acts of one person may affect the health of others. For example, the Board has jurisdiction over sewage, water supply, contagious diseases, obnoxious trades, and nuisances. In many cases its duties are strictly defined by law, but in others, such as serious epidemics of contagious diseases, its powers are almost unlimited.

A Health Board consists of a number of persons who are appointed according to the laws of the several states. Usually each township or county and each village and city has a local board, and over the local boards is some central authority. Each local board makes its own rules in accordance with the general laws of the state. Usually a physician is appointed by the local board as health officer, and has direct control over the enforcement of the health regulations. He investigates complaints about any property or person alleged to be injuring the health of the neighbors, and causes any unsanitary conditions to be remedied. The health officer is a teacher who instructs the public in the elements of modern sanitation and requires his instructions to be carried out. Owing to the strictness and efficiency of the inspections of the various boards and to the educational value of their work, contagious diseases and offensive nuisances are now becoming rare.

708. Garbage. — A subject that often comes before a health officer is the disposal of household garbage and slops. In large cities the garbage is collected by the city

and sorted, and a large share of the cost of its removal is met by the sale of useful material which is recovered. In thinly settled places all household waste is often thrown on an ash heap behind the most convenient outbuilding, producing an offensive accumulation which might become dangerous if material from a case of infectious disease were mixed with it. A garbage pile usually becomes offensive and a menace to health from one or more of three causes.

First, water in any form keeps the mass wet and in a decaying state. Liquid slops and waste containing offensive matter should never be poured upon it. Dry garbage is seldom unhealthful. That which cannot be utilized or destroyed should be kept dry and its combustible parts burned.

Second, bones and other table scraps and kitchen refuse decay and furnish a soil in which bacteria of disease may survive and possibly grow. Most of these substances might be used as food for poultry or as garden fertilizer.

Third, dirty tin cans containing rain water are offensive and become breeding places for flies and mosquitoes. Cans which are clean and dry are useful and salable.

709. Sewage disposal. — Ordinary household sewage is over ninety-nine and one half per cent water, and is in a state of offensive putrefaction. Its proper disposal is necessary, for it often contains disease germs. In an ordinary family which has no bath room or running water, each person uses only a pail or two of water daily. The resulting sewage is almost entirely kitchen waste and wash water, and may safely be thrown upon the ground if the soil soaks it up at once. If there is a bath room and running water, each person is likely to use at least twenty gallons of water daily. The drain pipes should lead the waste water either into a cesspool or into a sewer (pp. 137, 253).

710. The cesspool. — A cesspool is a hole in the ground for receiving sewage and, usually, for allowing it to soak into the soil. A double cesspool is of advantage, so arranged that solid matters will remain in the first cesspool, and only liquids pass into the second. In a properly acting cesspool there are a few inches of sediment in the bottom and a layer of floating solids, neither of which increases in quantity, for decay takes place and destroys and liquefies the solid matter in much the same manner as though it were buried in the soil.

Chloride of lime and other antiseptics used in the bath room hinder the process of decay, and cause the cesspool to become stopped up with solid matter. In a sandy soil a pair of cesspools, each seven feet in diameter and seven feet deep, should dispose of at least two hundred gallons of sewage daily, or as much as a large family produces. Cesspools work well in sandy soil where there is an abundance of room and no danger of contaminating the water supply.

711. A sewer system. — In the simplest and oldest sewer systems the untreated sewage is emptied into the nearest body of water. In order that sewage may not be detected by the senses, it must be mixed with an amount of flowing water at least two hundred times as great as its own volume. But the river which receives the sewage is made unfit for use as a source of water or of ice supply, even when the dilution is far greater. In order that sewage may not be a menace to public health, it must usually undergo treatment at a disposal plant.

An old form of sewage disposal is treatment with chemicals; but this is costly, and the final disposition of the solids formed by the chemicals is often difficult.

Another old plan is to maintain a public farm on which the sewage supplies both irrigation and fertilizer. One acre of sandy land will soak up the untreated sewage of

one thousand people continuously and in safety without needing attention except the occasional removal of the accumulated solid matter. This method is still used with success by some large European cities.

A modern plan is to provide a water-tight cesspool or septic tank in which the solid matter rots away, leaving only liquid to flow out upon the land. Where this method is used, an acre of land can soak up the sewage of several thousand people without the accumulation of offensive solid matter.

A septic tank should be large enough to contain at least as much sewage as the town produces in a day. In the course of the twenty-four hours which it takes a given specimen of sewage to pass through the tank, it undergoes decay by which over half of its solid matter is liquefied; the larger particles fall to the bottom or float on the surface, and remain in the tank till they are liquefied also. The bacteria which produce the greater part of the decomposition, especially of the fats, flourish only in the absence of air; and this condition is secured by the thick scum which accumulates in the tank. As the sewage flows out of the tank, it is made to absorb oxygen in some manner, as by letting it fall in small jets or thin sheets through the air, or by making it flow over a bed of broken stone. Then it is usually allowed to soak into the soil of large sandy beds set aside for the purpose. In the soil the remaining decaying matters are oxidized to harmless products by bacteria which flourish in an abundance of oxygen.

This system closely imitates nature's method of returning decomposing substances to the soil, and is one of the simplest and cheapest of all systems for the disposal of domestic sewage. In a septic tank that is working properly no solid matter accumulates, but the system does not work well if the sewage contains much chemical or factory waste, as such substances prevent the bacteria from flourishing and destroying the solid matter. Street drainage should not be mixed with the sewage.

712. Water supply. — An open well is not a safe source of drinking water, for under the best conditions germ-laden dust and dirt blow into it. In a thickly settled village or city sewage cannot be prevented from filtering into wells,

and all wells should be filled up. A driven pipe is much safer than a large, open well. Its point should be driven at least twenty feet below the water level, and there should be no cesspools or barnyards near it.

Usually water for a city is derived from an outside source and is distributed by means of underground pipes. River water is often used, but most rivers are infected by sewage from other towns or from houses or camps along its banks. The drainage from the excretions of a typhoid fever case, reaching a river, has caused epidemics of typhoid fever in other places in which the river was the source of the water supply.

713. Purification of water.—River water should be purified before it is used. The simplest method of purification is to store the water in a reservoir and allow the bacteria and other solid particles to settle to the bottom. This does not remove all the bacteria, though it greatly improves the water; but reservoir water may be almost completely freed from bacteria and other solid substances by means of good filter beds.

The ordinary filters used in houses have little effect except to remove very large particles of dirt. For efficient filtration water must pass through the filter slowly and under little pressure. Filter beds for the purification of city water consist of underground beds of clean sand about four feet deep. A new bed does not work properly, for the spaces between the particles of sand allow the bacteria to pass through. In the course of a few days, however, a kind of vegetable organism resembling mold grows in the upper layer of sand and covers the sand grains with a gelatinous coating. This coating entangles about ninety-nine per cent of the solid matters which may be floating in the water, and allows only clear water to pass through.

A filter bed an acre in extent will purify about three million gallons of water daily. If a small quantity of alum is added to the reservoir water, a soft, flaky substance is formed which becomes entangled in the

sand and holds back the impurities just as the vegetable growth does. By this method one hundred and twenty million gallons of water per acre can be purified daily.

714. Street cleaning.— In thickly settled places dirt from the streets is often a menace to health, for it contains many kinds of bacteria which cause sickness in men and animals. In wet weather the dirt forms mud which may be carried into houses on shoes and clothing, while in dry weather the germ-filled dirt is blown into our houses in the form of dust. Among the bacteria which are often found in street cleanings are the germs of tuberculosis, lockjaw, and grippe. It is necessary that the streets be kept clean as much on account of the health of the people as for the sake of good appearances. Each community may properly spend large sums of money for street cleaning.

715. Quarantine.— The laws of the various states require physicians to report to the Health Board all cases of infectious or contagious diseases with which they come in contact. The health officer visits the sick person's house and requires all persons living there to conform to all necessary requirements in order to prevent other persons from catching the disease. Smallpox, diphtheria, and scarlet fever may be caught by inhaling the air from the sick room. So in cases of these diseases only the physician and nurses are allowed to enter the sick room; all other persons are required either to leave the premises, or to live in a part of the house remote from the sick person. This enforced isolation is called *quarantine*.

Cases of measles, German measles, whooping cough, chicken pox, and mumps should also be quarantined, but they usually are not, — mainly because of the popular belief that they are not dangerous diseases. Yet in New York state during 1907 measles caused nearly as many

deaths as scarlet fever. Every effort should be made to prevent children from taking any of these diseases.

Influenza, or the grippe, is a contagious disease, and it is probable that ordinary cases of "cold" and sore throat are also mildly contagious. Persons with colds should keep alone as much as possible, and while in the house they should remain in a well-ventilated room. In cases of typhoid fever and consumption the sick persons may usually be allowed to associate with other persons if all discharges from the sick persons' bodies are destroyed.

716. Fumigation and disinfection. — After every case of contagious or infectious disease all infected rooms and articles should be freed from bacteria. The best method of getting rid of bacteria is by scrubbing, washing, and airing, as is done in a thorough housecleaning. To the wash water that is used in the room some antiseptic should be added, such as a tablespoonful of formalin to each quart of water. In addition to the cleaning it is well to fumigate the house with some antiseptic gas. Fumigating candles of sulphur or formaldehyde may be bought at drug stores. In order to do any good a large quantity of the fumigating material should be used while the room is damp, and with all doors and windows tightly closed. Fumigation which does not kill the flies in the room is of no value in killing bacteria, no matter how bad the gas may smell.

717. House flies. — A common carrier of disease is the house fly. Alighting on diseased persons and infected excretions, they carry bacteria on their legs and bodies and infect persons and food on which they next alight. They may carry diphtheria and typhoid fever to well persons and may cause babies to have intestinal troubles. In all cases of infectious disease flies should be kept out of the room and away from all excretions that come from the sick persons.

House flies hatch from eggs which are laid in decaying substances, especially in stable manure. The young flies are white and worm-like, and are called maggots. In about a week they change to brown,

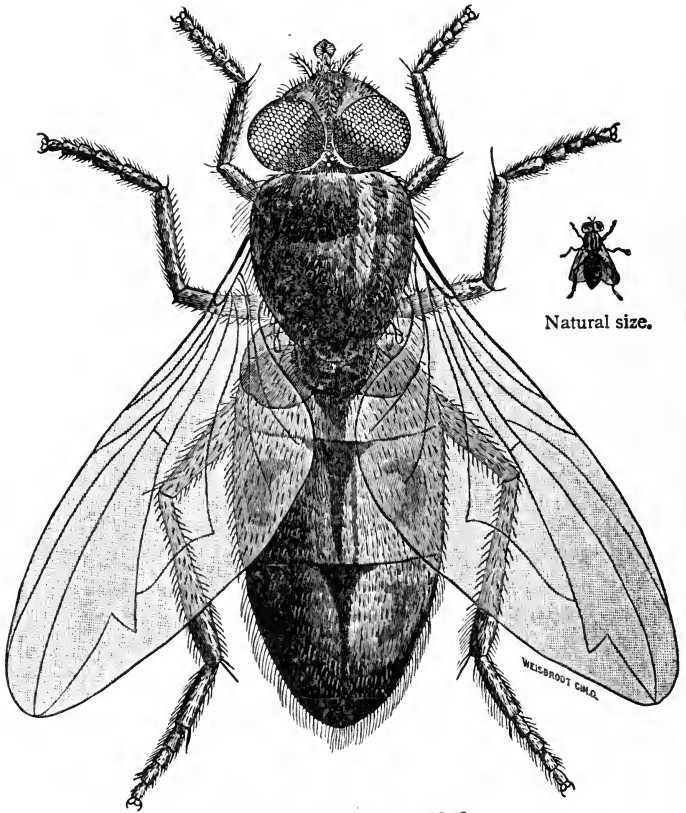

House fly, greatly magnified.

Showing its hairy body and legs, to which filth and bacteria may adhere.

hard-shelled pupas, from which full-grown flies emerge in about another week. There could be no house flies if there were no manure piles, garbage heaps, or other collections of decaying substances in which the young flies could grow. Stables and barnyards should be kept dry and clean, and no collections of decaying substances of any kind should be allowed to exist. Then we should be free from flies in summer as well as in winter.

718. Mosquitoes. — Mosquitoes are the carriers of malaria and yellow fever. These diseases are due to germs which must pass a part of their life in the body of a mosquito and part in the body of a man, and their prevention depends upon the extermination of mosquitoes. The extermination may be effected by drying up all stagnant bodies of water in which mosquitoes breed. Marshy land should be drained dry, or its pools should be converted into running streams. Barrels, pails, and cans of rain water and waste water should be emptied. A little kerosene or other oil poured on the water will kill the young mosquitoes. Persons sick with malaria or with yellow fever should be protected with screens of mosquito netting so that no mosquitoes may become infected by them. By such means as these directed against mosquitoes, tropical countries like Panama have been almost freed from malaria and yellow fever.

719. Pure food laws. — Food that is exposed for sale in open booths and in front of stores may become infected through dirt and dust blown upon it, and from unclean persons handling it, and from flies which alight upon it. Much food is adulterated, often with harmful substances. Food that is kept too long may become spoiled and unfit for use, and so antiseptics are often added to prevent decomposition. Chickens that have been kept on ice for days and weeks without cleaning are poisonous and unfit for use. Until calves, lambs, and pigs are at least a month old they are unfit to be killed for use as food. Milk that is produced under unclean conditions, or that has not been kept cool during its transportation, may become filled with bacteria and unfit for use before it actually tastes sour. In these and other matters pertaining to the purity or freshness of food offered for public sale, Boards of Health are given great power of enforcing laws designed to prevent abuses.

SUMMARY

- I. Boards of Health have control over matters affecting the public health.

2. Garbage should be kept dry and not allowed to accumulate in heaps.
3. In a cesspool the solid matter in household sewage liquefies and decays, and its liquid parts soak into the soil.
4. A septic tank is practically a water-tight cesspool.
5. An effective method for the disposal of city sewage is to run it through a septic tank, then through an oxygenating device, and then upon the surface of plots of ground set aside for the purpose.
6. An efficient method of purifying the water supply of a city is to have it stand in a reservoir and then filter it through sand beds.
7. Dust and dirt on a street contain bacteria of many diseases.
8. Every case of contagious disease should be isolated from the rest of the community, and after the recovery of the sick person the sick room should be cleaned and fumigated.
9. House flies are disease carriers. Their breeding places are wet manure piles and garbage heaps.
10. Mosquitoes cause malaria and yellow fever. Their breeding place is stagnant water.
11. Boards of Health should enforce a high standard of purity and freshness in food that is offered for sale.

DEMONSTRATIONS

179. Procure the rules and regulations of the local Board of Health, and call the attention of the class to their important features. Many of the state and city Boards of Health issue, for free distribution, circulars on contagious diseases and disinfection.

180. Have the class visit any water works and sewage disposal works which may be in the vicinity of the school. Notice the cleanliness of

the streets, and the condition of fruit and vegetables which are exposed for sale in front of stores, and on the streets of the town.

181. In manure piles and garbage heaps look for maggots and pupa cases of house flies. Call attention to the ease with which flies might be exterminated if the whole community would coöperate.

182. Notice the rain barrels about town, and see if they contain "wrigglers," or young mosquitoes. Find out if there is malaria in town, and if so look for the breeding places of the mosquitoes that cause it and plan the means for its prevention.

REVIEW TOPICS

1. Name some duties of a Board of Health.
2. Describe a good method for the disposal of garbage.
3. In what manner is garbage detrimental to health?
4. In a cesspool what becomes of the solid part of sewage? What becomes of the liquid part?
5. In a septic tank what becomes of the solid part of sewage? What becomes of the liquid part?
6. Describe a form of sewage disposal plant.
7. Why is a driven pipe a safer source of water supply than an open well?
8. Describe a method of filtering river water that is to be used as the water supply of a city.
9. What is meant by quarantine?
10. In what way are house flies detrimental to health?
11. How may we get rid of house flies?
12. What diseases do mosquitoes cause? How may we get rid of mosquitoes?
13. What powers have Boards of Health regarding the purity and freshness of foods that are offered for sale?

CHAPTER XLIII

INFECTIOUS DISEASES

720. Resistance to infectious diseases. — All infectious and contagious diseases are caused by living germs (p. 385). Our body always has some power of protecting itself against disease germs, for the white blood cells and the blood plasma attack them. If the body is injured in any way, the germs may succeed in growing. Then the body produces great numbers of new white blood cells, and also develops anti-toxins against the poisons of the disease (p. 386). Thus, as a disease develops, the body usually increases its powers of resistance, and so most cases of infectious diseases end in recovery. The white blood cells finally overcome the disease germs, the liver, skin, and kidneys throw off the poisons of the disease, and thus the disease ends (p. 248).

Often the power of resisting and overcoming the germs of a disease lasts for the rest of a lifetime. Thus a person seldom has smallpox or scarlet fever or measles twice. In some other diseases, as in diphtheria, the resistance lasts for only a few weeks or months. If a person's body can prevent the germs of a disease from growing, that person is said to be *immune* to that disease.

721. Immunity. — A few persons are born with such a high resistance to diseases that they escape measles, scarlet fever, whooping cough, and other common diseases, although they may be exposed to them. Other persons have such a low resistance to diseases that they readily take diseases to which they may be exposed. Those who have adenoids

or large tonsils are likely to take diseases easily, for disease germs grow readily in these tissues (p. 193). Our powers of resisting infectious diseases are lessened by intemperance, overwork, improper food, or by anything else which weakens the body. Our resistance to diseases can be increased by good food, fresh air, exercise, and by anything else which promotes the strength and vigor of the body.

722. Vaccines. — The body can be made immune to many diseases. One way of producing the immunity is by growing the disease germs outside of the body and then killing the germs and injecting them into the flesh. The small quantities of toxins that are used do not produce even a slight sickness, and yet they rouse the body to resist the disease just as if the person really had it. In vaccination against smallpox the living germs of cowpox are used. The vaccines against smallpox, erysipelas, and a few other diseases can be bought at drug stores. We can also buy the antitoxins against diphtheria, lockjaw, snake poison, and a few other diseases (p. 386).

723. How disease germs leave the body. — Few disease germs can penetrate a healthy skin, either to enter or to leave the body. So the skin has little to do with the spread of diseases, except those in which the skin itself is affected.

The most virulent forms of disease germs are given off from the body in the discharges of the intestine and kidneys. In the days when all sewage was simply thrown out of windows and doors every yard and street contained great accumulations of filth, from which epidemics and pestilences were widely spread. The present rarity of severe forms of epidemics is due largely to the cleanliness of our houses and yards, and to proper sewage disposal. Yet a great deal still remains to be done. Thus, in every year improper sewage disposal still causes two or three cases of typhoid fever among every thousand inhabitants of the United States. The disposal of sewage is one of the most important branches of government work (pp. 406-408).

The saliva and the mucus from the nose contain the germs in most infectious diseases. In ordinary breathing we do not expel the germs from the nose and mouth, but in talking and sneezing and coughing we often expel tiny drops of liquid which may be full of disease germs. These drops may dry in a moment, and then the germs may float in the air as dust. The result is the same as if we had breathed the germs directly into the air. Thus foul and dusty air usually contains disease germs. Most infectious diseases are now spread by means of the discharges from the nose and throat, for these two organs are in use during every moment of our lives, while we can easily control the other means by which germs leave the body.

724. Means of spreading disease germs. — Disease germs are likely to be found on anything that has been soiled by the discharges from the body. Dust and dirt containing

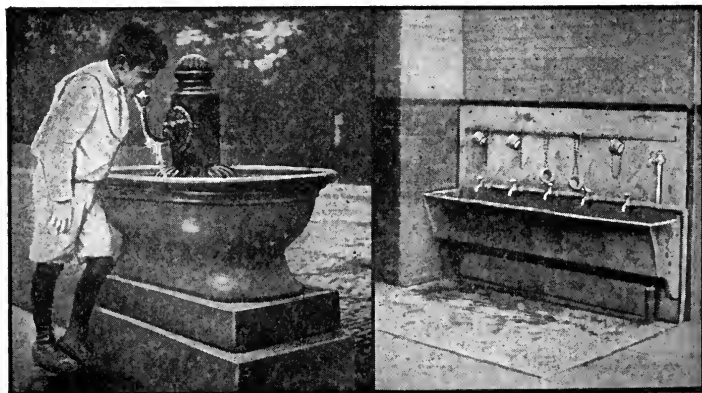

A safe form of public drinking fountain.

An unsafe drinking place in a public school.

the germs settle on our floors and carpets. Everything on which saliva falls may contain the germs. The habit of spitting spreads millions of germs. Soiled dishes, handkerchiefs, towels, bedclothing, and underwear are all likely to

be covered with germs. Dirty water, impure milk, and soiled food also spread the germs. If we observe the modern standard of cleanliness which is set by good society, we shall keep ourselves free from most disease germs.

Many diseases are spread by the habit of putting things into the mouth unnecessarily. Sucking the ends of the fingers, wetting the fingers with the lips on turning the leaves of a book, and touching the point of a pencil to the tongue on writing are often the means of spreading diseases.

A grave source of danger is a public drinking cup. It is impossible to take a cup between the lips without leaving saliva on the cup. Germs of tuberculosis have often been found on cups in railroad stations and schools. A public drinking fountain should be so arranged that we may drink directly from a stream of running water without the need of a cup.

725. The weather and infectious diseases.—When the germs of an infectious disease grow in any part of the body, we often say that we have *taken cold* there, but the expression is an uncertain and indefinite one which came into use at a time when the weather was supposed to cause epidemics and pestilences. Infectious diseases are not caused by cold air, or dampness, or any other condition of the weather, for disease germs are seldom found in the open air. During cold, damp weather people often keep their doors and windows closed tightly, and thus they breathe air which is foul and dusty and full of disease germs. They are likely to have nose and throat troubles, and lung diseases which they catch from the bad air of their houses and not from anything wrong with the outdoor air. We may be as free from colds and lung troubles in winter as in summer if we keep our houses and meeting places as clean and well ventilated in cold weather as in the summer time.

Hot weather is often supposed to cause intestinal diseases. These forms of sickness are not due to the heat itself, but are usually caused by spoiled food or by house flies.

726. Suppression of infectious diseases.—There are several reasons why it is difficult to suppress infectious diseases entirely:—

I. A person who is just coming down with a disease may give its germs to others before he knows that he has it. Thus measles may be

spread by a sick child before there are any signs to show that the disease is anything more than a common cold.

2. Some persons may have a disease so mildly that they do not know that they have it. Diphtheria and scarlet fever are usually spread from this kind of cases, for bad cases usually receive care.

3. Germs of a disease may sometimes be found in the mucus and folds of the nose and mouth of healthy persons who are immune, and may spread from them to some one in whom they will grow. Diphtheria is sometimes spread in this way.

4. We cannot always tell how soon a person is free from all germs after he has recovered from a disease. Germs of typhoid fever may remain alive in the gall bladder for years, and thus a person who seems entirely recovered from the disease may be the means of its spread to others.

727. Fever. — While an infectious disease is coming on, the body can throw off the toxins as fast as they are produced. When the germs have multiplied enormously, some of the poisonous toxins will be retained in the body, and then the disease suddenly develops. The toxins produce a headache and a great weakness of the whole body, and cause the heart beats to become weak and rapid. But the principal sign of an infectious disease is usually *fever*. A fever is seldom caused by anything else than the poisons of disease germs which are growing in the body. The poisons, and not the increased heat of the body, are what make a fever dangerous. We can easily lower the temperature of a feverish person, but it does little good unless we also get rid of some of the poisons which cause the fever (p. 263).

728. Cause of Colds. — The most common infectious diseases are what are called *colds*. Colds are caused by several kinds of disease germs which grow in the mucous membrane of the nose and throat. The sickness usually comes on after some part of the body has been wet or chilled, but dampness and cold drafts do not make us take

cold unless we take disease germs into the body. The germs come from persons who have a cold, and are found in whatever is given off from the nose or throat. Tiny drops of saliva and mucus are driven out with every cough and sneeze, and when they are dried, their germs float in the air as dust. Millions of the germs are scattered through the air from every spot of dried phlegm which has been spit upon the floor or pavement, and millions more may be spread from every handkerchief on which the nose has been blown. Colds are extremely common, and thus the germs are widely spread and are likely to be found wherever the air is close and foul. Great numbers float in the air of crowded meeting places, but those who attend the meetings often suppose that they take cold from drafts of fresh air, when the real cause is the germs floating in the foul air. Fresh air is the best of all preventives of colds.

729. Danger from colds. — A cold is usually a harmless kind of sickness, but it is not always so. Some mild colds are caused by the germs of the grippe, or of pneumonia, or of erysipelas, or of whooping cough, and are the means of spreading the diseases to others in bad forms. Many mild sore throats are caused by the germs of diphtheria which may produce the disease in a deadly form in the next person who takes the germs. Thus we should consider any cold to be serious, and should do all that we can to prevent the germs from spreading.

730. Prevention and cure of colds. — Colds are spread chiefly by means of dried sputum, just as tuberculosis is spread, and may be prevented or cured in the same way as tuberculosis (p. 392). A person who has a cold should keep away from other people. He should sleep in a clean room alone, and with a window open to admit fresh air day and night. None of the phlegm should be spit upon the floor or pavement, but it should be caught upon handkerchiefs, and several clean ones should be used each day.

731. Tonsillitis. — The tonsils (p. 193) are often full of deep holes and pockets, in which disease germs may collect and grow. Then the holes may become filled with thick matter, so that the tonsils seem to be spotted with whitish points. These spots are a sign of *tonsillitis*. Every case of tonsillitis is infectious, and should be treated like a severe cold.

732. Diphtheria. — Diphtheria is an extremely dangerous disease whose germs usually start to grow in the tonsils, and there form a whitish patch which looks like a scab on the skin. Sometimes the disease looks like a mild tonsillitis, so that it can hardly be recognized. If a patch covers the tonsils, or if it extends beyond the tonsils, the disease is almost certainly diphtheria.

The germs of diphtheria produce toxins which are extremely poisonous to the heart, so that death often results from the disease. The toxins usually make the throat sore, but sometimes they paralyze the nerves so that no pain is felt, and there are no signs that suggest a throat trouble. Then the disease may not be noticed until it is too late to be cured. Yet if the disease is severe, any one can easily see the patches by looking into the throat. The disease usually occurs in children, but grown people may also take it.

733. Prevention of diphtheria. — Germs of diphtheria are long-lived, and are hard to kill. They are found in everything which comes from the nose and throat of a person who has the disease, and they may rise as dust from anything on which they have dried. They are likely to be shaken from bedclothes, handkerchiefs, and clothing, and to settle on the carpets and furniture. So every person who has diphtheria should be closely quarantined (p. 410). At the end of the disease the room and everything which the sick person has used should be disinfected and made free from the germs in the most thorough manner (pp. 387 and 411). After the sick are entirely well they should not mingle with other persons for at least two weeks, for a few germs may still remain alive in the throat. The only way to be sure that no germs

are left in the throat is to send a specimen of the throat discharge to a laboratory to see if the germs can be found.

734. Diphtheria antitoxin.—Antitoxin should be given to every one who has diphtheria and to every person who lives in a house where the disease is (p. 386). A small dose of antitoxin will prevent the disease from developing in any one who has just taken the germs into the body. If the disease has already started, a larger dose will stop the growth of the germs, but it will not overcome the damage

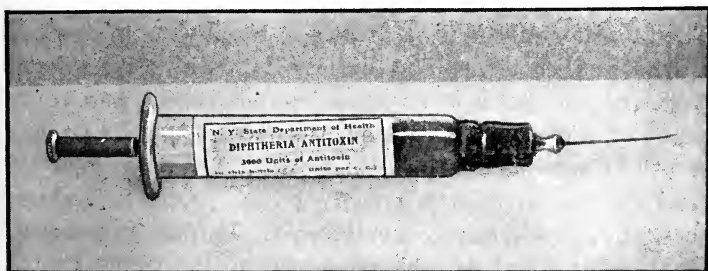

A syringe full of antitoxin, as it is sent from the laboratory.

that has already been done by the toxins. When it is used early, it is an almost sure cure for the disease. Owing to its extensive use, the number of deaths yearly from diphtheria in New York State is less than half what it was before the antitoxin was discovered. Nearly all of those who now die either did not receive the antitoxin, or else received it late in the disease. Its value is so great that many states now furnish it free to those who are unable to purchase it.

735. Pneumonia.—Disease germs growing in the lungs produce the sickness called *pneumonia* (p. 401). Pneumonia is one of the most frequent causes of death, and is always a serious disease from which recovery is slow. Persons who have any kind of serious illness, such as

typhoid fever or the grippe, are also likely to take pneumonia if they breathe foul or dusty air, or live in a room with any one who has a bad cold. A common way of taking pneumonia is to breathe the foul air of a hot, close room after becoming exhausted and chilled in stormy weather. Pure air is the most essential thing in preventing pneumonia.

A pneumonia which is caused by the germs of tuberculosis is called *consumption* (p. 389).

736. Whooping cough. — Whooping cough is due to a kind of disease germ which is breathed into the nose and throat. The toxins of the germs cause the sick person to have short spells of coughing until he is out of breath. Then he suddenly takes a breath so forcibly as to produce a whooping noise. The disease is usually considered harmless, and yet it often produces pneumonia and is the cause of thousands of deaths each year. One who has had the disease is usually immune to it for the rest of his life. It seldom affects grown people, probably because nearly everybody has it in childhood. It lasts from one to three months, and may be given during the whole course of the disease.

Whooping cough may be caught by being in a room with a person who has the disease, and yet its germs are not long-lived, and are not likely to be carried on the clothing, or to remain alive in a room after the disease is at an end. It may be prevented by keeping the sick away from those who have not had the disease. Every person who has it should remain away from school, and church, and other meeting places.

737. Inflamed wounds. — Germs of disease may enter the flesh through any wound in the skin. The disease which they cause is often called a cold in the wound, or an inflamed wound, or erysipelas, or blood poisoning. It may be prevented by covering all wounds with clean, antiseptic

dressings (p. 400). Soldiers in time of war often die as the result of inflammation in their wounds, but in the great war between Japan and Russia few Japanese died from this cause, for each soldier carried a case of dressings and was taught how to apply the dressing at once after receiving a wound.

738. Intestinal diseases.—Several kinds of disease germs may grow in the intestine. The intestine increases its peristalsis (p. 85) in an attempt to expel the toxins, and thus the germs are the cause of abdominal pains, and stomach aches, and dysentery.

Babies often suffer greatly from intestinal diseases, for in them the toxins of disease germs are absorbed more readily than in grown persons. The germs of intestinal diseases usually enter the body with impure water or spoiled food, or are deposited on the food by house flies which come into our kitchens from filthy garbage heaps. Intestinal diseases may be suppressed by attention to the purity of drinking water and food, and by the extermination of house flies (p. 411). Owing to increased knowledge in the care of milk, the amount of intestinal diseases among babies has been greatly lessened (p. 110).

739. Typhoid fever.—One of the most serious forms of sickness which is caused by impurities in drinking water and food is typhoid fever. The disease is like a severe and prolonged dysentery, and is the cause of thousands of deaths each year.

We take typhoid fever only by swallowing the germs which have grown in the intestine of a sick person. The germs are given off in the discharges from the body of any one who has the disease. They may remain alive in garbage heaps and slops and sewage, and so may reach our drinking water, or be carried to our food by house flies. They may also be deposited on dishes or milk cans which have been washed in impure water.

Typhoid fever may be prevented by proper sewage disposal and the

extermination of house flies. It is not carried by the air or the dust of the sick room, and so quarantine of the sick room is not necessary. But it may be carried by soiled bedclothes, or on the hands of the nurse. It is necessary to be careful in the cleanliness of everything in the sick room, and to dispose of all slops and sewage in such a way that the germs in them cannot escape.

Cholera is an intestinal disease which is spread in the same way as typhoid fever. It is seldom seen in civilized lands, but is common among people who drink river water which is full of sewage.

740. Mumps.—Mumps is caused by the growth of a kind of microbe in the salivary glands, producing swellings around the lower jaw. It seldom causes a severe illness. Its germs are not long-lived and do not readily spread. The disease may be suppressed by keeping the sick away from well persons, and by washing their dishes and towels and handkerchiefs separately from those used by other persons.

741. Eruptive diseases.—There are a number of infectious diseases in which spots appear on the skin. For this reason they are called *eruptive diseases*. The common eruptive diseases are measles, scarlet fever, chicken pox, and smallpox. A person who has had one of these diseases is usually immune to it for the rest of his lifetime.

The eruptive diseases are caused by germs whose exact nature has not been discovered. The germs may live in clothing, or carpets, or other things which are laid away in a dark, close room, but they soon die when they are exposed to the sunlight and fresh air. The diseases are usually spread by well persons living in the same room or house with the sick, or by using some article which the sick have handled. They may be suppressed by closely quarantining the sick, thoroughly cleansing everything in the sick room, and properly disposing of all slops and sewage from the sick. The chief obstacle in the way of entirely stamping out the diseases is the great difficulty of recognizing extremely mild cases of the diseases in which few or no spots are seen.

742. Measles. — Measles starts like a common cold, and on about the fourth day of the disease red spots appear over the whole body. The sickness is so mild that little attempt is usually made to control its spread. Yet it may weaken the body so that pneumonia, kidney diseases, and other severe forms of sickness may follow it, and thus it is the cause of thousands of deaths each year. Its germs are not usually long-lived. The disease would soon be suppressed if every case of measles were kept away from other persons for two weeks, and if everything about the sick room were kept clean and well aired.

743. Scarlet fever. — Scarlet fever is one of the most dangerous of the contagious diseases, and yet it does not cause more deaths than measles, for most persons fear it and take pains to suppress it when it appears in a town. It usually comes on suddenly and produces vomiting and pains in the head and back. Fine red spots appear on the skin within a day or two, and there is a sore throat due to spots in the mouth. After the disease is at an end, coarse flakes of the outer skin peel off for two or three weeks, in even the mildest cases. When we are in doubt if a person has the disease, we should wait to see if the skin peels off. Scarlet fever may be suppressed by strict quarantine and cleanliness.

744. Chicken pox. — Chicken pox is a common disease in which small spots like blisters appear on the skin. It seldom causes a severe sickness, and yet it is important, for it closely resembles mild smallpox. It is very rarely seen in grown persons, and so if a grown person seems to have it, the disease is likely to be smallpox. It may be suppressed by keeping the sick at home and away from those who have not had it.

745. Smallpox. — Smallpox was once one of the most common and deadly of all forms of sickness. Before the year 1800 it had often swept over Europe in waves of

pestilence from which few persons escaped, and had almost exterminated the native tribes of some parts of America; but since that time it has been largely controlled owing to the wide use of a method of conferring immunity to the disease.

Smallpox begins as a painful fever, and in about four days the skin breaks out with raised spots which become filled with a creamy pus, and leave deep scars at the end of the disease. The disease sometimes occurs in a mild form which is mistaken for chicken pox, and yet those who take it from these mild cases may have it in its most severe form.

Smallpox usually spreads directly from the sick to those who come near them. Clothing and other things which the sick have handled may also be the means of spreading the disease even months after the sick are well, for the germs are long-lived if they are kept from the air and sunlight. Every case of smallpox should be closely quarantined, and nothing should be taken from the sick room unless the germs on it are destroyed.

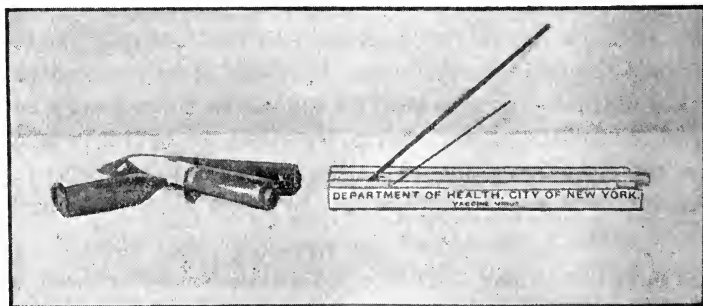

Vaccine.

On bone points, inclosed in glass cases. In liquid form, in a small sealed tube.

746. Vaccination. — There is a mild disease among cows called *cowpox* or *vaccinia*, in which the skin breaks out as in a mild smallpox in man. If a bit of the matter from one of the sores is rubbed upon a scratch on a person's arm the germs produce a sore spot on the skin, and at the same

time they cause the body to produce substances which will prevent the growth of smallpox germs in the person. This method of immunizing the body is called *vaccination*, from the name of the disease in cattle. It was discovered by an English physician named Edward Jenner.

It is doubtful if quarantine and attention to hygiene would be sufficient to prevent the spread of smallpox, for mild cases sometimes occur which are not recognized until some one catches the disease in a bad form. Vaccination is an almost sure protection against these unrecognized cases, and very few vaccinated persons who are exposed to severe smallpox take the disease. Every child should be vaccinated before going to school and again a few years later. Objection is often made to vaccination because it has sometimes been followed by severe sickness when it has been done with impure vaccine or in a dirty manner. Pure vaccine can now be bought at most drug stores. If it is used in a clean manner, and the vaccinated spot is kept clean, there are no bad results after vaccination.

747. Lockjaw. — *Lockjaw*, or *tetanus*, is caused by a kind of bacteria which grow in a wound. Their toxins poison the nerve cells so as to produce convulsions which usually end in death. The bacteria are often found in the soil of gardens and roads, and reach our flesh through wounds. They cannot grow in the presence of much air, and so they seldom grow in clean, open wounds, but they are likely to grow where they are thrust deep into the flesh, as by dirty nails. They are also likely to grow in wounds made by fireworks on the Fourth of July, for the dead and burned flesh keeps out the air. Lockjaw can usually be prevented by covering all wounds with clean antiseptic dressings. An antitoxin against lockjaw can be bought at drug stores, and should be given soon after a person receives a wound in which there is dirt from soil.

748. Rabies. — Rabies, or *hydrophobia*, is a deadly form of sickness which resembles lockjaw, and is caused by large germs which are

found in the cells of the brain, and in the saliva. It is caught from the bite of dogs or cats which have the disease. It is spread mostly by means of homeless animals. Dogs running loose should be muzzled, and stray ones should be caught by a public dog catcher. If a person is bitten, the animal should be securely shut up to see if it has the rabies. If it has the disease it will soon die, but if it remains alive the wound is no more serious than one made by a needle. The germs in a bite may be killed by opening the wound and cauterizing it to the very bottom. In those bitten by a rabid animal the disease may be prevented by injecting an immunizing substance prepared from rabbits which have been given the disease. This substance may be had by application to the boards of health of the greater cities.

749. The plague.—The black plague is a pestilence which has often appeared in Europe. It killed half the inhabitants there in the fourteenth century. It still exists in some parts of the world, and is as deadly as ever when it is allowed to go unchecked. It is due to bacteria which produce swellings and abscesses in the flesh. It seldom spreads from one person to another, but the bacteria are carried from rats, which have the disease, to persons by means of fleas. Its control and suppression depend principally on the extermination of rats.

750. Hook-worm disease.—A kind of intestinal worm called the *hook worm* produces a sickness in which there is an intense feeling of lifelessness or laziness. The worms lay eggs which hatch in the ground. The young bore their way through the skin and finally fasten themselves by tiny hooks to the inside of the intestine and become about a half an inch in length. They produce their bad effects by sucking blood from the mucous membrane. They may be killed by medicines which kill other intestinal worms. The disease may be prevented by disposing of all sewage so that the eggs and young worms cannot reach the soil where people work. Cleanliness and

wearing shoes are also necessary in order to keep the young worms away from the skin. The disease is widely spread in the warmer parts of the United States, and is the cause of much suffering which was once supposed to be due merely to shiftlessness and laziness.

SUMMARY

1. Infectious diseases are common during cold and damp weather because then people shut themselves in close rooms containing disease germs.
2. Disease germs may spread from a mild case of infectious disease as well as from a severe case.
3. Resistance in infectious diseases can be increased by anything which promotes the vigor of the body.
4. The germs of infectious diseases are found in the discharges from the bodies of the sick.
5. Quarantine and proper sewage disposal are necessary in suppressing infectious diseases.
6. The toxins of disease germs cause a fever.
7. Colds are caused by disease germs, and are infectious.
8. A person who has diphtheria should be quarantined and should receive antitoxin.
9. Vaccination is the only safe and sure preventive of smallpox.
10. Antitoxin is a safe and sure preventive of diphtheria.
11. Typhoid fever and other intestinal diseases are spread by impure water and milk, and by house flies.
12. Rats and stray dogs are a menace to health.

DEMONSTRATIONS

183. Show the class specimen vaccine points and tubes of antitoxin borrowed at a drug store. Explain the ease and safety of their use.

184. Show a thermometer which is used in taking the temperature of the body, and explain how it is used.

185. Trace the origin and cause of the colds of some of the members of the class. Determine which were evidently caused by exposure to dampness and cold air, and which were due to breathing foul air or contact with other persons who had colds.

REVIEW TOPICS

1. Explain why infectious diseases seem to be largely, due to the weather.
2. Give some reasons why it is difficult to suppress infectious diseases entirely.
3. What is meant by *immunity*? How may it be increased?
4. How may we increase the power of our body to resist the growth of disease germs?
5. How do vaccines and antitoxins produce immunity to a disease? Discuss their use.
6. Mention some of the means by which disease germs may be spread from a sick person.
7. What is the cause of fever?
8. Discuss the cause and prevention of colds.
9. Why should we consider a cold to be a dangerous form of sickness?
10. How may we recognize that a person has diphtheria? How can we prevent the disease?
11. How may we prevent pneumonia?
12. How may we prevent erysipelas?
13. Discuss the advisability of quarantining every case of whooping cough, measles, mumps, and chicken pox.
14. What are some of the usual causes of intestinal diseases?
15. What methods should be taken to prevent the spread of scarlet fever, diphtheria, and smallpox?
16. Discuss the cause and prevention of lockjaw; of rabies; of hook-worm disease.

CALIFORNIA COLLEGE of PHARMACY

GLOSSARY.

- Ab-do'men** (Lat. *abdomen*, belly), the cavity of the body which contains the stomach, intestine, liver, pancreas, and spleen.
- Ab'scess** (Lat. *abs*, away, and *cedere*, to move), a collection of dead creamy matter in the flesh of a living person.
- Ab-sorp'tion** (Lat. *ab*, away, and *sorbere*, to soak in), taking a substance into the tissues of the body, without change in its composition.
- Ac-com-mo-da'tion** (Lat. *ad*, to, *con*, with, and *modus*, measure), adjusting the lens of the eye to the proper shape to cause the image of an object to fall upon the retina.
- A'cid** (Lat. *acere*, to sour), any sour, irritating substance, which will corrode other substances.
- A'con-ite** (Gr. *akoniton*, the plant commonly called monkshood), an extremely poisonous plant. It is used to lower fevers. In overdoses it produces extreme weakness of the whole body.
- Ad'e-noid vegetations** (Gr. *aden*, gland, and *eidosis*, form), collections of soft, grape-like bodies growing in the upper part of the pharynx. They are common in children.
- A-dul'ter-ate** (Lat. *ad*, to, and *alter*, another), to make impure by an admixture of an inferior substance.
- Al-bu'min** (Lat. *albus*, white, because it generally turns white when heated), a term applied to a class of substances, some form of which is the essential part of every living cell. It is composed of the elements carbon, hydrogen, nitrogen, oxygen, and sulphur. The form of albumin which is found in the white of an egg is spelled *albumen*.
- Al'co-hol** (Ar. *al-kohl*, a powder of antimony used in painting the eyebrows), on account of its extreme fineness the name came to be applied to the product formed by repeatedly distilling wine, for this was supposed to be the real "spirits" of the wine.

- Al-i-men'ta-ry** (Lat. *alere*, to feed), having nourishing qualities capable of being used as a food, or pertaining to food.
- Al'ka-li** (Ar. *al*, the, and *kali*, a plant whose ashes were used in making glass), a substance whose properties are in contrast with those of an acid. An alkali forms soap when united with an oil.
- Al'ka-loid** (Ar. *alkali*, and *eidos*, form), the substance in certain vegetable drugs which gives the drugs their characteristic qualities. A small dose of an alkaloid produces the same effect as a large dose of the drug from which it is derived.
- A-me'ba** (Gr. *amoibe*, change), the simplest form of animal life, consisting of a single lump of jelly, capable of changing its shape at will.
- Am-y-lop'sin** (Gr. *amulon*, starch), the ferment in the pancreatic juice which changes starch to glucose.
- A-nat'o-my** (Gr. *ana*, up, and *temnein*, to cut), the science which tells of the structure of living bodies.
- An-e'mia** (Gr. *a*, without, and *haima*, blood), the state of the blood in which there are too few red blood cells and too little plasma.
- An-es-the'si-a** (Gr. *an*, not, and *aisthanesthai*, to perceive), a temporary lack of sensibility produced by drugs.
- An'ti-dote** (Gr. *anti*, against, and *didonai*, to give), a substance which prevents a poison from acting upon the cells when it is introduced into the body.
- An-ti-sep'tic** (Gr. *anti*, against, and *sepein*, to rot), a substance which prevents the growth of bacteria, and hence prevents rotting.
- An-ti-tox'in** (Gr. *anti*, against, and *toxikon*, poison), a substance which is produced in the body to overcome the poison of a disease. It is commonly applied to a substance used in the treatment of diphtheria.
- An'trum** (Gr. *antron*, a cave), the hollow cavity within the upper jaw bone.
- A-or'ta** (Gr. *aeirein*, to lift up), the large artery which rises from the left side of the heart, and distributes blood to all parts of the body.
- Ap-o-plex'y** (Gr. *apo*, from, and *plessein*, to strike), a sudden loss of consciousness, usually due to pressure upon the brain caused by a burst artery.
- Ap-pen-di-ci'tis**, inflammation of the vermiform appendix.
- Ap'pe-tite** (Lat. *ad*, to, and *petere*, to seek or long for), a strong desire for something. It is used mainly of the desire for eating and drinking.
- A'que-ous hu'mor** (Lat. *aqua*, water, and *humor*, a liquid), the liquid which fills the eyeball in front of the lens.

- Ar'gon** (Gr. *a*, not, and *ergon*, work), a gas (discovered in 1894) which forms about one per cent of the air. It resembles nitrogen.
- Ar'sen-ic** (Gr. *arsenikon*), a gray metal whose combinations with oxygen are very poisonous.
- Ar'ter-y** (Gr. *aer*, air, and *terein*, to hold), the tubes which conduct blood to the cells of the body. After death they are empty, and it was formerly supposed that in life they contained only air.
- As-phyx'i-a** (Gr. *a*, not, and *sphuzein*, to throb), death by suffocation.
- As-sim-i-la'tion** (Lat. *ad*, to, and *similis*, like), the process of changing digested food to substances like those which compose the body.
- A-stig'ma-tism** (Gr. *a*, not, and *stigma*, a point), the condition of an eye in which one part of the rays are brought to a focus sooner than another part.
- Au'ri-cle** (Lat. *auris*, an ear), the upper two cavities of the heart. They are thin and resemble dog's ears.
- Bac-te'ri-um** (pl. bacteria) (Gr. *bacterion* a staff), the simplest and smallest form of plant life, consisting of a tiny sphere or rod. Some kinds can grow in the human body and produce disease.
- Bel-la-don'na** (Ital. *bella*, beautiful, and *donna*, lady), an herb which produces excitement of the brain and great weakness. It enlarges the pupils of the eyes, and was formerly used by ladies to render themselves more beautiful.
- Bi'ceps** (Lat. *bis*, twice, and *caput*, head), the muscle upon the front of the upper arm which bends the elbow. Its upper end has two branches.
- Bi-chlo'ride of mer'cu-ry**, a compound of mercury and chlorine. It is very poisonous especially to bacteria of disease. When dissolved in water in the proportions of one part to five thousand, it kills disease germs.
- Bi-cus'pid** (Lat. *bis*, twice, and *cuspis*, a point), the fourth and fifth teeth from the middle upon each side of each jaw; each bicuspid ends in two points.
- Bile** (Lat. *bilis*), a yellow, bitter fluid formed by the liver cells and poured into the intestine. It is a part of the waste of the body, but while it is being excreted it assists the pancreatic juice and intestine in performing their work.
- Bil-i-ru'bin** (Lat. *bilis*, bile, and *ruber*, red), the coloring matter of the bile. It consists of broken down hemoglobin.

- Blad'der**, a thin muscular bag in which a fluid is stored in the body. It is especially applied to the bag in the pelvis containing urine.
- Brain**, the mass of nerve cells and nerve fibers which is inclosed within the skull. It is the seat of the consciously acting mind.
- Bright's disease**, almost any disease of the kidneys. Dr. Bright gave the first true description of kidney diseases. He died in 1858.
- Bron'chus** (Gr. *brogchos*, the windpipe), one of the numerous branches into which the trachea divides. It is applied to the smallest subdivisions as well as to the two main branches.
- Bun'ion**, a swelling of the great toe joint caused by tight shoes.
- But'ter-ine**, artificial butter made from butter and suet.
- Cæ'cum** (Lat. *caecus*, blind), the blind or closed end of the large intestine; the small intestine opens into the side of large intestine about an inch from its end.
- Caf-fe-ine** (*ka-fe'in*), a white, bitter alkaloid obtained from coffee.
- Cal'lus** (Lat. *callus*), hard and thickened epidermis. It is caused by rubbing a part during hard work, and is nature's way of protecting the deeper parts from injury.
- Can-cel'lous** (Lat. *cancelli*, a lattice), having an open or porous structure.
- Cap'il-la-ry** (Lat. *capillus*, a hair), a hair-like blood tube. Capillaries surround each cell of the body. From them plasma and oxygen go out from the blood to nourish the cells.
- Car-bol'ic acid** (Lat. *carbo*, coal, and *oleum*, oil), a poisonous substance obtained from coal tar. It is commonly used to kill disease germs and to prevent decay.
- Car'bon** (Lat. *carbo*, coal), a substance, of which the diamond is the pure crystallized form. Coal, charcoal, and lampblack are more common forms. Combined with other substances it is a part of the bodies of all animals and plants.
- Car-bon'ic acid gas**, a heavy, colorless gas formed when carbon burns.
- Car'di-ac** (Gr. *kardia*, heart), pertaining to the heart. It is also applied to the left end of the stomach, which lies just under the heart.
- Car'pal bones** (Gr. *karpōs*, wrist), the bones of the wrist.
- Car'ti-lage** (Lat. *cartilago*), the soft substance commonly called gristle which covers the ends of bones within joints.

- Casein** (*ka'se-in*) (Lat. *caseus*, cheese), the part of the albumin of milk which forms the curd or clabber. In cow's milk nearly all the albumin is casein. The remaining albumin coagulates and forms a scum when the milk is heated.
- Cat'a-ract** (Gr. *kata*, down, and *rhegnunai*, to break), a cloudiness of the lens of the eye which shuts out the light.
- Catarrh** (*katar'*) (Gr. *kata*, down, and *rhein*, to flow), an excessive production of mucus from the nose and throat.
- Cells** (Lat. *cella*, a cavity), the smallest particles of the body capable of fulfilling the tests of life.
- Cel'lu-lose** (Lat. *cellula*, a little cell), a substance which forms most of the framework of vegetable tissues.
- Ce-ment'** (Lat. *caementum*, a builder's stone), the soft bone-like substance which fixes the teeth in their sockets in the jaws.
- Cer-e-bel'lum** (Lat. *cerebellum*, little brain), the rounded part of the brain situated under the cerebrum and above the medulla. It assists the brain to direct precise movements, as movements in which the body is balanced.
- Cer'e-brum** (Lat. *cerebrum*, brain), the uppermost part of the brain. In man it covers all the rest. It is the seat of consciousness and of thought. It receives all sensations, and sends all voluntary impulses to produce motion.
- Chem'is-try**, the science of the composition of substances. It is concerned in destroying or decomposing substances, and in forming new substances having different properties from the original substances.
- Chlo'ral** (*klo'ral*), a substance made from *chlorine* and *alcohol* and used to produce sleep.
- Chlo'ride** (*klo'ride*), a combination of the gas *chlorine* with another substance. Chloride of lime is used to kill disease germs. Chloride of sodium is common salt.
- Chlo'ro-form**, a volatile liquid made from *chlorine* and *formyl*. When its vapor is inhaled for some minutes it produces a deep sleep and complete insensibility to pain. When its inhalation is stopped, consciousness soon returns. It is used in surgical operations.
- Chlo'ro-phyll** (Gr. *chloros*, green, and *phullon*, leaf), the green coloring matter of leaves. It forms starch out of carbonic acid and water.
- Chol'e-ra** (Gr. *chole*, bile), a contagious disease of the intestine in which there is great pain, and an increased excretion and peristalsis.

- Cho'roid** (Gr. *chorion*, skin, and *eidōs*, form), the middle lining of the eye. It carries the blood vessels for the nourishment of the inner parts of the eye.
- Chyle** (*kīle*) (Gr. *chulos*, juice), the liquid produced by intestinal digestion.
- Chyme** (*kīme*) (Gr. *chumos*, juice), the partly digested contents of the stomach as they enter the intestine. The word is falling into disuse.
- Cilia** (*sil'i-a*) (Lat. *cilia*, eyelashes), microscopic hairs upon the surface of certain cells. They are in constant motion to sweep out secretions and dust. They line the trachea and bronchi.
- Clab'ber**, or bonny-clabber (Irish *baine*, milk, and *clabar*, mud), sour and curdled milk.
- Clav'i-cle** (Lat. *clavis*, a key), the slender bone which extends from the breast bone to the shoulder. The collar bone.
- Co-ag-u-la'tion** (Lat. *con*, together, and *agere*, to force), the process of changing a liquid to a solid form of a different nature from the original liquid. Thus in curdled milk coagulation has taken place.
- Cocaine** (*ko'ca-in*), a bitter, white substance obtained from coca. It benumbs pain when applied to the nerves and produces excitement of the brain.
- Coccyx** (*kok'six*) (Gr. *kokkux*, a cuckoo), the small bone which forms the lower end of the backbone. It is shaped somewhat like a cuckoo's bill.
- Cochlea** (*kok'le-a*) (Lat. *cochlea*, snail shell), the coiled canal of the inner ear in which the nerves of hearing end.
- Cold**, an unhealthy state of a part of the body caused by exposure to coldness and dampness. It is an increased activity of the cells and an increased blood supply due to nature's attempt to repair the injury caused by the exposure. The injury is usually due to the growth of disease germs.
- Co'lon** (Gr. *kolon*), the large intestine.
- Con-ges'tion** (Lat. *con*, together, and *gerere*, to bring), overfullness of the blood tubes of a part of the body. It is the first stage of repair of wounds and of inflammation, and is nature's way of supplying an excess of nutrition to repair an injured spot.
- Con-junc-ti'va** (Lat. *conjunctivus*, joined together), the mucous membrane lining the eyelids and covering the front of the eyeball.

- Connective tissue**, the stringlike cells scattered through the whole body to keep the other cells of the body in place.
- Conservation of energy**, the law that no force is destroyed, but can be recovered as heat, electricity, motion, or in other forms.
- Contagious disease** (*kon-ta'jus*) (Lat. *contagio*, a touch), an infectious disease which can be transmitted through the air.
- Con-trac'tion** (Lat. *con*, together, and *trahere*, to draw), the shortening and thickening of a muscle to produce movement in a part of the body.
- Cook** (Lat. *coquere*), to prepare food by the use of heat.
- Cor'ne-a** (Lat. *corneus*, horny), the round, bulging window in the front of the eyeball through which light enters the eye.
- Cor'pus-cle** (Lat. *corpusculum*, a little body), one of the cells which float in the plasma of the blood.
- Cra'ni-al** (Gr. *kranion*, skull), pertaining to the contents of the skull or brain.
- Cricoid cartilage** (*krī'koid*) (Gr. *krikos*, a ring, and *eidōs*, form), the ring which forms the lower part of the larynx.
- Cud**, the food which most cloven-hoofed animals bring up from the stomach to chew the second time.
- Cu'ti-cle** (Lat. *cuticula*, little skin), the outer and insensitive layer of skin. The epidermis.
- Cu'tis** (Lat. *cutis*, skin). A more common name is the derma.
- Deg'lu-ti'tion** (Lat. *de*, from, and *glutire*, to swallow), swallowing.
- De-lir'i-um** (Lat. *delirare*, to rave), a state of mind in which judgment and reason are disordered and illusions of the senses are present. It is usually caused by fevers.
- Delirium tre'mens**, a form of delirium which occurs in drunkards. It causes the sufferer to struggle violently to escape the torments of his imagination.
- Der'ma** (Gr. *derma*, skin), the true skin, or the part beneath its insensitive covering.
- Di'a-phragm** (Gr. *dia*, through, and *phragnumai*, to fence), the muscular partition extending across the cavity of the body and dividing the chest from the abdomen. It is the main muscle of breathing.
- Diastole** (*di-as'to-le*) (Gr. *dia*, through, and *stellein*, to place), the relaxation of the heart during which it is being filled with blood in preparation for another beat.

- Diffusion** (Lat. *diffusio*), the act of passing through membranes apparently impervious. Thus, peptone passes by diffusion through the sides of the blood tubes in the walls of the intestine, and reaches the blood.
- Di-ges'tion** (Lat. *dis*, apart, and *gerere*, to carry or wear), changing food into such forms that it can pass through the walls of the blood tubes and become a part of the blood.
- Diph-the'ri-a** (Gr. *diphthera*, leather), an infectious disease in which there is a skin-like membrane covering the affected part, usually the throat.
- Dis-lo-ca'tion** (Lat. *dis*, apart, and *locare*, to locate), the separation of two bones whose union forms a joint.
- Dis-til-la'tion** (Lat. *de*, from, and *stillare*, to drop), the process of separating a substance which easily becomes a vapor from one which forms a vapor less easily. Heat is applied to the substance, and the vapor is *cooled* or *condensed* to a liquid in a coil of tube from which it runs in drops, and hence the name. As far back as the year 1200 the process was used by the Arabs in their endeavors to find an essential spiritual principle which would sustain life and restore youth.
- Drop'sy**, a uniform swelling of a part without pain or redness. It is an accumulation of lymph due to a disturbance in the circulation of the blood.
- Duct** (Lat. *ducere*, to lead), any tube which conducts a secretion away from a gland.
- Du-o-de-num** (Lat. *duodeni*, twelve), the beginning of the small intestine for the length of about twelve finger breadths.
- Du'ra ma'ter** (Lat. *dura*, harsh, and *mater*, mother), the periosteum lining the skull. It is very thick and sends prolongations into the main fissures of the brain to hold the brain in place.
- Dys-pep'si-a** (Gr. *dus*, ill, and *peptein*, to cook or digest), imperfect digestion of the food.
- E-mul'sion** (Lat. *e*, out, and *mulgere*, to milk), a milky-looking liquid consisting of microscopic drops of oil floating in a liquid.
- En-am'el**, the hard calcified tissue which covers the exposed parts of the teeth.
- En'er-gy** (Gr. *en*, in, and *ergon*, work), any force which can be made to do work. The energy of the body can be traced to oxidation within the cells.

- Ep'i-der'mis** (Gr. *epi*, upon, and *derma*, skin), the thin insensitive layer of cells upon the outside of the skin. It is sometimes called the cuticle.
- Ep-i-glott'is** (Gr. *epi*, upon, and *glotta*, the tongue), the leaf-like lid upon the back of the tongue which closes the larynx when swallowing.
- Ep'i-lep-sy** (Gr. *epilepsis*, a seizure), a disease in which, at intervals a person suddenly falls to the ground unconscious, while all the muscles of the body contract strongly.
- Ep-i-the'lium** (Gr. *epi*, upon, and *thelē*, nipple), the cells which cover the skin and mucous membrane and line the tubes of glands. Epithelium is a protection for the body, and does all the work of secretion and absorption.
- Er-y-sip'e-las** (Gr. *eruthros*, red, and *phella*, skin), a disease of the skin in which there is pain, redness, and swelling. It is caused by the growth of bacteria of disease in a wound. It varies in severity from a simple matured scratch to a severe blood poison.
- E-soph'a-gus** or **œ-soph'a-gus** (Gr. *oiso*, I shall carry, and *phagein*, to eat), the tube connecting the mouth with the stomach.
- E'ther** (Gr. *aithēin*, to burn), a colorless liquid which evaporates with such great rapidity that its vapor may catch fire if near a lamp. It is used to dissolve gums, and also, like chloroform, to produce insensibility during surgical operations.
- E'ther** (Lat. *aether*, the upper pure air where the gods abode, in distinction from the lower or true air in which man lived), the substance which is supposed to pervade all space, and whose vibrations are supposed to form light, heat, and electricity.
- Eustachian tube** (*yu-sta'ki-an*), the tube leading from the middle ear to the pharynx. It is named after its discoverer, Eustachi, an Italian physician, who died in 1574.
- Ex-cre'tion** (Lat. *ex*, out, and *cretus*, sifted), a waste substance extracted from the blood by the epithelium of a gland.
- Ex-pi-ra'tion** (Lat. *ex*, out, and *spirare*, to breathe), breathing out air from the lungs.
- Ex-ten'sor muscles** (Lat. *ex*, out, and *tendere*, to stretch), the muscles which straighten limbs.
- Fat**, a white greasy substance composed of carbon, hydrogen, and oxygen, but with much less oxygen than is in starch.
- Fe'mur** (Lat. *femur*), the thigh bone.

- Fer'ment** (Lat. *fervimentum*, boiling), a substance a small amount of which produces a chemical change in a large amount of another substance without losing its own identity or characteristics. During the process the most common ferment—yeast—liberates bubbles of gas, like a boiling.
- Fe'ver** (Lat. *febris*, a fever), increased warmth of the body due to poisons of disease.
- Fi'brin** (Lat. *fibra*, a thread), the stringy threads of coagulated blood albumin which permeate the blood and imprison its cells and plasma, causing it to become jellylike or clotted.
- Fib'u-la** (Lat. *fibula*, clasp), the long bone upon the outside of the shin bone.
- Fil-tra'tion** (Lat. *feltrum*, felt), separating a solid from a liquid by straining it through a porous substance.
- Fis'sure** (Lat. *fissura*, a cleft), one of the deep furrows upon the surface of the brain.
- Fit**, a sudden state of unconsciousness and of contraction of the muscles lasting only a minute or two. Epilepsy is a kind of fit.
- Flex'or muscles** (Lat. *flectere*, to bend), muscles which bend the limbs.
- Fo'cus** (Lat. *focus*, a fireplace), the point where rays of light come together when passed through a lens.
- Food**, anything which is assimilated by the body, and gives it weight, heat, or energy. The term includes water and mineral matter as well as vegetable and animal substances.
- Front'al** (Lat. *frons*, the forehead), pertaining to the region of the skull or brain behind the forehead.
- Ful'crum** (Lat. word meaning a prop), the fixed support around which a lever turns.
- Gall** (*gawl*), a name applied to the bile while it is stored in the bag under the liver.
- Gan'gli-on** (Gr. *gaglion*, a knot), a collection of nerve cells in the sympathetic system. Each looks like a grain kernel.
- Gas'tric** (Gr. *gaster*, stomach), pertaining to the stomach.
- Gelatine** (*jel'a-tin*) (Lat. *gelare*, to harden), a kind of albumin which forms the principal part of connective tissue. It will dissolve in hot water, and forms a jellylike or solid mass when cold. Glue is an impure form.

- Germ**s (Lat. *germen*, a bud), a name loosely applied to bacteria.
- Giz'zard**, the muscular organ in a fowl's abdomen which grinds food to pieces and acts in place of teeth.
- Gland** (Lat. *glans*, an acorn), a collection of microscopic tubes which form a watery substance within the body.
- Glu'cose** (Gr. *glukus*, sweet), a form of sugar found in the grape, and produced artificially by the action of sulphuric acid on starch; it is also produced in the body by the action of the digestive fluids upon starch and sugar.
- Glu'ten** (Lat. *gluten*, glue), the albumin of grain.
- Gly-co-chol'ic acid** (Gr. *glukus*, sweet, and *chole*, bile), one of the principal waste substances in the bile.
- Gly'co-gen** (Gr. *glukus*, sweet, and *gainein*, to generate), a form of sugar to which digested sugar and starch is turned by the liver.
- Gout** (*gowt*) (Lat. *gutta*, a drop), a swelling of a joint, especially of the great toe, caused by a disturbance of digestion and oxidation. It was formerly supposed to be due to a fluid or humor which flowed down in drops from the upper parts of the body.
- Grippe** (*grip*) (Fr. *grippe*, influenza), a kind of fever which occurs in epidemics. It is caused by the growth of a germ in the body.
- Hash'eesh**, the gum of a kind of hemp. It produces an excited and dreamy state of mind.
- Ha-ver'si-an canals**, the minute tunnels in bone through which the arteries run. They were discovered by Havers, an English physician, who lived in the seventeenth century.
- Hem-o-glo'bin** (Gk. *haima*, blood, and Lat. *globus*, a ball), the coloring matter of the red blood cells.
- Hem-o-phil'i-a** (Gr. *haima*, blood, and *philein*, to love), a state of the blood in which it will not clot.
- Hem'or-rhage** (Gr. *haima*, blood, and *rhegnunai*, to break), a flow of blood from a blood tube.
- Hi-ber-na'tion** (Lat. *hibernus*, wintry), passing the winter in a torpid state, as frogs and snakes do.
- Hu'mer-us** (Lat. *humerus*), the long bone in the upper part of the arm.
- Hu'mors** (Lat. *humor*, moisture), substances which were formerly supposed to circulate in the blood and to cause disease.
- Hy-dro-chlor'ic acid**, a compound of *hydrogen* and *chlorine*, commonly called muriatic acid. It is a violent poison.

- Hy-dro-gen** (*hy'dro-jen*) (Gr. *hudor*, water, and *gainen*, to generate), a light, colorless gas. When ignited it unites with oxygen to form water.
- Hygiene** (*hy'ji-een*) (Gr. *hugieinos*, healthy), the science which tells how to keep living bodies in good working order.
- Hy-po-der'mic injection** (Gr. *hupo*, under, and *derma*, skin), the introduction of a solution under the skin by means of a hollow needle and syringe. The solution fills the lymph spaces and is absorbed into the capillaries or enters the circulation by way of the lymph.
- Hys-te'ri-a**, a nervous disease in which there is great lack of self-control. The sufferer easily gives way to the emotions, and especially to those of sorrow or mirth.
- Il'e-um** (Gr. *eilein*, to twist), the lower half of the small intestine.
- In-ci'sor teeth** (Lat. *incidere*, to cut into), the teeth in front, with which food is bitten into.
- Incus** (*in'kus*) (Lat. *incus*, anvil), the middle bone of the chain in the ear drum, which transmits waves of sound from the drumhead to the inner ear.
- In-fec'tious disease** (Lat. *in*, in, and *facere*, to make), a disease which has for its cause some matter which can multiply and grow when introduced into the body of a healthy man.
- In-flam-ma'tion** (Lat. *in*, in, and *flamma*, a flame), redness, swelling, pain, and increased heat in a part as a result of injury. It is nature's attempt to repair the part. Often it goes on to form matter.
- In-san'i-ty** (Lat. *in*, not, and *sanus*, safe), unsoundness of mind persisting for a considerable time.
- In-spi-ra'tion** (Lat. *in*, in, and *spirare*, to breathe), taking a breath into the lungs.
- In-tem'per-ance** (Lat. *in*, not, and *temperare*, to regulate), gratification of a desire which does not denote a real need of the body.
- In-tes'tine** (Lat. *intus*, within), the long tube in the abdomen in which digestion of food is completed after it leaves the stomach.
- In-tox-i-ca'tion** (Lat. *in*, in, and *toxicum*, poison), great mental excitement or lack of control, usually due to alcohol.
- I'ris** (Gr. *iris*, rainbow), the colored curtain in the eye behind the cornea.
- Jaundice** (*jahn'dis*) (Fr. *jaune*, yellow), yellowness of the skin due to a deficient excretion of bile by the liver.

Je-ju'num (Lat. *jejunus*, empty), the middle portion of the small intestine.

Joint (Lat. *jungere*, to join), the union of two bones.

Kid'ney, the organ which excretes urea.

Lab'y-rinth (Gr. *laburinthos*), an intricate arrangement of passages. The inner ear.

Lach'ry-mal glands (Lat. *lacrima*, a tear), the glands which produce the tears. They are situated in the orbit just above the eyeball, upon its outer side.

Lac'te-al tubes (Lat. *lac*, milk), the fine lymphatic tubes which take up fat from the intestine. During digestion they can be seen as milky lines across the mesentery.

Lac-tom'e-ter (Lat. *lac*, milk, and *metrum*, measure), an instrument for testing the purity of milk.

Larynx (*lah'rinks*) (Gr. *larugx*), the box in the upper part of the neck in which the windpipe begins. It contains the vocal cords.

Lau'da-num, opium dissolved in nine times its weight of alcohol.

Lens (Lat. *lens*, lentil), a transparent substance having curved surfaces. It has the power of changing the directions of rays of light.

Leu-co-ma-ine (*lew-ko'mah-in*) (Gr. *leukoma*, white), a class of substances resembling alkaloids which are found in the body during life. They are very poisonous, and much sickness is due to their presence.

Lev'er (Fr. *lever*, to raise), a pry; a rigid bar, one part of which is made to turn about a fixed point called a fulcrum, while an opposite part presses against a resisting object which it moves.

Lig'a-ment (Lat. *ligare*, to bind), the fibrous bands of connective tissue which bind bones together to form joints.

Liv'er, the large red gland in the upper right side of the abdomen. It forms bile and changes digested food to blood.

Lymph (Lat. *lymp̄ha*, a spring of water), the plasma and white corpuscles which have left the capillaries to nourish the cells of the body.

Lym-phat'ics, the tubes which convey lymph back to the veins. Lymph nodes are spongy bodies like grains of wheat which strain out waste or poisonous substances from the lymph. In the neck and groin they can be felt, and are usually called kernels.

- Ma-la'ri-a** (Ital. *malo*, bad, and *aria*, air), a disease caused by the bite of a certain kind of mosquito.
- Mal'le-us** (Lat. *malleus*, hammer), the first bone of the chain of small bones which conveys sound waves across the tympanum.
- Malt**, grain, usually barley, soaked in water until it has sprouted about half an inch, and then dried. The sprouting changes a large part of the starch to sugar.
- Ma'ni-a** (Lat. *mania*, rage), a form of insanity in which the intellect is so active that the judgment cannot control it.
- Mar'row**, fat which fills the hollow bones.
- Mas-ti-ca'tion** (Lat. *masticare*, to chew), properly, the grinding to which food is subjected by the teeth, tongue, and lips. Usually the mixing with the saliva is also included.
- Mas'toid process** (Gr. *mastos*, the breast), the rounded projection of bone situated behind the ear.
- Me-dul'la oblongata** (Lat. *medulla*, marrow), the part of the brain just above the spinal cord. It controls respiration and the contraction of arteries.
- Mel-an-cho'li-a** (Gr. *melas*, black, and *chole*, bile), a form of insanity in which a person's mental actions are excessively retarded. He feels downcast and thinks every one is avoiding him on account of his sins. It is the opposite of mania. It was formerly supposed to be due to black bile circulating in the blood.
- Mem'brane** (Lat. *membrana*, skin), any skin-like part of the body. The membrana tympani is the skin-like tissue which separates the middle ear from the outer ear.
- Mer'cu-ry** (Lat. *Mercurius*, the messenger of the gods), the liquid metal commonly called quicksilver.
- Mes'en-ter-y** (Gr. *mesos*, middle, and *enteron*, intestine), the thin fold of peritoneum which holds the intestine in place.
- Met-a-car'pal bones** (Gr. *meta*, after, and *karpos*, the wrist), the five slender bones just below the wrist which form the palm of the hand.
- Met-a-tar'sal bones** (Gr. *meta*, after, and *tarsos*, the flat of the foot), the five long bones in front of the ankle which form the front part of the foot.
- Mi'crobes** (Gr. *mikros*, little, and *bios*, life), the smallest living being. Microbes are plants, some of which may grow in the human body and produce diseases. They are the same as bacteria and germs.

- Mi'cro-scope** (Gr. *mikros*, little, and *skopein*, to see), an instrument which makes minute objects appear large.
- Milk**, the fluid which all female mammals secrete for the nourishment of their young.
- Mi'tral** (Gr. *mitra*, a head covering), the valve between the left auricle and ventricle; when closed it resembles a priest's miter or hat.
- Mo'lar** (Lat. *mola*, a mill), a tooth having a flat surface for grinding food. The last three teeth on each side of each jaw are molars.
- Mold**, a low order of microscopic plants which usually grow in the interior of substances. Common forms send up spore stalks which form the velvety coating popularly called mold.
- Mor-phine'** (Gr. *morpheus*, the god of sleep), the principal alkaloid of opium.
- Mo'tor nerves** (Lat. *movere*, to move), the nerves which carry orders from the brain or spinal cord to cause the cells of the body to act.
- Mu'cous mem'brane**, the soft, skin-like membrane lining cavities which open upon the surface of the body.
- Mu'cus** (Lat. *mucus*), the thin, slimy fluid produced by the epithelium lining the organs of digestion and respiration.
- Mu-ri-at'ic acid** (Lat. *muria*, brine), the common name of hydrochloric acid. The acid is very sour and corrosive. It combines with sodium to form common salt, but many of its combinations are poisonous.
- Mus'cle** (Lat. *musculus*, a little mouse), a collection of cells which can become thicker and shorter and so produce motion.
- Nar-cot'ic** (Gr. *narkoun*, to benumb), a substance which hinders the action of nerves and nerve cells and produces sleep.
- Na'sal duct** (Lat. *nasa*, the nose), the duct which carries tears from the eyes to the nose.
- Nerve** (Gr. *neuron*, nerve), a collection of the threads which conduct impulses between the cells of the body and the central nervous system.
- Neuritis** (*new-ri'tis*) (Gr. *neuron*, nerve), inflammation of a nerve.
- Neu'tral-ize** (Lat. *neuter*, neither), to make neither acid nor alkaline.
- Nic'o-tine**, the active principle in tobacco, named from the Frenchman Nicot who introduced tobacco into France in 1560.
- Nu'cle-o albumin**, a form of albumin containing iron and found in the nucleus of cells. From it hemoglobin is formed.

- Nu'cle-us** (Lat. *nucleus*, kernel), a mass usually distinguishable near the center of each cell. It seems to be endowed with special vital powers.
- Oc-cip'i-tal region** (Lat. *ob*, against, and *caput*, the head), the region of the skull or brain which is situated farthest back.
- O-le-o-mar'ga-rine**, a compound made from beef fat and milk. It has the properties and nutritive value of butter.
- Ol-fac'to-ry** (Lat. *olere*, to have a smell, and *facere*, to make), pertaining to the sense of smell.
- O-men'tum** (Lat. *omentum*), the fatty apron in front of the intestine.
- O'pi-um** (Gr. *opion*, poppy juice), the dried juice of a kind of poppy growing in western Asia. It is a narcotic and is used to produce sleep and to benumb pain.
- Op'tic** (Gr. *optikos*), pertaining to sight. The optic nerves convey impressions of sight. The optic tubercles are collections of gray matter in the brain between the medulla and cerebrum. They are reflex centers for the eye.
- Or'bit** (Lat. *orbis*, a circle), the bony cavity which contains the eyeball.
- Or'gan** (Gr. *organon*, a tool), a collection of tissues having a definite compact form and purpose.
- Or-gan'ic** (Gr. *organon*, a tool), a term designating a substance built up only by the agency of living substances.
- Ox-i-da'tion**, the union of oxygen with another substance. It is the essential part of the processes of burning and of breathing.
- Oxygen** (*ox'y-jen*) (Gr. *oxus*, sharp or acid, and *genein*, to generate), a gas forming one fifth of the air. Its union with the cells of the body forms the essential part of the process of breathing.
- O'zone** (Gr. *ozon*, smelling), a very active form of oxygen formed by electricity and sometimes found in the air.
- Pal'ate** (Lat. *palatum*), the roof of the mouth.
- Pal-pi-ta'tion** (Lat. *palpitare*, to throb), violent throbbing of the heart, so that its beats make themselves felt through the chest wall.
- Pan'cre-as** (Gr. *pan*, all, and *kreas*, flesh), the gland situated behind the stomach which forms the pancreatic juice. The sweetbread.
- Pan-cre-at'ic juice**, the liquid secretion of the pancreas which digests albumin, fat, and sugar in the intestine.

- Pan'ic** (Gr. *to panikon*, from *Pan*, the god of the woods, and of sudden fear), a sudden and infectious fear which sometimes seizes upon a crowd.
- Pa-pil'la** (Lat. *papilla*, pimple), a minute projection of the true skin into the epidermis. It contains the endings of the nerves of touch.
- Pa-ral'y-sis** (Gr. *para*, beside, and *luain*, to loosen), lack of action of a part due usually to a failure of the motor nerves to bring the impulses for action.
- Par-e-gor'ic** (Gr. *paregoros*, soothing), a sweet-tasting mixture containing opium and used chiefly in quieting children.
- Pa-ri'e-tal bones** (Lat. *paries*, a wall), the top and sides of the skull.
- Pa-ro'tid glands** (Gr. *para*, near, and *ous*, ear), the salivary glands in the front of the ear.
- Pel'vis** (Lat. *pelvis*, basin), the massive ring of bone which forms the hips. Its cavity is somewhat larger than a large tea cup and contains some of the intestine.
- Pep'sin** (Gr. *peptein*, to cook or digest), a lifeless ferment found in the stomach of all animals. It digests albumin.
- Pep'tone** (Gr. *peptos*, cooked), the form to which albumin is changed by digestion.
- Per-i-car'di-um** (Gr. *peri*, around, and *kardia*, heart), the thin bag which surrounds the heart.
- Per-i-os'te-um** (Gr. *peri*, around, and *osteon*, bone), the thin, tough membrane which covers bone, reproduces its cells, and transmits its blood vessels and nerves.
- Per-i-stal'sis** (Gr. *peri*, around, and *stellein*, to arrange), the regular, worm-like movements of the alimentary canal, which force its contents onward.
- Per-i-to-ne'um** (Gr. *peri*, around, and *teinein*, to stretch), the thin, shining membrane which lines the interior of the abdomen and covers its organs.
- Per-spi-ra'tion** (Lat. *per*, through, and *spirare*, to breathe), the watery secretion of the skin. The sweat.
- Pha-lan'ges** (Gr. *phalagx*, a rank of soldiers), the rows of bone which form the fingers and toes. Its singular is *phalanx*.
- Pharynx** (*far'inks*) (Gr. *pharugx*, the throat, from *pharein*, to cleave), the cavity back of the nose and mouth.

- Phos'phor-us** (Gr. *phos*, light, and *pherein*, to bring), a waxy, yellowish substance which combines with oxygen at ordinary temperatures, giving off heat and a faint light. The light produced by rubbing matches is due to the phosphorus.
- Phys-i-ol'o-gy** (Gr. *phusis*, nature, and *logos*, discourse), the science which tells of the working of living bodies.
- Pi-a ma-ter** (Lat. *pia*, pious, and *mater*, mother), the delicate covering of the brain which carries its blood vessels, in distinction from the thick protecting *dura mater*.
- Plas'ma** (Gr. *plasma*, molded), the liquid part of blood in distinction from the cells which float in it. It is composed chiefly of water, albumin, and minerals. It is food for the cells of the body and it washes away their waste matters.
- Pleura** (*plew'ra*) (Gr. *pleura*, rib), the lining of the chest and coating of the lung.
- Plex'us** (Lat. *plectere*, to braid), a network of sympathetic nerve cells and fibers.
- Plumb'ing** (Lat. *plumbum*, lead), the pipes which conduct water and sewage in a house. Many are made of lead.
- Pneumonia** (*new-mo'ni-a*) (Gr. *pneumon*, a lung), a disease in which the air sacs of the lung become filled with coagulated matters from the blood.
- Poi'son** (Lat. *potio*, a drink), a substance which destroys or interferes with the life of the cells, when it is taken into the body.
- Por'tal vein** (Lat. *porta*, a gate), the vein formed by the union of the veins from the digestive organs. This vein divides into the capillaries of the liver. Finally three veins conduct the blood to the ascending vena cava.
- Pro'to-plasm** (Gr. *protos*, first, and *plasma*, form), the albuminous substance which forms the body of every living cell.
- Proximate principles**, the elementary substances existing as such in the body.
- Ptomaine** (*to'mah-in*) (Gr. *ptoma*, a dead body), a class of poisonous substances resembling alkaloids and leucomaines, which are found in dead bodies. Their presence makes decayed food dangerous.
- Ptyalin** (*ti'a-lin*) (Gr. *ptuein*, to spit), the lifeless ferment in the saliva which changes starch to sugar.
- Pul'mo-na-ry** (Lat. *pulmo*, lung), pertaining to the lungs.

- Pulse** (Lat. *pulsus*, a blow), the wave which may be felt in an artery with each heart beat.
- Pu'pil** (Lat. *pupilla*), the opening in the iris through which light enters the eye. It appears as a round black spot in the center of the colored part of the eye.
- Pus** (Lat. *puteo*, to rot), the creamy matter which flows from an abscess. It is formed mostly of dead white blood cells.
- Pu-tre-fac'tion** (Lat. *putris*, rotten, and *facere*, to make), the process of decay accompanied by bad odors.
- Py-lo'rus** (Gr. *pule*, a gate), the orifice in the right end of the stomach, through which food passes into the intestine.
- Py'ri-dine** (Gr. *pur*, fire), a poisonous substance formed by burning nicotine.
- Ra'di-us** (Lat. *radius*, the spoke of a wheel), the bone upon the thumb side of the arm, below the elbow.
- Re'flex action** (Lat. *re*, back, and *flectere*, to turn), the action of the central nerve cells in sending orders for motion in response to an impulse brought by sensory nerves.
- Ren'nin**, a lifeless ferment extracted from the lining of the fourth stomach of a calf, and used to curdle milk in cheese making. The same ferment is found in the human stomach, especially in infancy.
- Res-pi-ra'tion** (Lat. *re*, again, and *spirare*, to breathe), the process of breathing and of the interchange of oxygen and carbonic acid gas in the cells of the body.
- Ret'i-na** (Lat. *rete*, a net), the inner lining of the eye in which the nerves of sight end.
- Rheumatism** (*ru'ma-tism*) (Gr. *rheum*, a flowing or stream), a swelling of the joints in which they are often quickly affected one after another. Usually it is due to fluid collecting in the bag of the synovial membrane.
- Rick'ets**, a disease in which the bones have too little lime and bend too easily.
- Sa'crum** (Lat. *sacer*, sacred, for the bone was offered in sacrifice), the part of the backbone which completes the pelvis behind.
- Sa-li'va** (Lat. *saliva*; Gr. *sialon*, spittle), the watery fluid in the mouth.

- Sa-pon-i-fi-ca'tion** (Lat. *sapo*, soap, and *facere*, to make), the process of making soap. Commonly the name soap is applied only to the combination of soda or potash with the acid part of fat. But lime, or magnesium, or other metal may take the place of soda or potash, as it does when hard water and soap are used to wash the hands. The lime soap which is formed feels sticky and rough, and does not dissolve in water, but forms a white scum on the surface.
- Scap-u-la** (Lat. *scapulae*, the shoulder blades), the flat bone upon the back behind the shoulder. The shoulder blade.
- Sciatica** (*si-at'i-ka*) (Gr. *ischiadikos*, pertaining to the hip), a painful inflammation of the main nerve of the leg which begins just behind the hip joint.
- Sclerotic** (*skler-ot'ic*) (Gr. *skleros*, hard), the tough outer covering of the eyeball.
- Scur'vy**, the disease caused by lack of variety of food. It consists of pain and of bleeding under the skin, especially of the legs and gums.
- Sebaceous glands** (*se-ba'shus*) (Lat. *sebum*, fat), the glands in the skin which secrete oil.
- Se-cre'tion** (Lat. *secretus*, separated), a substance which is separated from the blood by the epithelium of glands and used by the body.
- Sem-i-cir'cu-lar canals**, the three tunnels in the inner ear in which there are nerves whose duty is to take note of the position of the body in balancing itself.
- Sem-i-lu'nar valves**, three half-moon-shaped valves at the beginning both of the aorta and of the pulmonary artery. They prevent blood from flowing back to the heart.
- Sen-sa'tion** (Lat. *sentire*, to feel), a conscious impression made upon the brain by an impulse brought by a sensory nerve.
- Sen'so-ry nerves** (Lat. *sentire*, to feel), nerves which carry impulses from the cells to the central nervous system.
- Se'rous membrane**, the thin membrane lining the cavities of the body which do not connect with its surface. It is named from the fluid, like serum, which forms in it in a quantity just sufficient for lubrication.
- Se'rum** (Lat. *serum*, the watery part of curdled milk), the straw-colored liquid which separates from a blood clot.
- Sewer** (*su'er*), an underground tunnel for carrying slops from the houses of a town.
- Si'nus** (Lat. *sinus*, curve), a cavity.

- Skel'e-ton** (Gr. *skellein*, to dry), the bones of the body.
- So-lu'tion** (Lat. *solutus*, dissolved), a liquid mixture in which the ingredients are not changed in essential properties.
- Speech**, the expression of thoughts by words.
- Spine** (Lat. *spina*, the backbone), the backbone.
- Spleen** (Gr. *splen*), a soft, red organ lying to the left of the stomach. Its use is probably to form the red blood cells.
- Spore** (Gr. *spora*, seed), a reproductive cell of a flowerless plant. Spores are extremely minute, and some are capable of resisting influences which are fatal to most other forms of life.
- Stapes** (Lat. *stapes*, stirrup), the third bone in the chain of bones which conducts sound from the membrana tympani to the inner ear.
- Starch** (Anglo-Saxon, *stearc*, strong), a food substance composed of carbon, hydrogen, and oxygen. It is the first recognizable form through which organic substances pass as they are built up by plants. In the body it is changed to sugar.
- Ste-ap'sin** (Gr. *stear*, suet), the ferment of the pancreatic juice which digests fat.
- Ster'il-ize** (Lat. *sterilis*, without power to produce seed), to destroy bacteria and their spores as by heat or chemicals. It is usually applied to the preparation of surgical dressings.
- Ster'num** (Gr. *sternon*, the breast), the flat bone which extends down the front of the breast; the breast bone.
- Stim'u-lant** (Lat. *stimulus*, a whip), a substance which excites a part to action without increasing its supply of energy.
- Stomach** (*stum'ak*) (Gr. *stoma*, a mouth or entrance), the muscular bag into which food enters when swallowed, and which begins the work of digestion.
- Strych'nine** (Gr. *struchnos*, a kind of shrub), a substance obtained from the seeds of the struchnos shrub. It is used to increase the power of the nervous system; in overdoses it produces violent convulsions.
- Sub-lin'gual glands** (Lat. *sub*, under, and *lingua*, tongue), the two salivary glands under the front part of the tongue.
- Sub-max'il-la-ry gland** (Lat. *sub*, under, and *maxilla*, jaw), the salivary gland situated under the side of the lower jaw.
- Su'gar** (Lat. *saccharum*, sugar), a sweet substance composed of carbon, hydrogen, and oxygen in nearly the same proportions as in starch. There are many varieties, but during digestion all are changed to glucose or grape sugar. It gives heat to the body.

- Syl'vi-an fissure**, the deep fissure extending backward upon each side of the brain. It was named after the French physician Sylvius, who died in 1555.
- Sym-pa-thet'ic system**, the collection of nerve cells and nerves which control the preparation of food and its distribution to the cells. It is subordinate to the spinal cord.
- Syn-o'vi-a**, the fluid which lubricates the movable joints.
- Syn-o'vi-al membrane**, the membrane lining the movable joints.
- Sys'tem** (Gr. *sunistanai*, to place together), a series of tissues and organs, working together for a definite purpose.
- Sys'to-le** (Gr. *sun*, together, and *stellein*, to set), the contraction of the heart forcing blood into the arteries of the body.
- Tan'nin** (Fr. *tan*, originally meaning oak), an acid found in the barks of most trees, and used to toughen and harden skins into leather.
- Tape worm**, a kind of worm inhabiting the intestine. It resembles a long piece of white tape.
- Tar'sal bones** (Gr. *tarsos*, the sole of the foot), the seven irregularly shaped bones in the hinder half of the foot.
- Tar'tar**, a kind of hard, brown substance which often forms upon the teeth.
- Tau-ro-chol'ic acid**, one of the waste substances in the bile.
- Tem'po-ral** (Lat. *tempora*, the temples), pertaining to the regions of the skull in the neighborhood of the ears.
- Ten'don** (Lat. *tendere*, to stretch), a strong white cord, one end of which is attached to a muscle above a joint, and the other to a bone or to flesh below a joint.
- Thoracic duct**, the tube running upward upon the backbone and conveying lymph to the veins.
- Tho'rax** (Gr. *thorax*, breastplate), the cavity of the body under the ribs.
- Thy'roid** (Gr. *thureos*, a shield, and *eidōs*, form). The large folded cartilage which forms the principal part of the larynx.
- Tib'i-a** (Lat. *tibia*), the shin bone.
- Tissue** (*tī'shu*), a group of cells or fibers alike in form and action.
- To-bac'co** (West Indian *tabaco*, the name of the pipe used in smoking), a narcotic plant used for smoking and for chewing.
- Ton'sil** (Lat. *tonsilla*), a round body situated one on each side of the throat in front of the pharynx. They have no special use. Sometimes they become enlarged, and need to be removed.

- Tox'in** (Gr. *toxikon*, arrow poison), a virulent poison formed within a living body. Most toxins are ptomaines.
- Tra'che-a** (Gr. *trachus*, rough), the windpipe; rings of cartilage make its outside irregular and rough.
- Trans-fu'sion** (Lat. *trans*, across, and *fundere*, to pour out), transferring blood from the veins of one person into the veins of another.
- Tri'ceps** (Lat. *tri*, three, and *caput*, head), the muscle extending down the back of the arm from the shoulder to the elbow. It straightens the elbow. Its upper end has three branches.
- Trichinae** (*trick-i'nee*) (Gr. *thrix*, a hair), microscopic worms which live in the muscles of a pig. They sometimes remain alive in partially cooked pork, and if eaten produce a deadly disease.
- Tri-cus'pid valve** (Lat. *tres*, three, and *cuspis*, point), the valve between the right auricle and ventricle; it is formed of three leaves.
- Tryp-sin** (Gr. *tribein*, to rub), the ferment of the pancreatic juice which digests albumin.
- Tu-ber-cu-lo'sis** (Lat. *tuberculum*, a little lump), a disease in which small white lumps like pinheads form in the flesh. Later, these soften and run out as matter. The disease is commonly called consumption.
- Tym'pa-num** (Lat. *tympanum*, drum), the middle ear.
- Ty'phoid fever** (Gr. *tuphos*, a cloud, and hence a stupor arising from fever, and *eidos*, form), a tedious and weakening fever caused by the growth of a kind of bacteria.
- Ty-ro-tox'i-con** (Gr. *tuross*, cheese, and *toxicon*, poison), a virulent ptomaine poison sometimes found in cheese and other substances made from milk.
- Ul'na** (Lat. *ulna*, the elbow), the bone on the little finger side of the lower arm.
- U're-a** (Gr. *ouron*, urine), a very soluble crystalline substance, one of the three principal waste products of the body. It is the essential part of urine.
- U-re'ter** (Gr. *ouron*, urine), the tube leading from the kidney to the bladder.
- Vac-cin-a'tion** (Lat. *vacca*, a cow), the introduction of the germs of cowpox into the skin for the purpose of causing the disease as a protection against smallpox.

- Valv'u-læ con-ni-ven'tes** (Lat. *valvulae*, little sliding doors, and *conni-ventes*, winking), deep puckers in the mucous membrane of the small intestine.
- Var'i-cose veins** (Lat. *varix*, an enlarged vein), distended and enlarged veins.
- Vas-o-mo'tor nerves** (Lat. *vasa*, a vessel, and *motor*, pertaining to motion), nerves which produce either contraction or dilatation of the arteries.
- Vein** (*vane*) (Lat. *vena*, a vein), a tube which carries blood back to the heart.
- Ven-ti-la'tion** (Lat. *ventilare*, to winnow), changing the air of a room.
- Ven'tri-cle** (Lat. *ventriculus*, stomach), one of the large, thick-walled cavities of the heart.
- Ven-tril'o-quism** (Lat. *venter*, the abdomen, and *loqui*, to speak), speaking so that the voice seems to come from a distance away from the speaker.
- Ver'mi-form ap-pen'dix** (Lat. *vermis*, worm, *appendix*, something added), the closed tube, shaped like an earthworm, which projects from the beginning of the large intestine. In some of the lower animals, as in the hen, it is as large as the other part of the intestine, but in man is only about two inches in length and one eighth inch in diameter.
- Ver'te-bra** (Lat. *vertebra*), a joint of the backbone.
- Vest'i-bule** (Lat. *vestibulum*, a porch or entrance), the cavity of the internal ear from which the cochlea and semicircular canals extend.
- Vil'lus** (Lat. *villus*, a tuft of hair), one of the minute slender projections upon the inner surface of the intestine.
- Vin'e-gar**, a sour liquid made from wine or cider by the oxidation of its alcohol to *acetic acid*, of which it contains from two to four per cent.
- Vit're-ous hu'mor** (Lat. *vitrum*, glass), the jelly-like fluid which fills the eyeball behind the lens.
- X rays**, a form of radiant energy discovered by Roentgen in 1895. It penetrates wood, flesh, and many other substances which are opaque to sunlight.
- Yeast**, a collection of single-celled plants, whose growth changes sugar to alcohol and carbonic acid gas. The agent which causes bread to become light.

INDEX

- Abdomen, 66.
Abscess, 399.
Absorption, 89, 260.
Accommodation, 339.
Achilles' tendon, 374.
Acid, 28, 149.
Aconite, 148, 151.
Adam's apple, 349.
Adenoid vegetations, 193, 327.
Adulteration, of alcohol, 47.
 of coffee, 127.
 of milk, 111.
Air, 206, 220.
 in lungs, 207.
 in clothing, 238.
 moisture in, 236.
 rarefied, 222.
 sacs, 195.
Albumin, 23, 34, 69, 84, 92.
Alcohol, 44, 140.
 effects on arteries, 189.
 brain, 315.
 digestion, 98.
 excretion, 251.
 habit, 319.
 heart, 168.
 heat, 243.
 heredity, 319.
 intestine, 100.
 judgment, 316.
 kidney, 251.
 liver, 100.
 lungs, 213.
 muscle, 377.
 nerves, 273.
 paralysis, 317.
 peristalsis, 99.
 respiration, 214.
 sight, 342.
 stomach, 99.
 voice, 354.
Alimentary canal, 53.
Alkalies, 28, 149.
Alkaloids, 152.
Ameba, 10.
Amylopsin, 84.
Anæsthesia, 146, 223, 320.
Anatomy, 9.
Anemia, 159.
Antidote, 149.
Antimony, 151.
Antiseptics, 387.
Antitoxin, 386, 423.
Antrum, 54, 193, 324.
Aorta, 172.
Apoplexy, 311.
Appendicitis, 80.
Appendix, vermiform, 80.
Appetite, 74.
Aqueous humor, 334.
Argon, 220.
Arsenic, 150.
Arterial blood, 157, 177, 207.
Artery, 163, 172, 187.
Asphyxia, 212.
Assimilation, 91.
Astigmatism, 340.
Auricle, 163.

Bacteria, 384, 410, 411.
Barley, 122.
Bathing, 261.
Beans, 122.
Beard, 261.
Beds, 240.
Beef tea, 115.
Beer, 43.
Belladonna, 152.
Biceps, 375.
Bicuspid tooth, 55.
Bile, 84, 85, 93.
Biliousness, 85, 93.

- Bilirubin, 250.
 Biscuit, 121.
 Bitters, 101.
 Blackheads, 259.
 Bladder, 84, 249.
 Bleeding, 186.
 Blister, 257.
 Blood, 156, 206.
 as food, 117.
 in lower animals, 159.
 poisoning, 389, 424.
 Blowing, 198.
 Boards of health, 405, 413.
 Bones, 357.
 Bowels, regularity of, 94.
 Brain, 289.
 food, 133, 309.
 in lower animals, 300.
 Bread, 43, 121, 122.
 Breathing, 192, 198.
 Bright's disease, 249.
 Broken, back, 281.
 bones, 361.
 Bronchi, 195.
 Bunion, 366.
 Burns, 242.
 Butter, 111.
 Butterine, 112.

 Cæcum, 80.
 Caisson, 222.
 Cake, 121.
 Callus, 257.
 Cancellous bone, 359.
 Canine teeth, 54.
 Cannabis indica, 145.
 Canned food, 42, 125.
 Capillary, 173, 208.
 Carbolic acid, 150, 388.
 Carbon, 33, 36.
 Carbonic acid gas, 33, 206, 208, 223.
 Cardiac, 67.
 Carpal bones, 358.
 Cartilage, 360.
 Caseine, 109.
 Cataract, 340.
 Catarrh, 61.
 Cellar air, 224.
 Cells, 11, 13, 92, 174, 397.
 Cellulose, 26.
 Cement, 55.
 Cerebellum, 292.
 Cerebrum, 293.
 Cesspool, 252, 407.
 Cheeks, 56.
 Cheese, 110.
 Chemical action, 28.
 Chicken pox, 427.
 Chill, 234.
 Chloral, 145.
 Chloride of lime, 388.
 Chloroform, 146, 320.
 Chlorophyll, 35.
 Choking, 199.
 Cholera, 385, 426.
 Choroid coat, 334.
 Chyle, 86.
 Chyme, 69.
 Cigar, 141.
 Cigarette, 142.
 Cilia, 195, 197, 205, 218.
 Circulation, 177.
 in lower animals, 180.
 Clabber, 110.
 Clams, 116.
 Clavicle, 358.
 Clothing, 237.
 Clot, 158.
 Coagulation, 23.
 Coal gas, 225.
 Cocaine, 145.
 Coccyx, 357.
 Cochlea, 326.
 Cocoa, 127.
 Coffee, 126.
 Cold, sensation of, 234.
 feet, 239.
 taking, 185, 400, 420.
 Colon, 80.
 Color, blindness, 337.
 and heat, 238.
 of skin, 257.
 Complexion, 259.
 Condensed milk, 112.
 Congestion, 185, 397.
 Conjunctiva, 336.
 Connective tissue, 11, 38, 398.
 Conservation of energy, 36.
 Consonants, 352.
 Consumption, see Tuberculosis.
 Contagious diseases, 385, 416.
 Contraction of muscles, 373.
 Convulsions of brain, 293.
 Cooking, 51, 123.

- Copper, 150.
 Corn meal, 122.
 Cornea, 335.
 Corns, 257.
 Corpuscles, 156.
 Cotton, 237.
 Coughing, 198.
 Crabs, 117.
 Cranial nerves, 290.
 Cricoid cartilage, 349.
 Crown of tooth, 55.
 Crying, 198.
 Cud, 104.
 Curvature of spine, 366.
 Cuticle, 257.
 Cutis, 256.

 Deafness, 327.
 Decay, 13, 24, 42, 46, 384.
 Decayed food, 152.
 Deglutition, 61.
 Delirium, 311.
 tremens, 318.
 Dentine, 55.
 Derma, 256.
 Diaphragm, 66, 196.
 Diastole of heart, 165.
 Diet list, 132.
 Diffusion, 24.
 Digestion, 51, 104, 108.
 Diphtheria, 385, 416, 420, 422.
 Disease germs, 136, 148, 157, 193, 221,
 226, 248, 251, 385, 410, 416.
 Disease of bone, 361.
 of eye, 341.
 of heart, 167.
 of hip joint, 368.
 of spine, 281.
 Disinfection, 387.
 Dislocations, 367.
 Distillation, 44.
 Dreams, 308.
 Drinking cup, 419.
 Dropsy, 180.
 Drowning, 213.
 Drugs, 148.
 Duodenum, 80.
 Dura mater, 290.
 Dust, 221, 418.
 Dyspepsia, 74, 93.

 Ear, 325.
 wax, 329.

 Ear, in lower animals, 329.
 Eating, 76, 132.
 Eggs, 112.
 Electric shock, 213.
 Emergencies—
 Alcoholic paralysis, 141, 317.
 Apoplexy, 311.
 Asphyxia, 212.
 Bleeding, 186.
 Broken bones, 361.
 Burns, 242.
 Choking, 199.
 Coal gas, 225.
 Cold, taking, 185.
 Contagious diseases, 385.
 Dislocation of bones, 367.
 Drowning, 213.
 Electric shock, 213.
 Fainting, 150, 168.
 Fever, 233, 242, 263.
 Fits, 312.
 Fright, 312.
 Frozen limbs, 241.
 Hysteria, 309.
 Insanity, 310.
 Panics, 312.
 Poisoning, 144, 149.
 Sprains of joints, 367.
 Stings, 154.
 Sunstroke, 236.
 Emulsion, 25.
 Enamel, 55.
 Energy, conservation of, 36.
 source of, 233.
 Epidermis, 257.
 Epiglottis, 61.
 Epilepsy, 312.
 Epithelium, 57, 58, 68, 82, 248, 257,
 261, 271, 398.
 Eruptive diseases, 426.
 Erysipelas, 385, 389, 417.
 Esophagus, 62.
 Ether, 320.
 Eustachian tube, 193, 327.
 Excretion, 248.
 Exercise, 166, 309, 377.
 Expansion of lung, 197.
 Expiration, 196.
 Extensor muscles, 375.
 Eye, 334.
 in lower animals, 344.
 Eyelids, 336.

- Face, 376.
 Fainting, 150, 168.
 Far sight, 339.
 Fat, 25, 34, 91, 209.
 Fatty heart, 167.
 Femur, 358.
 Fermentation, 42, 76, 100, 109.
 Fever, 233, 242, 263, 420. •
 Fibrin, 158.
 Fibula, 359.
 Field of view, 337.
 Filtration, 137, 409; of air, 229.
 Fissures of brain, 293.
 Fish, 116.
 Fits, 312.
 Flat foot, 359.
 Flexor muscles, 375.
 Flies, 411, 426.
 Fluids of body, 15.
 Focus, 18.
 Food, 51, 107, 120, 131, 413.
 Foul air, 223, 421.
 Freckles, 257.
 Frontal region, 294.
 Frozen limbs, 241.
 Fruit, 124.
 Fulcrum, 373.
 Fur, 238.
 Fusel oil, 45.
 Gall bladder, 84.
 Ganglia, 284.
 Gaping, 198.
 Gastric juice, 68.
 Gelatine, 23.
 Germs, see Disease germs.
 Gills, 216.
 Gizzard, 105.
 Gland, 57.
 Glucose, 51, 92.
 Glue, 23.
 Gluten, 120.
 Glycocholic acid, 250.
 Glycogen, 92.
 Goose flesh, 259.
 Gout, 367.
 Grain, 120.
 Gray matter, 276, 290, 292, 293.
 Grippe, 385, 421.
 Habit, 142, 306.
 Hair, 259.
 Hangnail, 261.
 Hasheesh, 145.
 Haversian canals, 360.
 Headache, 95, 340.
 Heart, 162.
 Heat, 34, 233.
 Hemoglobin, 24, 156, 207.
 Hemophilia, 159.
 Hemorrhage, 186.
 Heredity, 306.
 Hibernation, 243.
 Hiccough, 198.
 Hip, 358.
 Hip joint disease, 368.
 Hook-worm disease, 430.
 Humerus, 358.
 Humors, 159.
 Hunchback, 368.
 Hunger, 269.
 Hydrochloric acid, 68.
 Hydrophobia, 429.
 Hygiene, 9, 405.
 Hypodermic injections, 153, 180.
 Hysteria, 309.
 Ileum, 80.
 Illusions, 329, 342.
 Immunity, 416.
 Incisor, 54.
 Incus, 326.
 Indigestion, 73, 93.
 Infectious diseases, 385, 416.
 Inflammation, 397, 424.
 Ingrowing nail, 261.
 Insalivation, 53.
 Insanity, 310.
 Inspiration, 196.
 Instincts, 268.
 Intellect, 299.
 Intemperance in eating, 75, 101, 251.
 Intensity of voice, 351.
 Intestinal juice, 84.
 Intestine, 79, 425.
 Intoxication, 214, 317.
 Iris, 335.
 Iron, 24, 124.
 Itching, 271.
 Ivory, 55.
 Jaundice, 250.
 Jaws, 54.
 Jejunum, 80.
 Joints, 364.

- Kidneys, 249.
 Labyrinth, 325.
 Lachrymal gland, 336.
 Lacing, tight, 200.
 Lacteal, 91.
 Lactometer, 111.
 Larynx, 194, 349.
 Laudanum, 144.
 Laughing, 198.
 Lead, 136, 150.
 Lens, 333.
 Leucomaines, 152.
 Levers, 373.
 Life, 9, 12, 38, 402.
 Ligaments, 365.
 Light, 333.
 Lime, 28.
 Lips, 56.
 Liver, 82, 93, 250.
 Living rooms, 236.
 Lobsters, 117.
 Lockjaw, 417, 429.
 Lungs, 192, 400.
 Lymph, 178.
 Lymphatics, 174, 178.
 Lymph nodes, 178.

 Malaria, 225, 413.
 Malleus, 126.
 Malt, 43.
 Mania, 310.
 Marrow, 160, 359.
 Mastication, 60.
 Mastoid, 327.
 Measles, 416, 419, 427.
 Meat, 113.
 Medulla oblongata, 290.
 Melancholia, 311.
 Membrane, 327.
 Memory, 295, 297.
 Mercury, 150, 388.
 Mesentery, 79.
 Metacarpal bones, 358.
 Metals, 150.
 Metatarsal bones, 359.
 Microbes, 384.
 Microscope, 16.
 Milk, 109.
 Mind, stimulation of, 305.
 Minerals, 27, 33, 51.
 Mitral valve, 164.

 Molar teeth, 55.
 Mold, 383.
 Morphine, 144.
 Mosquitoes, 225, 413.
 Motor, region, 296; center, 278, 296.
 nerves, 271.
 Mouth, 53.
 breathing, 193, 353.
 Mucous membrane, 57.
 Müller's fluid, 72.
 Mumps, 426.
 Muriatic acid, 363.
 Muscles, 366, 371, 376.
 Muscular sense, 271.
 Mushroom, 152.

 Nails, 259.
 Narcotics, 140, 150.
 Nasal duct, 336.
 Near sight, 339.
 Nerve cells, 276.
 Nerves, 266.
 of heart, 166.
 motor, 271.
 sensory, 268.
 sympathetic, 285.
 Nervousness, 309.
 Neuritis, 273.
 Neutralize, 28.
 Nicotine, 141.
 Night air, 225.
 Nose, 192, 324, 420.
 Nucleo-albumin, 24, 126.
 Nucleus, 11, 12, 24.
 Nuts, 125.

 Oatmeal, 122.
 Occipital region, 295.
 Occupation diseases, 221.
 Odors, 224.
 Oleomargarine, 112.
 Olfactory nerves, 325.
 Omentum, 80.
 Opium, 143, 320.
 Optic, nerve, 334.
 tubercles, 292.
 Orbit, 336.
 Organic substances, 37.
 Organs, 16.
 Oxidation, 33, 46, 137, 209, 233, 243.
 Oxygen, 33, 131, 207, 212, 221.
 Oysters, 116.
 Ozone, 220.

- Pain, 270.
 Palate, 53.
 Palpitation of heart, 166, 167.
 Pancakes, 121.
 Pancreas, 82.
 Pancreatic juice, 84.
 Panics, 312.
 Paper clothing, 239.
 Papilla, 258.
 Paralysis, 272.
 Paregoric, 144.
 Parietal region, 294.
 Parotid gland, 59.
 Patella, 359, 375.
 Paunch, 104.
 Peas, 122.
 Pelvis, 358.
 Pepsin, 69.
 Peptone, 24, 69, 92.
 Pericardium, 162.
 Periosteum, 359, 360.
 Peristalsis, 63, 69, 85.
 Peritoneum, 66.
 Perspiration, 235, 248.
 Phalanges, 359.
 Pharynx, 61, 193.
 Phosphorus, 151.
 Physiology, 9.
 Pia mater, 290.
 Pitch of voice, 350.
 Plague, 430.
 Plants and animals, 37.
 Plasma, 157.
 Play, 378.
 Pleura, 196.
 Plexus, 285.
 Plumbing, 253.
 Pneumogastric nerve, 291.
 Pneumonia, 401, 421, 423.
 Poisoning, 149.
 Portal, circulation, 177.
 vein, 92.
 Potash, 28.
 Potatoes, 122.
 Poulitice, 400.
 Protoplasm, 11.
 Proud flesh, 258, 398.
 Proximate principles, 22.
 Ptomaines, 153, 384.
 Ptyalin, 59.
 Public drinking cup, 419.
 Pulmonary circulation, 176.
 Pulse, 173.
 Pupil, 335.
 Purification of air, 230.
 Pus, 399.
 Putrefaction, see Decay.
 Pylorus, 67.
 Pyridine, 142.
 Quality of voice, 351.
 Quarantine, 410, 422, 426.
 Rabies, 429.
 Radius, 358.
 Reaction of bath, 262.
 Reconstruction after oxidation, 35.
 Red blood cells, 157.
 Reflex action, 278.
 Regions of brain, 294.
 Rennin, 69.
 Repair, of injuries, 397.
 in blood tubes, 188.
 in nerves, 273.
 Respiration, 175, 192, 208, 217.
 artificial, 202.
 in lower animals, 215.
 Respiratory center, 201, 211, 291.
 Retina, 334.
 exhaustion of, 337.
 Rheumatism, 367.
 Ribs, 357.
 Rice, 122.
 Rickets, 361.
 Ringworm, 384.
 Root beer, 48.
 Round shoulders, 377.
 Rumen, 104.
 Sacrum, 357.
 Saliva, 59.
 Salt, 27.
 Sanitation, 405.
 Saponification, 26, 85.
 Scapula, 358.
 Scar, 398.
 Scarlet fever, 416, 427.
 Sciatica, 273.
 Sclerotic coat, 334.
 Scrofula, 179, 392.
 Scurvy, 126.
 Seasonings, 126.
 Sebaceous glands, 259.
 Secretion, 58, 272.
 Semicircular canals, 326.

- Semilunar valve, 164.
 Sensation, 268.
 Sensibilities, 299.
 Sensory regions, 295.
 Serous membrane, 67.
 Serum, 158.
 Sewage, 251, 406, 417, 426.
 Sewer, 252, 407.
 Sewer gas, 224, 252.
 Shortness of breath, 211.
 Sick room, 388.
 Sighing, 199.
 Sight, 335.
 Silk, 238.
 Silver, 150.
 Sinus, 324.
 Site for house, 253.
 Skeleton, 357.
 Skin, 256.
 grafting, 258.
 Sleep, 307.
 Smallpox, 416, 417, 427.
 Smell, 325.
 Smoking, 141.
 Smothering, 199.
 Snake bites, 153.
 Sneezing, 198.
 Snoring, 198.
 Snuff, 142.
 Soap, 26.
 Sobbing, 198.
 Soda, 28.
 Solar plexus, 285.
 Solution, 22.
 Sounds, of heart, 166.
 of breathing, 198.
 Soup, 115.
 Specimens, 19, 72.
 Speech, 297, 351.
 Spinal, column, 357.
 cord, 276.
 nerves, 277.
 Spitting, 199.
 Spleen, 160.
 Spores, 383.
 Sprains, 367.
 Standing, 375.
 Stapes, 326.
 Starch, 26, 35, 84.
 Starvation, 133.
 Steapsin, 85.
 Sterilization, 387.
 Sternum, 357.
 Stimulants, 126, 168.
 Stings, 154.
 Stomach, 67.
 Strychnine, 150.
 Subcutaneous tissue, 256.
 Sublingual gland, 59.
 Submaxillary gland, 59.
 Sucking, 199.
 Suffocation, 199.
 Sugar, 26, 35, 132, 209.
 Summer complaint, 110.
 Sun in plant growth, 36.
 Sunstroke, 236.
 Swallowing, 62.
 Sylvian fissure, 293.
 Sympathetic system, 284.
 Synovial membrane, 365.
 Systems, 16.
 Systole of heart, 165.
 Tannin, 127.
 Tapeworm, 117.
 Tarsal bones, 359.
 Tartar, 56.
 Taste, 74, 323.
 Taurocholic acid, 250.
 Tea, 126.
 Tears, 336.
 Teeth, 54.
 Temperance drinks, 48.
 Temperature, of body, 233.
 in lower animals, 243.
 sense, 234, 270.
 Temporal region, 294.
 Tendon, 372.
 Tetanus, 429.
 Thirst, 47, 269.
 Thoracic duct, 91, 179.
 Thorax, 196.
 Thought regions, 297.
 Thyroid cartilage, 349.
 Tibia, 359.
 Tickling, 271.
 Tissues, 14.
 Tobacco, 141.
 effects on brain, 319.
 heart, 169.
 lungs, 215.
 sight, 342.
 smell, 325.
 voice, 353.

- Tongue, 57, 352.
 Tonsil, 193, 422.
 Touch, 269, 323.
 Toxins, 384.
 Trachea, 194.
 Triceps, 375.
 Trichinæ, 117.
 Tricuspid valve, 164.
 Trypsin, 84.
 Tuberculosis, 117, 226, 368, 389, 424.
 Tusk, 55.
 Tympanum, 327.
 Typhoid fever, 110, 385, 420, 425.
 Tyrotoxin, 153.
- Ulna, 358.
 Unconscious mind action, 307.
 Urea, 34, 248.
 Ureter, 249.
 Urine, 249.
- Vaccination, 387, 417, 428.
 Vagus nerve, 291.
 Valves of heart, 164.
 Valvulæ conniventes, 81.
 Varicose veins, 189.
 Vasomotor, center, 291.
 nerves, 185.
 Vegetables, 124.
 Veins, 163, 175.
 Venous blood, 157, 177.
- Ventilation, 226.
 Ventricle, of brain, 294.
 of heart, 163.
 Ventriloquism, 341.
 Vermiform appendix, 80.
 Vertebra, 357.
 Vestibule, 325.
 Villi, 81.
 Vinegar, 41.
 Vitreous humor, 334.
 Vocal cords, 350.
 exercise, 353.
 Voice, 194, 349.
 Vowels, 352.
- Walking, 376.
 Wart, 258.
 Water, 22, 33, 135, 408, 425.
 White blood cells, 157, 174, 386, 397.
 matter, 276, 290, 293.
 swelling, 368.
 Whooping cough, 424.
 Will, 299.
 Wine, 44.
 Wood, 26, 38.
 Wool, 237.
- X rays, 342.
- Yawning, 198.
 Yeast, 41, 382.



any stone acid will furnish hydrogen in
which numerous parts of oxygen & form

Nial

422.5

