

EX LIBRIS

THE PORTLAND CEMENT INDUSTRY

A Practical Treatise

ON

THE BUILDING, EQUIPPING, AND ECONOMICAL RUNNING
OF A PORTLAND CEMENT PLANT

WITH

NOTES ON PHYSICAL TESTING

BY

WILLIAM ALDEN BROWN

ASSOC. AM. SOC. C.E.;

MEMBER SOUTH WALES INSTITUTE OF ENGINEERS;

formerly

ASSISTANT SUPERINTENDENT COWELL PORTLAND CEMENT COMPANY, COWELL, CALIFORNIA,
U.S.A.; WORKS MANAGER BURHAM PORTLAND CEMENT COMPANY (ASSOCIATED
PORTLAND CEMENT MANUFACTURERS); WORKS MANAGER ABERTHAW AND
BRISTOL CHANNEL PORTLAND CEMENT COMPANY, SOUTH WALES



NEW YORK
D. VAN NOSTRAND COMPANY
25 PARK PLACE
1917

THE PATENT OFFICE

747883

T 7883
B7

500000 1000000 5

THE PATENT OFFICE
TRADE MARK REGISTERED

TRADE MARK REGISTERED

PRINTED BY STEPHEN AUSTIN AND SONS, LIMITED,
HERTFORD, ENGLAND.

TRADE MARK REGISTERED



TRADE MARK REGISTERED
THE PATENT OFFICE
TRADE MARK REGISTERED

PREFACE

AFTER this terrible War is over, in which we are fighting for the highest conception of humanity, "Right against Might," and our efforts, combined with those of our gallant Allies, have been crowned with success, the industrial war with our trade competitors will dominate and express our national needs. We shall assuredly suffer crushing commercial defeat if advantage is not taken by British manufacturers to study, adopt, and improve methods of economical production which our rivals have long practised. Neglect, delay, or failure in the attempt will lose to Great Britain the markets of the world for Portland Cement.

It is imperative that we should view with detachment the methods of our fathers if we are to be free to rise to the heights of modern practices, and to strive for the mastery in the perfection and dominion of our products.

Let us not sit in our office chairs bemoaning our fate and consenting to our trade passing to other countries, but let us get busy in our industrial departments, and to order add progress. For the cement manufacturer the immediate future has immense potentialities.

Much time and pains have been given to ensure accuracy in this treatise, to divest it of scientific technicalities, and to present a clear, simple, and realistic description of the actual and economical manufacture of a building material which is of fundamental and supreme importance.

I acknowledge indebtedness to the Council of the South Wales Institute of Engineers for permission to include from their Proceedings, vol. xxxi, No. 4, my "Notes on the subject of Testing Portland Cement"; to Mr. H. R. Cox, M.C.I., for kindred matter; and to Mr. J. A. Towers for data on Power Plants.

WILLIAM ALDEN BROWN.

RHOOSE, GLAMORGAN.

SUMMARY OF CONTENTS

PREFACE

CHAPTER I

INTRODUCTORY

Portland Cement an important Extractive Industry—The Relative Positions of Great Britain, United States of America, and Germany—Pre-eminence of the United States of America—Great Britain's need to "wake up"—State Assistance required to promote and organize Scientific Research—Machinery now manufactured in Great Britain—Inventions—Transitory Period in Manufacture and Mistakes made.

CHAPTER II

HISTORICAL

Lime as a Binding Agent—John Smeaton and Building of Eddystone Lighthouse, 1756 — James Parker's Patent, 1796 — James Frost's Patent, 1822 — Joseph Aspdin's Patent, 1824 — His first Factory, 1825 — Major-General Sir C. W. Pasley's Experiments, 1826 — W. B. Elkinson patented Concrete, 1854—Brunel used Cement for construction of Thames Tunnel, 1828—Sir Robert Peel proposes Tax on Roman Cement, 1845—Brunel's testimony as to Uniformity of Roman Cement, 1839—Robert Stephenson's Testimony in 1843—Great Exhibition, 1851, gave impetus to the Industry—Mr. John Grant in 1859 uses Portland Cement for London Drainage Canal—Growth of the Industry on Thames and Medway—First British Standard Specification, 1904.

CHAPTER III

DEVELOPMENT OF THE INDUSTRY

Rapid Growth of the Industry—Future Development—Many Uses for Portland Cement—Concrete Age—Great Engineering Triumphs due to Concrete—Output of Three Leading Countries—United States' Huge Production—Reason of the Supremacy of the United States—Machinery constructed for Improved Manufacture—Great Britain's Position to-day.

CHAPTER IV

MANUFACTURE—RAW MATERIALS

Classification of Materials—Limestone—Chalk—Marl—Alkali Waste—Clayey Limestone—Clay—Shale—Blast Furnace Slag—Proportioning the Raw Materials—Synopsis—From Raw Material to Portland Cement—Composition and Manufacture of Cement—Processes of Manufacture.

CHAPTER V

DESIGN AND CONSTRUCTION OF A MODERN PORTLAND CEMENT PLANT

Investigation by Investors—Capacity corresponding to Capital Invested—Importance of Consulting Engineers engaged possessing a thorough practical knowledge of the Industry—Site—Raw Materials—Survey of Quarry—Rail and Water Communication—Size of Plant—Simplicity of Design—Machinery to be Installed—Quarry Practice—Big Hole Blasting Drills—Storage of Raw Materials—Crushing and Grinding the Raw Materials—Crushing—General Principles—Types of Crushers—Grinding—Ball and Tube Mills—Centrifugal Mills—Griffin Mills—Fuller-Lehigh Mills—Ring-Roll Mill—Capacity of various Machines used for Crushing, Grinding, and Conveying.

CHAPTER VI

THE ROTARY KILN

Development—Construction—Kiln Lining—Advantages of the Rotary Kiln—Fuel—Coal—Storage—Crushing—Grinding—Crude Oil—Natural Gas—Producer Gas—Cooling—Storing and Grinding the Clinker—Dust Collectors.

CHAPTER VII

POWER PLANTS

Types of Transmission—Water Supply—Type of Power Plant—Choice of Power Units—Boiler Plant—Feed Pumps—Steam and Feed-water Pipes—Superheaters.

CHAPTER VIII

MISCELLANEOUS

Storing and Packing the Cement—Cement Storehouses—Packing—Wooden Barrels—Steel Drums—Sacks—Mechanical Equipment—Equipment for Machine Shop—Smithy—Carpenters and Wheelwrights.

CHAPTER IX

COSTS AND STATISTICS

COSTS OF THE MANUFACTURE OF PORTLAND CEMENT

Cost of Building and Equipping a Modern Portland Cement Plant—Approximate Real Investment in Portland Cement Plants in the United States—Labour Cost per Ton of Cement—Supplies—Cement Productions and Shipments in the United States during 1913 and 1914—Average Factory Price per Barrel—Systematic Cost Keeping—Daily Reports—Wages Analysis—Stores Analysis—Cost Sheet.

CHAPTER X

EQUIPMENT

Mechanical Equipment of some Modern Portland Cement Plants erected during the last five years.

PHYSICAL TESTING

CHAPTER XI

DEVELOPMENT OF CEMENT TESTING

General Notes on Gauging Cement—Tests of Cement required for Immediate Use—Comparative Table of English with Metrical Stresses—Comparative Table of English and Metric Measures—Comparative Table of English and Metric Weights.

CHAPTER XII

CHEMICAL COMPOSITION

Standard Specification—Specific Gravity—Tests of little value alone—Standard Specification—Procedure—Personal Equation.

CHAPTER XIII

FINENESS

Standard Specification—Procedure—Observations on Fineness—Influence on Fine Grinding of Cement upon its Setting Time—Showing Effect of Fine Grinding of Cement on Soundness—Showing Increase in Sand Strength due to Fine Grinding—Personal Equation.

CHAPTER XIV

TENSILE STRENGTH

Standard Specification—Neat Cement—Cement and Sand—Procedure—Testing Neat Cement—Testing Cement with Three Times its Volume of Sand—Proportion of Water for Gauging Sand Briquettes—General Notes.

CHAPTER XV

TIME OF SETTING

Standard Specification—Procedure—Effect of Storage on its Setting Properties—Influence of various Percentages of Water used to gauge the Pats on the Setting Time—Influence of Temperature on the Rate of Setting—Influence of Ageing on the Set—Showing the Effect of Plaster of Paris on the Setting—The Effect of Gypsum on the Setting Time—The Effect of Dead Burned Gypsum on the Setting Time—Personal Equation.

CHAPTER XVI

SOUNDNESS OR CONSTANCY OF VOLUME

Normal Tests—Accelerated Tests—Standard Specification—Le Chatelier Test—Procedure—Other Tests for Soundness—Faija Test—Deval Test—Boiling Test—Cold Water Pats—Plunge Pat Test—The Bottle Test—Air Pat Test.

LIST OF ILLUSTRATIONS

PLATE	PAGE
I.	Steam Shovel excavating material for a Portland Cement Plant 16
II.	Showing the usefulness of the Crane Navy in quarry work. The machine at the top is removing the top soil or overburden, and the machine in the bottom is excavating the mineral, which in this case is chalk for making cement 16
III.	Cyclone Drill 18
IV.	Big Blast Hole Drills in operation 18
V.	Steam Crane for Circular Coal Storage System (20 ft. gauge, 80 ft. radius, 2 ton bucket, 80,000 tons storage capacity) 20
VI.	Newell's Swinging Jaw Crusher 22
VII.	Gyratory Crusher 22
VIII.	Gyratory Crusher (Sectional View) 22
IX.	{ Reciprocating Jaw Crusher } { Horizontal Roll Crusher } 22
X.	{ Gyratory Crusher } { Gyratory Crusher (Sectional View) } 22
XI.	{ Disc Crusher } { Disc Crusher (Sectional View) } 22
XII.	Battery of Ball Mills (Allis Chalmers Co.) 24
XIII.	Battery of Tube Mills (Allis Chalmers Co.) 24
XIV.	{ Newell's Lion Ball Mill } { Edgar Allen's Tube Mill } 24
XV.	Newell's Chamber Grinding Mill 24
XVI.	Transverse Section of Gates' Ball Mill (Allis Chalmers Co.) 24
XVII.	Riveted Tube Mill 24
XVIII.	Composite Frame Griffin Mill (Sectional View) 26
XIX.	The 40 in. Giant Griffin Mill 26
XX.	Bradley Three-Roll Mill 28
XXI.	The Fuller-Lehigh Pulverizer Mill (42 in. Fan Discharge Type) 30
XXII.	{ Ring-Roll Mill } { Ring-Roll Mill (accessibility) } 32
XXIII.	Ring-Roll Mill (Description and Operation) 32
XXIV.	Ring-Roll (Description and Operation) 32
XXV.	Cement Grinding Unit for Rotary and Chamber Clinker 32

PLATE	PAGE
XXVI. A Double Sturtevant-Newaygo Screen in action	32
XXVII. Edgar Allen's Rotary Kiln	39
XXVIII. Edgar Allen's Rotary Clinker Cooler	41
XXIX. Johnson's Rotary Kiln and Cooler	42
XXX. Intermittent Kiln erected by William Aspdin at Northfleet, Kent	44
XXXI. Battery of Continuous Shaft Kilns	44
XXXII. Newell's Double-Tube Coal Dryer	44
XXXIII. A Battery of Rotary Kilns equipped with Aero Pulverizers	46
XXXIV. Aero Pulverizer	46
XXXV. "Steel Plate" Dust-Collecting Fan	50
XXXVI. {A Six-section Air Filter} {Dust Collector}	50

PHYSICAL TESTING

FIG.		
	Schumann's Apparatus for Specific Gravity	127
	The Vicat Needle	140
	Enlarged view of Needle "A"	141
	Gilmore Needles mounted on Stand	143
	The Le Chatelier Gauge	149
	Faija Soundness Test Apparatus	150
1.	} Showing samples of Test Pats	152
2.		
3.		
4.		
5.		
6.		

CHAPTER I

INTRODUCTORY

THE statistics of the production of Portland Cement, the most important non-metallic constructive material used by the engineer at the present time, show that throughout the world this industry ranks among the first eight extractive industries, being exceeded in importance only by coal, pig iron, petroleum, clay products, copper, gold, and stone.

Although the cement industry has expanded with great rapidity, Great Britain, the home of the industry, has not maintained its position. For a time, now definable, Germany passed it in the race, and now the United States stands as the unrivalled giant of the cement world.

The remarkable results accomplished in the United States are directly due to the untiring efforts and whole-hearted co-operation of the Association of American Portland Cement Manufacturers, formed in 1902, and of the National Association of Cement Users, formed about the same time. These Associations continue to do valuable work for this great industry by promoting and encouraging technical research, statistical committees, uniform specification, and publicity. The best of the knowledge and experience at their command has been placed unselfishly and ungrudgingly at the disposal of all; and this enlightened and progressive policy has been fully justified by the wonderful developments which have ensued. These facts are very significant, and present to the British manufacturer a vitally important lesson, which he would do well to take to heart.

The cement industry in Great Britain to-day affords ample scope for the adoption of new methods and more modern machinery; and a special need exists for additional State assistance for the promotion and organization of scientific research, with a view to increased economy and efficiency in the processes of manufacture.

The author himself has been largely concerned in the modernizing of British cement factories, and up to within a few years most of the machinery came from Germany, as no British firm was prepared entirely to equip works with plant embodying the new designs, although there were firms who could supply certain parts. It is gratifying to note that this unsatisfactory state of things no longer exists; and the author, out of his lengthy experience, can confidently assert that British cement

machinery can now challenge comparison with anything of the kind manufactured in Germany. Much, however, remains to be accomplished in the designing of Portland Cement machinery in this country to bring it to the same standard of efficiency that is now prevailing in the United States, especially where crystalline raw materials are used; and it behoves British cement manufacturers to study closely the American methods of crushing and handling the hard materials.

In the United States the man with ideas receives every encouragement and assistance; consequently, in spite of failures, progress is rapid. In Great Britain, where established procedure is clung to like a fetish, the inventor is apt to be regarded as a 'crank and a nuisance'; at any rate, in a 'soil of greater caution and conservatism his ideas do not so readily take root, and so the industry suffers.

During recent years it has been, and is still, necessary to face a period of transition in the manufacture of Portland Cement. Of necessity, changes have had to be made in power plant in the class of machinery to be installed to suit a particular material, in increasing the output of machines, and in the general lay out, in order to lessen the cost of production. Some have profited by the mistakes of others, some by their own, some by neither. Under-estimation has been a frequent pitfall, and foreign competition has been fierce. It will become increasingly so, and to help his fellow-countrymen to meet it is the desire of the author.

CHAPTER II

HISTORICAL

FROM very earliest times lime has been the fundamental ingredient in cementitious building materials. It is only within the last 150 years, however, that the value of an admixture of argillaceous substances with lime has been fully recognized in the production of a strong, reliable binding agent.

Mr. John Smeaton in 1756, when seeking the most suitable material to use in the building of the Eddystone Lighthouse, demonstrated the fact that limestone containing clay, when burned and ground, possessed the property of hardening under water. It was not until 1791, however, that he published the results of these experiments. Several patent specifications were taken out at various times prior to this. In 1796 a James Parker, described as of "Northfleet in the County of Kent, Gentleman", took out a patent for a "certain cement or terras (trass) to be used in aquatic and other buildings and stucco work", and some years afterwards General Pasley applied to this material the name of "Roman Cement".

The first specification of any great practical importance which appeared for many years afterwards was when in 1822 James Frost obtained a patent for the manufacture of "a new cement or artificial stone", which he designated "British Cement". It may be questioned whether Frost, in drawing up this specification, had a thorough grasp of the chemistry of his subject, as a material free from any admixture of alumina, but containing from 9 to 40 per cent of silica, would probably have poor cementitious properties.

Joseph Aspdin, a bricklayer of Leeds, first gave the name "Portland" to a cement produced according to a specification protected in October, 1824. The name was probably suggested on account of the close resemblance of the product, when set, to the well-known building-stone quarried at Portland on the south coast of Dorsetshire. A noteworthy point in this specification is, that although the process of manufacture as carried out to-day is very different, yet in those early days Aspdin recognized the importance of a thorough amalgamation of his raw materials by mixing them "to a state approaching impalpability".

He does not appear to have calcined his mixture to a point of incipient fusion, as has since been recognized to be necessary, nor does he specify the proportion of raw materials to be used. It is probable that Aspdin, knowing little or nothing of chemistry

and guided only by empirical rules, was able by virtue of his long experience to produce a cement of a fairly reliable character.

In 1825 he established a factory at Wakefield, where he produced this cement. These original works were destroyed when the Lancashire and Yorkshire Railway was constructed, but another was erected on a site not very far from the original works, and this still exists and was working until recently. Aspdin was born in 1779, and died on March 20, 1855.

In 1826 Major-General Sir C. W. Pasley, Lecturer on Architecture, etc., at the Military School at Chatham, after experiments and research work at Chatham Dockyard succeeded in 1830 in producing very good cement from Medway Clay and the chalk found in the neighbourhood.

The more general use of cement in buildings caused factories to be erected for its manufacture in various parts of the country, including works at Faversham, in Kent, by Mr. Samuel Sheppard in 1816; those of Messrs. Francis & White (afterwards Messrs. Francis & Son) at Nine Elms; those of Frosts on the Thames at Swanscombe, Kent; and those of I. C. Johnson at Gateshead. The Gateshead works are interesting from the fact that it was probably with cement from these works that W. B. Elkinson, the Newcastle-on-Tyne plasterer, obtained the experience in making concrete that led him to take out his patent of 1854, under which he covered the construction of reinforced concrete floors and beams.

In the early days of its manufacture Portland Cement appears to have been mainly used for stucco work, but owing to the irregular and uncertain results obtained it was not much in favour with engineers for constructive purposes. As early as 1828, however, Brunel obtained cement from Aspdin's works at Wakefield for use in the construction of the Thames Tunnel. In 1845 Sir Robert Peel proposed to tax Roman Cement under the mistaken assumption that the supplies would become exhausted, and when Aspdin convinced the illustrious commoner of his mistake the proposal was abandoned.

Brunel, when constructing the Thames Tunnel in 1839, gave a testimonial as to Roman Cement being extremely uniform in quality, and on every occasion up to his expectation. Robert Stephenson, in 1843, writing with regard to the use of cement in the construction of tunnels, pointed out that its excellence was sufficiently demonstrated by the state of the works several years afterwards.

It was just after this period that improvements in the manufacture of Portland Cement brought it more into favour and led to the gradual displacement of Roman Cement, although the latter, being particularly suited to some purposes, continues to be manufactured.

In the great Exhibition of 1851, in Hyde Park, some tests were made with briquettes, and the strain of neat Portland Cement was found to equal 414lb. per square inch. This Exhibition undoubtedly gave greater impetus to the industry, and in 1859 Mr. John Grant, Engineer to the Metropolitan Board of Works, decided to use Portland Cement in the construction of the London Drainage Canal, and published his reasons for so doing in the transactions of the Institute of Civil Engineers.

Other factories were rapidly established in the districts of the Thames and Medway, where the presence of ample supplies of chalk and alluvial clay offered strong inducements.

The British manufacturer was for many years severely handicapped in his efforts to improve the product by the custom which existed of every engineer drawing up his own specification for cement, a requirement specified in one clause often rendering the stipulations of another impossible of fulfilment, owing to the lack of knowledge of details of its manufacture.

To-day that difficulty has largely disappeared as a result of the publication in December, 1904, of the "British Standard Specification" for Portland Cement. This specification is generally adopted and gives satisfaction, although as a result of experience it has been found advisable to revise it in certain details, and revised editions have appeared in June, 1907, August, 1910, and March, 1915.

CHAPTER III

DEVELOPMENT OF THE INDUSTRY

THE rapidity of the growth of the Portland Cement industry is one of the most important features of the world's engineering progress. Yet although its developments appear wonderful and manufacturing equipments complete, the possibilities in the direction of cement production cannot be estimated by the scientist. He has only the assurance that his work is surely helping to build up and to consolidate what is destined to be a supremely powerful factor in the world's progress.

Every year more of this indispensable building material is being used, and the growth in its use during the past decade is an indication of the high position which it has attained in the business world of to-day. Those who have most closely followed the history and development of the industry look forward confidently to a greatly increased consumption and to a large addition to the variety of its uses.

It already enters into the composition of at least five hundred different articles and types of construction. While its principal and most common use is in street and highway paving, in the construction of canals, docks, piers, wharves, tunnels, buildings, bridges, retaining walls, and the like, a stage of development in its use has been reached when it is as efficient for drain-tiling as for bridges, for the erection of statues and other ornamental work as for canals, for water troughs as for street pavement, and for fence posts as for silos.

Far-seeing captains of industry have predicted that "the steel age" through which the world's civilized life is passing will give place to a concrete period. Most of the greatest engineering triumphs of modern times, such as, for example, the Nile Dam at Assouan, the Barrage at Assiout, and the Panama Canal, have been rendered possible only by the extensive use of Portland Cement concrete.

In this, as in so many other fields of commercial activity, America is pre-eminent. Only twelve years ago Mr. R. W. Leslie, Assoc. Am. Soc. C.E., in a paper read to the International Engineering Congress at St. Louis, predicted that the Portland Cement industry in U.S.A. would take rank with the great manufacturing interests, and exceed the output of any other country in the world. In 1913 the three largest producing countries were Great Britain, with 3,000,000 tons; Germany, with 5,000,000 tons; and U.S.A., with 15,348,000 tons.

This output was due to the new processes of manufacture adopted, and now practised everywhere, to the scientific reputation of its quality, and to the commercial brilliance with which the trade in American Portland Cement has been developed.

Perfection of treatment and reliability of quality can only be reached from the result of keen scientific research and practical experience, two essential features in the manufacture of the commodity for to-day's market. Without doubt architects and engineers fully realize and appreciate the efforts of manufacturers in producing a Portland Cement which may be used with absolute safety not only for the benefit of their own but future generations.

Many lesser industries have been established in order to supply the needs of the manufacturers of cement, and competition in the type and construction of machinery for all processes of cement-making, from quarry to stock-house, has enabled manufacturers to overcome difficulties in both the raw and clinker stages. Much, however, remains to be accomplished before Great Britain is able to regain her position in the Portland Cement world and hold it against all comers, but to ensure success there must be complete understanding and co-operation between manufacturers of cement-making machinery and the manufacturers of cement.

CHAPTER IV

MANUFACTURE

RAW MATERIALS

Portland Cement can be produced from any raw materials containing constituents capable of yielding by calcination the silicates and aluminates of lime which form its chief components, and the necessary constituents of these raw materials are lime, silica, and alumina.

The raw materials employed may be classed under two heads : (1) Calcareous, (2) Argillaceous, according as the lime or silica and alumina predominate.

Calcareous : Limestone, marl, chalk, alkali waste.

Argillaceous : Clayey limestone, clay, shale, blast-furnace slag.

Limestone

Limestone is largely composed of carbonate of lime. It sometimes contains carbonate of magnesia, and when this reaches 45 per cent of the total carbonates it is known as dolomite.

Limestone to be suitable for cement manufacture should not contain more than 4 per cent of carbonate of magnesia.

Chalk

Chalk consists of almost pure carbonate of lime, an excellent cement-making material, being crushed and pulverized easily.

Marl

Marl is more or less a pure carbonate of lime. White marls are usually free from organic matter, but the grey marls contain 5 to 10 per cent of impurities.

It is also an excellent material to pulverize, being soft and friable.

Alkali Waste

Alkali waste is a by-product from the processes used at alkali works in the manufacture of caustic soda. It is a fine-grained soft and pure form of lime carbonate ; from certain processes it contains large percentages of sulphur, which render it unfit for the manufacture of Portland Cement.

Clayey Limestone

Clayey limestone, known in the United States of America as "Cement Rock" when containing 50 to 80 per cent of lime carbonate and not more than 4 per cent of magnesium carbonate,

is an ideal material for Portland Cement manufacture ; it is considerably softer than pure limestone, consequently more easily crushed and pulverized.

Clay

Clays are essentially chemical compounds, containing silica, alumina, oxide of iron, lime, magnesia, sulphuric anhydride, and alkalis.

Shale

Shale may be considered merely a solidified clay, since the chemical composition of the two are similar.

Blast-Furnace Slag

Blast-furnace slag is a by-product from iron furnaces. It consists essentially of lime, silica, and alumina, with small percentages of iron oxide and magnesia.

Proportioning the Raw Materials

Firstly.—All these deposits must be subjected to various processes of amalgamation to bring them within the limits of the chemical composition so vital for the production of a well-balanced volume constant Portland Cement.

The exact proportions required are determined by the actual chemical composition of the materials combined, since each of the ingredients as found in nature, or as a result of some process of manufacture, includes a certain proportion of the other principal ingredient, together with various foreign materials which are not essential to the manufacture of cement.

Secondly.—The importance of the fine grinding of the materials is the greatest factor in producing a sound cement—in fact, 90 to 95 per cent of the mixture should pass through a sieve having 32,400 holes per square inch.

Composition of Mixture.—A Portland Cement mixture, when ready for burning, should contain about 75 per cent of lime carbonate (Ca C O_3) and about 20 per cent silica (Si O_2), alumina ($\text{Al}_2 \text{O}_3$), and iron oxide ($\text{Fe}_2 \text{O}_3$) together, the remaining 5 per cent containing only magnesia, sulphur, and alkalis that may be present.

These substances are obtainable in the large range of choice of raw materials before mentioned.

Good commercial cements should have the following limits of these ingredients :—

Silica	20-5 per cent.
Alumina	4-8 "
Oxide of iron	2-5 "
Lime	60-7 "
Magnesia	0-2 "
Sulphuric anhydride	0-2 "

SYNOPSIS OF MANUFACTURE FROM THE RAW MATERIAL TO
PORTLAND CEMENT

Quarry (Mechanical Process)

The initial step in the manufacture of Portland Cement is the excavation of the raw materials.

Crushing, Grinding, and Mixing of Raw Materials
(Mechanical Process)

The second step is the thorough crushing, grinding, and mixing of the raw materials to such fineness that 90 to 95 per cent of the mixture will pass through a sieve having 32,400 holes per square inch.

The Burning of the Raw Materials to Incipient Fusion
(Chemical Process)

The third step is the calcination of the raw materials and chemical section of the manufacture, for the water present naturally in the raw materials and that added for mixing purposes are evaporated, after which it reaches a temperature where all organic matter from the clay and carbonic anhydride (CO_2) from the carbonate of lime is expelled in the form of gas, and lastly it reaches that zone of the kiln, the temperature being 2,600 degrees to 3,000 degrees F., where the chemical combination of the lime with the silica and alumina of the clay takes place, producing Portland Cement clinker.

Cooling and Grinding the Clinker
(Mechanical Process)

The fourth and final step is the cooling and grinding of the clinker. The heat from the clinker is extracted by passing through a rotary cooler situated immediately under the kiln, and is carried back to the kiln by the incoming air to the zone of combustion.

The clinker is now reduced to a coarse powder by a preliminary grinder and ground to the required fineness in a finishing mill, and is so fine that 90 to 95 per cent of the product will pass through a sieve having 32,400 holes per square inch, and is now Portland Cement.

COMPOSITION AND MANUFACTURE OF CEMENT

Definition : British Standard Specification

The cement shall be manufactured by intimately mixing together calcareous and argillaceous materials, burning them at a clinkering temperature and grinding the resulting clinker.

No addition of any material shall be made after burning, other than calcium sulphate, or water, or both, and then only if desired by the vendor, and not prohibited in writing by the purchaser.

Definition : American Standard Specification

This term is applied to the finely pulverized product resulting from the calcination to incipient fusion of an intimate mixture of properly proportioned argillaceous and calcareous materials, and to which no addition greater than 3 per cent has been made subsequent to calcination.

Definition : German Standard Specification

Portland Cement is a product made by an intimate mixing of finely ground calcareous and argillaceous materials or calcareous and argillaceous silicates burnt to incipient fusion and ground to flour. An addition of 3 per cent of calcium sulphate is allowed to regulate the setting time subsequent to calcination.

So the distinguishing feature in the manufacture of Portland Cement is the heating of the raw materials to incipient fusion or clinkering temperature. The importance of fine grinding of the raw materials is at once apparent, perfect chemical combination can only take place when the necessary materials are in the finest possible state of subdivision, and the clinker produced from the rotary kiln is so compact and stable that it may be kept for long periods exposed to a moist atmosphere without any signs of disintegration ; whereas clinker produced from the same raw materials by older methods is always subject more or less to breaking down of the pieces when exposed to the air for any length of time.

This phenomenon is probably due to the presence of some less stable compounds produced at various temperatures owing to the difficulty of obtaining an equable distribution of heat in the intermittent kiln.

When the clinker is ground to a fine powder and mixed with water chemical action takes place, and a hard mass is formed. This change from the plastic to the solid state of the cement mortar is termed "setting", after which a gradual increase in cohesive strength is acquired and known as "hardening".

Cements usually require from six months to a year to give their *full* strength.

WET AND DRY PROCESSES OF MANUFACTURE

Unquestionably, the greatest controversy amongst modern cement manufacturers ranges round the question of the mixing of the raw materials. One school advocates the wet method as being the most efficient and likely to ensure the most uniform product, whilst others will, for precisely the same reasons, advocate the dry method.

Everyone is agreed, however, that the main factors in

determining which is preferable are the quality of the product and the cost of production.

Hitherto it has been the general practice to adopt without question the dry process, where crystalline limestone was used. Now, the amount of moisture contained in the limestone ranges from $\frac{1}{2}$ to 3 per cent, and in clay from 1 to 30 per cent. This necessitates the drying of the materials to ensure economical grinding and mixing.

On the other hand, no one would dream of adopting the dry process where the materials are soft and of such a nature that they can, by the addition of water, be ground to the necessary fineness, say, about 8 per cent residue in 180² mesh, the resultant slurry containing from 40 per cent to 42 per cent of moisture, and being easily capable of being pumped to storage mixing tanks ready for the kilns.

It is a significant fact, however, that on the Continent of Europe and in the United States, where the dry process was previously general, several modern plants have adopted the wet method of preparation.

The quality of wet and dry made cements may be considered equal, provided they are both properly prepared, that is, ground sufficiently finely and evenly mixed.

Suppose, therefore, we have in the dry process a perfect mixture. The important question is: Can that perfect mixture of carbonate of lime (CaCO_3), silica (SiO_2), and alumina (Al_2O_3) be maintained in its passage through the rotary kiln to the zone of calcination, and especially so when the carbonic gas (CO_2) has been driven off from the carbonate of lime, thereby rendering the free lime very susceptible to the scattering influence of the strong draught of the rotary kiln.

Now, despite the investigations of some of our most noted scientists, the chemistry of Portland Cement is far from being thoroughly understood. Nevertheless, the safe limits of the essential ingredients are well known. Assuming that three molecules of lime are united to one of silica to form the tricalcium silicate, and that two or three molecules of lime are united to one of alumina to form the dicalcium or tricalcium aluminate, it necessarily follows that this perfect mixture of lime, silica, and alumina must be assured, not only at the commencement, but maintained to the zone of calcination if a sound mixture is to be the result.

What is the result? Extra expense is incurred through the necessity of watering the clinker and providing large store-houses for "ageing" it in order to produce the requisite soundness.

On the other hand, in the wet process we have an equally perfect mixture of raw materials, but being in the form of slurry

it is obvious the particles cannot in any way be affected by the strong draught of the rotary kiln, since the whole is first in a fluid mass, then in the plastic condition as the moisture is driven off, and finally in small friable balls, which easily crumble to powder a few feet from the zone of fusion ; consequently a more regular product is obtained, free lime is practically absent, and "ageing" is therefore not necessary.

Tests of cement from clinker ground direct from the cooler after the usual twenty-four hours aeration have proved absolutely volume-constant using the wet process.

It has been argued that the fuel consumption is much larger in the wet process than in the dry, but the advent of long kilns, measuring from 200 to 250 feet and from 8 to 10 feet in diameter, has quite disposed of this argument. Indeed, if we take into consideration the amount of coal used in the latter process to dry the materials the balance would almost certainly be in favour of the wet process. At well-known works in Great Britain a ton of cement can be burnt with 27 to 30 per cent of coal of average calorific value, as received at the works ; after drying it would average about 25 per cent.

Further, the cost of the wet plant is, without question, much lower than that of the dry, whilst the amount of labour required is also considerably less. No rotary driers are required. There are no bins for the reception of the ground raw materials over the finishing mills, and all the attendant complicated system of conveyors, elevators, and automatic scales can be dispensed with.

The process, too, is much simpler in the wet method. The raw materials can be proportioned volumetrically before the grinding mills, whence the thick slurry is gravitated or pumped into large reservoirs, each capable of holding sufficient to make 600 tons of cement, and in these it is kept in a constant state of agitation to avoid settling.

These tanks are under the supervision of the chemist, who does not make use of the slurry for calcination purposes till he is satisfied that it is of correct proportion. When this standardizing is complete the mixture has simply to be pumped into the rotary kiln.

CHAPTER V

DESIGN AND CONSTRUCTION OF A MODERN PORTLAND CEMENT PLANT

THE design and construction of a modern Portland Cement plant are of the utmost importance to the investors and manufacturers, and should be the subject of much deliberation and investigation before being undertaken.

The question of factory, its process, equipment, capacity, and quality of cement it will produce, is of vital importance.

To ensure a good earning power, a Portland Cement factory must first of all have capacity corresponding with the capital invested ; it must be equipped with machinery that is certain to do its work from year to year without trouble and annoyance, and the process of manufacture must be one that will ensure a uniform high-grade cement.

Business men building a cement plant should see that the engineers engaged to design, construct, and equip a plant are *those who have gained their knowledge after years of practical experience in cement-making*, and not those who have visited a few cement works in Great Britain and Europe, gleaning information from owners and managers that often proves very expensive to those who have speculated in cement, causing them disappointment and regret at having interested themselves in the industry.

Many estimates of engineers have come very wide of the mark, and plants have been turned over to the owners by engineers erecting them, only for the former to find £10,000 to £50,000 must be spent in order to make the changes necessary to a successful, economical operation of the plant ; *with the knowledge now available a well-equipped works can be guaranteed to give the output required and maintain it.*

SITE

First of all the locality of the site must be thoroughly explored in order to ascertain if suitable raw materials are present in sufficient quantities to ensure continuous working for a considerable number of years.

Such an investigation requires the services of engineers and chemists thoroughly skilled, not only in the design and erection of Portland Cement plants, but also in their operation, and especially those with personal experience of various raw materials used in cement manufacture. Many plants in operation to-day have suffered considerable losses through commencing construction

without an adequate knowledge of the deposits of the raw material, and even with no reliable survey of the proposed quarry to guide the location and erection. This point proving satisfactory, the manufacturer should next consider the suitability of the site with regard to its available rail and water communication with the necessary markets, since inaccessibility must, of course, always mean increased expenditure and often failure.

SIZE

The size of the plant is frequently a matter of very grave speculation and must be largely governed by the available markets, but a modern cement plant to-day must have large capacity and low cost of manufacture, requisites attained only by careful design and construction. Provision should always be made in the design to increase the capacity of the plant if necessary. If actual figures were required, a plant capable of producing 450 to 500 tons daily, say 3,000 tons weekly, would appear to be the ideal one for combining the maxima of efficiency and economy.

DESIGN AND CONSTRUCTION

Of course, no hard and fast rule can be laid down as to the design and construction of a plant, nor as to the particular machinery to be used, but in all construction two leading features should never be lost sight of, viz. :

1. Simplicity of design.
2. Strength of construction.

Experience has clearly proven that the heaviest and best machinery must be used in the Portland Cement plant. Simple, powerful, and economical construction is necessary to ensure durability and efficiency under heavy service. Complications are always elements of weakness. Lubrication must be automatic and reliable.

Rapidity of repairs and interchangeability must be ensured, whilst lifting appliances should be provided over all machines for rapid dismantling, since continuous operation is imperative, and delays due to breakdowns are expensive and must be attended to promptly.

Mechanical devices should be used whenever possible to eliminate manual labour.

Ample storage should be arranged for materials in the different stages to ensure at least twelve hours running in case of a breakdown in any department, and so avoiding the entire plant being stopped.

Owing to the comparative absence of competition in the early days of the industry in Great Britain, very little attention was paid to the engineering features of the factories. As the demand

for the commodity increased the producers extended their plants again and again, until they became most complicated, and to the outside observer appeared to be a chaotic mass of dusty brick buildings and chimneys.

With increased competition, however, these manufacturers found they were being outstripped by their foreign rivals, and are now modernizing their old factories and erecting up-to-date plants.

In no other industry is the wear and tear on the machinery so great. Having to run day and night, it follows that every portion of the plant must be of the best possible material and workmanship, and so arranged as to afford ready access in case of breakdowns.

There are in existence many types of machinery for all the processes of cement-making, and much attention is still being given to its design, more especially abroad, but the manufacturer in erecting a new plant should reject anything of a complex nature as being unsuitable for the profitable production of cement, whilst his margin of profit will be very small indeed if his plant is not so constructed as to withstand the heavy service to which it is subjected.

Finally, since repairs and renewals are very expensive items, no factory can be considered complete without an efficiently equipped repair shop.

QUARRY PRACTICE

So much study has been given to the development of mechanical economics for excavating of the raw materials, the first step towards the actual manufacture of cement, that the little army of men who went into the quarry with sledge and pick to win the materials by hand and load it into little cars must give place, if it has not already done so, to the indispensable steam shovel and the big blast hole method of drilling.

The industrial locomotive with its train of cars, being loaded at the rate of 80 to 100 tons per hour by the steam shovel and run direct to the crusher or the storage ground, is now the prevailing practice.

Mechanical means are also provided for the stripping of heavy overburden from the limestone, chalk, or clay deposits, a very expensive operation by hand labour; it is very necessary to remove this foreign matter from the pure material to be used for the manufacture.

No difficulty will be experienced when once the quarry is opened up for the steam shovel to excavate the guaranteed capacity.

All material should be won from the quarry for the week's output of cement in fifty to sixty hours (if the weather is



STEAM SHOVEL EXCAVATING MATERIAL FOR A PORTLAND CEMENT PLANT.

[To face page 16.



Showing the usefulness of the CRANE NAVVY in quarry work. The machine at the top is removing the top soil or overburden, and the machine in the bottom is excavating the mineral, which in this case is chalk for making cement.

[To face page 16.]

favourable), leaving part of Saturday morning to overhaul and carry out repairs to the steam shovel, etc.

Blasting operations should take place once a week, on Saturday just after noon, when men are away; the charging of holes and other preparations can be carried out during the morning.

BIG HOLE BLASTING DRILLS

“ Within the last two or three years the great advancement in the production of cement, the reduction in cost of production, and the increase in output have been considerably aided by the big blast hole method of drilling. The drilling proposition to-day ranks among the prime factors of cement or lime production, for if the drill fails the whole plant shuts down.

“ Until very recently the tripod method of drilling, as well as many other ‘rule-of-thumb’ methods, was accepted without question, and what little reduction in the cost and increase in production were effected were due rather to the extra efforts put forth by the men than to the methods they employed. Although there are quarry owners who still use the small hole method, they are few and their number is rapidly diminishing. The big hole drills are replacing the small hole drills, and in the great majority of cases more than pay for themselves in the course of a few months. The reason for this is evident as soon as the advantages of the big hole method are known. A few of these advantages are as follows:—

“ *First.* The per ton drilling cost is less, due to the wider spacing. Figuring the tripod hole at an average of $2\frac{1}{4}$ inches and the big blast hole at $5\frac{1}{2}$ inches in diameter, we then have a capacity ratio between the two holes of 3.97 to 23.76. The general rule followed in preliminary testing in blasting is that 1 square inch of drill hole will displace $8\frac{1}{2}$ square feet of stone. Figuring on this basis, the tripod hole will handle 33.74 square feet and the big blast hole will handle 201.96 square feet, which means that it will require 5.99 times as much small hole drilling as large hole drilling.

“ *Second.* On account of the deeper hole in big hole drilling, the loss occasioned by ‘blowing out’ will be eliminated, thus effecting a saving in the cost of explosives of from 200 to 500 per cent.

“ *Third.* The big holes are drilled the full depth of the breast, and thus they do away with benchmen, who are not only expensive as labour but are also expensive risks, as they are not only in danger themselves but are a menace to the workmen below. Another expense connected with bench-cleaning is the loss in productive capacity of the men on the floor of the quarry on account of being on the look out for the men above. This item ranges from 10 to 20 per cent loss in efficiency to a complete

non-production of a certain section of the quarry, where, on account of the risk involved, it is necessary to abandon loading until the bench-cleaning operations are over.

"*Fourth.* Such a large amount of stone can be shot down at one time that it makes it possible to keep a steady and uniform supply of rock ahead of the men, thus bringing the production of the plant up to the maximum.

"*Fifth.* The shooting is done less often, thus eliminating lost time.

"*Sixth.* Big holes are easier to load, and, compared with the tonnage, are cheaper to load, as a big hole can be loaded in about the same time as a small one.

"*Seventh.* Big holes are of the same diameter at the bottom as at the top, and thus it is possible to load the most explosive where it will do the most good—in the bottom.

"*Eighth.* On account of the heavier charge, and being able to place it properly, the stone will be broken much finer than by the small hole method, thus facilitating the handling and also greatly reducing the work of the crusher.

"The eight advantages above enumerated are the primary advantages, and should be noted when the installation of a big blast hole is being considered. The modern big hole operator takes a broad survey of his proposition, and while it is naturally expected that the big drill will save on that part of the work to which it is directly charged, namely, drilling, still in making calculations the careful operator will judge this item of drill saving by final results and final costs.

"The following comparative cost data are taken from reports from quarries where Cyclone big blast hole drills are in operation, and gives the savings being effected by the big hole method over the tripod method of drilling:—

<i>First Plant</i>	
Material gotten out for	Cement
Quarry breast	30'
Stratification	Thin, shelly
Method of loading	Shovel
Average size of tripod holes	2½"
Size of big blast holes	5½"
Spacing of tripod holes	6' × 6'
Spacing of big blast holes	14' × 14'
Cost of drilling per ton—tripod	7.0 cts.
Cost of drilling per ton—big-hole	0.6 "
Cost of shooting per ton—tripod	3.5 "
Cost of shooting per ton—big-hole	2.8 "
Drilling per day—tripod	35'
Drilling per day—big-hole	90'
Saving in drilling per ton	6.4 cts.
Saving in shooting per ton	0.4 "
Saving in overhead per ton	No data
Total saving per ton	6.8 cts.

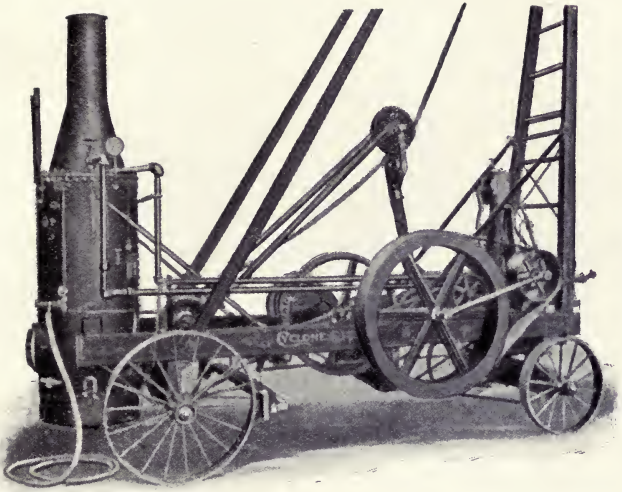

CYCLONE DRILL.



BIG BLAST HOLE DRILLS IN OPERATION.

[To face page 18.]

Second Plant

Material gotten out for	Crushed rock
Quarry breast	40'
Stratification	2'-8'
Method of loading	Biggest shovels
Average size of tripod holes	5" top, 3½" bottom
Size of big blast holes	5½"
Spacing of tripod holes	8' × 8'
Spacing of big holes	18' × 12'
Cost of drilling per ton—tripod	5.76 cts.
Cost of drilling per ton—big holes	0.82 ,,
Cost of shooting per ton—tripod	3.98 ,,
Cost of shooting per ton—big holes	2.94 cts.
Drilling per day—tripod	34.6'
Drilling per day—big holes	64.2'
Saving in drilling per ton	4.94 cts.
Saving in shooting per ton	1.04 ,,
Saving in overhead per ton	Unable to figure
<hr/>	
Total saving per ton	5.98 cts.

Third Plant

Material gotten out for	Crushed rock
Quarry breast	50'
Stratification	2'-10'
Method of loading	Hand
Average size of tripod holes	2½"
Size of big blast holes	5½"
Spacing of tripod holes	5' × 5'
Spacing of big holes	13' × 13'
Cost of drilling per ton—tripod	4.3 cts.
Cost of drilling per ton—big holes	0.88 ,,
Cost of shooting per ton—tripod	3.2 ,,
Cost of shooting per ton—big holes	2.8 ,,
Drilling per day—tripod	50'
Drilling per day—big holes	50'
Saving in drilling per ton	3.42 cts.
Saving in shooting per ton	0.40 ,,
Saving in overhead per ton	1.70 ,,
<hr/>	
Total saving per ton	5.52 cts.

“The three comparisons made will give some idea of how the saving in drilling, shooting, and overhead runs. There are some plants doing better than the figures given herewith, while there are, of course, others which do not show up so well. In any event, the big hole method of blasting in connexion with the manufacture of lime or cement, or in connexion with quarry work in general, has been or is being adopted by all of the leading and up-to-date cement, lime, and stone companies throughout the U.S.”¹

STORAGE OF RAW MATERIALS

For many years the locomotive crane and grab has been used with great success in unloading coal, coke, gypsum, etc., from barges and lighters on Portland Cement factories.

¹ Extract from *Concrete-Cement Age*, July, 1914.

In the case of coal for rotary kilns, it is grabbed from the barge or lighter and put into a hopper over the crushing rolls at a cost in wages of 1*d.* to 1½*d.* per ton.

The storing of raw materials direct from the quarries should claim the serious attention of all cement manufacturers.

It is essential that the plant should run without interruption (in wet weather the quarry operations are often stopped), although provision has been made in each slurry storage tank for an approximately three days' supply for one kiln.

The fact of closing down the crushers and wet grinding mills means a serious loss.

The locomotive crane with a suitable grab-bucket can be well utilized in a raw material storage ground. Local conditions and surroundings of the crushing and clay washmill plants will guide the plans and lay out of the storage ground.

The storage capacity should represent one week's run of the plant. Advantage should be taken of favourable weather to maintain the supply.

In the United States, where the conditions of the weather during the winter months are particularly bad, a large Portland Cement Company employs an electric locomotive crane, having a 65 ft. radius and operating a 2 yd. bucket, for the purpose of storing crushed limestone during the summer months, and accumulate such a supply of material that the mill could be operated during the winter without operating the quarry, which runs into excessive cost in the winter time.

The storage capacity of the installation amounts to approximately 100,000 tons.

The material is delivered from the crusher to an underground conveyor, which feeds into an elevator that is located in the middle of a circular track. This elevator discharges at a convenient location, so that it can be handled by the grab-bucket of the locomotive crane to a storage area outside of the circular track.

The circular storage system is patented by the Link-Belt Company, Chicago, Ill., U.S.A.

CRUSHING AND GRINDING THE RAW MATERIALS

The crushing and grinding practice of the raw materials in cement manufacture is of the greatest importance, and closely associated with the financial success or failure of the works.

In round figures, for every ton of cement produced 32 cwt. of raw materials have to be crushed and ground to an impalpable condition, so that 90 to 95 per cent passes through a sieve with 32,400 hole to the square inch. Approximately 75 per cent of this material is hard limestone, so it will at once be apparent to



STEAM CRANE FOR CIRCULAR COAL STORAGE SYSTEM (20 ft. gauge, 80 ft. radius, 2 ton bucket, 80,000 tons storage capacity).

business men how rapidly money may be lost by improper methods at this preliminary stage of the process.

CRUSHING

Crushing of the hard raw materials as a commercial proposition has been a gradual one, as the perfection of machinery and mechanical devices for handling the materials has developed, and requires special consideration when being designed to suit local conditions.

But the following general principles are essential :—

- (1) Handling the raw materials with the greatest efficiency.
- (2) Installing powerful crushing machinery with large reserve power.
- (3) Adopting the gradual reduction system.
- (4) Installing large elevators and conveying belting to deal with the material efficiently.

The cars as they arrive from the quarry with the limestone will be dumped by the tippler into a hopper over a feeding apparatus to the primary crusher ; it is not good practice to tip the material direct into the mouth of the crusher, the lumps of limestone get wedged together, causing much delay. With a feeding device this trouble is overcome ; the attendant has complete control over the feed, the sure method to obtain the maximum output.

The mouth of the crusher must be somewhat larger than the navy shovel to ensure that all lumps of limestone passing from the bottom of the shovel will pass the mouth of the crusher, or much time will be wasted by breaking the stone at the crusher mouth, which is not only dangerous, but bad practice.

From the primary crusher the material passes through a rotary screen with 2 in. mesh. The limestone passing through the screen is conveyed to a hopper over the crushing rolls ; the tailings passing are automatically fed into an elevator, which conveys them to a steel pocket with chutes converging directly over gyratory crushers, and passing through them are also conveyed to the hopper over the crushing rolls.

The crushing rolls reduce the material to $\frac{1}{2}$ in. to $\frac{3}{4}$ in. mesh, the limestone being fed from the hopper by an automatic device, so essential to get the best results. It is now conveyed to bins, over the wet ball mills, which must be large enough for a twelve hours full supply to each mill.

A reserve hopper should be provided to supply the mills in case they run out during the night or other emergency.

The crushing machinery installed for an output of 3,000 tons of Portland Cement must be capable of crushing 3,600 to 4,000

tons of limestone in fifty-six hours, or even fifty hours per week, allowing Saturday morning for the gang to have a general overhaul and clean before leaving at 1 p.m. all in readiness for starting on Monday at 6 a.m. The number of men required for the crushing department will be five or six. (Piecework rates or a bonus given on the week's output.)

In the earlier days, many plants after preliminary treatment in a coarse crusher, completed the final reduction in one or two mills, *but this crude system has been modified out of existence, and all modern plants properly constructed have adopted the gradual reduction system.*

- | | |
|---|----------|
| (1) Primary crusher as received from quarry to 3 in.
to 6 in. | } Cubes. |
| (2) Secondary crusher to 2 in. | |
| (3) Crushing rolls to $\frac{1}{2}$ in. to $\frac{3}{4}$ in. | |
| (4) Ball or centrifugal mills, 40 to 50 mesh. | |
| (5) Tube or centrifugal mills, 90 to 95% through 180 ² mesh. | |

To ensure efficiency, capacity and economy, and make the commercial operation of the crushers what it should be, *the plant must first be properly designed by competent and experienced engineers*, the purchasing of high-class machinery does not alone ensure the perfect operation of a plant; the elevating and conveying machinery must have ample carrying capacity; and be well designed and fitted.

TYPES OF CRUSHERS

The types of crushers now generally adopted are the jaw crusher, the gyratory crusher, and roll crusher for final reduction. The primary crusher must be of large capacity to easily deal with the run-of-quarry product as excavated by the steam shovel. The jaw crusher as a primary crusher has the advantage of having a larger receiving opening, hereby greatly reducing the cost of quarrying and at the same time cost of crushing.

Experience has proven this so conclusively that manufacturers of crushing plants are now prepared to supply crushers to suit all conditions.

- (1) Jaw crusher: the material is crushed between two jaws; the one reciprocates, the other remains stationary.
- (2) Gyratory crusher: the material is crushed by a gyrating movement of a corrugated cone within a ring of corrugated steel plates.
- (3) Roll crusher: the material is crushed between two or more plain, corrugated, or toothed rollers.
- (4) Disc crusher: the material is crushed between two steel discs "A" and "B".

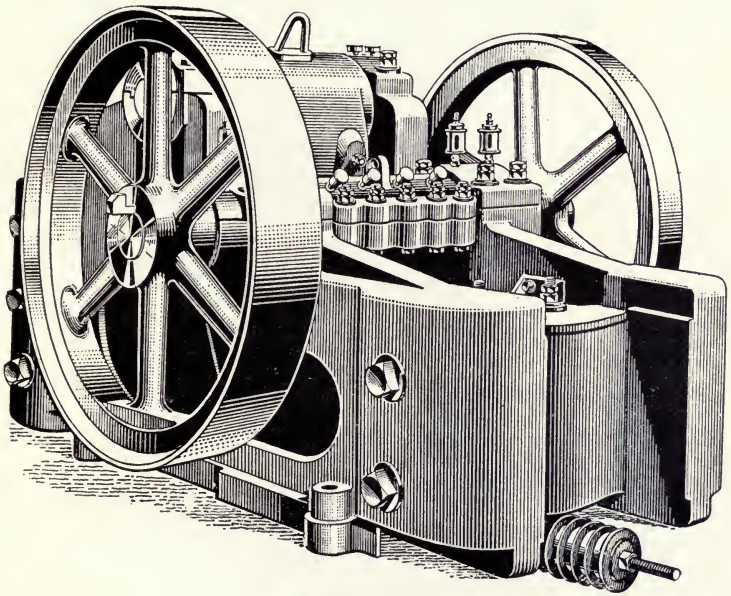

NEWELL'S SWINGING JAW CRUSHER.

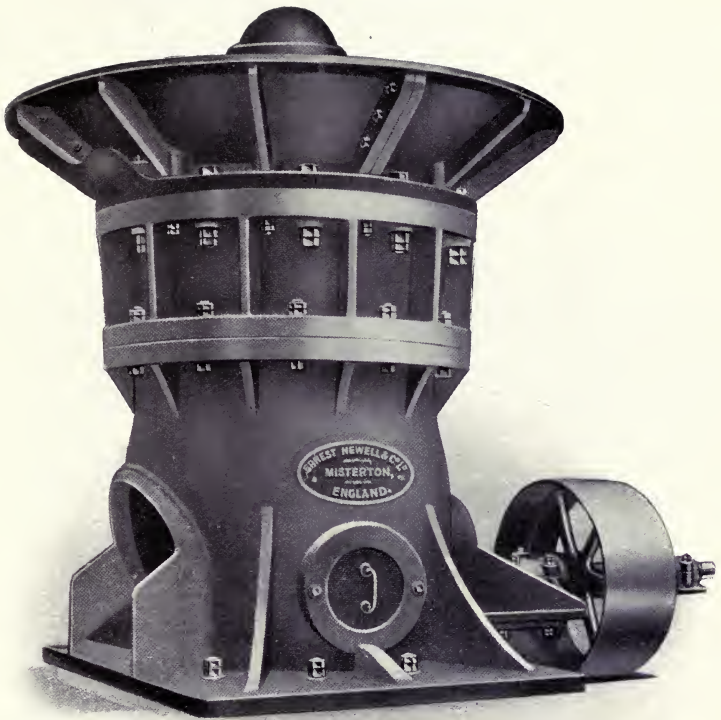

GYRATORY CRUSHER.



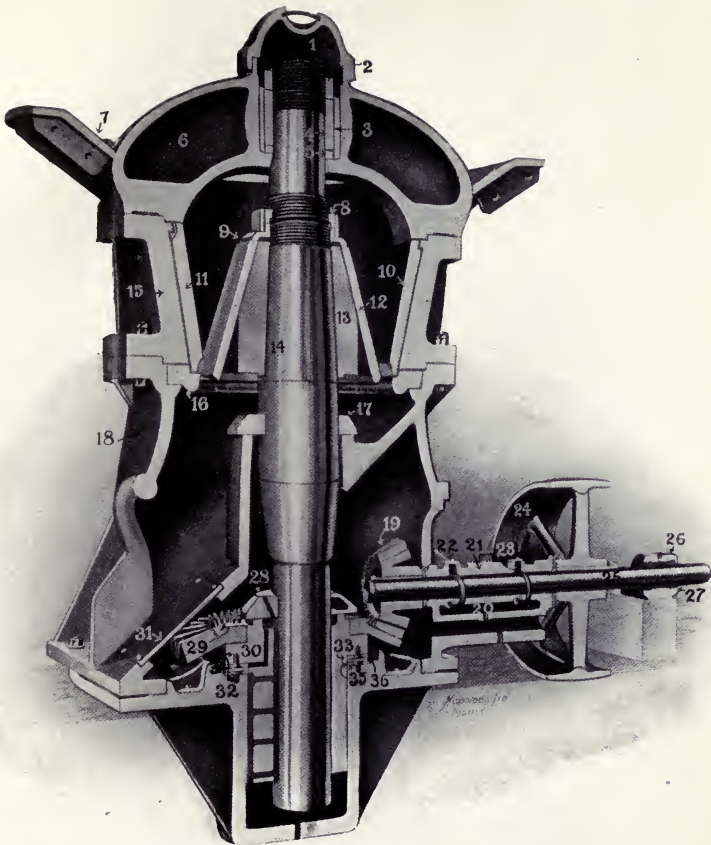

GYRATORY CRUSHER (SECTIONAL VIEW).

Symbol. Description.

1. Cap for spider.
2. Nut for suspension sleeve.
3. Bush for spider.
4. Suspension sleeve for vertical shaft.
5. Wearing ring for suspension sleeve.
6. Spider.
7. Feed hopper.
8. Loose collar for protecting threads on vertical shaft.
9. Bottom collar for crushing head.
10. Concave liners.
11. Concave key liner.
12. Mantel.
13. Crushing head centre.
14. Vertical shaft.
15. Shell.
16. Ring for supporting concaves.
17. Dust collar for skirt.
18. Skirt.

Symbol. Description.

19. Bevel pinion.
20. Main bearing body.
21. Main bearing cap.
22. Oil lid for cap.
23. Rings for main bearing.
24. Driving pulley.
25. Driving shaft.
26. Outboard bearing cap.
27. Outboard bearing body.
28. Dust-cap for eccentric hood.
29. Bevel wheel.
30. Eccentric hub.
31. Wearing plate for skirt discharge.
32. Bearing for hub.
33. Friction ring for eccentric hub.
34. Countersunk dowel pins for friction rings.
35. Friction ring for hub bearing.
36. Loose friction ring.

[To face page 22.]

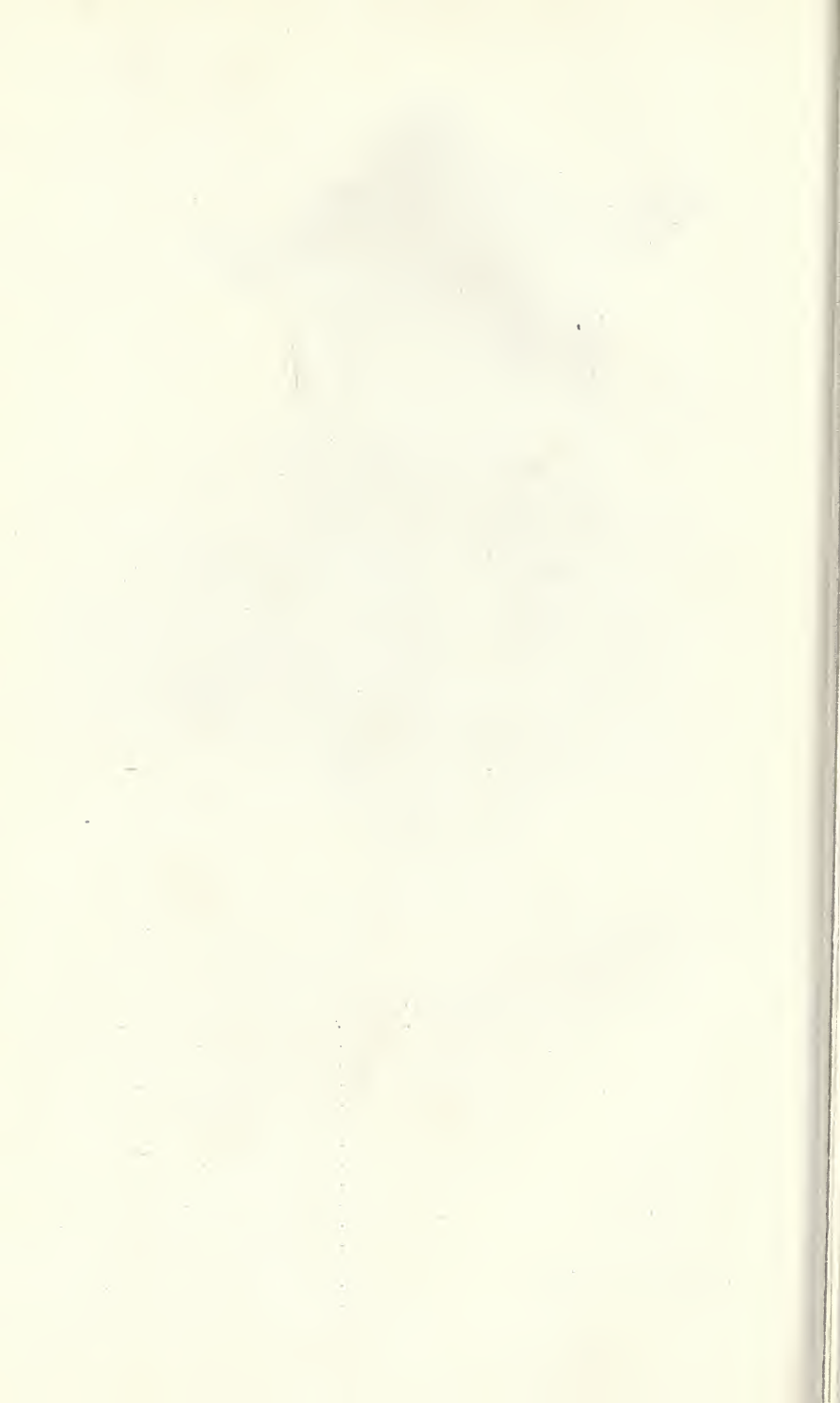

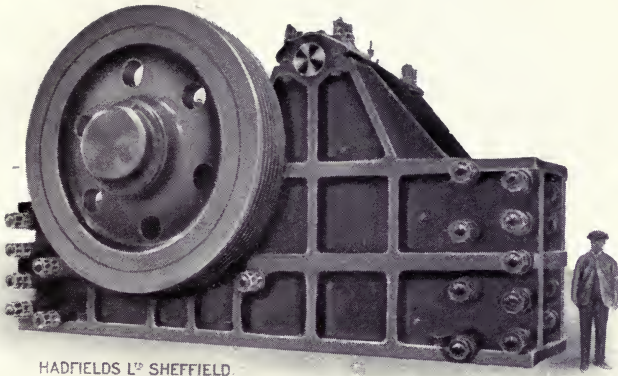

HADFIELD'S L^{TD} SHEFFIELD

RECIPROCATING JAW CRUSHER.

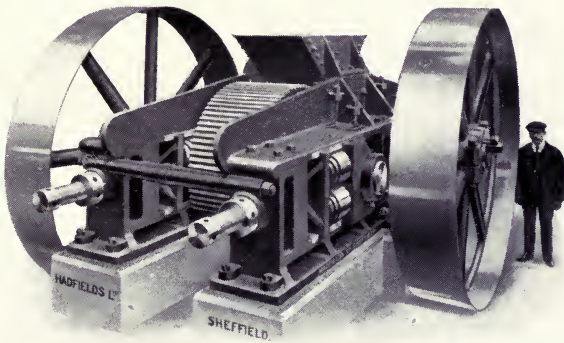

HORIZONTAL ROLL CRUSHER.

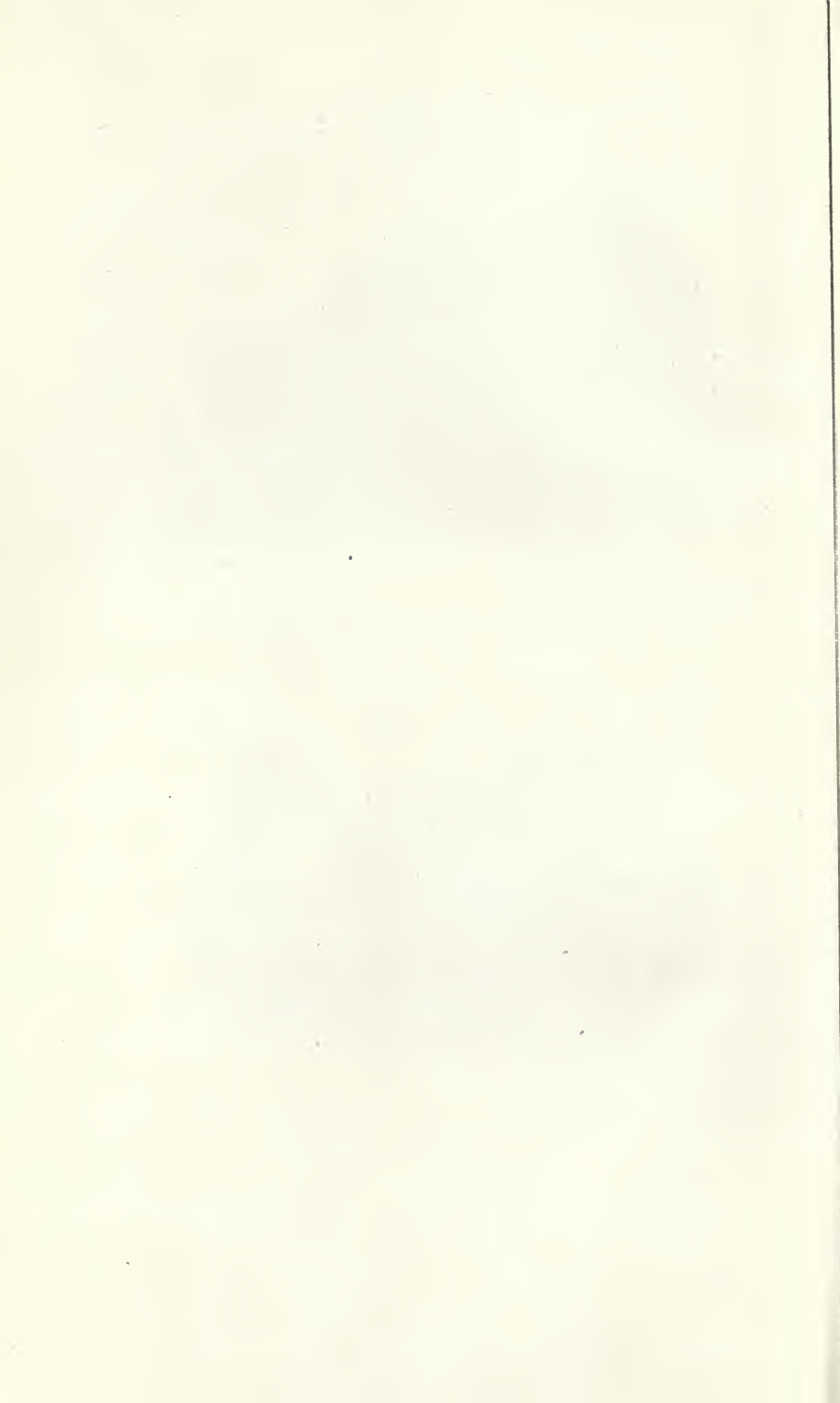

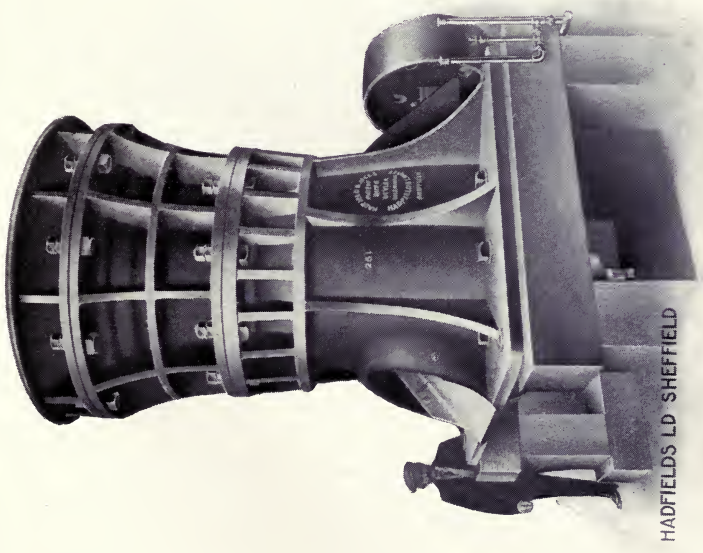

HADFIELDS LTD. SHEFFIELD

GYRATORY CRUSHER.

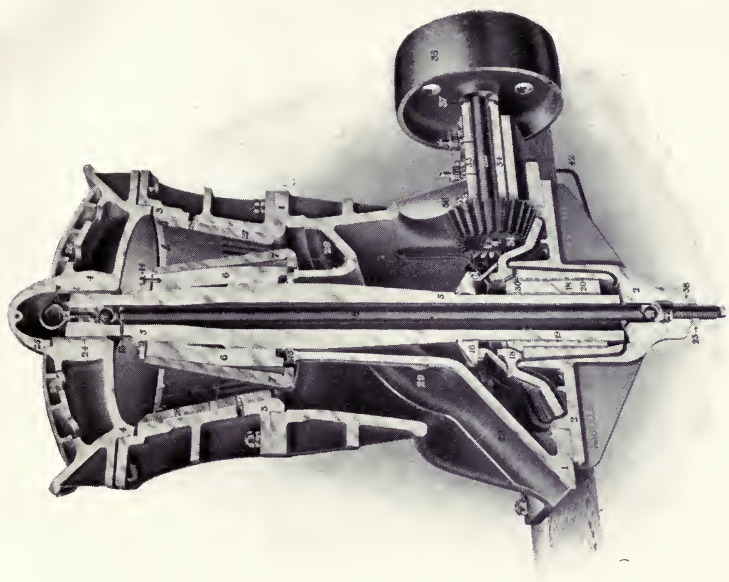

GYRATORY CRUSHER (SECTIONAL VIEW).

[To face page 22.

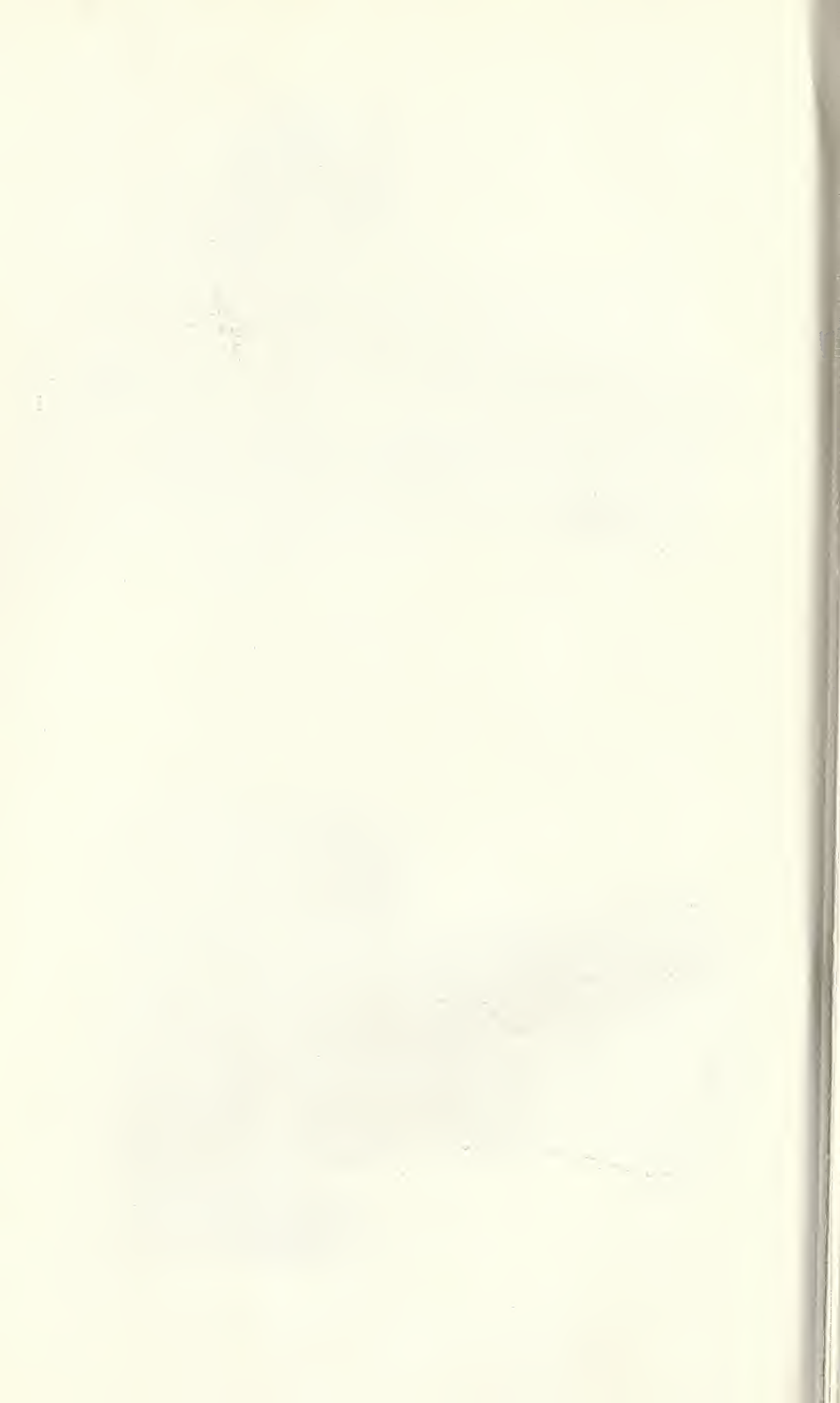

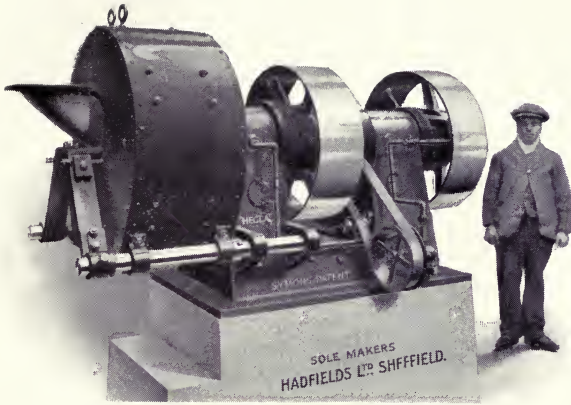

DISC CRUSHER.

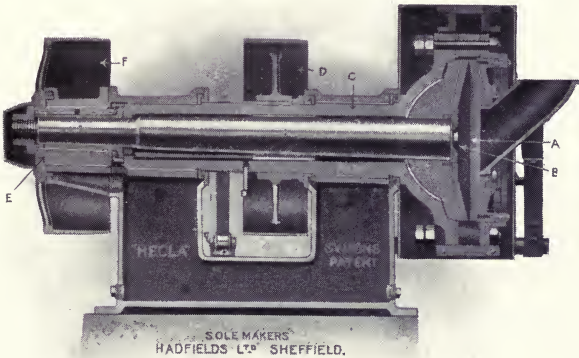

DISC CRUSHER (SECTIONAL VIEW).

GRINDING

The process of grinding is incident to almost every stage of the manufacture of cement, from its initial operation of reducing the raw materials to the final conversion of the clinker into the finished product. Hence, it is a very large and ever noticeable item on the debit side of the cement manufacturer's balance-sheet. And very properly so; for the commercial success of his plant depends very largely on the efficiency of his grinding machinery. Nothing, therefore, should be left to chance to secure perfect running in these most important departments of the factory.

In discussing this subject, it is convenient to embrace the grinding of both raw materials and clinker, as it is now the general practice to adopt a duplication of the grinding machinery for both purposes.

The importance of the fine grinding of the raw material to ensure a sound and volume-constant cement is now generally acknowledged, though in the early days of the industry this subject received but very scant attention. Everyone is now agreed that to ensure the materials entering into proper chemical combination when submitted to the clinkering temperature—about 2,800° F.—it is absolutely necessary that they should be in the finest possible state of subdivision.

Consider for a moment the amount of material that must be ground to an impalpable powder for a 3,000 ton weekly capacity plant, and, at the same time, bear in mind that the materials so ground may be crystalline limestone and shale.

This means that a bulk weighing 7,800 tons has to be ground so finely that from 90 to 95 per cent passes through a sieve with 32,400 holes to the square inch. Of this, 4,800 tons are in the original condition from the quarry. The remaining 3,000 tons are in the clinker condition, for it is necessary to grind this equally finely, if soundness—that most important quality of cement—is to be obtained. No matter how high a degree of tensile strength is obtained in comparatively short periods, if the product fails to resist the disintegrating influence of the atmosphere, or of the water in which it is placed, it is useless as a material of construction. This quality can only be attained by extremely fine grinding. Thus the absolute necessity of the most efficient grinding machinery is apparent.

Many disappointments have been experienced by owners of cement plants when the grinding machinery has failed to produce the quantity of raw material at the fineness required by the contractor or consulting engineer.

Manufacturers of grinding machinery naturally base the output of their mills upon the best results obtained from the materials

submitted for testing. It often happens, however, that these materials have been taken from the top layers, or from the face of a quarry where the rock has been "weathered" or softened, and to base grinding capacity on such results is entirely fallacious, since, as the quarry is developed, the excavated substances greatly increase in compactness and hardness, and the mills must, therefore, fail to give the results expected.

This also applies to clinker in the dry process where it is almost a necessity to burn to vitrification in order to secure a sound cement. It is obvious, of course, that clinker so burnt is much more solid than when merely brought to incipient infusion as in the wet process, and as a consequence the output is decreased whilst the wear and tear on the grinding machinery is very considerably increased.

There are many excellent types of crushing and grinding machinery on the market, and every manager or engineer would probably prove that his own particular appliances were fulfilling his purpose and performing the required work to his satisfaction.

Particulars are given of a few types largely in use.

THE BALL AND TUBE MILLS

These were introduced in Germany about eighteen years ago, and are now generally adopted throughout the cement world; the design of these mills has not materially altered since their introduction.

They are, subject to slight alterations, equally suitable for grinding wet or dry, hard or soft materials, and also for clinker.

From the moment the raw materials enter the mill until they are finished as cement, the object of the manufacturer is to preserve the mixture of the product, and undoubtedly the ball and tube mills do this. They are, in fact, mixers as well as grinders. The very simplicity of the principle of reduction by ball and tube mills is sufficient guarantee of their reliability, while the fact that all waste produced by the attrition between balls, pebbles, and cement is carried on into the product, helps to offset the wear and renewal account.

In modern practice it is generally agreed that the process of reduction must be a gradual one both for raw materials and clinker, and the ball and tube mills are ideal for this purpose since the former acts as the primary grinder for the latter. The materials are reduced just sufficiently by the sieves of the ball mill to ensure the finished product from the tube mill being of the required fineness.

Hence one of each class of mill should work together and be so arranged that the transfer of substances from one to the other

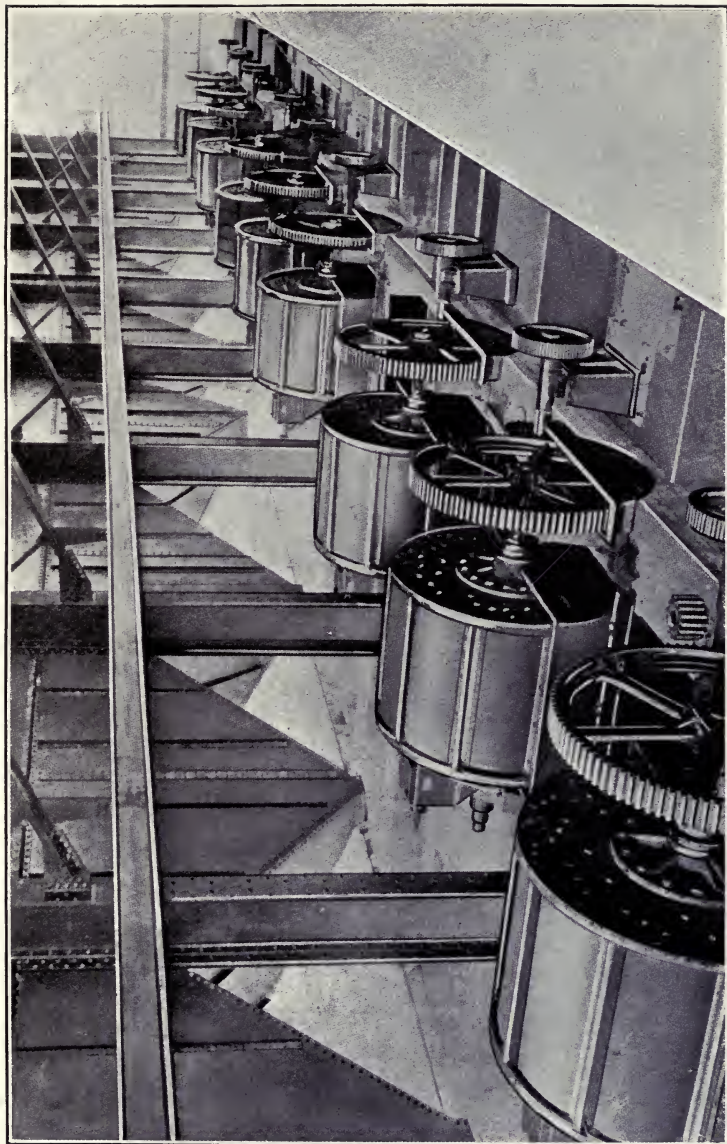

BATTERY OF BALL MILLS (ALLIS CHALMERS CO.).



BATTERY OF TUBE MILLS (ALLIS CHALMERS CO.).

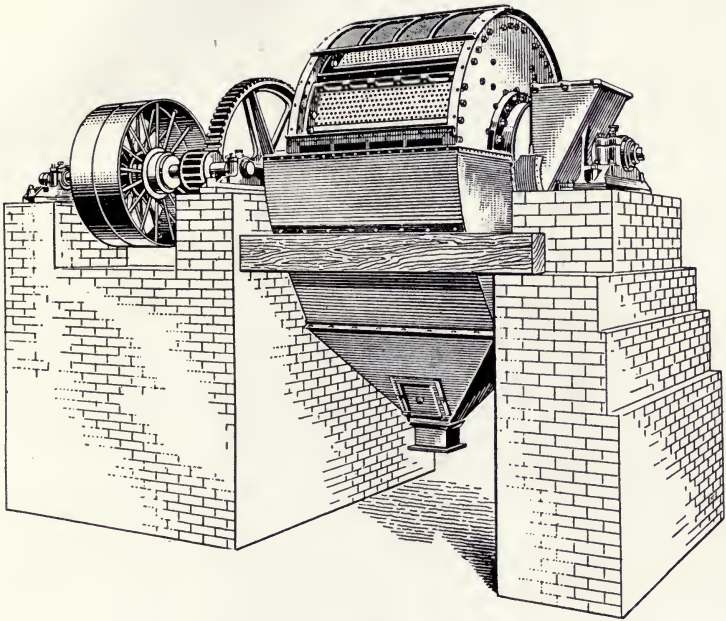

NEWELL'S LION BALL MILL.

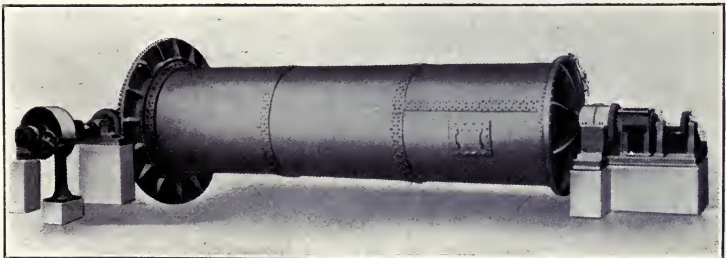

EDGAR ALLEN'S TUBE MILL.

PLATE XV.

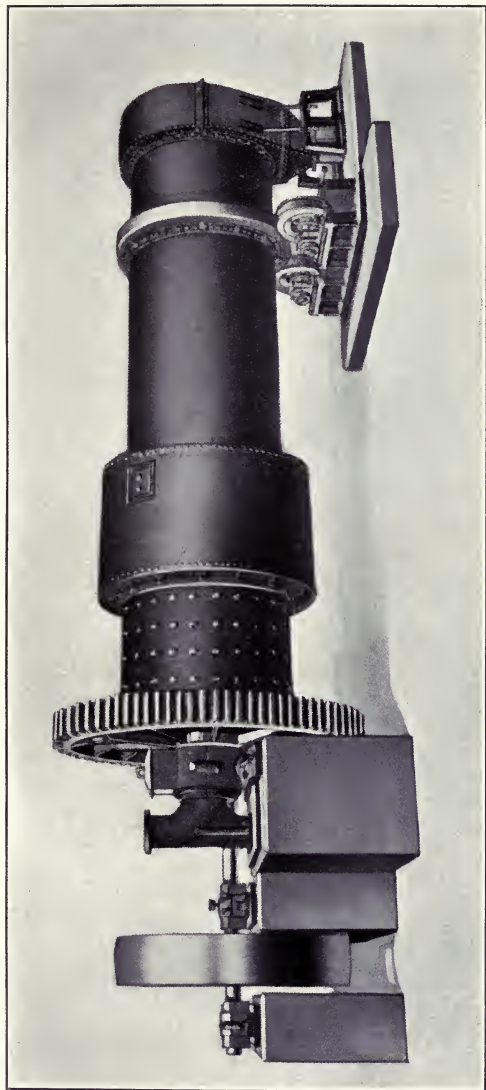

NEWELL'S CHAMBER GRINDING MILL.

[To face page 24.]

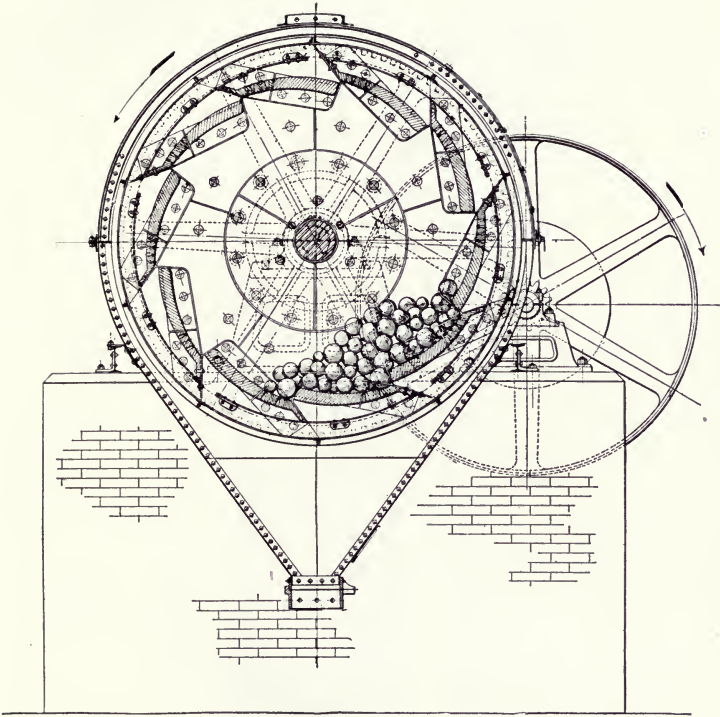

TRANSVERSE SECTION OF GATES' BALL MILL
(ALLIS CHALMERS CO.).

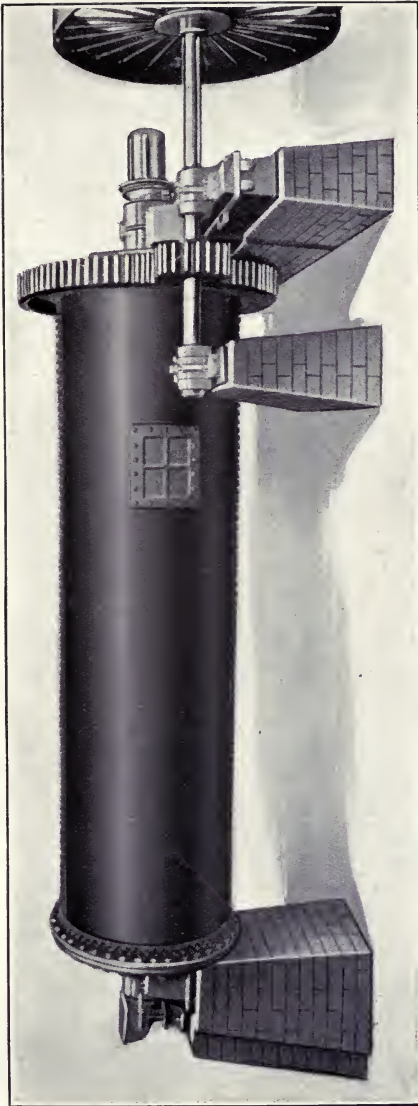

RIVETED TUBE MILL.

may be effected by gravitation, thus obviating the necessity of costly elevating and conveying machinery and of hoppers over the tube mills.

An absolute adjustment can be made by the miller to get the best results from both mills. If the requisite fineness is not obtained from the tube mill, when its condition is correct, that is, when it contains the proper number of pebbles, which, by the way, should be as near the centre as possible, he has only to replace the sieves of the ball mill by others of finer mesh and continue to do so till the desired fineness is achieved. To facilitate this, the millers should have a supply of sieves of various meshes near at hand in order to reduce to a minimum the time wasted in effecting these changes.

To produce good results, it is of the utmost importance that the materials should be regularly fed into the mill. This not only ensures sound production, but serves to lessen wear and tear, especially in the ball mill, where the steel balls, if allowed to fall on the steel grinding plates, will soon involve the manufacturer in an expensive account for repairs and renewals.

The best device for this purpose is the pan feed gear. Like all other really efficient machines, its extreme simplicity constitutes its chief recommendation.

The material to be ground gravitates on a slowly revolving plate, and, meeting an adjustable plough, is led off to the ball mill feed hopper, the angle of the plough governing the amount of material fed. An experienced miller can judge immediately by the "ring" of the mill when the proper feed is given, and also when the best work is being done.

Reduction by ball and tube mill is most reliable, and once the mills are properly balanced they require comparatively little attention. The material is fed in at the centre and falls amongst the balls of the former while the mill is revolving. These balls remain constantly at the bottom, gravitating from one plate to another as soon as sufficient incline is obtained from the rotation of the mill. The material is intermixed with these balls, and the attrition of the balls and the concussion due to their falling from one step to another reduce it to a powder which finds its way through perforations in the steel plates. It then falls on to a coarse grating, or inner sieve, which rejects everything which is not fine enough to pass through. Then, again, the finer portion of the material passes through the grating and falls on to another and still finer sieve, and everything small enough to pass through this passes on to the tube mill.

The material retained on these two sieves automatically finds its way back into the mill. This is brought about by the continuous revolution, the rejected particles re-entering through specially arranged scoops, and continuing through the same cycle

of operations till they are sufficiently fine to pass through the outer sieve and thence to the tube mill.

It would be difficult to give statements as to the efficiency of these mills and the horse-power required, so much depending on the nature of the material to be ground, the degree of preliminary crushing, and the fineness of the product required, but the subject is discussed under "Power Plants", p. 51.

GRIFFIN MILLS

The Griffin mill was designed about twenty-five years ago for the purpose of reducing all kinds of hard and refractory materials to a fine powder at one operation without the aid of auxiliary screening or separating appliances. It has been in constant use, and has been developed and improved from time to time as experience as shown to be necessary. It is particularly adapted for use where a very fine product is required. By its use at a single operation material can be reduced in the 30 in. size from $\frac{3}{4}$ in. to a fineness of 10 to 14 per cent residue on a sieve having 180 meshes per lineal inch, with a minimum expenditure of power, and the wear and tear cost is very low.

The peculiar action of the Griffin mill is effected by the positive rotation of the roll-head, by means of which it pulls itself around the die ring on which it runs and operates. The roll-head has a drawing action on the material, pulling it, so to speak, between the roll-head and the die ring, and exerting a crushing and abrading action which no other mill does. The roll-head is revolved within the die ring in the same direction that the shaft is driven, but when coming in contact with the die ring it travels around the die ring in the opposite direction from that in which the roll-head is revolving with the shaft, thus giving the mill two direct actions on the material to be ground. The crushing effect of the roll-head against the die ring in the 30 in. Griffin mill is over 6,000 pounds.

The Griffin mill is very largely used in the manufacture of Portland Cement in various parts of the world, and large numbers are in use pulverizing the raw materials—limestone, shale, clay, etc., cement clinker, and the coal which is used as fuel in the rotary kilns. Below is given data respecting the 30 in. Griffin mill pulverizing materials as used in the Portland Cement industry under ordinary working conditions.

Output.

On limestone and shale	$1\frac{3}{4}$ - $2\frac{1}{4}$	tons per hour.
On chamber kiln clinker.	$1\frac{1}{2}$ -2	„ „
On rotary cement clinker.	1 - $1\frac{1}{2}$	„ „
On coal	$1\frac{3}{4}$ - $2\frac{1}{4}$	„ „

LIST OF PARTS OF COMPOSITE FRAME GRIFFIN MILL.

- | | |
|---|--|
| <p>1. Shaft.</p> <p>2. Body of roll.</p> <p>3. Follower.</p> <p>4. Main carrying frame.</p> <p>5. Frame stay rods.</p> <p>6. Spider and fans.</p> <p>8. Nut for follower (for use with No. 3).</p> <p>9. Ball with trunnions.</p> <p>10. Nut for top of shaft.</p> <p>11. Gibs.</p> <p>12. Top shaft.</p> <p>13. Cover casting.</p> <p>14. Steel spring.</p> <p>15. Pressure ring.</p> <p>16. Body of pulley.</p> <p>17. Rim of pulley.</p> <p>18. Compression ring.</p> <p>19. Bearing ring.</p> <p>20. Cone bearing.</p> <p>21. Thrust rings—two of steel and two of composition.</p> <p>22. Top shaft brace.</p> <p>23. Wood standard.</p> <p>24. Body of mill or pan.</p> <p>25. Sheet-iron cone—rear half.</p> <p>25a. Sheet-iron cone—front half.</p> <p>26. Conical bushing.</p> <p>27. Straight bushing.</p> <p>28. Bolts for ring wedges.</p> <p>29. Steel wearing plates in pulley.</p> <p>30. Feeder standard.</p> <p>31. Tire for roll.</p> <p>32. Feed chute.</p> <p>33. Cover support.</p> <p>34. Bolt for top brace.</p> <p>35. Pulley cover stud bolts.</p> <p>37. Cone bearing set bolt.</p> | <p>38. Screen frame.</p> <p>40. Feeder pulley.</p> <p>41. Feeder shaft.</p> <p>42. Feeder shaft top bearing.</p> <p>42½. Cap for feeder shaft bearing.</p> <p>43. Rear cover.</p> <p>44. Front cover.</p> <p>45. Sheet-iron cover.</p> <p>46. Clamp for cover.</p> <p>47. Clamp with bolt.</p> <p>48. Wedge for 30 in. ring.</p> <p>49. Feed screw.</p> <p>50. Feed hopper.</p> <p>51. Feed slide.</p> <p>52. Feed cover.</p> <p>53. Feed screw shaft.</p> <p>54. Feeder shaft lower bearing.</p> <p>55. Body of feeder.</p> <p>56. Bracket bearing for feed screw shaft.</p> <p>57. Shifter arm.</p> <p>58. Shifter standard.</p> <p>59. Clutch.</p> <p>60. Pinion with clutch.</p> <p>61. Bevel gear of feeder.</p> <p>62. Lock washer for No. 63.
Lock washers for No. 28.</p> <p>63. Frame bolts.</p> <p>64. Rubber washer for stay rods.</p> <p>65. Rubber block under standard.
Rubber washers for cover supports, No. 33.</p> <p>66. Standard socket.</p> <p>70. Steel ring or die.</p> <p>71. Ball joint for No. 42.</p> <p>72. Chilled iron roll-head, 18 in. diam.</p> <p>73. Nut for chilled iron roll-heads.</p> |
|---|--|

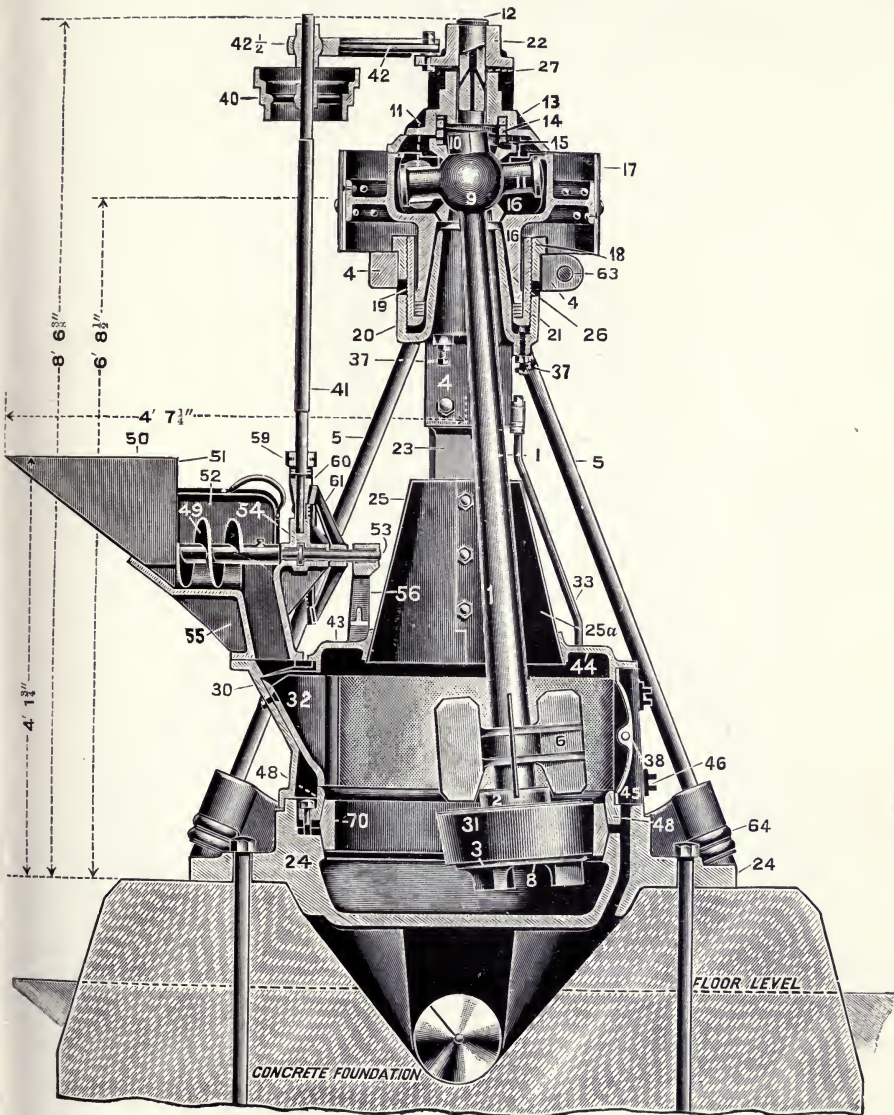

COMPOSITE FRAME GRIFFIN MILL (SECTIONAL VIEW).

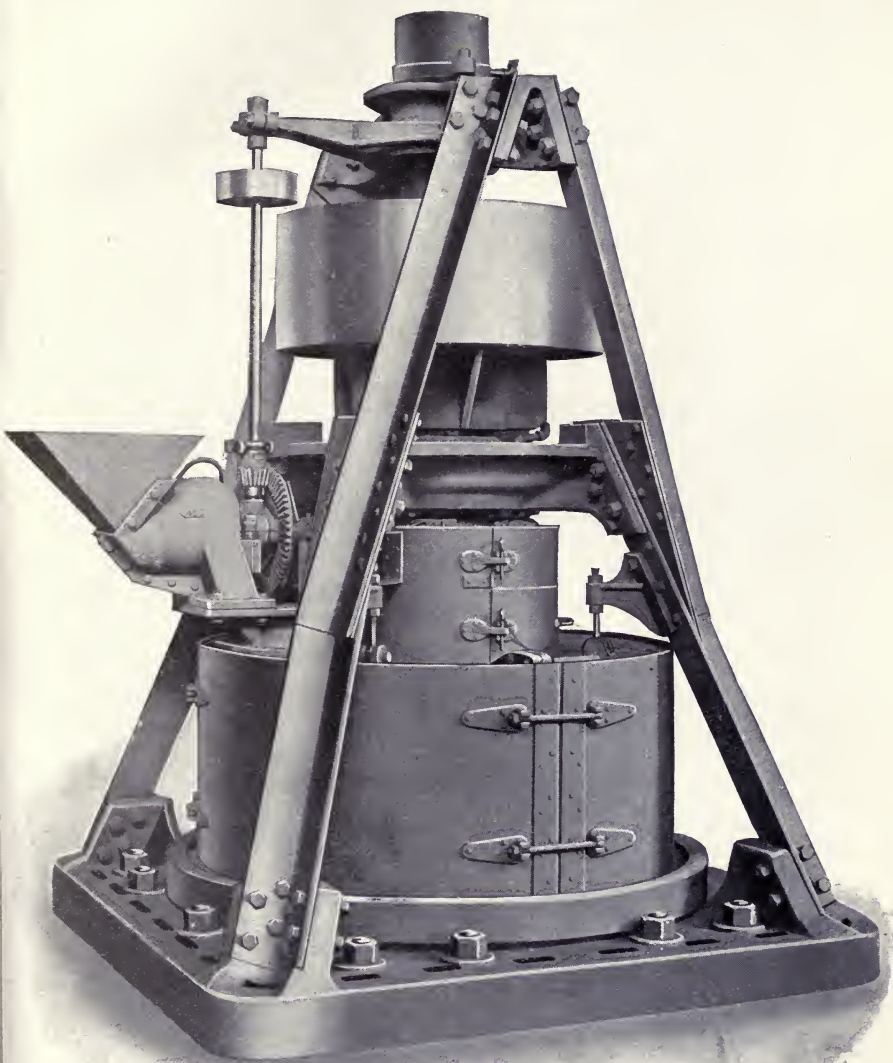

THE 40 IN. GIANT GRIFFIN MILL.

Fineness.—When giving the above-named outputs the fineness is 12 to 14 per cent residue on a sieve having 180 meshes per linear inch.

Any desired fineness of grinding may be obtained from the Griffin mill, it being simply arranged for by changing the mesh of the screen which is fitted around the pan of the mill; the output will then slightly increase or decrease accordingly.

Horse-power.—When doing the above output the 30 in. Griffin mill requires 25 to 28 h.p. applied to the pulley at the head of the mill.

Size of Feed and Moisture.—The material should be fed in pieces up to $\frac{3}{4}$ in. in size and for best results 2 per cent of moisture should not be exceeded.

The latest form of 30 in. Griffin mill is that of the composite wood and iron frame type. This style is made with wooden standards, which rest on rubber blocks, thus giving a large measure of elasticity to the framework, and cushioning the severe vibratory strains which are necessarily set up in a pulverizing mill. During the last year or two substantial improvements have been made in the design and construction of the machine, so that the Griffin mills now being sold are better in many ways than those made several years ago. Larger bearing surfaces for the wearing parts, providing more fully for the heavy strains when grinding the hard material, have been adopted.

40 IN. GIANT GRIFFIN MILL

The greatest development of the Portland Cement industry in recent years has resulted in the construction of immense works in various parts of the world, which necessitates the machinery being in larger units. To meet this demand the 40 in. giant Griffin mill was specially designed and constructed, and has been on the market for some time with excellent results. It embodies the experience gained over the past twenty-five years in the manufacture of cement-pulverizing machinery, and shows a marked increase in efficiency, both as power required to operate it and in the fineness of product produced. The principle of the giant Griffin mill is similar to that of the 30 in. Griffin mill on a heavier and more substantial scale, and the crushing effect of the roll-head against the die ring amounts to about 15,000 pounds.

The 40 in. giant Griffin mill has 2 to $2\frac{1}{2}$ times the capacity of the 30 in. Griffin mill to a better fineness, for a horse-power consumption of 60 to 65 b.h.p. applied to the pulley. Material can be fed to this mill in pieces up to $1\frac{1}{2}$ in. size, and a finished product to any desired fineness is obtained at one operation.

The following tests were made at one of the largest English cement works where giant Griffin mills are in operation both on the raw material and clinker sides, and these tests were made under every-day running conditions.

	On Rotary Clinker.	On Raw Materials, Limestone, and Shale.
Output per hour	49½ cwt.	83 cwt.
Residue on 180 mesh sieve	14%	10%
" 100 " " " 	1.75%	1.45%
" 76 " " " 5%	1.4%
Percentage of flour (tested on Gorham's Flourometer)	48%	—
h.p. applied to mill pulley	71.5	54
h.p. per ton (ground)	29	13
Screen on mill	40 mesh.	40 mesh.
Size of feed	1½" down.	1½" down.
Condition of roll-head	Half worn-out.	New.
Condition of die ring	Quarter worn-out.	New.

In the above cases of clinker grinding it must be remembered the cement clinker was very hard, one of the hardest clinkers produced in this country.

BRADLEY THREE-ROLL MILL

The improved Bradley three-roll mill continues to do excellent pulverizing work on raw materials; limestone and shale, on softer clinkers (it is not recommended for rotary cement clinker) and on coal, etc. Large numbers are installed in cement works, and the following data respecting this mill will be useful:—

Output.

On limestone and shale . 3-4 tons per hour.
On chamber kiln clinker. 2½-3½ " "
On coal 3-4 " "

Fineness.—When giving the above-named outputs the fineness is 14 to 16 per cent residue on a 180 mesh sieve.

Horse-power.—45 to 55 b.h.p. applied to the mill pulley.

Size of Feed and Moisture.—Material should be fed in $\frac{3}{4}$ in. pieces, and the moisture should not exceed 2 per cent for best results.

The Bradley three-roll mill is specially recommended for pulverizing coal for use as fuel in rotary kilns, and is very popular for this and similar work.

Specially Fine Grinding.—Where a specially fine and floury product is required, the "Carr-Hill" patent conical baffle can be fitted, which has been used with very great success; the percentage of residue left on a 180 mesh sieve has been greatly decreased, and it also tends to greatly increase the percentage

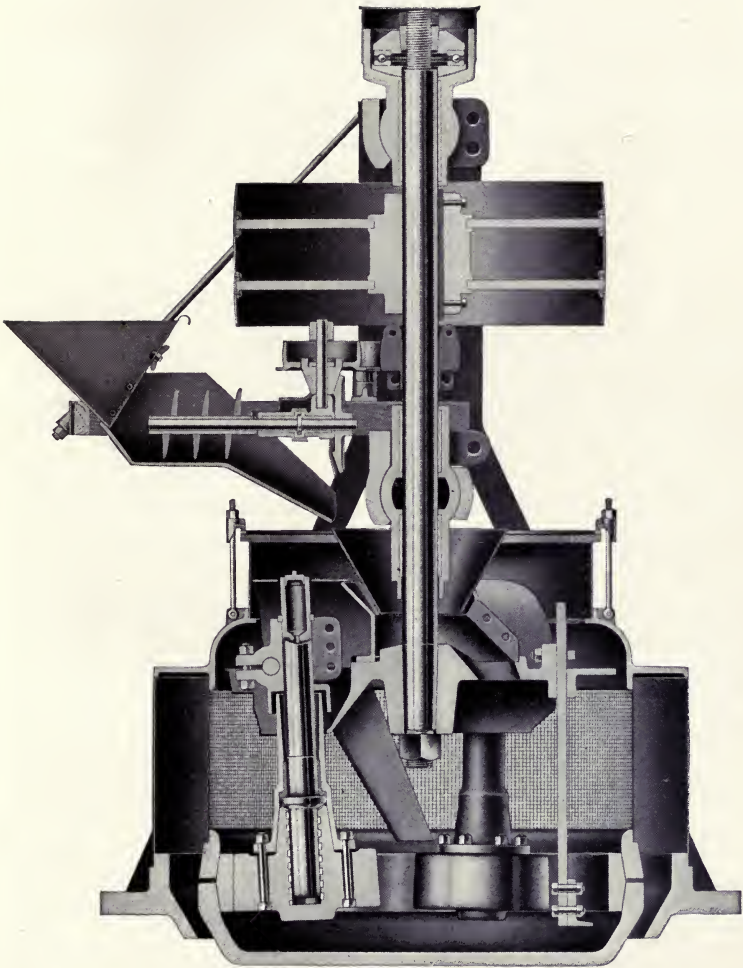

BRADLEY THREE-ROLL MILL.

of flour or impalpable powder in the ground product, flour tests made on ground cement with Gorham's standard flourometer showing as high as 60 to 62 per cent flour. This extra fineness and percentage of flour applies equally when grinding cement clinker, raw material, and coal, and has the following effects:—

- (1) When grinding cement clinker much better test results are obtained on the finished cement, especially in the sand tests.
- (2) When grinding raw materials, a finer ground product means a better quality cement clinker, more evenly burnt, and a reduction in the kiln coal consumption.
- (3) In the case of coal grinding, it means a much cleaner and more regular flame with a resulting increase in output from the kiln and decrease in the amount of coal burnt per ton of cement clinker produced.

CENTRIFUGAL BALL MILL

THE FULLER-LEHIGH PULVERIZER MILL

Fan Discharge Type

The material to be reduced is fed to the mill from an overhead bin by means of a feeder mounted on top of the mill. This feeder is driven direct from the mill shaft by means of a belt running on a pair of three-step cones, which permits the operator to accommodate the amount of material entering the mill to the nature of the material being pulverized. In addition the hopper of the feeder is provided with a slide, which permits the operator to increase or decrease the amount of material entering the feeder hopper.

The material leaving the feeder enters the pulverizing zone of the mill. The pulverizing element consists of four unattached steel balls, which roll in a stationary, horizontal, concave-shape grinding ring. The balls are propelled around the grinding ring by means of four pushers attached to four equidistant horizontal arms forming a portion of the yoke, which is keyed direct to the mill shaft. The material discharged by the feeder falls between the balls and the grinding ring in a uniform and continuous stream, and is reduced to the desired fineness in one operation.

It will be noticed that fan discharge mills are fitted with two fans. One of these fans operates in the separating chamber immediately above the pulverizing zone, whereas the other fan operates in the fan housing immediately below the pulverizing zone. The upper fan lifts the fine particles of pulverized material from the grinding zone into the chamber above the grinding zone, where these fine particles are held in suspension. The lower fan acts as an exhauster, and draws the finely divided particles through the finishing screen which completely encircles the separating

chamber. The material leaving the separating chamber is drawn into the lower fan housing, from which it is discharged through the discharge spout by means of the fanning action of the lower fan. All the material discharged from the mill is finished product and requires no subsequent screening.

The current of air induced by the action of the lower or discharge fan passes over the pulverizing zone and out through the screen surrounding the separating chamber, thus ensuring cooler operation and maximum screening efficiency. This current of air keeps the screen perfectly clean, and enables the mill to handle material containing a considerable amount of moisture without in any way affecting the efficiency of the machine.

When the mill is in operation it is continually handling only a limited amount of material at any one time. As soon as the material is reduced to the desired fineness it is lifted out of the pulverizing zone and discharged from the machine. It is therefore evident that, inasmuch as the crushing force is being applied to only a limited amount of material, the power required to operate the machine is reduced to a minimum, and is furthermore applied directly to the material being pulverized.

This shows that the machine possesses maximum mechanical efficiency, which, coupled with the fact that it is economical in cost of installation, operation, and maintenance, proves conclusively that the Fuller mill is an ideal pulverizer mill, eminently well suited for the production of finely ground material containing a high percentage of impalpable powder.

PRELIMINARY PREPARATION OF MATERIAL FOR MILL FEED

Some provision should be made to prepare the lump material before it is fed to the pulverizer mill, in order to make certain that the mill will not be subjected to service for which it is not intended. Materials differ widely in physical structure and chemical characteristics. Some materials occur in massive form and must be crushed to suitable size before they can be pulverized. Other materials contain an excessive amount of free moisture, which must be driven off before a finely powdered product can be obtained. It is therefore evident that some system of preliminary preparation should be provided, either crushing, drying, or both crushing and drying, to ensure the most efficient results relative to capacity, power, quality of product, and maintenance.

CRUSHING

Material fed to the various sizes of Fuller mills should be broken down as follows:—

	Soft and Medium Hard Rock.	Hard Rock.
33" mill	Through $\frac{3}{4}$ " ring.	Through $\frac{3}{8}$ " ring.
42" "	" 1" "	" $\frac{3}{4}$ " "
57" ,, (Dreadnought)	" 1 $\frac{1}{4}$ " "	" 1 $\frac{1}{2}$ " "

LIST OF PARTS OF 42 IN. FULLER-LEHIGH PULVERIZER MILL

Fan Discharge Type—42 in. or 45 in. diameter Driving Pulley

Name of Part.	Designating Number.	Name of Part.	Designating Number.
Base	D 4000	Discharge port cover	D 4026
Bottom section	D 4042	Bottom bearing	D 4027
Fan housing	D 4045	Bushing for bottom bearing	D 4028
Intermediate section	D 4046	Dust-cap, bottom bearing	D 4029
Top section	D 4003	Intermediate bearing (two halves)	D 4030
Top cover plate, right hand	D 4004	Bushing for intermediate bearing (two halves)	D 4031
Top cover plate, left hand	D 4005	Clamp for intermediate bearing (two halves)	D 4032
Discharge fan	D 4007	Top bearing	D 4033
Yoke	D 4008	Bushing for top bearing	D 4028
Yoke support	D 4009	Dust-cap for top bearing	D 4029
Dust collar for yoke	D 4010	Lid for ventilating opening	D 4036
Grinding ring	D 4011	Driving pulley, 42 in. diameter	D 4038
Pusher, single face, closed end	D 4016	Driving pulley, 45 in. diameter	D 4039
Pusher, single face, with scoop	D 4017		
Ball	D 4018		
Discharge spout	D 4022		

Feeder Parts

Conveyor stand, right hand	D 4050	Bushing for bracket bearing	D 4063
Conveyor stand, left hand	D 4051	Feeder pinion	D 4064
End cover for conveyor stand	D 4052	Feeder gear	D 4065
Top cover for conveyor stand, right hand	D 4053	Feeder pinion shaft	D 4066
Top cover for conveyor stand, left hand	D 4054	Feeder gear shaft	D 4067
Caps for stand bearing	D 4055	Feeder screw, right hand	D 4068
Bushing for stand bearing	D 4056	Feeder screw, left hand	D 4069
Bushing for tail bearing	D 4057	Feeder cone pulley on mill shaft (specify material ground)	D 4071
Feeder hopper	D 4058	Feeder cone pulley on mill shaft (specify material ground)	D 4072
Feeder hopper slide	D 4059	Feeder cone pulley on pinion shaft	D 4073
Feeder pinion bracket, right hand	D 4060	Grease cup for bracket bearing	D 4074
Feeder pinion bracket, left hand	D 4061	Grease cup for stand bearing	D 4075
Caps for feeder pinion bracket	D 4062		

Sundry Parts

Mill shaft	D 4083	Perforated protecting screens, rectangular opening	D 4093
Spud for mill shaft	D 4085	Finishing screen (specify material ground)	D 4094
Step block for mill shaft	D 4086	Screen band	D 4095
Fan centre (specify if right or left hand and material ground)	D 4087	Screen band brackets	D 4096
Top fan blades (specify if right or left hand and material ground)	D 4088	Outside casing	D 4097
Bottom fan blades (specify if right or left hand and material ground)	D 4089	Casing brackets, pin end	D 4098
Top fan brackets (specify if right or left hand and material ground)	D 4090	Eye bolt for outside casing	D 4099
Bottom fan brackets (specify if right or left hand and material ground)	D 4091	Pusher pin	D 4100
Perforated protecting screens, square opening	D 4092	Washer for yoke support	D 4101
		Pin for yoke support	D 4102
		Central drum	D 4103
		Grease cup for top bearing	
		Grease cup for intermediate bearing	
		Oil cup for bottom bearing	

[To face page 30.]

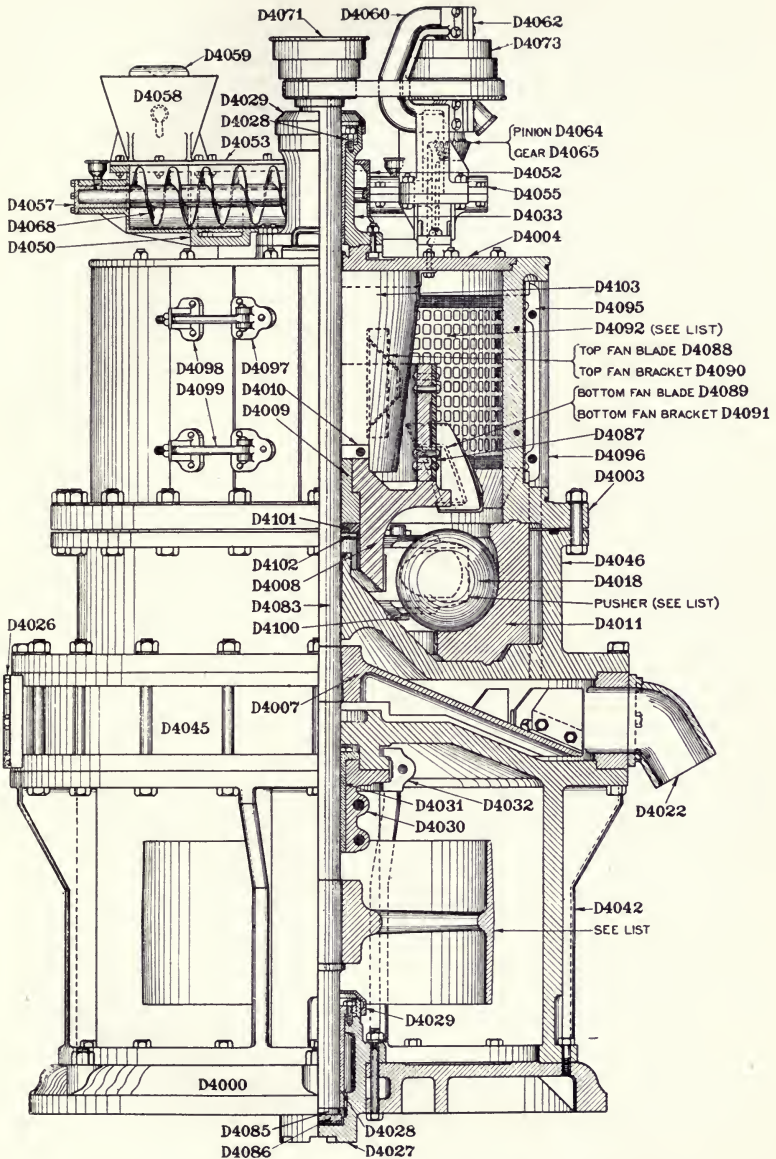

THE FULLER-LEHIGH PULVERIZER MILL (42 IN. FAN DISCHARGE TYPE).

Preliminary crushing for Fuller mill feed may be effected by means of rotary fine crushers, roll crushers, hammer mills, or ball mills. The product discharged by any of these types of crushers will be suitable feed for Fuller mills.

A mixed feed containing all the various particles resulting from reducing the material to the sizes mentioned above is the most satisfactory feed. For example, when crushing to $\frac{3}{4}$ in. ring size the run of the crusher will contain $\frac{3}{4}$ in., $\frac{1}{2}$ in., $\frac{1}{4}$ in., and $\frac{1}{8}$ in. particles, together with some dust. This feed, when delivered to the pulverizer mill, is distributed in a uniform layer over the entire surface of the grinding ring, renders the grinding element most efficient, and consequently produces the best results.

The capacities of the 33 in., 42 in., and 57 in. mills, when pulverizing coal, raw cement material, and Portland Cement clinker, are as follows:—

	33" Mill.	42" Mill.	57" Mill.
Diameter of driving pulley	32" × 12"	45" × 18"	75" × 23"
Speed of mill	210 r.p.m.	160 r.p.m.	130 r.p.m.
Size of feed	$\frac{3}{4}$ "	$\frac{3}{4}$ "	1 $\frac{1}{4}$ "
Capacity (tons), coal per hour	2-2 $\frac{1}{2}$	4-5	8-10
Power	30 h.p.	45 h.p.	90 h.p.
Capacity (tons), raw material per hour	2 $\frac{1}{2}$ -3	5-6	9-12
Power	40 h.p.	55-65 h.p.	110-125 h.p.
Capacity (barrels), cement per hour	—	10-14	20-30
Power	—	65-75 h.p.	135-150 h.p.

The above capacities are based on the assumption that the fineness of the finished product is such that 95 per cent will pass through a 100 mesh sieve and 85 per cent through a 200 mesh sieve.

STURTEVANT "RING ROLL" MILL

DESCRIPTION AND OPERATION

A heavy steel anvil ring is secured in a head supported and revolved by the horizontal shaft. Against the inner face of this ring hammer rolls are elastically pressed with great force and revolved by the ring.

Substances to be ground are fed (up to 1 $\frac{1}{4}$ in. sizes) to the inner face of the rotating ring and held thereon by centrifugal force to be crushed as drawn under the rolls. The face of the ring is concave, and the roll faces convex.

The roll mountings are on the massive door that forms one side of the mill casing, and are swung away from the ring with the door when it is opened. The roll shafts are as large as those of the driving wheels of a locomotive, and crushing pressures

are greater. One adjusting screw on the outside of the door regulates the roll forces and gives the rolls an absolutely equal pressure of from 20,000 to 40,000 lb.

Ring protected by Layer of Material

When at work, the concave of the revolving ring is always covered with a thick layer of material fed thereto. A naked track is never exposed to the roll faces. Rock is crushed down upon itself (between anvil ring and hammer roll), producing a maximum of fines, with least wear.

As there is a constant feed while the mill is at work of coarse and partly reduced material, so there is a constant drop of material crushed off of both sides of the ring by the rolls. This escapes, as in all mills of this class, from the bottom of the case, and is taken to a Sturtevant-Newaygo screen to remove the finished product as soon as made. The tailings, separated by this most effective of all screens, are returned to the ring (with fresh feed) for further reduction. Thus the mill is always breaking down tailings and coarse rock upon each other and producing a maximum output.

As the ring's anvil surface is always protected by a thick covering of rock, held thereon by centrifugal force, and the hammer rolls strike the coarse fresh rock down upon this coating, it is fair to assert that ring-roll mills almost completely compel rocks to crush one another.

The enormous crushing pressures already mentioned (which are greater than the track pressures of locomotive wheels) are safe with the high-power steel axles of the Sturtevant mill. These elastically and equally pressed rolls are balanced and pass over iron or uncrushable substances with shocks so completely cushioned that crystallization or shaft breakage is prevented.

“OPEN DOOR” ACCESSIBILITY

This important improvement particularly distinguishes many Sturtevant mills. The whole front of this mill case opens like the massive door of a safe, and carries the rolls and all their parts entirely outside of the mill, exposing the whole interior. The ring, which is the only working part left inside, can be quickly reached. When the door closes it swings the rolls back into the interior space of the ring, and then all three rolls may be equally and elastically pressed by one screw, on the outside of the door, against the ring face as strongly as is needed to crush any grindable material put on the ring. The ring discharges its rock on both sides of the concave track. Ability to open the door quickly saves time, an important consideration even in small works. The mill case has other openings too that are convenient for quick inspection.

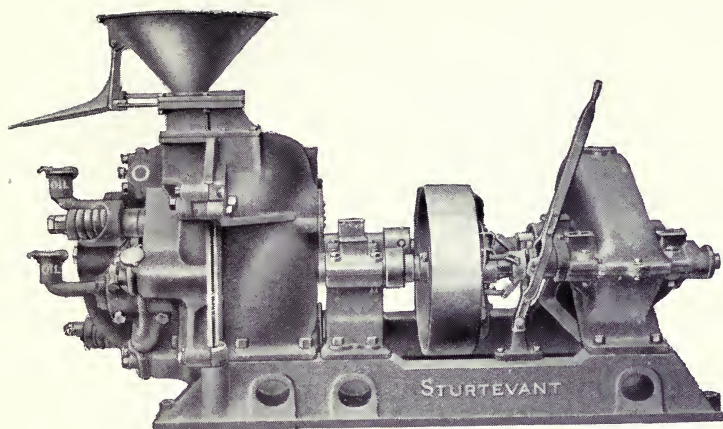

RING-ROLL MILL.

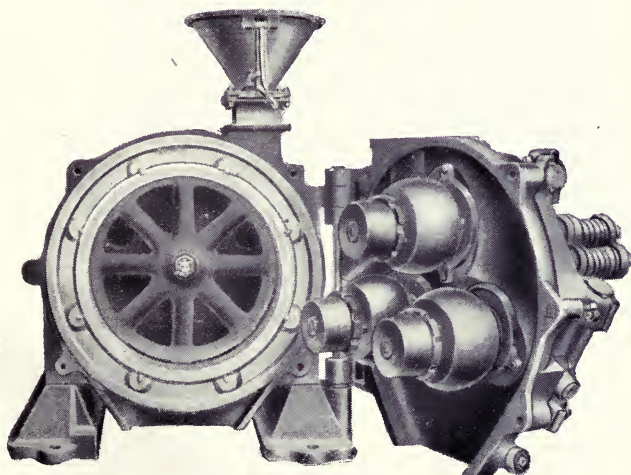

RING-ROLL MILL (ACCESSIBILITY).

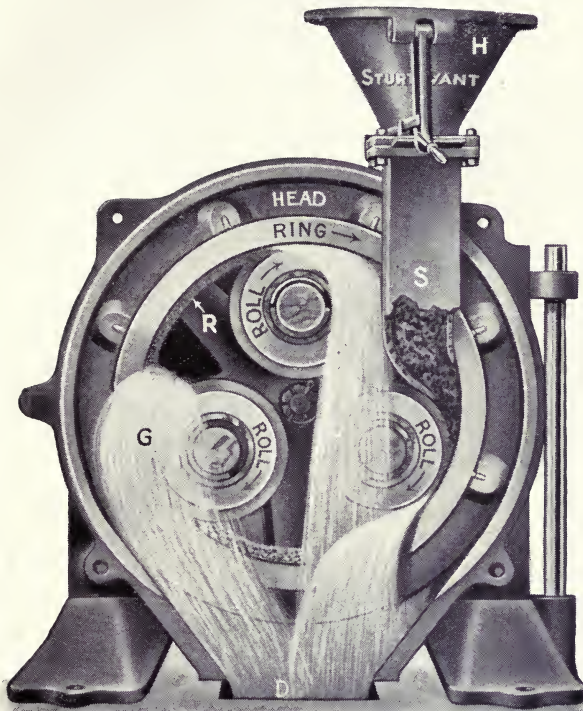

RING-ROLL MILL (DESCRIPTION AND OPERATION).

Feed enters hopper at "H".

Spout "S" delivers it at centre of concave revolving ring, where it is strongly held by centrifugal force until crushed off by the rolls, discharging at "D".

Ground rock crushed off of both sides of ring, "G."

Thick layer of centrifugally held unground rock, "R."

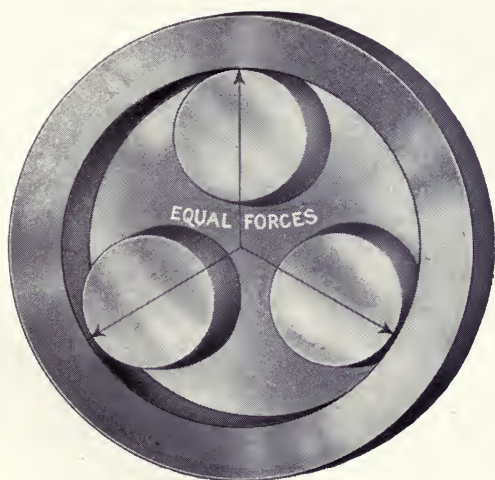
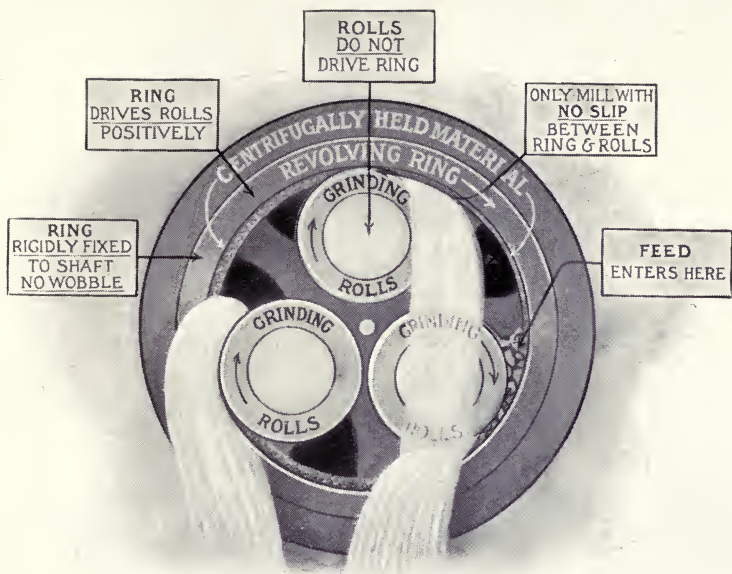

RING-ROLL (DESCRIPTION AND OPERATION).

[To face page 32.]

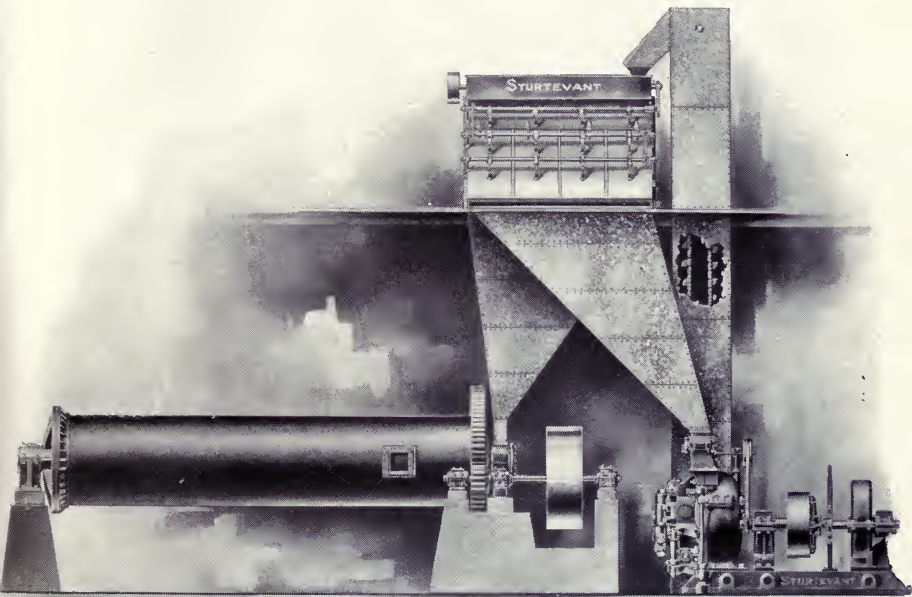

CEMENT GRINDING UNIT FOR ROTARY AND CHAMBER CLINKER.

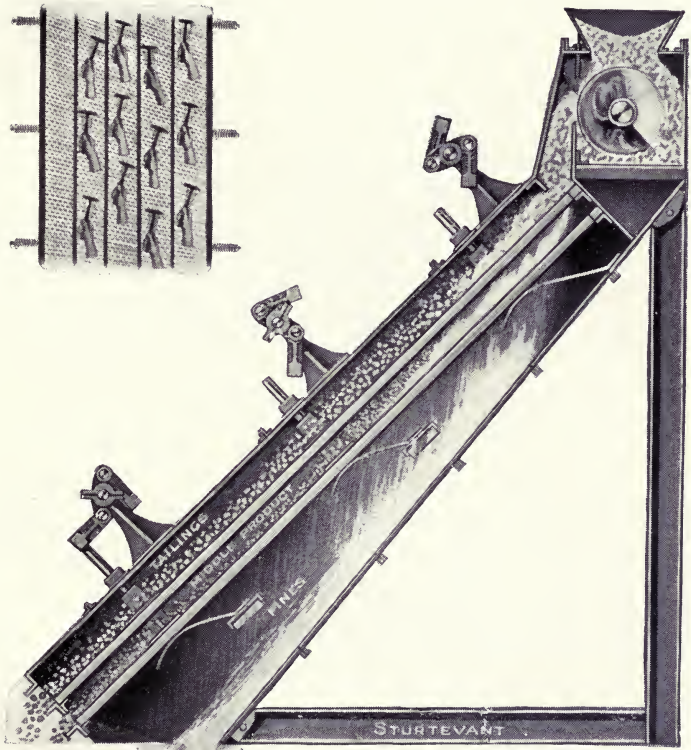

A DOUBLE STURTEVANT-NEWAYGO SCREEN IN ACTION.

The three rolls are supported with abundant strength by the massive door. Each roll is swung into immense and equal elastic crushing pressures by its spring-actuated steel bell lever. The comparative strength of a Startevant mill is shown by its steel material and weight. Either roll can be removed and replaced in a few minutes—because no shaft has to be disturbed.

The rolls of the mill may be held away from the ring when the ring runs empty, because they do not support it. This is a considerable advantage. The naked surfaces of ring and rolls would otherwise at this time injure each other as they do in other mills, when allowed to run empty.

CAPACITY OF VARIOUS MACHINES USED FOR CRUSHING, GRINDING, AND CONVEYING

The following figures will probably be found useful to those interested in cement plants, and give some idea of the output and power consumption, etc., of the chief machines in use. In all instances it must be understood that the figures are approximate only, as they are to a large extent dependent upon the class of material dealt with, the regularity with which the raw material is fed into the machine, and the fineness, or otherwise, of the finished product:—

¹ Gyratory Crushers

Size of Crusher.	Size of each Feed Opening.	Finest Setting.		Coarsest Setting.		Size of Driving Pulley.	Revolutions per Minute.	Horse-power required.	Approx. Weight of Crusher.
		Smallest Size of Product.	Capacity in Tons 2,000 lb. per Hour.	Largest Size of Product.	Capacity in Tons 2,000 lb. per Hour.				
No.	inches.	in.	tons.	in.	tons.	inches.	No.	No.	lb.
1	5 × 20	$\frac{7}{8}$	4 $\frac{1}{2}$	1 $\frac{1}{4}$	8 $\frac{1}{2}$	24 × 6	475	4- 6	7,000
2	6 × 25	1	6 $\frac{1}{2}$	2 $\frac{1}{4}$	12 $\frac{1}{2}$	24 × 8	450	6- 10	10,300
3	7 × 28	1 $\frac{1}{4}$	11	2 $\frac{3}{4}$	25	28 × 10	425	10- 15	17,000
4	8 × 34	1 $\frac{1}{2}$	20	3 $\frac{1}{2}$	48	32 × 12	400	12- 20	23,000
5	10 × 40	1 $\frac{3}{4}$	30	4 $\frac{1}{4}$	75	36 × 14	375	20- 25	37,000
6	12 × 44	2	50	4 $\frac{1}{2}$	120	40 × 16	350	25- 40	48,500
7 $\frac{1}{2}$	15 × 55	2 $\frac{1}{2}$	80	5	180	44 × 18	350	45- 70	72,000
8	18 × 68	2 $\frac{3}{4}$	110	5 $\frac{1}{2}$	250	48 × 20	350	65-100	100,000
9	21 × 76	3	160	6	350	56 × 20	325	100-140	160,000
10	24 × 84	3 $\frac{1}{2}$	210	6 $\frac{1}{2}$	450	56 × 24	325	115-160	180,000
11	27 × 92	4	260	7	550	56 × 24	325	130-180	200,000
18	36 × 130	5	600	8	1,100	72 × 31	280	200-250	425,000
21	42 × 136	5 $\frac{1}{2}$	700	9	1,300	72 × 33	280	225-280	475,000
24	48 × 148	6	850	10	1,600	84 × 33	250	250-325	600,000

¹ Traylor Engineering and Manufacturing Co., New York.

¹ Small Jaw Crushers

Size of Opening.	Capacity in tons per hour.	H.P.	Pulley.	R.P.M.	Weight.
inches. 10 × 7	inches. 4 to 1½	8	inches. 20 × 7½	300	8,000
20 × 6	7 ,, 1½	12	30 × 7½	300	14,000
16 × 10	7½ ,, 1½	15	30 × 9	300	16,500
20 × 10	10 ,, 1½	20	30 × 12	300	20,000
24 × 13	20 ,, 2	30	42 × 13	300	30,000
24 × 15	20 ,, 2	32	42 × 13	300	32,000
30 × 15	25 ,, 2	40	42 × 15	300	38,000
30 × 18	25 ,, 2	42	42 × 15	300	45,000
36 × 18	45 ,, 2½	65	42 × 19	300	60,000
36 × 24	45 ,, 2½	75	48 × 20	300	80,000
36 × 30	48 ,, 2½	80	48 × 22	250	85,000
42 × 30	72 ,, 3	100	54 × 22	250	130,000

¹ Large Jaw Crushers

Size of Opening.	Capacity in tons per hour.	H.P.	Pulley.	R.P.M.	Weight.
inches. 60 × 30	inches. 115 to 3	135	inches. 72 × 21	200	180,000
72 × 30	135 ,, 3	150	78 × 21	200	210,000
42 × 36	100 ,, 4	110	54 × 22	200	170,000
48 × 36	115 ,, 4	135	54 × 24	200	200,000
60 × 36	200 ,, 5	140	72 × 22	200	220,000
48 × 42	200 ,, 6	140	66 × 24	175	210,000
60 × 42	250 ,, 6	150	72 × 24	175	230,000
60 × 48	325 ,, 7	175	72 × 26	150	260,000
84 × 60	600 ,, 8	250	132 × 36	90	450,000

¹ Crushing Rolls

Size.	Approximate Capacity tons per hour.	R.P.M. of Rolls.	Stationary Roll.	Movable Roll.	H.P. required.	Weight.
Diam. Face. inches.	in.		Diam. Face. inches.	Diam. Face. inches.		lb.
72 × 36	170 to ¾	45	108 × 30	72 × 18	115	190,000
72 × 24	115 ,, ¾	45	108 × 24	72 × 14	85	150,000
60 × 30	80 ,, ¾	50	96 × 24	60 × 14	90	140,000
54 × 24	50 ,, ¾	60	84 × 18	42 × 14	65	85,000
48 × 20	35 ,, ¾	60	84 × 16	42 × 12	50	65,000
42 × 16	18 ,, ¾	70	84 × 14	42 × 10	40	36,000
36 × 16	13 ,, ¾	70	72 × 14	36 × 8	25	28,000
30 × 14	10 ,, ¾	80	60 × 12	30 × 6	15	19,500
18 × 10	5 ,, ¾	150	36 × 6	18 × 4	8	8,000

¹ Traylor Engineering and Manufacturing Co., New York.

The face of the rolls should always be arranged to meet the requirements of the class of material to be handled ; some of the types met with in practice are as follows :—

Smooth rolls are generally used for rotary clinker and materials of a similar nature, such as slag, etc.

Corrugated rolls having the grooves arranged obliquely are often used for materials similar to limestone.

Toothed rolls are suitable for material of the nature of coal, gypsum, chalk, etc.

Point and cutter rolls may be used for coal, coke, etc., and where the product is required to have the least amount of grit.

Steel Ball Mills (Wet Grinding)

Size of Mill.			Driving Pulleys.			Weight of Steel Balls.	Output per hour. Limestone.	B.H.P.
Diam. ft. in.	Length. ft. in.	R.P.M.	Diam. in.	Width. in.	R.P.M.	tons.	tons.	
4 0	11 6	30	72	12	160	6	4	40
4 6	13 0	28	84	14	140	10	6	75
5 6	15 0	25	96	15	125	15	8	100
9 0	6 0	23	96	22	130	15	10	150

Preliminary mill for grinding material similar to limestone. Output based on weight of raw material fed into mill. Product to contain 38 per cent moisture and pass 40 × 40 mesh per square inch.

Steel Ball Tube Mills (Wet Grinding)

Size of Mill.			Driving Pulleys.			Weight of Steel Balls.	Output per hour. Limestone.	B.H.P.
Diam. ft. in.	Length. ft. in.	R.P.M.	Diam. in.	Width. in.	R.P.M.	tons.	tons.	
3 6	18 0	34	72	12	170	6	4	40
4 0	22 0	30	84	16	150	10	6	60
4 6	26 0	28	96	18	140	15	8	100
6 0	26 0	28	96	20	160	22	11	150

Finishing mill for grinding material similar to limestone. Output based on weight of raw material fed into preliminary mill. Product to contain 38 per cent moisture, and residue not to exceed 10 per cent on 180 × 180 mesh per square inch, calculated on the dried slurry.

The above type of finishing mill may, instead of being provided with steel lining plates and steel grinding balls, be arranged with quartz or silex lining and flint pebbles as the grinding medium, in which case the outputs will be somewhat reduced. The size of mill in this case for the same output per hour would generally be about 12 inches larger in diameter.

"Ball Mills" (Preliminary Mill Dry Grinding)

Size of Mill.			Driving Pulleys.			Weight of Steel Balls.	Output per hour.		B.H.P.
							Coal 60×60 sieve.	Rotary Clinker 75×75 sieve.	
Diam. ft. in.	Width. ft. in.	R.P.M.	Diam. in.	Width. in.	R.P.M.	wt.	tons.	tons.	
3 6	2 9	30	30	4	120	5	$\frac{1}{2}$	$\frac{1}{4}$	2 $\frac{1}{2}$
4 6	3 0	30	36	5	120	8	$\frac{3}{4}$	$\frac{1}{2}$	5
5 6	3 6	27	42	6	135	12	1	$\frac{3}{4}$	7 $\frac{1}{2}$
6 6	4 0	27	48	7 $\frac{1}{2}$	135	16	1 $\frac{1}{2}$	1	12 $\frac{1}{2}$
7 6	4 6	25	54	9	150	25	2	1 $\frac{1}{2}$	20
8 6	5 6	21	66	10	125	40	3	2	30
9 6	6 0	21	72	12	125	55	4 $\frac{1}{2}$	3	40
10 0	6 6	20	72	14	140	65	6	3 $\frac{3}{4}$	50

The above mills are of the type arranged with a series of sieves on the circumference, and may be installed for dry grinding practically all classes of material such as limestone, basic slag, coke, quartz, marble, glass, fire-clay, coal, bones, charcoal, etc.

They are largely used on cement works as a preliminary grinding mill for cement clinker, and with modifications may be adopted as a preliminary mill for wet grinding.

"Steel Ball" Tube Mills (Preliminary Mill Dry Grinding)

Size of Mill.			Driving Pulleys.			Weight of Steel Balls.	Output per hour.		B.H.P.
							Rotary Clinker.	76×76 mesh.	
Diam. ft. in.	Length. ft. in.	R.P.M.	Diam. in.	Width. in.	R.P.M.	tons.	tons.		
4 0	11 0	32	78	12	175	5	3	50	
4 6	13 0	28	84	14	150	10	5	100	
5 6	15 0	26	96	15	125	15	7	130	

"Flint Pebble" Tube Mills (Finishing Mill Dry Grinding)

Size of Mill.			Driving Pulleys.			Weight of Flint Pebbles.	Output per hour.		B.H.P.
							Rotary Clinker.	180×180 mesh.	
Diam. ft. in.	Length. ft. in.	R.P.M.	Diam. in.	Width. in.	R.P.M.	tons.	tons.		
3 0	12 0	32	48	8	190	2	1	20	
4 0	16 0	31	48	10	190	3 $\frac{1}{2}$	1 $\frac{1}{2}$	30	
4 6	18 0	28	54	12	175	4 $\frac{1}{2}$	2	35	
5 0	20 0	27	60	14	175	5 $\frac{1}{2}$	3	50	
5 0	22 0	28	72	12	175	6 $\frac{1}{2}$	4	70	
5 6	20 0	25	78	14	160	6 $\frac{1}{2}$	4	70	
5 6	22 0	28	84	14	150	8	4 $\frac{1}{2}$	90	
6 0	26 0	28	90	16	150	12	8	120	
6 0	30 0	25	96	16	150	16	10	150	

Note.—When grinding cement clinker produced by the chamber kiln process the output of both the above types of grinding mills may, owing to the softer nature of this clinker, be increased approximately 50 per cent.

Belt Conveyors

Width of Conveyor Belt.	Conveyor Drums			Ratio of Gearing.	Driving Pulleys.			Output per hour.	B.H.P.
	Diam. in.	Width. in.	R.P.M.		Diam. in.	Width. in.	R.P.M.		
12	24	14	40	4 : 1	24	3	160	10	2
16	24	18	40	4 : 1	24	3	160	25	3
20	30	22	30	4 : 1	30	4½	120	40	4
24	30	26	30	4 : 1	30	4½	120	55	5
30	36	33	26	4 : 1	36	6	104	90	7½
36	45	39	20	6 : 1	45	7½	120	140	12
42	45	45	20	6 : 1	45	7½	120	160	15

The above conveyors are of the type fitted with troughing rolls and flat return idlers. The outputs are based on a belt speed of 240 feet per minute when dealing with material such as limestone, crushed to 2½ in. cube, or similar material weighing about 1 cwt. per cubic foot.

The angle of inclination should not exceed 22° under favourable circumstances, and where possible it is advisable not to exceed 15° to obtain the best results.

Screw Conveyors

Screw.		Driving Pulley.			Output per hour. Cement.	B.H.P.
Diam. inches.	R.P.M.	Diam. inches.	Width. inches.	R.P.M.		
6	90	18	4	90	2½	½
8	70	24	4	70	5	1
10	60	30	4	60	8	1½
12	50	36	6	50	10	2
14	40	48	6	40	15	3
16	30	60	6	30	20	4
18	30	60	8	20	25	5

The above figures are for conveyors not exceeding 50 feet in length, driven direct without the introduction of gearings. Where longer lengths are employed it is advisable that the final drive should be through reduction gearings.

B.H.P. to drive conveyors: Length in feet × output per hour in tons × .004.

Bucket Elevators with Gearing
(up to 50 ft. centres of drums)

Width of Buckets.	Top and Bottom Drums.			Ratio of Gearing.	Driving Pulley.			Bucket Speed ft. per minute.	Output per hour.	Approx.
	Diam. in.	Width. in.	R.P.M.		Diam. in.	Width. in.	R.P.M.			
4	18	6	40	4 : 1	18	3	160	188	2	1½
5	18	7	40	4 : 1	1	3	160	188	3	2
6	24	9	30	5 : 1	24	4	150	198	4	2
8	24	11	30	5 : 1	24	4	150	198	6	2½
10	36	14	20	6 : 1	30	5	120	188	8	3
12	36	16	20	6 : 1	30	5	120	188	12	4
14	42	18	18	6 : 1	36	5	108	196	15	4
16	42	20	18	6 : 1	36	5	108	196	21	5

The above outputs per hour are based on the assumption of the buckets being only 40 per cent full.

The above figures are based on handling fine material, such as ground coal, rotary clinker, cement, etc., and the bucket speeds given are suitable for these materials. Top and bottom drums should always be made as large as practicable to reduce risk of bucket fasteners pulling through and belts cracking across a line through the fasteners, which will happen, due to continual bending, where small diameter pulleys are employed. Belts must be selected with due regard to conditions of working and where the material to be handled is at all hot; balata or solutioned belts should not be employed. In these cases solid woven belts, asbestos treated and having strengthened edges, should be adopted.

Bucket belts should always be wider than the buckets (in large sizes at least 2 in. wider), so as to keep the holes for the bucket belts as far as possible from the edges of the belt.

The top and bottom drums should also be from 1 in. to 2 in. wider than the belt, and well "crowned" to ensure the belt does not work to one side, due to oscillation which may take place.

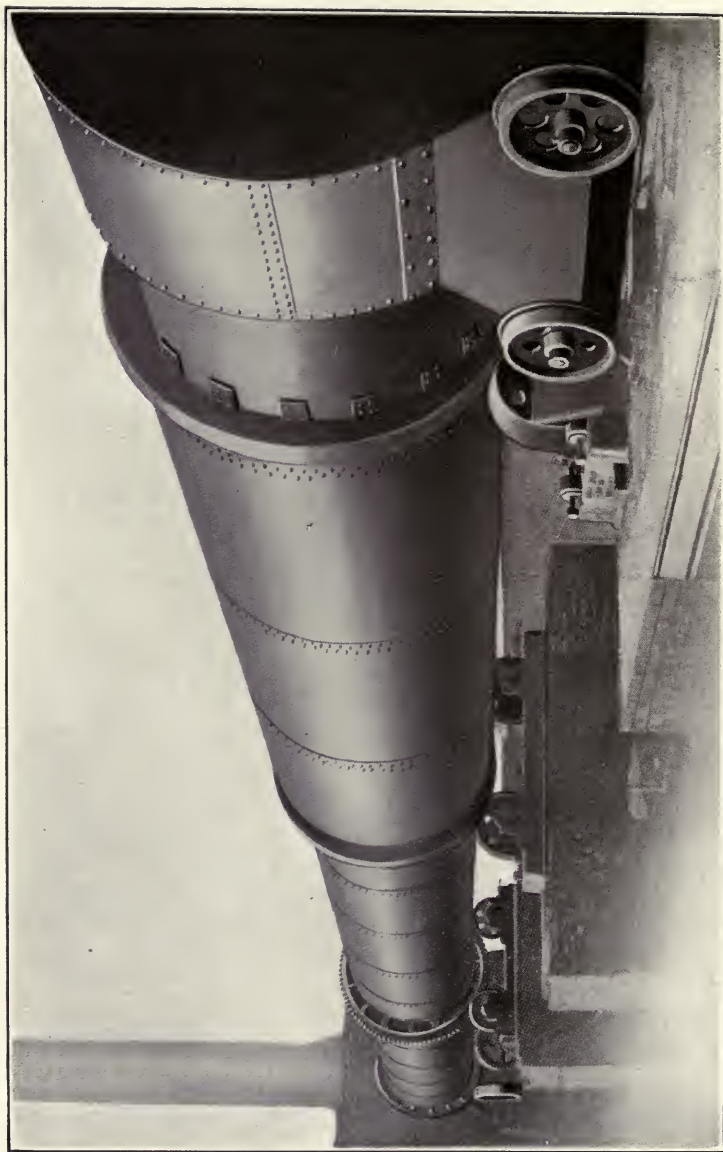

EDGAR ALLEN'S ROTARY KILN.

[To face page 30.]

CHAPTER VI

THE ROTARY KILN

PROBABLY no other industry has developed so rapidly in the whole world generally, and the United States particularly, as the Portland Cement industry; and this development is undoubtedly due to the rotary kiln. Not only has the quality of the product been raised, but the cost of manufacture has correspondingly decreased, and with these factors at work the industry was bound to grow by leaps and bounds.

The following figures will show the output of cement in the United States for various years before and after the establishment of the rotary kiln as a successful machine :—

Year.	U.S.A. Output in Barrels.	Remarks.
1889	250,000	80 per cent burned with the ordinary kiln.
1890	335,000	" " " "
1896	1,543,000	This year saw the success of the rotary kiln firmly established. Oil fuel used.
1900	8,500,000	Pulverized coal was used as fuel, 90 per cent burned in rotary kiln.
1911	80,000,000	Practically all burnt in the rotary kiln. Fuel, pulverized coal and crude oil.
1912	88,000,000	
1913	92,097,131	
1914	88,230,170	

These figures definitely show that the development of the industry has been contemporaneous with and, we may assume, due to that of the rotary kiln.

Originally of English conception and design, it remained for American cement engineers to modify, improve, and afterwards utilize the rotary kiln for burning Portland Cement, and to-day the United States of America burns practically all her cement in this way, Germany 70 per cent, and Britain, the home of the kiln, about 60 per cent.

The idea of a rotating furnace was first conceived by Crampton as far back as 1877, but no practical application was made till Ransome patented his design in England in 1885.

That gentleman's ideas were certainly very modest in view of recent developments, for the largest Ransome kiln ever built measured only 26 feet long and 5 feet in diameter. Truly great things had but small beginnings.

He fired his kiln with "producer gas", but no success attended his efforts, for he experienced great difficulties with the lining, a very vexed question with many manufacturers even to-day.

Still, he set others thinking on the subject, and the next development took place in the United States, at East Kingston, New York State. Here Mr. D. Navarro, after experimenting for some time, organized a cement company, called the "Keystone Cement Company", and located in the Lehigh Valley. A plant was erected, and a rotary kiln installed of dimensions 40 feet in length and 6 feet in diameter.

Much experimental work was undertaken, and with varying success for a period of two years. At the end of this time the Keystone Cement Company was reorganized under the name of the "Atlas Portland Cement Company", and they are to-day the largest cement producers in the world.

Mr. H. J. Seaman was appointed general superintendent, and Mr. Hurry, an Englishman, the engineer in charge of the plant. By united efforts, these gentlemen carried on an extended series of experiments lasting several years. During the early part of the period they used petroleum as fuel, but this proving prohibitive from the point of view of cost they turned their attention to pulverized coal, which proved to be much less expensive on account of the low cost of bituminous coal as compared with the oil. This form of fuel is now generally adopted.

After a few years of successful working, the Atlas Co. constructed another plant in the Lehigh Valley, and installed fourteen rotary kilns; and from this time onward the use of the furnace has advanced with marvellous rapidity.

A year or two after the erection of the second Atlas Factory, that genius, the world's greatest inventor, Thomas A. Edison, embarked in the cement industry. With such a man interested enormous developments were bound to follow, and they did in a way the pioneers never dreamed.

Hitherto the largest kilns had been 60 feet long and 6 feet in diameter; the results Edison attained in his New York City plant were marvellous.

The Edison kiln was 150 feet long and reported to yield from 340 to 370 barrels of cement daily, with a fuel consumption of 85 lb. of coal per barrel. The old 60 ft. kilns usually gave from 160 barrels to 180 barrels daily when working on a dry limestone-clay mixture, using 120 lb. to 160 lb. of coal per barrel.

Such a striking contrast was too remarkable to admit of any delay. Instantly all owners of rotary kilns began to consider the possibility of lengthening their kilns.

Success being demonstrated with these enlarged kilns, their adoption is now universal.

Yet the development of the rotary kiln has by no means reached the limit of perfection. Quite recently kilns have been

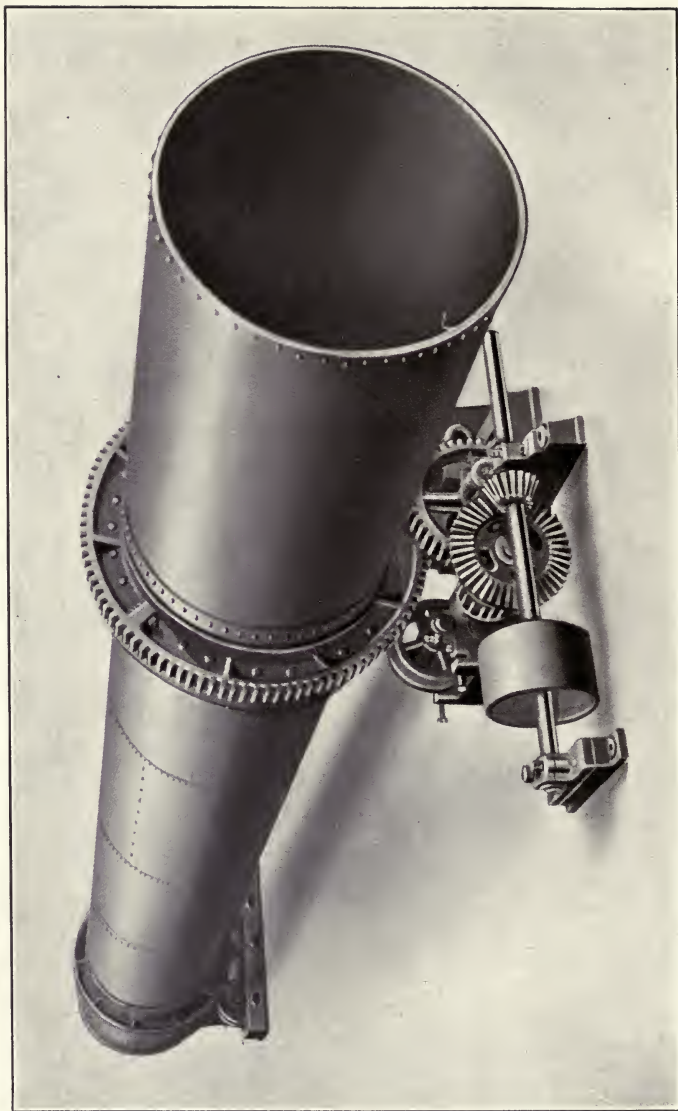

EDGAR ALLEN'S ROTARY CLINKER COOLER.

constructed in the United States 250 feet long and 12 feet in diameter, but although the output has been very large, great trouble has been experienced with the lining, probably on account of so large an arch being subjected to such high temperatures.

Several kilns are now successfully running in England, of lengths varying from 200 feet to 230 feet by 9 feet diameter, in connection with the wet process and producing from 170 to 190 tons of cement clinker in each twenty-four hours. They have a coal consumption of from 26 to 30 per cent with slurry containing from 40 to 42 per cent of water.

As originally designed the rotary kiln was a plain cylinder, and the majority of those running to-day are of the same construction. A modification of this type has, however, been recently introduced with an enlarged firing zone. It is asserted that by this device the output of the kiln is increased and the coal consumption lessened. These are debatable points, but one advantage is already proved. You can carry a very thick coating with a reduced tendency to "ring up", because you can burn out your ring without fear of burning out your lining.

The clinker cooling cylinders are placed under the kilns in Europe. The clinker itself, leaving the kiln at a temperature of about 2,000° F., falls into another rotating cylinder, which is so arranged that the air for combustion passes up through the cooler into the kiln. Now, the clinker, when taken from the cooler, has a temperature of only 150° to 200° F., so that nearly the whole of the sensible heat has been extracted by the air and returned to the firing zone.

One thing, however, is of vital importance. The continuous running of the kiln is essential, and especially so now that they have reached such huge dimensions. Cessation of work for one hour only, means a very great loss to the manufacturer.

CONSTRUCTION

The kiln, after all, is but a plain cylindrical tube, *but it is absolutely imperative that only the best materials and workmanship should be used in its construction.* The shell, where the roller bearing rings and girth gear are secured, must be heavily reinforced by additional plating to ensure stability under the heavy stress. Rollers, bearings, shafts, and driving mechanism must be strong and perfectly fitted. In a word, design, materials, and workmanship must be of the highest standards of excellence if economy and low maintenance are to be secured.

The kiln is supported by four or five sets of heavy roller bearings according to the length of the kiln, the usual pitch being from 30 to 35 feet, and the kiln is driven by a train of gear wheels, machine-cut except as to the girth gear and pinion.

Speed is controlled by regulators, from 1 to $2\frac{1}{2}$ revolutions per minute, to suit the condition of the burning material.

The standard inclination is one in twenty-five, so that material fed into one end will move by gravity to the other.

Large dust chambers constructed of brick are provided, into which the end of the kiln projects. It is a good practice to have a hanging brick curtain wall in the centre of these dust chambers, which tends to retard the current of heated gases, and thus deposits most of the fine dust, which otherwise would be lost through the chimney which is situated immediately beyond.

Each kiln should have a separate chimney if possible, and be lined with fire-brick 60 to 80 feet up, with an air-space between the chimney wall and lining.

The lower end of the kiln projects in a movable hood, the bottom of which covers the rectangular hole in the floor leading from the cooler and conveying hot air direct from the cooler to the kiln. The powdered coal from the coal-feed pipe carries with it a certain quantity of air, also a certain quantity from around the hood, and thus supports combustion. The front protects the burner and reduces to a minimum the admission of cold air to the kiln.

Above the firing floor, at least 15 feet from end of kiln in a horizontal line, is fixed a large steel bin (lined with concrete) for supplying the kiln with fuel (capacity for at least twelve hours).

This coal-dust is fed through a double-flight screw conveyor from the storage bin to a blow-pipe, where it meets a current of air supplied by a sirocco fan.

The amount of both coal and air can be regulated by means of speeders by the burner in charge.

The coal-feed pipe extends through the hood (which closes the end of the kiln) and inside the kiln about 6 inches; through the pipe is blown all of the fuel which supplies the heat necessary to burn the mixture.

When starting a kiln, a few old cement bags soaked in paraffin are secured on the long steel clinker shovel and ignited and placed near the coal-feed pipe; a current of coal-dust is turned on and ignited. In half an hour the kiln is hot enough to cause spontaneous combustion, and an intense heat of 2,800 to 3,000 degrees F. is maintained in the kiln.

This intense flame is projected on the raw material. As the raw material travels down the kiln chemical changes, brought about by the terrific heat, take place, viz. :—

- (1) Evaporation of the water in the mixture.
- (2) Dissociation of combined water and loss of organic matter in the clay.

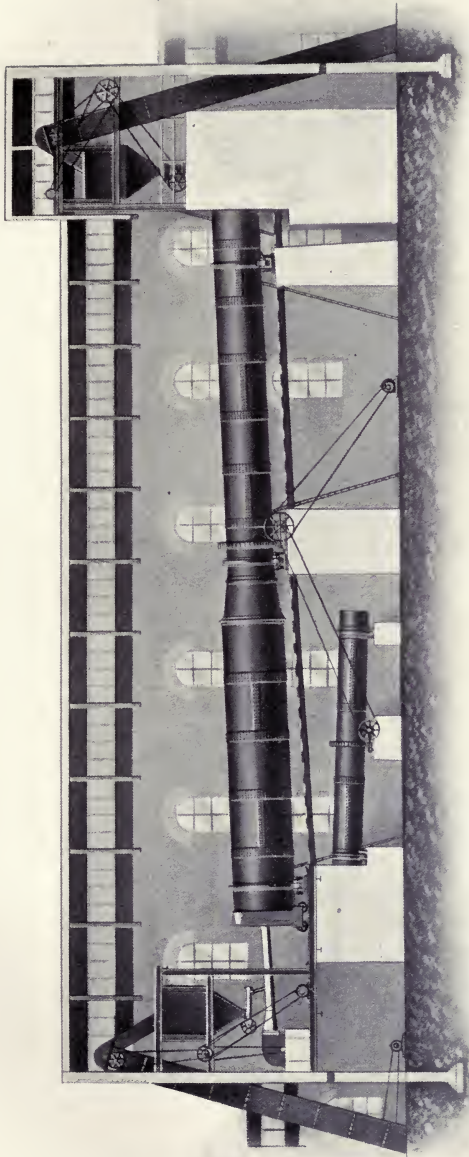

JOHNSON'S ROTARY KILN AND COOLER.

[To face page 42.]

- (3) Dissociation of sulphates and alkalies.
- (4) Dissociation of carbonates.
- (5) Chemical combination (incipient fusion) of silica, alumina, and lime in the hot zone of the kiln.

LININGS FOR ROTARY KILNS

The lining of the rotary kiln is of the utmost importance, and great care should not only be exercised in selecting the class of brick, but to see that it is well fitted in the kiln in order that success may be achieved.

Fortunately, our British manufacturers are closely studying the question, and are now producing an excellent fire-brick equal to any that can be obtained abroad; they are tackling the proposition in a scientific way, and continued improvements may be expected. But it must be borne in mind that all lining failures are not to be attributed to the bricks themselves. It may be due to lack of care in constructing and laying in the work. The bricks should be made to fit the radius of the kiln, and put in dry without fire-clay or cement. The last brick in the circle, being the key to the whole ring, should be well driven. The whole ring should be afterwards grouted up with neat cement, the greatest care being taken to fill up all the interstices.

But even if the bricks are perfectly fitted to the kiln and of the best composition and suitable for the material to be burnt, *if the rotary kiln has not been well designed to ensure absolute stability, especially at the roller bearing rings and girth gear, trouble will be always experienced at these positions with the lining.* The shell should also be of sufficient thickness to prevent torsion, which also reduces the life of the lining.

Spalling (which is a popping-off of large pieces of the brick) occurs owing to the face of the bricks, becoming vitrified by the intense heat, being absorbed faster than they can conduct it to a cooler zone, and the elasticity of that portion is lost, and further heating or cooling taking place or movement in a kiln structurally weak, the vitrified section drops off, which otherwise would have been held by compression of the bricks themselves in a rigid kiln.

Assuming you have a strongly constructed kiln, lining blocks of correct composition and well fitted, and the question of fuel considered, there is no reason why a run of six months should not be obtained even where a highly siliceous material is being burnt, and even nine months with aluminous material, whilst in the upper portions of the kiln it should, with slight repairs, render efficient service for years.

Most of the fire-bricks manufactured in Great Britain are of an acid character and high in silica, as the following analysis will show:—

I.		II.	
Combined silica	80.76	Silica	26.24
Alumina	11.83	Alumina	12.46
Oxide of iron	2.10	Ferric oxide	1.06
Carbonate of lime	1.00	Lime	<i>nil</i>
Carbonate of magnesia . .	1.26	Magnesia	<i>nil</i>
Alkalies, etc.	<i>nil</i>	Sulphuric anhydride . .	<i>nil</i>
Water and organic matter .	2.69		
	<hr style="width: 100%; border: 0.5px solid black; margin-top: 5px; margin-bottom: 5px;"/> 99.64		<hr style="width: 100%; border: 0.5px solid black; margin-top: 5px; margin-bottom: 5px;"/> 99.76

In the United States the high alumina one is the standard, and having a composition within the limits of the following table :—

Constituent.	Maximum Percentage.	Minimum Percentage.
Silica	55.0	50.0
Alumina	47.0	40.5
Ferric oxide	3.0	2.0
Lime	1.0	n.d.
Magnesia	1.0	n.d.

The operation of burning the clinker is a skilled process, and none but a capable and experienced hand should be employed as a burner. He must know exactly how the clinker should be burnt, and possess a keen eye for "heat", to enable him to know when the kilns are hot enough to properly clinker the raw material.

Coating a freshly lined kiln, and patching also, need a skill which is only acquired by much practice, and should in no circumstances be entrusted to a mere novice.

Though the rotary kiln has now firmly established itself as the most economical and efficient form of mechanism for the production of Portland Cement, many of the old stationary kilns, both of the intermittent and continuous varieties, are still in constant use in Europe ; nor is their product in any way inferior to that produced by the modern method. But to ensure this good clinker and reduce the quantity of under-burned material, the lumps of dry slip must be reduced to a uniform size of from 90 cubic inches to 100 cubic inches, and the coke must be no larger than a hen's egg. Kilns charged with dry slip and coke of irregular sizes cool very slowly and remain for a longer period in the incandescent state, and the result is the clinker spontaneously crumbles to dust.

But increased competition in the cement trade is causing the manufacturer to put forth every endeavour to reduce the cost of production, and although at present many proprietors do not see their way to modernize their plants by the adoption of the rotary system, yet the day is not far distant when the stationary kiln, be it intermittent or continuous, will give place to the rotary kiln.

For the rotary kiln process not only produces a more regularly



INTERMITTENT KILN ERECTED BY WILLIAM ASPDIN
AT NORTHFLEET, KENT.

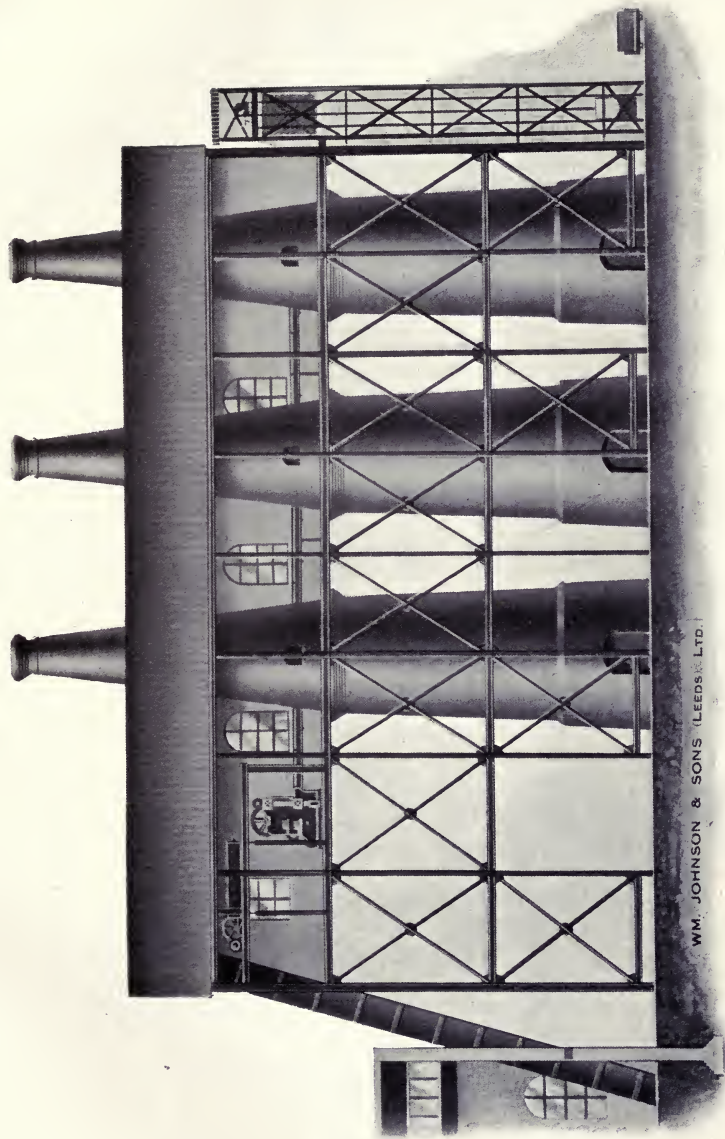

WM. JOHNSON & SONS (LEEDS) LTD.

BATTERY OF CONTINUOUS SHAFT KILNS.



NEWELL'S DOUBLE-TUBE COAL DRYER.

[To face page 44.

burnt clinker, but it is unquestionably more economical than the stationary kiln, having, as it does, the following advantages:—

- (1) A continuous running.
- (2) An automatically regulated flow of raw materials to the kiln.
- (3) Control of raw materials in their passage through the kiln. This is regulated by the revolution of the kiln, which may vary from one revolution in $2\frac{1}{2}$ minutes to one revolution in fifty or sixty seconds.
- (4) Complete control of calcination.
- (5) Reduced labour costs.
- (6) A more uniform clinker with greater cementitious properties.

ROTARY KILN FUEL

COAL, ITS STORAGE, DRYING, AND GRINDING

The fuel used in rotary kiln practice is pulverized coal, crude oil, natural gas, and producer gas.

Coal

Coal must be of the bituminous class, its suitability being governed by the percentage of ash it contains for the raw materials to be calcined to prevent clinkering rings forming immediately beyond the clinkering zone. The more siliceous the raw material the higher may be the percentage of ash, but with aluminous materials the ash should be kept low.

Average Analysis of Bituminous Coal

Volatile matter	35 per cent
Fixed carbon	53 ,,
Ash	8 ,,

Anthracite coals are high in fixed carbon and low in volatile matter; although giving high temperatures will not burn well in the rotary kiln, being slow to ignite, but may be mixed with success with the bituminous class as high as 30 per cent or even more, but great care must be taken that the two classes of coal are thoroughly mixed and finely pulverized; if by the use of anthracite the coating from the kiln lining is removed, or the fire-bricks themselves are reduced rapidly by the abrasive action of the flame, the percentage of anthracite must be reduced.

Storage

Coal, if possible, should be stored under cover, and for an output of 3,000 tons of cement weekly storage capacity should be provided for three weeks' supply, say 3,000 tons, but storage will be controlled by local conditions of delivery. Coal can be economically handled by locomotive crane and grab.

Crushing

Provision should be made for crushing the coal before drying, as it is not always possible to get the slack, and run-of-mine coal will have to be dealt with.

Grinding

Coal is a difficult material to pulverize finely. The mills are generally similar to those used in grinding the raw materials or cement clinker ball and tube, Griffin, Fuller-Lehigh, etc. Capacities of these mills are given in the description.

As the drying and grinding of coal is attended with a certain amount of danger from fire and explosion, these operations should be performed in buildings detached from the remainder of the plant. Ample ventilation and extensive head-room should be provided. No coal-dust must be allowed to collect, nor should naked lights be permitted at any time near the mill.

Nor is the only risk attendant on the use of coal. There is always the possibility that heaps of coal may generate heat and take fire.

THE AERO PULVERIZER

The Aero Pulverizer is a complete equipment for supplying pulverized coal to rotary kilns, rotary dryers, boilers, furnaces, etc., making practicable the highest efficiency obtainable from burning coal. It makes coal burn like a gas, with a flame, the physical and chemical character of which is regulable—a flame that may be elongated or shortened, thus placing the zone of highest temperature where needed—a flame that may be made oxidizing, reducing or neutral, as occasion may require.

The coal is burned as pulverized, and there is no storage of the powder with its attendant hazard. Artificial drying before pulverizing is not necessary if the coal supply be sheltered from rain and snow. Where the Aero is used it is wholly a furnace question whether a dryer should be installed; it is not at all a pulverizing or storage question.

Labour is reduced to a minimum.

Slack coal at low cost yields its last B.T.U.

The Aero Pulverizer approaches the subject of coal-burning from the theoretical side, and therefore pulverizes the coal to an impalpable powder, and surrounds each of its minute particles with the amount of air which will furnish just the required oxygen. The fineness of the pulverization may be regulated by attention to the dampers which control the movement axially of the air within the machine. If that movement is slow the centrifugal force keeps all the coarse particles at the periphery, but if the movement axially is rapid it in part overcomes centrifugal force and draws through the machine a coarser grade of

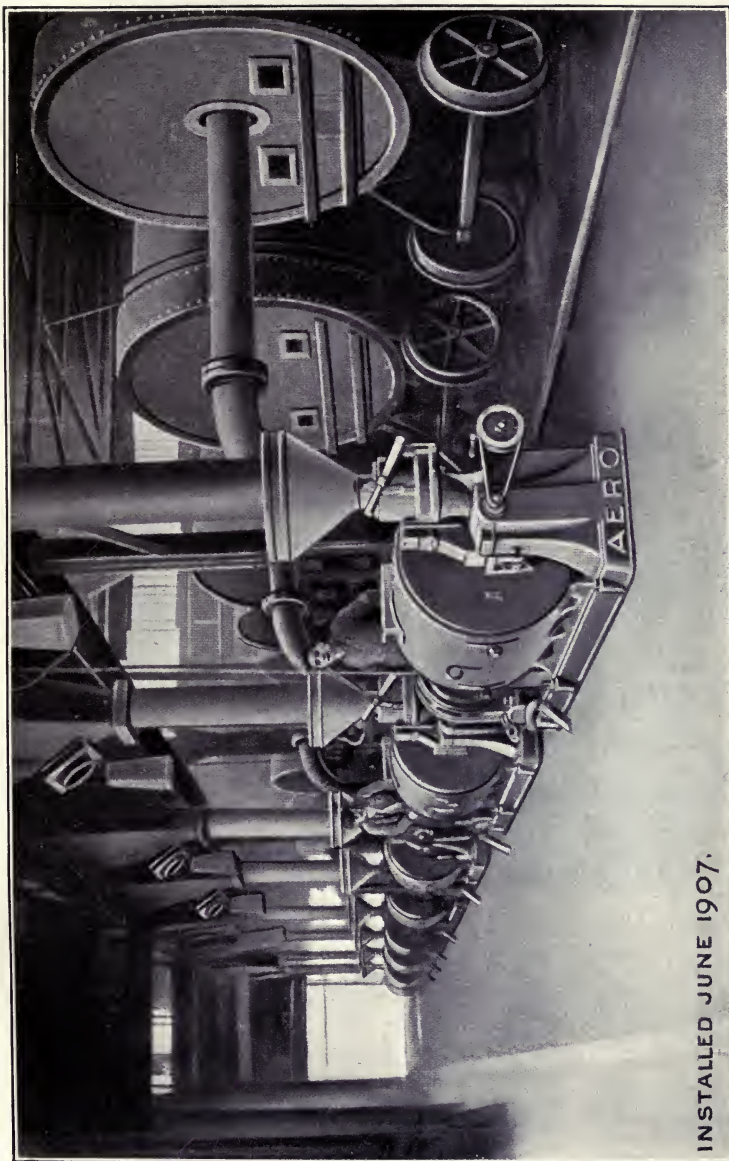

INSTALLED JUNE 1907.

A BATTERY OF ROTARY KILNS EQUIPPED WITH AERO PULVERIZERS.

[To face page 46.]

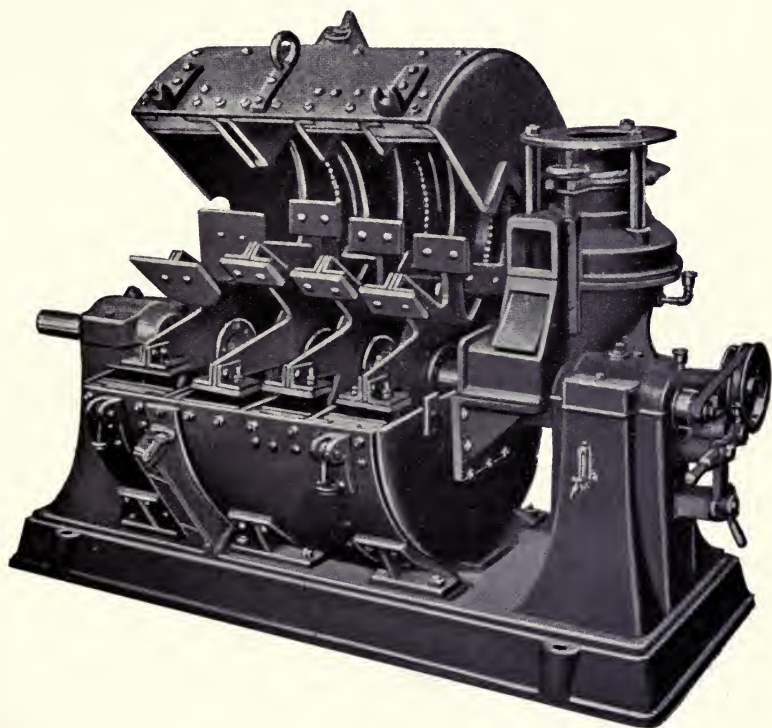

AERO PULVERIZER.

material. Powdered coal and air in regulable proportions are intimately mixed in the pulverizer, and the mixture reaches the furnace instantly it reaches the pulverizer. Thus the Aero system is emancipated from not only the dryer, but the powdered coal conveyor apparatus, the storage bin, the mixing chamber, and the feeding apparatus with the power units required for the several operations, which are incident to all central station pulverizing systems. There is no smoke, no carbon in the ash, no CO in the flue gases, and only a trace of O₂; no appreciable excess air is admitted to reduce the temperature of the products of combustion. There is no opening of doors, no intermittent firing, no banked fires, no delay in meeting a sudden overload.

The efficiency of heat from combustion is directly as the rapidity of combustion. The decaying log is a form of combustion so slow that its efficiency is not noticeable. The greatest efficiency and rapidity is obtained by bringing each atom of carbon in contact with two atoms of oxygen, and no more, under conditions permitting chemical union, and the conditions produced by the Aero measurably approach the theoretical in this respect.

The Aero Pulverizer consists of four interiorly communicating chambers of successively increasing diameters, in which revolve paddles on arms of correspondingly increasing lengths. The separate chambers are in fact separate pulverizers on a single shaft, each succeeding pulverizer having greater speed at its periphery and therefore greater power for fine grinding. An additional chamber contains a fan, the function of which is to draw the more finely pulverized material successively from one chamber to the next, and, finally, to deliver it through the pipe connexion to the furnace under the impetus of a forced draft. The separate pulverizers and fan are enclosed in one steel cylinder. A regulable feed mechanism accurately controls and varies the quantity of coal admitted to and delivered by the machine. The feed mechanism is exact and uniform in its operation, and is easily adjusted to meet even minute variations in the fuel requirement. Two regulable inlets in the feed mechanism admit the air required for fine grinding. An auxiliary inlet between the last work chamber and the fan, controlled by a damper, admits such additional air as it required for combustion. The air dampers with the feed give perfect regulation of the flame within a wide range.

CRUDE OIL

Crude oil is an excellent fuel, and the only consideration which would rule it out is its cost. Should that prove satisfactory, then, from all points of view, it is preferable.

It can be transported with much greater facility than any other fuel.

No coal-drying, grinding, or conveying machinery are required.

The rotary kiln can receive its supply of fuel in a minimum of time by the mere turning of a valve. The ease with which the supply can be regulated is another important factor in its favour.

But these facts are subservient to the question of the economy of the fuel itself.

Given ordinary conditions, four barrels of oil would do the work of 1 ton of coal.

These four barrels of 15° oil would weigh 1,348 lb., and the total heating value at 18,360 B.T.U. per lb. would be 24,739,280 B.T.U. On the other hand, 1 ton (2,240 lb.) of coal at 12,600 B.T.U. per lb. would have the heating value 28,224,000 B.T.U.

Thus the four barrels of oil with a smaller heating value will do the same amount of work as the ton of coal with a much larger heat value, due to the fact that with the oil fuel we have a much more perfect combustion.

NATURAL GAS

Natural gas where obtainable is of course the cheapest form of fuel, but at present it is found in few localities, the State of Kansas, U.S.A., being the only one known to the author.

PRODUCER GAS

Where producer gas has been tried in the Western States it has been found successful, and with the development of the producer a more extended use for firing the rotary kiln may be expected.

COOLING, STORING, AND GRINDING THE CLINKER

The cement clinker leaves the kiln at a temperature of about 2,000° F., and the method of cooling it now generally adopted in modern practice is a rotating cylinder situated immediately under the kiln, and so arranged that most of the air required for combustion in the kiln must pass through the cooler; lifting plates are provided and placed longitudinally around the internal periphery, and these lift the clinker and let it fall in showers through the current of cold air in its passage to the kiln. It is a very effective method of cooling the clinker; a large percentage of the heat is recovered and returned to the kiln.

The clinker leaves the cooler at a temperature varying from 150° to 200° F.

Storing the Clinker

The clinker at the above temperature can readily be conveyed to the clinker store, which must in all cases be provided and roofed over, or great trouble will be experienced not only with the

setting time of the cement but with grinding mills with wet clinker.

Storing the clinker for a week or so with a small percentage of water added, say 1 per cent, as the clinker is leaving the cooler, gradually combines chemically with the constituents of the clinker, reducing the quick initial setting of the cement, and is certainly more easily pulverized if so treated.

The cement mill is run for $5\frac{1}{2}$ days in the week, and storage accommodation is therefore necessary for the clinker, as the kilns are run continuously unless under repair.

Grinding the Clinker

The machinery and power required for grinding the clinker are very closely the same as that required for grinding the hard raw materials for the same output. This will at first appear improbable, the clinker being much harder to pulverize, but it must be considered as mentioned under grinding, that for every ton of cement clinker 1.6 tons of raw materials are required, so with the several types of grinding machinery the one giving the best finished product with low cost of repairs and less power consumption will appeal to the manufacturer.

DUST COLLECTORS

For removing and collecting dust from the rotary kiln firing floor, coal-drying, coal and clinker grinding buildings, it is necessary to install a dust-collector plant. Essentially the Sturtevant system consists in collecting the light dust, which would ordinarily be wasted, by currents of air at the various points on the machines comprising the grinding plant where the dust is produced and conveying it to a central "collector".

For this purpose the machines are fitted with suitable hoods and connected to a piping system, which is itself coupled to the fan producing the air. The dust-laden air is discharged by the fan into a suitable dust collector from which the purified air escapes, whilst the dust is automatically shaken down into a worm conveyor, which delivers it to the grit hopper of the tube mill, so that the whole of it is recovered, and in passing through the tube mill is intimately mixed with the remainder of the finished cement.

It is obvious that in addition to the market value of the dust recovered in this manner there are other advantages and economies obtained in the operation and upkeep of the grinding plant, directly due to the installation of a dust-collecting plant.

For instance, as all the machines work under a slight air suction, the disadvantage sometimes experienced in connexion with dust entering bearings and working parts is entirely eliminated, and, further, the passage of air through the machines,

due to the fan suction, has a cooling effect on the working parts, and at the same time immediately carries off any excess moisture present in the material being ground. Any openings or clearances in the machines, which ordinarily would allow dust to escape, are actually utilized as air inlets, and incidentally this sets up ventilation in the mill room, improving the working conditions of operators.

An illustration of the Sturtevant "Steel Plate" Dust-collecting Fan appears on opposite page. It has been designed especially for the class of work referred to and is supplied in eighteen sizes, each being made to discharge the air horizontally or vertically in either direction, as may be desired, and in addition, with the driving pulley, either on the right or left hand. Hence, a suitable fan can be selected to fit any particular set of conditions.

Two different types of collectors are shown on subsequent pages. The first is known as the Sturtevant Patent Air Filter and the second as the Sturtevant Patent Dust Collector.

The Air Filter is exceptionally efficient and simple in operation. There are very few moving parts, and when running the mechanism requires practically no attention. It is constructed on an expanding unit principle, compensating for extensions to plant.

The Dust Collector is of the "Cyclone" type, and is generally used where the dust made is comparatively heavy.

These Dust Collectors are made in many different sizes to suit the volumes of air handled by the Dust-Collecting System, of which they form a part.

The particular advantage of this patented device over the ordinary type is that owing to its peculiar internal construction the "back pressure", against which the fan has to deliver the dust-laden air, is reduced to a minimum, thus affecting an important saving in the power absorbed by the Dust-Collecting System.

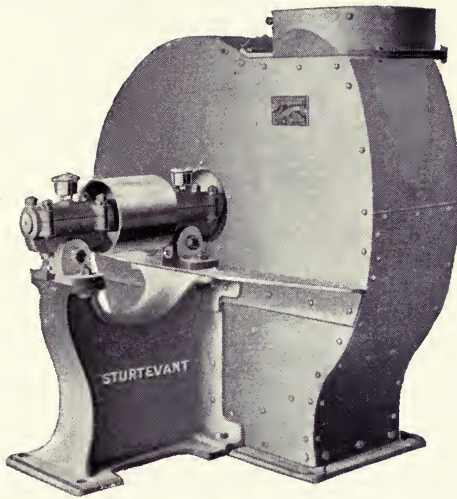

“STEEL PLATE” DUST-COLLECTING FAN.



DUST COLLECTOR.

[To face page 50.]

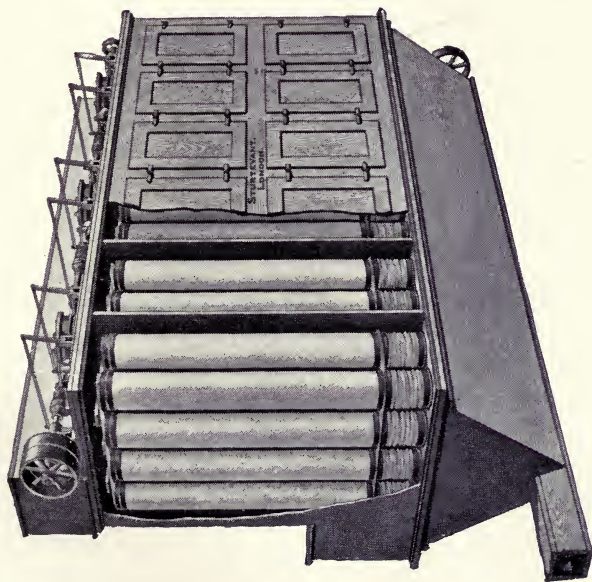

A SIX-SECTION AIR FILTER.

CHAPTER VII

POWER PLANTS

THE process of manufacture in a modern cement factory is such as to demand a continuous supply of power at all times.

In the older established factories day and night operation was the rule rather than the exception, these works closing down only at week-ends, and whilst it was not desirable to close down oftener than possible, the effect of a stoppage of any portion of the works was not so serious as on a modern plant equipped with rotary kilns, it being essential, in order to obtain the best results in production and economy, that this type of kiln, together with its auxiliary machinery, should run day and night for long periods without any stop, except those of a few moments duration occasionally required to correct the burning of the clinker, or to patch a weak spot in the lining; and provided the constructional details of the kiln are correct, the length of time that a rotary kiln can run without a stop is governed by the length of life of the fire-brick lining, and instances of 26 weeks and 32 weeks on kilns 180 feet and 200 feet long are met with in practice.

The selection of the power plant is therefore a matter which must receive the most careful consideration, and it may be taken as an axiom that the success of the concern will be dependent in a large measure upon the judgment used when deciding this important part of the works.

From the foregoing remarks it will be realized that the outstanding features must be—

- (1) Capacity for continuous running for long periods.
- (2) Economy.

The type of motive-power adopted will also depend upon a number of other considerations, amongst which may be mentioned—

- (3) The size and output of the works.
- (4) The type of transmission, whether electrical or through shafting, etc.
- (5) Quantity and quality of water supply.
- (6) Ability to carry overload and take care of large fluctuations of load.
- (7) First cost.

A large amount of experience must be brought to bear in the final selection of the prime mover; the problem must also be

approached from an engineering as well as manufacturing point of view, and if those in authority do not possess this knowledge, then it were wise to obtain the services of an engineer experienced in this branch of industry, as the type selected will determine the whole design of the power plant, and when once installed it must be there to give years of unfailing service, at the same time maintaining its initial efficiency.

As in other industries where a fairly large amount of power is required, the choice is practically limited to one of the following, each of which is represented by many various designs :—

- (1) Electrical power purchased from supply station.
- (2) Gas-engines with gas-producing plants.
- (3) Reciprocating steam-engines.
- (4) Steam turbines.

All the foregoing types are to be found in the cement industry, and as far as British works are concerned the reciprocating steam-engine at present occupies the premier position, due in a great measure to its simplicity and reliability, coupled with the fact that it was first in the field. Gas-engines also occupy a fairly prominent position; they are rarely found in sizes over 400 b.h.p., and where employed have proved economical and reliable; they do not possess the same capacity as a steam-engine for carrying overload, but in cases where water supply is limited, or where fuel is costly, they would have a very big argument in their favour.

Steam turbines, though well established in other industries, and particularly electric lighting stations, are comparatively newcomers on cement works, and in the few instances where they have been installed they are entirely successful.

After deciding upon the site for the works it will be necessary to carefully consider the class of raw material from which the cement is to be made, as this item has an important bearing on the amount of power required in the initial stages of manufacture, which may be considered as being up to and including the actual production of the slurry.

In order to illustrate this point it may be stated that where raw materials of a soft nature, such as chalk and clay, are used, as found in the southern portions of England, the machinery employed to produce an intimate mixture of these materials and the resultant slurry almost invariably consists of a series of wash-mills, usually four in number, about 16 feet internal diameter, driven by a common shaft placed above and running along the longitudinal centre line of the mills.

Such an arrangement does not require more than 120 b.h.p. to drive it when starting up in a clean condition, and after running for such a length of time that it becomes necessary to close down in order to clean out the loose flints and pebbles,

it would be found that the power taken at the finish was about 330 b.h.p. ; the average power throughout such a run would be 250 b.h.p. These figures relate to mills of large output under the best conditions as regards regularity of feed, working day and night with usual stoppages for meal-times, and the amount of raw material dealt with by a set of mills requiring this amount of power would be in the neighbourhood of 60 tons of chalk, together with the necessary amount of clay, and would produce sufficient slurry to manufacture, say, 36 tons of Portland Cement with an average expenditure of 7 b.h.p. hours per ton of cement.

On the other hand, where the raw material consists of a hard substance, such as limestone rock, the methods and machinery employed are somewhat different ; it becomes necessary in the first place to install crushing machinery capable of dealing with the largest block that would be quarried and reducing it down to anything between $2\frac{1}{2}$ in. and 1 in. cube preparatory to feeding in into the grinding machinery for the production of slurry.

The smaller the material is crushed the better, within reason, as the expenditure of power for crushing is small in comparison with that required for the same reduction when carried out in the grinding mills, and incidentally the smaller the material the easier it is to handle, producing less wear and tear on the machinery feeding it into the mills.

It requires approximately 1.6 tons of limestone to produce one ton of cement, and in order to make a comparison with the previous figures given for the "Washmill" process it will be seen that to produce the same quantity of cement, viz. 36 tons, it will be necessary to crush

$$36 \times 1.6 = 57.6 \text{ tons per hour.}$$

It is found in practice to require in the neighbourhood of 2 b.h.p. to crush one ton of medium hard rock per hour down to 1 in. cube, and consequently the crushing of 57.6 tons will require

$$57.6 \times 2.0 = 115.2 \text{ b.h.p. per hour.}$$

In addition, power will also be required for conveying machinery and screening plant, which would bring up the power for the crushing plant alone to at least 150 b.h.p.

To convert the above amount of raw material (57.6 tons) into slurry it will be necessary to pass it through grinding machinery, the usual type employed for this class of material being a steel ball mill in combination with a tube mill ; the output of the latter in this instance would be from 9 to 10 tons per hour, and the number of mills required would consequently be

$$57.6 \div 10, \text{ say } 6.$$

It is found in practice that one steel ball mill and one tube mill of the above capacity when grinding limestone rock to slurry

having a fineness of 8 per cent residue on 180 by 180 mesh requires 325 b.h.p., and on this basis the power required for six mills will be

$$6 \times 325 = 1,950 \text{ b.h.p.}$$

To this must be added 150 b.h.p. previously found for the crushing plant, thus bringing up the total power required for the wet grinding portion of the plant to 2,100 b.h.p., as against 330 b.h.p. for a plant operating on chalk and having an equal output. Beyond this point the power required for the remaining stages of manufacture will be the same on either works, and it may be stated generally that where raw material of a hard nature is used the power required to reduce this material into slurry is equal to the amount of power required for converting the slurry into the finished product.

It will thus be seen that the class of raw materials used has a very important influence on the size of power plant required.

Having decided upon the process of manufacture, the type of machinery to be adopted, and the output of the works, it will be an easy matter to determine the total amount of power required and the size of prime mover to install, the makers of the various machines generally stating the amount of power required when operating under given conditions.

Where a large amount of power is to be used it will be advantageous to divide this up into a number of units, keeping these as large as possible on account of economical running, the reason for subdividing the plant being:—

- (1) To avoid total shut-down in case of accidents.
- (2) To facilitate overhaul and repairs which are always necessary and could not be carried out without stopping the works if only one prime mover were installed.
- (3) To allow certain portions of the works (e.g. raw grinding and cement grinding) to be shut down at week-ends and avoid using large units for producing only a small amount of power.

Owing to the severe nature and fluctuations of load met with in this industry it must be borne in mind that whatever type of power is employed, and especially where reciprocating engines are used, they must be constructed for continuous running, i.e. 168 hours per week, and capable of carrying at least 25 per cent overload just as easily as full load.

Too much attention cannot be paid to details, and it will be the duty of those responsible for the lay-out of the power plant to satisfy themselves that all parts, and especially wearing parts, are of ample dimensions for the work demanded of them. It does not follow that because an engine gives good service on a comparatively steady load like that found in the cotton industry, and

where only ten hours service are required daily with two stoppages in between, that the same engine will give as good running results on a cement works, and as a consequence they must be liberally designed; for instance, where a maker is of opinion that a 10 in. by 20 in. mainshaft bearing is ample, it may upon further consideration be wiser to increase these sizes to 11 in. by 22 in.

The foregoing statement is not intended to be looked upon as advocating alterations simply for the sake of making them, but where an improvement can be made, and the purchaser's engineer knows by actual experience the places which are likely to give trouble, it is his duty to place that experience at the disposal of the maker in order to obtain a result which will give satisfaction to all parties concerned, and the comparatively slight extra cost in the beginning will be more than amply repaid when set off against the loss of output alone, due to a few hours stoppage of the plant.

TYPES OF TRANSMISSION

The machinery in this industry lends itself to two types of transmission on account of a division line separating the process of manufacture into two distinct parts, viz.:—

- (1) The raw grinding mill.
- (2) The clinker grinding mill.

The first method of driving would be to install one or more engines according to the number of units to be driven in each of the above departments, and transmit power from the engine by means of ropes running in a rope race built alongside the mill, each engine driving its own set of mills; this would necessitate two complete power-houses, and on a modern works such an arrangement would render it necessary to install an electrical plant, also to drive some of the auxiliary machinery, which from the nature of its position with regard to the main units could not otherwise be driven in a satisfactory and economical manner; it is highly desirable to eliminate wherever possible all shafting and gearing, which is always a source of trouble owing to the dusty conditions under which it will have to work.

The second method of driving would be to construct an electric generating station of sufficient capacity to drive the whole works electrically, and install either gas- or steam-engines or steam turbines in the most suitable sized units.

The latter proposition offers the best all-round arrangement, even on works where so small an amount of power as 500 i.h.p. is required.

In order to give an idea of the methods of driving to be met with in practice nine instances are quoted in the table (p. 56).

Type of Engine.	Number of Engines.	Description of Drive.	Machinery driven.
Horizontal steam turbine . . .	1	Electrical.	For all machinery.
" " " " " "	2	"	"
" slow-speed steam	1	Ropes.	For wet-grinding machinery.
" " " " " "	1	"	For cement-grinding machinery.
Producer gas-engines . . .	3	Electrical direct coupled.	Kilns and auxiliary machinery.
Producer gas-engine . . .	1	Direct coupled to mill.	Wet-grinding machinery.
Vertical slow-speed steam . . .	1	" " "	Cement-grinding machinery.
High-speed vertical steam . . .	2	Electrical direct coupled.	Electrical for all machines.
Horizontal slow-speed steam	1	Ropes.	Wet-grinding and cement-grinding.
High-speed steam . . .	1	"	Cement-grinding.
" " " " " "	2	Electrical direct coupled.	Kilns, auxiliary machinery, and lighting.
Horizontal slow-speed steam	1	Ropes.	Cement-grinding.
Vertical " " " " " "	1	Ropes and electrical.	Cement-grinding and wet-grinding.
" " " " " "	1	Direct coupled to mill.	Wet-grinding.
Horizontal " " " " " "	4	" " mills.	Cement-grinding.
Vertical high-speed " " " "	4	Electrical direct coupled.	{ Kilns, auxiliary machinery, and lighting.
Horizontal steam turbine . . .	1	" " "	{ Kilns, auxiliary machinery, and lighting.
" slow-speed steam	2	Ropes electrical.	{ Kilns, auxiliary machinery, and lighting.
" " " " " "	1	Electrical direct coupled.	{ Kilns, auxiliary machinery, and lighting.
" " " " " "	1	Ropes.	Cement-grinding machinery.
Producer gas-engines . . .	4	Direct coupled to mills.	Wet-grinding machinery.
" " " " " "	4	" " "	Cement-grinding machinery.

Engines bracketed together formed one works.

The sizes of the engines in the table varied up to a maximum of:—

Steam turbines	1,500 kw.
Slow-speed steam-engines	1,000 i.h.p.
High-speed vertical engines	250 kw.
Gas-engines	400 b.h.p.

WATER SUPPLY

The locality of the works will be decided by the raw material, and as this usually covers a large area, the actual position of the works will be decided in a large measure by the water supply ;

the more abundant this is the better, as the choice of motive-power is not then restricted ; care must be taken that the supply will not fail during any part of the year, or that any portion of the works will be affected by floods, and the question of water rights must be carefully considered.

Too much attention cannot be given to the matter both as regards quantity and quality.

For general use the quality is not so important, but for steam-raising purposes this item is of vital importance, and a thorough chemical investigation must be made in order to ascertain what impurities are present, with a view to installing proper treatment so as to ensure suitable feed-water for the boilers. There are very few instances where it will not pay to adopt a suitable plant even in cases where the water is considered good.

The mere fact that the finished product of the works is cement is in itself a good index to the character of the water supply, on account of the geological formation of the land upon which it is situated, and the presence of scale-forming impurities may be looked for in considerable quantities ; in addition, the proximity of other factories, especially chemical, dye, and paper works, must be noted, as they often contaminate and make water unfit for use, generally due to corrosion of boiler plates and fittings, and the author has met with instances where air pumps and condensers have been utterly ruined by the presence of such pollution in river water.

Assuming the water to be hard, but otherwise good, it will simply be a matter of adopting treatment for the reduction of scale-forming materials, these generally being :—

Substance.	Chemical Symbol.	Common Name.
Sulphate of lime	Ca SO ₄	Plaster of Paris—gypsum
Carbonate of lime	Ca CO ₃	Chalk—marble.
Carbonate of magnesia	Mg CO ₃	—
Sulphate of magnesia	Mg SO ₄	Epsom salts.
Silica	Si O ₂	Sand.
Carbonate of iron	Fe CO ₃	—
Alumina	Al ₂ O ₃	—

Other impurities will be found present, but their effect is of a different nature, in some cases assisting deposition of scale, whilst in others, due to the action which goes on in the boilers at high temperatures and pressures, forming substances which cause pitting and corrosion ; for instance, magnesium chloride may produce hydrochloric acid, which is not very desirable inside a boiler.

The substances which may be classed as non-scaling impurities and usually found in few waters are :—

Substance.	Chemical Symbol.	Common Name.
Sodium chloride	Na Cl	Common salt.
„ carbonate	Na ₂ CO ₃	Soda ash.
„ sulphate	Na ₂ SO ₄	Glaubers salts.
Calcium chloride	Ca Cl ₂	—
Magnesium chloride	Mg Cl ₂	—

The scale produced varies according to the class of water and may be of the following characteristics :—

- (1) Soft scale.
- (2) Hard scale.
- (3) Sludgy sediment.

Each of the above has its own particular effect on a boiler, and it must not be considered that, because a certain water will not cause a hard incrustation which can only be removed by resorting to mechanical means or chipping, that it is safe to use without treatment, as it may in practice, generally due to the non-scaling impurities, cause serious trouble by pitting and corrosion, or priming together with oozing out at joints and fittings, the last two characteristics being especially noted where sodium chloride, or salt, is present, as in sea-water.

Each class of water must receive its own chemical treatment in order to rid it of its injurious properties ; the treatment is not difficult nowadays and will vary little in the majority of cases. The object must be to use a boiler for steam-raising purposes, and not a dumping-ground for all manner of impurities, chemical and otherwise, which come along with the feed-water, and to attain this end the most satisfactory way is to deposit these impurities outside and previous to entering the boilers, where the cost of dealing with them is a comparatively small item and a matter easily performed. It requires very little inquiry into the wages list to arrive at the conclusion that the removal of scale from inside a boiler, and especially a water-tube boiler, is a troublesome matter entailing a large amount of time and expense ; even in the case of the easily accessible Lancashire boiler, where fed with reasonably pure water, it is found to occupy practically all the time of one man to attend to the scaling of a battery of six or eight boilers, and to this must be added loss of economy due to the presence of scale, together with depreciation of the boiler, which must take place where scale exists, due to the overheating of the plates, slight perhaps where a small amount of scale is present, but increasing out of all proportion as the thickness of scale increases.

The chemical composition of the scale will determine its heat-resisting properties, and it is generally recognized that on the

average a thickness of $\frac{1}{8}$ in. offers a resistance to the passage of heat equal to that of 1 inch of asbestos.

If investigation proves the water after treatment to be quite adapted for boiler-feed purposes, then the type of softener selected should be of ample capacity, and it will always be found advantageous to pass the water from the softening plant into settling tanks and even an additional filter to ensure freedom of the water from precipitated salts formed in the softening plant.

Present-day water-tube boilers and high-speed engines demand water of the highest degree of purity obtainable, and even where gas-engines of large size are installed considerable benefit will be found by preventing scale forming in the water-jackets which in the majority of engines are practically inaccessible for cleaning purposes.

TYPE OF POWER PLANT

Few cement works will be situated so as to avail themselves of the purchase of electrical power in bulk, unless this is conveyed long distances; the addition of a continuous day and night load of 1,000 kw. or more would not assist a supply station to straighten out its peak loads; consequently, a comparatively small power station will not be able to cope with this additional load without endangering its capacity to deal with its own demands and would in all probability necessitate the laying down of new plant.

The cost per unit at which the required power could be purchased will be greater than that at which it could be produced on the works itself, unless there is some serious obstacle such as scarcity of water supply or difficulty of obtaining fuel; these conditions will very rarely happen, and as modern power plants of even small size are now designed to give the greatest economy, the most satisfactory course will be for a works to lay down a plant adapted to its own particular needs, and thus be independent of outside sources, together with the moral and legal complications which may arise. Being a commercial enterprise it will be necessary to install a plant having as its outstanding features reliability and economy.

The various types of power which may be adopted were mentioned previously, and on looking at the problem in the broadest possible manner, without prejudice to any particular type, it may be said that a Steam Power Plant will meet the peculiar needs of a cement factory more readily than any other, and when laid down as a Central Power Station permits the most economical generation of power coupled with the most ideal general arrangement of the works.

Assuming it is decided to use steam, the choice will lie between

- (1) Reciprocating steam-engines.
- (2) Steam turbines.

It must be borne in mind that power must be available at all times. On a plant with only one rotary kiln installed the demand for power will, to all intents and purposes, be governed by the successful running of the kiln, and should it become necessary to shut down this unit for any length of time the demand for power will automatically cease, though of course it will be understood that in the event of such an occurrence opportunity may be taken to fill up the slurry mixers if the level of these happens to be low, or to grind up any accumulated stock of clinker, the former taking not more than two or three days and the latter, say, a week's running.

With modern rotary kilns of 180 to 200 feet long, constructional details offer no difficulties to continuous running; it will, however, be necessary to make a stop of seven to fourteen days in order to reline the burning zone, say once every six or nine months, and it will therefore be seen that this point bears some influence on the subdivision of the generating units, introducing as it does on a plant having only a single kiln periods when small amounts of power are required.

It may be stated that a single kiln plant is not the most economical size to run, but as the power required will give the smallest amount necessary for a modern works it will probably be as well to consider whether a subdivision of the power units in so small a plant will be advantageous. The following figures give very closely the total amount of power required on single kiln plants having an output of about 1,000 tons per week:—

Raw Materials.	Power required.	
	I.H.P.	KW.
Chalk and clay, or similar soft materials	800	500
Limestone rock, or similar hard and crystalline materials .	1,360	850

As the works must for economical reasons be designed so as to produce all slurry and grind all clinker when working twenty-four hours each day during the week up to midday on Saturday, it will be realized that the load between this time and 6 a.m. on Monday is comparatively light, consisting only of the following:—

Power-house auxiliaries,
Slurry mixer,
Slurry pump,
Rotary kiln and auxiliary machinery,
Workshop,
Lighting,

absorbing at the most 125 kw., and as this power will only be required each week-end it is apparent that even on a plant

requiring 500 kw. as a maximum it will be advisable to install two units of 250 kw. each, since only one of these may be carrying half load for a continuous period of forty-two hours each week-end, and even though the larger unit would show a slightly more economical steam consumption the subdivision is advisable as a safeguard against total shut-down and also to assist carrying out maintenance and repairs which would otherwise be difficult. In order to note what the effect will be as regards steam and coal consumption by the subdivision of a unit of the size in question it will be as well to make a comparison of the different-sized engines proposed; assuming that reciprocating steam-engines are adopted, as would generally be the case where less than 500 kw. is required. The following table gives the steam consumption which may be expected under ordinary running conditions from well-designed slow revolution engines, and on this basis the figures will be calculated:—

Size of Engine.	Load I.H.P.	Boiler Pressure.	Superheat Temperature Fahr.	Vacuum L.P. Exhaust.	Steam Consumption per I.H.P. Hour.
500 kw.	{ 800	160	150°	26"	11.5 lb.
	{ 200	160	150°	26½"	13.5 lb.
250 kw.	{ 400	160	150°	26"	12.5 lb.
	{ 200	160	150°	26½"	13.5 lb.

800 I.H.P. Engine.

126 hours × 800 i.h.p. × 11.5 lb.	1,159,200
42 ,, × 200 ,, × 13.5 lb.	113,400
<u>168 hours.</u>	<u>= 1,272,600 lb. steam.</u>

400 I.H.P. Engine.

126 hours × 400 i.h.p. × 12.5 lb. × 2 engines	1,260,000
42 ,, × 200 ,, × 13.5 lb. × 1 engine	113,400
<u>168 hours.</u>	<u>= 1,373,400 lb. steam.</u>

Or a difference of $1,373,400 - 1,272,600 = 100,800$ lb. steam per week.

Which, on the basis of an evaporation of 8 lb. water per lb. coal, shows a saving of 5.6 tons of coal per week in favour of the large-sized unit.

In the event of there being no intention to increase the capacity of the works beyond the output of one kiln, the course to adopt would be the installation of the two smaller-sized power units, but in the event of the works being laid down with the idea of extending, it will be advisable to consider what the maximum

amount of power required will be, and if possible arrange the first power unit so as to be similar in size to the others finally installed.

This will probably give a larger size than would otherwise be installed, and unless it is intended to carry out extensions very soon after starting up the works, the advisability of providing a small power unit capable of economically carrying the week-end load and acting as a standby should be considered.

Such a unit, if arranged for in the early days of construction, would practically pay for its cost before manufacture was commenced by providing light and power, thereby saving much valuable time in the completion of the works, and would be of great value as the time of starting up approached, when perhaps for many weeks there may be one machine here and another there to be tried round, and yet not sufficient power required to warrant running a large-sized unit.

CHOICE OF POWER UNITS

The type adopted depends upon the method of transmitting the power to the various mills and was mentioned previously ; it will not be out of place, however, to enumerate the various arrangements which may be found in practice :—

- (1) Engine so situated that the crankshaft may be extended to run the full length of the mills and drive each mill by means of ropes or belts through friction clutches.
- (2) Engine driving direct by means of ropes or belt on to a second motion shaft and thence to each mill by means of ropes or belts through friction clutches.
- (3) Engine driving generator through ropes or belt and mills electrically driven.
- (4) Engine direct coupled to generator and mills electrically driven.

In the first three instances reciprocating engines would, for practical reasons, be installed ; in the last instance either reciprocating engines or steam turbines could be adopted.

On point of economy there is not much to choose between either type up to 500 kw., but beyond this the argument is all in favour of the turbine on the point of lower steam consumption, smaller cost of foundations, steadiness of running, reduced oil bills, and the fact that no oil is contained in the condensed steam, thus enabling the condensate to be used for boiler feed and requiring only a small amount of make-up water.

The economical steam consumption of a turbine is chiefly due to the fact that it is suitable for operating with highly superheated steam, and can deal with the enormous volume which a given quantity of steam will occupy when expanded down to low

pressures, thus enabling the turbine to make use of high vacuum and extract as much energy as possible out of the steam; consequently, in order to ensure sustained economy, it is necessary to run with as high and as steady superheat as possible, and maintain the condensing apparatus in the best possible condition, keeping a watchful eye for any possible air or other leakages which would vitiate the vacuum.

The reciprocating engine, on the other hand, cannot avail itself of the same high degree of vacuum as a turbine, and on account of constructional difficulties it would be impracticable to make an engine having the enormous size of L.P. cylinder and large-sized valves, steam passages, etc., required.

On the point of superheat also this type of engine demands the greatest amount of skill and experience to be placed behind its design if it be desired to make use of steam superheated, say 150° F. The oils used must be of the highest class, free from any tendency to carbonize, otherwise serious trouble will arise and steam consumption go up due to piston and valve packing rings sticking in their grooves, with all the attendant troubles such as scoring cylinders, etc.

In any case, whether steam at saturation temperature or superheated steam is employed, too much attention cannot be paid to the above details by both the purchasers and makers of an engine, as these points are almost vital to successful economy where a steam-engine is concerned.

The design and manufacture of both the preceding types of prime mover are now based on well-tried lines, each maker possessing their own standard designs embodying ideas and experience, often gained at considerable expense; as far as the turbine is concerned very little improvement can be made to those now on the market, and these are usually well equipped with accessories and fittings. The mere fact that these machines run at high speeds must have very fine clearances and condensing apparatus capable of producing the best possible vacuum, leaves no option for the maker to supply other than the best design, material, and workmanship. Steam-engine makers of late years have been paying greater attention to design in order to ensure economy, but it is notable that quite a number when submitting prices and designs, like to adhere to the old-fashioned method of including as few accessories as possible and stating that if an indicating gear, revolution-counter, or particular gauge is required this will be an extra. In a similar manner many appear to think owners will never waste time testing an engine occasionally, and therefore do not make provisions such as fitting thermometer pockets where necessary.

A great deal more intelligent interest is taken nowadays by those responsible for the upkeep of prime movers in order to

obtain the best working results, and there is therefore no reason why makers should not make provisions for assisting observations; probably these items are stated as extras in order to show the purchaser the lowest possible price the engine alone can be supplied for.

In arriving at a decision as to what prime mover to purchase, the chief point is that of fuel economy; each offer must be reduced to the same conditions and considered on its merits. In order to simplify this matter, makers must have these conditions clearly stated to them, otherwise the steam consumption may be stated in any of the following ways which may or may not include power required for driving auxiliary plant such as circulating pumps and air pumps:—

Steam per kw. per hour.

Steam per i.h.p. per hour.

Steam per b.h.p. per hour.

Any of the above may also be arrived at in more ways than one; for example, measured as water fed into the boilers, measured as condensed steam from the surface condenser.

The first method is generally adopted for engines equipped with jet condensing plants, and gives a result which is slightly higher than the true steam consumption owing to the leakages which may take place between the feed-water measuring tank and the engine stop valve; the difference generally being made up of the following losses, viz.:—

From feed-water pipe joints.

Safety valves.

Boiler blow-off cocks.

Economizer relief valves, blow-down valves and joints.

Steam-pipe joints.

Steam traps.

Inaccuracy in reading water-level in boilers at finish of test.

Condensation in steam-pipes.

The majority of these would be guarded against during a test, but the last item is one which cannot be eliminated altogether. Where a test is conducted by measuring the condensate from a surface condenser, the result gives the amount of steam which has passed through the engine, and this figure represents more correctly the actual steam consumption.

It would therefore be obviously unfair to compare the guaranteed steam consumptions of engines offered by different makers without considering in which manner the test figures would be arrived at, and it should further be stated over what period the test must last. In a cement works there will be no difficulty in arranging a test of at least eight hours; anything less should not be considered, as snap tests of short duration are

apt to give misleading results ; an engine must not be accepted on these tests alone, and it should be demanded that it is able to carry full load for a continuous period of at least 168 hours without undue trouble.

Very often, in spite of all preparations for an official test, it so happens a slight variation will be found in the degree of superheat and the vacuum obtained, and as these figures affect the steam consumption in a very marked degree it will be necessary to make an allowance for these differences, and in order to avoid any misunderstanding as to what corrections may be made it is advisable that these figures should be previously agreed to and inserted in the specification.

The initial cost of the engines will naturally be the first item considered by the purchasers, but a final selection should not be based on this figure only ; the most important point to be considered is that of fuel economy, and even this must not be considered alone, as an engine which may be guaranteed to possess, and in fact may possess, a low steam consumption at the beginning of its life, can very easily lose its pristine economy after a few months wear and subsequently prove a very uneconomical unit to run ; consequently, the greatest criticism must be paid to the vital points of the designs offered which bear an effect on sustained economy, otherwise the purchasers may be saddled with a considerably higher yearly fuel bill than was anticipated. This point will easily be realized when it is considered that an increased steam consumption of 1 lb. per h.p. hour on an engine of 1,000 i.h.p., working 168 hours per week, will require under the most favourable conditions an additional coal consumption of 9 tons per week.

The economical running results obtained from modern internal combustion engines, due to their high thermal efficiency, makes this type of motive-power one which must not be overlooked.

There are quite a number of excellent designs on the market, and this fact makes the matter of choice a problem of considerable difficulty in order to ensure obtaining the right type of engine ; in fact, the problem should only be undertaken by an engineer having an intimate knowledge of this class of prime mover and the nature of the service which will be demanded of it, otherwise indifferent results and considerable trouble will certainly accrue.

The extremely heavy and comparatively slow-running type of gas-engine may be looked upon as hardly the type which would be adopted on a new works. Of recent years the light multi-cylinder type, running from 200 to 300 r.p.m., has been brought to a very high pitch of perfection, and will be found a good type to adopt in sizes from 250 to 1,000 b.h.p. when working in conjunction with a gas-producing plant, and provided this is sufficiently large to warrant the installation of a plant for the

recovery of by-products, the revenue earned will prove a valuable help towards reduction of running costs.

The characteristic points of an internal combustion engine may be summarized as follows :—

- (1) When operating at full load have a high thermal efficiency in the neighbourhood of 30 per cent as against 12 to 15 per cent obtained with steam-engines.
- (2) Have practically no capacity for overload.
- (3) Massive construction due to high-cylinder pressures.
- (4) Cylinders require water-cooling owing to high temperatures generated, and in some instances pistons and piston-rods are water-cooled.
- (5) Capital outlay is higher than that for a similar-sized steam-engine and boiler, etc.
- (6) Reliability and ease of starting do not compare so favourably with steam-engines.
- (7) Frequent periodical opening up to clean out carbon deposit, and grind in valves, etc., render it imperative to have one engine almost always out of commission.

BOILER PLANT

The type of boiler selected will depend chiefly upon the amount of steam required per hour, the quality of feed-water, and the class of fuel available.

In a well-arranged works the demand for steam will be of a comparatively steady nature throughout the week, and the field of selection may be narrowed down to :—

- (1) Water-tube boilers.
- (2) Drum type boilers.

The former may be divided into two classes, viz.:—

- Straight tube boilers (e.g. Babcock).
- Bent tube boilers (e.g. Stirling).

These boilers are constructed in sizes capable of evaporating over 30,000 lb. water per hour and will carry considerable overload ; they are suitable for dealing with sudden demands owing to their capacity for rapid steam-raising, and have been proved to possess a better evaporative efficiency than drum type boilers.

The majority possess the disadvantage of numerous joints, and demand feed-water of the best quality in order to avoid attendant troubles due to scale, etc.

On the other hand, the drum type boiler, which is represented by

- (1) Lancashire boilers,
- (2) Yorkshire boilers,

will only evaporate about 12,500 lb. water per hour with the largest sizes ; they do not respond so rapidly to increased demands

for steam as the water-tube type, neither are they quite so economical; they, however, have the advantage of accessibility, thus enabling every possible part to be thoroughly cleaned and inspected with ease each time they become due for cleaning.

The amount of repairs required by this type of boiler are extremely small in a well-cared-for plant, and there is always the certainty that when put into commission after being off for cleaning, etc., practically no trouble need be anticipated unless caused by gross carelessness.

Where trouble may be anticipated on account of the nature of the feed-water supply, the best class of boiler to install will undoubtedly be the drum type, though of course the provision of a water-softening plant would allow either class of boiler to be adopted without hesitation.

There will always be a slight formation of scale however well the softening plant performs its duty; in fact, it is not wise to carry out the water-softening process to such a degree as to eliminate every particle of scale-forming material, the use of oversoftened water being quite as bad as using water which has not been treated at all.

When laying down this part of the plant care must be taken that the boiler settings are properly designed, and all risk of cracks and air leakages eliminated where possible; provision must be made so that the flues are easily accessible, and flue dust, etc., is removable with the least amount of labour and trouble, otherwise this necessary work which has often to be carried out will not be performed as efficiently as it should be by those whose duty it is to perform this task.

The arrangement of the flues must be carefully thought out so as to facilitate cleaning, and where an economizer is installed the arrangement of the flues must be such as will permit these being cleaned at proper intervals whilst the boilers are at work, without trusting to the opportunity, which never arises when it should, that the works will close down at some future date for a few days holiday, with the result that this part of the plant will not be cleaned as often as it should, and will be working under unfavourable conditions for a large portion of its time.

In the event of the flues being arranged so as to pass the flue gases either through the economizer or direct to the chimney, as desired, it will very readily be noticed during cleaning operations what a beneficial effect an economizer has on the reduction of the fuel bill, and where any considerable load is being carried the reduction in temperature of the feed-water will very likely demand an additional boiler being put into commission, with the resultant increase in the weekly coal bill. It will therefore be wise in instances where a fairly large economizer is installed, to consider the expedient of so arranging it that one half can

be laid off for cleaning whilst the other half is in use. Such an arrangement will be of benefit to the boilers as doing away with feeding with comparatively cold water, and would allow cleaning operations to be carried out at proper stated intervals independently of conditions on the works, and the saving in fuel during these times will more than pay for the cost of labour required for these operations.

It is always a wise plan to fit a "tell-tale" pressure gauge in order to record the maximum pressure obtained on the economizer and thus act as a safeguard against carelessness in handling the feed pumps; in addition substantial thermometers should be fitted at the inlet and outlet so as to keep track on the temperatures obtained, as feeding water at less than 90 to 100° F. will induce sweating at the bottom ends of the pipes with resultant corrosion and wasting away; whilst the outlet temperature will show whether the economizer is performing its duty.

FEED PUMPS

These must be selected with an eye to economy and reliability; the type will depend in a measure upon the design of the powerhouse itself.

A failure of water supply for the boilers will mean a total shut-down for the works unless the defect can be remedied in a very few minutes, therefore it becomes necessary to make provision for a standby.

In the case where a reciprocating steam-engine of the slow revolution type is installed, a common arrangement is to drive the feed pump from the air-pump levers; in such cases a very simple and economical type of pump may be fitted and a standby pump of the steam-driven reciprocating type is arranged to feed the boilers when the main engines are stopped.

A plant arranged for electrical driving and having either steam turbines or quick revolution engines could not adopt the preceding arrangements in its entirety; the tendency nowadays in such instances is to use the multi-stage or turbine type centrifugal pump, which may be direct coupled to an electric motor or small steam turbine, the latter running at speeds in the neighbourhood of 3,000 to 4,500 revolutions per minute; such pumps have very small clearances and it is essential the water they are called upon to handle must be reasonably free from scale-forming matter, otherwise trouble will be experienced due to the small water passages becoming restricted in area with the result the pump will not "face the boilers". In order to ensure the highest economy with this type of pump it is essential that the interior must be machined wherever possible to reduce skin friction and

retard scale formation ; the impellers also must be made of metal which will resist corrosion.

Both the electrically and steam turbine driven type of pump have proved efficient and capable of running many months at a stretch without stoppages of any kind, requiring little attention beyond oiling the bearings; and as an instance of this, a pump of the steam-driven type under the author's care has run for periods of six months without any stop, at a speed of 4,150 r.p.m., during which time the number of revolutions made amounted to the very respectable total of considerably over one thousand million, to be precise 1,087,632,000. An examination of the pump after this run showed absolutely no signs of wear, and it may be said the stoppage was solely made to give the pump a rest.

A valuable feature of their operation is noticeable in the reduction of stresses in the feed-water pipes, thus eliminating vibration and leaky joints both in the pipes themselves as well as the economizers. The choice of method of driving may be a matter of individual taste, though the decision should not be allowed to rest at this stage, as there are other important points to consider ; the pumps will be continuously in operation, and it will be advisable on this account to install a design which has been proved in practice to give economical running results and should be purchased from a firm which specializes in this class of work.

Prices quoted may vary considerably, and a comparison will probably show the cheapest pump is either :—

- (1) Unsuitable for the work required.
- (2) Inferior in design and material.
- (3) Not properly equipped, entailing expense afterwards.
- (4) Considerably smaller in size.

If the latter, the pump will of necessity have to run at a proportionately higher speed to obtain the output, meaning in the case of a steam-driven reciprocating pump, reduced economy and additional wear and tear.

The electrically driven type of pump will be the most efficient as regards its power end, since this will be produced by the main engines ; the pump portion, however, will only have an efficiency in the neighbourhood of 65 per cent, and further, the pump cannot be used when the main engines are shut down, or when starting up the works, until current has been delivered to the main switch-board.

The steam turbine driven pump will have the same efficiency for its pump end as the above, but for the steam end, owing to the small size of its power unit, will require at least three to five times as much steam per h.p. according to the size of pump, and will therefore appear at first sight a very extravagant type

to adopt; an investigation, however, will show this is not the case, and the following figures will explain this statement more clearly:—

Assume main engines	1,500 i.h.p.
Steam consumption per i.h.p. hour	11½ lb.
Steam pressure at boilers	180 lb.
Steam consumption of turbine feed pump	70 lb. per h.p. hour.
Efficiency of water end of feed pumps	65 per cent.

The total amount of water to be fed into the boilers will be somewhat greater than that required by the main engines in order to make up for the various losses and also that used for other purposes, and is usually found in plants of this description to be in the neighbourhood of 15 per cent; the pump itself must also be designed to work against a pressure of at least 20 per cent greater than the boiler pressure, to allow for the friction in the feed-water and economizer pipes and provide sufficient excess pressure to pump against boiler pressure.

In the case under consideration,

Feed-water required per minute will be

$$= \left(\frac{1,500 \times 11\frac{1}{2}}{60} \right) + 15\% = 330 \text{ lb.}$$

Manometric head

$$= (180 \times 2.30) + 20\% = 497$$

say 500 ft. head.

Power required will be

$$\frac{330 \times 500}{33,000} \times 65\% = 7.7 \text{ h.p.}$$

Steam consumption of turbine-driven pump

$$= 7.7 \text{ h.p.} \times 70 = 539 \text{ lb. per hour.}$$

Equivalent steam consumption of electrically driven pump

$$= 7.7 \text{ h.p.} \times 11\frac{1}{2} \times \text{efficiency of engine and generator} \times \text{efficiency of motor} = 105 \text{ lb. per hour.}$$

The electrically driven pump uses up all the power supplied for its operation; the main engines, as producers of this power, having only made use of a very small percentage of the available heat in the steam which could be charged against the pump; on the other hand, the steam used for the turbine pump after performing its useful work in the pump may on account of its freedom from oil, be exhausted directly into the hot-well or feed-water tank at a pressure of 2 to 5 lb. per square inch, still possessing, due to its latent heat, a very large heating value, capable of raising the temperature of the feed-water to a temperature which will effect considerable economy on the coal bill.

There are several conditions which will affect the initial temperature of the feed-water, e.g. where a jet condenser is

employed, the condensed steam mixes with the cooling water and the resultant mixture is not usually used again unless of good quality and free from scale-forming matter; the final temperature of this water usually varies from 100° F. to 140° F., according to the vacuum produced; some of this heat would be lost before the water reached the feed-water tank, and the temperature in this instance will probably be 10° lower than the above figures.

2. In the case where a high-class reciprocating engine is employed in conjunction with a surface condenser, the condensed steam may be used again with the addition of a small amount of water for make-up purposes, and an engine of this type operating with a vacuum of 26 in. in the L.P. cylinder would generally show 28 in. vacuum in the air pump, which is equivalent to a temperature of 100° F., and the mixture of condensed steam and make-up water would give a final temperature of, say, 85° F. in the feed-water tank.

3. With a steam turbine it is of course essential to carry as high a vacuum as possible, and to attain this end a very large amount of cooling water must be used, with the result the condensed steam is reduced to a temperature not exceeding 10° F. greater than that of the cooling water or, say, 70° F.

4. Where the feed-water is simply taken from the works water supply the temperature will usually have a mean of 60° F.

In the above instances, where it is necessary to pass the boiler feeder through a softener prior to delivering into the feed-water tank, it may be found advantageous to heat the water with live steam to assist precipitation of scale-forming salts, in which case the temperature leaving the softener may be as high as 180° F. with an open tank, when the ventilation of the pump-house must receive careful consideration to prevent deterioration of the roof due to rusting, or rotting of timbers, and avoid the unpleasant appearance of dripping walls and pipes in cold weather.

Taking case No. 2 and assuming a feed-water temperature of 85° F., we will now consider the comparative efficiencies of the two pumps under consideration:—

- (1) Electrically driven pump, 105 lb. steam per hour.
- (2) Steam turbine driven pump, 539 lb. steam per hour.

In the first instance no further gain can be obtained from the steam employed, this being all used in the main engines; the hotwell temperature will therefore remain 85° F.

In the other case the exhaust steam will have a pressure of not less than 5 lb. per square inch above atmosphere corresponding to a temperature of 228° F., and will contain the following heating power:—

$$\begin{aligned} & \text{Latent heat } 960 + (228 - 32) \\ & = \text{Total heat of } 1,156 \text{ B.T.U. per lb. of steam.} \end{aligned}$$

This heat is available for heating the feed-water, and will raise its temperature in the case under consideration to 112° F., or an increase of

$$112 - 85 = 27^{\circ} \text{ F.}$$

The effect of this difference of temperature may have either of the following results on the boilers :—

- (1) To decrease the coal consumption for the same evaporation.
- (2) To increase the evaporation for the same coal consumption.

Applying the latter effect, the amount of heat required to be put into each pound of water evaporated by the boilers at 180 lb. per square inch is—

$$\begin{aligned} \text{Latent heat + (temperature of steam — temp. of feed-water)} \\ &= 845 + (379.8 - 112) \\ &= 1112.8 \text{ B.T.U.} \end{aligned}$$

The increased evaporation for the same fuel consumption will be

$$\frac{\text{lb. water evaporated per hour} \times \text{rise in temp. of feed-water}}{\text{Total heat in 1 lb. of steam}}$$

$$\frac{330 \times 60 \times 27}{1112.8} = 480 \text{ lb. steam per hour.}$$

This amount of steam should rightly be credited to the turbine pump, and consequently the net amount of steam used by it will be

$$539 - 480 = 59 \text{ lb. per hour,}$$

as against 105 lb. previously found for the electrical pump.

Looked at in another way which will probably be more readily appreciated, the saving in fuel, based on a running week of 168 hours and a boiler evaporation of 8 lb. water per lb. of coal, is

$$\frac{480 \times 168}{8 \times 2240} = 4.5 \text{ tons per week.}$$

Both the foregoing types of pump entail a fairly large capital outlay, and though this is not really a very large item it will not do to dismiss the subject at this point as there still remains the well-known and faithful steam-driven reciprocating pump, which has been modernized so as to give very economical results.

The efficiency of the water end of these pumps when the feed tank is in the same level or has a slight head above the pump barrel is high, and consequently the h.p. for a similar duty is somewhat less than that required for the preceding pumps; the steam consumption per hour h.p. is also somewhat less than that of the turbine pump, due to the fact of the steam being used expansively.

Owing to the fact that oil is present in the exhaust, this cannot be used for feed-water heating unless previously passed through an oil separator, or through a heater designed so that the steam does not come in contact with the feed-water.

It will be imperative to have a steam-driven pump for a standby, and either of the following combinations may be adopted:—

- (1) Electrically driven centrifugal pump and steam turbine pump.
- (2) One steam turbine pump and one vertical reciprocating steam pump.
- (3) Two vertical reciprocating steam pumps.
- (4) Two steam turbine driven pumps.

Either of the first three arrangements would usually be adopted, though it may be mentioned that the adoption of steam-driven pumps will have the advantage of rendering the boiler plant independent of the power-house.

STEAM AND FEED-WATER PIPES

The general practice is to use pressures varying from 120 lb. to 180 lb. per square inch and superheat the steam, in some cases to a final temperature of 600° Fahr.

Reciprocating engines are found to give good running results with a superheat of 100° F. This is generally sufficient to ensure the steam being dry at the L.P. exhaust, and 150° F. appears to be the maximum advisable superheat to employ with this class of engine. On the other hand, the design of steam turbines and their freedom from lubricating oil allows the use of higher pressures and superheat, generally in the neighbourhood of 200° F., and instances of 250° F. are met with.

The accepted materials from which pipes are usually made are:—

Cast iron,
Wrought iron,
Mild steel.

No modern plant with any pretensions to size or economy will have a boiler pressure so low as 100 lb. per square inch, and this may be considered as the limit of pressure up to which cast iron should be employed, especially if superheated steam is used owing to the increased expansion and deterioration of the metal which is liable to take place at high temperatures.

The materials which are almost invariably used are wrought iron and mild steel, the tensile strength of which allows the pipe to be comparatively light and thin, at the same time providing a high factor of safety; such pipes have also a

considerable amount of flexibility and are better able to cope with the strains due to expansion and sometimes "water hammer" which may take place, either due to errors of design or carelessness on the part of attendants.

According to size they are usually supplied in lapwelded or solid drawn steel from 2 in. to 20 in. diameter, and may be in straight lengths or bent to suit any particular requirement; flanges are generally of weldless steel, stamped out of the solid and welded on, though in some instances cast steel flanges are used; both types may be faced straight across or made spigot and recess.

For all-round work lapwelded steam pipes with solid welded flanges and branches either welded or riveted on will be found to satisfy all requirements for pipes from 2 in. to 12 in. bore, and for sizes above this flanges and branches are preferably riveted on. The usual thickness for mild steel steam pipes for pressures up to 200 lb. per square inch may be taken as—

3 in. to 7 in. diam. inclusive,	$\frac{1}{4}$ in. thick.
8 in. to 10 in. " "	$\frac{5}{8}$ in. "
11 in. to 12 in. " "	$\frac{3}{8}$ in. "

The material from which bends are made should always be several gauges thicker than that used for straight lengths.

Owing to the length which this type of pipe may be made the number of joints are considerably reduced, and in order to secure the best results these should be made of the thinnest possible material; soft brass corrugated rings covered with a putty composed of red and white lead; or one of the many jointing compounds now on the market may be used for the purpose, or as an alternative high-pressure asbestos sheeting $\frac{1}{8}$ in. or $\frac{1}{16}$ in. thick smeared over with boiled oil, either of which methods will be found to give good results.

Bolt holes should always be drilled and spaced according to some definite system, preferably the British Standard dimensions, so as to ensure interchangeability.

Arrangements must be made in the layout to allow complete freedom for expansion, and proper supports and anchors provided where necessary; drainage also must receive careful attention.

The tendency in the design of many power plants is to consider the steam pipes as the subject of a separate and distinct contract from that of the boilers; in such instances it is possible that the system adopted may not be suitable for obtaining the most economical results or the best arrangement; for instance, the design suitable for a works operating ten hours per day will not entirely meet the requirements of a plant running continuously.

Each contractor will be satisfied to carry out the particular work allotted to him as conscientiously as possible, but whether the final result obtained is satisfactory is a matter which is no concern of his, consequently the whole matter must be carefully schemed out and working drawings made before any work is undertaken, or failing this, the whole layout of the boilers and pipes undertaken by one contractor, preferably the boiler-makers.

A visit to a well-arranged and carefully supervised boiler plant with everything in good working order, no signs of leaky joints, etc., does not convey very much to the lay mind, it all looks so very simple; but when one reflects upon the enormous pent-up energy throughout the system it may be easily realized that the dangers in connexion with modern high-pressure plants are such that it is essential the design, erection, and running must only be in the hands of competent men. Not only must the system be such as to ensure safety and economy, but arrangements should be made that where possible repairs may be carried out during ordinary working hours without impairing the running of the plant.

In order to comply with legal requirements it is essential that this portion of the plant be thoroughly examined at stated times by a competent person, and as the attendant risks are usually undertaken by some recognized Insurance Company such examinations are carried out by their qualified inspectors, at periods not exceeding fourteen months intervals. Such examinations, of course, do not relieve those in charge of the boilers of their own responsibility, and it is their duty also to make a daily tour of inspection and also examine every boiler, both internally and externally, each time it is off for cleaning purposes.

In view of the fact that the boilers and pipes will undoubtedly be insured, the best course that can be adopted is to make arrangements with a Company who undertake such insurances, and after settling the arrangements of the plant to allow this Company to inspect both the boilers and pipes during manufacture, both as regards raw material and details of construction. Every effort must be made to secure economy of operation, and as fuel cost will be the largest item of expenditure it is necessary that every heat unit put into the steam must be used usefully; the pipes must be covered efficiently so as to reduce radiation losses to the lowest practicable limit. All water due to condensation in the main pipes or from steam traps, etc., should wherever possible be returned either to the hotwell or collected and returned direct to the boilers.

In most cases this water is very near to boiling-point and

contains a considerable heating value; a few moments observation of, say, a steam trap, under working conditions, will soon give an idea as to the amount of water which can be thrown away due to this cause alone; it may not appear much at first sight, but goes on week after week, amounting to quite a large figure at the end of the year, and a little calculation will show how much coal has been used to no purpose by allowing such a waste.

On the other hand, a steam trap may have valves which are not of a suitable material to deal with superheated steam; the frequent regrinding of these becomes irksome to the man appointed to carry out such repairs, when he will probably hit upon the brilliant expedient of connecting the discharge up to a drain. Out of sight is out of mind, and unless there is someone on the job with a curious turn of mind, it will not be long before it is simply a case of blowing away live steam and consequently money, which will be charged against running costs; it is therefore a wise plan to adopt a system for the collection of all possible leakages and return them to the boilers as stated above.

SUPERHEATERS

In practically all cases these are arranged at the back end of each boiler in the downtake and obtain their heat from the flue gases, leaving the internal flues of the boilers. There are quite a number of designs on the market, all of which have been installed with considerable success; their manufacture is generally a speciality and the outcome of much experience; their design and the material employed leave little to be desired; in fact, the construction of the top boxes into which the tubes are fitted is a very high-class piece of workmanship. In all cases it is imperative they should be fitted with the following accessories:—

Cast-iron bearer plates for carrying the superheater on the brickwork.

Spring loaded safety valve.

Thermometer pockets and thermometer reading to 600° F.

Draining valves.

Isolating plates or dampers.

The economy due to using superheated steam is considerable, and for rough calculations it may be taken that if the steam is sufficiently superheated to ensure dryness but no superheat at the engine stop valve a saving of 5 per cent will result; the further addition of superheat beyond this point will show a reduction in steam consumption of 1 per cent for each 10° F. of

added superheat, and it is usually accepted that the following saving may be obtained :—

60° F. superheat	. . .	5	per cent
80° F.	„ . . .	10	„
100° F.	„ . . .	14	„
150° F.	„ . . .	20	„
200° F.	„ . . .	25	„
250° F.	„ . . .	30	„

CHAPTER VIII

MISCELLANEOUS

STORAGE AND PACKING

PROVISIONS must be made for storing cement, because the process of manufacture is continuous ; sales are not, there are periods of slackness or abnormal demands.

Different classes of work require different setting times—quick, medium, and slow.

Many users of cement prefer not to accept the cement if it is many degrees above the temperature of the air.

All cement used on large contracts is sampled at the factory ; approximately equal portions are selected from twelve different positions in the heap, or heaps, from each 250 tons or part thereof, and these must be held until approved and required.

This, of course, necessitates extensive storage arrangements, at least a month's output, for cement.

The cement will, in most cases, improve by storage, especially if it can be so stored that air can get at the mass.

CEMENT STOREHOUSES

The typical design in Great Britain consists of a long low frame building, divided into bins by means of wooden partitions. These bins hold 250 to 500 tons.

The cement is brought from the grinding mills by overhead screw conveyors, spouts being arranged to the centre of the bins from openings in the trough of the conveyor controlled by slide valves.

Covered loading platforms are so provided that the cement may be loaded direct on to a wharf, if the works are on a canal or river, or on to a railway.

Recently reinforced concrete silos have been introduced, but should be a matter of much deliberation before being undertaken, especially if space is not a consideration, for the following reasons :—

Initial cost : long experience has demonstrated that if a saving is necessary it should be effected on the buildings and not on the machinery, which must be of the heaviest and best.

Difficulty in getting an average sample from twelve different positions in the heap, as recommended by British Standard Specification.

Cement adhering to the sides of the bins, and as the bin is being emptied lumps frequently falling and possibly spoiling the shipment.

Cost of cleaning down the walls of the bins and regrinding the cement.

Elevating to top of silo.

If automatic packing machinery is required equal facilities are afforded in the ordinary storehouse as in the silo.

PACKING

Cement is packed in wooden barrels or steel drums for export or coastwise shipment, and mostly in sacks for the inland market.

Barrels and drums vary in size, the usual capacity being 400 lb. net or gross, although at times smaller sizes are used.

Sacks mostly used are 10, 11, and 12 to the ton.

All packages are clearly marked with the brand of the Company for identification.

In the case of sacks, these are purchased from the manufacturers, the freight charges being no more for the completed sack than the material, but with wooden barrels and steel drums conditions are very different.

Although cement manufacturers may purchase them from an outside source, the freight charges are very high, the capacity of a barrel or drum being approximately 4.0 cubic feet.

A factory producing 3,000 tons of cement weekly would require—

Sacks, ten to a ton, 30,000.

Barrels or drums, 400 lb. net, 16,800.

So it will be at once apparent what a very important question the packing for exporting cement is, and in estimating the cost for a Portland Cement plant the machinery for the manufacture of barrels and steel drums should be figured in.

The manufacture of casks and barrels by machinery is a subject which has constantly claimed the attention of inventors and engineers, and the fact that nearly a thousand patents have been taken out in England and America in the last century for improvements in cooerage is a sufficient proof of the importance attached to this question. It is worthy of note that British firms are quite without rivals in the production of machinery for the manufacture of casks and barrels, also for steel drums.

SACK DEPARTMENT

The sack question is a most important one, and this department must be well organized before starting a factory; *unfortunately, those unacquainted with the industry give no*

thought to the preparation of this necessary section, causing trouble and extra expense afterwards.

In the first place, storage must be considered ; assuming you are estimating for an output of 3,000 tons of cement per week, half this quantity will be loaded into sacks, take ten to the ton, 15,000 weekly, probably two months will elapse before sacks begin to return, hence you will require to start with 120,000 sacks, provision being made for another 120,000, say, six weeks after starting.

This means storage capacity for at least 250,000 sacks.

A sack-drying, cleaning, and mending plant must be provided. The sacks are returned invariably in very bad condition.

If proper mechanical appliances are installed no great expense or difficulty is incurred ; on the other hand, if no means have been provided endless expense is entailed in cleaning, drying, and mending by hand ; sacks are never ready when required, and many men are engaged. A cost, if continued for any length of time, would have paid for a proper layout.

Sacks returned from customers are checked and recorded on the daily return form by the foreman.

The consumer is charged with the value of the sacks, with a rebate for returned sacks.

MECHANICAL EQUIPMENT

- (1) Sack-cleaning machine.
- (2) Drying apparatus.
- (3) Sewing and darning machines.

EQUIPMENT FOR MACHINE SHOP

- One 12 in. centre lathe.
- One 6 in. centre lathe.
- One planing machine 6 ft. by 2 ft. bed.
- One shaping machine to 24 in. stroke.
- One radial drilling machine 5 ft. radius.
- One sensitive drilling machine.
- One screwing machine :
 - Whitworth, $\frac{3}{8}$ in. to $1\frac{1}{2}$ in.
 - Gas, $\frac{3}{8}$ in. to 3 in.
- One grindstone.
- One coarse emery wheel.
- One tool emery wheel.
- One hack saw.

All the above machines to be power-driven and equipped with the usual accessories.

Lifting appliance to be provided to deal with heavy material.

Modern hand tools to be available to enable repairs to be met and completed promptly.

SMITHY

Three blacksmith fires with power blast.
One punch and shearing machine.

CARPENTERS AND WHEELWRIGHTS

One circular saw bench.
One planing machine.
One band saw.

CHAPTER IX

COSTS AND STATISTICS

COSTS OF THE MANUFACTURE OF PORTLAND CEMENT

THE cost of installing a Portland Cement plant, owing to problems into which many factors enter, varies within wide limits, and it is therefore wellnigh impossible to give figures which might be reliably applied to every case.

Much depends upon the character of the raw materials, which may be hard or soft. The first cost of the machinery to deal with the softer materials will be less than that of machinery to deal with the harder materials.

Again, the distance apart of the various raw materials may be considerable, necessitating conveying machinery more or less costly.

The question of the supply of water, which is required in large quantities, may considerably affect the first cost.

The supply of fuel—coal is at present generally used in this country—and its cost must have a potent effect on the cost of the finished product.

Then questions of rent, rates, taxes, royalty, insurance, and depreciation have also to be considered.

Labour, again, is a highly important factor, and it is necessary, in order to keep the cost low, that efficient labour-saving machinery should be installed wherever possible.

Management also enters largely into the success or failure of the works, and it behoves those in authority, who have the appointing of the manager, to closely study the qualifications of the candidates.

The manager should have a good all-round engineering knowledge and, above all, a thorough general knowledge of the manufacture of cement.

It is becoming increasingly important to obtain the services of a first-class chemist to control the analytical, testing, and research work of the factory.

Given favourable conditions and a properly designed and well-managed cement works, an exceedingly remunerative return on the capital outlay may be confidently looked for.

COST OF PLANT

The cost of building and equipping a modern Portland Cement plant with rotary kilns requires a heavy investment.

It must be quite understood that local conditions at home or abroad would considerably alter the estimates given in the table below, which are but an approximation with normal prices, including land, working capital, and promotion expenses.

Raw Material.	Annual Output.	Cost per Ton.			Total Capital Outlay.
		Annual Output.			
	Tons.	£	s.	d.	£
Soft	50,000	1	10	0	75,000
Hard	50,000	1	15	0	87,500
Soft	100,000	1	7	6	137,500
Hard	100,000	1	12	6	162,500
Soft	150,000	1	5	0	187,000
Hard	150,000	1	10	0	225,000

Soft materials include chalk, marl, etc.

Hard materials include limestone rock and materials of a similar nature.

(Described on p. 8.)

The approximate real investment in Portland Cement Plants in the United States is \$180,000,000, producing 90,000,000 barrels of cement, the equivalent of \$2.00 per barrel of yearly production.¹

A barrel of cement is 380 lb. net.

Most of the raw materials are of a crystalline nature.

LABOUR COSTS PER TON OF CEMENT—

OUTPUT 3,000 TONS PER WEEK

Assuming conditions are favourable as mentioned under "Design and Construction", the following labour costs in the various departments of the factory may be accepted, although it must be fully understood that local conditions will alter these itemized statements, viz. :—

Formation and position of raw material deposits.

Distance of quarry from crushers.

Cost of labour.

PROCESS WET

Material : Hard Limestone and Clay

A difficult combination where extreme fineness is absolutely necessary for a volume-constant cement direct from the grinding mill.

Capacity

3,000 tons of Portland Cement a week.

¹ From *Rock Products and Building Materials*, November 22, 1913, Chicago, Ill., U.S.A.

Quarrying Limestone and Delivering to Crushers

Foreman	}	Cost per ton of P.C.	d. 3·6
One navy driver			
One wheelsman			
One stoker			
Six trackmen			
Six banksmen			
Two drillers			
Two loco drivers			
Two firemen			
Two switchmen			

Average 60 working hours per week.

Quarrying Clay and Delivering to Washmill

Removing top soil or overburden from limestone and clay deposits, also, when necessary, working the spare steam navy in the limestone quarry which it is desirable to install

One navy driver	}	Cost per ton of P.C.	1·25
One wheelsman			
One fireman			
Four trackmen			
One loco driver			
One fireman			

Average 60 working hours per week.

Crushing Limestone and Preparing Clay for Delivery to Mill

Tippler	}	Cost per ton of P.C.	1·0
Primary crushing			
Secondary crushing			
Crushing rolls			
Conveyors and elevators (six men)			

Clay Washing Mill

Two men	Cost per ton of P.C.	0·28
-------------------	----------------------	------

*Storage of Raw Material at Crushers and Clay Washmill
(Locomotive Crane and Grab)*

One driver	}	Cost per ton of P.C.	0·28
One labourer			

Average 60 working hours per week.

Carried forward 6·41

d.

Brought forward . . . 6.41

Raw Grinding Mill

Two millers	}	Cost per ton on P.C.	1.16
Two oilers			
Two conveyormen			
Two labourers			

Average 120 working hours per week (2 shifts of 12 hours).

Slurry Storage Tanks and Pumps

Three men	Cost per ton of P.C.	0.36
---------------------	------------------------------	------

Average 168 working hours per week (3 shifts of 8 hours).

Rotary Kiln

Three burners	}	Cost per ton of P.C.	1.624
Three oilers			
Three conveyormen (for coal feed hoppers, etc.)			
Three cooler attendants			

Average 168 working hours per week (3 shifts of 8 hours).

Clinker Storage and Grinding Mill

Two millers	}	Cost per ton of P.C.	1.16
Two oilers			
Two conveyormen			
Two general (for clinker store)			

Average 120 working hours per week (2 shifts of 12 hours).

Coal Store, Drying and Grinding Mill

Two millers	}	Cost per ton of P.C.	1.44
Two oilers			
Two elevator and conveyormen			
Two coal dryermen			
Two labourers			

Average 120 working hours per week (2 shifts of 12 hours).

Power Plant

Three engine-drivers	}	Cost per ton of P.C.	2.8
Three pumpmen			
Three switchboard attendants			
Six stokers			
Six coal trimmers			

Average 168 working hours per week (3 shifts of 8 hours).

Carried forward . . . 14.954

	<i>d.</i>
<i>Brought forward . . .</i>	14.954
<i>Engineer Staff</i>	
Foreman fitter	} Cost per ton of P.C. 4.726
Three fitters	
One turner	
Two repairmen	
Two blacksmiths	
One carpenter	
Two wheelwrights	
One bricklayer	
Three electricians	
Three motor attendants	
Twelve labourers	
Average 60 working hours per week.	
<i>Yard Gang</i>	
One ganger	} Cost per ton of P.C. 1.31
Six labourers	
One locomotive driver	
One fireman	
One switchman	
Average 60 working hours per week.	
<i>Storehouse, etc.</i>	
	Cost per ton of P.C.
	<i>d.</i>
Labour	0.35
Building and repairs	0.50
Permanent way	0.50
Filling and loading	7.50
Miscellaneous	1.31
	<hr style="width: 50px; margin-left: auto; margin-right: 0;"/> 10.16
<i>Laboratory</i>	
Salaries	Cost per ton of P.C. 1.2
<i>Superintendence and Office</i>	
Salaries	Cost per ton of P.C. 4.65
	<hr style="width: 50px; margin-left: auto; margin-right: 0;"/>
Total	37.00
<i>Supplies</i>	
	Cost per ton of P.C.
	<i>d.</i>
Powder, fuses, etc.	2.00
Gypsum	3.00
Oil and waste	1.50
Coal (at 14s. per ton)	84.00
	<hr style="width: 50px; margin-left: auto; margin-right: 0;"/>
	90.50
Repairs and renewals	9.00

Total per ton of Cement *d.*

Labour	31.15
Laboratory	1.2
Superintendence and office	4.65
Supplies	99.50

136.5 = 11s. 4½*d.*

CEMENT PRODUCTION AND SHIPMENTS
DURING 1914¹

Figures gathered by United States Geological Survey show decrease in both quantity and value of output.

PORTLAND CEMENT OUTPUT IN THE UNITED STATES IN 1913 AND 1914, BY DISTRICTS, IN BARRELS

	1913.	1914.	Change per cent.	Average factory price per barrel. 1913.	1914.	Change per cent.
<i>Lehigh District (Eastern Pennsylvania and New Jersey).</i>						
Production	27,139,601	24,614,933	- 9.30	\$ —	\$ —	—
Shipments	26,659,537	23,968,554	-10.09	.838	.809	- 3.46
Stock	2,448,400	3,118,958	+27.39	—	—	—
<i>New York State.</i>						
Production	5,208,020	5,886,124	+13.02	—	—	—
Shipments	5,136,334	5,474,191	+ 6.58	.934	.917	- 1.82
Stock	556,557	972,082	+74.66	—	—	—
<i>Ohio and Western Pennsylvania.</i>						
Production	7,690,010	7,592,065	- 1.27	—	—	—
Shipments	7,287,028	7,466,887	+ 2.47	1.000	.876	-12.50
Stock	1,031,892	1,132,140	+ 9.71	—	—	—
<i>Michigan and North-Eastern Indiana.</i>						
Production	5,057,199	5,214,557	+ 3.11	—	—	—
Shipments	4,960,891	5,157,613	+ 3.95	1.030	.960	- 6.80
Stock	643,770	678,980	+ 5.47	—	—	—
<i>Southern Indiana and Kentucky.</i>						
Production	3,005,417	2,930,735	- 2.48	—	—	—
Shipments	2,861,624	2,932,003	+ 2.46	1.008	.717	-28.87
Stock	436,703	435,742	- .22	—	—	—
<i>Illinois and North-Western Indiana.</i>						
Production	12,423,799	11,532,605	- 7.17	—	—	—
Shipments	11,576,938	11,316,645	- 2.25	1.002	.932	- 6.99
Stock	1,924,367	2,135,023	+10.95	—	—	—
<i>Maryland, Virginia, and West Virginia.</i>						
Production	2,668,338	2,784,988	+ 4.37	—	—	—
Shipments	2,529,629	2,793,036	+10.41	.865	.877	+ 1.27
Stock	341,120	332,695	- 2.47	—	—	—
<i>Tennessee, Alabama, and Georgia.</i>						
Production	3,082,623	2,672,210	-13.31	—	—	—
Shipments	2,958,829	2,577,099	-12.90	.899	.935	+ 3.89
Stock	287,300	383,507	+33.48	—	—	—
<i>Iowa and Missouri.</i>						
Production	8,427,012	8,957,613	+ 6.30	—	—	—
Shipments	7,941,620	8,930,465	+12.45	1.074	.940	-11.45
Stock	1,397,847	1,472,728	+ 5.35	—	—	—

¹ From *Rock Products and Building Materials*, June 7, 1915, Chicago, Ill., U.S.A.

	1913.	1914.	Change per cent.	Average factory price per barrel.		Change per cent.
				1913.	1914.	
<i>Nebraska, Kansas, Oklahoma, and Central Texas.</i>						
Production .	6,350,646	6,253,731	- 1.53	\$ —	\$ —	—
Shipments .	6,190,040	6,016,774	- 2.80	1.063	.930	- 12.51
Stock . . .	848,949	1,033,002	+ 21.68	—	—	—
<i>Rocky Mountain States (Colorado, Utah, Montana, Arizona, and Western Texas).</i>						
Production .	2,546,082	2,698,151	+ 5.97	—	—	—
Shipments .	2,545,473	2,754,591	+ 8.21	1.319	1.306	- .99
Stock . . .	246,241	210,577	- 14.48	—	—	—
<i>Pacific Coast States (California and Washington).</i>						
Production .	8,498,384	7,092,458	- 16.54	—	—	—
Shipments .	8,041,434	7,050,098	- 12.33	1.461	1.277	- 12.66
Stock . . .	1,057,182	988,429	- 6.50	—	—	—
<i>Total.</i>						
Production .	92,097,131	88,230,170	- 4.20	—	—	—
Shipments .	88,689,377	86,437,956	- 2.54	1.005	.927	- 7.76
Stock . . .	11,220,328	12,893,863	+ 14.92	—	—	—

One barrel = 380 lb. net.

5.895 barrels = 1 English ton (2,240 lb.).

For 1914—

The lowest average factory price per barrel, Southern Indiana and Kentucky = 17s. 7d. per English ton.

The highest average factory price per barrel, Rocky Mountain States = 32s. 2d. per English ton.

Average factory price per barrel throughout the United States = approximately 23s. per English ton.

SYSTEMATIC COST KEEPING

To attain high efficiency in managing a Portland Cement plant unit cost records and reports are essential.

Without cost keeping no enterprise can exist, and it behoves cement manufacturers to search for and adopt methods which have proved efficient and successful.

The use of scientific cost keeping will often expose a weak spot in mill operations; it also stimulates the search for better methods of production with their consequent reduction of cost.

The history of all industries corroborates the fact that lowering the cost means the finding of a larger number of uses for the product.

In these days of increase in the values of labour and materials—and the prospect is that they will continue to increase—it certainly is incumbent on those who utilize these two elements to be satisfied they are used to the best advantage and in combination have lost no more than they should.

It is not enough for a manager of a cement plant to know that he is producing cement at a certain cost; he should know

whether or not every section of the factory is being carried out on a paying basis.

By a weekly analysis of wages and stores a manager can determine very quickly if it is desirable to concentrate his efforts on a particular section of the factory.

The daily reports from all departments is the starting-point of cost keeping and economical production. The running hours of every machine are daily tabulated and their efficiency proved.

The moral effect on the men themselves in recording the day's run and output is a justification of keeping records; it is a natural instinct of men to excel in their undertakings, and in order to get the best out of them their interest in their work must be aroused, and they must be impressed with a sense of their responsibility; and there is no better way of creating this friendly competition than each shift recording their respective records done by their machines.

There is no man, no matter how lowly he may be, or whatever may be the nature of his work, whose interest cannot be aroused by impressing him with a sense of his responsibility, and showing him wherein the competition lies in connection with his work.

Therefore, anything that can be done to arouse the interest of the men in their work and bring about friendly competition is of inestimable value, and nothing will do more to produce results than recording on the daily report sheets the hours their machine has been running and quantity of material turned out.

Sometimes the impression prevails that the necessary job orders, time-sheets, daily reports, material reports, and progress reports which the foreman has to deal with are apt to confuse him, and consequently decrease rather than increase the efficiency of his work. Experience has proven otherwise; they tend to develop and awaken the interest of the foreman.

He realizes that he is an important factor in the organization; he is also alive to the fact that his reports will be checked by the final weighing of the cement whilst being shipped. This puts him on his mettle, increases his attention generally, and his value as a supervisor.

Unit cost records and reports are invaluable guides in the conduct of a Portland Cement works, and must not be underestimated by secretaries or managers who wish to carry out their work in an efficient and economical manner.

The wages of all employees are analysed and allocated to each department and machine.

Stores are dealt with in a similar manner, and detection of abnormal demand is at once apparent.

Comparative cost-sheet is to be recommended, which gives at a glance the reason of an increase or decrease of the cost per ton of cement month by month.

Daily Report
LIMESTONE QUARRY

.....191.....

	Hours on.	Hours off.	Cause of Delay, and Remarks.
Steam navy . . .			
Limestone loaded . . .	Tons.		
Limestone to crushers . . .			
Limestone to store . . .			
Steam drill . . .	Hours on.	Hours off.	
Depth of holes drilled . . .	Feet.	Inches.	

Foreman.....

TO BE IN MANAGER'S OFFICE BY 10 A.M.

Daily Report
CRUSHING DEPARTMENT

.....191.....

	Hours on.	Hours off.	Cause of Delay, and Remarks.
Primary crusher . . .			
Secondary ,, . . .			
Crushing rolls . . .			
Rotary screen . . .			
Elevators . . .			
Conveyors . . .			
Limestone from quarry.			
,, ,, store . . .			
Locomotive crane . . .			
Clay washmill . . .			

Attendant.....

Foreman.....

TO BE IN MANAGER'S OFFICE BY 10 A.M.

Daily Report
CLAY OR SHALE QUARRY

.....191.....

	Hours on.	Hours off.	Cause of Delay, and Remarks.
Steam navvy . . .			
Clay or shale loaded . . .	Tons.		
To washmill . . .			
To store . . .			

Foreman.....

TO BE IN MANAGER'S OFFICE BY 10 A.M.

Daily Report
WET GRINDING MILL

Day or Night Shift.....191.....

	Hours on.	Hours off.	Fineness of Finished Material.	Cause of Delay, and Remarks.
No. 1 ball mill . . .				
„ 2 „ . . .				
„ 3 „ . . .				
„ 4 „ . . .				
„ 1 tube mill . . .				
„ 2 „ . . .				
„ 3 „ . . .				
„ 4 „ . . .				
Conveyors . . .				
Elevators .. .				

Miller.....

Foreman.....

TO BE IN MANAGER'S OFFICE BY 10 A.M.

Daily Report

SLURRY STORAGE DEPARTMENT

Day or Night Shift.....191.....

	Hours on.	Hours off.	Stock of Slurry.	Cause of Delay, and Remarks.
No. 1 mixer . . .				
„ 2 „ . . .				
„ 3 „ . . .				
„ 4 „ . . .				
„ 1 slurry pump			Clay Mixture	
„ 2 „ . . .				
„ 3 „ . . .				
„ 4 clay pump .				
„ 5 „ . . .				

Pump Attendant.....

Foreman.....

TO BE IN MANAGER'S OFFICE BY 10 A.M.

Daily Report

ROTARY KILN DEPARTMENT

Day or Night Shift.....191.....

	Hours on.	Hours off.	Cause of Delay, and Remarks.
No. 1 kiln			
„ 2 „			
„ 3 „			
„ 1 cooler			
„ 2 „			
„ 3 „			
Slurry feed			
Elevators			
Conveyors			
Coal feed screws			

	Tons.	Cwt.	Stock of Ground Coal.	Tons.	Cwt.	
Ground coal used			No. 1 hopper			
Clinker made			„ 2 „			
			„ 3 „			

Burner

Foreman

TO BE IN MANAGER'S OFFICE BY 10 A.M.

Daily Report

COAL GRINDING DEPARTMENT

Day or Night Shift *191*

	Hours on.	Hours off.	Cause of Delay, and Remarks.
No. 1 ball mill . . .			
" 2 " . . .			
" 3 " . . .			
" 1 tube mill . . .			
" 2 " . . .			
" 3 " . . .			
Elevators . . .			
Conveyors . . .			
Coal dryer . . .			
Coal crusher . . .			
Coal on stock . . .	Tons.	Cwt.	
Quantity ground . . .			

Miller

Foreman

TO BE IN MANAGER'S OFFICE BY 10 A.M.

Daily Report

CEMENT GRINDING MILL

Day or Night Shift..... 191.....

	Hrs. on.	Hrs. off.	Fineness of Finished Cement.	No. of Silo conveyed to.	Cause of Delay, and Remarks.
No. 1 ball tube mill					
" 2 " "					
" 3 " "					
" 4 " "					
" 1 tube mill .					
" 2 " .					
" 3 " .					
" 4 " .					
Elevators . .					
Conveyors . .					
Quantity ground .	Tons.	Cwt.			

Miller.....

Foreman.....

TO BE IN MANAGER'S OFFICE BY 10 A.M.

Daily Report

BOILER HOUSE

Day or Night Shift..... 191.....

	Hours on.	Hours off.	Cause of Delay, and Remarks.
No. 1 boiler . . .			
„ 2 „ . . .			
„ 3 „ . . .			
„ 4 „ . . .			
„ 5 „ . . .			
„ 6 „ . . .			
Boiler feed pump, No. 1			
„ „ „ No. 2			
Economizer . . .			
Elevators . . .			
Coal used . . .	Tons.	Cwt.	
Stock of coal in bunkers			

Stoker.....

Engineer.....

TO BE IN MANAGER'S OFFICE BY 10 A.M.

Daily Report

POWER-HOUSE

Day or Night Shift.....191.....

	Hours on.	Hours off.	Cause of Delay, and Remarks.
No. 1 engine . . .			
„ 2 „ . . .			
„ 3 „ . . .			
„ 4 „ . . .			
„ 1 condenser . . .			
„ 2 „ . . .			
„ 3 „ . . .			
„ 4 „ . . .			
„ 1 circulating pumps			
„ 2 „ „			
„ 3 „ „			
„ 4 „ „			

Attendant.....

Engineer.....

TO BE IN MANAGER'S OFFICE BY 10 A.M.

Daily Cooperage Return

.....191.....

	Number.	Order No.
Barrels available for issue		
Sizes and description		
„ manufactured (previous day)		
Sizes and description		
„ in progress of manufacture		
Sizes and description		

Foreman.....

TO BE IN MANAGER'S OFFICE BY 10 A.M.

Daily Sack Return

Date 191

Number

Sacks available for issue { New
 Previously used
 Total

Sacks repaired
 ,, to be repaired
 ,, dried, cleaned, and sorted
 ,, found useless
 ,, received (previous day)
 From whom—
 A
 B
 C
 D

Foreman

TO BE IN MANAGER'S OFFICE BY 10 A.M.

Daily Report

STEEL DRUM PLANT

..... 191

	Number.	Order No.
Drums available for issue		
Sizes and description		
,, manufactured (previous day)		
Sizes and description		
,, in progress of manufacture		
Sizes and description		

Foreman

TO BE IN MANAGER'S OFFICE BY 10 A.M.

Wages Analysis Sheets

QUARRY LIMESTONE

Week ending 191.....

Names.	Rolling Stock.			Locomotive.			Steam Shovel.			Drill.			Coal.			Explosives.			TOTAL.		
	£	s.	d.	£	s.	d.	£	s.	d.	£	s.	d.	£	s.	d.	£	s.	d.	£	s.	d.
W. Smith							2	10	0												

QUARRY CLAY

Names.	Rolling Stock.			Locomotive.			Steam Shovel.			Drill.			Coal.			Explosives.			TOTAL.		
	£	s.	d.	£	s.	d.	£	s.	d.	£	s.	d.	£	s.	d.	£	s.	d.	£	s.	d.

RAW GRINDING MILLS

Names.	Crushers.			Raw Mill Silo.			Ball Tube Mills.			Tube Mills.			Elevators.			Motors.			TOTAL.		
	£	s.	d.	£	s.	d.	£	s.	d.	£	s.	d.	£	s.	d.	£	s.	d.	£	s.	d.

SLURRY TANKS

Names.	Mixers.			Pumps.			Motors.			TOTAL.		
	£	s.	d.	£	s.	d.	£	s.	d.	£	s.	d.

COOPERAGE

Names.	Cask-making.			Staves.			Machinery.			Motors.			TOTAL.		
	£	s.	d.	£	s.	d.	£	s.	d.	£	s.	d.	£	s.	d.

STEEL DRUMS

Names.	Making.			Machinery.			Motors.			TOTAL.		
	£	s.	d.	£	s.	d.	£	s.	d.	£	s.	d.

SACK STORE

Names.	Checking.		Drying.		Cleaning.		Mending.		Machinery.		Motors.		TOTAL.					
	£	s.	d.	£	s.	d.	£	s.	d.	£	s.	d.	£	s.	d.	£	s.	d.

POWER-HOUSE

Names.	Boilers.			Turbo-Generators.			Switchboard.			Pumps.			TOTAL.		
	£	s.	d.	£	s.	d.	£	s.	d.	£	s.	d.	£	s.	d.

102 THE PORTLAND CEMENT INDUSTRY

Names.	Buildings.			Per- manent Way.			Loco- motive.			Rolling Stock.			Fire Goods.			Light- ing.			Water Supply.			New Work.			Stables.			TOTAL.																	
	£	s.	d.	£	s.	d.	£	s.	d.	£	s.	d.	£	s.	d.	£	s.	d.	£	s.	d.	£	s.	d.	£	s.	d.																		

Names.	Estate Repairs.			Laboratory.			General Office.			General Charges.			TOTAL.																										
	£	s.	d.	£	s.	d.	£	s.	d.	£	s.	d.	£	s.	d.																								

GRAND TOTAL : £ s. d.

Stores Analysis Sheet (continued)

Department.	Dates.															Department Totals.		
	Week ending Jan. 1.			Week ending Jan. 8.			Week ending Jan. 15.			Week ending Jan. 22.			Week ending Jan. 29.					
	£	s.	d.	£	s.	d.	£	s.	d.	£	s.	d.	£	s.	d.	£	s.	d.
Weekly totals . . .																		
Rolling stock																		
Fire goods																		
Lighting																		
Water supply																		
New work																		
Exceptional repairs . . .																		
Stables																		
Estate repairs																		
General charges																		
Coal for burning																		
Coal for power																		
Gypsum																		
Weekly totals . . .																		

Cost Sheet

Department.	Month.....						Month.....						Department Totals.		
	Labour.		Supplies.		Total.		Labour.		Supplies.		Total.				
	£	s.	d.	£	s.	d.	£	s.	d.	£	s.	d.	£	s.	d.
Quarry (limestone)—															
Rolling stock															
Locomotives															
Steam shovel															
Coal															
Drilling															
Explosives															
Lubricants															
Quarry (clay)—															
Rolling stock															
Locomotives															
Steam shovel															
Coal															
Drilling															
Explosives															
Lubricants															
Monthly totals . . .															

Cost Sheet (continued)

Department.	Month.....						Month.....						Department Totals.		
	Labour.		Supplies.		Total.		Labour.		Supplies.		Total.				
	£	s.	d.	£	s.	d.	£	s.	d.	£	s.	d.	£	s.	d.
Monthly totals . . .															
<i>Raw grinding mills—</i>															
Crushers															
Raw mill silo															
Grit mills															
Finishing mills															
Elevators															
Conveyors															
Motors															
Lubricants															
<i>Slurry tanks—</i>															
Mixers															
Pumps															
Motors															
Lubricants															
<i>Coal grinding mills—</i>															
Ball mills															
Tube mills															
Elevators															
Conveyors															
Coal dryers															
Motors															
Lubricants															
<i>Rotary kilns—</i>															
Rotary kilns															
Coolers															
Coal feeds															
Slurry feeds															
Motors															
Lubricants															
<i>Clinker grinding mills—</i>															
Grit mills															
Finishing mills															
Elevators															
Conveyors															
Motors															
Lubricants															
<i>Cement warehouse—</i>															
Elevators															
Conveyors															
Filling and loading															
Motors															
Lubricants															
Monthly totals . . .															

Cost Sheet (continued)

Department.	Month.....						Month.....						Department Totals.		
	Labour.		Supplies.		Total.		Labour.		Supplies.		Total.				
	£	s. d.	£	s. d.	£	s. d.	£	s. d.	£	s. d.	£	s. d.	£	s. d.	
Monthly totals . . .															
<i>Cooperage—</i>															
Cask-making															
Staves															
Machines															
Motors															
Lubricants															
<i>Steel drums—</i>															
Making															
Machinery															
Motors															
Lubricants															
<i>Sack store—</i>															
Checking															
Drying															
Cleaning															
Mending															
Machinery															
Motors															
Lubricants															
<i>Power-house—</i>															
Boilers															
Turbo-generators															
Switchboard															
Pumps															
Lubricants															
<i>Buildings</i>															
<i>Permanent way</i>															
<i>Locomotives</i>															
<i>Rolling stock</i>															
<i>Fire goods</i>															
<i>Lighting</i>															
<i>Water supply</i>															
<i>New work</i>															
<i>Exceptional repairs</i>															
<i>Stables</i>															
<i>Estate repairs</i>															
<i>General charges</i>															
Monthly totals . . .															

Cost Sheet (continued)

Department.	Month.....						Month.....						Department Totals.		
	Labour.		Supplies.		Total.		Labour.		Supplies.		Total.				
	£	s. d.	£	s. d.	£	s. d.	£	s. d.	£	s. d.	£	s. d.			
Monthly totals															
Coal for burning															
Coal for power															
Gypsum															
Administrative—															
a. General office															
b. Laboratory															
Fixed charges—															
a. Interest, cost of works															
b. Value of raw ma- terial used															
c. Insurance and taxes															
d. Depreciation of factory and ma- chinery															
e. Sinking fund															
f. Royalty															
g. Directors															
h. Selling charges															
Monthly totals															
Cost per ton															

CHAPTER X

EQUIPMENT

MECHANICAL EQUIPMENT OF SOME MODERN PORT- LAND CEMENT PLANTS ERECTED DURING THE LAST FIVE YEARS

NO. 1 PLANT

PROCESS WET

Material : Chalk and clay

Weekly Capacity : 3,000 tons.

Chalk Quarry

Steam navy capacity 80 tons per hour.

Clay Quarry

Steam navy capacity 40 tons per hour—three locomotive engines and 6 cubic yard capacity side-tipping cars. Chalk quarry $1\frac{1}{2}$ miles from the washmill ; clay quarry half a mile from the washmill.

Grinding the Raw Materials

Washmill (coarse gratings).

Washmills (fine gratings).

Two tube mills (6 × 26 feet).

Three sets of three-throw ram pumps.

Average running hours 65 per week full capacity.

Slurry Storage and Mixing

Three circular storage tanks 66 feet diameter × 10 feet deep.

Three sets of three-throw ram pumps.

Rotary Kilns for Burning

Three rotary kilns (9 feet diameter × 200 feet long).

Three rotary coolers (6 feet diameter × 80 feet long).

Average running time 50 full weeks per year, allowing each kiln off two weeks during the year for relining in firing zone and minor repairs and adjustments.

Coal Crushing, Drying, and Grinding

One crusher.

One dryer (5 feet diameter × 60 feet long).

Eight Griffin mills.

Average running time 120 hours per week.

Grinding the Clinker

Eight ball mills (No. 8).

Eight tube mills (5 ft. 6 in. diameter \times 27 ft. long).

Average running time 120 hours per week.

Cement Storage

Low frame buildings divided into bins by timber partitions.
Capacity 15,000 tons. Packing, hand labour.

Cooperage

Stave Department	{	Four multiple stave jointers. Four stave tonguing and grooving machines. Two stave chiming, crozing, and printing machines. Two 80 ft. stave heating stoves.
Trussing Department	{	Eight adjustable trussing bells for different sizes of barrels.
Heading Department	{	Four head rounding machines. Three treadle head compressors. One circular saw. Two tonguing, grooving, and thickening machines.
Iron Department	{	Four hoop riveting machines. Four hoop splaying machines. Three multiple hoop punching and shearing machines.
Hydraulic Plant	{	Two accumulators. Four sets pumps.
Machine Shop	{	One circular saw sharpener. One automatic cutter grinding machine.

Power required: 70 to 80 horse-power.

Average running hours 60 per week. Output 12,000 barrels.

Sack Department

Sack storage capacity for 200,000 sacks.

One sack-cleaning machine.

Drying apparatus.

Two sewing and darning machines.

Power Plant

2,500 horse-power.
 Three compound engines.
 One 1,500 h.p.
 Two 500 h.p. each.
 Eight Lancashire boilers.

Note.—The apparent large boiler capacity is due to the arrangement of the works, three separate power plants being laid down, each having one engine, viz. :—

One 500 h.p. engine for raw grinding with two boilers.
 One 1,500 h.p. engine for cement grinding with four boilers.
 One 500 h.p. engine for kilns and auxiliary machinery with two boilers.

NO. 2 PLANT

PROCESS WET

Materials : Argillaceous limestone and shale.
Weekly Capacity : 3,000 tons.

Quarry

(Limestone and shale interstratified.)
 Steam navy capacity 80 tons per hour.

Churn Drill

Two locomotive engines.
 10 cubic yard capacity side-tipping cars.
 Quarry 800 yards from crushers.
 Average running time 70 hours per week.

Crushing the Raw Material

One rotary screen (extracting excess shale).
 One jaw crusher, feed opening 54 × 36 in.
 Two No. 6 gyratory crushers.
 Crushing rolls.
 Average running time 70 hours per week.

Drying, Grinding, and Mixing the Raw Material

Three rotary dryers (7 feet diameter × 80 feet long).
 Twelve 40 in. giant Griffin mills.

Mixing Mill

Product from Griffin mills now made into a slurry.
 Average running time 120 hours per week.

Slurry Storing and Mixing

Two circular tanks 66 feet diameter \times 10 feet deep for slurry.
 One ditto for clay mixture.
 Three sets of three-throw ram pumps (two sets for slurry, one set for clay mixture).

Rotary Kilns for Burning

Three rotary kilns (10 feet diameter \times 175 feet long).
 Three rotary coolers (7 feet diameter \times 60 feet long).

Coal Crushing, Drying, and Grinding

One crusher.
 One dryer (5 feet diameter \times 60 feet long).
 Eight 30 in. Griffin mills.
 Average running time 120 hours per week.

Grinding the Clinker

Twelve 40 in. giant Griffin mills.
 Average running time 120 hours per week.

Cement Storage

Low frame buildings divided into bins by timber partitions.
 Capacity 10,000 tons. Packing, automatic (Bates' valve bag system).

Bag Department

Storage capacity 500,000 bags (95 lb.).
 One bag-cleaning machine.
 Drying apparatus.
 Two sewing and darning machines.

Power Plant

Four 600 h.p. water tube boilers.
 Two 2,000 kw. Curtis steam turbines.

Machine Shop

Smithy; fitting shop; carpenter's and wheelwright's shop.

NO. 3 PLANT

PROCESS DRY

Material : Limestone and clay.
Weekly Capacity : 1,500 tons.

Limestone Quarry

One steam shovel, capacity 40 tons per hour.
 One big blast hole drill.
 Side dump cars, capacity 6 tons.
 Locomotive engine.

Clay Quarry

- Locomotive crane and grab.
- Side dump cars.
- Locomotive engine.
- Limestone (for preparatory treatment) :
 - One primary crusher (gyratory), capacity 60 tons per hour.
 - One rotary screen 2 in. mesh.
 - One secondary crusher, capacity 40 tons per hour.
 - Crushing rolls.
 - Elevating conveying machinery.

Drying Department

- Rotary dryer for limestone, 7 × 80 feet.
- One rotary dryer for clay, 6 × 60 feet.

Grinding and Mixing

- One disintegrator for clay.
- Eight Fuller-Lehigh mills for limestone.
- Richardson's automatic scales.

Rotary Kilns Department

- Four rotary kilns, 7 ft. 6 in. × 125 feet long.
- Four rotary coolers, 5 feet diameter × 60 feet long.

Clinker Grinding Mill

- Eight Fuller-Lehigh mills.
- Elevating and conveying machinery.
- Gypsum crusher with elevator to hopper over clinker.
- Conveyor with automatic feeder.

Crude Oil, Storage and Pump House

- Two sets of three-throw oil pumps.
- Pipe system to rotary kilns, dryers, boilers, etc., boilers for raising steam to heat the oil.
- Two air compressors, working pressure 80 lb. per square inch, for atomizing and feeding crude oil to the kilns, dryers, and boilers.

Power

- Electrical (supplied by an outside source).

Bag Department

- One bag-cleaning machine.
- One drying apparatus.
- One sewing and darning machine.

NO. 4 PLANT.

(Provision made to double capacity.)

PROCESS WET

Material : Limestone and clay.*Weekly Capacity* : 1,200 tons.*Limestone Quarry*

Steam shovel, capacity 80 tons per hour.

Big blast hole drill.

Side dump cars.

Locomotive engine.

Clay Quarry

Steam shovel.

Side dump cars.

Locomotive engine.

Limestone (for preparatory treatment) :

One primary crusher.

One secondary crusher.

Crushing rolls ($\frac{3}{4}$ in. mesh).

Clay (for preparatory treatment) :

Washmill.

Pumps.

Raw Material Store for Limestone and Clay

Locomotive crane and crab.

*Raw Grinding Mill*Two kominuters (8 feet diameter \times 8 feet long).Two tube mills (6 feet diameter \times 22 feet long).

Two slurry pumps.

*Mixing and Storage Tanks*Two tanks (66 feet diameter \times 10 feet deep), for finished slurry.

One tank for clay mixture.

Two slurry pumps (to supply rotary kiln).

Two pumps for clay water (to supply kominuters).

*Rotary Kiln Department*One rotary kiln (9 feet diameter \times 220 feet long).One cooler (6 feet diameter \times 80 feet long).

Clinker elevating and conveying machinery.

*Clinker Grinding Mill*Two kominuters (8 feet diameter \times 8 feet long).Two tube mills (6 feet diameter \times 22 feet long).

Elevating and conveying machinery.

Gypsum Store

One crusher capacity, 5 tons per hour.
 Elevating and conveying machinery.
 Automatic feeder to clinker with positive regulator.

Cement Storage

Capacity 12,000 tons.

Sack Department

One dryer.
 One cleaning machine.
 Two sewing and darning machines.
 Storage capacity 500,000 sacks, 95 lb. capacity.

Crude Oil Storage and Pump House

Storage tank, 15,000 barrels of crude oil.
 Two sets of three-throw oil pumps.
 Pipe system to rotary kilns, boilers.
 Two air compressors. Working pressure 80 lb. per square inch
 for rotary kilns and boiler feeds.

Power Plant

Diesel engine-power plant directly connected to generators.
 Two 750 b.h.p. engines.

NO. 5 PLANT

PROCESS WET

Material : Argillaceous limestone and shale (interstratified).
Weekly Capacity : 1,200 tons.

Quarry

Steam Navvy Capacity : 60 tons per hour.
 One locomotive engine.
 Eight yard side-tipping cars.
 Average running hours 50 per week, full capacity.

Crushing Raw Material

Tippler.
 Automatic feeding apparatus screening the excess shale during
 its passage to the crusher.
 One jaw crusher, capacity 60 tons per hour.
 Crushing rolls: capacity 60 tons per hour.
 Raw material storage, 5,000 tons capacity.
 Well-arranged system of belt elevating and conveying machinery,
 avoiding manual labour.
 Average running hours 50 per week, full capacity.

Grinding the Raw Materials

Two combined ball and tube mills (solo mill).

Two sets of three-throw ram pumps.

Average running hours 120 per week, full capacity.

Slurry Storage and Mixing

Two circular storage tanks (66 feet diameter \times 10 feet deep).

Two sets of three-throw ram pumps.

Rotary Kiln and Coolers

One rotary kiln (9 feet diameter \times 200 feet long).

One cooler (6 feet diameter \times 80 feet long).

One set coal feed screws.

One fan supplying coal dust to kiln.

Average running time 50 full weeks per year, allowing kiln off two weeks during the year for relining in firing zone and minor repairs and adjustments.

Clinker Store (Covered)

Capacity 5,000 tons.

Well-arranged system of automatic handling.

Coal Crushing, Drying, and Grinding

One crusher.

One dryer (5 feet diameter \times 60 feet long).

One compound ball and tube mill.

Average running time 120 hours per week.

Grinding the Clinker

Two combined ball and tube mills.

Average running time 120 hours per week.

Cement Storage

Low frame buildings, divided into bins by timber partitions.

Capacity 5,000 tons. Packing, automatic.

Cooperage

Output 6,000 barrels.

Average running hours 60 per week.

Power Plant

Machinery electrically driven.

Two slow-speed, drop-valve, horizontal steam-engines with fly-wheel generators on crankshaft, each 500 kw. capacity; total power 1,000 kw., or 1,600 i.h.p.

Four Lancashire boilers (8 ft. 6 in. diameter \times 30 feet long).

PHYSICAL TESTING

CHAPTER XI

DEVELOPMENT OF CEMENT TESTING

It is not sufficiently realized that cement testing is a highly skilled work, requiring a great deal of experience before one can manipulate the materials so as to obtain even approximate results, and no amount of experience can eliminate the variations introduced by the personal equation which enters into it so largely that it is virtually impossible to obtain tests, made by two or more persons, even under practically identical conditions, which would show the same results.

In the more important tests, where the cement powder is made into a paste, changing completely the physical and chemical properties of the material, very great care is necessary to produce true results.

It is hoped these few notes will be of some assistance to those making occasional tests who would avoid annoyance and disappointment.

DEVELOPMENT OF CEMENT TESTING

Smeaton's.—In 1756 Mr. John Smeaton's first tests were made by forming small balls of the material, placing them under water, and observing their hydraulic properties.

In 1830 Major-General Sir C. W. Pasley, R.E., Lecturer on Architecture, etc., at the Military School of Engineering, Chatham, became interested in cement manufacture, and conducted a crude strength test by cementing bricks against a wall, one at a time, the second being cemented to the first, and so on, the bricks forming a projecting beam, and the cement holding the greatest number of bricks being adjudged the superior.

General Pasley's next test was more scientific in its character, and consisted in cementing together two bricks on end and determining the weight necessary to pull them apart. This appears to have been the origin of the tensile strength test.

Vicat, in 1828, devised an apparatus for determining the hardening of cement. A modification of this apparatus, known as the Vicat needle, is the present standard for testing the time of setting.

In 1858 the late Mr. John Grant, C.E., when making tests of cement in connexion with the construction of the London

main drainage works, was the first to put them upon a scientific basis ; at this time he was the recognized authority on cement.

In 1877 the representatives of the German cement industry formed an association of cement manufacturers to further all interests of the Portland Cement industry, and contributing by scientific work to the knowledge of the properties of Portland Cement. Great progress resulted for the cement industry, as the users of cement were thereby enabled to test and work the cement in a proper manner, and to judge the quality correctly.

Mr. J. P. Griffith, C.E., in 1889 and 1893, read papers to the Institution of Civil Engineers of Ireland, advocating standard tests of cement.¹ This advocacy probably found fruition in the British Standard Specification for Portland Cement.

In 1904 the first publication took place of the British Standard Specification for Portland Cement, through the initiative of Sir John Wolfe Barry, and with the able co-operation of Sir William Mathews and other members of the Institution of Civil Engineers and of various other Engineering Societies.²

In 1903 and 1904 special committees were appointed by the American Society of Civil Engineers, the American Railway Engineering and Maintenance of Way Association, and the Association of American Portland Cement Manufacturers, for the purpose of investigating current practice and providing definite information concerning the properties of concrete and reinforced concrete, which included the testing of Portland Cement.

This scientific system of standardization has wrought a great improvement in the quality of Portland Cement manufactured throughout the world.

GENERAL NOTES ON GAUGING CEMENT

In carrying out tests for tensile (neat and sand) setting time and soundness, the sample submitted must be spread out to a depth of 3 inches for twenty-four hours in a temperature of from 58° to 64° F.³

Fresh water must be used for gauging. Various automatic mixing machines are on the market, but the gauging of test specimens can be satisfactorily accomplished by hand after adequate practice.

Great care should be taken that cement when gauged is not placed on wood or other absorbent material, as this will abstract the water necessary for crystallization.

¹ Trans. Inst. C.E. Ireland, vol. xx, p. 26, and vol. xxii, p. 98.

² This was followed by a second revision issued in August, 1910, and a third revision in March, 1915.

³ The temperatures stated are applicable to temperate climates. In other climates special arrangements between vendor and purchaser must be made, unless the temperature therein stated can be artificially obtained in the laboratory or other place where the tests are made.

All gauging should be done on a slab of marble, slate, or other non-absorbent material.

See that the apparatus and tools used are thoroughly clean before gauging is begun.

The use of the metric system of weights and measures is recommended as being more convenient, and on p. 122 will be found a comparative table giving English weights and measures with metric equivalents.

One cubic centimetre of water is equivalent to one gramme of cement.

To add the water to the cement, form a crater in the top of the heap on the slab and pour the water therein—the crater edges can then be tipped in with the trowel, and the cement will rapidly absorb the water.

The temperature of the air in the room where the tests are being made should be kept between 58° and 64° F. In order to check this an ordinary Fahrenheit thermometer should be placed on the bench or wall.

The quantities of cement and sand should always be taken by weight and not by measure.

The gauging must be completed before the initial set takes place. This point should be specially watched when a quick-setting cement is under test.

The method generally adopted is without doubt convenient for practical testing, but as a matter of interest the following table is given, showing the true percentages for different quantities of added water :—

Cubic centimetres of water, added to 100 grammes cement or cement and aggregate.	Actual percentage of water in total bulk of cement or concrete when gauged.
7	6.54
8	7.41
9	8.26
10	9.09
11	9.91
12	10.71
13	11.50
14	12.28
15	13.04
16	13.79
17	14.53
18	15.25
19	15.97
20	16.67
21	17.36
22	18.03
23	18.70
24	19.35

The usual method of expressing the percentages of gauging water used is not strictly accurate ; for instance, to 100 grammes of cement is added, say, 20 c.c. of water. This is expressed as "20 per cent of water". It will be seen, however, that of the total mixture of 120 parts only 20 parts are water, i.e. 16.67 per cent.

TESTS OF CEMENT REQUIRED FOR IMMEDIATE USE

Questions are often asked as to how an engineer or clerk of works can quickly form a fairly accurate opinion as to the quality of cement required for immediate use. The answer is, that particular attention should be given to three points :—

1. Immediately on receipt of the cement on the work it should be tested for fineness ; this is purely a mechanical operation, and the information on this point can be obtained in a few minutes.

2. It should then be tested for setting time, following the lines described on pp. 139 seqq. to obtain accurate information as to the period of time in which the cement delivered to the works would set.

3. One or more pats should be submitted, twenty-four hours after being made, to a hot-water test, being first placed in any convenient receptacle in cold water, after which the water should be gradually brought up to a temperature of 180° F. or thereabouts and maintained at that temperature for three or four hours.

If the cement prove sound under these conditions it would be sure to give reliable results in the work. These three points being established, special attention should be given to the quality and condition of the material which would be mixed with the cement, as it frequently happens that faulty work is due rather to the aggregate than to the cement. Although somewhat of a departure from the subject, the fact should be emphasized that the cement is only one of several materials, and forms only a small proportion of the finished product, and the durability and strength of the concrete depends, not on the cement alone, but on the character of the aggregate, the proportioning of the same, and the workmanship in mixing and placing the material.

In cases where it is impossible for any reason to carry out these tests in a proper and systematic manner (or where the usual appliances for testing are not available), they may be made in a rough and ready manner, as follows :—

The fineness of the cement may be judged by rubbing a pinch of it between the thumb and finger, and a too coarsely ground cement will in this way easily be detected.

The setting time may be noted by pressing the thumb-nail on a pat, when it will easily be seen whether the cement is quick or slow setting in relation to what is required for the

special work in hand. The cement may be considered set when hard pressure with the thumb-nail makes only a slight impression.

COMPARATIVE TABLE OF ENGLISH WITH METRICAL STRESSES

Kilos per sq. cm.	lb. per sq. in.	Tons per sq. ft.
0.07 equals	1 or	0.06
0.14 "	2 "	0.13
0.21 "	3 "	0.19
0.28 "	4 "	0.26
0.35 "	5 "	0.32
0.42 "	6 "	0.39
0.49 "	7 "	0.45
0.56 "	8 "	0.51
0.63 "	9 "	0.58
0.70 "	10 "	0.64
1.41 "	20 "	1.29
2.11 "	30 "	1.93
2.81 "	40 "	2.57
3.52 "	50 "	3.21
4.22 "	60 "	3.86
4.92 "	70 "	4.50
5.62 "	80 "	5.14
6.33 "	90 "	5.79
7.03 "	100 "	6.43
14.06 "	200 "	12.86
21.10 "	300 "	19.29
28.13 "	400 "	25.71
35.16 "	500 "	32.14
42.19 "	600 "	38.57
49.23 "	700 "	45.00
56.26 "	800 "	51.43
63.29 "	900 "	57.86
70.32 "	1,000 "	64.29
140.65 "	2,000 "	128.57
210.97 "	3,000 "	192.86
281.29 "	4,000 "	257.14
351.62 "	5,000 "	321.43
421.94 "	6,000 "	385.71
492.26 "	7,000 "	450.00
562.59 "	8,000 "	514.29
632.91 "	9,000 "	578.57
703.23 "	10,000 "	642.86

When hard set, let the pat, together with the piece of material upon which it was gauged, be placed in a saucepan (preferably enamelled) in cold water, which should be brought slowly to a temperature a little below boiling, say 180° F. or thereabouts, at which it should be kept for three or four hours. If the cement be sound in these conditions, it may safely be used at once, and will give reliable results in the work.

COMPARATIVE TABLE OF ENGLISH AND METRIC MEASURES

	Inches and Decimals of an inch.
1 millimetre	0·039370
1 centimetre	0·393704
1 decimetre	3·937043
1 metre	39·370432

COMPARATIVE TABLE OF ENGLISH AND METRIC WEIGHTS

	English Pounds.
1 milligram	0·000022
1 centigram	0·000220
1 decigram	0·002204
1 gram	0·0022046
1 decagram	0·220462
1 hectogram	22·04621
1 kilogram	22046212

CHAPTER XII

CHEMICAL COMPOSITION

BRITISH STANDARD SPECIFICATION

Summary

	Not to exceed
Insoluble residue	1·5 per cent
Magnesia	3 „
Total sulphuric anhydride (S O ₃)	2·75 „
Total loss on ignition	3 „

Lime: the proportion of lime to silica and alumina shall not be greater than the maximum nor less than the minimum ratio (calculated in chemical equivalents) represented by

$$\frac{C_a O}{Si O_2 + Al_2 O_3} = 2\cdot85 \text{ or } 2\cdot0 \text{ respectively.}$$

No attempt to determine the composition of Portland Cement should be made by any one not qualified in analytical chemistry. The layman may, however, determine the proportion of lime to silica and alumina in any given analysis of cement by means of the formula in the British Standard Specification, which is calculated as follows:—

In case of cement containing 63·28 per cent of lime, 21·6 per cent of silica, and 8·16 per cent of alumina, the proportion of lime to silica and alumina would be as follows:—

Molecular weight of lime	= 56
„ „ silica	= 60
„ „ alumina	= 102
Lime (C _a O) = $\frac{63\cdot28}{56}$	= 1·13
Silica (Si O ₂) = $\frac{21\cdot6}{60}$	= 0·36
Alumina (Al ₂ O ₃) = $\frac{8\cdot16}{102}$	= 0·08

$$\text{Then } \frac{C_a}{Si O_2 + Al_2 O_3} = \frac{1\cdot13}{0\cdot36 + 0\cdot08} = 2\cdot57.^1$$

It should be noted here that in cases where the actual percentage of lime is fixed by specification irrespective of the silica and alumina contents, the amount found on analysis should always be considered in conjunction with the quantity of matter volatile

¹ Which is less than 2·85 and more than 2·0, and is therefore satisfactory.

on ignition, i.e. the water and carbonic anhydride. Otherwise an erroneous opinion may be formed as to the quality of the cement, causing loss to the manufacturer as well as annoyance to the engineer and the consumer by groundless rejection of the cement.

For example, a manufacturer prepares cement to a specification which fixes the lime between the maximum and minimum limits of, say, 62 and 60 per cent. Delay takes place in the sampling, or the sample drawn gets carelessly exposed to atmospheric influence before the analysis is made, with the result that moisture is absorbed and, the loss on ignition being increased, the percentages of the other ingredients are proportionately reduced, and the lime present in the aerated sample is found to be only 59.59 per cent.

The cement is consequently rejected as being below the minimum allowed, namely, 60 per cent. This example of what has often happened in practice shows that in cases in which an analysis is specified the sample should be taken as soon as possible after the cement reaches the consumer, and be placed immediately in a hermetically sealed receptacle, such as a glass-stoppered bottle or airtight tin, and thus kept free from exposure to the atmosphere until the analysis is made.

SPECIFIC GRAVITY

The specific gravity test for cement was introduced to supersede the old "weight per bushel" test as a means of determining whether or not the cement had been thoroughly burnt, it being held that a well-burnt cement would give a higher specific gravity than a lightly burnt one.

This theory has been proven to be erroneous, it having been found that the result of the test depends more upon the degree to which the cement has been aerated. Inasmuch, however, as the specific gravity of cement, adulterated with various additions—e.g. slag and the so-called "natural" cements—is less than that of genuine Portland Cement, this test, in conjunction with the chemical analysis, serves as a check on the purity and genuineness of the material.

TEST OF LITTLE VALUE ALONE¹

While a minimum specific gravity clause is a feature of every specification for Portland Cement, there is probably no test which, taken by itself, might lead to more faulty conclusions. The test of itself is designed to detect underburning and adulteration. Unfortunately for any conclusions as to the latter we might draw, low specific gravity is often, and indeed is usually, caused by "ageing" of the cement, so that to reject a cement because of a

¹ Professor Richard K. Meade, *Portland Cement*.

low specific gravity may be to reject it because it has been well seasoned. It is now generally considered that cement is greatly improved by seasoning, as the water and carbon dioxide of the air react with any free or loosely combined lime in the cement, which might otherwise cause the latter to be unsound. As the cement absorbs these constituents from the air its specific gravity becomes less and less. This is as it should be, since the specific gravity of calcium carbonate is only 2.70, and that of calcium hydrate only 2.08, and these are the two compounds probably formed during seasoning.

If a sample which has been kept for some time is dried at 100° C., its specific gravity will be found to be higher than it was in the undried condition, but still not as high as when it was freshly made. If this sample be subjected to a strong ignition in a platinum crucible over a good blast lamp its specific gravity will still further increase, and may even be more than the original specific gravity of the freshly made cement, in the case where the latter has been poorly burned. The following specific gravities, determined at different times, of a number of Portland Cements, illustrate the above facts:—

	SPECIFIC GRAVITY.				
	Sample No.				
	1	2	3	4	5
When made	3.19	3.21	3.16	3.15	3.20
After 28 days, undried . . .	3.11	3.12	3.10	3.09	3.08
" " dried at 100° C. . .	3.16	3.18	3.14	3.12	3.14
" 6 months, undried . . .	3.08	3.04	3.08	3.03	3.04
" " dried at 100° C. . .	3.13	3.09	3.12	3.09	3.09
" " ignited	3.18	3.21	3.18	3.15	3.19

Reference to the above table shows that samples 2, 4, and 5 would have failed to come up to the standard specific gravity specification after six months, and yet briquettes made of the samples at the same time the specific gravity determinations were made showed the cement to be at its best after storage for that length of time.

If the specific gravity of cement is not lowered by storage no seasoning has taken place, and consequently no benefits have been derived by the cement from ageing. Determinations of specific gravity made both on the undried and dried samples of cement may give us an insight into the amount of seasoning the cement has had. If the two results agree closely it is probable that the cement is fresh, but if these results vary by 0.05 or more we may assume that the cement has been in the storage for a few weeks at least.

The specific gravity determination is of little value in determining whether cement has been underburnt or not. The experienced cement chemist at the mill can see at a glance by looking at the clinker if it is underburned, and the engineer or inspector can judge better by the test for soundness. It is also, for the reasons given above, no indication of adulteration.

BRITISH STANDARD SPECIFICATION

Summary

When presented by the manufacturer for testing, cement shall not be less than 3·10.

The specific gravity of a substance denotes the ratio of the weight of any volume of that substance to an equal volume of pure water.

Since, in the metric system, the cubic centimetre is taken as the base of the gramme weight, it follows that the specific gravity of a substance becomes the ratio of its weight in grammes to its volume in cubic centimetres.

Many forms of apparatus have been devised for making tests of the actual specific gravity, all of which are based on the principle of measuring the amount of liquid displaced by a definite weight of material.

Procedure

The determination must be made with the very greatest care and accuracy, and experience with various types of "flask" has shown the "Schumann" to be one of the simplest and most suitable for the use of those who are only called upon to make a test occasionally. The bottle is filled with paraffin or turpentine to the zero mark on the graduated tube (or slightly above it) and stood in cold water, the temperature of which is noted and must remain constant for thirty minutes.

The height of the paraffin is then read off and noted; fifty grammes of cement are introduced, a little at a time. Any adhering to the sides of the tube must be washed down by carefully shaking up some of the paraffin. After removing air bubbles by gently knocking the bottle on a rubber or cloth pad, the apparatus is again set aside in the cold water to bring the temperature to the same degree as when the first reading was taken; and the level of the liquid is again noted.

The specific gravity is then obtained from the formula—

$$\text{Specific gravity} = \frac{\text{Weight of cement}}{\text{Increase in volume}}$$

The three points to be specially noted are :—

1. The paraffin used must be dry. This can be secured by shaking up and standing over calcium chloride for a short time.

2. The temperature of the apparatus must be the same after each reading.
3. All air bubbles must be removed by tapping as described.



Schumann's Apparatus for Specific Gravity.

The following table gives the equivalent specific gravity for various increases in volume :—

Increase in volume (50 grammes cement).	Specific gravity.	Increase in volume (50 grammes cement).	Specific gravity.
15 c.c.	3.333	15.90 c.c.	3.145
15.1 "	3.312	15.95 "	3.135
15.2 "	3.290	16.00 "	3.125
15.3 "	3.268	16.05 "	3.115
15.4 "	3.246	16.10 "	3.105
15.5 "	3.225	16.15 "	3.095
15.55 "	3.215	16.20 "	3.086
15.60 "	3.205	16.25 "	3.077
15.65 "	3.195	16.30 "	3.067
15.70 "	3.185	16.35 "	3.058
15.75 "	3.175	16.40 "	3.049
15.80 "	3.165	16.45 "	3.039
15.85 "	3.155	16.50 "	3.030

For the determination of the specific gravity of cement the committee approve the use of a bottle of the form shown on plate 5, B.S.S., 1915.

SPECIFIC GRAVITY DETERMINATIONS BY DIFFERENT EXPERTS IN
THEIR USUAL WAY UPON THE SAME SAMPLE OF CEMENT

“Personal Equation”

Expert A	.	.	Specific gravity	3·055
” B	.	.	”	” 3·130
” C	.	.	”	” 3·086
” D	.	.	”	” 3·115
” E	.	.	”	” 3·110

CHAPTER XIII

FINENESS

THE fineness to which cement is ground is a matter of considerable importance; with the growth of the industry this condition has become fully realized. Many of the old records show cements leaving residues of 25 to 30 per cent on a sieve having fifty holes per lineal inch = 2,500 per square inch.

It is now conclusively proved that only the very fine or impalpable powder present has cementing qualities, the residue retained on a sieve having 180 holes per lineal inch (= 32,400 per square inch), being devoid of cementitious value.

The fineness of the material, therefore, is a measure of its cementing value, and a fine cement will be much stronger when mixed in a mortar, or it can be mixed with a larger proportion of sand than a coarse one and yet attain the same strength.

Again, the hardening of cement is caused by the solution and subsequent crystallization of certain of its elements, so that this action will be quickened by the fineness of the particles, and the ultimate strength will be sooner attained.

Fineness of the cement also decreases the liability to unsoundness, the fine particles being seasoned more quickly.

BRITISH STANDARD SPECIFICATION

Summary

100 grammes, approximately 4 oz., continually sifted for fifteen minutes.

	Diameter of sieve wire.	Residue not to exceed
180 × 180 mesh sieve, 32,400 holes per square inch	0.0018 inch	14 per cent
76 × 76 mesh sieve, 5,776 holes per square inch	0.0044 ,,	1 ,,

Apparatus required

Scales.

Metric weights.

Sieve having 76 holes per lineal inch = 5,776 per square inch.

,, ,, 180 ,, ,, = 32,400 ,, ,,

Procedure

Weigh out 100 grammes of cement.

Place carefully, without loss, on the 180 mesh sieve. Shake for fifteen minutes, or until no more residue is coming through, which can easily be seen by sifting over a piece of white paper. One corner of the sieve may be tapped gently on to the table

or bench, but great care must be taken that none of the material is jolted over the side of the sieve.

Weigh the residue—not the flour which has passed through, which is liable to loss during the operation of sifting. Each gramme of residue, of course, equals 1 per cent. Take care that no material is lost in the weighing, and that none is left on the 180 sieve.

Transfer the residue after weighing to the 76×76 sieve. Shake as before and then weigh the residue again.

Sieves should be carefully brushed when each test is completed. The use of dirty sieves will affect the results obtained.

By continual use, especially if kept in a damp place, the mesh of the wire is likely to become choked or corroded, especially in the case of the finer sieve, in which case the results become absolutely misleading and incorrect.

Sieves can be cleaned by washing in very dilute hydrochloric acid and then with clean fresh water. Afterwards they must be thoroughly dried.

No sieve wire which has become distorted or damaged in any way should under any circumstances be used, and there must be no recesses in the frame in which residues could lodge.

The sieves used must be made of correct standard wire. It will be readily understood, especially in connexion with the very fine sieve (the 180), that the diameter of the wire with which it is woven has an important bearing on the size of the hole, which is the essential factor. The Standard Specification prescribes the diameter of the wire for each sieve. (See p. 129.)

Other sieves in occasional use are :—

$50 \times 50 =$	2,500 holes per square inch.
$100 \times 100 =$	10,000 " " "
$200 \times 200 =$	40,000 " " "

It is very difficult, if not impossible, to obtain wire cloth of absolute and uniform accuracy, especially in the finer meshes.

¹ OBSERVATIONS ON FINENESS

Limitation of the Sieve Test

The fineness to which cement is ground is an important point. Since cement is usually used with sand, the strength of the mortar increases with the fineness of the cement, because the greater is the covering power of the cement, i.e. the more parts of cement come into action with the sand. A test for fineness is nearly always included in cement specifications, as the indications from a fair degree of fineness, coupled with proper tensile strength, neat, are that the cement will give good results when used with sand.

At the same time the most rigid fineness specification could be filled by a cement which would be many degrees too coarse.

¹ From Meade's *Portland Cement*.

Some of the older specifications could be easily filled by a product which would show almost no setting qualities and no sand-carrying capacity. If a sample of clinker is crushed in an iron mortar by a pestle and sieved as fast as it is ground through a 100 mesh screen a product will be obtained, 100 per cent of which will pass a 100 mesh screen. Many of the older specifications call for only 90 per cent. If a pat is made of this cement it will just about cohere. If, however, the fine particles are sieved through a 200 mesh screen, and the flour washed off the coarse particles by benzine and the latter driven off by heat, the product will still all pass a 100 mesh sieve, and yet will have no setting properties. If another sample is ground in a mortar and sieved after every few strokes of the pestle through a 200 mesh screen it will all pass a 200 mesh sieve and yet will, nevertheless, be almost worthless as a cement. When washed free from its flour with benzine it will just about hold together. In the writer's laboratory there is a Braun's gyratory muller for grinding samples, in which the grinding is done by an enclosed round pestle revolving in a semi-hemispherical mortar. In the bottom of the mortar is a hole, which can be stopped by a plug. The grinding may be done in two ways: one by feeding the sample into the hopper in the cover and allowing it to work its way out at the bottom, then sieving out the fine material from the coarse, and returning the latter through the grinder, and so on until all has passed the sieve; the other by placing the plug in the bottom of the mortar and allowing the pestle to work upon the material until the latter has reached the desired fineness. Two samples of cement were prepared from the same lot of clinker by these methods. One sample, the one made by passing the clinker through the muller and sieving out the 200 mesh particles after each grind, would, of course, all pass a 200 mesh sieve. The other sample, the one made by grinding the whole sample to the desired fineness without screening, tested 96 per cent through a 100 mesh sieve and 75.6 per cent through a 200 mesh sieve. Sand briquettes were made of these two lots of cement with the following results:—

Samples made by	7 days.	28 days.	3 months.	6 months.
	lb.	lb.	lb.	lb.
Grinding and screening to fineness (all 200 mesh)	Broke in clips	Broke in clips	Broke in clips	28
Grinding to fineness without screening	215	295	324	318

The cementing value of Portland Cement depends upon the percentage of those infinitesimal particles which we call flour. No sieve is fine enough to tell the quantity of these present.

¹INFLUENCE OF FINE GRINDING OF CEMENT UPON ITS SETTING TIME

Cement No.	Per cent, passing a No. 200 sieve.					
	75	80	85	90	95	100
	Setting time (initial set) in minutes.					
1	255	246	192	75	12	2
2	105	106	100	100	22	6
3	120	115	100	95	60	35
4	240	200	180	115	60	30
5	240	210	110	55	15	5
6	200	190	175	100	25	2
7	100	100	90	80	25	5
8	115	105	100	75	30	10

At the same mill it is probable that the sieve test is relative, but to the engineer, who is called upon to examine the product of many mills using different systems of grinding, the sieve test is hardly to be expected to give the relative percentage of flour in each. The products of the Griffin mill and of the ball and tube mill probably differ much in the percentage of flour present, even when testing the same degree of fineness on the 200 mesh sieve. Even with the ball and tube mill system, one ball mill and two tube mills would probably give a product with a higher percentage of flour than one tube mill and two ball mills, even when the cement was ground to the same sieve test. The size screen on the ball mills probably also influences the percentage of flour in a product of a certain fineness.

“The influence of fineness upon the rate of set of cement is in some instances quite marked; in other instances this is much less noticeable. If any effect is produced at all, and there generally is, it is to make the cement quicker setting—in some instances so quick-setting as to be unfit for use, and often where this is the case additions of plaster of Paris fail to retard the set sufficiently to allow the cement to be used.”

¹ SHOWING EFFECT OF FINE GRINDING OF CEMENT ON SOUNDNESS
Result of Five-hour Steam Test (A.S.C.E.)

No.	As received.	Ground to pass No. 200 mesh sieve.	Ground to an impalpable powder.
1.	Checked	Sound	—
2.	Checked	Sound	—
3.	Checked	Slightly checked	Sound
4.	Checked	Slightly checked	Sound

¹ From Meade's *Portland Cement*.

¹ SHOWING INCREASE IN SAND STRENGTH DUE TO FINE GRINDING
TENSILE STRENGTH IN POUNDS PER SQUARE INCH

Neat

	1 day.	7 days.	28 days.	3 mths.	6 mths.	1 year.	2 years.
As received . . .	327	630	725	720	760	825	850
Ground to pass a 200 mesh sieve .	210	525	540	540	560	575	560

1 : 3 Mortar

	1 day.	7 days.	28 days.	3 mths.	6 mths.	1 year.	2 years.
As received . . .	—	278	357	387	390	410	425
Ground to pass a 200 mesh sieve .	—	480	555	575	615	623	640

FINENESS DETERMINATIONS BY DIFFERENT EXPERTS IN THEIR
USUAL WAY UPON THE SAME SAMPLE OF CEMENT

"Personal Equation"

Experts.	Sieves.			
	50	76	100	180
A	Trace	0.7	1.5	16.0
B	—	0.6	1.6	11.0
C	—	0.11	2.1	12.2
D	—	0.11	2.2	20.0
E	Trace	0.7	2.1	11.2

¹ From Meade's *Portland Cement*.

CHAPTER XIV

TENSILE STRENGTH

THIS test is to obtain a measure of the strength of the material as used in actual work.

While it is impossible to formulate definite ratios between the ultimate strengths of cement under different forms of stress, investigators have shown that the strength of cement in tension forms the most reliable basis in calculating the values of the strength under forms of stress.

BRITISH STANDARD SPECIFICATION

Summary

Mode of gauging—

Neat.—The cement shall be mixed with such a proportion of water that after filling into the mould the mixture shall be plastic.

Sand.—The mixture of cement and sand shall be gauged with so much water as to be moist throughout, but no surplus of water shall appear when the mixture is gently beaten with a trowel into the mould.

Briquettes of the form shown in fig. 1, plate 1, B.S.S., to be removed from mould when set, and kept in damp atmosphere for twenty-four hours after gauging, then placed in fresh water (renewed every seven days) until required for breaking.

When breaking briquettes, load to be applied at rate of 100 lb. in twelve seconds. (See figs. 2 and 3, plate 1, of the specifications for standard type of briquette clip.)

Six briquettes to be gauged both for seven days and twenty-eight days, and the average taken as the tensile strength.

The briquettes shall bear on the average not less than the following tensile stresses before breaking.

Neat Cement

Seven days from gauging . . . 450 lb.

The increase from seven to twenty-eight days shall not be less than the following formula :—

$$\text{Breaking strength at 7 days} + \frac{40,000 \text{ lb.}}{\text{Breaking strength at 7 days}}$$

Cement and Sand

Seven days from gauging . . . 200 lb.

The increase from seven to twenty-eight days shall not be less than the following formula :—

$$\text{Breaking strength at 7 days} + \frac{10,000 \text{ lb.}}{\text{Breaking strength at 7 days}}$$

Apparatus required

Gauging slab of non-porous material (marble, glass, slate, or iron).

Scales and weights.

Briquette—moulds and plates.

Trowel (about $7\frac{1}{2}$ oz.).

Graduated measuring glass—50 c.c. capacity.

Standard Leighton Buzzard sand.

Tensile machine.

Procedure. (1) For Testing Neat Cement

Weigh out 200 grammes of cement. Measure the water, and gauge the cement in the manner already described.

The quantity of water to be used for gauging should be that quantity which will produce a plastic condition when the cement is packed in the mould, but care should be taken that the cement is kept in the form of a damp powder until then, when slight tapping will so consolidate it as to render it plastic, and, the air escaping before plasticity is reached, a solid and homogeneous briquette will be obtained. If, on the other hand, the cement is trowelled into a plastic mass before it is placed in the mould the air bubbles in the mixture cannot be excluded, and a briquette full of air spaces will result.

To ascertain the quantity of water that is required, which usually ranges from 18 to 22 per cent, according to the properties of the cement under test, a trial should be made with one or two briquettes, which, if not satisfactory, should not be included in the series from which the test records are to be made.

Place the mould (after *slightly* greasing it in order to prevent adhesion of any cement) on a non-absorbent base-plate—preferably of iron or steel.

In filling the moulds, enough material to about half fill them is first introduced and distributed evenly over the bottom with the fingers and thumbs, without exerting any appreciable pressure; any excess of material is then placed in and on the mould, extending about half an inch above it, and pressed in firmly with the thumbs without ramming. Any excess of material is now struck off with the trowel flush with the surface of the mould under a pressure of about 5 lb.

Every care should be taken to fill the mould completely with cement and to exclude all air bubbles. It is obvious that when testing such a small section as one square inch the mass should

consist entirely of cement, as even small voids will materially reduce the actual area under test and give rise to low and irregular results.

(2) *For Testing Cement with Three Times its Volume of Sand*

Note.—The British Standard Specification stipulates that Leighton Buzzard sand shall be used, so graded that all will pass through a 20 mesh sieve (400 holes per square inch) and be retained on a 30 mesh sieve (900 holes per square inch).

Weigh out 50 grammes of cement and 150 grammes of standard sand.

Mix thoroughly in the dry condition. Add water proportionate to the quantity required for the neat briquette as set out in the following table, and carefully pack the material into the mould as described for the neat briquettes, remembering that even greater care is required to consolidate the sand specimens.

Provision has now been made in the third revision of the B.S.S. for a standard spatula, shown on plate 2, for patting down the material (cement and sand) in the moulds until water appears on the surface.

No ramming or hammering in any form will be permitted during the preparation of the briquettes, which shall then be finished off in the moulds by smoothing the surface with the blade of a trowel.

PROPORTION OF WATER FOR GAUGING SAND BRIQUETTES
(Based on that found requisite for neat cement.)

Neat.	1 cement, 3 standard sand.	Neat.	1 cement, 3 standard sand.	Neat.	1 cement, 3 standard sand.
Percentage of water.	Percentage of water.	Percentage of water.	Percentage of water.	Percentage of water.	Percentage of water.
15	8.0	23	9.3	31	10.7
16	8.2	24	9.5	32	10.8
17	8.3	25	9.7	33	11.0
18	8.5	26	9.8	34	11.2
19	8.7	27	10.0	35	11.5
20	8.8	28	10.2	36	11.5
21	9.0	29	10.3	37	11.7
22	9.2	30	10.5	38	11.8

GENERAL NOTES

In some countries the Boehme hammer or some other mechanical ramming apparatus is used for sand specimens, but this is not permitted by the British Standard Specification.

See that the briquette moulds are free from any excess of

lubricating material. The use of a large quantity of oil or grease for the purpose of preventing the cement sticking to the mould will often entirely destroy the qualities of the cement placed therein.

When the mould is being filled some quantity of cement of necessity falls on and about it, and this should never be gathered up and used to form the briquette, because such cement may have oil adhering thereto, which thus finds its way into the interior of the briquette and, destroying the hardening properties of the cement, prevents its complying with the specification.

Briquettes should always be made singly, especially when the cement is quick-setting.

The custom of gauging enough cement at one time to fill several moulds is objectionable, and frequently leads to trouble—the first briquette, and perhaps the second, turn out all right, but the remainder may fall short of the required strength, because the cement had begun to set before the briquettes were finished. The setting of the cement once having been checked is seriously retarded, if not altogether prevented. Again, it is objectionable to use “nests” of moulds, say four or six, as is frequently done, even if the briquette is gauged singly, as with a moderately quick-setting cement the packing of the last briquette disturbs by vibration the setting of the first of the series, which may be already in progress.

Each mould should be quite separate and distinct and, when filled, placed where no vibration can disturb it.

Even slow-setting cements may not escape failure under these two headings.

All briquettes, whether neat or with sand, when first gauged should remain in the mould for twenty-four hours, and be kept in a damp atmosphere at normal temperature during the whole of that period.

They are then carefully removed and immersed in water at 58° to 64° F. until due for breaking.

Briquettes should be broken at the appointed dates, immediately after being taken out of the water, and should not be left about to dry before being tested.

All the precautions recommended for the making of neat briquettes apply equally when making briquettes containing a mixture of cement and sand.

Many types of tensile testing machines are in use. Whatever form be used, the briquettes should be placed evenly and squarely in the standard clips, so that when the strain is applied the pull is even on all parts of the square inch section and no side strains are set up, which would result in defective fracture and irregular results. The jaws for gripping the briquettes must be of the standard type.

It is important also that the strain be applied evenly at a uniform rate. The standard specification provides for the application at the rate of 100 lb. in twelve seconds—very irregular results will be obtained if care be not taken in this particular.

The result of any briquette which is exceptionally low should be eliminated, as it is evident the fault must be due to manipulation, because whatever strain the other briquettes of the series may be capable of standing all should bear under like conditions.

In foreign countries where the Metric system is in use the results of tensile and crushing tests are given in kilogrammes per square centimetre—a comparative table showing the equivalent in kilogrammes per square centimetre, for the British standard of pounds per square inch and tons per foot, is given.

In making tests for breaking at long periods a falling away in the tensile strength is sometimes noticed at certain intervening dates. It is well known to manufacturers and those interested in the industry that there is a time in the life of set cement when some physical alteration in its condition takes place, but there is no need to be alarmed by a slight falling away in the tensile strength at one or more of these periods.

It will almost invariably be found that at later dates the cement recovers, and thereafter gains steadily in strength.

These lapses are sometimes noticed at fourteen days, but more often at from nine to twelve months after gauging.

CHAPTER XV

TIME OF SETTING

THIS test is made to determine the fitness of the material for a given piece of work. In actual construction, a cement should not have begun to set before being placed in the work.

The "set" takes place in two stages—first the "initial" set due to the more rapid hydration and crystallization of the calcium aluminate of the cement, and then the "final" set due to the slower hydration and crystallization of the calcium silicate of the cement. The initial set is of the greater importance, as it is essential for good concrete that the mortar should not be handled or disturbed after this begins—that is to say, the concrete or mortar must be mixed and deposited in its intended position within the period of time before the initial set begins. For instance, if the initial set of a cement be thirty minutes the mortar should, if possible, be deposited *in situ* within thirty minutes after adding the water. This, however, is susceptible of some latitude, for the mixture of aggregate with cement results in a somewhat slower initial set than occurs with neat cement.

BRITISH STANDARD SPECIFICATION

Summary

<i>Quick</i>	{ Initial set not less than 2 minutes. Final not less than 10 minutes, nor more than 30 minutes.
<i>Medium</i>	{ Initial set not less than 10 minutes. Final not less than 30 minutes, nor more than 3 hours.
<i>Slow</i>	{ Initial not less than 30 minutes. Final not less than 3 hours, nor more than 7 hours.

The cement shall be considered as finally set when, upon applying the needle gently to the surface of the test block, the needle makes a slight impression thereon,¹ while the attachment shown in the figure on plate 3 fails to do so (from third revision of B.S.S., 1915).

Apparatus required

Gauging slab of non-porous material.

Trowel.

Scales.

One 400 gramme weight (or two 200 gramme weights).

¹ It must be understood to mean a slight impression only and in no sense a piercing.

Graduating measuring glass, 50 c. capacity.

Large palette knife.

Standard needle. (The needle to be used is known as the Vicat.)

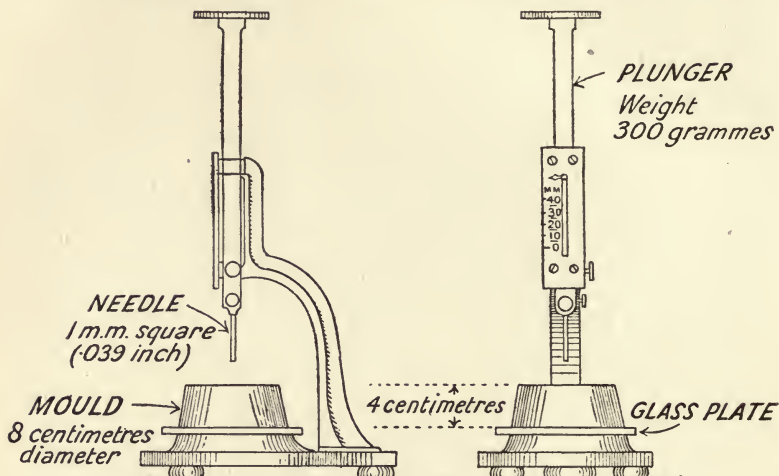

The Vicat Needle.

Description

Weight of rod, complete with plunger and needle, 300 grammes (10.58 oz.).

Plunger 1 centimetre diameter.

Needle point, 1 millimetre square.

Depth of mould, 4 centimetres (1.57 inches).

Diameter of ditto, 8 centimetres ($3\frac{5}{8}$ inches).

Procedure

Weigh out and place on the slab 400 grammes of cement. (See general notes on gauging.)

Measure the quantity of water in a graduated glass. The majority of cements require between 20 and 24 per cent to bring them into a plastic condition, and the first mixing should be made with the lesser quantity; if this be found insufficient a further 1 or 2 per cent as required can afterwards be added. Should the quantity first taken be found excessive, it will be necessary to mix afresh with less water.

Do not use an excess of water, which results in a scum on the surface of the pat, rendering observation of the real impressions difficult and causing divergent results, besides prolonging the actual setting time.

The moment when the water is added to the cement should be noted, and the "time" of "setting" reckoned therefrom.

After working the paste or mortar to the proper consistency, it is pressed in the mould ring (which is placed on a glass or steel plate) and smoothed off with a trowel perfectly level with the top edge of the ring. The paste confined in the ring and resting on the non-absorbent plate is then placed under the rod bearing the needle (1 millimetre square) with which the initial and final setting times are determined. The initial set is recorded when the needle, upon being lowered gently on to the cement, fails to penetrate to the plate at the bottom. The final or complete set is recorded when the needle fails to make any appreciable impression on the surface of the cement.

The set, therefore, should be calculated in the following example:—

Water added to cement	10.45 a.m.
Needle failed to penetrate pat	11.55 a.m.
Initial set	1 h. 10 m.
Needle made only faint impression	2.30 p.m.
Final set	3 h. 45 m.

A fruitful source of dispute in connexion with the setting time of cement is the question of what constitutes faint impression—one operator carrying on the test until practically no mark at all is visible, and thus recording a much longer setting time than another operator who reads his final set at a much earlier

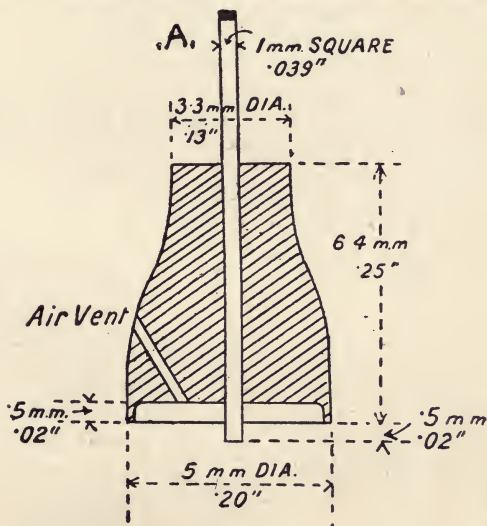

Enlarged view of Needle A.

point. Various attempts have been made to arrive at a standard depth of impression for reading the final set; but the advent of the third revision of the B.S.S. 1915 places the question of final setting on a more satisfactory basis, provision being made for a needle fitted with a metal attachment hollowed out so as to leave a circular edge 5 mm. (0.020 in.) in diameter, the end of the needle projecting 0.5 mm. (0.20 in.) beyond the edge.

The cement supplied by a manufacturer to a required setting time may vary considerably in its setting characteristics in accordance with the amount of aeration to which the sample is subjected, and this unavoidable variation, due to atmospheric causes, is another source of trade disputes. As has already been said, the cement should be tested as soon as possible after it is received.

The proportion of water used in gauging, as well as the temperature and humidity of the surrounding atmosphere, play a not inconsiderable part in determining the setting of cement. A hot dry atmosphere will hasten the setting, and a cold or moist atmosphere will retard it—hence the importance of uniform atmospheric conditions in the testing-room.

The setting time of cement is also influenced by a number of other factors—

- (1) The fineness to which the cement has been ground.
- (2) The time that has elapsed since manufacture.
- (3) The conditions under which the cement has been stored.
- (4) The action of material, such as gypsum, added for the purpose of retarding the setting time.
- (5) The possible presence of soluble materials in the aggregate used with the cement to form the concrete.
- (6) The composition and the clearness or the reverse of the water used for gauging.
- (7) Accidental causes, such as the introduction of oil, grease, or other foreign matter.

A comparative table is here given, showing the equivalent pressure per square inch exerted by the different needles described:—

Description.	Weight.	Size of Needle.	Area of Needle.	Pressure exerted by Needle.
			square inch.	lb. per square inch.
British Standard Vicat	300 grammes = 10.58 oz.	1 mm. sq. = 0.03937	0.001550	426
American Gilmore Initial	4 oz.	$\frac{1}{8}$ " diam.	0.005450676	46
Final	16 oz.	$\frac{1}{4}$ " ,,	0.00136353	733

In addition to the Vicat needle there are others in use in America known as the "Gilmore" needles. These consist of a small needle weighing 4 oz. with a point $\frac{1}{12}$ inch in diameter for determining the initial set, and a larger needle weighing 16 oz., with a point only $\frac{1}{24}$ inch in diameter, for determining the final set.

¹ EFFECT OF STORAGE OF PORTLAND CEMENT ON ITS SETTING PROPERTIES

"No property of Portland Cement is harder to control than its 'set', or gives the manufacturer more trouble. This is not so much because of any difficulty in the way of making a slow-setting cement, as it is of making one which will remain slow-setting under all ordinary conditions of storing and ageing.

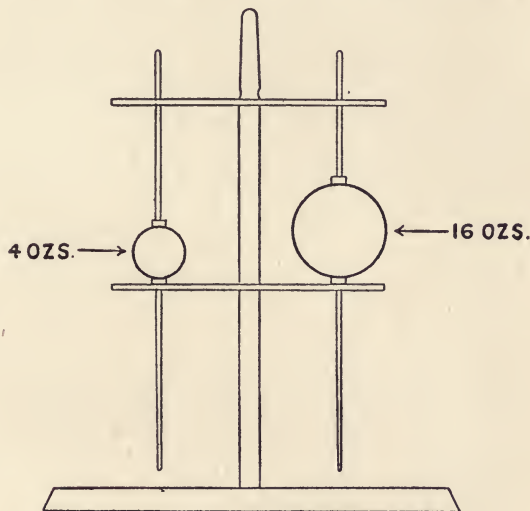

Gilmore Needles mounted on Stand.

Every manufacturer can cite instances of cement which left the mill having the proper setting time, and yet which turned up at the job with a 'flash' set. Bins of freshly made cement will frequently test slow-setting and yet, after seasoning some weeks, will show quick set on again testing.

"The converse of this is also true; some cements which, when freshly made, are quick-setting, will in time become slow-setting, and, again, slow-setting cements may become quick-setting and then slow-setting again."

¹ From Meade's *Portland Cement*.

¹ INFLUENCE OF VARIOUS PERCENTAGES OF WATER USED TO GAUGE
THE PATS ON THE SETTING TIME OF PORTLAND CEMENT

Percentage of Water.		Sample No.			
		1	2	3	4
14	Initial set	h. m. 0 10	h. m. 2 10	h. m. 0 10	h. m. 0 25
	Final set	2 45	6 0	0 35	0 55
16	Initial set	0 20	2 20	0 10	0 25
	Final set	3 50	6 0	0 35	1 0
18	Initial set	1 5	2 20	0 10	0 35
	Final set	5 0	6 15	0 35	1 15
20	Initial set	2 10	2 40	0 8	1 25
	Final set	6 20	6 15	0 30	4 0
22	Initial set	4 20	3 0	0 5	2 15
	Final set	8 0	6 50	0 30	5 0
24	Initial set	5 10	5 0	0 20	3 0
	Final set	12 10	8 30	0 50	6 10

¹ SHOWING THE EFFECT OF PLASTER OF PARIS ON THE SETTING
TIME OF PORTLAND CEMENT

Percentage of Plaster of Paris added.	Percentage of Water used to make pats.	Initial Set.		Final Set.	
		h.	m.	h.	m.
—	25	0	2	0	6
0.5	23	0	5	0	10
1.0	23	0	50	4	0
1.5	23	2	50	6	0
2.0	22	3	0	6	15
3	22	1	45	5	20
4	22	0	35	4	0
5	22	0	16	2	0
10	22	0	16	1	30
20	22	0	9	0	20

¹ From Meade's *Portland Cement*.

¹ INFLUENCE OF TEMPERATURE ON THE RATE OF SETTING OF PORTLAND CEMENT

Temp. degrees F. ²		Sample No.							
		1		2		3		4	
		h.	m.	h.	m.	h.	m.	h.	m.
35	Initial set	3	0	5	0	2	0	2	10
	Final set	8	0	10	0	6	0	6	0
45	Initial set	1	5	3	0	1	15	1	5
	Final set	3	15	7	30	3	30	3	15
60	Initial set	0	30	2	30	0	15	0	3
	Final set	1	10	6	0	1	0	0	10
80	Initial set	0	4	2	0	0	2	—	—
	Final set	0	10	5	30	0	5	—	—
100	Initial set	—	—	0	45	—	—	—	—
	Final set	—	—	3	10	—	—	—	—

SHOWING THE EFFECT OF GYPSUM ON THE SETTING TIME OF PORTLAND CEMENT

Percentage of Gypsum added.	Percentage of Water used for making pats.	Initial Set.		Final Set.	
		h.	m.	h.	m.
1	23	0	2	0	10
2	23	2	40	5	50
3	22	2	50	5	50
5	22	3	15	6	0
10	22	3	0	5	40
20	22	3	20	6	0

“PERSONAL EQUATION”

SETTING TIME DETERMINATIONS BY DIFFERENT EXPERTS IN THEIR USUAL WAY UPON THE SAME SAMPLE OF CEMENT

Expert.	Room Temperature.	Water per cent.	Setting Time.			
			Initial.		Final.	
			h.	m.	h.	m.
A	53° F.	25	1	13	2	12
B	58° F.	25	0	45	2	15
C	58° F.	22	0	50	2	5
D	50° F.	22½	0	55	4	47
E	55° F.	20	0	50	2	40

¹ From Meade's Portland Cement.

² Of room during setting time, and of cement and of water used to gauge pats.

INFLUENCE OF AGEING ON THE SET OF PORTLAND CEMENT

		Sample No.						
		1	2	3	4	5	6	7
Fresh	Initial set	h. m. 2 50	h. m. 3 10	h. m. 4 10	h. m. 2 40	h. m. 0 2	h. m. 0 10	h. m. 0 4
		Final set	6 0	6 40	8 0	6 15	0 15	0 25
1 week old	Initial set	1 30	0 10	2 15	0 3	0 2	0 5	0 4
	Final set	4 30	0 25	6 0	0 8	0 10	0 15	0 10
2 weeks old	Initial set	0 3	0 5	1 25	0 3	0 15	0 30	0 4
	Final set	0 7	0 11	3 40	0 8	0 35	1 5	0 10
4 weeks old	Initial set	0 3	0 5	0 30	0 5	1 30	1 50	0 15
	Final set	0 7	0 15	1 50	0 11	4 10	4 45	0 30
3 months old	Initial set	0 30	0 4	0 10	0 3	1 35	2 0	2 40
	Final set	1 15	0 15	0 30	0 8	4 0	6 10	6 5
6 months old	Initial set	0 25	0 20	—	0 3	2 10	2 0	2 10
	Final set	1 15	1 10	—	0 8	6 0	6 10	5 40
1 year old	Initial set	0 25	0 55	2 20	0 4	2 0	1 40	2 15
	Final set	1 10	2 30	5 40	0 10	5 30	5 5	6 0

SHOWING THE EFFECT OF DEAD BURNED GYPSUM ON THE SETTING TIME OF PORTLAND CEMENT

Percentage of dead burned Gypsum added.	Percentage of Water used to make pats.	Initial Set.		Final Set.	
		h.	m.	h.	m.
1	23	0	6	0	10
2	23	1	45	5	10
3	23	1	47	5	30
5	23	2	0	5	40
10	23	1	50	5	0
20	23	2	20	5	0

SETTING TIME DETERMINATIONS BY DIFFERENT EXPERTS UPON THE SAME SAMPLE OF CEMENT, WITH AN UNIFORM PERCENTAGE OF WATER, VIZ. 22 PER CENT, AND ALL AS FAR AS POSSIBLE AT A TEMPERATURE OF 60° F.

Expert.	Final Setting Time.		Temp. degrees F.
	h.	m.	
A	1	40	61
B	1	15	60
C	1	27	60
D	2	30	56 to 60
E	0	38	64
F	1	25	60
G	1	40	60
H	0	55	60
I	1	0	60

CHAPTER XVI

SOUNDNESS OR CONSTANCY OF VOLUME

THE object of this test is to develop those qualities which tend to destroy the strength and durability of a cement and is therefore the most important quality, for although a sample may pass all other tests satisfactorily, if it fail in the soundness test it is worthless as a material for construction.

Failure is revealed by cracking, checking, swelling, or disintegration, or all of these phenomena.

A cement which remains perfectly sound is said to be of constant volume.

Tests for soundness are divided into two classes, "normal" and "accelerated".

(Accelerated tests were introduced to hasten the action of the expansive ingredients and to develop within a few hours for which the normal tests require weeks.)

NORMAL TESTS

A pat of neat cement is immersed in water, maintained as near 70° F. as possible for twenty-eight days, and observed at intervals; a similar pat is maintained in air at ordinary temperature and observed at intervals.

ACCELERATED TESTS

A pat of neat cement paste is exposed in any convenient way in an atmosphere of steam, or immersed in cold water which is raised to boiling-point in about thirty minutes and maintained thereat for six hours.

For these tests, pats 3 inches in diameter, $\frac{1}{2}$ in. thick at the centre, and tapering to a knife edge, should be made upon a clean glass plate 4 inches square from cement paste of normal consistency.

All pats are put into the baths with a plate of glass on which they have been allowed to set.

SOUNDNESS

(British Standard Specification)

Summary

Expansion.		Not to exceed
In Le Chatelier gauge after being aerated	24 hours	10.0 mm.
" " " "	7 days	5.0 mm.

LE CHATELIER TEST
(Accelerated)

Apparatus required

Gauging slab of non-porous material.

Le Chatelier gauge—

Two glass plates about 4 inches square.

Small lead weight.

Graduated measuring glass—50 c.c. capacity.

Trowel.

Millimetre measuring rule.

Copper bath or other receptacle for boiling specimens.

Procedure

The mould is placed on one of the glass plates. Fifty grammes cement, gauged in the usual way, is filled into the mould, care being taken not to press the cement in too hard so as to force the ring open. It is then covered by another glass plate, a small weight being placed on the top to keep the plate in position, and

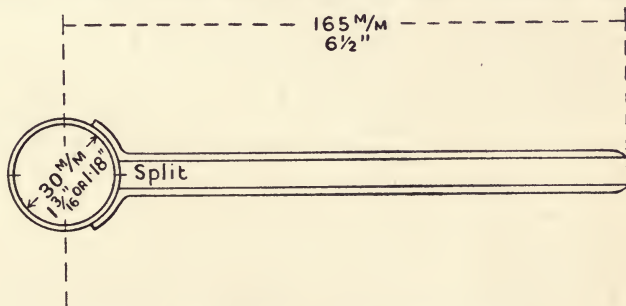

Split Cylinder of Spring Brass or other suitable metal, about $\frac{1}{2}$ mm. in thickness.

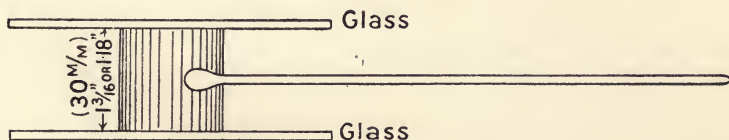

The Le Chatelier Gauge.

the mould is immersed in cold water for twenty-four hours. At the end of that time the distance between the needle points is measured and the mould is placed in cold water, which is heated until in fifteen to thirty minutes it is brought to the boil.

Boiling is continued for six hours and, after cooling, the distance between the needle points is again measured. The difference

between the two measurements represents the expansion of the cement.

OTHER TESTS FOR SOUNDNESS
(Accelerated)

Faija Test

One of the first accelerated tests, devised by Mr. Henry Faija in 1882, consists of a water-jacketed bath containing water which is maintained at a temperature of 115° F., and immediately a pat intended for the test has been gauged upon a plate of glass it is

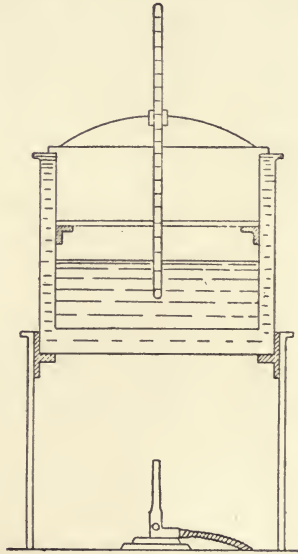

Faija's Soundness Test Apparatus.

placed on the shelf above the water, the lid is put on, and the pat is left to set in the steam-saturated atmosphere. When set hard it is placed in the water (at 115° F.) and allowed to remain for twenty-four hours.

The author states that if a test pat after the above treatment shows no signs of cracking or blowing and adheres firmly to the glass on which it was made it may be used with perfect confidence.

Deval Test

A similar bath is used for this test, in which the water is raised to a temperature of 174° F. In this case the pat is, after gauging, allowed to set in moist air at normal temperature. It is then placed in cold water in the Deval bath, which is raised to the above

temperature, at which it is kept and in which the pat remains for twenty-four hours.

Boiling Test

In this case the bath is not water-jacketed, for obvious reasons, and an ordinary pan of any kind will do. The procedure with regard to the pat is similar to the Deval test, except that the cold water in which the pat is placed is raised to boiling-point (212° F.) and maintained thereat for six hours.

In all of the above accelerated tests the pats are taken direct from the hot water, and need not remain in the water until it has cooled down.

Cold Water Pats

(Normal)

Pats gauged in the usual manner are allowed to set hard in moist air and are then placed in cold water for some days.

Plunge Pat Test

The pat is placed in cold water immediately after gauging, and allowed to set under water. It should be left in the water for three or four days, and if satisfactory will be found to have set hard and adhering to the glass plate on which it was gauged. This test is chiefly prescribed for cement required for under-water work. Slow-setting cements, particularly those to which gypsum has been added to retard the set, will not always stand this test.

The Bottle Test

Cement, mixed with water to the consistency of thick cream, is poured into a test tube and allowed to set. If it is unsound and expansion occurs in the course of a day or two, the glass will crack—or it may contract, in which case coloured water run into the tube will be seen to pass down between the cement and the glass.

Air Pat Test

It sometimes happens (more particularly with slow-setting cement) that a pat of neat cement, which has been allowed to set in the air, develops cracks which may be mistaken for expansion cracks, but which in reality are due to contraction. These contraction cracks usually arise from one or other of the following causes:—

- (1) An excessive quantity of water used for gauging.
- (2) Pat having been placed on wood or other absorbent material which withdraws the water required for setting the cement.
- (3) Pat having been exposed to a current of air during setting.
- (4) Pat having been exposed to sunlight or to a fire, gas-jet, or other heating agent during setting.

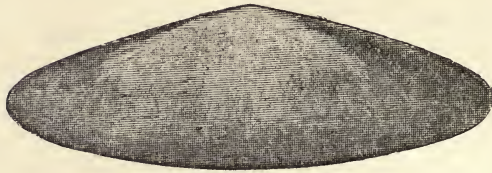

FIG. 1.

Fig. 1 shows a pat which has satisfactorily passed the test.



FIG. 2.

Fig. 2 shows shrinkage cracks.

These are usually caused by the use of too wet a mixture or produced by too great rapidity of drying. Dry air will usually produce this effect, so that such cracks indicate improper manipulation and not dangerous properties in the cement.

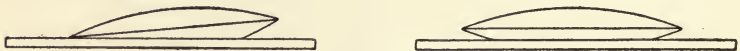

FIG. 3.

Fig. 3 shows cracks caused by the curling of the edges of the cement away from the glass while the pat still adheres.

This condition is common in air pats and is not dangerous unless extreme in character. It should not occur in water pats. If such cracks are found in water pats they denote the existence of qualities which should ordinarily condemn the sample.

If a pat is blotched, special consideration should be given to its cause, which may be either adulteration or underburning.

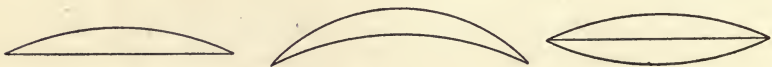

FIG. 4.

Fig. 4 shows pats which have left the glass because of sufficient adhesion, contraction, and expansion respectively.

The mere lack of adhesion in either air or water pats is not dangerous.

A curvature greater than a quarter of an inch caused by expansion or contraction should be sufficient to condemn the sample. Occasionally the glass will be cracked while the cement pat still adheres to it. This is not usually indicative of poor quality.

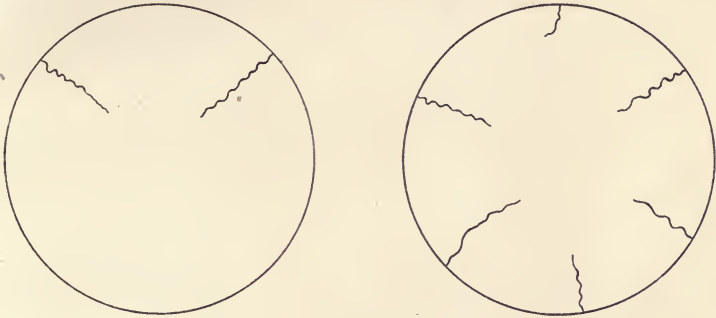

FIG. 5.

Fig. 5 shows the radial cracks incident to incipient disintegration. Such cracks should always warrant rejection of the sample.

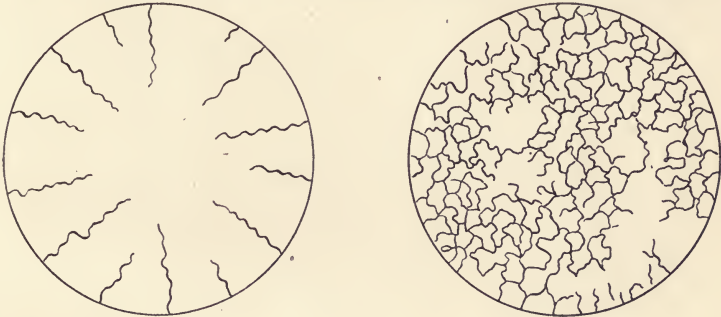

FIG. 6.

Fig. 6 shows examples of complete disintegration, which started as indicated in Fig. 5.

GENERAL INDEX

- A**ERO pulverizer, 46
 American pre-eminence in Portland Cement industry, 6
 Aspdin (Joseph), first used the term "Portland Cement", 3
 — his factory at Wakefield, 4
 Atlas Portland Cement Company, 40
- B**ALL and tube mills, 24
 Barrage at Assiout, 6
 Big hole blasting drills, 17
 Bradley three-roll mill, 28
 Brunel, used cement for Thames Tunnel, 4
- C**APACITY of various machines used for crushing, grinding, and conveying, 33-8
 — ball mills (preliminary mill dry grinding), 36
 — belt conveyors, 37
 — bucket elevators with gearing, 38
 — crushing rolls, 34
 — flint pebble tube mills (finishing mill dry grinding), 36
 — gyratory crushers, 33
 — large jaw crushers, 34
 — screw conveyors, 37
 — small jaw crushers, 34
 — steel ball mills (wet grinding), 35
 — steel ball tube mills (wet grinding), 35
 — steel ball tube mills (preliminary mill dry grinding), 36
- Centrifugal ball mill, 29
 Chemical composition, 123-8
 — British standard specification, 123
 — specific gravity, 124
 — test of little value alone, 124
- Comparative table of English and metric measures, 122
 — of English and metric weights, 122
 — of English and metrical stresses, 121
- Costs and statistics, 82-108
 — cement production and shipments during 1914 (U.S.A.), 87
 — labour costs per ton of cement, 83
 — plant, 83
 — specimens of daily reports, returns, etc., 90-108
 — systematic cost keeping, 88
- Crushers, types of, 22
- D**ESIGN and construction of a modern Portland Cement plant, 14-38
 — comparative cost data, 18
 — quarry practice, 16
 — site, 14
 — size of plant, 15
- Development of Portland Cement industry, 6-7
- E**DISON'S remarkable influence on the industry, 40
 Elkinton (W. B.), patent for making concrete, 4

- Equipment, carpenters and wheelwrights, 81
- machine shop, 80
 - mechanical, 80
 - — of plants erected during last five years, 109-16
 - smithy, 81

FINENESS, 129-33

- British standard specification, 129
 - determinations by different experts, 133
 - effect of fine grinding of cement on soundness, 132
 - increase in sand strength due to fine grinding, 123
 - influence on fine grinding of cement upon its setting time, 132
 - limitation of the sieve test, 130
- Francis & White (Messrs.), manufactory at Nine Elms, 4
- Frost (James), patent for "British Cement", 3
- Fuller-Lehigh pulverizer mill, 29
- crushing, 30
 - preliminary preparation of material for mill feed, 30

GAUGING cement, 118

- Germany, production in, 7
- Gilmore needle, 143
- Great Britain's position in the Portland Cement industry, 1-2
- Great Exhibition, gave impetus to the industry, 5
- Griffin mills, 26
- 40 in. giant Griffin mill, 27
- Grinding, 23

HISTORY of the Portland Cement industry, 3-5

JOHNSON (I. C.), manufactory at Gateshead, 4

MANUFACTURE, 8-13

- composition and manufacture of cement, 10
- synopsis of, from the raw material to Portland Cement, 10
- — burning of raw materials to incipient fusion, 10
- — cooling and grinding the clinker, 10
- — crushing, grinding, and mixing of raw materials, 10
- — definition:— British standard specification, 10; American and German standard specifications, 11
- — quarry, 10
- — wet and dry processes, 10-13

NILE Dam at Assouan, 6

PACKING, 79

- Panama Canal, 6
- Parker (James), patent for "terras", 3
- Pasley (General), applied name of "Roman Cement", 3

- Pasley (General), experiments and research work in Kent, 4
- Physical testing, 117-53
- Power plants, 51-77
- boiler plant, 66
 - choice of power units, 62
 - feed pumps, 68
 - importance of selection, 51
 - methods of driving, 55
 - steam and feed-water pipes, 73
 - superheaters, 76
 - type of power plant, 59
 - types of transmission, 55
 - water supply, 56
 - — treatment of impurities, 57
- R**AW materials, 8-13
- alkali waste, 8
 - blast-furnace slag, 9
 - chalk, 8
 - clay, 9
 - clayey limestone, 8
 - crushing, 21
 - grinding, 23
 - limestone, 8
 - marl, 8
 - proportioning, 9
 - shale, 9
 - storage, 19
- Rotary kiln, 39-50
- construction, 41
 - dust collectors, 49
 - fuel, 45
 - — coal, its storage, drying, and grinding, 45
 - — cooling, storing, and grinding the clinker, 48
 - — crude oil, 47
 - — natural gas, 48
 - — producer gas, 48
- Rotary kiln, idea of rotating furnace first conceived by Crampton, 40
- lining, 43
 - output in United States before and after establishment of rotary kiln, 40
 - Ransome's patent, 40
- S**ACK department, 79
- Sheppard (Samuel), his works at Faversham, 4
- Smeaton's experiments, 3
- Soundness or constancy of volume, 148-53
- accelerated tests, 148
 - air pat test, 151
 - boiling test, 151
 - bottle test, 151
 - cold-water pats, 151
 - Deval test, 150
 - Faija test, 150
 - Le Chatelier test, 149
 - normal tests, 148
 - plunge pat test, 151
- Stephenson, pointed out the excellence of cement, 4
- Storage, 78
- Sturtevant Patent Air Filter, 50
- Patent Dust Collector, 50
 - "ring roll" mill, 31
 - — "open door" accessibility, 32
 - "Steel Plate" Dust-collecting Fan, 50
- T**ENSILE strength, 134-8
- British standard specification, 134
 - proportion of water for gauging sand briquettes, 136
- Testing of cement, development of, 117

- Testing required for immediate use, 120
- Time of setting, 139-47
- British standard specification, 139
 - determinations by different experts, 145, 147
 - effect of dead burned gypsum on the setting time, 146
 - effect of gypsum on the setting time, 145
 - effect of plaster of Paris on the setting time, 144
- Time of setting: effect of storage of Portland Cement on its setting properties, 143
- influence of ageing on the set, 146
 - influence of temperature on the rate of setting, 145
 - influence of various percentages of water used to gauge the pats on the setting time, 144
- VICAT needle, 140

D. VAN NOSTRAND COMPANY
25 PARK PLACE
NEW YORK

SHORT-TITLE CATALOG
OF
Publications & Importations
OF
SCIENTIFIC AND ENGINEERING
BOOKS



This list includes all the books published by the
M. C. CLARK PUBLISHING CO.,
Chicago, Ill.,

and the technical publications of the following English publishers:

SCOTT, GREENWOOD & CO. JAMES MUNRO & CO., Ltd.
CONSTABLE & COMPANY, Ltd. TECHNICAL PUBLISHING CO.
ELECTRICIAN PRINTING & PUBLISHING CO.,

for whom D. Van Nostrand Company are American agents

Descriptive Circulars sent on request.

NOVEMBER, 1916

SHORT-TITLE CATALOG
OF THE
Publications and Importations
OF
D. VAN NOSTRAND COMPANY
25 PARK PLACE

The books published by the
MYRON C. CLARK PUBLISHING CO., Chicago, Ill.
are included in this catalog.

Prices marked with an asterisk (*) are NET
All bindings are in cloth unless otherwise noted

Abbott, A. V. The Electrical Transmission of Energy.....	8vo,	*\$5 00
—— A Treatise on Fuel. (Science Series No. 9.).....	16mo,	0 50
—— Testing Machines. (Science Series No. 74.).....	16mo,	0 50
Adam, P. Practical Bookbinding. Trans. by T. E. Maw.....	12mo,	*2 50
Adams, H. Theory and Practice in Designing.....	8vo,	*2 50
Adams, H. C. Sewage of Seacoast Towns.....	8vo,	*2 00
Adams, J. W. Sewers and Drains for Populous Districts....	8vo,	2 50
Adler, A. A. Theory of Engineering Drawing.....	8vo,	*2 00
—— Principles of Parallel Projecting-Line Drawing.....	8vo,	*1 00
Aikman, C. M. Manures and the Principles of Manuring..	8vo,	2 50
Aitken, W. Manual of the Telephone.....	8vo,	*8 00
d'Albe, E. E. F. Contemporary Chemistry.....	12mo,	*1 25
Alexander, J. H. Elementary Electrical Engineering....	12mo,	2 00

Allan, W. Strength of Beams under Transverse Loads. (Science Series No. 19.).....	16mo,	0 50
Allan, W. Theory of Arches. (Science Series No. 11.)..	16mo,	
Allen, H. Modern Power Gas Producer Practice and Applica- tions.....	12mo,	*2 50
Anderson, J. W. Prospector's Handbook.....	12mo,	1 50
Andes, L. Vegetable Fats and Oils.....	8vo,	*4 00
— Animal Fats and Oils. Trans. by C. Salter.....	8vo,	*4 00
— Drying Oils, Boiled Oil, and Solid and Liquid Driers...	8vo,	*5 00
— Iron Corrosion, Anti-fouling and Anti-corrosive Paints. Trans. by C. Salter.....	8vo,	*4 00
— Oil Colors and Printers' Ink. Trans. by A. Morris and H. Robson.....	8vo,	*2 50
— Treatment of Paper for Special Purposes. Trans. by C. Salter.....	12mo,	*2 50
Andrews, E. S. Reinforced Concrete Construction....	12mo,	*1 25
— Theory and Design of Structures.....	8vo,	3 50
— Further Problems in the Theory and Design of Struc- tures	8vo,	2 50
— The Strength of Materials.....	8vo,	*4 00
Andrews, E. S., and Heywood, H. B. The Calculus for Engineers	12mo,	1 25
Annual Reports on the Progress of Chemistry. Twelve Vol- umes now ready. Vol. I, 1904, to Vol. XII, 1914, 8vo, each.....		*2 00
Argand, M. Imaginary Quantities. Translated from the French by A. S. Hardy. (Science Series No. 52.).....	16mo,	0 50
Armstrong, R., and Idell, F. E. Chimneys for Furnaces and Steam Boilers. (Science Series No. 1.).....	16mo,	0 50
Arnold, E. Armature Windings of Direct Current Dynamos. Trans. by F. B. DeGress.....	8vo,	*2 00
Asch, W., and Asch, D. The Silicates in Chemistry and Commerce	8vo,	*6 00
Ashe, S. W., and Keiley, J. D. Electric Railways. Theoretic- ally and Practically Treated. Vol. I. Rolling Stock 12mo,		*2 50

4 D. VAN NOSTRAND COMPANY'S SHORT-TITLE CATALOG

Ashe, S. W. Electric Railways. Vol. II. Engineering Preliminaries and Direct Current Sub-Stations.....	12mo,	*2 50
—— Electricity: Experimentally and Practically Applied.	12mo,	*2 00
Ashley, R. H. Chemical Calculations.....	12mo,	*2 00
Atkins, W. Common Battery Telephony Simplified....	12mo,	*1 25
Atkinson, A. A. Electrical and Magnetic Calculations..	8vo,	*1 50
Atkinson, J. J. Friction of Air in Mines. (Science Series No. 14.).....	16mo,	0 50
Atkinson, J. J., and Williams, E. H., Jr. Gases Met with in Coal Mines. (Science Series No. 13.).....	16mo,	0 50
Atkinson, P. The Elements of Electric Lighting.....	12mo,	1 00
—— The Elements of Dynamic Electricity and Magnetism.	12mo,	2 00
Atkinson, P. Power Transmitted by Electricity.	12mo,	2 00
Auchincloss, W. S. Link and Valve Motions Simplified....	8vo,	*1 50
Austin, E. Single Phase Electric Railways.....	4to,	*5 00
Ayrton, H. The Electric Arc.....	8vo,	*5 00
Bacon, F. W. Treatise on the Richards Steam-Engine Indicator.....	12mo,	1 00
Bailes, G. M. Modern Mining Practice. Five Volumes.	8vo, each,	3 50
Bailey, R. D. The Brewers' Analyst.....	8vo,	*5 00
Baker, A. L. Quaternions.....	8vo,	*1 25
—— Thick-Lens Optics.....	12mo,	*1 50
Baker, Benj. Pressure of Earthwork. (Science Series No. 56.)	16mo,	
Baker, G. S. Ship Form, Resistance and Screw Propulsion,	8vo,	*4 50
Baker, I. O. Levelling. (Science Series No. 91.).....	16mo,	0 50
Baker, M. N. Potable Water. (Science Series No. 61.)	16mo,	0 50
—— Sewerage and Sewage Purification. (Science Series No. 18.)	16mo,	0 50
Baker, T. T. Telegraphic Transmission of Photographs.	12mo,	*1 25
Bale, G. R. Modern Iron Foundry Practice. Two Volumes.	12mo.	
Vol. I. Foundry Equipment, Material Used.....		*2 50
Vol. II. Machine Moulding and Moulding Machines.....		*1 50

Ball, J. W. Concrete Structures in Railways.....	8vo,	*2 50
Ball, R. S. Popular Guide to the Heavens.....	8vo,	*4 50
— Natural Sources of Power. (Westminster Series)....	8vo,	*2 00
Ball, W. V. Law Affecting Engineers.....	8vo,	*3 50
Bankson, Lloyd. Slide Valve Diagrams. (Science Series No. 108.).....	16mo,	0 50
Barba, J. Use of Steel for Constructive Purposes.....	12mo,	1 00
Barham, G. B. Development of the Incandescent Electric Lamp	8vo	*2 00
Barker, A. F. Textiles and Their Manufacture. (Westminster Series).....	8vo,	2 00
Barker, A. F., and Midgley, E. Analysis of Textile Fabrics,	8vo,	3 00
Barker, A. H. Graphic Methods of Engine Design....	12mo,	*1 50
— Heating and Ventilation.....	4to,	*8 00
Barnard, J. H. The Naval Militiaman's Guide. .	16mo, leather,	1 00
Barnard, Major J. G. Rotary Motion. (Science Series No. 90.)	16mo,	0 50
Barrus, G. H. Boiler Tests.....	8vo,	*3 00
— Engine Tests.....	8vo,	*4 00
The above two purchased together.....		*6 00
Barwise, S. The Purification of Sewage.....	12mo,	3 50
Baterden, J. R. Timber. (Westminster Series).....	8vo,	*2 00
Bates, E. L., and Charlesworth, F. Practical Mathematics and Geometry	12mo,	
Part I. Preliminary and Elementary Course.....		*1 50
Part II. Advanced Course.....		*1 50
— Practical Mathematics.....	12mo,	*1 50
— Practical Geometry and Graphics.....	12mo,	*2 00
Batey, J. The Science of Works Management.....	12mo,	*1 25
— Steam Boilers and Combustion.....	12mo,	*1 25
Beadle, C. Chapters on Papermaking. Five Volumes. 12mo, each,		*2 00
Beaumont, R. Color in Woven Design.....	8vo,	*6 00
— Finishing of Textile Fabrics.....	8vo,	*4 00
— Standard Cloths.....	8vo,	*5 00
Beaumont, W. W. Steam-Engine Indicator.....	8vo,	2 50

Bechhold, H. Colloids in Biology and Medicine. Trans. by J. G. Bullowa.....		(<i>In Press.</i>)
Beckwith, A. Pottery.....	8vo, paper,	0 60
Bedell, F., and Pierce, C. A. Direct and Alternating Current Manual.....	8vo,	*2 00
Beech, F. Dyeing of Cotton Fabrics.....	8vo,	*3 00
— Dyeing of Woolen Fabrics.....	8vo,	*3 50
Beggs, G. E. Stresses in Railway Girders and Bridges....		(<i>In Press.</i>)
Begtrup, J. The Slide Valve.....	8vo,	*2 00
Bender, C. E. Continuous Bridges. (Science Series No. 26.)	16mo,	0 50
— Proportions of Pins used in Bridges. (Science Series No. 4.)	16mo,	0 50
Bengough, G. D. Brass. (Metallurgy Series).....		(<i>In Press.</i>)
Bennett, H.G. The Manufacture of Leather.....	8vo,	*4 50
Bernthsen, A. A Text-book of Organic Chemistry. Trans. by G. M'Gowan.....	12mo,	*2 50
Bersch, J. Manufacture of Mineral and Lake Pigments. Trans. by A. C. Wright.....	8vo,	*5 00
Bertin, L. E. Marine Boilers. Trans. by L. S. Robertson..	8vo,	5 00
Beveridge, J. Papermaker's Pocket Book....	12mo,	*4 00
Binnie, Sir A. Rainfall Reservoirs and Water Supply..	8vo,	*3 00
Binns, C. F. Manual of Practical Potting.....	8vo,	*7 50
— The Potter's Craft.....	12mo,	*2 00
Birchmore, W. H. Interpretation of Gas Analysis....	12mo,	*1 25
Blaine, R. G. The Calculus and Its Applications.....	12mo,	*1 50
Blake, W. H. Brewer's Vade Mecum.....	8vo,	*4 00
Blasdale, W. C. Quantitative Chemical Analysis. (Van Nostrand's Textbooks).....	12mo,	*2 50
Bligh, W. G. The Practical Design of Irrigation Works..	8vo,	*6 00
Bloch, L. Science of Illumination. (Trans. by W. C. Clinton)	8vo,	*2 50
Blok, A. Illumination and Artificial Lighting.....	12mo,	*1 25
Blucher, H. Modern Industrial Chemistry. Trans. by J. P. Millington	8vo,	*7 50
Blyth, A. W. Foods: Their Composition and Analysis...	8vo,	7 50
— Poisons: Their Effects and Detection.....	8vo,	7 50

Böckmann, F. Celluloid.....	12mo,	*2 50
Bodmer, G. R. Hydraulic Motors and Turbines.....	12mo,	5 00
Boileau, J. T. Traverse Tables.....	8vo,	5 00
Bonney, G. E. The Electro-plater's Handbook.....	12mo,	1 20
Booth, N. Guide to Ring-Spinning Frame.....	12mo,	*1 25
Booth, W. H. Water Softening and Treatment.....	8vo,	*2 50
— Superheaters and Superheating and their Control...	8vo,	*1 50
Bottcher, A. Cranes: Their Construction, Mechanical Equip- ment and Working. Trans. by A. Tolhausen....	4to,	*10 00
Bottler, M. Modern Bleaching Agents. Trans. by C. Salter.	12mo,	*2 50
Bottone, S. R. Magnetos for Automobilists.....	12mo,	*1 00
Boulton, S. B. Preservation of Timber. (Science Series No. 82.)	16mo,	0 50
Bourcart, E. Insecticides, Fungicides and Weedkillers...	8vo,	*4 50
Bourgougnon, A. Physical Problems. (Science Series No. 113.)	16mo,	0 50
Bourry, E. Treatise on Ceramic Industries. Trans. by A. B. Searle	8vo,	*5 00
Bowie, A. J., Jr. A Practical Treatise on Hydraulic Mining.	8vo,	5 00
Bowles, O. Tables of Common Rocks. (Science Series, No. 125)	16mo,	0 50
Bowser, E. A. Elementary Treatise on Analytic Geometry.	12mo,	1 75
— Elementary Treatise on the Differential and Integral Calculus	12mo,	2 25
Bowser, E. A. Elementary Treatise on Analytic Mechanics,	12mo,	3 00
— Elementary Treatise on Hydro-mechanics.....	12mo,	2 50
— A Treatise on Roofs and Bridges.....	12mo,	*2 25
Boycott, G. W. M. Compressed Air Work and Diving.	8vo,	*4 00
Bragg, E. M. Marine Engine Design.....	12mo,	*2 00
— Design of Marine Engines and Auxiliaries.....		*3 00
Brainard, F. R. The Sextant. (Science Series No. 101.)	16mo,	
Brassey's Naval Annual for 1915. War Edition.....	8vo,	4 00
Briggs, R., and Wolff, A. R. Steam-Heating. (Science Series No. 67.)	16mo,	0 50

Bright, C. The Life Story of Sir Charles Tilson Bright. .8vo,	*4	50
Brislee, T. J. Introduction to the Study of Fuel. (Outlines of Industrial Chemistry.)8vo,	*3	00
Broadfoot, S. K. Motors Secondary Batteries. (Installation Manuals Series.)12mo,	*0	75
Broughton, H. H. Electric Cranes and Hoists.	*9	00
Brown, G. Healthy Foundations. (Science Series No. 80.) .16mo,	0	50
Brown, H. Irrigation.8vo,	*5	00
Brown, H. Rubber.8vo,	*2	00
Brown, Wm. N. The Art of Enamelling on Metal.12mo,	*1	00
— Handbook on Japanning.12mo,	*1	50
— House Decorating and Painting.12mo,	*1	50
— History of Decorative Art.12mo,	*1	25
— Dipping, Burnishing, Lacquering and Bronzing Brass Ware12mo,	*1	00
— Workshop Wrinkles8vo,	*1	00
Browne, C. L. Fitting and Erecting of Engines.8vo,	*1	50
Browne, R. E. Water Meters. (Science Series No. 81.) .16mo,	0	50
Bruce, E. M. Pure Food Tests.12mo,	*1	25
Bruhns, Dr. New Manual of Logarithms.8vo, cloth,	2	00
Half morocco,	2	50
Brunner, R. Manufacture of Lubricants, Shoe Polishes and Leather Dressings. Trans. by C. Salter.8vo,	*3	00
Buel, R. H. Safety Valves. (Science Series No. 21.) . .16mo,	0	50
Burley, G. W. Lathes, Their Construction and Operation,12mo,	1	25
Burnside, W. Bridge Foundations.12mo,	*1	25
Burstall, F. W. Energy Diagram for Gas. With text. .8vo,	1	50
— Diagram sold separately.	*1	00
Burt, W. A. Key to the Solar Compass.16mo, leather,	2	50
Buskett, E. W. Fire Assaying.12mo,	*1	25
Butler, H. J. Motor Bodies and Chasis.8vo,	*2	50
Byers, H. G., and Knight, H. G. Notes on Qualitative Analysis8vo,	*1	50

Cain, W. Brief Course in the Calculus.....	12m0,	*1 75
— Elastic Arches. (Science Series No. 48.).....	16m0,	0 50
— Maximum Stresses. (Science Series No. 38.).....	16m0,	0 50
— Practical Designing Retaining of Walls. (Science Series No. 3.)	16m0,	0 50
— Theory of Steel-concrete Arches and of Vaulted Struc- tures. (Science Series, No. 42).....	16m0,	0 50
— Theory of Voussoir Arches. (Science Series No. 12.)	16m0,	0 50
— Symbolic Algebra. (Science Series No. 73.).....	16m0,	0 50
Carpenter, F. D. Geographical Surveying. (Science Series No. 37.)	16m0,	
Carpenter, R. C., and Diederichs, H. Internal-Combustion Engines8v0,	*5 00
Carter, H. A. Ramie (Rhea), China Grass.....	12m0,	*2 00
Carter, H. R. Modern Flax, Hemp, and Jute Spinning...8v0,		*3 00
— Bleaching, Dyeing and Finishing of Fabrics.....	.8v0,	*1 00
Cary, E. R. Solution of Railroad Problems With the Use of the Slide Rule.....	16m0,	*1 00
Casler, M. D. Simplified Reinforced Concrete Mathematics,	12m0,	*1 00
Cathcart, W. L. Machine Design. Part I. Fastenings...8v0,		*3. 00
Cathcart, W. L., and Chaffee, J. I. Elements of Graphic Statics8v0,	*3 00
— Short Course in Graphics.....	12m0,	1 50
Caven, R. M., and Lander, G. D. Systematic Inorganic Chem- istry	12m0,	*2 00
Chalkley, A. P. Diesel Engines.....	.8v0,	*3 50
Chambers' Mathematical Tables.....	.8v0,	1 75
Chambers, G. F. Astronomy.....	16m0,	*1 50
Chappel, E. Five Figure Mathematical Tables.....	.8v0,	*2 00
Charnock. Mechanical Technology.....	.8v0,	*3 00
Charpentier, P. Timber.....	.8v0,	*6 00
Chatley, H. Principles and Designs of Aeroplanes. (Science Series.)	16m0,	0 50
— How to Use Water Power.....	12m0,	*1 00
— Gyrostatic Balancing.....	.8v0,	*1 00

10 D. VAN NOSTRAND COMPANY'S SHORT-TITLE CATALOG

Child, C. D. Electric Arcs.....	8vo,	*2 00
Christian, M. Disinfection and Disinfectants. Trans. by Chas. Salter	12mo,	2 00
Christie, W. W. Boiler-waters, Scale, Corrosion, Foaming,	8vo,	*3 00
— Chimney Design and Theory.....	8vo,	*3 00
— Furnace Draft. (Science Series, No. 123).....	16mo,	0 50
— Water, Its Purification and Use in the Industries....	8vo,	*2 00
Church's Laboratory Guide. Rewritten by Edward Kinch.	8vo,	*2 50
Clapperton, G. Practical Papermaking.....	8vo,	2 50
Clark, A. G. Motor Car Engineering.		
Vol. I. Construction.....		*3 00
Vol. II. Design.....		(In Press.)
Clark, C. H. Marine Gas Engines.....	12mo,	*1 50
Clark, J. M. New System of Laying Out Railway Turnouts,	12mo,	1 00
Clarke, J. W., and Scott, W. Plumbing Practice.		
Vol. I. Lead Working and Plumbers' Materials..	8vo,	*4 00
Vol. II. Sanitary Plumbing and Fittings.....		(In Press.)
Vol. III. Practical Lead Working on Roofs.....		(In Press.)
Clarkson, R. B. Elementary Electrical Engineering.		(In Press.)
Clausen-Thue, W. A B C Universal Commercial Telegraphic Code. Sixth Edition.....		(In Press.)
Clerk, D., and Idell, F. E. Theory of the Gas Engine. (Science Series No. 62.).....	16mo,	0 50
Clevenger, S. R. Treatise on the Method of Government Surveying	16mo, mor.,	2 50
Clouth, F. Rubber, Gutta-Percha, and Balata.....	8vo,	*5 00
Cochran, J. Treatise on Cement Specifications.....	8vo,	*1 00
— Concrete and Reinforced Concrete Specifications....	8vo,	*2 50
Cochran, J. Inspection of Concrete Construction.....	8vo,	*4 00
Coffin, J. H. C. Navigation and Nautical Astronomy..	12mo,	*3 50
Colburn, Z., and Thurston, R. H. Steam Boiler Explosions. (Science Series No. 2.).....	16mo,	0 50
Cole, R. S. Treatise on Photographic Optics.....	12mo,	1 50

D. VAN NOSTRAND COMPANY'S SHORT-TITLE CATALOG 11

Coles-Finch, W. Water, Its Origin and Use.....	8vo,	*5 00
Collins, J. E. Useful Alloys and Memoranda for Goldsmiths, Jewelers.....	16mo,	0 50
Collis, A. G. High and Low Tension Switch-Gear Design.	8vo,	*3 50
— Switchgear. (Installation Manuals Series.).....	12mo,	0 50
Comstock, D. F., and Troland, L. T. The Nature of Matter and Electricity.....	<i>(In Press.)</i>	
Coombs, H. A. Gear Teeth. (Science Series No. 120)...	16mo,	0 50
Cooper, W. R. Primary Batteries.....	8vo,	*4 00
Copperthwaite, W. C. Tunnel Shields.....	4to,	*9 00
Corfield, W. H. Dwelling Houses. (Science Series No. 50.)	16mo,	0 50
— Water and Water-Supply. (Science Series No. 17.)	16mo,	0 50
Cornwall, H. B. Manual of Blow-pipe Analysis.....	8vo,	*2 50
Cowee, G. A. Practical Safety Methods and Devices...	8vo,	*3 00
Cowell, W. B. Pure Air, Ozone, and Water.....	12mo,	*2 00
Craig, J. W., and Woodward, W. P. Questions and Answers about Electrical Apparatus.....	12mo, leather,	1 50
Craig, T. Motion of a Solid in a Fuel. (Science Series No. 49.)	16mo,	0 50
— Wave and Vortex Motion. (Science Series No. 43.)	16mo,	0 50
Cramp, W. Continuous Current Machine Design.....	8vo,	*2 50
Creedy, F. Single-Phase Commutator Motors.....	8vo,	*2 00
Crocker, F. B. Electric Lighting. Two Volumes. 8vo.		
Vol. I. The Generating Plant.....		3 00
Vol. II. Distributing Systems and Lamps.....		
Crocker, F. B., and Arendt, M. Electric Motors.....	8vo,	*2 50
— and Wheeler, S. S. The Management of Electrical Ma- chinery.....	12mo,	*1 00
Cross, C. F., Bevan, E. J., and Sindall, R. W. Wood Pulp and Its Applications. (Westminster Series.).....	8vo,	*2 00
Crosskey, L. R. Elementary Perspective.....	8vo,	1 00
Crosskey, L. R., and Thaw, J. Advanced Perspective.....	8vo,	1 50
Culley, J. L. Theory of Arches. (Science Series No. 87.)	16mo,	0 50
Cushing, H. C., Jr., and Harrison, N. Central Station Man- agement.....		*2 00
Dadourian, H. M. Analytical Mechanics.....	8vo,	*3 00

12 D. VAN NOSTRAND COMPANY'S SHORT-TITLE CATALOG

Dana, R. T. Handbook of Construction Plant.	12mo, leather,	*5 00
— Handbook of Construction Efficiency.	(<i>In Press.</i>)	
Danby, A. Natural Rock Asphalts and Bitumens.	8vo,	*2 50
Davenport, C. The Book. (Westminster Series.)	8vo,	*2 00
Davey, N. The Gas Turbine.	8vo,	*4 00
Davies, F. H. Electric Power and Traction.	8vo,	*2 00
— Foundations and Machinery Fixing. (Installation Manuals Series)	16mo,	*1 00
Deerr, N. Sugar Cane.	8vo,	7 00
Deite, C. Manual of Soapmaking. Trans. by S. T. King.	4to,	*5 00
De la Coux, H. The Industrial Uses of Water. Trans. by A. Morris.	8vo,	*4 50
Del Mar, W. A. Electric Power Conductors.	8vo,	*2 00
Denny, G. A. Deep-Level Mines of the Rand.	4to,	*10 00
— Diamond Drilling for Gold.		*5 00
De Roos, J. D. C. Linkages. (Science Series No. 47.)	16mo,	0 50
Derr, W. L. Block Signal Operation.	Oblong 12mo,	*1 50
— Maintenance of Way Engineering.	(<i>In Preparation.</i>)	
Desaint, A. Three Hundred Shades and How to Mix Them.	8vo,	8 00
De Varona, A. Sewer Gases. (Science Series No. 55.)	16mo,	0 50
Devey, R. G. Mill and Factory Wiring. (Installation Manuals Series.)	12mo,	*1 00
Dibdin, W. J. Purification of Sewage and Water.	8vo,	6 50
Dichman, C. Basic Open-Hearth Steel Process.	8vo,	*3 50
Dieterich, K. Analysis of Resins, Balsams, and Gum Resins.	8vo,	*3 00
Dilworth, E. C. Steel Railway Bridges.	4to,	*4 00
Dinger, Lieut. H. C. Care and Operation of Naval Machinery.	12mo.	*2 00
Dixon, D. B. Machinist's and Steam Engineer's Practical Calculator.	16mo, mor.,	1 25
Dodge, G. F. Diagrams for Designing Reinforced Concrete Structures.	folio,	*4 00
Dommett, W. E. Motor Car Mechanism.	12mo,	*1 25
Dorr, B. F. The Surveyor's Guide and Pocket Table-book.	16mo, mor.,	2 00

D. VAN NOSTRAND COMPANY'S SHORT-TITLE CATALOG 13

Draper, C. H. Elementary Text-book of Light, Heat and Sound.....	12mo,	1 00
Draper, C. H. Heat and the Principles of Thermo-dynamics,	12mo,	2 00
Dron, R. W. Mining Formulas.....	12mo,	1 00
Dubbel, H. High Power Gas Engines.....	8vo,	*5 00
Dumesny, P., and Noyer, J. Wood Products, Distillates, and Extracts.....	8vo,	*4 50
Duncan, W. G., and Penman, D. The Electrical Equipment of Collieries.....	8vo,	*4 00
Dunstan, A. E., and Thole, F. B. T. Textbook of Practical Chemistry.....	12mo,	*1 40
Duthie, A. L. Decorative Glass Processes. (Westminster Series).....	8vo,	*2 00
Dwight, H. B. Transmission Line Formulas.....	8vo	*2 00
Dyson, S. S. Practical Testing of Raw Materials.....	8vo,	*5 00
— and Clarkson, S. S. Chemical Works.....	8vo,	*7 50
Eccles, W. H. Wireless Telegraphy and Telephony..	12mo,	*4 50
Eck, J. Light, Radiation and Illumination. Trans. by Paul Hogner	8vo,	*2 50
Eddy, H. T. Maximum Stresses under Concentrated Loads,	8vo,	1 50
Eddy, L. C. Laboratory Manual of Alternating Currents,	12mo,	0 50
Edelman, P. Inventions and Patents.....	12mo	*1 50
Edgcombe, K. Industrial Electrical Measuring Instruments.	8vo.	
Eidler, R. Switches and Switchgear. Trans. by Ph. Laubach.	8vo,	*4 00
Eissler, M. The Metallurgy of Gold.....	8vo,	7 50
— The Metallurgy of Silver.....	8vo,	4 00
— The Metallurgy of Argentiferous Lead.....	8vo,	5 00
— A Handbook of Modern Explosives.....	8vo,	5 00
Ekin, T. C. Water Pipe and Sewage Discharge Diagrams	folio,	*3 00

14 D. VAN NOSTRAND COMPANY'S SHORT-TITLE CATALOG

Electric Light Carbons, Manufacture of.....	8vo,	1 00
Eliot, C. W., and Storer, F. H. Compendious Manual of Qualita- tive Chemical Analysis.....	12mo,	*1 25
Ellis, C. Hydrogenation of Oils.....	8vo,	
Ellis, G. Modern Technical Drawing.....	8vo,	*2 00
Ennis, Wm. D. Linseed Oil and Other Seed Oils	8vo,	*4 00
— Applied Thermodynamics.....	8vo,	*4 50
— Flying Machines To-day.....	12mo,	*1 50
— Vapors for Heat Engines.....	12mo,	*1 00
Ermen, W. F. A. Materials Used in Sizing.....	8vo,	*2 00
Erwin, M. The Universe and the Atom.....	12mo,	*2 00
Evans, C. A. Macadamized Roads.....	(In Press.)	
Ewing, A. J. Magnetic Induction in Iron.....	8vo,	*4 00
Fairie, J. Notes on Lead Ores.....	12mo,	*1 00
— Notes on Pottery Clays.....	12mo,	*1 50
Fairley, W., and Andre, Geo. J. Ventilation of Coal Mines. (Science Series No. 58.).....	16mo,	0 50
Fairweather, W. C. Foreign and Colonial Patent Laws ..	8vo,	*3 00
Falk, M. S. Cement Mortars and Concretes.....	8vo,	*2 50
Fanning, J. T. Hydraulic and Water-supply Engineering.	8vo,	*5 00
Fay, I. W. The Coal-tar Colors.....	8vo,	*4 00
Fernbach, R. L. Glue and Gelatine.....	8vo,	*3 00
— Chemical Aspects of Silk Manufacture.....	12mo,	*1 00
Firth, J. B. Practical Physical Chemistry.....	12mo,	*1 00
Fischer, E. The Preparation of Organic Compounds. Trans. by R. V. Stanford.....	12mo,	*1 25
Fish, J. C. L. Lettering of Working Drawings....	Oblong 8vo,	1 00
— Mathematics of the Paper Location of a Railroad, 12mo, paper,		*0 25
Fisher, H. K. C., and Darby, W. C. Submarine Cable Testing, 8vo,		*3 50
Fleischmann, W. The Book of the Dairy. Trans. by C. M. Aikman.....	8vo,	4 00
Fleming, J. A. The Alternate-current Transformer. Two Volumes.....	8vo,	
Vol. I. The Induction of Electric Currents.....		*5 00
Vol. II. The Utilization of Induced Currents		*5 00

D. VAN NOSTRAND COMPANY'S SHORT-TITLE CATALOG 15

Fleming, J. A. Propagation of Electric Currents.....	8vo,	*3 00
— A Handbook for the Electrical Laboratory and Testing Room. Two Volumes.....	8vo, each,	*5 00
Fleury, P. Preparation and Uses of White Zinc Paints..	8vo,	*2 50
Flynn, P. J. Flow of Water. (Science Series No. 84.)..	12mo,	0 50
— Hydraulic Tables. (Science Series No. 66.).....	16mo,	0 50
Forgie, J. Shield Tunneling.....	8vo. (<i>In Press.</i>)	
Foster, H. A. Electrical Engineers' Pocket-book. (<i>Seventh Edition.</i>).....	12mo, leather,	5 00
— Engineering Valuation of Public Utilities and Factories, 8vo,		*3 00
— Handbook of Electrical Cost Data.....	8vo. (<i>In Press</i>)	
Fowle, F. F. Overhead Transmission Line Crossings....	12mo,	*1 50
— The Solution of Alternating Current Problems.....	8vo (<i>In Press.</i>)	
Fox, W. G. Transition Curves. (Science Series No. 110.)..	16mo,	0 50
Fox, W., and Thomas, C. W. Practical Course in Mechanical Drawing.....	12mo,	1 25
Foye, J. C. Chemical Problems. (Science Series No. 69.)..	16mo,	0 50
— Handbook of Mineralogy. (Science Series No. 86.)..	16mo,	0 50
Francis, J. B. Lowell Hydraulic Experiments.....	4to,	15 00
Franzen, H. Exercises in Gas Analysis.....	12mo,	*1 00
French, J. W. Machine Tools. 2 vols.....	4to,	*15 00
Freudemacher, P. W. Electrical Mining Installations. (<i>In- stallation Manuals Series.</i>).....	12mo,	*1 00
Frith, J. Alternating Current Design.....	8vo,	*2 00
Fritsch, J. Manufacture of Chemical Manures. Trans. by D. Grant.....	8vo,	*4 00
Frye, A. I. Civil Engineers' Pocket-book.....	12mo, leather,	*5 00
Fuller, G. W. Investigations into the Purification of the Ohio River.....	4to,	*10 00
Furnell, J. Paints, Colors, Oils, and Varnishes.....	8vo,	*1 00
Gairdner, J. W. I. Earthwork.....	8vo (<i>In Press.</i>)	
Gant, L. W. Elements of Electric Traction.....	8vo,	*2 50
Garcia, A. J. R. V. Spanish-English Railway Terms....	8vo,	*4 50

16 D. VAN NOSTRAND COMPANY'S SHORT-TITLE CATALOG

Garforth, W. E. Rules for Recovering Coal Mines after Explosions and Fires.....	12mo, leather,	1 50
Garrard, C. C. Electric Switch and Controlling Gear.... (<i>In Press.</i>)		
Gaudard, J. Foundations. (Science Series No. 34.)....	16mo,	0 50
Gear, H. B., and Williams, P. F. Electric Central Station Distributing Systems.....	8vo,	3 00
Geerligs, H. C. P. Cane Sugar and Its Manufacture	8vo,	*5 00
Geikie, J. Structural and Field Geology.....	8vo,	*4 00
— Mountains, Their Origin, Growth and Decay.....	8vo,	*4 00
— The Antiquity of Man in Europe.....	8vo,	*3 00
Georgi, F., and Schubert, A. Sheet Metal Working. Trans. by C. Salter.....	8vo,	3 00
Gerhard, W. P. Sanitation, Water-supply and Sewage Disposal of Country Houses.....	12mo,	*2 00
— Gas Lighting. (Science Series No. 111.).....	16mo,	0 50
Gerhard, W. P. Household Wastes. (Science Series No. 97.)	16mo,	0 50
— House Drainage. (Science Series No. 63.).....	16mo,	0 50
— Sanitary Drainage of Buildings. (Science Series No. 93.)	16mo,	0 50
Gerhardi, C. W. H. Electricity Meters.....	8vo,	*4 00
Geschwind, L. Manufacture of Alum and Sulphates. Trans. by C. Salter.....	8vo,	*5 00
Gibbings, A. H. Oil Fuel Equipment for Locomotives... 8vo,		*2 50
Gibbs, W. E. Lighting by Acetylene.....	12mo,	*1 50
Gibson, A. H. Hydraulics and Its Application.....	8vo,	*5 00
— Water Hammer in Hydraulic Pipe Lines.....	12mo,	*2 00
Gibson, A. H., and Ritchie, E. G. Circular Arc Bow Girder. 4to,		*3 50
Gilbreth, F. B. Motion Study.....	12mo,	*2 00
— Bricklaying System.....	8vo,	*3 00
— Field System.....	12mo, leather,	*3 00
— Primer of Scientific Management.....	12mo,	*1 00
Gillette, H. P. Handbook of Cost Data.....	12mo, leather,	*5 00
— Rock Excavation Methods and Cost....	12mo, leather,	*5 00
— Handbook of Earth Excavation..... (<i>In Press.</i>)		
— Handbook of Tunnels and Shafts, Cost and Methods of Construction..... (<i>In Press.</i>)		
— Handbook of Road Construction, Methods and Cost.. (<i>In Press.</i>)		

D. VAN NOSTRAND COMPANY'S SHORT-TITLE CATALOG 17

Gillette, H. P., and Dana, R. T. Cost Keeping and Management Engineering	8vo,	*3 50
— and Hill, C. S. Concrete Construction, Methods and Cost	8vo,	*5 00
Gillmore, Gen. Q. A. Limes, Hydraulics Cement and Mortars.	8vo,	4 00
— Roads, Streets, and Pavements	12mo,	2 00
Godfrey, E. Tables for Structural Engineers..	16mo, leather,	*2 50
Golding, H. A. The Theta-Phi Diagram	12mo,	*1 25
Goldschmidt, R. Alternating Current Commutator Motor.	8vo,	*3 00
Goodchild, W. Precious Stones. (Westminster Series.)	8vo,	*2 00
Goodeve, T. M. Textbook on the Steam-engine	12mo,	2 00
Gore, G. Electrolytic Separation of Metals	8vo,	*3 50
Gould, E. S. Arithmetic of the Steam-engine	12mo,	1 00
— Calculus. (Science Series No. 112.)	16mo,	0 50
— High Masonry Dams. (Science Series No. 22.) ..	16mo,	0 50
— Practical Hydrostatics and Hydrostatic Formulas. (Science Series No. 117.)	16mo,	0 50
Gratacap, L. P. A Popular Guide to Minerals	8vo,	*3 00
Gray, J. Electrical Influence Machines	12mo,	2 00
Gray, J. Marine Boiler Design	12mo,	*1 25
Greenhill, G. Dynamics of Mechanical Flight	8vo.	*2 50
Greenwood, E. Classified Guide to Technical and Commercial Books	8vo,	*3 00
Gregorius, R. Mineral Waxes. Trans. by C. Salter ..	12mo,	*3 00
Grierson, R. Modern Methods of Ventilation.	(In Press.)	
Griffiths, A. B. A Treatise on Manures	12mo,	3 00
Griffiths, A. B. Dental Metallurgy	8vo,	*3 50
Gross, E. Hops	8vo,	*4 50
Grossman, J. Ammonia and its Compounds	12mo,	*1 25
Groth, L. A. Welding and Cutting Metals by Gases or Electricity. (Westminster Series.)	8vo,	*2 00
Grover, F. Modern Gas and Oil Engines	8vo,	*2 00
Gruner, A. Power-loom Weaving	8vo,	*3 00
Güldner, Hugo. Internal-Combustion Engines. Trans. by H. Diedrichs	4to,	*10 00

18 D. VAN NOSTRAND COMPANY'S SHORT-TITLE CATALOG

Gunther, C. O. Integration.....	8vo,	*1 25
Gurden, R. L. Traverse Tables.....	folio, half mor.,	*7 50
Guy, A. E. Experiments on the Flexure of Beams.....	8vo,	*1 25
Haenig, A. Emery and the Emery Industry.....	8vo,	*2 50
Hainbach, R. Pottery Decoration. Trans. by C. Salter.	12mo,	*3 00
Hale, W. J. Calculations of General Chemistry.....	12mo,	*1 00
Hall, C. H. Chemistry of Paints and Paint Vehicles....	12mo,	*2 00
Hall, G. L. Elementary Theory of Alternate Current Work- ing	8vo,	*1 50
Hall, R. H. Governors and Governing Mechanism.....	12mo,	*2 00
Hall, W. S. Elements of the Differential and Integral Calculus	8vo,	*2 25
— Descriptive Geometry	8vo volume and 4to atlas,	*3 50
Haller, G. F., and Cunningham, E. T. The Tesla Coil.....	12mo,	*1 25
Halsey, F. A. Slide Valve Gears.....	12mo,	1 50
— The Use of the Slide Rule. (Science Series No. 114.)	16mo,	0 50
— Worm and Spiral Gearing. (Science Series No. 116.)	16mo,	0 50
Hancock, H. Textbook of Mechanics and Hydrostatics....	8vo,	1 50
Hancock, W. C. Refractory Materials. (Metallurgy Series. <i>In Press.</i>)		
Hardy, E. Elementary Principles of Graphic Statics....	12mo,	*1 50
Haring, H. Engineering Law. Vol. I. Law of Contract.....	8vo,	*4 00
Harper, J. H. Hydraulic Tables on the Flow of Water.	16mo,	*2 00
Harris, S. M. Practical Topographical Surveying.	(<i>In Press.</i>)	
Harrison, W. B. The Mechanics' Tool-book.....	12mo,	1 50
Hart, J. W. External Plumbing Work.....	8vo,	*3 00
— Hints to Plumbers on Joint Wiping.....	8vo,	*3 00
— Principles of Hot Water Supply.....	8vo,	*3 00
— Sanitary Plumbing and Drainage.....	8vo,	*3 00
Haskins, C. H. The Galvanometer and Its Uses.....	16mo,	1 50
Hatt, J. A. H. The Colorist.....	square 12mo,	*1 50
Hausbrand, E. Drying by Means of Air and Steam. Trans. by A. C. Wright.....	12mo,	*2 00
— Evaporating, Condensing and Cooling Apparatus. Trans. by A. C. Wright.....	8vo,	*5 00

D. VAN NOSTRAND COMPANY'S SHORT-TITLE CATALOG 19

Hausmann, E. Telegraph Engineering.....	8vo,	*3 00
Hausner, A. Manufacture of Preserved Foods and Sweetmeats. Trans. by A. Morris and H. Robson.....	8vo,	*3 00
Hawkesworth, J. Graphical Handbook for Reinforced Concrete Design.....	4to,	*2 50
Hay, A. Continuous Current Engineering.....	8vo,	*2 50
Hayes, H. V. Public Utilities, Their Cost New and Deprecia- tion.....	8vo,	*2 00
— Public Utilities, Their Fair Present Value and Return, 8vo,		*2 00
Heath, F. H. Chemistry of Photography.....	8vo (<i>In Press.</i>)	
Heather, H. J. S. Electrical Engineering.....	8vo,	*3 50
Heaviside, O. Electromagnetic Theory. Vols. I and II.....	8vo, each,	*5 00
Vol. III.....	8vo,	*7 50
Heck, R. C. H. Steam Engine and Turbine.....	8vo,	*3 50
— Steam-Engine and Other Steam Motors. Two Volumes. Vol. I. Thermodynamics and the Mechanics.....	8vo,	*3 50
Vol. II. Form, Construction and Working.....	8vo,	*5 00
— Notes on Elementary Kinematics.....	8vo, boards,	*1 00
— Graphics of Machine Forces.....	8vo, boards,	*1 00
Heermann, P. Dyers' Materials. Trans. by A. C. Wright. 12mo,		*2 50
Heidenreich, E. L. Engineers' Pocketbook of Reinforced Concrete	16mo, leather,	*3 00
Hellot, Macquer and D'Apligny. Art of Dyeing Wool, Silk and Cotton.....	8vo,	*2 00
Henrici, O. Skeleton Structures.....	8vo,	1 50
Hering, D. W. Essentials of Physics for College Students. 8vo,		*1 75
Hering-Shaw, A. Domestic Sanitation and Plumbing. Two Vols.....	8vo,	*5 00
— Elementary Science.....	8vo,	*2 00
Herington, C. F. Powdered Coal as a Fuel.....	(<i>In Press.</i>)	
Hermann, G. The Graphical Statics of Mechanism. Trans. by A. P. Smith.....	12mo,	2 00
Herzfeld, J. Testing of Yarns and Textile Fabrics.....	8vo,	*3 50

20 D. VAN NOSTRAND COMPANY'S SHORT-TITLE CATALOG

Hildebrandt, A. Airships, Past and Present.....	8vo,	*3 50
Hildenbrand, B. W. Cable-Making. (Science Series No. 32.)	16mo,	0 50
Hilditch, T. P. Concise History of Chemistry.....	12mo,	*1 25
Hill, C. S. Concrete Inspection.....	16mo,	*1 00
Hill, C. W. Laboratory Manual and Notes in Beginning Chemistry	(In Press.)	
Hill, J. W. The Purification of Public Water Supplies. New Edition.....	(In Press.)	
— Interpretation of Water Analysis.....	(In Press.)	
Hill, M. J. M. The Theory of Proportion.....	8vo,	*2 50
Hiroi, I. Plate Girder Construction. (Science Series No. 95.)	16mo,	0 50
— Statically-Indeterminate Stresses.....	12mo,	*2 00
Hirshfeld, C. F. Engineering Thermodynamics. (Science Series No. 45).....	16mo,	0 50
Hoar, A. The Submarine Torpedo Boat.....	12mo,	*2 00
Hobart, H. M. Heavy Electrical Engineering.....	8vo,	*4 50
— Design of Static Transformers.....	12mo,	*2 00
— Electricity.....	8vo,	*2 00
— Electric Trains.....	8vo,	*2 50
— Electric Propulsion of Ships.....	8vo,	*2 00
Hobart, J. F. Hard Soldering, Soft Soldering, and Brazing.	12mo,	*1 00
Hobbs, W. R. P. The Arithmetic of Electrical Measurements	12mo,	0 50
Hoff, J. N. Paint and Varnish Facts and Formulas....	12mo,	*1 50
Hole, W. The Distribution of Gas.....	8vo,	*7 50
Holley, A. L. Railway Practice.....	folio,	6 00
Hopkins, N. M. Model Engines and Small Boats....	12mo,	1 25
Hopkinson, J., Shoolbred, J. N., and Day, R. E. Dynamic Electricity. (Science Series No. 71.).....	16mo,	0 50
Horner, J. Practical Ironfounding.....	8vo,	*2 00
— Gear Cutting, in Theory and Practice.....	8vo,	*3 00
Houghton, C. E. The Elements of Mechanics of Materials.	12mo,	*2 00
Houstoun, R. A. Studies in Light Production.....	12mo,	2 00

Hovenden, F. Practical Mathematics for Young Engineers,	12mo,	*1 00
Howe, G. Mathematics for the Practical Man.....	12mo,	*1 25
Howorth, J. Repairing and Riveting Glass, China and Earthen- ware.....	8vo, paper,	*0 50
Hoyt, W. F. Chemistry by Experimentation.....	(In Press.)	
Hubbard, E. The Utilization of Wood-waste.....	8vo,	*2 00
Hubner, J. Bleaching and Dyeing of Vegetable and Fibrous Materials. (Outlines of Industrial Chemistry.)	8vo,	*5 00
Hudson, O. F. Iron and Steel. (Outlines of Industrial Chemistry.)	8vo,	*2 00
Humphrey, J. C. W. Metallography of Strain. (Metallurgy Series)	(In Press.)	
Humphreys, A. C. The Business Features of Engineering Practice	8vo,	*1 25
Hunter, A. Bridge Work.....	8vo (In Press.)	
Hurst, G. H. Handbook of the Theory of Color.....	8vo,	*2 50
— Dictionary of Chemicals and Raw Products.....	8vo,	*3 00
— Lubricating Oils, Fats and Greases.....	8vo,	*4 00
— Soaps.....	8vo,	*5 00
Hurst, G. H., and Simmons, W. H. Textile Soaps and Oils, 8vo,		3 00
Hurst, H. E., and Lattey, R. T. Text-book of Physics.....	8vo,	*3 00
— Also published in Three Parts:		
Vol. I. Dynamics and Heat.....		*1 25
Vol. II. Sound and Light.....		*1 25
Vol. III. Magnetism and Electricity.....		*1 50
Hutchinson, R. W., Jr. Long Distance Electric Power Trans- mission.....	12mo,	*3 00
Hutchinson, R. W., Jr., and Thomas, W. A. Electricity in Mining	(In Press.)	
Hutchinson, W. B. Patents and How to Make Money Out of Them.....	12mo,	1 25
Hutton, W. S. The Works' Manager's Handbook.....	8vo,	6 00
Hyde, E. W. Skew Arches. (Science Series No. 15.)....	16mo,	0 50
Hyde, F. S. Solvents, Oils, Gums and Waxes.....	8vo,	*2 00

Induction Coils. (Science Series No. 53.).....	16mo,	0 50
Ingham, A. E. Gearing. A practical treatise.....	8vo,	*2 50
Ingle, H. Manual of Agricultural Chemistry.	8vo,	*3 00
Inness, C. H. Problems in Machine Design.....	12mo,	*2 00
— Air Compressors and Blowing Engines.....	12mo,	*2 00
— Centrifugal Pumps.....	12mo,	*2 00
— The Fan.....	12mo,	*2 00
Invatts, E. B. Railway Management at Stations.....	8vo,	*2 50
Jacob, A., and Gould, E. S. On the Designing and Construction of Storage Reservoirs. (Science Series No. 6.)..	16mo,	0 50
Jannettaz, E. Guide to the Determination of Rocks. Trans. by G. W. Plympton.....	12mo,	1 50
Jehl, F. Manufacture of Carbons.....	8vo,	*4 00
Jennings, A. S. Commercial Paints and Painting. (West- minster Series.)	8vo,	*2 00
Jennison, F. H. The Manufacture of Lake Pigments . . .	8vo,	*3 00
Jepson, G. Cams and the Principles of their Construction... — Mechanical Drawing.....	8vo, (In Preparation.)	*1 50
Jervis-Smith, F. J. Dynamometers.....	8vo,	*3 50
Jockin, W. Arithmetic of the Gold and Silversmith . . .	12mo,	*1 00
Johnson, J. H. Arc Lamps and Accessory Apparatus. (In- stallation Manuals Series.).....	12mo,	*0 75
Johnson, T. M. Ship Wiring and Fitting. (Installation Manuals Series.)	12mo,	*0 75
Johnson, W. McA. The Metallurgy of Nickel..... (In Preparation.)		
Johnston, J. F. W., and Cameron, C. Elements of Agricultural Chemistry and Geology.....	12mo,	2 60
Joly, J. Radioactivity and Geology.....	12mo,	*3 00
Jones, H. C. Electrical Nature of Matter and Radioactivity	12mo,	*2 00
— Nature of Solution..... (In Press.)		
— New Era in Chemistry.....	12mo,	*2 00
Jones, J. H. Tinplate Industry.....	8vo,	*3 00
Jones, M. W. Testing Raw Materials Used in Paint....	12mo,	*2 00
Jordan, L. C. Practical Railway Spiral.....	12mo, Leather,	*1 50

Joynson, F. H. Designing and Construction of Machine Gear- ing.....	8vo,	2 00
Jüptner, H. F. V. Siderology: The Science of Iron.....	8vo,	*5 00
Kapp, G. Alternate Current Machinery. (Science Series No. 96.).....	16mo,	0 50
Kapper, F. Overhead Transmission Lines.....	4to,	*4 00
Keim, A. W. Prevention of Dampness in Buildings.....	8vo,	*2 00
Keller, S. S. Mathematics for Engineering Students. 12mo, half leather,		
— Algebra and Trigonometry, with a Chapter on Vectors....		*1 75
— Plane and Solid Geometry.....		*1 25
— and Knox, W. E. Analytical Geometry and Calculus..		*2 00
Kelsey, W. R. Continuous-current Dynamos and Motors. 8vo,		*2 50
Kemble, W. T., and Underhill, C. R. The Periodic Law and the Hydrogen Spectrum.....	8vo, paper,	*0 50
Kemp, J. F. Handbook of Rocks.....	8vo,	*1 50
Kendall, E. Twelve Figure Cipher Code.....	4to,	*12 50
Kennedy, A. B. W., and Thurston, R. H. Kinematics of Machinery. (Science Series No. 54.).....	16mo,	0 50
Kennedy, A. B. W., Unwin, W. C., and Idell, F. E. Compressed Air. (Science Series No. 106.).....	16mo,	0 50
Kennedy, R. Modern Engines and Power Generators. Six Volumes.....	4to,	15 00
Single Volumes.....	each,	3 00
— Electrical Installations. Five Volumes.....	4to,	15 00
Single Volumes.....	each,	3 50
— Flying Machines; Practice and Design.....	12mo,	*2 00
— Principles of Aeroplane Construction.....	8vo,	*1 50
Kennelly, A. E. Electro-dynamic Machinery.....	8vo,	1 50
Kent, W. Strength of Materials. (Science Series No. 41.).....	16mo,	0 50
Kershaw, J. B. C. Fuel, Water and Gas Analysis.....	8vo,	*2 50
— Electrometallurgy. (Westminster Series.).....	8vo,	*2 00
— The Electric Furnace in Iron and Steel Production..	12mo,	*1 50
— Electro-Thermal Methods of Iron and Steel Production, 8vo,		*3 00
Kindelan, J. Trackman's Helper.....	12mo,	

24 D. VAN NOSTRAND COMPANY'S SHORT-TITLE CATALOG

Kinzbrunner, C. Alternate Current Windings.....	8vo,	*1 50
— Continuous Current Armatures.....	8vo,	*1 50
— Testing of Alternating Current Machines.....	8vo,	*2 00
Kirkaldy, A. W., and Evans, A. D. History and Economics of Transport.....	8vo,	*3 00
Kirkaldy, W. G. David Kirkaldy's System of Mechanical Testing.....	4to,	10 00
Kirkbride, J. Engraving for Illustration.....	8vo,	*1 50
Kirkham, J. E. Structural Engineering.....	8vo,	*5 00
Kirkwood, J. P. Filtration of River Waters.....	4to,	7 50
Kirschke, A. Gas and Oil Engines..	12mo.	*1 25
Klein, J. F. Design of a High speed Steam-engine..	8vo,	*5 00
— Physical Significance of Entropy.	8vo,	*1 50
Klingenberg, G. Large Electric Power Stations.....	4to,	*5 00
Knight, R.-Adm. A. M. Modern Seamanship.....	8vo,	*7 50
	Half Mor.	*9 00
Knott, C. G., and Mackay, J. S. Practical Mathematics..	8vo,	2 00
Knox, G. D. Spirit of the Soil.....	12mo,	*1 25
Knox, J. Physico-chemical Calculations	12mo,	*1 00
— Fixation of Atmospheric Nitrogen. (Chemical Mono- graphs.)	12mo,	0 75
Koester, F. Steam-Electric Power Plants.....	4to,	*5 00
— Hydroelectric Developments and Engineering.....	4to,	*5 00
Koller, T. The Utilization of Waste Products.....	8vo,	*3 00
— Cosmetics.....	8vo,	*2 50
Koppe, S. W. Glycerine.....	12mo,	*2 50
Kozmin, P. A. Flour Milling. Trans. by M. Falkner..	8vo,	
	(In Press.)	
Kremann, R. Application of Physico Chemical Theory to Technical Processes and Manufacturing Methods. Trans. by H. E. Potts.....	8vo,	*2 50
Kretchmar, K. Yarn and Warp Sizing.....	8vo,	*4 00
Lallier, E. V. Elementary Manual of the Steam Engine.	12mo,	*2 00
Lambert, T. Lead and its Compounds.....	8vo,	*3 50
— Bone Products and Manures.....	8vo,	*3 00

D. VAN NOSTRAND COMPANY'S SHORT-TITLE CATALOG 25

Lamborn, L. L. Cottonseed Products.....	8vo,	*3 00
— Modern Soaps, Candles, and Glycerin.....	8vo,	*7 50
Lamprecht, R. Recovery Work After Pit Fires. Trans. by C. Salter	8vo,	*4 00
Lancaster, M. Electric Cooking, Heating and Cleaning..	8vo,	*1 50
Lanchester, F. W. Aerial Flight. Two Volumes. 8vo.		
Vol. I. Aerodynamics		*6 00
Vol. II. Aerodnetics		*6 00
— The Flying Machine.....	(In Press.)	
Lange, K. R. By-Products of Coal-Gas Manufacture..	12mo,	2 00
Larner, E. T. Principles of Alternating Currents.....	12mo,	*1 25
La Rue, B. F. Swing Bridges. (Science Series No. 107.)	16mo,	0 50
Lassar-Cohn, Dr. Modern Scientific Chemistry. Trans. by M. M. Pattison Muir.....	12mo,	*2 00
Latimer, L. H., Field, C. J., and Howell, J. W. Incandescent Electric Lighting. (Science Series No. 57.)....	16mo,	0 50
Latta, M. N. Handbook of American Gas-Engineering Practice.		
	8vo,	*4 50
— American Producer Gas Practice	4to,	*6 00
Laws, B. C. Stability and Equilibrium of Floating Bodies.	8vo,	*3 50
Lawson, W. R. British Railways, a Financial and Commer- cial Survey	8vo,	2 00
Leask, A. R. Breakdowns at Sea.....	12mo,	2 00
— Refrigerating Machinery	12mo,	2 00
Lecky, S. T. S. "Wrinkles" in Practical Navigation....	8vo,	*10 00
Le Doux, M. ice-Making Machines. (Science Series No. 46.)		
	16mo,	0 50
Leeds, C. C. Mechanical Drawing for Trade Schools.	oblong 4to,	*2 00
— Mechanical Drawing for High and Vocational Schools,		
	4to,	*1 25
Lefèvre, L. Architectural Pottery. Trans. by H. K. Bird and W. M. Binns.....	4to,	*7 50
Lehner, S. Ink Manufacture. Trans. by A. Morris and H. Robson.....	8vo	*2 50
Lemstrom, S. Electricity in Agriculture and Horticulture..	8vo,	*1 50
Letts, E. A. Fundamental Problems in Chemistry.....	8vo,	*2 00

Le Van, W. B. Steam-Engine Indicator. (Science Series No. 78.).....	16mo,	0 50
Lewes, V. B. Liquid and Gaseous Fuels. (Westminster Series.)	8vo,	*2 00
— Carbonization of Coal.....	8vo,	*3 00
Lewis, L. P. Railway Signal Engineering.....	8vo,	*3 50
Licks, H. E. Recreations in Mathematics.....	12mo,	1 25
Lieber, B. F. Lieber's Five Letter Standard Telegraphic Code,	8vo,	*10 00
— Spanish Edition	8vo,	*10 00
— French Edition	8vo,	*10 00
— Terminal Index	8vo,	*2 50
— Lieber's Appendix	folio,	*15 00
— Handy Tables	4to,	*2 50
— Bankers and Stockbrokers' Code and Merchants and Shippers' Blank Tables	8vo,	*15 00
Lieber, B. F. 100,000,000 Combination Code.....	8vo,	*10 00
— Engineering Code.....	8vo,	*12 50
Livermore, V. P., and Williams, J. How to Become a Competent Motorman	12mo,	*1 00
Livingstone, R. Design and Construction of Commutators.....	8vo,	*2 25
— Mechanical Design and Construction of Generators.....	8vo,	*3 50
Lloyd, S. L. Fertilizer Materials.....	(In Press.)	
Lobben, P. Machinists' and Draftsmen's Handbook	8vo,	2 50
Lockwood, T. D. Electricity, Magnetism, and Electro-telegraphy.....	8vo,	2 50
— Electrical Measurement and the Galvanometer.....	12mo,	0 75
Lodge, O. J. Elementary Mechanics.....	12mo,	1 50
— Signalling Across Space without Wires.....	8vo,	*2 00
Loewenstein, L. C., and Crissey, C. P. Centrifugal Pumps..		*4 50
Lomax, J. W. Cotton Spinning.....	12mo,	1 50
Lord, R. T. Decorative and Fancy Fabrics.....	8vo,	*3 50
Loring, A. E. A Handbook of the Electromagnetic Telegraph,	16mo,	0 50
— Handbook. (Science Series No. 39).....	16mo,	0 50
Lovell, D. H. Practical Switchwork. Revised by Strong and Whitney	(In Press.)	

Low, D. A. Applied Mechanics (Elementary).....	16mo,	o 80
Lubschez, B. J. Perspective.....	12mo,	*1 50
Lucke, C. E. Gas Engine Design.....	8vo,	*3 00
— Power Plants: their Design, Efficiency, and Power Costs. 2 vols.....	(In Preparation.)	
Luckiesh, M. Color and Its Application.....	8vo,	*3 00
— Light and Shade and Their Applications.....	8vo,	*2 50
The two when purchased together.....		*5 00
Lunge, G. Coal-tar Ammonia. Three Parts.....	8vo,	*18 00
— Manufacture of Sulphuric Acid and Alkali. Four Volumes. 8vo,		
Vol. I. Sulphuric Acid. In three parts.....		*18 00
Vol. II. Salt Cake, Hydrochloric Acid and Leblanc Soda. In two parts.....		*15 00
Vol. III. Ammonia Soda.....		*10 00
Vol. IV. Electrolytic Methods.....	(In Press.)	
— Technical Chemists' Handbook.....	12mo, leather,	*3 50
— Technical Methods of Chemical Analysis. Trans. by C. A. Keane. In collaboration with the corps of specialists.		
Vol. I. In two parts.....	8vo,	*15 00
Vol. II. In two parts.....	8vo,	*18 00
Vol. III. In two parts.....	8vo,	*18 00
The set (3 vols.) complete.....		*48 00
— Technical Gas Analysis.....	8vo,	*4 00
Luquer, L. M. Minerals in Rock Sections.....	8vo,	*1 50
Macaulay, J., and Hall, C. Modern Railway Working. Eight vols.	4to,	20 00
Each volume separately.....		3 00
Macewen, H. A. Food Inspection.....	8vo,	*2 50
Mackenzie, N. F. Notes on Irrigation Works.....	8vo,	*2 50
Mackie, J. How to Make a Woolen Mill Pay.....	8vo,	*2 00
Maguire, Wm. R. Domestic Sanitary Drainage and Plumbing 8vo,		4 00
Malcolm, C. W. Textbook on Graphic Statics.....	8vo,	*3 00

Malcolm, H. W. Submarine Telegraph Cable.....	(In Press.)	
Mallet, A. Compound Engines. Trans. by R. R. Buel. (Science Series No. 10.).....	16mo,	
Mansfield, A. N. Electro-magnets. (Science Series No. 64)	16mo,	0 50
Marks, E. C. R. Construction of Cranes and Lifting Machinery	12mo,	*1 50
— Construction and Working of Pumps.....	12mo,	*1 50
— Manufacture of Iron and Steel Tubes.....	12mo,	*2 00
— Mechanical Engineering Materials.....	12mo,	*1 00
Marks, G. C. Hydraulic Power Engineering.....	8vo,	3 50
— Inventions, Patents and Designs.....	12mo,	*1 00
Marlow, T. G. Drying Machinery and Practice.....	8vo,	*5 00
Marsh, C. F. Concise Treatise on Reinforced Concrete....	8vo,	*2 50
Marsh, C. F. Reinforced Concrete Compression Member Diagram Mounted on Cloth Boards.....		*1 50
Marsh, C. F., and Dunn, W. Manual of Reinforced Concrete and Concrete Block Construction.....	16mo, mor.,	*2 50
Marshall, W. J., and Sankey, H. R. Gas Engines. (Westminster Series.).....	8vo,	*2 00
Martin, G. Triumphs and Wonders of Modern Chemistry.	1	
	8vo,	*2 00
— Modern Chemistry and Its Wonders.....	8vo,	*2 00
Martin, N. Properties and Design of Reinforced Concrete,	12mo,	*2 50
Martin, W. D. Hints to Engineers.....	12mo,	*1 00
Massie, W. W., and Underhill, C. R. Wireless Telegraphy and Telephony.....	12mo,	*1 00
Mathot, R. E. Internal Combustion Engines.....	8vo,	*4 00
Maurice, W. Electric Blasting Apparatus and Explosives ..	8vo,	*3 50
— Shot Firer's Guide.....	8vo,	*1 50
Maxwell, J. C. Matter and Motion. (Science Series No. 36.)	16mo,	0 50
Maxwell, W. H., and Brown, J. T. Encyclopedia of Municipal and Sanitary Engineering.....	4to,	*10 00
Mayer, A. M. Lecture Notes on Physics.....	8vo,	2 00
Mayer, C., and Slippy, J. C. Telephone Line Construction.	8vo,	*3 00

D. VAN NOSTRAND COMPANY'S SHORT-TITLE CATALOG 29

McCullough, E. Practical Surveying.....	12mo,	*2 00
— Engineering Work in Cities and Towns.....	8vo,	*3 00
— Reinforced Concrete	12mo,	*1 50
McCullough, R. S. Mechanical Theory of Heat.....	8vo,	3 50
McGibbon, W. C. Indicator Diagrams for Marine Engineers,	8vo,	*3 00
— Marine Engineers' Drawing Book.....	oblong	*2 00
— Marine Engineers' Pocketbook.....	12mo, leather,	*4 00
McIntosh, J. G. Technology of Sugar.....	8vo,	*5 00
— Industrial Alcohol.....	8vo,	*3 00
— Manufacture of Varnishes and Kindred Industries.		
Three Volumes. 8vo.		
Vol. I. Oil Crushing, Refining and Boiling		*3 50
Vol. II. Varnish Materials and Oil Varnish Making.....		*4 00
Vol. III. Spirit Varnishes and Materials.....		*4 50
McKnight, J. D., and Brown, A. W. Marine Multitubular		
Boilers.....		*1 50
McMaster, J. B. Bridge and Tunnel Centres. (Science Series		
No. 20.).....	16mo,	0 50
McMechen, F. L. Tests for Ores, Minerals and Metals... ..	12mo,	*1 00
McPherson, J. A. Water-works Distribution	8vo,	2 50
Meade, R. K. Design and Equipment of Small Chemical		
Laboratories	8vo,	
Melick, C. W. Dairy Laboratory Guide.....	12mo,	*1 25
Mensch, L. J. Reinforced Concrete Pocket Book. 16mo, leather		*4 00
Merck, E. Chemical Reagents: Their Purity and Tests.		
Trans. by H. E. Schenck.....	8vo,	1 00
Merivale, J. H. Notes and Formulae for Mining Students,	12mo,	1 50
Merritt, Wm. H. Field Testing for Gold and Silver. 16mo, leather,		1 50
Mierzinski, S. Waterproofing of Fabrics. Trans. by A. Morris		
and H. Robson.....	8vo,	*2 50
Miessner, B. F. Radiodynamics.....	12mo,	*2 00
Miller, G. A. Determinants. (Science Series No. 105.)..	16mo,	
Miller, W. J. Historical Geology.....	12mo,	*2 00
Mills, C. N. Elementary Mechanics for Engineers.....	12mo,	*1 00
Milroy, M. E. W. Home Lace-making.....	12mo,	*1 00

Mitchell, C. A. Mineral and Aerated Waters.....	8vo,	*3 00
— and Prideaux, R. M. Fibres Used in Textile and Allied Industries.....	8vo,	*3 00
Mitchell, C. F. and G. A. Building Construction and Drawing.	12mo	
	Elementary Course,	*1 50
	Advanced Course,	*2 50
Monckton, C. C. F. Radiotelegraphy. (Westminster Series.)	8vo,	*2 00
Monteverde, R. D. Vest Pocket Glossary of English-Spanish, Spanish-English Technical Terms.	64mo, leather,	*1 00
Montgomery, J. H. Electric Wiring Specifications....	16mo,	*1 00
Moore, E. C. S. New Tables for the Complete Solution of Ganguillet and Kutter's Formula.	8vo,	*5 00
Morecroft, J. H., and Hehre, F. W. Short Course in Electrical Testing.	8vo,	*1 50
Morgan, A. P. Wireless Telegraph Apparatus for Amateurs,	12mo,	*1 50
Moses, A. J. The Characters of Crystals.	8vo,	*2 00
— and Parsons, C. L. Elements of Mineralogy.....	8vo,	
Moss, S. A. Elements of Gas Engine Design. (Science Series No. 121).....	16mo,	0 50
— The Lay-out of Corliss Valve Gears. (Science Series No. 119.)	16mo,	0 50
Mulford, A. C. Boundaries and Landmarks.....	12mo,	*1 00
Mullin, J. P. Modern Moulding and Pattern-making....	12mo,	2 50
Munby, A. E. Chemistry and Physics of Building Materials. (Westminster Series.).....	8vo,	*2 00
Murphy, J. G. Practical Mining.....	16mo,	1 00
Murphy, W. S. Textile Industries, 8 vols.....		*20 00
— (Sold separately.)	each,	*3 00
Murray, J. A. Soils and Manures. (Westminster Series.)	8vo,	*2 00
Nasmith, J. The Student's Cotton Spinning.....	8vo,	3 00
— Recent Cotton Mill Construction.....	12mo,	2 50
Neave, G. B., and Heilbron, I. M. Identification of Organic Compounds.....	12mo,	*1 25

Neilson, R. M. Aeroplane Patents.....	8vo,	*2 00
Nerz, F. Searchlights. Trans. by C. Rodgers.....	8vo,	*3 00
Neuberger, H., and Noalhat, H. Technology of Petroleum. Trans. by J. G. McIntosh.....	8vo,	*10 00
Newall, J. W. Drawing, Sizing and Cutting Bevel-gears..	8vo,	1 50
Newbigin, T. Handbook for Gas Engineers and Managers, 8vo,		*6 50
Newell, F. H., and Drayer, C. E. Engineering as a Career. 12mo, cloth,		*1 00
	paper,	0 75
Nicol, G. Ship Construction and Calculations.....	8vo,	*4 50
Nipher, F. E. Theory of Magnetic Measurements.....	12mo,	1 00
Nisbet, H. Grammar of Textile Design.....	8vo,	*3 00
Nolan, H. The Telescope. (Science Series No. 51.)....	16mo,	0 50
North, H. B. Laboratory Experiments in General Chemistry 12mo,		*1 00
Nugent, E. Treatise on Optics	12mo,	1 50
O'Connor, H. The Gas Engineer's Pocketbook. . .	12mo, leather,	3 50
Ohm, G. S., and Lockwood, T. D. Galvanic Circuit. Trans. by William Francis. (Science Series No. 102.) . . .	16mo,	0 50
Olsen, J. C. Textbook of Quantitative Chemical Analysis..	8vo,	*3 50
Olsson, A. Motor Control, in Turret Turning and Gun Elevating. (U. S. Navy Electrical Series, No. 1.) . . .	12mo, paper,	*0 50
Ormsby, M. T. M. Surveying.....	12mo,	1 50
Oudin, M. A. Standard Polyphase Apparatus and Systems ..	8vo,	*3 00
Owen, D. Recent Physical Research.....	8vo,	*1 50
Pakes, W. C. C., and Nankivell, A. T. The Science of Hygiene. 8vo,		*1 75
Palaz, A. Industrial Photometry. Trans. by G. W. Patterson, Jr.....	8vo,	*4 00
Pamely, C. Colliery Manager's Handbook.....	8vo,	*10 00
Parker, P. A. M. The Control of Water.....	8vo,	*5 00
Parr, G. D. A. Electrical Engineering Measuring Instruments. 8vo,		*3 50
Parry, E. J. Chemistry of Essential Oils and Artificial Per- fumes.....	8vo,	*5 00

Parry, E. J. Foods and Drugs. Two Volumes.....	8vo.	
Vol. I. Chemical and Microscopical Analysis of Food and Drugs.....		*7.50
Vol. II. Sale of Food and Drugs Acts.....		*3.00
— and Coste, J. H. Chemistry of Pigments.....	8vo,	*4.50
Parry, L. Notes on Alloys.....	8vo,	*3.00
— Metalliferous Wastes.....	8vo,	*2.00
— Analysis of Ashes and Alloys.....	8vo,	*2.00
Parry, L. A. Risk and Dangers of Various Occupations....	8vo,	*3.00
Parshall, H. F., and Hobart, H. M. Armature Windings...	4to,	*7.50
— Electric Railway Engineering.....	4to,	*10.00
Parsons, J. L. Land Drainage.....	8vo,	*1.50
Parsons, S. J. Malleable Cast Iron.....	8vo,	*2.50
Partington, J. R. Higher Mathematics for Chemical Students		
	12mo,	*2.00
— Textbook of Thermodynamics.....	8vo,	*4.00
Passmore, A. C. Technical Terms Used in Architecture...	8vo,	*3.50
Patchell, W. H. Electric Power in Mines.....	8vo,	*4.00
Paterson, G. W. L. Wiring Calculations.....	12mo,	*2.00
— Electric Mine Signalling Installations.....	12mo,	*1.50
Patterson, D. The Color Printing of Carpet Yarns.....	8vo,	*3.50
— Color Matching on Textiles.....	8vo,	*3.00
— Textile Color Mixing.....	8vo,	*3.00
Paulding, C. P. Condensation of Steam in Covered and Bare Pipes.....	8vo,	*2.00
— Transmission of Heat Through Cold-storage Insulation		
	12mo,	*1.00
Payne, D. W. Founders' Manual.....	(In Press.)	
Peckham, S. F. Solid Bitumens.....	8vo,	*5.00
Peddie, R. A. Engineering and Metallurgical Books....	12mo,	*1.50
Peirce, B. System of Analytic Mechanics.....	4to,	10.00
— Linear Associative Algebra.....	4to,	3.00
Pendred, V. The Railway Locomotive. (Westminster Series.)		
	8vo,	*2.00
Perkin, F. M. Practical Method of Inorganic Chemistry...	1 mo,	*1.00
— and Jaggars, E. M. Elementary Chemistry.....	12mo,	*1.00
Perrine, F. A. C. Conductors for Electrical Distribution...	8vo,	*3.50

Petit, G. White Lead and Zinc White Paints.....	8vo,	*1	50
Petit, R. How to Build an Aeroplane. Trans. by T. O'B. Hubbard, and J. H. Ledebøer.....	8vo,	*1	50
Pettit, Lieut. J. S. Graphic Processes. (Science Series No. 76.)	16mo,	0	50
Philbrick, P. H. Beams and Girders. (Science Series No. 88.)	16mo,		
Phillips, J. Gold Assaying.....	8vo,	*2	50
— Dangerous Goods.....	8vo,	3	50
Phin, J. Seven Follies of Science.....	12mo,	*1	25
Pickworth, C. N. The Indicator Handbook. Two Volumes	12mo, each,	1	50
— Logarithms for Beginners	12mo, boards,	0	50
— The Slide Rule.....	12mo,	1	00
Plattner's Manual of Blowpipe Analysis. Eighth Edition, revised. Trans. by H. B. Cornwall.....	8vo,	*4	00
Plympton, G. W. The Aneroid Barometer. (Science Series.)	16mo,	0	50
— How to become an Engineer. (Science Series No. 100.)	16mo,	0	50
— Van Nostrand's Table Book. (Science Series No. 104.)	16mo,	0	50
Pochet, M. L. Steam Injectors. Translated from the French. (Science Series No. 29.).....	16mo,	0	50
Pocket Logarithms to Four Places. (Science Series.).....	16mo,	0	50
	leather,	1	00
Polleyn, F. Dressings and Finishings for Textile Fabrics.	8vo,	*3	00
Pope, F. G. Organic Chemistry.....	12mo,	*2	25
Pope, F. L. Modern Practice of the Electric Telegraph....	8vo,	1	50
Popplewell, W. C. Prevention of Smoke.....	8vo,	*3	50
— Strength of Materials.....	8vo,	*1	75
Porritt, B. D. The Chemistry of Rubber. (Chemical Monographs, No. 3.).....	12mo,	*0	75
Porter, J. R. Helicopter Flying Machine.....	12mo,	*1	25
Potts, H. E. Chemistry of the Rubber Industry. (Outlines of Industrial Chemistry.).....	8vo,	*2	00
Practical Compounding of Oils, Tallow and Grease.....	8vo,	*3	50

Pratt, K. Boiler Draught.....	12mo,	*1 25
— High Speed Steam Engines.....	8vo,	*2 00
Pray, T., Jr. Twenty Years with the Indicator.....	8vo,	2 50
— Steam Tables and Engine Constant.....	8vo,	2 00
Prelini, C. Earth and Rock Excavation.....	8vo,	*3 00
— Graphical Determination of Earth Slopes.....	8vo,	*2 00
— Tunneling. New Edition.....	8vo,	*3 00
— Dredging. A Practical Treatise.....	8vo,	*3 00
Prescott, A. B. Organic Analysis.....	8vo,	5 00
— and Johnson, O. C. Qualitative Chemical Analysis.....	8vo,	*3 50
— and Sullivan, E. C. First Book in Qualitative Chemistry.....	12mo,	*1 50
Prideaux, E. B. R. Problems in Physical Chemistry.....	8vo,	*2 00
Primrose, G. S. C. Zinc. (Metallurgy Series.).....	(In Press.)	
Prince, G. T. Flow of Water.....	12mo,	*2 00
Pullen, W. W. F. Application of Graphic Methods to the Design of Structures.....	12mo,	*2 50
— Injectors: Theory, Construction and Working.....	12mo,	*1 50
— Indicator Diagrams.....	8vo,	*2 50
— Engine Testing.....	8vo,	*4 50
Pulsifer, W. H. Notes for a History of Lead.....	8vo,	4 00
Putsch, A. Gas and Coal-dust Firing.....	8vo,	*3 00
Pynchon, T. R. Introduction to Chemical Physics.....	8vo,	3 00
Rafter, G. W. Mechanics of Ventilation. (Science Series No. 33.).....	16mo,	0 50
— Potable Water. (Science Series No. 103.).....	16mo,	0 50
— Treatment of Septic Sewage. (Science Series No. 118.)	16mo,	0 50
— and Baker, M. N. Sewage Disposal in the United States	4to,	*6 00
Raikes, H. P. Sewage Disposal Works.....	8vo,	*4 00
Randau, P. Enamels and Enamelling.....	8vo,	*4 00
Rankine, W. J. M. Applied Mechanics.....	8vo,	5 00
— Civil Engineering.....	8vo,	6 50
— Machinery and Millwork.....	8vo,	5 00
— The Steam-engine and Other Prime Movers.....	8vo,	5 00
— and Bamber, E. F. A Mechanical Textbook.....	8vo,	3 50

Ransome, W. R. Freshman Mathematics.....	12mo,	*1 35
Raphael, F. C. Localization of Faults in Electric Light and Power Mains.....	8vo,	*3 50
Rasch, E. Electric Arc Phenomena. Trans. by K. Tornberg.	8vo,	*2 00
Rathbone, R. L. B. Simple Jewellery.....	8vo,	*2 00
Rateau, A. Flow of Steam through Nozzles and Orifices. Trans. by H. B. Brydon.....	8vo,	*1 50
Rausenberger, F. The Theory of the Recoil of Guns....	8vo,	*4 50
Rautenstrauch, W. Notes on the Elements of Machine Design, 8vo, boards,		*1 50
Rautenstrauch, W., and Williams, J. T. Machine Drafting and Empirical Design.		
Part I. Machine Drafting.....	8vo,	*1 25
Part II. Empirical Design.....	(In Preparation.)	
Raymond, E. B. Alternating Current Engineering....	12mo,	*2 50
Rayner, H. Silk Throwing and Waste Silk Spinning... 8vo,		*2 50
Recipes for the Color, Paint, Varnish, Oil, Soap and Drysaltery Trades	8vo,	*3 50
Recipes for Flint Glass Making.....	12mo,	*4 50
Redfern, J. B., and Savin, J. Bells, Telephones. (Installat- ion Manuals Series.).....	16mo,	*0 50
Redgrove, H. S. Experimental Mensuration.....	12mo,	*1 25
Redwood, B. Petroleum. (Science Series No. 92.)... 16mo,		0 50
Reed, S. Turbines Applied to Marine Propulsion.....		*5 00
Reed's Engineers' Handbook.....	8vo,	*5 00
— Key to the Nineteenth Edition of Reed's Engineers' Handbook	8vo,	*3 00
— Useful Hints to Sea-going Engineers.....	12mo,	1 50
Reid, E. E. Introduction to Research in Organic Chemistry. (In Press.)		
Reid, H. A. Concrete and Reinforced Concrete Construction, 8vo,		*5 00
Reinhardt, C. W. Lettering for Draftsmen, Engineers, and Students.....	oblong 4to, boards,	1 00
— The Technic of Mechanical Drafting. oblong 4to, boards,		*1 00

Reiser, F. Hardening and Tempering of Steel. Trans. by A. Morris and H. Robson.....	12mo,	*2 50
Reiser, N. Faults in the Manufacture of Woolen Goods. Trans. by A. Morris and H. Robson	8vo,	*2 50
— Spinning and Weaving Calculations.....	8vo,	*5 00
Renwick, W. G. Marble and Marble Working.....	8vo,	5 00
Réuleaux, F. The Constructor. Trans. by H. H. Suplee	4to,	*4 00
Reuterdahl, A. Theory and Design of Reinforced Concrete Arches	8vo,	*2 00
Reynolds, O., and Idell, F. E. Triple Expansion Engines. (Science Series No. 99.).....	16mo,	0 50
Rhead, G. F. Simple Structural Woodwork.....	12mo,	*1 00
Rhodes, H. J. Art of Lithography.....	8vo,	3 50
Rice, J. M., and Johnson, W. W. A New Method of Obtaining the Differential of Functions.....	12mo,	0 50
Richards, W. A. Forging of Iron and Steel.....	12mo,	1 50
Richards, W. A., and North, H. B. Manual of Cement Testing,	12mo,	*1 50
Richardson, J. The Modern Steam Engine.....	8vo,	*3 50
Richardson, S. S. Magnetism and Electricity.....	12mo,	*2 00
Rideal, S. Glue and Glue Testing.....	8vo,	*4 00
Rimmer, E. J. Boiler Explosions, Collapses and Mishaps.....	8vo,	*1 75
Rings, F. Concrete in Theory and Practice.....	12mo,	*2 50
— Reinforced Concrete Bridges.....	4to,	*5 00
Ripper, W. Course of Instruction in Machine Drawing... folio,		*6 00
Roberts, F. C. Figure of the Earth. (Science Series No. 79.)	16mo,	0 50
Roberts, J., Jr. Laboratory Work in Electrical Engineering	8vo,	*2 00
Robertson, L. S. Water-tube Boilers.....	8vo,	2 00
Robinson, J. B. Architectural Composition.....	8vo,	*2 50
Robinson, S. W. Practical Treatise on the Teeth of Wheels. (Science Series No. 24.).....	16mo,	0 50
— Railroad Economics. (Science Series No. 59.)....	16mo,	0 50
— Wrought Iron Bridge Members. (Science Series No. 60.).....	16mo,	0 50

Robson, J. H. Machine Drawing and Sketching.....	8vo,	*1 50
Roebing, J. A. Long and Short Span Railway Bridges..	folio,	25 00
Rogers, A. A Laboratory Guide of Industrial Chemistry..	12mo,	*1 50
— Elements of Industrial Chemistry.....	12mo,	*2 50
— Industrial Chemistry	8vo,	*5 00
Rogers, F. Magnetism of Iron Vessels. (Science Series No. 30.)		
	16mo,	0 50
Rohland, P. Colloidal and its Crystalloidal State of Matter.		
Trans. by W. J. Britland and H. E. Potts.....	12mo,	*1 25
Rollins, W. Notes on X-Light.....	8vo,	*5 00
Rollinson, C. Alphabets.....	obl. long 12mo,	*1 00
Rose, J. The Pattern-makers' Assistant.....	8vo,	2 50
— Key to Engines and Engine-running.....	12mo,	2 50
Rose, T. K. The Precious Metals. (Westminster Series)..	8vo,	*2 00
Rosenhain, W. Glass Manufacture. (Westminster Series)..	8vo,	*2 00
— Physical Metallurgy, An Introduction to. (Metallurgy Series.)	8vo,	*3 50
Roth, W. A. Physical Chemistry.....	8vo,	*2 00
Rothery, G. C., and Edmonds, H. O. The Modern Laundry.		
2 vols.....	4to, half leather,	*12 00
Rowan, F. J. Practical Physics of the Modern Steam-boiler.	8vo,	*3 00
— and Idell, F. E. Boiler Incrustation and Corrosion.		
(Science Series No. 27.).....	16mo,	0 50
Roxburgh, W. General Foundry Practice. (Westminster Series.)	8vo,	*2 00
Ruhmer, E. Wireless Telephony. Trans. by J. Erskine-Murray.....	8vo,	*3 50
Russell, A. Theory of Electric Cables and Networks.....	8vo,	*3 00
Rutley, F. Elements of Mineralogy.....	12mo,	*1 25
Sanford, P. G. Nitro-explosives.....	8vo,	*4 00
Saunders, C. H. Handbook of Practical Mechanics.....	16mo,	1 00
	leather,	1 25
Sayers, H. M. Brakes for Tram Cars.....	8vo,	*1 25
Scheele, C. W. Chemical Essays.....	8vo,	*2 00
Scheithauer, W. Shale Oils and Tars.....	8vo,	*3 50
Scherer, R. Casein. Trans. by C. Salter.....	8vo,	*3 00

Schidrowitz, P. Rubber, Its Production and Industrial Uses,	8vo,	*5 00
Schindler, K. Iron and Steel Construction Works	12mo,	*1 25
Schmall, C. N. First Course in Analytic Geometry, Plane and Solid	12mo, half leather,	*1 75
Schmall, C. N., and Schack, S. M. Elements of Plane Geometry	12mo,	*1 25
Schmeer, L. Flow of Water	8vo,	*3 00
Schumann, F. A Manual of Heating and Ventilation.	12mo, leather,	1 50
Schwartz, E. H. L. Causal Geology	8vo,	*2 50
Schweizer, V. Distillation of Resins	8vo,	*3 50
Scott, W. W. Qualitative Analysis. A Laboratory Manual,	8vo,	*1 50
— Technical Methods of Analysis	8vo (<i>In Press.</i>)	
Scribner, J. M. Engineers' and Mechanics' Companion.	16mo, leather,	1 50
Scudder, H. Electrical Conductivity and Ionization Constants of Organic Compounds	8vo,	*3 00
Searle, A. B. Modern Brickmaking	8vo,	*5 00
— Cement, Concrete and Bricks	8vo,	*3 00
Searle, G. M. "Sumners' Method." Condensed and Improved. (Science Series No. 124.)	16mo,	0 50
Seaton, A. E. Manual of Marine Engineering	8vo,	8 00
Seaton, A. E., and Rounthwaite, H. M. Pocket-book of Marine Engineering	16mo, leather,	3 50
Seeligmann, T., Torrilhon, G. L., and Falconnet, H. India Rubber and Gutta Percha. Trans. by J. G. McIntosh	8vo,	*5 00
Seidell, A. Solubilities of Inorganic and Organic Substances	8vo,	*3 00
Seligman, R. Aluminum. (<i>Metallurgy Series</i>)	(<i>In Press.</i>)	
Sellew, W. H. Steel Rails	4to,	*12 50
— Railway Maintenance Engineering	12mo,	*2 50
Senter, G. Outlines of Physical Chemistry	12mo,	*1 75
— Textbook of Inorganic Chemistry	12mo,	*1 75
Sever, G. F. Electric Engineering Experiments	8vo, boards,	*1 00
— and Townsend, F. Laboratory and Factory Tests in Elec- trical Engineering	8vo,	*2 50

Sewall, C. H. Wireless Telegraphy.....	8vo,	*2 00
— Lessons in Telegraphy.....	12mo,	*1 00
Sewell, T. The Construction of Dynamos.....	8vo,	*3 00
Sexton, A. H. Fuel and Refractory Materials.....	12mo,	*2 50
— Chemistry of the Materials of Engineering.....	12mo,	*2 50
— Alloys (Non-Ferrous).....	8vo,	*3 00
— and Primrose, J. S. G. The Metallurgy of Iron and Steel,	8vo,	*6 50
Seymour, A. Modern Printing Inks.....	8vo,	*2 00
Shaw, Henry S. H. Mechanical Integrators. (Science Series No. 83.).....	16mo,	0 50
Shaw, S. History of the Staffordshire Potteries.....	8vo,	2 00
— Chemistry of Compounds Used in Porcelain Manufacture.....	8vo,	*5 00
Shaw, W. N. Forecasting Weather.....	8vo,	*3 50
Sheldon, S., and Hausmann, E. Direct Current Machines.....	12mo,	*2 50
— Alternating-current Machines.....	12mo,	*2 50
— Electric Traction and Transmission Engineering.....	12mo,	*2 50
Shields, J. E. Note on Engineering Construction.....	12mo,	1 50
Shreve, S. H. Strength of Bridges and Roofs.....	8vo,	3 50
Shunk, W. F. The Field Engineer.....	12mo, mor.,	2 50
Simmons, W. H., and Appleton, H. A. Handbook of Soap Manufacture.....	8vo,	*3 00
Simmons, W. H., and Mitchell, C. A. Edible Fats and Oils,	8vo,	*3 00
Simpson, G. The Naval Constructor.....	12mo, mor.,	*5 00
Simpson, W. Foundations.....	8vo (In Press.)	
Sinclair, A. Development of the Locomotive Engine.	8vo, half leather,	5 00
Sindall, R. W. Manufacture of Paper. (Westminster Series.)	8vo,	*2 00
— and Bacon, W. N. The Testing of Wood Pulp.....	8vo,	*2 50
Sloane, T. O'C. Elementary Electrical Calculations.....	12mo,	*2 00
Smallwood, J. C. Mechanical Laboratory Methods. (Van Nostrand's Textbooks.).....	12mo, leather,	*2 50
Smith, C. A. M. Handbook of Testing; MATERIALS.....	8vo,	*2 50
— and Warren, A. G. New Steam Tables.....	8vo,	*1 25
Smith, C. F. Practical Alternating Currents and Testing.....	8vo,	*2 50
— Practical Testing of Dynamos and Motors.....	8vo,	*2 00

Smith, F. A. Railway Curves.....	12mo,	*1 00
— Standard Turnouts on American Railroads.....	12mo,	*1 00
— Maintenance of Way Standards.....	12mo,	*1 50
Smith, F. E. Handbook of General Instruction for Mechanics.		
	12mo,	1 50
Smith, H. G. Minerals and the Microscope.....	12mo,	*1 25
Smith, J. C. Manufacture of Paint.....	8vo,	*3 50
Smith, R. H. Principles of Machine Work.....	12mo,	
— Advanced Machine Work.....	12mo,	*3 00
Smith, W. Chemistry of Hat Manufacturing.....	12mo,	*3 00
Snell, A. T. Electric Motive Power.....	8vo,	*4 00
Snow, W. G. Pocketbook of Steam Heating and Ventilation,		
		(In Press.)
Snow, W. G., and Nolan, T. Ventilation of Buildings. (Science		
Series No. 5.).....	16mo,	0 50
Soddy, F. Radioactivity.....	8vo,	*3 00
Solomon, M. Electric Lamps. (Westminster Series.)....	8vo,	*2 00
Somerscales, A. N. Mechanics for Marine Engineers.....	12mo,	*1 50
— Mechanical and Marine Engineering Science.....	8vo,	*5 00
Sothorn, J. W. The Marine Steam Turbine.....	8vo,	*6 00
— Verbal Notes and Sketches for Marine Engineers... ..	8vo,	*5 00
Sothorn, J. W., and Sothorn, R. M. Elementary Mathematics		
for Marine Engineers.....	12mo,	*1 00
— Simple Problems in Marine Engineering Design....	12mo,	*1 00
Southcombe, J. E. Chemistry of the Oil Industries. (Out-		
lines of Industrial Chemistry).....	8vo,	*3 00
Soxhlet, D. H. Dyeing and Staining Marble. Trans. by A.		
Morris and H. Robson.....	8vo,	*2 50
Spang, H. W. A Practical Treatise on Lightning Protection.....	12mo,	1 00
Spangenburg, L. Fatigue of Metals. Translated by S. H.		
Shreve. (Science Series No. 23.).....	16mo,	0 50
Specht, G. J., Hardy, A. S., McMaster, J. B., and Walling. Topo-		
graphical Surveying. (Science Series No. 72.)....	16mo,	0 50
Spencer, A. S. Design of Steel-Framed Sheds.....	8vo,	*3 50
Speyers, C. L. Text-book of Physical Chemistry.....	8vo,	*2 25
Spiegel, L. Chemical Constitution and Physiological Action.		
(Trans. by C. Luedeking and A. C. Boylston.).....	12mo,	*1 25

Sprague, E. H. Hydraulics.....	12mo,	1 25
— Stability of Masonry.....	12mo,	1 25
Stahl, A. W. Transmission of Power. (Science Series No. 28.)		
	16mo,	
— and Woods, A. T. Elementary Mechanism.....	12mo,	*2 00
Staley, C., and Pierson, G. S. The Separate System of Sewerage.		
	8vo,	*3 00
Standage, H. C. Leatherworkers' Manual.....	8vo,	*3 50
— Sealing Waxes, Wafers, and Other Adhesives.....	8vo,	*2 00
— Agglutinants of All Kinds for All Purposes.....	12mo,	*3 50
Stanley, H. Practical Applied Physics.....	(In Press.)	
Stansbie, J. H. Iron and Steel. (Westminster Series.)...	8vo,	*2 00
Steadman, F. M. Unit Photography.....	12mo,	*2 00
Stecher, G. E. Cork. Its Origin and Industrial Uses.....	12mo,	1 00
Steinman, D. B. Suspension Bridges and Cantilevers. (Science Series No. 127.).....		0 50
— Melan's Steel Arches and Suspension Bridges.....	8vo,	*3 00
Stevens, H. P. Paper Mill Chemist.....	16mo,	*2 50
Stevens, J. S. Theory of Measurements.....	12mo,	*1 25
Stevenson, J. L. Blast-Furnace Calculations.....	12mo, leather,	*2 00
Stewart, G. Modern Steam Traps.....	12mo,	*1 25
Stiles, A. Tables for Field Engineers.....	12mo,	1 00
Stodola, A. Steam Turbines. Trans. by L. C. Loewenstein.....	8vo,	*5 00
Stone, H. The Timbers of Commerce.....	8vo,	3 50
Stopes, M. Ancient Plants.....	8vo,	*2 00
— The Study of Plant Life.....	8vo,	*2 00
Stumpf, Prof. Una-Flow Steam Engine.....	4to,	*3 50
Sudborough, J. J., and James, T. C. Practical Organic Chemistry.....	12mo,	*2 00
Suffling, E. R. Treatise on the Art of Glass Painting.....	8vo,	*3 50
Sullivan, T. V., and Underwood, N. Testing and Valuation of Building and Engineering Materials.....	(In Press.)	
Sur, F. J. S. Oil Prospecting and Extracting.....	8vo,	*1 00
Svenson, C. L. Handbook on Piping.....	(In Press.)	
Swan, K. Patents, Designs and Trade Marks. (Westminster Series.).....	8vo,	*2 00

Swinburne, J., Wordingham, C. H., and Martin, T. C. Electric Currents. (Science Series No. 109.).....	16mo,	0 50
Swoope, C. W. Lessons in Practical Electricity.....	12mo,	*2 00
Tailfer, L. Bleaching Linen and Cotton Yarn and Fabrics.	8vo,	*5 00
Tate, J. S. Surcharged and Different Forms of Retaining-walls. (Science Series No. 7.).....	16mo,	0 50
Taylor, F. N. Small Water Supplies.....	12mo,	*2 00
— Masonry in Civil Engineering.....	8vo,	*2 50
Taylor, T. U. Surveyor's Handbook.....	12mo, leather,	*2 00
— Backbone of Perspective.....	12mo,	*1 00
Taylor, W. P. Practical Cement Testing.....	8vo,	*3 00
Templeton, W. Practical Mechanic's Workshop Companion,	12mo, morocco,	2 00
Tenney, E. H. Test Methods for Steam Power Plants. (Van Nostrand's Textbooks.).....	12mo,	*2 50
Terry, H. L. India Rubber and its Manufacture. (Westminster Series.)	8vo,	*2 00
Thayer, H. R. Structural Design.....	8vo,	
Vol. I. Elements of Structural Design.....		*2 00
Vol. II. Design of Simple Structures.....		*4 00
Vol. III. Design of Advanced Structures.....	(In Preparation.)	
— Foundations and Masonry.....	(In Preparation.)	
Thiess, J. B., and Joy, G. A. Toll Telephone Practice.	8vo,	*3 50
Thom, C., and Jones, W. H. Telegraphic Connections.	oblong 12mo,	1 50
Thomas, C. W. Paper-makers' Handbook.....	(In Press.)	
Thompson, A. B. Oil Fields of Russia.....	4to,	*7 50
— Oil Field Development and Petroleum Mining....	8vo,	*7 50
Thompson, S. P. Dynamo Electric Machines. (Science Series No. 75.).....	16mo,	0 50
Thompson, W. P. Handbook of Patent Law of All Countries,	16mo,	1 50
Thomson, G. Modern Sanitary Engineering.....	12mo,	*3 00
Thomson, G. S. Milk and Cream Testing.....	12mo,	*1 75
— Modern Sanitary Engineering, House Drainage, etc.	8vo,	*3 00

Thornley, T. Cotton Combing Machines.....	8vo,	*3 00
— Cotton Waste	8vo,	*3 00
— Cotton Spinning	8vo,	
First Year		*1 50
Second Year		*3 00
Third Year		*2 50
Thurso, J. W. Modern Turbine Practice.....	8vo,	*4 00
Tidy, C. Meymott. Treatment of Sewage. (Science Series No. 94.)	16mo,	0 50
Tillmans, J. Water Purification and Sewage Disposal. Trans. by Hugh S. Taylor.....	8vo,	*2 00
Tinney, W. H. Gold-mining Machinery.....	8vo,	*3 00
Titherley, A. W. Laboratory Course of Organic Chemistry.....	8vo,	*2 00
Tizard, H. T. Indicators.....	(In Press.)	
Toch, M. Chemistry and Technology of Paints.....	8vo,	*4 00
— Materials for Permanent Painting.....	12mo,	*2 00
Tod, J., and McGibbon, W. C. Marine Engineers' Board of Trade Examinations	8vo,	*1 50
Todd, J., and Whall, W. B. Practical Seamanship.....	8vo,	*7 50
Tonge, J. Coal. (Westminster Series.).....	8vo,	*2 00
Townsend, F. Alternating Current Engineering.....	boards,	*0 75
Townsend, J. Ionization of Gases by Collision.....	8vo,	*1 25
Transactions of the American Institute of Chemical Engineers. Seven volumes now ready. Vols. I to VIII., 1908-1915, 8vo, each,		*6 00
Traverse Tables. (Science Series No. 115.).....	16mo,	0 50
	mor.,	1 00
Treiber, E. Foundry Machinery. Trans. by C. Salter.....	12mo,	1 25
Trinks, W., and Housum, C. Shaft Governors. (Science Series No. 122.).....	16mo,	0 50
Trowbridge, D. C. Handbook for Engineering Draughtsmen. (In Press.)		
Trowbridge, W. P. Turbine Wheels. (Science Series No. 44.) 16mo,		0 50
Tucker, J. H. A Manual of Sugar Analysis.....	8vo,	3 50
Tunner, P. A. Treatise on Roll-turning. Trans. by J. B. Pearse.....	8vo text and folio atlas,	10 00

Turnbull, Jr., J., and Robinson, S. W. A Treatise on the Compound Steam-engine. (Science Series No. 8.) 16mo,	
Turner, H. Worsted Spinners' Handbook.....	12mo, *2 00
Turrill, S. M. Elementary Course in Perspective.....	12mo, *1 25
Twyford, H. B. Purchasing.....	8vo, *3 00
Tyrrell, H. G. Design and Construction of Mill Buildings.	8vo, *4 00
— Concrete Bridges and Culverts.....	16mo, leather, *3 00
— Artistic Bridge Design.....	8vo, *3 00
Underhill, C. R. Solenoids, Electromagnets and Electromagnetic Windings	12mo, *2 00
Underwood, N., and Sullivan, T. V. Chemistry and Technology of Printing Inks.....	8vo, *3 00
Urquhart, J. W. Electro-plating.....	12mo, 2 00
— Electrotyping	12mo 2 00
Usborne, P. O. G. Design of Simple Steel Bridges.....	8vo, *4 00
Vacher, F. Food Inspector's Handbook.....	12mo, *3 00
Van Nostrand's Chemical Annual. Third issue 1913. Leather. 12mo,	*2 50
— Year Book of Mechanical Engineering Data.	(In Press.)
Van Wagenen, T. F. Manual of Hydraulic Mining.....	16mo, 1 00
Vega, Baron, Von. Logarithmic Tables.....	8vo, cloth, 2 00
	half mor., 2 50
Vincent, C. Ammonia and its Compounds. Trans. by M. J. Salter	8vo, *2 00
Volk, C. Haulage and Winding Appliances.....	8vo, *4 00
Von Georgievics, G. Chemical Technology of Textile Fibres. Trans. by C. Salter.....	8vo, *4 50
— Chemistry of Dyestuffs. Trans. by C. Salter.....	8vo, *4 50
Vose, G. L. Graphic Method for Solving Certain Questions in Arithmetic and Algebra. (Science Series No. 16.) 16mo,	0 50
Vosmaer, A. Ozone.....	8vo, *2 50
Wabner, R. Ventilation in Mines. Trans. by C. Salter.	8vo, *4 50
Wade, E. J. Secondary Batteries.....	8vo, *4 00

Wadmore, J. M. Elementary Chemical Theory.....	12mo,	*1 50
Wadsworth, C. Primary Battery Ignition.....	12mo,	*0 50
Wagner, E. Preserving Fruits, Vegetables, and Meat...	12mo,	*2 50
Waldram, P. J. Principles of Structural Mechanics...	12mo,	*3 00
Walker, F. Aerial Navigation.....	8vo,	2 00
— Dynamo Building. (Science Series No. 98.).....	16mo,	0 50
Walker, J. Organic Chemistry for Students of Medicine.	8vo,	*2 50
Walker, S. F. Steam Boilers, Engines and Turbines...	8vo,	3 00
— Refrigeration, Heating and Ventilation on Shipboard,	12mo,	*2 00
— Electricity in Mining.....	8vo,	*3 50
Wallis-Taylor, A. J. Bearings and Lubrication.....	8vo,	*1 50
— Aerial or Wire Ropeways.....	8vo,	*3 00
— Sugar Machinery	12mo,	*2 00
Walsh, J. J. Chemistry and Physics of Mining and Mine Ventilation	12mo,	*2 00
Wanklyn, J. A. Water Analysis.....	12mo,	2 00
Wansbrough, W. D. The A B C of the Differential Calculus,	12mo,	*1 50
— Slide Valves	12mo,	*2 00
Waring, Jr., G. E. Sanitary Conditions. (Science Series No. 31.)	16mo,	0 50
— Sewerage and Land Drainage.....		*6 00
— Modern Methods of Sewage Disposal.....	12mo,	2 00
— How to Drain a House.....	12mo,	1 25
Warnes, A. R. Coal Tar Distillation.....	8vo,	*2 50
Warren, F. D. Handbook on Reinforced Concrete.....	12mo,	*2 50
Watkins, A. Photography. (Westminster Series.).....	8vo,	*2 00
Watson, E. P. Small Engines and Boilers.....	12mo,	1 25
Watt, A. Electro-plating and Electro-refining of Metals.	8vo,	*4 50
— Electro-metallurgy	12mo,	1 00
— The Art of Soap-making.....	8vo,	3 00
— Leather Manufacture	8vo,	*4 00
— Paper Making	8vo,	3 00
Webb, H. L. Guide to the Testing of Insulated Wires and Cables	12mo,	1 00
Webber, W. H. Y. Town Gas. (Westminster Series.)...	8vo,	*2 00

Weisbach, J. A Manual of Theoretical Mechanics.....	8vo,	*6 00
— and Herrmann, G. Mechanics of Air Machinery....	8vo,	*7 50
— and Herrmann, G. Mechanics of Air Machinery....	sheep,	*7 50
— and Herrmann, G. Mechanics of Air Machinery....	8vo,	*3 75
Wells, M. B. Steel Bridge Designing.....	8vo,	*2 50
Weston, E. B. Loss of Head Due to Friction of Water in Pipes,		
	12mo,	*1 50
Wharen, G. B., and Yoder, J. H. Locomotive Valves and		
Valve Gears.....		(In Press.)
Wheatley, O. Ornamental Cement Work.....	8vo,	*2 00
Whipple, S. An Elementary and Practical Treatise on Bridge		
Building	8vo,	3 00
White, C. H. Methods in Metallurgical Analysis. (Van		
Nostrand's Textbooks.)	12mo,	2 50
White, G. F. Qualitative Chemical Analysis.....	12mo,	*1 25
White, G. T. Toothed Gearing.....	12mo,	*1 25
Wilcox, R. M. Cantilever Bridges. (Science Series No. 25.)		
	16mo,	0 50
Wilda, H. Steam Turbines. Trans. by C. Salter....	12mo,	1 25
— Cranes and Hoists. Trans. by Chas. Salter....	12mo,	1 25
Wilkinson, H. D. Submarine Cable Laying and Repairing.	8vo,	*6 00
Williamson, J. Surveying.....	8vo,	*3 00
Williamson, R. S. On the Use of the Barometer.....	4to,	15 00
— Practical Tables in Meteorology and Hypsometry.	4to,	2 50
Wilson, F. J., and Heilbron, I. M. Chemical Theory and Cal-		
culations	12mo,	*1 00
Wilson, J. F. Essentials of Electrical Engineering.....	8vo,	2 50
Wimperis, H. E. Internal Combustion Engine.....	8vo,	*3 00
— Application of Power to Road Transport.....	12mo,	*1 50
— Primer of Internal Combustion Engine.....	12mo,	*1 00
Winchell, N. H., and A. N. Elements of Optical Mineralogy.	8vo,	*3 50
Winslow, A. Stadia Surveying. (Science Series No. 77.)	16mo,	0 50
Wisser, Lieut. J. P. Explosive Materials. (Science Series No.		
70.).....	16mo,	0 50
Wisser, Lieut. J. P. Modern Gun Cotton. (Science Series No.		
89.).....	16mo,	0 50
Wolf, C. E. Modern Locomotive Practice.....	8vo,	*4 20

Wood, De V. Luminiferous Aether. (Science Series No. 85.)	16mo,	0 50
Wood, J. K. Chemistry of Dyeing. (Chemical Monographs No. 2.)12mo,	*0 75
Worden, E. C. The Nitrocellulose Industry. Two vols.	.8vo,	*10 00
— Technology of Cellulose Esters. In 10 vols.8vo.	
Vol. VIII. Cellulose Acetate.....		*5 00
Wren, H. Organometallic Compounds of Zinc and Magnesium. (Chemical Monographs No. 1.)12mo,	*0 75
Wright, A. C. Analysis of Oils and Allied Substances8vo,	*3 50
— Simple Method for Testing Painter's Materials8vo,	*2 50
Wright, F. W. Design of a Condensing Plant12mo,	*1 50
Wright, H. E. Handy Book for Brewers8vo,	*5 00
Wright, J. Testing, Fault Finding, etc. for Wiremen (Installation Manuals Series)16mo,	*0 50
Wright, T. W. Elements of Mechanics8vo,	*2 50
— and Hayford, J. F. Adjustment of Observations8vo,	*3 00
Wynne, W. E., and Spraragen, W. Handbook of Engineering Mathematics12mo, leather,	*2 00
Young, J. E. Electrical Testing for Telegraph Engineers	...8vo,	*4 00
Zahner, R. Transmission of Power. (Science Series No. 40.)	16mo,	
Zeidler, J., and Lustgarten, J. Electric Arc Lamps8vo,	*2 00
Zeuner, A. Technical Thermodynamics. Trans. by J. F. Klein. Two Volumes8vo,	*8 00
Zimmer, G. F. Mechanical Handling and Storing of Materials,	4to,	*12 50
Zipser, J. Textile Raw Materials. Trans. by C. Salter8vo,	*5 00
Zur Nedden, F. Engineering Workshop Machines and Processes. Trans. by J. A. Davenport8vo,	*2 00

D. VAN NOSTRAND COMPANY

are prepared to supply, either from
their complete stock or at
short notice,

Any Technical or Scientific Book

In addition to publishing a very large and varied number of SCIENTIFIC AND ENGINEERING BOOKS, D. Van Nostrand Company have on hand the largest assortment in the United States of such books issued by American and foreign publishers.

All inquiries are cheerfully and carefully answered and complete catalogs sent free on request.

25 PARK PLACE

NEW YORK



THIS BOOK IS DUE ON THE LAST DATE
STAMPED BELOW

AN INITIAL FINE OF 25 CENTS
WILL BE ASSESSED FOR FAILURE TO RETURN
THIS BOOK ON THE DATE DUE. THE PENALTY
WILL INCREASE TO 50 CENTS ON THE FOURTH
DAY AND TO \$1.00 ON THE SEVENTH DAY
OVERDUE.

FEB 28 1933

SEP 24 1940

MAY 21 1948

LD 21-50m-1,'81

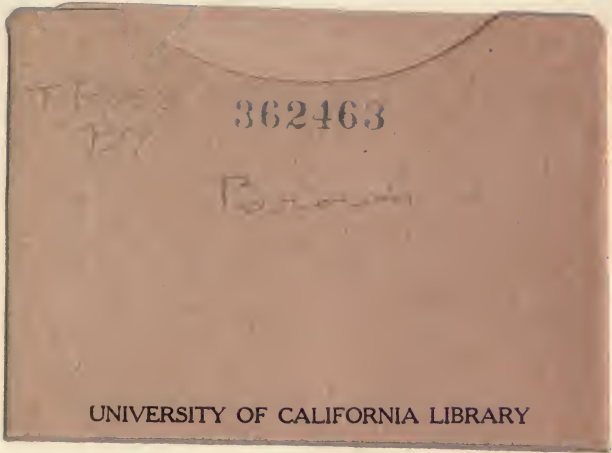

T. H. ...

362463

Brown

UNIVERSITY OF CALIFORNIA LIBRARY

