

EX LIBRIS















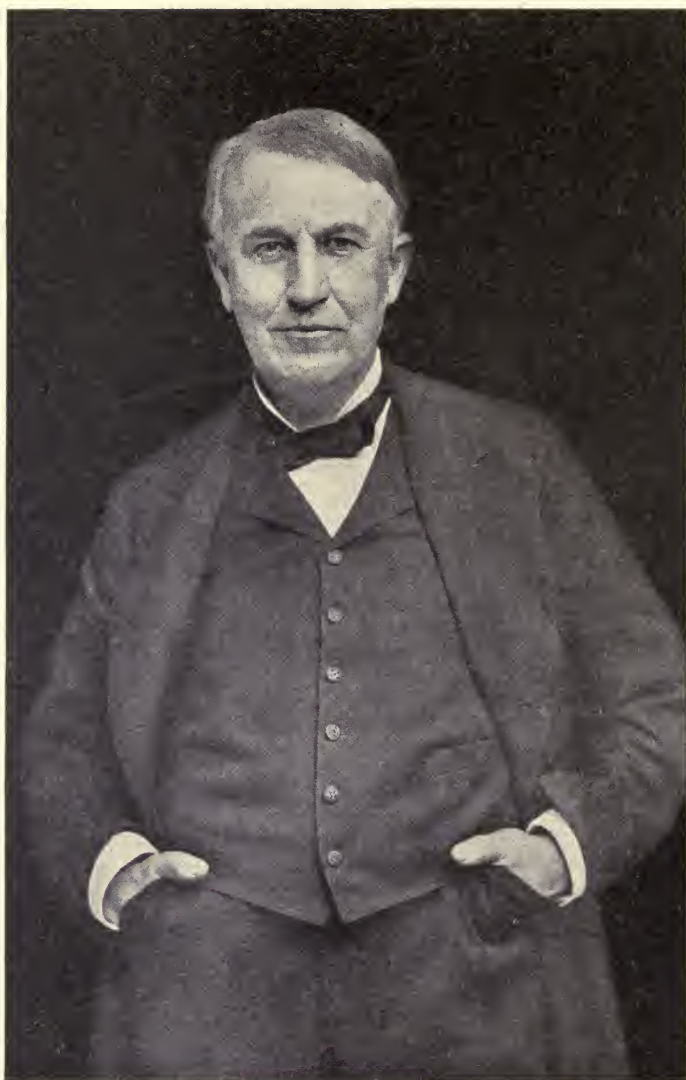

**THOMAS A. EDISON,**

Inventor of Telegraphic Appliances, Phonograph,  
Incandescent Lamp, and Many Other Electrical Devices

man

# Power Stations *and* Power Transmission

*A Manual of*

APPROVED AMERICAN PRACTICE IN THE CONSTRUCTION, EQUIPMENT,  
AND MANAGEMENT OF ELECTRICAL GENERATING STATIONS,  
SUBSTATIONS, AND TRANSMISSION LINES, FOR  
POWER, LIGHTING, TRACTION, ELECTRO-  
CHEMICAL, AND DOMESTIC USES

PART I—POWER STATIONS  
PART II—POWER TRANSMISSION

*By* GEORGE C. SHAAD, E.E.  
Assistant Professor of Electrical Engineering, Massachusetts  
Institute of Technology

ILLUSTRATED



CHICAGO  
AMERICAN SCHOOL OF CORRESPONDENCE  
" 1908 "

TK1191  
A5

**GENERAL**

*Mc*

COPYRIGHT 1907 BY  
AMERICAN SCHOOL OF CORRESPONDENCE

---

Entered at Stationers' Hall, London  
All Rights Reserved

## Foreword

---



IN recent years, such marvelous advances have been made in the engineering and scientific fields, and so rapid has been the evolution of mechanical and constructive processes and methods, that a distinct need has been created for a series of *practical working guides*, of convenient size and low cost, embodying the accumulated results of experience and the most approved modern practice along a great variety of lines. To fill this acknowledged need, is the special purpose of the series of handbooks to which this volume belongs.

☞ In the preparation of this series, it has been the aim of the publishers to lay special stress on the *practical* side of each subject, as distinguished from mere theoretical or academic discussion. Each volume is written by a well-known expert of acknowledged authority in his special line, and is based on a most careful study of practical needs and up-to-date methods as developed under the conditions of actual practice in the field, the shop, the mill, the power house, the drafting room, the engine room, etc.

☞ These volumes are especially adapted for purposes of self-instruction and home study. The utmost care has been used to bring the treatment of each subject within the range of the com-



mon understanding, so that the work will appeal not only to the technically trained expert, but also to the beginner and the self-taught practical man who wishes to keep abreast of modern progress. The language is simple and clear; heavy technical terms and the formulæ of the higher mathematics have been avoided, yet without sacrificing any of the requirements of practical instruction; the arrangement of matter is such as to carry the reader along by easy steps to complete mastery of each subject; frequent examples for practice are given, to enable the reader to test his knowledge and make it a permanent possession; and the illustrations are selected with the greatest care to supplement and make clear the references in the text.

¶ The method adopted in the preparation of these volumes is that which the American School of Correspondence has developed and employed so successfully for many years. It is not an experiment, but has stood the severest of all tests—that of practical use—which has demonstrated it to be the best method yet devised for the education of the busy working man.

¶ For purposes of ready reference and timely information when needed, it is believed that this series of handbooks will be found to meet every requirement.



# Table of Contents

## PART I—POWER STATIONS

### LOCATION OF STATION AND SELECTION OF SYSTEM . . . . . Page 3

Choosing Site—Provision for Future Extensions—Cost of Real Estate—Location of Substation—Factors Determining Choice of Generating and Transmission Systems—Advantages of Concentrating the Generating Plant—Size of Plant.

### STEAM AND HYDRAULIC PLANTS . . . . . Page 10

Boiler Requirements—Types of Boilers—Steam Piping—Interchangeability of Units—Size, Location, etc., of Pipes—Loss of Pressure—Superheating—Feed-Water and Feeding Appliances—Scale and Other Impurities—Feed-Pumps and Injectors—Furnaces—Natural and Mechanical Draft—Firing of Boilers—Steam Engines—Steam Turbines—Use of Water-Power—Water Turbines (Reaction and Impulse Types)—Pelton Wheel—Water-Pressure—Hydraulic Pipe Data—Head and Horse-Power—Governors—Gas Engines as Prime Movers.

### ELECTRICAL EQUIPMENT OF STATIONS . . . . . Page 36

Generators (Direct-Current, Alternating-Current, Single-Phase, Polyphase, Double-Current)—Exciters—Transformers—Storage Batteries—Switchboards and Connections—Standard Wire and Cable—Panels—Ammeters—Voltmeters—Rheostats—Circuit-Breakers—Bus-Bars—Oil Switches—Tripping Magnets—Lightning Arresters—Reverse-Current Relays—Speed-Limit Devices—Substations.

### STATION BUILDINGS, RECORDS, AND OFFICE MANAGEMENT . . . . . Page 63

Layout of Structure and Appointments—Station Records—Operating Expenses—Fixed Charges—Depreciation—Methods of Charging.

## PART II—POWER TRANSMISSION

### CONDUCTORS . . . . . Page 1

Materials Used—Temperature Coefficient—Weight—Mechanical Strength—Effects of Resistance—Current-Carrying Capacity—Insulating Covering for Wires—Annunciator Wire—Underwriter's Wire—Weatherproof Wire—Gutta-Percha and India Rubber.

### DISTRIBUTION SYSTEMS AND TRANSMISSION LINES. . . . . Page 11

Series Systems—Parallel or Multiple-Arc Systems—Feeders and Mains—Parallel and Anti-Parallel Feeding—Series-Multiple and Multiple-Series Systems—Multiple-Wire Systems—Voltage Regulation of Parallel Systems—Alternating-Current Systems (Series, Parallel)—Polyphase Systems (Two-Phase, Three-Phase)—Calculation of A. C. Lines—Wiring Formulae—Transformers—Losses—Efficiency—Regulation—Overhead Lines—Poles—Guying—Cross-Arms—Insulators—Pins—Temperature Effects—Underground Construction—Vitrified Conduit—Fibre Conduit—Manholes—Cables—Protection of Circuit.

### INDEX . . . . . Page 75

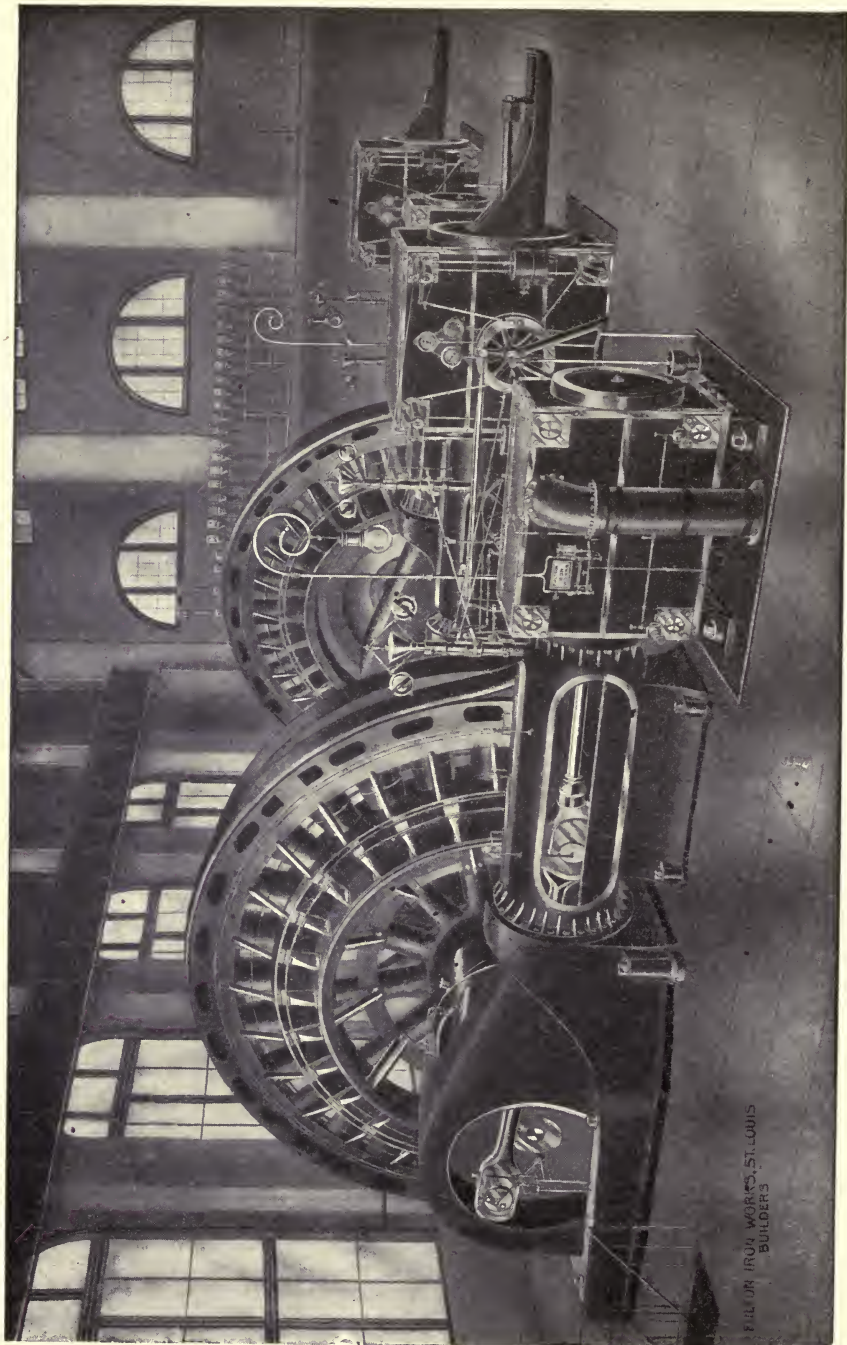

FULTON IRON WORKS, ST. LOUIS  
BUILDERS

CROSS-COMPOUND CONDENSING ENGINES DIRECT-CONNECTED TO 2,250 K.W. GENERATORS.

Fulton Iron Works.

## POWER STATIONS.

---

With the rapid increase of the use of electricity for power, lighting, traction, and electro-chemical processes, the power houses equipped for the generation of the electrical supply have increased in size from plants containing a few low-capacity dynamos, belted to their prime movers and lighting a limited district, to the modern central station, furnishing power to immense systems and over extended areas. Examples of the latter type of station are found at Niagara Falls, such stations as the Metropolitan and Manhattan stations in New York City, the plants of the Boston Edison Illuminating Company, etc.

The subject of the design, operation, and maintenance of central stations forms an extended and attractive branch of electrical engineering. The design of a successful station requires scientific training, extensive experience, and technical ability. Knowledge of electrical subjects alone will not suffice, as civil and mechanical engineering ability is called into play as well, while ultimate success depends largely on financial conditions. Thus, with unlimited capital, a station of high economy of operation may be designed and constructed, but the business may be such that the fixed charges for money invested will more than equal the difference between the receipts of the company and the cost of the generation of power alone. In such cases it is better to build a cheaper station and one not possessing such extremely high economy, but on which the fixed charges are so greatly reduced that it may be operated at a profit to the owners.

The designing engineer should be thoroughly familiar with the nature and extent of the demand for power and with the probable increase in this demand. Few systems can be completed for their ultimate capacity at first and, at the same time, operated economically. Only such generating units, with suitable reserve capacity, as are necessary to supply the demand should be installed at first, but all apparatus should be arranged in such a manner that future extensions can be readily made.



The subjects of power stations, as here treated, will consider the following general topics :

Location of station and substation, with choice of system to be employed.

Steam plants, boilers, piping, prime movers, etc.

Hydraulic plants.

The use of other prime movers.

The electrical plant, generators, and exciters, switching apparatus, etc.

Buildings.

Station records, methods of charging for power, etc.

### LOCATION OF THE GENERATING STATION.

The choice of a site for the generating station is very closely connected with the selection of the system to be used, which system, in turn, depends largely on the nature of the demand, so that it is a little difficult to treat these topics separately. Several possible sites are often available, and we may either consider the requirements of an ideal location, selecting the available one which is nearest to this in its characteristics, or we may select the best system for a given area and assume that the station may be located where it would be best adapted to this system. Wherever the site may be, it is possible to select an efficient system, though not always an ideal one.

The following points should be considered in the location of a station, no matter what the system used :

1. Accessibility.
2. Water supply.
3. Stability of foundation.
4. Surroundings.
5. Facility for extension.
6. Cost of real estate.

The station should be readily accessible on account of the delivery of fuel and stores, and of the machinery, while it should be so located that ashes and cinders may be easily removed. If possible, the station should be located so as to be reached by both rail and water, though the former is generally more desirable. If the coal can be delivered to the bunkers directly from the cars, the very important item of the cost of handling fuel may be greatly reduced. Again, the station should be in such a location that it may be readily reached by the workmen.

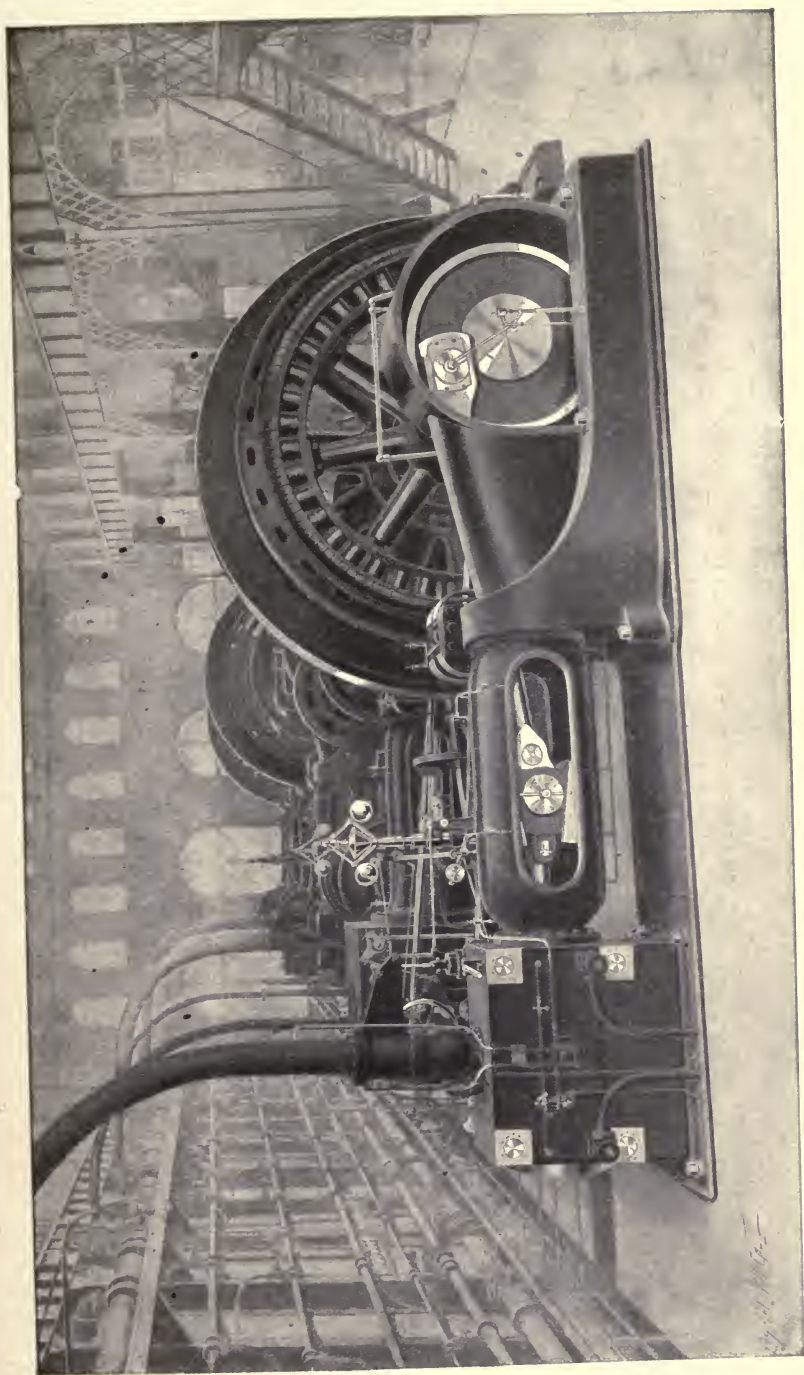

THREE 2,500- H. P. CROSS-COMPOUND CONDENSING CORLISS ENGINES,  
OPERATING THREE-PHASE A. C. GENERATORS IN PARALLEL.  
C. & G. Cooper Company.





Cheap and abundant water supply for both boilers and condensers is of utmost importance in locating a steam station. The quality of the water supply for the boiler is of more importance than the quantity. It should be as free as possible from impurities which are liable to corrode the boilers, and for this reason water from the town mains is often used, even when other water is available, as it is possible to economize in the use of water by the selection of proper condensers. The supply for condensing purposes should be abundant, otherwise it is necessary to install extensive cooling apparatus which is costly and occupies much space.

The machinery, as well as the buildings, must have stable foundations, and it is well to investigate the availability of such foundations when selecting the site.

In the operation of a power plant using coal or other fuels, certain nuisances arise, such as smoke, noise, or vibration, etc. For this reason it is preferable to locate where there is little liability to complaint on account of these causes, as some of these nuisances are costly and difficult or even impossible to prevent.

A station should be located where there are ample facilities for extension and, while it may not always be advisable to purchase land sufficient for these extensions at first, if there is the slightest doubt in regard to being able to purchase it later, it should be bought at once, as the station should be as free as possible from risk of interruption of its plans. Often real estate is too high for purchasing a site in the best location, and then the next best point must be selected. A consideration of all the factors involved is necessary in determining whether or not this cost is too high. In densely populated districts it is necessary to economize greatly with the space available, but it is generally desirable that the machinery may all be placed on the ground floor and that adequate provision may be made for the storage of fuel, etc.

The location of substations is usually fixed by other conditions than those which determine the site of the main power house. Since, in the simple rotary converter substation, neither fuel or water are necessary and there is little noise or vibration, it may be located wherever the cost of real estate will permit, provided suitable foundation may be constructed. The distance

between substations depends entirely on the selection of the system and the nature of the service.

Where low voltages are used it is essential that the station be located as near the center of the system as possible. This center is located as follows:

Having determined the probable loads and their points of application for the proposed system, these loads are indicated on a drawing with the location of the same shown to scale. The center of gravity of this system, considering each load as a weight, is then found and its location is the ideal location, as regards amount of copper necessary for the distributing system.

Consider Fig. 1, which shows the location of five different loads, which in this case are indicated by number of amperes. Combining loads A and B, we have  $Ax = By$ .  $x + y = a$ . Solv-

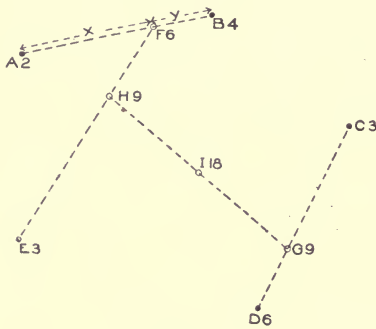

Fig. 1.

ing these equations we find that A and B may be considered as a load of  $A + B$  amperes at F. Similarly, C and D, E and F, and G and H may be combined giving us I, the center of the system. The amount of copper necessary for a given regulation runs up very rapidly as the distance of the station from this point increases.

**Selection of System.** General rules only can be stated for the selection of a system to be used in any given territory for a certain class of service.

For an area not over two miles square and a site reasonably near the center, for lighting and ordinary power purposes, direct-current, low-pressure, three-wire systems may be used. Either 220 or 440 volts may be used as a maximum voltage, and motors should, preferably, be connected across the outside wires of the circuits. Five-wire systems with 440 volts maximum potential have been used, but they require very careful balancing of the load if the service is to be satisfactory. 220-volt lamps are giving good satisfaction; moderate-size, direct-current motors may be readily built for this pressure and constant-potential arc lamps may be operated

on this voltage though not so economically as on 110 volts, if single lamps are used. For direct-current railway work, the limit of the distance to which power may be economically delivered with an initial pressure of 600 volts is from five to seven miles, depending on the traffic.

If the area to be served is materially larger than the above, or distances for direct-current railways greater, either of two different schemes may be adopted. Several stations may be located in the territory and operated separately or in multiple on the various loads, or one large power house may be erected and the energy transmitted from this station at a high voltage to various transformers or transformer substations which, in turn, transform the voltage to one suitable for the receivers. Local conditions usually determine which of these two shall be used.

The use of several low-tension stations operating in multiple is recommended only under certain conditions, namely, that the demand is very heavy and fairly uniformly distributed throughout the area, and suitable sites for the power house can be readily obtained. Such conditions rarely exist and it is a question whether or not the single station would not be just as suitable for such cases as where the load is not so congested.

One reason why a large central station is preferred to several smaller stations is that large stations can be operated more economically, owing to the fact that large units may be used and they can be run more nearly at full load. There is a gain in the cost of attendance, and labor-saving devices can be more profitably installed. The location of the power plant is not determined to such a large extent by the position of the load, but other conditions, such as water supply, cheap real estate, etc., will be the governing factors. In several cities, notably New York and Boston, large central stations are being installed to take the place of several separate stations, the old stations being changed from generating power houses to rotary-converter substations. Both direct-current low-tension machines, to supply the neighboring districts, and high-tension alternating-current, for supplying the outlying or residence districts, are often installed in the one station.

As examples of the central station being located at some distance from the center of the load, we have nearly all of the large

hydraulic power developments. Here it is the cheapness of the water power which determines the power house location. The greatest distance over which power is transmitted electrically at present is in the neighborhood of 200 miles.

If a high-tension alternating-current system is to be installed, there remains the choice of a polyphase or single-phase machine as well as the selection of voltage for transmission purposes. As pointed out in "Power Transmission", polyphase generators are cheaper than single-phase generators and, if necessary, they can be loaded to about 80% of their normal capacity, single-phase, while motors can be more readily operated from polyphase circuits. If synchronous motors or rotary converters are to be installed, a polyphase system is necessary. The voltage will be determined by the distance of transmission, care being taken to select a value considered as standard, if possible. Generators are wound giving a voltage at the terminals as high as 15,000 volts, but in many districts it is desirable to use step-up transformers for voltages above 6,600 on account of liability to troubles from lightning.

With the development of the single-phase railway motor, central stations generating single-phase current only, will be built in larger sizes than previously, as their use heretofore has been limited to lighting stations.

**Size of Plant.** A few general notes in regard to the design of plants will be given here, the several points being taken up more in detail later.

Direct driving of apparatus is always superior to methods of gearing or belting as it is efficient, safe, and reliable, but it is not as flexible as shafting and belts. and on this account its adoption is not universal.

Speeds to be used will depend on the type and size of the generating unit. Small machines are always cheaper when run at high speeds, but the saving is less on large generators. For large engines, slow speed is always preferable.

It is desirable that there be a demand for both power and lighting, and a station should be constructed which will serve both purposes. The use of power will create a day load for a lighting station which does much to increase its ultimate efficiency and, as a rule, its earning capacity.



In addition to generator capacity necessary to supply the load, a certain amount of reserve, either in the way of additional units or overload capacity, must be installed. The probable load for say three years can be closely estimated and this, together with the proper reserve, will determine the size of the station. The plant as a whole, including all future extensions, should be planned at the start as extensions will then be greatly facilitated. Usually it will not be desirable to begin extensions for at least three years after the first part of the plant has been erected.

Enough units must be installed so that one or more may be laid off for repairs, and there are several arguments in favor of making this reserve in the way of overload capacity, for the generators at least. Some of these arguments are: Reserve is often required at short notice, notably in railway plants. With overload capacity, rapid increase of load, such as occurs in lighting stations when darkness comes on suddenly, may be more readily taken care of. There is always a factor of safety in machines not running to their fullest capacity. Reserve capacity is cheaper in this form than if installed as separate machines. As a disadvantage, we have a lower efficiency, due to machines not usually running at full load, but in the case of generators this is very slight.

With an overload capacity of  $33\frac{1}{3}\%$ , four machines should be the initial installment since one can be laid off for repairs if necessary, the total load being readily carried by three machines. In planning extensions, the fact that at least one machine may require to be laid off at any time should not be lost sight of, while the units should be made as large as is conducive to the best operation.

TABLE 1.  
Permissible Overload 33 per cent.

	Machines added one at a time.		Machines added two at a time.		Machines added three at a time.	
	No.	Size.	No.	Size.	No.	Size.
Initial installment.....	4	500	4	500	4	500
First extension.....	1	666	2	1000	3	2000
Second ".....	1	838	2	2000	5	5000
Third ".....	1	1183	2	4000	4	5000
Fourth ".....	1	1577	4	4000		
Fifth ".....	1	2103	8	4000		
Sixth ".....	1	2304				

Table I is worked out showing the initial installment for a 2,000-K.W. plant with future extensions. It is seen from this table that adding two machines at a time gives more uniformity in the size of units—a very desirable feature.

The boilers should be of large units for stations of large capacity, while for small stations they must be selected so that at least one may be laid off for repairs.

## STEAM PLANT.

### BOILERS.

The majority of power stations have their machinery driven by either steam or water power, though there are many using gas engines as prime movers. If a steam plant is being considered, one of the first subjects to be taken up is the generation of the steam. The subject of boilers is one of vital importance to the successful operation of steam-driven central stations. The object of the boiler with its furnace is to abstract as much heat as possible from the fuel and impart it to the water. The various kinds of boilers used for accomplishing this more or less successfully are described in books on boilers, and we will consider here the merits of a few of the types only as regards central-station operation.

The requirements are: *First*, that steam be available throughout the twenty-four hours; the amount required at different parts of the day varying considerably. Thus, in a lighting station, the demand from midnight to 6 a. m. is very light, but toward evening, when the load on the station increases very rapidly, there is an abrupt increase in the rate at which steam must be given off. The maximum demand can be readily anticipated under normal weather conditions, but occasionally this maximum will be equaled or even exceeded at unexpected moments. For this reason a certain number of boilers must be kept under steam constantly, more or less of them running with banked fires during light loads. If the boilers have a small amount of radiating surface, the loss during idle hours will be decreased.

*Second*, the boilers must be economical over a large range of rates of firing and must be capable of being forced without detriment. Boilers should be provided which work economically for the hours just preceding and following the maximum load while they

may be forced, though running at lower efficiency, during the peak.

*Third*, coming to the commercial side of the question, we have first cost, cost of maintenance, and space occupied. The first cost, as does the cost of maintenance, varies with the type and pressure of the boiler. The space occupied enters as a factor only when the situation of the station is such that space is limited, or when the amount of steam piping becomes excessive. In some city plants, space may be the determining feature in the selection of boilers.

The **Cornish and Lancashire** boilers differ only in the number of cylindrical tubes in which furnaces are placed. As many as three tubes are placed in the largest sizes (seldom used) of the Lancashire boilers. They are made up to 200 pounds steam pressure and possess the following features:

1. High efficiency at moderate rates of combustion.
2. Low rate of depreciation.
3. Large water space.
4. Easily cleaned.
5. Large floor space required.
6. Cannot be readily forced.

The Galloway boiler differs from the Lancashire boiler in that there are cross tubes in the flues.

In the **Multitubular boiler** the number of tubes is greatly increased and their size diminished. Their heating surface is large and they steam rapidly. They are used extensively for power-station work.

The chief characteristics of the **water-tube boilers**, of which there are many types, are:

1. Moderate floor space.
2. Ability to steam rapidly.
3. Good water circulation.
4. Adapted to high pressure.
5. Easily transported and erected.
6. Easily repaired.
7. Not easily cleaned.
8. Rate of deterioration greater than for Lancashire boiler.
9. Small water space, hence variation in pressure with varying demands for steam.
10. Expensive setting.

**Marine boilers** require no setting. Among their advantages and disadvantages may be mentioned:



1. Exceedingly small space necessary.
2. Radiating surface reduced.
3. Good economy.
4. Heavy and difficult to repair.
5. Unsuitable for bad water.
6. Poor circulation of water.

Another type of boiler, known as the Economic, is a combination of the Lancashire and multitubular boilers, as is the marine boiler. It is set in brickwork and arranged so that the gases pass under the bottom and along the sides of the boiler as well as through the tubes. It may be compared with other boilers from the following points:

1. Small floor space.
2. Less radiating surface than the Lancashire boiler.
3. Not easily cleaned.
4. Repairs rather expensive.
5. Requires considerable draft.

As regards first cost, boilers installed for 150 pounds pressure and the same rate of evaporation, will run in the following order: Galloway and Marine, highest first cost, Economic, Lancashire, Babcock & Wilcox. The increase of cost, with increase of steam pressure, is greatest for the Economic and least for the water-tube type.

Deterioration is less with the Lancashire boiler than with the other types.

The floor space occupied by these various types built for 150 pounds pressure and 7,500 pounds of water, evaporated per hour, is given in Table 2.

TABLE 2.

Kind of Boiler.	Floor Space in Sq. Ft.
Lancashire .....	408
Galloway .....	371
Babcock and Wilcox .....	200
Marine wet-back .....	120
Economic .....	210

The percentage of the heat of the fuel utilized by the boiler is of great importance, but it is difficult to get reliable data in regard to this. Table 3 is taken from Donkin's "Heat Efficiency of Steam Boilers", and will give some idea of the efficiencies of the different types. Economizers were not used in any of these tests, but they should always be used with the Lancashire type of boiler.

TABLE 3.

Kind of Boiler.	No. of Experiments.	Mean Efficiency of two best Experiments.	Lowest Efficiency.	Mean Efficiency of all Experiments.
Lancashire hand-fired .....	107	79.5	42.1	62.3
Lancashire machine-fired .....	40	73.0	51.9	64.2
Cornish hand-fired .....	25	81.7	53.0	68.0
Babcock and Wilcox hand-fired...	49	77.5	50.0	64.9
Marine wet-back hand-fired .....	6	69.6	62.0	66.0
Marine dry-back hand-fired .....	24	75.7	64.7	69.2

It is well to select a boiler from 20 to 50 pounds in excess of the pressure to be used, as its life may thus be considerably extended, while, when the boiler is new, the safety valve need not be set so near the normal pressure, and there is less steam wasted by the blowing off of this valve. Again, a few extra pounds of steam may be carried just previous to the time the peak of the load is expected. For pressures exceeding 200 or, possibly, 150 pounds, a water-tube boiler should be selected.

In large stations, it is preferable to make the boiler units of large capacity, to do away as much as possible with the extra piping and fittings necessary for each unit. Water-tube boilers are best adapted for large sizes. These may be constructed for 150 pounds pressure, large enough to evaporate 20,000 pounds of water per hour, at an economical rate.

To sum up—For stations of moderate size and with medium pressures with plenty of space, use Lancashire or fire-tube boilers; for high pressure or large units, select water-tube boilers; where space is limited, install marine boilers, although they are not as safe as water-tube boilers for high pressures.

**Steam Piping.** The piping from the boilers to the engines should be given very careful consideration. Steam should be available at all times and for all engines. Freedom from serious interruptions due to leaks or breaks in the piping is brought about by very careful design and the use of good material in construction. Duplicate piping is used in many instances. Provision must always be made for variations in length of the pipe with variation of temperature. For plants using steam at 150 pounds pressure, the variation in the length of steam pipe may be as high as 2.5

inches for 100 feet, and at least 2 inches for 100 feet should always be counted upon.

**Arrangement.** Fig. 2 shows a simple diagram of the "ring" system of piping. The steam passes from the boiler by two paths to the engine and any section of the piping may be cut out by

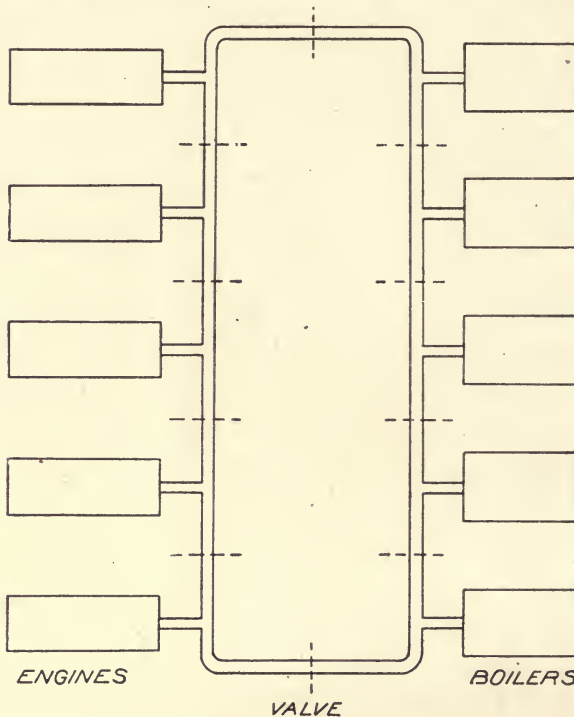

Fig. 2.

the closing of two valves. Simple ring systems have the following characteristics:

1. The range, as the main pipe is called, must be of uniform size and large enough to carry all of the steam when generated at its maximum rate.
2. A damaged section may disable one boiler or one engine.
3. Several large valves are required.
4. Provision may be readily made to allow for expansion of pipes.

Cross connecting the ring system, as shown in Fig. 3, changes these characteristics as follows:

1. Size of pipes and consequent radiating surface is reduced.
2. More valves needed but they are of smaller size.
3. Less easy to arrange for expansion of the pipes.

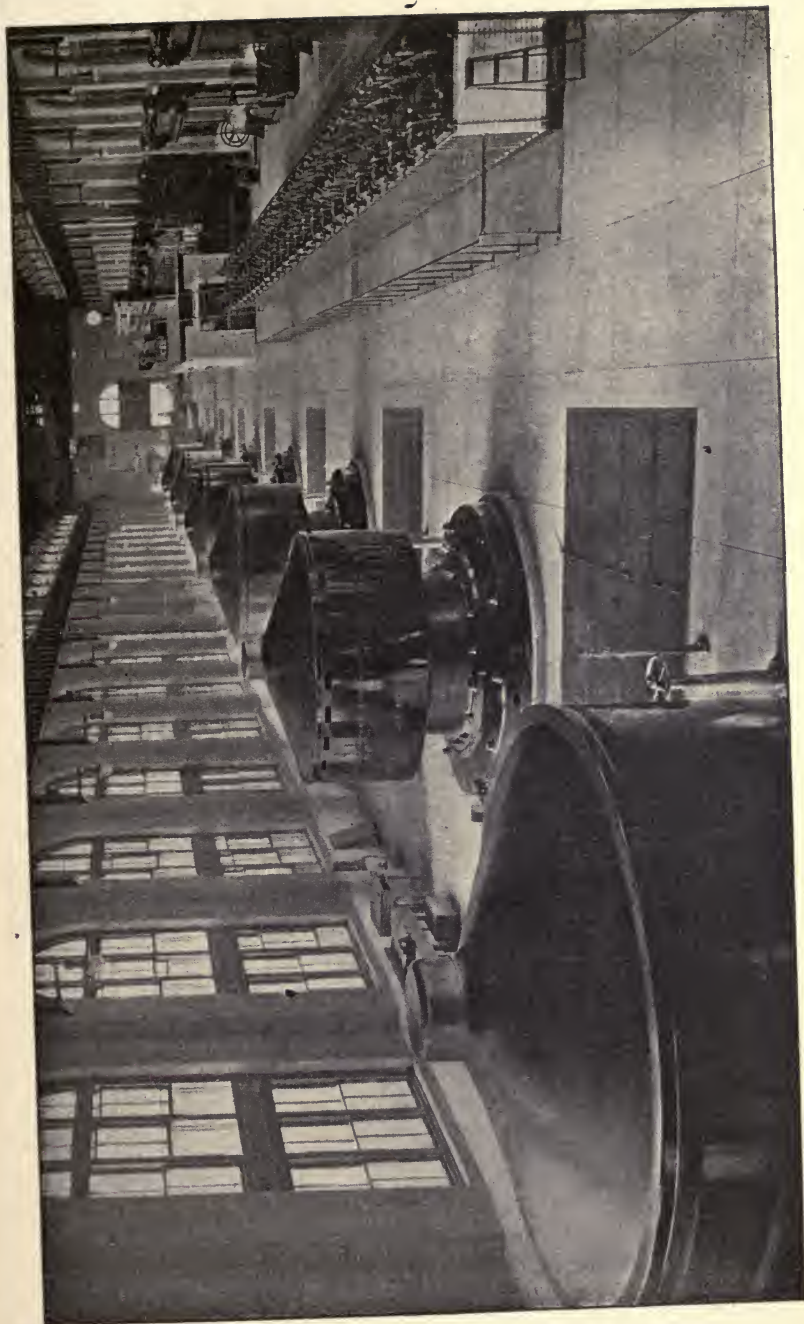

**POWER HOUSE NO. 2, NIAGARA FALLS POWER CO.**

Eleven Generators of 5,000 H.P. Each.





If the system is to be duplicated, that is, two complete sets of main pipes and feeders installed (see Fig. 4), two schemes are in use:

1. Each system is designed to operate the whole station at maximum load with normal velocity and loss of pressure in the pipes, and only one system is in use at a time. This has the disadvantage that the idle

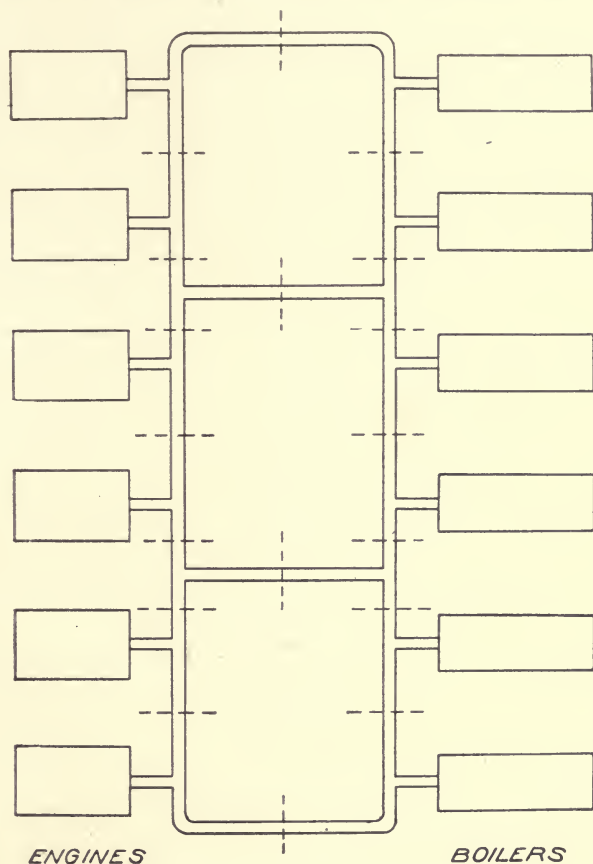

Fig. 3.

section is liable not to be in good operating condition when needed. Large pipes must be used for each set of mains.

2. The two systems may be made large enough to supply steam at normal loss of pressure when both are used at the same time, while either is made large enough to keep the station running should the other section need repairs. This has the advantages of less expense, and both sections of pipe are normally in use; but it has the disadvantages of more radiating surface to the pipes and consequent condensation for the same capacity for furnishing steam.

Complete interchangeability of units cannot be arranged for if the separate engine units exceed 400 to 500 horse power. Since engine units can be made larger than boiler units, it becomes necessary to treat several boiler units as a single unit, or battery, these batteries being connected as the single boilers already shown. For still larger plants the steam piping, if arranged to supply any engines from any batteries of boilers, would be of enormous size. If the boilers do not occupy a greater length of floor space than the engines, Fig. 5 shows a good arrangement of units. Any

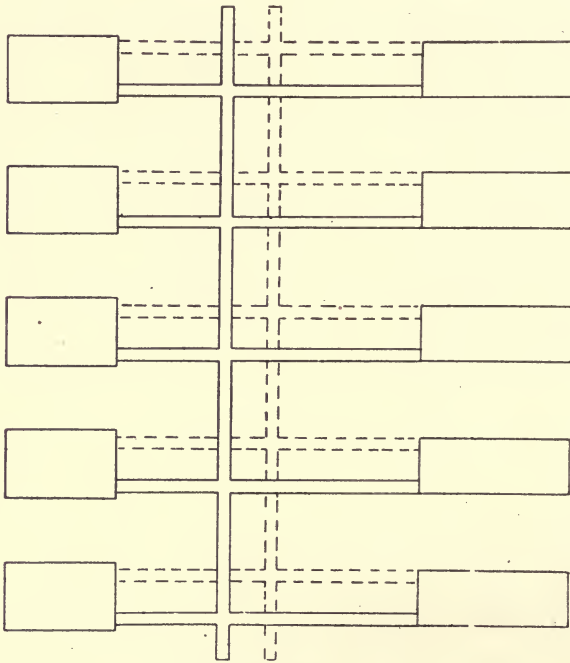

Fig. 4.

engine can be fed from either of two batteries of boilers and the liability of serious interruptions of service due to steam pipes or boiler trouble is very remote.

**Material.** Steel pipe, lap welded and fastened together by means of flanges, is to be recommended for all steam piping. The flanges may be screwed on the ends of sections and calked so as to render this connection steam tight, though in large sizes it is better to have the flanges welded to the pipes. This latter construction



costs no more for large pipes and is much more reliable. All valves and fittings are made in two grades or weights, one for low pressures, and the other for high pressures. The high-pressure fittings should always be used for electrical stations. Gate valves should always be selected and, in large sizes, they should be provided with a by-pass.

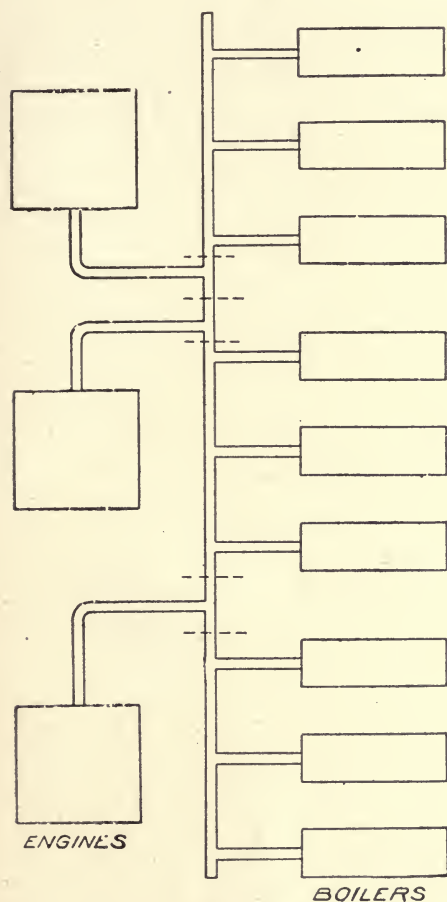

Fig. 5.

Asbestos, either alone or with copper rings, vulcanized india rubber, asbestos and india rubber, etc., are used for packing between flanges to render them steam tight. Where there is much expansion, the material selected should be one that possesses considerable elasticity. Joints for high-pressure systems require much more care than those where steam is used at a low pressure, and the number of joints should be reduced to a minimum by using long sections of pipe.

A list of the various fittings required for steam piping, together with their descriptions, is given in books on boilers. One precaution to be taken is to see that such fittings do not become too numerous or complicated, and it is well not to depend too much

on automatic fittings. Steam separators should be large enough to serve as a reservoir of steam for the engine and thus equalize, to a certain extent, the velocity of flow of steam in the pipes.

In providing for the expansion of pipes due to change of temperature, "U" bends made of steel pipe and having a radius of curvature not less than six times, and preferably ten times the diameter of the pipe, are preferred. Copper pipes cannot be recommended for high pressures, while slip expansion joints are most undesirable on account of their liability to bind.

The size of steam pipes is determined by the velocity of flow. Probably an average velocity of 60 feet per second would be better than 100 feet per second, though in some cases where space is limited a velocity as high as 150 feet per second has been used.

The loss in pressure in steam pipes may be obtained from the following formula:

$$p_1 - p_2 = \frac{Q^2 w L}{c^2 d^5}$$

where  $p_1 - p_2$  = loss in pressure in pounds per sq. in.

Q = quantity of steam in cu. ft. per minute.

d = diameter of pipe in inches.

L = length in feet.

w = weight per cu. ft. of steam at pressure  $p_1$ .

c = constant depending on size of pipe.

Values of  $c$  are as follows:

Diameter of pipe..	½"	1"	2"	3"	4"	5"	6"	7"	8"	9"	10"
Value of $c$ .....	36.8	45.3	52.7	56.1	57.8	58.4	59.5	60.1	60.7	61.2	61.8
Diameter of pipe.....				12"	14"	16"	18"	20"	22"	24"	
Value of $c$ .....				62.1	62.3	62.6	62.7	62.9	63.2	63.2	

In mounting the steam pipe, it should be fastened rigidly at one point, preferably near the center of a long section, and allowed a slight motion longitudinally at all other supports. Such supports may be provided with rollers to allow for this motion, or the pipe may be suspended from wrought-iron rods which will give a flexible support. Practice differs in the location of the steam piping, some engineers recommending that it be placed underneath the engine room floor and others that it be located high above the engine room floor. In any case it should be made easily accessible, and the valves should be located so that nothing will interfere with their operation. Proper provision must be made for draining the pipes.

All piping as well as joints should be carefully covered with a good quality of lagging as the amount of steam condensed in a bare pipe, especially if of any great length, is considerable. In selecting a lagging the following points should be noticed. Covering for steam pipes should be incombustible, should present a smooth surface, should not be easily damaged by vibration or steam, and should have as large a resistance to the passage of heat as possible. It must not be too thick, otherwise the increased radiating surface will counterbalance the resistance to the passage of heat.

The loss of power in steam pipes due to radiation is given as follows:

$$H = .262rLd.$$

$H$  = loss of power in heat units.

$d$  = diameter of pipe.

$L$  = length of pipe in feet.

$r$  = constant depending on steam pressure and pipe covering.

Steam pressure in pounds (absolute) .....	40	65	90	115
Values of $r$ for uncovered pipe .....	437	555	620	684
Value of $r$ for pipe covered with 2 inches of hair felt .....	48	58	66	73

Referring to table in books on boilers, the relative values of different materials used for covering steam pipes may be found.

**Superheated Steam** reduces condensation in the engines as well as in the piping, and increases the efficiency of the system. Its use was abandoned for several years, due to difficulties in lubricating and packing the engine cylinders, but by the use of mineral oils and metallic packing, these difficulties have been done away with to a large extent, while steam turbines are especially adapted to the use of superheated steam. The application of heat directly to steam, as is done in the superheater, increases the efficiency of the boilers. Table 4 shows the increase in boiler efficiency for a certain boiler test, the results being given in pounds of water changed to dry, saturated steam. Tests on various engines show a gain in efficiency as high as 9% with a superheat of 80° to 100° F, while special tests in some cases show even a greater gain.

TABLE 4.

Amount of superheat.		Water evaporated per lb. of coal.	
		Without superheat.	With superheat.
40	degrees F.....	7.82	9.99
42	“.....	6.42	7.06
55	“.....	6.00	7.00
56.5	“.....	6.78	8.66
55.2	“.....	7.15	8.65

Superheaters are very simple, consisting of tubular boilers containing steam instead of water, and either located so as to utilize the heat of the gases, the same as economizers, or separately fired. They should be arranged so that they may be readily cut out of service, if necessary, and provision must be made for either flooding them or turning the hot gases into a by-pass, as the tubes would be injured by the heat if they contained neither water nor steam.

#### FEED WATER AND FEEDING APPLIANCES.

All water, such as can be obtained for the feeding of boilers, contains some impurities, among the most important of which as regards boilers are soluble salts of calcium and magnesium. Bicarbonates of the alkaline earths cause precipitations on the interior of boilers, forming “scale”. Sulphate of lime is also deposited by concentration under pressure. Scale, when formed, not only decreases the efficiency of the boiler but also causes deterioration, for if sufficiently thick, the diminished conducting power of the boiler allows the tubes or plates to be overheated and to crack or burst. Again, the scale may keep the water from contact with sections of the heated plates for some time and then, giving way, large volumes of steam are generated very quickly and an explosion may result.

Some processes to prevent the formation of scale are used, which affect the water after it enters the boilers, but they are not to be recommended, and any treatment the water receives should affect it previous to its being fed to the boilers. Carbonates and a small quantity of sulphate of lime may be removed by heating



in a separate vessel. Large quantities of sulphate of lime must be precipitated chemically.

Sediment, small particles of matter in suspension, must be removed by allowing the water to settle. Vegetable matters are sometimes present, which cause a film to be deposited. Certain gases, in solution—such as oxygen, nitrogen, etc.—cause pitting of the boiler. This effect is neutralized by the addition of chemicals. Oil, from the engine cylinder, is particularly destructive to boilers and when present in the condensed steam must be carefully removed.

Both feed pumps and injectors are used for feeding the water to the boilers. Feed pumps may be either steam or motor-driven. Steam-driven pumps are very inefficient, but they are simple and the speed is easily controlled. Motor-driven pumps are more efficient and

neater, but more expensive and more difficult to regulate efficiently over a wide range of speed. Direct-acting pumps may have feed-water heaters attached to them, thus increasing the efficiency of the apparatus as a whole. The supply of electrical energy must be constant if motor-driven pumps are to be used.

Feed pipes must be arranged so as to reduce the risk of failure to a minimum, and for this reason they are almost always duplicated. More than one water supply is also recommended if there is the slightest danger of interruption on this account. One common arrangement of feed-water apparatus is to install a few large pumps supplying either of two mains from which the boiler con-

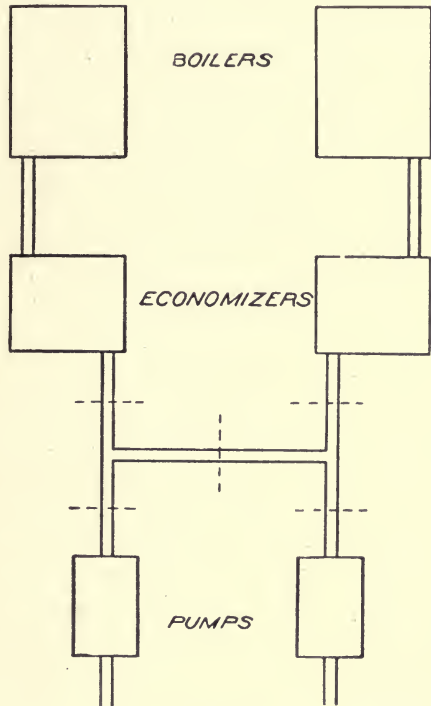

Fig. 6.

TABLE 5.

Giving Rate of Flow of Water, in Feet per Minute, through Pipes of Various Sizes, for Varying Quantities of Flow.

Gallons per Min.	$\frac{3}{4}$ in.	1 in.	$1\frac{1}{4}$ in.	$1\frac{1}{2}$ in.	2 in.	$2\frac{1}{2}$ in.	3 in.	4 in.
5	218	$122\frac{1}{2}$	$78\frac{1}{2}$	$54\frac{1}{2}$	$30\frac{1}{2}$	$19\frac{1}{2}$	$13\frac{1}{2}$	$7\frac{2}{3}$
10	436	245	157	109	61	38	27	$15\frac{1}{3}$
15	653	$367\frac{1}{2}$	$235\frac{1}{2}$	$163\frac{1}{2}$	$91\frac{1}{2}$	$58\frac{1}{2}$	$40\frac{1}{2}$	$23\frac{2}{3}$
20	872	490	314	218	122	78	54	$30\frac{2}{3}$
25	1090	$612\frac{1}{2}$	$392\frac{1}{2}$	$272\frac{1}{2}$	$152\frac{1}{2}$	$97\frac{1}{2}$	$67\frac{1}{2}$	$38\frac{2}{3}$
30		735	451	327	183	117	81	46
35		$857\frac{1}{2}$	$549\frac{1}{2}$	$381\frac{1}{2}$	$213\frac{1}{2}$	$136\frac{1}{2}$	$94\frac{1}{2}$	$53\frac{2}{3}$
40		980	628	436	244	156	108	$61\frac{1}{3}$
45		$1102\frac{1}{2}$	$706\frac{1}{2}$	$490\frac{1}{2}$	$274\frac{1}{2}$	$175\frac{1}{2}$	$121\frac{1}{2}$	69
50			785	545	305	195	135	$76\frac{2}{3}$
75			$1177\frac{1}{2}$	$817\frac{1}{2}$	$457\frac{1}{2}$	$292\frac{1}{2}$	$202\frac{1}{2}$	115
100				1090	610	380	270	$153\frac{1}{3}$
125					$762\frac{1}{2}$	$487\frac{1}{2}$	$337\frac{1}{2}$	$191\frac{2}{3}$
160					915	585	405	230
175					$1067\frac{1}{2}$	$682\frac{1}{2}$	$472\frac{1}{2}$	$268\frac{1}{3}$
200					1220	780	540	$306\frac{2}{3}$

nections are taken. This is a complicated and costly system of piping. Fig. 6 shows a scheme used for feeding two boilers in which each pump is capable of supplying both boilers. Pipes should be ample in cross-section, and, in long lengths, allowance must be made for expansion. Cast iron or cast steel is the material used for their construction, while the joints are made by means of flanges fitted with rubber gaskets.

Table 5 gives the rate of flow of water in feet per minute through pipes of various sizes. A flow of 10 gallons per minute for each 100 H. P. of boiler equipment should be allowed without causing an excessive velocity of flow in the pipes.

#### BOILER FOUNDATIONS, FURNACES AND DRAFT.

The economical use of coal depends, to a large extent, on the setting of the boiler and proper dimensions of the furnaces. Internally-fired boilers require support only, while the setting of externally-fired boilers requires provision for the furnaces. Common brick, together with fire brick for the lining of portions exposed to the hot gases, are used almost invariably for boiler settings. It is customary to set the boiler units up in batteries of two, using a 20-inch wall at the sides and a 12-inch wall between the two boilers. The instructions for settings furnished by

the manufacturers should be carefully followed out as they are based on conditions which give the best results in the operation of their boilers.

**Natural Draft** is the most commonly used and is the most satisfactory under ordinary circumstances. In determining the size of the chimney necessary to furnish this draft, the following formula is given by Kent:

$$A = \frac{.06 F}{\sqrt{h}} \text{ or } h = \left( \frac{.06 F}{A} \right)^2$$

A = area of chimney in sq. ft.

h = height of chimney in ft.

F = pounds of coal per hour.

The height of chimney should be assumed and the area calculated, remembering that it is better to have the chimney too large than too small.

The chimney may be of either brick or iron, the latter having a less first cost but requiring repairs at frequent intervals. General rules for the design of a chimney may be given as follows: The external diameter of the base should not be less than  $\frac{1}{10}$  of the height. Foundations must be of the best. Interiors should be of uniform section and lined with fire brick. There must be an air space between the lining and chimney proper. The exterior should have a taper of from  $\frac{1}{16}$  to  $\frac{1}{4}$  inch to the foot. Flues should be arranged symmetrically.

Fig. 7 shows the construction of a brick chimney of good design, this chimney being used with boilers furnishing engines which develop 14,000 H. P.

**Mechanical Draft** is a term which may be used to embrace both forced and induced draft. The different systems of mechanical draft are described in books on boilers. The first cost of mechanical-draft systems is less than that of a chimney, but the operation and repair are much more expensive and there is always the risk of break-down. Artificial draft has the advantage that it can be varied within large limits and it can be increased to any desired extent, thus allowing the use of low grades of coal.

**Firing of Boilers and Handling of Fuel.** Coal is used for fuel to a greater extent than any other material, though oil, gas,

wood, etc., are used in some localities. Local conditions, such as availability, cost, etc., should determine the material to be used and no general rules can be given.

Data regarding the relative heating values of different fuels show the following general figures: One pound of petroleum, about  $\frac{1}{7}$  of a gallon, is equivalent, when used with boilers, to 1.8 pounds of coal and there is less deterioration of the furnace with oil.  $7\frac{1}{2}$  to 12 cubic feet of natural gas are required as the equivalent of one pound of coal, depending on the quality of the gas.  $2\frac{1}{2}$  pounds of dry wood is assumed as the equivalent of one pound of coal.

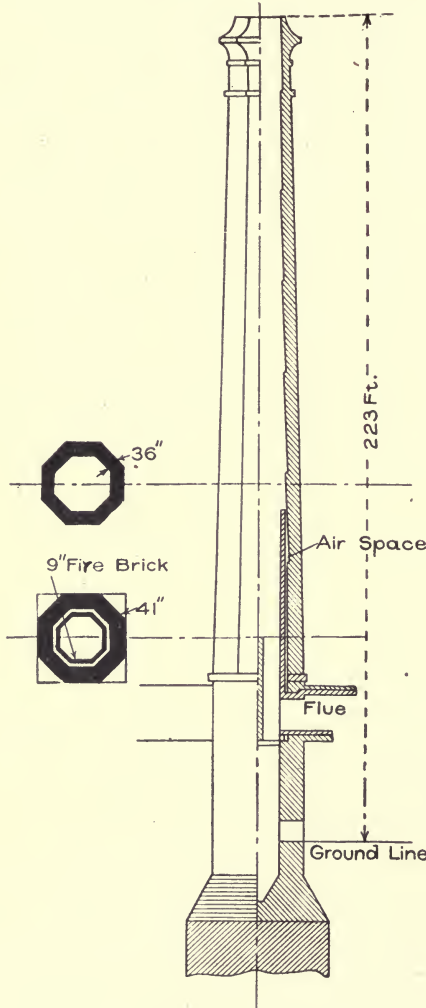

Fig. 7.

When coal is used, it requires stoking and this may be accomplished either by hand or by means of mechanical stokers, many forms of which are available. Mechanical stoking has the advantage over hand stoking that the fuel may be fed to the furnace more uniformly and the fires and boilers are not subjected to sudden blasts of cold air as is the case when the fire doors are opened; a poorer grade of coal may be burned, if necessary, and the trouble due

to smoke is much reduced. It may be said that mechanical stokers are used almost universally in the more important elec-



trical plants. Economic use of fuel requires great care in firing, especially if it is done by hand.

Where gas is used, the firing may be made nearly automatic, and the same is true of oil firing, though the latter requires more complicated burners, as it is necessary that the oil be vaporized.

In large stations, operated continuously, it is desirable that, as far as possible, all coal and ashes be handled by machinery, though the difference in cost of operation should be carefully considered before installing extensive coal-handling machinery. Machinery for automatically handling the coal will cost from \$7.50 to \$10 per horse-power rating of boilers for installation, while the ash-handling machinery will cost from \$1.50 to \$3.00 per horse power.

The coal-handling devices usually consist of chain-operated conveyors which hoist the coal from railway cars, barges, etc., to overhead bins from which it may be fed to the stokers. The ashes may be handled in a similar manner, by means of scraper conveyors, or small cars may be used. Either steam or electricity may be used for driving this auxiliary apparatus.

It is always desirable that there be generous provision for the storage of fuel sufficient to maintain operations of the plant over a temporary failure of supply.

#### STEAM ENGINES AND TURBINES.

The choice of steam prime movers is one which is governed by a number of conditions which can be treated but briefly here. The first of these conditions relates to the speed of the engine to be used. There is considerable difference of opinion in regard to this as both high and low-speed plants are in operation, which are giving good satisfaction. Slow-speed engines have a higher first cost and a higher economy. Probably in sizes up to 250 K.W. the generator should be driven by high-speed engines, above which the selection of either type will give satisfaction until sizes of say above 500 indicated horse power, when the slow-speed type is to be recommended. Drop valves cannot be used with satisfaction for speeds above about 100 revolutions per minute, hence high-speed engines must use direct-driven valve gears, usually governed by shaft governors. Corliss valves are used on nearly all slow-speed engines.

The steam pressure used should be at least 125 pounds per square inch at the throttle and a pressure as high as 150 to 160 pounds is to be preferred.

Close regulation and uniform angular velocity are required for driving generators, especially alternators which are to operate in parallel. This means sensitive and active governors, carefully designed fly-wheels and proper arrangement of cranks when more than one is used.

For large plants or plants of moderate size, compound condensing engines are almost universally installed. The advantage of these engines in increased economy are in part counterbalanced by higher first cost and increased complications, together with the pumps and added water supply necessary for the condensers. The approximate saving in amount of steam is shown in table 6, which applies to a 500 horse-power unit.

TABLE 6.

Engine.	Pounds of Steam per H. P. hour.
Simple non-condensing .....	30
Simple condensing .....	22
Compound non-condensing .....	24
Compound condensing .....	16

Triple expansion engines are seldom used for driving electrical machinery as their advantages under variable loads are doubtful. Compound engines may be tandem or cross compound and either horizontal or vertical. The use of cross-compound engines tends to produce uniform angular velocity, but the cylinder should be so proportioned that the amount of work done by each is nearly equal. A cylinder ratio of about  $3\frac{1}{2}$  to 1 will approximate average conditions. Either vertical or horizontal engines may be installed, each having its own peculiar advantages. Vertical engines require less floor space, while horizontal engines have a better arrangement of parts. Either type should be constructed with heavy parts and erected on solid foundations.

Recently steam turbines have come into use, and the number of stations at present under process of design or construction which will use steam turbines is very large. Several types of turbines are described in the books on engines. In addition to these, a

short review of the Curtis turbine will not be out of place since this is one of the types which is coming into extended use.

The Curtis turbine is divided into sections, each section of which may contain one, two, or more, revolving sets of buckets and stationary vanes supplied with steam from a set of expansion nozzles. By this arrangement of parts the work is divided into stages, the nozzle velocity is reduced in each stage, and the energy of the steam is effectively given up to the rotating parts. This type admits of lower speeds than the other forms of turbines. Fig. 8. shows the arrangement of nozzles, buckets, and stationary blades or guiding vanes for two stages. Governing is accomplished by shutting off the steam from some of the nozzles. A complete Curtis turbine of the vertical type, direct connected to a 5,000 K.W. three-phase alternating-current generator, is shown in Fig. 9.

The advantages claimed for this turbine are:

1. High steam economy at all loads
2. High steam economy with rapidly fluctuating loads.
3. Small floor space per K.W. capacity, reducing to a minimum the cost of real estate and buildings.
4. Uniform angular velocity.
5. Simplicity in operation and low expense for attendance.
6. Freedom from vibration.
7. Steam economy not appreciably impaired by wear or lack of adjustment in long service.
8. Adaptability to high steam pressure and high superheat without practical difficulty and with consequent improvement in economy.
9. Condensed water is kept entirely free from oil and can be returned to the boilers.

Many of these advantages apply equally well to the other types of turbines now on the market. All turbines are especially adapted to operation with superheated steam.

Engines should preferably be direct-connected as already stated, but this is not always feasible, and gearing, belt, or rope drives must be resorted to. Countershafts, belt or rope driven, arranged with pulleys and belts for the different generators, and with suitable clutches, are largely used in small stations. They consume considerable power and the bearings require attention.

Careful attention must be given to the lubrication of all running parts, and extensive oil systems are necessary in large plants.

In such systems a continuous circulation of oil over the bearings and through the engine cylinders is maintained by means of oil pumps. After passing through the bearings, the machine oil goes to a properly arranged oil-filter where it is cleaned and then pumped to the bearings again. A similar process is used in cyl-

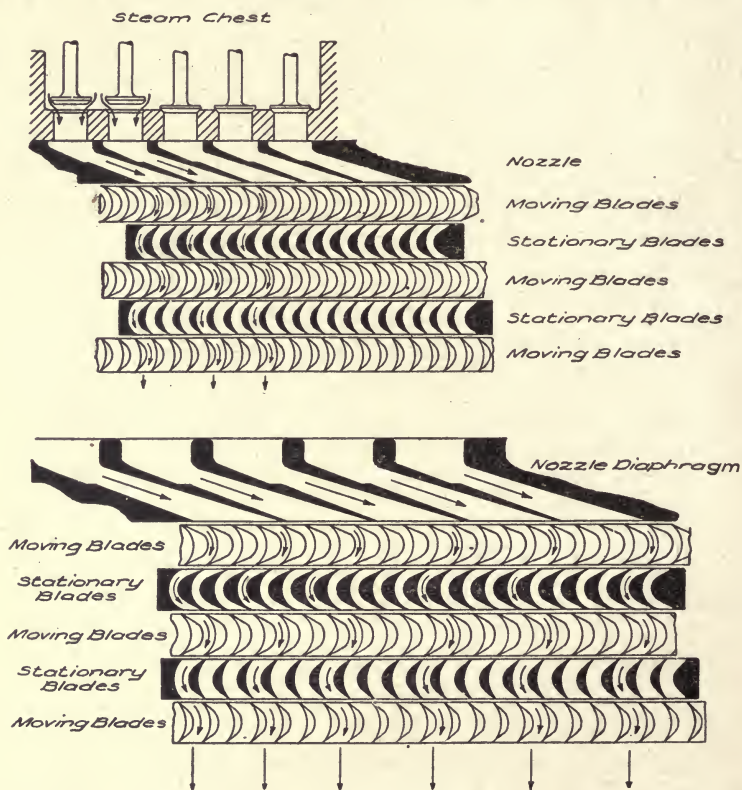
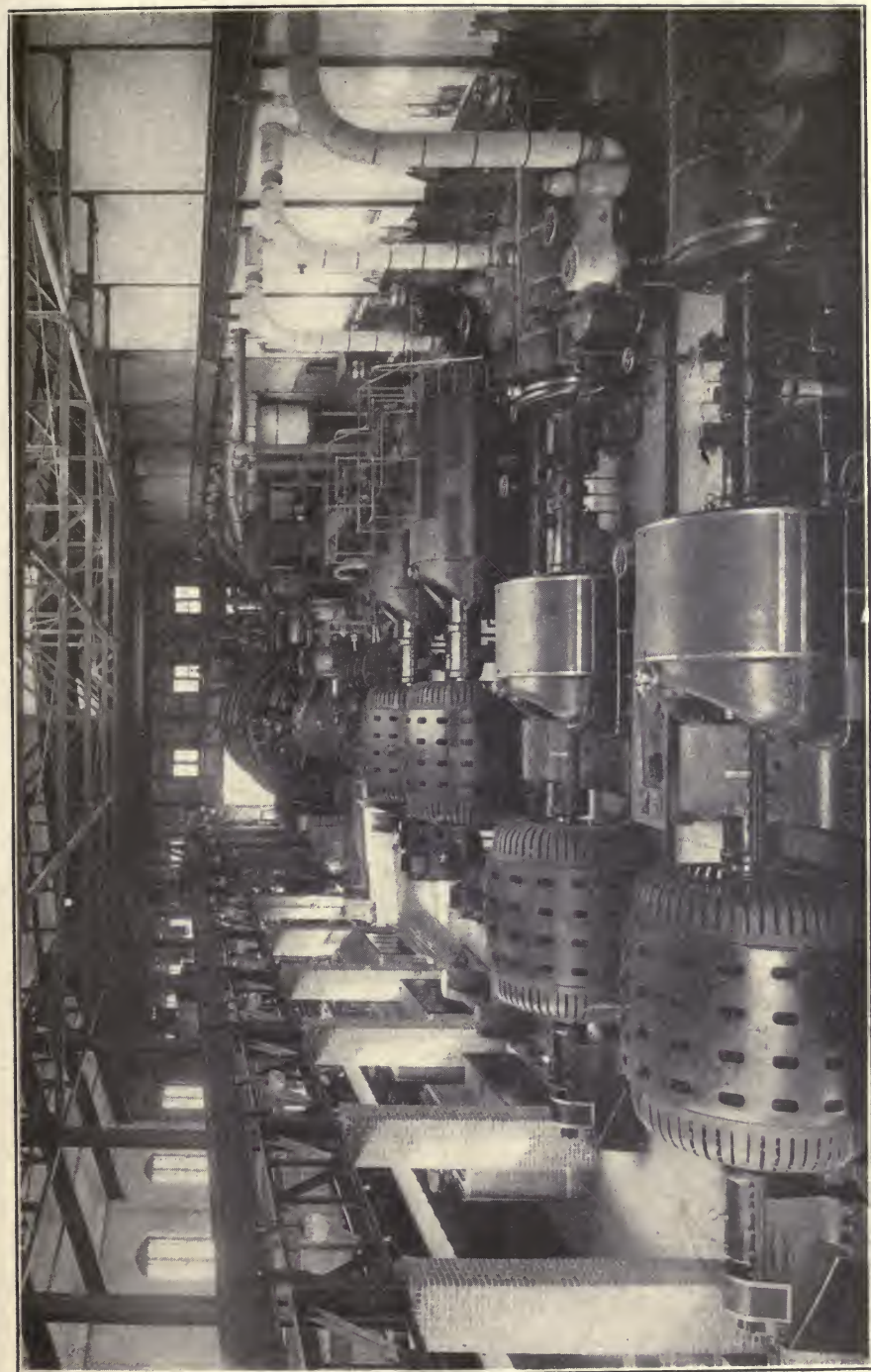

DIAGRAM OF NOZZLES AND BUCKETS IN CURTIS STEAM TURBINE.

Fig. 8.

inder lubrication, the oil being collected from the exhaust steam and only enough new oil is added to make up for the slight amount lost. The latter system is not installed as frequently as the continuous system for bearings. In the Curtis turbine, vertical type, the oil is forced in between the two plates, forming the step bearing, at such a pressure that a thin film of oil is constantly maintained between these plates. It may be arranged so that if, for any reason, this pressure fails, the steam will be cut off from the





GROUP OF WESTINGHOUSE-PARSONS TURBINE UNITS IN THE 16,000 H. P. PLANT OF THE PHILADELPHIA RAPID TRANSIT CO.  
The Westinghouse Machine Co.





turbine automatically. The bearings which support the shafts used with the generators at the Niagara Falls Power Companies' plants are generously flooded with oil and the turbines are arranged so as to remove a great deal of the weight of the rotating part from this bearing.

### HYDRAULIC PLANTS.

Because of the relative ease with which electrical energy may be transmitted long distances, it has become quite common to locate

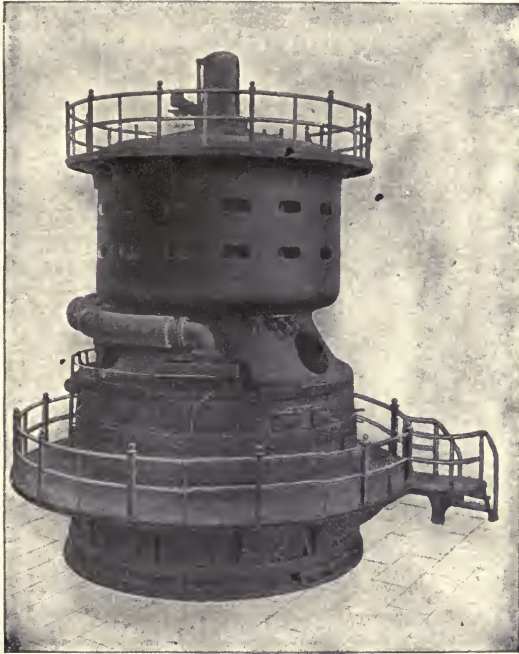

Fig. 9.

large power stations where there is abundant water power, and to transmit the energy thus generated to localities where it is needed. This type of plant has been developed to the greatest extent in the western part of the United States, where in some cases the transmission lines are very extensive. The power houses now completed, or in the course of erection at Niagara Falls, are examples of the enormous size such stations may assume.

Before deciding to utilize water power for driving the machinery in central stations, the following points should be noted:

1. The amount of water power available.
2. The possible demand for power.
3. Cost of developing this power as compared with cost of plants using other sources of power.
4. Cost of operation compared with other plants and extent of transmission lines.

Hydraulic plants are often much more expensive than steam plants, but the first cost is more than made up by the saving in operating expenses.

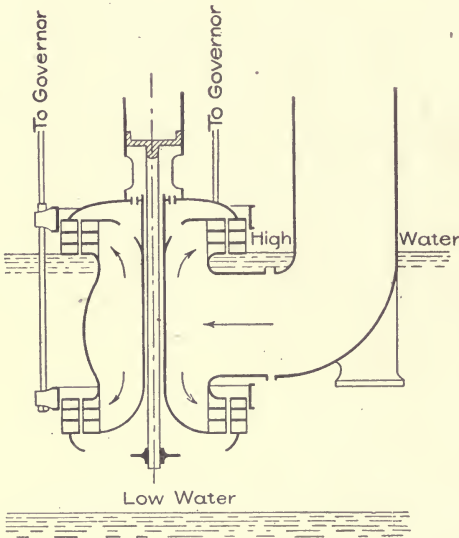
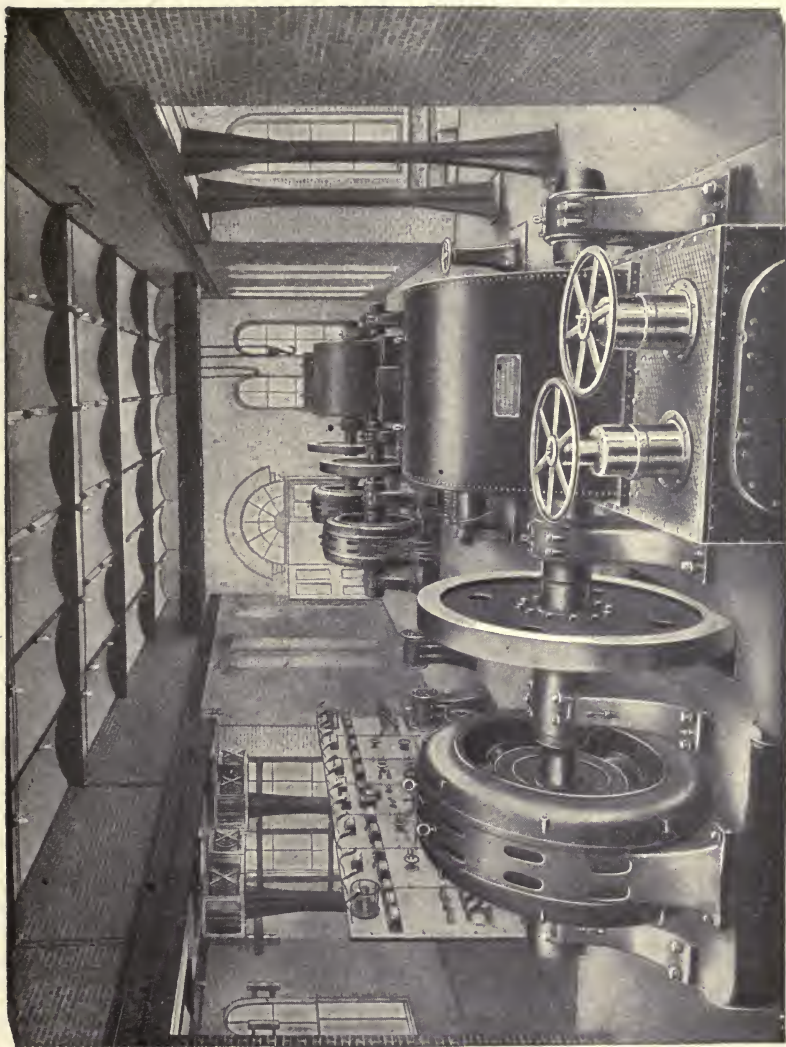

Fig. 10.

Methods for the development of water powers vary with the nature and amount of the water supply, and they may be studied best by considering plants which are in successful operation, each one of which has been a special problem in itself. A full description of such plants would be too extensive to be incorporated here, but they can be found in the various technical journals.

**Water Turbines** used for driving generators are of two general classes, reaction turbines and impulse turbines. The former may be subdivided into Parallel-flow, Outward-flow, and Inward-flow turbines. Parallel-flow turbines are suited for low falls, not exceeding 30 feet. Their efficiency is from 70 to 72%. Outward-flow and inward-flow turbines give an efficiency from 79 to 88%. Impulse turbines are suitable for very high falls and should be used from heads exceeding say 100 feet, though it is difficult to say at what head the reaction turbine would give place to the impulse wheel, as reaction turbines are giving good satisfaction on heads in the neighborhood of 200 feet, while impulse wheels are operated



INTERIOR OF PIKES PEAK POWER STATION.  
The Pelton Water Wheel Company.



with falls of but 80 feet. The Pelton wheel is one of the best known types of impulse wheels. An efficiency as high as 86% is

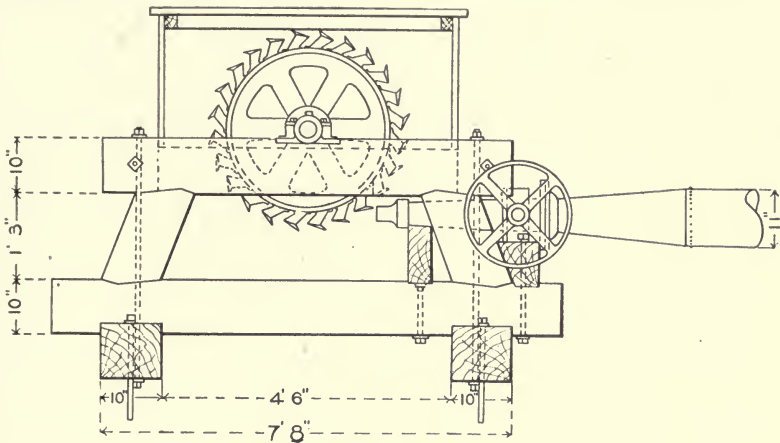

Fig. 11.

claimed for this type of wheel under favorable conditions. Fig. 10 shows a reaction wheel and Fig. 11 illustrates a Pelton wheel.

TABLE 7.  
Pressure of Water.

Feet Head.	Pressure Pounds per Square Inch.	Feet Head.	Pressure Pounds per Square Inch.	Feet Head.	Pressure Pounds per Square Inch.	Feet Head.	Pressure Pounds per Square Inch.
10	4.33	105	45.48	200	86.63	295	127.78
15	6.49	110	47.64	205	88.80	300	129.95
20	8.66	115	49.81	210	90.96	310	134.28
25	10.82	120	51.98	215	93.13	320	138.62
30	12.99	125	54.15	220	95.30	330	142.95
35	15.16	130	56.31	225	97.46	340	147.28
40	17.32	135	58.48	230	99.63	350	151.61
45	19.49	140	60.64	235	101.79	360	155.94
50	21.65	145	62.81	240	103.90	370	160.27
55	23.82	150	64.97	245	106.13	380	164.61
60	25.99	155	67.14	250	108.29	390	168.94
65	28.15	160	69.31	255	110.46	400	173.27
70	30.32	165	71.47	260	112.62	500	216.58
75	32.48	170	73.64	265	114.79	600	259.90
80	34.65	175	75.80	270	116.96	700	303.22
85	36.82	180	77.97	275	119.12	800	346.54
90	38.98	185	80.14	280	121.29	900	389.86
95	41.15	190	82.30	285	123.45	1000	433.18
100	43.31	195	84.47	290	125.62		

The fore bay leading to the flume should be made of such size that the velocity of water does not exceed  $1\frac{1}{2}$  feet per second, and



TABLE 8.  
Riveted Hydraulic Pipe.

Diam. of Pipe in inches.	Area of Pipe in sq. inches.	Thickness of Iron by wire gauge.	Head in Feet the Pipe will safely stand.	Cu. ft. Water Pipe will con- vey per min. at vel. 3 ft. per sec.	Weight per lineal ft. in lbs.
3	7	18	400	9	2
4	12	18	350	16	2 $\frac{1}{4}$
4	12	16	525	16	3
5	20	18	325	25	3 $\frac{1}{2}$
5	20	16	500	25	4 $\frac{1}{4}$
5	20	14	675	25	5
6	28	18	296	36	4 $\frac{1}{4}$
6	28	16	487	36	5 $\frac{3}{4}$
6	28	14	743	36	7 $\frac{1}{2}$
7	38	18	254	50	5 $\frac{1}{4}$
7	38	16	419	50	6 $\frac{3}{4}$
7	38	14	640	50	8 $\frac{1}{2}$
8	50	16	367	63	7 $\frac{1}{2}$
8	50	14	560	63	9 $\frac{1}{2}$
8	50	12	854	63	13
9	63	16	327	80	8 $\frac{1}{2}$
9	63	14	499	80	10 $\frac{3}{4}$
9	63	12	761	80	14 $\frac{1}{4}$
10	78	16	295	100	9 $\frac{1}{4}$
10	78	14	450	100	11 $\frac{3}{4}$
10	78	12	687	100	15 $\frac{3}{4}$
10	78	11	754	100	17 $\frac{1}{2}$
10	78	10	900	100	19 $\frac{1}{2}$
11	95	16	269	120	9 $\frac{3}{4}$
11	95	14	412	120	13
11	95	12	626	120	17 $\frac{1}{4}$
11	95	11	687	120	18 $\frac{3}{4}$
11	95	10	820	120	21
12	113	16	246	142	11 $\frac{1}{4}$
12	113	14	377	142	14
12	113	12	574	142	18 $\frac{1}{2}$
12	113	11	630	142	19 $\frac{3}{4}$
12	113	10	753	142	22 $\frac{3}{4}$
13	132	16	228	170	12
13	132	14	348	170	15
13	132	12	530	170	20
13	132	11	583	170	22
13	132	10	696	170	24 $\frac{1}{2}$
14	153	16	211	200	13
14	153	14	324	200	16
14	153	12	494	200	21 $\frac{1}{2}$
14	153	11	543	200	23 $\frac{1}{2}$
14	153	10	648	200	26
15	176	16	197	225	13 $\frac{3}{4}$
15	176	14	302	225	17
15	176	12	460	225	23
15	176	11	507	225	24 $\frac{1}{2}$
15	176	10	606	225	28
16	201	16	185	255	14 $\frac{1}{2}$
16	201	14	283	255	17 $\frac{1}{4}$
16	201	12	432	255	24 $\frac{1}{4}$
16	201	11	474	255	26 $\frac{1}{2}$



## Riveted Hydraulic Pipe. (Continued.)

Diam. of Pipe in inches.	Area of Pipe in sq. inches.	Thickness of Iron by wire gauge.	Head in Feet the Pipe will safely stand.	Cu. ft. Water Pipe will con- vey per min. at vel. 3 ft. per sec.	Weight per lineal ft. in lbs
16	201	10	567	255	29 $\frac{1}{2}$
18	254	16	165	320	16 $\frac{1}{2}$
18	254	14	252	320	20 $\frac{1}{2}$
18	254	12	385	320	27 $\frac{1}{4}$
18	254	11	424	320	30
18	254	10	505	320	34
20	314	16	148	400	18
20	314	14	227	400	22 $\frac{1}{2}$
20	314	12	346	400	30
20	314	11	380	400	32 $\frac{1}{2}$
20	314	10	456	400	36 $\frac{1}{2}$
22	380	16	135	480	20
22	380	14	206	480	24 $\frac{3}{4}$
22	380	12	316	480	32 $\frac{3}{4}$
22	380	11	347	480	35 $\frac{3}{4}$
22	380	10	415	480	40
24	452	14	188	570	27 $\frac{1}{4}$
24	452	12	290	570	35 $\frac{1}{2}$
24	452	11	318	570	39
24	452	10	379	570	43 $\frac{1}{2}$
24	452	8	466	570	53
26	530	14	175	670	29 $\frac{1}{4}$
26	530	12	267	670	38 $\frac{1}{2}$
26	530	11	294	670	42
26	530	10	352	670	37
26	530	8	432	670	57 $\frac{1}{4}$
28	615	14	102	775	31 $\frac{1}{4}$
28	615	12	247	775	41 $\frac{1}{4}$
28	615	11	278	775	45
28	615	10	327	775	50 $\frac{1}{4}$
28	615	8	400	775	61 $\frac{1}{4}$
30	706	12	231	890	44
30	706	11	254	890	48
30	706	10	304	890	54
30	706	8	375	890	65
30	706	7	425	890	74
36	1017	11	141	1300	58
36	1017	10	155	1300	67
36	1017	8	192	1300	78
36	1017	7	210	1300	88
40	1256	10	141	1600	71
40	1256	8	174	1600	86
40	1256	7	189	1600	97
40	1256	6	213	1600	108
40	1256	4	250	1600	126
42	1385	10	135	1760	74 $\frac{1}{2}$
42	1385	8	165	1760	91
42	1385	7	180	1760	102
42	1385	6	210	1760	114
42	1385	4	240	1760	133
42	1385	$\frac{3}{4}$	270	1760	137
42	1385	3	300	1760	145
42	1385	$\frac{5}{8}$	321	1760	177
42	1385	$\frac{3}{8}$	363	1760	216

it should be free from abrupt turns. The same applies to the tail race. The velocity of water in wooden flumes should not exceed 7 to 8 feet per second. Riveted steel pipe is used for the penstocks and for carrying water from considerable distances under high heads. In some locations it is buried, in others it is simply placed on the ground. Wooden-stave pipe is used to a large extent when the heads do not much exceed 200 feet. Table 7 gives the pressure of water at different heads, while Table 8 gives considerable data relating to riveted-steel hydraulic pipe.

**Governors** are required to keep the speed constant under change of load and change of head. Various governors are manufactured which give excellent satisfaction.

TABLE 9.

**Horse Power per cubic foot of water per minute for different heads.**

Heads in Feet.	Horse Power.	Heads in Feet.	Horse Power	Heads in Feet.	Horse Power.	Heads in Feet.	Horse Power.
1	.0016098	170	.273666	330	.531234	490	.788802
20	.032196	180	.289764	340	.547332	500	.804900
30	.048294	190	.305862	350	.563430	520	.837096
40	.064392	200	.321960	360	.579528	540	.869292
50	.080490	210	.338058	370	.595626	560	.901488
60	.096588	220	.354156	380	.611724	580	.933684
70	.112686	230	.370254	390	.627822	600	.965880
80	.128784	240	.386352	400	.643920	650	1.046370
90	.144892	250	.402450	410	.660018	700	1.126860
100	.160980	260	.418548	420	.676116	750	1.207350
110	.177078	270	.434646	430	.692214	800	1.287840
120	.193176	280	.450744	440	.708312	900	1.448820
130	.209274	290	.466842	450	.724410	1000	1.609800
140	.225372	300	.482940	460	.740508	1100	1.770780
150	.241470	310	.499038	470	.756606		
160	.257568	320	.515136	480	.772704		

### GAS ENGINES.

There are at present, in the United States, several successful electrical installations using gas engines as prime movers, while they have been operated abroad for a greater length of time. The advantages for gas engines are given as follows:

1. Minimum fuel and heat consumption.
2. Light-load efficiency is higher than for the steam engines.
3. Low cost of operation and maintenance.

4. Simplification of equipment and small number of auxiliaries.
5. No heat lost due to radiation when engines are idle.
6. Quick starting.
7. Extensions may be easily made.
8. High pressures are limited to the engine cylinders.

Fig. 12 shows the efficiency and amount of gas consumed by a 550 H.P. engine, Pittsburg natural gas being used.

The only auxiliaries needed are the igniter generators and the air compressors, with a pump for the jacket water in some cases. These may be driven by a motor or by a separate gas engine. The jacket water may be utilized for heating purposes in many plants. Cooling towers may be installed where water is scarce.

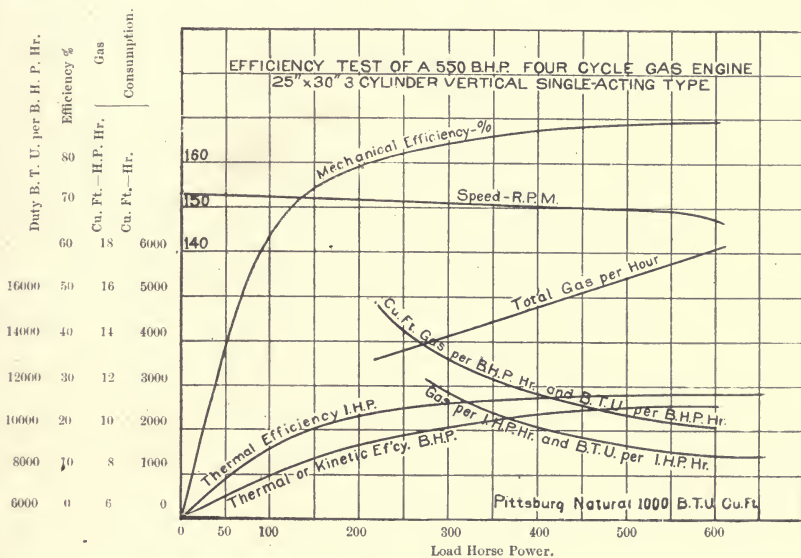

Fig. 12.

Parallel operation of alternators when direct-driven by gas engines has been successful, a spring coupling being used between the engines and generators in some cases to absorb the variation in angular velocity.

The fact that no losses occur, due to heat radiation when the machines are not running, and the lack of losses in piping, add greatly to the plant efficiency. If producer gas or blast furnace gas is used, a larger engine must be installed, to give the same power, than when natural or ordinary coal gas is used. Electric

stations are often combined with gas works, and gas engines can be installed in such stations to particular advantage in many cases.

## THE ELECTRICAL PLANT.

### GENERATORS.

The first thing to be considered in the electrical plant is the generators, after which the auxiliary apparatus in the way of exciters, controlling switches, safety devices, etc., will be taken up. A general rule which, by the way, applies to almost all machinery for power stations is to select apparatus which is considered as "standard" by the manufacturing companies. This rule should be followed for two reasons. First, reliable companies employ men who may be considered as experts in the design of their machines, and their best designs are the ones which are standardized. Second, standard apparatus is from 15 to 25% cheaper than semi-standard or special work, owing to larger production, and it can be furnished on much shorter notice. Again, repair parts are more cheaply and readily obtained.

Specifications should call for performance, and details should be left, to a very large extent, to the manufacturers. Following are some of the matters which may be incorporated in the specifications for generators:

1. Type and general characteristics.
2. Capacity and overload with heating limits.
3. Commercial efficiency at various loads.
4. Excitation.
5. Speed and regulation.
6. Floor space.
7. Mechanical features.

As to the type of machine, this will be determined by the system selected. They may be direct-current, alternating-current, single or polyphase, or as in some plants now in operation, they may be double-current generators. The voltage, compounding, frequency, etc., should be stated. Direct-current machines are seldom wound for a voltage above 600, but alternating-current generators may be purchased which will give as high as 15,000 volts at the terminals. As a rule it is well not to use an extremely high voltage for the generators themselves, but to use step-up transformers in case a very high line voltage is necessary. Up to about 7,000 volts generators may be safely used directly on the line.

Above this local conditions will decide whether to connect the machine directly to the line or to step up the voltage. Machines wound for high potential are more expensive for the same capacity and efficiency, but the cost of step-up transformers and the losses in the same are saved by using such machines, so that there is a slight gain in efficiency which may be utilized in better regulation of the system, or in lighter construction of the line. On the other hand, lightning troubles are liable to be aggravated when transformers are not used, as the transformers act as additional protection to the machines, and if the transformers are injured they may be more readily repaired or replaced.

The following voltages are considered standard:

Direct-current generators 125, 250, 550-600.

Alternating-current systems, high pressure, 2,200, 6,000, 10,000, 15,000, 20,000, 30,000, 40,000, 60,000.

The generators, with transformers when used, should be capable of giving a no-load voltage 10% in excess of these figures. 25 and 60 cycles are considered as standard frequencies, the former being more desirable for railway work and the latter for lighting purposes.

The size of machines to be chosen has been briefly considered. Alternators are rated for non-inductive load or a power factor of unity. Aside from the overload capacity to be counted upon as reserve, the Standardization Report of the American Institute of Electrical Engineers recommends the following for the heating limits and overload capacity of generators:

Maximum values of temperature elevation,

Field and armature, by resistance, 50° C.

Commutator and collector rings and brushes, by thermometer, 55° C.

Bearings and other parts of machine, by thermometer, 40° C.

Overload capacity should be 25% for two hours, with a temperature rise not to exceed 15° above full load values, the machine to be at constant temperature reached under normal load, before the overload is applied. A momentary overload of 50% should be permissible without excessive sparking or injury. Some companies recommend an overload capacity of 50% for two hours when the machines are to be used for railway purposes.



As a rule, generators should have a high efficiency over a considerable range of load, although the nature of the load will have much to do with this. It is always desirable that maximum efficiency be as high as is compatible with economic investment.

Table 10 gives reasonable efficiencies which may be expected for generating apparatus. In order to arrive at what may be considered the best maximum efficiency to be chosen, the cost of power generation must be known, or estimated, and the fixed charges on capital invested must also be a known quantity. From the cost of power, the saving on each per cent increase in efficiency can be determined, and this should be compared with the charges on the additional investment necessary to secure this increased efficiency. A certain point will be found where the sum of the two will be a minimum.

If a generator is to be run for a considerable time at light loads, one with low "no-load" losses should be chosen. These losses are not rigidly fixed but they vary slightly with change of load. It is the same question of "all-day efficiency" which is treated, in the case of transformers, in "Power Transmission". Under no-load losses may be considered, in shunt-wound generators, friction losses, core losses, and shunt-field losses. I<sup>2</sup>R losses in the series field, in the armature, and in the brushes, vary as the square of the load.

Table 10.

Average Maximum Efficiencies.

K.W.	Per Cent
5	85
10	88
25	90
50	92
150	93
200	94
500	95
1000	96

Dynamos, if for direct current, may be self-excited, shunt- or compound-wound, or separately excited. Separate excitation is not recommended for these machines. Alternators require separate excitation, though they may be compounded by using a portion of the armature current when rectified by a commutator. Automatic regulation of voltage is always desirable, hence the general use of

compound-wound machines for direct currents. Many alternators using rectified currents in series fields for keeping the voltage nearly constant are in service in small plants as well as several of the so-called "compensated" alternators, arranged with special devices which maintain the same compounding with different power factors. The latter machine gives good satisfaction if properly cared for, but an automatic regulator, governed by the generator voltage and current, which acts directly on the exciter field, is taking its place. The capacity of the exciters must be such that they will furnish sufficient excitation to maintain normal voltage at the terminals of the generators when running at 50% overload. Table 11 gives the proper capacity of exciter for the generator listed.

**TABLE 11.**  
**Exciters for Single-Phase Alternating-Current Generators.**  
60 Cycles.

Alternator Classification.			Exciter Classification.		
Poles.	K.W.	Speed.	Poles.	K.W.	Speed.
8	60	900	2	1.5	1900
8	90	900	2	1.5	1900
8	120	900	2	1.5	1900
12	180	600	2	2.5	1900
16	300	450	2	4.5	1800

If direct-connected, the speeds of the generators will be determined by the prime mover selected. If belt-driven, small machines may be run at a high speed, as high-speed machines are cheaper than slow- or moderate-speed generators. In large sizes, this saving is not so great.

When shunt-wound dynamos are used, the inherent regulation should not exceed 2 to 3% for large machines. For alternators, this is much greater and depends on the power factor of the load. A fair value for the regulation of alternators on non-inductive load is 10 per cent.

**Exciters** may be either direct-connected or belted to the shaft of the machine which they excite, or they may be separately

driven. They are usually compound-wound and furnish current at 125 or 250 volts. Separately driven exciters are preferred for most plants as they furnish a more flexible system, and any drop in the speed of the generator does not affect the exciter voltage. Ample reserve capacity of exciters should be installed, and in some cases storage batteries, used in conjunction with exciters, are recommended in order to insure reliability of service.

Motor-generator sets, boosters, frequency changers, and other rotating devices come under the head of special apparatus and are governed by the same general rules as generators.

**Transformers** for stepping the voltage from that generated by the machine up to the desired line voltage, or *vice versa*, at the substation, may be of three general types, according to the method of cooling. Large transformers require artificial means of cooling, if they are not to be too bulky and expensive. They may be air-cooled, oil-cooled, or water-cooled.

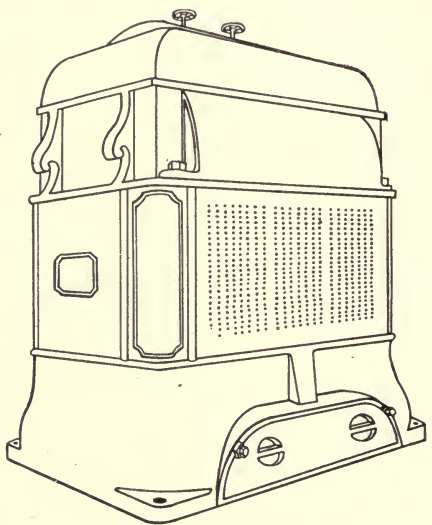

Fig. 13.

*Air-cooled transformers* are usually mounted over an air-tight pit fitted with one or more motor-driven blowers which feed into the pit. The transformer coils are subdivided so that no part of the winding is at a great distance from air and the iron is provided with ducts. Separate dampers control the amount of air which passes between the coils or through the iron. Such transformers give good satisfaction for voltages up to 20,000 or higher, and can be built for any capacity. Care must be taken to see that there is no liability of the air supply failing, as the capacity of the transformers is greatly reduced when not supplied with air. Fig. 13 shows a three-phase air-blast transformer.

*Oil-cooled transformers* have their cores and windings placed in a large tank filled with oil. The oil serves to conduct the heat to the case, and the case is usually either made of corrugated sheet metal or of cast iron containing deep grooves, so as to increase the radiating surface. These transformers do not require such heavy

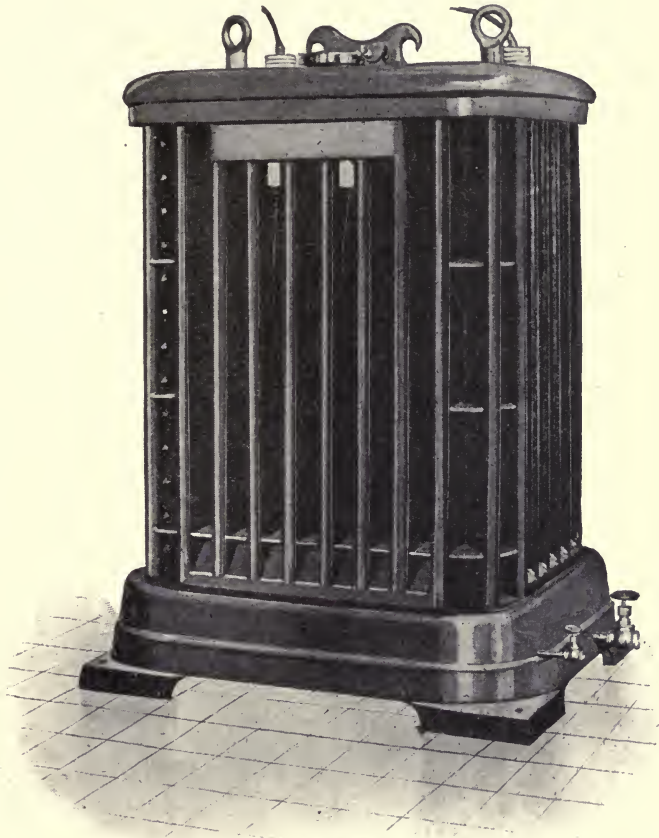

Fig. 14. 150 K.W. Self-Cooled Oil Transformer.

insulation on the outside of the coils as air-blast machines because the oil serves this purpose. Simple oil-cooled transformers are seldom built for capacities exceeding 250 K.W. as they become too bulky, but they are employed for the highest voltages now in use. Fig. 14 shows a transformer of this type.

*Water-cooled transformers.* When large transformers for high voltages are required, the water-cooled type is usually selected. This type is similar to an oil-cooled transformer, but with water

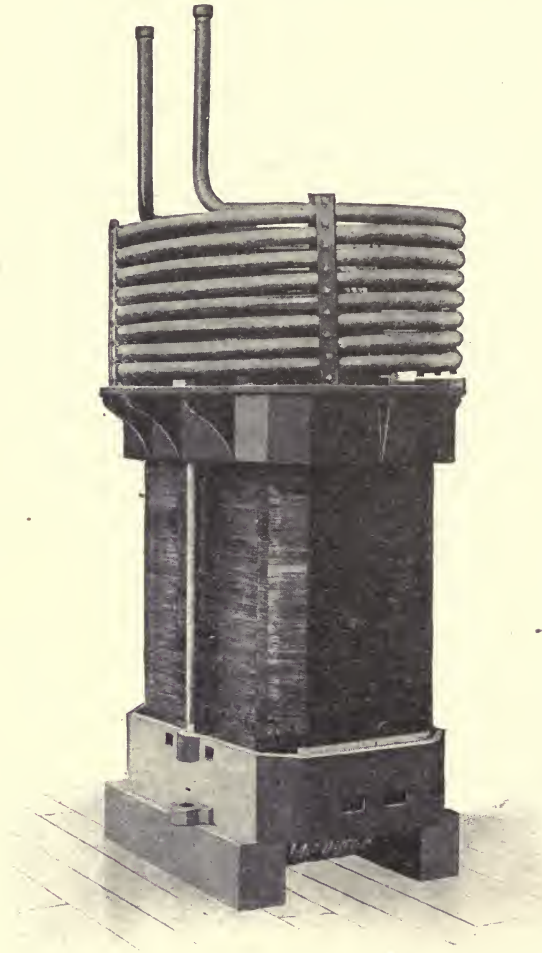

Fig. 15. Water-Cooled Transformer.

tubes arranged in coils in the top. Cold water passes through these tubes and aids in removing heat from the oil. Some types have the low-tension windings made up of tubes through which the water circulates. Water-cooled transformers must not have



the supply of cooling water shut off for any length of time when under normal load or they will overheat. Fig. 15 shows a water-cooled transformer.

For connections of transformers, see "Power Transmission".



Fig. 15. 400 K.W. Water Cooled Oil Transformer.

One or more spare transformers should always be on hand and they should be arranged so that they can be put into service on very short notice.

Three-phase transformers allow a considerable saving in floor space, as can be seen by referring to Fig. 16; they are cheaper than three separate transformers which make up the same capacity, but they are not as flexible as a single-phase transformer and one

complete unit must be held for a reserve or "spare" transformer.

**Storage Batteries.** The use of storage batteries for central stations and substations is clearly outlined in "Storage Batteries". The chief points of advantage may be enumerated as follows:

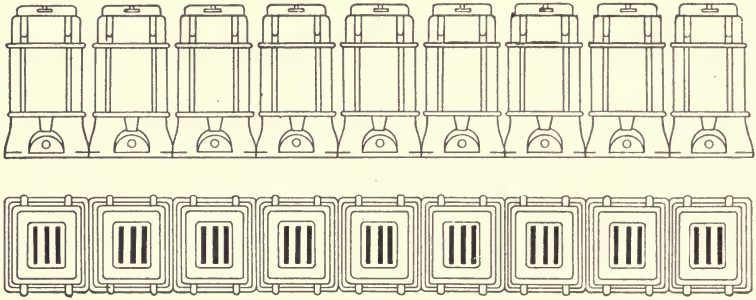

Single-Phase Air-Blast Transformers. Total Capacity 3,000 K.W.

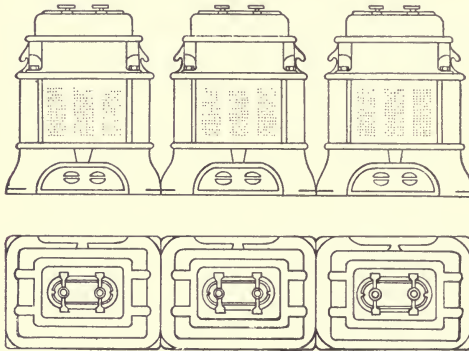

Three-Phase Air-Blast Transformers. Total Capacity 3,000 K.W.

Fig. 16.

1. Reduction in fuel consumption due to the generating machinery being run at its greatest economy.
2. Better voltage regulation.
3. Increased reserve capacity and less liability to interruption of service.

The main disadvantage is the high cost.

**Switchboards.** The switchboard is the most vital part of the whole system of supply, and should receive consideration as such. Its objects are: to collect the energy as supplied by the generators and direct it to the desired feeders, either overhead or

under ground; furnish a support for the various measuring instruments connected in service, as well as the safety devices for the protection of the generating apparatus; and control the pressure of the supply. Some of the essential features of all switchboards are:

1. The apparatus and supports must be fire-proof.
2. The conducting parts must not overheat.
3. Parts must be easily accessible.
4. Live parts except for low potentials must not be placed on the front of the operating panels.
5. The arrangement of circuits must be symmetrical and as simple as it is convenient to make them.
6. Apparatus must be arranged so that it is impossible to make a wrong connection that would lead to serious results.
7. It should be arranged so that extensions may be readily made.

There are two general types—in the first, all of the switching and indicating apparatus is mounted directly on panels, and in the second, the current-carrying parts are at some distance from the panels, the switches being controlled by long connecting rods; operated electrically or by means of compressed air. The first may again be divided into direct-current and alternating-current switchboards. It is from the first class of apparatus that the switchboard gets its name and the term is still applied, even when the board proper forms the smallest part of the equipment. Switchboards have been standardized to the extent that standard generator, exciter, feeder, and motor panels may be purchased for certain classes of work, but the vast majority of them are made up as semi-standard or special.

The leads which carry the current from the machines to the switches should be put in with very careful consideration. Their size should be such that they will not heat excessively when carrying the rated overload of the machine, and they should preferably be placed in fire-proof ducts, although low-potential leads do not always require this construction. Curves showing sizes for lead-covered cables for different currents are given in "Power Transmission". Table 12 gives standard sizes of wires and cables together with the thickness of insulation necessary for different voltages. Cables should be kept separate as far as possible so that if a fault does occur on one cable, neighboring conductors

will not be injured. For lamp and instrument wiring, such as leads to potential and current transformers, the following sizes of wire are recommended:

- No. 16 or No. 14, wiring to lamp sockets.
- No. 12 wire,  $\frac{3}{4}$ " rubber insulation, all other small wiring under 600 volts potential.
- No. 12,  $\frac{3}{8}$ " rubber insulation for primaries of potential transformers from 600 to 3,500 volts.
- No. 8,  $\frac{5}{8}$ " rubber insulation for primaries of potential transformers up to 6,600 volts.
- No. 8,  $\frac{3}{2}$ " rubber insulation for primaries of potential transformers up to 10,000 volts.
- No. 4,  $\frac{3}{4}$ " rubber insulation for primaries of potential transformers up to 15,000 volts.
- No. 4,  $\frac{3}{4}$ " rubber insulation for primaries of potential transformers up to 20,000 volts.
- No. 4,  $\frac{1}{2}$ " rubber insulation for primaries of potential transformers up to 25,000 volts.

Where high-tension cables leave their metallic shields they are liable to puncture, so that the sheath should be flared out at this point and the insulation increased by the addition of compound. Fig. 17 shows such cable bells, as they are called, as recommended by the General Electric Company.

Central-station switchboards are usually constructed of panels about 90 inches high, from 16 inches to 36 inches wide, and  $1\frac{1}{2}$  inches to 2 inches thick. Such panels are made of Blue Vermont, Pink Tennessee, or White Italian marble, or of black enameled slate. Slate is not recommended for voltages exceeding 1,100. The panels are in two parts, the sub-base being from 24 to 28 inches high. They are polished on the front and the edges are beveled. Angle and tee bars, together with foot irons and tie rods, form the supports for such panels, and on these panels are mounted the instruments, main switches, or controlling apparatus for the main switches, as the case may be, together with relays and hand wheels for rheostats and regulators. Small panels are sometimes mounted on pipe supports.

The usual arrangement of the panels is to have a separate panel for each generator, exciter, and feeder, together with what is known as a station or total-output panel. In order to facilitate extensions and simplify connections, the feeder panels are located

at one end of the board and the generator panels are placed at the other end, and the total-output panel between the two. The main bus bars extend throughout the length of the generator and feeder panels, and the desired connections are readily made. The instruments required are very numerous and a brief description only of a few of the more important can be given here.

TABLE 12.  
Standard Wire and Cable.

Wire (Solid).

Area. Circular Mils.	Diam. Inches. Bare.	Terminal Drillings.	Amps. Con. Curr. Capacity.	Thickness of Rubber Insulation.						Gauge. B. & S	
				Volts 600	3500	6000	10000	15000	20000		25000
				Special Insulation.							
2,582	.051	No. 30 Dr.	4								16
4,106	.064	30 "	6	$\frac{3}{64}$							14
6,530	.081	30 "	10	$\frac{3}{64}$	$\frac{3}{32}$						12
16,510	.128	18 "	25	$\frac{3}{64}$	$\frac{3}{32}$	$\frac{5}{32}$					8
26,251	.162	5 "	40	$\frac{1}{16}$	$\frac{3}{32}$	$\frac{5}{32}$	$\frac{7}{32}$				6
41,743	.204	4 "	60	$\frac{1}{16}$	$\frac{3}{32}$	$\frac{5}{32}$	$\frac{7}{32}$	$\frac{21}{64}$	$\frac{14}{32}$	$\frac{17}{32}$	4
66,373	.257	4 "	90	$\frac{1}{16}$	$\frac{3}{32}$	$\frac{5}{32}$	$\frac{7}{32}$	$\frac{21}{64}$	$\frac{14}{32}$	$\frac{17}{32}$	2
83,695	.289	4 "	110	$\frac{5}{64}$	$\frac{3}{32}$	$\frac{5}{32}$	$\frac{7}{32}$	$\frac{21}{64}$	$\frac{14}{32}$	$\frac{17}{32}$	1
105,593	.325	4 "	130	$\frac{5}{64}$	$\frac{3}{32}$	$\frac{5}{32}$	$\frac{7}{32}$	$\frac{21}{64}$	$\frac{14}{32}$	$\frac{17}{32}$	0
133,079	.365	4 "	170	$\frac{5}{64}$	$\frac{3}{32}$	$\frac{5}{32}$	$\frac{7}{32}$	$\frac{21}{64}$	$\frac{14}{32}$	$\frac{17}{32}$	00
167,805	.410	4 "	205	$\frac{5}{64}$	$\frac{3}{32}$	$\frac{5}{32}$	$\frac{7}{32}$	$\frac{21}{64}$	$\frac{14}{32}$	$\frac{17}{32}$	000
211,600	.460	4 "	250	$\frac{5}{64}$	$\frac{3}{32}$	$\frac{5}{32}$	$\frac{7}{32}$	$\frac{21}{64}$	$\frac{14}{32}$	$\frac{17}{32}$	0000

Cable.

(Stranded.)

Circular Mils.	Diameter. Inches. Bare.	Terminal Drilling	Con. Curr. Capacity. Amps.	Thickness of Rubber Insulation. (For 6000 V. only.)
250,000	.568	$\frac{5}{16}$ "	290	$\frac{3}{32}$
300,000	.637	$\frac{3}{8}$ "	340	$\frac{3}{32}$
350,000	.680	$\frac{3}{8}$ "	380	$\frac{3}{32}$
400,000	.735	$\frac{1}{2}$ "	420	$\frac{3}{32}$
500,000	.820	$\frac{1}{2}$ "	500	$\frac{3}{32}$
600,000	.900	1"	575	$\frac{7}{64}$
800,000	1.037	1 $\frac{1}{8}$ "	710	$\frac{7}{64}$
1,000,000	1.157	1 $\frac{1}{4}$ "	830	$\frac{7}{64}$
1,500,000	1.412	1 $\frac{3}{4}$ "	1100	$\frac{1}{4}$
2,000,000	1.65	1 $\frac{3}{4}$ "	1350	$\frac{1}{4}$



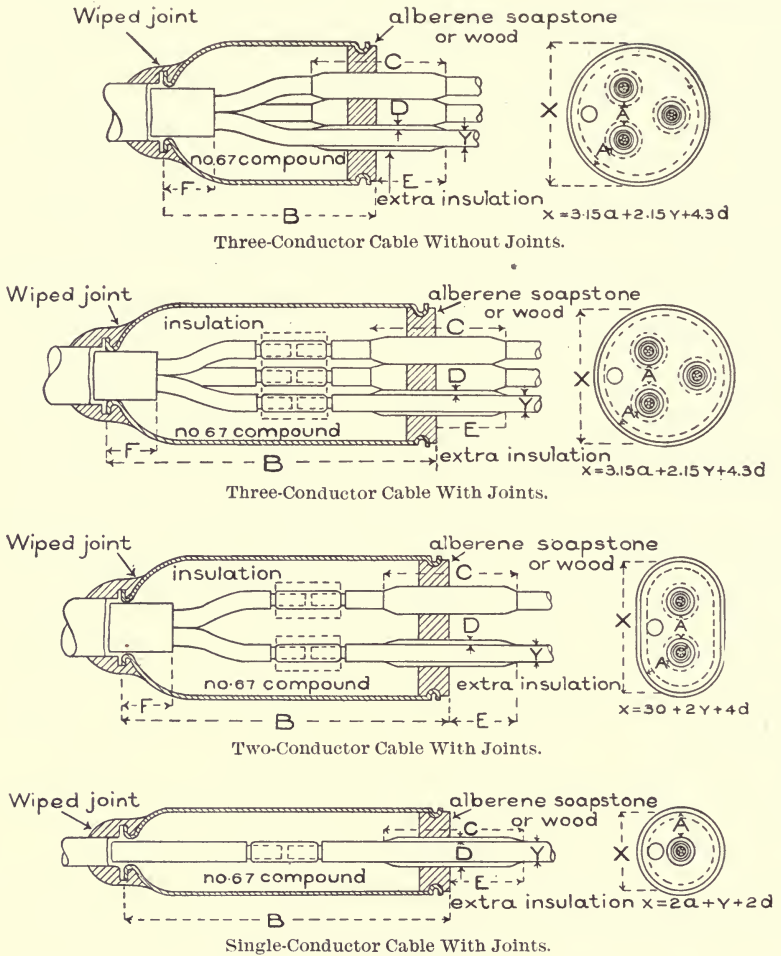

VOLTS.	A	B	C	D	E	F
6600	1	12	5	$\frac{1}{8}$	$2\frac{1}{2}$	1
13200	$1\frac{1}{2}$	15	8	$\frac{1}{4}$	4	2
26400	2	19	14	$\frac{1}{2}$	7	4

$\frac{1}{4}$ -inch Lead or  $\frac{1}{16}$ -inch Brass Bells.

Fig. 17.

For direct current generator panels there are usually required:

- 1 Main switch.
- 1 Field switch.
- 1 Ammeter.
- 1 Voltmeter.
- 1 Field rheostat with controlling mechanism.
- 1 Circuit breaker
- Bus bars and various connections.

These may be arranged in any suitable order, the circuit breaker being preferably located at the top so that any arcing which may occur will not injure other instruments. Fig. 18 gives a wiring diagram of such a panel.

The main switch may be single or double throw, depending on whether one or two sets of bus bars are used. It may be triple pole as shown in Fig. 18, in which the middle bar serves as the equalizing switch, or the equalizing switch may be mounted on a pedestal near the machine, in which case the generator switch would be double-pole.

The field switch for large machines should be double-pole fitted with carbon breaks and arranged with a discharge resistance consisting of a resistance which is thrown across the terminals of the field just before the main circuit is opened. One voltmeter located on a swinging bracket at the end of the panel, and arranged so that it can be thrown across any machine or across the bus bars by means of a dial switch, is sometimes used, but it is preferable to have a separate meter for each generator.

Small rheostats are mounted on the back of the panel, but large ones are chain operated and preferably located below the floor, the controlling hand wheel being mounted on the panel.

The circuit breaker may be of the carbon break or the magnetic blow-out type. Fig. 19 shows circuit breakers of both

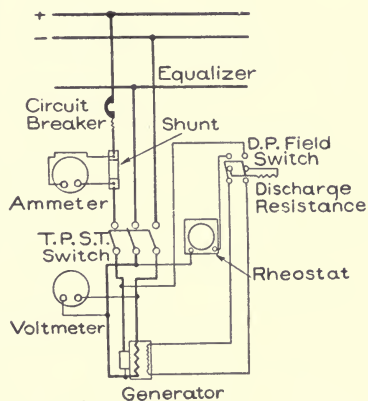

Fig. 18.

types. Lighting panels for low potentials are often fitted with fuses instead of circuit breakers, in which case they may be open fuses on the back of the panel or enclosed fuses on either the front or back of the panel.

**Direct-Current feeder panels** contain:

1 Ammeter.

1 Circuit Breaker.

1 or more main switches, single-pole, and single- or double-throw.

1 recording wattmeter, not always used

Apparatus for controlling regulators when such are used.

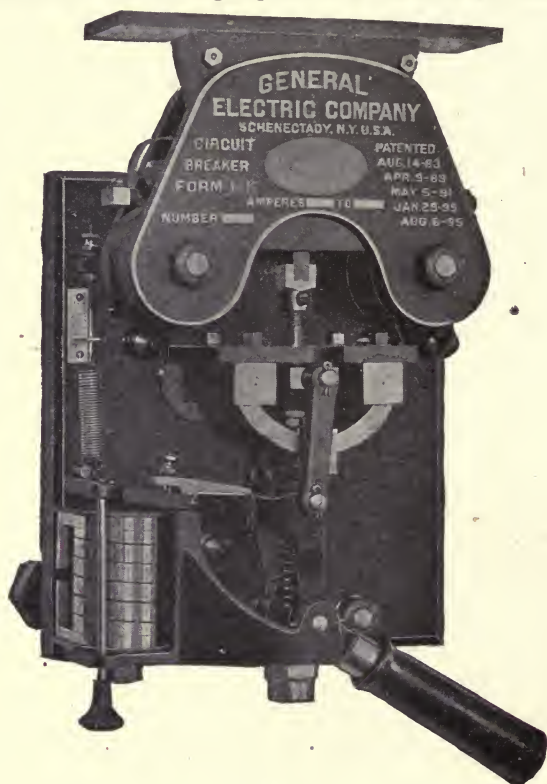
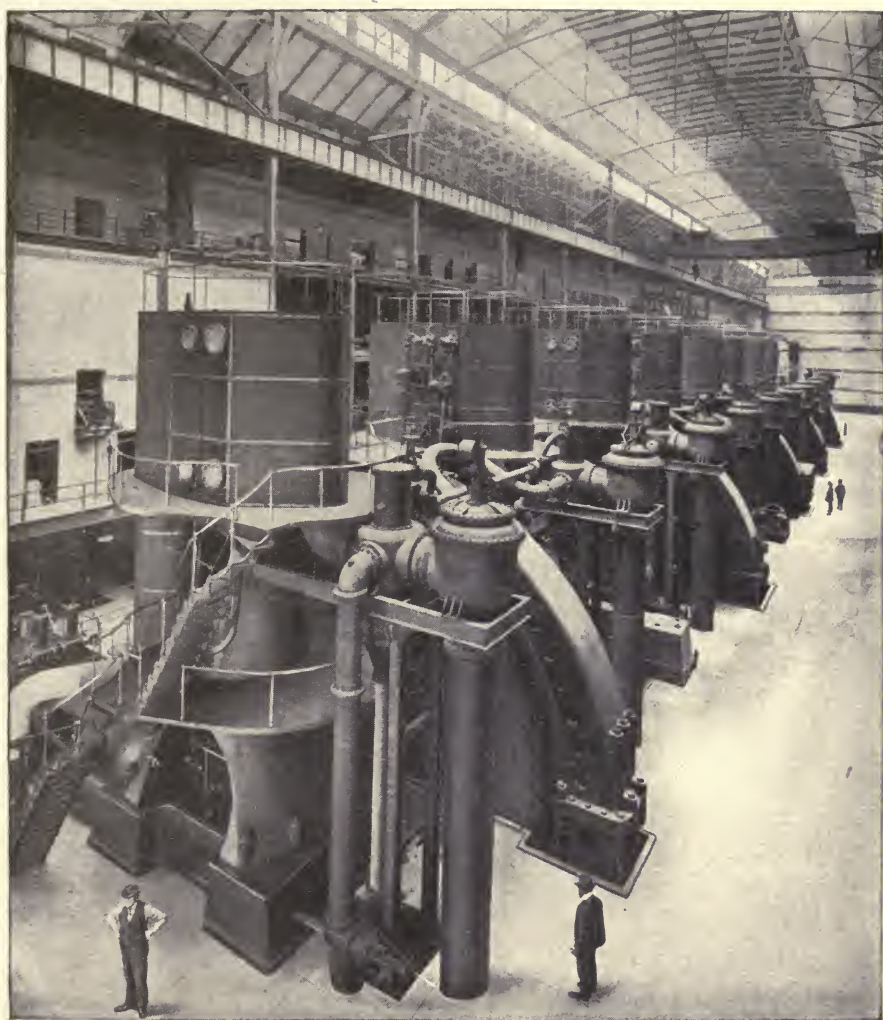

Fig. 19.

One voltmeter usually serves for several feeder panels, such a meter being mounted above the panels or on a swinging bracket at the end. Switches should preferably be of the quick-break type. Fig. 20 shows some standard railway feeder panels.

**Exciter Panels** are nothing more than generator panels on a small scale.



**POWER HOUSE OF NEW YORK SUBWAY.**

Showing Five of the Nine 12,000 Horse-Power Allis-Chalmers Engines.





**Total Output Panels** contain instruments recording the total power delivered by the plant to the switchboard. Alternating-current panels for potentials up to 1,100 volts follow the same general construction. Synchronizing devices are necessary on the generator panels, and additional ammeters are used for polyphase boards. Sometimes the exciter and generator panels are combined

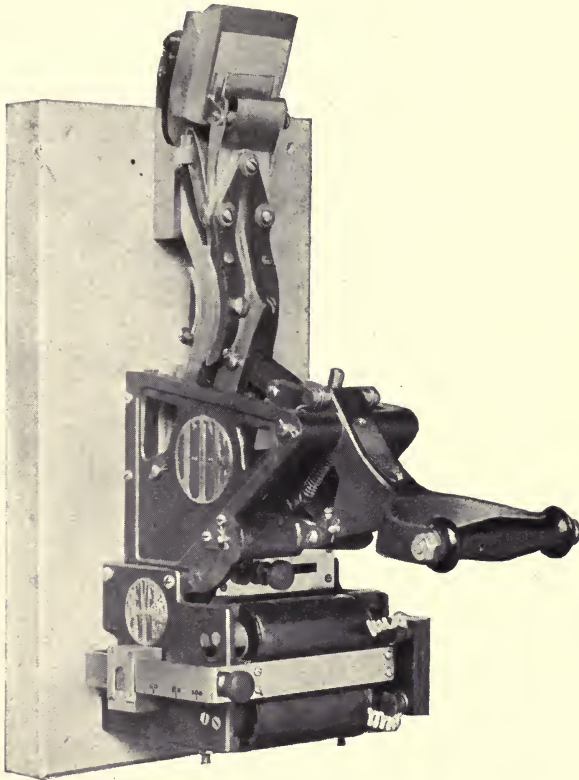

Fig. 19.

in one. Fig. 21 shows such a combination. The same construction is sometimes used for voltages up to 2,500, though it is not usually recommended. The paralleling of alternators is treated in "Management of Dynamo Electric Machinery".

For the higher voltages, the measuring instruments are no longer connected directly in the circuit, and the main switch is not mounted directly on the panel. Current and potential trans-

formers are used for connecting to the indicating voltmeters and ammeters, and the recording wattmeters and potential transformers are used for the synchronizing device. These transformers are mounted at some distance from the panel, while the switches may

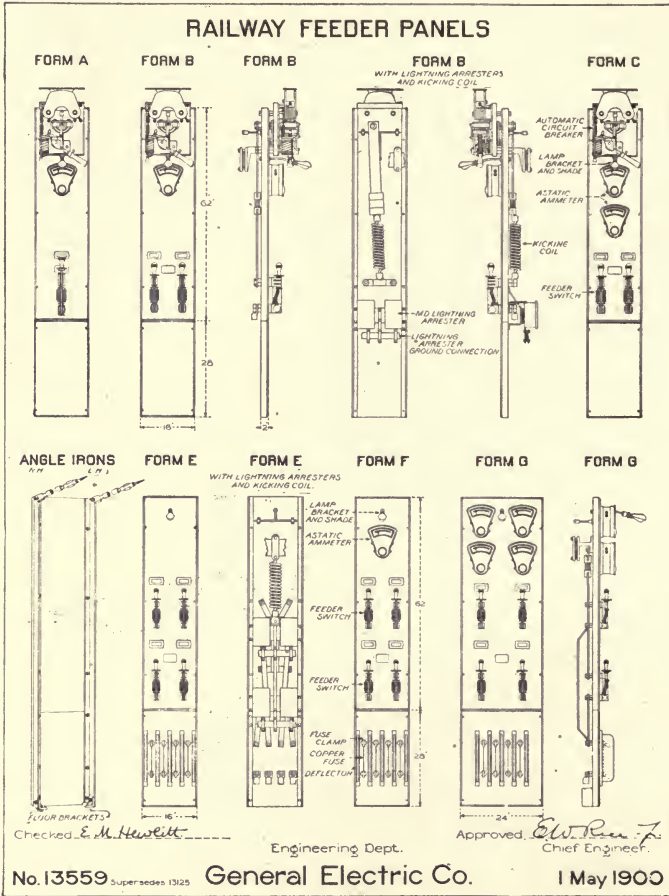

Fig. 20.

be located near the panel and operated by a system of levers, or they may be located at considerable distance and operated by electricity or by compressed air.

**Oil Switches** are recommended for all high potential work for the following reasons: By their use it is possible to open circuits of higher potential and carrying greater currents than with

any other type of switch. They may be made quite compact. They may readily be made automatic and thus serve as circuit breakers for the protection of machines and circuits when overloaded.

**SWITCHBOARD PANEL FOR  
ONE THREE-PHASE ALTERNATING CURRENT GENERATOR  
TO 2500 VOLTS**

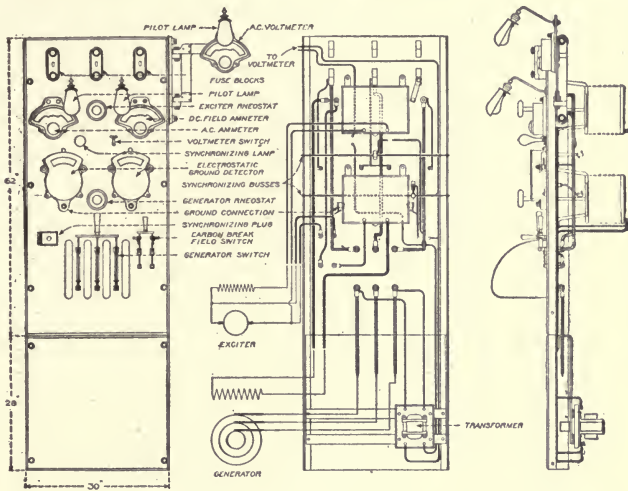

CLASSIFICATION						
Type	Volts	Amperes	Form	Switch	Field Ammeter	Synchronizing Device
A T G	2500	130	* A 1	S.T.	with	with
A T G	2500	130	A 2	S.T.	with	without
A T G	2500	130	A 3	S.T.	without	with
A T G	2500	130	A 4	S.T.	without	without
A T G	2500	130	A 5	D.T.	with	without
A T G	2500	130	A 6	D.T.	without	without

Transformer is calibrated with Voltmeter only. Therefore Synchronizing Plug must be removed for correct Voltmeter reading

Fig. 21.

There are several types on the market. One constructed for three-phase work, to be closed by hand and to be electrically tripped or opened by hand, is shown in Fig. 22. This shows the switch without the can containing the oil. Fig. 23 shows a similar switch hand-operated, with the can in place. Both of these switches are arranged to be mounted on the panel. Fig. 24 shows how the same switches are mounted when placed at some distance from the panel. For high voltages, they are placed in brick cells and often three separate single-pole switches are used, each placed in a separate cell so that injury to the contacts in one leg will in

no way affect the other parts of the switch. A form of oil switch used for the very highest potentials and currents met with in practice, is shown in Fig. 25. This particular switch is operated by means of an electric motor, though it may be as readily arranged to operate by means of a solenoid or by compressed air. General practice is to place all high-tension bus bars and circuits in separate compartments formed by brick or cement, and duplicate bus bars are quite common.

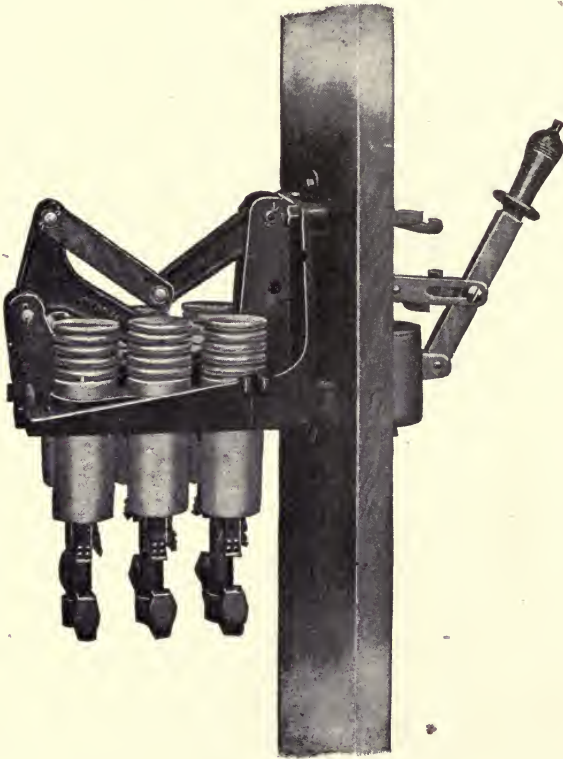

Fig. 22.

Oil switches are made automatic by means of tripping magnets, which are connected in the secondary circuits of current transformers, or they may be operated by means of relays fed from the secondaries of current transformers in the main leads. Such relays are made very compact and can be mounted on the



front or back of the switchboard panels. The wiring of such tripping devices is shown in Fig. 26.

With reinote control of switches, the switchboard becomes in many instances more properly a switch house, a separate building being devoted to the bus bars, switches, and connections. In other cases a framework of angle bars or gas pipe is made for the support of the switches, bus bars, current and potential transformers, etc.

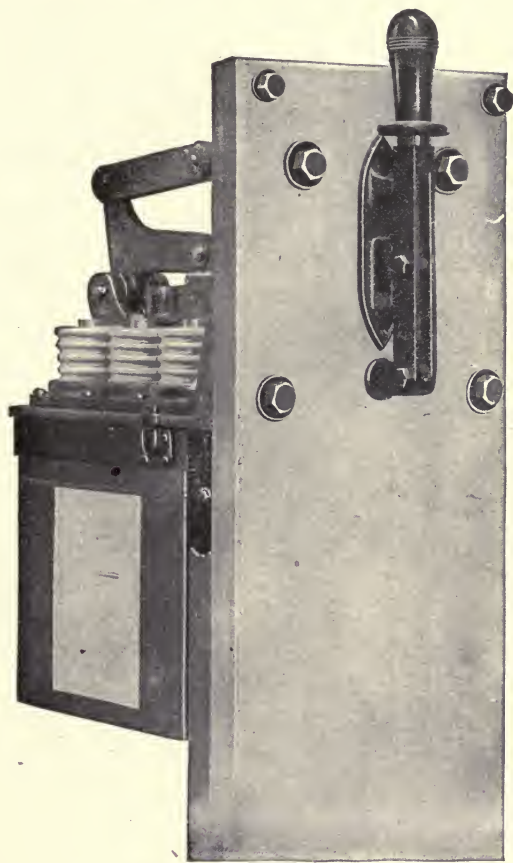
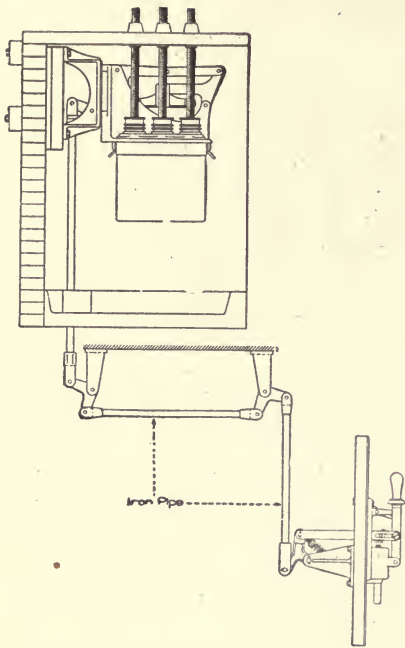

Fig. 23.

Additional types of panels which may be mentioned are transformer panels, usually containing switching apparatus only; rotary converter panels for both the alternating current and direct-current sides; induction-motor panels and arc-board panels. The latter





Form K Oil Switches Located Above and Back of Operating Panel.

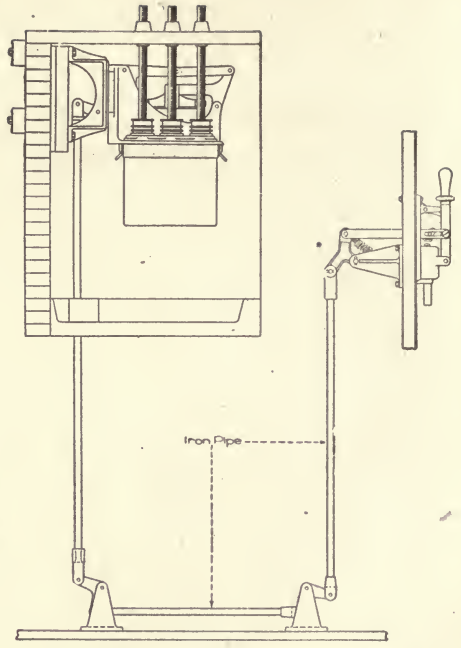

Form K Oil Switches Located Below and Back of Operating Panel.

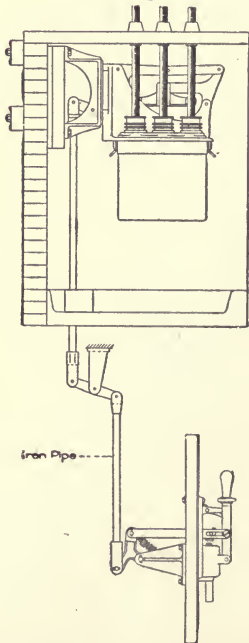

Form K Oil Switches Located Above Operating Panel.

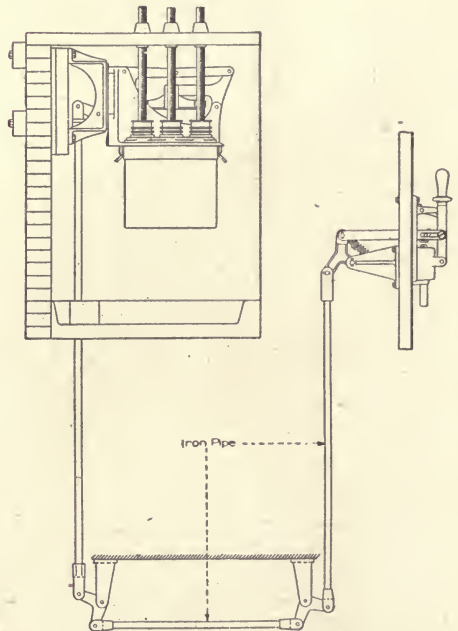

Form K Oil Switches Located Back of Operating Panel.

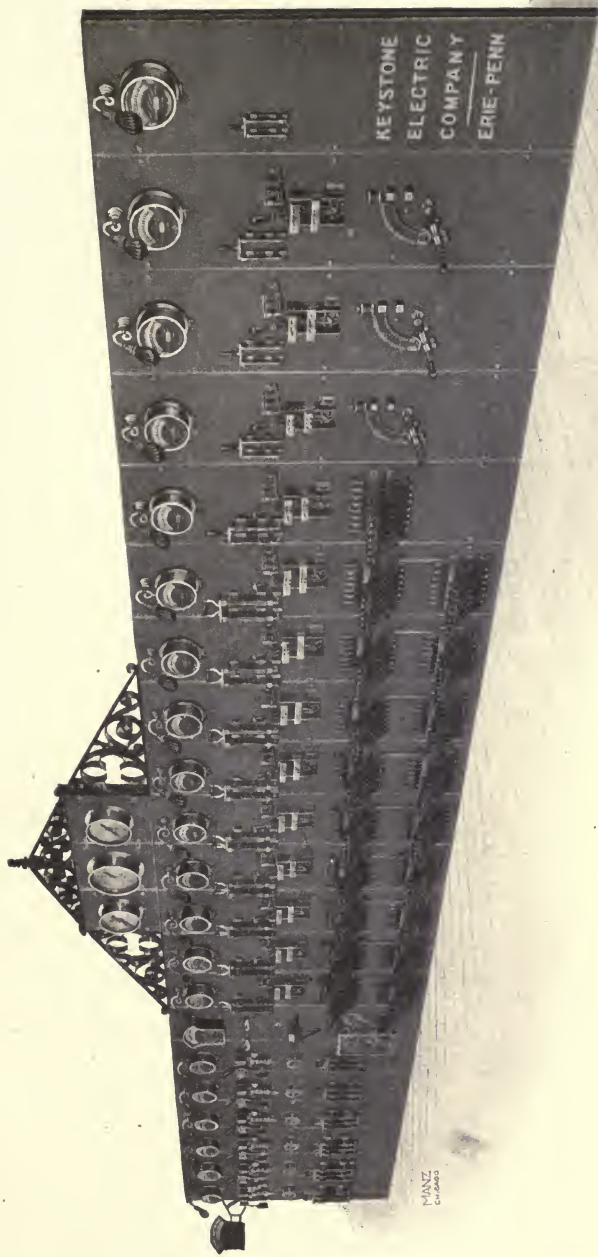

**SWITCHBOARD OF THE WHITEHALL PORTLAND CEMENT CO.**

Built and Installed by the Keystone Electric Co.

MANZ  
C-1000



LIBRARY  
OF THE  
UNIVERSITY  
OF  
CALIFORNIA

are arranged to operate with plug switches. A single panel used in the operation of series transformers on arc-lighting circuits is shown in Fig. 27.

**Safety Devices.** In addition to the ordinary overload tripping devices which have already been considered, there are various safety devices necessary in connection with the operation of central stations. One of the most important of these is the *lightning arrester*. For direct-current work, the lightning arrester takes the form of a single gap connected in series with a high resistance and fitted with some device for destroying the arc formed by discharge

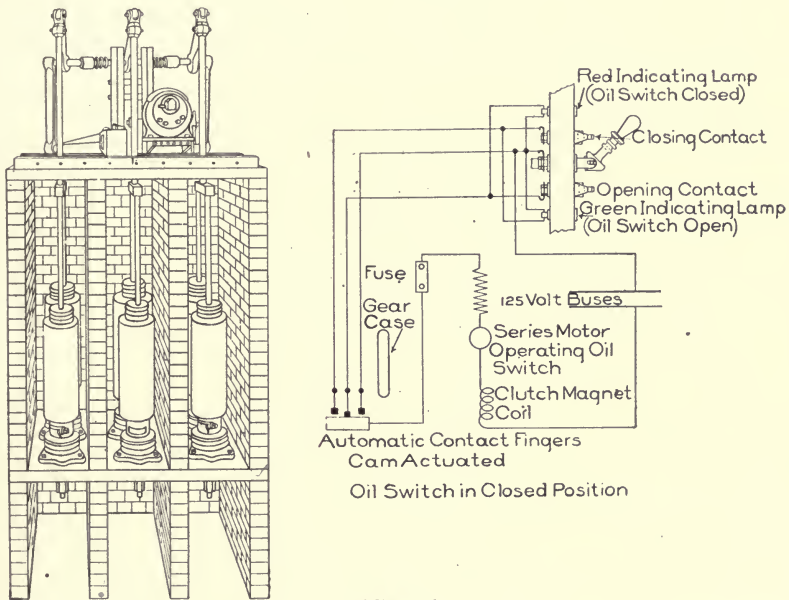

Fig. 25.

to the ground. One of these is connected between either side of the circuit and the ground, as shown diagrammatically in Fig. 28. A "kicking" coil is connected in circuit between the arresters and the machine to be protected, to aid in forcing the lightning discharge across the gap. In railway feeder panels such kicking coils are mounted on the backs of the panels.

For alternating-current work, several gaps are arranged in series, these gaps being formed between cylinders of "non-arcing" metal. High resistances and reactance coils are used with these,

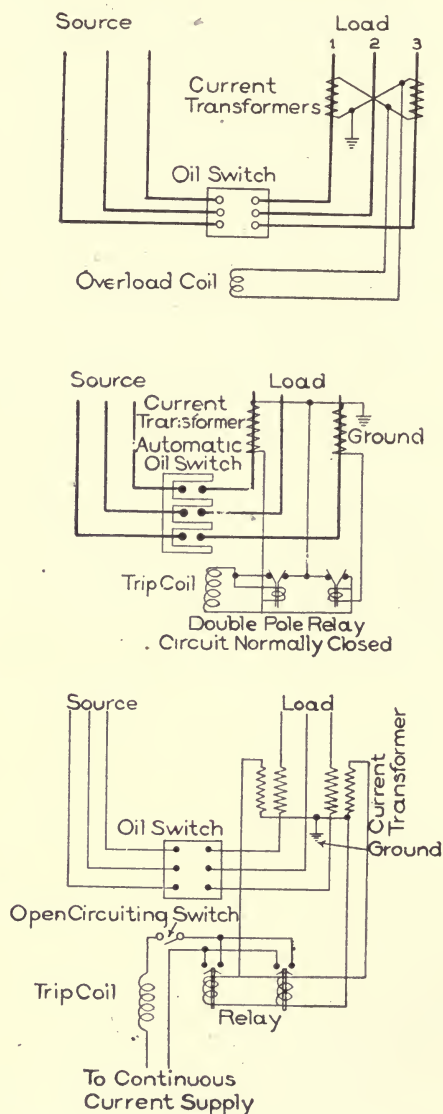

Fig. 26.

as in direct-current arresters. Fig. 29 shows connections for a 10,000-volt lightning arrester. Lightning arresters should always be provided with knife blade switches so that they can be disconnected from the circuit for inspection and repairs. A typical installation of lightning arresters is shown in Fig. 30.

Reverse-current relays are installed when machines or lines are operated in parallel. If two or more alternators are running and connected to the same set of bus bars, and one of these should fail to generate voltage by the opening of the field circuit, or some other cause, the other machine would feed into this generator and might cause considerable damage before the current flowing would be sufficient to operate the circuit breaker by means of the overload trip coils. To avoid this, reverse-current relays are used. They are so arranged as to operate at say  $\frac{1}{4}$  the normal current of the machine or

line, but to operate only when the power is being delivered in the wrong direction.

Speed limit devices are used on both engines and rotary converters to prevent racing in the one case and running away in the



second. Such devices act on the steam supply of engines and on the direct-current circuit breakers of rotary converters, respectively.

Complete wiring diagram for a railway switchboard is shown in Fig. 31.

**Substations.** Substations are for the purpose of transforming the high potentials down to such potentials as can be used on

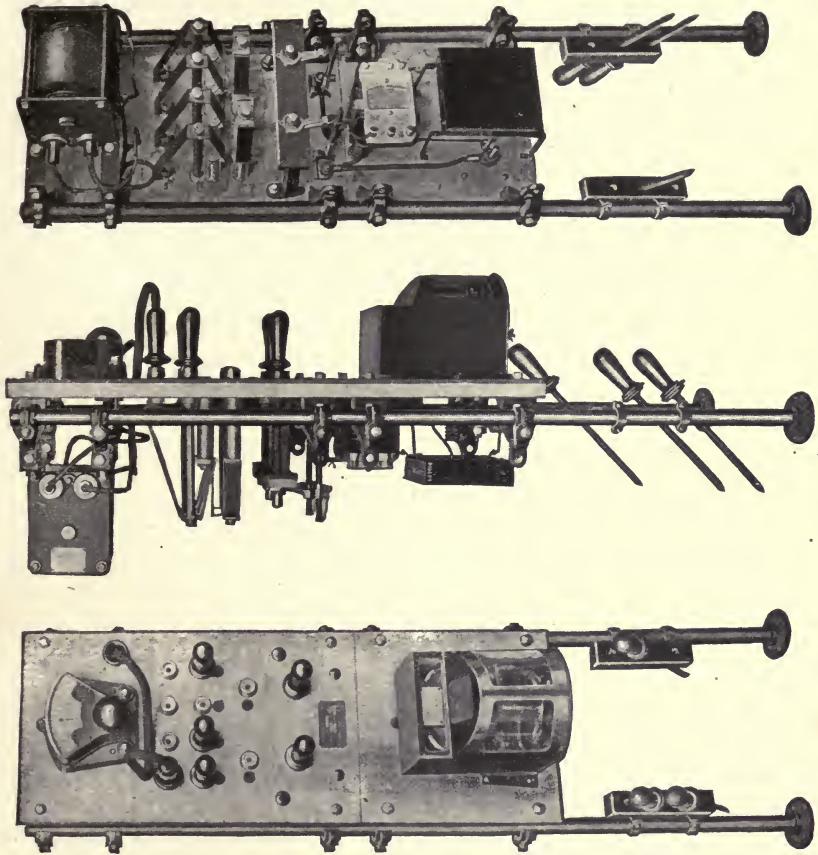

Fig. 27.

motors or lamps, and in many cases to convert alternating current into direct current. Step-down transformers do not differ in any respect from step-up transformers. Either motor-generator sets or rotary converters may be used to change from alternating to direct current. The former consist of synchronous or induction motors, direct connected to direct-current generators, mounted on

the same bedplate. The generator may be shunt or compound wound, as desired. Rotary converters are direct-current generators, though specially designed; they are fitted with collector rings attached to the winding at definite points. The alternating current is fed into these rings and the machine runs as a synchronous

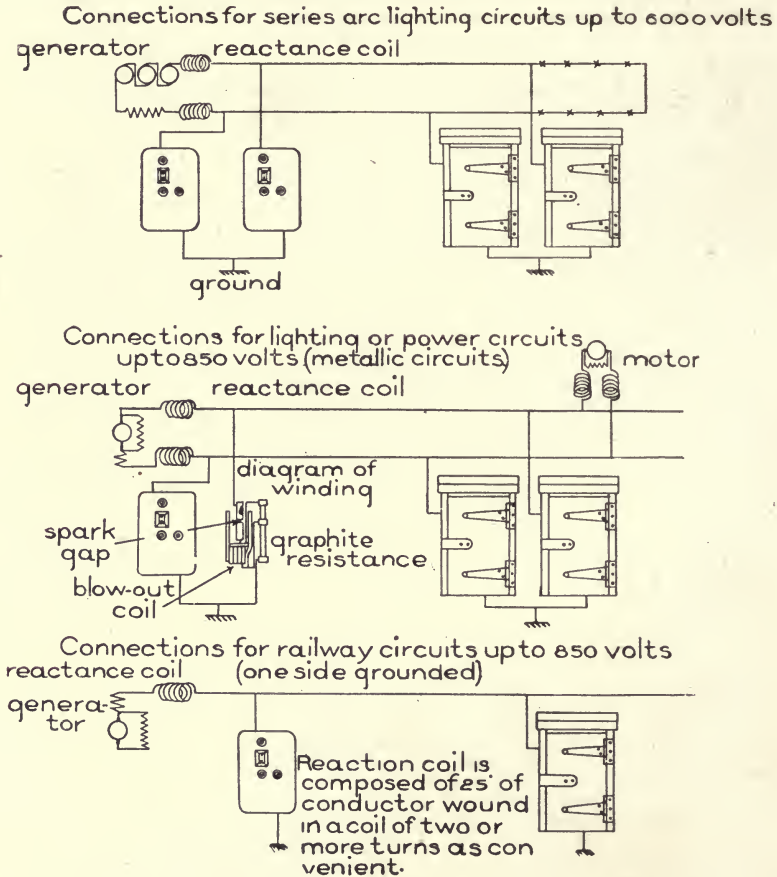
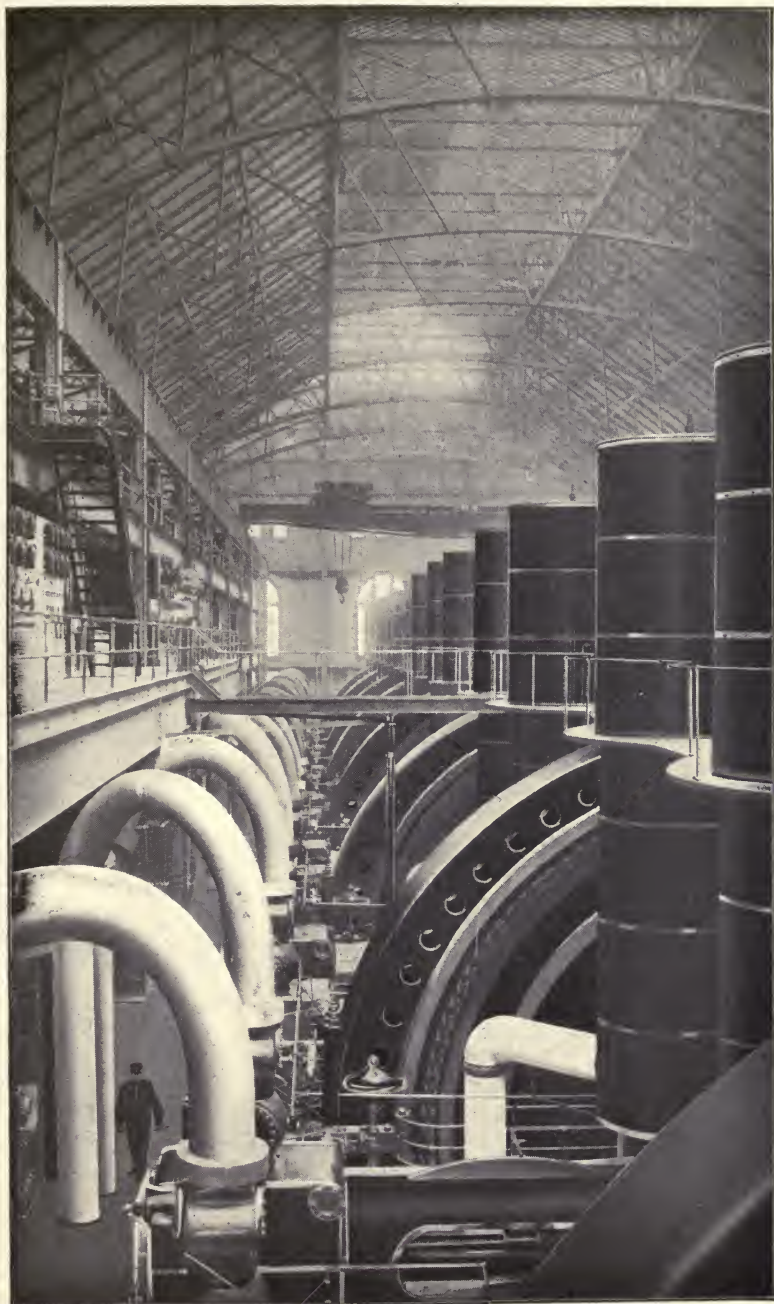

Fig. 28.

motor, while direct current is delivered at the commutator end. There is a fixed relation between the voltage applied to the alternating-current side and the direct-current voltage, which depends on the shape of the wave form, losses in the armature, pole pitch of the machine, method of connection, etc. The generally accepted values are as follows:



**MANHATTAN 74th ST. POWER STATION, NEW YORK.**  
Showing Carey's Carbonate of Magnesia Pipe Coverings. Steam Connections.





**TABLE 13.**  
**Full Load Ratios.**

Current.	Potential.
Continuous .....	100
Two-phase and Six-phase (diametrical) { 550 volts.....	72.5
{ 250 " .....	73
{ 125 " .....	73.5
Three-phase and Six-phase { 550 " .....	62
{ 250 " .....	62
{ 125 " .....	63

The increase of capacity of six-phase machines over other machines of the same size is given in Table 14.

This increase is due to the fact that, with a greater number of phases, less of the winding is traversed by the current which passes through the converter. The saving by increasing the number of phases beyond six is but slight and the system becomes too complex. Rotary converters may be over-compounded by the addition of series fields, provided the reactance in the alternating circuits be of a proper value. It is customary to insert reactance coils in the leads from the low-tension side of the step-down transformers to the collector rings to bring the reactance to a value which will insure the desired compounding.

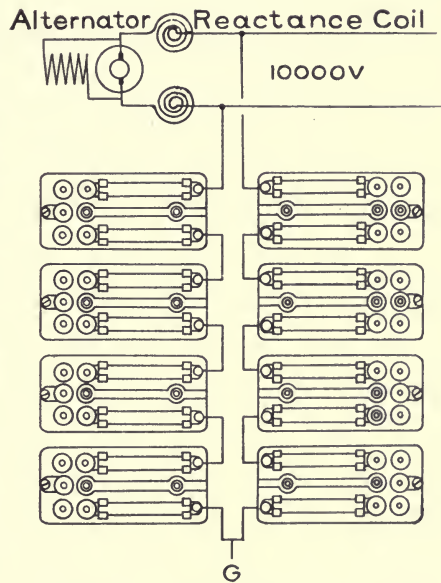

Fig. 29.

Again, the voltage may be controlled by means of induction regu-

**TABLE 14.**  
**Capacity Ratios.**

Continuous-current generator.....	100
Single-phase converter.....	85
Two-phase converter.....	164
Three-phase converter.....	134
Six-phase converter.....	196



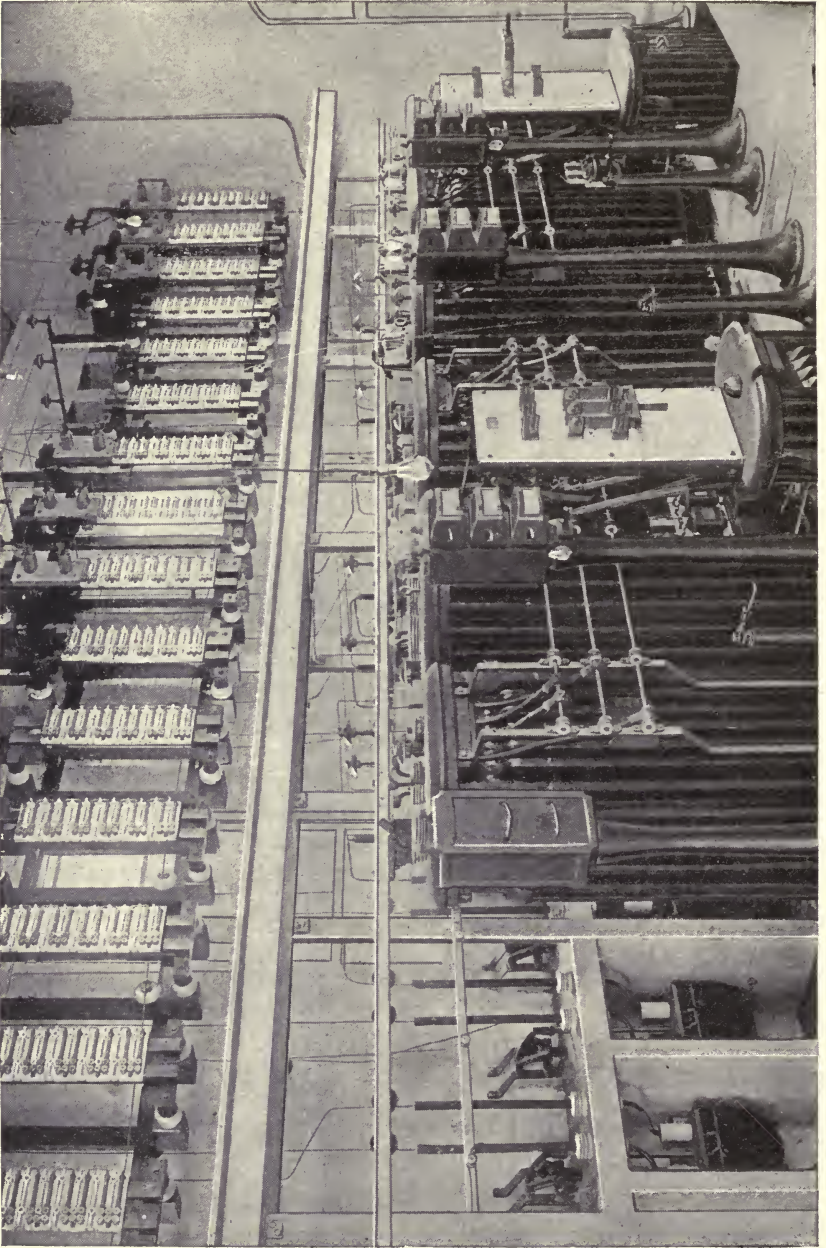

Fig. 30. 25,400-Volt Lightning Arrester Installation.

lators placed in the alternating-current leads. Motor-generators are more costly and occupy more space than rotary converters, but the regulation of the voltage is much better and they are to be preferred for lighting purposes.

**Buildings.** The power station usually has a building devoted entirely to this work, while the substations, if small, are often made a part of other buildings. While the detail of design and construction of the buildings for power plants belongs primarily to the architect, it is the duty of the electrical engineer to arrange the machinery to the best advantage, and he should always be consulted in regard to the general plans at least, as this may save much time and expense in the way of necessary modifications. The general arrangement of the machinery will be taken up later, but a few points in connection with the construction of the buildings and foundations will be considered here.

Space must be provided for the boiler,—this may be a separate building—engine and dynamo room, general and private offices, store rooms and repair shops. Very careful consideration should be given to each of these departments. The boiler room should be parallel with the engine room, so as to reduce the necessary amount of steam piping to a minimum, and if both rooms are in the same building a brick wall should separate the two, no openings which would allow dirt to come from the boiler room to the engine room being allowed. The height of both boiler and engine rooms should be such as to allow ample headway for lifting machinery and space for placing and repairing boilers, while provision should be made for extending these rooms in at least one direction. Both engine and boiler rooms should be fitted with proper traveling cranes to facilitate the handling of the units. In some cases the engines and dynamos occupy separate rooms, but this is not general practice. Ample light is necessary, especially in the engine rooms. The size of the offices, store rooms, etc., will depend entirely on local conditions.

The foundations for both the walls and the machinery must be of the very best. It is well to excavate the entire space under the engine room to a depth of eight to ten feet so as to form a basement, while in most cases the excavations must be made to a greater depth for the walls. Foundation trenches are sometimes

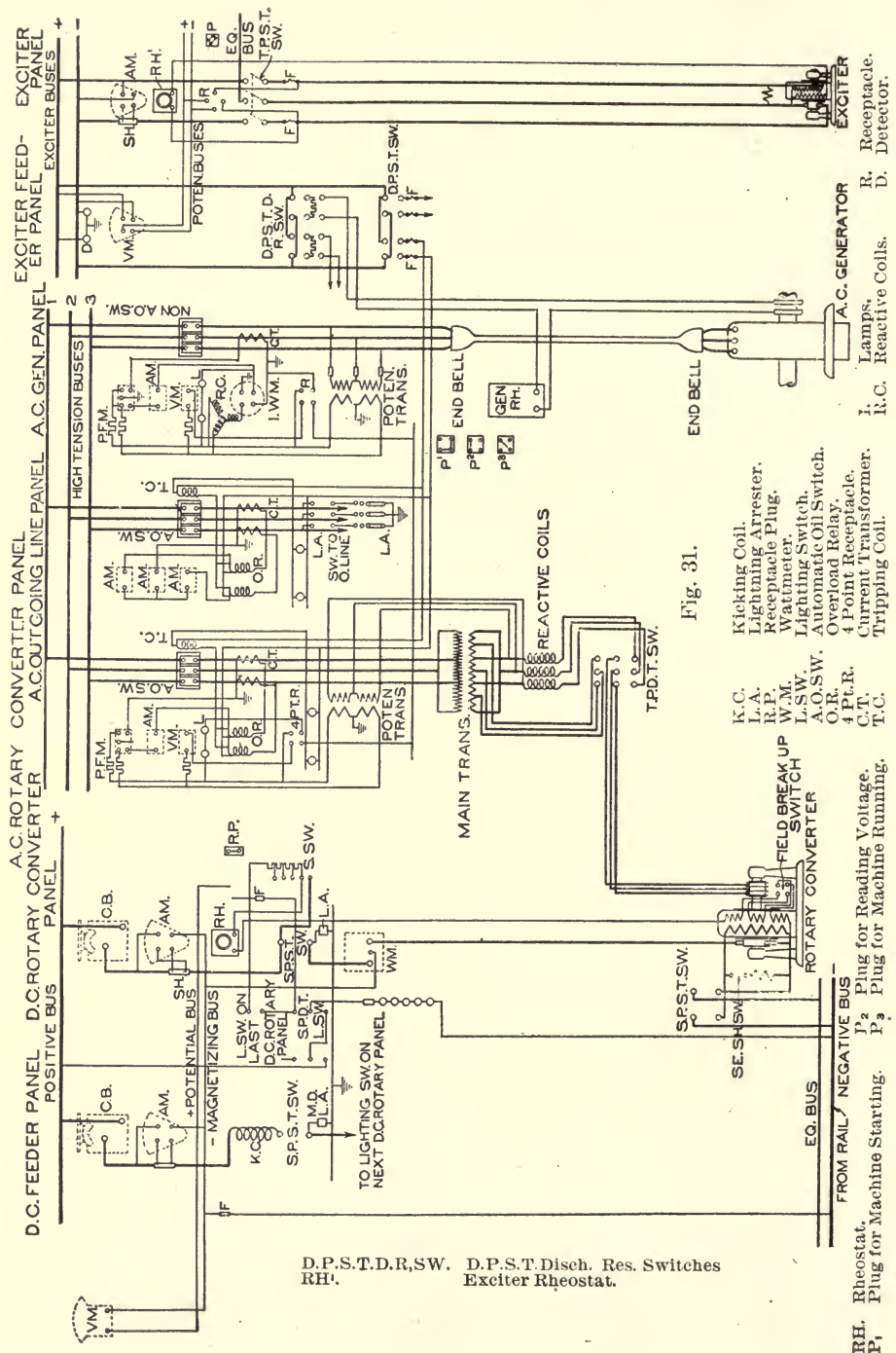

Fig. 31.

D.P.S.T.D.R.S.W. D.P.S.T. Disch. Res. Switches  
 RH. Exciter Rheostat.

- K.C. Kicking Coil.
- L.A. Lightning Arrester.
- R.P. Receptacle Plug.
- W.M. Wattmeter.
- L.S.W. Lighting Switch.
- A.O.S.W. Automatic Oil Switch.
- O.R. Overload Relay.
- 4 Pt. R. 4 Point Receptacle.
- C.T. Current Transformer.
- T.C. Tripping Coil.
- A.C. GENERATOR
- Lamps.
- R. Receptacle.
- D. Detector.

RH. Rheostat.  
 P<sub>1</sub> Plug for Machine Starting.  
 P<sub>2</sub> Plug for Reading Voltage.  
 P<sub>3</sub> Plug for Machine Running.



filled with concrete to a depth sufficient to form a good underfooting. The area of the foundation footing should be great enough to keep the pressure within a safe limit for the quality of the soil.

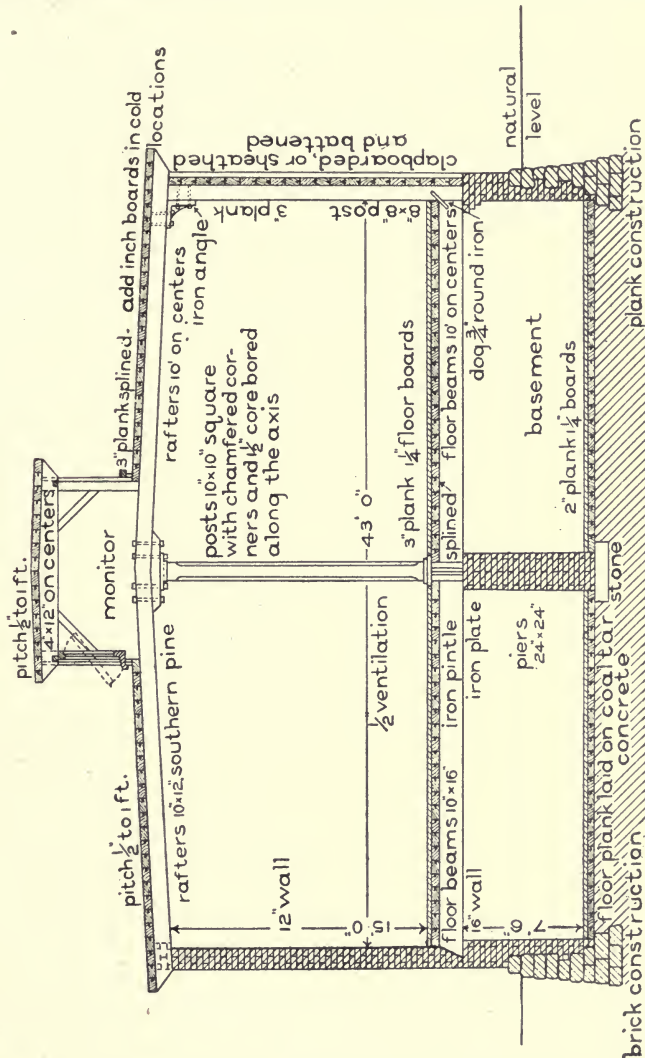

Fig. 32.

The walls themselves may be of wood, brick, stone, or concrete. Wood is used for very small stations only, while brick may be used alone or in conjunction with steel framing, the latter construction being used to a considerable extent. If brick alone is

used, the walls should never be less than twelve inches thick, and eighteen to twenty inches is better for large buildings. They must be amply reinforced with pilasters. Stone is used only for the most expensive stations. The interior of the walls is formed of glazed brick, when the expense of such construction is warranted. In fireproof construction, which is always desirable for power stations, the roofs are supported by steel trusses and take a great variety of forms. Fig. 32 shows what has been recommended as standard construction for lighting stations, showing both brick and wood construction. The floors of the engine room should be

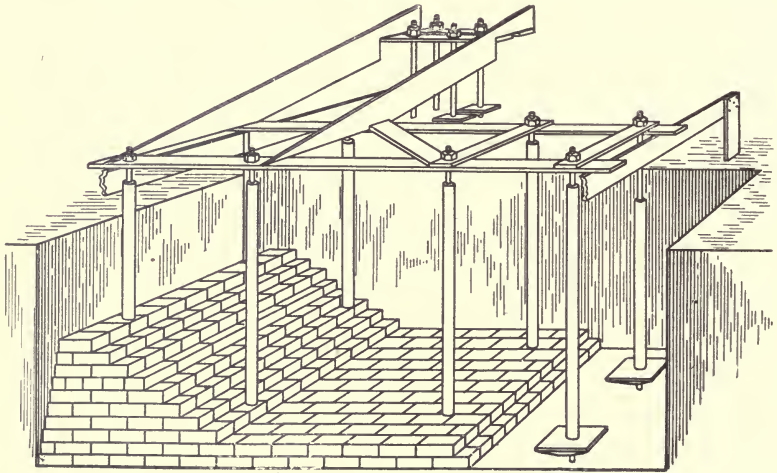

Fig. 33.

made of some material which will not form grit or dust. Hard tile, unglazed, set in cement or wood floors, is desirable. Storage battery rooms should be separate from all others and should have their interior lined with some material which will not be affected by the acid fumes. The best of ventilation is desirable for all parts of the station, but is of particular importance in the dynamo room if the machines are being heavily loaded. Substation construction does not differ from that of central stations when a separate building is erected. They should be fireproof if possible.

The foundations for machinery should be entirely separate from those of the building. Not only must the foundations be stable, but in some locations it is particularly desirable that no



vibrations be transmitted to adjoining rooms and buildings. A loose or sandy soil does not transmit such vibrations readily, but firm earth or rock transmits them almost perfectly. Sand, wool, hair, felt, mineral wool, and asphaltum concrete are some of the materials used to prevent this. The excavation for the foundation is made from two to three feet deeper and two to three feet wider on all sides than the foundation, and the sand, or whatever material is used, occupies this extra space.

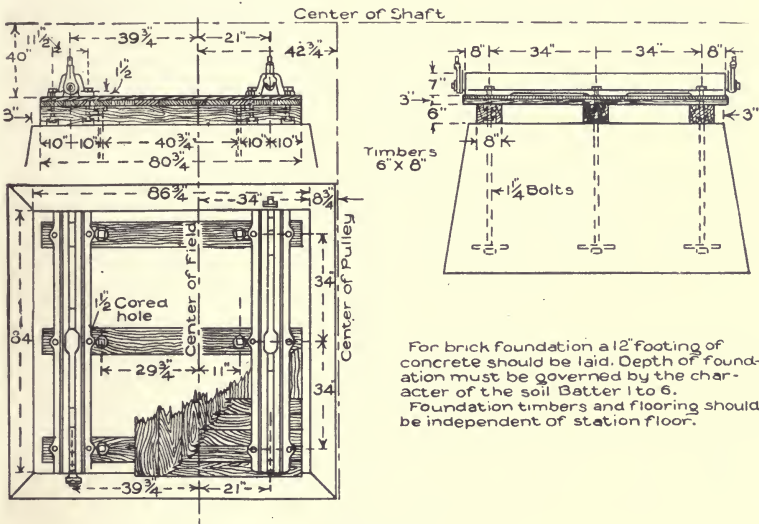

For brick foundation a 12" footing of concrete should be laid. Depth of foundation must be governed by the character of the soil Batter 1 to 6. Foundation timbers and flooring should be independent of station floor.

Fig. 34.

Brick, stone, or concrete is used for building up the greater part of machinery foundations, the machines being held in place by means of bolts fastened in masonry. A template, giving the location of all bolts to be used in holding the machine in place, should be furnished, and the bolts may be run inside of iron pipes with an internal diameter a little greater than the diameter of the bolt. This allows some play to the bolt and is convenient for the final alignment of the machine. Fig. 33 gives an idea of this construction. The brickwork should consist of hard-burned brick of the best quality, and should be laid in cement mortar. It is well to fit brick or concrete foundations with a stone cap, forming a level surface on which to set the machinery, though this is not necessary. Generators are sometimes mounted on wood bases to

furnish insulation for the frame. Fig. 34 shows the foundation for a 150 K.W. generator, while Fig. 35 shows the foundation for a rotary converter.

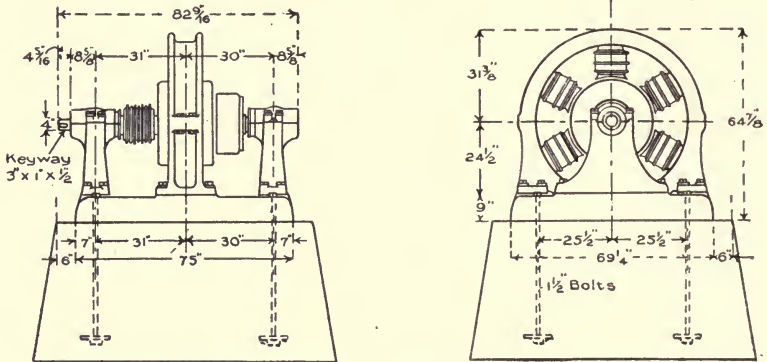

For brick foundation a 12" footing of concrete should be laid. Depth of foundation must be governed by the character of the soil. Batter 1 to 6".

Fig. 35.

**Station Arrangement.** A few points have already been noted in regard to station arrangement, but the importance of the subject demands a little further consideration. Station arrangement depends chiefly upon two facts—the location and the machinery to be installed. Undoubtedly the best arrangement is with all of the machinery on one floor with, perhaps, the operating switchboard mounted on a gallery so that the attendants may have a clear view of all the machines. Fig. 36 shows the simplest arrangement of a plant using belted machines. Fig. 37 shows an arrangement of units where a jack shaft is used. Direct-current machines should be placed so that the brushes and commutators are easily accessible and the switchboard should be placed so as to not be liable to accidents, such as the breaking of a belt or a fly-wheel.

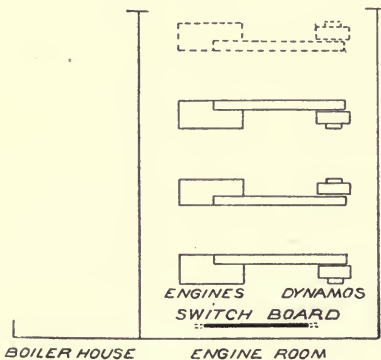

Fig. 36.

where a jack shaft is used. Direct-current machines should be placed so that the brushes and commutators are easily accessible and the switchboard should be placed so as to not be liable to accidents, such as the breaking of a belt or a fly-wheel.

When the cost of real estate prohibits the placing of all of the machinery on one floor, the arrangements shown in Fig. 38 may be used when the machines are belted. It is always desirable to have the engines on the main floor, as they cause considerable vibration when not mounted on the best of foundations. The boilers, while heavy, do not cause such vibration and they may be placed on the second or third floor. Belts should not be run vertically, as they must be stretched too tightly to prevent slipping.

Fig. 39 shows a large station using direct-connected units, while Fig. 40 shows the arrangement of the turbine plant of the Boston Edison Electric Illuminating Company. This station will contain twelve such 5,000 K.W. units when completed. Note the arrangement of boilers when several units are required for a single prime mover.

The use of a separate room or building for the cables, switches, and operating boards is becoming quite common for high-tension generating plants. The remarkable saving in floor space brought about by the turbine is readily seen from Fig. 41. The total floor space occupied by the new Boston station is 2.64 square feet per K.W. This includes boilers—of which there are eight, each 512 H.P. for each unit—turbines, generators, switches, and all auxiliary apparatus.

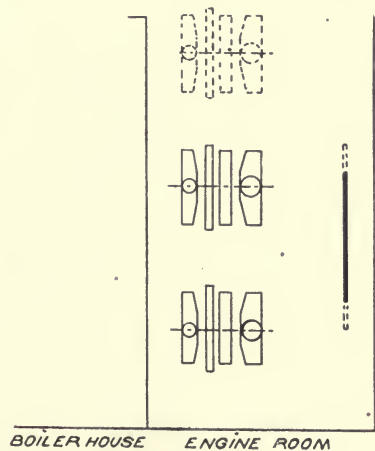

Fig. 39.

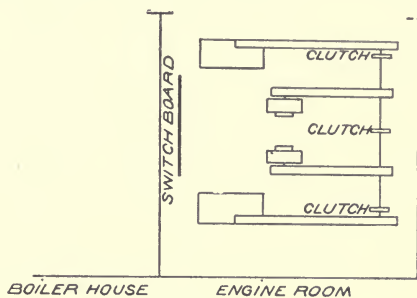

Fig. 37.

The use of a separate room or building for the cables, switches, and operating boards is becoming quite common for high-tension generating plants. The remarkable saving in floor space brought about by the turbine is readily seen from Fig. 41. The total floor space occupied by the new Boston station is 2.64 square feet per K.W. This includes boilers—of which there are eight, each 512 H.P. for each unit—turbines, generators, switches, and all auxiliary apparatus.

When transformers are used for raising the voltage, they may be placed in a separate building, as is the case at Niagara Falls, or the transformers may be located in some part of the dynamo room, preferably in a line parallel to the generators.

Fig. 42 shows the arrangement of units in an hydraulic plant. Fig. 43 is a good example of the practice in substation arrangement. Here the switchboard is mounted at one end of the room, while the rotary converters and transformers are arranged along either side of the building.

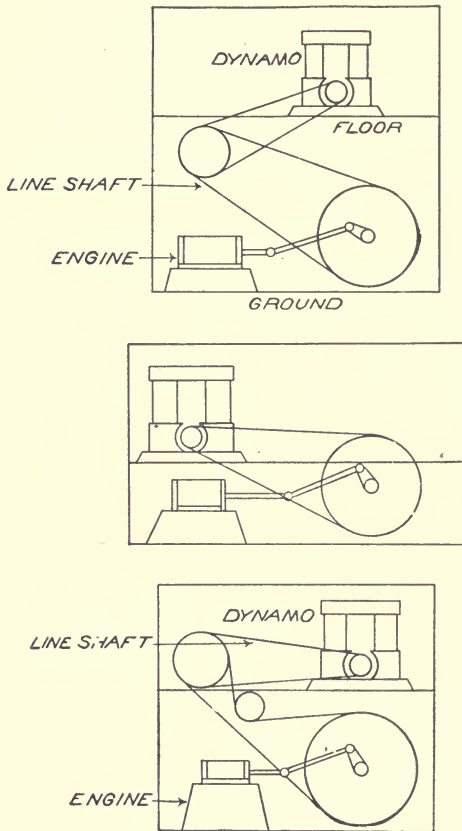

Fig. 38.

Large cable vaults are installed at the stations operating on underground systems, the separate ducts being spread out, and sheet-iron partitions erected to prevent damage being done to cables which were not originally defective, by a short circuit in any one feeder.

**Station Records.** In order to accurately determine the cost of generating power and to check up on uneconomical or improper methods of operation and lead to their improvement, accurately kept station records are of the utmost importance. Such records should consist of switchboard records, engine-room records, boiler-room records, and distributing-system records. Such records accu-

ately kept and properly plotted in the form of curves, serve admirably for the comparison of station operations from day to day and for the same periods for different years. It pays to keep these records even when additional clerical force must be employed.

Switchboard records consist, in alternating stations, of daily readings of feeder, recording wattmeters, and total recording watt-

meter, together with voltmeter and ammeter readings at intervals of about 15 minutes in some cases to check upon the average power factor and determine the general form of the load curve. For direct-current lighting systems volt and ampere readings serve to give the true output of the stations, and curves are readily plotted from these readings. The voltage should be recorded for the bus bars as well as for the centers of distribution.

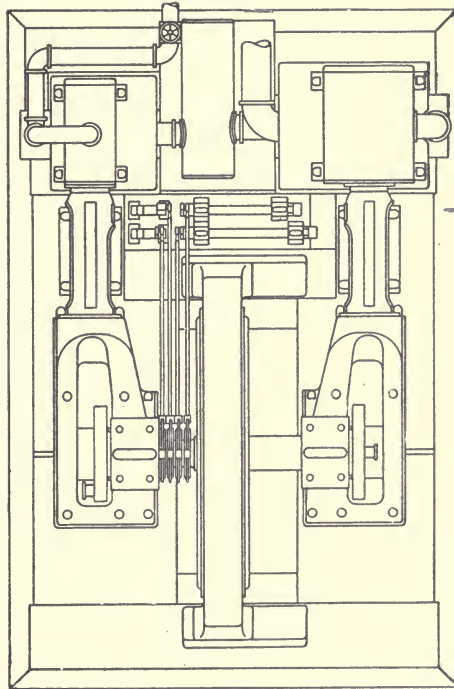
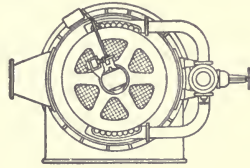

Fig. 41. Comparison of 1500 K.W. Corliss Engine and 1500 K.W. Curtis Turbine.

Indicator diagrams should be taken from the engines at frequent intervals for the purpose of determining the operation of the valves. Engine-room records include labor, use of waste oil and supplies, as well as all repairs made on engines, dynamos and auxiliaries.



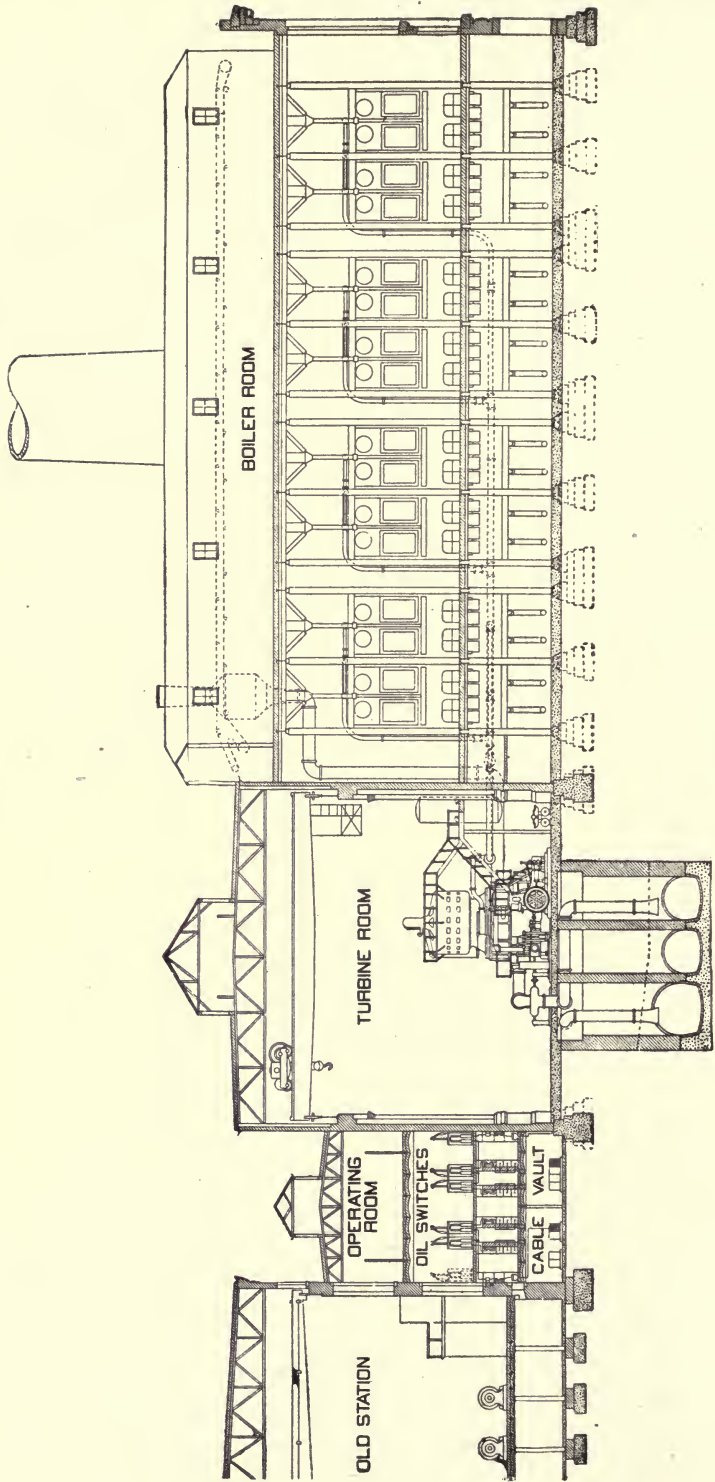

Fig. 40.

TURBINE ROOM

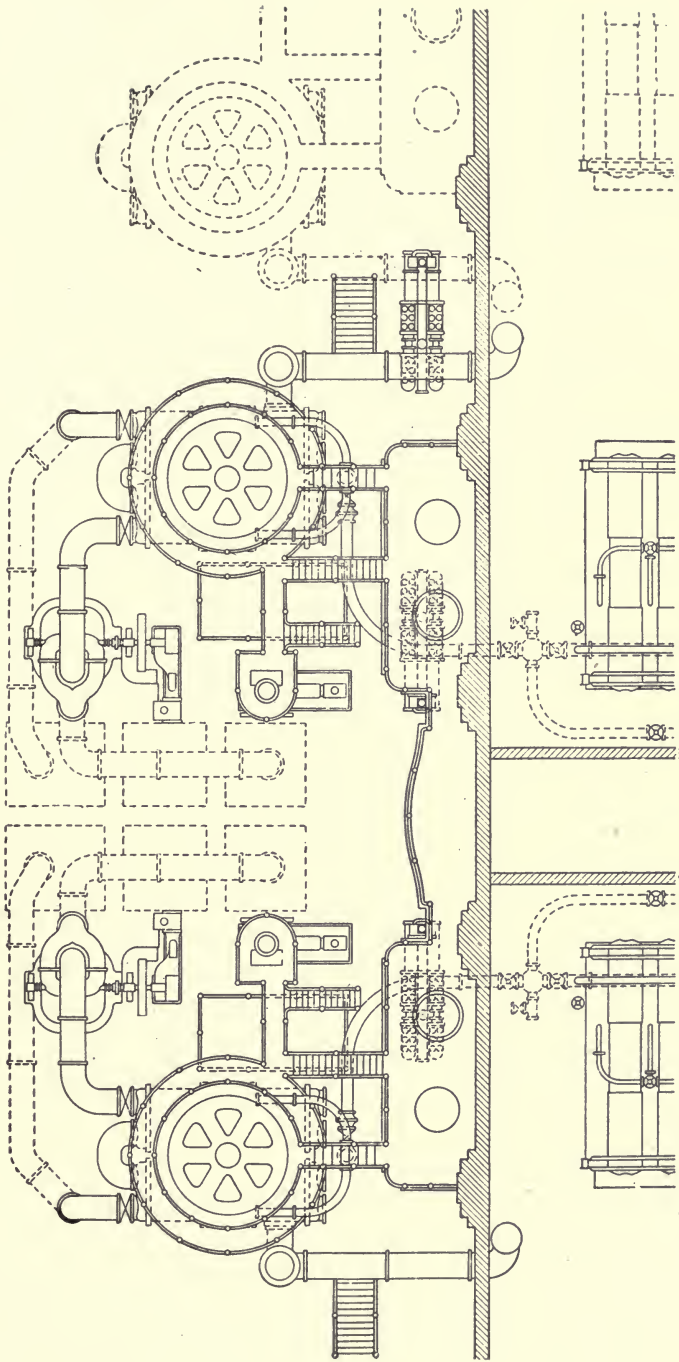

Fig. 40.

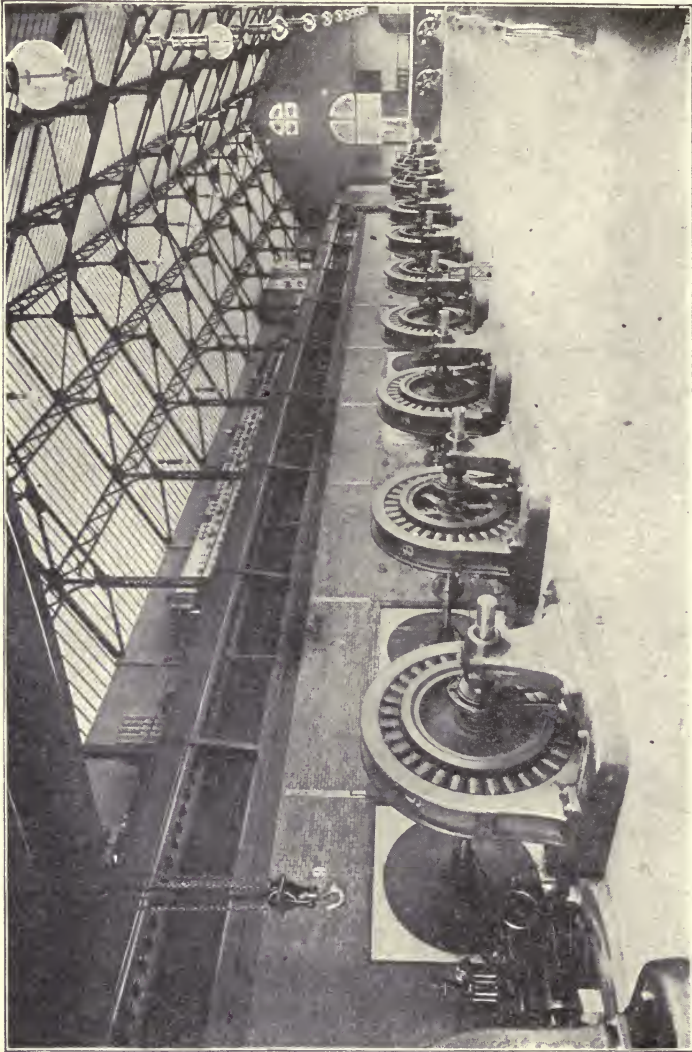

Fig. 42.

Boiler-room records include labor and repairs, amount of coal used, which amount may be kept in detail if desirable, amount of water used, together with steam-gauge record and periodical analysis of flue gases as a check on the methods of firing.

Records for the distributing system include labor and material used for the lines and substations. For multiple-wire

systems, frequent readings of the current in the different feeders will serve as a check on the balance of the load.

The cost of generating power varies greatly with the rate at which it is produced as well as upon local conditions. Station operating expenses include cost of fuel, water, waste, oil, etc., cost of repairs, labor, and superintendence. Fixed charges include, insurance, taxes, interest on investment, depreciation, and general office expenses. Total expenses divided by total kilowatt hours gives the cost of generation of a kilowatt hour. The cost of distributing a kilowatt hour may be determined in a similar manner. The rate of depreciation of apparatus differs greatly with different machines, but the following figures may be taken as average values, these figures representing percentage of first cost to be charged up each year :

- Fireproof buildings from 2 to 3 per cent.
- Frame buildings from 5 to 8 per cent.
- Dynamos from 2 to 4 per cent.
- Prime movers from  $2\frac{1}{2}$  to 5 per cent.
- Boilers from 4 to 5 per cent
- Overhead lines, best constructed, 5 to 10 per cent.
- More poorly constructed lines 20 to 30 per cent
- Badly constructed lines 40 to 60 per cent
- Underground conduits 2 per cent.
- Lead covered cables 2 per cent.

**Methods of Charging for Power.** There are four methods used for charging consumers for electrical energy, namely, the flat-rate or contract system, the meter system, the two-rate meter system, and a system by which each customer pays a fixed amount depending on the maximum demand and in addition pays at a reasonable rate for the power actually used. In the flat-rate system, each customer pays a certain amount a year for service, this amount being based on the estimated amount of power to be used. These rates vary, depending on the hours of the day during which the power is to be used, being greatest if the energy is to be used during peak hours. It is an unsatisfactory method for lighting service, as many customers are liable to take advantage of the company, burning more lights than contracted for and at different hours, while the honest customer must pay a higher rate than is reasonable in order to make the station operation profitable.



This method serves much better when the power is used for driving motors, and is used largely for this class of service.

The simple meter method of charging serves the purpose better for lighting, but the rate here is the same no matter what hour of the day the current is used. Obviously, since machinery

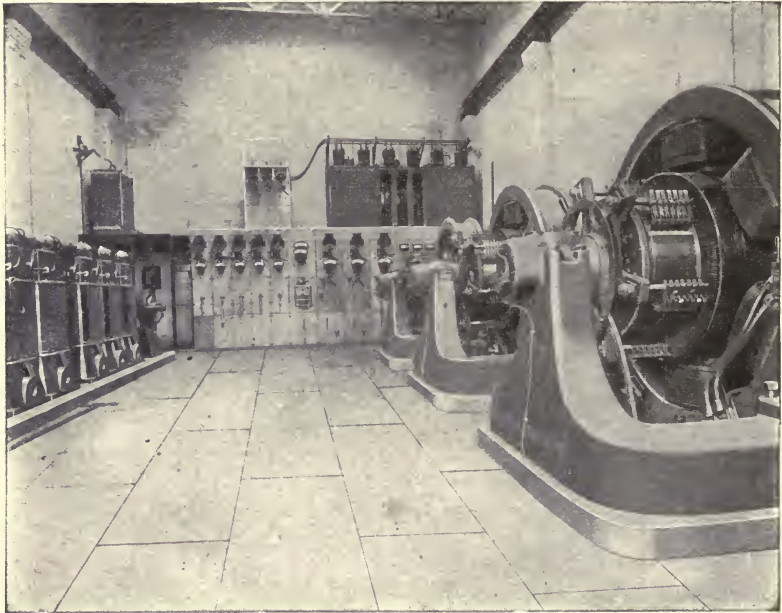

Fig. 43.

is installed to carry the peak of the load, any power used at this time tends to increase the capital outlay from the plant, and users should be required to pay more for the power at such times.

The two-meter rate accomplishes this purpose to a certain extent. The meters are arranged so that they record at two rates, the higher rate being used during the hours of heavy load.

There are several methods of carrying out the fourth scheme. In the Brighton System, a fixed charge is made each month, depending on the maximum demand for power during the previous month, a regular schedule of such charges being made out, based on the cost of the plant. An integrating wattmeter is used to record the energy consumed, while a so-called "demand meter" records the maximum rate of demand.







**WESTINGHOUSE TWO-PHASE GENERATORS, DIRECT-CONNECTED.**  
Metropolitan Electric Supply Co., Ltd., London, England.

# POWER TRANSMISSION.

## ELECTRICAL.

---

The subject of power transmission is a very broad one; dealing with the transmission and distribution of electrical energy, as generated by the dynamo or alternating-current generator, to the receivers. The receivers may be lamps, motors, electrolytic cells, etc. Electric distribution of power is better than other systems on account of its superior flexibility, efficiency, and effectiveness; and we find it taking the place of other methods in all but a very few applications. For some purposes the problem is comparatively simple, while for other uses, such as supplying a large system of incandescent lamps, scattered over a comparatively large area, it is quite complicated. As with other branches of electrical engineering, it is only in recent years that any great advances have been made in the means employed for transmission of electrical power, and while this advance has been very rapid, there is still a large field for development.

In a study of this subject the different methods employed and their application, the most efficient systems to be installed for given service, the preparation of conductors and the calculation of their size, together with the proper installation of the same, should be considered.

### CONDUCTORS.

**Material Used.** Power, in any appreciable amount, is transmitted, electrically, by the aid of metal wires, cables, tubes, or bars. The materials used are iron or steel, copper and aluminum. Other metals may serve to conduct electricity but they are not applied to the general transmission of energy. Of these three, the two latter are the most important, iron or steel being used to a considerable extent only in the construction of telephone and telegraph lines, and even here they are rapidly giving way to copper. Steel may be used in some special cases, such as extremely long spans in overhead construction or for the working conductors for railway installations using a third rail. Phosphor bronze has a limited use on account of its mechanical strength.

Copper and aluminum are used in the commercially pure state and are selected on account of their conductivity and comparatively low cost. The use of aluminum is at present limited to long-distance transmission lines or to large bus-bars, and is selected on account of its being much lighter than copper. It is not used for insulated conductors because of its comparatively large cross-section and consequent increase in amount of insulation necessary.

TABLE I.  
Copper Wire Table.

A. W. G. or B. & S.	Dimensions.		Resistance.		
	Diameter.	Area.	Ohms per foot.		
	Inches.	Circular Mils.	At 20° C.	At 50° C.	At 80° C.
0000	.460	211,600	.00004893	.00005467	.00006058
000	.4096	167,800	.00006170	.00006893	.00007640
00	.3648	133,100	.00007780	.00008692	.00009633
0	.3249	105,500	.00009811	.0001096	.0001215
1	.2893	83,690	.0001237	.0001382	.0001532
2	.2576	66,370	.0001560	.0001743	.0001932
3	.2294	52,630	.0001967	.0002198	.0002435
4	.2043	41,740	.0002480	.0002771	.0003071
5	.1819	33,100	.0003128	.0003495	.0003873
6	.1620	26,250	.0003944	.0004406	.0004883
7	.1443	20,820	.0004973	.0005556	.0006158
8	.1285	16,510	.0006271	.0007007	.0007765
9	.1144	13,090	.0007908	.0008835	.0009791
10	.1019	10,380	.0009972	.001114	.001235
11	.09074	8,234	.001257	.001405	.001557
12	.08081	6,530	.001586	.001771	.001963
13	.07196	5,178	.001999	.002234	.002476
14	.06408	4,107	.002521	.002817	.003122
15	.05707	3,257	.003179	.003552	.003936
16	.05082	2,583	.004009	.004479	.004964
17	.04526	2,048	.005055	.005648	.006259
18	.04030	1,624	.006374	.007122	.007892

**Resistance.** The resistance of electrical conductors is expressed by the formula:

$$R = \frac{L}{A} f$$

where  $R$  = total resistance of the conductors considered.  
 $L$  = length of the conductors in the units chosen.  
 $A$  = area of the conductors in the units chosen.  
 $f$  = a constant depending on the material used and on the units selected.



For cylindrical conductors, L is usually expressed in feet and A in circular mils. By a circular mil is meant the area of a circle .001 inches in diameter. A square mil is the area of a square whose sides measure .001 inches and is equivalent to 1.27 circular mils. Cylindrical conductors are designated by gauge number or by their diameter. The Brown & Sharpe (B. & S.) or American wire gauge is used almost universally and the diameters corresponding to the different gauge numbers are given in Table I. Wires above No. 0000. are designated by their diameter or by their area in circular mils.

TABLE II.

## Resistances of Pure Aluminum Wire.

A. W. G. OR B. & S.	Resistance at 75° F.	
	R Ohms 1,000 ft.	Ohms per mile.
0000	.08177	.43172
000	.10310	.54440
00	.13001	.68345
0	.16385	.86515
1	.20672	1.09150
2	.26077	1.37637
3	.32872	1.7357
4	.41448	2.1885
5	.52268	2.7597
6	.65910	3.4802
7	.83110	4.3885
8	1.06802	5.5355
9	1.32135	6.9767
10	1.66667	8.8000
11	2.1012	11.0947
12	2.6497	13.9900
13	3.3412	17.642
14	4.3180	22.800
15	5.1917	27.462
16	6.6985	35.368
17	8.4472	44.602
18	10.6518	56.242

A convenient way of determining the size of a conductor from its gauge number is to remember that a number 10 wire has a diameter of nearly one-tenth of an inch and the cross-section is doubled for every three sizes larger (Nos. 7, 4, etc.) and one-half as great for every three sizes smaller (Nos. 13, 16, etc.). 1,000



feet of number 10 copper wire has a resistance of 1 ohm and weighs 31.4 pounds.

When  $f$  is expressed in terms of the mil foot, a wire one foot in length having a cross-section of one mil, its value for copper of a purity known as **Matthiessen's Standard**, or copper of 100% conductivity, is 9.586 at 0° C.\* For aluminum its value is given as 15.2 for aluminum 99.5% pure. Table II gives the resistance of aluminum wire.

This shows the conductivity of aluminum to be about 63% of that of copper. The conductivity of iron wire is about  $\frac{1}{7}$  that of copper.

Matthiessen's standard is based on the resistance of copper supposed, by Matthiessen, to be pure. Since his experiments, improvements in the refining of copper have made it possible to produce copper of a conductivity exceeding 100%. Copper of a conductivity lower than 98% is seldom used for power transmission purposes.

**Temperature Coefficient.** The specific resistance (resistance per mil foot) is given for copper as 9.586 at 0° Centigrade. Its resistance increases with the temperature according to the approximate formula:

$$R_t = R_o(1 + at)$$

where  $R_t$  = Resistance at temperature  $t^\circ$ , Centigrade.

$$R_o = \quad \quad \quad \quad \quad \quad 0^\circ \text{ C.}$$

$$a = .0042, \text{ commercial value.}$$

The value of  $a$  for aluminum does not differ greatly from this. It is given by Kempe as .0039.

**Weight.** The specific gravity of copper is 8.89. The value for aluminum is 2.7, showing aluminum to weigh .607 times as much as copper for the same conductivity or resistance. It is this property which makes its use desirable in special cases. Iron, as used for conductors, has a specific gravity of 7.8.

**Mechanical Strength.** Soft-drawn copper has a tensile strength of 25,000 to 35,000 lbs. per sq. in. Hard-drawn copper has a tensile strength of 50,000 to 70,000 lbs. per sq. in., depending on the size; the lower value corresponding to Nos. 0000 and 000.

\*The commercial values given for the mil foot vary from 10.7 to 11 ohms.

Aluminum has a tensile strength of about 33,000 lbs. per sq. in. for hard-drawn wire  $\frac{1}{4}$  inch in diameter.

**Effects of Resistance.** The effect of resistance in conductors is three-fold.

1. There is a drop in voltage, determined from Ohm's law,

$$I = \frac{E}{R} \text{ or } E = IR.$$

2. There is a loss of energy proportional to the resistance and the square of the current flowing. Loss in watts =  $I^2R = \frac{E^2}{R}$

3. There is a heating of the conductors, due to the energy lost, and the amount of heating allowable depends on the material surrounding the conductors. The drop in voltage or the heating limit is usually more important in the design of a transmission system than the loss of energy.

**Capacity of Conductors for Carrying Current.** The temperature of a conductor will rise until heat is lost at a rate equal to the rate it is generated so that a conductor is only capable of carrying a certain current with a given allowable temperature rise. The limit of this rise in temperature is determined by fire risk, or injury to insulation. A general rule is that the current density should not exceed 1,000 amperes per square inch of cross-section for copper conductors. This value is too low for small wire and too high for heavy conductors, and it is governed by the way in which the conductors are installed. This value serves for bus-bars where the thickness of the copper used is limited to  $\frac{1}{4}$ -inch. Curves shown in Fig. 1 are applicable to switchboard wiring, and Table VII of "Electric Wiring" gives safe carrying capacity of conductors for inside wiring. Perrine gives the following table showing the class of conductors to be used under various conditions:

TABLE III.  
Conductors for Various Conditions.

PART I.

Reference No.	Remarks.	Reference No.	Remarks.
1.	Not allowed.	8.	In insulating tubes.
2.	Clear spaces.	9.	In wood moldings.
3.	Through trees.	10.	Without further precaution.
4.	On glass insulators.	11.	If necessary.
5.	On porcelain knobs.	12.	Below 350 volts.
6.	In porcelain cleats.	13.	Above 350 volts.
7.	In wood cleats.		

TABLE III.  
Class of Conductors for Various Positions.  
PART II.

Description of Conductor.	Position.						
	Open air.	Dry rooms.	Damp rooms.	Concealed under floor or wall.	Rooms containing gases or vapor.	Under water.	Underground. Buried. In conduit.
Bare wire.....	{ 2-4 } { 3-1 }	1	1	1	1	1	1 2-4
Underwriter's insulation..	1	{ 2-5 or 6 } { 13-1 }	1	1	1	1	1 1
Double weatherproof .....	{ 12-4 } { 13 & 2-4 }	{ 2-5 or 6 } { 13-1 }	{ 12-4 } { 13-1 }	{ 12-8 } { 13-1 }	{ 12-4 } { 13-1 }	1	1 1
Triple weatherproof.....	13-4	{ 13-5 or 6 } { or 8 }	{ 12-4 } { 13-1 }	{ 12-5 } { 13-4 }	{ 12-5 } { 13-4 }	1	1 2-5
Plain rubber.....	{ 13-4 } { 3-1 }	13-5	{ 12-5 } { 13-4 }	13-8	{ 12-5 } { 13-4 }	1	1 2-5
Taped or braided rubber..	13-4	13-5	{ 12-5 } { 13-4 }	13-8	{ 12-5 } { 13-4 }	1	1 2-5
Taped or braided cored rubber.....	13-4	13-5 or 9	{ 12-5 } { 13-4 }	13-8	{ 12-5 } { 13-4 }	1	1 2-5
Gutta percha, armored.....	1	1	1	1	1	1	1 1
Rubber, leaded.....	10	9	1	8	1	1	1 11
Paper, leaded.....	10	9	1	8	1	1	1 11
Fiber, leaded.....	10	9	1	8	1	1	1 11
Any insulation, leaded and asphalted.....	10	9	6	8	6	11	11 10

**Insulation**, in the form of a covering, is required for electrical conductors in all cases with the exception of switchboard bus-bars and connections and wires used on pole lines, and even these are often insulated. It may serve merely to keep the wires from making contact, as is the case with cotton or silk-covered wire. Again, the wire may be covered with a material having a high

specific resistance but being weak mechanically, and this combined with a material serving to give the necessary strength to the insulation. For this purpose yarns are used as the mechanical support, and waxes and asphaltum serve for the insulation proper.

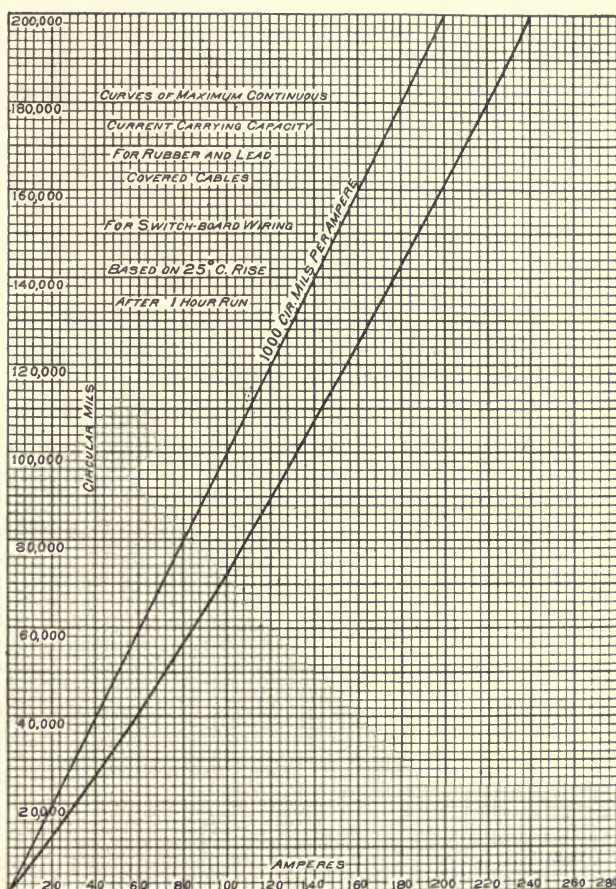

Fig. 1.

**Annunciator** wire is covered with heavy cotton yarn saturated with paraffine. The so-called **Underwriter's** wire is insulated with cotton braid saturated with white paint. Asphaltum or mineral wax is used for insulating **Weatherproof** wire. It may be applied in several ways, the best insulation being made by covering the conductor with a single braiding laid over asphaltum and then passing



the covered wire through the liquid insulation, at the same time applying two cotton braids, and finishing by an external application of asphaltum and polishing. The most complete insulation is made up of a material which gives the most perfect insulation and which is strong enough, mechanically, to withstand pressure and abrasion without additional support.

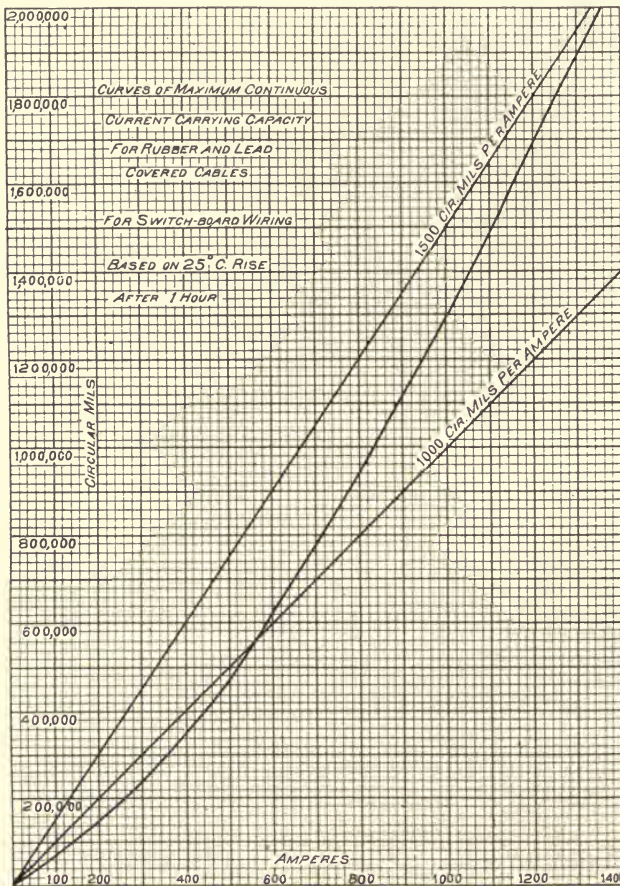

Fig. 1.

**Gutta Percha and India Rubber.** Gutta percha is used for submarine cables, but rubber is the insulating material most used for electrical conductors. Gutta percha cannot be used when exposed to air, as it deteriorates rapidly under such conditions.



Rubber, when used, is vulcanized, and great care is necessary in the process. This vulcanized rubber is usually covered with braid having a polished asphaltum surface. The insulation of high-tension cables will be considered in the topic, "Underground Construction."

### DISTRIBUTION SYSTEMS.

Distribution systems may be divided into *series* systems, *parallel* systems, or combinations, such as *series-parallel* or *parallel-series* systems. Various translating devices may be connected in circuit, changing from one system to the other, and the parallel system may be divided into *single* and *multiple-circuit* systems commonly known as *two-wire* and *three-*, or *five-wire* systems.

**Series Systems** are applied to series arc lighting, series incandescent lighting, and to constant-current motors driving machinery, or generators feeding secondary circuits. They serve for both alternating and direct currents. Fig. 2 shows the arrangement of units in this system.

The current, generated by the dynamo D, passes from the positive brush A (in direct-current systems) through the units L in series to the negative brush B.

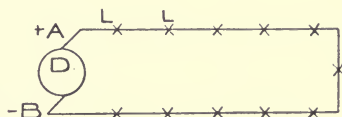

Fig. 2.

For lighting purposes, this current has a constant value and special machines are used for its generation. The voltage at the generator depends on the voltage required by the units and the number of units connected in service. As an example, the voltage allowed for a direct-current open-arc lamp and its connections may be taken as 50 volts. If 40 lamps are burning, the potential generated will be  $50 \times 40 = 2,000$  volts. The number of units is sometimes great enough to raise this potential to 6,000 volts; but by a special arrangement of the Brush arc machine, known as the multiple-circuit arc machine, the potential is so distributed that its maximum value on the line is but 2,000 volts, provided the lamps are equally distributed, while the total electromotive force generated is 6,000 volts, when the machine is fully loaded.

The machine is supplied with three commutators and the lamps connected as shown in Fig. 3, which also shows the distribution of potential.

All calculations for series systems are simple. The drop in voltage is obtained from Ohm's law,  $I = \frac{E}{R}$ . A wire smaller than No. 8 should never be used for line construction, as it would not be strong enough mechanically, even though the drop in voltage with its use should be well within the limit.

The current taken by arc lamps seldom exceeds 10 amperes. For series incandescent lighting, the current may be lower than

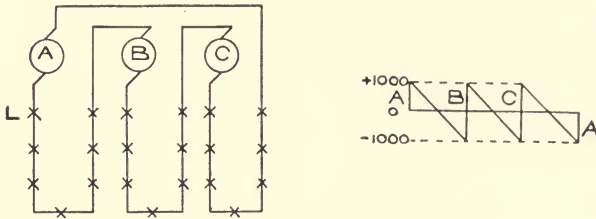

Fig. 3.

this, having a value from 2 to 4 amperes. Special devices are used to prevent the breaking of a single filament from putting out all of the lights in the system and automatic short-circuiting devices are used with series arc lamps for accomplishing the same purpose.

As an example of the calculation of series circuits, required the drop in voltage and loss of energy in a line four miles long and composed of No. 8 wire, when the current flowing in the line is 9.6 amperes. From Table 1 we have a resistance of .0007007 ohm per foot for No. 8 wire at 50° C. This gives a resistance of 3.7 ohms per mile, or a resistance of 14.8 ohms for the circuit. The drop in voltage from Ohm's law equals current times resistance or equals  $9.6 \times 14.8 = 142$  volts. The loss in energy equals the square of the current times the resistance, equals  $9.6^2 \times 14.8 = 1,364$  watts. If the circuit contains 80 lamps, each taking 50 volts, the total voltage of the system is 4,142 volts, and the percentage drop in pressure is  $\frac{142}{4142} = 3.43\%$ .

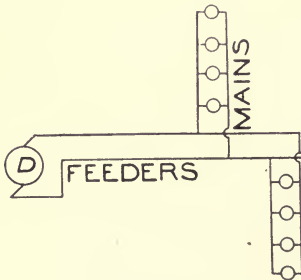

Fig. 4.

**Parallel Systems of Distribution.** In the parallel or "multiple-arc" system of distribution, the lamps or motors are supplied with a constant potential, and the current supplied by the generators is the sum of the currents taken by each translating device. There are several methods of distribution applicable to this system, each one having some characteristic which makes its use desirable for certain installations. The usual arrangement is to run conductors known as "feeders" out from the station, and connected to these feeders are other conductors known as mains, to which, in turn, the receivers or translating devices are connected. Fig. 4 is a diagram of such a "feeder and main" system.

The feeders may be connected at the same ends of the mains, known as parallel feeding; or they may be connected at the opposite ends of the main, giving us the anti-parallel system of feeding. The mains may be of uniform cross-section throughout, or they may change in size so as to keep the current density approximately constant. The above conditions give rise to four possible combinations, namely:

- I. Cylindrical conductors, parallel feeding. Fig. 5.
- II. Tapering conductors, parallel feeding. Fig. 6.
- III. Cylindrical conductors, anti-parallel feeding. Fig. 7.
- IV. Tapering conductors, anti-parallel feeding. Fig. 8.

The regulation of the voltage of a system is of particular importance when incandescent lamps are supplied; and the calculation of the drop in voltage to lamps connected to mains supplied with a constant potential should be considered. Without going into detail as to the methods of derivation, we have the following formulæ which apply to the above combinations when the receivers are uniformly distributed and each taking the same amount of current.

Cylindrical conductors, parallel feeding,

$$D = \frac{RIx}{L} (2L - x) \quad \text{I}$$

Tapering conductors, parallel feeding,

$$D = 2 RIx. \quad \text{II}$$

Cylindrical conductors, anti-parallel feeding,

$$D = \frac{RIx}{L} (L - x) \quad \text{III}$$

Tapering conductors, anti-parallel feeding,

$$D = 0. \quad \text{IV}$$

where  $D$  = difference between potentials applied to different lamps.

$R$  = resistance of conductors per unit length at feeding point. This will be a constant quantity for cylindrical conductors, but will change for tapering conductors, having its minimum value at the feeding point, and its maximum value at the end of the main.

$I$  = current in main at feeding point, or point at which the feeders are connected to the mains. In Figs. 5, 6, 7, and 8 the mains only are shown in detail.

$x$  = distance from feeding point to the particular lamps at which the voltage is being considered.

$L$  = length of main.

For Cases I and II the maximum difference of potential is found where  $x = L$ , that is, at the lamps located at the end of the mains.

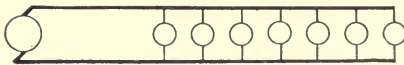

Fig. 5.

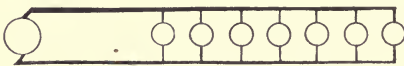

Fig. 6.

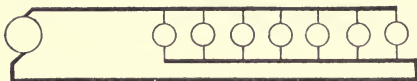

Fig. 7.

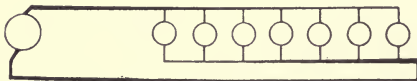

Fig. 8.

For Case III the maximum difference of potential is found where  $x = \frac{L}{2}$ , or at the lamp located at the middle point of the mains.

For Case IV the potential on all of the lamps is the same, but the difference between the voltage on the feeders and the voltage on the lamps is equal to  $RI L$ .

For unequal distribution of receivers and special feeding

points the drop in voltage can be calculated by the aid of Ohm's law, but this calculation becomes quite complicated for extensive systems. It usually is sufficient to keep the *maximum* drop within the desired limits when designing electrical conductors for lighting, being careful not to exceed the safe carrying capacity of the wires.

The drop in voltage on the feeders can be calculated directly from Ohm's law when direct current is used, knowing the current flowing and the dimensions of the conductors used.



Additional formulae are given in "Electric Wiring," which will aid in determining the size of wire to be used for a given installation.

As examples of calculation we have the following:

System consists of 20 lamps, each taking .5 amperes.  $L = 80$  feet.  $R = .01$  ohm per foot at feeding point. Find the maximum difference of potential on the lamps in each of the first three cases.

$$I = 20 \times .5 = 10 \text{ amperes.}$$

$$\text{Case I. } D = \frac{.01 \times 10 \times 80}{80} \times (160 - 80) = 8 \text{ volts.}$$

$$\text{Case II. } D = 2 \times .01 \times 10 \times 80 = 16 \text{ volts.}$$

$$\text{Case III. } D = \frac{.01 \times 10 \times \frac{80}{2}}{80} \times \left(80 - \frac{80}{2}\right) = 2 \text{ volts.}$$

In Case IV the difference in potential applied to the lamps and the potential of the feeders would be  $.01 \times 10 \times 80 = 8$  volts.

Again, with the maximum allowable drop given, the resistance of the wires at the feeding point may be determined. For tapering conductors, the current density is kept approximately constant by using wire of a smaller diameter as the current decreases. Thus supposing, as in the case considered, that the resistance at the feeding point was .01 ohm per foot. At a distance of 40 feet from the feeding point the current would be only  $\frac{1}{2}$  of 10 or 5 amperes and the size of the wire would be one-half as great, giving it a resistance at this point of .02 ohm per foot.

**Feeding Point.** In order to determine the point at which a system of mains should preferably be fed, that is, the point where the feeders are attached to the mains, it is necessary to find the electrical center of gravity of the system. The method employed is similar to that used in determining the best location of a power plant as regards amount of copper required, and consists of separately obtaining the center of gravity of straight sections and then determining the total resultant and point of application of this resultant of the straight sections to locate the best point for feeding. Actual conditions are often such that the system cannot be



fed at a point so determined, but it is well to run the feeders as close to this point as is practical, as less copper is then required for a given drop in potential.

Consider, as an example, a system such as is shown in Fig. 9. The number of lamps and location of the same are shown in this figure. The loads, A B C D, may be considered as concentrated at A', a point 33.8 feet from I and equal to A + B + C + D. This point is obtained as follows:

$$\begin{aligned} Ax &= By. & 10y &= 20x. & x + y &= 400. & x &= 133.3 \text{ feet.} \\ A + B &= 30. \\ Cx' &= Dy'. & 15x' &= 20y'. & x' + y' &= 500. & x' &= 285.7 \text{ feet.} \\ & & C + D &= 35. \\ (A + B)x'' &= (C + D)y''. & x'' + y'' &= 632.4. & x'' &= 340.5 \text{ feet} \\ 30x'' &= 35y''. \end{aligned}$$

$$A + B + C + D = 65$$

A' is 6.2 feet from C or 33.8 feet from I.

E and F may be combined to form a group of 30 lamps and the resultant of E, F, G, and H is 70 lamps located at B', a point 310 feet from J, this point being located in the same manner as A'. Similarly we find the resultant of the loads at A' and B' to be 135 lamps located at C', a point 331.1 feet from I, and the proper feeding point for the system.

$$A' = 65 \text{ lights, } 33.8 \text{ feet from I.}$$

$$B' = 70 \text{ lights, } 310 \text{ feet from J.}$$

$$\text{Distance IJ} = 360 \text{ feet.}$$

$$\text{Distance from A' to B'} = 360 + 310 + 33.8 = 703.8 \text{ feet.}$$

$$65x = 70y.$$

$$x + y = 703.8 \text{ feet.}$$

$$x = 364.9 \text{ feet.}$$

$$364.9 - 33.8 = 331.1 \text{ feet.}$$

The above is a simple definite case. Should the load be variable, the proper feeding point will change with the load, and, in extensive systems, the location of this point can be obtained approximately only. The same method of calculation is employed in locating the points from which sub-feeders are run out from the terminals of the main feeders as is the case in large systems,

the voltage being maintained constant at the point where the sub-feeders are connected to the feeders.

Good practice shows the drop in potential to be within the following limits:

From feeding points (points where sub-feeders or mains are attached) to lamps.....	5	per cent.
Loss in sub-feeders .....	3	"
Loss in mains .....	1.5	"
Loss in service wires .....	0.5	"

The actual **variation** in voltage should not exceed 3%.

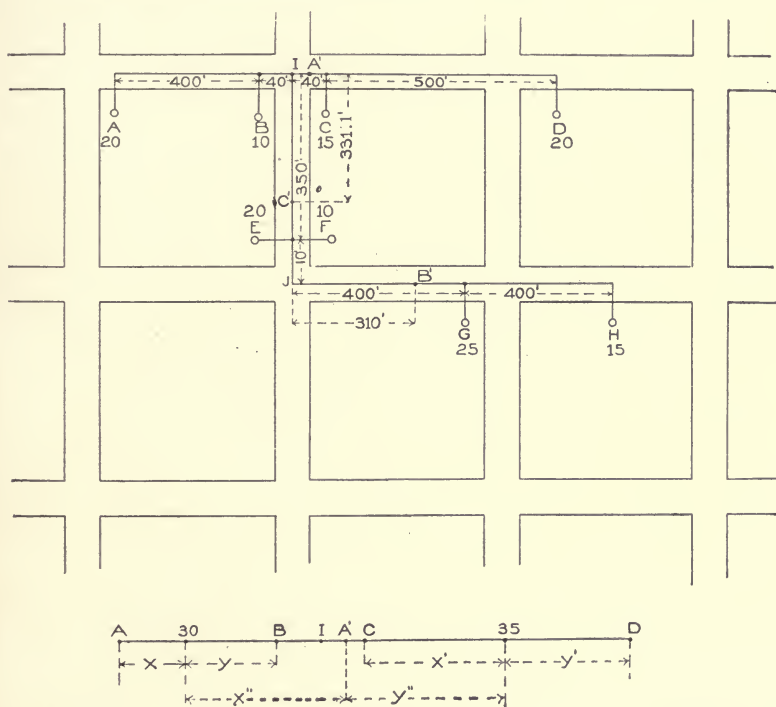

Fig. 9.

In **Series-Multiple and Multiple-Series Systems**, groups of units, connected in multiple, are arranged in series in the circuit, or groups of units are connected in series and those, in turn, connected in multiple, respectively. The application of such systems is limited. They are used to some extent in street-lighting when incandescent lamps are used.

MULTIPLE-WIRE SYSTEMS.

**The Three-Wire System.** We have seen that in any system of conductors the power lost is equal to  $I^2R$ . For a given amount of power transmitted ( $IE$ ) the current varies inversely with the voltage and consequently the amount of power lost, which is directly proportional to the square of the current, is inversely proportional to the square of the voltage. Hence, for the same loss of power and the same percentage drop in voltage, doubling the voltage of the system would allow the resistance of the conductors to be made four times as great, and wire of one-fourth the cross-

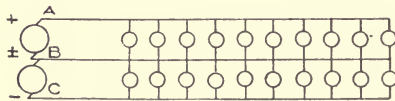

Fig. 10.

section or one-fourth the amount of copper would be required. The voltage for which incandescent lamps, having a reasonable efficiency, can be economically manu-

factured is limited to 220, while the majority of them are made for 110. In order to increase the voltage on the system, a special connection of such lamps is necessary. The three-wire and five-wire systems are adopted for the purpose of increasing this voltage. Fig. 10 shows a diagram of a three-wire system. Consider the conductor B removed, and we have a series-multiple system with two lamps in series. This arrangement does not give independent control of individual lamps, and the third wire is introduced to take care of any unbalancing of the number of lamps or units connected on either side of the system, and to allow more freedom in the location of the lights. The current

flowing in the conductor B, known as the neutral conductor, depends on the difference of the currents required by the units on the two sides of the system.

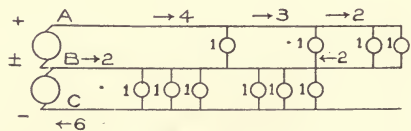

Fig. 11.

Fig. 11 shows a system in which the loads on the two sides are unequal, an unbalanced system, with the value of the current in the neutral wire at different points. Each unit is here assumed to take one ampere.

As stated above, were no neutral wire required, the amount of copper necessary for a system with the lamps connected, two in series, for the same percentage drop in voltage would be one-fourth the amount necessary for the parallel connection. This may be shown as follows: The current in the wire in the first case is one-half as great, so that the voltage drop would be divided by two for the same size wire.

The voltage on the system is twice as great, so that, with the same *percentage* regulation,

the actual voltage drop would be doubled. Consequently wire of one-fourth the cross-section and weight may be used.

If the neutral wire is made one-half the size of the outside conductor, as is usually the case in feeders, the amount of copper required is  $\frac{5}{16}$  of that necessary for the two-wire system.

For mains it is customary to make all three conductors the same size, increasing the amount of copper to  $\frac{3}{2}$  of that required for a two-wire system.

For a five-wire system with all conductors the same size, the weight of copper necessary is .156 times that for a two-wire system.

Multiple-wire systems have no advantage other than saving of copper, except when used for multiple-voltage systems, while among their disadvantages may be mentioned:

Complication of generating apparatus.

Complication of instruments and wiring.

Liability to variation in voltage, due to unbalancing of load.

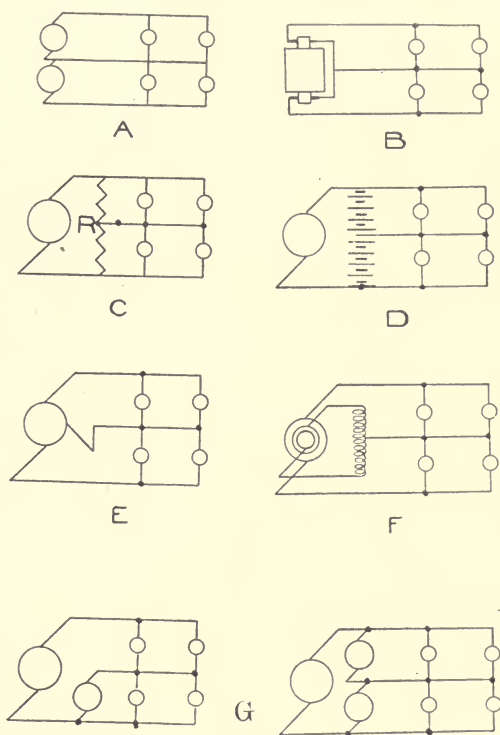

Fig. 12.

Fig. 12 shows some of the methods employed in generating current for a three-wire system.

- A. Two dynamos connected in series, the usual method
- B. A double dynamo.
- C. Bridge arrangement, using a resistance  $R$  with the neutral connection arranged so as to change the value of resistance in either side of the system. Has the disadvantage of continuous loss of energy in  $R$ .
- D. Storage battery connected across the line with neutral connected at middle point.
- E. Special dynamo supplied with three brushes.
- F. Special machine having collector rings, across which is connected an impedance coil, the neutral wire being connected to the middle point of this coil.
- G. Compensators or motor-generator set used in connection with generator. The motor-generator set is known as a balancer set.

Compensators are usually wound for about 10% of the capacity of the machine with which they are used. In the motor-generator set, one side becomes a motor or generator depending on whether the load on that side is less or greater than the load on the opposite side.

**Voltage Regulation of Parallel Systems.** It is customary to keep the voltage on the mains constant, or as nearly so as possible, at the point where the feeders are attached. Where but one set of feeders is run out from the station, this may be readily accomplished by the use of over-compounded dynamos, adjusted to give an increase of voltage equal to the drop in the feeders at different loads. Again, the field of a shunt-wound generator may be controlled by hand, the pressure at the feeding points being indicated by a voltmeter connected to pilot wires running from the feeding point back to the station.

When the system is more extensive, separate regulation of different feeders is necessary. A variable resistance may be placed in series with separate feeders, but this is undesirable on account of a constant loss of energy. Feeders may be connected in along a system of mains and one or more of these switched in or out of service as the load changes. Bus-bars giving different voltages may be arranged so that the feeders can be changed to a higher voltage bar as the load increases. Boosters—series dynamos—may be connected in series with separate feeders and these may be arranged to regulate the voltage automatically. The use of boosters is



not to be recommended except for a few very long feeders, and then the total capacity of boosters should equal but a small percentage of the station output if the efficiency of the system as a whole is to remain high. Fig. 13 is a diagram of a system using different methods of voltage regulation.

**Alternating-Current Systems of Distribution** may be classified in a manner similar to direct-current systems, that is, as series and parallel systems; but in addition to these we have a classification depending on the number of phases used, such as *single-phase*, *quarter- or two-phase* and *three-phase systems*.

**The Series System** may consist of a simple series circuit fed by a constant-current generator, or it may be fed by a constant-

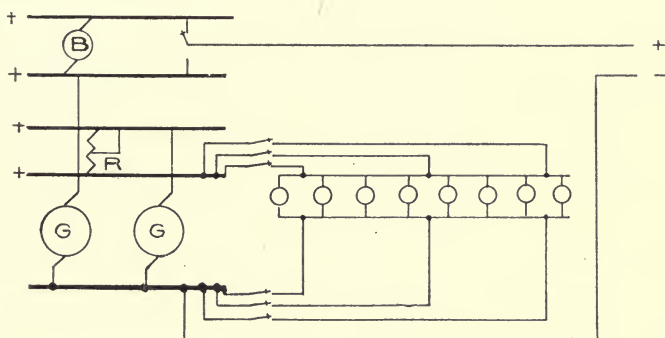

Fig. 13.

current transformer, the primary of which is supplied with a constant potential, the secondary furnishing a constant current. For a description of such a transformer, see "Electric Lighting". Again, the current may be maintained constant by means of a constant-current regulator, such as is described in "Electric Lighting". Constant-current alternators are seldom used, the two latter forms of regulation being applied to most series installations. The principal application of series alternating-current systems is to street-lighting. Parallel-series alternating-current systems are sometimes used for street-lighting with incandescent lamps.

**Parallel Systems**, using alternating current are also analogous to parallel systems using direct current, though the receivers, especially if lamps, are seldom connected directly to the leads coming from the station, but are fed from the secondaries of constant-

potential transformers, which are connected to the lines in parallel, and step down the voltage. The readiness with which the voltage of such systems may be changed by means of suitable transformers is the chief advantage of the single-phase systems. The voltage may be generated at, or transformed up to, a high value at the station, transmitted over a considerable distance over small conductors with a small loss of energy, and then transformed to the desired value for the connected units. Transformers may be readily constructed to furnish voltage for a three-wire secondary distribution. Fig. 14 is a diagram of a single-phase system supplying power to both two-wire and three-wire systems. Two separate transformers are used for obtaining the three-wire system, in one case, and a transformer, supplied with a tap connected to the middle point of the secondary, is used in the other case.

The regulation of voltage for alternating-current systems may be accomplished, as in direct-current installations, by means of compounding ("composite-wound alternators"), hand regulation, or resistance or reactance connected in series with the feeders. In addition, the feeders may be controlled by means of special regulators such as the Stillwell Regulator, or the "C R" Regulator, which consist of transformers with the primary coil connected across the line and the secondary in series with the line, and so arranged that the number of turns in one or both windings may be varied; other forms of regulators are the magnetic regulator and the induction regulator.

**Polyphase Systems.** Polyphase systems of distribution are used where motors are to be run from the circuits; also for long-distance transmission lines partly on account of the saving in copper. Polyphase generators may be constructed more cheaply, for a given output, than single-phase machines because of a better utilization of the winding space on the armature; while single-phase motors, except in small sizes, or series motors as applied to railway work, are not entirely satisfactory. Two-phase and three-phase systems are the only ones that are in common use for power transmission, three phases being used for long-distance transmission lines. Six phases are used for rotary converters only, the capacity of the machines being greatly increased when connected six-phase.

The amount of copper required for the different systems, assuming the weight of copper for a single phase two-wire system to be 100%, is as follows:

Single-phase two-wire systems.....	100 per cent
"    "    three-wire    "    (Neutral wire same size as outside wires).....	37.5 "
Two-phase four-wire system .....	100 "
"    "    three-wire    "    .....	72.9 "
Three-phase three-wire system.....	75 "
"    "    four-wire    "    .....	33.3 "

This assumes the voltage on the receivers to be the same in every case, the maximum voltage having different values, depending on the system used. The three-phase three-wire system is preferable to the two-phase three-wire system for most purposes. In the three-

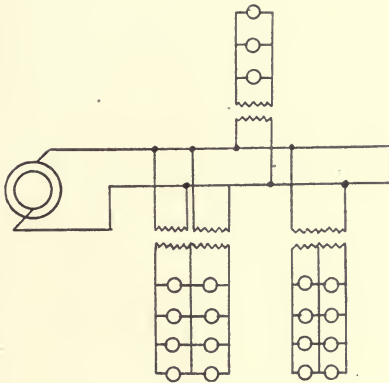

Fig. 14.

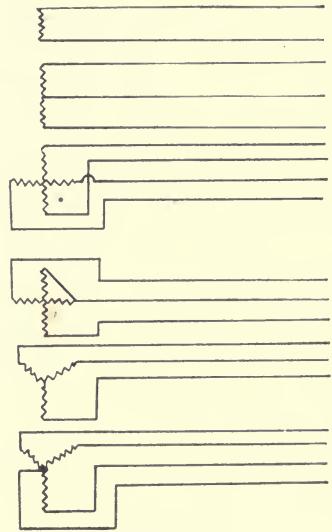

Fig. 15.

phase four-wire system the maximum voltage is  $\sqrt{3}$  times the voltage on the receivers. Were the same maximum voltage allowable as in the three-phase three-wire system, the amount of copper for the three-phase four-wire system would be  $\frac{4}{3}$  that required for the three-phase three-wire system. Fig. 15 shows, diagrammatically, the connections of the different systems.

As an example of the way in which the relative amounts of copper are calculated, take the three-phase three-wire system. Assume the amount of power transmitted to be P and the percent-

age loss of energy to be  $\rho$ . Let  $E$  = the voltage on the receiver,  $I$  = the current flowing in a single conductor, single-phase system, and  $I'$  = current in a single conductor, three-phase system. We have for the single-phase two-wire system,

$$P = IE,$$

for the three-phase three-wire system,

$$\begin{aligned} P &= \sqrt{3} I'E \\ IE &= \sqrt{3} I'E \\ I' &= \frac{I}{\sqrt{3}} \end{aligned}$$

The loss in energy in the two-wire system =  $\rho P = 2 I^2 R$ , when  $R$  = resistance of one conductor. The loss in energy in the three-phase system =  $\rho P = 3 I'^2 R'$ .

Substituting  $\frac{I}{\sqrt{3}}$  for  $I'$ , we have

$$2 I^2 R = \frac{3 I'^2 R'}{3} \text{ or } 2 R = R'.$$

The amount of copper is inversely proportional to the resistance of the conductor, so that if  $W$  = weight of one conductor for single-phase system and  $W'$  = weight of one conductor for three-phase system,  $W = 2 W'$ .

Two conductors are required in the first case =  $2 W$ .

Three conductors are required in the second case =  $3 W'$ .

$$3 W' = \frac{3}{2} W.$$

$$2 W = 2 W.$$

$$\frac{3 W'}{2 W} = \frac{\frac{3}{2} W}{2 W} = \frac{3}{4} = 75\%.$$

### TRANSMISSION LINES.

**Capacity.** Conductors used for the transmission of power form, with their metallic shields, with the ground, or with neighboring conductors, condensers, which, when the line is long, have an appreciable capacity. The capacity of circuits is quite readily calculated, the following formula applying to individual cases.

TABLE IV.

Capacity in Micro-Farads Per Mile of Circuit for Three-Phase System.

Size B. & S.	Diam. in inch.	Distance A in inches.	Capacity C in M. F.	Size B. & S.	Diam. in inch.	Distance A in inches.	Capacity C in M. F.
0000	.46	12	.0226	4	.204	12	.01874
		18	.0204			18	.01726
		24	.01922			24	.01636
		48	.01474			48	.01452
000	.41	12	.0218	5	.182	12	.01830
		18	.01992			18	.01690
		24	.01876			24	.01602
		48	.01638			48	.01426
00	.365	12	.0124	6	.162	12	.01788
		18	.01946			18	.01654
		24	.01832			24	.01560
		48	.01604			48	.0140
0	.325	12	.02078	7	.144	12	.01746
		18	.01898			18	.01618
		24	.01642			24	.01538
		48	.01570			48	.01374
1	.289	12	.02022	8	.128	12	.01708
		18	.01952			18	.01586
		24	.01748			24	.01508
		48	.0154			48	.01350
2	.258	12	.01972	9	.114	12	.01660
		18	.01818			18	.01552
		24	.01710			24	.01478
		48	.01510			48	.01326
3	.229	12	.01938	10	.102	12	.01636
		18	.01766			18	.01522
		24	.01672			24	.01452
		48	.01480			48	.01304

$$C = \frac{38.83 k 10^{-3}}{\log \frac{D}{d}} \text{ per mile. } \quad \text{Insulated cable with lead sheath.}$$

$$C = \frac{38.83 \times 10^{-3}}{\log \frac{4h}{d}} \text{ per mile. } \quad \text{Single conductor with earth return.}$$

$$C = \frac{19.42 \times 10^{-3}}{\log \frac{2A}{d}} \text{ per mile of circuit. } \quad \text{Parallel conductors forming a metallic circuit.}$$



$C$  = Capacity in micro-farads. (Divide by 1,000,000 to give capacity in farads.)

$k$  = specific inductive capacity of insulating material = 1 for air = 2.25 to 3.7 for rubber.

$D$  = inside diameter of lead sheath.

$d$  = diameter of conductor.

$h$  = distance of conductors above ground.

$A$  = distance between wires.

Common logarithms apply to these formulæ and  $C$  for a metallic circuit is the capacity between wires.

TABLE V.  
Inductance Per Mile of Three-Phase Circuit.

Size B. & S.	Diameter in inch.	Distance $d$ in inches.	Self-inductance $L$ henrys.	Size B. & S.	Diameter in inch.	Distance $d$ in inches.	Self-inductance $L$ henrys.
0000	.46	12	.00234	4	.204	12	.00280
		18	.00256			18	.00300
		24	.00270			24	.00315
		48	.00312			48	.00358
000	.41	12	.00241	5	.182	12	.00286
		18	.00262			18	.00307
		24	.00277			24	.00323
		48	.00318			48	.00356
00	.365	12	.00248	6	.162	12	.00291
		18	.00269			18	.00313
		24	.00285			24	.00329
		48	.00330			48	.00369
0	.325	12	.00254	7	.144	12	.00298
		18	.00276			18	.00310
		24	.00293			24	.00336
		48	.00331			48	.00377
1	.289	12	.00260	8	.128	12	.00303
		18	.00281			18	.00325
		24	.00308			24	.00341
		48	.00338			48	.00384
2	.258	12	.00267	9	.114	12	.00310
		18	.00288			18	.00332
		24	.00304			24	.00348
		48	.00314			48	.00389
3	.229	12	.00274	10	.102	12	.00318
		18	.00294			18	.00340
		24	.00310			24	.00355
		48	.00351			48	.00396

If the capacity be taken between one wire and the neutral point of a system, or the point of zero potential, the capacity is given as:

$$C \text{ (in micro-farads)} = \frac{.0776}{2 \log \frac{2A}{d}} \text{ per mile of circuit.}$$

Table IV gives the capacity, to the neutral point, of different size wire used for three-phase transmission lines.

The effect of this capacity is to cause a charging current, 90° in advance of the impressed pressure, to flow in the circuit, and the regulation of the system is affected by this charging current as will be seen later. Capacity may be reduced by increasing the distance between conductors or in lead-sheathed cables, by using an insulating material having a low specific inductive capacity, such as paper.

**Inductance.** The self-inductance of lines is very readily calculated. Following is a formula applicable to copper or aluminum conductors:

$$L = .000558 \left[ 2.303 \log \left( \frac{2A}{d} \right) + .25 \right] \text{ per mile of circuit when}$$

$L =$  inductance of a loop of a three phase circuit in henrys. The inductance of a complete circuit, single phase, is equal to the above value multiplied by  $2 \div \sqrt{3}$ .

Self-inductance is reduced by decreasing the distance between wires and it disappears entirely in concentric conductors. Subdividing the conductors decreases the drop in voltage due to self-inductance but it complicates the wiring. Circuits formed of conductors twisted together have very little inductance. When alternating-current wires are run in iron pipes, both wires of the circuit must be run in the same pipe, inasmuch as the self-inductance depends on the number of magnetic lines of force passing between the conductors or threading the circuit, and this number will be increased when iron is present between the conductors.

The effect of self-inductance in a circuit is to cause the current to lag behind the impressed voltage and it also increases the impedance of the circuit.

The effect of self-inductance may be neutralized by capacity or *vice-versa*. The relative value of the two must be as follows:

$C = \frac{1}{(2\pi f)^2 L}$  when C and L are in farads and henrys respectively, and  $f$  is the frequency of the system.

**Mutual-Inductance.** By mutual-inductance is meant the inductive effect one circuit has on another separate circuit, generally a parallel circuit in power transmission. An alternating current flowing in one circuit sets up an electromotive force in a parallel circuit which is opposite in direction to the E.M.F. impressed on the first circuit, and is proportional to the number of the lines of force set up by the first circuit which thread the second circuit.

•A  
•D

•C  
•B

Fig. 16.

The effects of mutual inductance may be reduced by increasing the distance between the circuits, the distance between wires of a circuit remaining the same. This is impractical beyond a

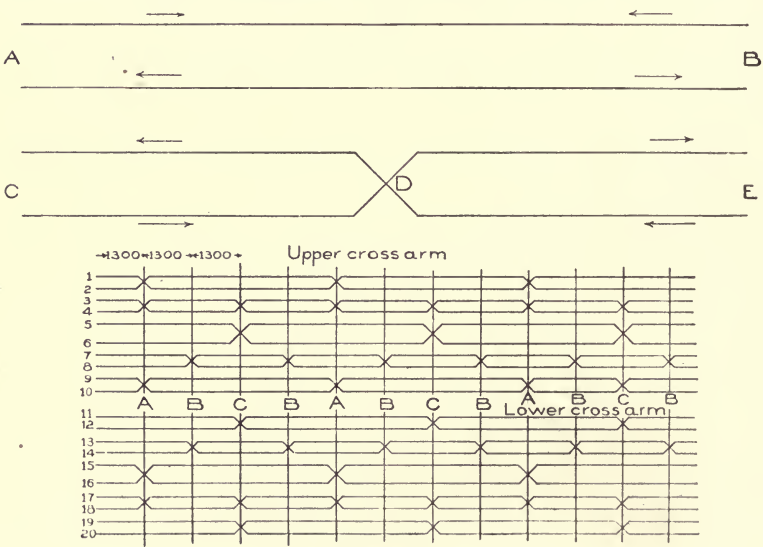

Fig. 17:

certain extent, if the circuits are to be run on the same pole line, so that a special arrangement of the conductors is necessary.

Figs. 16 and 17 show such special arrangements. In Fig. 16 AB forms the wires of one circuit and CD the wires of the other

circuit. Lines of force set up by the circuit AB do not thread the circuit CD, provided A B C and D are arranged at the corners of a square so that there is no effect on the circuit CD. In Fig. 17 assume an E.M.F. to be set up in the portion of the circuit CD in the direction of the arrows. The E.M.F. in the section DE will then be in the direction of the arrows shown and the effects on the circuit AB will be neutralized, provided the transposition, as the crossing of the conductors is called, is made at the middle of the line. Such transpositions are made at frequent intervals on transmission lines to do away with the effects of mutual inductance which, at times, might be considerable. When several circuits are run on the same pole line, these transpositions must be made in such a manner that each circuit is transposed in its relation to the other circuits. Thus in Fig. 17 is also shown the transposition of the circuits of a line composed of ten two-wire circuits.

#### CALCULATION OF ALTERNATING-CURRENT LINES.

In dealing with alternating currents, Ohm's law can be applied only when all of the effects of inductance and capacity have been eliminated, and, since this can seldom be accomplished, a new formula must be used which takes such capacity and inductance effects into account. Not only the inductance or capacity of the line itself must be considered, but the nature of the receiver must be taken into account as well, when the regulation of the system as a whole is being considered. The following quantities must be known in the complete solution of problems relating to alternating-current systems.

1. Frequency of the current used.
2. Self-induction and capacity of the receivers.
3. Self-induction and capacity of the lines.
4. Voltage of, and current flowing in, the lines.
5. Resistance of the various parts.

Following is a set of formulæ and an appropriate table for calculating transmission lines proper when using direct or alternating current and for frequencies varying from 25 to 125, and for single and polyphase currents. This table is issued by the General Electric Company.

## GENERAL WIRING FORMULA.

$$\text{Area of conductor, Circular Mils} = \frac{D \times W \times C^2}{p \times E^2}$$

$$\text{Current in main conductors} = \frac{W \times T}{E}$$

W = Total watts *delivered*.

D = Distance of transmission (one way) in feet.

p = Loss in line in per cent of power *delivered*, that is, of W.

E = Voltage between main conductors at *receiving* or *consumer's* end of circuit.

For continuous current C' = 2,160, T = 1, B = 1, and A = 6.04.

$$\text{Volts loss in lines} = \frac{p \times E \times B}{100}$$

$$\text{Lbs. copper} = \frac{D^2 \times W \times C' \times A}{p \times E^2 \times 1,000,000}$$

The following formula will also be found convenient for calculating the copper required for long-distance three-phase transmission circuits:

$$\text{Lbs. Copper} = \frac{M^2 \times \text{K.W.} \times 300,000,000}{p \times E^2}$$

M is the distance of transmission in miles, K.W. the power delivered in kilowatts, and the power factor is assumed to be approximately 95%.

## APPLICATION OF FORMULÆ.

“The value of C' for any particular power factor is obtained by dividing 2,160, the value for continuous current, by the square of that power factor for single-phase, by twice the square of that power factor for three-wire three-phase, or four-wire two-phase. The value of B depends on the size of wire, frequency, and power factor. It is equal to 1 for continuous current, and for alternating current with 100 per cent power factor and sizes of wire given in the following table of wiring constants.

“The figures given are for wires 18 inches apart, and are sufficiently accurate for all practical purposes provided the displacement in phase between current and E.M.F. at the receiving end is not



TABLE VI.

System.	Values of A.	Values of C.				
		Per Cent Power Factor.				
		100	95	90	85	80
Single-phase.....	6.04	2,160	2,400	2,660	3,000	3,380
Two-phase (four-wire)....	12.08	1,080	1,200	1,330	1,500	1,690
Three-phase (three-wire)...	9.06	1,080	1,200	1,330	1,500	1,690

System.	Values of T.				
	Per Cent Power Factor.				
	100	95	90	85	80
Single-phase.....	1.00	1.05	1.11	1.17	1.25
Two-phase (four-wire).....	.50	.53	.55	.59	.62
Three-phase (three-wire).....	.58	.61	.64	.68	.72

No. of Wire, B. & S. Gauge.	VALUES OF B.							
	60 Cycles.				125 Cycles.			
	Per Cent Power Factor.				Per Cent Power Factor.			
	95	90	85	80	95	90	85	80
0000	1.62	1.84	1.99	2.09	2.35	2.86	3.24	3.49
000	1.49	1.66	1.77	1.95	2.08	2.48	2.77	2.94
00	1.34	1.52	1.60	1.66	1.86	2.18	2.40	2.57
0	1.31	1.40	1.46	1.49	1.71	1.96	2.13	2.25
1	1.24	1.30	1.34	1.36	1.56	1.75	1.88	1.97
2	1.18	1.23	1.25	1.26	1.45	1.60	1.70	1.77
3	1.14	1.17	1.18	1.17	1.35	1.46	1.53	1.57
4	1.11	1.12	1.11	1.10	1.27	1.35	1.40	1.43
5	1.08	1.08	1.06	1.04	1.21	1.27	1.30	1.31
6	1.05	1.04	1.02	1.00	1.16	1.20	1.21	1.21
7	1.03	1.02	1.00	1.00	1.12	1.14	1.14	1.13
8	1.02	1.00	1.00	1.00	1.09	1.10	1.09	1.07
9	1.00	1.00	1.00	1.00	1.06	1.06	1.04	1.02
10	1.00	1.00	1.00	1.00	1.04	1.03	1.00	1.00

No. of Wire B. & S. Gauge.	Area of Wire Circular Mills	Weight of Bare Wire Per 1,000 ft.-lbs.	Resistance of Wire Per 1,000 feet at 35° C. Ohms.	Values of B.											
				25 Cycles.						40 Cycles.					
				Per Cent Power Factor.			Per Cent Power Factor.			Per Cent Power Factor.			Per Cent Power Factor.		
0000	212000	641	.0499	95	90	85	80	95	90	85	80	95	90	85	80
0000	168000	509	.0628	1.23	1.29	1.33	1.34	1.52	1.53	1.61	1.67	1.40	1.41	1.48	1.51
00	133000	403	.0794	1.18	1.22	1.24	1.24	1.25	1.32	1.35	1.37	1.19	1.24	1.26	1.26
0	106000	320	.0997	1.14	1.16	1.16	1.16	1.09	1.17	1.18	1.17	1.14	1.17	1.18	1.17
1	83500	253	.126	1.10	1.11	1.10	1.09	1.11	1.12	1.12	1.12	1.11	1.12	1.12	1.10
2	66600	202	.159	1.07	1.07	1.05	1.03	1.03	1.07	1.07	1.05	1.07	1.08	1.07	1.05
3	52400	159	.202	1.05	1.04	1.02	1.00	1.00	1.06	1.06	1.03	1.05	1.06	1.03	1.00
4	41600	126	.254	1.03	1.02	1.00	1.00	1.00	1.01	1.01	1.00	1.00	1.01	1.00	1.00
5	33100	100	.319	1.02	1.00	1.00	1.00	1.00	1.00	1.00	1.00	1.00	1.00	1.00	1.00
6	26200	79.5	.403	1.00	1.00	1.00	1.00	1.00	1.00	1.00	1.00	1.00	1.00	1.00	1.00
7	20700	62.8	.510	1.00	1.00	1.00	1.00	1.00	1.00	1.00	1.00	1.00	1.00	1.00	1.00
8	16600	50.4	.635	1.00	1.00	1.00	1.00	1.00	1.00	1.00	1.00	1.00	1.00	1.00	1.00
9	13000	39.4	.813	1.00	1.00	1.00	1.00	1.00	1.00	1.00	1.00	1.00	1.00	1.00	1.00
10	10400	31.5	1.01	1.00	1.00	1.00	1.00	1.00	1.00	1.00	1.00	1.00	1.00	1.00	1.00

very much greater than that at the generator; in other words, provided that the reactance of the line is not excessive or the line loss unusually high. For example, the constants should not be applied at 125 cycles if the largest conductors are used and the loss 20% or more of the power delivered. At lower frequencies, however, the constants are reasonably correct even under such extreme conditions. They represent about the true values at 10% line loss, are close enough at all losses less than 10%, and often, at least for frequencies up to 40 cycles, close enough for even much larger losses. Where the conductors of a circuit are nearer each other than 18 inches, the volts loss will be less than given by

the formulæ, and if close together, as with multiple-conductor cable, the loss will be only that due to resistance.

“The value of  $T$  depends on the system and power factor. It is equal to 1 for continuous current and for single-phase current of 100 per cent power factor. The value of  $A$  and the weights of the wires in the table are based on .00000302 pound as the weight of a foot of copper wire of one circular mil area.

“In using the above formulæ and constants, it should be particularly observed that  $p$  stands for the per cent loss in the line of the *delivered power*, not for the per cent loss in the line of the power at the generator; and that  $E$  is the potential at the delivery end of the line and not at the generator.

“When the power factor cannot be more accurately determined, it may be assumed to be as follows for any alternating system operating under average conditions: Incandescent lighting and synchronous motors, 95%; lighting and induction motors together, 85%; induction motors alone, 80%.

“In continuous-current three-wire systems, the neutral wire for feeders should be made of one-third the section obtained by the formulæ for either of the outside wires. In both continuous and alternating-current systems, the neutral conductor for secondary mains and house wiring should be taken as large as the other conductors.

“The three wires of a three-phase circuit and the four wires of a two-phase circuit should all be made the same size, and each conductor should be of the cross-section given by the first formula”.

Numerical examples of the application of this table, as well as of other formulæ, are given later.

A better idea of the way in which the different quantities involved affect the regulation of an alternating-current line may be obtained from graphical representation or from formulæ which are not so empirical. Before taking up other methods of calculation, however, let us consider the meaning of power factor.

By **power factor** we mean the cosine of the angle by which the current lags behind or leads the electromotive force producing that current. It is the factor by which the apparent watts (volts times amperes) must be multiplied to give true power. The formula for power in a single-phase circuit is then,

Power =  $IE \cos \theta$  when  $\theta$  is the lag or lead angle; and for three-phase circuits,

Power =  $IE \cos \theta \sqrt{3}$  when  $I$  is the current flowing in a single conductor.

For two-phase circuits, balanced load, this becomes,

Power =  $2 IE \cos \theta$ ; and,

Power =  $2 \sqrt{3} IE \cos \theta$ , for six-phase circuits.

For single and three-phase circuits  $E$  is the voltage between lines. For two-phase circuits it is the voltage across either phase, and for six-phase circuits it is the voltage across one phase of what corresponds to a three-phase connection.

Considering the formula for single phase, we find that the current flowing in the line may be taken as made up of two components, one in phase with the voltage and one  $90^\circ$  out of phase, lagging, or leading, depending on conditions. In Fig. 18 let  $OE$

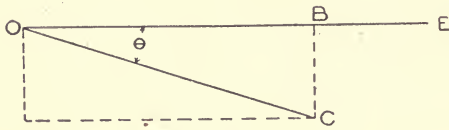

Fig. 18.

equal the impressed pressure and  $OC$  the current flowing.  $\theta =$  angle of lag. The current  $OC$  may be resolved into two components, one in phase with  $OE = OB$ , and one  $90$  degrees behind  $OE = BC$ .

$OB = OC \cos \theta$  and is known as the active component of the current.

$BC = OC \sin \theta$  and is known as the wattless component of the current.

The capacity and inductance are distributed throughout the line, that is, the line may be considered as made up of tiny con-

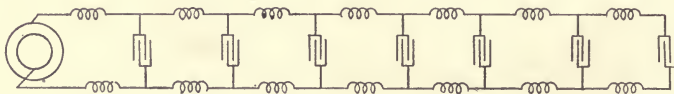

Fig. 19.

densers and reactance coils, connected at short intervals as shown in Fig. 19. Considering the inductance and capacity as distributed in this manner, the regulation of a system may be calculated, but the process is very difficult, and simpler methods, which give very close results, have been adopted for practical work. Probably the

methods presented by Perrine and Baum are as simple as any except those based on purely empirical formulæ.

Tables giving the capacity and inductance of lines, together with the formulæ for the calculation of these quantities, have already been given. It has also been stated that the effect of the capacity of a line is to cause a charging current to flow in the line, this current being  $90^\circ$  in advance of the impressed voltage. The value of this charging current is:

$$\text{Charging current per wire} = \frac{E \times C \times 2 \pi \times f}{2 \times 10^6}, \text{ single-phase.}$$

$C$  = capacity in micro-farads of one wire to neutral point.

$f$  = frequency of the circuit.

$E$  = voltage between wires.

Charging current, three-phase, =  $\frac{2}{\sqrt{3}}$  or  $1.155 \times$  charging current, single-phase.

Since the voltage across the lines is not the same all along the line, the value of the charging current will not be the same, but the error introduced by assuming it to be constant is not great. For our calculation, then, we assume that the charging current in an open-circuited line is constant throughout its length, and also that the capacity of the line may be taken as concentrated at the center of the line.



Fig. 20.

Consider a single-phase line such as is shown diagrammatically in Fig. 20.

Let  $E_0$  = the voltage at the generator end of the line.

$E$  = the voltage at the receiver.

$L$  = self induction of the line.

$I_c$  = charging current per wire.

$I$  = current flowing in the line due to the load on the line.



$\theta$  = angle by which the load current differs from the impressed voltage.

$R$  = resistance of the line.

$e$  = drop in voltage in the line.

$\omega = 2 \pi f$ .

$+j$  is a symbol indicating that the current is  $90^\circ$  in advance of the pressure.

$-j$  indicates that the current is  $90^\circ$  behind the pressure.

The expression,  $\sqrt{R^2 + (2 \pi f L)^2} = \sqrt{R^2 + \omega^2 L^2}$  may be represented by  $R + jL\omega$ , the factor  $+j$  indicating that the square root of the sum of the squares of these two quantities must be taken to obtain the numerical result. The quantity  $j^2$  may be considered as  $-1$ .

Taking the capacity of the line and considering it as a condenser located at the middle of the line, we may assume the charging current as flowing over only one-half of the line, or one-half the charging current may be considered as flowing over all of the line.

The impedance of the line is equal to  $\sqrt{R^2 + \omega^2 L^2} = R + jL\omega$ .

The power factor of the load =  $\cos \theta$ .

The active component of the current is  $I \cos \theta$ .

The wattless component of the current is  $-jI \sin \theta$  ( $-j$  indicating that the current lags  $90^\circ$  behind the pressure).

The charging current may be represented by  $+j \frac{I_c}{2}$ .

Then the drop due to the active component of the load is

$$I \cos \theta (R + jL\omega).$$

The drop due to the wattless component of the load is

$$-jI \sin \theta (R + jL\omega).$$

The drop due to the charging current is  $+j \frac{I_c}{2} (R + jL\omega)$

The total drop is equal to the sum of these three values =  $e$ , so that,

$$\begin{aligned} E_o = E + e &= I \cos \theta (R + jL\omega) - jI \sin \theta (R + jL\omega) \\ &+ j \frac{I_c}{2} (R + jL\omega) \end{aligned}$$

Expanding this and substituting  $-1$  for  $j^2$  we have,

$$E_o = E + I \cos \theta R + jI \cos \theta L\omega - jI \sin \theta R + I \sin \theta L\omega \\ + j \frac{I_c}{2} R - \frac{I_c}{2} L\omega.$$

Referring to Fig. 21 we have these various values plotted graphically.

$$oa = E, \quad ab = -j \frac{I_c R}{2}, \quad bc = -\frac{I_c L\omega}{2}$$

$$cd = + I \cos \theta R, \quad de = + jI \cos \theta L\omega,$$

$$ef = -jIR \sin \theta, \quad fg = + IL\omega \sin \theta,$$

$$og = E_o.$$

$ab$  is plotted  $90^\circ$  in advance of  $oa$  on account of the symbol  $+j$ .

$bc$  is plotted in the opposite direction from  $oa$  on account of the negative sign.

$ef$  is plotted downward on account of the symbol  $-j$ .

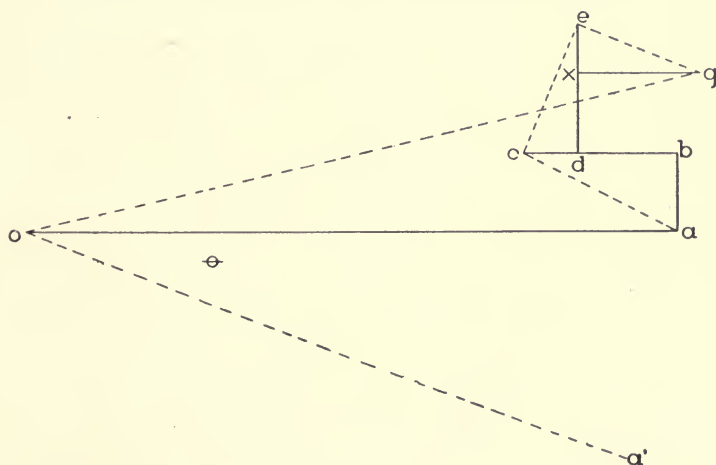

Fig. 21.

If we let  $oa'$ , Fig. 21, represent the current vector, then  $\theta =$  angle of lag, and  $eg$  which equals  $IR$  is plotted parallel to  $oa'$  and  $ce = IL\omega$  is plotted perpendicular to  $oa'$ .

It is seen from this that the charging current tends to produce a rise in E.M.F. instead of a drop in pressure.

The above takes into account only the constants of the line. In order to determine the regulation of a complete system, the

resistance, capacity, and inductance of the translating devices must be considered as well. In Fig. 22 is shown a diagram of a complete system with both step-up and step-down transformers connected in service. The charging current may be considered as flowing through half of the system only, namely, the generator, the step-up transformers, and one-half of the line.

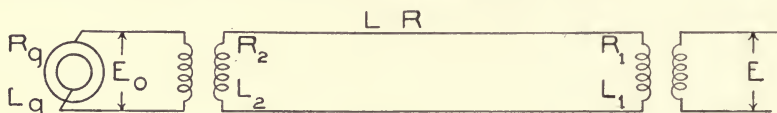

Fig. 22

Let  $R_1$  = the equivalent resistance of the step-down transformers.

$R_2$  = the equivalent resistance of the step-up transformers.

$L_1$  = inductance of the step-down transformers.

$L_2$  = inductance of the step-up transformers.

$R_g$  = equivalent resistance of the generators.

$L_g$  = equivalent inductance of the generators.

$R$  = resistance of the line.

$L$  = inductance of the line.

$L_T = L_1 + L_2 + L_g + L$ .

$R_T = R_1 + R_2 + R_g + R$ .

All quantities should be converted into their equivalent values for the full line pressure. Thus the generator and receiver voltages should be multiplied by the ratio of transformation of the step-up and step-down transformers, respectively, to change them to the full line pressure. The resistance and inductance of the transformers must include the resistance and inductance of both windings, and the value must correspond to the line voltage. Thus the resistance of the step-up transformers will be  $r_1 n^2 + r_2$ ,

when  $r_1$  = resistance of primary coil,

$r_2$  = resistance of secondary coil,

$n$  = the ratio of transformation. In the same way, the

equivalent resistance of the step-down transformers will be  $r_1 + n^2 r_2$ . The generator resistance and inductance must be multiplied by  $n^2$  to bring them to equivalent values for the full line pressure.

Our formula then becomes:—

$$E_o = E + I \cos \theta (R_T + jL_T \omega) - j I \sin \theta (R_T + jL_T \omega) + j I_c \left[ \left( \frac{R}{2} + R_2 + R_g \right) + j \omega \left( \frac{L}{2} + L_2 + L_g \right) \right]$$

Plotted graphically we have, Fig. 21:

$$\begin{array}{ll} oa = E & cd = I \cos \theta R_T \\ ab = j I_c \left( \frac{R}{2} + R_2 + R_g \right) & de = j I \cos \theta L_T \omega \\ bc = - I_c \omega \left( \frac{L}{2} + L_2 + L_g \right) & ef = -j I R_T \sin \theta \\ & fg = I L_T \omega \sin \theta \\ & og = E_o \end{array}$$

The numerical value of  $E$  and  $E_o$  may be determined, from a diagram such as is shown in Fig. 21, when constructed to scale; or it may be calculated analytically, remembering that the quantities affected by  $j$  are to be combined, geometrically, with the quantities not affected by the symbol.

The above formulæ apply to single-phase circuits directly. If to be used for the calculation of three-phase circuits, the following points must be observed:

1. Charging current ( $I_c$ ) three-phase =  $\frac{2}{\sqrt{3}} \times$  charging current single-phase.

2. The voltage should, preferably, be considered as the voltage between one line and the neutral point. The voltage to the neutral point will be the line voltage divided by  $\sqrt{3}$ .

3. The resistance of one line only is considered, not the resistance of a loop.

4. The inductance of one line only is used. The inductance of one line equals the inductance of a loop divided by  $\sqrt{3}$ .

### Examples of Alternating-Current Line Calculation.

1. What is the capacity, in micro-farads, between wires of a single-phase transmission line 10 miles in length composed of number 6 copper wire spaced 15 inches apart? What is the capacity to the neutral point?

$$C \text{ in farads} = \frac{19.42 \times 10^{-9}}{\log \frac{2A}{d}} \text{ per mile of circuit.}$$

$$A = 15 \text{ inches}$$

$$d = .162 \text{ inches.}$$

$$\frac{2A}{d} = 185$$

$$\log 185 = 2.2672$$

$$C \text{ in farads} = \frac{19.42 \times 10^{-9}}{2.2672} \times 10 = .000000085$$

$$C \text{ in micro-farads} = .000000085 \times 1,000,000 = .085$$

$$C \text{ in micro-farads with respect to the neutral point} = \frac{.0776}{2 \log \frac{2A}{d}}$$

$$C \text{ in micro-farads} = \frac{.0776}{2 \times 2.2672} \times 10 = .171$$

This shows that the capacity to the neutral point is twice the capacity to the other wire.

2. What is the self inductance of the above circuit?

$$L = .000558 \times \frac{2}{\sqrt{3}} \left( 2.303 \log \frac{2A}{d} + .25 \right) \text{ per mile of circuit.}$$

$$L = .000644 (2.303 \times 2.2672 + .25) \times 10 \\ = .000644 \times 5.47 \times 10 = .0352 \text{ henrys.}$$

3. A circuit has a capacity of .2 micro-farads. What must be the value of its inductance to compensate for this capacity at 60 cycles?

$$C = \frac{1}{(2\pi f)^2 L}$$

$$C = .0000002 \text{ farads}$$

$$(2\pi f)^2 = (2 \times 3.1416 \times 60)^2 = 142122$$

$$.0000002 = \frac{1}{142122 L}$$

$$L = 1 \div (142122 \times 0000002) = 35.2 \text{ henrys}$$

4. It is desired to transmit 1,000 K.W. a distance of 25 miles at a voltage of 20,000, a frequency of 60 cycles, and a power factor of 85%. Transmission is to be a three-phase three-wire system. Allowing 10% loss of delivered power in the line, required:

- a Area of conductor.
- b Current in each conductor.
- c Volts lost in line.
- d Pounds of copper.

$$a \text{ Circular mils} = \frac{D \times W \times C'}{p \times E^2}$$

$$D = 25 \times 5,280 = 132,000$$

$$W = 1,000 \times 1,000 = 1,000,000$$



$C' = 1,500$  for three-phase three wire system and 85% power factor.

$$p = 10$$

$$E = 20,000 \quad E^2 = 400,000,000$$

$$\begin{aligned} \text{Circular mils} &= \frac{132000 \times 1000000 \times 1500}{10 \times 400000000} = \\ &= \frac{132 \times 1500}{4} = 49,500. \end{aligned}$$

Number 3 wire has a cross-section of 52,400 cir. mils.

$$\text{b Current in each conductor} = \frac{W \times T}{E} = 34.$$

$T = .68$  for three-phase system, 85% power factor.

$$\text{c Volts lost in line} = \frac{p \times E \times B}{100}$$

$B = 1.18$  for number 3 wires, 60 cycles and 85% power factor.

$$\text{Volts lost} = \frac{10 \times 20,000 \times 1.18}{100} = 2360$$

$$\text{d Pounds copper} = \frac{D^2 \times W \times C' \times A}{p \times E^2 \times 1,000,000}; \text{ or it may be cal-}$$

culated directly from the weight of wire given in the tables after the size of wire has been determined by other formulæ. Thus 75 miles of number 3 wire is required. This weighs 159 pounds per 1,000 feet.

$$159 \times 5.280 \times 75 = 62,964 \text{ pounds.}$$

5. A single-phase line 20 miles in length is constructed of number 000 wire strung 24 inches apart. It is desired to transmit 500 K.W. over this line at a frequency of 25 cycles and a power factor of 80%, the voltage at the receiver end being 25,000. Considering the line drop only, what must be the voltage at the generator end of the line?

$$E_0 = E + I \cos \theta R + j I \cos \theta L \omega - j I \sin \theta R + I \sin \theta$$

$$L \omega + j \frac{I_c}{2} R - \frac{I_c}{2} L \omega.$$

$$E = 25,000$$

$$I = \frac{500,000}{25,000 \times .80} = 25 \quad (\text{Power} = IE \cos \theta)$$

$$\cos \theta = .80$$

$$\sin \theta = .60 \text{ (from trigonometric tables)}$$

R = resistance of 40 miles of number 000 wire = 14.56 ohms at 50° C.

$$L = .00277 \times \frac{2}{\sqrt{3}} \times 20 = .064 \text{ (calculated from Table V).}$$

$$\omega = 2\pi f = 2\pi \times 25 = 157$$

$$I_c = \frac{E \times C \times 2\pi \times f}{2 \times 10^6} = \frac{25,000 \times .3752 \times 157}{2 \times 1,000,000} = .736 \text{ Amp.}$$

$$C = .3752 \text{ (Table IV or calculated).}$$

Substituting these values in the above formula we have,

$$E_o = 25,000 + 291.2 + j200.8 - j218.4 + 150.6 + j5.36 - 3.7$$

$$E_o = 25,000 + 291.2 + 150.6 - 3.7 + j(200.8 - 218.4 + 5.36)$$

$$E_o = 25,000 + 291.2 + 150.6 - 3.7 - j(218.4 - 200.8 - 5.36)$$

$$E_o = \sqrt{(25,000 + 291.2 + 150.6 - 3.7)^2 + (218.4 - 200.8 - 5.36)^2}$$

Since the symbol  $j$  indicates that the quantities must be combined geometrically.

$$E_o = \sqrt{(25,438.1)^2 + (12.24)^2} = 25,438.1 \text{ volts.}$$

6. A three-phase line 20 miles in length is constructed of number 000 wire strung 24 inches apart. We wish to transmit 1,000 K.W. over this line at a frequency of 25 cycles and a power factor of 85%, the voltage at the receiving end being 2,000. Three Y-connected 500 K.W. transformers having a ratio of 10 : 1 step the voltage up and down at either end of the line. The resistance of the high-tension winding of each transformer is 4 ohms. The resistance of the low-tension windings is .04 ohms. The inductance of each transformer is 4 henrys. Neglecting the generator constants, what must be the voltage applied to the low-tension windings of the step-up transformers?

$$E_o = E + I \cos \theta (R_T + jL_T\omega) - jI \sin \theta (R_T + jL_T\omega) + jI_c$$

$$\left[ \left( \frac{R}{2} + R_2 \right) + j\omega \left( \frac{L}{2} + L_2 \right) \right]$$

Since this is for a three-phase circuit we will work with the voltage to the neutral point and will change all values to correspond to the line voltage. Hence,

$$\frac{E_o}{\sqrt{3}} \times 10 = \frac{E}{\sqrt{3}} \times 10 + \text{-----}$$

$I = 34$  amperes.

Since  $\sqrt{3} IE \cos \theta = 1,000,000$

$$E = 10 \times 2,000 = 20,000$$

$$\cos \theta = .85$$

$$I = 34.$$

$R_T =$  Resistance of one line + equivalent resistance of one transformer at each end of the line.

$$R_T = 7.28 \text{ ohms} + 4 + 100 \times .04 + 4 + 100 \times .04. \\ = 23.28 \text{ ohms.}$$

$$L_T = .0554 \div \sqrt{3} + .4 + .4 = .832 \text{ henrys.}$$

$$\omega = 157$$

$$\sin \theta = .52$$

$$I_c = .589 \times \frac{2}{\sqrt{3}} = .677 \text{ amp.} = \text{charging current single-}$$

$$\text{phase} \times \frac{2}{\sqrt{3}}.$$

$$\frac{R}{2} = 3.64$$

$$R_2 = 8$$

$$\frac{L}{2} = .016 \quad L_2 = .4$$

Substituting these values in our formula we have,

$$\frac{E_o \times 10}{1.73} = \frac{20,000}{1.73} + 672.8 + j 3774 - j 411.6 + 2309 \\ + j 7.88 - 44.2 \\ = 11,550 + 672.8 + 2,309 - 44.2 + j (3,774 - 411.6 + 7.88) \\ = \sqrt{14,487.6^2 + 3370.3^2} = 14,874 \\ E_o = 2,573 \text{ volts.}$$

#### TRANSFORMERS.

A transformer consists of two coils made up of insulated wire, the coils being insulated from each other and from a core, made up of laminated iron, on which they are placed. One of these coils, known as the primary coil, is connected across the circuit, in constant-potential transformers, and the other coil, known as the

secondary coil, is connected to the lamps or motors, or whatever makes up the receivers. As a matter of fact, these coils are each usually made up of several sections. The voltage induced in the secondary windings is equal to the voltage impressed on the primary winding multiplied by the ratio of the number of turns in the secondary to the number in the primary coil, less a certain drop due to impedance of the coils and to magnetic leakage. This drop is negligible on no load. If transformers are used to raise the voltage, they are termed *step-up* transformers. If used to lower the voltage, they are called *step-down* transformers.

Losses of power occurring in transformers are of two kinds namely:

**Iron or core losses** which are made up of hysteresis and eddy-current losses in the iron making up the core, and

**Copper losses** which are due to the  $I^2R$  losses in the windings with the addition, in some cases, of eddy currents set up in the conductors themselves.

**The efficiency** of a transformer depends on the value of these losses and may be expressed as the ratio of the watts output to the watts input.

$$\frac{W_s}{W_p} = \frac{W_p - (W_c + W_h + W_e)}{W_p}$$

$W_s$  = watts secondary.

$W_p$  = watts primary.

$W_c$  = copper losses.

$W_h$  = hysteresis losses.

$W_e$  = eddy current losses.

The iron losses remain constant for any given voltage regardless of the load, while the copper losses are proportional to the square of the current. The efficiencies of transformers are high, varying from 94 to 95% at  $\frac{1}{4}$  load to 98% at full load for sizes above 25 K.W.

**By All-Day Efficiency** is meant the efficiency of a transformer, taking into consideration its operation for twenty-four hours, and it is calculated for the ratio of watt-hours output to watt-hours input for this length of time when in actual service. For calculation, the transformer is often assumed to be fully loaded

for five hours and run with no load for the remaining nineteen. The all-day efficiency is then determined as follows:

Output, K.W. hours = watts output at full load  $\times 5$ .

Input, K.W. hours = watts output at full load  $\times 5 + I^2R$  loss at full load  $\times 5 +$  core loss at normal voltage  $\times 24$ .

$$\text{All-day efficiency} = \frac{\text{output, watt-hours}}{\text{input, watt-hours.}}$$

The assumption that a lighting transformer is fully loaded five hours out of the day is not always a correct one. On many circuits from two to three hours of full load would be more nearly the proper value to use in calculating the all-day efficiency.

**By Regulation** of a transformer is meant the percentage drop in the secondary voltage from no load to full load when normal pressure is impressed on the primary. This drop is due to the  $IR$  drop in the windings and to magnetic leakage. In well designed transformers the loss due to magnetic leakage is about 10%, or less, of that due to the resistance drop. For non-inductive load (power factor = unity) the regulation is from 1 to 3% in good transformers. With induction load this is increased to 4 or 5%, or even more.

Both the efficiency and the regulation should be considered in selecting a transformer for given service. Thus, if a transformer is to be used for lighting, its regulation should be of the best, since drop in voltage due to the transformer is in addition to that due to the conductors. In the same way the regulation of any system as a whole depends to a certain extent on the regulation of the transformer installed.

If the efficiency of a transformer is low, it means a direct loss of considerable energy as well as greater heating of the transformer and consequent deterioration. If a transformer is to be used for lighting purposes, or is lightly loaded, a large portion of the time,

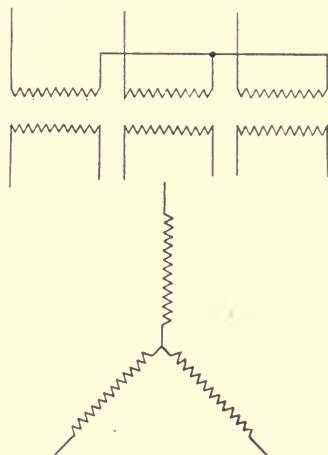

Fig. 23.



a type should be selected which has a relatively low core loss so as to increase the all-day efficiency. If fully loaded all day, the losses should be divided about equally between the copper and the iron losses.

**Transformer Connections.** Transformers for three-phase work may be connected in two ways. Where three transformers are used, they may be connected in Y or star, that is, with one terminal of each primary brought to a common point and the other

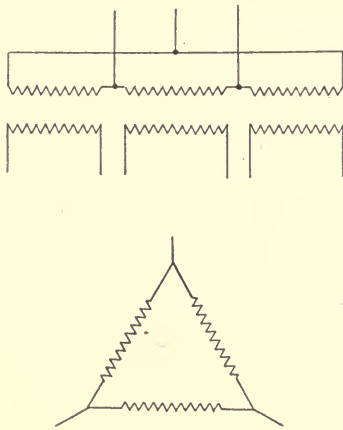

Fig. 24.

terminal connected to a line wire (see Fig. 23), or they may be connected in  $\Delta$  or mesh when the three primaries are connected in series and the line wires are connected to the three corners of the triangle so formed (see Fig. 24). The secondaries may be connected in Y the same as the primaries or the secondaries may be connected in Y when the primaries are in  $\Delta$ , or *vice versa*. The voltage relation may be best determined from vector diagrams as shown in Fig. 25, which gives the voltage relation of step-down trans-

formers with a ratio of 10 : 1, when the voltage across the primary lines is 1,000.

Changes may be made from two to three phases, or from three to two phases, with or without a change of voltage, by means of transformers having the required ratio of transformation by use of what is known as the *Scott* connections. Fig. 26 shows such a connection together with a corresponding vector diagram showing the relations when the change is from two to three-phase with a 10 : 1 transformation of voltage. The *main* transformer is fitted with a tap at the middle point of the secondary wiring to which one terminal of the *teaser* transformer is connected. The *teaser* has a ratio of transformation differing from that of the main transformer, as shown in the figure.

*Six Phases* are obtained from three phases for use with rotary converters by means of transformers having two secondary

windings or by bringing both ends of each winding to opposite points on the rotary-converter winding, utilizing the converter winding for giving the six phases. The latter, shown in Fig. 27, is known as a diametrical connection. When transformers with

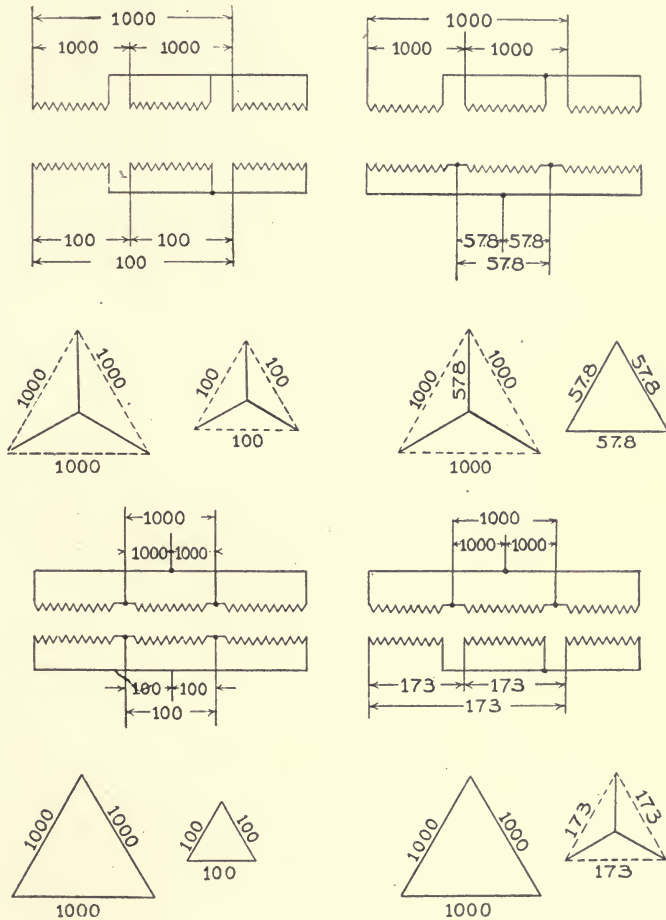

Fig. 25.

two secondaries are used, the secondaries may be connected in six-phase Y or six-phase  $\Delta$  as shown in Figs. 28 and 29. When the Y-connection is used, the common connection of each set of secondaries is made at the opposite ends of the coils. This leaves the free ends directly opposite or  $180^\circ$  different in phase. The way in

which these ends are brought out to give six phases is best illustrated by means of the two triangles arranged as shown in Fig. 30, which have their points numbered corresponding to the connec-

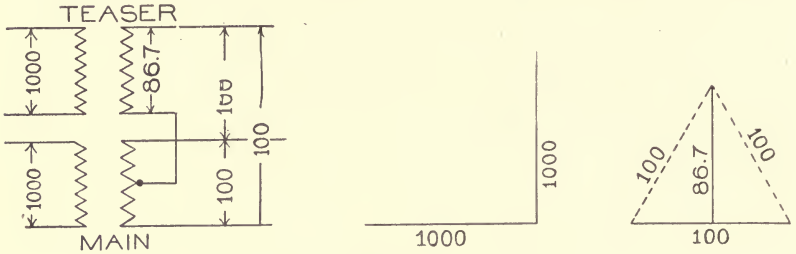

Fig. 26.

tion in Fig. 28. In Fig. 29 one  $\Delta$  is reversed with respect to the other, and six phases are brought about in this manner.

Single transformers, constructed for three-phase and six-phase work, are now being manufactured in this country, and they are

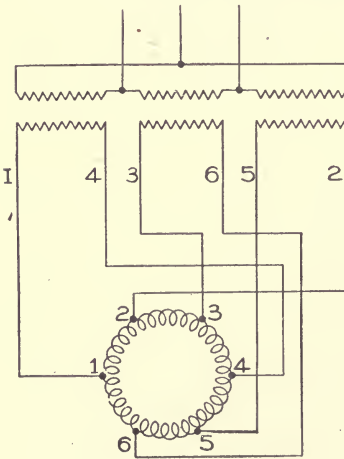

Fig. 27.

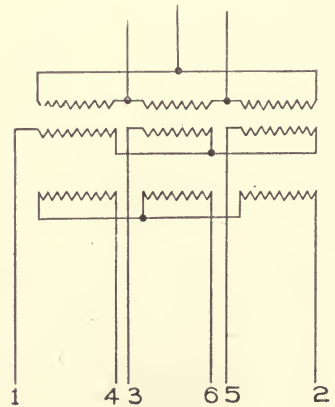

Fig. 28.

being used to an increasing extent. They are a little cheaper to build for the same total output, and save floor space, but are not so flexible as three single-phase transformers.

Where other conditions allow, a  $\Delta$  to  $\Delta$ -connection is preferable, for with this connection, if one transformer is injured, it

may be taken out of circuit and the remaining two will maintain the service, and may be loaded up to  $\frac{2}{3}$  of the former capacity of the system. In the Y-connection, however, the voltage impressed

on the transformer winding is only  $\frac{1}{\sqrt{3}} = .58$  times the voltage of the line, thus making it possible to construct a transformer

with a fewer number of turns. The windings must be insulated from the case, however, for a potential equal to the line potential, unless the neutral point be grounded when the potential strain to which the transformer is liable to be subjected, under ordinary

conditions, is reduced to  $\frac{1}{\sqrt{3}}$  of its value when the neutral is not

grounded. For small transformers wound for high potential the cost is in favor of the Y-connection.

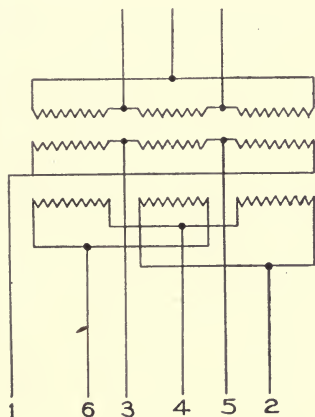

Fig. 29.

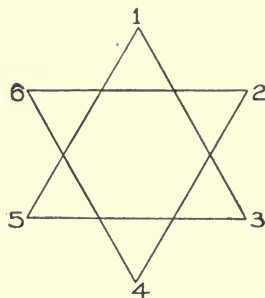

Fig. 30.

**Choice of Frequency.** The frequencies in extended use at present in this country are 25, 40, and 60 cycles, 25 or 60 cycles being met with more frequently than 40 cycles. Formerly, a frequency of 125 or 133 cycles per second was quite often employed for lighting purposes, but these are no longer considered standard.

The advantages of the higher frequency are:

1. Less first cost and smaller size of generators and transformers for a given output.

2. Better adapted to the operation of arc or incandescent lamps. Lamps, when run below 40 cycles, especially low candle-power incandescent lamps at 110 volts or higher, are liable to be trying to the eyes on account of the flicker.

Its disadvantages are:

1. Inductance and capacity effects are greater, hence a poorer regulation of the voltage. The charging current is directly proportional to the frequency and this amounts to considerable in a long line.

2. There is greater difficulty in parallel operation of the high-frequency machines due to the fact that the armature reactions of the older types of high-frequency machines are high.

3. Machines for high frequencies are not so readily constructed for operation at slow speeds. This, however, will cease to be an objection with the increasing use of the steam turbine.

4. Not well adapted to the operation of rotary converters and single-phase series motors on account of added complications in construction and increased commutator troubles.

A frequency of 60 cycles is usually adopted if the power is to be used for lighting only, and 25 cycles are better for railway work alone. By the use of frequency changers the frequency of any system may be readily changed to suit the requirements of the service.

#### OVERHEAD LINES.

Having considered the calculation of the electrical constants of a transmission line and distributing system, we turn next to the mechanical features of the installation of the conductors and find two general methods of running the wires or cables.

In the first method the conductors are run overhead and supported by insulators attached to pins in cross-arms which, in turn, are fastened to the supporting poles. In the other methods the cables are placed underground and are supported and protected by some form of conduit.

Overhead construction is used when the lines are run through open country or in small towns. It forms a cheap method of providing satisfactory service and is reliable when carefully installed. It has the advantage that the wires may be placed some distance apart and, being air-insulated, the capacity of the line is much less than that of underground conductors.

The old practice in overhead line construction has always been to consider the design and erection of the line as work that anyone could do, it being taken as the simplest part of the electrical system. As a result, the line was a source of a great deal of trouble which was laid to almost any other cause than poor construction. The overhead line, when used, must be considered as a part of the



power plant and it should receive as careful attention as any part of the central station or substation. It often has to meet much more severe conditions than the power plant itself and it is responsible to a very large extent for the reliability of service.

The new way of treating the question of overhead lines is to consider them as structures which must be designed to meet certain strains just as a bridge or similar structure is designed. This is especially true when steel or iron poles are used as is the case in nearly all transmission lines abroad.

The design of an overhead line may be divided into five parts:

1. Location of line.
2. Supports for the line, pole, and cross-arms.
3. Insulators and pins.
4. Stresses sustained by the pole line.
5. Conductors, material, size.

Some of these are purely mechanical features while others are both mechanical and electrical. Let us take them up in the order named.

**Location of Line.** The location of the line takes into account the territory over which the line must be run with respect to contour, direction, and freedom from obstructions as well as possible right of way. Width of streets, kind and height of buildings, liability to interference with or from other systems must be considered, when such are present. The right of way for electric lines may be secured, in some cases, along a railway or public road when its location is comparatively simple, provided it is not necessary to interfere with adjoining property. When adjoining property must be interfered with, or when the line is to run over sections containing no roads, it is usually possible to form contracts with the property owner such as shall free the line from future interference by the property owner. In general, the cost of such contracts will be comparatively low. Again, the right of way may be purchased outright as is preferable when right of way is being secured for high-speed electric railways. When the demands for right of way are in excess of a reasonable amount, the process of condemnation of property may be resorted to or the direction of the line may be changed so as to avoid such locations. A preliminary survey of the line should be made at the time the route is

being located, such a survey consisting of the approximate location of the poles, notes of the changes in direction and level of the ground as well as of its character. This survey aids in the selection of material to be delivered to the different parts of the line. Changes in level are compensated for as much as possible by selecting long poles for the low places and short poles for the higher elevations, thus reducing the unbalanced strains in the line.

The heavier poles should be used where there is a change in direction, where the line is especially exposed to the wind or where branch lines are taken off. It is sometimes necessary that power lines be run on the same poles as telephone wires, in which case the power conductors should, preferably, be located above the telephone wires.

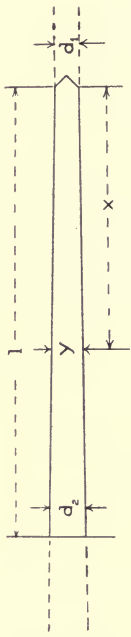

Fig. 31.

**Supports, Poles.** In this country, the support for aerial lines consists almost universally of wooden poles to which the cross-arms, bearing the insulator pins, are attached. These poles may be either natural grown or sawn. Abroad, the use of metal poles prevails. In order to determine the proper cross-section of a pole it may be regarded as a beam fixed at one end and loaded at the other, this load consisting of the weight of the wire, with attendant snow or sleet, which tends to produce compression in the pole, and the tension of the wires together with the effect of wind pressure, which tends to produce flexure. Only the latter stresses need be considered in selecting a pole for ordinary transmission lines. The poles are in the

shape of a truncated cone or pyramid, the equation of which is:

$$y = d_1 + x \left( \frac{d_2 - d_1}{l} \right). \quad \text{See Fig. 31.}$$

$y$  = diameter of any section.

$x$  = distance from the top of the pole.

$l$  = length of pole.

$d_1$  and  $d_2$  = diameter of the pole at the top and bottom respectively.

The proper taper for a pole should be such that  $d_2 = \frac{3}{2}$  of  $d_1$ . If  $d_2 > \frac{3}{2} d_1$  the pole is heavier than need be as it would tend to break below the ground. If less than  $\frac{3}{2} d_1$ , the pole will tend to break above the ground and the material is not distributed to the best advantage.

In calculating the size of pole necessary to stand a certain stress, we have, from the principles of Mechanics,

$$M = \frac{S I}{\frac{d_2}{2}}$$

$M$  = moment of resistance.

$I$  = moment of inertia.

$S$  = stress in the section at  $d_2$  at which point the pole is least able to withstand the strain which comes on it.

$M = Pl$  where  $P$  is the tension in the wires and  $l$  = length of pole in inches.

$$\text{For a round pole, } I = \frac{\pi d_2^4}{64}$$

$$\text{and we have, } Pl = \frac{\frac{S\pi d_2^4}{64}}{\frac{d_2}{2}} = \frac{S\pi d_2^3}{32}$$

$$\text{Solving for } S, S = \frac{32 Pl}{\pi d_2^3}$$

For a sawn pole with square cross-sections the value of  $I$  is:

$$I = \frac{d_2^4}{12}$$

$$\text{and } Pl = \frac{S d_2^3}{6} \text{ or } S = \frac{6 Pl}{d_2^3}$$

The value for  $S$  should not exceed a certain proportion of the ultimate strength of the material. If  $T$  represents the ultimate strength in pounds per square inch, then  $P = \frac{T}{n}$  where  $n$  is known as the factor of safety and is ordinarily not taken less than 10 for wooden structures. A high factor of safety is necessary on account

of the material not being uniform, and the uncertainty of the value of  $T$ .

Following are commonly accepted values of  $T$ :

Yellow pine.....	5,000 - 12,000 pounds
Chestnut.....	7,000 - 13,000 "
Cedar.....	11,500 "
Redwood.....	11,000 "

The value of  $\frac{T}{u}$  should not be over about 800 for natural poles and 600 for sawn poles.

$d_2$  is measured at the ground line of the pole, not at the base.

Consider a pole of circular cross-section having a length of 35 feet and a diameter at the ground line of 12 inches. Using  $\frac{T}{u} = 600$ , what is the maximum allowable stress that should be applied at the end of the pole?

$$S = \frac{32 Pl}{\pi d_2^3}$$

$$P = 600$$

$$l = 35 \times 12 = 420 \text{ inches.}$$

$$d_2 = 12$$

$$S = \frac{32 \times 600 \times 420}{3.1416 \times 1728} = 1,485 \text{ lbs.}$$

It is customary to select a general type of pole for the whole line determined from calculations based on the above formulæ, after the tension in the wire has been found, and not to apply such calculations to every section of the line. The line is then reinforced, where necessary, by means of guy wires or struts.

Following are some of the general requirements for poles:

Spacing should not exceed 40 to 45 yards.

Poles should be set at least five feet in the ground with an additional six inches for every five feet increase in length over thirty-five feet. Special care in setting is necessary when the ground is soft. End and corner poles should be braced and at least every tenth pole along the line should be guyed with  $\frac{1}{4}$  or  $\frac{3}{8}$ -inch stranded galvanized iron wire.

Regular inspection of poles, at least yearly, should be maintained and defective poles replaced. The condition of poles is best determined by examination at the base.

Poles should preferably be of good, sound chestnut, cedar, or redwood. Other kinds of wood are sometimes used, the material depending largely on the section of the country in which the line is to be erected and the timber available. Natural poles should be shaved, roofed, gained, and given one coat of paint before erecting.

Special methods of preserving poles have been introduced, chief among which may be considered the process of creosoting. Creosoting consists of treating the poles with live steam at a temperature of 225 to 250°, so as to thoroughly heat the timber, after which a vacuum is formed and then the containing cylinder is pumped full of the preserving material, a pressure of about 100 pounds per square inch being used to force the desired amount of material into the wood. The butts of poles are often treated with pitch or tar, but this should only be applied after the pole is thoroughly dry.

Guying of pole lines is one of the most important features of construction. Guys consist of three or more strands of wire, twisted together, fastened at or near the top of the pole, and carried to the ground in a direction opposite to that of the resulting strain on the pole line. The lower end is attached to some form of guy stub or guy anchor. This may be a tree, a neighboring pole, a short length of pole set in the ground, or a patent guy anchor. Guy stubs are set in the ground at an inclination such that the guy makes an angle of 90° with the stub or with the axis of the stub in the direction of guy, the stub in the latter case being held in place by timber or plate fastened at right angles to the bottom of the stub. Such a timber is known as a "dead man".

The angle the guy wire makes with the pole should be at least 20°. When there is not room to carry the guy far enough away from the base of the pole to bring this angle to 20° or more, a strut may be used. This consists of a pole slightly shorter and lighter than the one to be reinforced. It is framed into the line pole near the top and set in the ground at a short distance from the base of the pole on the opposite side of the pole from that on which a guy would be fastened.

Stranded galvanized steel guy wire is used for guys. There are two general methods of attaching the guys to the top of the pole. In the one, a single guy is run, attached at or near the



middle cross-arm, while in the other, known as "Y" guying, two wires are run to the top of the pole, one at the upper the other at the lower arm, and these united into a single line a short distance from the pole.

Head guying, guying in the direction of the line, is used when the line is changing level and for end poles. The guys are attached

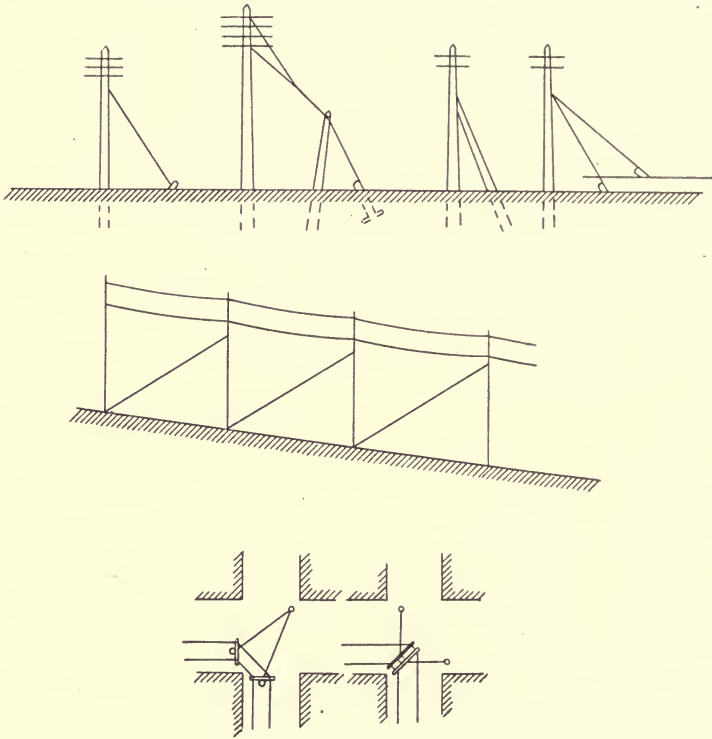

Fig. 32.

near the top of one pole and run to the bottom of the pole just above. Fig. 32 shows several methods of reinforcing pole lines. Special methods are adapted as necessary.

**Cross-Arms.** The best cross-arms are made of southern yellow pine. Oak is also used to a large extent. They should be of selected well-seasoned stock. The usual method of treatment is to paint them with white lead and oil. The size of cross-arms and spacing of pins have not been thoroughly standardized. For cir-

cuits up to 5,000 volts,  $3\frac{1}{4} \times 4\frac{1}{4}$  or  $3\frac{3}{4} \times 4\frac{1}{4}$ " cross-arms with spacing between pins of 16 inches, the pole pins being spaced 22 inches, are recommended. For higher voltages, special cross-arms and spacings are necessary. The cross-arms should be spaced at least 24 inches between centers, the top arm being placed 12 inches below the top of the pole. They are usually attached to the pole by means of two bolts and are braced by galvanized iron braces not less than  $1\frac{1}{4} \times \frac{3}{16}$  inch and about 28 inches long.

Cross-arms are placed on alternate sides of the poles so as to prevent several of them from being pulled off should one become broken or detached. On corners or curves double arms are used. In European practice, the cross-arm is done away with to a large extent, the wire being mounted on insulators attached to iron brackets mounted one above the other. Fig. 33 gives an idea of this construction.

**Insulators.** Electrical leakage between wires must be prevented in some way and various forms of insulators are depended upon for this purpose. The material used in the construction of these insulators should possess the following properties: high specific resistance; surface not readily destroyed and one on which moisture

does not readily collect; mechanical strength to resist both strain and vibrating shocks. Its design must be such that the wire can be readily fastened to it and the tension of the wire will be transmitted to the pin without producing a strong strain in the insu-

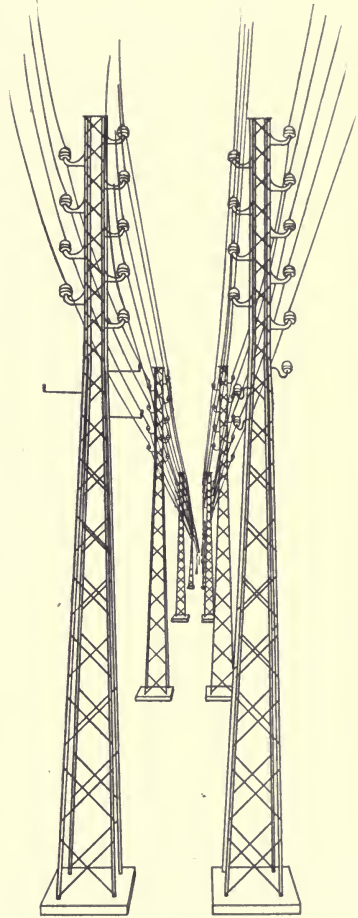
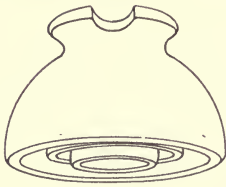

Fig. 33.

HEIGHT  $3\frac{3}{4}$ " TESTED AT 50,000V

HEIGHT 3" TESTED AT 30,000V.

HEIGHT  $4\frac{1}{2}$ " TESTED AT 70,000V.HEIGHT  $7\frac{1}{4}$ " TESTED AT 80,000V.HEIGHT  $4\frac{3}{8}$ " TESTED AT 50,000V.HEIGHT  $4\frac{1}{4}$ " TESTED AT 50,000V.HEIGHT  $3\frac{1}{4}$ " TESTED AT 40,000V.HEIGHT  $4\frac{1}{4}$ " TESTED AT 40,000V.

Fig. 34.

lator. Leakage surface must be ample for the voltage of the line and so constructed that a large portion of it will be protected from moisture during rainstorms. The principal materials used are glass and porcelain.

Porcelain has the advantage over glass that it is less brittle and generally stronger and that it is less hygroscopic, that is, moisture does not so readily collect on and adhere to its surface. Glass is less conspicuous and is cheaper for the smaller insulators. Both materials are freely used for the construction of high-tension lines, while the use of glass prevails for the low-tension circuits.

All line insulators are of the petticoat type and are made up in various shapes and sizes. The larger size porcelain insulators are made up in two or more pieces which are fastened together by means of a paste formed of litharge and glycerine. The advantages of this form of construction are greater uniformity of structure,

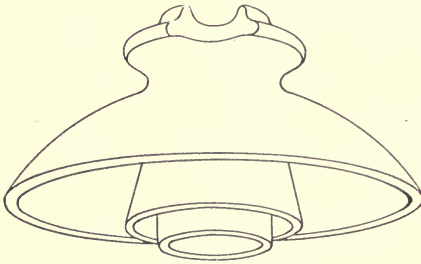
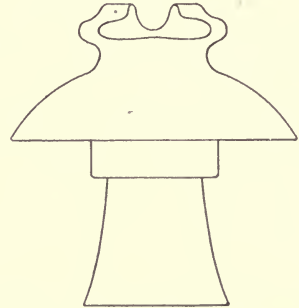
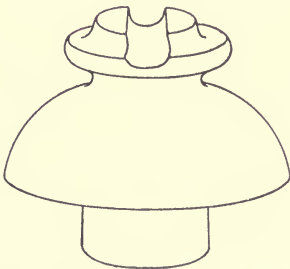
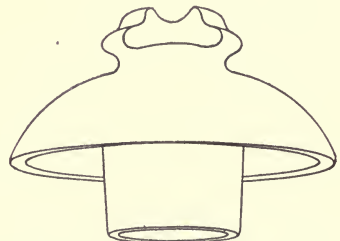
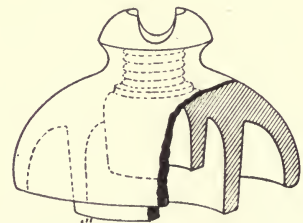
and each part may be tested separately. Fig. 34 shows several forms of insulators now in use with the voltage at which they are tested. The test applied to an insulator for high-tension lines should be at least double the voltage of the line, and some engineers recommend three times the normal voltage.

**Pins.** Pins made of locust wood boiled in linseed oil are preferred for voltages up to 5,000. Above this special pins are used. Wood pins are often objected to on account of the burning or charring which takes place in certain localities, and iron pins are being used to a large extent. Fig. 35 shows the dimensions of such

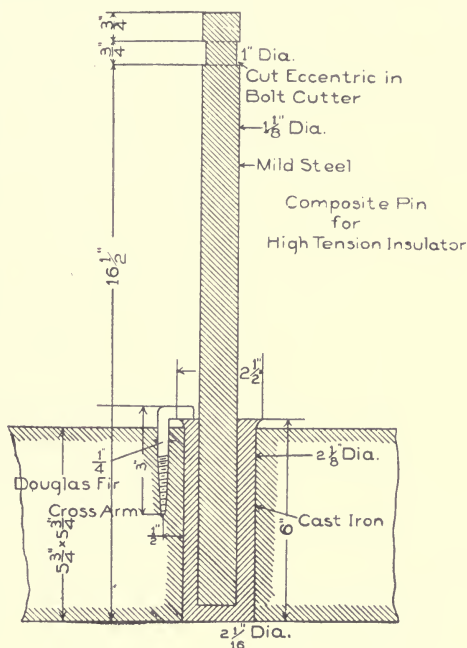

Fig. 35.

a pin used on a 60,000-volt line. The insulator is fastened to the pin by means of a thread in a lead lug which is cast on top of the pin. The insulators in the construction shown in Fig. 33 are cemented to the iron brackets.

**The Stresses sustained by the line** may be classified as follows:

1. Weight of wire, which includes insulation, and snow and sleet which may be supported by the wire.
2. Wind pressure upon the parts of the line.

The strain produced by the weight of the wire on the pole itself need not be considered except in exceptional cases, because if the pole is sufficiently strong to withstand the bending strains, it is more than strong enough to withstand the compression due to the weight of the wires.

3. Tension in the wire itself.

Langley shows the pressure of the wind normal to flat surfaces to be equal to:

$$p = .0036 v^2 = \frac{v^2}{280}$$

$p$  = pressure in pounds per sq. ft.

$v$  = velocity in miles per hour.

For cylindrical surfaces the amount of pressure is  $\frac{2}{3}$  that exerted on a flat surface of a width equal to the diameter of the cylinder. Without great error we may assume that the maximum wind pressure, and that for which calculation is necessary, is that at right-angles to the line, and a value of thirty pounds per square foot is sufficient allowance for exposed places, while twenty pounds per square foot is considered sufficient where the line is partially sheltered.

*Example.* What is the pressure, due to the wind, on the wires of a pole line containing three number 0000 wires, the poles being spaced 45 yards and the velocity of the wind such that the pressure may be taken as 30 pounds per square foot.

The diameter of a number 0000 wire is .460 inch. The area against which the wind exerts its force may be considered as:

$$\frac{2}{3} \times \frac{3 \times 45 \times 3 \times 12 \times .460}{144} = 5.166 \text{ square feet.}$$



$5.166 \times 30 = 155$  pounds pressure due to wind on wires.

The most important strain-producing factor in a line is that due to the tension in the wire itself. A wire suspended so as to hang freely between two supports assumes the form of curve known as a catenary, but for ordinary work the curve may be taken as a parabola the equation of which is simple and from which the following equations are derived :

$$D = \frac{H^2 W}{8P_c}$$

$$P_c = \frac{H^2 W}{8D}$$

$$L = H + \frac{8D^2}{3H}$$

When  $D$  = deflection or sag at lowest point in feet.

$L$  = actual length of wire between supports in feet.

$H$  = distance between supports in feet.

$W$  = weight of wire in pounds per foot.

$P_c$  = horizontal tension in the wire at the middle point.

$P_c = \frac{T}{n}$  where  $T$  = tensile strength of the wire and  $n$  =

factor of safety.  $n = 2$  to  $6$  under the conditions existing when the wire is erected. The temperature changes in the wire affect the value of this factor, it being greatest when the temperature is a maximum, and a minimum when the temperature is lowest, and calculation should be for the maximum strain that may come on the wires.

If  $L_t$  = length of a wire at a given temperature,  $t$  °C.

and  $L_{20}$  = length of a wire at a given temperature,  $20$  °C.

Then,  $L_t = L_{20} [1 + k(t - 20)]$ .

$k = .000012$  for iron.

$.0000108$  to  $.0000114$  for aluminum.

$.0000172$  for copper.

The following table gives the deflection of spans of wire in inches for different temperatures and different distances between poles, a maximum stress of 30,000 pounds per square inch being allowed at  $-10$ ° F, which gives a factor of safety of 2 for hard-drawn copper wire.

TABLE VII.  
Temperature Effects in Spans.

Spans in Feet.	TEMPERATURE IN DEGREES FAHRENHEIT.								
	- 10°	30°	40°	50°	60°	70°	80°	90°	100°
	Deflection in Inches.								
50	.5	6	8	9	9	10	11	11	12
60	.7	8	10	11	11	12	13	13	14
70	1.	10	11	12	13	14	15	15	17
80	1.2	11	13	14	15	16	17	18	19
90	1.6	13	14	16	17	18	19	20	21
100	1.9	14	16	17	19	20	21	23	24
110	2.3	16	18	19	21	22	24	25	26
120	2.8	17	19	21	22	24	26	27	28
140	3.7	20	23	25	27	28	30	32	33
160	4.9	23	26	28	30	32	34	36	38
180	6.2	26	29	32	34	37	39	41	43
200	7.7	31	33	36	38	41	43	45	48

The above formulæ apply directly to lines in which the poles are the same distance apart and on the same level, and any number of spans may be adjusted at one time by applying the calculated stress at the end of the wire and the line will be in equilibrium; that is, there will be no strain on the poles in the direction of the wires. Special care must be taken to preserve this equilibrium when the length of span changes or when the level of the pole tops varies, and this is accomplished by keeping  $P_c$  and  $n$  constant for every span.

What is the tension in pounds per square inch at the center of a span of number 0000 wire when the poles are 120 feet apart and the sag is 16 inches?

$$P_c = \frac{H^2 W}{8D}$$

$$H = 120$$

$$D = \frac{16}{12} = 1\frac{1}{3} \text{ feet.}$$

$$W = .64 \text{ pounds.}$$

$$P_c = \frac{(120)^2 \times .64}{8 \times 1\frac{1}{3}} = 864 \text{ pounds}$$

The cross-section of number 0000 wire is,—

$$\pi \times (.23)^2 = .1662 \text{ square inches.}$$

$$864 \div .1662 = 5200 \text{ pounds per square inch.}$$

The regulation of the system and the amount of power lost in transmission together determine the cross-section of the conductors to be used. The amount of power lost, for most economical operation can be determined from the cost of generating power and the fixed charges on the line investment. Either copper or aluminum wire or cables may be used. The latter is lighter in weight but more care must be taken in erecting and it is more difficult to make joints.

#### UNDERGROUND CONSTRUCTION.

In large cities or other localities where, if overhead construction be used, the number of conductors becomes so great as to be objectionable, not alone on account of appearance but also on account of complication and danger, the lines are run underground. The expense of installing underground systems is very great compared with that of overhead construction, but the cost of maintenance is much less and the liability to interruption of service, due to line troubles, greatly reduced. The essential elements of an underground system are the conductor, the insulator, and the protection. The conductor is invariably of copper, the insulator may be rubber, paper, some insulating compound, or individual insulators, depending on the system, while the protection takes one of several forms. The system, as a whole, may be divided into

Solid or built-in systems.

Trench systems.

Drawing-in systems.

As an example of the first, we have the *Edison Tube system*, which is especially adapted to house-to-house distribution and is used to a large extent for direct-current three-wire distribution in congested districts. It is made up of copper rods as conductors (three of equal size for mains and the neutral but  $\frac{1}{2}$  the size of the main conductors in feeders), which are insulated from each other by an asphaltum compound. This compound also serves as an insulation from the protecting case, which consists of wrought-iron pipe. Pilot wires are also often installed in the feeder tubes. This tube is built up in sections about twenty feet long. In insulating the conductors, they are first loosely wrapped with jute rope so as to keep them from making contact with each other,

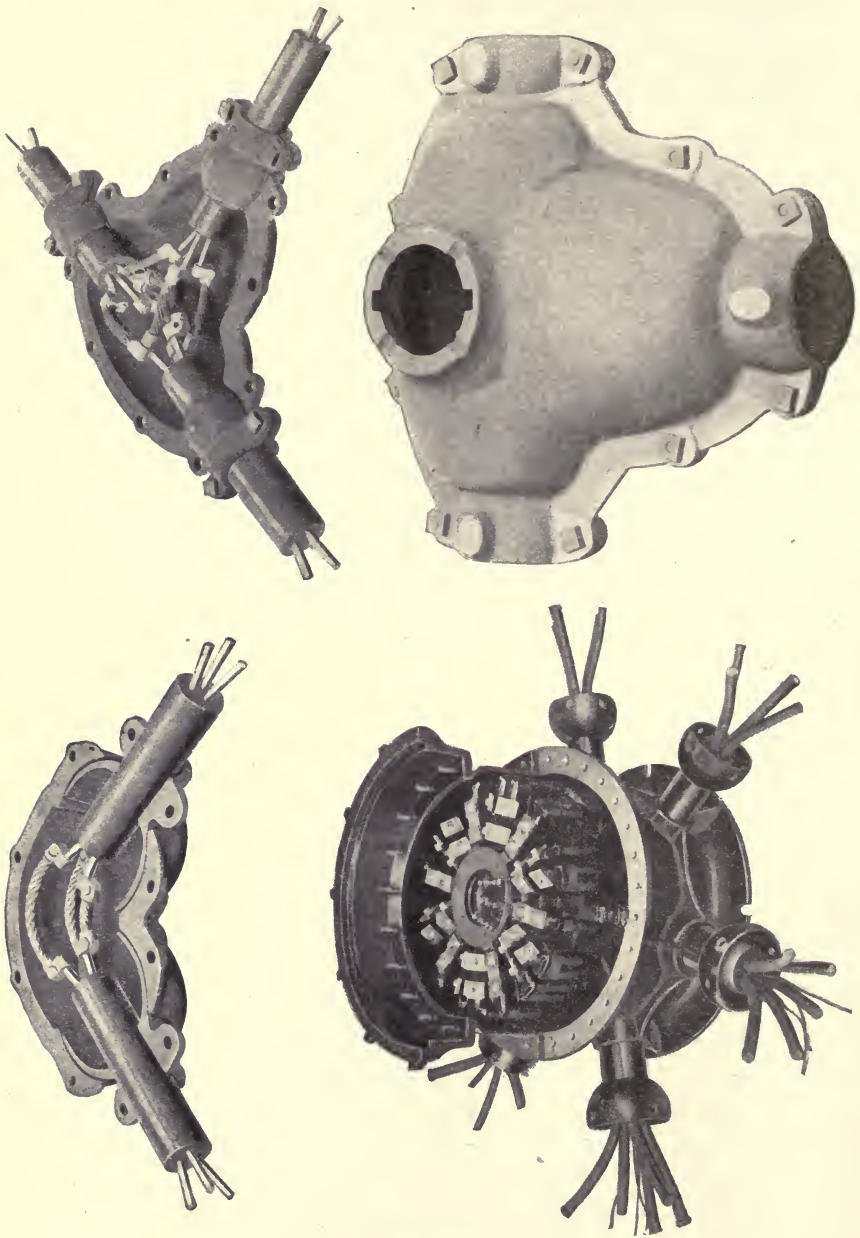

Fig. 36.



and with the pipes, and the heated asphaltum forced into the tube from the bottom, when the tube is in a vertical position. The ends of the conductors and the tubes must be joined and properly insulated in a completed system. Special connectors are furnished for the conductors, and cast-iron coupling boxes are fitted to the ends of the tube as shown in Fig. 36. After the conductors are properly connected, the cap is put on this coupling box and the inside space then filled with insulating compound through a hole in the cap. This hole is later fitted with a plug to render the box air-tight. The system is a cheap one, though the joints are expensive. It is not adapted to high potentials.

The *Siemens-Halske* system of iron-taped cables consists of insulated cables encased in lead to keep out moisture, this lead sheathing being in turn wrapped with jute which forms a bedding for the iron tape. The iron tape is further protected by a wrapping thoroughly saturated with asphaltum compound. These cables may be made up in lengths of from 500 to 600 feet.

In unexposed places, such as across private lands, the steel taping may be omitted and the lead sheathing simply protected by a braid or wrapping saturated with asphaltum.

The *Trench* system consists of bare or insulated conductors supported on special forms of insulators as in overhead construction, the whole being installed in small closed trenches. As this system is not used to any extent in America, but one system, the Crompton system, will be described.

In the Crompton system, bare copper strips are used, each 1 to  $1\frac{1}{2}$  inches wide and  $\frac{1}{4}$  to  $\frac{1}{2}$  inch thick. These strips rest in notches on the top of porcelain or glass insulators, supported by oak timbers embedded in the sides of the cement-lined trench. This trench is covered with a layer of flagstone. These insulators are spaced about 50 feet and about every 300 feet a straining device is installed for taking up the sag in the conductors. Hand-holes are located over each insulator.

There are several of the *drawing-in* systems, and certain of these have come to be considered standard underground construction in the United States. It is no longer deemed advisable to construct ducts which will serve as insulators, but they are de-



- pended on for mechanical protection only, and should fulfill the following requirements:

They must have a smooth interior, free from projections, so that the cables may be readily drawn in and out.

They must be reasonably water-tight.

They must be strong enough to resist injury due to street traffic and accidental interference from workmen.

Among the materials used for duct construction may be mentioned: iron or steel, wood, cement, and terra cotta. *Wood* is used in the form of a trough or box, or in the form of wooden

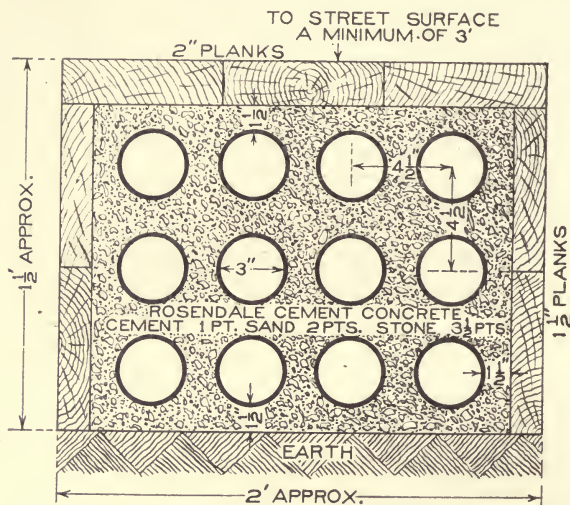

Fig. 37.

pipes. The latter is known as "pump log" conduit. The wood used for this purpose must be very carefully seasoned and then treated with some antiseptic compound, such as creosote, in order for the duct to give satisfactory service. If improperly treated, acetic acid is formed during the decay of the wood, and this attacks the lead covering of the cable, destroying it and allowing moisture to deteriorate the insulation. Wood offers very little resistance to the drawing in of the cables, and it is a cheap form of conduit, though it cannot be depended on for long life.

One of the best and at the same time most expensive systems is the one using *wrought-iron pipes*, laid in a bed of concrete. The ordinary construction of the duct consists of digging a trench

of the desired size and covering the bottom, after it is carefully graded, with a layer of good concrete from two to four inches thick. Such a cement may consist of Rosendale cement, sand, and broken stone in the ratio of 2, 3, 5, the broken stone to pass through a sieve of  $1\frac{1}{2}$ -inch mesh. The sides of the trench are lined with  $1\frac{1}{2}$ -inch planks. The first layer of pipes consisting of wrought-iron pipes 3 to 4 inches in diameter, 20 feet long, and  $\frac{1}{4}$  inch thick, joined by means of water-tight couplings, is laid on this concrete, and the space around and above them filled with concrete. A second layer of pipes is laid over this, and so on. A covering of concrete 2 to 3 inches thick is placed over the last layer, and a layer of 2-inch plank is placed over all, to protect against injury by workmen. Fig. 37 shows a cross-section of such duct construction. The pipe should be reamed so as to remove any internal burrs which might injure the insulation during the process of drawing in.

A modification of this system consists of the use of *cement-lined wrought-iron pipes*. This usually consists of eight-foot lengths made of riveted sheet-iron pipes. Rosendale cement is used for the lining, this lining being about  $\frac{5}{8}$  inch thick. The external diameter of the pipe is about  $4\frac{1}{2}$  inches. The outside of the pipe is coated with tar to prevent rusting. The sections have a very smooth interior and are light enough to be easily handled. They are embedded in concrete, similar to the system previously described. Connections between the sections are made by means of joints, constructed on the ball-and-socket principle, moulded in the cement at the ends of the sections. This forms a cheaper construction than the use of full-weight pipe.

**Earthenware Conduits.** This form of conduit is being extensively used for underground cables. The sections may be of the single-duct or multiple-duct type. The former consists of an earthenware pipe from 18 to 24 inches in length. The internal diameter is from  $2\frac{1}{2}$  to 3 inches. These are laid on a bed of concrete, the separate tiles being laid up in concrete in such a manner as to break joints between the various ducts. In the multiple-duct system the joints are wrapped with burlap and the whole embedded in concrete. This form of conduit has a smooth interior and the cables are readily drawn in and out. The single-duct

type lends itself admirably to slight changes of direction that may be necessary. Fig. 38 shows both forms of duct, while Fig. 39 shows a cement-lined iron-pipe duct system, laid in concrete, in course of construction.

Other forms of conduits are ducts formed in concrete, earthenware troughs, cast-iron troughs, and fibre tubes.

**Manholes.** For all drawing-in systems, it is necessary to provide some means of making connections between the several lengths of cable after they are drawn in, as well as for attaching feeders. Since the cables cannot be handled in lengths greater

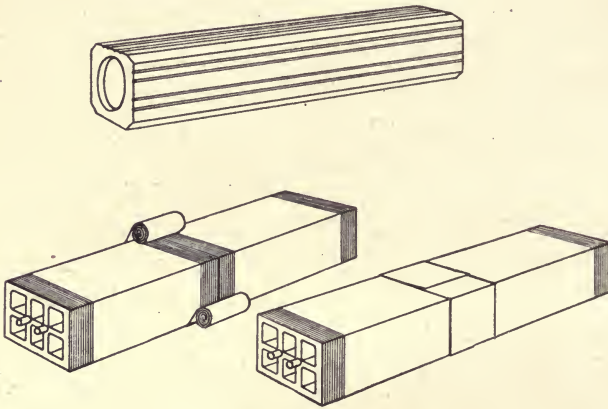

Fig. 38.

than about 500 feet, and less than this in many cases, vaults or junction boxes must be placed at frequent intervals. Such vaults are known as splicing vaults or manholes. The size of the manhole depends upon the number of ducts in the system, as well as on the depth of the conduit. If the ducts be laid but a short distance from the surface of the street and traffic is light, the cables may be readily spliced with a manhole but 4 feet square and 4 feet deep. The smaller vaults are often called "*hand-holes*". Deeper vaults are from 5 to 6 feet square, and the floor should be at least 18 inches below the lowest ducts on account of convenience to the workmen and to serve as collecting basins for water which gets into the system. The ducts should always be laid with a gentle slope toward such manholes.



Common construction consists of a brick wall laid upon a concrete floor, the brick being laid in cement and being coated internally with cement. The cables follow the sides of the manhole and they are supported on hooks set in the brickwork. This causes quite a waste of cable in large manholes. Care should be taken that workmen do not use the cables, so supported, as ladders



Fig. 39.

in entering and leaving the manhole, as the lead sheathing may be readily injured when the cables are so used.

Conductors are drawn into place by the aid of some form of windlass. Special jointed rods, 3 to 4 feet long, may be used for making the first connection between manholes or a steel wire or tape may be pushed through. A rope is drawn into the duct and the cable is attached to this rope. Fig. 40 shows one way in which the cable may be attached to the rope. Care must be taken to see that no sharp bends are made in the cable during this process. Cable should not be drawn in during extremely cold weather unless some means are employed for keeping it warm, owing to the liability of the insulation to be injured by cracking.

Conduit systems must be ventilated in order to prevent explosion due to the collecting of explosive mixtures of gas. Many special ventilating schemes have been tried, but the majority of systems depend for their ventilation on holes in the manhole covers. This prevents excessive amounts of gas from collecting but does not always free the system from gas so completely as to make it safe for workmen to enter the splicing vault until the impure air has been pumped out.

The above applies to the main conduit system. Auxiliary ducts are laid over the main ducts and distribution accomplished from hand-holes in this system.

It is customary to ground the lead sheaths of the cables at frequent intervals, thus in no way depending on the ducts even when made of insulating material, for insulation.

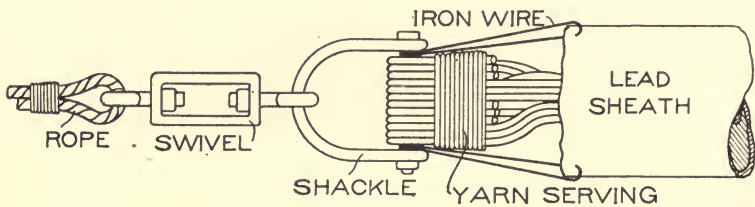

Fig. 40.

**Cables.** Well insulated copper cables are used for underground systems. On account of the fact that various materials, such as acids and oils which are injurious to the insulation, come in contact with the cable, it is necessary that it be protected in some manner. A lead sheath is employed for this purpose. This sheath is made continuous for the whole length of the conductor, and with its use it is possible to employ insulating materials such as paper which, on account of being readily saturated by moisture, could not be used at all without such a hermetically sealed sheath. Lead containing a small percentage of tin is usually employed for this purpose. The sheath may consist of a lead pipe into which the cable is drawn, after which the whole is drawn through suitable dies, bringing the lead in close contact with the insulation or the casing may be formed by means of a hydraulic press.

Yarns thoroughly dried and then saturated with such materials as paraffin, asphaltum, rosin, etc., paper, both dry and saturated,



and rubber are the materials more generally employed for insulation. When paper is employed, it is wound on in strips, the cable being passed through a die after each layer is applied, after which it is dried at a temperature of 200° F to expel moisture. After being immersed in a bath of the saturating compound it is taken to the hydraulic presses where the lead sheath is put on.

When rubber insulation is used, the conductors are tinned to prevent the action of any uncombined sulphur which may be present in the vulcanized rubber. The Hooper process consists of using a layer of pure rubber next to the conductors and using the vulcanized rubber outside of this. One or two layers of pure rubber tape are put on spirally, the spiral being reversed for each layer. Rubber compound in two or more layers is applied over this in the form of two strips which pass between rollers which fold these strips around the core and press the edges together. Prepared rubber tape is applied over this, after which the insulator is vulcanized and the cable tested. If satisfactory the external protection is applied.

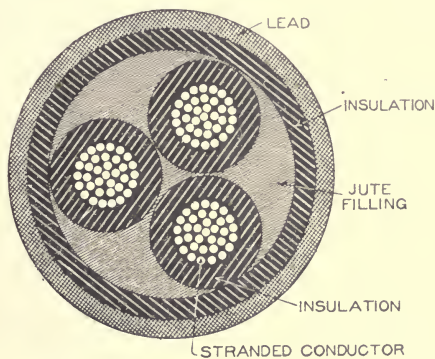

Fig. 41.

Cable for polyphase work is made up of three conductors in one sheath. Fig. 41 shows a cross-section of cable manufactured for three-phase transmission at 6,600 volts. The conductors of this cable have a cross-section equivalent to a number 0000 wire, to which an insulation of rubber  $\frac{6}{32}$ -inch thick is applied. These three conductors are twisted together with a lay of about 20 inches. Jute is used as a filler, and a second layer of rubber insulation  $\frac{4}{32}$ -inch thick is then applied. The lead sheath employed is  $\frac{1}{8}$ -inch thick, and is alloyed with 3% of tin.

Joints in cables must be carefully made. Well-trained men only should be employed. The insulation applied to the joint should be equivalent to the insulation of the cable at other points, and the joint as a whole must be protected by a lead sheath made

continuous with the main covering by means of plumbers' joints.

Some engineers prefer rubber, some paper insulation, but both types are giving good service, and are used up to voltages of 22,000. It is customary to subject each cable to twice its normal potential soon after it is installed. This voltage should not be applied or removed too suddenly as unnecessary strains might be produced in this manner.

Rubber-insulated cables should never be allowed to reach a temperature exceeding 65° to 70° C (149° to 158° F). Paper will stand a temperature of 90° C (194° F), but it is neither desirable nor economical to allow such a temperature to be reached. The following table is of interest in connection with underground cables. The dimensions here given are only general.

**TABLE VIII.**  
**Typical Cable Construction.**

Cables.	No. of Conductors.	Character of Conductor	Sizes of Individual Wires.
Electric light less than 500 volts..	Single	Stranded	No. 10 B.&S. or smaller.
Arc lighting.....	Single	Solid	No. 6 or 4 B.&S.
High-tension power transmission.	Single, concentric, duplex, or three conductors	Stranded	No. 10 B.&S. or smaller.

**Thickness of Insulation.**

	Rubber.	Saturated Fiber.	Saturated Paper.	Dry Paper.	Thickness of Lead.
	Inch.	Inch.	Inch.	Inch.	Inch.
Electric light less than 500 volts.....	$\frac{3}{32}$	$\frac{6}{32}$	$\frac{5}{32}$	$\frac{5}{32}$	$\frac{1}{16}$ to $\frac{1}{10}$
Arc lighting.....	$\frac{5}{32}$ to $\frac{8}{32}$	$\frac{8}{32}$	$\frac{8}{32}$	$\frac{8}{32}$	$\frac{1}{10}$
High-tension power transmission.....	$\frac{5}{32}$ to $\frac{8}{32}$	$\frac{8}{32}$	$\frac{8}{32}$	$\frac{8}{32}$	$\frac{1}{10}$

**Selection of Voltage to be Used.** The voltage to be selected for a given system depends on the distance the power is to be transmitted as well as its amount, and on the use to be made of the power. If a lighting load is concentrated in a small district, a 220-volt three-wire system will give very good service. If the

region is a little more extended, possibly a 440-volt three-wire system using 220-volt lamps would serve the purpose without an excessive loss of power or a prohibitive outlay for copper. For location when the service is scattered, a distribution at from 2,200 to 4,000 volts alternating current is used, transformers being located as required for stepping down the voltage for the units which may be fed from a two- or three-wire secondary system.

2,300 volts (alternating) is a standard voltage for lighting purposes and for polyphase systems; 2,300 volts is often taken as the voltage between the outside wires and the neutral wire of a four-wire three-phase distribution.

For railway work, 550 to 600 volts direct current is used up to distances of about 5 or 6 miles, beyond which it becomes more economical to install an alternating-current main station and supply the line at intervals from substations to which the power is transmitted at voltages of from 6,600 to 30,000 or even higher, depending on the distance it is to be transmitted. At present, the highest voltage used in long-distance transmission is 60,000, though higher values are contemplated. Such voltages are used only on very long lines, and each one becomes a special problem. It is always well to select a voltage for apparatus which may be considered as standard by manufacturing companies, as standard apparatus may always be purchased more cheaply and furnished in shorter time than special machinery.

**Protection of Circuits.** Lightning arresters are installed at intervals along overhead lines for the protection of connected apparatus. For ordinary lighting circuits, such arresters are installed for the protection of transformers, and are located preferably on the first pole away from the one on which the transformer is installed. Care should be taken to see that there are no sharp bends or turns in the ground wire and that there is a good ground connection. For the high-tension lines, lightning arresters at either end of the circuit are relied on to afford the greater part of the protection. In some localities, a wire strung on the same pole line at a short distance from the power wires and grounded at very frequent intervals has been found to reduce troubles due to lightning.

The grounding of the neutral of three-wire secondary systems forms a means of protection of such circuits against high potentials

which might arise from accidental contact with the primaries, and is recommended in some cases. The grounding of the neutral of high-tension systems reduces the potential between the lines and the ground, but a single ground will cause a short-circuit on the line with any grounded system. Grounding, through a resistance which will limit the flow of current in such a short-circuit, has been recommended and is employed in some instances. Spark arresters are installed at the ends of high-tension underground systems to prevent high voltages which might injure the insulation in case of sudden changes in load, grounds, and short-circuits.

# INDEX

---

*Part I*—POWER STATIONS; *Part II*—POWER TRANSMISSION

	Part	Page
All-day efficiency.....	II,	44
Alternating-current line calculation.....	II,	29
examples of.....	II,	39
Alternating-current systems of distribution.....	II,	21
Annunciator wire.....	II,	9
Boiler efficiencies, table.....	I,	13
Boiler foundations.....	I,	22
Boilers.....	I,	10
Cornish.....	I,	11
economic.....	I,	12
Lancashire.....	I,	11
marine.....	I,	11
multitubular.....	I,	11
water-tube.....	I,	11
Boilers, firing of.....	I,	23
Cable, standard, table.....	I,	47
Cable construction, table.....	II,	72
Cables.....	II,	70
Capacity of conductors for carrying current.....	II,	7
Capacity ratios, table.....	I,	61
Central station.....	I,	3
Charging for power, methods of.....	I,	75
Circuits, protection of.....	II,	73
Conductors.....	II,	3
capacity of for carrying current.....	II,	7
for various conditions, table.....	II,	7
Copper losses.....	II,	44
Copper wire table.....	II,	4
Cornish boilers.....	I,	11
Cross-arms.....	II,	56
Curtis turbine.....	I,	27
Direct-current feeder panels.....	I,	50
Distribution systems.....	II,	11
multiple-series.....	II,	17
parallel.....	II,	13
series.....	II,	11
series-multiple.....	II,	17



	Part	Page
Draft		
mechanical.....	I,	23
natural.....	I,	23
Earthenware conduits.....	II,	67
Economic boiler.....	I,	12
Efficiency of transformer.....	II,	44
Electric distribution of power.....	II,	3
Electrical plant.....	I,	36
Engines, gas.....	I,	34
Exciter panels.....	I,	50
Exciters.....	I,	39
Feed water.....	I,	20
Feeding appliances.....	I,	20
Feeding point.....	II,	15
Firing of boilers.....	I,	23
Formula, general wiring.....	II,	30
Frequency, choice of.....	II,	49
Fuel, handling of.....	I,	23
Full load ratios, table.....	I,	61
Galloway boiler.....	I,	11
Gas engines.....	I,	34
Generating station, location of.....	I,	4
Generator efficiencies, table.....	I,	38
Generators.....	I,	36
Governors.....	I,	34
Gutta percha.....	II,	10
Handling of fuel.....	I,	23
Hydraulic plants.....	I,	29
Increase in boiler efficiency, table.....	I,	20
India rubber.....	II,	10
Inductance.....	II,	27
per mile of circuit, table.....	II,	26
Insulation.....	II,	8
Insulators.....	II,	57
Iron or core losses.....	II,	44
Lancashire boilers.....	I,	11
Location of generating station.....	I,	4
Loss of power in steam pipes.....	I,	19
Loss in pressure in steam pipes, formula for.....	I,	18
Manholes.....	II,	68
Marine boilers.....	I,	11
Matthiessen's standard.....	II,	6
Mechanical draft.....	I,	23
Mechanical strength of different materials.....	II,	6
Multiple-series system of distribution.....	II,	17
Multiple wire system.....	II,	18
parallel.....	II,	21
polyphase.....	II,	22

	Part	Page
Multiple wire system		
series.....	II,	21
three-wire.....	II,	18
Multitubular boiler.....	I,	11
Mutual inductance.....	II,	28
Natural draft.....	I,	23
Oil-cooled transformers.....	I,	41
Oil switches.....	I,	52
Overhead lines.....	II,	50
cross-arms.....	II,	56
insulators.....	II,	57
location of.....	II,	51
pins.....	II,	59
stresses sustained by.....	II,	60
supports for.....	II,	52
Panels		
direct-current.....	I,	50
exciter.....	I,	50
total output.....	I,	51
Parallel systems of distribution.....	II,	13, 21
voltage regulation of.....	II,	20
Power factor.....	II,	33
Power station buildings.....	I,	63
Pressure of water, table.....	I,	31
Plant, size of.....	I,	8
Pump log conduit.....	II,	66
Regulation of a transformer.....	II,	45
Resistance, effects of.....	II,	7
Resistance of electrical conductors.....	II,	4
Riveted hydraulic pipe, table.....	I,	32
Safety devices.....	I,	57
Selection of system.....	I,	6
Series system of distribution.....	II,	11
Series-multiple system of distribution.....	II,	17
Size of plant.....	I,	8
Station arrangement.....	I,	68
Station records.....	I,	70
Steam engines.....	I,	25
Steam piping.....	I,	13
arrangement.....	I,	14
material for.....	I,	16
Steam plant.....	I,	10
Steam turbines.....	I,	25
Storage batteries.....	I,	44
Stresses sustained by pole line.....	II,	60
Substations.....	I,	59
Superheated steam.....	I,	19
Switchboards.....	I,	44

	Part	Page
Draft		
mechanical.....	I,	23
natural.....	I,	23
Earthenware conduits.....	II,	67
Economic boiler.....	I,	12
Efficiency of transformer.....	II,	44
Electric distribution of power.....	II,	3
Electrical plant.....	I,	36
Engines, gas.....	I,	34
Exciter panels.....	I,	50
Exciters.....	I,	39
Feed water.....	I,	20
Feeding appliances.....	I,	20
Feeding point.....	II,	15
Firing of boilers.....	I,	23
Formula, general wiring.....	II,	30
Frequency, choice of.....	II,	49
Fuel, handling of.....	I,	23
Full load ratios, table.....	I,	61
Galloway boiler.....	I,	11
Gas engines.....	I,	34
Generating station, location of.....	I,	4
Generator efficiencies, table.....	I,	38
Generators.....	I,	36
Governors.....	I,	34
Gutta percha.....	II,	10
Handling of fuel.....	I,	23
Hydraulic plants.....	I,	29
Increase in boiler efficiency, table.....	I,	20
India rubber.....	II,	10
Inductance.....	II,	27
per mile of circuit, table.....	II,	26
Insulation.....	II,	8
Insulators.....	II,	57
Iron or core losses.....	II,	44
Lancashire boilers.....	I,	11
Location of generating station.....	I,	4
Loss of power in steam pipes.....	I,	19
Loss in pressure in steam pipes, formula for.....	I,	18
Manholes.....	II,	68
Marine boilers.....	I,	11
Matthiessen's standard.....	II,	6
Mechanical draft.....	I,	23
Mechanical strength of different materials.....	II,	6
Multiple-series system of distribution.....	II,	17
Multiple wire system.....	II,	18
parallel.....	II,	21
polyphase.....	II,	22

	Part	Page
Multiple wire system		
series.....	II,	21
three-wire.....	II,	18
Multitubular boiler.....	I,	11
Mutual inductance.....	II,	28
Natural draft.....	I,	23
Oil-cooled transformers.....	I,	41
Oil switches.....	I,	52
Overhead lines.....	II,	50
cross-arms.....	II,	56
insulators.....	II,	57
location of.....	II,	51
pins.....	II,	59
stresses sustained by.....	II,	60
supports for.....	II,	52
Panels		
direct-current.....	I,	50
exciter.....	I,	50
total output.....	I,	51
Parallel systems of distribution.....	II,	13, 21
voltage regulation of.....	II,	20
Power factor.....	II,	33
Power station buildings.....	I,	63
Pressure of water, table.....	I,	31
Plant, size of.....	I,	8
Pump log conduit.....	II,	66
Regulation of a transformer.....	II,	45
Resistance, effects of.....	II,	7
Resistance of electrical conductors.....	II,	4
Riveted hydraulic pipe, table.....	I,	32
Safety devices.....	I,	57
Selection of system.....	I,	6
Series system of distribution.....	II,	11
Series-multiple system of distribution.....	II,	17
Size of plant.....	I,	8
Station arrangement.....	I,	68
Station records.....	I,	70
Steam engines.....	I,	25
Steam piping.....	I,	13
arrangement.....	I,	14
material for.....	I,	16
Steam plant.....	I,	10
Steam turbines.....	I,	25
Storage batteries.....	I,	44
Stresses sustained by pole line.....	II,	60
Substations.....	I,	59
Superheated steam.....	I,	19
Switchboards.....	I,	44

	Part	Page
System, selection of.....	I,	6
Tables		
boiler efficiencies.....	I,	13
boiler efficiency, increase in.....	I,	20
boilers, floor space for.....	I,	12
cable, standard.....	I,	47
cable construction.....	II,	72
capacity in Micro-Farads per mi. of circuit for three phase system.....	II,	25
capacity ratios.....	I,	61
conductors for various conditions.....	II,	7
conductors for various positions.....	II,	8
copper wire.....	II,	4
exciters for single-phase A. C. generators.....	I,	39
full load ratios.....	I,	61
generator efficiencies.....	I,	38
horse-power per cu. ft. of water per min. for different heads....	I,	34
inductance per mile of circuit.....	II,	26
permissible overload 33 per cent.....	I,	9
rate of flow of water, in ft. per min., per pipes of various sizes..	I,	22
resistances of pure aluminum wire.....	II,	5
riveted hydraulic pipe.....	I,	32
temperature effects in spans.....	II,	62
transmission line calculation.....	II,	31
water, pressure of.....	I,	31
wire, standard.....	I,	47
Temperature coefficient.....	II,	6
Three-wire system of distribution.....	II,	18
Total output panels.....	I,	51
Transformer connections.....	II,	46
Transformer regulation.....	II,	45
Transformers.....	I, 40; II,	43
efficiency of.....	II,	44
oil-cooled.....	I,	41
water-cooled.....	I,	42
Transmission lines.....	II,	24
capacity.....	II,	24
Turbines.....	I,	25
Curtis.....	I,	27
steam.....	I,	25
water.....	I,	30
Underground construction.....	II,	63
Crompton system.....	II,	65
Edison tube system.....	II,	63
Siemens-Halske system.....	II,	65
French system.....	II,	65
Underwriter's wire.....	II,	9
Variation in voltage.....	II,	17



	Part	Page
Voltage, selection of.....	II,	72
Voltage regulation of parallel systems.....	II,	20
Water-cooled transformers.....	I,	42
Water-tube boilers.....	I,	11
Water turbines.....	I,	30
Weatherproof wire.....	II,	9
Weight of materials.....	II,	6
Wire, standard, table.....	I,	47
Wiring formula.....	II,	30



# ANNOUNCEMENT OF COMING BOOKS

## PRACTICAL AND SCIENTIFIC

- CARPENTRY.** By G. Townsend. 150 pp., 224 illus. A working manual for Carpenters and Woodworkers in general. Not a theoretical treatise, but a *practical working guide*. Price, **\$1.00**
- GAS ENGINES AND PRODUCERS.** By Marks and Wyer. 150 pp., 90 illus. Latest information in this rapidly developing field. For Engineers, Machinists, Automobilists. Price.....**\$1.00**
- MASONRY CONSTRUCTION.** By Phillips and Byrne. 140 pp., 44 illus. Latest and best American methods. Price.....**\$1.00**
- WATER SUPPLY.** By F. E. Turneaure. 150 pp., 40 illus. An exhaustive compendium for Sanitary and Waterworks Engineers and all interested in matters affecting public health. Price.....**\$1.00**
- HIGHWAY CONSTRUCTION.** By Phillips and Byrne. 140 pp., 80 illus. Modern methods for Road Builders and all interested in better ways of communication. Price.....**\$1.00**
- REINFORCED CONCRETE.** By Webb and Gibson. 150 pp., 140 illus. A manual of practical methods for Architects, Builders, Contractors, Civil and Sanitary Engineers. Information for the first time made known to the world. Based on recent construction work, special tests, etc. Price.....**\$1.00**
- MANAGEMENT OF DYNAMO-ELECTRIC MACHINERY.** By F. B. Crocker. 130 pp., 65 illus. For all who have to do with electric light or power plants. Price.....**\$1.00**
- STEAM ENGINES.** By Leland and Snow. 170 pp., 63 illus. A practical guide. Field covered in a way anyone can grasp. Price.....**\$1.00**
- ELECTRIC RAILWAYS.** By J. R. Cravath. 150 pp., 103 illus. Trolley and third-rail systems, Electric Locomotive, etc. Price.....**\$1.00**
- ESTIMATING.** By Edward Nichols. 140 pp., 35 illus. For all workers in Building trades. Tells how to estimate intelligently. Price.....**\$1.00**
- CONTRACTS AND SPECIFICATIONS.** By James C. Plant. 130 pp., fully illustrated. Forms of public and private contracts, specifications, bonds, etc.; duties and responsibilities of Architects, Contractors, and Owners Price.....**\$1.00**
- STAIR-BUILDING AND STEEL SQUARE.** By Hodgson and Williams. 130 pp., 180 illus. Only up-to-date work on these subjects. Price.....**\$1.00**
- VALVE GEARS AND INDICATORS.** By Leland and Dow. 150 pp., 105 illus. Two books in one. Types of valves, gears, etc., fully explained. Price.....**\$1.00**
- STRENGTH OF MATERIALS.** By E. R. Maurer. 140 pp., 58 illus. For Architects, Builders, Steel and Concrete Workers. Enables one to avoid mistakes. Price.....**\$1.00**
- THE ELECTRIC TELEGRAPH.** By Thom and Collins. 150 pp., 81 illus. Carries along by easy steps to complete mastery. Multiplex and Wireless telegraph explained. Price.....**\$1.00**
- MECHANICAL DRAWING.** By E. Kenison. 160 pp., 140 illus. Complete course in projections, shade lines, intersections and developments, lettering, with exercises and plates. Price.....**\$1.00**
- POWER STATIONS AND TRANSMISSION.** By G. C. Shaad. 160 pp., 43 illus. For Electrical Workers. Up-to-date practice. Price **\$1.00**
- PATTERN MAKING.** By James Ritchey. 150 pp., 250 illus. For Wood and Metal Workers and Molders. Methods of building up and finishing, fully described. Price.....**\$1.00**
- SURVEYING.** By Alfred E. Phillips. 200 pp., 133 illus. For Civil Engineers and Students. All details of field work explained. Price **\$1.50**
- STEEL CONSTRUCTION.** By E. A. TUCKER. 300 pp., 275 illus. Covers every phase of the use of steel in structural work. Based on actual experience, special tests, etc. For Architects, Bridge Builders, Contractors, Civil Engineers. Price.....**\$1.50**
- BUILDING SUPERINTENDENCE.** By E. Nichols. 200 pp., 250 illus. Costly mistakes occur through lack of attention at proper time, hurtful to Owner and discreditable to Architect and Builder. Gives thorough knowledge of methods and materials. Price.....**\$1.50**
- ARCHITECTURAL DRAWING AND LETTERING.** By Bourne, von Holst and Brown. 200 pp., 55 drawings. Complete course in making working drawings and artistic lettering for architectural purposes. Price.....**\$1.50**
- MACHINE SHOP WORK.** By F. W. Turner. 200 pp., 200 illus. Meets every requirement of the shopman, from the simplest tools to the most complex turning and milling machines. Price.....**\$1.50**
- TOOL MAKING.** By E. R. Markham. 200 pp., 325 illus. How to make, how to use tools. Profusely illustrated. Price.....**\$1.50**
- MACHINE DESIGN.** By C. L. Griffin. 200 pp., 82 designs. Written by one of the foremost authorities of the day. Every illustration represents a new device in machine shop practice. Price.....**\$1.50**

These volumes are handsomely bound in red art Vellum de Luxe, size 6½ x 9½ inches. Sent prepaid to any part of the world, on receipt of price. Remit by Draft, Postal Order, Express Order, or Registered Letter.

2B









**THIS BOOK IS DUE ON THE LAST DATE  
STAMPED BELOW**

**AN INITIAL FINE OF 25 CENTS**

**WILL BE ASSESSED FOR FAILURE TO RETURN  
THIS BOOK ON THE DATE DUE. THE PENALTY  
WILL INCREASE TO 50 CENTS ON THE FOURTH  
DAY AND TO \$1.00 ON THE SEVENTH DAY  
OVERDUE.**

**SEP 28 1939**

**SEP 29 1939**

**10 JUL 52 HW**

**JUL 1 6 1952 LU**

179766

TK

1191

A5

**THE UNIVERSITY OF CALIFORNIA LIBRARY**

