

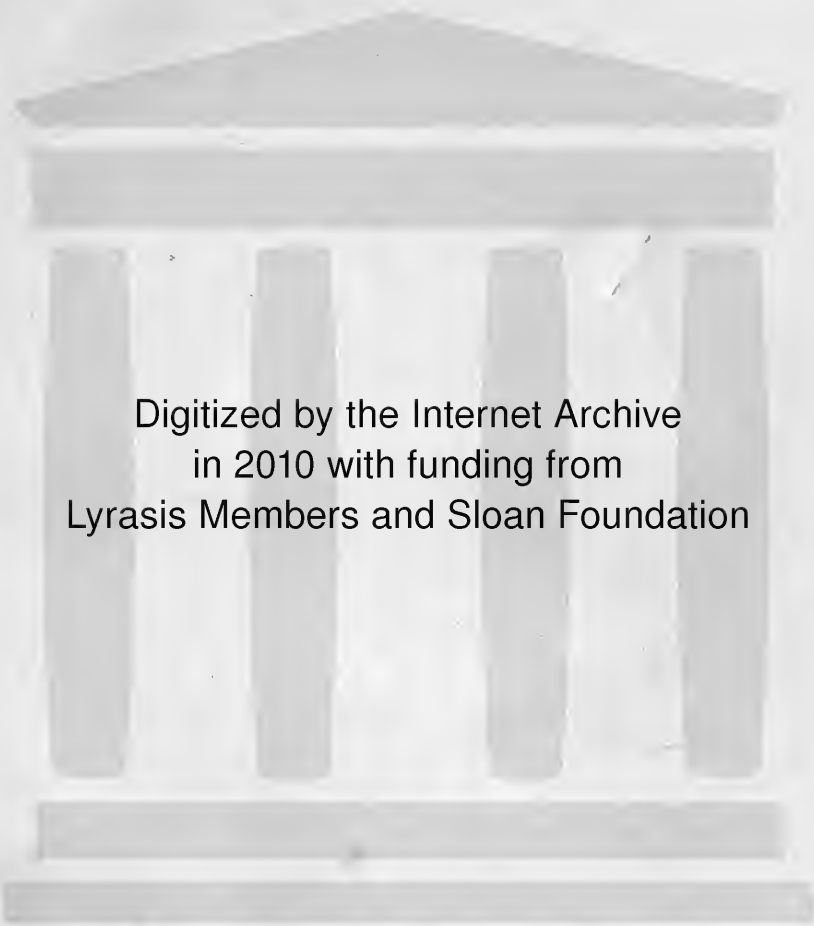

* CLASS 11-200
BOOK 11-200



Digitized by the Internet Archive
in 2010 with funding from
Lyrasis Members and Sloan Foundation

<http://www.archive.org/details/practicalbuilder00pain>

$\frac{1}{2}, 12$ 105

PROCESSED BY
BARROW LAB
10/25, 1977
LOT # 1146

T H E

PRACTICAL BUILDER,

O R

WORKMAN'S GENERAL ASSISTANT:

Shewing the most approved and easy METHODS for DRAWING and WORKING the whole or separate PART of any BUILDING, as

The Use of the TRAMEL for GROINS, ANGLE-BRACKETS, NICHES, &c.

Semi-circular ARCHES on Flying JAMBS, the preparing and making their SOFFITS.

RULES OF CARPENTRY;

To find the LENGTH and BACKING of HIPS, strait or curved; TRUSSES for ROOFS, DOMES, &c.—Trussing of GIRDERS, SECTIONS of FLOORS, &c.

The Proportion of the Five Orders, in their general and particular Parts, Gluing of Columns, STAIR-CASES with their *ramp* and *twist* RAILS, fixing the CARRIAGES, NEWELS, &c.

Frontispieces, Chimney-Pieces, Ceilings, Cornices, Architraves, &c. in the newest Taste.

With Plans and Elevations of Gentlemens and Farm-Houses, Yards, Barns, &c.

By WILLIAM PAIN, ARCHITECT and JOINER.

Engraved on Eighty-three PLATES.

LONDON: PRINTED for I. TAYLOR, at the BIBLE and CROWN, in HOLBORN, near CHANCERY-LANE,
MDCCLXXIV.

**

NA

2515

P185

1774

sl-1

VIRGINIA

AUG 25 1961

STATE LIBRARY

P R E F A C E.

COnsidering the Number of Books on the Theory and Practice of Architecture already published, any further Effort to illustrate and familiarize this MOST NOBLE ART, may seem superfluous and unnecessary; in me especially, who, by two former Publications, endeavoured to advance the young Practitioner in the Knowledge of his Profession.

But as Art is improving, greater Experience enables to discern the truly useful, and thereby to confirm or reject former Methods.

The very great Revolution (as I may say) which of late has so generally prevailed in the Stile of Architecture, especially in the decorative and ornamental Department, will evince the Necessity and eminent Utility of this Publication. That Taste (so conspicuous in our modern Buildings) which is vainly sought in any other practical Treatise, the Workman will here find illustrated in a great Variety of useful and elegant Examples.

The Deficiencies and confined Plans of those Books now used by Workmen, is another Inducement to collect together in one View, the most easy and certain Rules to carry on the Building Art. These are the Result of Experience, and by the Author long used in conducting Business, who now offers the Public a general practical Treatise, wherein his great Care has been plainly and faithfully to answer the Purpose of the manual Artificer: It is not meant to instruct the professed Artist, but to furnish the Ignorant, the Uninstructed, with such a comprehensive System of Practice, as may lay a Foundation for their Improvement, and thereby enable them to execute with Ease and Precision, the various Branches of the Profession.

TABLE OF CONTENTS.

Plate

- 1 — NICHES, Ellipsis, raising Perpendiculars, use of the Trammel, and how to make ditto, &c.
- 2 — Plan and Section of Groins, veneering Niches, &c.
- 3 — Circular Arches in a circular Wall, circle Arches, Soffits, &c.
- 4 — Groins, Angle Brackets, Circular and skewing Soffits
- 5 to 9 Sections of Floors, Trussing Roofs in Ledge, Girders, length and backing of Hips, strait and curved Trusses for Roofs, Domes, &c.
- 10 — Mouldings, Ballasters, &c.
- 11 — Inter Columnations
- 12 — Proportions of the Orders, Pedestals, &c.
- 13 — Tuscan Frontispiece, Base, Capital and Entablature
- 14 — Doric ditto
- 15 — Ditto Entablature at large
- 16 — Ionic Frontispiece, Base, Capital and Entablature
- 17 — Ditto Entablature at large
- 18 — Modern Ionic Capitals and Volute at large
- 19 — Gluing up ditto
- 20 — Antique Ionic Capital

Plate

- 21 — Corinthian Pedestal and Base at large
- 22 — Corinthian Capital and composed ditto
- 23 — Ditto Entablature
- 24 — Antique Composite Capital.
- 25 — Composite Cap & Entablature
- 26 — Planceers of Corners
- 27 — Gluing of Columns
- 28 — Impost
- 29 to 34 Frontispieces with their Entablatures, Moulding, &c.
- 35 & 36 Open Pediments and raking Cornices
- 37 to 48 Chimney-Pieces with their Moulding and Ornaments
- 49 — Mouldings for Pictures and Glass frames
- 50 — Ornaments for Friezes, Pillasters, &c.
- 51 — Cornices for Doors, Chimnies, &c.
- 52 to 58 Bases, Sub-bases, Architraves &c.
- 59 to 61 Cornices for Door-Caps, Chimney-Caps, Rooms, &c.
- 62 to 65 Ceilings, Frets, Guilloches, &c.
- 66 to 73 Stair-Cases
- 74 to 83 Gentlemens Houses, Greenhouses, Hot-houses, Stabling, Farm-houses, &c.

A TABLE for the Cutting of Timber for Building.

Bearing Post.

Height.	
If 8 Feet	9 Inch. square
— 10 —	10 by 9
— 12 —	11 — 12
— 16 —	14 — 15
— 20 —	16 — 18

Beams or Ties.

Length	Inches
12 Feet	7 by 8
16 —	8 — 9
20 —	9 — 10
30 —	10 — 11
40 —	12 — 11
50 —	13 — 12

Girder's Bearing.

If 10 Feet	10 by 9 In.
— 12 —	11 — 10
— 14 —	12 — 11
— 16 —	12 — 13
— 18 —	13 — 14
— 20 —	15 — 14
— 24 —	15 — 16
— 30 —	16 — 18

Small Rafters.

Bearing	Inches
8 Feet	5 by 3
10 —	7 — 3
12 —	8 — 4

Binding Joists.

Bearing	Inches
6 Feet	6 by 4
8 —	7 — 4
9 —	8 — 4
12 —	10 — 5

Principal Rafters.

Length	Bot ^m . Top. Thick.
From 12 to 16 Feet	8 — 6 — 5
From 16 to 20 —	9 — 7 — 6
From 23 to 24 —	10 — 8 — 7
From 24 to 30 —	12 — 10 — 9

Bridging Joists.

Whose Bearing should not exceed 5 Feet,
and Scantling not less than 6 by 4.

Purlins from 8 by 5 to 9 by 7 or 10 by 8.

Raifing Plates from 7 by 5 to 8 by 6, or
10 by 8.

Ground-fills the same as Raifing Plates.

Common Joist.

Bearing	Inches
6 Feet	6 by 3
9 —	9 — 3
12 —	12 — 4

To face P L A T E I.

Figure *A* and *B* are ribb'd NICHES for Plaistering.

THE Plan *a* is a Semi-Elipsis on the transverse Diameter, which is drawn with a Trammel as represented in the Plan, which is to be made with a Grove at Right Angles as in the Figure; two Pieces to be morticed to slip on the Rod, and one fixed at the End for a Pencil, &c. fix one of the Pieces equal to half the Conjugate Diameter, and the other to half the Transverse Diameter, and moving the Rod with the Pins in the Groves, the Pencil will describe the Semi-Elipsis.

To draw the Elipsis *c* to any given Length and Breadth, take half the Conjugate Diameter *a b* and set it on the Transverse Diameter *d c* divide *c a* into three equal Parts, and make *c e* equal to one of those Parts, and with the Radius *e f* bisect *g g*. So the Points *e f* and *g g* are the Centres for drawing the Elipsis to any Length and Breadth.

To draw the Elipsis *d* with a Line, take half the Transverse Diameter *b a* and set it from *c* on the Conjugate Diameter to *d* on the Transverse Diameter, and to *e* on ditto, then *e d* are the Points to be fixed for the Line to go round, which will describe the Elipsis with the Point *f*.

To glue the Head of a Nich as Figure *e*, cut the Arch Part of the Board or Stave to the Thickness of a Veneer, and bend it on a Templet, and back it to the Curve, it may be jointed the same as a Column, &c.

To describe a Polygon to a given Side from five to eight Sides, make a Radius of the given Side for the Pentagon, divide the Arch into five Parts, turn one down on the Line which is the Centre, to describe a Circle which will contain the Side five Times.

For a Hexagon, the Radius of the Side is the Centre.

The Heptagon into seven Parts and turn one up.

The Octagon into four and turn one up.

To raise a Perpendicular at the End or Middle of a Line. Describe the Arch *c d*, and with the Radius *a c* make *e f*, which bisect at *b*, gives the Perpendicular to *a*.

To let fall a Perpendicular from a given Point to a Base Line. Figure *G*; let *a* be the Point given to fall to the Base Line *b c*, draw a right Line from *a* at pleasure to meet the Base Line as at *c*, more or less; divide the Line *c a* into two Parts, and draw the Semi-Circle *a b c*, and where the Circle cuts the Base Line at *b*, which is at Right Angles with *a*, which was to be done.

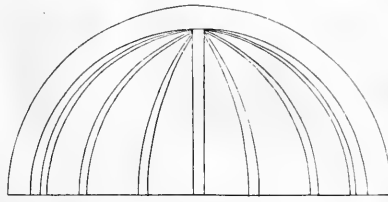
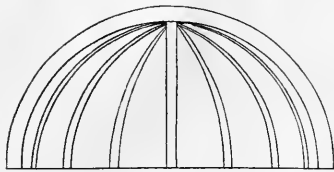

The Trammel Rod

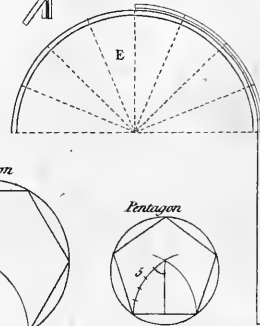
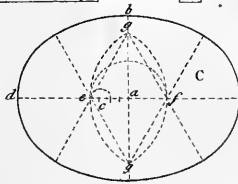
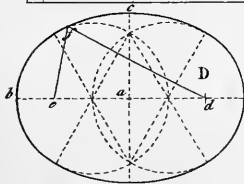
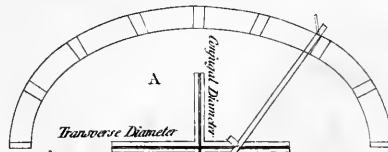
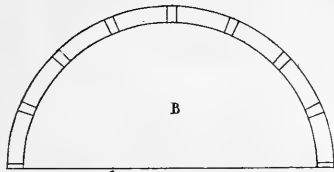

Octagon

Hexagon

Hexagon

Pentagon

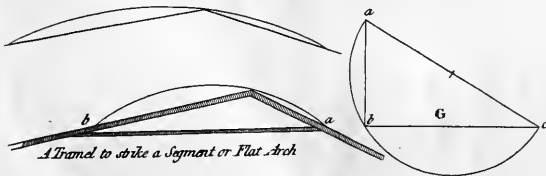
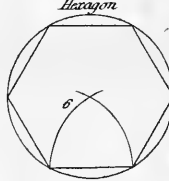
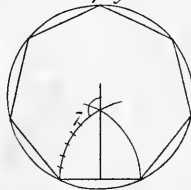
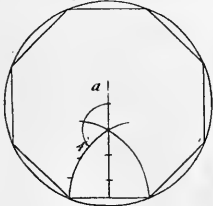

A Trammel to strike a Segment or Flat Arch

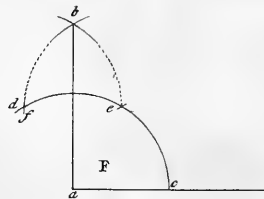

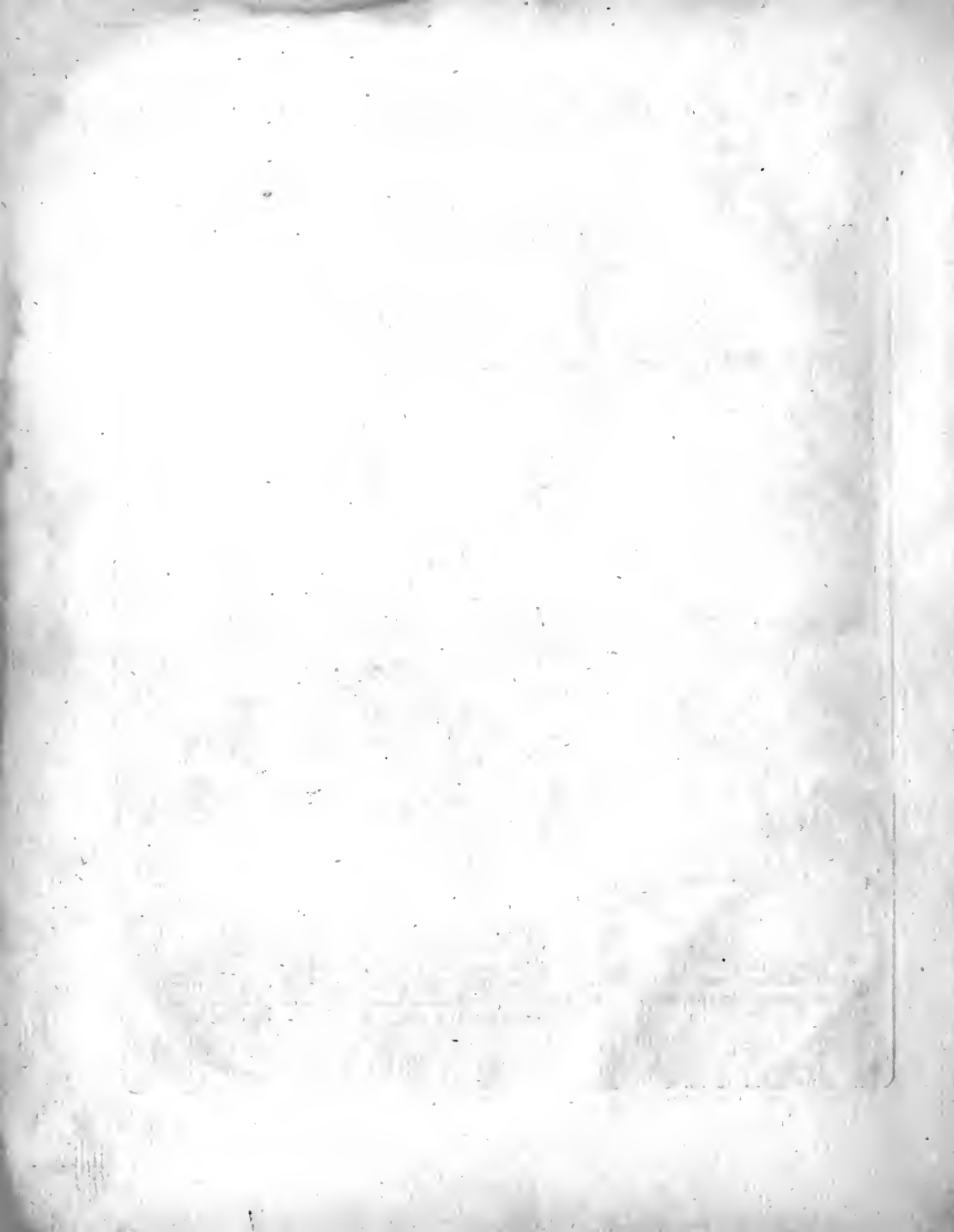

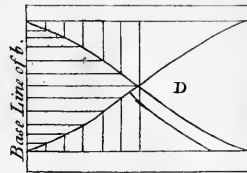
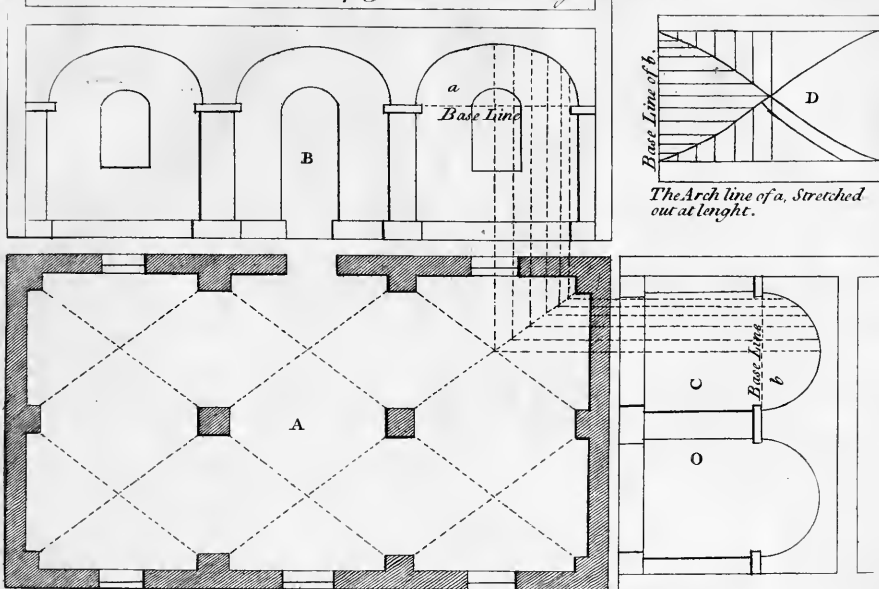

The Arch line of a, Stretched out at length.

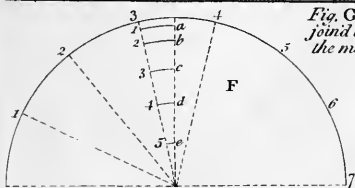
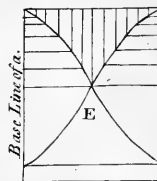
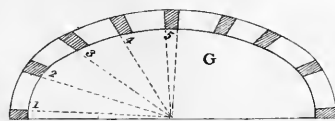

Fig. G, is a Ribbed Niche for plaistering the Ribs all join'd to y place where to stand the Edges are: Bevel so the mould must be shifted.



The arch line of b, Stretched out at length.

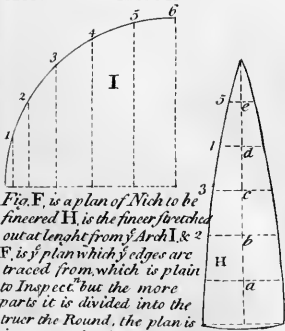

Fig. F, is a plan of Niche to be finccred H, is the finccer stretched out at length from y Arch I, & 2 F, is y plan which y edges are traced from, which is plain to Inspect but the more parts it is divided into the truer the Round, the plan is in 7 parts but in practice it may be into 15 parts or more at pleasure.

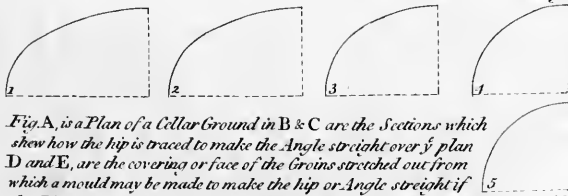
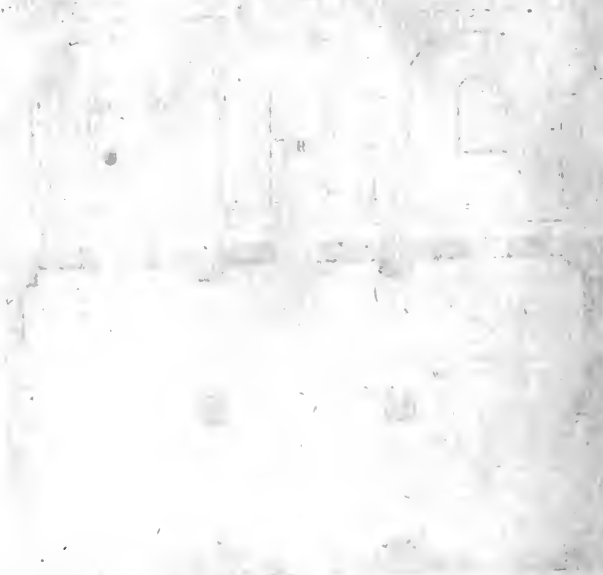

Fig. A, is a Plan of a Cellar Ground in B & C are the Sections which show how the hip is traced to make the Angle straight over y plan D and E, are the covering or face of the Groins stretched out from which a mould may be made to make the hip or Angle streight if the Ribs C, O, are set first & boarded in the mould must be taken from E, but if the Arches in Section B, be set first the mould must be taken from D.

Handwritten text at the top of the page, possibly a title or header.



Handwritten text in the lower left section of the page.

Handwritten text in the lower right section of the page, enclosed in a rectangular border.

Fig. B. is an Arch standing on Flaming Jambs in a Straight Wall and supposed to be a fair Arch in Stone or Brick. Divide the Round of the Arch in as many Parts as are Courses to Complet the Arch and drop them to the Wall Line, then Draw them cross the Wall, Parallel with the Jambs, and that shews how much is to be Cut of the Face of each Course.

*Circular, Arches &c.
in a Circular Wall.*

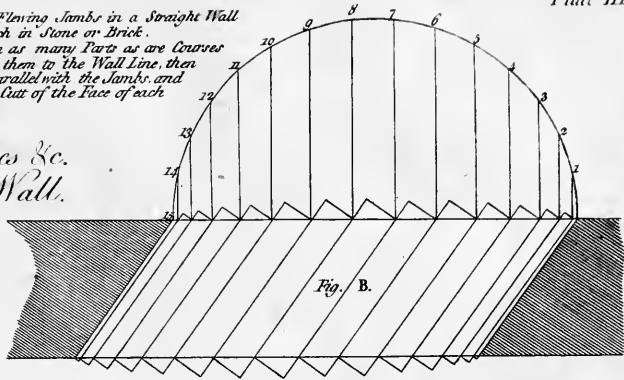

Fig. B.

Fig. A. is a Circular Wall which has a Door or Window that stands Flaming. Because the Jambs do not stand at Right Angles with the Diameter of the Circle, as in Plate IV find the Curve Line of the Soffit in this Case draw the Cord Line or Base Line of the Arch o, g at Right Angles with the Jambs o, k to touch the Arch of the Wall at a, and Divide the Arch into equal Parts and drop them to the Wall then take of the Distances, h, g, d, g, f, f, e, &c. and put them on the Arch so and out. Gives the edge of the Soffit.

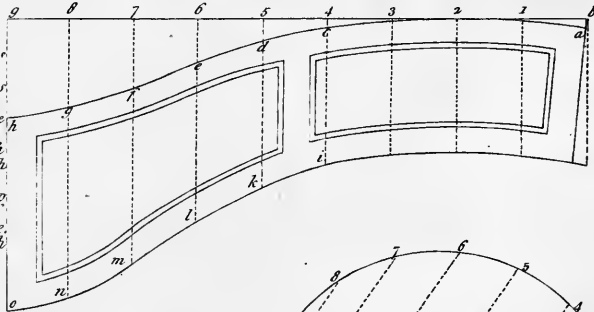
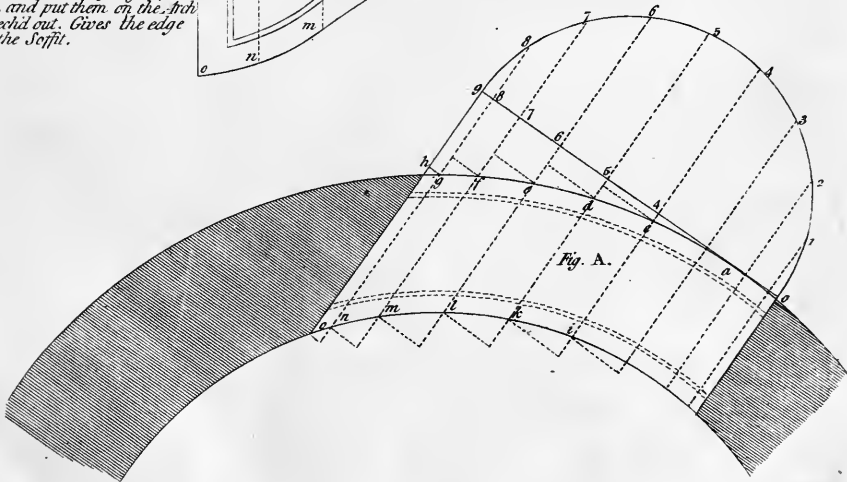

Fig. A.





TO THE HONORABLE SENATE

OF THE STATE OF NEW YORK

IN SENATE, January 15, 1884.

REPORT

OF THE

COMMISSIONERS OF THE LAND OFFICE

IN ANSWER TO A RESOLUTION PASSED BY THE SENATE, APRIL 15, 1883.

ALBANY:

WILEY & SON, PRINTERS, 1884.

NEW YORK:

WILEY & SON, PRINTERS, 1884.

To face P L A T E IV.

Figure *A* is a P L A N to be G R O I N ' D.

DIVIDE the Base Line *a* of the given Rib into equal Parts, and that of *d* into the same Number of Parts, and draw Lines to the Arch Line of *a*, and likewise in *d* at pleasure; then take 1, 2, 3, 4, 5, 6, &c. from *a*, and transfer them to *d*, as 1, 2, 3, 4, 5, 6, &c. and thro' the Point 1, 2, 4, 6, 8; trace the Arch Line over *d*, and so for the Rest, as is plain to Inspection. The Angle Bracket is done in the same Manner.

To describe a Circular Soffit in a Circular Wall, as in *B*. Draw the Cord Line of the Arch, or Base Line so called, to touch the Arch of the Wall, then draw the Semi-Circle and divide the Round of it in a Number of equal Parts as here into 9, but the more Parts the truer the Work, and draw them to the Arch of the Wall, then stretch out the Arch Line at Length as in *e*, and transfer the Parts that are between the Wall and Base Line, as 1, 2, 3, 4, 5, 6, &c. to *e*, which gives the Edge of the Soffit or Pannel.

To describe a Circular Soffit in a frait Wall on flewing Jambes. Continue the flewing of the Wall till it meets at *b*, then set the Compasses at *b*, and draw two Arches to the Thickness of the Wall, then put on the Girt of the Soffit *c d*, which gives the Length of the Soffit and Edge of ditto.

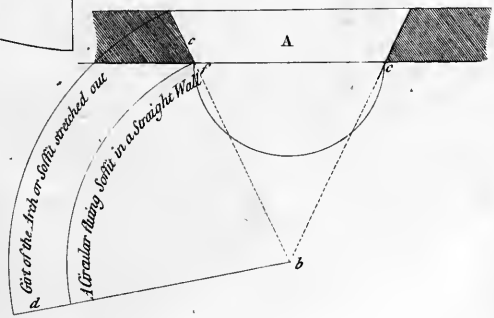
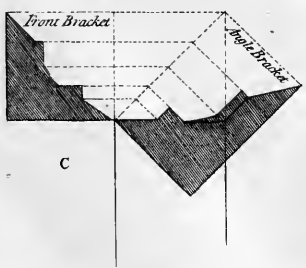
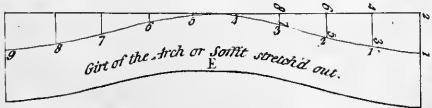
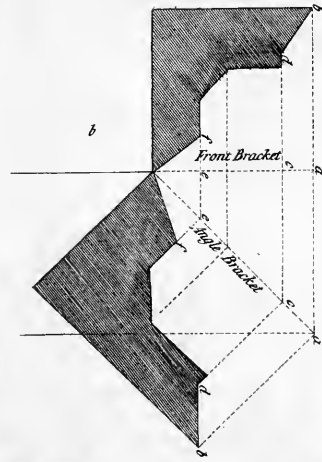
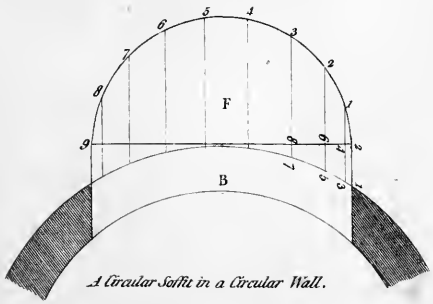
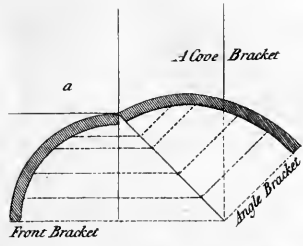
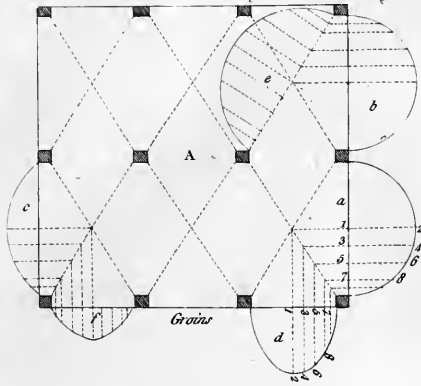



Trussing Girders Floors &c.

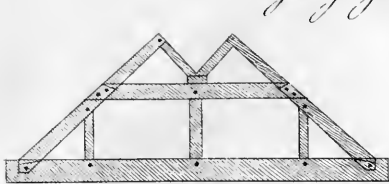

The Dovetail to have one Inch and Quarter Drift on each Side the Beam.

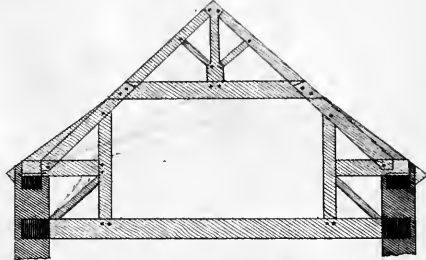

The Girder to be Cut one Inch Camber in 20 Foot &c. notwithstanding they are to be Trussid



The Truss to be of Dry Oak about 4 inches Square, to have Iron Plates at the Ends & Meetings.



Truss Partition

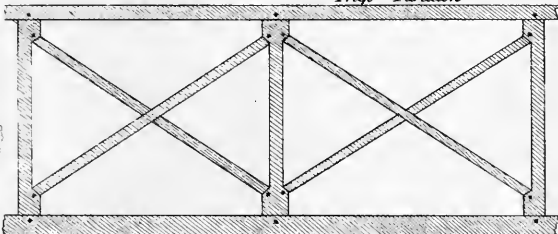
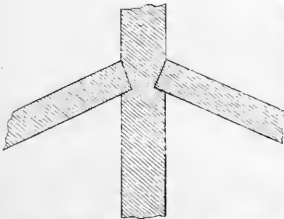

Girder

Girder



Binding Joist

Section of a Bridge Floor



Binding Joist

Section of a Floor with the Binding Joist the whole Depth.



Binding Joist

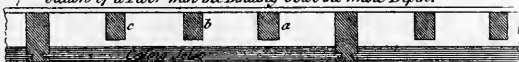

Binding Joist

Note. All Floors that are more than a Foot in Depth should be Bridgal

with three Joints in the interval between the Binding fram'd into the Girders the same way with Binding Joints but not so Deep as ditto as a. b. c. &c.

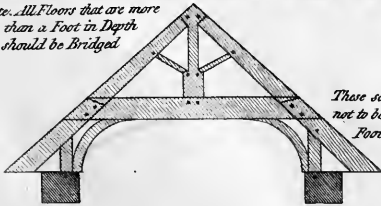

These sort of Floors not to be more than a Foot in Depth

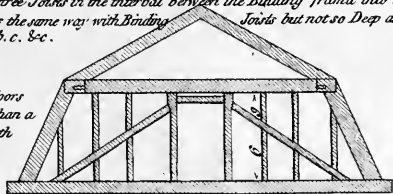

Curb Roof.

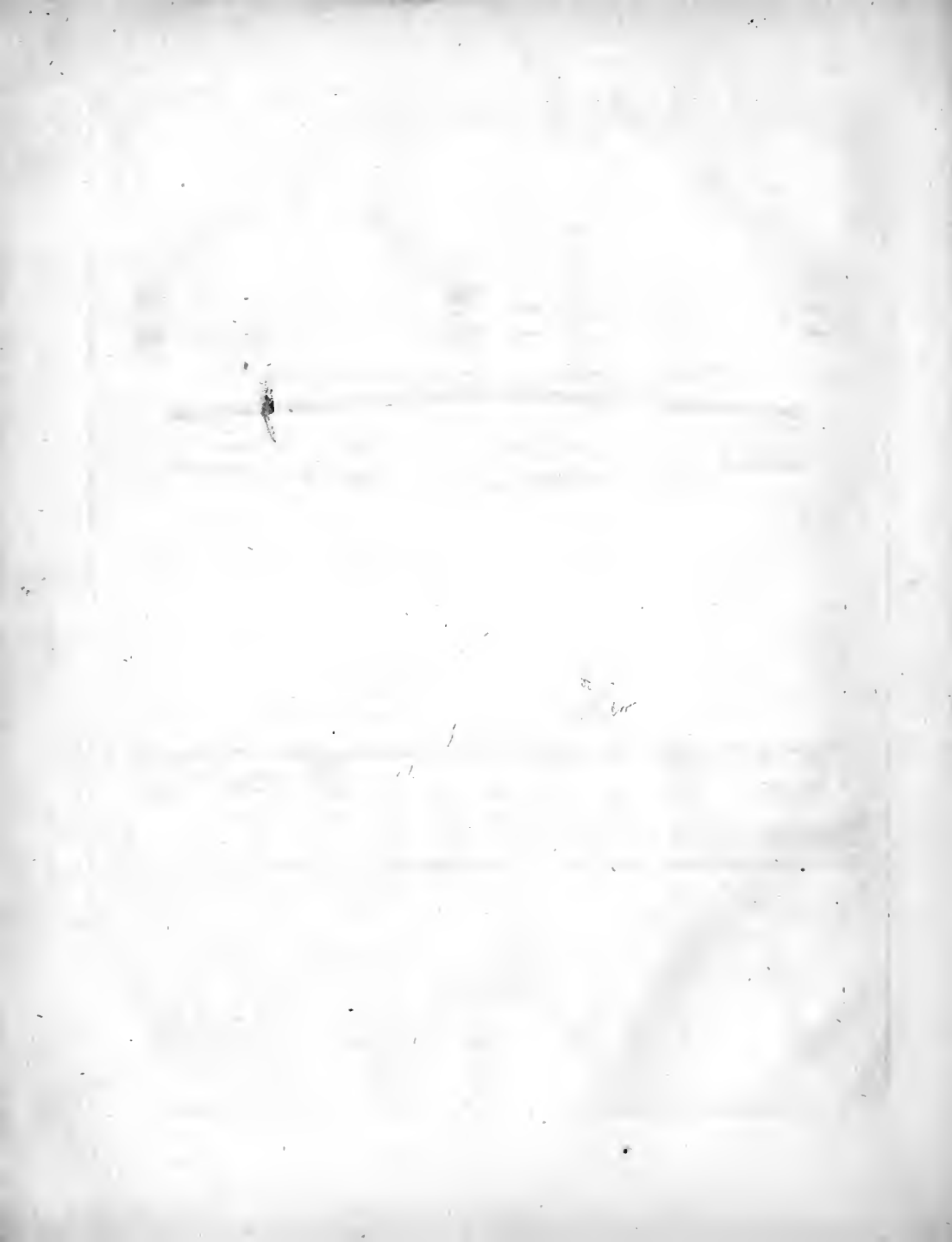

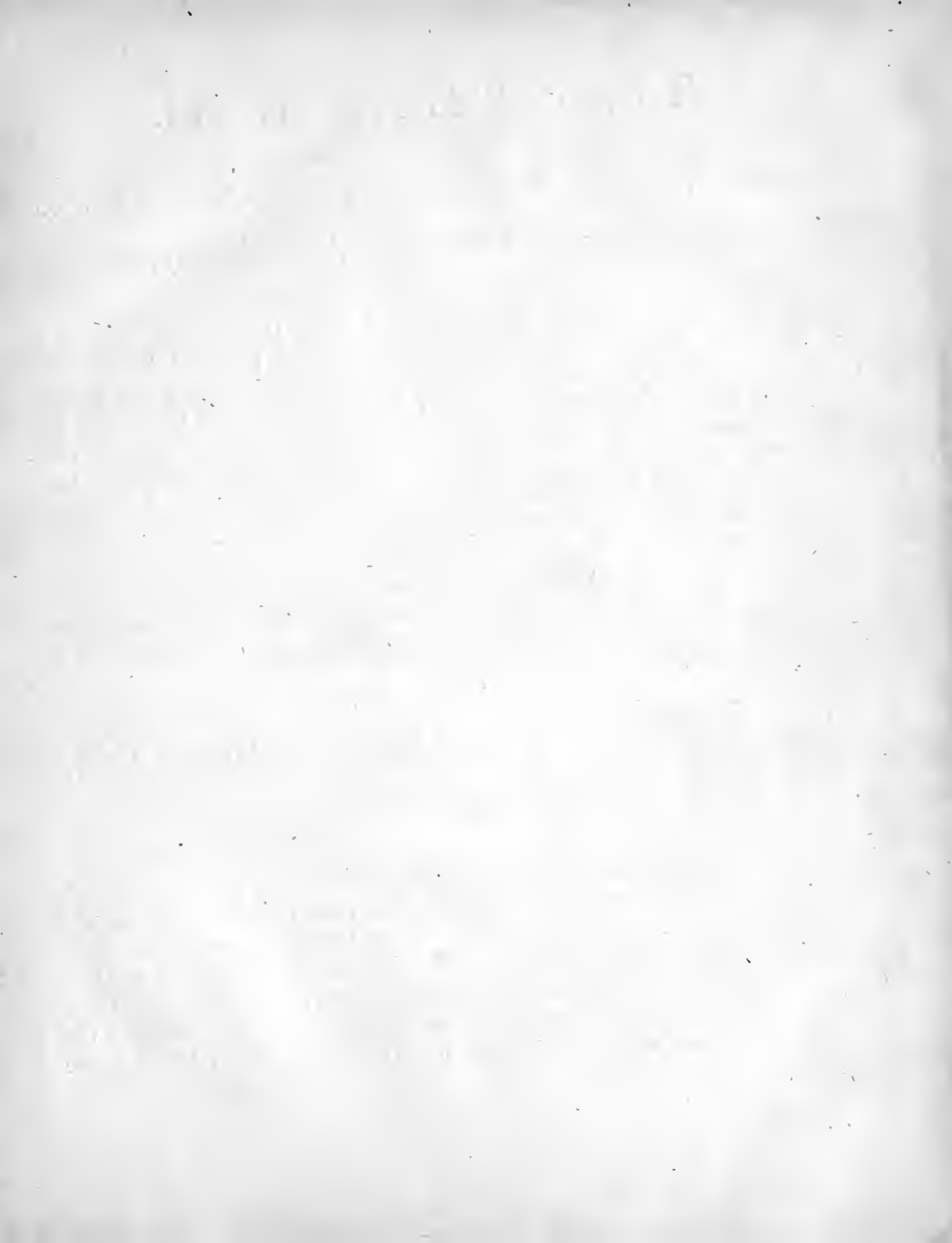

To face P L A T E VI.

Figure *A*. Plan and Ledgment of a Roof, shewing how to find the Length and Backing of Hips, Valley, &c.

TO find the Length, take the Base Line of the Hips *ab*, *bc*, and *be*, and set them on the Base Line of the principal Rafters, as *ba*, *bc*, *be*, and draw Lines from the Top of the Rafter to *ace*, which is the Length of each Hip. Or the Length may be found by setting up the Perpendicular from the Base Line of the Hips, as *bg*, and draw the Line *ga*, is the Length of the Hip. To Back the Hip, lay down the Thickness of the Hip at the Angle of the Plan, as *H*, and draw Lines to range the Plates, will shew how much Wood is to come off in the Backing; that is, the Mould must be a Piece of Wood as thick as the intended Hip, and cut it to the Splay or Pitch of the Hip at the Foot, setting it on the Angle of the Plate in the Direction of the Hip, mark it under by the Side of the Plate; gives the true Backing in any Case required. A very sure and safe Way for the Backing.

Figure *B* is the Plan of an M Roof, with Hip and Valley in Ledgment, &c.

Note, The Back of the Hip is found another Way, as in the Plan *A*. by drawing a Line at Right Angles, cross the Base Line of the Hip, as *rdg*, or on any Part of the Base Line, and set one Foot of the Compass at *d*, and extend to the nearest Part of the Hip *ga*, and turn it on the Base Line, as at *r*, then draw the Lines from the Point *r* to *gr*, on the Edge of the Plate, which is the Backing of the Hip required. This will do in any Case, square or bevel.

Plan of Laidment of Roofs.

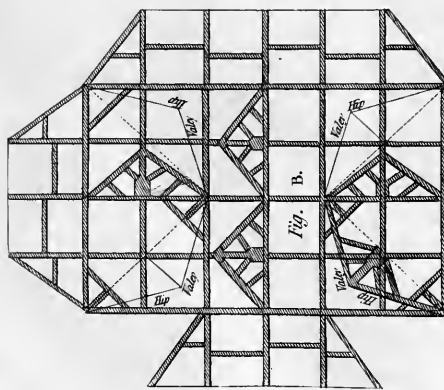
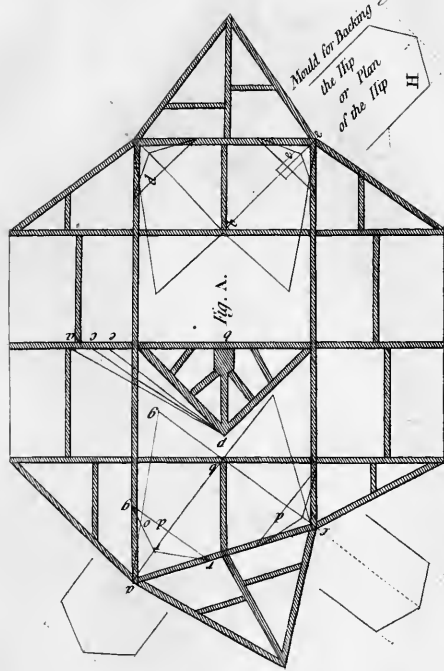

Two Roofs in Laidment shewing how to find the Lengths and Backing of Rafts

Square or Board in any Case required

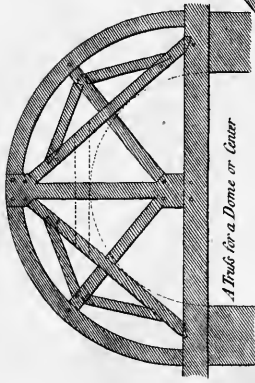
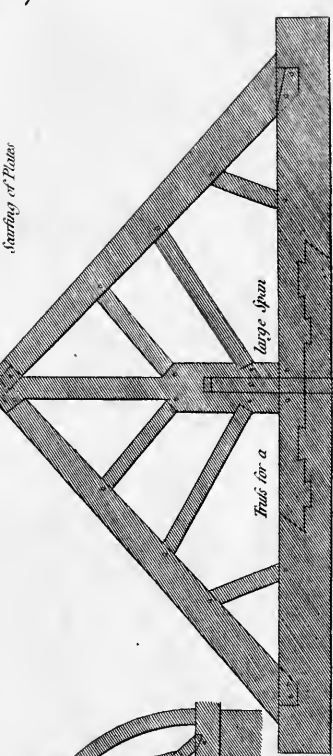
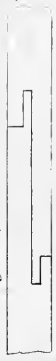

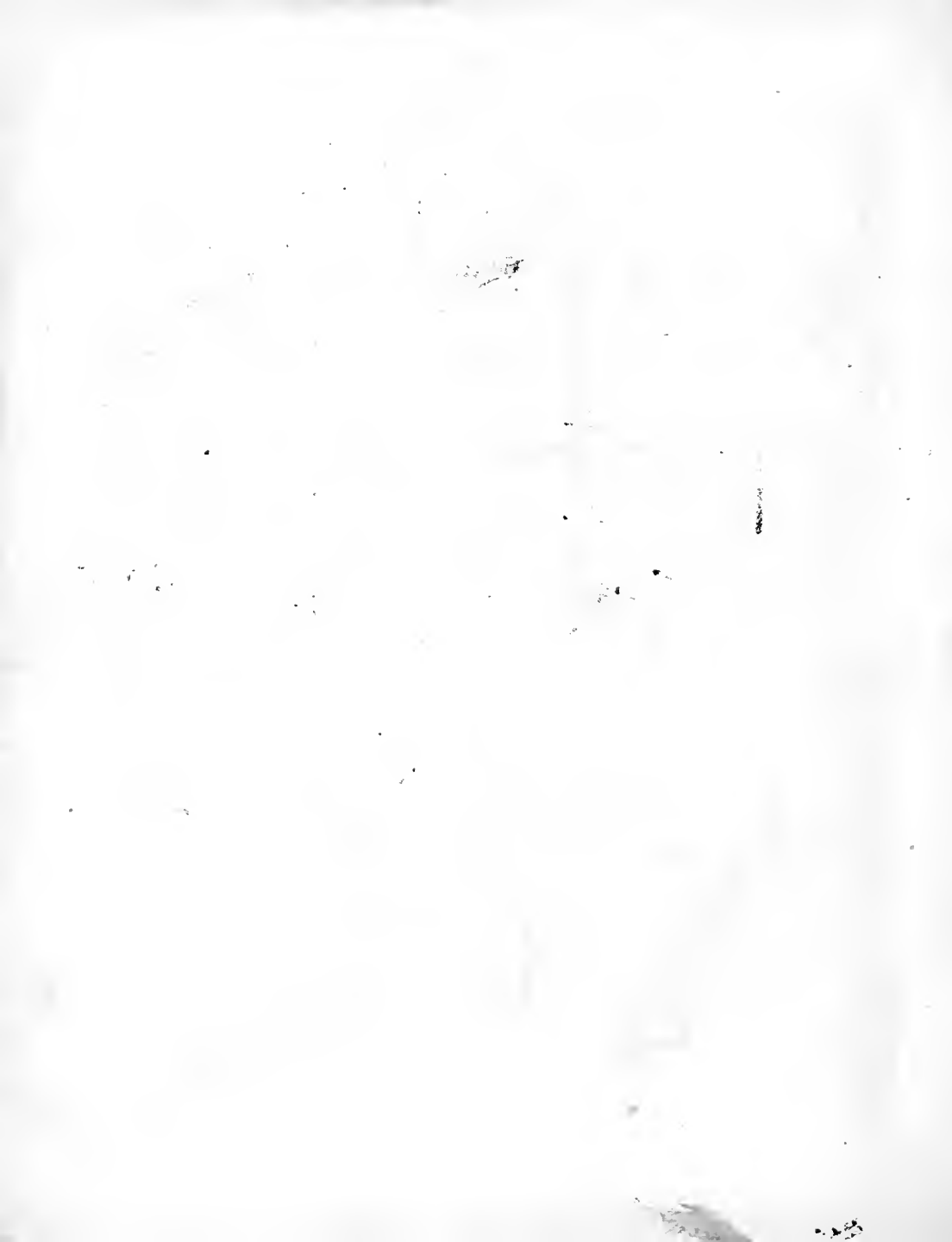

Five different Trusses for Roofs.

Plate VII.

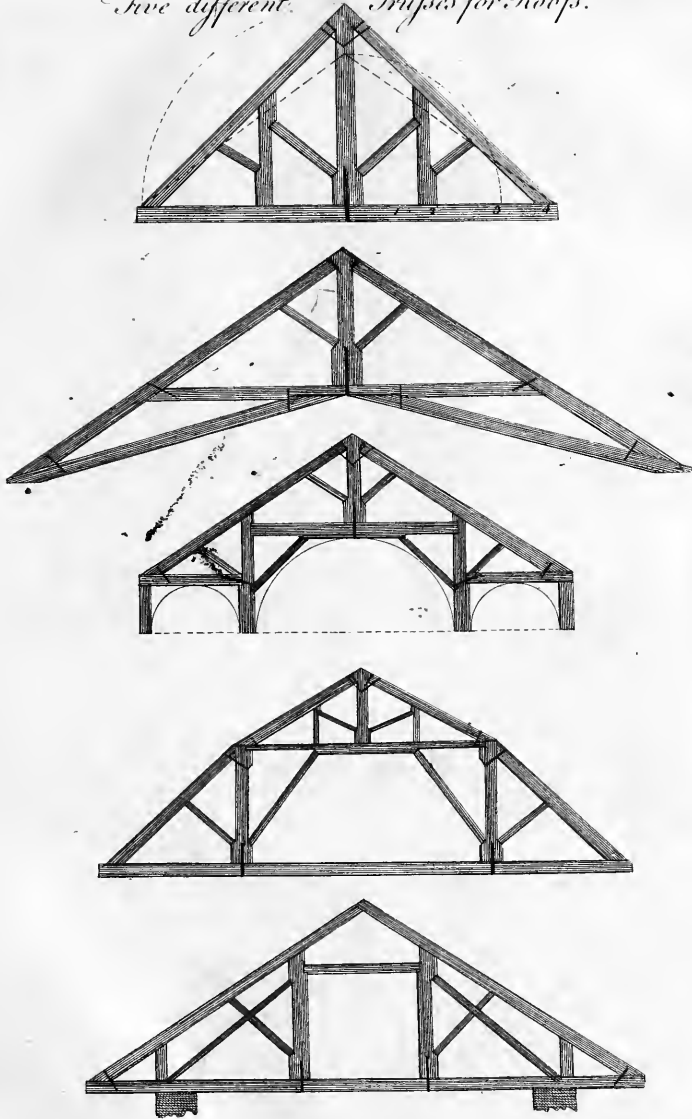



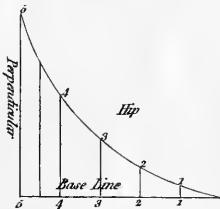
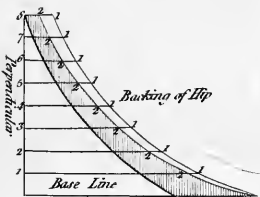
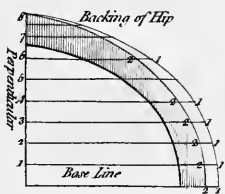
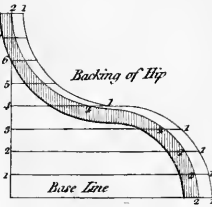
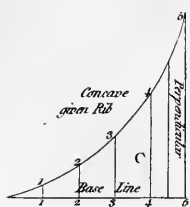
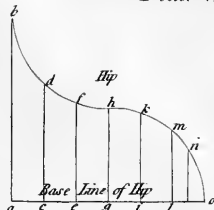
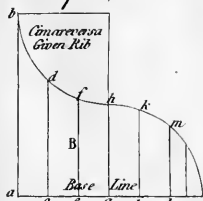
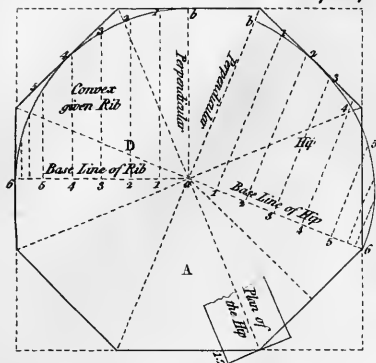

The manner of finding the Length and Backing of Curve Line Hips in any Case required. Suppose the Octagon, Plan Δ , to be Roof'd with the Convex aB , or the Concave C , or the Convex D , in the Plan. Divide the Base Line of the given Rib into any number of equal Parts and draw Lines from those parts on the Base Line to the Back of the Rafter, ab, cd, ef, gh, ik, lm , and all the others as $1, 2, 3, 4, 5, 6, 7, 8, 9, 10$. Then the Base Line of the Hips must be divided into the same number of Parts and Lines drawn up at Pleasure as $a, b, c, d, e, f, g, h, i, k, l, m$ from the Base Line of the Hips, then take the several Heights of the given Ribs and set them on the Hip Lines; then draw them through those Points i, d, f, h, k, m, n, o , that will give the Curve or Edge of the Hip and the same for all the others and for the Backing of the said Hips, there is a Plan of the Hip at the Angle of the Plan Δ , which shows how much Wood is to be Cut off each side of the Hip. Divide the Perpendicular Height of the Hips into any number of equal Parts, and draw Lines Parallel with the Base Lines of the Hip, then take the Distance from the Plan of the Hip to the Side of the Plan Δ , as $1, 2, 3, 4, 5, 6, 7, 8, 9, 10$ and put them on the Hips, as $1, 2, 3, 4, 5, 6, 7, 8, 9, 10$, which gives the true Backing in any Case required. Note when the parts are set on at Bottom and Top of the Hip the Mould may be shifted and mark'd which shows the Wood to come off.

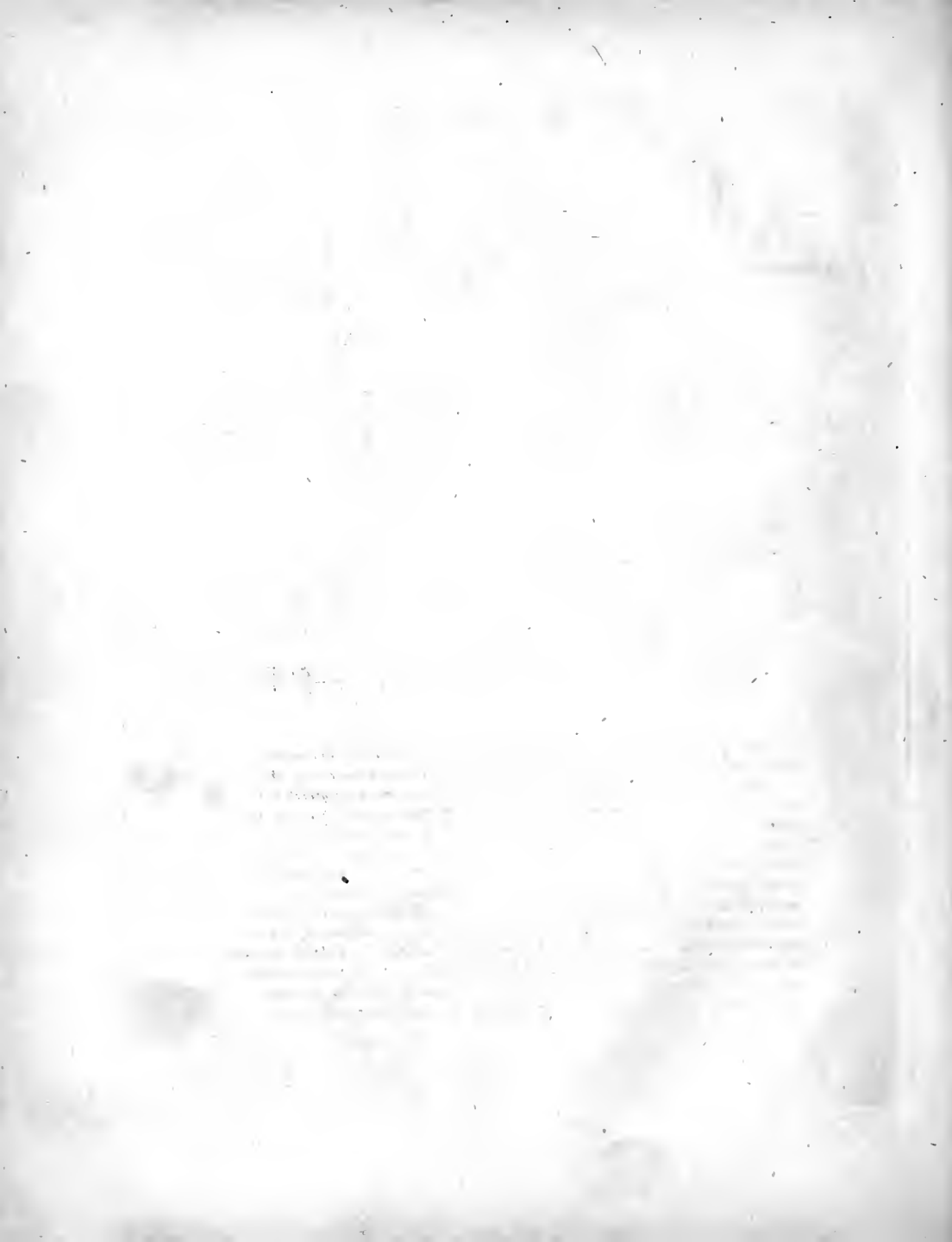

THE HISTORY OF THE

REIGN OF KING CHARLES THE FIRST

BY JOHN BURNET, BISHOP OF SALISBURY

IN TWO VOLUMES

LONDON, Printed by J. Sturges, at the Black-Swan in St. Dunstons Church-yard, in the Year 1724.

THE SECOND VOLUME

CONTAINING THE HISTORY OF THE

REIGN OF KING CHARLES THE FIRST

FROM THE DEPARTURE OF KING CHARLES THE FIRST

FROM ENGLAND, TO HIS RETURN

TO ENGLAND, IN THE YEAR 1645.

To face P L A T E IX.

Trusses for the Domes of Churches, &c.

A. Is a Truss for a Dome, with a Lanthorn or Cupola at the Top, to give Light. B. the Plan; the Kirb or Plate to be in two Thicknesses, which is likewise best for the Ribs, and for the Kirb on which the Cupola stands. The Curve of the Dome A. is a Semi-circle, or will serve for a Semi-ellipsis. The Moulds *f* and *c* in the Plan B. cut the Sweep of the Purlines; and the Moulds *b a* and *c d* are for the Top and Bottom of the Purlines. C. is a Cone or Lanthorn to light a Stair-Cafe, &c. the horizontal Bars must be squared in the same Manner as the Purlines in A. The Mould for cutting or squaring the Purlines, is like the bottom Mould *f* in B. so that if the Purlines be cut to the Thickness required as in the Section A, and also to the Mould *f*, then *a* is the Mould for the Bottom and *b* for the Top, as appears by the Lines let fall to the Plan B from the Purlines *g* and *h*; then C in the Plan is the Top and *d* the bottom Mould. *l* is the sweep Mould for the Top of the Purline *h*. By this Rule the Purlines may be squared, which completes the Work. If the Plan B, the Ribs and Purlines are in Size and Number, as the Cone C, it will do for a Lanthorn or Light to a Stair-Cafe, &c. the Manner of squaring the Ribs and Cross Bars is the same as the Dome.

Trusses for the Domes of Churches &c.

Plate IX.

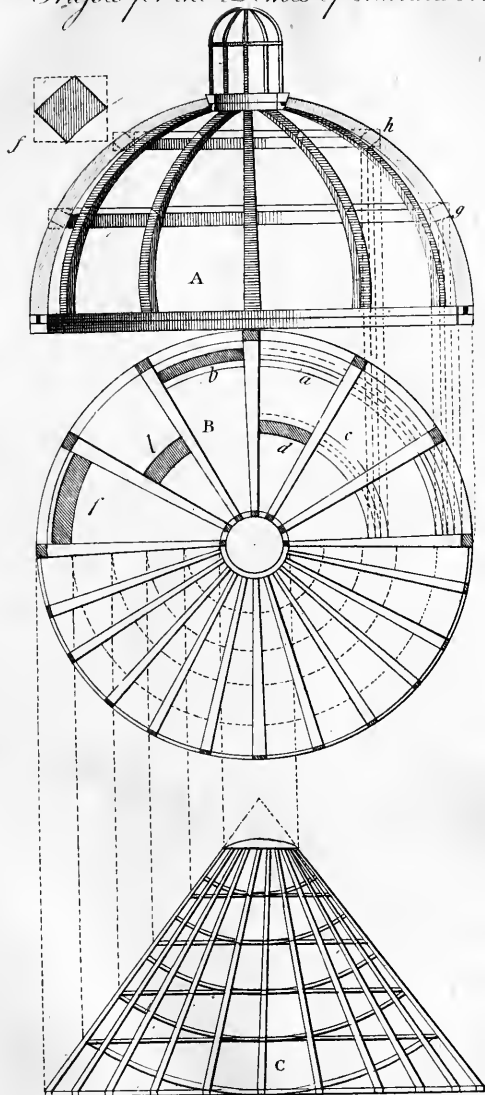

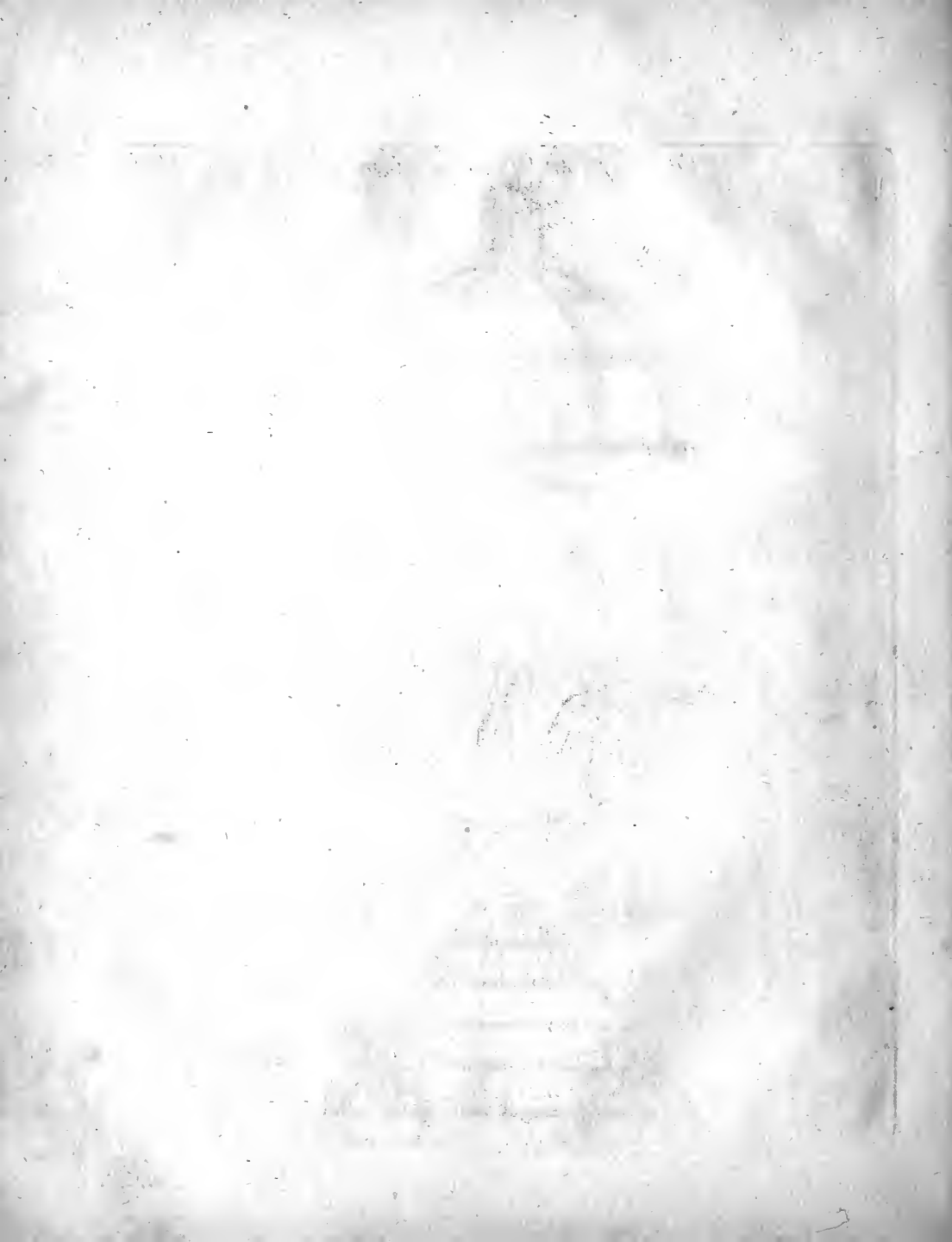

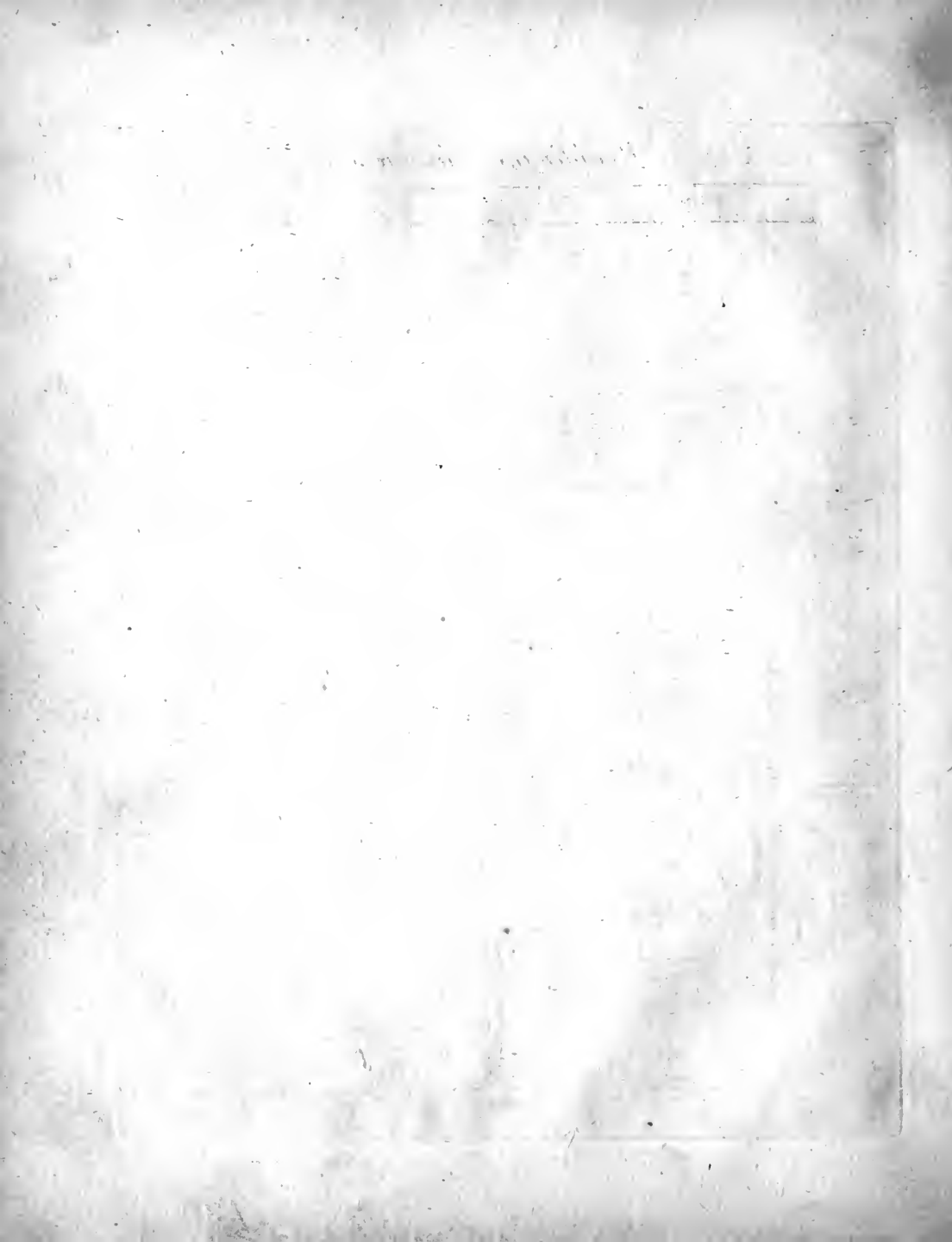

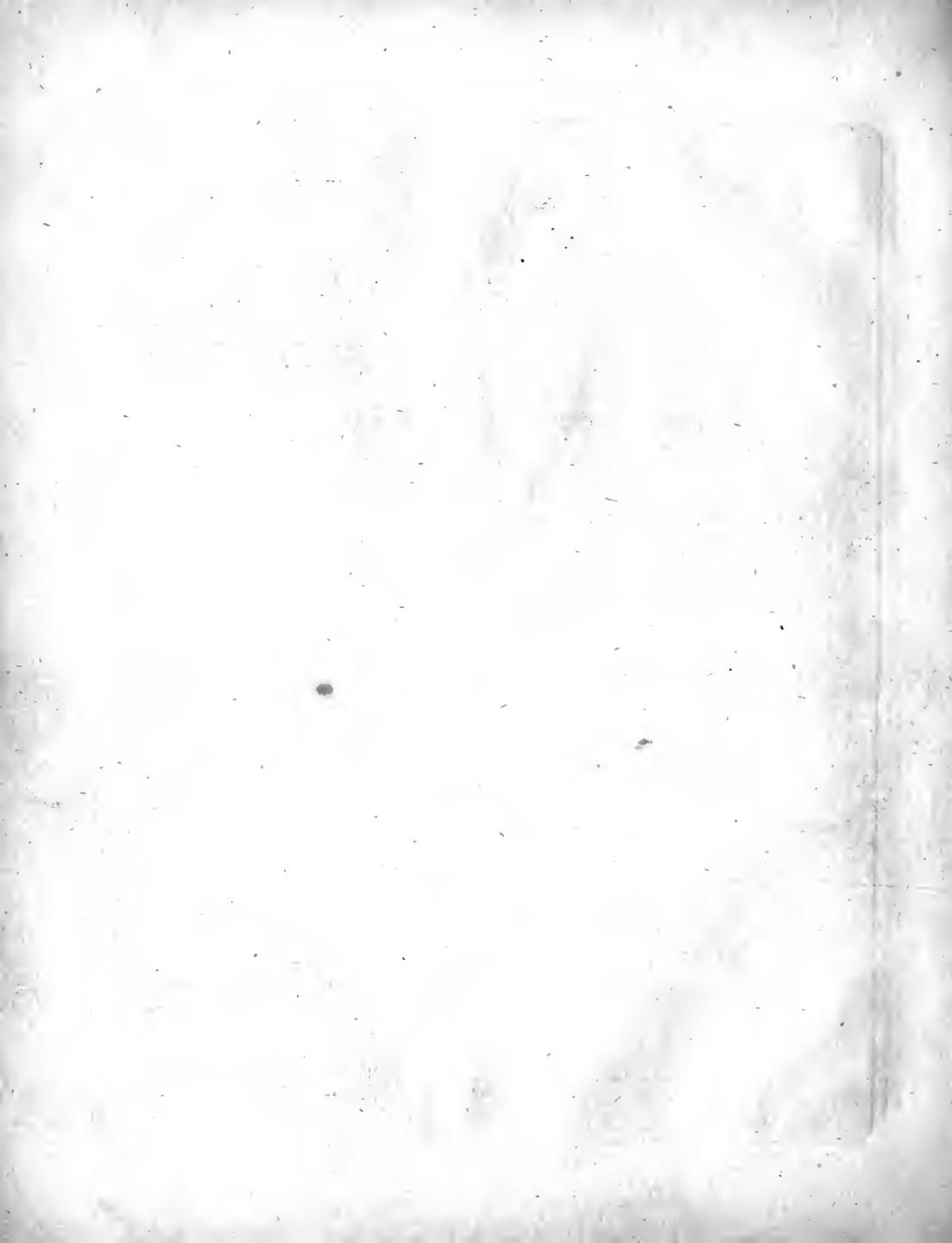

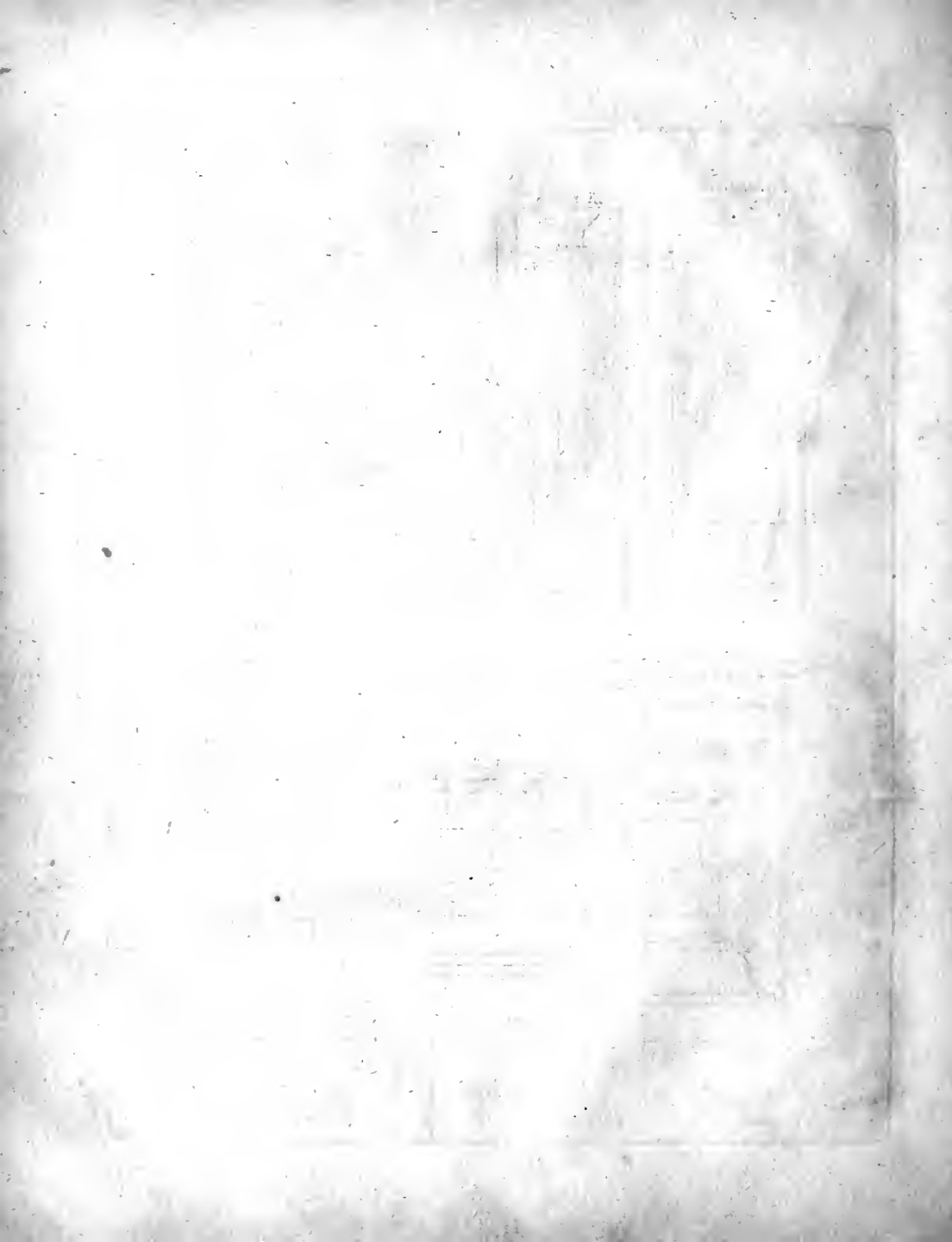

Frontispiece in the Tuscan Order.

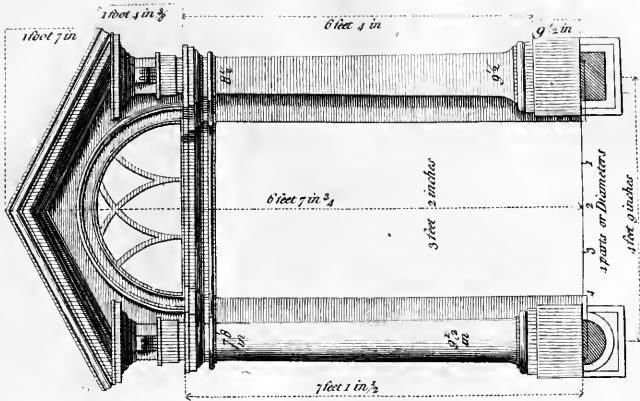

Divide the Door into 12 parts one is the Diameter of the Pilaster

A Scale of one Module.

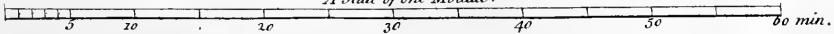

Divide the given Module into 12 parts and one of those parts into 3 gives the Minutes.

The Tuscan Entablature.

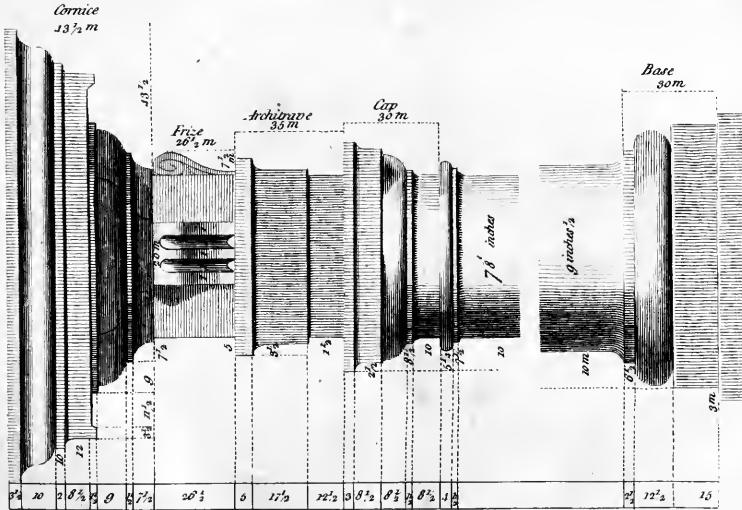

12	20	2	8 1/2	3	9	6	7 1/2	20 1/2	3	17 1/2	12 1/2	3	8 1/2	3	8 1/2	12	20	12 1/2	15
----	----	---	-------	---	---	---	-------	--------	---	--------	--------	---	-------	---	-------	----	----	--------	----

82



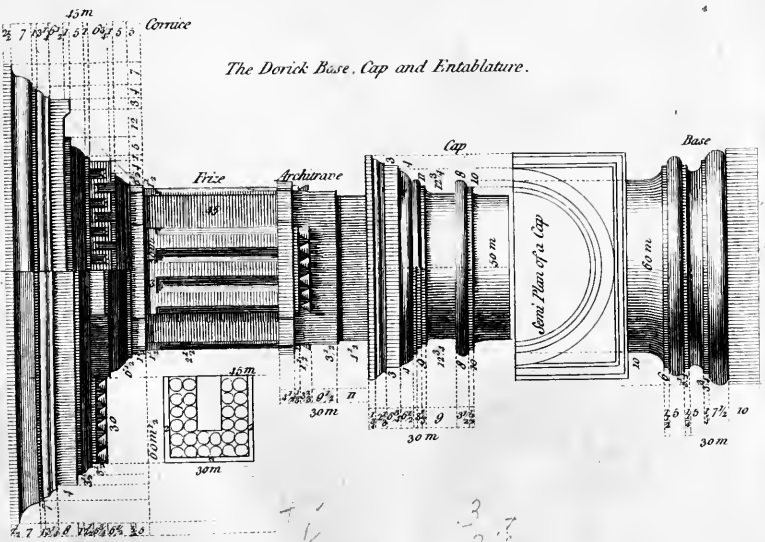
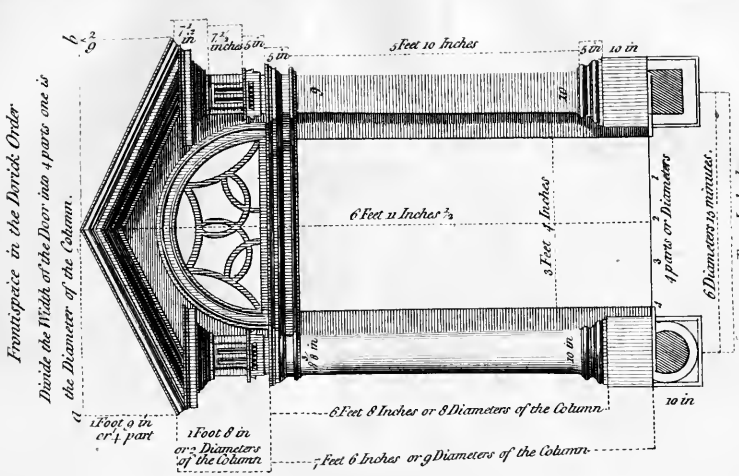

10-4

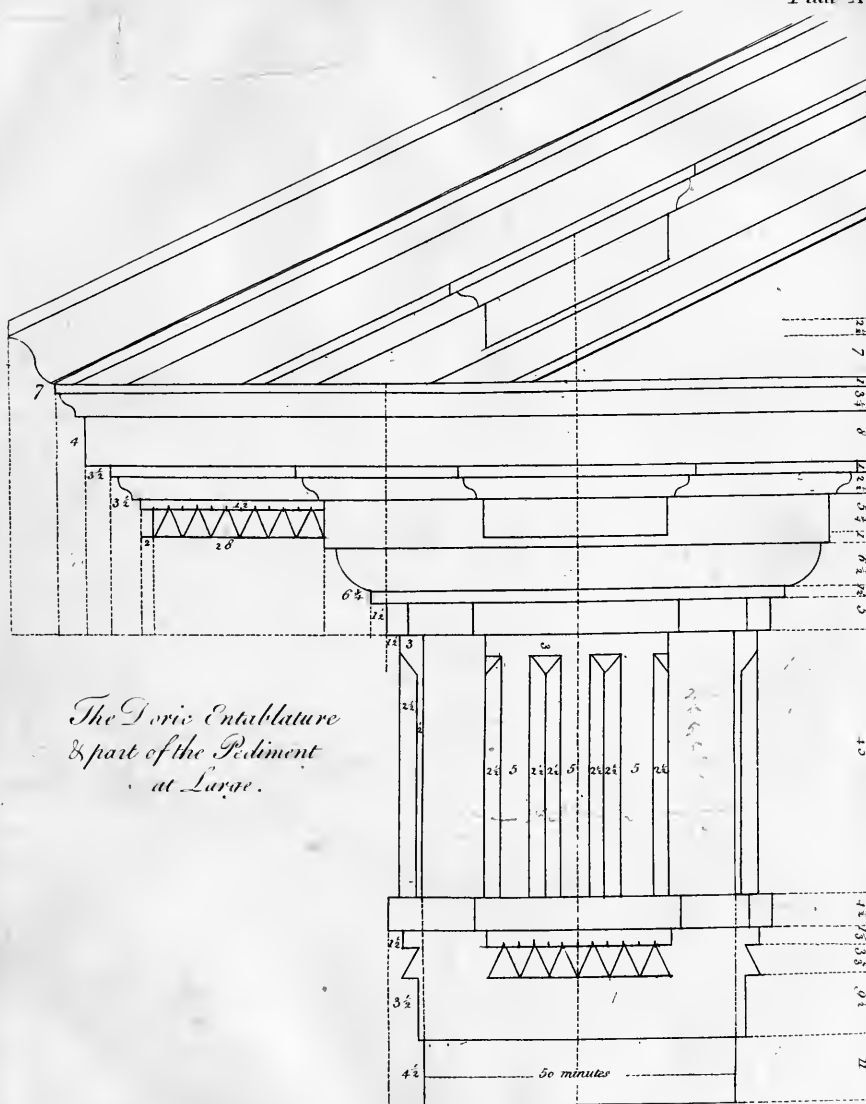

*The Doric Entablature
& part of the Pediment
at Large.*

50 minutes



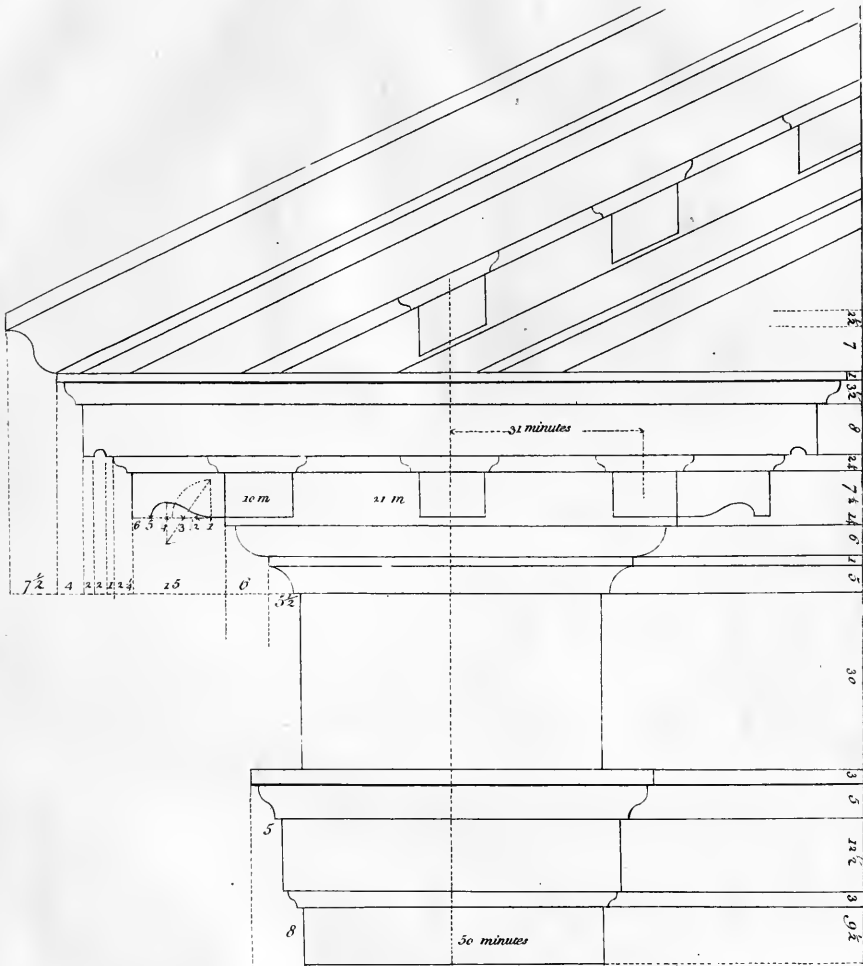

The Ionic Entablature with part of the Pediment at Large.

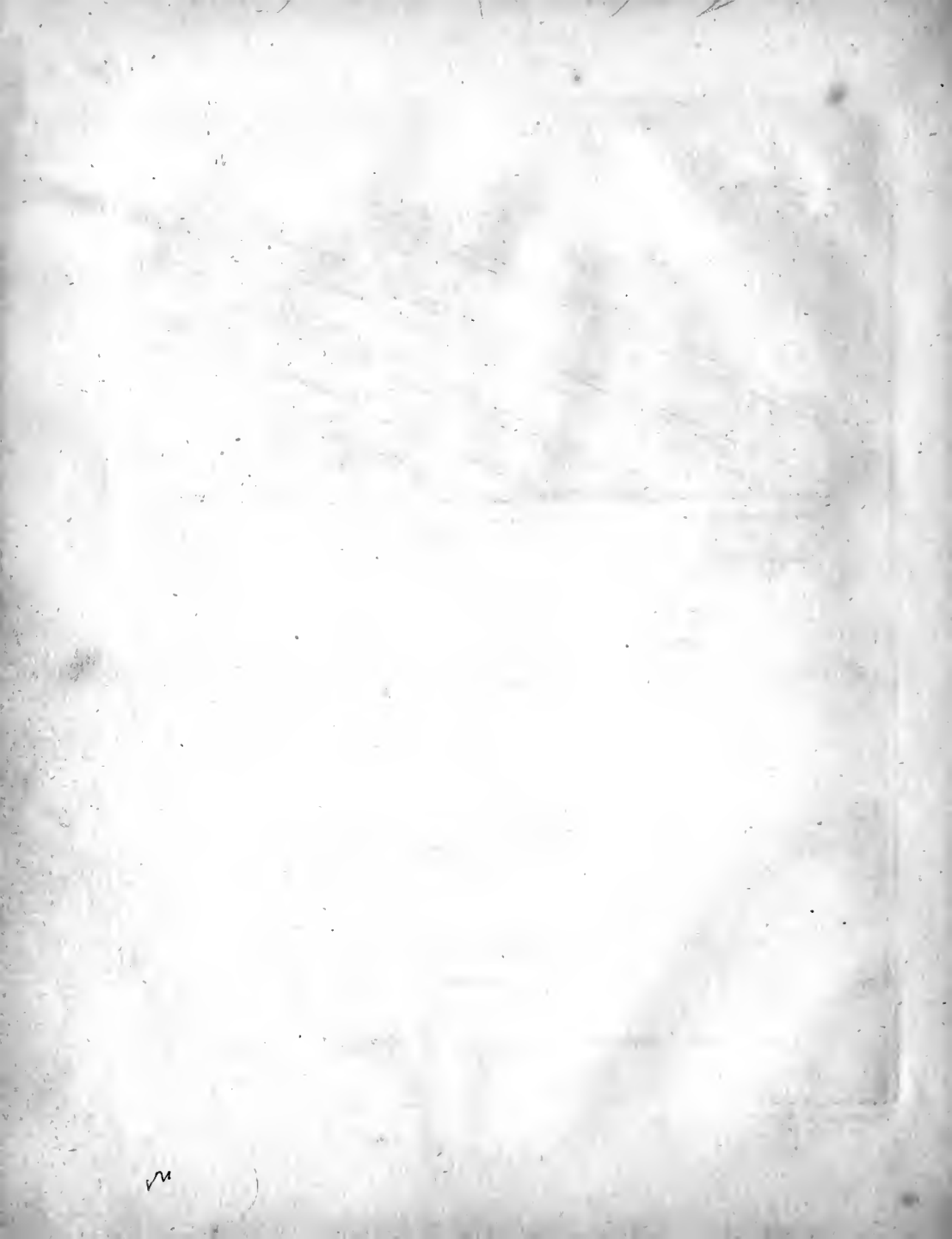

A Modern Ionic Capital, with Leaf as

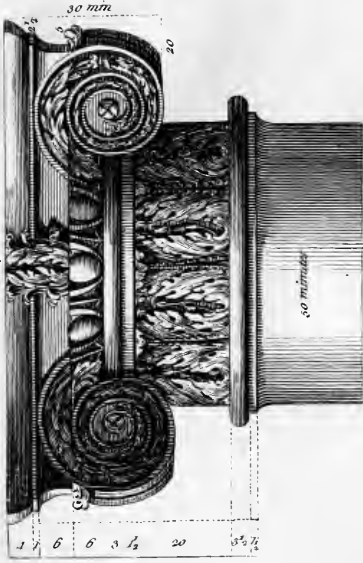

A Composed Cap for a Column.

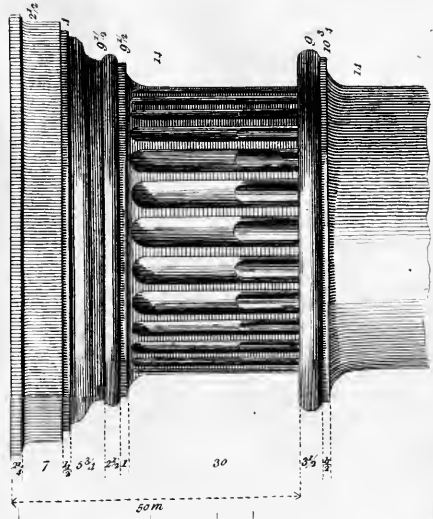

The Eye of the Volute of Capital.

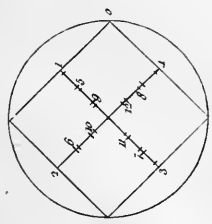

The Ionic Volute.

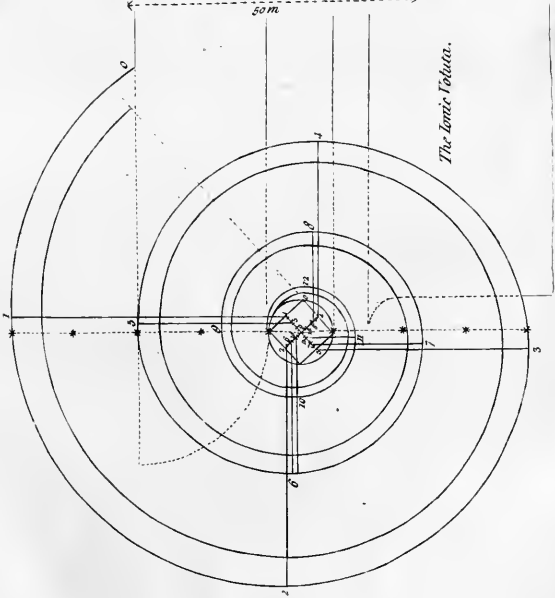



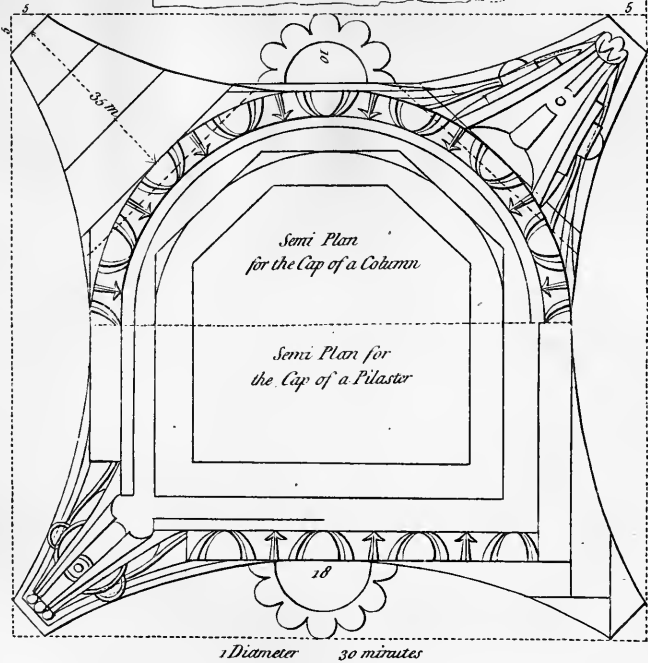
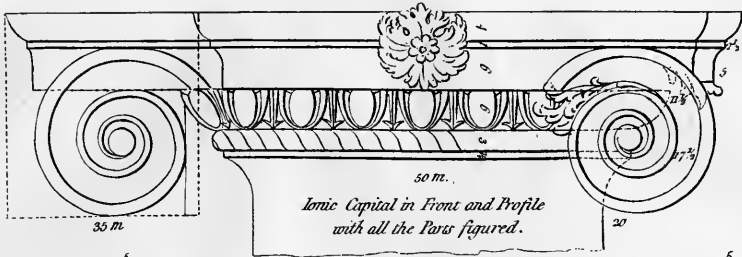

*The Body of the Cap with
the Mouldings worked
before the Horns are
Glued on.*

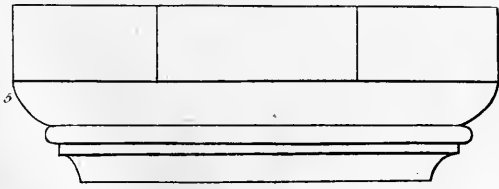

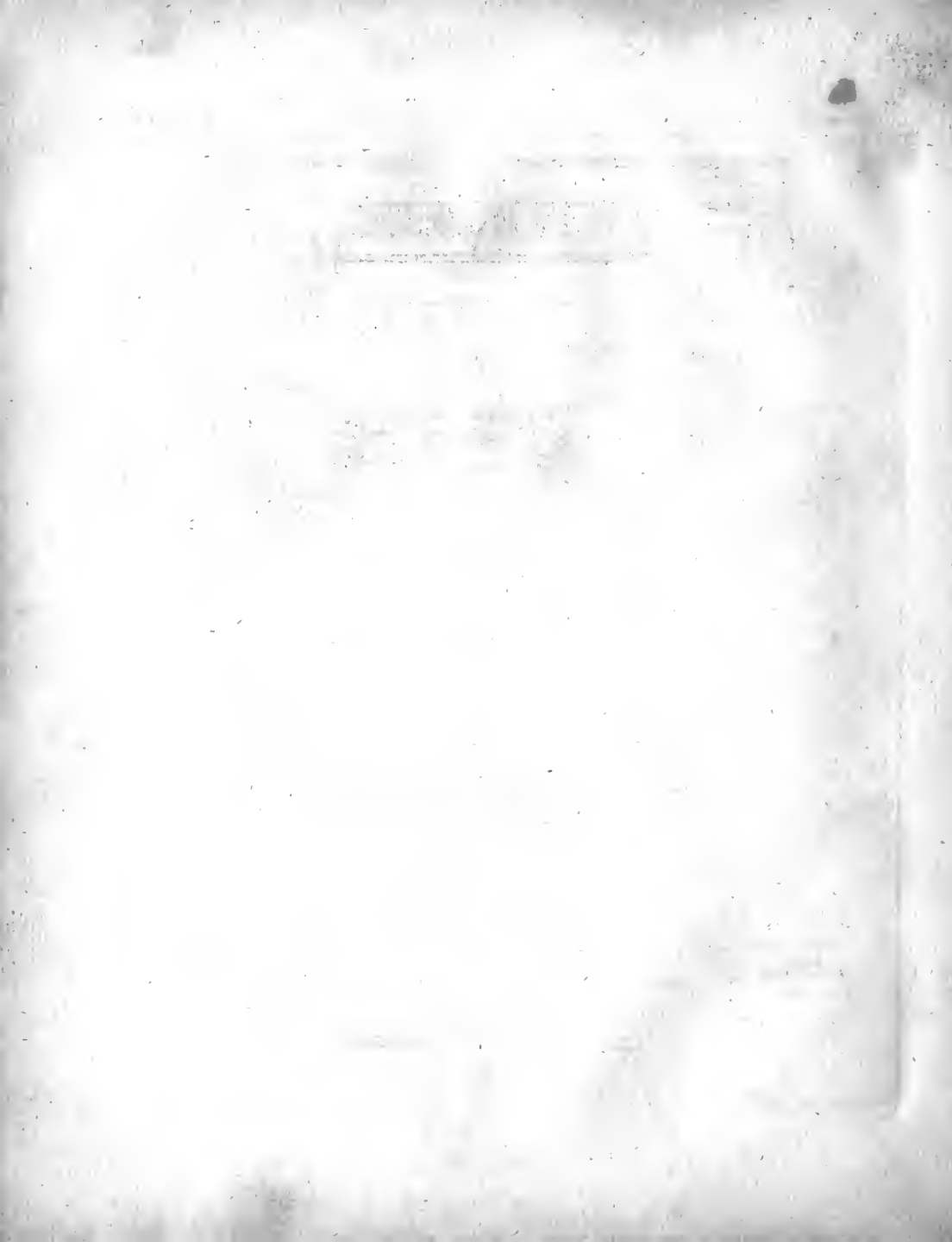

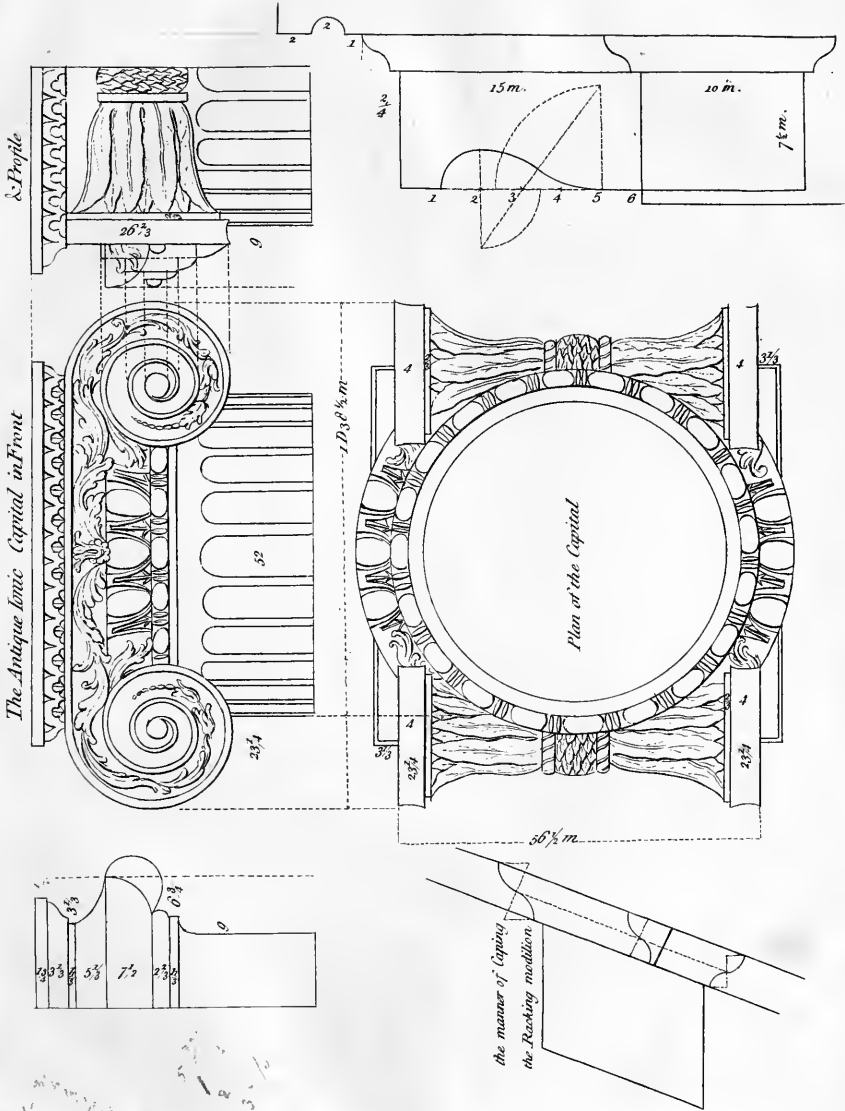

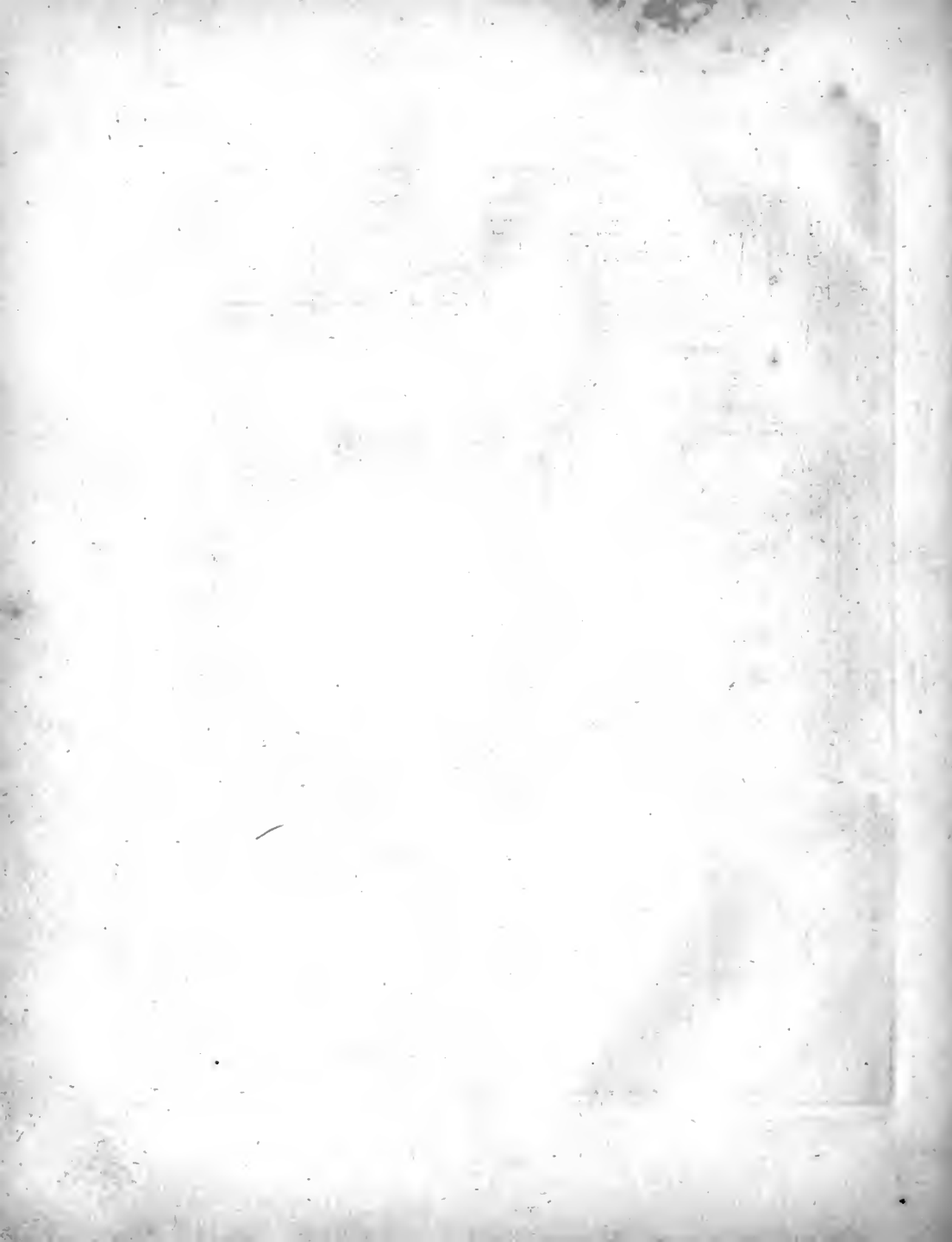

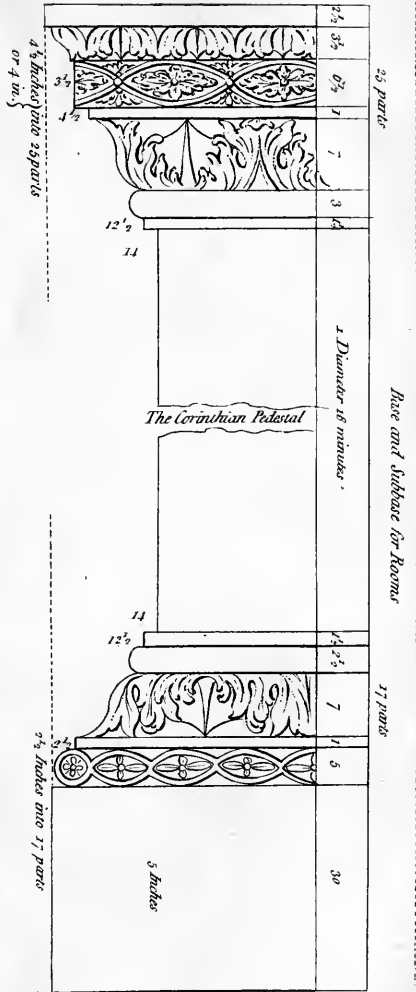
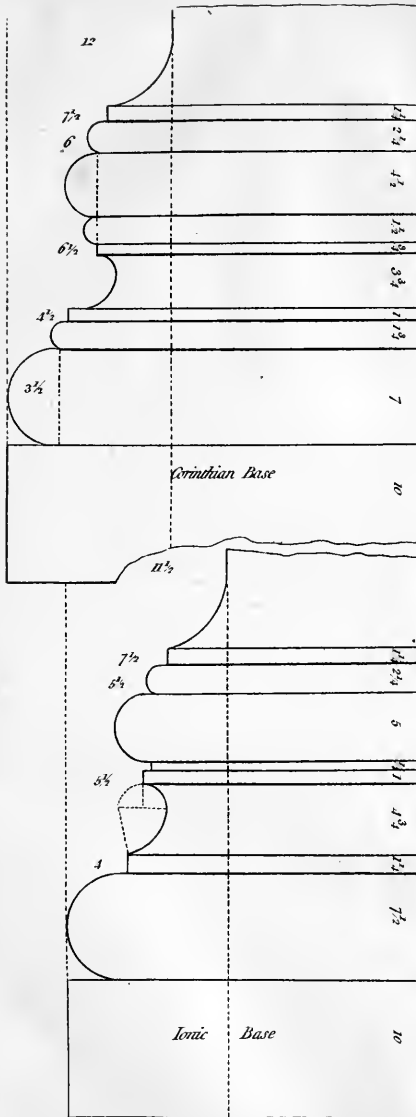

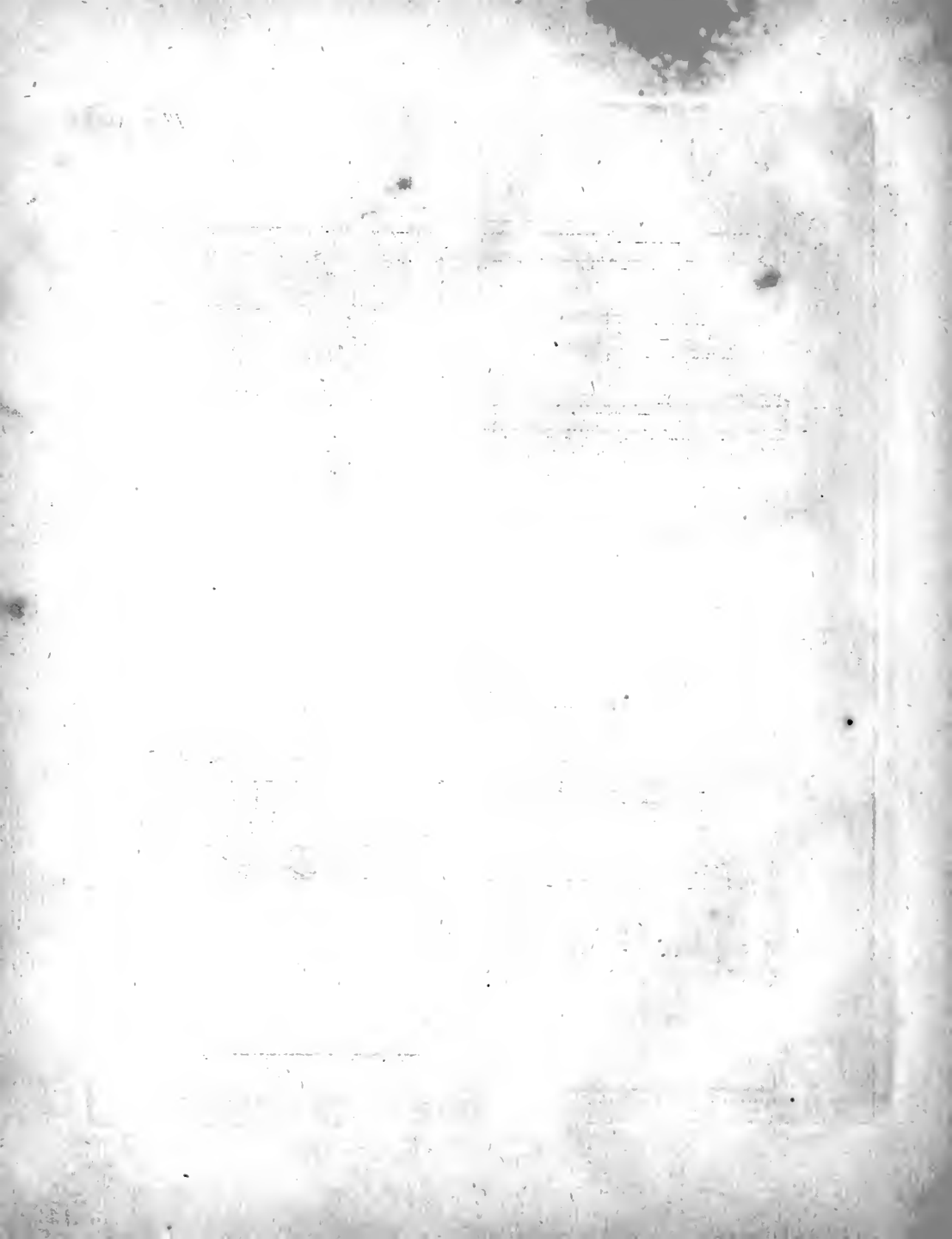

Corinthian Capital for a Column.

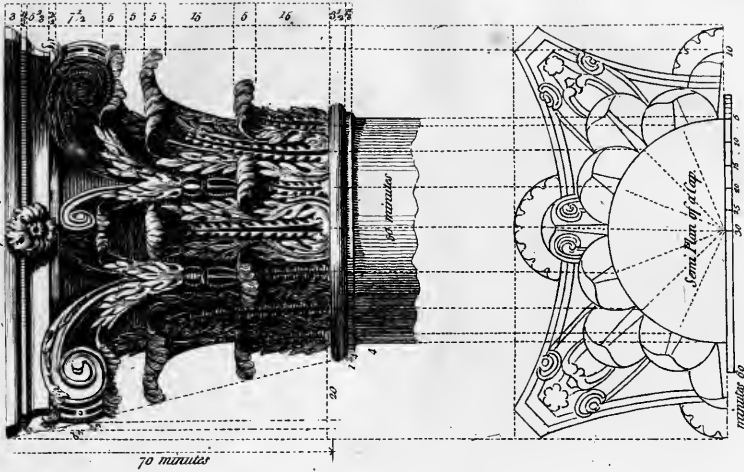

*A Modern
Composed Capital for a Column.*

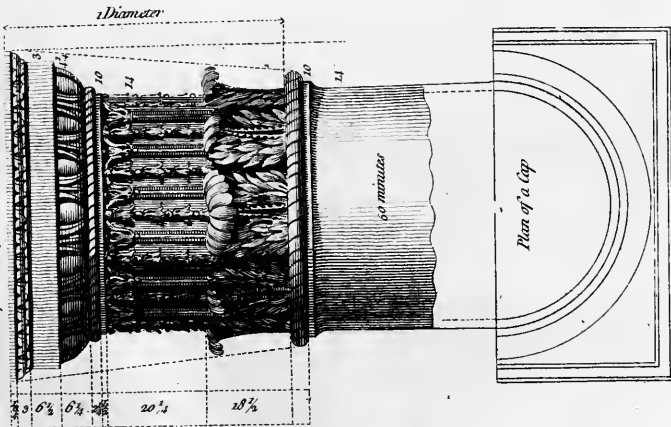

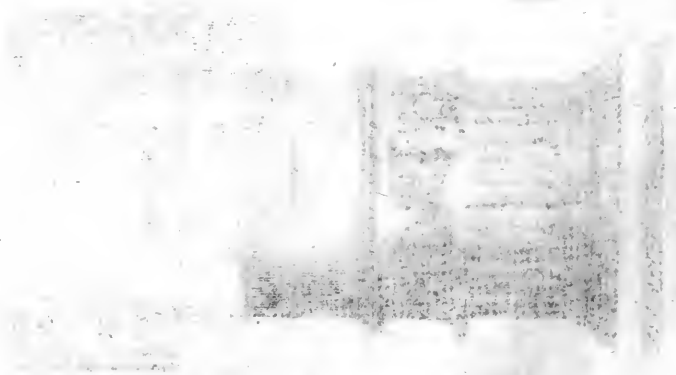
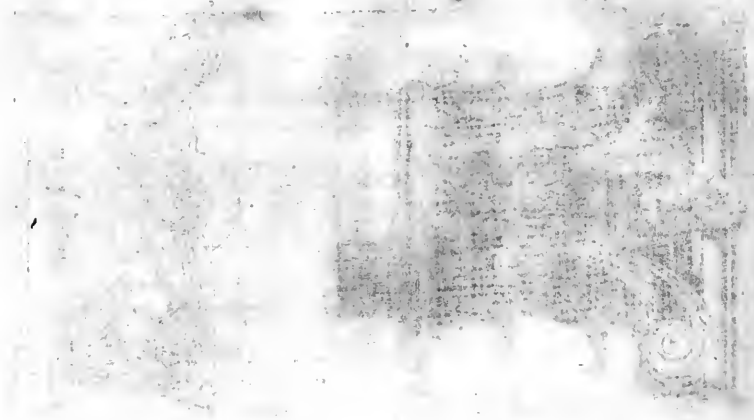

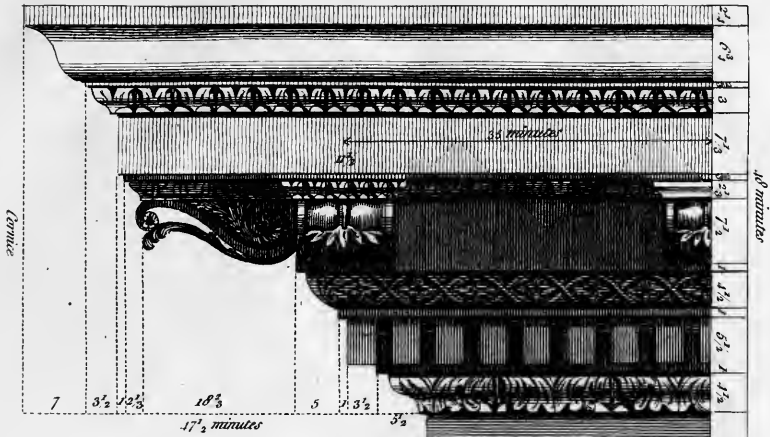

The Corinthian Entablature.

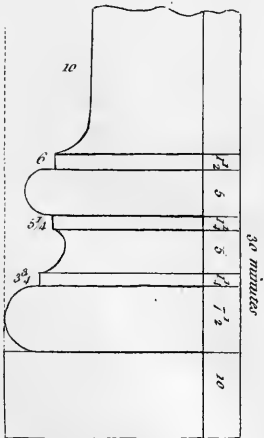

Attic Base to Dileo.

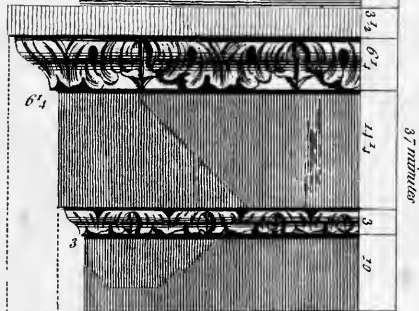

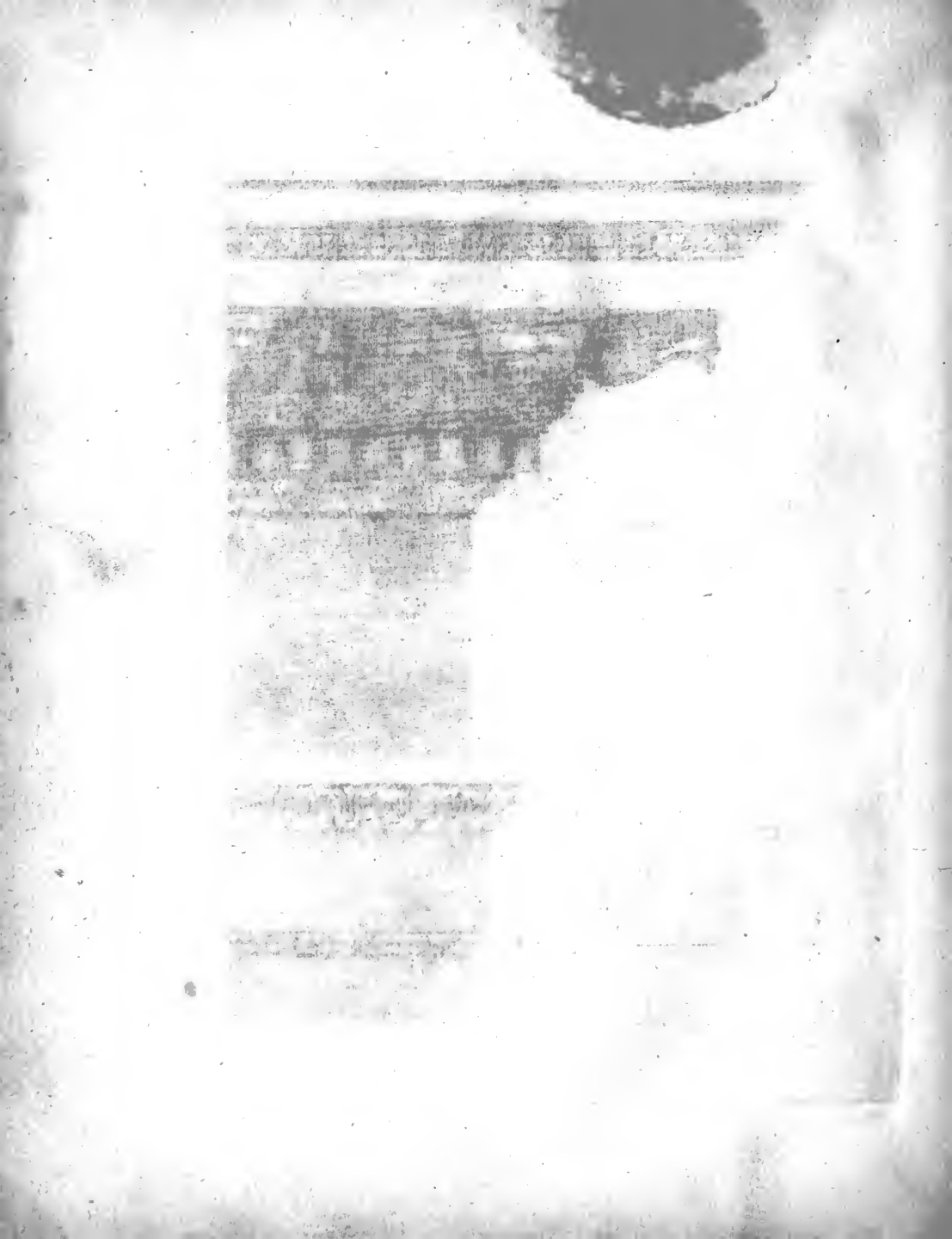

The Ancient Composite or Roman Capital

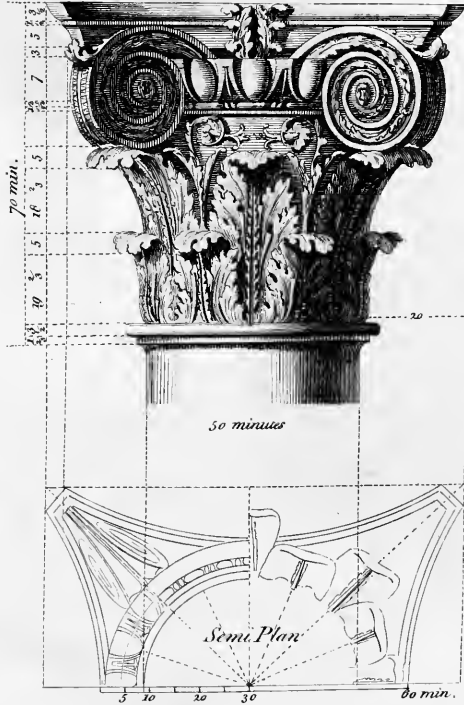

The Proportions of Composite Entablature are the same as the Corinthian.

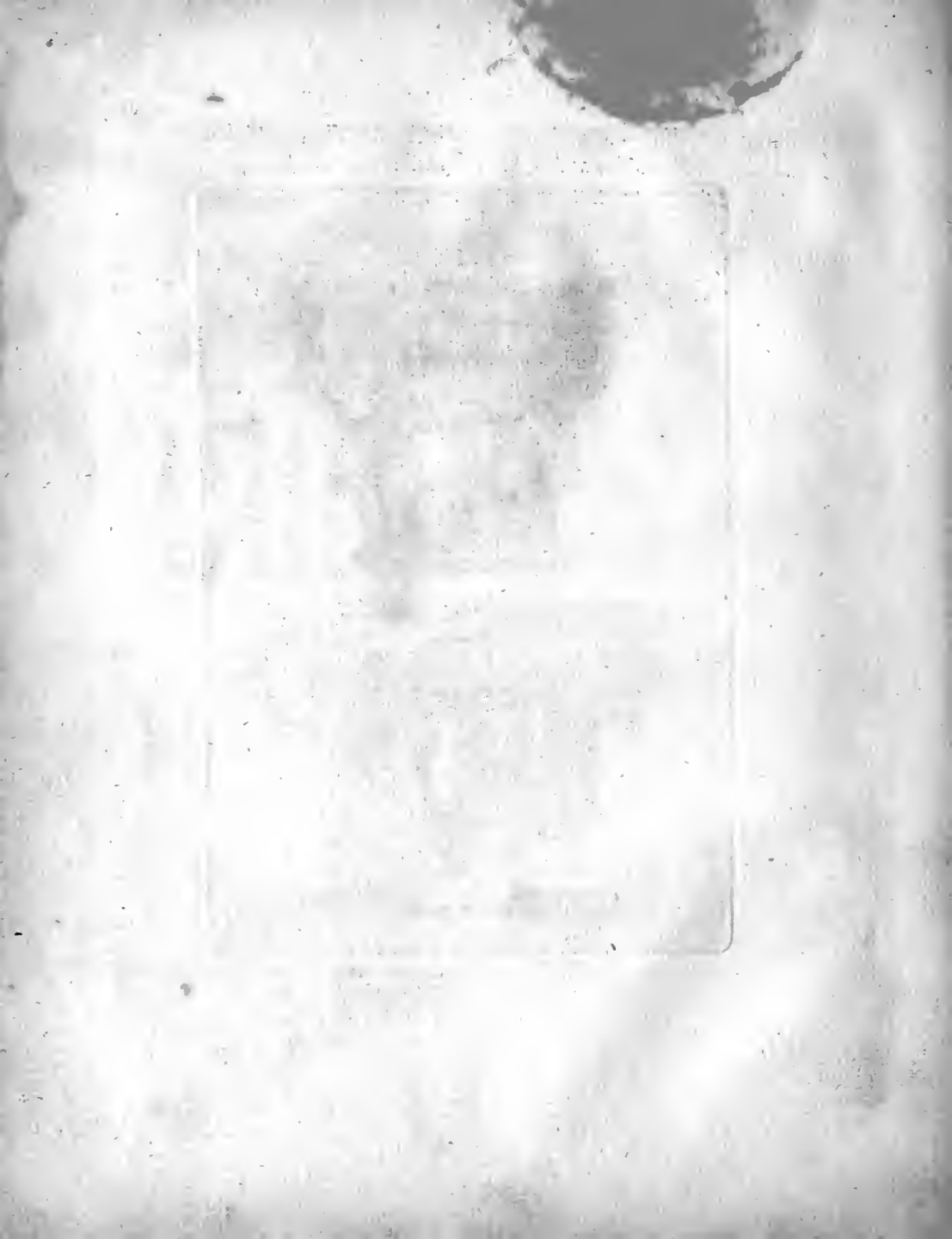



may be used with the Attic Base.

THE UNIVERSITY OF CHICAGO

PHYSICS DEPARTMENT

PHYSICS 311

LECTURE 1

Planceer of the Corinthian Cornice at an External Angle.

Planceer of the Ionic Cornice at an External Angle.

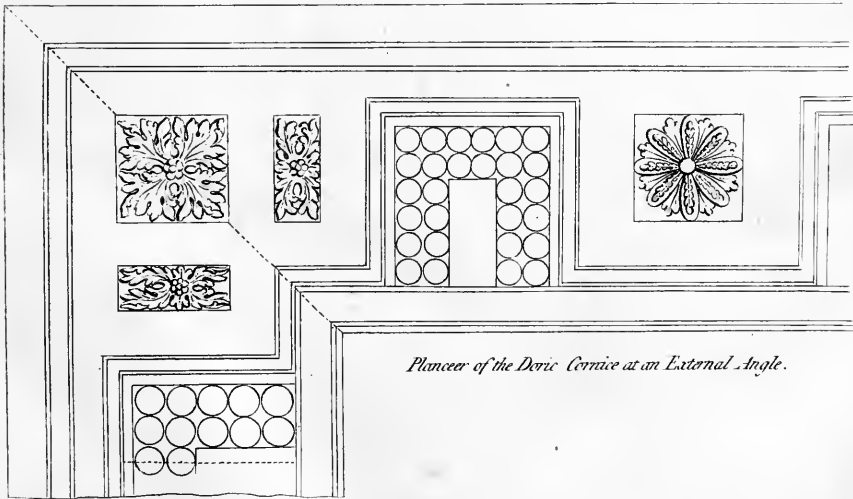
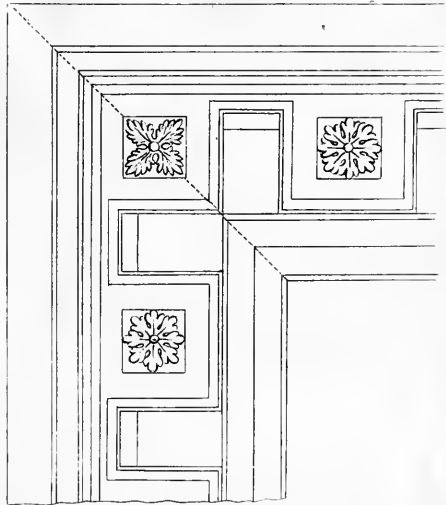
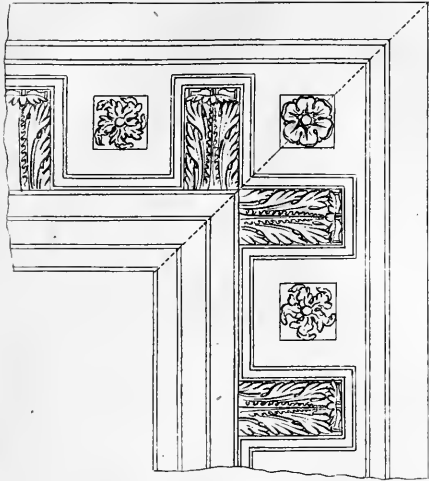

Planceer of the Doric Cornice at an External Angle.

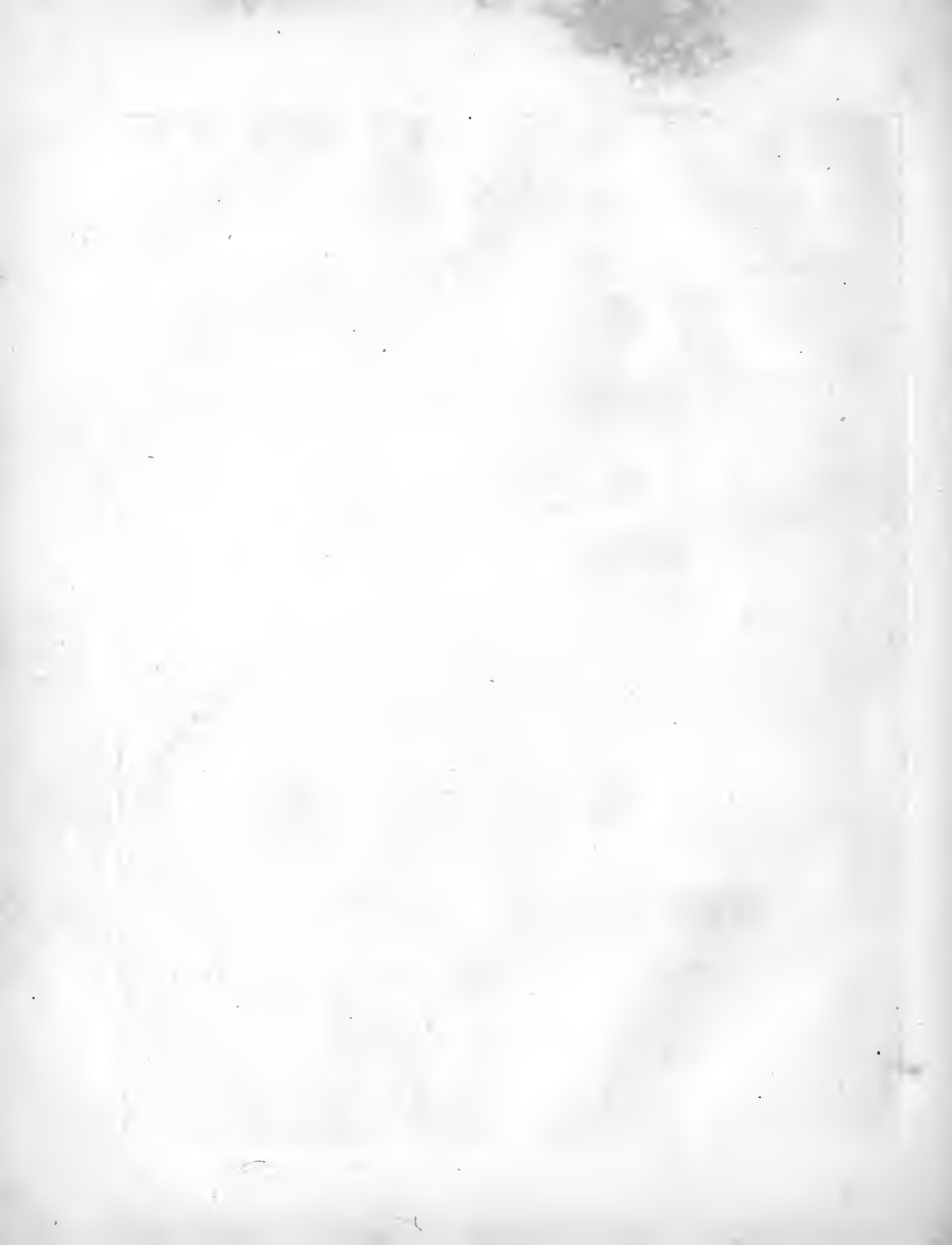

Gluing of Columns.

This Column Diminishes from one third of the Height.

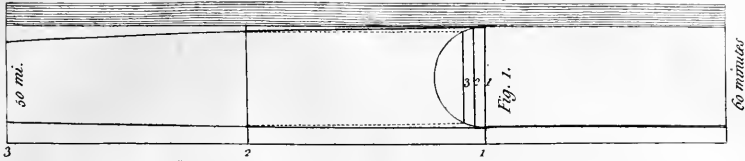

The manner of Gluing up Columns & Diminishing them

This Column Diminishes from the Bottom to the Top

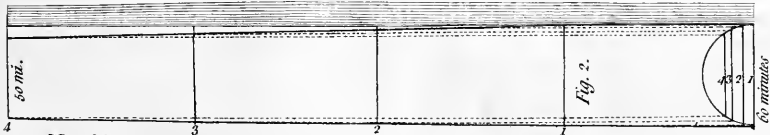

When Columns are fluted divide the Round or Circumference into 60 parts give three to a Flute and one to a Fillet.

Diminish the Staves of the Columns on the Faces before they are Glued together, this is a very safe and sure way for making the Column.

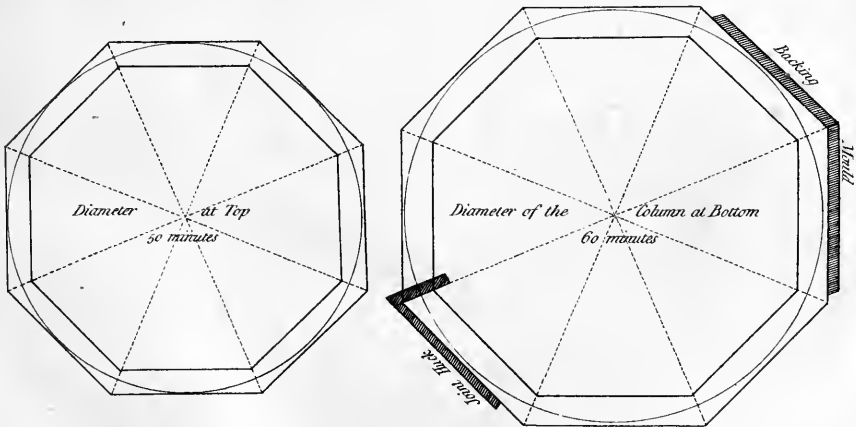

When Pillars are Fluted divide the Breadth or Diameter into 20 parts give one to a Fillet and three to a Flute.



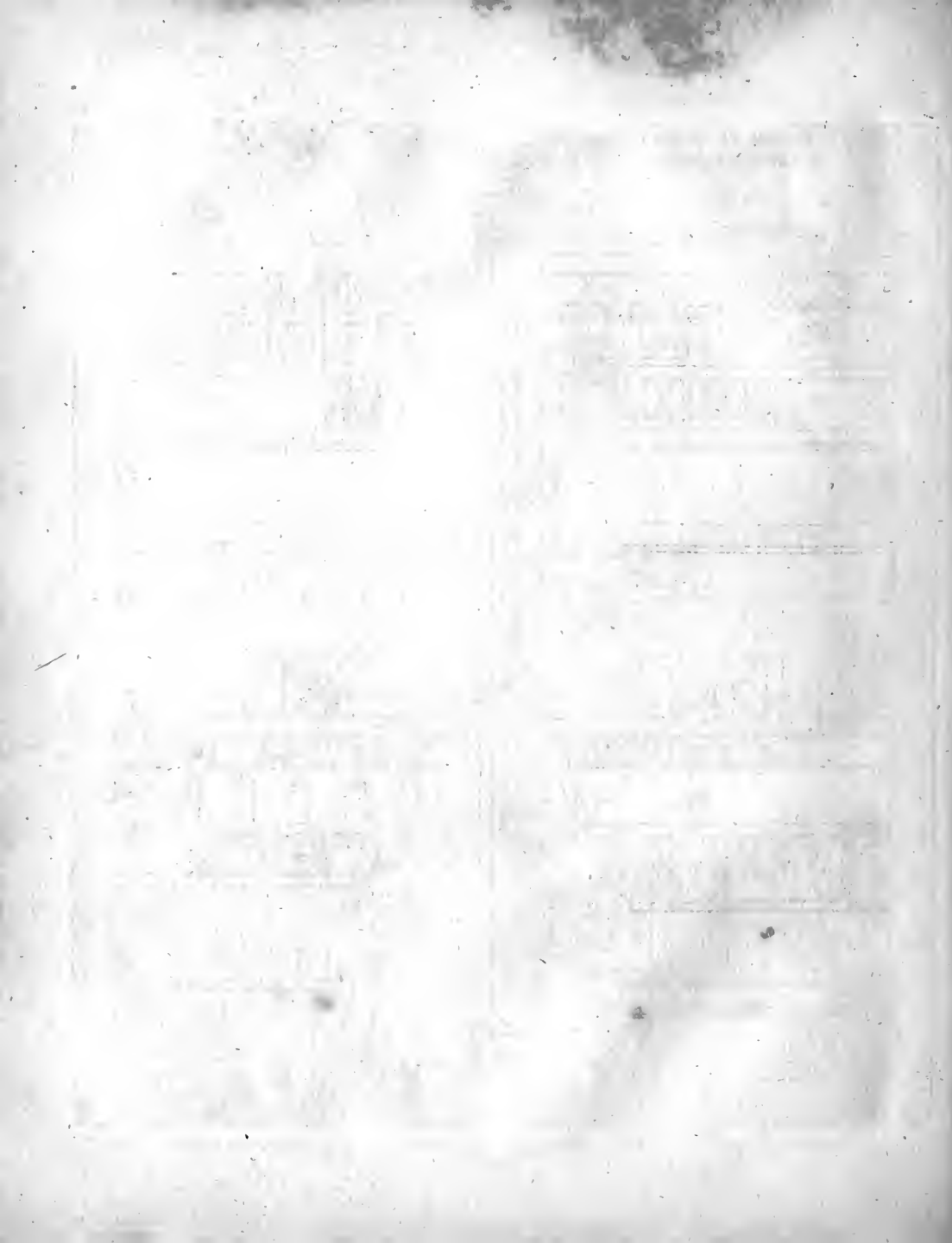

*Entablature for Doors Windows &c.
with all the Measures figured for Practice at large.*

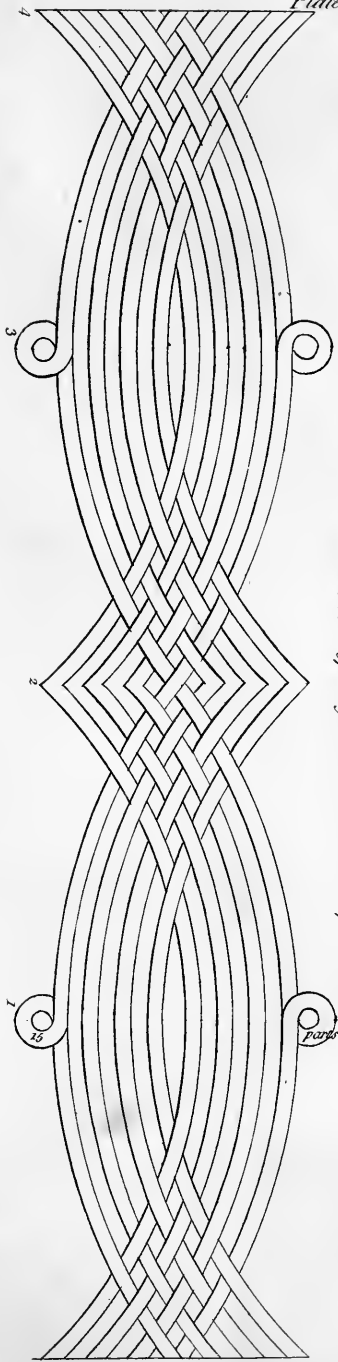
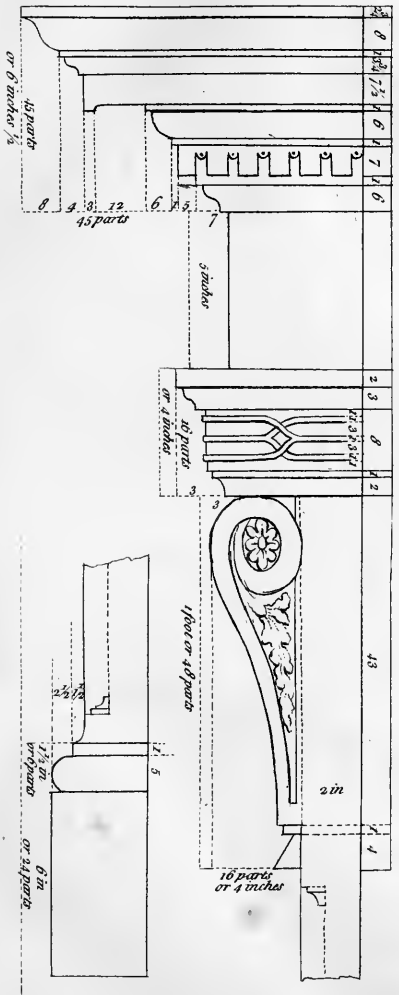

*I include for the Working Pattern of a Pediment &c.
Beside the Width two 12 parts, give one to a Rib & one to a Space.*

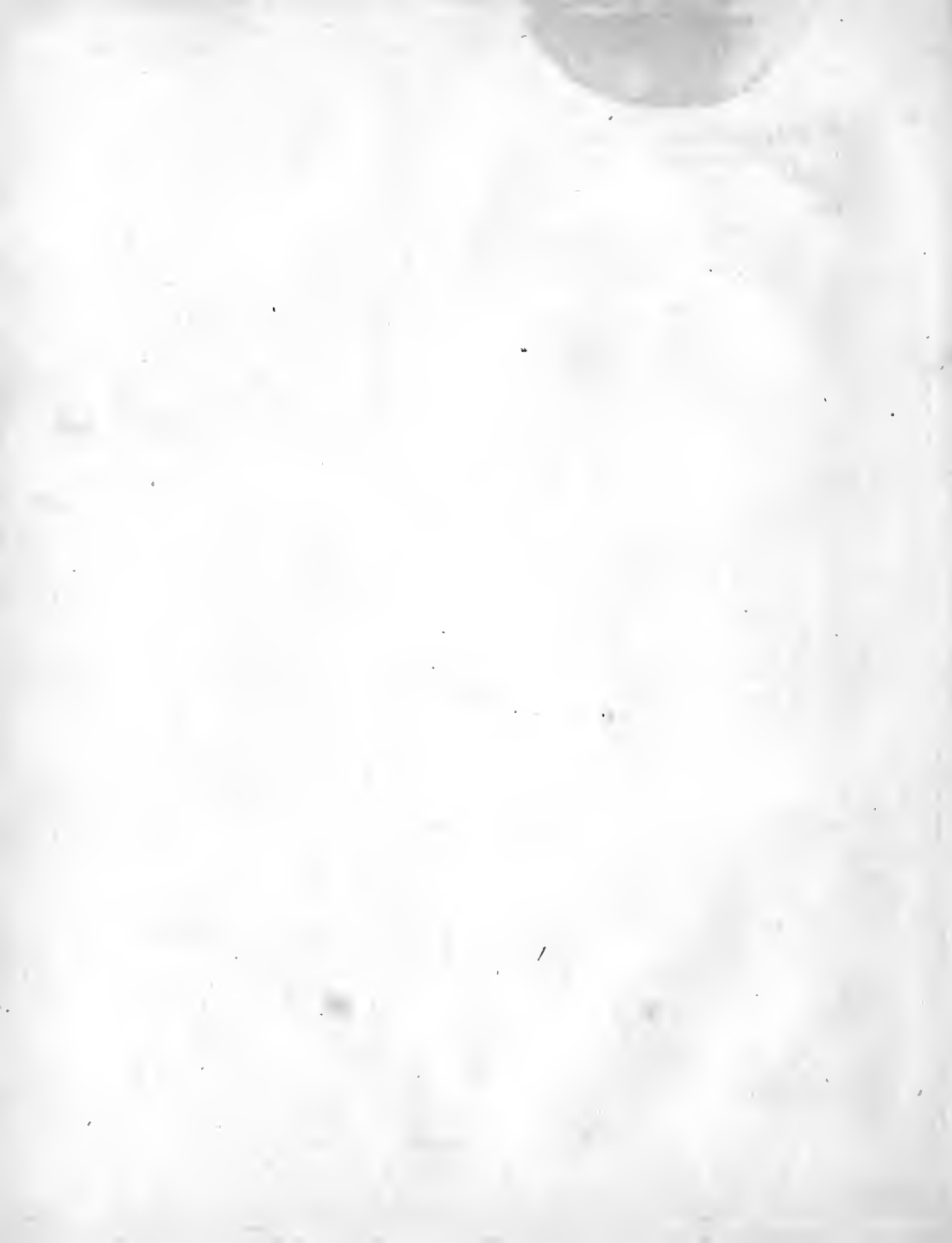

Two Entablatures for Doors,
the Measures figured.

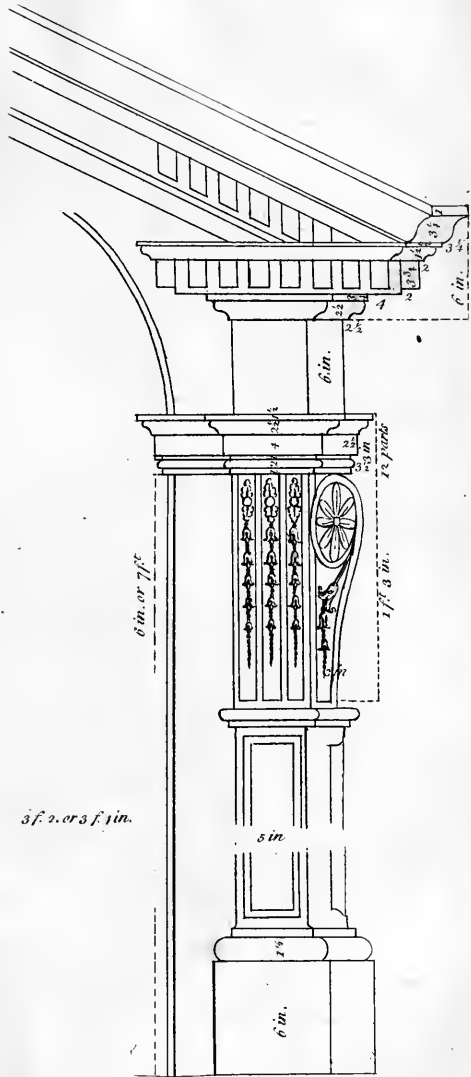
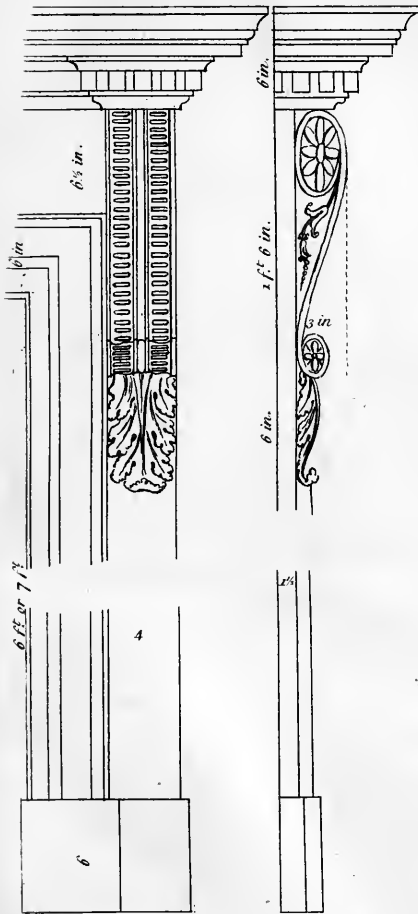

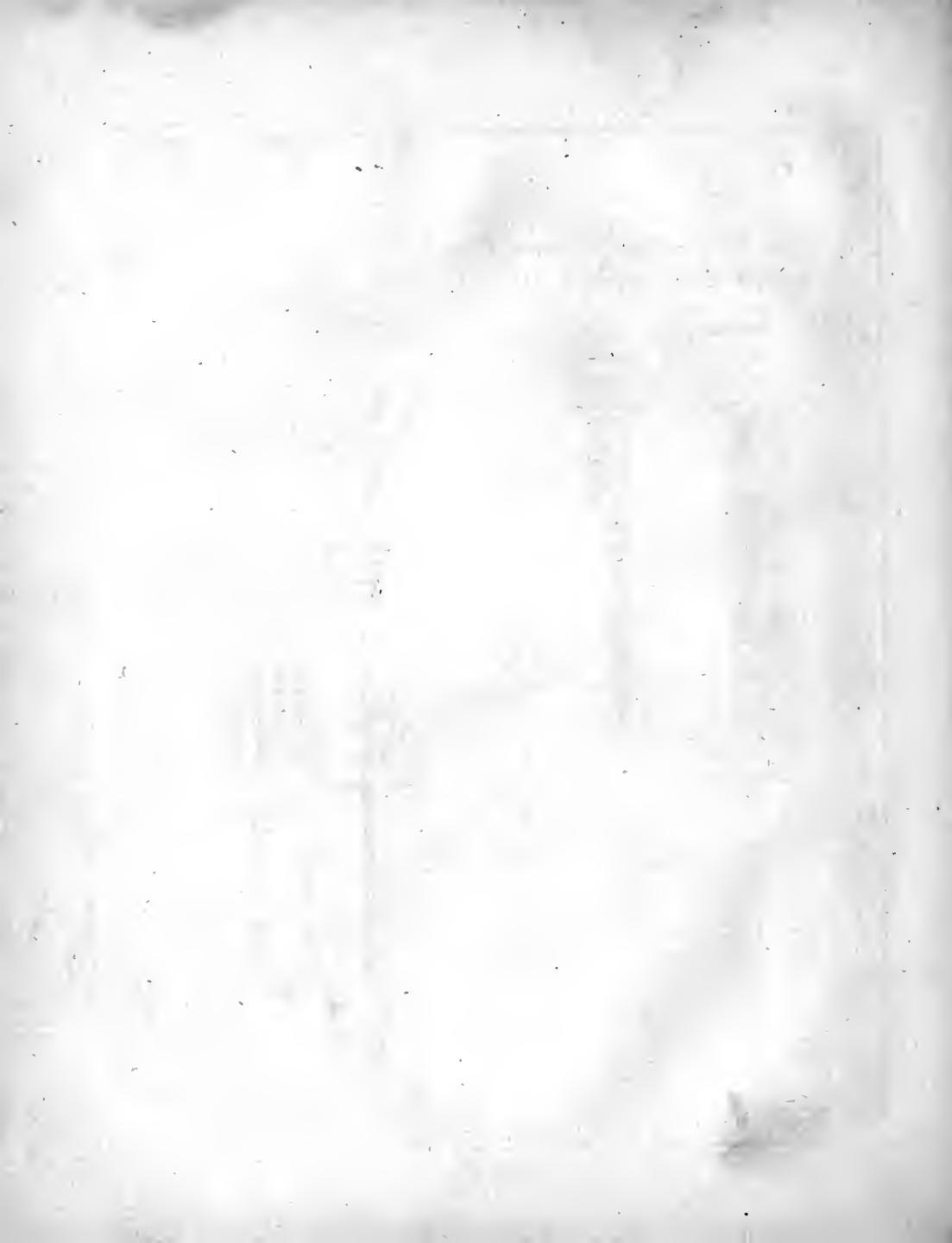

Frontispieces for Doors

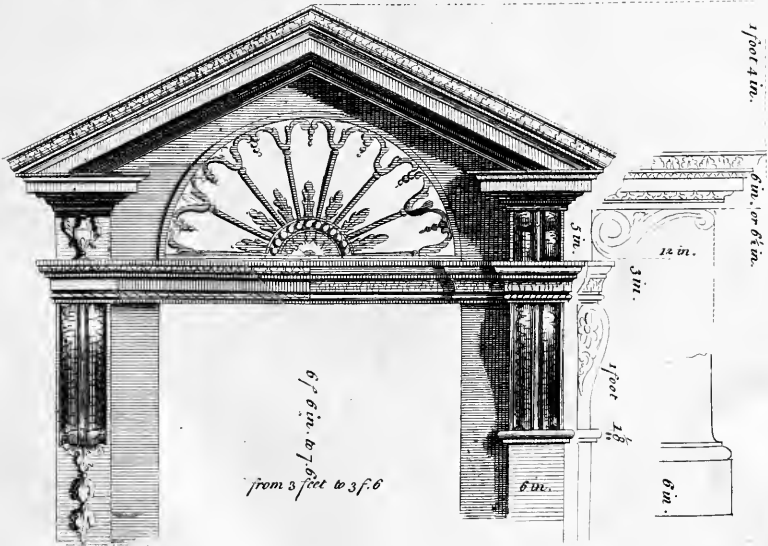
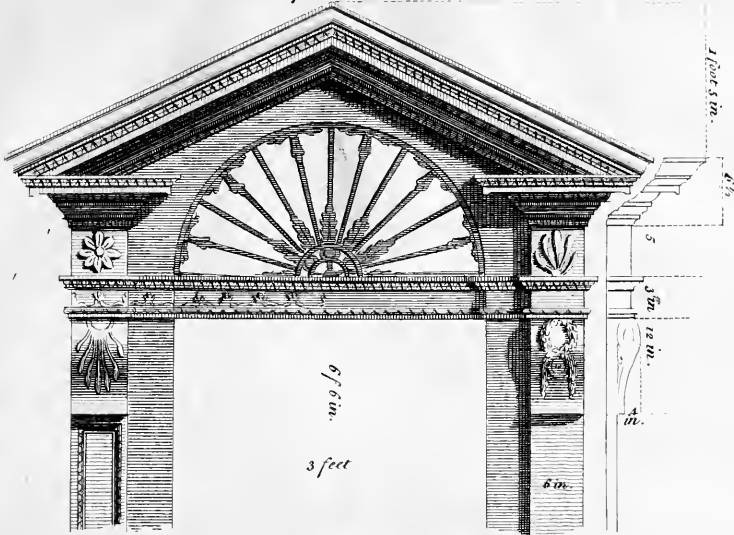

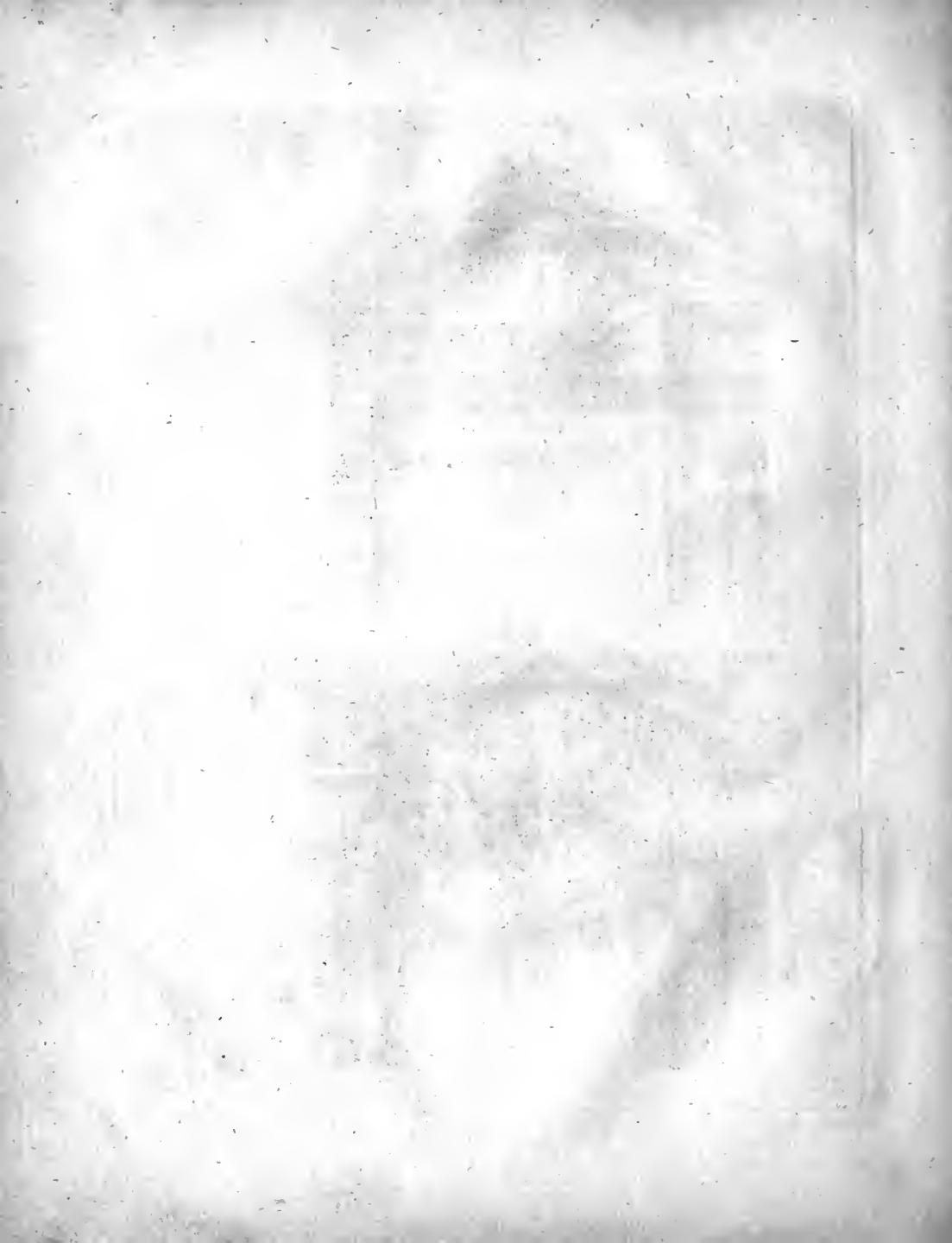

Designs for Door Cases.

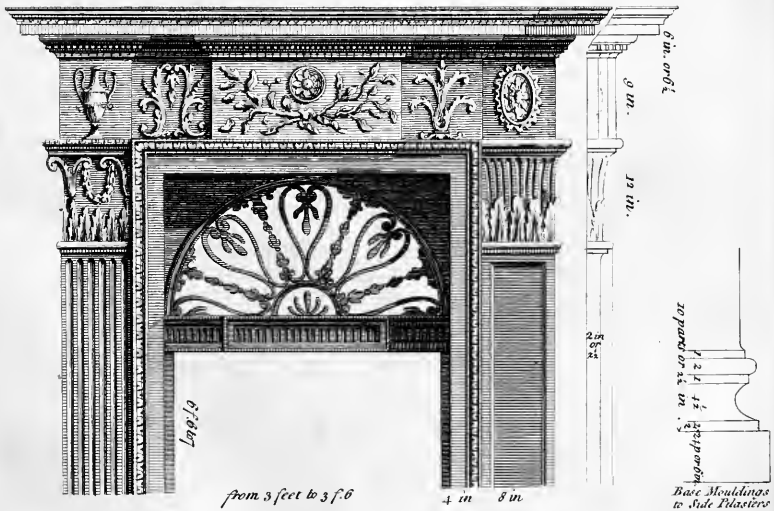
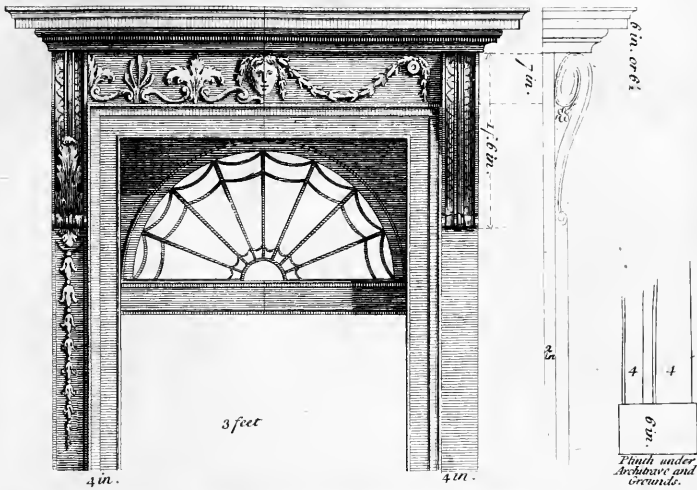

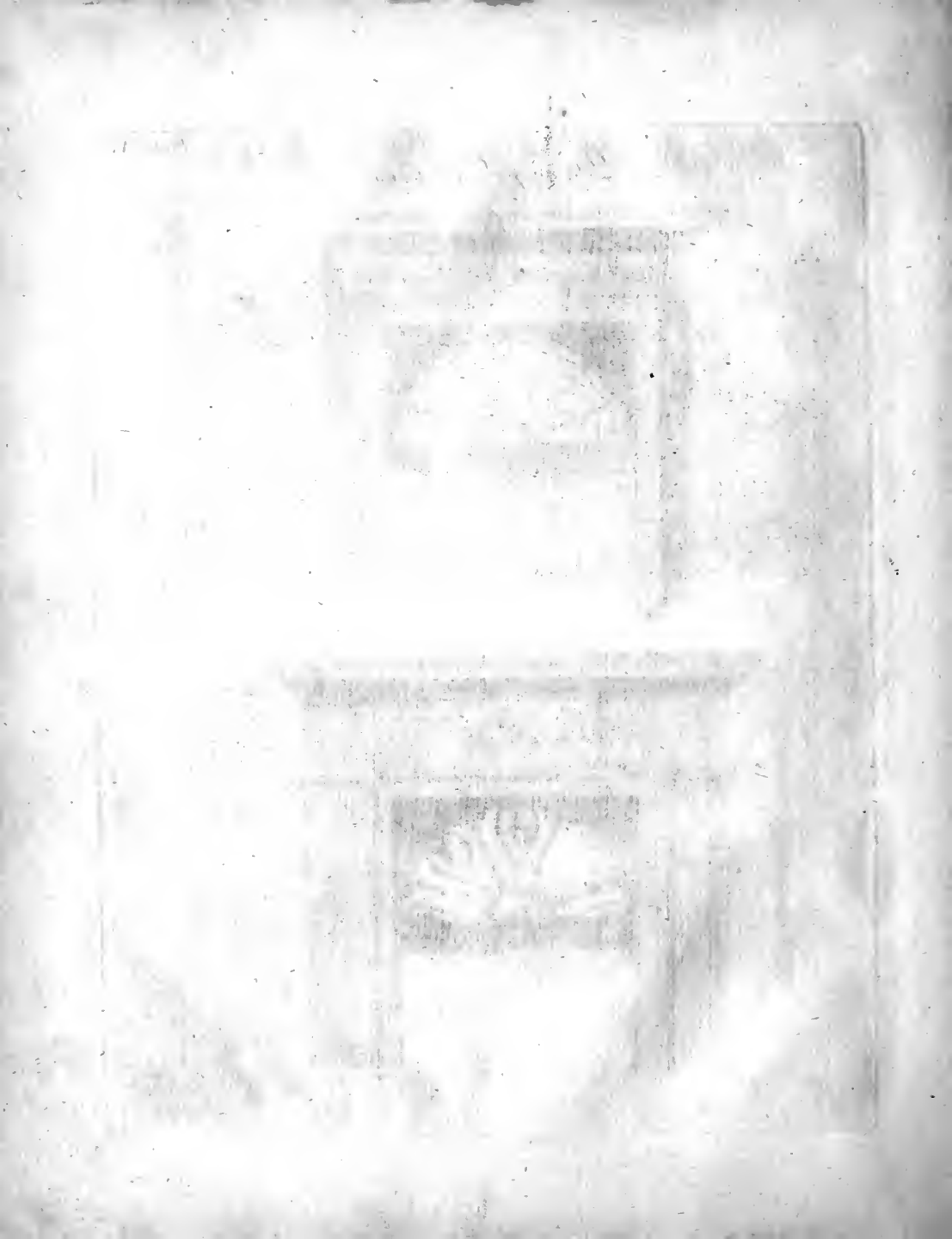

Door Cases for Rooms.

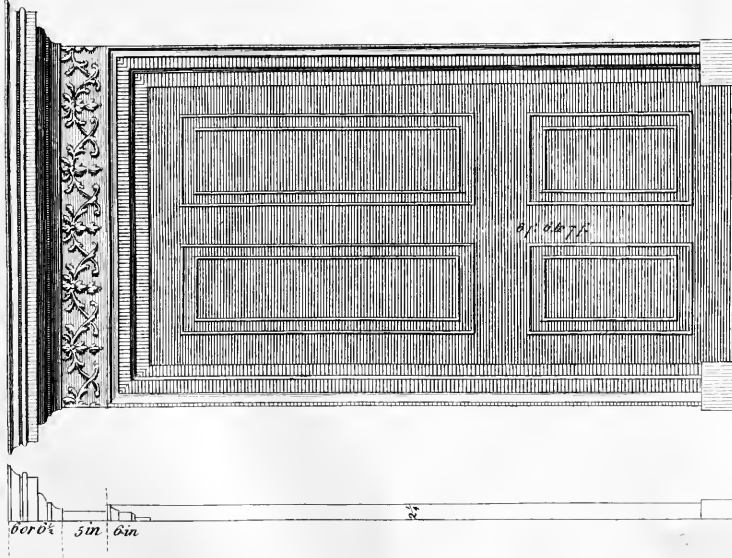
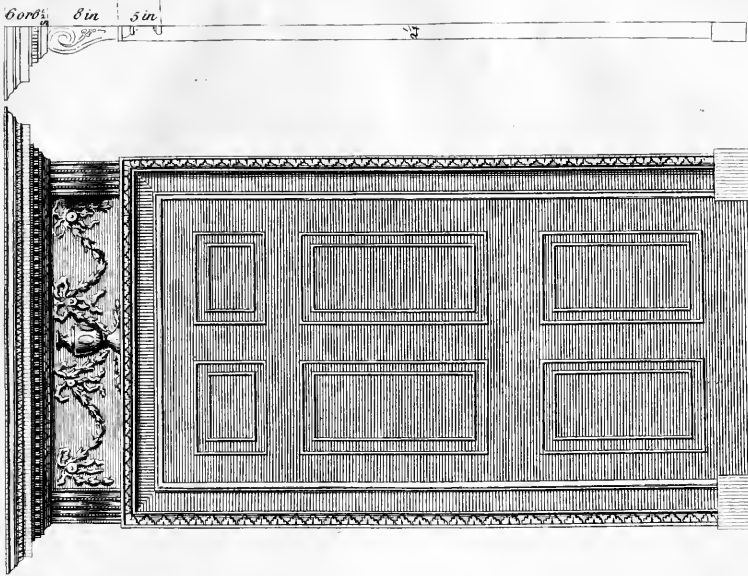



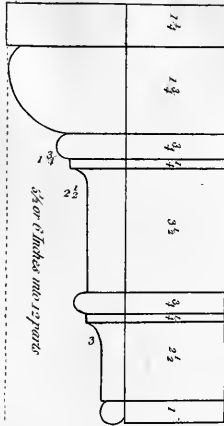
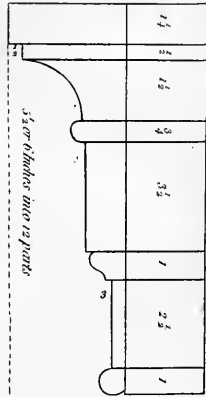

Architrave Mouldings
for Doors, Windows &c.

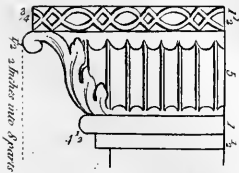
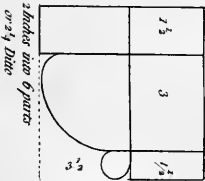
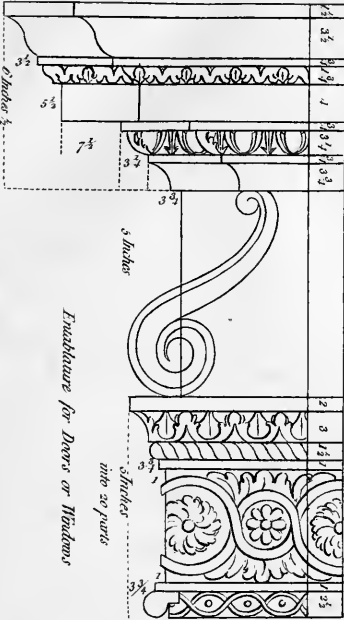
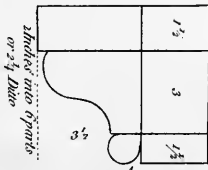
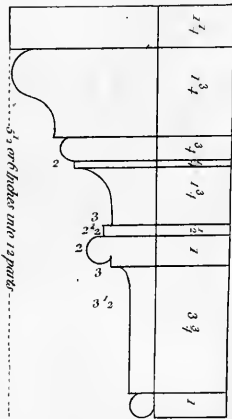

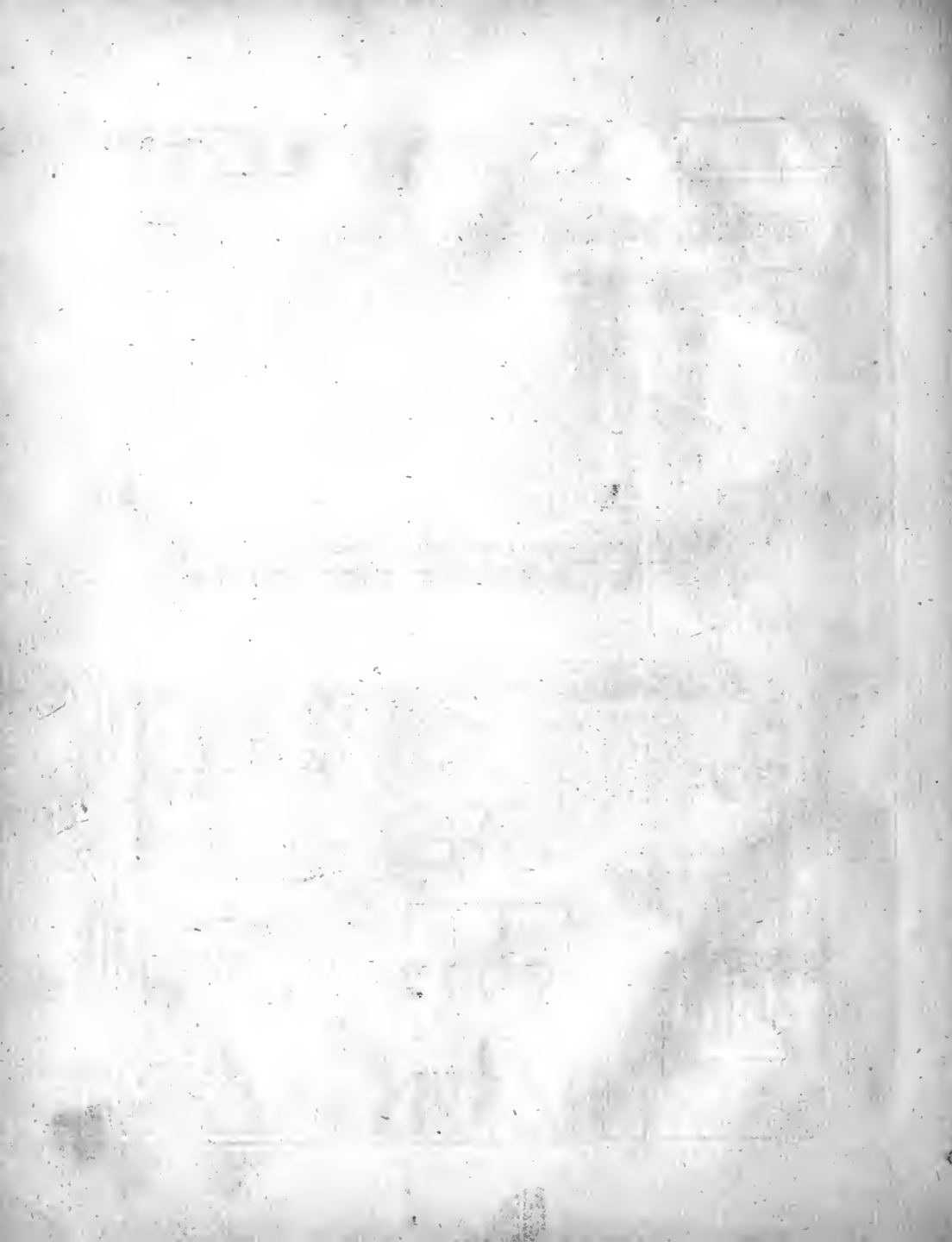

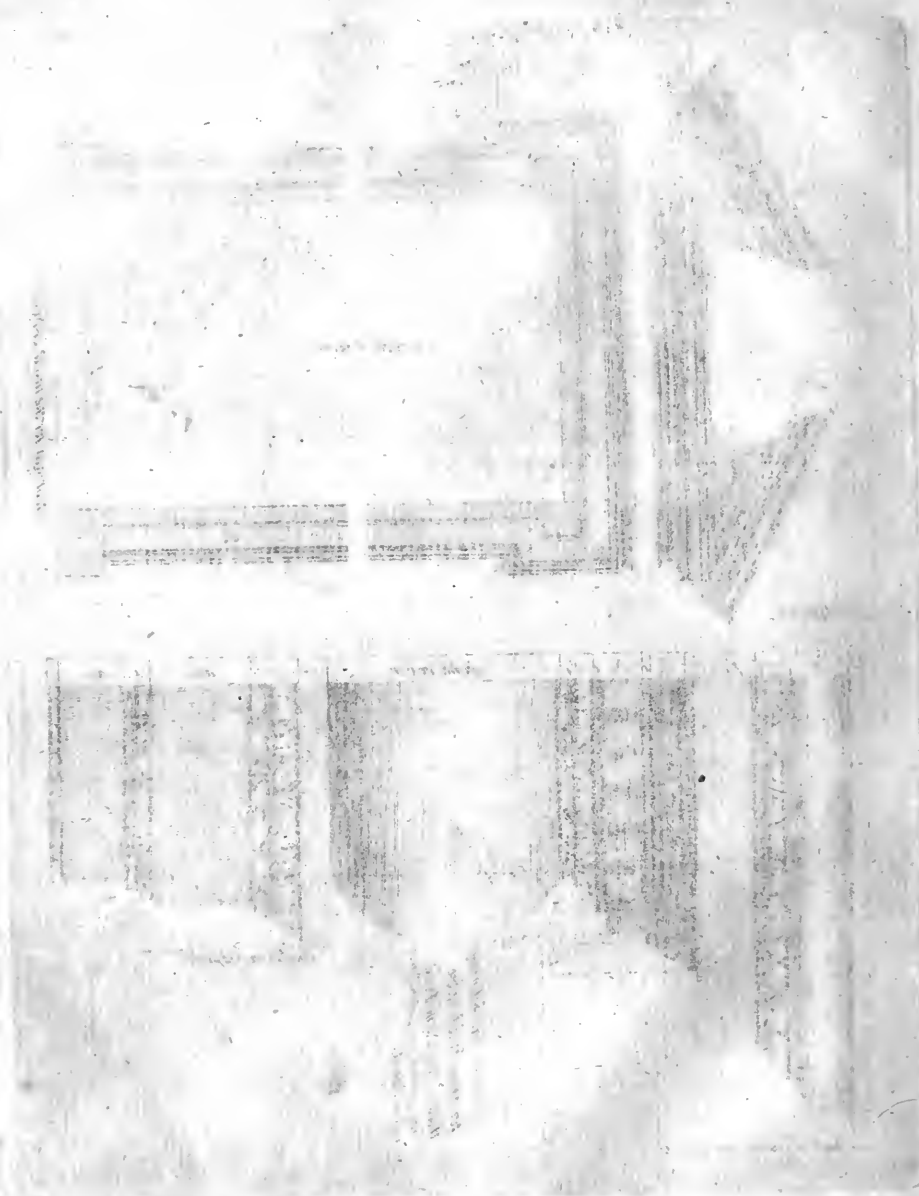

Half of a Compound open Pediment.

The whole Length of the Pediment on the Back is Divided into four parts, and the Cornice Returns at three of those parts.

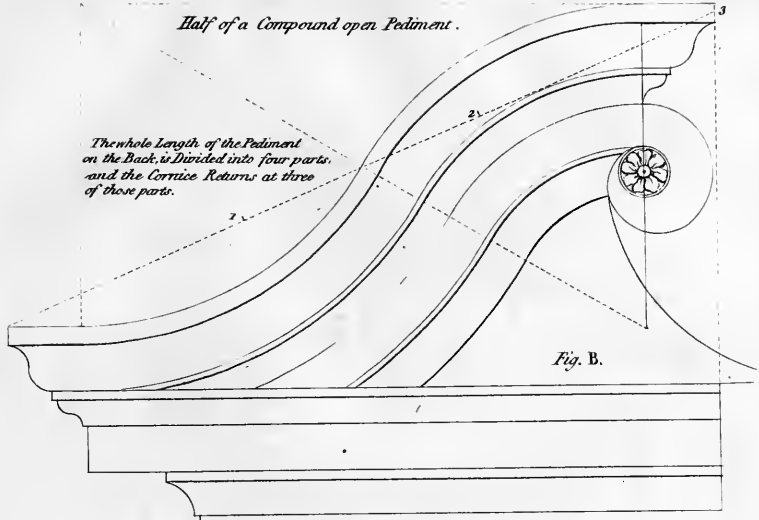

Open Pediments.

The Construction of Raking and Return Mouldings in Pediments the upper Part Fig. A. returns Perpendicular and the lower Part returns Square to the Back of the Pediment, the Centers are at Right Angles with the Projection & all Projecting alike, a b, b a & b a.

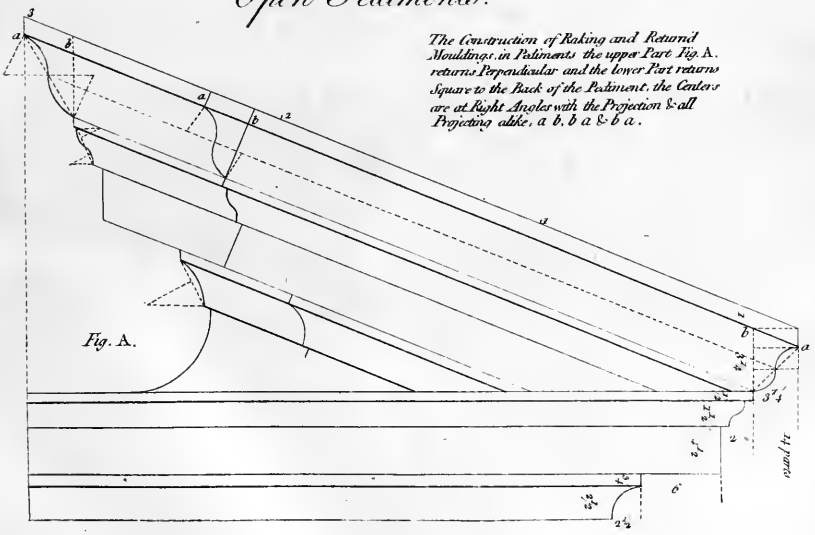

1774

the first of the year



the first of the year
 the first of the year
 the first of the year

the first of the year

the first of the year
 the first of the year
 the first of the year



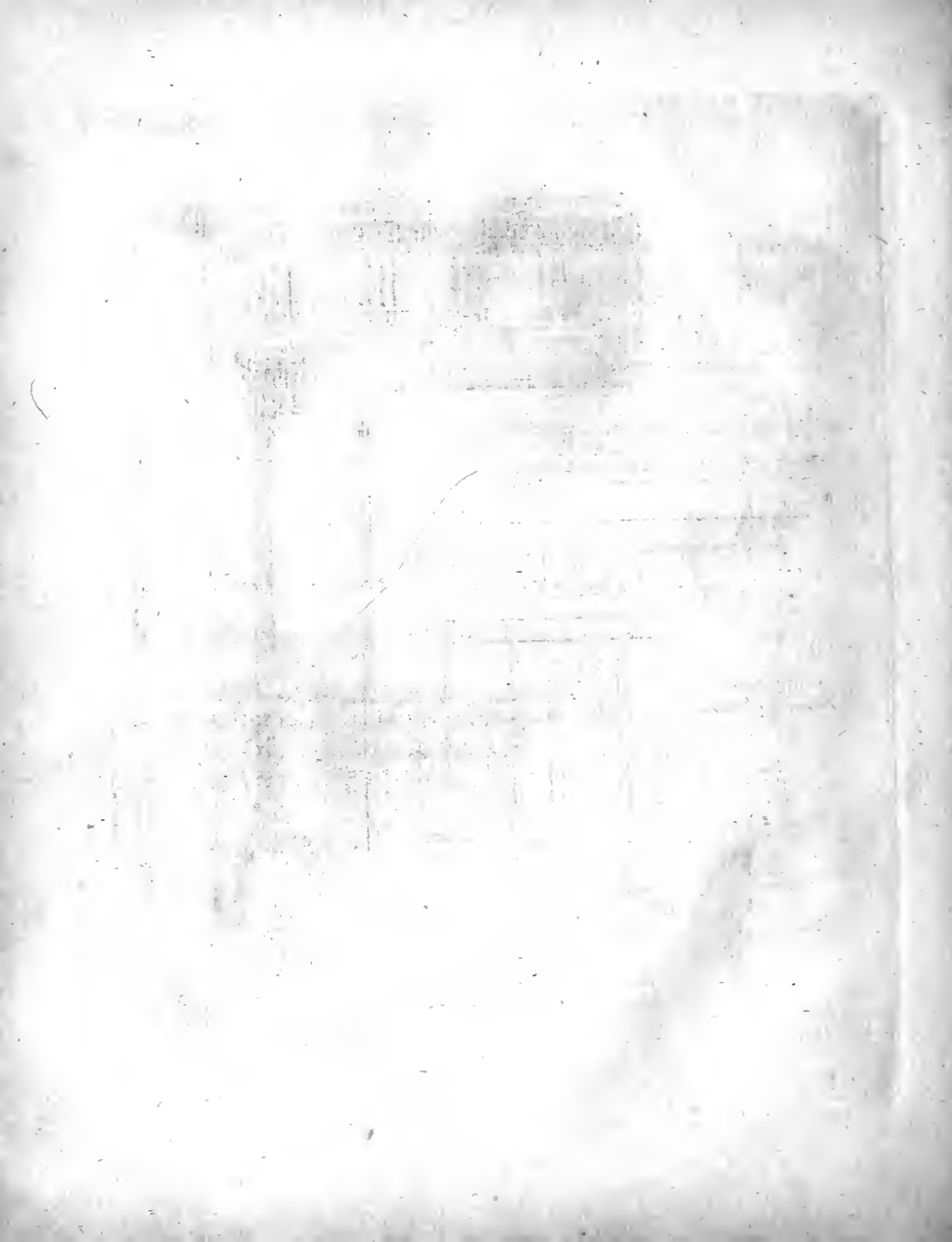

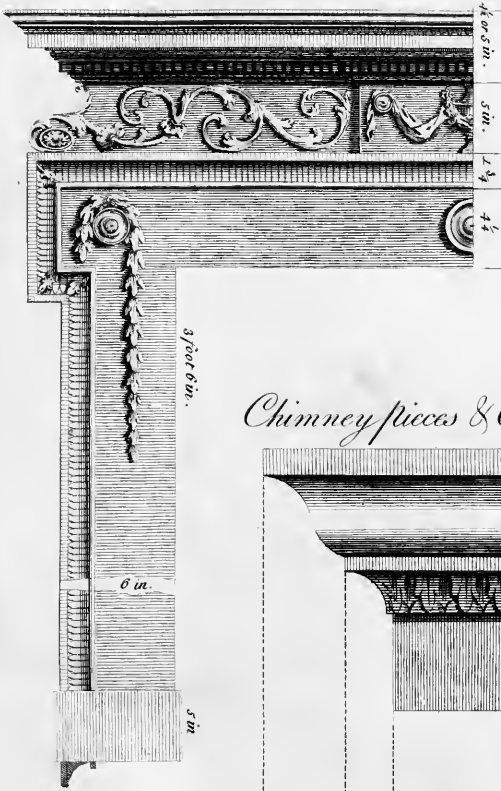

Chimney pieces & Cornice at Large

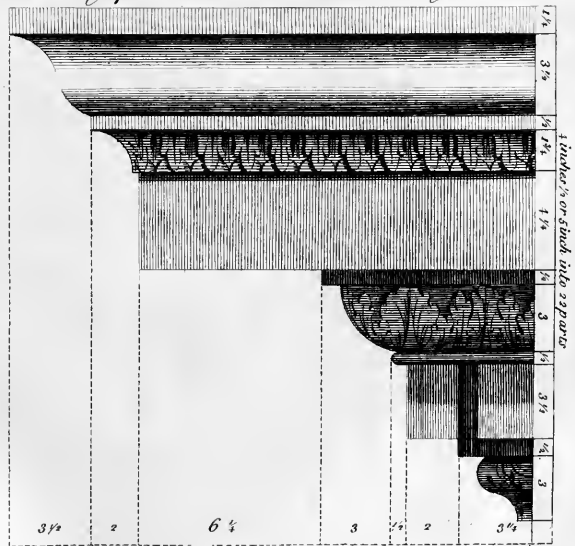

THE UNIVERSITY OF CHICAGO
LIBRARY

THE UNIVERSITY OF CHICAGO
LIBRARY

THE UNIVERSITY OF CHICAGO
LIBRARY

Two Chimney Pieces with open Pediment, Glass or Picture-frames ornamented.

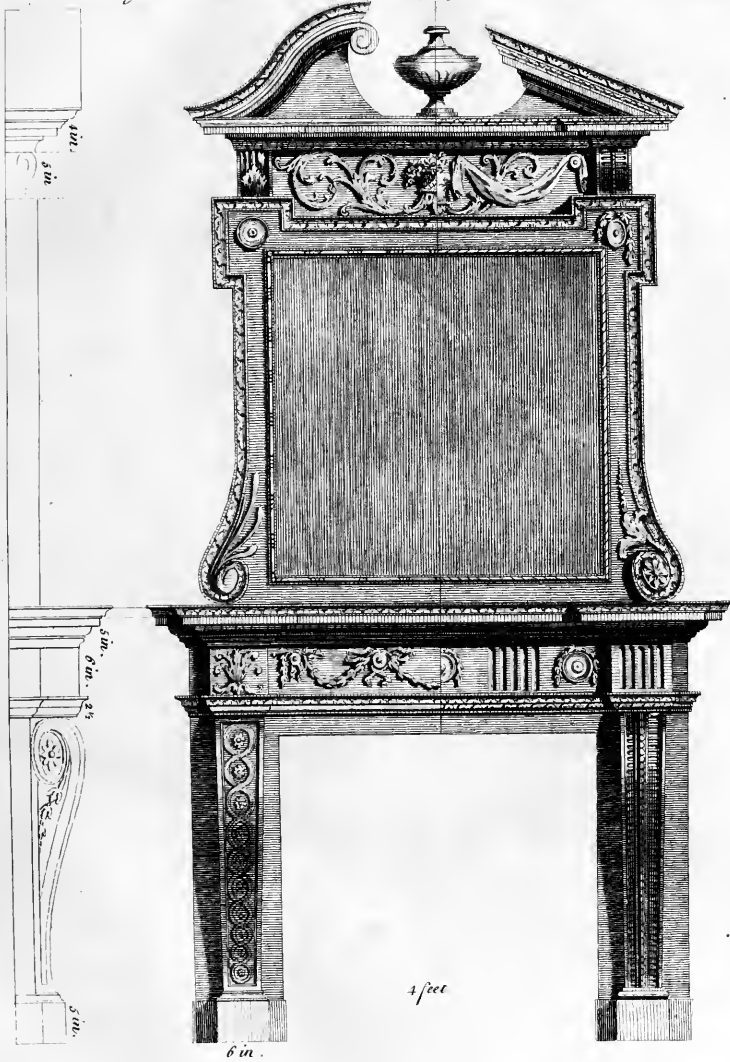

179

Handwritten text at the top of the page, possibly a title or header, which is mostly illegible due to fading.

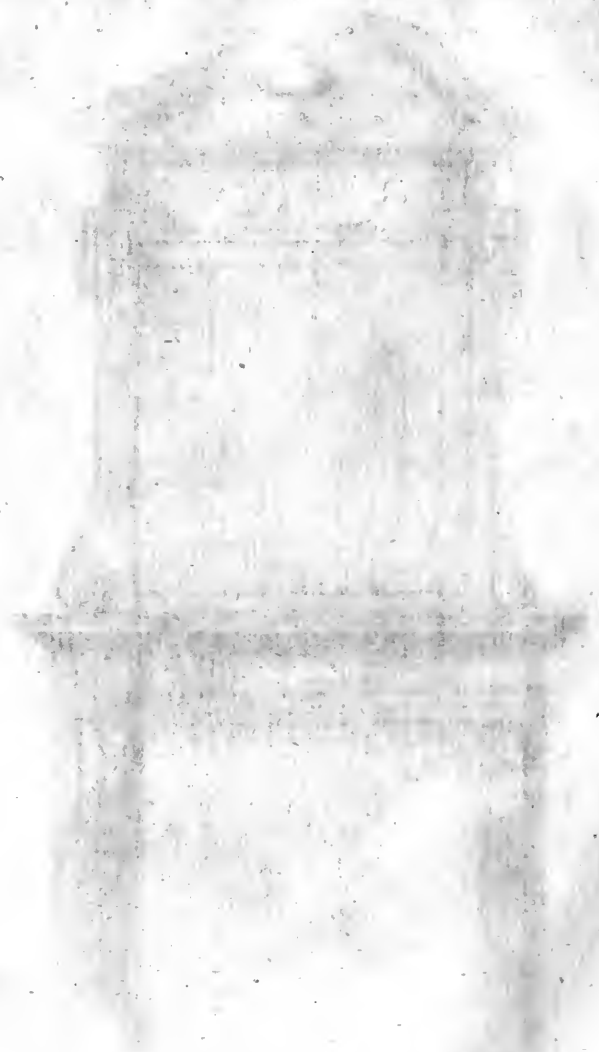

Two Designs for Chimneys with Caryattic Figures.

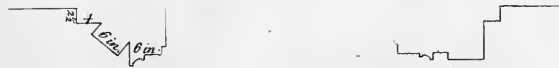

Cornice at large.

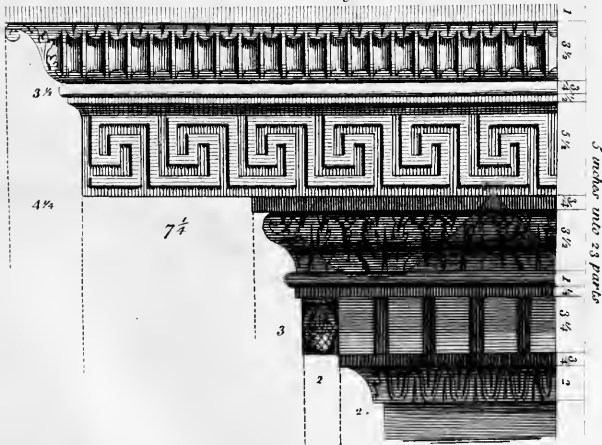

THE UNIVERSITY OF CHICAGO

PHYSICS DEPARTMENT

PHYSICS 351

LECTURE 10

Two Designs for Chimney pieces.

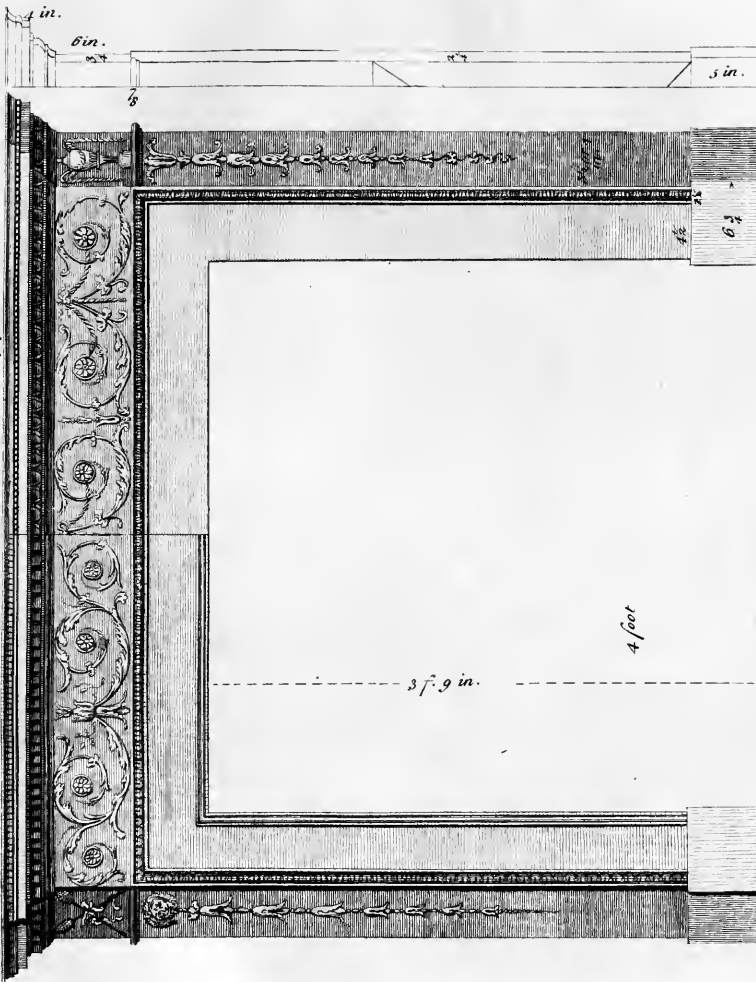

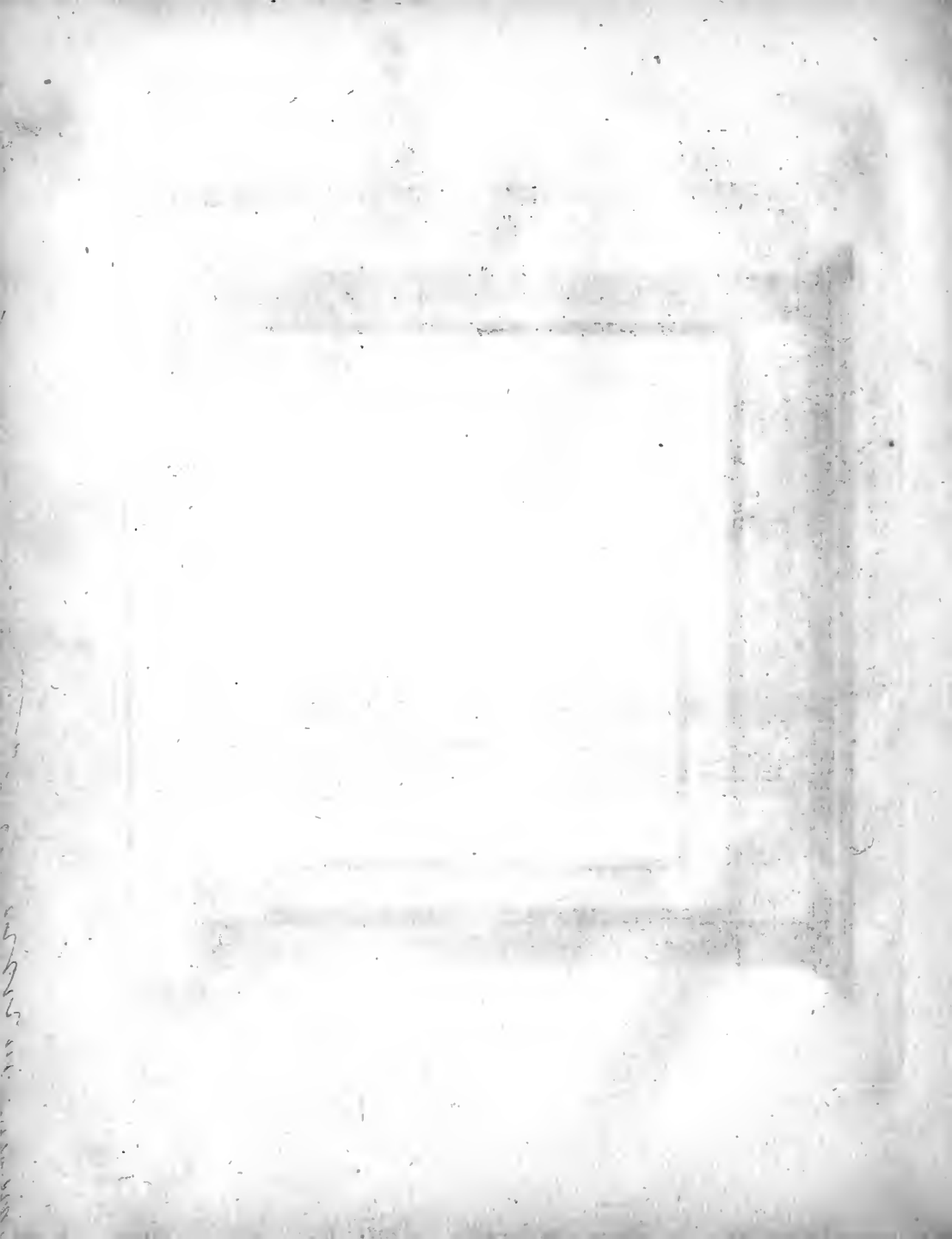

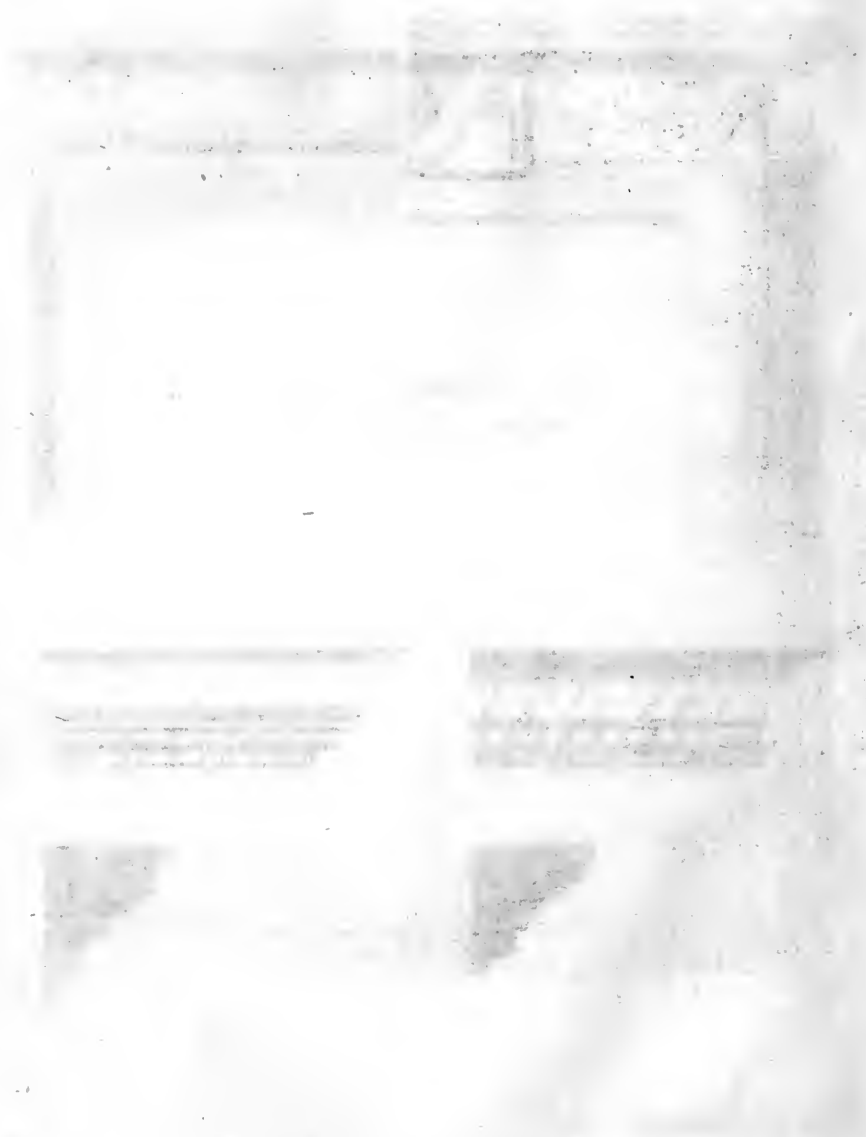

Two Designs for Chimney Pieces.

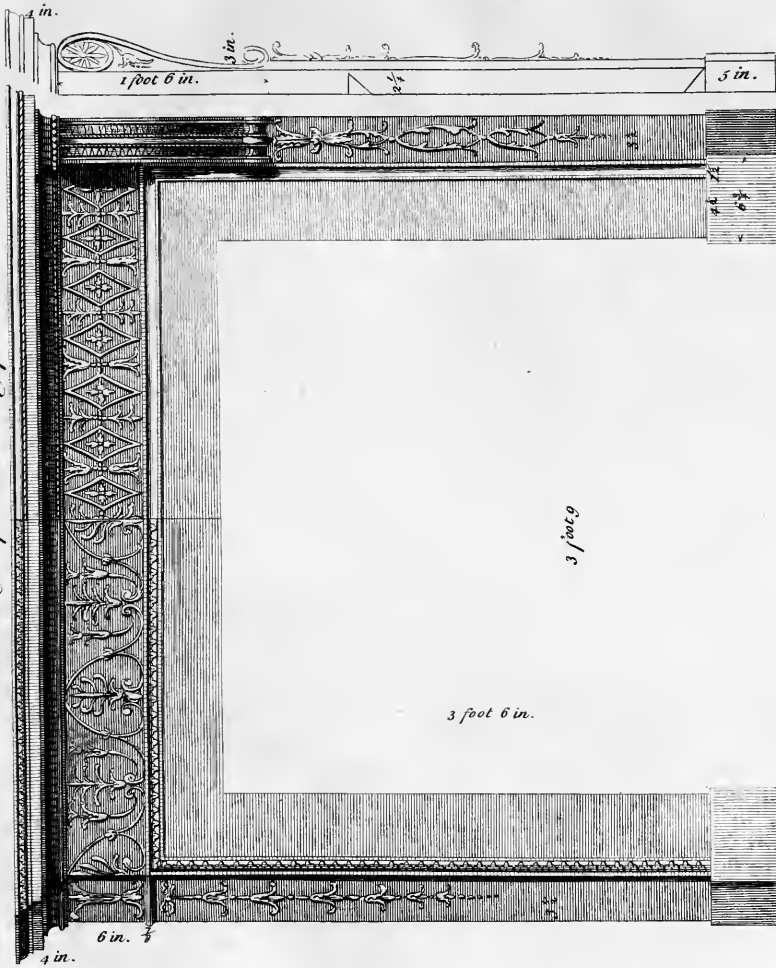

1875

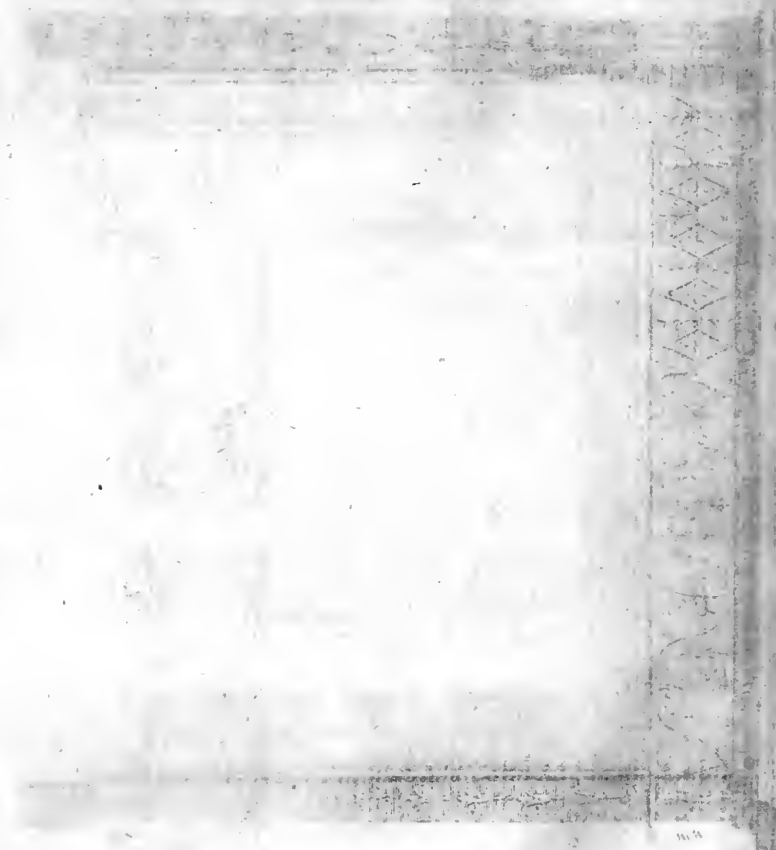

THE UNIVERSITY OF CHICAGO

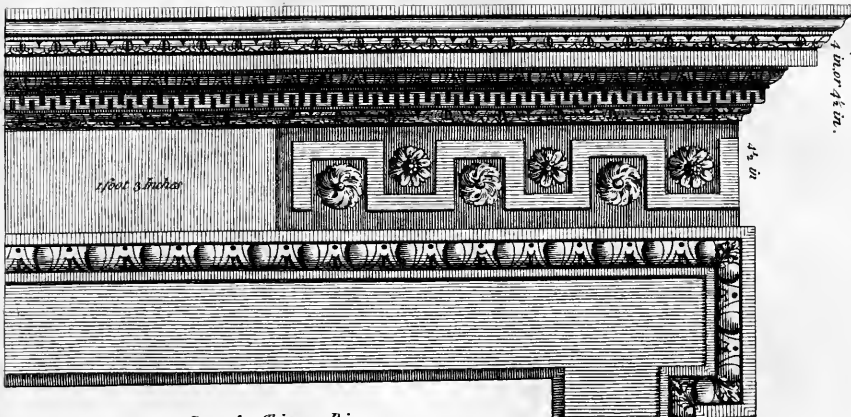

*Part of a Chimney-Piece
with Architrave, Frieze and Cornice.*

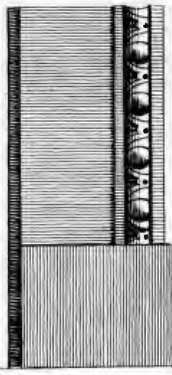
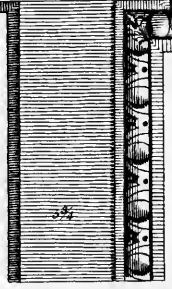
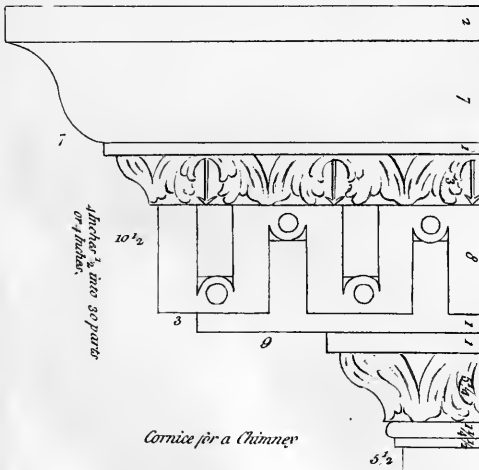

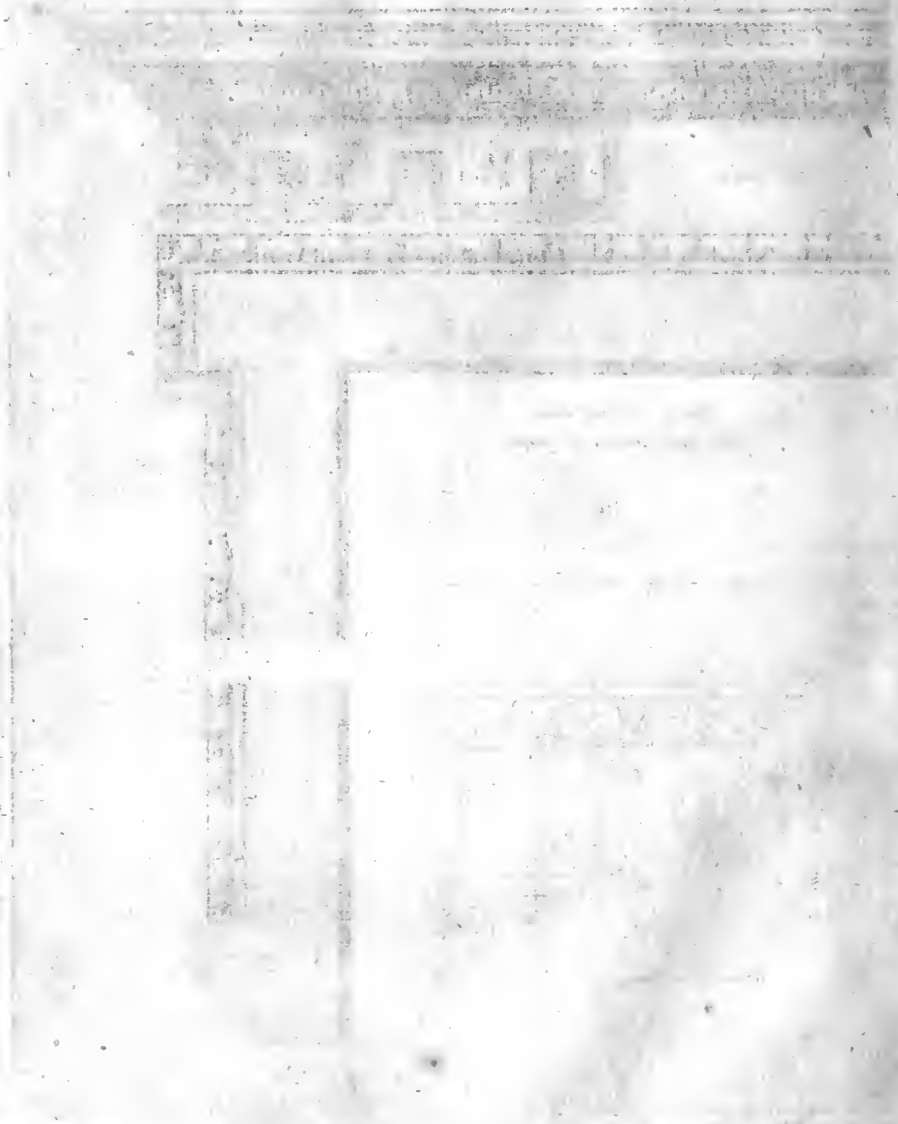

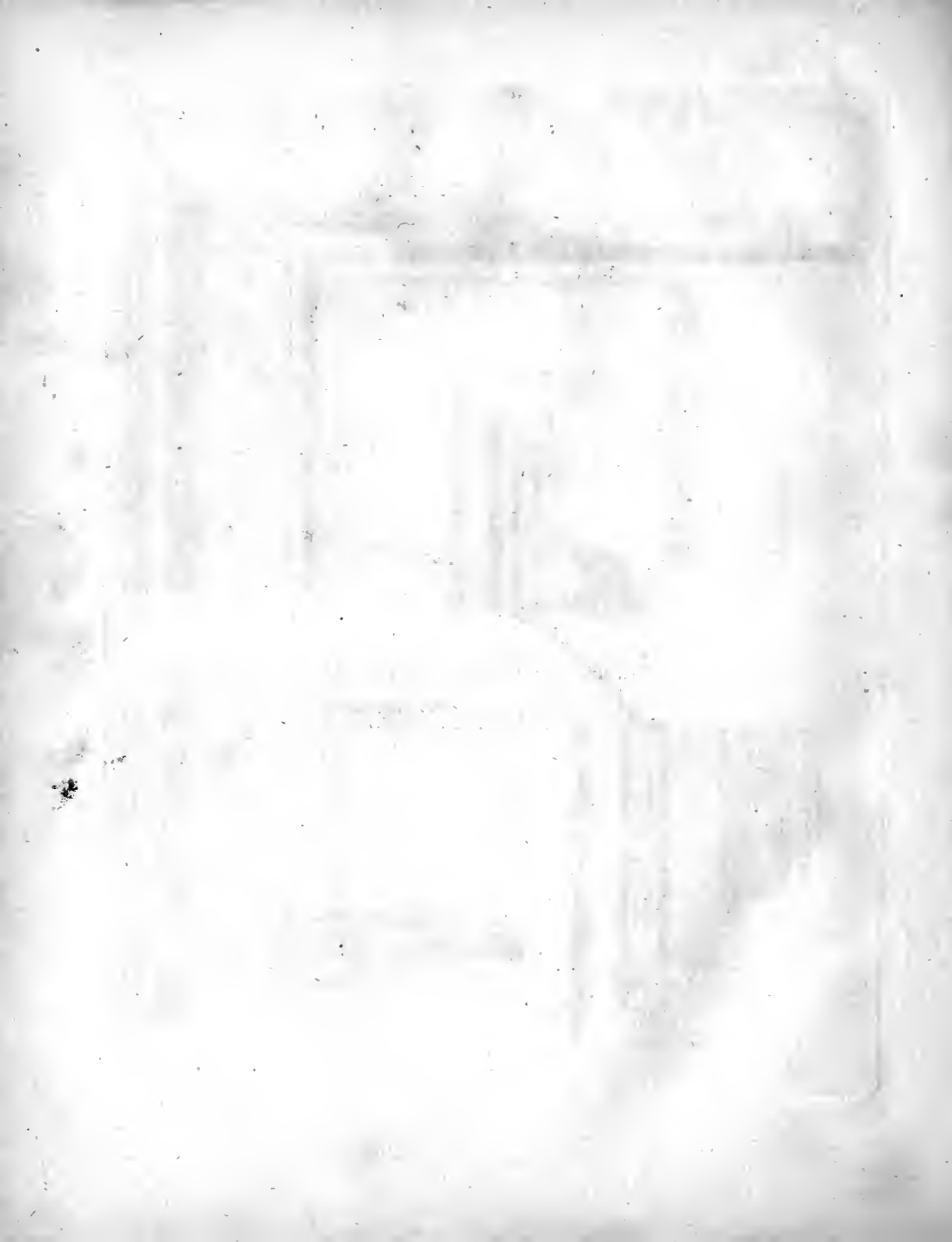

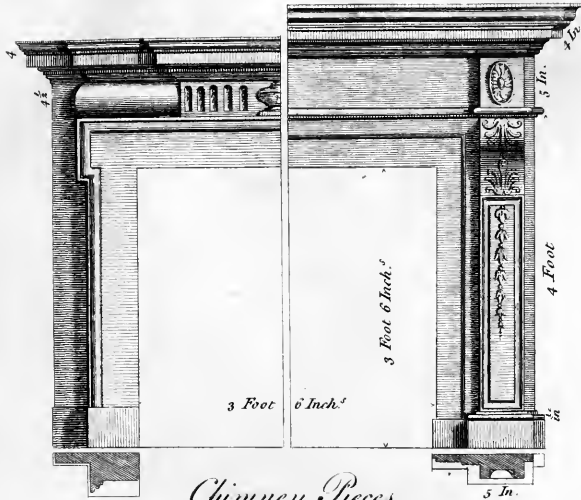

Chimney Pieces.

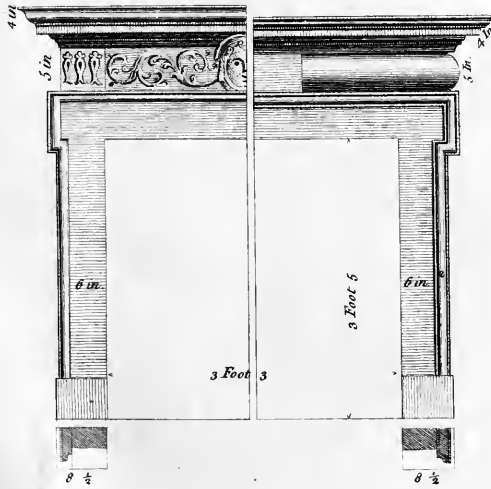



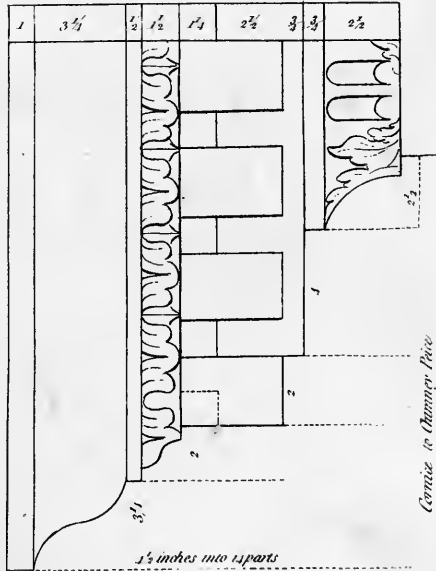
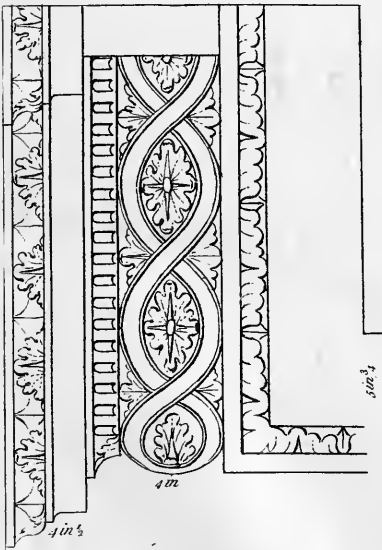
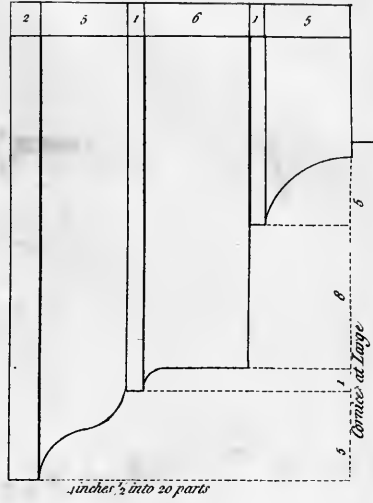
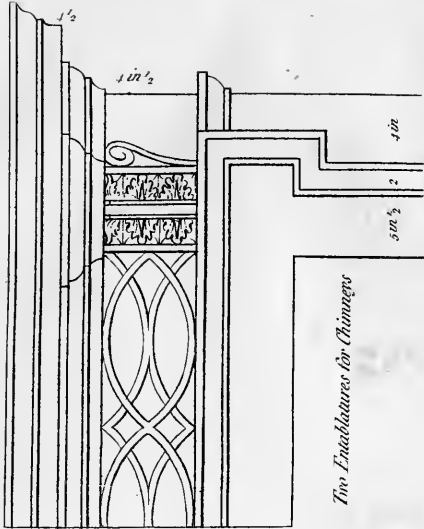
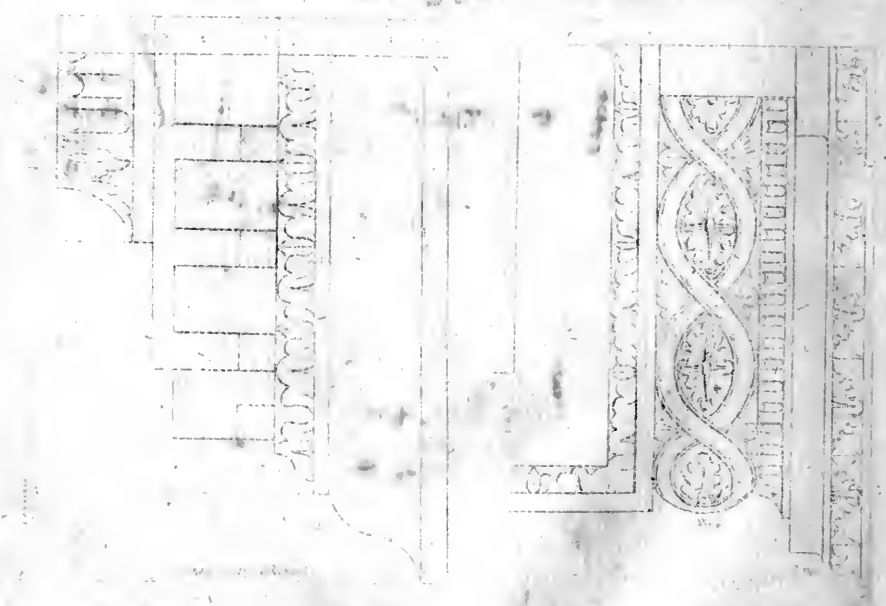
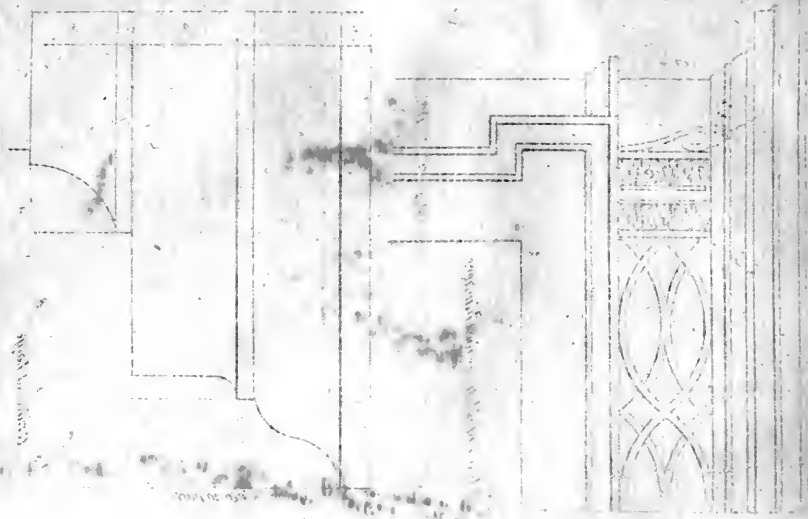
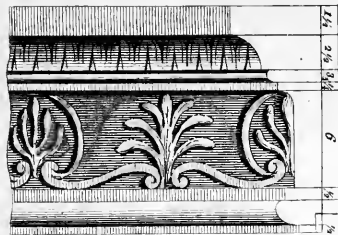
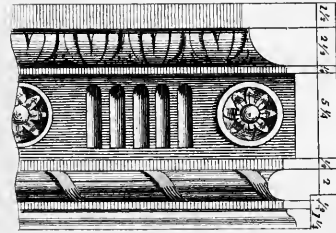
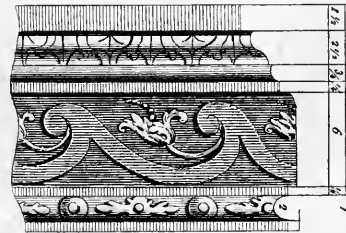
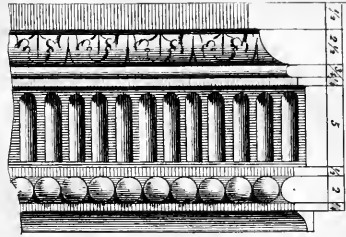

PLATE 1



Mouldings for Looking Glass or Picture Frames.



Each moulding 11 Parts.



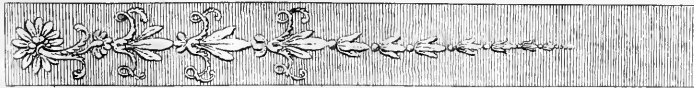
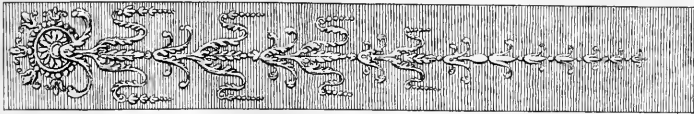
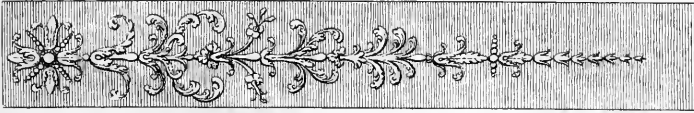
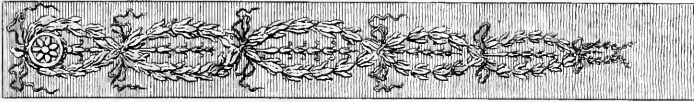

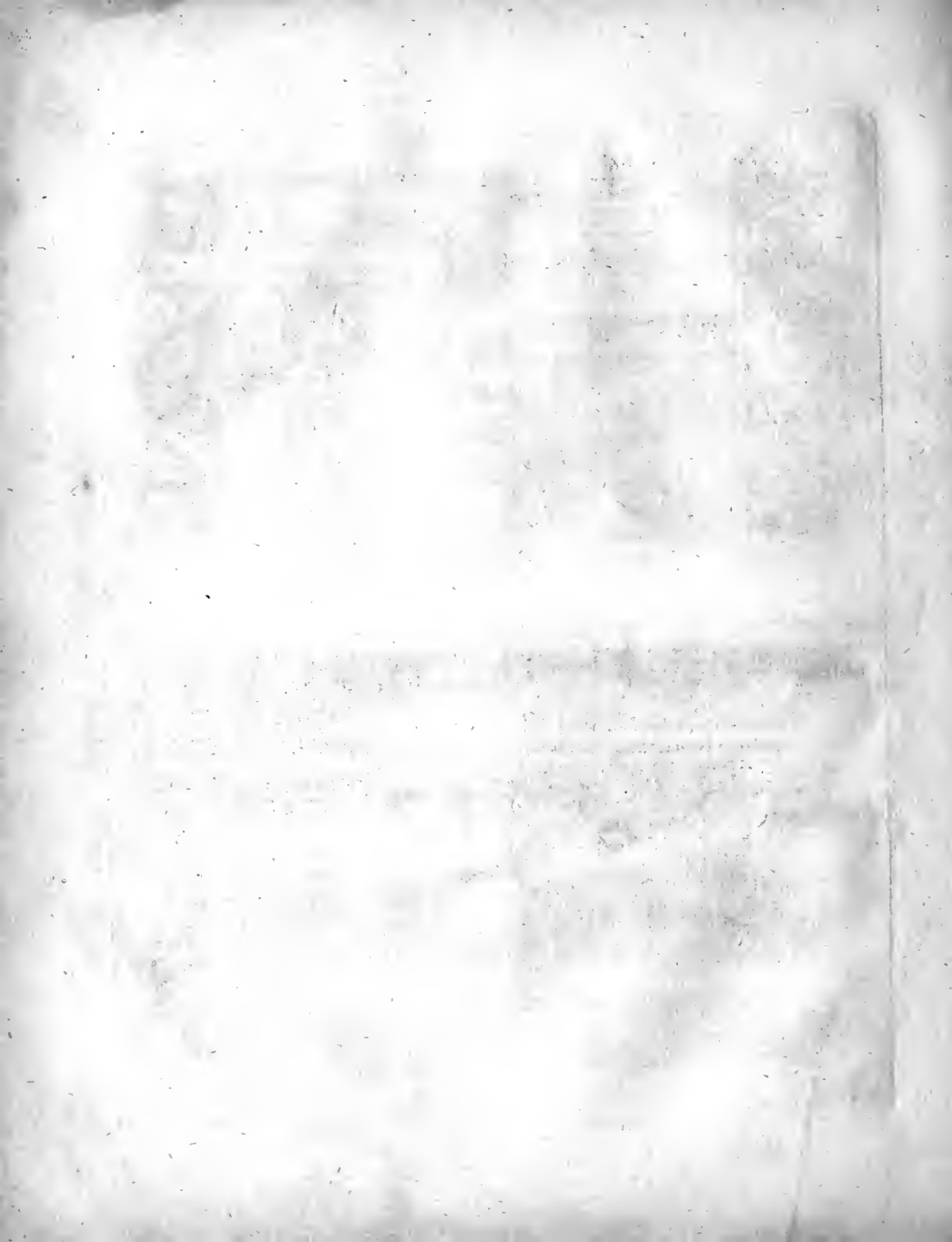

Handwritten mark or signature on the left margin.

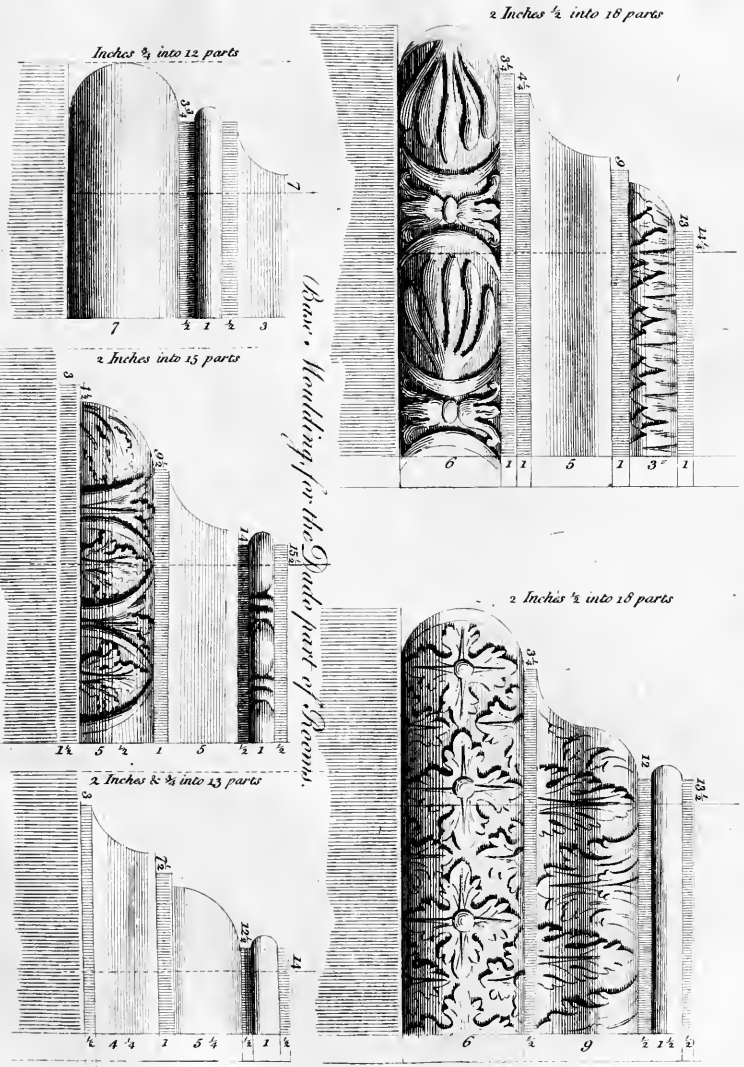

THE
MUSEUM

OF
NATURAL HISTORY

AND
ZOOLOGY

OF
THE
CITY OF
NEW YORK

NEW YORK: PUBLISHED BY THE MUSEUM, 1000 MUSEUM AVENUE, 1900.

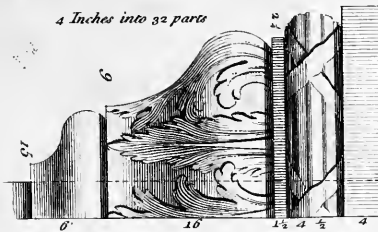
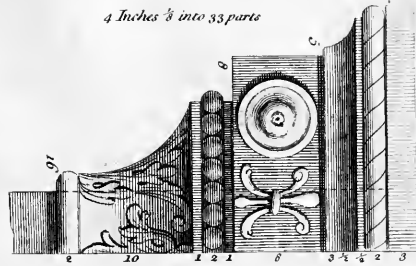
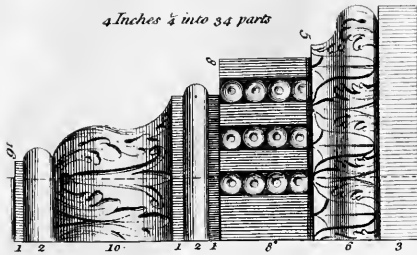

Subbases for the Orders of *Norman* &c.

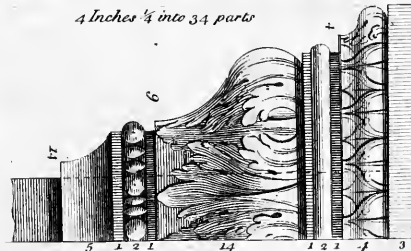
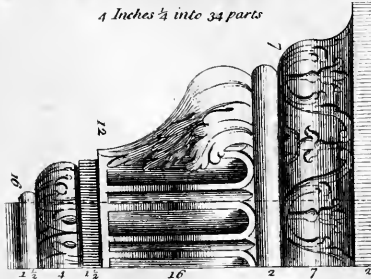
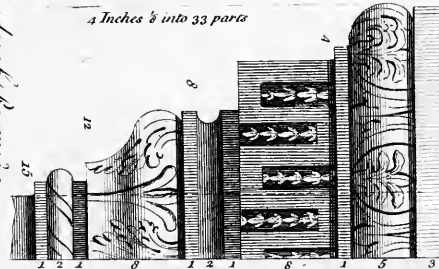
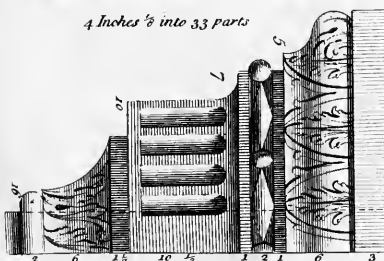
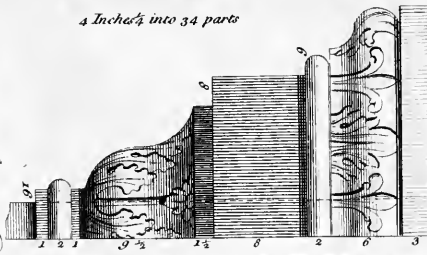

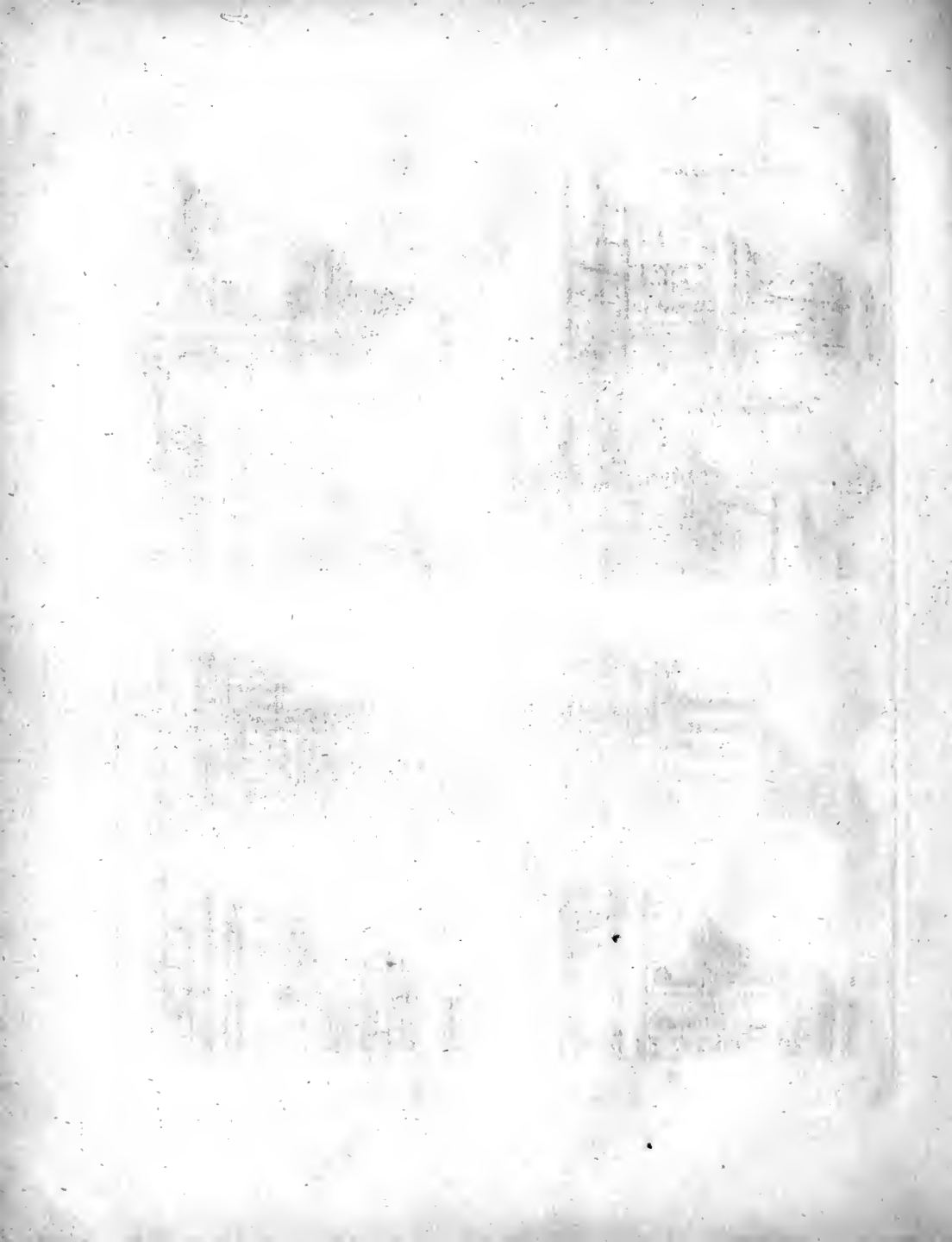

1875

1875

1875

1875

1875

1875

1875

1875

1875

1875

1875

1875

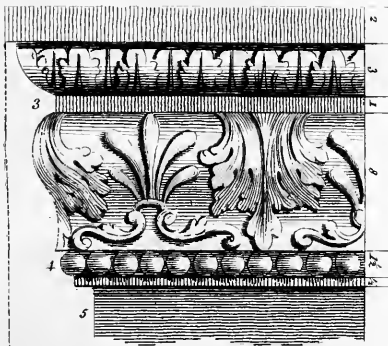
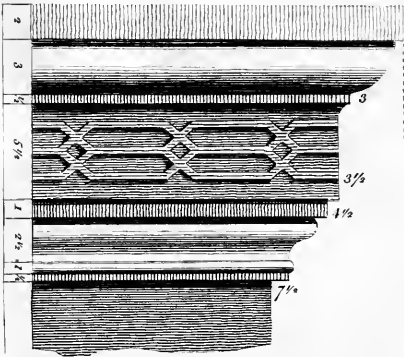
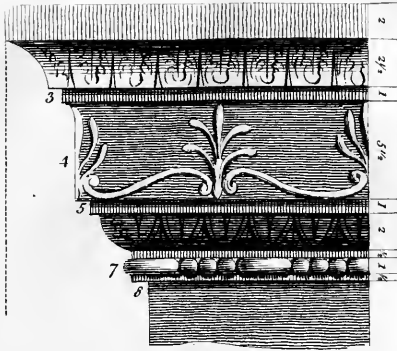

4 inches into 16 parts

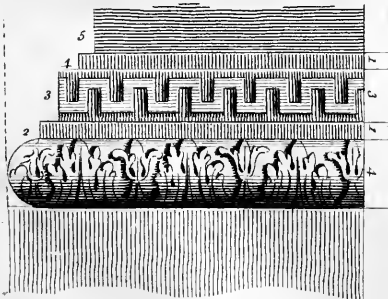
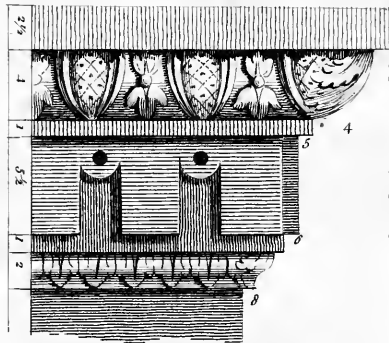

2 1/4 inches into 9 parts
2 inches diam

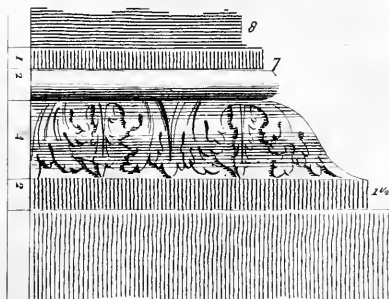

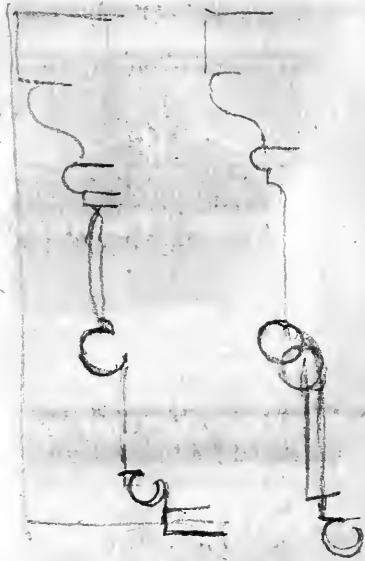

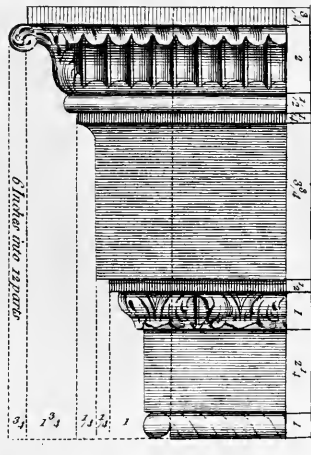
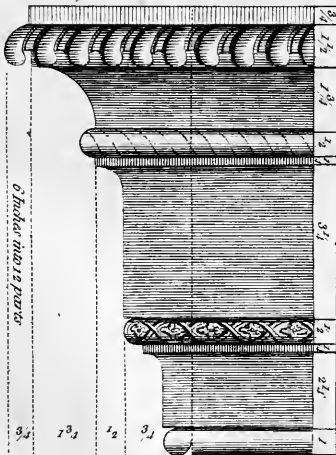
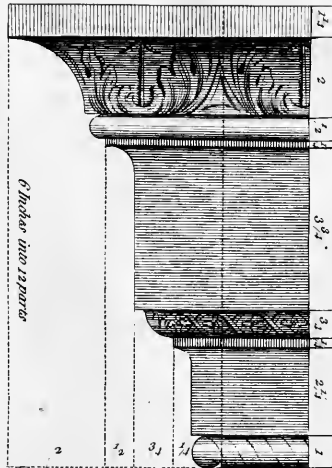
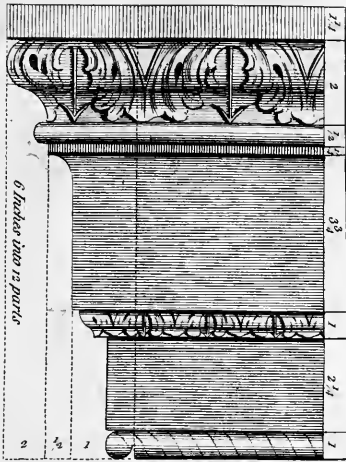

Architraves for Doors Windows &c. at large.

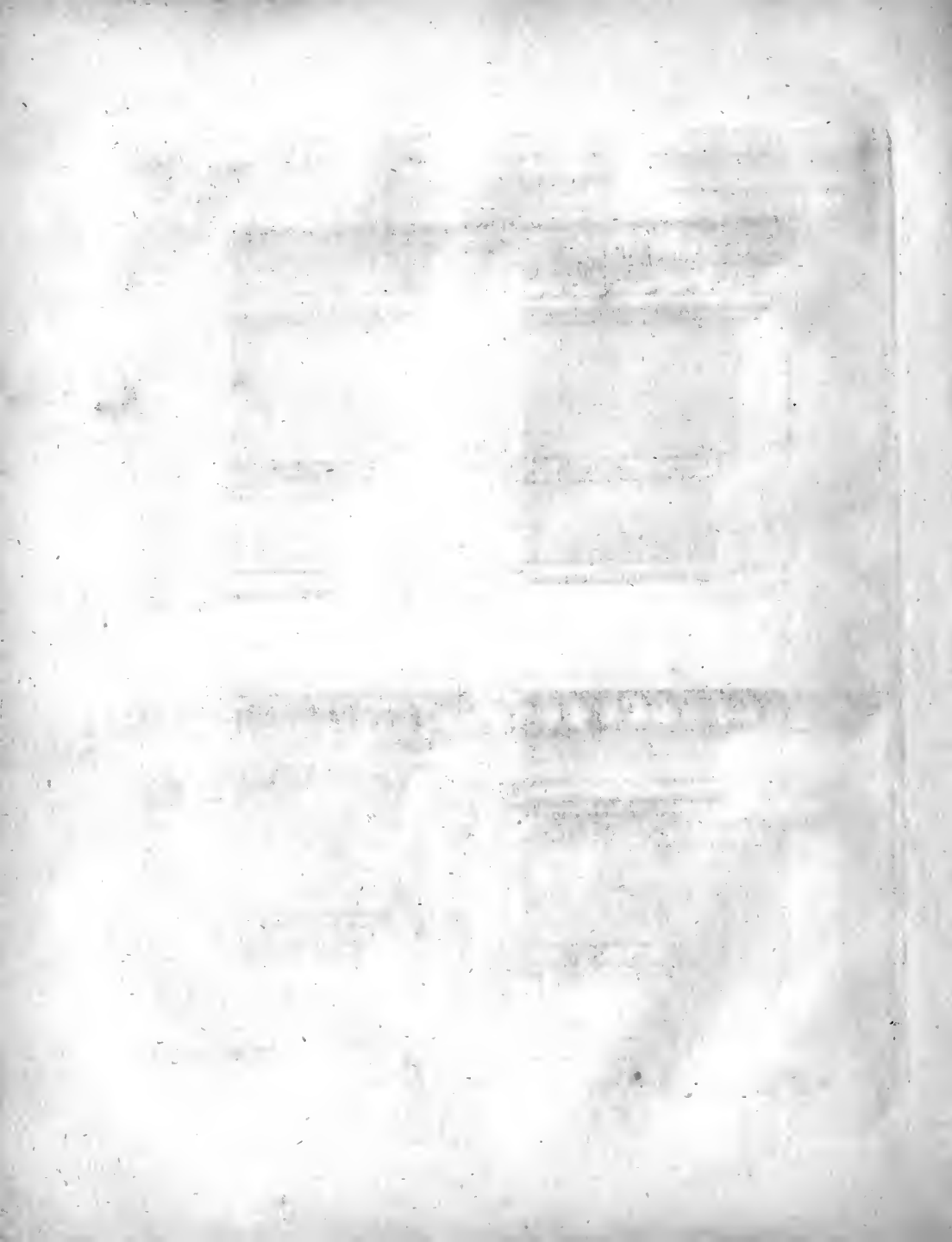

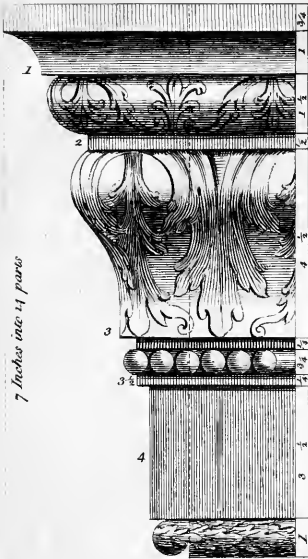

7 Inches into 14 parts

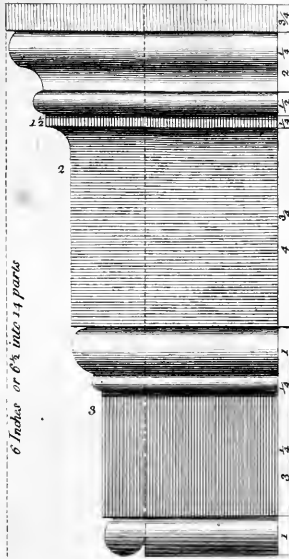

6 Inches or 6 1/2 into 14 parts

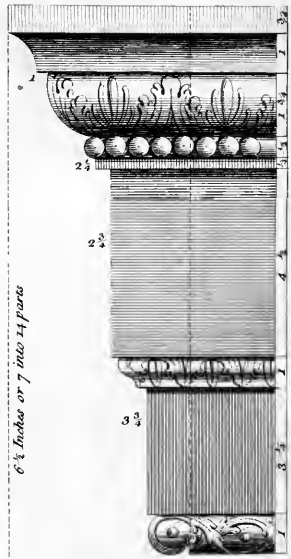

6 1/2 Inches or 7 into 14 parts

Architraves for Doors Windows &c.

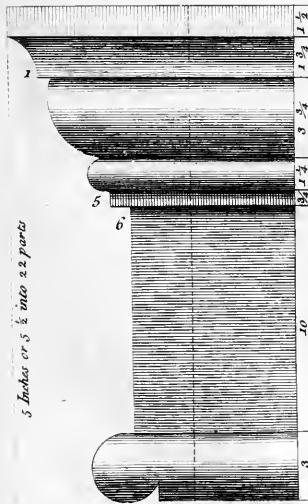

5 Inches or 5 1/2 into 22 parts

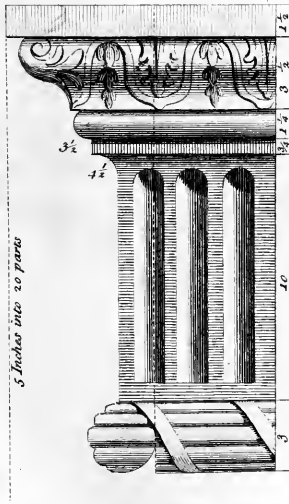

5 Inches into 20 parts

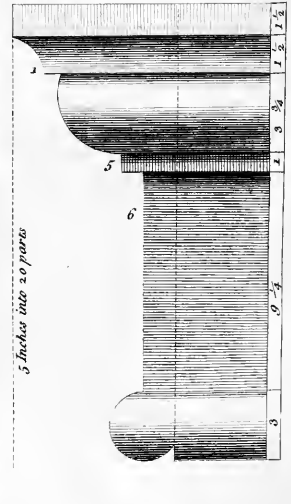

5 Inches into 20 parts

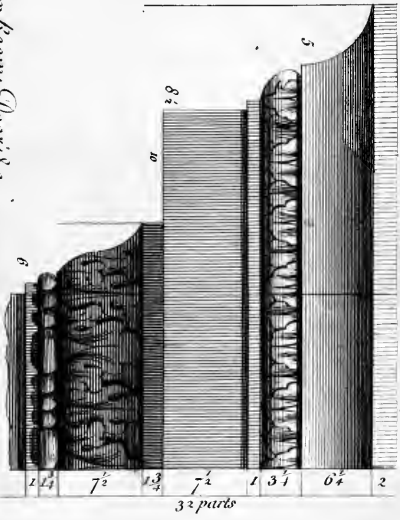
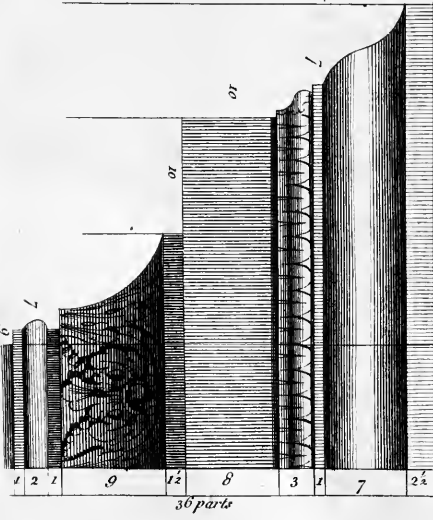
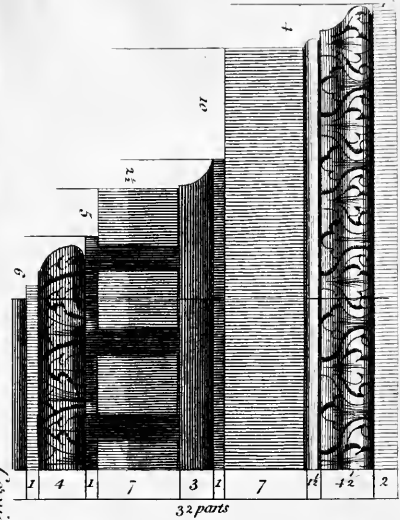
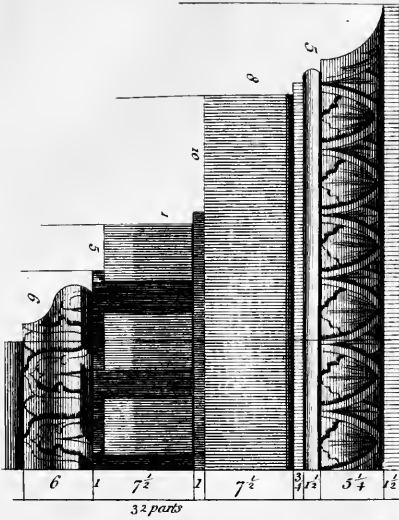

Dimensions for Horns, Danish.

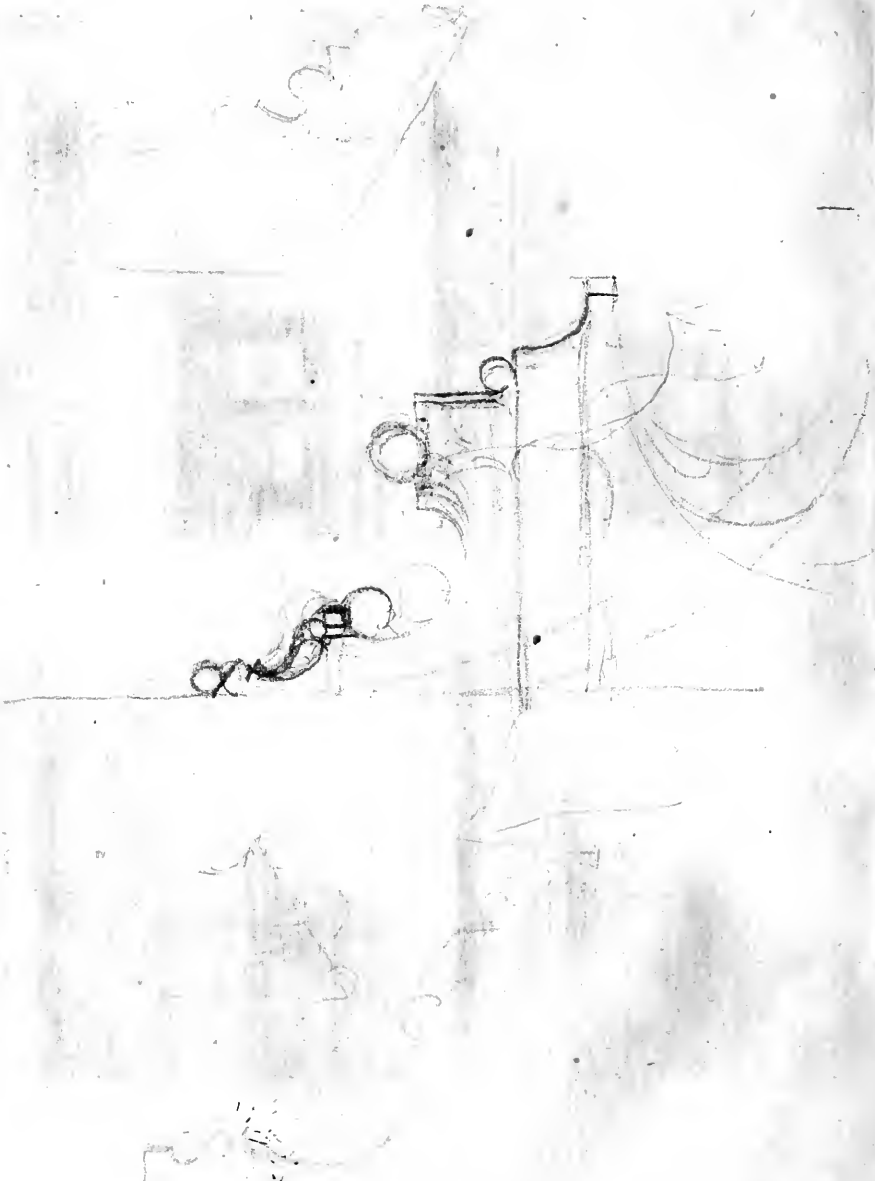

For Rooms 18 part of the whole height. For Doors from 6 to 7 inches. For Chimneys from 4 inches to 4 1/2.

Cornices for Rooms, Doors &c.

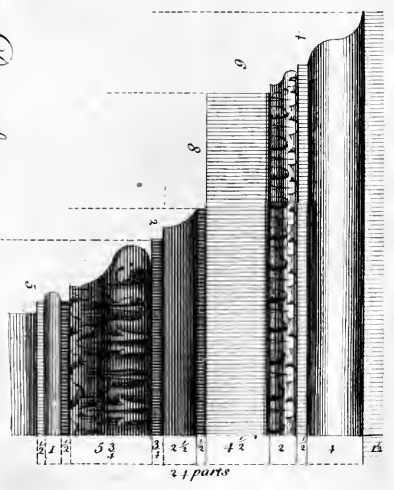
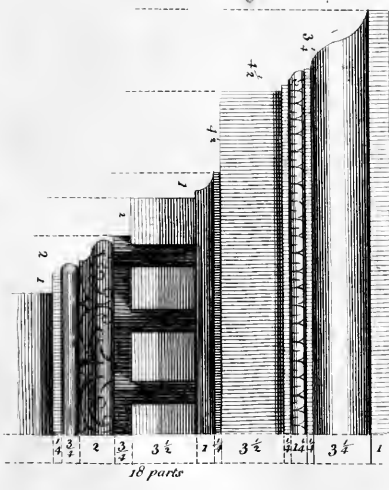
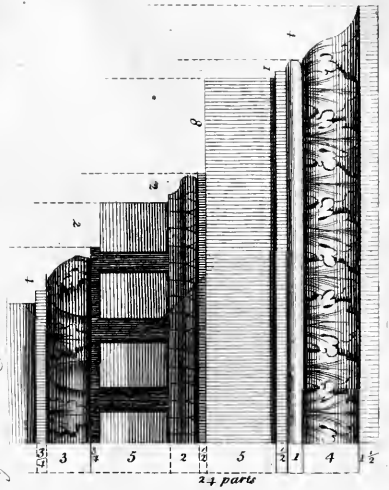
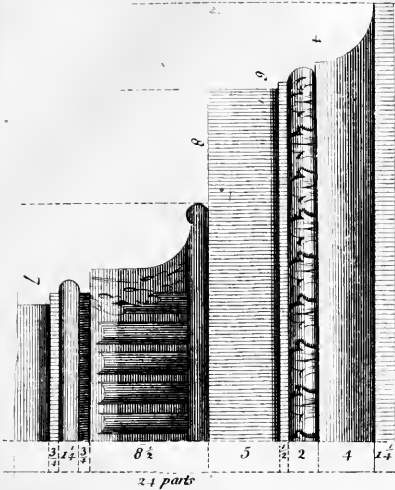

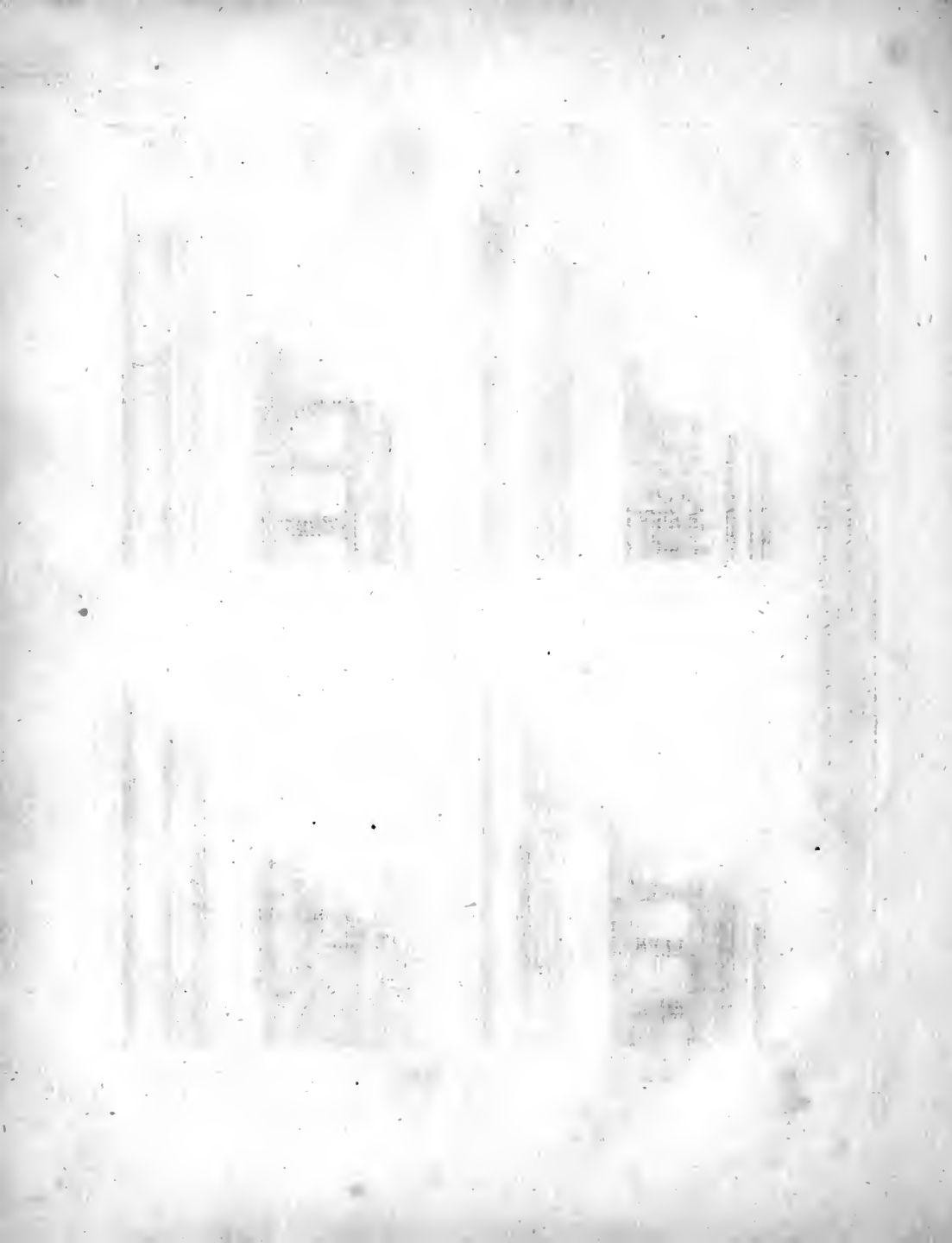

Cornices for Rooms &c.

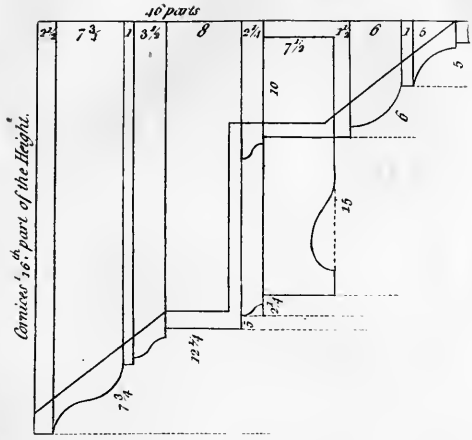
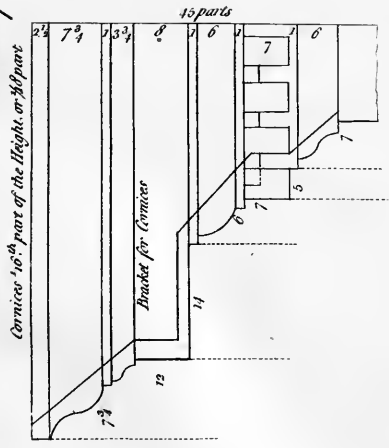

Cornice $\frac{1}{16}$ th or $\frac{1}{16}$ th part of the Height for Rooms &c.

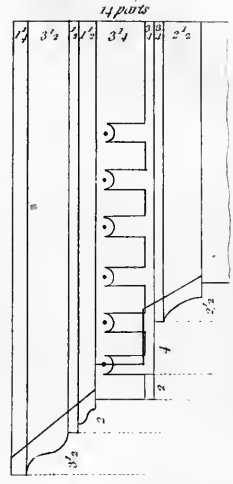
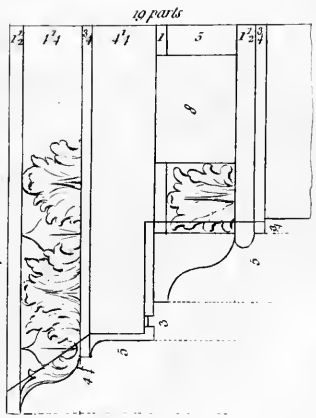

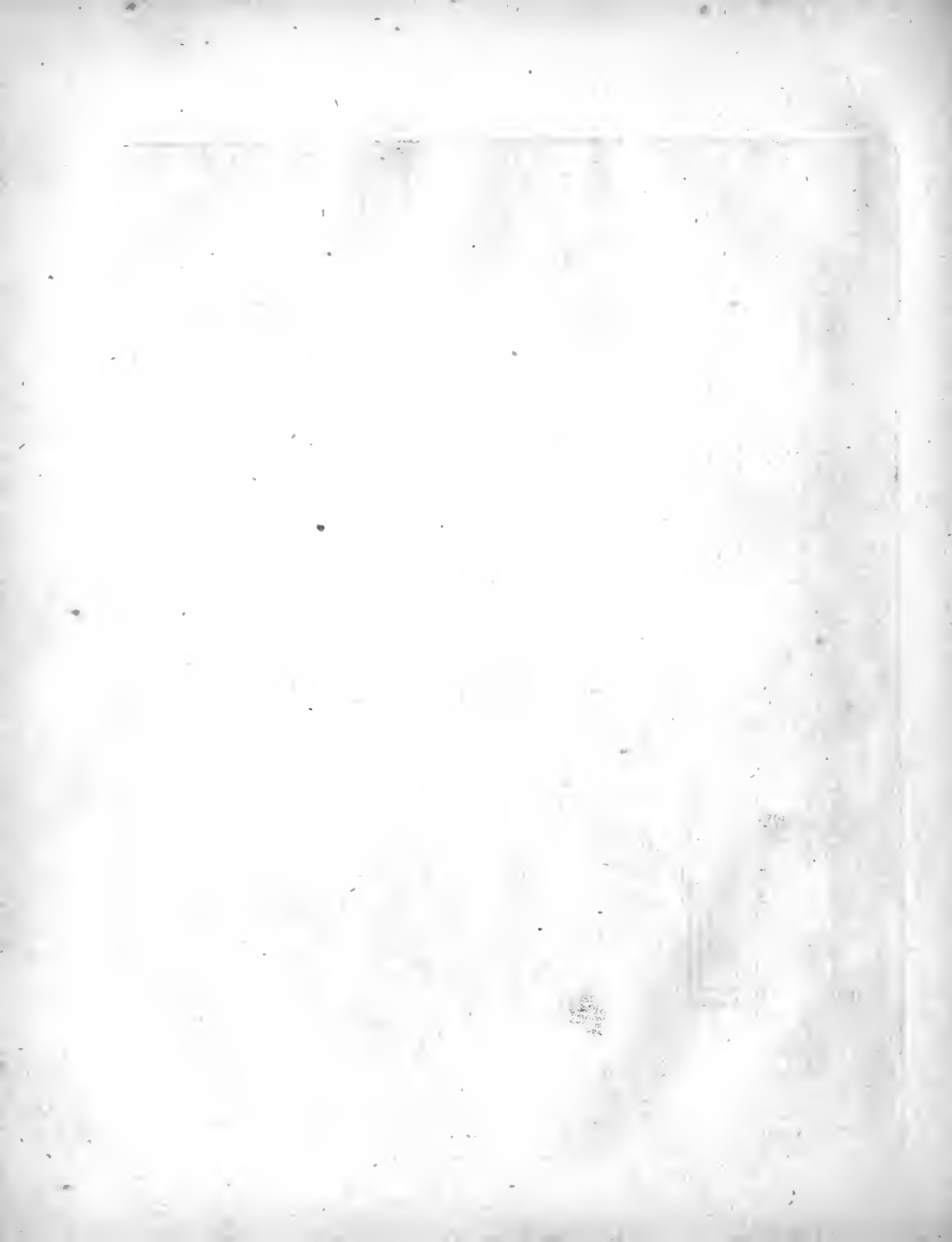

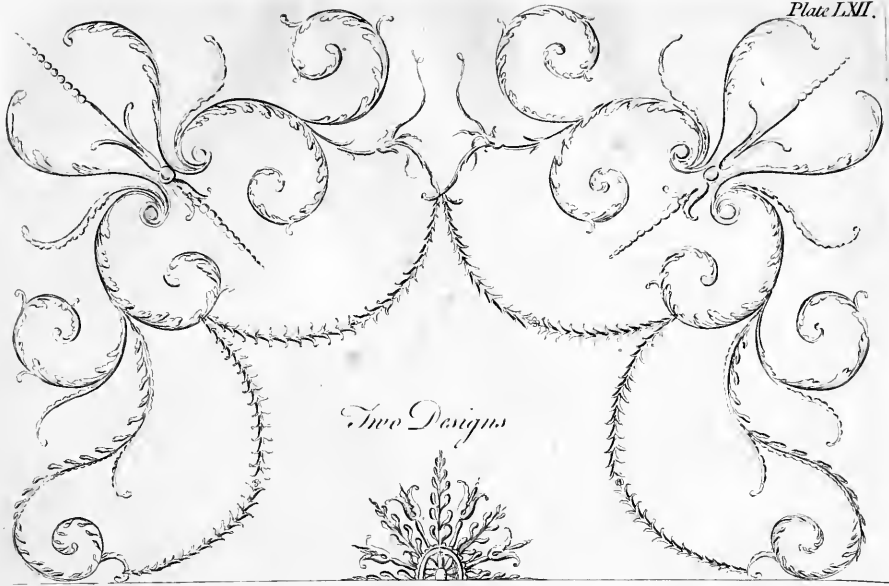

Two Designs

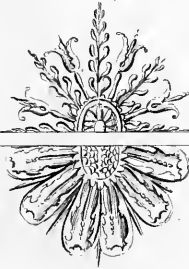

for Ceilings.





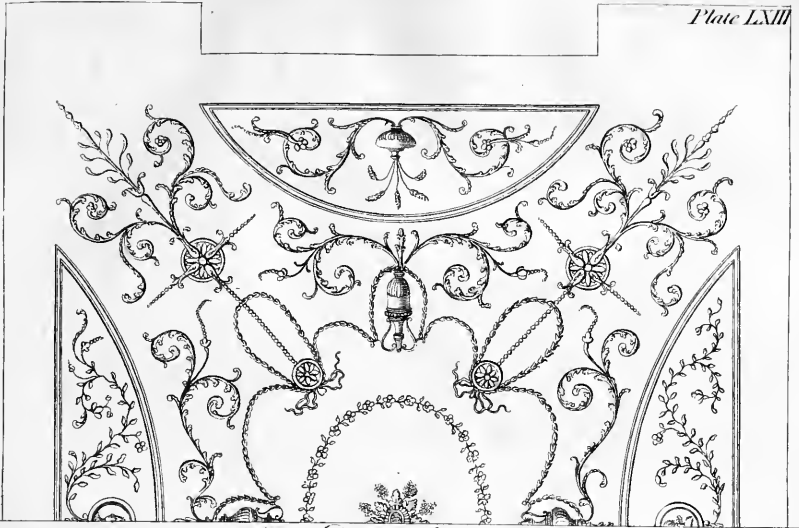

Two Designs for Ceilings.

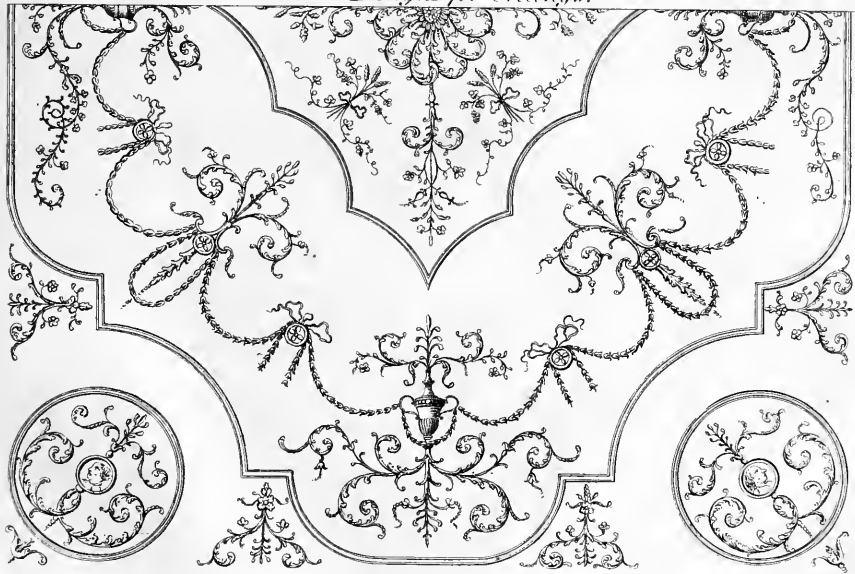

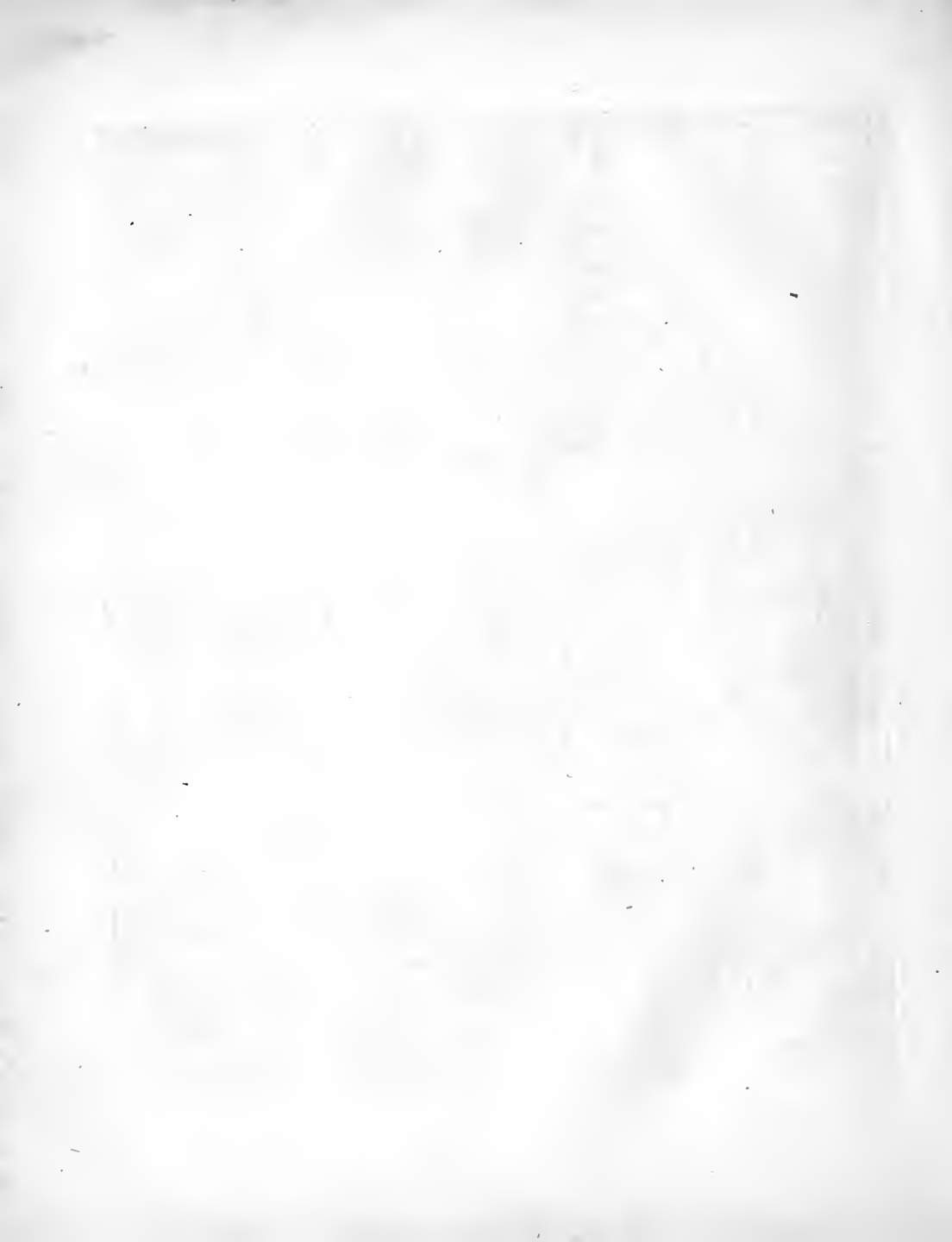

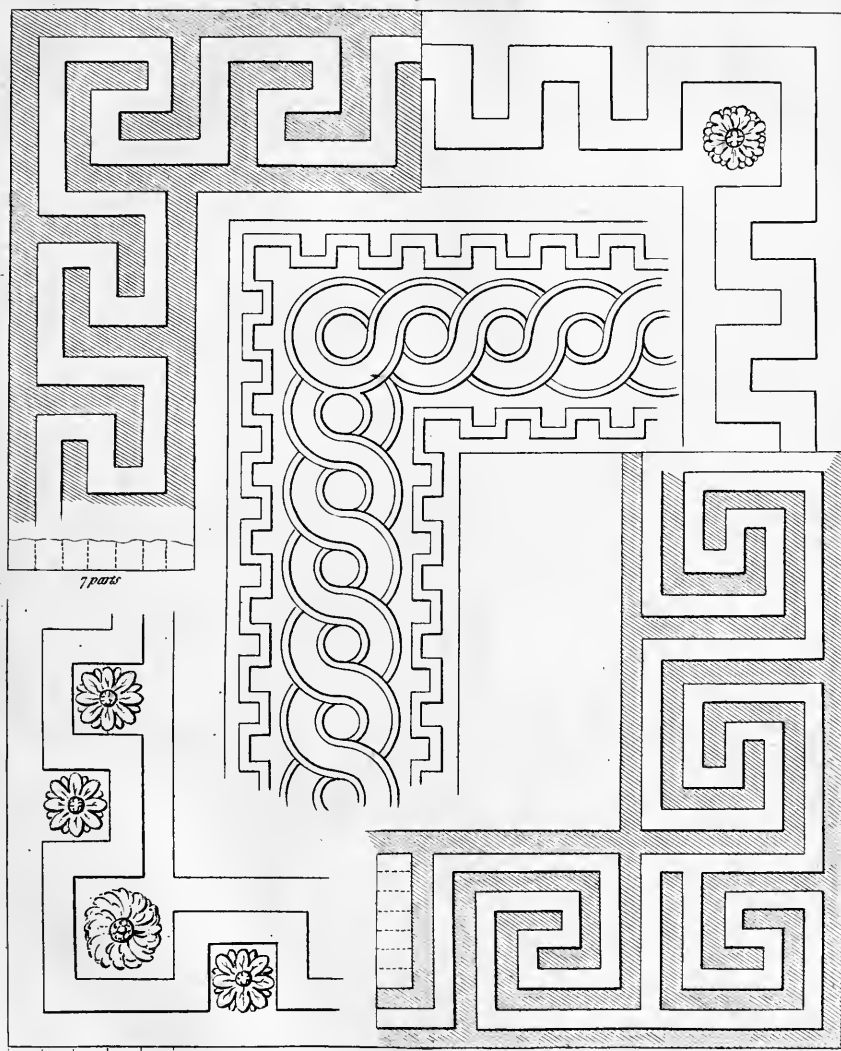

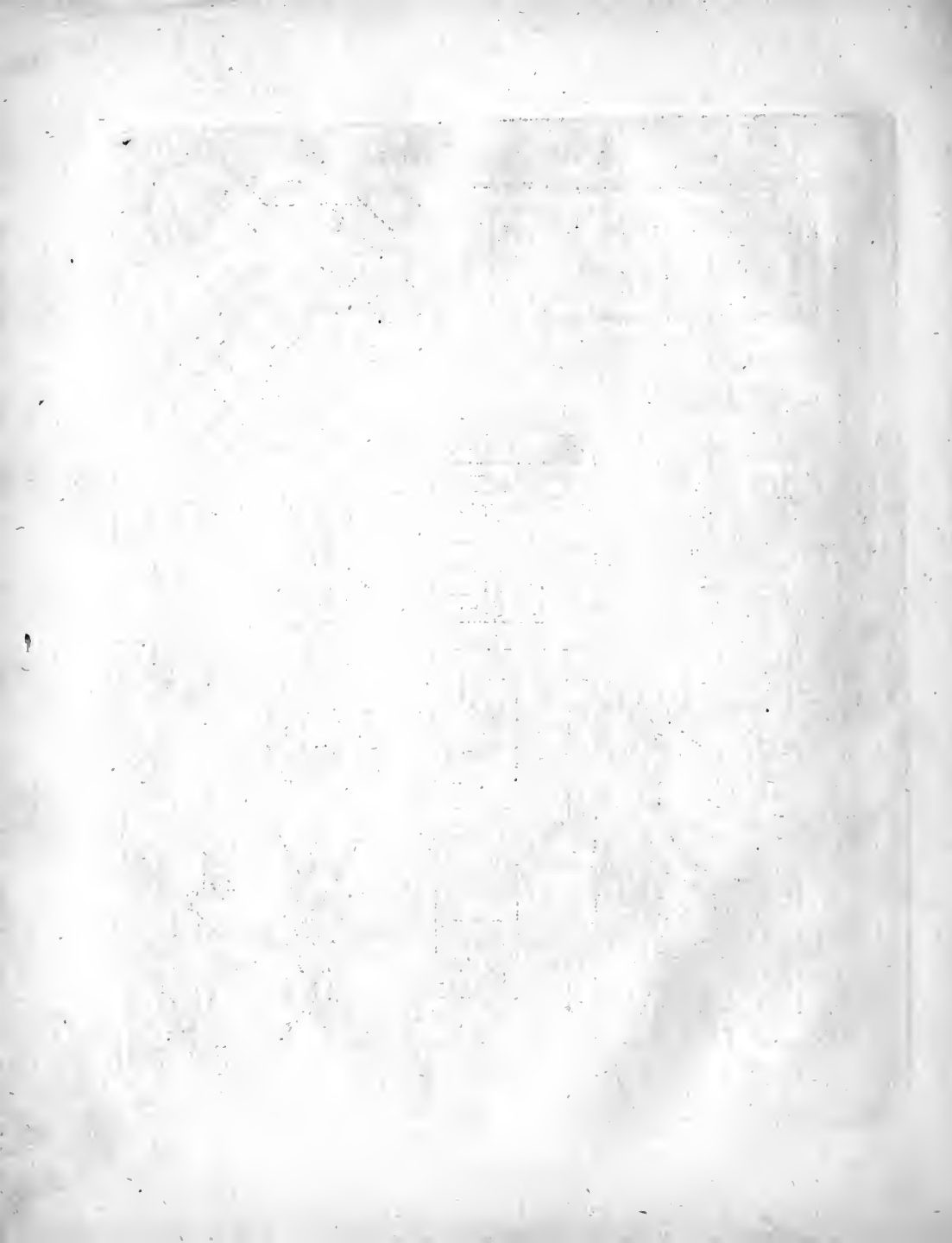

Frets.

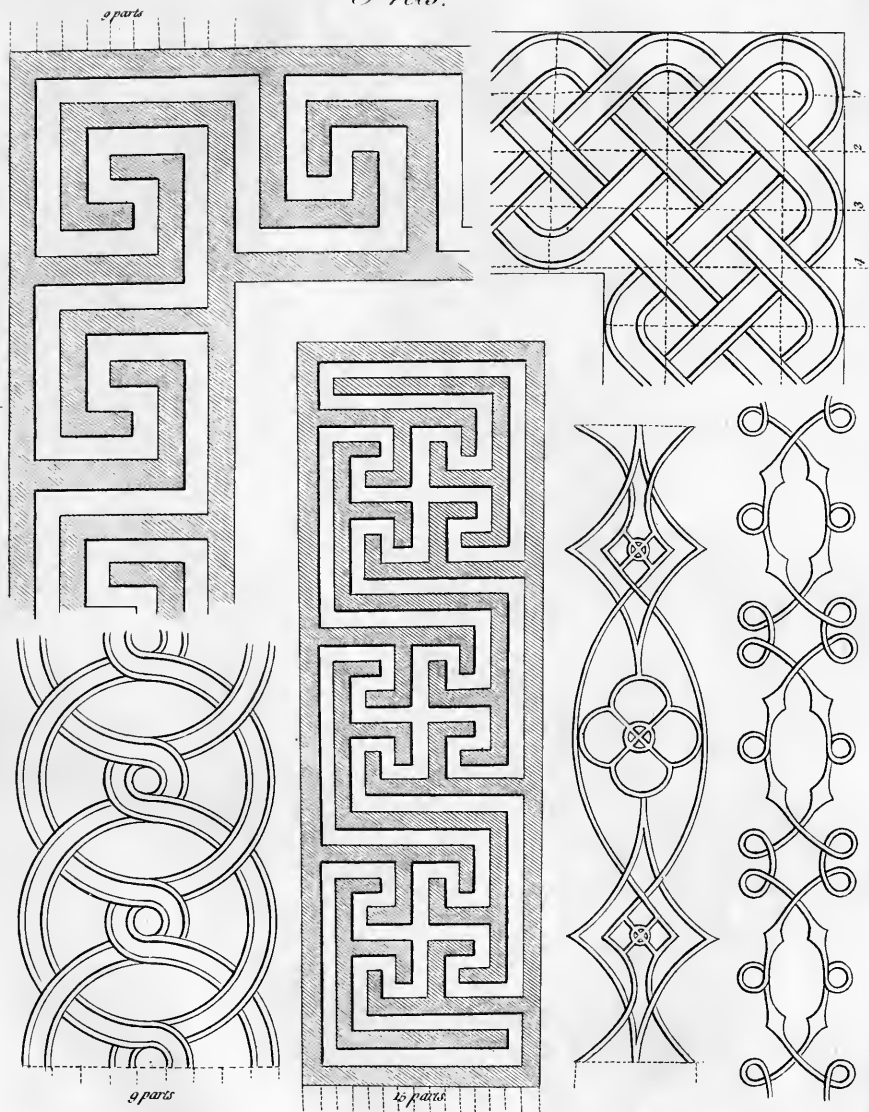



Vertical text columns in the upper right section, likely containing a title or header.

Vertical text columns in the center of the page, possibly representing the main body of text.

Vertical text columns in the lower right section, likely containing a signature or date.

Vertical text columns in the lower left section, possibly containing a preface or additional text.

*A Section of a Stair Case,
showing how the Steps & Carriage Timbers,
(Newels, &c. must agree with each other,
to make the Stairs Complete.)*

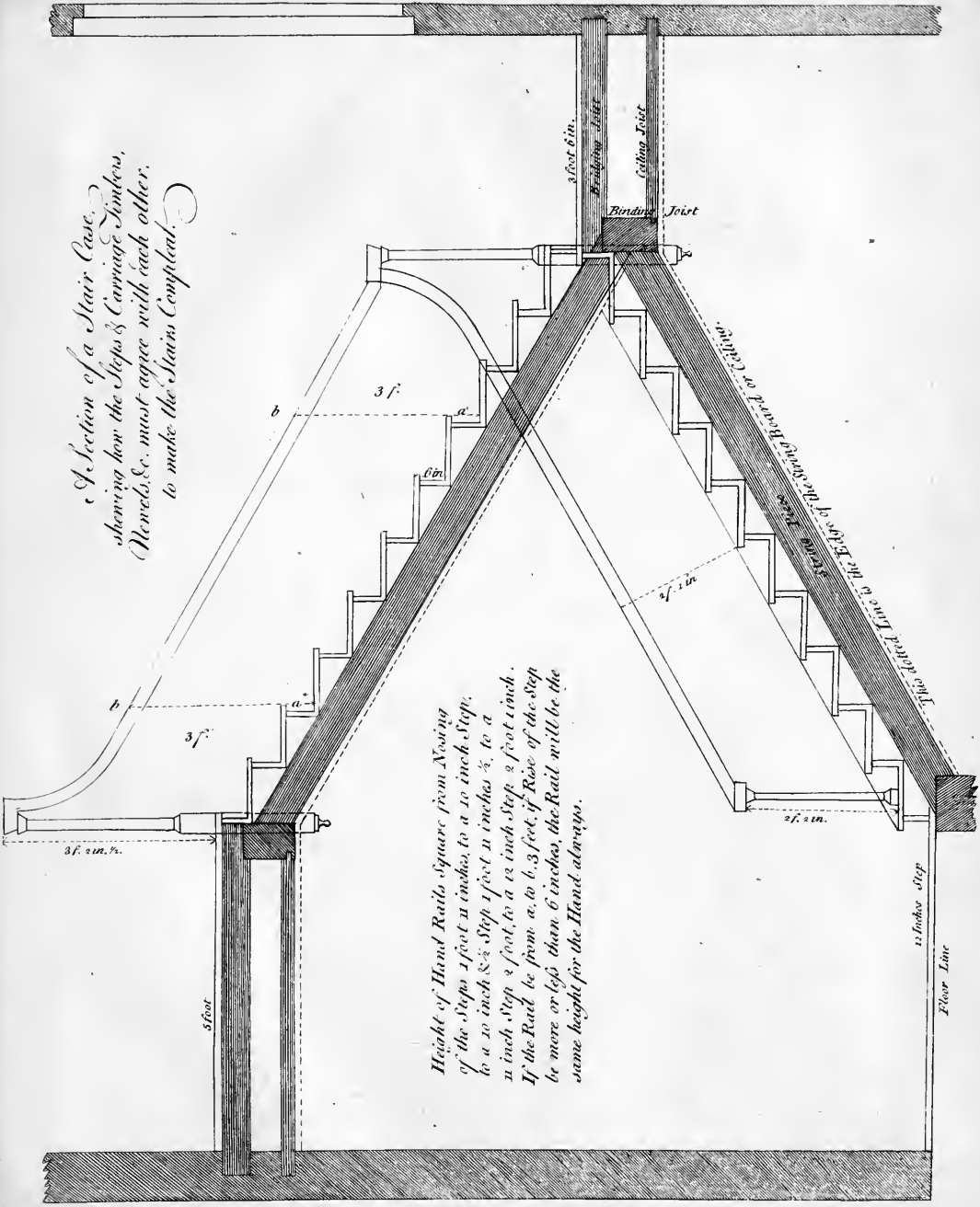

*Height of Hand Rail square from Nosing
of the Steps 1 foot 11 inches, to a 12 inch Step,
to a 10 inch $8\frac{1}{2}$ Step 1 foot 11 inches $\frac{1}{2}$, to a
11 inch Step 2 feet, to a 12 inch Step 2 feet 1 inch.
If the Rail be from a. to b. 3 feet, if Rise of the step
be more or less than 6 inches, the Rail will be the
same height for the Hand always.*

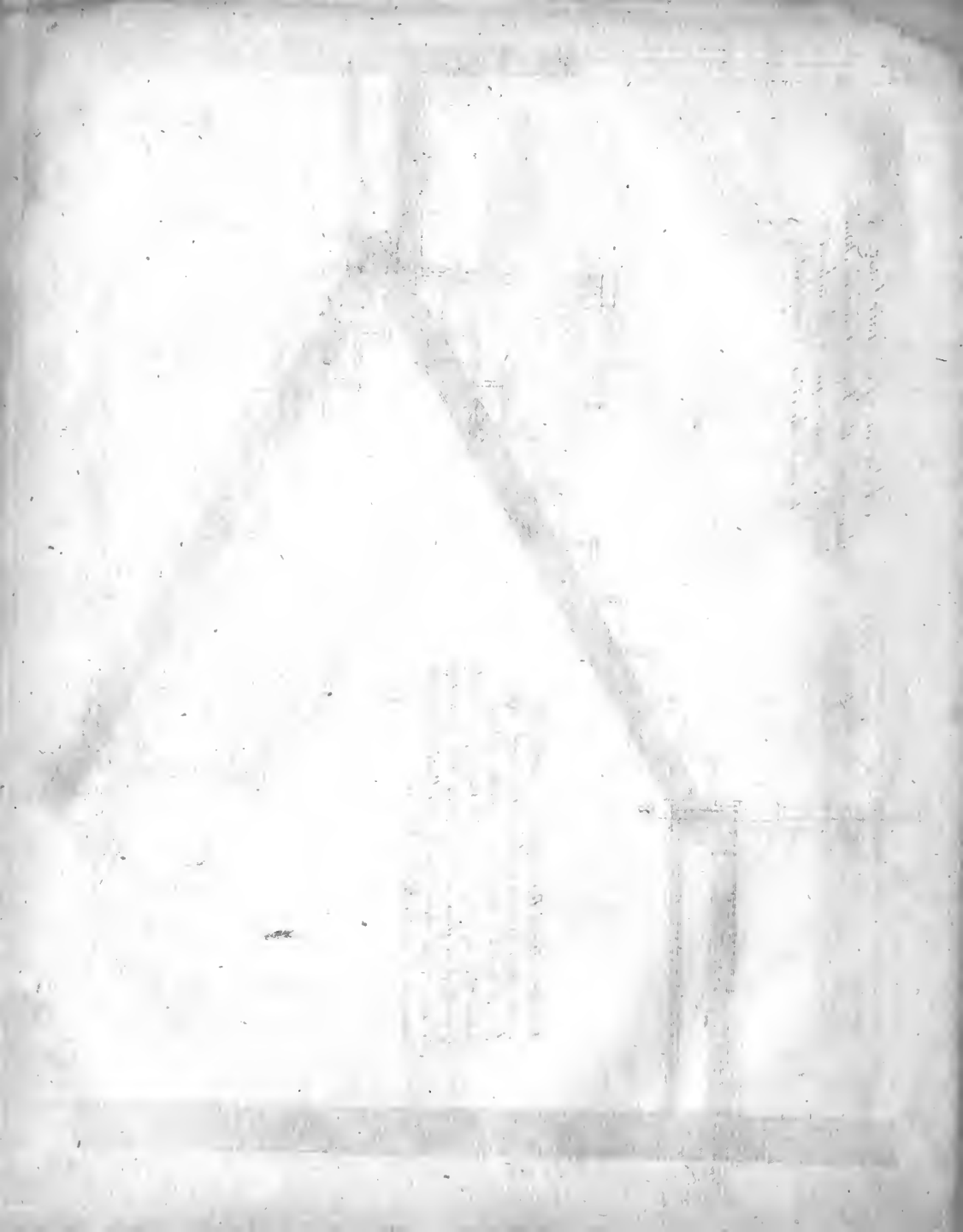

Elevation of a Bracket Stairs
in out Lines.

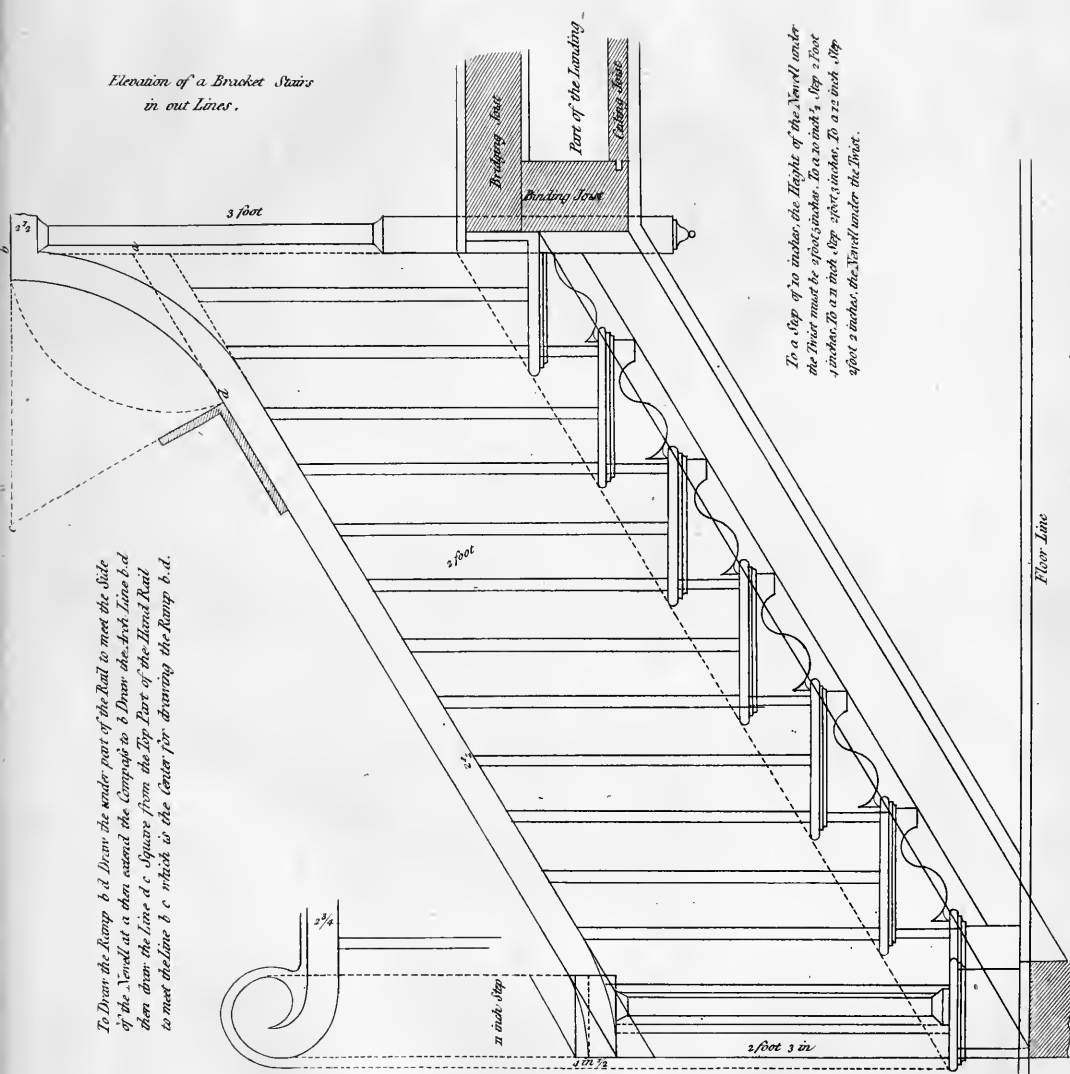

To Draw the Ramp b d Draw the under part of the Rail to meet the Side of the Veneel at a then extend the Compas to b Draw the Arch Line b d then draw the Line d c Square from the Top Part of the Hand Rail to meet the Line b c which is the Center for drawing the Ramp b d.

To a Step of 20 inches, the Height of the Veneel under the Rail must be 2 foot, 6 inches. To a 20 inch $\frac{1}{2}$ Step 2 foot 4 inches. To a 21 inch Step 2 foot 3 inches. To a 22 inch Step 2 foot 2 inches. the Veneel under the Rail.

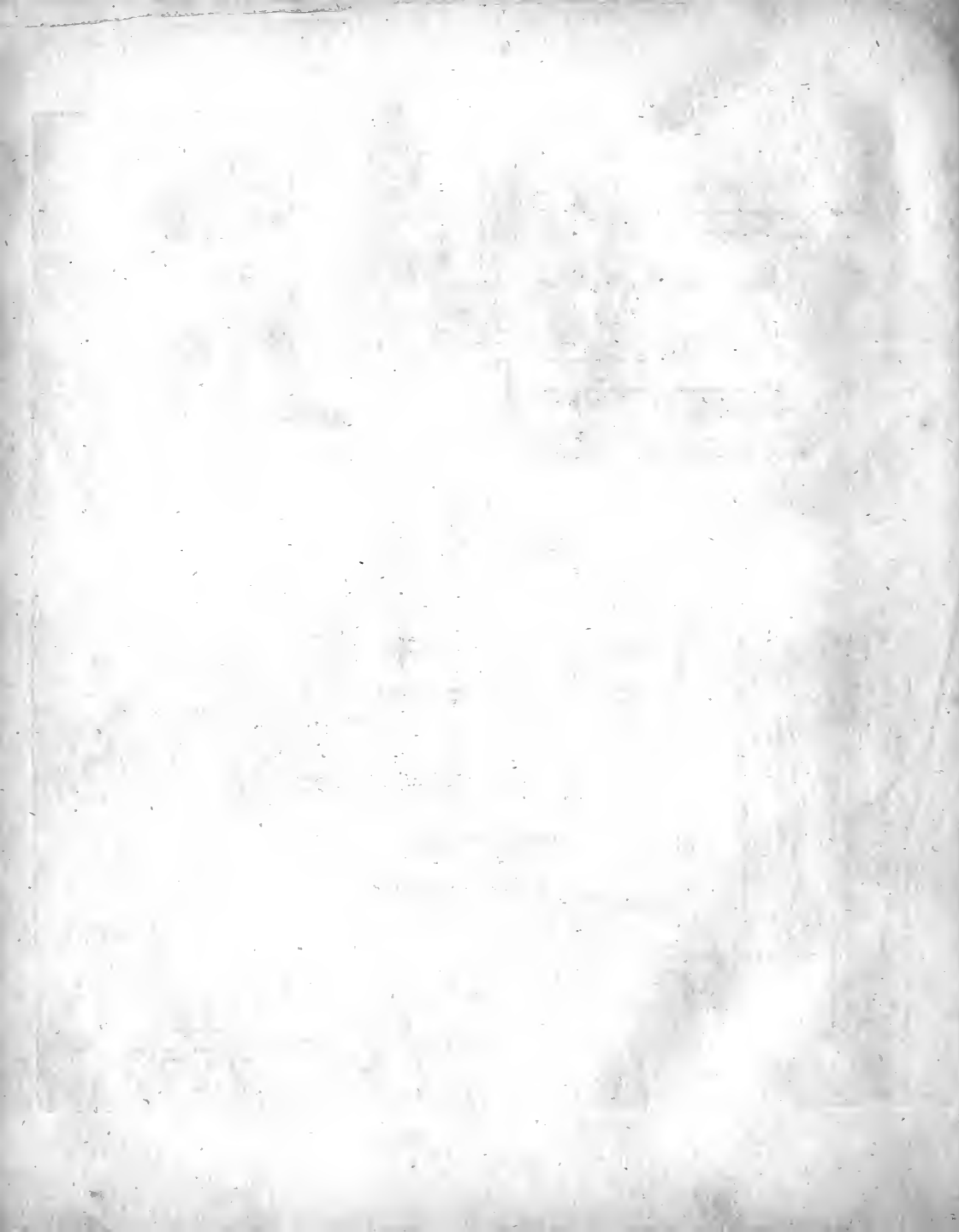

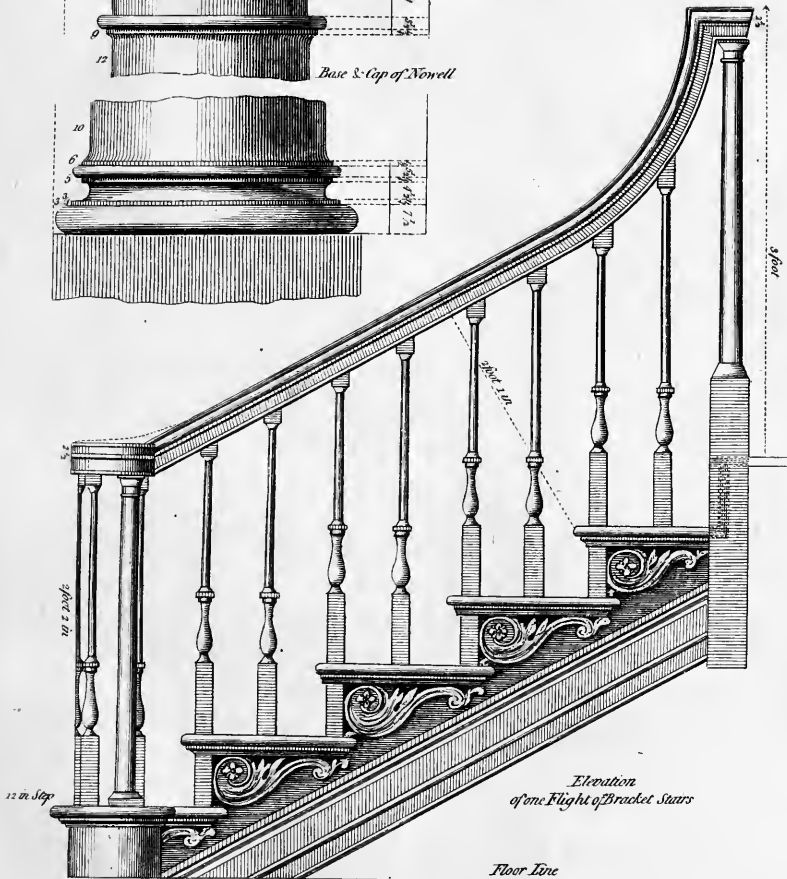
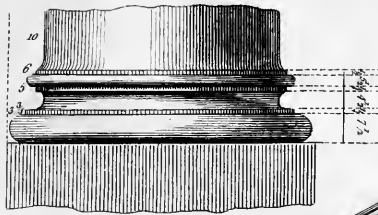
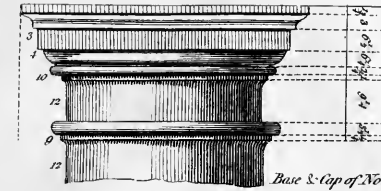



THE P. A. T. LINE

... ..

... ..

... ..

... ..

To face P L A T E LXIX.

To draw the Plan and Scroll of a twist Rail for a Stair-Cafe.

DRAW a Circle equal to the Breadth of two Steps, and divide it into eight Parts, then draw a Circle round the Centre five Inches Diameter, as 2, 3, then draw the Line *e, f*, and set one Foot of the Compass at *e*, and draw the Arch Line 7, 0, which must be divided into eight Parts, and draw Lines from *e*, thro' each eighth Part to the Line 1, 2, 3, 4, 5, &c. then set the Compass in the Centre of the Scroll, and draw the dotted Lines from 1 on the Scale to 1 on the Edge of the Rail, and from 2 to 2 on the Edge of the Rail, and so for all the Rest to each eighth Part of the Circle, which gives the outer Edge of the Rail.

To find the Centre for drawing each eighth Part, set one Foot of the Compass in the Centre of the Scroll, and take the Distance to *f*, with the same Radius; set the Foot at *e*, and make a Mark at *c*, and with the same Radius set one Foot at 1 on the Edge of the Rail, and bisect the former Stroke at *c*, which is the Centre for the first eighth Part, then take from the Centre of the Scroll to 1 on the Scale, and set one Foot at 1 on the Edge of the Rail, make a Mark in the Eye and move the Compass to 2 on the Edge of the Rail, and bisect the former Stroke, that is the Centre for the second eighth Part, and so on for all the Rest. The Centre for the Front of Riser and Nosing of Step are the black Dots, one fifth Part from the Rail to the Nosing of the Step without the other Centre; the Pieces which make the twist Part of the Rail are *d, e, b*, on the raking Mould the Twist begins at *a* on the Edge of the Rail, and Ends at three on ditto, the remaining Part is level; the lower Part of the Scroll from 2 is cut out of a Parallel Piece, as represented by *g* on the Newel, &c.

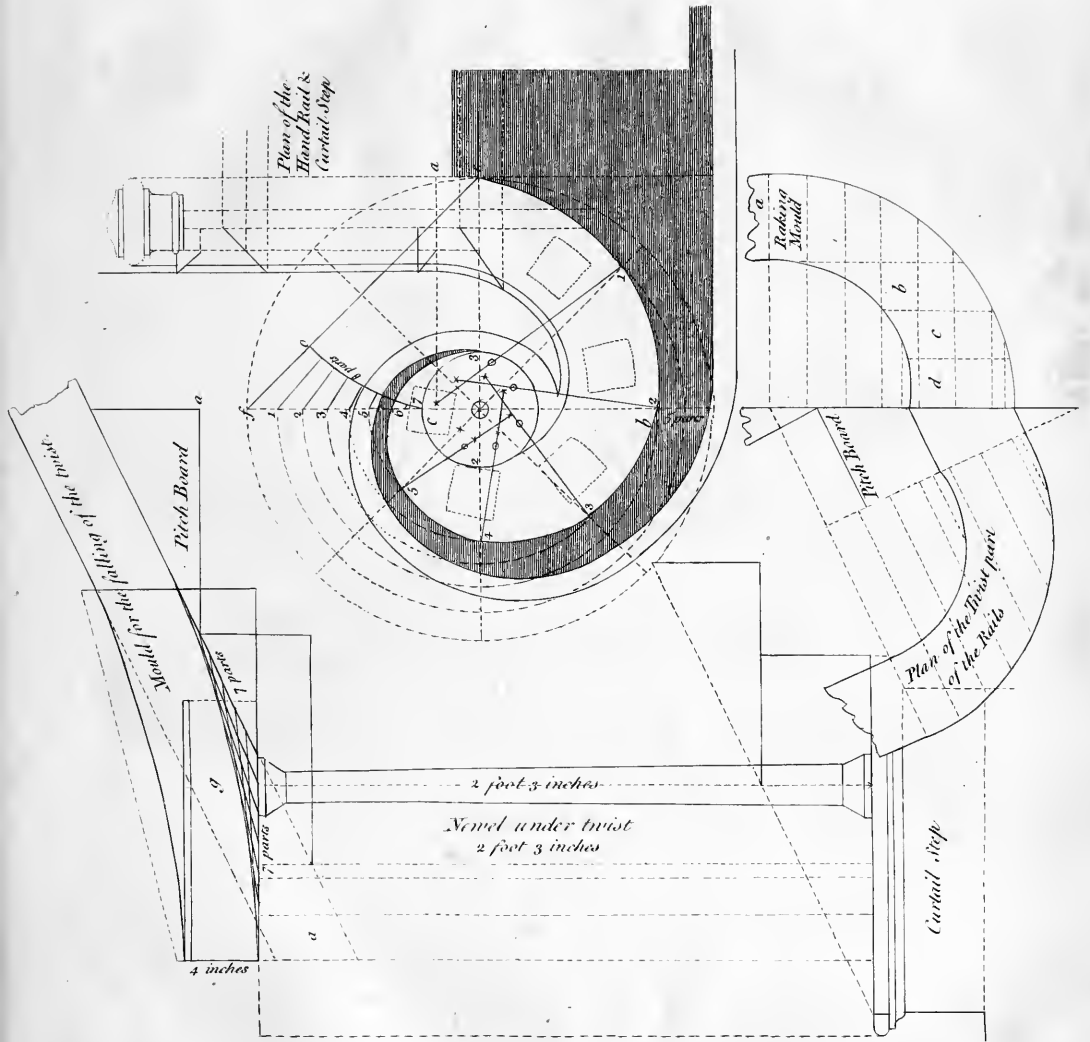

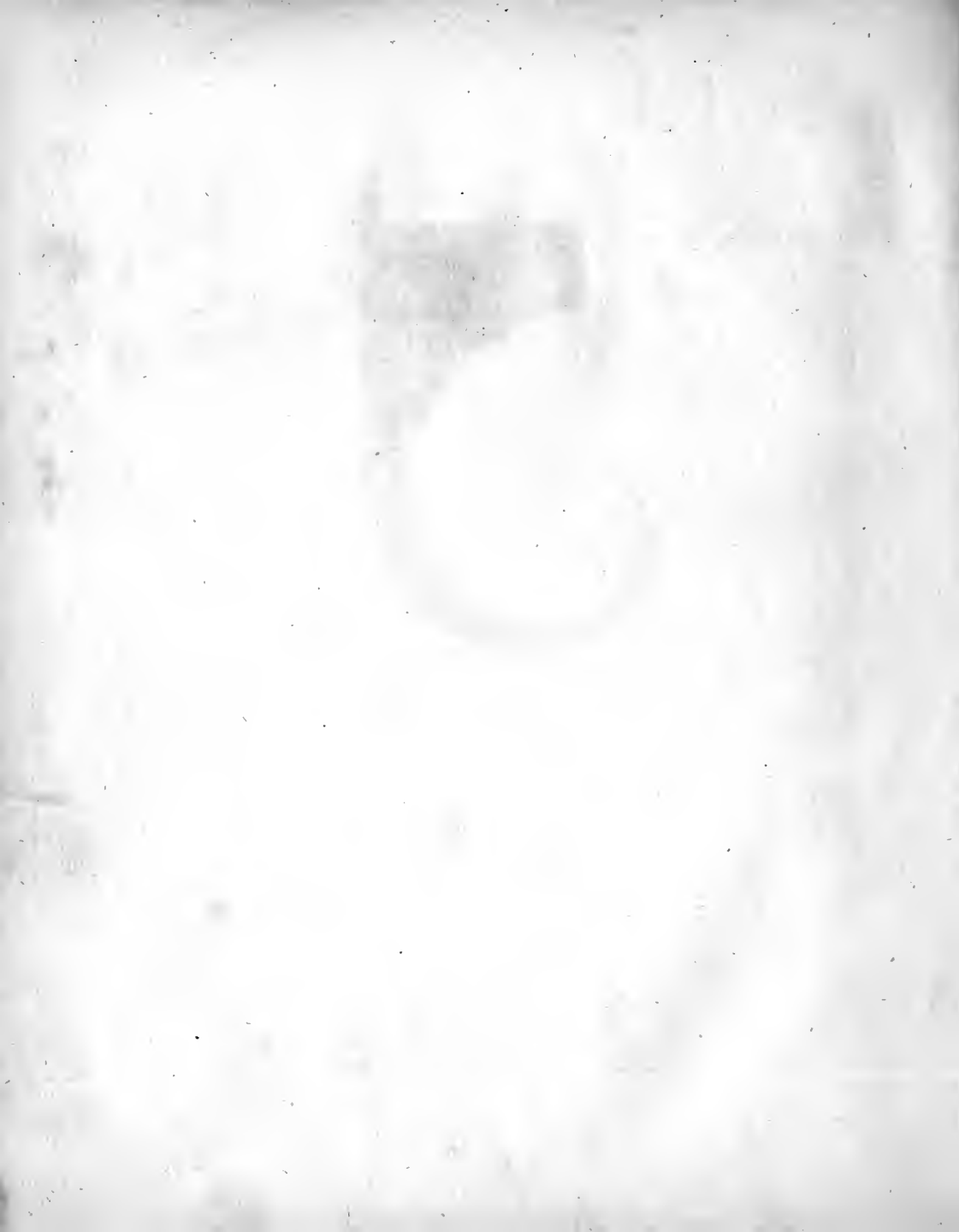

n Inches

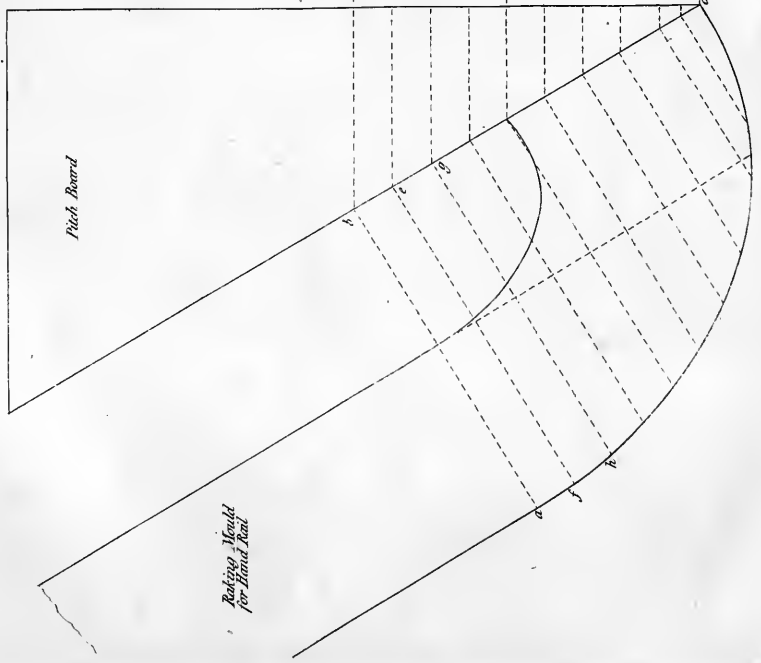
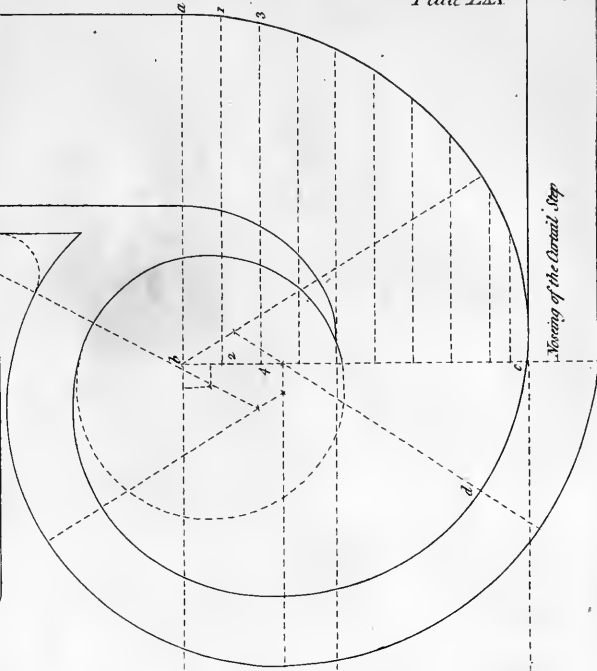
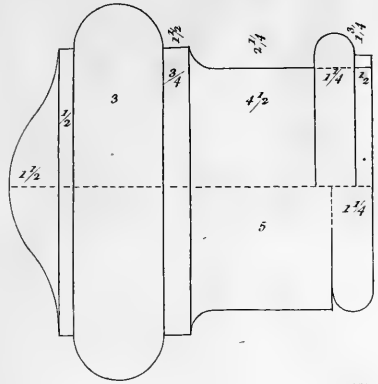
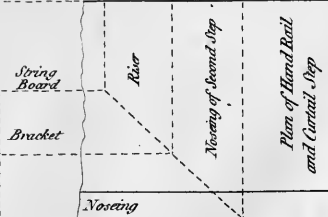



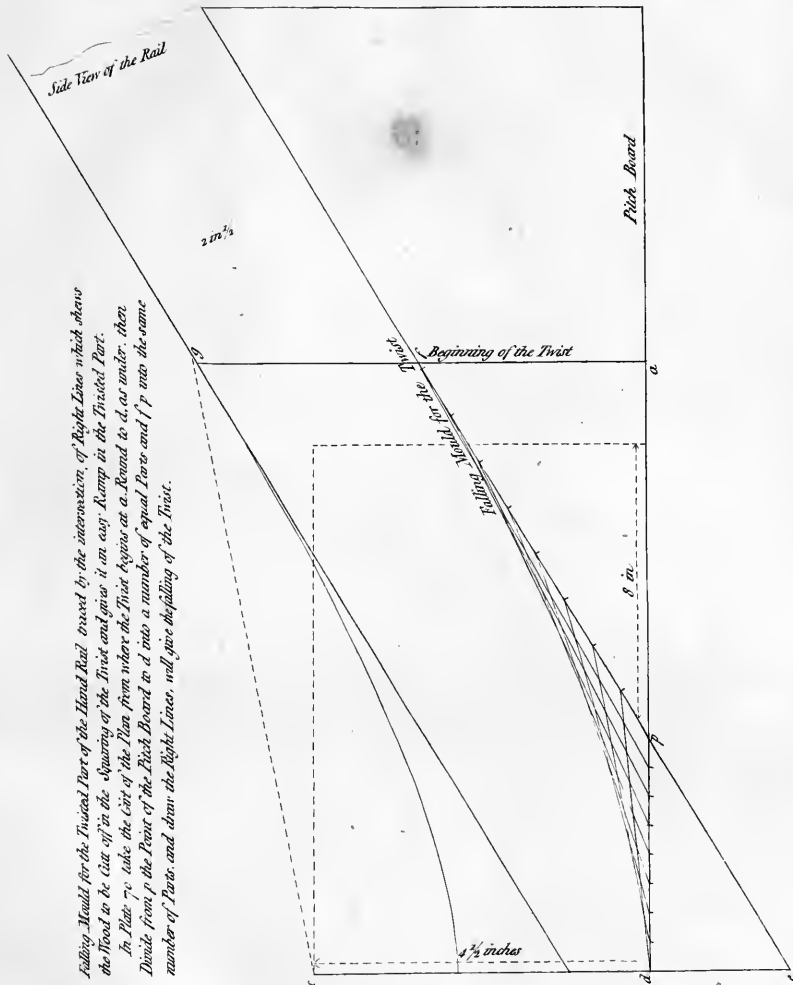

Fallings should for the twisted part of the Hand Rail be cut by the intersection of Right Lines which show the Wood to be cut off in the squaring of the Twist and give it an easy Ramp in the twisted Part.
 In Plan, take the left of the Plan from where the Twist begins at a. Round to d. as under, then Divide from p the Front of the Truck Board to d into a number of equal Parts and p over the same number of Parts and draw the Right Lines, will give the falling of the Twist.

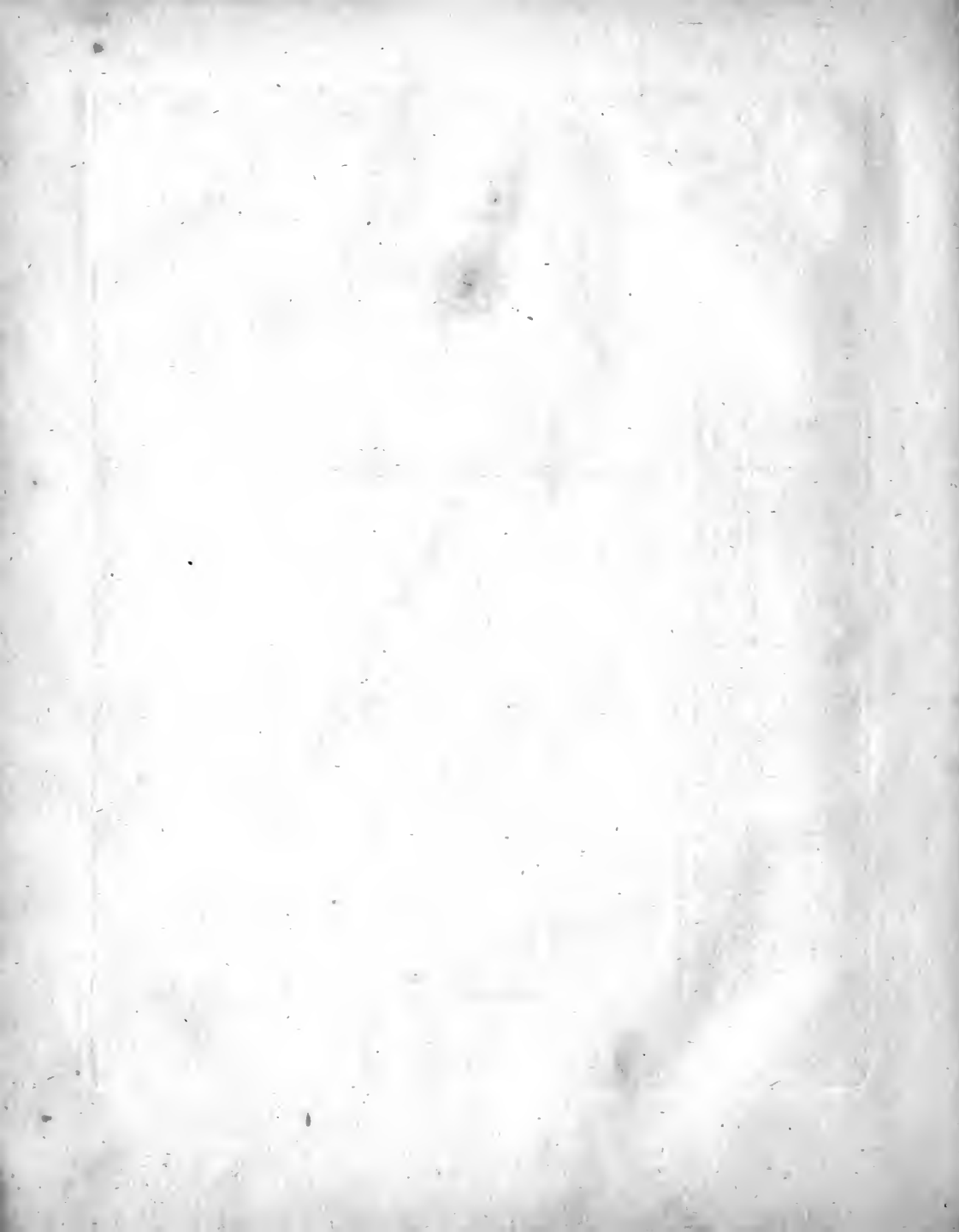

The Twist Rail with its
 Moulds exactly figured.

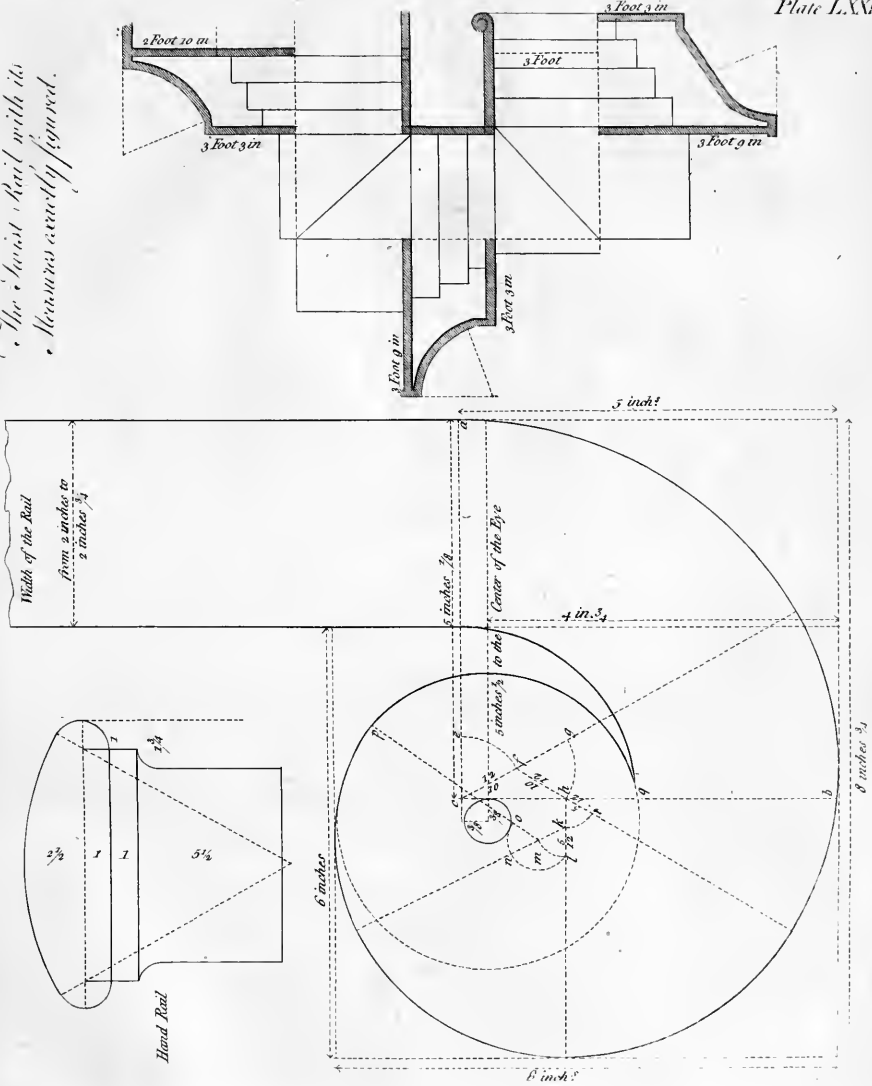



Two Plans for Stair Cases.

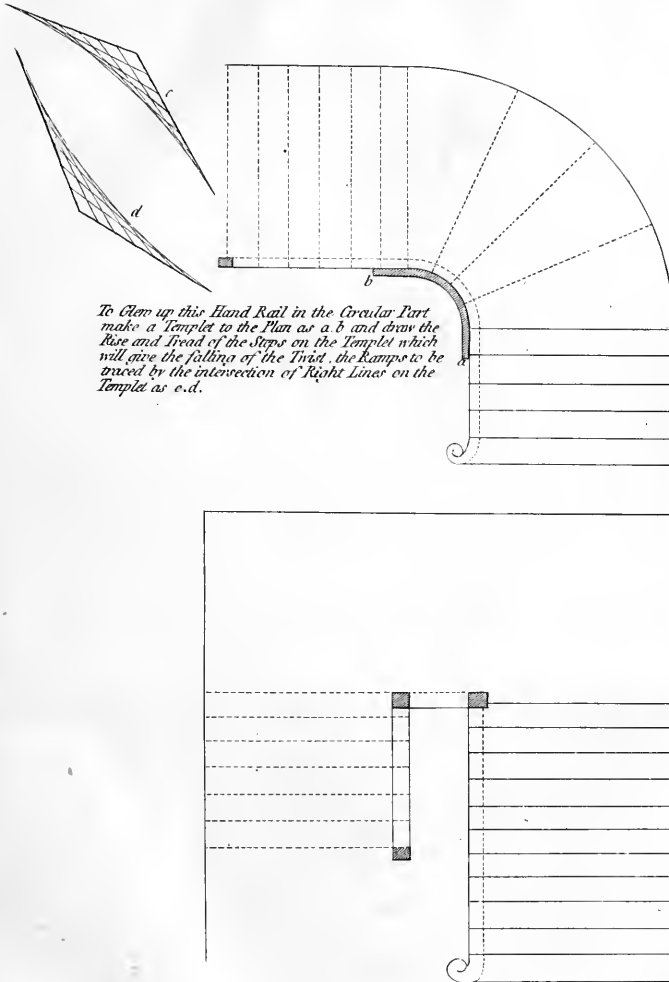

To Clear up this Hand Rail in the Circular Part make a Templet to the Plan as a b and draw the Rise and Tread of the Steps on the Templet which will give the falling of the Tread, the Ramps to be traced by the intersection of Right Lines on the Templet as e.d.



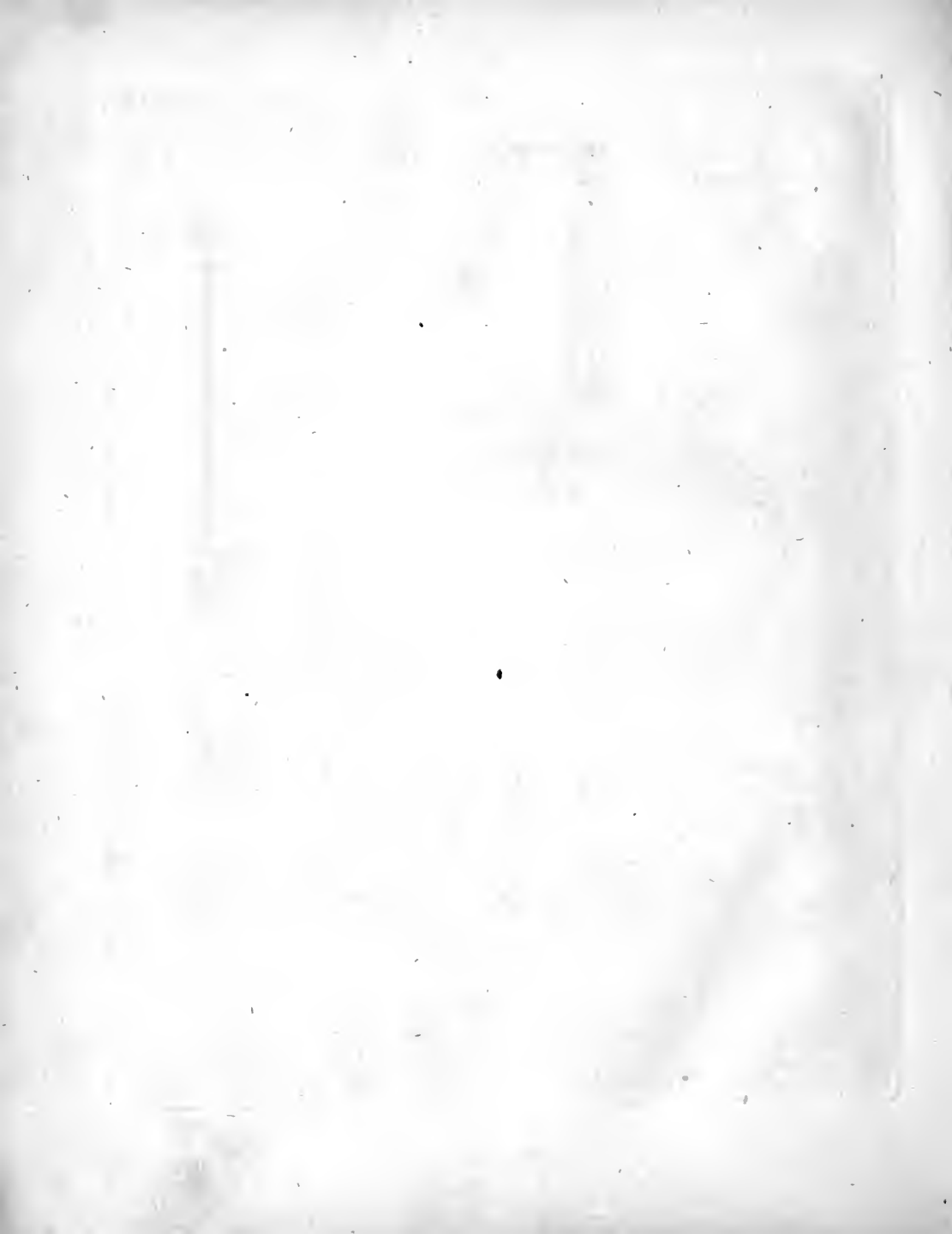

Plan & Elevation of a Circular & Oval Stair Case. Plate LXXV.

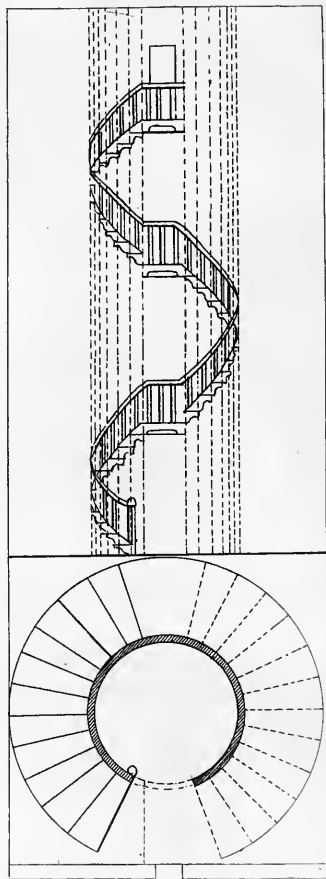
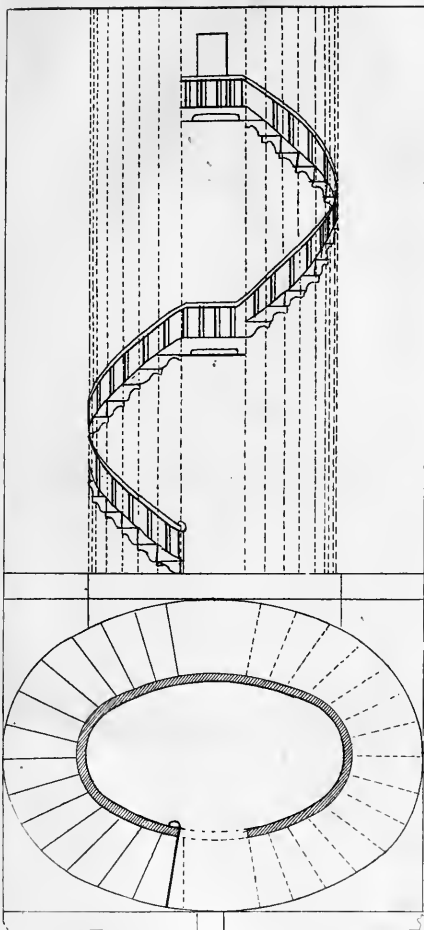

To be lighted by a Dome or Cone Lanthorn at the top, if placed in the middle of a Building. If on the outside may be lighted by Windows in the Wall at each landing.
To make the Hand-rail make a Temple or Cylinder to the well hole or open of the Rail, draw the tread & rise of each Step on the Cylinder, and that will give the falling of the Rail which is to be glewed in thickness bent round the Cylinder, then the Rail will come off ready squared, this is a very sure way to make the Rail.

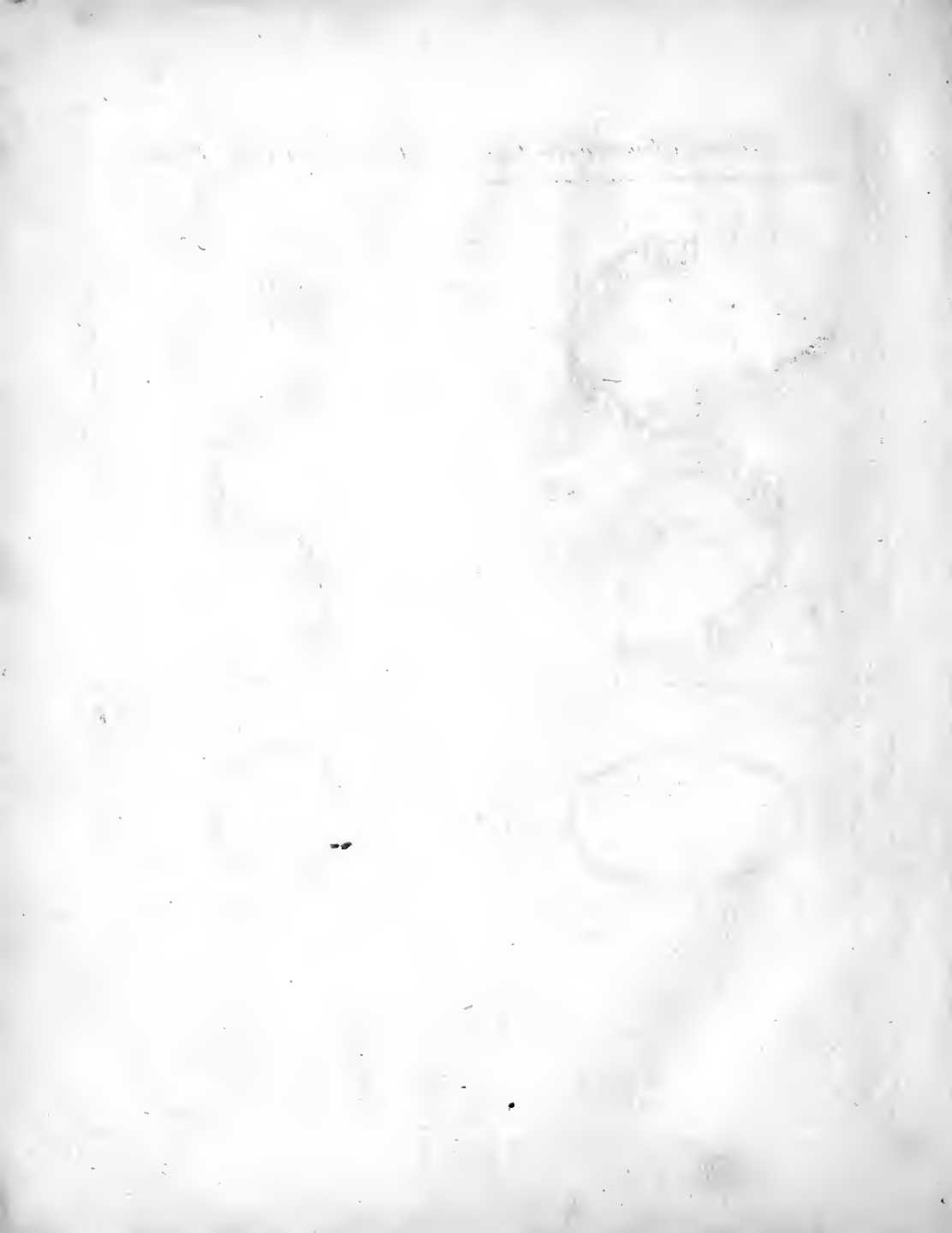

Plan, Elevation & Section of a Gentlemen's House, the Offices being in the Basement Story.

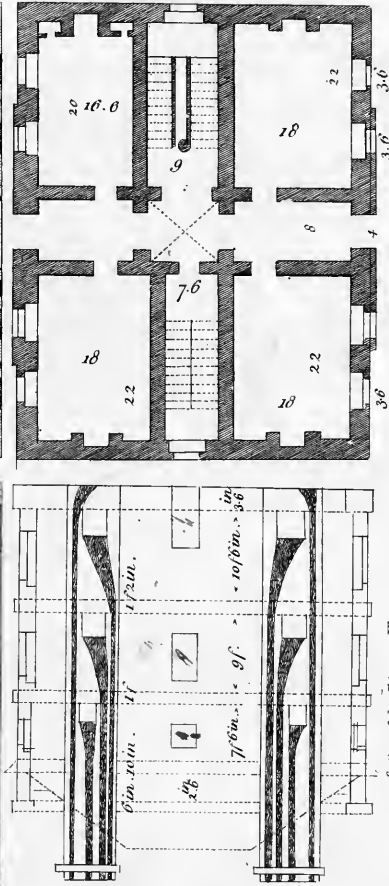
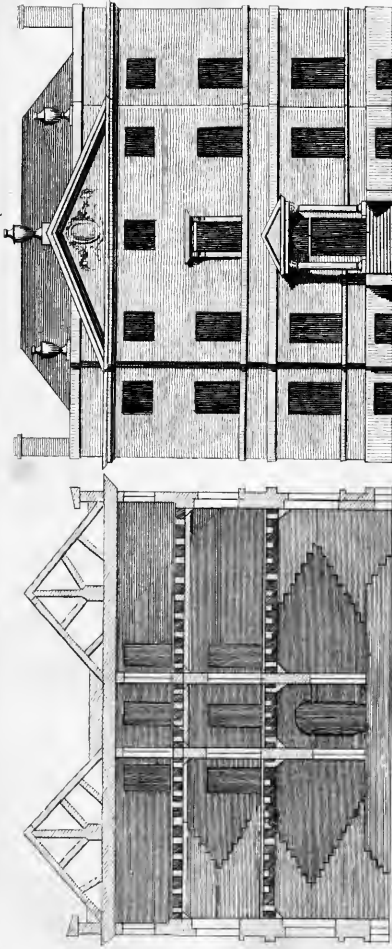

Section of the Chimney Flues.

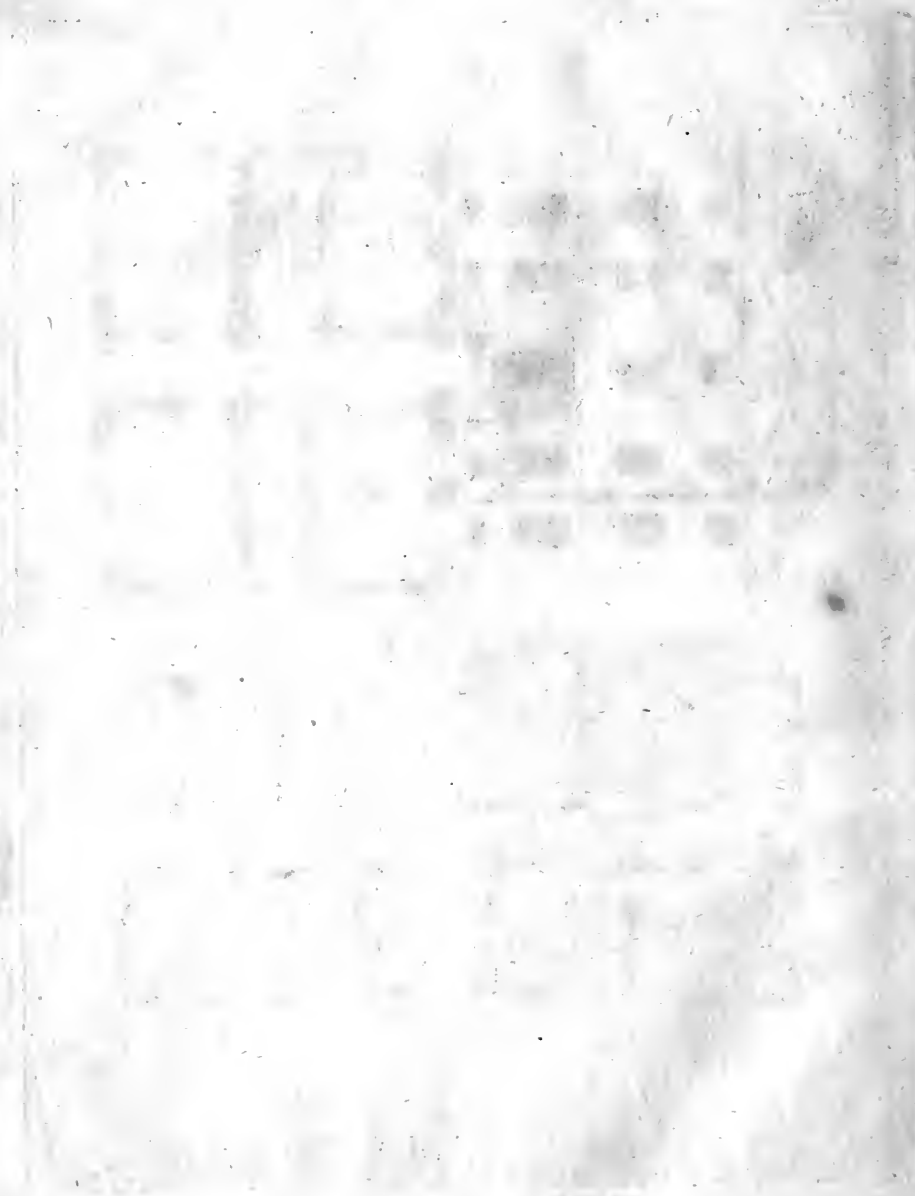

Plan and Elevation of a Gentleman's House.

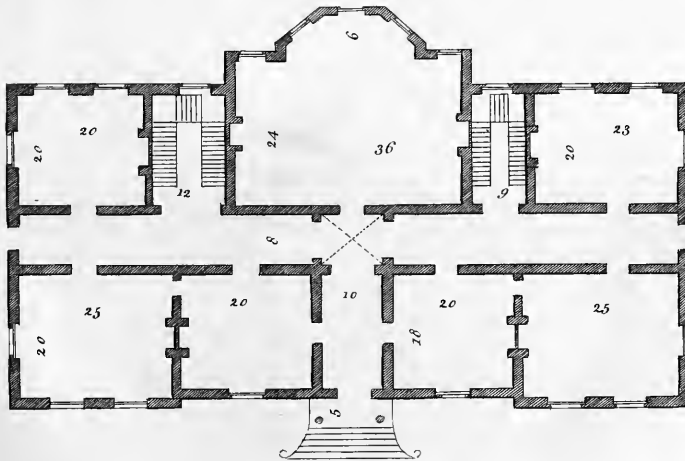
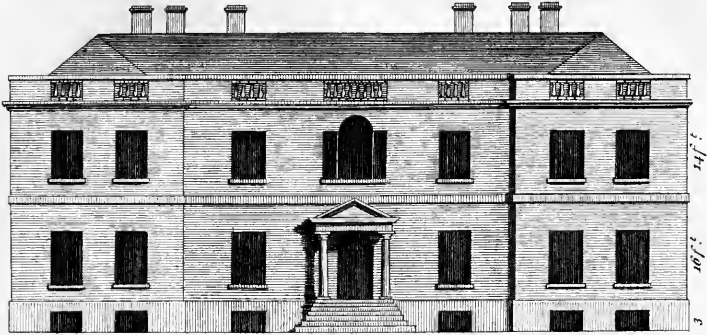

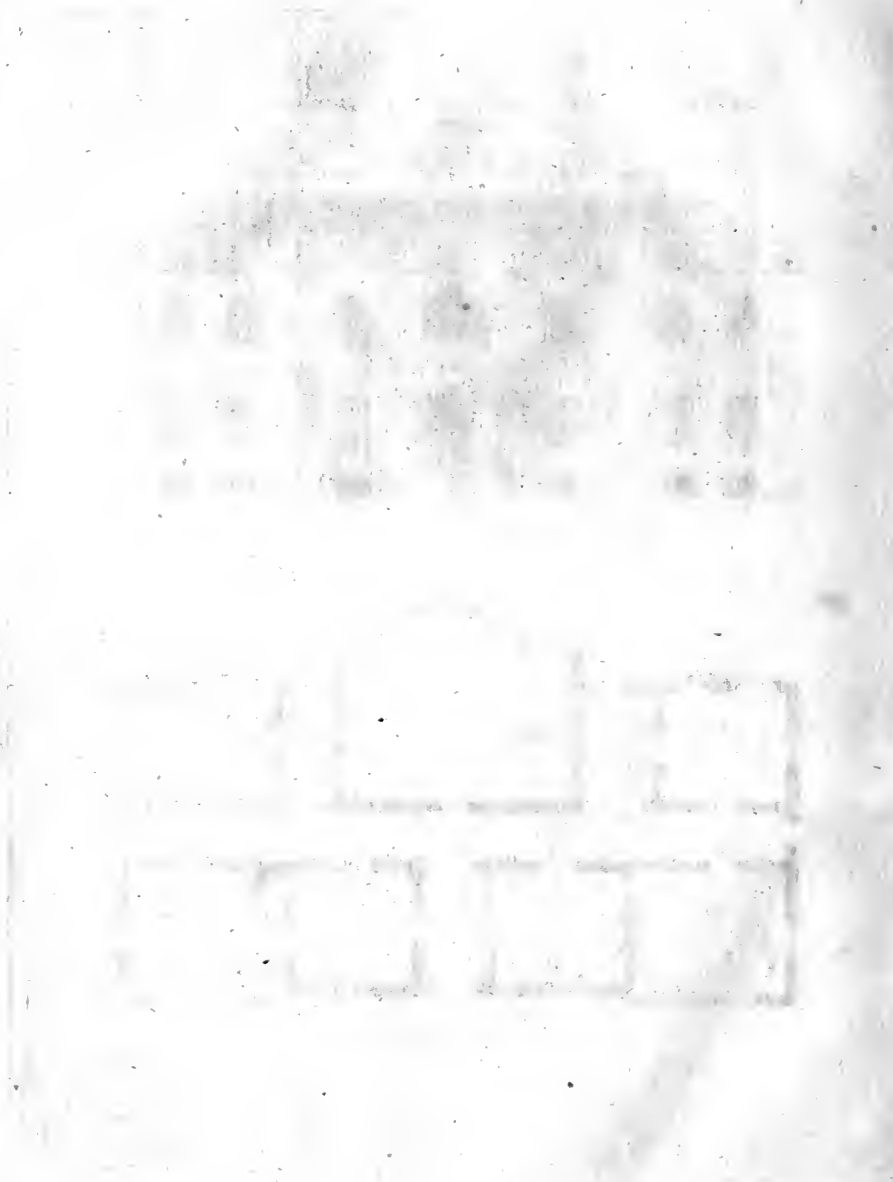

Plan & Elevation of a Gentlemans House.

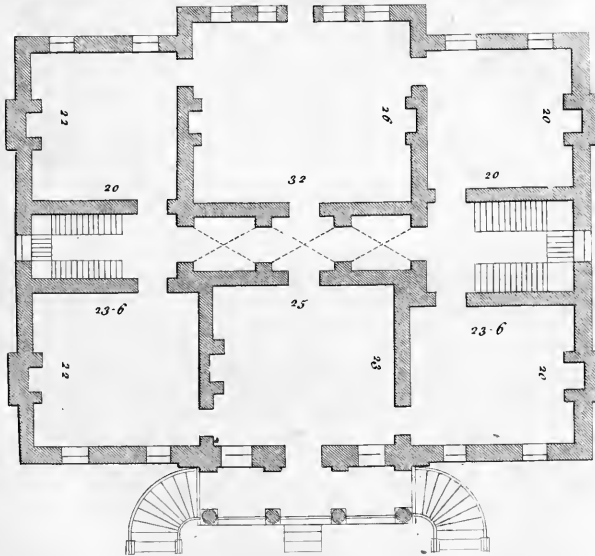
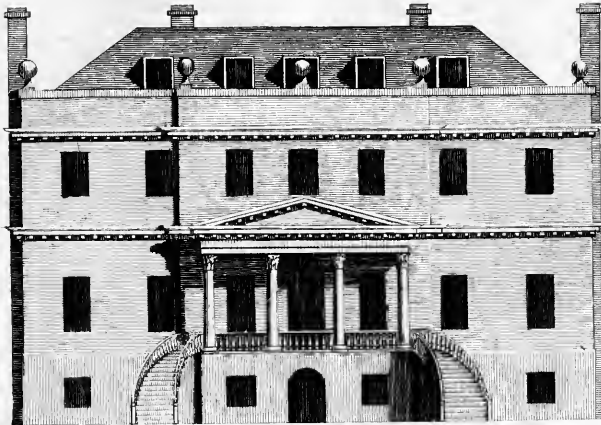



Plan & Elevation of a House for a large Family.

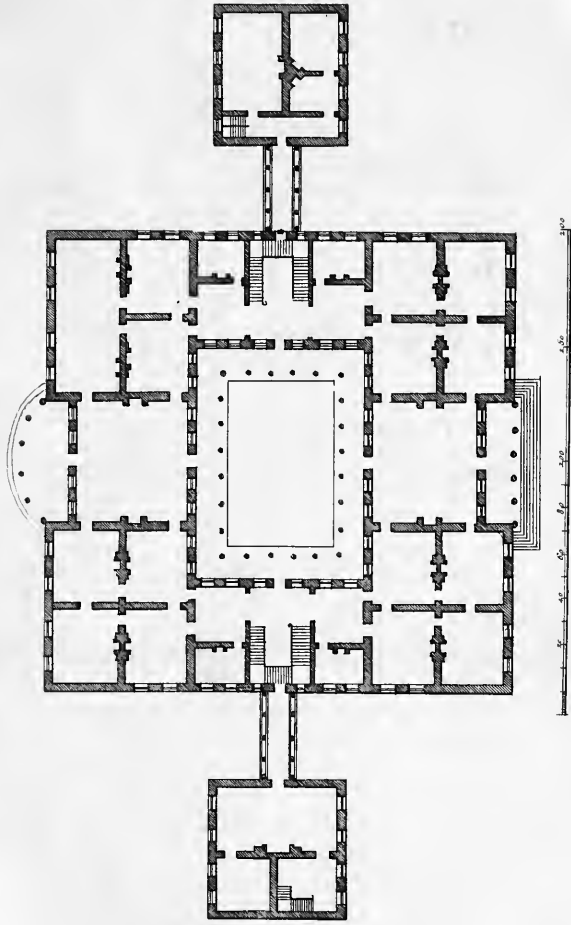
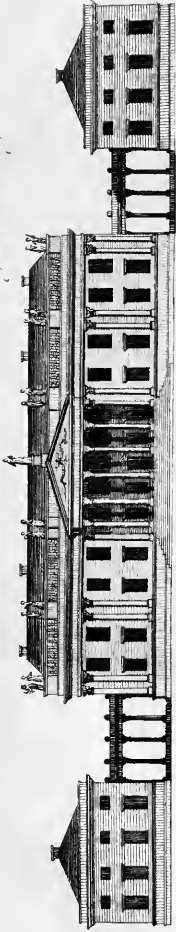

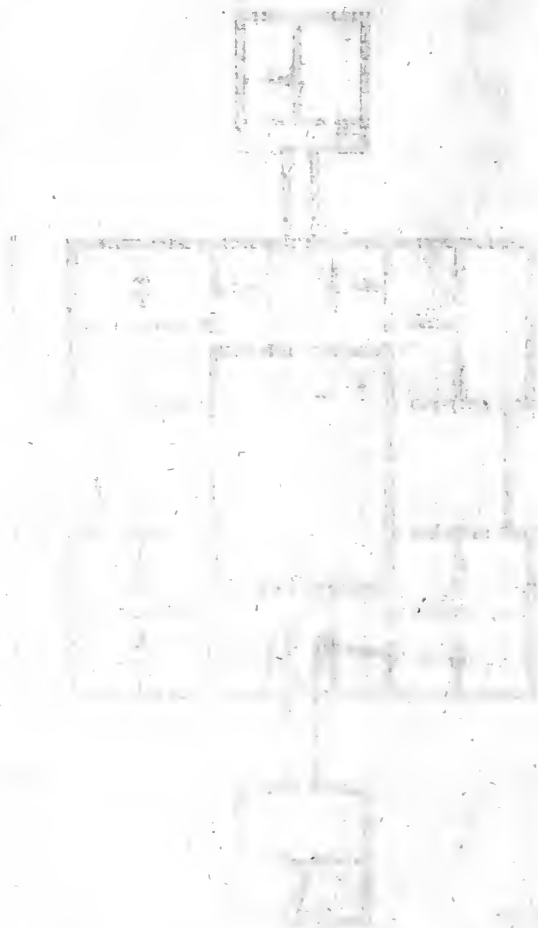

Plan and Elevation for
a Dwelling-House.

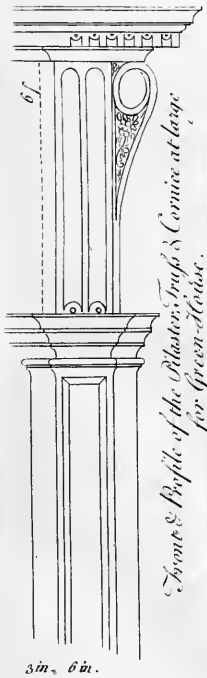
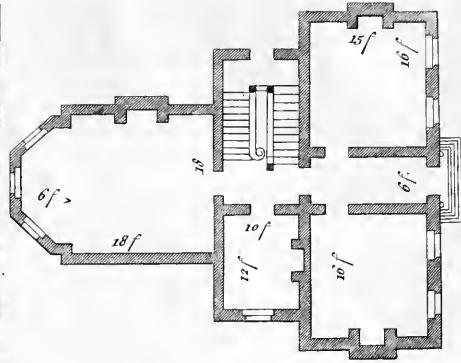
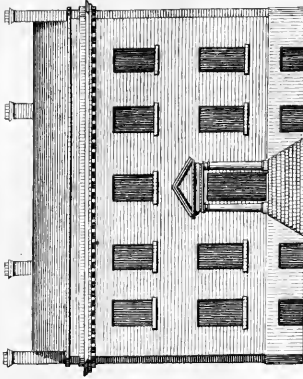

Front & Profile of the Plaster, Truss & Cornice at large
for Green-House.

3 in. 6 in.

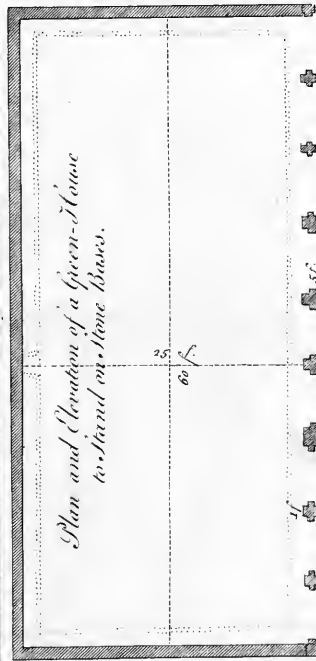
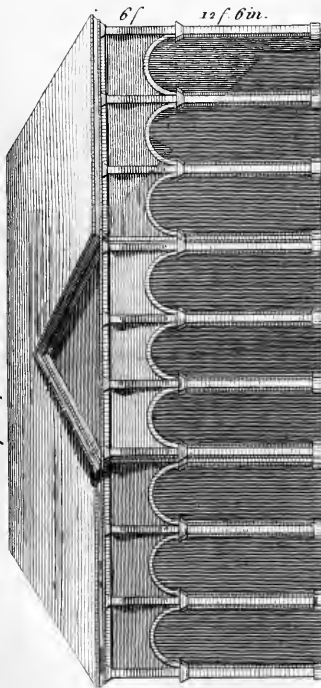

Plan and Elevation of a Green-House
to stand on Stone Walls.

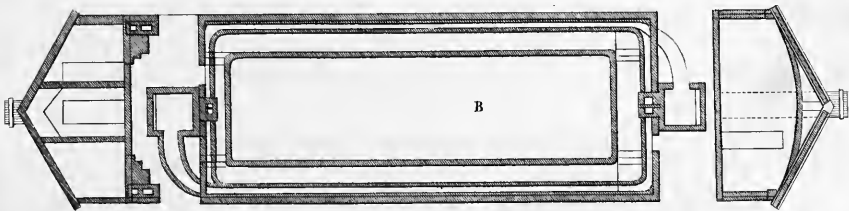
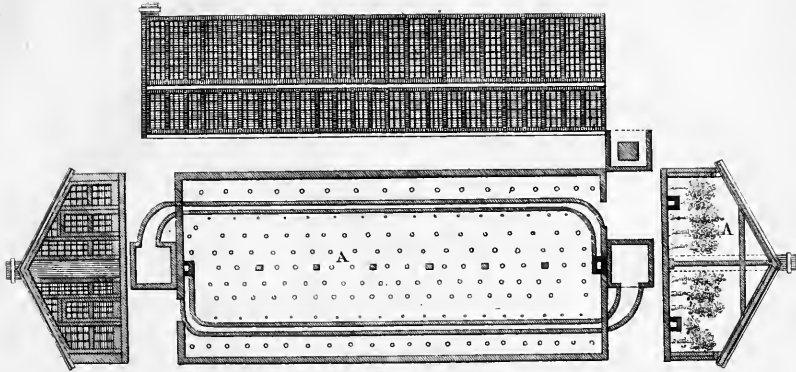

*Two Plans, Elevations and Sections for Stoves or Hot Houses
for Pines, Fruit Trees, Strawberries &c.*

The Plan and Section A is for Fruit Trees.

The Plan B, for Pines; the Plans in this Plan run one over another as may be seen in the Section, There are Fire Places at each End and a Walk all round.

The Plans in the Plan A. Run on the Surface and are single Plans.

The Front Roof and Ends Glass, as the Elevation of the Plan A.

The Width of each House is 16 Feet the Length at Pleasure from 40 to 50 Feet. or more at pleasure.

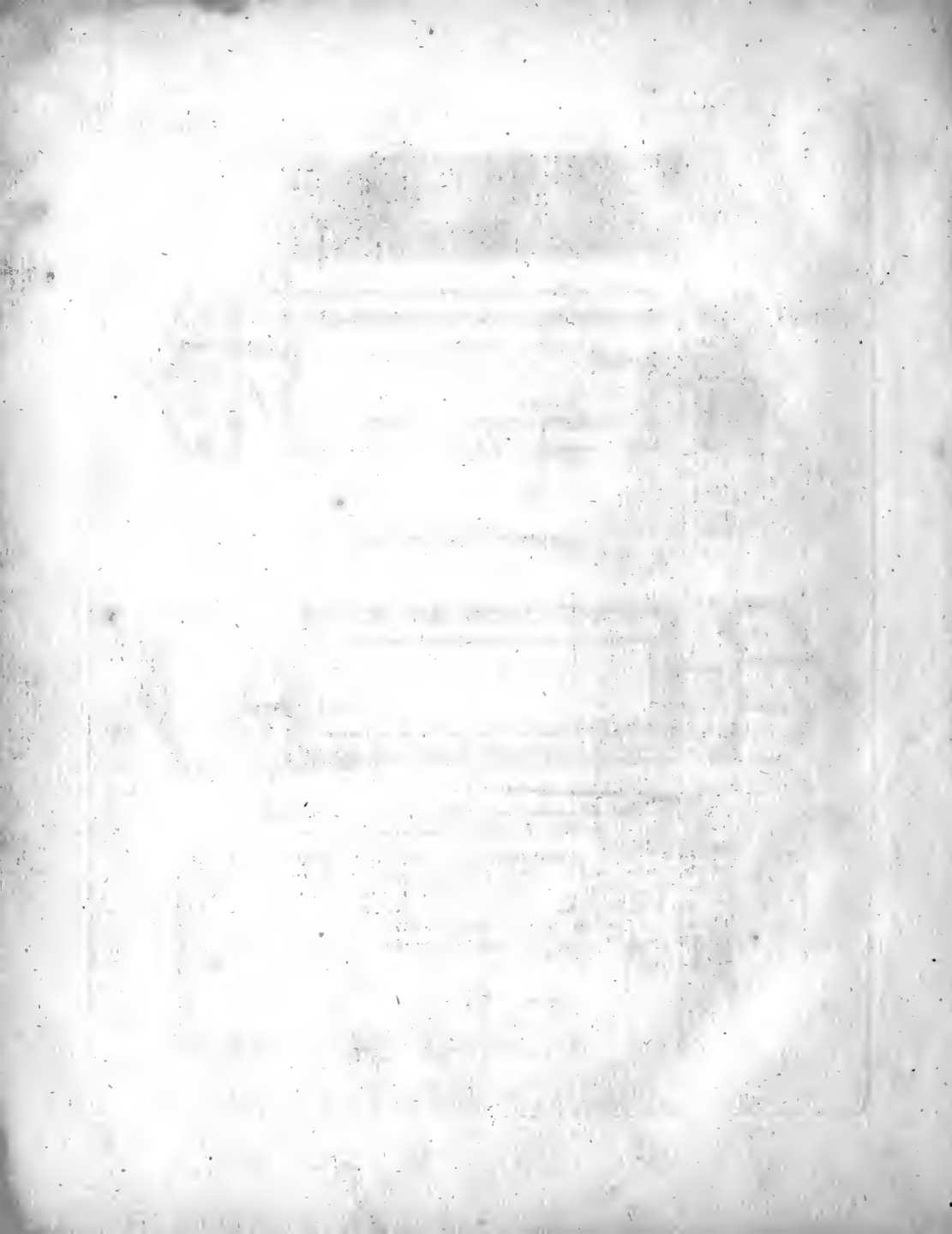

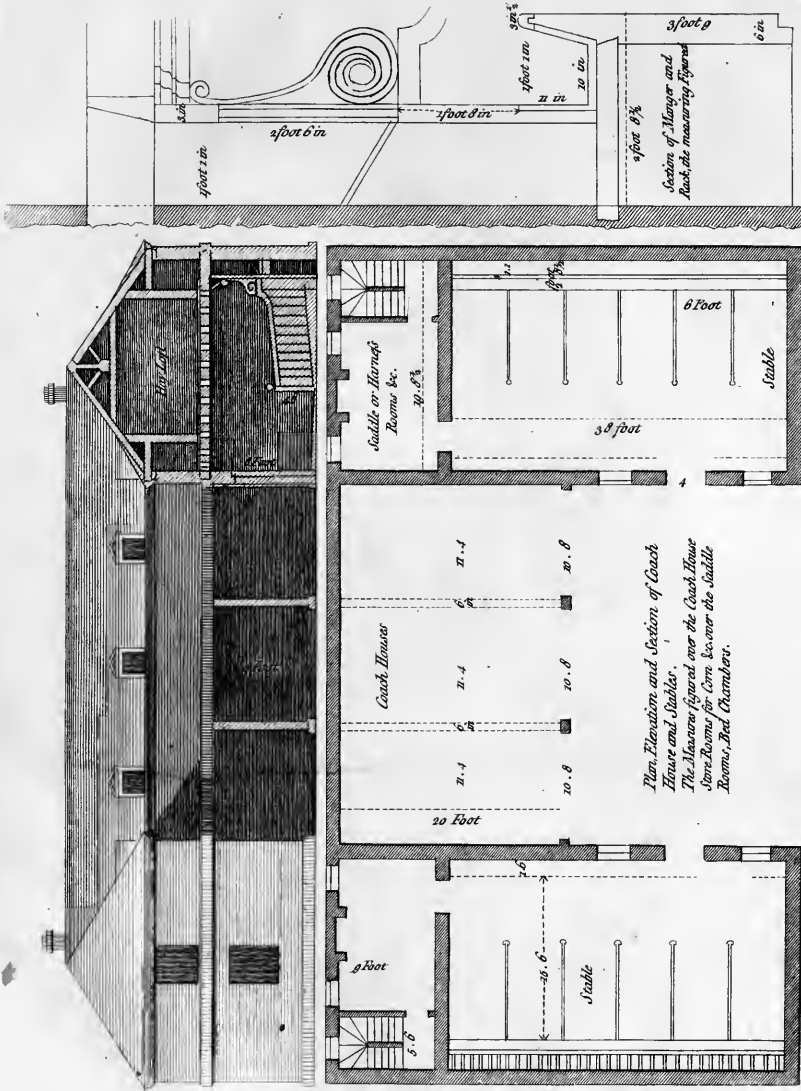

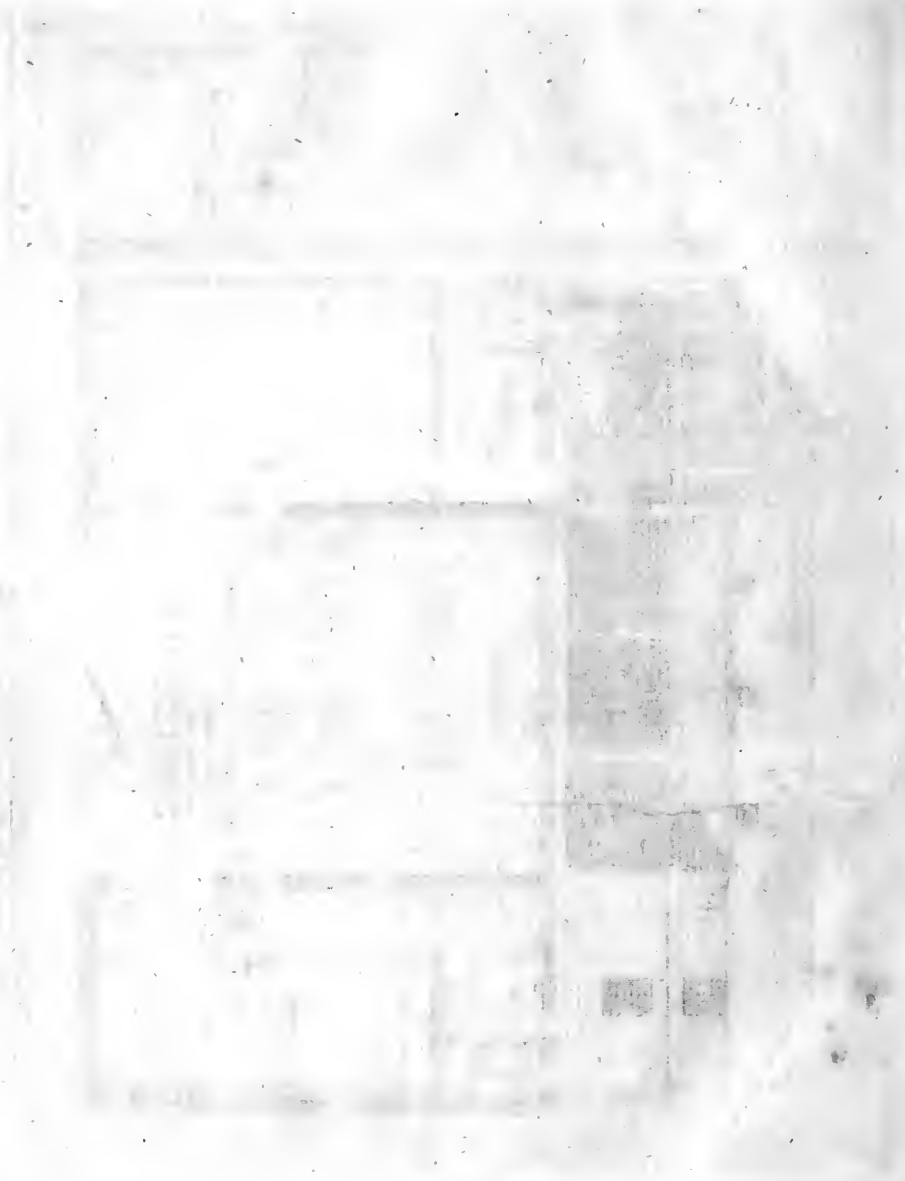

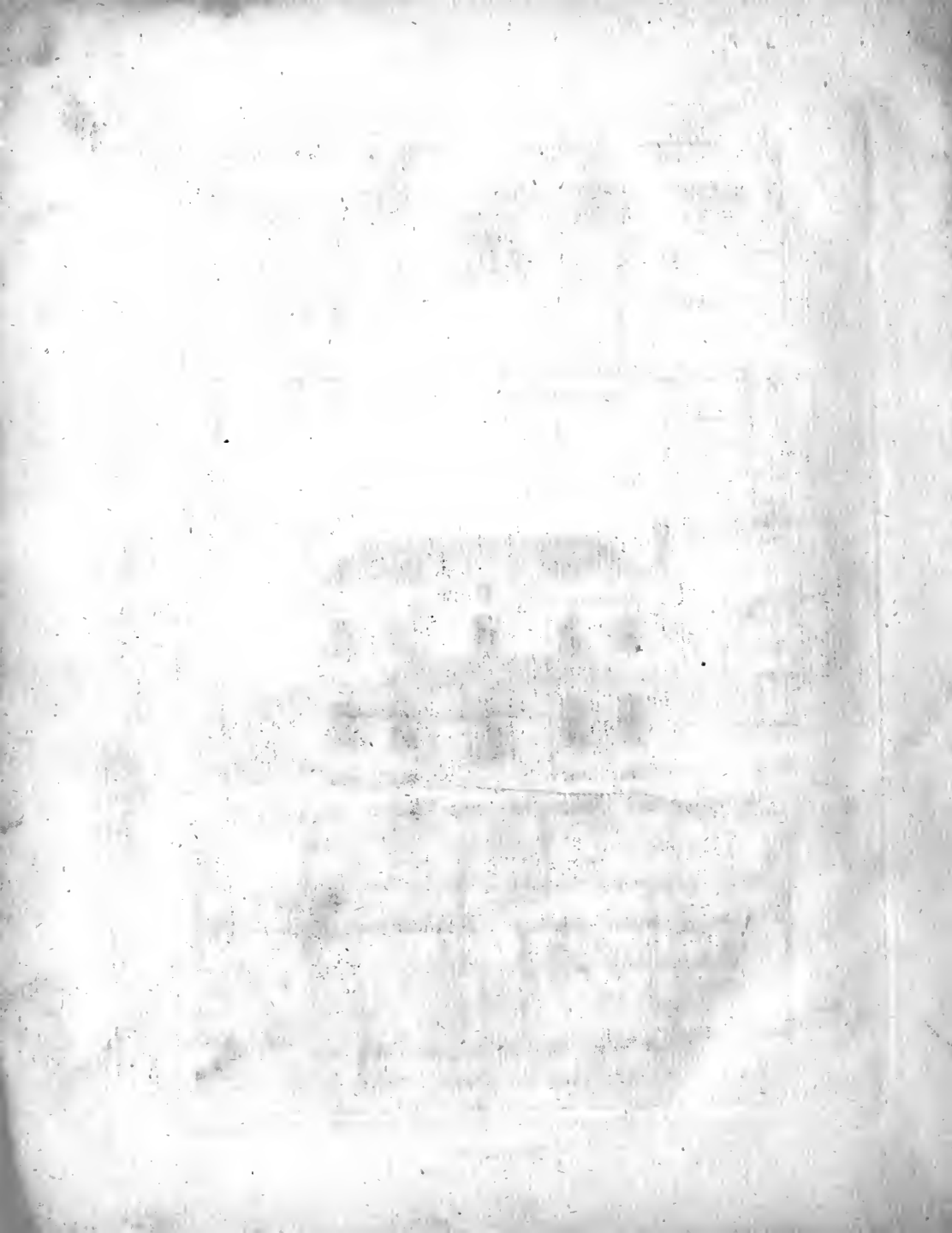

Plan, Elevation & Section &c. of a Farm-house Barns, Stables &c. Plate LXXXIII.

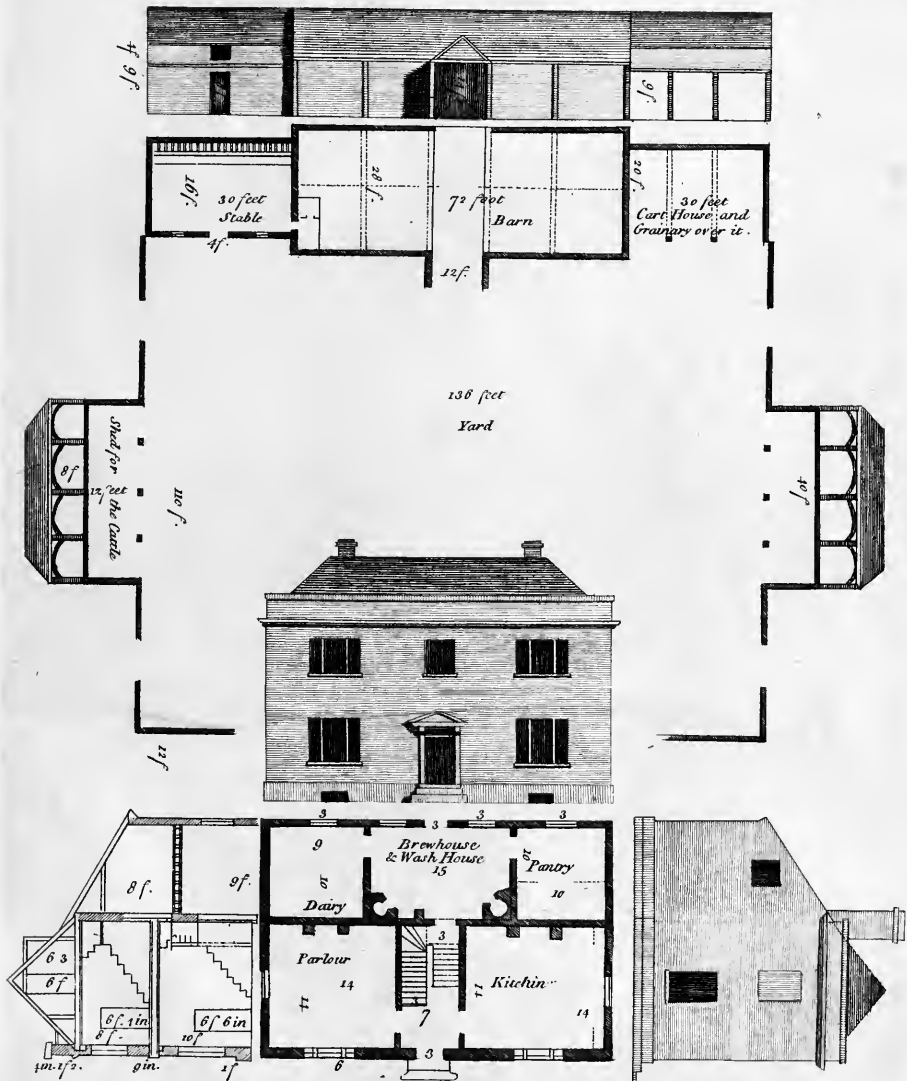

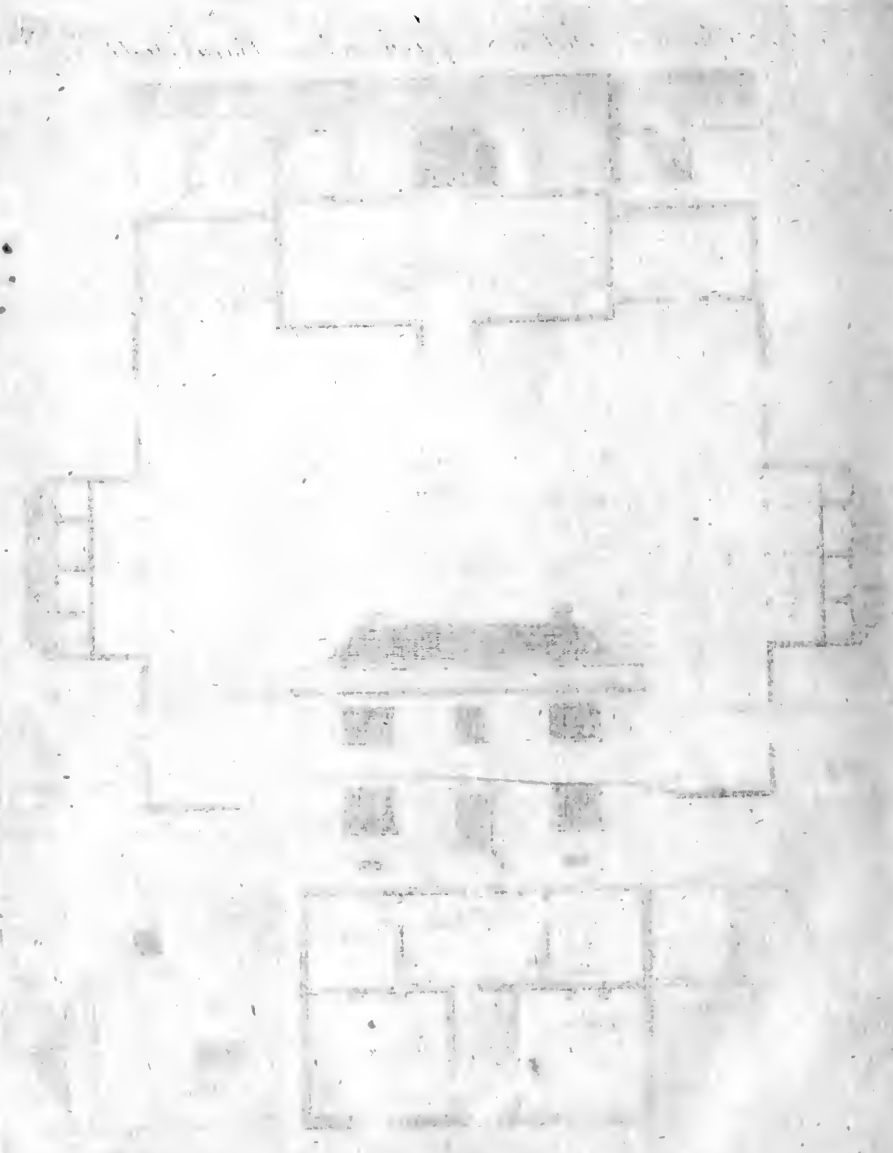

BOOKS printed for and sold by I. TAYLOR.

1 **T**HE Carpenter's Treasure; a Collection of Designs for Temples, with their Plans, Gates, Doors, Rails, and Bridges, in the Gothic Taste; with the Centres at large, for striking Gothic Curves and Mouldings; and some Specimens of Rails, in the Chinese Taste: Forming a complete System for rural Decorations. Neatly engraved on sixteen Plates, from the original Drawings of N. WALLIS, Architect 2s. 6d.

2. A Book of Ornaments in the Palmyrene Taste, containing upwards of sixty new Designs for Ceilings, Pannels, Pateras, and Mouldings: with the Raffle Leaves at large: By N. WALLIS, Architect, elegantly engraved on 12 Plates. 4s. 6d. sewed.

3. The Compleat Modern Joiner, or a Collection of original Designs in the present Taste, for Chimney-Pieces and Door-Cases, with their Mouldings and Enrichments at large; Frizes, Tablets, Ornaments for Pilasters, Bases, Sub-bases and Cornices for Rooms, &c. with a Table shewing the Proportion of Chimnies, with their Entablatures, to Rooms of any Size. By N. WALLIS, Architect. 8s. sewed, bound 10s.

Note, Both the above Books sew'd in one, 12s. or 14s. bound.

4. A new Book of Ornaments, designed by T. LAWS, Carver. 2s. sewed.

5. A new Book of Foliage, on ten Plates, for the Use of Learners, &c. By H. Gerrard. 2s. fd.

6. The Gentleman and Tradesman's Compleat Assistant, or the whole Art of Measuring and Estimating made Easy; containing the Names and Prices of all Artificers Work in general, relating to Building, viz. Bricklayers, Carpenters, Joiners, Carvers, Plasterers, Painters, Pavicers, Smiths, &c. 3s. 6d. sewed, 4s. 6d. bound.

7. LANGLEY's Builder's Chest-Book, or Key to the Five Orders of Architecture. Second Edition, much improv'd. 3s. bound.

8. Fourteen Vases from the Antique. 2s. sewed.

9. The Builder's Jewel. By B. LANGLEY. 4s. 6d. bound.

10. The Builder's Director, or Bench-Mate; on 184 Plates. 4s. bound.

11. HOPPUS's Practical Measurer, greatly enlarged and improved, 2s. 6d. bound.

12. The Modern Gardener, or Universal Kalendar; containing monthly Directions for all the Operations of Gardening; to be done either in the Kitchen, Fruit, Flower, or Pleasure Gardens: Illustrated with 13 Plates, neatly engraved, of entire new Plans for Stoves, Green-houses, &c. By JAMES MEADER, late Gardener to the EARL of CHESTERFIELD. 4s. sewed, 5s. bd.

13. The Stove-Grate Maker's Assistant, or a Treasury of Original and Fashionable Designs, for Bath-Stoves, Pennsylvania-Stoves, single and double Standard Grates, Frets, &c. By W. GLOSSOP, Stove-Grate Maker. Elegantly engraved on 24 Plates. 5s. sewed.

14. The Plan and Elevation (on two large Sheets) of that grand Structure *Mafra*, near Lisbon, the Palace of the King of Portugal, Price 6s.

15. A large Print of *Shoreditch-Church*. 3s.

16. A Print of *Greenwich Church*, 1s.

17. Health, an Essay on its Nature, Value, Uncertainty, Preservation and best Improvement. By B. GROSVENOR, D. D. 2s. 6d. bound.

18. *Le Beau's* Compendious French Teacher; to which are added, thirty-eight Letters of Commerce, in French, as Models to those who would chuse to form themselves to the useful Style of Epistolatory Correspondence. 2s. bound.

NOT FOR CIRCULATION

