



REESE LIBRARY
OF THE
UNIVERSITY OF CALIFORNIA.

Received *March* 1881

Accessions No. *14611*

Shelf No. *417*

F213

HYDRAULIC ENGINEERING

AND

M A N U A L

FOR

WATER SUPPLY ENGINEERS.



LIBRARY
UNIVERSITY OF
CALIFORNIA.



PUBLIC FOUNTAIN, CINCINNATI.

A

PRACTICAL TREATISE

ON

WATER-SUPPLY ENGINEERING:

RELATING TO THE

HYDROLOGY, HYDRODYNAMICS, AND PRACTICAL
CONSTRUCTION OF WATER-WORKS, IN
NORTH AMERICA.

WITH NUMEROUS

TABLES AND ILLUSTRATIONS,

BY

J. T. FANNING, C. E.,

MEMBER OF THE AMERICAN SOCIETY OF CIVIL ENGINEERS.

SECOND EDITION.

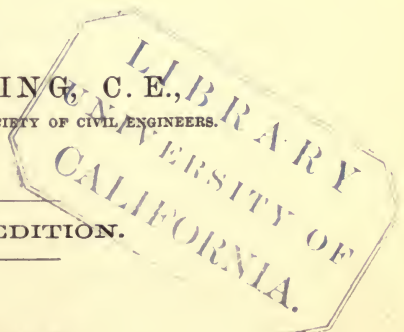

NEW YORK:

D. VAN NOSTRAND, PUBLISHER,

23 MURRAY STREET & 27 WARREN STREET.

1878.

743
F 2

COPYRIGHT, 1877,
BY
J. T. FANNING.
146 11

Electrotyped by
SMITH & McDOUGAL.

Printed by
H. J. HEWITT.

PREFACE TO THE SECOND EDITION.

THE author having been informed by the Publisher of this treatise that he has already had the sheets of a second edition struck off, and is about to hand them to the binder, gladly avails himself of the opportunity to thank his professional friends in practice and in training for the honor they have conferred, by taking up the first edition ere it is scarce six months out of the press, and to thank the scientific *press* generally for their kind criticisms and commendations; and he is especially glad to have opportunity so early to call attention to some typographical errors in the first edition, and to ask the purchasers to make the proper corrections therein, viz.:

In § 423, p. 423, equation 28, one h_1 was omitted. It should read,

$$P_1 = \frac{1}{2} w_2 \{ h_1 \sec \phi - (h_1^2 \tan^2 \phi + c_2^2)^{\frac{1}{2}} \}^2.$$

In the Appendix, p. 597, the decimal point in the weight per cubic inch of *metals* is one place too far to the left; thus, the weight of aluminum is printed .00972, but should read .0972.

No one can regret so much as the author that other duties have prevented a thorough revision and improvement of the work, so that it may be more worthy of so generous a reception.

J. T. F.

WATER SUPPLY ENGINEERING.—ERRATA.

Page 225. In line 10 the equation should read

$$\frac{v}{.815} - v = 14.85.$$

- “ 249. The eighth line from the bottom should read :
In which h" = the resistance head in feet.
- “ 266. In equation 19 insert the sign + before *m* in each of the three equations of *v*.
- “ 273. In line 15, after the word equation, strike out the words, “double the subdivisor 9,” and substitute, *to find the new value of v*. Also, in line 20 strike out the word “zero,” and substitute the word *unity*.
- “ 289. In the foot note, after the word deduct, substitute the following : from the total length, in feet, an amount equal to one-tenth the head upon the weir, in feet. Reduce the total length a like amount for each end contraction.
- “ 380. In table 80 the two equations of *Q* at heads of columns, are to change places.
- “ 487. In equation 20 place a decimal point before the divisor, thus : .3333S.
- “ 528. In table 108, in the four columns of *cubic feet per minute*, on this page, remove the decimal point one place further to the right.

P R E F A C E.

THERE is at present no sanitary subject of more general interest, or attracting more general attention, than that relating to the abundance and wholesomeness of domestic water supplies.

Each citizen of a densely populated municipality must of necessity be personally interested in either its physiological or its financial bearing, or in both. Each closely settled town and city must give the subject earnest consideration early in its existence.

At the close of the year 1875, fifty of the chief cities of the American Union had provided themselves with public water supplies at an aggregate cost of not less than ninety-five million dollars, and two hundred and fifty lesser cities and towns were also provided with liberal public water supplies at an aggregate cost of not less than fifty-five million dollars.

The amount of capital annually invested in newly inaugurated water-works is already a large sum, and is increasing, yet the entire American literature relating to water-supply engineering exists, as yet, almost wholly in reports upon individual works, usually in pamphlet form, and accessible each to but comparatively few of those especially interested in the subject.

Scores of municipal water commissions receive appointment each year in the growing young cities of the Union, who have to inform themselves, and pass judgment upon, sources and systems

of water supply, which are to become helpful or burdensome to the communities they are intended to encourage accordingly as the works prove successful or partially failures.

The individual members of these "Boards of Water Commissioners," resident in towns where water supplies upon an extended scale are not in operation, have rarely had opportunity to observe and become familiar with the varied practical details and apparatus of a water supply, or to acquaint themselves with even the elementary principles governing the design of the several different systems of supply, or reasons why one system is most advantageous under one set of local circumstances and another system is superior and preferable under other circumstances.

A numerous band of engineering students are graduated each year and enter the field, many of whom choose the specialty of *hydraulics*, and soon discover that their chosen science is great among the most noble of the sciences, and that its mastery, in theory and practice, is a work of many years of studious acquirement and labor. They discover also that the accessible literature of their profession, in the English language, is intended for the class-room rather than the field, and that its formulæ are based chiefly upon very limited philosophical experiments of a century and more ago but partially applicable to the extended range of modern practice.

Among the objects of the author in the compilation of the following pioneer treatise upon American Water-works are, to supply water-commissioners with a general review of the best methods practised in supplying towns and cities with water, and with facts and suggestions that will enable them to compare intelligently the merits and objectionable features of the different potable water sources within their reach; to present to junior and assistant hydraulic engineers a condensed summary of those elementary theoretical principles and the involved formulas adapted to modern practice, which they will have frequently to apply, together with some useful practical observations; to construct and gather, for the convenience of the older busy practitioners,

numerous tables and statistics that will facilitate their calculations, some of which would otherwise cost them, in the midst of pressing labors, as they did the author, a great deal of laborious research among rare and not easily procurable scientific treatises; and also to present to civil engineers generally a concise reference manual, relating to the hydrology, hydrodynamics, and practical construction of the water-supply branch of their profession.

This work is intended more especially for those who have already had a task assigned them, and who, as commissioner, engineer, or assistant, are to proceed at once upon their reconnoissance and surveys, and the preparation of plans for a public water supply. To them it is humbly submitted, with the hope that it will prove in some degree useful. Its aim is to develop the bases and principles of construction, rather than to trace the origin of, or to describe individual works. It is, therefore, practical in text, illustration, and arrangement; but it is hoped that the earnest, active young workers will find it in sympathy with their mood, and a practical introduction, as well, to more profound and elegant treatises that unfold the highest delights of the science.

Good design, which is invariably founded upon sound mathematical and mechanical theory, is a first requisite for good and judicious practical engineering construction. We present, therefore, the formulæ, many of them new, which theory and practical experiments suggest as aids to preliminary studies for designs, and many tables based upon the formulas, which will facilitate the labors of the designer, and be useful as checks against his own computations, and we give in addition such discussions of the elementary principles upon which the theories are founded as will enable the student to trace the origin of each formula; for a formula is often a treacherous guide unless each of its factors and experienced coefficients are well understood. To this end, the theoretical discussions are in familiar language, and the formulas in simple arrangement, so that a knowledge of elementary mathematics only is necessary to read and use them.

We do by no means intimate, however, that an acquaintance with elementary theories alone suffices for an accomplished engineer. It is sometimes said that genius spurns rules, and it is true that untutored genius sometimes grapples with and accomplishes great and worthy deeds, but too often in a bungling manner, not to be imitated.

In kindly spirit we urge the student to bear in mind that it is the rigorously trained genius who oftenest achieves mighty works by methods at once accurate, economical, artistic, and in every respect successful and admirable.

J. T. F.

BOSTON, *November, 1876.*

CONTENTS.

SECTION I.

COLLECTION AND STORAGE OF WATER, AND ITS IMPURITIES.

CHAPTER I.

INTRODUCTORY.—PAGE 25.

- Art. 1, Necessity of Public Water Supplies.—2, Physiological Office of Water.—3, Sanitary Office of Water Supplies.—4, Helpful Influence of Public Water Supplies.—5, Municipal Control of Public Water Supplies.—6, Value as an Investment.—7, Incidental Advantages.

CHAPTER II.

QUANTITY OF WATER REQUIRED.—PAGE 31.

- Art. 8, Statistics of Water Supplied.—9, Census Statistics.—10, Approximate Consumption of Water.—11, Water Supplied to Ancient Cities.—12, Water Supplied to European Cities.—13, Water Supplied to American Cities.—14, The Use of Water Steadily Increasing.—15, Increase in Various Cities.—16, Relation of Supply per Capita to Total Population.—17, Monthly and Hourly Variations in the Draught.—18, Ratio of Monthly Consumption.—19, Illustrations of Varying Consumption.—20, Reserve for Fire Extinguishment.

CHAPTER III.

RAINFALL.—PAGE 45.

- Art. 21, The Vapory Elements of Water.—22, The Liquid and Gaseous Successions.—23, The Source of Showers.—24, General Rainfall.—25, Review of Rainfall Statistics.—26, Climatic Effects.—27, Sections of Maximum Rainfall.—28, Western Rain System.—29, Central Rain System.—30, Eastern Coast System.—31, Influence of Elevation upon Precipitation.—32, River Basin Rains.—33, Grouped Rainfall Statistics.—34, Monthly Fluctuations

in Rainfall.—35, Secular Fluctuations in Rainfall.—36, Local Physical and Meteorological Influences.—37, Uniform Effects of Natural Laws.—38, Great Rain Storms.—39, Maximum Ratios of Floods to Rainfalls.—40, Volume of Water from given Rainfalls.—41, Gauging Rainfalls.

CHAPTER IV.

FLOW OF STREAMS.—PAGE 65.

Art. 42, Flood Volumes Inversely as the Areas of Basins.—43, Formulas for Flood Volumes.—44, Table of Flood Volumes.—45, Seasons of Floods.—46, Influence of Absorption and Evaporation upon Flow.—47, Flow in Seasons of Minimum Rainfall.—48, Periodic Classification of available Flow.—49, Sub-surface Equalizers of Flow.—50, Flashy and Steady Streams.—51, Peculiar Watersheds.—52, Summaries of Monthly Flow Statistics.—53, Minimum, Mean, and Flood Flow of Streams.—54, Ratios of Monthly Flow in Streams.—55, Mean Annual Flow of Streams.—56, Estimates of Flow of Streams.—57, Ordinary Flow of Streams.—58, Tables of Flow, Equivalent to given Depths of Rain.

CHAPTER V.

STORAGE AND EVAPORATION OF WATER.—PAGE 84.

STORAGE.—Art. 59, Artificial Storage.—60, Losses Incident to Storage.—61, Sub-strata of the Storage Basin.—62, Percolation from Storage Basins.—63, Rights of Riparian Owners.—64, Periodical Classification of Riparian Rights.—65, Compensations.—EVAPORATION.—66, Loss from Reservoir by Evaporation.—67, Evaporation Phenomena.—68, Evaporation from Water.—69, Evaporation from Earth.—70, Examples of Evaporation.—71, Ratios of Evaporation.—72, Resultant Effect of Rain and Evaporation.—73, Practical Effect upon Storage.

CHAPTER VI.

SUPPLYING CAPACITY OF WATER—SHEDS.—PAGE 94.

Art. 74, Estimate of Available Annual Flow of Streams.—75, Estimate of Monthly available Storage Required.—76, Additional Storage Required.—77, Utilization of Flood Flows.—78, Qualification of Deduced Ratios.—79, Influence of Storage upon a Continuous Supply.—80, Artificial Gathering Areas.—81, Recapitulation of Rainfall Ratios.

CHAPTER VII.

SPRINGS AND WELLS.—PAGE 102.

Art. 82, Subterranean Waters.—83, Their Source, the Atmosphere.—84, Porosity of Earths and Rocks.—85, Percolations in the Upper Strata.—86, The Courses of Percolation.—87, Deep Percolations.—88, Subterranean

Reservoirs.—89, The Uncertainties of Subterranean Searches.—90, Renowned Application of Geological Science.—91, Conditions of Overflowing Wells.—92, Influence of Wells upon each other.—93, American Artesian Wells.—94, Watersheds of Wells.—95, Evaporation from Soils.—96, Supplying Capacity of Wells and Springs.

CHAPTER VIII.

IMPURITIES OF WATER.—PAGE 112.

Art. 97, The Composition of Water.—98, Solutions in Water.—99, Properties of Water.—100, Physiological Effects of the Impurities of Water.—101, Mineral Impurities.—102, Organic Impurities.—103, Tables of Analyses of Potable Waters.—104, Ratios of Standard Gallons.—105, Atmospheric Impurities.—106, Sub-surface Impurities.—107, Deep-well Impurities.—108, Hardening Impurities.—109, Temperature of Deep Sub-surface Waters.—110, Decomposing Organic Impurities.—111, Vegetal Organic Impurities.—112, Vegetal Organisms in Water-pipes.—113, Animate Organic Impurities.—114, Propagation of Aquatic Organisms.—115, Purifying Office of Aquatic Life.—116, Intimate Relation between Grade of Organisms and Quality of Water.—117, Animate Organisms in Water-pipes.—118, Abrasion Impurities in Water.—119, Agricultural Impurities.—120, Manufacturing Impurities.—121, Sewage Impurities.—122, Impure Ice in Drinking-Water.—123, A Scientific Definition of Polluted Water.

CHAPTER IX.

WELL, SPRING, LAKE, AND RIVER SUPPLIES.—PAGE 139.

WELL WATERS.—Art. 124, Locations for Wells.—125, Fouling of Old Wells.—
 SPRING WATERS.—126, Harmless Impregnations.—127, Mineral Springs.—
 LAKE WATERS.—128, Favorite Supplies.—129, Chief Requisites.—130, Impounding.—131, Plant Growth.—132, Strata Conditions.—133, Plant and Insect Agencies.—134, Preservation of Purity.—135, Natural Clarification.—136, Great Lakes.—137, Dead Lakes.—RIVER WATERS.—138, Metropolitan Supplies.—139, Harmless and Beneficial Impregnations.—140, Pollutions.—141, Sanitary Discussions.—142, Inadmissible Polluting Liquids.—143, Precautionary Views.—144, Speculative Condition of the Pollution Question.—145, Spontaneous Purification.—146, Artificial Clarification.—147, A Sugar Test of the Quality of Water.

SECTION II.

FLOW OF WATER THROUGH SLUICES, PIPES, AND CHANNELS.

CHAPTER X.

WEIGHT, PRESSURE, AND MOTION OF WATER.—PAGE 161.

Art. 148, Special Characteristics of Water.—149, Atomic Theory.—150, Molecular Theory.—151, Influence of Caloric.—152, Relative Densities and Volumes.—WEIGHT OF WATER.—153, Weight of Constituents of Water.—154, Crystalline Forms of Water.—155, Formula for Volumes at Different Temperatures.—156, Weight of Pond Water.—157, Compressibility and Elasticity of Water.—158, Weights of Individual Molecules.—159, Individual Molecular Actions.—PRESSURE OF WATER.—160, Pressure Proportional to Depth.—161, Individual Molecular Reactions.—162, Equilibrium destroyed by an Orifice.—163, Pressures from Vertical, Inclined, and Bent Columns of Water.—164, Artificial Pressure.—165, Pressure upon a Unit of Surface.—166, Equivalent Forces.—167, Weight a Measure of Pressure.—168, A Line a Measure of Weight.—169, A Line a measure of Pressure upon a Surface.—170, Diagonal Force of Combined Pressures Graphically Represented.—171, Angular Resultant of a Force Graphically Represented.—172, Angular Effects of a Force Represented by the Sine and Cosine of the Angle.—173, Total Pressure.—174, Direction of Maximum Effect.—175, Horizontal and Vertical Effects.—176, Centres of Pressure and of Gravity.—177, Pressure upon a Curved Surface, and Effect upon its Projected Plane.—178, Centre of Pressure upon a Circular Area.—179, Combined Pressures.—180, Sustaining Pressure upon Floating and Submerged Bodies.—181, Upward Pressure upon a Submerged Lintel.—182, Atmospheric Pressure.—183, Rise of Water into a Vacuum.—184, Siphon.—185, Transmission of Pressure to a Distance.—186, Inverted Syphon.—187, Pressure Convertible into Motion.—MOTION OF WATER.—188, Flow of Water.—189, Action of Gravity upon Individual Molecules.—190, Frictionless Movement of Molecules.—191, Acceleration of Motion.—192, Equations of Motion.—193, Parabolic Path of Jet.—194, Velocity of Efflux Proportional to the Head.—195, Conversion of the Force of Gravity from Pressure into Motion.—196, Resultant Effects of Pressure and Gravity upon the Motion of a Jet.—197, Equal Pressures give Equal Velocities in all Directions.—198, Resistance of the Air.—199, Theoretical Velocities.

CHAPTER XI.

FLOW OF WATER THROUGH ORIFICES.—PAGE 194.

Art. 200, Motion of the Individual Particles.—201, Theoretical Volume of Efflux.—202, Converging Path of Particles.—203, Classes of Orifices.—

204, Form of Submerged Orifice Jet.—205, Ratio of Minimum Section of Jet.—206, Volume of Efflux.—207, Coefficient of Efflux.—208, Maximum Velocity of the Jet.—209, Factors of the Coefficient of Efflux.—210, Practical Use of a Coefficient.—211, Experimental Coefficients. (From Micheltotti, Abbe Bosset, Rennie, Castel, Lespinasse, General Ellis.)—212, Coefficients Diagramed.—213, Effect of Varying the Head, or the Proportions of the Orifice.—214, Peculiarities of Efflux from an Orifice.—215, Mean Velocity of the Issuing Particles.—216, Coefficients of Velocity and Contraction.—217, Velocity of Particles Dependent upon their Angular Positions.—218, Equation of Volume of Efflux from a Submerged Orifice.—219, Effect of Outline of Geometrical Orifices upon Efflux.—220, Variable Value of Coefficients.—221, Assumed Mean Value of Efflux.—222, Circular Jets, Polygonal do., Complex do.—223, Cylindrical and Divergent Orifices.—224, Converging Orifices.

CHAPTER XII.

FLOW OF WATER THROUGH SHORT TUBES.—PAGE 213.

Art. 225, An Ajutage.—226, Increase of Coefficient.—227, Ajutage Vacuum, and its Effect.—228, Increased Volume of Efflux.—229, Imperfect Vacuum.—230, Divergent Tube.—231, Convergent Tube.—232, Additional Contraction.—233, Coefficients of Convergent Tubes.—234, Increase and Decrease of Coefficient of Smaller Diameter.—235, Coefficient of Final Velocity.—236, Inward Projecting Ajutage.—237, Compound Tube.—238, Coefficients of Compound Tubes.—239, Experiments with Cylindrical and Compound Tubes.—240, Tendency to Vacuum.—241, Percussive Force of Particles.—242, Range of Eytelwein's Table.—243, Cylindrical Tubes to be Preferred.

CHAPTER XIII.

FLOW OF WATER THROUGH PIPES, UNDER PRESSURE.—
PAGE 223.

Art. 244, Pipe and Conduit.—245, Short Pipes give Greatest Discharge.—246, Theoretical Volume from Pipes.—247, Mean Efflux from Pipes.—248, Subdivision of the Head.—249, Mechanical Effect of the Efflux.—250, Ratio of Resistance at Entrance to the Pipe.—RESISTANCE TO FLOW WITHIN A PIPE.—251, Resistance of Pipe-Wall.—252, Conversion of Velocity into Pressure.—253, Coefficients of Efflux from Pipes.—254, Reactions from the Pipe-Wall.—255, Origin of Formulas of Flow.—256, Formula of Resistance to Flow.—257, Coefficient of Flow.—258, Opposition of Gravity and Reaction.—259, Conversion of Pressure into Mechanical Effect.—260, Measure of Resistance to Flow.—261, Resistance Inversely as the Square of the Velocity.—262, Increase of Bursting Pressure.—263, Acceleration and Resistance.—264, Equation of Head Required to Overcome the Resistance.—265, Designation of h' and l .—266, Variable Value of m .—267, Investigation of Values of m .—268, Definition of Symbols.—269, Experi-

mental Values of the Coefficient of Flow.—270, Peculiarities of the Coefficient (m) of Flow.—271, Effects of Tubercles.—272, Classification of Pipes and their Mean Coefficients.—273, Equation of the Velocity Neutralized by Resistance to Flow.—274, Equation of Resistance Head.—275, Equation of Total Head.—276, Equation of Volume.—277, Equation of Diameter.—278, Relative Value of Subdivisions of Total Head.—279, Many Popular Formulas Incomplete.—280.—Formula of M. Chezy.—281, Various Popular Formulas Compared.—282, Sub-heads Compared.—283, Investigations by Dubuat, and Coloumb, and Prony.—284, Prony's Analysis.—285, Eytelwein's Equation of Resistance to Flow.—286, D'Abuissou's Equation of Resistance to Flow.—287, Weisbach's Equation of Resistance to Flow.—288, Transpositions of an Original Formula.—289, Unintelligent Use of Partial Formulas.—290, A Formula of more General Application.—291, Values of v for Given Slopes.—292, Values of h and h' for Given Velocities.—293, Classified Equations for Velocity, Head, Volume, and Diameter.—294, Coefficients of Entrance of Jet.—295, Mean Coefficients for Smooth, Rough, and Foul Pipes.—296, Mean Equations for Smooth, Rough, and Foul Pipes.—297, Modification of a Fundamental Equation of Velocity.—298, Values of l' .—299, Bends.—300, Branches.—301, How to Economize Head.

CHAPTER XIV.

MEASURING WEIRS, AND WEIR GAUGING.—PAGE 277.

Art. 302, Gauged Volumes of Flow.—303, Form of Weir.—304, Dimensions.—305, Stability.—306, Varying Length.—307, End Contractions.—308, Crest Contractions.—309, Theory of Flow over a Weir.—310, Formulas for Flow, without and with Contractions.—311, Increase of Volume due to Initial Velocity of Water.—312, Coefficients for Weir Formulas.—313, Discharges for Given Depths.—314, Vacuum under the Crest.—315, Examples of Initial Velocity.—316, Wide-crested Weirs.—317, Triangular-Notch Weirs.—318, Obstacles to Accurate Measures.—319, Hook Gauge.—320, Rule Gauge.—321, Tube and Scale Gauge.

CHAPTER XV.

FLOW OF WATER IN OPEN CHANNELS.—PAGE 299.

Art. 322, Gravity the Origin of Flow.—323, Resistance to Flow.—324, Equations of Resistance and Velocity.—325, Equation of Inclination.—326, Coefficients of Flow for Channels.—327, Observed Data of Flow in Channels.—328, Table of Coefficients for Channels.—329, Various Formulas of Flow Compared.—330, Velocities of Given Films.—331, Surface Velocities.—332, Ratios of Surface to Mean Velocities.—333, Hydrometer Gaugings.—334, Tube Gauges.—335, Gauge Formulas.—336, Pitot Tube Gauge.—337, Woltmann's Tachometer.—338, Hydrometer Coefficients.—339, Henry's Telegraphic Moulinet.—340, Earlier Hydrometers.—341, Double Floats.—342, Mid-depth Floats.—343, Maximum Velocity Floats.—344, Relative Velocities and Volumes due to Different Depths.

SECTION III.

PRACTICAL CONSTRUCTION OF WATER-WORKS.

CHAPTER XVI.

RESERVOIR EMBANKMENTS AND CHAMBERS.—PAGE 333.

Art. 345, Ultimate Economy of Skillful Construction.—346, Embankment Foundations.—347, Springs under Foundations.—348, Surface Soils.—349, Concrete Cut-off Walls.—350, Treacherous Strata.—351, Embankment Core Materials.—352, Peculiar Pressures.—353, Earthwork Slopes.—354, Reconnaissance for Site.—355, Detailed Surveys.—356, Illustrative Case.—357, Cut-off Wall.—358, Embankment Core.—359, Frost Covering.—360, Slope Paving.—361, Puddle Wall.—362, Rubble Priming Wall.—363, A Light Embankment.—364, Distribution Reservoirs.—365, Application of Fine Sand.—366, Masonry-Faced Embankment.—367, Concrete Paving.—368, Embankment Sluices and Pipes.—369, Gate Chambers.—370, Sluice Valve Areas.—371, Stop-valve Indicator.—372, Power required to Open a Valve.—373, Adjustable Effluent Pipe.—374, Fish Screens.—375, Gate Chamber Foundations.—376, Foundation Concrete.—377, Chamber Walls.

CHAPTER XVII.

OPEN CANALS.—PAGE 370.

Art. 378, Canal Banks.—379, Inclinations and Velocities in Practice.—380, Ice Covering.—381, Table of Dimensions of Supply Canals.—382, Canal Gates.—383, Miners' Canals.

CHAPTER XVIII.

WASTE WEIRS.—PAGE 377.

Art. 384, The Office and Influence of a Waste-Weir.—385, Discharges over Waste-Weirs.—386, Required Lengths of Waste-Weirs.—387, Forms of Waste-Weirs.—388, Isolated Weirs.—389, Timber Weirs.—390, Ice-Thrust upon Storage Reservoir Weirs.—391, Breadths of Weir-Caps.—392, Thicknesses of Waste-Weirs and Dams.—393, Force of Overflowing Water.—394, Heights of Waves.

CHAPTER XIX.

PARTITIONS AND RETAINING WALLS.—PAGE 390.

Art. 395, Design.—396, Theory of Water-Pressure upon a Vertical Surface.—397, Water Pressure upon an Inclined Surface.—398, Frictional Stability

of Masonry.—399, Coefficients of Masonry Friction.—400, Pressure Leverage of Water.—401, Leverage Stability of Masonry.—402, Moment of Weight Leverage of Masonry.—403, Thickness of a Vertical Rectangular Wall for Water Pressure.—404, Moments of Rectangular and Trapezoidal Sections.—405, Graphical Method of Finding the Leverage Resistance.—406, Granular Stability.—407, Limiting Pressures.—408, Table of Walls for Quiet Water.—409, Economic Profiles.—410, Theory of Earth Pressures.—411, Equation of Weight of Earth Wedge.—412, Equation of Pressure of Earth Wedge.—413, Equation of Moment of Pressure Leverage.—414, Thickness of a Vertical Rectangular Wall for Earth Pressure.—415, Surcharged Earth Wedge.—416, Pressure of a Surcharged Earth Wedge.—417, Moment of a Surcharged Pressure Leverage.—418, Pressure of an Infinite Surcharge.—419, Resistance of Masonry Revetments.—420, Final Resultants in Revetments.—421, Table of Trapezoidal Revetments.—422, Curved-face Batter Equation.—423, Back Batters and their Equations.—424, Inclination of Foundation.—425, Front Batters and Steps.—426, Top Breadth.—427, Wharf Walls.—428, Counterforted Walls.—429, Elements of Failure.—430, End Supports.—431, Faced and Concrete Revetments.

CHAPTER XX.

MASONRY CONDUITS.—PAGE 431.

Art. 432, Protection of Channels for Domestic Water Supplies.—433, Examples of Conduits.—434, Foundations of Conduits.—435, Conduit Shells.—436, Ventilation of Conduits.—437, Conduits under Pressure.—438, Protection from Frost.—439, Masonry to be Self-sustaining.—440, A Concrete Conduit.—441, Example of a Conduit under Heavy Pressure.—442, Mean Radii of Conduits.—443, Formulas of Flow for Conduits.—444, Table of Conduit Data.

CHAPTER XXI.

MAINS AND DISTRIBUTION PIPES.—PAGE 446.

Art. 445, Static Pressures in Pipes.—446, Thickness of Shell resisting Static Pressure.—447, Water-Ram.—448, Formulas of Thickness for Ductile Pipes.—449, Strengths of Wrought Pipe Metals.—450, Moulding of Pipes.—451, Casting of Pipes.—452, Formulas of Thickness for Cast-iron Pipes.—453, Thicknesses found Graphically.—454, Table of Thicknesses of Cast-iron Pipes.—455, Table of Equivalent Fractional Expressions.—456, Cast-iron Pipe-Joints.—457, Dimensions of Pipe-Joints.—458, Templets for Bolt Holes.—459, Flexible Pipe-Joint.—460, Thickness Formulas Compared.—461, Formulas for Weights of Cast-iron Pipes.—462, Table of Weights of Cast-iron Pipes.—463, Interchangeable Joints.—464, Characteristics of Pipe Metals.—465, Tests of Pipe-Metals.—466, The Preservation of Pipe Surfaces.—467, Varnishes for Pipes and Iron Work.—468, Hydraulic Proof of Pipes.—469, Special Pipes.—470, Cement-lined and

Coated Pipes.—471, Methods of Lining.—472, Covering.—473, Cement Joints.—474, Cast Hub Joint.—475, Composite Branches.—476, Thickness of Shells for Cement Linings.—477, Gauge Thickness and Weights of Rolled Iron.—478, Lining, Covering, and Joint Mortar.—479, Asphaltum-Coated Wrought-iron Pipes.—480, Asphaltum Bath, for Pipes.—481, Wrought Pipe Plates.—482, Bored Pipes.—483, Wyckoff's Patent Pipe.

CHAPTER XXII.

DISTRIBUTION SYSTEMS, AND APPENDAGES.—PAGE 493.

Art. 484, Loss of Head by Friction.—485, Table of Frictional Heads in Pipes.—486, Relative Discharging Capacities of Pipes.—487, Table of Relative Capacities of Pipes.—488, Depths of Pipes.—489, Elementary Dimensions of Pipes.—490, Distribution Systems.—491, Rates of Consumption of Water.—492, Rates of Fire Supplies.—493, Diameter of Supply Main.—494, Diameters of Sub-mains.—495, Maximum Velocities of Flow.—496, Comparative Frictions.—497, Relative Rates of Flow for Domestic and Fire Supplies.—498, Required Diameters for Fire Supplies.—499, Duplication Arrangement of Sub-Mains.—500, Stop-Valve Systems.—501, Stop-Valve Locations.—502, Blow-off and Waste Valves.—503, Stop-Valve Details.—504, Valve Curbs.—505, Fire Hydrants.—506, Post Hydrants.—507, Hydrant Details.—508, Flush Hydrants.—509, Gate Hydrants.—510, High Pressures.—511, Air Valves.—512, Union of High and Low Services.—513, Combined Reservoir and Direct Systems.—514, Stand Pipes.—515, Frictional Heads in Service-Pipes.

CHAPTER XXIII.

CLARIFICATION OF WATER.—PAGE 530.

Art. 516, Rarity of Clear Waters.—517, Floating Débris.—518, Mineral Sediments.—519, Organic Sediments.—520, Organic Solutions.—521, Natural Processes of Clarification.—522, Chemical Processes of Clarification.—523, Charcoal Process.—524, Infiltration.—525, Infiltration Basins.—526, Examples of Infiltration.—527, Practical Considerations.—528, Examples of European Infiltration.—529, Example of Intercepting Well.—530, Filter Beds.—531, Settling and Clear-Water Basins.—532, Introduction of Filter-Bed System.—533, Capacity of Filter Beds.—534, Cleaning of Filter Beds.—535, Renewal of Sand Surface.—536, Basin Coverings.

CHAPTER XXIV.

PUMPING OF WATER.—PAGE 557.

Art. 537, Types of Pumps.—538, Prime Movers.—539, Expense of Variable Delivery of Water.—540, Variable Motions of a Piston.—541, Ratios of Variable Delivery of Water.—542, Office of Stand-Pipe and Air-Vessel.—

543, Capacities of Air-Vessels.—544, Valves.—545, Motions of Water through Pumps.—546, Double-Acting Pumping Engines.—547, Geared Pumping Engines.—548, Costs of Pumping Water.—549, Duty of Pumping Engines.—550, Special Trial Duties.—551, Economy of a High Duty.

CHAPTER XXV.

SYSTEMS OF WATER SUPPLY.—PAGE 585.

Art. 552, Permanence of Supply Essential.—553, Methods of Gathering and Delivering Water.—554, Gravitation.—555, Choice of Water.—556, Pumping with Reservoir Reserve—557, Pumping with Direct Pressure.

LIST OF TABLES.

Table No.	Page
1. Population, Families, and Dwellings in Fifty American Cities.....	32
2. Water Supplied, and Piping in several Cities.....	38
3. Water Supplied in years 1870 and 1874.....	39
4. Average Gallons of Water Supplied to each Inhabitant.....	40
5. Ratios of Monthly Consumption of Water in 1874.....	43
6. Mean Rainfall in different River Basins	51
7. Rainfall in the United States.....	53
8. Volumes of Rainfall per minute for given inches of Rain per twenty-four hours.....	62
9. Flood Volumes from given Watershed Areas.....	67
10. Summary of Rainfall upon the Cochituate Basin.....	72
11. Summary of Rainfall upon the Croton Basin.....	72
12. Summary of Rainfall upon the Croton West-Branch Basin.....	73
13. Summary of Percentage of Rain Flowing from the Cochituate Basin...	73
14. Summary of Percentage of Rain Flowing from the Croton Basin.....	73
15. Summary of Percentage of Rain Flowing from the Croton West-Branch Basin.....	74
16. Summary of Volume of Flow from the Cochituate Basin	74
17. Summary of Volume of Flow from the Croton Basin.....	74
18. Summary of Volume of Flow from the Croton West-Branch Basin....	75
19. Estimates of Minimum, Mean, and Maximum Flow of Streams.....	75
20. Monthly Ratios of Flow of Streams.....	76
21. Ratios of Mean Monthly Rain and Inches of Rain Flowing each Month	77
22. Equivalent Volumes of Flow for given Depths of Rain in One Month.	82
23. Equivalent Volumes of Flow for given Depths of Rain in One Year..	83
24. Evaporation from Water	89
25. Mean Evaporation from Earth.....	89
26. Monthly Ratios of Evaporation from Reservoirs.....	92
27. Multipliers for Equivalent Inches of Rain Evaporated.....	92
28. Monthly Supply to and Draft from a Reservoir (with Compensation)..	96
29. Monthly Supply to and Draft from a Reservoir (without Compensation)	97
30. Ratios of Monthly Rain, Flow, Evaporation, and Consumption.....	101
31. Percolation of Rain into One Square Mile of Porous Soil.....	111
32. Analyses of Various Lake, Spring, and Well Waters	117
33. Analyses of Various River and Brook Waters.....	118
34. Analyses of Various Streams in Massachusetts.....	120
35. Analyses of Various Water Supplies from Domestic Wells.....	121

Table No.	Page
36. Artesian Well Temperatures.....	127
37. Analyses of Various Mineral Spring Waters.....	143
38. Weights and Volumes of Water at Different Temperatures.....	166
39. Pressures of Water at Stated Depths.....	172
40. Correspondent Heights, Velocities, and Times of Falling Bodies.....	190
41. Coefficients from Michelotti's Experiments with Orifices.....	198
42. Coefficients from Bossut's Experiments with Orifices.....	199
43. Coefficients from Rennie's Experiments with Orifices.....	199
44. Coefficients from Lespinasse's Experiments with Orifices.....	201
45. Coefficients from General Ellis's Experiments with Orifices.....	203
46. Coefficients for Rectangular Orifices (vertical).....	205
47. Coefficients for Rectangular Orifices (horizontal).....	206
48. Castel's Experiments with Convergent Tubes.....	217
49. Venturi's Experiments with Divergent Tubes.....	219
50. Eytelwein's Experiments with Compound Tubes.....	220
51. Coefficients of Efflux (c) for Short Pipes.....	227
52. Experimental Coefficients of Flow (m) by Darcy.....	237
53. Experimental Coefficients of Flow (m) by Fanning.....	238
54. Experimental Coefficients of Flow (m) by Du Buat.....	238
55. Experimental Coefficients of Flow (m) by Bossut.....	238
56. Experimental Coefficients of Flow (m) by Couplet.....	239
57. Experimental Coefficients of Flow (m) by Provis.....	239
58. Experimental Coefficients of Flow (m) by Rennie.....	239
59. Experimental Coefficients of Flow (m) by Darcy.....	240
60. Experimental Coefficients of Flow (m) by General Greene and others..	240
61. Tabulated Series of Coefficients of Flow (m).....	242
62. Coefficients for Clean, Slightly Tuberculated, and Foul Pipes ...	248
63. Various Formulas for Flow of Water in Pipes.....	254
64. Velocities (v) for given Slopes and Diameters.....	259
65. Tables of h and h' due to given Velocities.....	264
66. Values of c_v and c for Tubes.....	267
66a. Sub-coefficients of Flow (c') in Pipes.....	271
67. Coefficients of Resistance in Bends.....	274
68. Experimental Weir Coefficients.....	288
69. Coefficients for given Depths upon Weirs.....	289
70. Discharge for given Depths upon Weirs.....	290
71. Weir Coefficients by Castel.....	291
72. Series of Weir Coefficients by Smeaton and others.....	291
73. Coefficients for Wide Weir-crests.....	294
74. Observed and Computed Flows in Canals and Rivers.....	307
75. Coefficients (m) for Open Channels.....	308
76. Various Formulas for Flow in Open Channels.....	310
77. Weights of Embankment Materials.....	341
78. Angles of Repose, and Frictions of Embankment Materials.....	345
79. Dimensions of Water Supply and Irrigation Canals.....	373
80. Waste-Weir Volumes for given Depths.....	380
81. Lengths and Discharges of Waste-Weirs.....	381

Table No.	Page
82. Thicknesses of Masonry Weirs and Dams	387
83. Heights of Reservoir and Lake Waves.....	388
84. Coefficients of Masonry Frictions.	396
85. Computed Pressures in Masonry.....	403
86. Limiting Pressures upon Masonry.....	404
87. Dimension of Walls to Retain Water.....	406
88. Dimension of Walls to Sustain Earth.....	420
89. Thicknesses of a Curved-face Wall.....	422
90. Hydraulic Mean Radii for Circular Conduits.....	442
90a. Coefficients (<i>m</i>) for Smooth Conduits.....	444
91. Conduit Data.....	445
92. Tenacities of Wrought Pipe Metals.....	451
93. Thicknesses of Cast-iron Pipes.....	455
93a. Thicknesses of Cast-iron Pipes as used in several Cities.....	456
94. Parts of an Inch and Foot expressed Decimally.....	457
95. Dimensions of Cast-iron Water-pipes.....	461
96. Flange Data of Flanged Cast-iron Pipes.....	462
97. Various Formulas for Thicknesses of Cast-iron Pipes.....	466
98. Weights of Cast-iron Pipes.....	468
98a. Weights of Cast-iron Pipes as used in several Cities.....	469
99. Thicknesses of Wrought-iron Pipe Shells.....	486
100. Thicknesses and Weights of Iron Plates	488
101. Frictional Head in Pipes.....	495
102. Relative Discharging Capacities of Pipes.....	500
103. Depths to lay Water-pipes in different Latitudes.....	502
104. Elementary Dimensions of Pipes.....	504
105. Maximum Advisable Velocity of Flow in Pipes.	508
106. Diameters of Pipes to supply given Numbers of Hose Streams.....	510
107. Experimental Volumes of Fire Hydrant Streams.....	520
108. Frictional Head in Service Pipes.....	528
109. Dimensions of Filter-beds for given Volumes.....	554
110. Piston Spaces for given Arcs of Crank Motion.....	562
111. Ratios of Piston Motions for given Crank Arcs.....	564
112. Costs of Pumping in Various Cities.....	575
113. Special Trial Duties of Various Pumping Engines.....	580
114. Comparative Consumptions of Coal at Different Duties.	581
115. Fuel Expenses for Pumping compared on Duty Bases.....	581
116. Comparison of Values of Pumping-Engines on Fuel Bases.....	583

LIST OF FULL PAGE ILLUSTRATIONS.

	PAGE
Public Fountain, Cincinnati.....	2
Gateway, Chestnut Hill Reservoir, Boston.....	24
Pumping Station, Toledo.....	31
Diagram of Pumping, Annual.....	42
Pumping Station, Milwaukee.....	45
Diagrams of Rainfall.....	55
Diagrams of Rainfall.....	57
Diagrams of Secular Rainfall.....	59
Section and Plan of Pump-House.....	65
Reservoir Embankment, Norwich.....	84
Intercepting Well, Prospect Park, Brooklyn.....	102
Pumping Station, New Bedford.....	139
Stand-Pipe, Boston.....	160
Pumping Station, Manchester.....	213
Compound Duplex Pumping Engine.....	223
Measuring Weir, for Turbine Test.....	277
Fairmount Turbines and Pumps, Philadelphia.....	332
Distributing Reservoir.....	333
Compound Inverted Pumping-Engine.....	377
Conduit Sections.....	431
Cylindrical Penstock.....	440
Forms of Pipe-Sockets and Spigots.....	446
Branch, Reducer and Bend.....	478
Double-Faced Stop-Valves.....	493
Plan of a Pipe System.....	505
Flush Fire Hydrants.....	521
Pumping-Engine, No. 3, Brooklyn.....	557
Cornish Plunge-Pump.....	563
Compound Beam Pumping-Engine, Lynn.....	567
Geared Pumping-Engine, Providence.....	573
Hydraulic Power Pumping Machinery, Manchester.....	585
Jonval Turbine.....	593

A P P E N D I X .

	Page
Metric Weights and Measures.....	593
Table of French Measures and United States Equivalents.....	594
Cubic Inch, and Equivalents.....	595
Gallon, and Equivalents.....	595
Cubic Foot, and Equivalents.....	595
Imperial Gallon, and Equivalents.....	596
Cubic Yard, and Equivalents.....	596
Table of Units of Heads and Pressures of Water, and Equivalents.....	596
Table of Average Weights, Strengths, and Elasticities of Materials.....	597
Formulas for Diameters and Strengths of Shafts.....	599
Trigonometrical Expressions.....	599
Trigonometrical Equivalents.....	600
Table of Sines, Tangents, &c.....	601
What Constitutes a Car Load.....	602
Lubricating Compounds for Gears.....	602
Compound for Cleaning Brass.....	602
Iron Cement, for Repairing Cracks in Castings.....	602
Alloys, Table of.....	603
Velocities of Flow in Channels, that Move Sediments.....	604
Tensile Strengths of Cements and Mortars.....	605
Dimensions of Bolts and Nuts.....	606
Weights of Lead and Tin-lined Service-Pipes.....	607
Meters and Meter Rates.....	608
Resuscitation from Death by Drowning.....	609



LIBRARY
UNIVERSITY OF
CALIFORNIA.

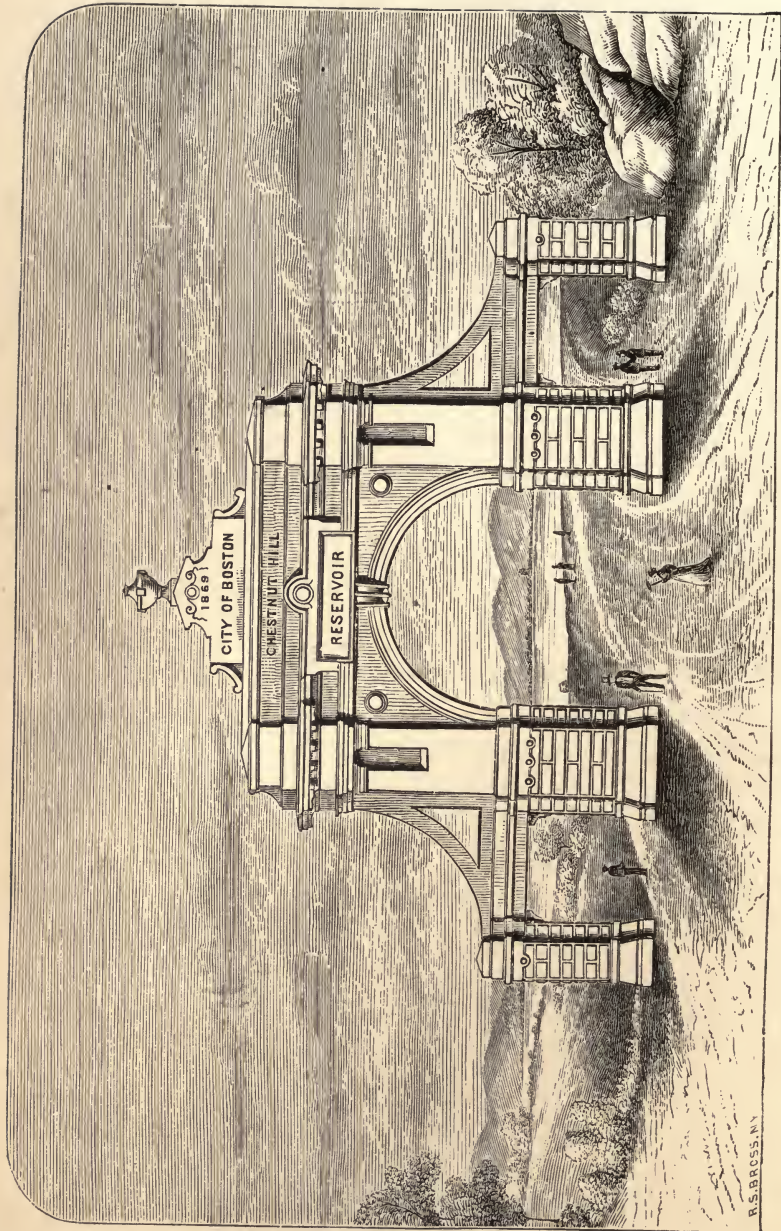

GATEWAY, CHESTNUT HILL RESERVOIR, BOSTON.



SECTION I.

COLLECTION AND STORAGE OF WATER, AND ITS IMPURITIES.

CHAPTER I.

INTRODUCTORY.

1. Necessity of Public Water Supplies.—A new or an additional water supply is an inevitable necessity whenever and wherever a new settlement establishes itself in an isolated position; again whenever the settlement receives any considerable increase; and again when it becomes a great metropolis or manufacturing centre.

In all the wonderful and complex transformations in Nature, in the sustenance of all organized beings, and in the convenience and delight of man, water is appointed to perform an important and essential part.

Life cannot long exist in either plant or animal, unless water, in some of its forms, is provided in due quantity.

Wholesome water is indispensable in the preparation of all our foods; clear and soft water is essential for promoting the cleanliness and health of our bodies; and pure water is demanded for a great variety of the operations of the useful and mechanic arts.

2. Physiological Office of Water.—Of the three essentials to human life, *air*, *water*, and *food*, the one now

to be specially considered, *water*, has for its physiological office to maintain all the tissues of the body in healthy action.

If the water received into the system is unfit for such special duty, all the animal functions suffer and are weakened, air then but partially clarifies the blood, food then is imperfectly assimilated, and the body degenerates.

Vigor is essential to the uniform success and happiness of every individual, and strength and happiness of the people are essential to good public morals, good public government, and sound public prosperity.

Sanitary improvements are, therefore, among the first and chief duties of public officers and guardians, and have ever been the objects of the most earnest thought and labor of great public philanthropists.

3. Sanitary Office of Public Water Supplies.—Water has thus far proved the most effectual and economical agent, as sanitary scavenger, in the removal from our habitations of waste slops and sewage, and also the most effectual* and economical agency in the protection of life and property from destruction by fire.

The necessity of a judiciously executed system of public water-supply increases as the population of a town increases; as the mass of buildings thickens; as the lands upon which the town is built become saturated with sewage, and the individual sources within the town are polluted; as the atmosphere over and within the town is fouled by gases

* We need refer to but one of many experiences, viz.: At Columbus, Ohio, the average loss by fire for the four years preceding the completion of the public water-works was $\frac{6.5}{100}$ of one per cent. of the valuation. The average loss during the first four years after the completion of the works was $\frac{1.8}{100}$, and during the fifth year, from April 1, 1875, to April 1, 1876, was $\frac{1.1}{100}$ of the valuation. These statistics show a probable saving in the first four years of upward of one-half million dollars, and in five years of more than the entire cost of the water-works.

arising therefrom ; and as the dangers of epidemics, fevers, and contagious diseases increase.

4. Helpful Influence of Public Water Supplies.—

No town or city can submit to a continued want of an adequate supply of pure and wholesome water without a serious check in its prosperity.

Capital is always wary of investment where the elements of safety and health are lacking, and industry dreads frequent failures and objectionable quality in its water supply.

It is true that considerations of profit sometimes induce the assembling of a town where potable waters are procurable with difficulty, but in such cases the lack is sure to prove a growing hindrance to its prosperity, and before the town arrives at considerable magnitude, its remedy will present one of the most difficult problems with which its municipal authorities are obliged to cope.

In the experience of all large and thriving cities, there has come a time when an additional or new and abundant water supply was a necessity, terribly real, that would not be talked down, or resolved out of existence by public meetings, or wait for a more convenient season ; a time when it was not possible for every citizen to supply his household or his place of business independently, or even for a majority of the citizens to do so, and when prompt, united, and systematic action must be taken to ensure the health, prosperity, and safety of the people. Such stern necessity often appears to present difficulties almost insurmountable by the available mechanical and financial resources of the citizens.

Out of such simple but positive necessities have grown the grandest illustrations, in our great public water supplies, of the benefits of co-operative action, recorded in the annals of political economy. Out of such simple necessi-

ties grew some of the most magnificent and enduring constructions of the powerful empires of the Middle Ages, the architectural grandeur of which the moderns have not attempted to surpass.

5. Municipal Control of Public Water Supplies.

—The magnitude of the labors to be performed and the amount of capital required to be invested in the construction of a system of water supplies invariably brings into prominence the question, Shall the construction, operation, and control of these works be entrusted to private capital, or shall they be executed under the patronage of the municipal authorities and under the direction of a commission delegated by the people? The conclusion reached in a majority of the American cities has been that the works ought to be conducted as public enterprises. They have been believed to be so intimately connected with the public interests and welfare as to be peculiarly subjects for public promotion; and that, under the direction of a commission appointed by the people to study and comprehend all their needs, to consider, with the aid of expert advice, and to suggest plans, the works would be projected on such a liberal and comprehensive scale as would best fulfil the objects desired to be attained, and that the true interests of the people would not be subordinated to mere considerations of profit.

Further, that if the works when complete were operated under municipal care, their standard and effectiveness would more certainly be maintained; their extension into new territory might keep pace with and encourage the growth of the city; they might not, by excessive rates, be made to oppress important industries; their advantages might more surely be kept within the reach of the poorer classes; they might more economically be applied to the adornment of

the public buildings and grounds; and that they might, when judiciously planned, constructed, and managed, become a source of public revenue.

Nearly all the objects desirable to be attained in a public water supply have, however, been accomplished, in numerous instances that might be cited, under the auspices of private enterprise.

6. Value as an Investment.—The necessary capital honestly applied to the construction of an intelligently and judiciously planned effective public water supply has almost invariably proved, both directly and indirectly, a remunerative investment.

Many, though not all, of our American Water-supply Reports, show annual incomes from water-rates in excess of the combined annual operating expenses and interest on the capital expended. In addition to this cash return, there are in all cases benefits accruing to the public, usually exceeding in real value that of the more generally recognized money income.

7. Incidental Advantages.—The construction of water-works is almost sure to enhance the value of property along its lines, under its protection, and availing of its conveniences. There is, also, a perpetual reduction* in the

* In a recently adopted schedule of the National Board of Underwriters, there are *additions* to a minimum *standard rate* in a standard city, which is provided with good water supply, fire alarm, police, etc., as follows, termed deficiency charges:

Minimum standard rate of insurance of a standard building..	25 cents.
If no water supply	add 15 "
If only cisterns, or equivalent.....	" 10 "
If system is other than gravity.....	" 05 "
If no fire department.....	" 25 "
If no police organization.....	" 05 "
If no building law in force.....	" 05 "

The financial value of the enhanced fire risk, as deduced by the Board from an immense mass of statistics, and the additional premium charged on the

yearly rates of insurance. The substitution of soft water for hard water, as almost all waters are, results in a material reduction in the daily waste accompanying the preparation of foods, in laundry and cleansing operations, in the production of steam power, and in many of the processes employed in the useful arts.

There are many industries, the introduction of which are of value to a community, that cannot be prosecuted without the use of tolerably pure and soft water. To save the annual aggregate of labor required to convey water from wells into and to the upper floors of city tenements or residences, is a matter of no inconsiderable importance; but paramount to all these is the value of the sanitary results growing out of the maintenance of health, and the inducement to cleanliness of person and habitation, by the convenience of an abundance of water delivered constantly in the household, and the enhanced safety to human life and to property from destroying flames, accompanying a liberal distribution of public fire hydrants under adequate pressure throughout the populous districts.

most favorable buildings, is 60 per cent. without good water-works, and 40 per cent. if only fire cisterns are provided.

LIBRARY
UNIVERSITY OF
CALIFORNIA.

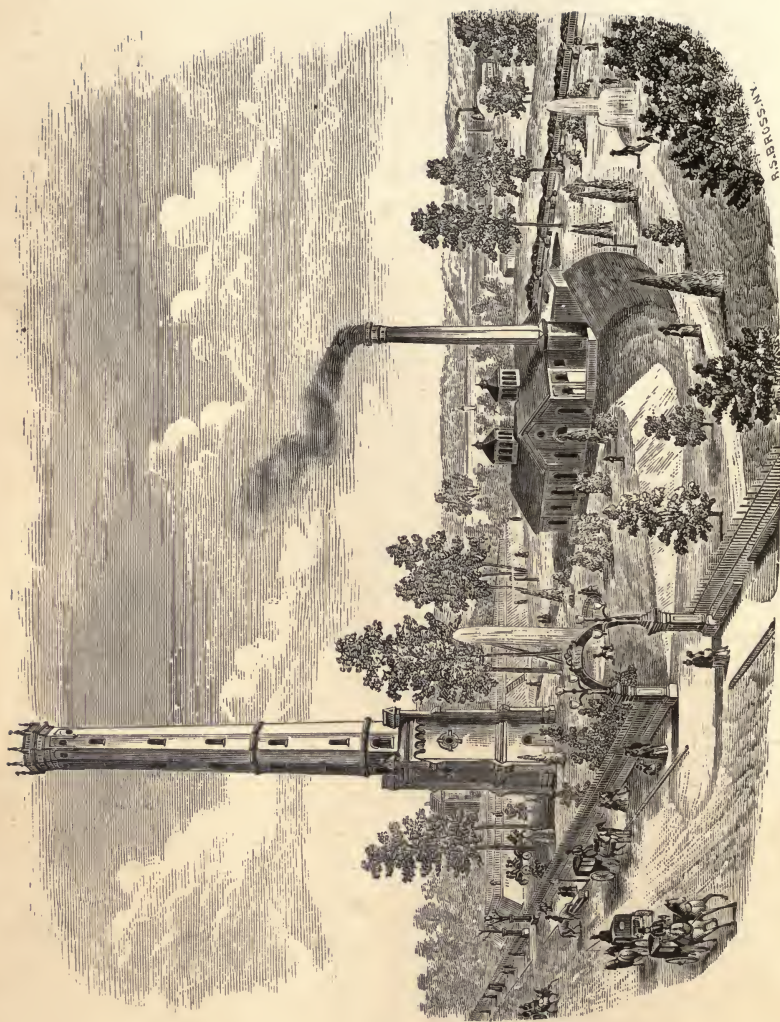

PUMPING STATION, TOLEDO.



CHAPTER II.

QUANTITY OF WATER REQUIRED.

8. Statistics of Water Supplied.—One of the first duties of a Commission to whom has been assigned the task of examining into and reporting upon a proposed supply of water for a community, is to determine not only what is a wholesome water, but what quantity of such wholesome water will be required, and adequate for its present and prospective uses.

In many cases, this problem is parallel with the determination of a product from two factors, one of which only is a known quantity. Often all factors must be assumed.

The total number of inhabitants, the total number of dwellings, and the total number of manufacturing and commercial firms can be obtained without great difficulty, and it can safely be assumed that eighty per cent. of all these within reach of a new and improved water supply will be among its patrons within a few years after the introduction of the new supply; but how much water will be required for actual use, or will be wasted, per person, per dwelling, or per firm, is always quite uncertain.

Rarely can any data worthy of confidence respecting these quantities be obtained. The practice, therefore, generally is, to obtain statistics from towns and cities already supplied, and to attempt to reduce these to some general average that will apply to the case in hand.

9. Census Statistics.—In a small portion of the water-supply reports there is given, in addition to the total quan-

tity of water supplied, the number of families supplied ; in other reports, the number of dwellings, or the number of fixtures of the several classes supplied, and occasionally the population supplied, or the total population of the municipality.

In the investigations for facts applicable to a new supply, when information must necessarily be culled from various water reports, it is often desirable to know the populations of the places from which the reports are received, their number of families, persons to a family, number of dwellings and persons to a dwelling, so as to be able to reduce their water-supply data to a uniform classification. We therefore present an abstract from the United States Census for the year 1870, giving such information respecting fifty prominent American cities :

TABLE No. 1.

POPULATION, FAMILIES, AND DWELLINGS IN FIFTY AMERICAN CITIES,
IN THE YEAR 1870.

CITIES.	SIZE.*	POPULATION.	FAMILIES.		DWELLINGS.	
			Number.	Persons to a family.	Number.	Persons to a dwelling
Albany, N. Y.....	20	69,422	14,105	4.92	8,748	7.94
Allegheny, Penn.....	23	53,180	10,147	5.24	8,347	6.37
Baltimore, Md.....	6	267,354	49,929	5.35	40,350	6.63
Boston, Mass.	7	250,526	48,188	5.20	29,623	8.46
Brooklyn, N. Y.....	3	396,099	80,066	4.95	45,834	8.64
Buffalo, N. Y.....	11	117,714	22,325	5.27	18,285	6.44
Cambridge, Mass.....	33	39,634	7,897	5.02	6,348	6.24
Charleston, S. C.....	26	48,956	9,098	5.38	6,861	7.14
Charlestown, Mass....	47	28,323	6,155	4.60	4,396	6.44
Chicago, Ill.....	5	298,977	59,497	5.03	44,620	6.70
Cincinnati, Ohio.....	8	216,239	42,937	5.04	24,550	8.81

* This column expresses the order of size as numbered from largest to smallest ; New York, the largest, being numbered 1.

POPULATION, ETC., IN FIFTY AMERICAN CITIES—(Continued).

CITIES.	SIZE.	POPULATION.	FAMILIES.		DWELLINGS.	
			Number.	Persons to a family.	Number.	Persons to a dwelling
Cleveland, Ohio	15	92,829	18,411	5.04	16,692	5.56
Columbus, Ohio	42	31,274	5,790	5.40	5,011	6.24
Dayton, Ohio	44	30,473	6,109	4.99	5,611	5.43
Detroit, Michigan	18	79,577	15,636	5.09	14,688	5.42
Fall River, Mass.	50	26,766	5,216	5.13	2,687	9.96
Hartford, Conn.	34	37,180	7,427	5.01	6,688	5.56
Indianapolis, Ind.	27	48,244	9,200	5.24	7,820	6.17
Jersey City, N. J.	17	82,546	16,687	4.95	9,867	8.37
Kansas City, Mo.	38	32,260	5,585	5.78	5,424	5.95
Lawrence, Mass.	45	28,921	5,287	5.47	3,443	8.40
Louisville, Ky.	14	100,753	19,177	5.25	14,670	6.87
Lowell, Mass.	31	40,928	7,649	5.35	6,362	6.43
Lynn, Mass.	49	28,233	6,100	4.63	4,625	6.10
Memphis, Tenn.	32	40,226	7,824	5.14	6,408	6.28
Milwaukee, Wis.	19	71,440	14,226	5.02	13,048	5.48
Mobile, Ala.	39	32,034	6,301	5.08	5,738	5.58
Newark, N. J.	13	105,059	21,631	4.86	14,350	7.32
New Haven, Conn.	25	50,840	10,482	4.85	8,100	6.28
New Orleans, La.	9	191,418	39,137	4.89	33,656	5.69
New York, N. Y.	1	942,292	185,789	5.07	64,044	14.72
Paterson, N. J.	37	33,579	7,048	4.76	4,653	7.22
Philadelphia, Pa.	2	674,022	127,746	5.28	112,366	6.01
Pittsburg, Pa.	16	86,076	16,182	5.32	14,224	6.05
Portland, Me.	41	31,413	6,632	4.74	4,836	6.50
Providence, R. I.	21	68,904	14,775	4.66	9,227	7.46
Reading, Pa.	36	33,930	6,932	4.89	6,294	5.39
Richmond, Va.	24	51,038	9,792	5.21	8,033	6.35
Rochester, N. Y.	22	62,386	12,213	5.11	11,649	5.36
San Francisco, Cal.	10	149,473	30,553	4.89	25,905	5.77
Savannah, Ga.	48	28,235	5,013	5.63	4,561	6.19
Scranton, Pa.	35	35,092	6,642	5.28	5,646	6.21
St. Louis, Mo.	4	310,864	59,431	5.23	39,675	7.84
Syracuse, N. Y.	29	43,051	8,677	4.96	7,088	6.07
Toledo, Ohio.	40	31,584	6,457	4.89	6,069	5.20
Troy, N. Y.	28	46,465	9,302	5.00	5,893	7.88
Utica, N. Y.	46	28,804	5,793	4.97	4,799	6.00
Washington, D. C.	12	109,199	21,343	5.12	19,545	5.59
Wilmington, Del.	43	30,841	5,808	5.31	5,398	5.71
Worcester, Mass.	30	41,105	8,658	4.74	4,922	8.35

10. Approximate Consumption of Water.—In American cities, having well arranged and maintained systems of water supply, and furnishing good wholesome water for domestic use, and clear soft water adapted to the uses of the arts and for mechanical purposes, the average consumption is found to be approximately as follows, in United States gallons :

(a.) For ordinary domestic use, not including hose use, 20 gallons per capita per day.

(b.) For private stables, including carriage washing, when reckoned on the basis of inhabitants, 3 gallons per capita per day.

(c.) For commercial and manufacturing purposes, 5 to 15 gallons per capita per day.

(d.) For fountains, drinking and ornamental, 3 to 10 gallons per capita per day.

(e.) For fire purposes, $\frac{1}{10}$ gallon per capita per day.

(f.) For private hose, sprinkling streets and yards, 10 gallons per capita per day, during the four driest months of the year.

(g.) Waste to prevent freezing of water in service-pipes and house-fixtures, in Northern cities, 10 gallons per capita per day, during the three coldest months of the year.

(h.) Waste by leakage of fixtures and pipes, and use for flushing purposes, from 5 gallons per capita per day upward.

The above estimates are on the basis of the total populations of the municipalities.

There will be variations from the above approximate general average, with increased or decreased consumption for each individual town or city, according to its social and business peculiarities.

The domestic use is greatest in the towns and cities, and in the portions of the towns and cities having the greatest wealth and refinement, where water is appreciated as a luxury as well as a necessity, and this is true of the yard sprinkling and ornamental fountain use, and the private stable use.

The greatest drinking-fountain use, and fire use, and general waste, will ordinarily be in the most densely-populated portions, while the commercial and manufacturing use will be in excess where the steam-engines are most numerous, where the hydraulic elevators and motors are, on the steamer docks, and where the brewing and chemical arts are practiced.

The ratio of length of piping to the population is greater in wealthy suburban towns than in commercial and manufacturing towns.

Some of these peculiarities are brought out in a following table of the quantity of water supplied and of piping in several cities, which is based upon the census table heretofore given and upon various water-works reports for the year 1870.

The general introduction of public water-works, on the constant-supply system, with liberal pressures in the mains and house-services, throughout the American towns and cities, has encouraged its liberal use in the households, so that it is believed that the legitimate and economical *domestic* use of water is of greater average in the American cities than in the cities of any other country, at the present time, and its general use is steadily increasing.

11. Water Supplied to Ancient Cities.—The supplies to ancient Jerusalem, imperial Rome, Byzantium, and Alexandria, were formerly equal to three hundred gallons per individual daily; and, later, the supplies to Nismes,

Metz, and Lyons, in France, and Lisbon, Segovia, and Seville, in Spain, were most liberal, but a small proportion only of the water supplied from these magnificent public works was applied to domestic use, except in the palaces of those attached to the royal courts.

12. Water Supplied to European Cities.—In the year 1870, the average daily supply to some of the leading European cities was approximately as follows :

CITIES.	IMP. GALLONS.
London, England	29
Manchester, "	24
Sheffield, "	29
Liverpool, "	27
Leeds, "	23
Edinburgh, Scotland.....	30
Glasgow, "	40
Paris, France	30
Marseilles, "	40
Genoa, Italy.....	30
Geneva, Switzerland.....	16
Madrid, Spain.....	16
Berlin, Prussia.....	18

In the year 1866, public water supplies * were, in volume, as follows, in the cities named :

CITIES.	POPULATION.	SUPPLY PER CAPITA.
Hamburg, Prussia	200,000	34 gals.
Altona, "	52,000	20 "
Tours, France	42,000	22 "
Angers, "	53,000	11.5 "
Toulouse, "	100,000	13.5 "
Nantes, "	112,000	13.6 "
Lyons, "	300,000	22 "

* Vide Kirkwood's "Filtration of River Waters." Van Nostrand, N. Y., 1869.

Prof. Rankine gives,* as a fair estimate of the real daily demand for water, per inhabitant, amongst inhabitants of different habits as to the quantity of water they consume, the following, based upon British water supply and consumption :

RANKINE'S ESTIMATE FOR ENGLAND.

	IMP. GALLONS PER DAY.		
	Least.	Average.	Greatest.
Used for domestic purposes	7	10	15
Washing streets, extinguishing fires, supplying fountains, etc.	3	3	3
Trade and manufactures	7	7	7
Waste under careful regulations, say	2	2	2½
Total demand	19	22	27½

13. Water Supplied to American Cities.—The limited use of water for domestic purposes in many of the European cities during the last half century, led the engineers who constructed the pioneer water-works of some of the American States to believe that 30 gallons of water per capita daily would be an ample allowance here; and in their day there was scarce a precedent to lead them to anticipate the present large consumption of water for lawn and street sprinkling by hand-hose, or for waste to prevent freezing in our Northern cities.

The following tables will show that this early estimated demand for water has been doubled, trebled, and in some instances even quadrupled; and this considerable excess, to which there are few exceptions, has been the cause of much annoyance and anxiety.

* "Civil Engineering," London, 1872, p. 731.

In the year 1870, the average daily supply to some of the American cities was as follows, in United States gallons :

TABLE NO. 2.

WATER SUPPLIED AND PIPING IN SEVERAL CITIES, IN THE YEAR 1870.

CITIES.	POPULATION IN 1870.	SUPPLY PER PERSON, DAILY AVERAGE.	SUPPLY PER FAMILY, DAILY AVERAGE.	SUPPLY PER DWELLING, DAILY AVERAGE.	TOTAL DAILY SUPPLY, AVERAGE.	TOTAL MILES OF PIPE MAINS.	MILES OF PIPE PER 1,000 INHABITANTS.
		<i>Gallons.</i>	<i>Gallons.</i>	<i>Gallons.</i>	<i>Gallons.</i>	<i>Miles.</i>	<i>Miles.</i>
Baltimore. . . .	267,354	52.81	282.53	350.13	14,122,032	214	0.80
Boston	250,526	60.15	312.78	508.87	15,070,400	194	0.78
Brooklyn	396,099	47.16	233.44	407.46	18,682,219	258	0.65
Buffalo	117,714	58.08	306.08	374.04	6,838,303	56	0.48
Cambridge. . . .	39,634	43.90	220.38	273.94	1,739,869	60	1.64
Charlestown. . .	28,323	43.90	201.94	282.72	1,243,380	25	0.90
Chicago	298,977	62.32	313.47	417.54	18,633,000	240	0.81
Cincinnati . . .	216,239	40.00	201.60	352.40	10,812,609	132	0.61
Cleveland. . . .	92,829	33.24	167.53	184.81	3,085,559	50	0.54
Detroit	79,577	64.24	236.98	348.18	5,112,493	129	1.61
Hartford. . . .	37,180	65.81	329.71	365.90	2,447,000	48	1.30
Jersey City. . .	82,546	83.66	414.12	700.23	6,906,056	70	0.85
Louisville. . . .	100,753	28.95	151.99	198.89	2,817,300	58	0.58
Montreal, Can.	117,500	49.00	5,720,306	96	0.81
Newark. . . .	105,059	20.20	98.17	147.86	2,121,842	52	0.50
New Haven. . .	50,840	59.00	286.15	370.52	3,000,000	53	1.04
New Orleans. .	191,418	30.19	147.63	171.78	5,779,317	58	0.30
New York . . .	942,292	90.20	457.31	1,327.74	85,000,000	346	0.37
Philadelphia . .	674,022	55.11	290.98	331.21	37,145,385	488	0.71
Salem.	24,117	41.46	1,000,000	35	1.04
St. Louis	310,864	35.38	185.04	277.38	11,000,000	105	0.34
Washington. . .	109,199	127.00	650.24	709.93	13,868,273	102	0.93
Worcester. . . .	41,105	48.65	230.60	406.23	2,000,000	45	1.09

25 114.71
49.58

The average quantity of water supplied to some of the same cities in 1874 is indicated in the following table, showing also the extensions of the pipe systems, and the increase in the average daily consumption of water per capita, from year to year :

TABLE No. 3.
WATER SUPPLIED IN YEARS 1870 AND 1874.

CITIES.	AVERAGE DAILY SUPPLY PER CAPITA.		TOTAL AVERAGE DAILY SUPPLY.		TOTAL MILES OF PIPES.	
	1870.	1874.	1870.	1874.	1870.	1874.
Boston	60	60	15,070,400	18,000,000	194	262
Brooklyn	47	58	18,682,219	24,772,467	258	323
Buffalo	58	60	6,838,303	8,509,481	56	87
Cambridge	44	54	1,739,869	2,300,000	60	76
Charlestown	44	62	1,243,380	7,643,017	25	132
Chicago	64	84	18,633,000	38,090,952	240	386
Cincinnati	40	45	10,812,609	13,600,596	132	156
Cleveland	32	45	3,085,559	5,625,150	50	81
Detroit	64	87	5,112,493	9,013,350	129	177
Jersey City	84	86	6,906,056	10,421,001	70	111
Louisville	29	24	2,817,300	3,598,730	58	91
Newark	20	38	2,121,842	4,732,718	52	112
Philadelphia	55	58	37,145,385	42,111,730	488	625
Salem	41	55	1,000,000	1,380,000	35	40
Washington	127	138	13,868,273	18,000,000	102	141
Worcester	49	80	2,000,000	3,000,000	45	63
Montreal	49	66	5,720,306	8,395,810	96	114

1790 1800
53 55

14. The Use of Water Steadily Increasing.—The legitimate use of water is steadily being popularized, calling for an increased average in the amount of household apparatus, increased facilities for garden irrigation and *jets d'eau*, increased street areas moistened in dusty seasons, and increased appliances for its mechanical use; from all which follows increased waste of water.

15. Increase in Various Cities.—The following table is introduced to show the average daily supply in various cities through a succession of years:

TABLE No. 4.

AVERAGE GALLONS WATER SUPPLIED TO EACH INHABITANT DAILY IN

YEAR.	Boston.	Buffalo.	Brooklyn.	Cleveland.	Cincinnati.	Chicago.	Detroit.	Jersey City.	Louisville.	Montreal.	New York.	Philadelphia.	Washington.
1856.....	—	—	—	—	—	—	55	—	—	—	—	—	—
1857.....	—	—	—	8	—	—	46	—	—	—	—	—	—
1858.....	—	—	—	8	—	33	46	75	—	—	—	—	—
1859.....	—	—	—	11	—	40	48	—	—	—	—	—	—
1860.....	—	—	—	14	—	43	52	77	—	—	—	—	—
1861.....	—	—	—	16	—	43	53	—	9	—	—	—	—
1862.....	—	—	17	19	39	44	58	—	14	—	—	—	—
1863.....	—	—	22	21	—	43	58	—	12	—	—	—	—
1864.....	—	—	26	22	—	41	57	—	14	—	62	—	—
1865.....	—	—	29	22	—	42	55	77	17	—	—	—	—
1866.....	55	—	33	22	—	43	60	—	17	—	—	—	—
1867.....	59	—	36	24	—	50	64	—	15	—	62	46	—
1868.....	62	—	43	25	—	58	67	—	16	—	68	51	—
1869.....	62	—	46	27	—	62	61	—	18	—	84	51	—
1870.....	60	58	47	33	40	63	64	84	29	49	90	55	127
1871.....	54	51	46	36	—	73	73	—	19	55	85	55	130
1872.....	55	61	50	40	60	75	83	99	22	55	88	54	134
1873.....	58	60	55	43	—	75	90	—	22	60	104	56	138
1874.....	60	60	58	45	45	84	87	86	24	66	—	58	138

16. Relation of Supply per Capita to Total Population.—In the larger cities there are generally the greatest variety of purposes for which water is required, and consequently a greater average daily consumption per capita. Exceptions to this general rule may be found in a few suburban towns largely engaged in the growth of garden truck, and plants, and shrubs for the urban markets, in which there is a large demand for water for purposes of irrigation.

In the New England towns and cities the average daily consumption and waste of water according to population is approximately as follows :

Places of 10,000 population, 35 to 45 gallons per capita.

“	“	20,000	“	40 to 50	“	“	“
“	“	30,000	“	45 to 65	“	“	“
“	“	50,000	“	55 to 75	“	“	“

Places of 75,000 population and upward, 60 to 100 gallons per capita.

17. Monthly and Hourly Variations in the Draught.

—The data heretofore given relating to the daily average consumption of water have referred to annual quantities reduced to their daily average. The daily draught is not, however, uniform throughout the year, but at times is greatly in excess of the average for the year, and at other times falls below.

It may be twenty to thirty per cent. in excess during several consecutive weeks, fifty per cent. during several consecutive days, and not infrequently one hundred per cent. in excess during several consecutive hours, independently of the occasional heavy drafts for fires. Diagrams of this daily consumption of water in the cities usually show two principal maxima and two principal minima. The earliest maximum in the year occurs, in the Eastern and Middle States, about the time the frost is deepest in the ground and the weather is coldest, that is, between the middle of January and the first of March, and in New England cities this period sometimes gives the maximum of the year. The second maximum occurs usually during the hottest and driest portion of the year, or between the middle of July and the first of September. The two principal minima occur in the spring and autumn, about midway between the maxima. Between these four periods the profile shows irregular wavy lines, and a profile diagram continued for a series of years shows a very jagged line.

To illustrate the irregular consumption of water, we

FIG. 1.

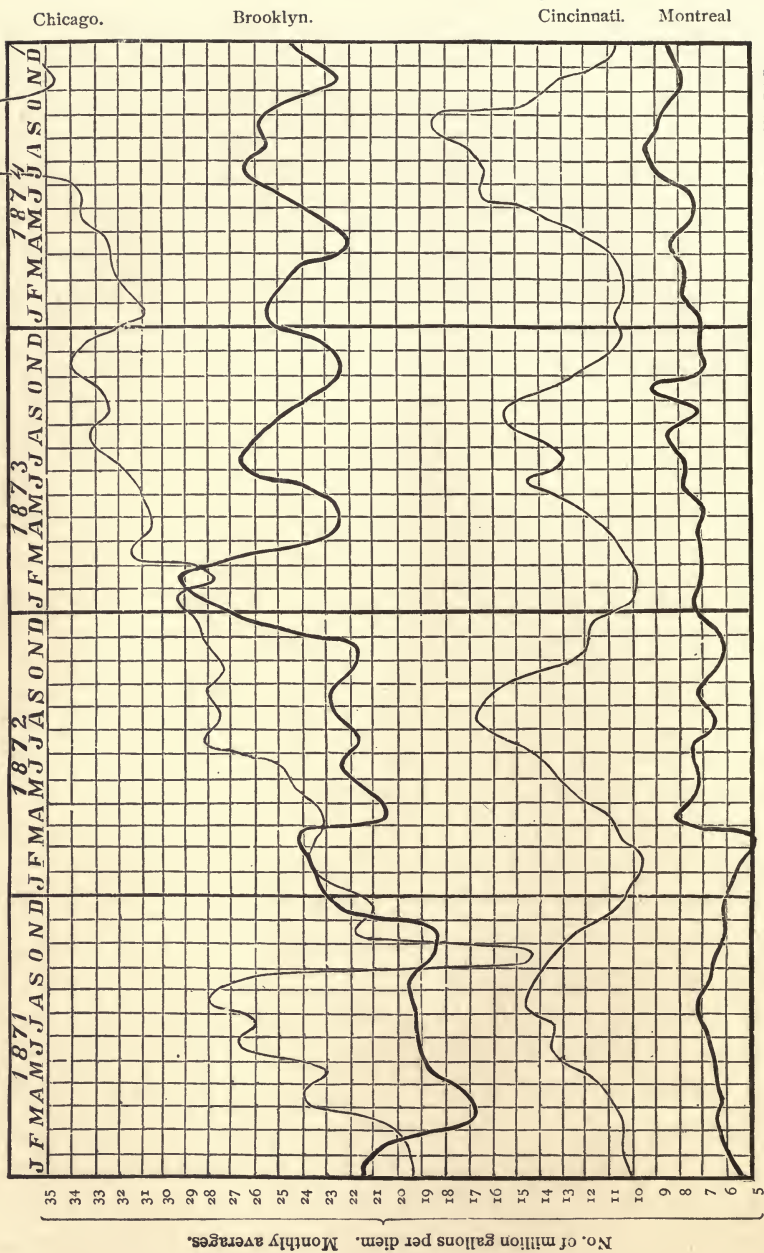

MONTHLY DIAGRAM OF WATER SUPPLIED TO CHICAGO, BROOKLYN, CINCINNATI, AND MONTREAL, IN YEARS 1871, 1872, 1873, AND 1874.

have prepared the diagrams, Fig. 1, of the operations of the pumps at Chicago, Brooklyn, Cincinnati, and Montreal, during the years 1871, 1872, 1873, and 1874.

18. Ratio of Monthly Consumption.—The variations in draught, as by monthly classification, in several prominent cities, in the year 1874, have been reduced to ratios of mean monthly draughts for convenience of comparison, and are here presented; unity representing the mean monthly draught for the year:

TABLE NO. 3.

RATIOS OF MONTHLY CONSUMPTION OF WATER IN 1874.

CITIES.	Jan.	Feb.	March.	April.	May.	June.	July.	Aug.	Sept.	Oct.	Nov.	Dec.
Brooklyn....	1.029	1.132	.971	.892	.941	1.008	1.069	1.034	1.044	.987	.919	.974
Buffalo. . . .	1.008	1.007	.960	.941	.983	.963	.996	1.020	1.044	1.011	1.040	1.000
Cleveland... .	.883	.901	.850	.871	.992	1.180	1.181	1.206	1.058	1.001	.942	.915
Detroit856	.807	.905	.844	1.029	1.065	1.051	1.167	1.171	1.115	.987	1.003
Philadelphia. .	.850	.844	.834	.898	1.056	1.199	1.289	1.145	1.091	.990	.952	.853
Chicago862	.844	.904	.904	.942	.942	1.171	1.193	1.162	1.039	.966	1.029
Cincinnati... .	.792	.762	.778	.856	1.011	1.217	1.207	1.257	1.302	1.058	.960	.799
Louisville. . .	.842	.819	.848	.841	.960	1.192	1.207	1.223	1.202	1.138	.940	.876
Montreal....	.864	.959	.943	1.025	.916	.907	1.101	1.151	1.096	1.043	.971	1.023
Mean... .	.887	.897	.888	.897	.960	1.075	1.144	1.155	1.130	1.042	.964	.941

There is also a very perceptible daily variation in each week, and hourly variation in each day, in the domestic consumption of water.

The Brooklyn diagram shows that the average draught in the month of maximum consumption was in 1872, fifteen per cent. in excess of the average annual draught; in 1873, seventeen per cent. in excess; in 1874, thirteen per cent. in excess.

A Boston Highlands direct pumping diagram lying before the writer shows that the average draught at nine o'clock in the forenoon was thirty-seven per cent. in excess

of the average draught for the three months, and that at eight o'clock A.M. on the Mondays the draught was sixty per cent. in excess of the average hourly draught for the three months.

The maximum hourly draught indicated by the two diagrams taken together is nearly seventy-five per cent. in excess of the average throughout the year.

19. Illustrations of Varying Consumption.—In illustration, we will assume a case of a suburban town requiring, say, an average daily consumption for the year of 1,000,000 United States gallons of water, and compute the maximum rate of draught on the bases shown by the above-named diagrams, thus:

	GALLONS PER DAY.	GALLONS PER MIN.	CUBIC FEET PER MIN.
Average draught per year	1,000,000	694.4	92.8
Add 17 per cent. for max. monthly average draught, making	1,017,000	706.2	93.1
Add to the last quantity 10 per cent. for the max. weekly average draught, making	1,027,170	713.2	95.3
Add to the last quantity 37 per cent. for the max. hourly average draught, making	1,407,222	972.2	129.9
Add to the last quantity 23 per cent. for the max. hourly av. draught on Mondays, making	1,730,883	1,202.0	160.7

The experience of nearly every water-supply shows that the maximum draught, aside from fire-service, is at times more than double the average draught.

20. Reserve for Fire Extinguishment.—In addition to the above, there should be an ample reserve of water for fire service, and extra conduit and distribution capacity for its delivery. There is a possibility of two or three fires being in progress at the same time, in even the smaller cities, requiring at least twelve hydrant streams, or say 300 cubic feet of water per minute, for each fire.

LIBRARY
UNIVERSITY OF
CALIFORNIA.

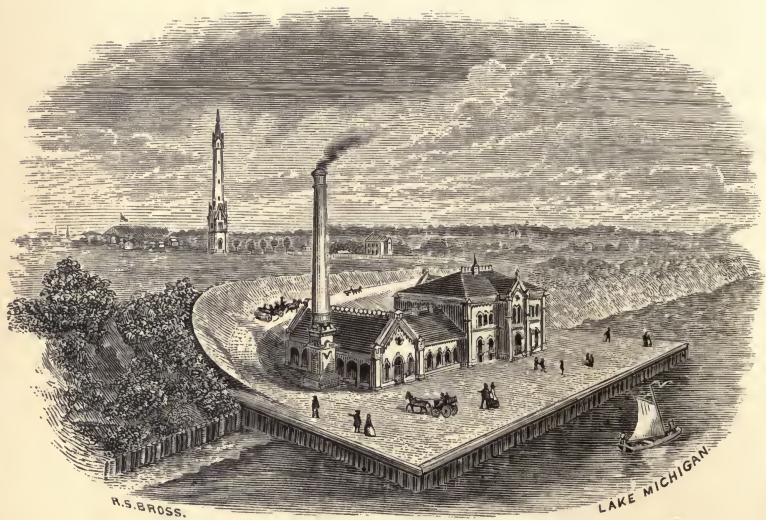

PUMPING STATION, MILWAUKEE.



CHAPTER III.

RAINFALL.

21. The Vapory Elements.—The elements of water fill the ethereal blue above and the earth crust beneath. They, with unceasing activity, permeate the air, the rocks, the sand, the fruits we eat, and the muscles that aid our motion.

Since first "there went up a mist from the earth," the struggle between the ethereal elements and earth's internal fire, between the intense cold of space and direct and radiated heat enveloping the face of the earth, has gone on unceasingly.

22. The Liquid and Gaseous Successions.—If we hold a drop of water in the clear sunshine and watch it intently, soon it is gone and we could not see it depart; if we expose a dish of water to the heat of fire, silently it disappears, and we know not how it gathered in its activity; if we leave a tank of water uncovered to the sun and wind, it gradually disappears, and is replenished by many showers of summer, still it departs and is replenished by snows of winter. Under certain extreme conditions it may never be full, it may never be exhausted, the rising vapor may equal the falling liquid, as where "the rivers flow into the sea, yet the sea is not full."

23. The Source of Showers.—Physical laws whose origin we cannot comprehend but whose steady effects we observe, lift from the saline ocean, the fouled river, the moist earth, a stream of vapor broad as the circuit of the globe,

but their solid impurities remain, and the flow goes up with ethereal clearness.

From hence are the sources of water supply replenished. From hence comes the showers upon the face of the earth.

24. General Rainfall.—But there is irregularity in the physical features of the earth, and unevenness in the temperature about it, and the showers are not called down alike upon all its surface. Upon the temperate zone in America enough water falls in the form of rain and snow to cover the surface of the ground to an average depth of about 40 inches, in the frigid zone a lesser quantity, and in the torrid zone full 90 inches, and in certain localities to depths of 100 and 150, and at times to even 200 inches.

We recognize in the rain an ultimate source of water supply, but the immediate sources of local domestic water supply are, shallow or deep *wells, springs, lakes, and rivers*. The amplitude of their supply is dependent upon the *available amount of the rainfall* that replenishes them. In cases of large rivers, and lakes like the American inland seas, there can be no question as to their answering all demands, as respects quantity, that can be made upon them, but often upon watersheds of limited extent, margins of doubt demand special investigations of their volumes of rainfall, and the portions of them that can be utilized.

25. Review of Rainfall Statistics.—Looking broadly over some of the principal river valleys of the United States we find their average annual rainfalls to be approximately as follows: Penobscot, 45 inches; Merrimack, 43; Connecticut, 44; Hudson, 39; Susquehanna, 37; Roanoke, 40; Savannah, 48; Appalachian, 48; Mobile, 60; Mississippi, 46; Rio Grande, 19; Arizonian Colorado, 12; Sacramento, 28; and Columbia, 33 inches; but the amount of rainfall at the various points from source to mouth of

each river is by no means uniform ; as, for instance, upon the Susquehanna it ranges from 26 to 44 inches ; on the Rio Grande, from 8 to 37 inches ; and on the Columbia, from 12 to 86 inches.

26. Climatic Effects.—The North American Continent presents, in consequence of its varied features and reach from near extreme torrid to extreme polar regions, almost all the special rainfall characteristics to be found upon the face of the globe ; and even the United States of America includes within its limits the most varied classes of climatological and meteorological effects, in consequence of its range of elevation, from the Florida Keys to the Rocky Mountain summits, and its range of humidity from the sage-bush plains between the Sierras and Wahsatch Mountains, and the moist atmosphere of the lower Mississippi valley, and from the rainless Yuma and Gila deserts of southern California to the rainy slopes of north-western California and of Oregon, where almost daily showers maintain eternal verdure.

27. Sections of Maximum Rainfall.—The maximum recorded rainfall, an annual mean of 86 inches, occurs in the region bordering upon the mouth of the Columbia River and Puget Sound. A narrow belt of excessive humidity extends along the Pacific coast from Vancouver's Island southerly past the borders of Washington Territory, Oregon and California, to latitude 40°.

Next in order of humidity is the region bordering upon the Delta of the Mississippi River and the *embouchure* of the Mobile, whose annual mean of rain reaches 64 inches.

Next in order is a section in the heart of Florida of about one-half the breadth of the State, whose mean annual rain reaches 60 inches.

28. Western Rain System.—The great northerly ocean current of the Pacific moves up past the coast of

China and the Aleutian Islands and impinges upon the North American shore, then sweeps down along the coast of Washington Territory, Oregon and California ; and from its saturated atmosphere, flowing up their bold western slopes, is drawn the excessive aqueous precipitations that water these regions.

Their moist winds temper the climate and their condensed vapors irrigate the land, so that the southerly portion of the favored region referred to is often termed the garden of America.

Fig. 2 is a profile, showing a general contour across the North American Continent, along the thirty-ninth parallel of latitude.

FIG. 2.

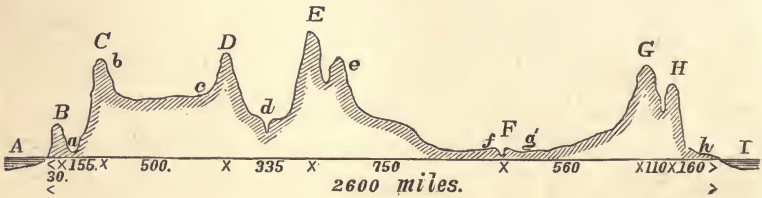

ELEVATION.
feet.

A. Pacific Ocean.	a. Sacramento City.....	82
B. Coast Range.	b. Carson City.....	4,629
C. Sierra Nevada.	c. Salt Lake Region.....	4,382
D. Wahsatch Mountains.	d. Colorado River.....	—
E. Rocky Mountains.	e. Colorado City.....	6,000
F. Mississippi River.	f. St. Louis.....	481
G. Alleghany Mountains.	g. Cincinnati.....	582
H. Blue Ridge.	h. Washington.....	70
I. Atlantic Ocean.		

The California coast range and the western slope of the Sierra Nevadas are the condensers that gather from the prevailing westerly ocean breezes their moisture. From thence the winds pass easterly over the Sierra summit almost entirely deprived of moisture, and yield but rarely any rain upon the broad interior basin stretching between the bases of the Sierra and Wahsatch Mountains. Upon the

arid plains of this region, above the Gulf of California, whose average annual rainfall reaches scarce 4 inches, the winds roll down like a thirsty sponge.

Further to the east, the western slopes of the Wahsatch and Rocky Mountains lift up and condense again the western winds, and gather in their storms of rain and snow. In the lesser valley between these mountains, 12 to 20 inches of rain falls annually, and the tributaries of the Colorado River gathers its scanty surplus of waters and leads them from thence around the southerly end of the Wahsatch Mountains past the Yuma Desert to the Gulf.

Over the summit of the Rocky Mountains onward moves the westerly wind, again deprived of its vapor, and down it rolls with thirsty swoop upon the Great American Desert, skirting the eastern base of the mountains. Farther on, it is again charged with moisture by the saturated wind-eddy from the Caribbean Sea and Gulf of Mexico.

The great Pacific currents of water and wind, and the extended ridges and furrows of the westerly half of our Continent lend their combined influence, in a marked manner, to develop its special local and its peculiar general climatic and meteorological systems.

29. Central Rain System.—A second system of anti-trade winds bears the saturated atmosphere of the Gulf of Mexico up along the great plain of the Mississippi. Its moisture is precipitated in greatest abundance about the delta, and more sparingly in the more elevated valleys of the Red and Arkansas rivers upon the left, and the Tennessee and Ohio rivers upon the right. Its influence is perceptible along the plain from the Gulf to the southern border of Lake Michigan, and easterly along the lower lakes and across New England, where the chills of the Arctic polar current sweeping through the Gulf of St. Lawrence

and down the Nova Scotia coast into Massachusetts Bay, throws down abundantly its remaining moisture.

30. Eastern Coast System.—A third system envelops Florida, Georgia, and the eastern Carolinas, especially in summer, with an abundance of rain.

A fourth subordinate system shows the contending thermic and electric influences of the warm and moist atmosphere from the Gulf Stream, flowing northerly past, and of the cooler atmosphere from the polar current flowing southerly upon the New England coast, where an abundant rain is distributed more evenly throughout the seasons than elsewhere upon the Continent.

31. Influence of Elevation upon Precipitation.—The influence of elevation above the sea-level is far less active in producing excessive rain upon our ^{American} mountain ranges and high river sources than upon other continents and some of the mountainous islands, being quite subordinate to general wind currents.

Upon the mountainous island of Guadaloupe, in latitude 16°, for instance, a rainfall of 292 inches per annum at an elevation of 4500 feet is recorded.

Upon the Western Ghauts of Bombay, at an elevation of 4,500 feet, an average rainfall for fifteen years is given as 254 inches.

On the southerly slope of the Himalayas, northerly of the Bay of Bengal, at an elevation of 4,500 feet, the rainfall of 1851 was 610 inches. These localities all face prevailing saturated wind currents.

32. River-basin Rains.—A study of some of our principal river valleys independently, reveals the fact that their rainfall gradually decreases from their outlets to their more elevated sources.

In illustration of this fact, we present the following river-valley statistics relating to the principal basins along the Atlantic, Gulf, and Pacific coasts.

TABLE No. 6.

MEAN RAINFALL ALONG RIVER COURSES, SHOWING THE DECREASE IN PRECIPITATION OF RAIN AND MELTED SNOW FROM THE RIVER MOUTHS, UPWARD.

ST. JOHN'S RIVER.

NAME OF STATION.	SUMMER.	WINTER.	YEAR.	DISTANCE FROM MOUTH.	
	<i>Inches.</i>	<i>Inches.</i>	<i>Inches.</i>	<i>Miles (approximate).</i>	
St. Johns	10	14	51	5	Distances from the Atlantic Ocean. Average rain, 43 inches.
Fort Kent.....	12	10	36	230	

MERRIMACK RIVER.

Newburyport.....	12	12	41	5	Distances from the Atlantic Ocean. Average rain, 43 inches.
Lawrence.....	19	11	45	25	
Manchester.....	11	11	45	60	
Concord.....	11	9	41	78	

CONNECTICUT RIVER.

Saybrook.....	13	13	49	4	Distances from Long Island Sound. Average rain, 44 inches.
Middletown.....	13	12	46	25	
Hartford.....	10	11	44	40	
Hanover.....	11	9	40	180	
St. Johnsbury.....	11	8	36	235	

HUDSON RIVER.

New York City.....	12	10	44	8	Distances from the Atlantic Ocean. Average rain, 39 inches.
Poughkeepsie.....	12	9	40	75	
Hudson.....	10	7	35	115	
Albany.....	9	8	36	145	

SUSQUEHANNA RIVER.

Havre de Grace....	13	10	44	5	Distances from Chesapeake Bay. Average rain, 37 inches.
Harrisburg.....	12	8	49	70	
Lewisburg.....	11	8	39	120	
Williamsport.....	10	7	39	140	
Owego.....	8	6	34	200	
Elmira.....	7	4	26	200	

MEAN RAINFALL ALONG RIVER COURSES—(Continued).

MISSISSIPPI RIVER.

NAME OF STATION.	SUMMER.	WINTER.	YEAR.	DISTANCE FROM MOUTH.	
	<i>Inches.</i>	<i>Inches.</i>	<i>Inches.</i>	<i>Miles (approximate).</i>	
Delta.....	20	18	60	10	} Distances from the Gulf of Mexico. Average rain, 46 inches.
New Orleans.....	20	16	60	95	
Baton Rouge.....	18	15	60	190	
Junc. of Red River..	14	16	56	240	
Vicksburg.....	11	15	55	350	
Memphis.....	8	15	42	560	
Cairo.....	11	12	42	700	
St. Louis.....	13	8	42	850	
Dubuque.....	14	5	38	1100	
Lacrosse.....	11	3	30	1200	
St. Paul's.....	11	3	25	1500	

RIO GRANDE.

Brownsville.....	8	6	37	30	} Distances from the Gulf of Mexico. Average rain, 19 inches.
Junc. Pecos River..	5	3	18	400	
El Paso.....	4	2	12	800	
Albuquerque.....	3	2	8	1050	

COLUMBIA RIVER.

Astoria.....	4	44	86	5	} Distances from the Pacific Ocean. Average rain, 33 inches.
Walla-Walla.....	2	5	20	275	
Boise City.....	2	7	13	600	
Fort Hall.....	1	6	12	850	

Reference to the above, from among the principal river valleys, is sufficient to show that the oft-made statement, that "rain falls most abundantly on the high land," is applicable, in the United States, to subordinate watersheds only, and in rare instances.

33. Grouped Rainfall Statistics.—The following table gives the minimum, maximum, and mean rainfalls, according to the most extended series of observations, at various stations in the United States. They are grouped by territorial divisions, having uniformity of meteorological characteristics.

FIG. 3.

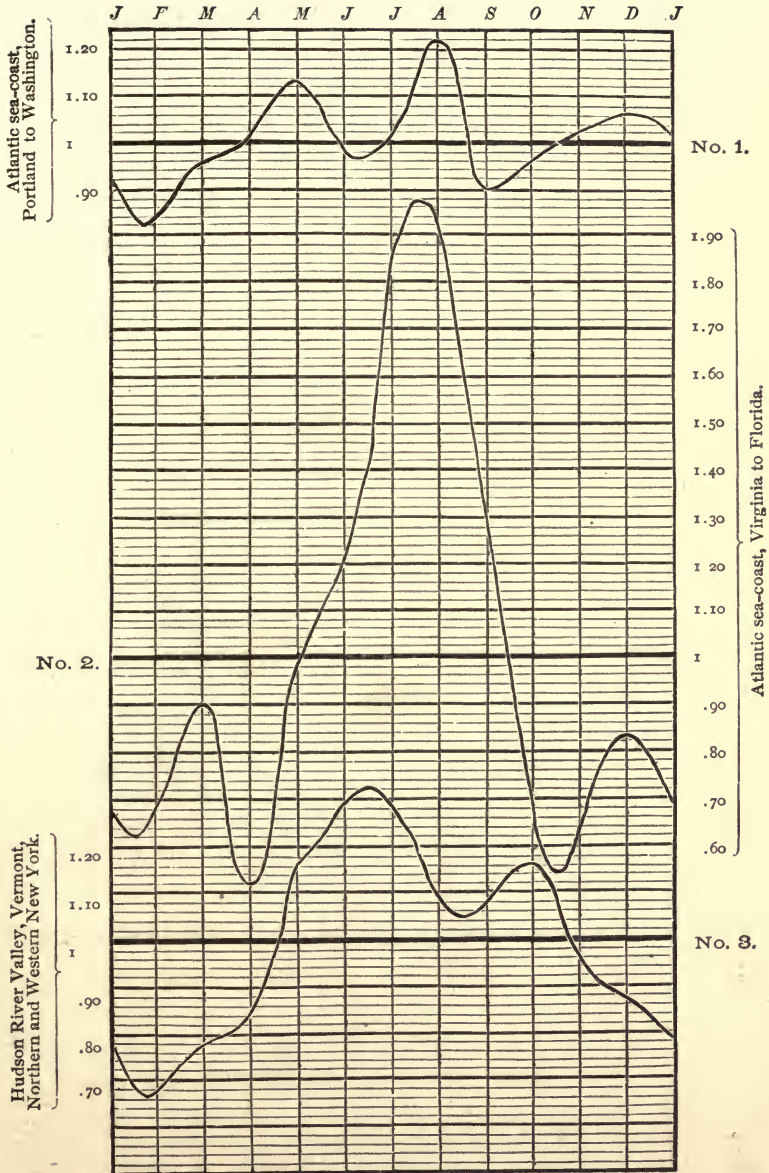

CURVES OF ANNUAL FLUCTUATIONS IN RAINFALL.

34. Monthly Fluctuations in Rainfall.—Our generalizations thus far have referred to the mean annual rainfall over large sections. There is a large range of fluctuation in the average amount of precipitation through the different seasons of the year, in different sections of the United States. It will be of interest to follow out this phase of the question in diagrams 3 and 4, in which type curves* of monthly means are drawn about a line of annual mean covering a series of years, in no case less than fifteen.

The letters J, F, M, &c., at the heads of the diagrams, are the initials of the months. The heavy horizontal lines represent means for the year, which are taken as unity. Their true values may be found at the foot of their respective groups in the above table. About this line of annual mean is drawn by free-hand the type curve of mean rainfall through the successive months, showing for each month its percentage of the annual mean.

Each type curve relates to a section of country having uniform characteristics in its annual distribution of rain.

Curve No. 1, for Group No. 1, includes the section of country bordering upon the Atlantic sea-coast from Portland to Washington. The average fluctuation of the year in this section is forty per cent. Its maximum rainfall occurs oftenest in August, and its minimum oftenest in January or February.

Curve No. 2, for Group No. 2, includes the Atlantic coast border from Virginia to Florida. The average fluctuation of the year is one hundred and ninety-eight per cent. Its maximum rainfall occurs oftenest about the first of August, and nearly equal minima in April and October.

* Reduced from a diagram by Chas. Schott, C. E., Smithsonian Contribution, Vol. XVIII, p. 16. The tables of American rainfall arranged by Mr. Schott, and published in the same volume, are exceedingly valuable.

FIG. 4.

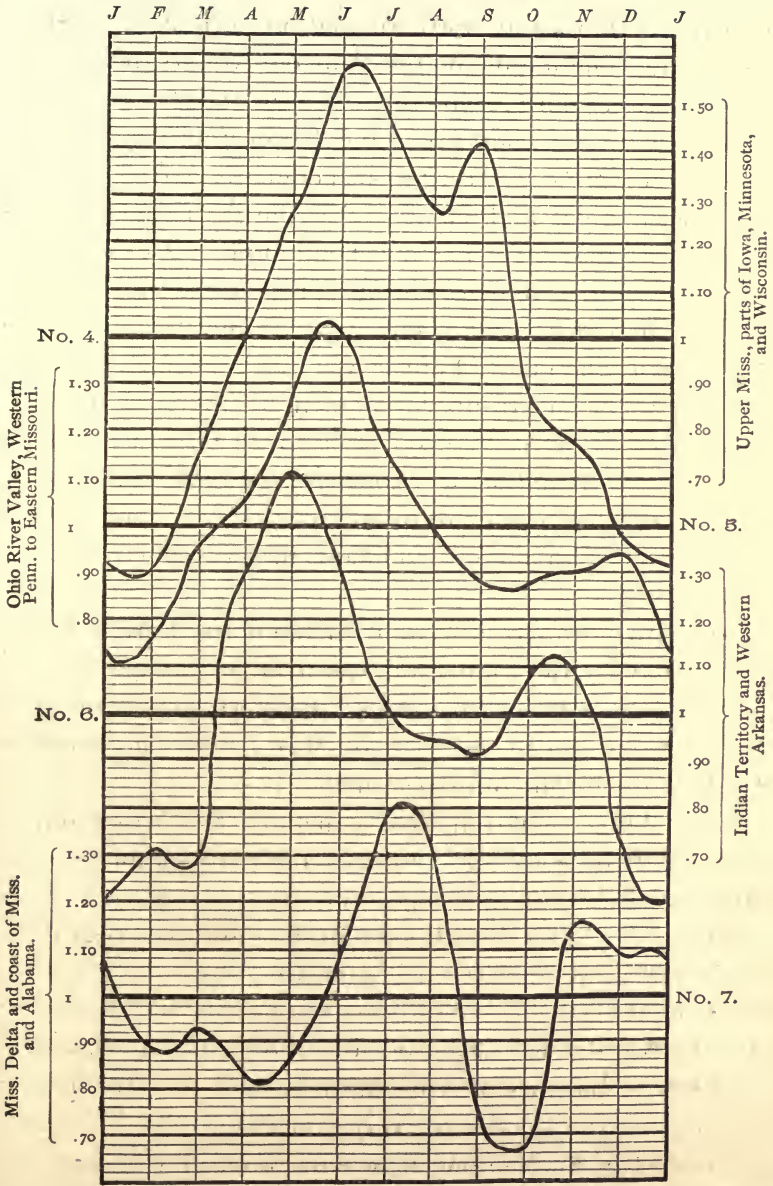

CURVES OF ANNUAL FLUCTUATIONS IN RAINFALL.

Curve No. 3, for Group No. 3, includes the upper Hudson River valley, and northern and western New York. The average fluctuation of the year is sixty-six per cent. Its maximum rainfall occurs oftenest near the first of July and its minimum oftenest about the first of February.

Curve No. 4, for Group No. 4, includes a part of Iowa, central Minnesota, and part of Wisconsin, in the upper Mississippi valley. The average fluctuation of the year is one hundred and nine per cent. Its maximum rainfall occurs oftenest in the latter part of June and its minimum oftenest about the first of February.

Curve No. 5, for Group No. 5, includes the Ohio River valley, from western Pennsylvania to eastern Missouri. The average fluctuation of the year is seventy-three per cent. Its maximum rainfall occurs oftenest about the first of June and its minimum oftenest in the latter part of January.

Curve No. 6, for Group No. 6, includes the Indian Territory and Western Arkansas. The average fluctuation of the year is ninety-one per cent. Its maximum rainfall occurs oftenest about the first of May and its minimum oftenest at the opening of the year.

Curve No. 8, for Group No. 8, includes the Mississippi Delta and Gulf coast of Alabama and Mississippi. The average fluctuation of the year is seventy-five per cent. Its maximum rainfall occurs oftenest in the latter part of July and its minimum oftenest early in October.

A similar type curve for Group No. 9, the region bordering upon the Pacific coast from the Bay of San Francisco to Puget's Sound, would show an average annual fluctuation through the seasons of two hundred and thirty-two per cent. The fluctuations here have nothing in common with the Mississippi and Atlantic types. The maximum

FIG. 5.

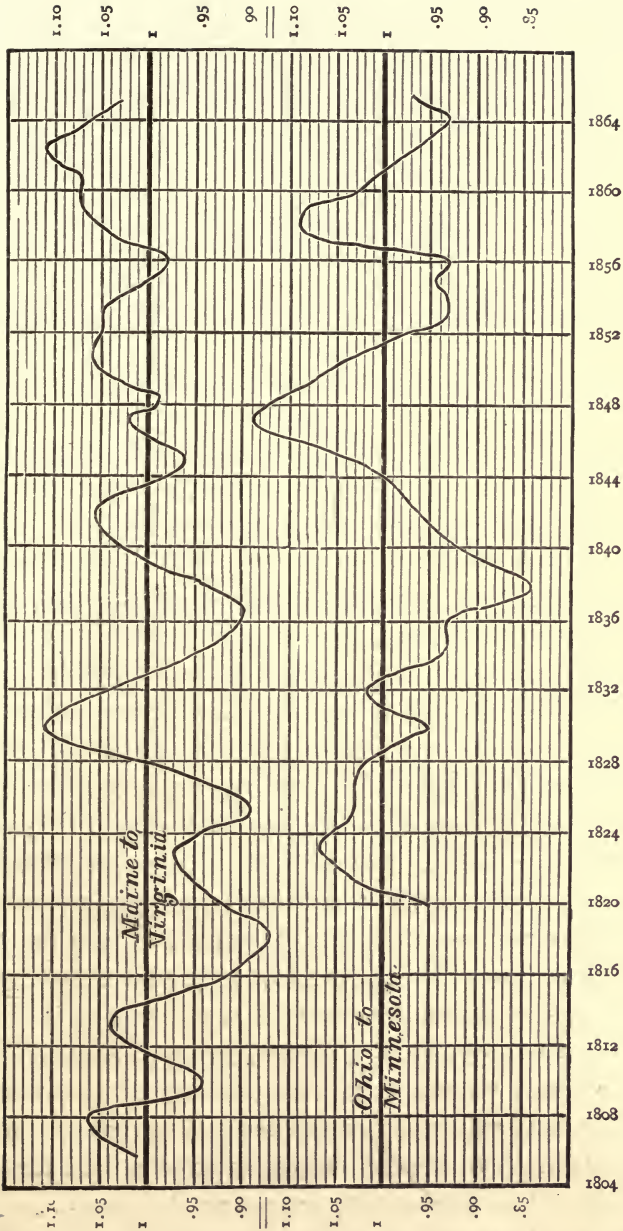

CURVES OF SECULAR FLUCTUATIONS IN RAINFALL.

rainfall here occurs oftenest in December and the minimum oftenest in July.

35. Secular Fluctuations in Rainfall.—Diagram 5 illustrates the secular fluctuations in the rainfall through a long series of years in the Atlantic system and in the central Mississippi system. It presents the successions of wet and dry periods as they vibrate back and forth about the mean of the whole period.

The extreme fluctuation is in the first case twenty-eight per cent., and in the second case thirty per cent.

36. Local, Physical, and Meteorological Influences.—The above statistics give sufficient data for determining approximately the general average rainfall in any one of the principal river-basins of the States.

There are local influences operating in most of the main physical divisions, analogous to those governing rainfall in the grand atmospheric systems.

Referring to any local watershed, and the detailed study of such is oftenest that of a limited gathering ground tributary to some river, we have to note especially the mean temperature and capacity of the atmosphere to bear vapor, the source from which the chief saturation of the atmosphere is derived, the prevailing winds at the different seasons, whether in harmony with or opposition to the direction of this source, and if any high lands that will act as condensers of the moisture lie in its path and filch its vapors, or if guiding ridges converge the summer showers in more than due proportion in a favored valley. A careful study of the local, physical, and meteorological influences will usually indicate quite unmistakably if the mean rainfall of a subordinate watershed is greater or less than that of the main basin to which its streams are tributary. There is rarely a sudden change of mean precipitation, except at the

crest of an elevated ridge or the brink of a deep and narrow ravine.

37. Uniform Effects of Natural Laws.—When studies of local rainfalls are confined to *mean* results, neglecting the occasional wide departures from the influence of the general controlling atmospheric laws, the actions of nature seem precise and regular in their successions, and in fact we find that the governing forces hold results with a firm bearing close upon their appointed line.

But occasionally they break out from their accustomed course as with a convulsive leap, and a storm rages as though the windows of heaven had burst, and floods sweep down the water-courses, almost irresistible in their fury. If hydraulic constructions are not built as firm as the everlasting hills, their ruins will on such occasions be borne along on the flood toward the ocean.

38. Great Rain Storms.—In October, 1869, a great storm moved up along the Atlantic coast from Virginia to New York, and passed through the heart of New England, with disastrous effect along nearly its whole course. Its rainfall at many points along its central path was from eight to nine inches, and its duration in New England was from forty to fifty-nine hours.

In August, 1874, a short, heavy storm passed over eastern Connecticut, when there fell at New London and at Norwich twelve inches* of rain within forty-eight hours, five inches of which fell in four hours. Such storms are rare upon the Atlantic coast and in the Middle and Western States.

Short storms of equal force, lasting one or two hours, are more common, and the flood effects from them, on hilly

* From data supplied by H. B. Winship, Supt. of Norwich Water-works.

watersheds, not exceeding one or two square miles area, may be equally disastrous, and waterspouts sometimes burst in the valleys and flood their streams.

39. Maximum Ratios of Floods to Rainfalls.--

When the surface of a small watershed is generally rocky, or impervious, or, for instance, when the ground is frozen and uncovered by snow, the maximum rate of volume of flow through the outlet channel may reach two-thirds of the average rate of volume of rain falling upon the gathering-ground.

40. Volume of Water from given Rainfalls.—The rates of volume of water falling per minute, for the rates of rainfall per twenty-four hours, indicated, are given in cubic feet per minute, per acre and per square mile, in the following table:

TABLE No. 8.

VOLUME OF RAINFALL PER MINUTE, FOR GIVEN INCHES PER TWENTY-FOUR HOURS.

RAINFALL PER 24 HOURS.	VOLUME PER MINUTE ON ONE ACRE.	VOLUME PER MINUTE ON ONE SQ. MILE.	RAINFALL PER 24 HOURS.	VOLUME PER MINUTE ON ONE ACRE.	VOLUME PER MINUTE ON ONE SQ. MILE.
<i>Inches.</i>	<i>Cu. feet.</i>	<i>Cu. feet.</i>	<i>Inches.</i>	<i>Cu. feet.</i>	<i>Cu. feet.</i>
0.1	.252	161.33	1	2.521	1613.33
.2	.504	322.67	2	5.042	3226.67
.3	.756	484.01	3	7.563	4840.00
.4	1.008	645.33	4	10.084	6453.33
.5	1.264	806.67	5	12.605	8066.65
.6	1.515	968.00	6	15.126	9689.99
.7	1.765	1122.73	7	17.647	11293.33
.8	2.107	1290.67	8	20.168	12906.66
.9	2.269	1450.00	9	22.689	14529.99
			10	25.210	16133.33

41. Gauging Rainfall.—A pluviometer, Fig. 6, is used to measure the amount of rain that falls from the sky. It is a deep, cylindrical, open-topped dish of brass. Its top

edge is thin, so it will receive just the rain due to the sectional area of the open top.

A convenient size is of two inches diameter at a , and at b of such diameter that its sectional area is exactly one-tenth the sectional area at a , or a little more than one-half inch.

When extreme accuracy is required, the diameter at a is made ten inches and at b a little more than three inches, still maintaining the ratio of sectional areas *ten to one*, the displacement of the measuring-rod being allowed for.

This rain-gauge should be set vertically in a smooth, open, level ground, and the grass around be kept smoothly trimmed in summer. The top of a ten-inch gauge is set at about one foot above the surface of the ground, and of smaller gauges, clear of the grass surface.

The gauge should be placed sufficiently apart from buildings, fences, trees, and shrubs, so that the volume of rain gathered shall not be augmented or reduced by wind-eddies.

If such a situation, secure from interference by animals or by mischievous persons, is not obtainable, the gauge may be set upon the flat roof of a building, and the height above the ground noted.

The measuring-rod for taking the depth of rain in b is graduated in inches and tenths of inches, so that when the sections of a and b are *ten to one*, ten inches upon the rod

FIG. 6.

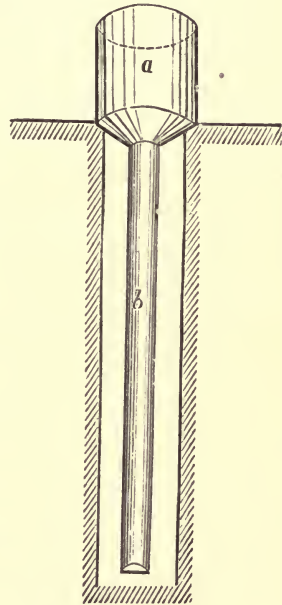

corresponds with one inch of actual rainfall, and one inch on the rod to one-tenth inch of rain, and one-tenth on the rod to one-hundredth of rain.

Snow is caught in a cylindrical, vertical-sided dish, not less than ten inches diameter, melted, and then measured as rain. Memorandums of depths of snow before melting, with dates, are preserved also.

It has been observed at numerous places, that elevated pluviometers indicated less rain than those placed in the neighboring ground. When there is wind during a shower, the path of the drops is parabolic, being much inclined in the air above and nearly vertical at the surface of the ground. A circular rain-gauge, held horizontally, presents to inclined drops an elliptic section, and consequently less effective area than to vertical drops.

The law due to height alone is not satisfactorily established, though several formulæ of correction have been suggested, some of which were very evidently based upon erroneous measures of rainfall.

The observed rainfall at Greenwich Observatory, England, in the year 1855, is reported, at ground level, 23.8 inches depth; at 22 feet higher, .807 of that quantity, and at 50 feet higher, .42 of that quantity.

The observed rainfall at the Yorkshire Museum, England, in the years 1832, 1833, and 1834, is reported, for yearly average, at ground level, 21.477 inches; at 44 feet higher, .81 as much, and at 213 feet higher, .605 as much.

Unless vigilantly watched during storms, the gauges are liable to overflow, when an accurate record becomes impossible. Overflow cups are sometimes joined to rain-gauges, near their tops, to catch the surplus water of great storms.

FIG. 127.

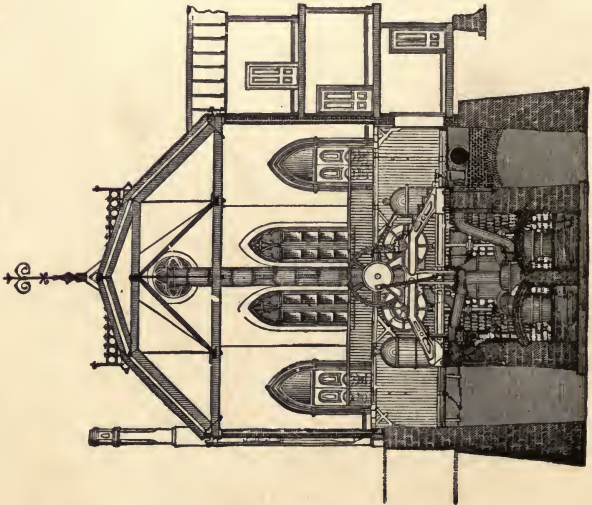
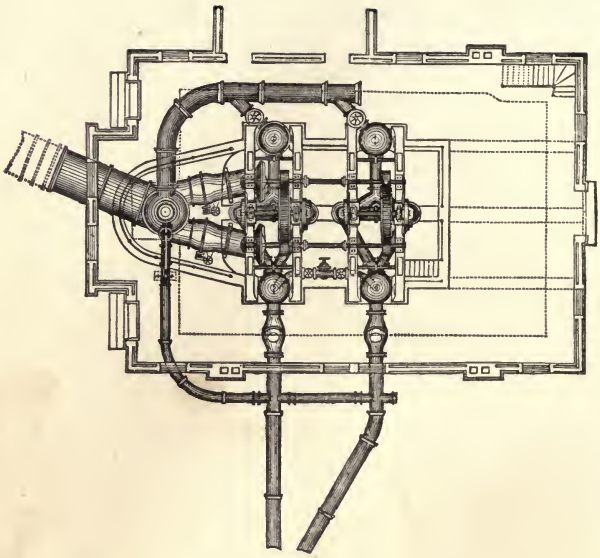

FIG. 128.



SECTION AND PLAN OF PUMP-HOUSE.

CHAPTER IV.

FLOW OF STREAMS.

42. Flood Volume Inversely as the Area of the Basin.—A rain, falling at the rate of one inch in twenty-four hours, delivers upon each acre of drainage area about 2.5 cubic feet of water each minute.

If upon one square mile area, with frozen or impervious surface, there falls twelve inches of rain in twenty-four hours, and two-thirds of this amount flows off in an equal length of time, then the average rate of flow will be 215 cubic feet per second.

Any artificial channel cut for a stream, or any dam built across it, must have ample flood-way, overfall, or waste-slucice to pass the flood at its maximum rate.

The rate of flood flow at the outlet of a watershed is usually much less from a large main basin than from its tributary basins, because the proportion of plains, storage ponds, and pervious soils is usually greater in large basins than in small, and the flood flow is consequently distributed through a longer time.

In a small tributary shed of steep slope the period of maximum flood flow may follow close after the maximum rainfall; but in the main channel of the main basin the maximum flood effect may not follow for one, two, three, or more days, or until the storm upon its upper valley has entirely ceased.

43. Formulæ for Flood Volumes.—The recorded flood measurements of American streams are few in number, but

upon plotting such data as is obtained, we find their mean curve to follow very closely that of the equation,

$$Q = 200 (M)^{\frac{5}{6}}, \quad (1)$$

in which M is the area of watershed in square miles and Q the volume of discharge, in cubic feet per second, from the whole area.

Thus the decrease of flood with increase of area is seen to follow nearly the ratio of two hundred times the sixth root of the fifth power of the area expressed in square miles.

Among the Indian Professional Papers we find the following formula for volume, in cubic feet per second :

$$Q = c \times 27 (M)^{\frac{1}{2}}. \quad (2)$$

in which c is a co-efficient, to which Colonel Dickens has given a mean value of 8.25 for East Indian practice.

Testing this formula by our American curve, we find the following values of c for given areas :

Area in sq. miles...	1.	2.	3.	4.	6.	8.	10.	15.	20.	30.	40.	50.	75.	100.
Value of c	7.41	9.33	10.68	11.76	13.46	14.83	15.96	18.26	20.11	23.02	25.33	27.28	31.26	34.38

Mr. Dredge suggests, also in Indian Professional Papers, the following formula :

$$Q = 1300 \frac{M}{L^{\frac{1}{3}}}, \quad (3)$$

in which L is the length of the watershed, and M the area in square miles.

Our formula, modified as follows, gives an approximate flood volume per square mile, in cubic feet per second :

$$Q = \frac{200(M)^{\frac{5}{6}}}{M} \quad (4)$$

in which M is the area of the given watershed in square miles.

44. **Table of Flood Volumes.**—Upon the average New England and Middle State basins, maximum floods may be anticipated with rates of flow, as per the following table:

TABLE No. 9.

FLOOD VOLUMES FROM GIVEN WATERSHEDS.

AREA OF WATER-SHED.	FLOOD DISCHARGE FOR WHOLE AREA, $Q = 200(M)^{.6}$.	FLOOD DISCHARGE PER SQUARE MILE, $Q = \frac{200(M)^{.6}}{M}$.	FLOOD DISCHARGE PER ACRE.
<i>Sq. Miles.</i>	<i>Cu. Feet per Second.</i>	<i>Cu. Feet per Second.</i>	<i>Cu. Feet per Minute.</i>
0.5	112	225.00	21.15
1	200	200.00	18.75
2	356	178.20	16.75
3	500	166.53	15.65
4	635	159.25	14.96
6	890	148.37	13.94
8	1131	141.42	13.29
10	1363	136.26	12.80
15	1910	127.33	11.97
20	2428	121.40	11.41
25	2925	117.00	11.00
30	3404	113.47	10.66
40	4326	108.15	10.16
50	5208	104.16	9.82
75	7304	97.39	9.15
100	9282	92.82	8.72
200	16542	82.71	7.77
300	23190	77.30	7.26
400	29480	73.70	6.93
500	35500	71.00	6.67
600	41320	68.87	6.46
800	52520	65.65	6.16
1000	63260	63.26	5.94
1500	88680	59.12	5.55
2000	112600	56.30	5.29
3000	158000	52.67	4.94
4000	200800	50.20	4.72
5000	241800	48.36	4.54

45. Seasons of Floods.—Great floods occur only when peculiar combinations of circumstances favor such result.

A knowledge of the magnitude of the floods upon any river, and of their usual season, is invaluable to the director of constructions upon that stream, to enable him to take such precautionary measures as to be always prepared for them. Such knowledge is also requisite to enable him to compute the storage capacity required to save and utilize such flood, or to calculate the sectional area of waste weir required upon dams to safely pass the same.

Long rivers, having their sources upon northern mountain slopes, have usually well-known seasons of flood, dependent upon the melting of snows; but small watersheds in many sections of America are subject to flood, alike, at all seasons.

46. Influence of Absorption and Evaporation upon Flow.—The rainfall upon the Atlantic coast and upon the Mississippi valley appears comparatively uniform when noted in its monthly classification, but the ability of any one of their watersheds to supply, from flow of stream, a domestic demand equal to its mean flow is by no means as uniform.

We have seen that, according to the statistics quoted, the consumption of water is not as uniform, when noted by monthly classification, as is the monthly rainfall. When lesser classifications of rainfall and consumption are compared, there is scarce a trace of identity in their plotted irregular profiles.

Evaporation, though comparatively uniform in its monthly classification, is very irregular as observed in its lesser periods.

In the spring and early summer, when vegetation is in

most thrifty growth, the innumerable rootlets of flowers, grasses, shrubs, and forests, gather in a large proportion of rainfall, and pass it through their arteries and back into the atmosphere beyond reach for animal uses.

47. Flow in Seasons of Minimum Rainfall.—In gathering, basins having limited pondage or available storage of rainfall, the flow from minimum annual, and minimum periodic rainfall demands especial study. Occasionally the annual rainfall continues less than the general mean through cycles of three or four years, as is indicated in the above diagram of curves of secular rainfall. The mean rain of such cycles of low-rainfall is occasionally less than eight-tenths of the general mean.

We have selected for data upon this point the rainfall records of twenty-one stations, of longest observation in the United States, at various points from Maine to Louisiana and from California to Sitka. The computation gives the annual rainfall of the least three-year cycle at any one of these points as .67 of the general mean annual rain at the same point, and annual rainfall of the greatest three-year *low* cycle as .97 of the general mean at the same point. An average of all these stations gives the three-year low cycle rainfall as .81 of the average mean annual rainfall.

48. Periodic Classification of Rainfall Available in Flow.—Next, the rainfall and the portion of it that can be made available, demands especial study in its monthly, or less periodic classification. It is desirable to know the ratio of each month's average fall to the mean monthly fall for the year, and the percentage of this fall that is exempted from absorptions by vegetation and evaporations into the atmosphere, and that flows from springs, and in the streams, since it is ordained by Nature that the lily and the oak with their seed, shall first be supplied and the atmospheric

processes be maintained, and the surplus rain be dedicated to the animal creation, as their necessities demand and ingenuities permit them to make available.

49. Sub-surface Equalizers of Flow.—The interstices of the soils and the crevices of the rocks were filled long ages ago, and now regularly aid in equalizing the flow of the springs and streams without, to any considerable extent, affecting the total annual flow, yet their influence is observable in cycles of droughts when the sub-surface water level is drawn slowly down.

The substructure of each given watershed has its individual storage peculiarities which may increase or diminish the monthly flow and degree of regularity of flow of its streams to an important extent.

If a porous subsoil of great depth and storage capacity is overlaid with a thin crust of soil through which water percolates slowly, a great flood-rain may fall suddenly over the nearly exhausted sub-reservoir and be run off to the rivers without replenishing appreciably the waning springs, or increasing their flow as would an ordinary slow rainfall.

On the other hand, if its surface soil is open and absorbent, it may be able to receive nearly the whole flood and distribute it gradually from its springs.

The early sealing over of the subsoil by winter frosts before the usual subterranean storage has accumulated from winter storms, or a shedding of the melting snows in spring by a like frost-crust, may result in a diminished flow of the deep springs in the following summer.

Subsoils that exhaust themselves in ordinary seasons are comparatively valueless to sustain the flow in the second and third years of cycle droughts.

Steep and impervious earths yield no springs, but gather their waters rapidly in the draining streams.

50. Flashy and Steady Streams.—Upon the steep and rocky watersheds of northern New Hampshire, we find extreme examples of “flashy” streams that are furious in storm and vanish in droughts.

Upon the saturated sands of Hempstead Plains on Long Island, N. Y., we find an opposite extreme of constant and even flow, where a great underground reservoir co-extensive with its supplying watershed, feeds its streams with remarkable uniformity.

Almost all degrees of constancy and fickleness of flow are to be found in the several sub-section streams of any one of our great river basins.

51. Peculiar Watersheds.—The extremes or results from peculiar watersheds, are in all cases to be considered *as extremes* when their individual merits and capacities of supply are investigated, and the investigation may often take the direction of determining the relations of its results to results from a general mean, or ordinary watershed, especially as respects its mean temperature, its mean humidity of atmosphere, the direction from whence its storms come, the frequency of its storm winds, the extent of its storms in the different seasons, the imperviousness or the porosity of its soils and rocks, the proportions of its steep, gently undulating, and flat surfaces, and also it is to be observed if it can be classed among those rare instances in which one watershed is tributary as giver to or receiver from another basin, involving an investigation of its geological substructure.

52. Summaries of Monthly Flow Statistics.—We have analyzed some valuable statistics of monthly rainfalls, and measured flow of streams in Massachusetts and New York State, which are too voluminous for reproduction here, and present the deduced results. The records

are, first, from a report by Jos. P. Davis, C. E., relating to the watershed of Cochituate Lake, which has supplied the city of Boston with water until supplemented in 1876 from the Sudbury River watershed; second, from a table compiled by Jas. P. Kirkwood, C. E., relating to the watershed of Croton River above the Croton Dam; and third, from a paper read by J. J. R. Croes, C. E., before the American Society of Civil Engineers, July, 1874, relating to the watershed of the West Branch of the Croton River.

The summaries are as follows:

TABLE NO. 10.

SUMMARY OF RAINFALL UPON THE COCHITUATE BASIN.

Average annual, 55.032 inches; average monthly, 4.586 inches.

	Jan.	Feb.	Mar.	Apr.	May.	June.	July.	Aug.	Sept.	Oct.	Nov.	Dec.
Mean	<i>in.</i> 3.69	<i>in.</i> 4.03	<i>in.</i> 5.35	<i>in.</i> 4.58	<i>in.</i> 5.69	<i>in.</i> 3.09	<i>in.</i> 5.23	<i>in.</i> 4.91	<i>in.</i> 3.81	<i>in.</i> 5.86	<i>in.</i> 5.26	<i>in.</i> 3.52
Minimum	1.31	.98	2.51	1.94	2.66	.58	1.06	2.03	.64	1.19	2.63	.45
Maximum	7.85	5.80	8.44	11.34	8.25	5.96	14.12	12.36	8.49	9.50	8.54	5.98
Ratio of monthly mean.....	.806	.878	1.167	.998	1.241	.675	1.141	1.070	.831	1.300	1.147	.768

TABLE NO. 11.

SUMMARY OF RAINFALL UPON THE CROTON BASIN.

Average annual, 46.497 inches; average monthly, 4.227 inches.

	Jan.	Feb.	Mar.	Apr.	May.	June.	July.	Aug.	Sept.	Oct.	Nov.	Dec.
Mean.....	<i>in.</i> 2.54	<i>in.</i> 3.15	<i>in.</i> 3.16	<i>in.</i> 3.12	<i>in.</i> 6.40	<i>in.</i> 4.58	<i>in.</i> 4.31	<i>in.</i> 6.03	<i>in.</i> 5.30	<i>in.</i> 4.70	<i>in.</i> 3.83	<i>in.</i> 3.60
Minimum.....	.96	1.15	1.89	2.48	4.78	2.51	2.31	2.30	2.23	.74	3.09	1.86
Maximum.....	4.18	5.03	5.64	4.32	10.18	6.19	8.12	9.21	13.35	8.74	5.36	6.86
Ratio of monthly mean.....	.625	.745	.749	.739	1.513	1.084	1.020	1.427	1.259	1.111	.905	.851

TABLE NO. 12.

SUMMARY OF RAINFALL UPON CROTON WEST-BRANCH BASIN.

Average annual, 44.429 inches; average monthly, 4.039 inches.

	Jan.	Feb.	Mar.	Apr.	May.	June.	July.	Aug.	Sept.	Oct.	Nov.	Dec.
Mean.....	<i>in.</i> 3.16	<i>in.</i> 3.20	<i>in.</i> 3.30	<i>in.</i> 3.84	<i>in.</i> 5.08	<i>in.</i> 4.32	<i>in.</i> 4.59	<i>in.</i> 6.59	<i>in.</i> 2.90	<i>in.</i> 5.24	<i>in.</i> 3.10	<i>in.</i> 3.16
Minimum.....	1.44	1.22	2.55	3.01	2.30	2.06	3.43	5.10	1.44	2.15	2.43	1.49
Maximum.....	4.51	6.40	4.27	5.45	8.79	5.73	5.52	10.04	3.69	9.46	4.35	5.96
Ratio of monthly mean.....	.783	.767	1.296	.718	1.633	1.136	1.070	1.257	.951	.818	.793	.783

TABLE NO. 13.

SUMMARY OF PERCENTAGE OF RAINFALL FLOWING FROM THE COCHITUATE BASIN.

Average percentage of average annual rainfall flowing off, 45.6.

	Jan.	Feb.	Mar.	Apr.	May.	June.	July.	Aug.	Sept.	Oct.	Nov.	Dec.
Mean.....	<i>in.</i> 52.5	<i>in.</i> 79.7	<i>in.</i> 71.3	<i>in.</i> 80.5	<i>in.</i> 45.1	<i>in.</i> 35.1	<i>in.</i> 20.3	<i>in.</i> 20.0	<i>in.</i> 24.5	<i>in.</i> 26.5	<i>in.</i> 27.8	<i>in.</i> 64.3
Minimum.....	33	26	44	39	20	9	9	14	13	10	20	24
Maximum.....	79	159	153	124	76	84	39	27	39	80	42	261
Ratio of monthly mean.....	1.51	1.75	1.56	1.77	.97	.770	.44	.44	.54	.58	.61	1.41

TABLE NO. 14.

SUMMARY OF PERCENTAGE OF RAINFALL FLOWING FROM THE CROTON BASIN.

Average percentage of average annual rainfall flowing off, 57.47.

	Jan.	Feb.	Mar.	Apr.	May.	June.	July.	Aug.	Sept.	Oct.	Nov.	Dec.
Mean.....	<i>in.</i> 79.68	<i>in.</i> 75.0	<i>in.</i> 86.72	<i>in.</i> 80.60	<i>in.</i> 48.45	<i>in.</i> 45.02	<i>in.</i> 21.02	<i>in.</i> 19.45	<i>in.</i> 30.10	<i>in.</i> 81.13	<i>in.</i> 60.40	<i>in.</i> 62.12
Minimum.....	49.0	62.1	21.9	53.5	42.8	18.6	8.5	8.4	10.2	7.6	36.3	39.0
Maximum.....	123.4	107.0	147.4	125.7	56.4	67.4	29.6	42.2	92.0	366.5	94.1	94.5
Ratio of monthly mean.....	1.386	1.305	1.509	1.402	.843	.783	.369	.338	.524	1.412	1.051	1.081

TABLE No. 15.

SUMMARY OF PERCENTAGE OF RAINFALL FLOWING FROM THE CROTON
WEST-BRANCH BASIN.

Average percentage of average annual rainfall flowing off, 70.98.

	Jan.	Feb.	Mar.	Apr.	May.	June.	July.	Aug.	Sept.	Oct.	Nov.	Dec.
Mean.....	<i>in.</i> 102.8	<i>in.</i> 71.1	<i>in.</i> 158.9	<i>in.</i> 117.2	<i>in.</i> 80.5	<i>in.</i> 44.8	<i>in.</i> 19.0	<i>in.</i> 24.6	<i>in.</i> 26.6	<i>in.</i> 30.4	<i>in.</i> 78.9	<i>in.</i> 97.0
Minimum.....	17.7	59.0	103.0	93.2	46.7	17.6	7.3	3.4	3.3	11.2	40.5	65.6
Maximum.....	186.6	103.9	209.1	158.4	100.3	71.2	31.4	53.8	39.8	56.3	110.2	140.8
Ratio of monthly mean.....	1.448	1.001	2.238	1.651	1.134	.636	.267	.347	.375	.428	1.112	1.367

TABLE No. 16.

SUMMARY OF VOLUME OF FLOW OF RAINFALL FROM THE COCHITUATE
BASIN (in cubic feet per minute per square mile).

	Jan.	Feb.	Mar.	Apr.	May.	June.	July.	Aug.	Sept.	Oct.	Nov.	Dec.
Mean.....	<i>cu.ft.</i> 99.17	<i>cu.ft.</i> 150.42	<i>cu.ft.</i> 174.76	<i>cu.ft.</i> 169.80	<i>cu.ft.</i> 131.80	<i>cu.ft.</i> 44.27	<i>cu.ft.</i> 45.27	<i>cu.ft.</i> 49.15	<i>cu.ft.</i> 42.84	<i>cu.ft.</i> 62.45	<i>cu.ft.</i> 75.90	<i>cu.ft.</i> 78.94
Minimum.....	37.99	58.29	91.60	70.44	67.14	18.28	21.34	21.34	4.30	36.43	47.32	40.07
Maximum.....	245.12	301.90	242.52	369.40	321.11	85.49	154.57	109.29	99.48	123.34	105.39	164.98
Ratio of monthly mean.....	1.058	1.605	1.865	1.812	1.406	.472	.483	.524	.457	.666	.809	.842

TABLE No. 17.

SUMMARY OF VOLUME OF FLOW OF RAINFALL FROM THE CROTON
BASIN (in cubic feet per minute per square mile).

	Jan.	Feb.	Mar.	Apr.	May.	June.	July.	Aug.	Sept.	Oct.	Nov.	Dec.
Mean.....	<i>cu.ft.</i> 91.48	<i>cu.ft.</i> 147.69	<i>cu.ft.</i> 177.02	<i>cu.ft.</i> 132.63	<i>cu.ft.</i> 164.49	<i>cu.ft.</i> 115.12	<i>cu.ft.</i> 48.37	<i>cu.ft.</i> 70.22	<i>cu.ft.</i> 85.99	<i>cu.ft.</i> 81.08	<i>cu.ft.</i> 124.92	<i>cu.ft.</i> 106.23
Minimum.....	48.08	40.65	79.05	87.43	108.25	34.09	10.46	13.12	12.91	18.05	61.41	72.08
Maximum.....	127.71	293.01	25.709	188.95	298.98	224.33	81.76	202.19	275.95	141.14	201.30	146.24
Ratio of monthly mean.....	.816	1.317	1.579	1.183	1.467	1.027	.431	.627	.767	.723	1.114	.948

TABLE No. 18.

 SUMMARY OF VOLUME OF FLOW OF RAINFALL FROM THE CROTON
 WEST-BRANCH BASIN (in cubic feet per minute per square mile).

	Jan.	Feb.	Mar.	Apr.	May.	June.	July.	Aug.	Sept.	Oct.	Nov.	Dec.
	<i>cu. ft.</i>	<i>cu. ft.</i>	<i>cu. ft.</i>	<i>cu. ft.</i>	<i>cu. ft.</i>	<i>cu. ft.</i>	<i>cu. ft.</i>	<i>cu. ft.</i>	<i>cu. ft.</i>	<i>cu. ft.</i>	<i>cu. ft.</i>	<i>cu. ft.</i>
Mean.....	158.95	185.19	290.56	272.60	161.60	103.86	40.02	103.12	147.59	96.26	107.85	164.07
Minimum.....	35.08	47.16	203.58	146.04	26.19	45.18	19.26	9.06	5.16	27.48	5.92	50.88
Maximum.....	347.88	378.90	390.83	463.98	394.92	202.02	85.56	281.04	477.22	277.26	203.28	299.16
Ratio of monthly mean.....	1.041	1.213	1.904	1.786	1.059	.680	.262	.676	.967	.631	.707	1.075

53. Minimum, Mean, and Flood Flow of Streams.

—An analysis of the published records of volumes of water flowing in the streams in all the seasons has led to the following approximate estimate of volumes of flow in the average Atlantic coast basins :

The *minimum* refers to a fifteen days' period of least summer flow.

The *mean* refers to a one hundred and twenty days' period, covering usually July, August, September, and October, beginning sometimes earlier, in June, and ending sometimes later, in November.

The *maximum* refers to flood volumes.

TABLE No. 19.

ESTIMATES OF MINIMUM, MEAN, AND MAXIMUM FLOW OF STREAMS.

Area of watershed, I sq. mi.	Min. in cu. ft. per sec. per sq. mi.	Mean in cu. ft. per sec. per sq. mi.	Max. in cu. ft. per sec. per sq. mi.
.083,		1.00	200
" " " 10 "	.1	.99	136
" " " 25 "	.11	.98	117
" " " 50 "	.14	.97	104
" " " 100 "	.18	.95	93
" " " 250 "	.25	.90	80
" " " 500 "	.30	.87	71
" " " 1000 "	.35	.82	63
" " " 1500 "	.38	.80	59
" " " 2000 "	.41	.79	56

This table refers to streams of average natural pondage and retentiveness of soil, but excludes effects of artificial storage. The fluctuations of streams will be greater than indicated by the table when prevailing slopes are steep and rocks impervious, and less in rolling country with pervious soils.

54. Ratios of Monthly Flow in Streams.—A careful analysis of the published records of monthly flow of the average Atlantic coast streams leads to the following approximate estimate of the ratio of the monthly mean rainfall that flows down the streams in each given month of the year, in which due consideration of the evaporation from soils and foliage in very dry seasons has not been neglected.

TABLE No. 20.
MONTHLY RATIOS OF FLOW OF STREAMS.

	Jan.	Feb.	March.	April.	May.	June.	July.	Aug.	Sept.	Oct.	Nov.	Dec.
Ratio of flow .	1.65	1.50	1.65	1.45	.85	.75	.35	.25	.30	.45	1.20	1.60

Here unity equals the *mean* monthly flow, or one-twelfth the mean annual flow.

To compute, approximately, the inches depth of rain flowing in the streams each month, one-twelfth the mean annual rain, at the given locality, may be multiplied by the ratios in the following table. For illustration, a mean annual rain of 40 inches depth, giving 3.333 inches mean monthly depth, is assumed, and the available flow of stream expressed in inches depth of rain is added after the ratios.

TABLE No. 21.

RATIOS OF MEAN MONTHLY RAIN, AND INCHES OF RAIN FLOWING EACH MONTH.

	Jan.	Feb.	Mar.	Apr.	May.	June.	July.	Aug.	Sept.	Oct.	Nov.	Dec.
Ratios of mean monthly rain.	.825	.750	.825	.725	.425	.375	.175	.125	.150	.225	.600	.800
Inches of rain flowing.	2.75	2.50	2.75	2.41	1.41	1.25	0.59	0.41	0.50	0.75	2.00	2.66
Eight-tenths of same.	2.20	2.00	2.20	1.93	1.13	1.00	0.47	0.33	0.40	0.60	1.60	2.13

For low-cycle years, use eight-tenths (§ 47) the available monthly depth of rain flowing.

¶ 55. **Mean Annual Flow of Streams.**—When monthly data of the flow of any given stream is not obtainable, it may ordinarily be taken upon average drainage areas, for an annual flow, as equal to fifty per cent. of the annual rainfall.

Or, for different surfaces, its ratio of the annual rain, including floods and flow of springs, is more approximately as follows :

- From mountain slopes, or steep rocky hills80 to .90
- Wooded, swampy lands.60 to .80
- Undulating pasture and woodland.50 to .70
- Flat cultivated lands and prairie.45 to .60

Since stations for meteorological observations are now established in or near almost all the populous neighborhoods, and some of the stations have already been established more than a quarter of a century, it is easier to obtain data relating to rainfall than to the flow of streams. In fact, the required data relating to a given stream is rarely obtainable, and the estimates relating to the capacity and

reliability of the stream to furnish a given water-supply must necessarily be quite speculative.

56. Estimates of Flow of Streams.—In such case, an estimate of the capacity of a stream to deliver into a reservoir, conduit, or pump-well is computed according to some scheme suggested by extended observations and study of streams and their watersheds, and long experience in the construction of water supplies.

The first reconnoissance of a given watershed by an expert in hydrology will ordinarily enable him to judge very closely of its capacity to yield an available and suitable water supply; for his comprehension at once grasps its geological structure, its physical features and its usual meteorological phenomena, and his educated judgment supplies the necessary data, as it were, instinctively.

If the estimate of flow of a stream must be worked up from a survey of the watershed area and the mean annual rainfall, as the principal data, then recourse may be had to the data and estimates given above, relating to the question, for average upland basins of one hundred or less square miles area.

In illustration, let us assume a basin of one square mile area, having a forty-inch average annual rainfall, and then proceed with a computation. This is a convenient unit of area upon which to base computations for larger areas.

The ratios of the three-year low rain cycles gives their mean rainfall as about eight-tenths of the general mean rainfall. We assume it to be eighty per cent. The mean annual flow of the stream we assume to be fifty per cent. of the annual rainfall. Eight-tenths of fifty per cent. gives forty per cent. of the annual rainfall as the annual available flow of the stream, and forty per cent. of the forty inches rainfall gives an equivalent of sixteen inches of rainfall

flowing down the stream annually. The monthly average flow is then taken as one-twelfth of sixteen, or one and one-third inches. Our estimated monthly percentage of mean flow, as given above (§ 54), is sometimes much in excess and sometimes less than the monthly average. Flows less than the mean are to be compensated for by a proportionate increase of storage above the mean storage required.

The monthly computations are as follows:

$$\text{Monthly mean} = \frac{40 \text{ inches} \times 50 \text{ per cent.} \times .8}{12 \text{ months}} = 1.333$$

inches average available rain monthly. This average multiplied by the respective ratios of flow in each month gives the inches depth of available rain flowing in the respective months, thus:

	MEAN MONTHLY RAINFALL.		RESPECTIVE RATIOS.		INCHES DEPTH OF AVAILABLE RAIN FLOWING EACH MONTH.
January.....	1.333	×	1.65	=	2.20
February.....	"	×	1.50	=	2.00
March.....	"	×	1.65	=	2.20
April.....	"	×	1.45	=	1.93
May.....	"	×	.85	=	1.13
June.....	"	×	.75	=	1.00
July.....	"	×	.35	=	.47
August.....	"	×	.25	=	.33
September.....	"	×	.30	=	.40
October.....	"	×	.45	=	.60
November.....	"	×	1.20	=	1.60
December.....	"	×	1.60	=	2.14

Again, uniting the constants, we have $\frac{.8 \times .50}{12} = .0333$,

which, multiplied by the respective ratios of monthly flow, thus: Jan., $.0333 \times 1.65 = .055$, etc., gives directly the mean ratio of the low cycle annual rainfall that is available in the stream each month.

				FLOW IN CU. FT. PER MINUTE PER SQ. MI. IN EACH MONTH.	
Jan.....	40 inches	×	.055	=	2.20 inches depth = 116.60
Feb.....	"	×	.050	=	2.00 " = 106.00
March...	"	×	.055	=	2.20 " = 116.60
April ...	"	×	.0483	=	1.93 " = 102.29
May.....	"	×	.0283	=	1.13 " = 59.89
June.....	"	×	.025	=	1.00 " = 53.00
July.....	"	×	.012	=	.47 " = 24.91
Aug.....	"	×	.0083	=	.33 " = 17.49
Sept.....	"	×	.010	=	.40 " = 21.20
Oct.....	"	×	.015	=	.60 " = 31.80
Nov.....	"	×	.040	=	1.60 " = 84.80
Dec.....	"	×	.0533	=	2.14 " = 113.42
Total,				16.00 inches.	Mean, 70.67 cu. ft.

57. Ordinary Flow of Streams.—Mr. Leslie has proposed* an arbitrary rule for computing the “average summer discharge” or “ordinary” flow of a stream, from the daily gaugings, as follows:

“Range the discharges as observed daily in their order of magnitude.

“Divide the list thus arranged into an upper quarter, a middle half, and a lower quarter.

“The discharges in the upper quarter of the list are to be considered as *floods*, and in the lower quarter as *minimum flows*.

“For each of the gaugings exceeding the average of the middle half, including flood gaugings, substitute the *average of the middle half of the list*, and take the mean of the whole list, as thus modified, for the *ordinary* or *average discharge, exclusive of flood-waters*.”

This rule applied to a number of examples of actual measurements of streams in hilly English districts gave computed ordinary discharges ranging from one-fourth to

* Minutes of Proceedings of Institution of Civil Engineers, Vol. X, p. 327.

one-third of the *measured mean discharge, including floods.*

The ordinary flow of New England streams is, at an average, equivalent to about one million gallons per day per square mile of drainage area, which expressed in cubic feet, equals about ninety-two cubic feet per minute per square mile.

The above computation for the average flow in low cycle years gives a little less than eight-tenths of this amount, or seventy-one cubic feet per minute per square mile as the average flow throughout the year, and a little less than one-fourth this amount as the minimum monthly flow.*

58. Tables of Flow Equivalent to Given Depths of Rain.—To facilitate calculations, tables giving the equivalents of various depths of monthly and annual rain-falls, in even continuous flow, in cubic feet per minute per acre, and per square mile, are here inserted.

Greater or less numbers than those given in Tables 22 and 23 may be found by addition, or by moving the decimal point; thus, from Table 22, for 40.362 inches depth, take

Depth, 30	inches	=	1590.204	cu. ft.
10	"	=	530.068	"
.3	"	=	15.902	"
.06	"	=	3.180	"
.002	"	=	.106	"
40.362	inches	=	2139.460	cu. ft.

To reduce the flows in the two tables to equivalent volumes of flow for like depths of rain in ONE DAY, divide the flows in Table 22 by 30.4369 (log. = 1.483400), and divide the flows in Table 23 by 365.2417 (log. = 2.562581).

* Some useful data relating to the flow of certain British and Continental streams may be found in Beardmore's "Manual of Hydrology," p. 149 (London, 1862).

TABLE NO. 22.

EQUIVALENT VOLUMES OF FLOW, FOR GIVEN DEPTHS OF RAIN IN ONE MONTH.*

DEPTHS OF RAIN IN ONE MONTH.	EQUIVALENT FLOW IN CUBIC FEET PER MINUTE PER ACRE.	EQUIVALENT FLOW IN CU- BIC FEET PER MINUTE PER SQUARE MILE.	EQUIVALENT FLOW IN CU- BIC FEET PER MONTH PER SQUARE MILE.
<i>Inches.</i>			
.01	.00083	.530	23,232
.02	.00166	1.060	46,464
.03	.00248	1.590	69,696
.04	.00331	2.120	92,928
.05	.00414	2.650	116,160
.06	.00497	3.180	139,392
.07	.00580	3.710	162,624
.08	.00662	4.240	185,856
.09	.00745	4.770	209,088
.1	.00828	5.3007	232,320
.2	.01656	10.6014	464,640
.3	.02484	15.9020	696,960
.4	.03312	21.2027	929,280
.5	.04140	26.5034	1,161,600
.6	.04968	31.8041	1,393,920
.7	.05796	37.1048	1,626,240
.8	.06624	42.4054	1,858,560
.9	.07452	47.7061	2,090,880
1.0	.0828	53.0068	2,323,200
2	.1656	106.0136	4,646,400
3	.2484	159.0204	6,969,600
4	.3312	212.0272	9,292,800
5	.4140	265.0340	11,616,000
6	.4868	318.0408	13,939,200
7	.5796	371.0476	16,262,400
8	.6624	424.0544	18,585,600
9	.7452	477.0612	20,908,800
10	.828	530.068	23,232,000
20	1.656	1060.136	46,464,000
30	2.484	1590.204	69,696,000

* One month is taken equal to 30.4369 days.

TABLE No. 23.

EQUIVALENT VOLUME OF FLOW, FOR GIVEN DEPTHS OF RAIN IN ONE YEAR.*

DEPTHS OF RAIN IN ONE YEAR.	EQUIVALENT FLOW IN CUBIC FEET PER MINUTE PER ACRE.	EQUIVALENT FLOW IN CU- BIC FEET PER MINUTE PER SQUARE MILE.	EQUIVALENT FLOW IN CU- BIC FEET PER YEAR PER SQUARE MILE.
<i>Inches.</i>			
.01	.000069	.0442	23,232
.02	.000138	.0883	46,464
.03	.000207	.1325	69,696
.04	.000276	.1767	92,928
.05	.000345	.2209	116,160
.06	.000414	.2650	139,392
.07	.000483	.3092	162,624
.08	.000552	.3534	185,856
.09	.000621	.3976	209,088
.1	.00069	.4417	232,320
.2	.00138	.8834	464,640
.3	.00207	1.3252	696,960
.4	.00276	1.7669	929,280
.5	.00345	2.2086	1,161,600
.6	.00414	2.6503	1,393,920
.7	.00483	3.0921	1,626,240
.8	.00552	3.5338	1,858,560
.9	.00621	3.9755	2,090,880
1.0	.0069	4.4172	2,323,200
2	.0138	8.8345	4,646,400
3	.0207	13.2517	6,969,600
4	.0276	17.6689	9,292,800
5	.0345	22.0862	11,616,000
6	.0414	26.5034	13,939,200
7	.0483	30.9206	16,262,400
8	.0552	35.3379	18,585,600
9	.0621	39.7551	20,908,800
10	.069	44.1723	23,232,000
20	.138	88.3447	46,464,000
30	.207	132.5170	69,696,000
40	.276	176.6894	92,928,000
50	.345	220.8617	116,160,000
60	.414	265.0340	139,392,000

* One year is taken, equal to 365 days, 5 hours, 49 minutes.

CHAPTER V.

STORAGE AND EVAPORATION OF WATER.

STORAGE.

59. Artificial Storage.—The fluctuations of the rainfall, flow of streams, and consumption of water in the different seasons of the year, require almost invariably that, for *gravitation* and *hydraulic power pumping supplies*, there shall be artificial storage of the surplus waters of the seasons of maximum flow, to provide for the draught during the seasons of minimum flow. A grand exception to this general rule is that of the natural storage of the chain of great lakes that equalizes the flow of the St. Lawrence River, which furnishes the domestic water supply of the City of Montreal and the hydraulic power to pump the same to the reservoir on the mountain.

When the mean annual consumption, whether for domestic use, or for power and domestic use combined is nearly equal to the mean annual flow of the supplying watershed, the question of ample storage becomes of supreme importance. The chief river basins of Maine present remarkable examples of natural storage facilities, since they have from six to thirteen per cent., respectively, of their large watershed areas in pond and lake surfaces.

60. Losses Incident to Storage.—There are losses incident to artificial storage that must not be overlooked; for instance, the percolation into the earth and through the embankment, evaporation from the reservoir surface and from the saturated borders, and in some instances constant draught of the share of riparian owners.

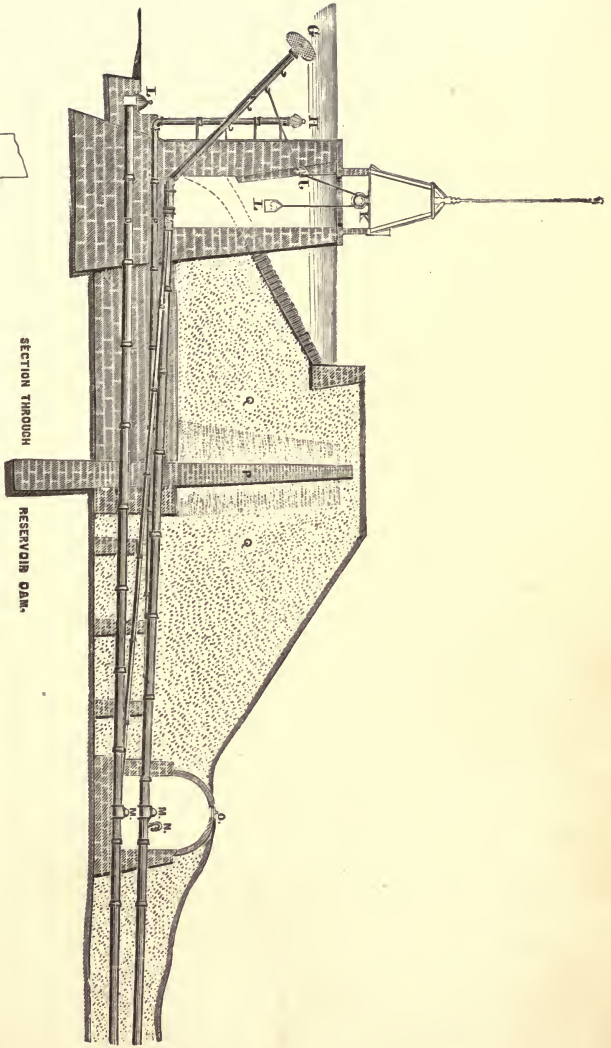

SECTION THROUGH
RESERVOIR DAM.

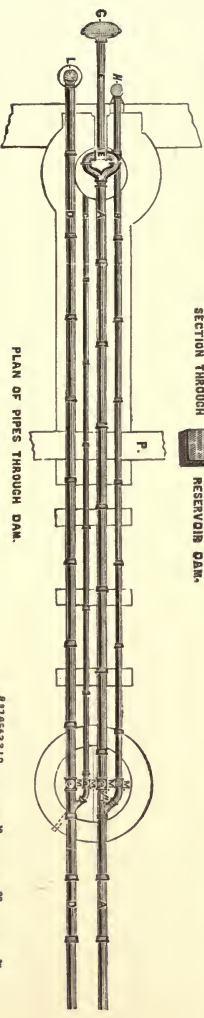

PLAN OF PIPES THROUGH DAM.

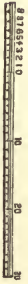

EMBANKMENT: IMPOUNDING AND DISTRIBUTING RESERVOIR, NORWICH, CONN.

61. Sub-strata of the Storage Basin.—The structure of the impounding basin, especially when the water is to fill it to great height above the old bed, is to be minutely examined, as the water at its new level may cover the edges of porous strata cropping out above the channel, or may find access to fissured rocks, either of which may lead the storage by subterranean paths along the valley and deliver it, possibly, a long distance down the stream, or in a multitude of springs beyond the impounding dam. If the water carries but little sediment of a silting nature, this trouble will be difficult to remedy, and liable to be seriously chronic.

62. Percolation from Storage Basins.—Percolation through the retaining embankment is a result of slighted or unintelligent construction, and will be discussed when constructive features are hereafter considered. (See Reservoir Embankments.)

63. Rights of Riparian Owners.—The rights of riparian owners, ancient as the riparian settlements, to the use of the water that flows, and its most favored piscatory produce, is often as a thorn in the impounder's side. What are those rights? The Courts and Legislatures of the manufacturing States have wrestled with this question, their judges have grown hoary while they pondered it, and their attorneys have prospered, and yet who shall say what riparian rights shall be, until the Court has considered all anew.

Beloe mentions* that it is a "common (British) rule in the manufacturing districts to deduct one-sixth the average rainfall for loss by floods, in addition to the absorption and evaporation, and then allow one-third of the remainder to

* Beloe on Reservoirs, p. 12. London, 1872.

the riparian owners, leaving two-thirds to the impounders. In some instances this is varied to the proportion of one-quarter to the former and three-quarters to the latter.”

The question can only be settled equitably upon the basis of daily gaugings of flow, through a long series of years. A theoretical consideration involves a thorough investigation of its geological, physical, and meteorological features. There is no more constancy in natural flow at any season than in the density of the thermometer's mercury. The flow increases as the storms are gathered into the channel, it decreases when the bow has appeared in the heavens; it increases when the moist clouds sweep low in the valleys, it decreases under the noonday sun; it increases when the shadows of evening fall across the banks, it decreases when the sharp frosts congeal the streams among the hills.

64. Periodical Classification of Riparian Rights.

—The riparian rights subject to curtailment by storage might be classified by periods not greater than monthly, though this is rarely desirable for either party in interest, but they should be based upon the most reliable statistics of monthly rainfall, evaporation, and flow, as analyzed and applied with disciplined judgment to the particular locality in question.

65. Compensations.—In the absence of local statistics of flow, it may become necessary, in settling questions of riparian rights, or adjusting compensation therefor, to estimate the periodic flow of a stream by some such method as is suggested above in the general discussion upon the flow of streams, after which it remains for the Court to fix the proportion of the flow that the impounders may manipulate for their own convenience in the successive seasons, and the proportion that is to be passed down the stream regularly or periodically.

EVAPORATION.

66. Loss from Reservoir by Evaporation.—Losses by evaporations from the surfaces of shallow storage reservoirs, lakes and ponds are, in many localities, so great in the summer and autumn that their areas are omitted in computations of water derivable from their watersheds. This is a safe practice in dry, warm climates, in which the evaporations from shallow ponds may nearly or quite equal the volume of rain that falls directly into the ponds. Marshy margins of ponds are profligate dispensers of vapor to the atmosphere, usually exceeding in this respect the water surfaces themselves.

67. Evaporation Phenomena.—Evaporation is the most fickle of all the meteorological phenomena, and its action is so subtle that we cannot observe its processes. Its results demonstrate that the constituents of water are constantly changing their state of existence from that of gas to liquid, liquid to gas, liquid to solid, and solid to gas. The action takes place as well upon polar ice fields or mountain snows, as upon tropical lagoons, though less in degree. The active vapors that form within the waters or porous ice, silently emerge through their surfaces and proceed upon their ethereal mission, and are not again recognizable until they have been once more united into cloud and condensed into rain.

The rapidity with which water, snow, and ice are converted into vapor and pass off by evaporation is dependent upon the temperature of the water and atmosphere, but more especially upon their relative temperatures, and upon the dryness and activity of the atmosphere. The formation of vapor in a body of water is supposed to be at its minimum when the atmosphere is moist and the atmosphere

and water are quiet and of an equal low temperature, and most active when the atmosphere is dryest and hottest and the wind brisk and water warm.

M. Aimé Drian observed that "when the temperature of the dew point is higher than that of the evaporating surface, water is deposited on that surface," which action he styles *negative evaporation*.

Undoubtedly the cool surfaces of deep waters condense moisture in summer from warm moist atmospheres wafted across them, and thus at times are gaining in volume while popularly supposed to be losing by evaporation. When winds blow briskly across a water surface, large volumes of unsaturated air are presented in rapid succession to attract its vapors, and the wave motion increases the agitation of the body and permits its vapors to escape freely.

The atmosphere has, however, its limit of power to absorb vapor for each given temperature, and when it is fully saturated it can receive no more without depositing an equal amount, or until its temperature is raised.

68. Evaporation from Water.—In an instructive paper upon rainfall and evaporation, by Mr. A. Golding, State Engineer at Copenhagen, quoted* by Beardmore, we find some valuable measurements of evaporation in the different seasons, from which the following, relating to evaporation at Emdrup, is extracted.

* Vide Beardmore's Hydrology, p. 269 d. London, 1862.

TABLE No. 24.

EVAPORATION FROM WATER AT EMDRUP, DENMARK.

N. Lat. 55°41'' ; E. Long 12°34'' from Greenwich.

YEAR.	Jan.	Feb.	Mar.	Apr.	May.	June.	July.	Aug.	Sept.	Oct.	Nov.	Dec.	Total.
	<i>In.</i>	<i>In.</i>	<i>In.</i>	<i>In.</i>	<i>In.</i>	<i>In.</i>	<i>In.</i>	<i>In.</i>	<i>In.</i>	<i>In.</i>	<i>In.</i>	<i>In.</i>	<i>In.</i>
1849	1.1	0.3	1.8	2.5	4.1	5.8	4.7	4.0	2.6	1.1	0.9	0.6	29.5
1850	1.1	0.3	1.2	1.7	4.5	5.6	4.8	4.8	2.4	1.6	0.9	0.2	29.1
1851	0.5	0.4	0.7	1.7	4.2	4.8	5.7	5.1	2.7	1.5	0.6	0.5	28.4
1852	0.7	0.5	0.8	2.4	3.8	4.6	6.4	4.5	2.7	1.7	0.8	0.5	29.4
1853	0.5	0.1	0.7	1.0	4.1	6.2	5.1	4.2	2.8	1.1	0.6	0.5	26.9
1854	0.5	0.9	0.9	3.2	3.3	4.5	5.2	4.3	2.6	1.2	0.7	0.6	27.9
1855	1.0	1.1	0.5	1.2	2.6	4.1	4.7	4.1	2.8	1.4	0.9	0.7	25.1
1856	0.5	0.5	1.2	2.1	2.8	4.6	4.3	4.0	2.0	0.9	0.6	0.5	24.0
1857	0.7	0.6	0.6	1.4	4.1	6.6	5.9	4.3	3.2	1.4	0.7	0.4	29.9
1858	0.4	0.7	1.2	3.1	5.1	6.1	4.9	5.6	2.8	1.6	0.7	0.4	30.6
1859	0.3	0.5	0.7	1.9	4.3	5.8	5.3	3.8	1.8	1.0	0.7	0.3	26.4
Mean ..	0.7	0.5	0.9	2.0	3.7	5.4	5.2	4.4	2.6	1.3	0.7	0.5	27.9
Ratio ..	.301	.215	.387	.860	1.592	2.323	2.237	1.892	1.118	.559	.301	.215

Mean Evaporation from Short Grass, 1852 to 1859 inclusive.

Mean ..	0.7	0.8	1.2	2.6	4.1	5.5	5.2	4.7	2.8	1.3	0.7	0.5	30.1
---------	-----	-----	-----	-----	-----	-----	-----	-----	-----	-----	-----	-----	------

Mean Evaporation from Long Grass, 1849 to 1856 inclusive.

Mean ..	0.9	0.6	1.4	2.6	4.7	6.7	9.3	7.9	5.2	2.9	1.3	0.5	44.0
---------	-----	-----	-----	-----	-----	-----	-----	-----	-----	-----	-----	-----	------

Mean Rainfall at same Station, 1848 to 1859 inclusive.

Mean ..	1.5	1.7	1.0	1.6	1.5	2.2	2.4	2.4	2.0	2.3	1.8	1.5	21.9
---------	-----	-----	-----	-----	-----	-----	-----	-----	-----	-----	-----	-----	------

TABLE No. 25.

69. Evaporation from Earth.—MEAN EVAPORATION FROM EARTH, AT BOLTON LE MOORS,* LANCASHIRE, ENG., 1844 TO 1853, INCLUSIVE.

Lat. 53°30'' N.; Height above the Sea, 320 Feet.

	Jan.	Feb.	Mar.	Apr.	May.	June.	July.	Aug.	Sept.	Oct.	Nov.	Dec.	Total.
Mean ..	0.64	0.95	1.59	2.59	4.38	3.84	4.02	3.06	2.02	1.28	0.81	0.47	25.65
Ratio...	.299	.444	.739	1.212	2.049	1.796	1.887	1.431	.945	.599	.379	.220

Mean Rainfall at same Station, 1844 to 1853 inclusive.

Mean ..	4.63	4.03	2.25	2.22	2.23	4.07	4.32	4.77	3.79	5.07	4.64	3.94	45.96
---------	------	------	------	------	------	------	------	------	------	------	------	------	-------

* Beardmore's Hydrology, p. 325.

MEAN EVAPORATION FROM EARTH, AT WHITEHAVEN, CUMBERLAND,
ENG., 1844 TO 1853 INCLUSIVE.

Lat. 54° 30' N.; Height above the Sea, 90 feet.

	Jan.	Feb.	Mar.	Apr.	May.	June.	July.	Aug.	Sept.	Oct.	Nov.	Dec.	Total.
Mean. Ratio ..	0.95 .390	1.01 .415	1.77 .727	2.71 1.113	4.11 1.689	4.25 1.746	4.13 1.697	3.29 1.352	2.96 1.216	1.76 .723	1.25 .513	1.02 .419	29.21

Mean Rainfall at same Station, 1844 to 1853 inclusive.

Mean ..	5.1	3.4	2.5	2.2	1.9	3.1	4.3	4.3	3.1	5.3	4.5	3.8	43.5
---------	-----	-----	-----	-----	-----	-----	-----	-----	-----	-----	-----	-----	------

70. Examples of Evaporation.—Charles Greaves, Esq., conducted a series of experiments upon percolation and evaporation, at Lee Bridge, in England, continuously from 1860 to 1873, and has given the results* to the Institution of Civil Engineers. The experiments were on a large scale, and the very complete record is apparently worthy of full confidence.

The evaporation boxes were one yard square at the surface and one yard deep. Those for earth were sunk nearly flush in the ground, and that for water floated in the river Lee. The mean annual rainfall during the time was 27.7 inches. The annual evaporations from *soil* were, minimum 12.067 inches; maximum 25.141 inches; and mean 19.534 inches:—from *sand*, minimum 1.425 inches; maximum 9.102 inches; and mean 4.648 inches:—from *water*, minimum 17.332 inches; maximum 26.933 inches; and mean 22.2 inches.

Some experimental evaporators were constructed at Dijon on the Burgundy canal, and are described in *Annales des Ponts et Chaussées*. They are masonry tanks lined with zinc, eight feet square and one and one-third feet deep,

* Trans. Inst. Civil Engineers, 1876, Vol. XLV, p. 33.

and are sunk in the ground. From 1846 to 1852, there was a mean annual evaporation of 26.1 inches from their water surfaces against a rainfall of 26.9 inches. At the same time a small evaporator, one foot square, placed near the larger, gave results fifty per cent. greater.

Observations of evaporation from a water surface at the receiving reservoir in New York indicated the mean annual evaporation from 1864 to 1870 inclusive as 39.21 inches, which equaled 81 per cent. of the rainfall.

On the West Branch of the Croton River, an apparatus* was arranged for the purpose of measuring the evaporation from water surface, consisting of a box four feet square and three feet deep, sunk in the earth in an exposed situation and filled with water. The mean annual evaporation was found to be 24.15 inches, or about fifty per cent. of the rainfall. The observations were made twice a day with care. The maximum annual evaporation was 28 inches.

Evaporations from the surface of water in shallow tanks are variously reported as follows :

At Cambridge, Mass.,	one year,	56.00	inches	depth.
“ Salem, “	“ “	56.00	“	“
“ Syracuse, N. Y.,	“ “	50.20	“	“
“ Ogdensburgh, N. Y.,	“ “	49.37	“	“
“ Dorset, England,	three “	25.92	“	“
“ Oxford, “	five “	31.04	“	“
“ Demerara,	three “	35.12	“	“
“ Bombay,	five “	82.28	“	“

71. Ratios of Evaporation.—In the eastern and middle United States, the evaporation from storage reservoirs, having an average depth of at least ten feet, will rarely exceed sixty per cent. of the rainfall upon their surface.

* *Vide* paper on “Flow of the West Branch of the Croton River,” by J. Jas. R. Croes. Trans. Am. Soc. Civ. Engrs., July, 1874, p. 83.

The ratio of evaporation in each month to the monthly average evaporation, or one-twelfth the annual depth, is estimated to be, for an average, approximately as follows :

TABLE No. 26.
MONTHLY RATIOS OF EVAPORATION FROM RESERVOIRS.

	Jan.	Feb.	Mar.	Apr.	May.	June.	July.	Aug.	Sept.	Oct.	Nov.	Dec.
Mean ratio....	.30	.35	.50	.80	1.45	1.70	1.85	2.00	1.45	.75	.50	.35

The following ratios of the annual evaporation from water surfaces are equivalent to the above monthly ratios, and may be used as multipliers directly into the annual evaporation to compute an equivalent depth of rain in inches upon the given surface in action. Beneath the ratios are given the equivalent depths for each month of 40 inches annual rain, assuming the annual evaporation to equal sixty per cent. of the rainfall, or 24 inches depth.

TABLE No. 27.
MULTIPLIERS FOR EQUIVALENT INCHES OF RAIN EVAPORATED.

	Jan.	Feb.	Mar.	Apr.	May.	June.	July.	Aug.	Sept.	Oct.	Nov.	Dec.	Total.
Ratio of annual evaporation.....	.0250	.0292	.0417	.0667	.1208	.1417	.1542	.1667	.1208	.0625	.0417	.0292	
Equivalent depth of rain —inches.....	.6	.7	1.0	1.6	2.9	3.4	3.7	4.	2.9	1.5	1.0	.7	24.77.

72. Resultant Effect of Rain and Evaporation.—

For the purpose of comparing the effects upon a reservoir replenished by rain only, let us assume the available rainfall to be eight-tenths of 40 inches per annum, and the ratios of mean monthly rain, and the ratios of annual rain in inches depth, to be as per the following table :

	Jan.	Feb.	Mar.	Apr.	May.	June.	July.	Aug.	Sept.	Oct.	Nov.	Dec.
Ratio of aver. monthly rain	.75	.83	.90	1.10	1.30	1.08	1.12	1.20	1.00	.95	.93	.84
Ratio of .8 of annual rain.	.0625	.0692	.0750	.0917	.1083	.0900	.0933	.1000	.0833	.0792	.0775	.0700
Equiv. inches of rain.....	2.00	2.21	2.40	2.93	3.47	2.88	2.99	3.20	2.67	2.53	2.48	2.24

Comparing, in the two last tables, and their lowest columns, the inches of gain by rainfall upon the reservoir, supposing the sides of the reservoir to be perpendicular, and the inches of loss from the same reservoir by evaporation, we note that the gain preponderates until June, then the loss preponderates until in November.

73. Practical Effect upon Storage.—Since the practical value of storage is ordinarily realized between May and November, the excess of loss during that term is, practically considered, the annual deficiency from the reservoir chargeable to evaporation. We compute its maximum in the following table, commencing the summation in June, all the quantities being in inches depth of rain.

	Jan.	Feb.	Mar.	Apr.	May.	June.	July.	Aug.	Sept.	Oct.	Nov.	Dec.	Total.
Gain by rain— inches	2.00	2.21	2.40	2.93	3.47	2.88	2.99	3.20	2.67	2.53	2.48	2.24	32
Loss by evaporation— inches60	.70	1.00	1.60	2.90	3.40	3.70	4.00	2.90	1.50	1.00	0.70	24
Difference— inches	+1.40	+1.51	+1.40	+1.33	+0.57	-0.62	-0.71	-0.80	-0.23	+0.97	+1.48	+1.54	..
Max. deficiency after June— inches	-0.62	-1.33	-2.13	-2.36	-1.39	+0.09

If the classification is reduced to daily periods instead of monthly, the maximum deficiency, according to the above basis, will in a majority of years exceed three inches.

CHAPTER VI.

SUPPLYING CAPACITY OF WATERSHEDS.

74. Estimate of Available Annual Flow of Streams.

—Applying our calculations in the last chapter, of available flow of water from the unit of watershed, one square mile, and modifying it by the elements of compensation, storage, evaporation, and percolation, we then estimate mean annual quantities of low-cycle years, applicable to domestic consumption, as follows:

Assumed mean annual rainfall..... 40 inches.
 Flow of stream available for storage, 40 per cent. of mean rain = 16 inches of rain.

This available rain is applied to:

1st. Compensation to riparian owners,		say 16.8 p. c. of mean rain = 6.72 in. of rain.
2d. Evaporation from surface of storage reservoir,	" 2.4 " " " "	= .96 " " "
3d. Percolation from storage reservoir,	" 2.4 " " " "	= .96 " " "
4th. Balance available for consumption,	18.4 " " " "	= 7.36 " " "
Total.....	40 per cent.	16 inches.

The 7.36 inches of rain estimated as available from a 40-inch annual rain equals 17,098,762 cubic feet of water, which is equivalent to a continuous supply of seven cubic feet per day (= 52.36 gals.) each, to 6,692 persons.

By applying to the annual results the monthly ratios, and thus developing the monthly surpluses or deficiencies of flow, we shall have in the algebraic sum of the deficiencies the volume of storage necessary to make forty per cent. of the rainfall available, and this storage must ordinarily approximate one-third of the annual flow available for storage.

75. Estimate of Monthly Available Storage Required.—Computation of a supply, and the required storage; applied to one square mile of watershed as a unit of area.

Assumed data: Population to be supplied, 6,500 persons, consuming 7 cubic feet per capita daily, each;

Mean annual rainfall, 40 inches, and eight-tenths = 32 inches of rain, in the low-cycle years;

Available flow of stream, fifty per cent. of eight-tenths of rain = 16 inches;

Compensation each month, .168 of one-twelfth the mean annual depth of rain = .56 inches each month uniformly;

Evaporation annually from the reservoir surface, only, sixty per cent. of the depth of mean annual rain, or 24 inches; and monthly, sixty per cent. of one-twelfth the annual evaporation = 2 inches.

Area of storage reservoir, .04 square mile,* or 25.6 acres, with equivalent available draught of ten feet for that surface. The evaporation of two inches from four hundredths of a square mile = .08 inch from one square mile.

Volume of percolation assumed to equal volume of evaporation from the reservoir surface.

The monthly ratios will be multiplied into

$$\frac{40 \text{ in.} \times .8 \times .50 \text{ p. c.}}{12 \text{ months}} = 1.3333 \text{ in. for the monthly flow.}$$

$$\frac{40 \text{ in. mean rain}}{12 \text{ months}} = 3.3333 \text{ in. for monthly compensation.}$$

$$.04 \times \frac{40 \text{ in.} \times 60 \text{ p. c.}}{12 \text{ months}} = .08 \text{ in. for monthly evaporation from reservoir.}$$

$$\text{“} \quad \quad \quad = .08 \text{ in. for monthly percolation from reservoir.}$$

$$6500 \times 7 \text{ cu. ft.} \times 30.4369 \text{ days} = 1,384,879 \text{ cu. ft. for monthly consumption.}$$

* A unit of reservoir area, for each square mile *unit* of watershed.

TABLE No. 28.
MONTHLY SUPPLY TO, AND DRAFT FROM, A STORAGE RESERVOIR.

MONTH.	MONTHLY FLOW. <i>cubic feet.</i>	MONTHLY COMPEN- SATION. <i>cubic feet.</i>	MONTHLY EVAPORA- TION FROM RESER- VOIR. <i>cubic feet.</i>	MONTHLY PERCOLA- TION FROM RESER- VOIR. <i>cubic feet.</i>	MONTHLY DOMESTIC CONSUMPTION. <i>cubic feet.</i>	SURPLUS. <i>cubic feet.</i>	DEFICIENCY. <i>cubic feet.</i>
	<i>Gain.</i>	<i>Loss.</i>	<i>Loss.</i>	<i>Loss.</i>	<i>Used.</i>		
Jan. {	Ratio, 1.65 5,111,040	Ratio, .168 1,300,992	Ratio, .30 55,757	Ratio, .30 55,757	Ratio, 1.05 1,454,123	2,311,507
Feb. {	Ratio, 1.50 4,646,400	.168 1,300,992	.35 65,050	.35 65,050	1.10 1,523,367	1,691,941
Mar. {	Ratio, 1.65 5,111,040	.168 1,300,992	.50 92,928	.50 92,928	.90 1,246,391	2,447,497
Apr. {	Ratio, 1.45 4,490,746	.168 1,300,992	.80 148,685	.80 148,685	.85 1,177,147	1,715,237
May {	Ratio, .85 2,632,186	.168 1,300,992	1.45 269,491	1.45 269,491	.90 1,246,391	454,119
June {	Ratio, .75 2,323,200	.168 1,300,992	1.70 315,955	1.70 315,955	1.00 1,384,879	994,581
July {	Ratio, .35 1,084,934	.168 1,300,992	1.85 343,834	1.85 343,834	1.20 1,661,855	2,565,581
Aug. {	Ratio, .25 773,626	.168 1,300,992	2.00 371,712	2.00 371,712	1.25 1,731,099	3,037,889
Sept. {	Ratio, .30 929,280	.168 1,300,992	1.45 269,491	1.45 269,491	1.05 1,454,123	2,364,817
Oct. {	Ratio, .45 1,393,920	.168 1,300,992	.75 139,392	.75 139,392	.90 1,246,391	1,432,247
Nov. {	Ratio, 1.20 3,717,120	.168 1,300,992	.50 92,928	.50 92,928	.85 1,177,147	1,053,125
Dec. {	Ratio, 1.60 4,955,386	.168 1,300,992	.35 65,050	.35 65,050	.95 1,315,635	2,208,659
Totals	37,272,270	15,611,904	2,232,072	2,232,072	16,618,548	11,427,966	10,849,234

From certain localities no claim will arise for diversion of the water, or the diversion may be compensated for by the payment of a cash bonus, in which case the proportion of rainfall applicable to domestic consumption will be a little more than doubled, and approximately as follows, neglecting percolation from the storage reservoir.

The monthly ratios will here be multiplied into

$$\frac{40 \text{ in.} \times .8 \times .50 \text{ p. c.}}{12 \text{ months}} = 1.3333 \text{ in. for the monthly flow.}$$

$$.04 \times \frac{40 \text{ in.} \times .60 \text{ p. c.}}{12 \text{ months}} = .08 \text{ in. for monthly evaporation from reservoir.}$$

$$13,500 \text{ persons} \times 7 \text{ cu. ft.} \times 30.4369 \text{ days} = 2,876,467 \text{ cu. ft. for monthly consumption.}$$

TABLE No. 29.

MONTHLY SUPPLY TO, AND DRAFT FROM, A STORAGE RESERVOIR
(without compensation).

MONTH.	MONTHLY FLOW. <i>cubic feet.</i>	MONTHLY EVAPORATION FROM RESERVOIR. <i>cubic feet.</i>	MONTHLY DOMESTIC CONSUMPTION. <i>cubic feet.</i>	SURPLUS. <i>cubic feet.</i>	DEFICIENCY. <i>cubic feet.</i>
	<i>Gain.</i>	<i>Loss.</i>	<i>Used.</i>		
Jan.	Ratio, 1.65 5,180,736	Ratio, .30 57,557	Ratio, 1.05 3,020,290	2,102,889
Feb.	Ratio, 1.50 4,646,400	.35 65,050	1.10 3,164,114	1,417,236
Mar.	Ratio, 1.65 5,180,736	.50 92,928	.90 2,588,820	2,498,988
April	Ratio, 1.45 4,490,746	.80 148,685	.85 2,444,997	1,897,064
May	Ratio, .85 2,632,186	1.45 269,491	.90 2,588,820	226,125
June	Ratio, .75 2,323,200	1.70 315,955	1.00 2,876,467	869,222
July	Ratio, .35 1,084,934	1.85 343,834	1.20 3,451,760	2,710,660
Aug.	Ratio, .25 737,626	2.00 371,712	1.25 3,595,584	3,229,670
Sept.	Ratio, .30 929,280	1.45 269,491	1.05 3,020,290	2,360,501
Oct.	Ratio, .45 1,393,920	.75 139,392	.90 2,588,820	1,334,292
Nov.	Ratio, 1.20 3,717,120	.50 92,928	.85 2,444,997	1,179,195
Dec.	Ratio, 1.60 4,955,386	.35 65,050	.95 2,732,644	2,157,692
Totals,	37,272,270	2,232,072	34,517,603	11,253,064	10,730,470

76. Additional Storage Required.—Forty inches of rainfall on one square mile equals a volume of 92,928,000 cubic feet. The deficiency as above computed is nearly twelve per cent. of this quantity, and calls for an available volume of water in store early in May, or at the beginning of a drought, equal to about one-eighth the mean annual rainfall.

The calculations of supply and draught in the two monthly tables given above refer to mean quantities of low-cycle years, and not to extreme minimums. The seasons of minimum flow, which are also, usually, the seasons of maximum evaporation from the storage reservoirs and of maximum domestic consumption, are in the calculations supposed to be tided over by a surplus of storage provided in addition to the mean storage required for the series of low-cycle years. The storage should therefore be in excess of the mean deficiency as above computed at least twenty-five per cent., or should equal at least fifteen per cent. of the mean annual rainfall.

If the storage is less than fifteen per cent., the safe available supply is liable to be less than the calculations given.

If the area of the storage reservoir is greater per square mile of watershed than assumed above, the loss by evaporation from the water surface will be proportionately increased, and must be compensated for by increased storage.

77. Utilization of Flood Flows.—The calculations as above assume that fifty per cent. of the annual rainfall is the available annual flow in the stream. The remaining fifty per cent. is assumed to be lost through the various processes of nature and by floods. If the storage is still further increased, an additional portion of the flood flow can be utilized, and sometimes fifty per cent. or even sixty

per cent. of the annual rainfall utilized for domestic consumption, or made applicable at the outlet of the reservoir for power. Hence, when it is desired to utilize the greatest possible portion of the flow, the storage should equal twenty or twenty-five per cent. of the mean annual rainfall.

78. Qualification of Deduced Ratios.—The ratios of flow, evaporation, and consumption, as above used in the calculations, are not assumed to be universally applicable, but are taken as safe general average ratios for the Atlantic Coast and Middle States. The winter consumption will be less in the lower Middle and Southern States, and also in very efficiently managed works of Northern States; but the summer consumption tends to be greater in the lower Middle and Southern States, where the evaporation and rainfall are greater also.

The results upon the Pacific slope can scarcely be generalized to any profit, since within a few hundred miles it presents extremes, from rainless desert to the maximum rainfall of the continent, and from vaporless atmosphere to constant excessive humidity.

79. Influence of Storage upon a Continuous Supply.—A safe general estimate of the maximum continuous supply of water to be obtained from forty inches of annual rain upon one square mile of watershed, provided the storage equals at least fifteen per cent. of the rainfall, gives 7 cubic feet (= 52.36 gals.) per capita daily, to from 13000 to 15000 persons, dependent upon the amount of available storage of winter and flood flows; or say, three-quarters of a million gallons of water daily.

The same area and rain, with but one month's deficiency storage, can be safely counted upon to supply but about 3,000 persons with an equal daily consumption, or 157,000 gallons of water daily. From the same area and rain, with

no storage, a flashy stream may fail to supply 1,000 persons to the full average demand in seasons of severe drought.

Hence the importance of the storage factor in the calculation.

The above estimates are based upon mean rainfalls of low-cycle (§ 47) years; therefore the results may be expected to be twenty per cent. greater in years of general average rainfall.

80. Artificial Gathering Areas.—When resort is necessarily had to impervious artificial collecting areas for a domestic water supply, as when dwellings are located upon vegetable moulds or low marsh areas, bituminous rock surfaces, limestone surfaces, or, as in Venice, where the sheltering roofs are the gathering areas of the households, the proportion of the rainfall that may be run into cisterns is very large. If such cisterns are of sufficient capacity and their waters protected from evaporation, eighty per cent. of the rainfall upon the gathering areas may thus be made available, though special provisions for its clarification will be indispensable.

In such case, a roof area equivalent to 25 feet by 100 feet might furnish from a forty-inch rainfall a continuous supply of 3 cubic feet (= 22.44 gallons) per day to six persons, which would be abundant for the household uses for that number of persons.

81. Recapitulation of Rainfall Ratios.—Recapitulating, in the form of general average annual ratios, relating to the mean rainfall upon undulating crystalline or diluvial surface strata, as unity, we have :

Ratio of mean annual rainfall.....	1.00
Ratio of mean rainfall of lowest three-year cycles.....	.80
Ratio of minimum annual rainfall.....	.70
Ratio of mean annual flow in stream (of the given year's rain).....	.60

Ratio of mean summer flow in stream (of the given year's rain).....	.25
Ratio of low summer flow in stream " " "05
Ratio of annual available flow in stream " "50
Ratio of storage necessary to make available 50 per cent. of annual rain.	.15
Ratio of general evaporation from earths, and consumption by the processes of vegetation.....	.40
Ratio of percolation through the earth (included also in the flow of streams).....	.25
Ratio of mean rainfall collectible upon impervious artificial or primary rock surfaces.....	.80

The monthly ratios of these annual ratios are to be taken in ordinary calculations of water supplies, and each annual ratio to be subjected to the proper modification adapting it to a special local application.

TABLE No. 30.

RATIOS OF MONTHLY RAIN, FLOW, EVAPORATION, AND CONSUMPTION.

	Jan.	Feb.	Mar.	Apr.	May.	June.	July.	Aug.	Sept.	Oct.	Nov.	Dec.
Ratios of average monthly rain.....	.75	.83	.90	1.10	1.30	1.68	1.12	1.20	1.00	.95	.93	.84
Ratios of av. monthly flow of streams.	1.65	1.50	1.65	1.45	.83	.75	.35	.25	.30	.45	1.20	1.60
Ratios of av. monthly evap. from water	.30	.35	.50	.80	1.45	1.70	1.85	2.00	1.45	.75	.50	.35
Ratios of average monthly consumption of water.....	1.05	1.10	.90	.85	.90	1.00	1.20	1.25	1.05	.90	.85	.95

CHAPTER VII.

SPRINGS AND WELLS.

82. Subterranean Waters.—A portion of the rain, perhaps one-fourth part of the whole, distilled upon the surface of the earth, penetrates its soils, the interstices of the porous strata, the crevices of the rocks, and is gathered in the hidden recesses. These subterranean reservoirs were filled in the unexplored past, and their flow continues in the present as they are replenished by new rainfalls.

83. Their Source the Atmosphere.—We find no reason to suppose that Nature duplicates her laboratory of the atmosphere in the hidden recesses of the earth, from whence to decant the sparkling springs that issue along the valleys. On the other hand, we are often able to trace the course of the waters from the storm-clouds, into and through the earth until they issue again as plashing fountains and flow down to the ocean.

The clouds are the immediate and only source of supply to the subterranean watercourses, as they are to the surface streams we have just passed in review.

The subterranean supplies are subject indirectly to atmospheric phenomena, temperatures of the seasons, surface evaporations, varying rainfalls, physical features of the surface, and porosity of the soils. Especially are the shallow wells and springs sensitively subject to these influences.

84. Porosity of Earths and Rocks.—Respecting the porosity and absorptive qualities of different earths, it may be observed that clean silicious sand, when thrown loosely together, has voids between its particles equal to nearly

FIG. 131.

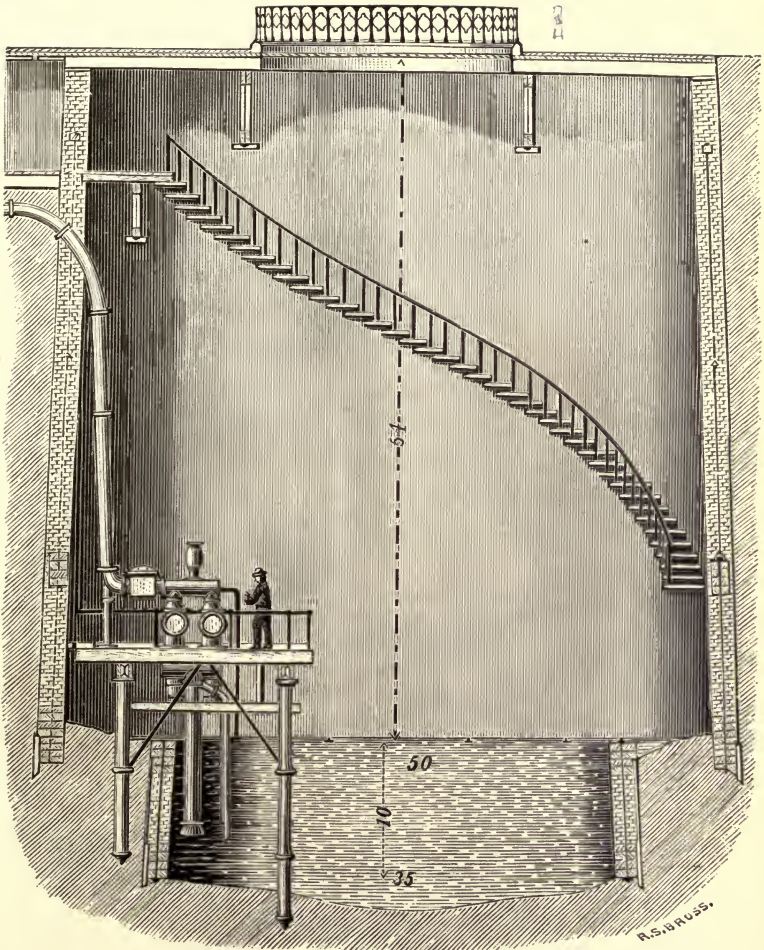

INTERCEPTING WELL, PROSPECT PARK, BROOKLYN.



one-third its volume of cubical measure ; that is, if a tank of one cubic yard capacity is filled with quartzoid sand, then from thirty-to thirty-five per cent. of a cubic yard of water can be poured into the tank with the sand without overflowing.

Gravel, consisting of small water-worn stones or pebbles, intermixed with grains of sand, has ordinarily twenty to twenty-five per cent. of voids.

Marl, consisting of limestone grains, clays, and silicious sands, has from ten to twenty per cent. of voids, according to the proportions and thoroughness of admixture of its constituents.

Pure clays have innumerable interstices, not easily measured, but capable of absorbing, after thorough drying, from eight to fifteen per cent. of an equal volume of water.

The water contained in clays is so fully subject to laws of molecular attraction, owing to the minuteness of the individual interstices, that great pressure is required to give it appreciable flow.

Water flows with some degree of freedom through sandstones, limestones, and chalks, according to their textures, and they are capable of absorbing from ten to twenty per cent. of their equal volumes of water.

The primary and secondary formations, according to geological classification, as for instance, granites, serpentines, trappeans, gneisses, mica-slates, and argillaceous schists, are classed as impervious rocks, as are, usually, the several strata of pure clays that have been subjected to great superincumbent weight.

The crevices in the impervious rocks, resulting from rupture, may, however, gather and lead away, as natural drains, large volumes of the water of percolation.

The free flow of the percolating water toward wells or

spring, is limited and controlled, not only by the porosity of the strata which it enters, but also by their inclination, curvature, and continuous extent, and by the imperviousness of the underlying stratum, or plutonic rock.

85. Percolations in the Upper Strata.—*Shallow well and spring* supplies are, usually, yields of water from the drift formation alone. Their temperatures may be variable, rising and falling gradually with the mean temperatures of the surface soils in the circuits of the seasons, and they may not be wholly freed from the influence of the decomposed organic surface soils. Their flow is abundant when evaporation upon the surface is light, though slackened when the surface is sealed by frost.

A variable spring, and it is the stream at its issue that we term a spring, indicates, usually, a flow from a shallow, porous surface stratum, say, not exceeding 50 feet in depth, though occasionally its variableness is due to peculiar causes, as the melting of glaciers in elevated regions, and atmospheric pressure upon sources of intermittent springs.

Porous strata of one hundred feet in depth or more give comparatively uniform flow and temperature to springs.

86. The Courses of Percolation.—Gravitation tends to draw the particles of water that enter the earth directly toward the center of the earth, and they percolate in that direction until they meet an impervious strata, as clay, when they are forced to change their direction and follow along the impervious surface toward an outlet in a valley, and possibly to find an exit beneath a lake or the ocean.

When the underlying impervious strata has considerable average depth, it may have been unevenly deposited in consequence of eddies in the depositing stream, or crowded into ridges by floating icebergs, or it may have been worn into valleys by flowing water. Subsequent deposits of

sand and gravel would tend to fill up the concavities and to even the new surface, hiding the irregularities of the lower strata surface.

The irregularities of the impervious surface would not be concealed from the percolating waters, and their flow would obey the rigid laws of gravitation as unswervingly as do the showers upon the surface, that gather in the channels of the rocky hills.

Springs will appear where such subterranean channels intercept the surface valleys. The magnitude of a spring will be a measure of the magnitude of its subterranean gathering valley.

87. Deep Percolations.—The *deep flow* supplies of wells and springs are derived, usually, from the older porous stratifications lying below the drift and recent clays. The stratified rocks yielding such supplies have in most instances been disturbed since their original depositions, and they are found inclined, bent, or contorted, and sometimes rent asunder with many fissures, and often intercepted by dykes.

88. Subterranean Reservoirs.—Subterranean basins store up the waters of the great rain percolations and deliver them to the springs or wells in constant flow, as surface lakes gather the floods and feed the streams with even, continuous delivery. A concave dip of a porous stratum lying between two impervious strata presents favorable conditions for an “artesian” well, especially if the porous stratum reaches the surface in a broad, concentric plane of great circumference, around the dip, forming an extensive gathering area.

Waters are sometimes gathered through inclined strata from very distant watersheds, and sometimes their course

leads under considerable hills of more recent deposit than the stratum in which the water is flowing.

The chalks and limestones do not admit of free percolation, and are unreliable as conveyers of water from distant gathering surfaces, since their numerous fissures, through which the water takes its course, are neither continuous nor uniform in direction.

89. The Uncertainties of Subterranean Searches.

—The conditions of the abundant saturation and scanty saturation of the strata, and their abilities to supply water continuously, are very varied, and may change from the first to the second, and even alternate, with no surface indications of such result; and the subterranean flow may, in many localities, be in directions entirely at variance with the surface slopes and flow.

Predictions of an ample supply of water from a given subterranean source are always extremely hazardous, until a thorough knowledge is obtained of the geological positions, thickness, porosity, dip, and soundness of the strata, over all the extent that can have influence upon the flow at the proposed shaft.

Experience demonstrates that water may be obtained in liberal quantity at one point in a stratum, while a few rods distant no water is obtainable in the same stratum, an intervening "fault" or crevice having intercepted the flow and led it in another direction. Sometimes, by the extension of a heading from a shaft in a water-bearing stratum, to increase an existing supply, a fault is pierced and the existing supply led off into a new channel.

90. Renowned Application of Geological Science.

—Arago's prediction of a store of potable water in the deep-dipping greensand stratum beneath the city of Paris, was one of the most brilliant applications of geological science

to useful purposes. He felt keenly that a multitude of his fellow-citizens were suffering a general physical deterioration for want of wholesome water, for which the splendors of the magnificent capital were no antidote. With a foresight and energy, such as displays that kind of genius that Cicero believed to be "in some degree inspired," he prevailed upon the public Minister to inaugurate, in the year 1833, that notable deep subterranean exploration at Grenelle. By his eloquent persuasions he maintained and defended the enterprise, notwithstanding the eight years of labor to successful issue were beset with discouragements, and all manner of sarcasms were showered upon the promoters. In February, 1841, the augur, cutting an eight-inch bore, reached a depth of 1806 feet 9 inches, when it suddenly fell eighteen inches, and a whizzing sound announced that a stream of water was rising, and the well soon overflowed.

91. Conditions of Overflowing Wells.—An overflow results only when the surface that supplies the water-bearing stratum is at an elevation superior to the surface of the ground where the well is located, and the water-bearing stratum is confined between impervious strata. In such case, the hydrostatic pressure from the higher source forces the water up to the mouth of the bore.

92. Influence of Wells upon Each Other.—The success of wells, penetrating deep into large subterranean basins, upon their first completion, has usually led to their duplication at other points within the same basin, and the flow of the first has often been materially checked upon the commencement of flow in the second, and both again upon the commencement of flow in a third, though neither was within one mile of either of the others. The flow of the famous well at Grenelle was seriously checked by the open-

ing of another well at more than 3000 yards, or nearly two miles distant.

The successful sinking of deep wells in Europe began at Artois, in France, in the year 1126. The name "Artesian," from the name of the province of Artois, has been familiarly associated with such wells from that date, notwithstanding similar works were executed among the older nations many years earlier. Since the success at Artois, this method has been adopted in many towns of France, England, and Germany, where the geological structure admitted of success. The French engineers have recently sunk nearly one hundred successful wells in the great Desert of Sahara; and Algeria and Northern Africa are beginning to bloom in waste places in consequence of being watered by the precious liquid sought in the depths of the earth.

93. American Artesian Wells.—Not less than 21 yielding wells have been sunk in Chicago varying in depth from 1200 to 1640 feet, the most successful of which is five and one half inches diameter at the bottom, yielding about 900,000 gallons of water per 24 hours. The usual depth of the Chicago wells is reported to be from 1200 to 1300 feet, and the average cost of a five-and-a-half-inch well \$6000, and for a four-and-a-half-inch well \$5000, for depth of 1200 feet.

A well for the Insane Asylum at St. Louis has reached a depth of 3850 feet, or 3000 feet below the level of the sea.

Along the line of the Union Pacific Railroad, water is obtained at certain points by means of Artesian wells, for supplying the necessities of the road.

A few Artesian wells have been sunk in Boston, but the water obtained has rarely been of satisfactory quality for domestic purposes.

94. Watersheds of Wells.—The watershed of a deep subterranean supply is not so readily distinguishable as is

that of a surface stream, that usually has its limit upon the crown of the ridge sweeping around its upper area.

The subterranean watershed may possibly lie in part beyond the crowning ridge, where its form is usually that of a concentric belt, of varying width and of varying surface inclination. A careful examination of the position, nature, and dip of the strata only, can lead to an accurate trace of its outlines.

The granular structure of the water-bearing stratum, as a vehicle for the transmission of the percolating water, is to be most carefully studied; the existence of faults that may divert the flow of percolation are to be diligently sought for; and the point of lowest dip in a concave subterranean basin or the lowest channel line of a valley-like subterranean formation, is to be determined with care.

A depressed subterranean water basin, when first discovered, is invariably full to its lip or point of overflow. Its extent may be comparatively large, and its watershed comparatively small, yet it will be full, and many centuries may have elapsed since it was moulded and first began to store the precious showers of heaven. A few drops accumulated from each of the thousand showers of each decade, may have filled it to its brim many generations since; yet this is no evidence that it is inexhaustible. If the perennial draught exceeds the amount the storms give to its replenishment, it will surely cease, in time, to yield the surplus.

Coarse sands will, when fully exposed, absorb the greater portion of the showers, but such sands are usually covered with more or less vegetable soil, except in regions where showers seldom fall.

Fissured limestones and chalks will also absorb a large portion of the storms, if exposed, but they are rarely entirely uncovered except upon steep cliff faces, where there

is little opportunity for the storms that drive against them to secure lodgement.

95. Evaporation from Soils.—Vegetable and surface soils that do not permit free percolation of their waters downward to a depth of at least three feet, lose a part of it by evaporation. On the other hand, evaporation opens the surface pores of close soils, so that they receive a portion of the rain freely.

96. Supplying Capacity of Wells and Springs.—Percolation in ordinary soils takes place in greatest part in the early spring and late autumn months, and to a limited extent in the hot months. In cold climates it ceases almost entirely when the earth is encased with frost.

Permanent subterranean well or spring supplies receive rarely more than a very small share of their yearly replenishment between each May and October, their continuous flow being dependent upon adequate subterranean storage.

Such storage may be due to collections in broad basins, to collections in numerous fissures in the rocks, or to very gradual flow long distances through a porous stratum where it is subject to all the limiting effects of retardation included under the general term, friction.

In the latter case a great volume of earth is saturated, and a great volume of water is in course of transmission, and the flow continues but slightly diminished until after a drought upon the surface is over and the parched surface soils are again saturated and filling the interstices of percolation anew.

For an approximate computation of the volume of percolation into one square mile of porous gathering area, covered with the ordinary superficial layer of vegetable soil, and under usual favorable conditions generally, let us assume that the mean annual rainfall is 40 inches in depth,

and that in the seasons of droughts, or the so-called dry years, 60 per cent. of the mean monthly percolation will take place.

TABLE No. 31.

PERCOLATION OF RAIN INTO ONE SQUARE MILE OF POROUS SOIL.

Assumed Mean Annual Rain 40 Inches Depth.

	Jan.	Feb.	Mar.	Apr.	May.	June.	July.	Aug.	Sept.	Oct.	Nov.	Dec.	Total
Ratios of $\frac{1}{12}$ of mean annual rain.....	.737	.796	1.070	.814	1.462	.964	1.077	1.251	1.015	1.076	.937	.801	
Inches of rain each month.....	2.457	2.653	3.567	2.713	4.873	3.213	3.590	4.170	3.383	3.587	3.123	2.670	40
Ratios of Percolation... Mean inches of Rain Percolating.....	1.228	1.061	1.605	.407	.268	.064	.036	.021	.034	.717	1.561	1.869	
Sixty per cent. of do. in dry years.....	.737	.637	.963	.244	.167	.038	.022	.013	.020	.430	.937	1.121	
Volume of Percolation in dry years. <i>Ch. Feet.</i>	1,712,198	1,479,878	2,237,242	566,861	387,974	88,282	51,110	30,202	46,464	989,976	2,176,838	2,604,397	
No. of persons it would supply at 5 cu. ft. each daily.....	11,264	9,736	14,719	3,729	2,552	581	336	199	305	6,572	14,321	17,133	

From *springs*, with the aid of capacious storage reservoirs, it might be possible to utilize fifty per cent. of the above volume of percolation. From *wells*, it would rarely be possible to utilize more than from ten to twenty per cent. of the volume.

Fifty per cent. of the above total estimated volume of percolation would be equivalent to a continuous supply of 5 cubic feet per day each, to 3391 persons, or 126,823 gallons per diem; and ten per cent. of the same volume would be equivalent to a like supply (37.4 gals. daily) to 678 persons, or 25,357 gallons per diem.

Wells sunk in a great sandy plain bordering upon the ocean, or bordered by a dyke of impervious material, would give greater and more favorable results, for in such case the conditions of subterranean storage would be most favorable, but such are exceptional cases.

CHAPTER VIII.

IMPURITIES OF WATER.

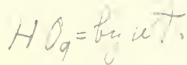

97. The Composition of Water.—If a quantity of pure water is separated, chemically, the constituent parts will be two in number, one of which weighing one-ninth as much as the whole will be hydrogen, and the other part oxygen; or if the parts of the same quantity be designated by volume, two parts will be hydrogen and one part oxygen.

These two gases, in just these proportions, had entered simultaneously into a wondrous union, the mystery of which the human mind has not yet fathomed. In fact, many years of intense intellectual labor of such profound investigators as Cavendish, Lemery, Lavoisier, Volta, Humboldt, Gay Lussac, and Dumas were consumed before the discovery of the proportions of the two gases that were capable of entering into this mystic union.

98. Solutions in Water.—If two volumes of oxygen are presented to two volumes of hydrogen, one only of the oxygen volumes will be capable of entering the union, and the other can only be diffused through the compound, water.

When alcohol is poured into water it does not become a part of the water, but is diffused through it.

This we are assured of, since by an ingenious operation we are able to syphon the alcohol out of the water by a method entirely mechanical. If we put some sugar, or alum, or carbonate of soda into water, the water will cause the crystals to separate and be diffused throughout the liquid, but they will not be a part of the water. The water

might be evaporated away, when the sugar, or alum, or soda would have returned to its crystalline state. In these cases, the surplus hydrogen, the alcohol, and the constituents of the crystalline ingredient are diffused through the water as impurities.

If in a running brook a lump of rock salt is placed, the current will flow around it, and the water attack it, and will dissolve some of its particles, and they will be diffused through the whole stream below. A like effect results when a streamlet flows across a vein of salt in the earth. In like manner, if water meets in its passage over or through the earth, magnesium, potassium, aluminium, iron, arsenic, or other of the metallic elements, it dissolves a part of them, and they are diffused through it as impurities. In like manner, if water in its passage through the air, as in showers, meets nitrogen, carbonic acid, or other gases, they are absorbed and are diffused through it as impurities.

99. Properties of Water.—Both oxygen gas and hydrogen gas, when pure, are colorless, and have neither taste nor smell. Water, a result of their combination, when pure, is transparent, tasteless, inodorous, and colorless, except when seen in considerable depth.

The solvent powers of water exceed those of any other liquid known to chemists, and it has an extensive range of affinities. This is why it is almost impossible to secure water free from impurities, and why almost every substance in nature enters into solution in water. There is a property in water capable of overcoming the cohesive force of the particles of matter in a great variety of solids and liquids, and of overcoming the repulsive force in gases. The particles are then distributed by molecular activities, and the result is termed *solution*.

Some substances resist this action of water with a large

degree of success, though not perfectly, as rock crystals, various spars and gems, and vitrified mineral substances.

100. Physiological Effects of the Impurities of Water.—When we remember that seventy-five per cent. of our whole body is constituted of the elements of water, that not less than ninety-five per cent. of our healthy blood, and not less than eighty per cent. of our food is also of water, we readily acknowledge the important part it plays in our very existence.

Water is directly and indirectly the agency that dissolves our foods and separates them, and the vehicle by which the appropriate parts are transmitted in the body, one part to the skin, one to the finger-nail, one to the eye-lash, to the bones phosphate of lime, to the flesh casein, to the blood albumen, to the muscles fibrin, etc. When the stomach is in healthy condition, nature calls for water in just the required amount through the sensation, thirst. Good water then regulates the digestive fluids, and repairs the losses from the watery part of the blood by evaporation and the actions of the secreting and exhaling organs. Through the agency of perspiration it assists in the regulation of heat in the body; it cools a feverish blood; and it allays a parching thirst more effectually than can any fermented liquor. Water is not less essential for the regulation of all the organs of motion, of sight, of hearing, and of reason, than is the invigorating atmosphere that ever surrounds us, to the maintenance of the beating of the heart.

If from a simple plant that may be torn asunder and yet revive, or a hydra that may be cut across the stomach or turned wrong side out and still retain its animal functions, the water is quite dried away; if but for an instant, man, with his wonderful constructive ability, and reason almost

divine, cannot restore that water so as to return the activity of life and the power of reproduction.

The human stomach and constitution become toughened in time so as to resist obstinately the pernicious effects of certain of the milder noxious impurities in water, but such impurities have effect inevitably, though sometimes so gradually that their real influence is not recognized until the whole constitution has suffered, or perhaps until vigor is almost destroyed.

Note the effect of a few catnip leaves thrown into drinking water, which will act through the water upon the nerves; or an excess of magnesia in the water will neutralize the free acids in the stomach, or lead in the water will act upon the gums and certain joints in the limbs, or alcohol will act upon the brain; and so various vegetable and mineral solutions act upon various parts of the body.

It would be fortunate if the pernicious impurities in water affected only matured constitutions, but they act with most deplorable effect in the helplessness of youth and even before the youth has reached the light. These impurities silently but steadily derange the digestive organs, destroy the healthy tone of the system, and bring the living tissues into a condition peculiarly predisposed to attack by malignant disease.

† **101. Mineral Impurities.**—The purest natural waters found upon the earth are usually those that have come down in natural streams from granite hills; but if a thousand of such streams are carefully analyzed, not one of them will be found to be wholly free from some admixture. This indicates that in the economy of nature it has not been ordained to be best for man to receive water in the state chemically called pure. A United States gallon of water weighs sixty thousand grains nearly. Such waters as phy-

sicians usually pronounce good potable waters have from one to eight of these grains weight, in each gallon, of certain impurities diffused through them. These impurities are usually marshalled into two general classes, the one derived more immediately from minerals, the other derived directly or indirectly from living organisms. The first are termed *mineral* impurities, and the other *organic* impurities.

The *mineral* impurities may be resolved by the chemist into their original elementary forms, and they are usually found to be one or more of the most generally distributed metallic elements, as calcium, magnesium, iron, sodium, potassium, etc. If as extracted they are found united with carbonic acid, they are in this condition termed *carbonates*; if with sulphuric acid, *sulphates*; if with silicic acid, *silicates*; if with nitric acid, *nitrates*; if with phosphoric acid, *phosphates*, etc.; if one of these elements is formed into a compound with chlorine, it is termed a *chloride*; if with bromine, it is termed a *bromide*, etc. A few metallic elements may thus be reported, in different analyses, under a great variety of conditions.

102. Organic Impurities.—There are a few elements that united form *organic* matter, as carbon, oxygen, hydrogen, nitrogen, sulphur, phosphorus, potassium, calcium, sodium, silicon, manganese, magnesium, chlorine, iron, and fluorine. Certain of these enter into each organized body, and their mode of union therein yet remains sealed in mystery. In the results we recognize all animated creations, from the lowest order of plants to the most perfect quadrupeds and the human species. All organic bodies may, however, upon the extinction of their vitality, be decomposed by heat in the presence of oxygen, and by fermentation and putrefaction.

The metallic elements are, in the impurities of good

potable waters, usually much in excess of the organic elements, but the contained nitrogenized organic impurities indicate contaminations likely to be much more harmful to the constitution, and especially if they are products of animal decompositions.

103. Tables of Analyses of Potable Waters.—We will quote here several analyses of running and quiet waters that have been used, or were proposed for public water supplies, indicating such impurities as are most ordinarily detected by chemists in water. For condensation and for convenience of comparison they are arranged in tabular form.

TABLE No. 32.

ANALYSIS OF VARIOUS LAKE, SPRING, AND WELL WATERS.

	Jamaica Pond, near Brooklyn, L. I.	Flax Pond, near Lynn, Mass.	Shuice Pond, near Lynn, Mass.	Breeds Pond, near Lynn, Mass.	Reeds' Lake, near Grand Rapids, Mich.	Lake Konomac, near New London, Conn.	Loch Katrine, near Glasgow, Scotland.	Spring Water, near Clapham, England.	Well at Highgate, England.	Artesian Well, at Hatton, England.	Artesian Well, at Colney Hatch, England.
Carbonate of Lime.....	1.092	.700	.400	.600	4.65	.096	12.58 ₃	1.768	5.420
“ Magnesia.....	.408	.692	.320	.612	1.13216	11.65 ₈734	1.101
“ Soda.....734	1.101
Protocarbonate of Iron.....	12.677	5.921
Chloride of Sodium.....	.244	.612	.408	.504	9.556	8.032	4.00
“ Magnesia.....	.328	trace	3.553
“ Calcium.....	.120144	4.930
“ Potassium.....	1.62
Alkaline Chlorides.....
Sulphate of Lime.....	.120	.300	.300	.270	1.29	.433	12.775	3.798
“ Magnesia.....	.288050381
“ Potash.....064	.070	14.217	trace	2.160
“ Potassa.....
“ Soda.....080	.086	.880	5.662
Phosphate of Lime.....	trace	8.776	7.935	8.719	4.811
Nitrate of Lime.....	trace	trace	trace
“ Magnesia.....	33.457
Oxide of Iron.....	.044	.840	trace	.096	.85	.035	trace	14.231
Ammonia.....
Silica.....156	.144	.120	.75	2.43	.170	.200	.747	.042	.559
Organic Matter.....	.008	2.208	1.344	2.184	8.75	1.80	.900	3.419
Total Solids.....	2.652	5.652	3.072	5.316	17.750	7.831	2.244	64.629	83.549	35.685	27.323
Soluble Organic Matter.....392
Hardness, Degrees by Clark's Scale.....	0.80

TABLE
ANALYSIS OF VARIOUS

	Hudson River, above Albany, N. Y.	Hudson River, above Poughkeepsie, N. Y.	Connecticut River, above Holyoke, Mass.	Connecticut River, above Springfield, Mass.	Schuylkill River, above Philadelphia, Pa.	Croton River, above Croton Dam, N. Y.	Croton River Water in New York Pipes, N. Y.	Saugus River, near Lynn, Mass.
The quantities are expressed in grains per U. S. Gallon of 231 cubic inches, or 58,372 $\frac{17.5}{1000}$ grains.								
Carbonate of Lime	1.059	.85	.90	1.56	2.67	1.52	1.812
“ Magnesia56	.67	.60	1.90	.84	...
“ Soda	2.126
Protocarbonate of Iron
Chloride of Sodium361	.108	.676	.72	.49	.402480
“ Magnesia161
“ Calcium86	.90	...
“ Potassium070	.83
“ “ and Sodium090	.75
Sulphate of Lime980146	.156	.29	.158280
“ Magnesia
“ Potash076028
“ Potassa43	.179
“ Soda	2.78548	.260040
Silicate of Potassa
“ Soda
Nitrate of Lime
Oxide of Iron	3.644	.156	.168	.09	trace	...	trace
Iron Alumina and Phosphates
Ammonia
Silica408	2.201	.132	.133	.30	.62	.46	1.104
Organic Matter699	.776	1.728	1.68067	...	2.880
Total Solids	2.685	12.699	4.408	6.007	4.24	7.719	3.720	6.624
Soluble Organic Matter
Solid residue obtained on evaporation
Free Carbonic Acid
Hardness, Degree by Clarke's Scale	3.3543	.51

* Notwithstanding the exceeding importance of an intelligent microscopic examination of each proposed domestic water supply, in addition to the chemical analysis, no record of such examination is found accompanying the reports upon the waters herein enumerated. Lenses of the highest microscopical powers should be used for such purpose, and immersion lenses are required in many instances.

To obtain specimens of sedimentary matters, the sample of water may first

No. 33.

RIVER AND BROOK WATERS.*

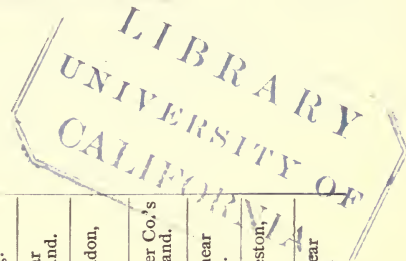

Chickopee River, near Springfield, Mass.	Mill River, near Springfield, Mass.	Grand River, above Grand Rapids, Mich.	White River, in Filter Wells on Bank, at Indianapolis, Md.	Fallkill Creek, near Poughkeepsie, N. Y.	Wappinger's Creek, near Poughkeepsie, N. Y.	Lynde Brook, near Worcester, Mass.	Thames River, above London, Eng.	Dee River, near Aberdeen, Scotland.	New River, London, Eng.	Hampstead Water Co.'s Supply, England.	Cowley Brook, near Preston, Eng.	Loud Scales, Preston, England.	Dutton Brook, near Preston, Eng.
.65	1.30	7.18	10.02	.51	6.221	.334	13.13	.709	6.521	4.128	.575	6.131	1.343
.59	.87	1.8405909	2.944	.238	.966	.217
..40	.322	4.245
..147	.242	.152
.532	.865	..	4.70	1.20	trace	..	1.56	..	1.442	5.662	.938	.550	.970
..091
..	2.37334317	..
.75	.07	1.38	1.501
.64	.11559
.13	.260	..	3.00	2.73	.101	2.693	..	.175	.321	.105
..394
..
..926	1.167	.287	.133	.159
..	trace	..	.150	1.242	12.625	..	.780	.171
..093
..348
..017	.058
..	trace	trace
..	trace	trace
.12	trace	1.37	..	trace417	.058
1.104	3.864	18.75	.50	.15	trace	.417	2.37	..	2.327	1.535
4.516	7.339	31.24	20.99	6.74	11.459	1.727	20.19	..	16.496	29.678	3.317	1.774	3.912
..	1.167	1.168	.785
..	16.327	25.527	3.502	9.340	4.144
..	6.037	5.562	..	4.633	..
.30	.63	14.5	..	14.9	9.8	1.25	12	1.50

rest a day in a deep, narrow dish, and then have its clear upper water syphoned off. The remainder of the water may then be poured into a conical glass, such as, or similar to, the graduated glasses used by apothecaries, and then again allowed to rest until the sediment is concentrated, when the greater part of the clear water may be carefully syphoned off and the sediment gathered and transferred to a slide, where it should be protected by a thin glass cover.

TABLE No. 34.
ANALYSIS OF STREAMS IN MASSACHUSETTS.*
(Quantities in Grains per U. S. Gallon.)

			SOLID RESIDUE OF FILTERED WATER.			CHLORINE.
	FREE AMMONIA.	ALBUMINOID AMMONIA.	INORGANIC.	ORGANIC AND VOLATILE.	TOTAL.	
Merrimac River—Mean of 11 examinations above Lowell.....	0.0027	0.0066	1.38	1.01	2.39	0.08
Merrimac River—Mean of 12 examinations above Lawrence.....	.0026	.0064	1.41	.98	2.39	.12
Merrimac River—Mean of 11 examinations below Lawrence.....	.0018	.0074	1.54	1.05	2.59	.11
Blackstone River, near Quinsigamund Iron Works105	.015	1.98	1.98	3.96	.50
Blackstone River, just above Millbury.....	.024	.012	2.62	1.75	4.37	.37
Blackstone River, below Blackstone004	.008	1.66	1.21	2.87	.21
Charles River, at Waltham.0035	.0096	2.26	1.07	3.33	.23
Sudbury River, above Ashland....	.0030	.0107	1.63	2.50	4.13	.23
Sudbury River, at Concord.....	.0026	.0115	2.22	1.31	3.53	.18
Concord River, at Concord.....	.0047	.0158	1.80	1.42	3.22	.20
Concord River, at Lowell.....	.0027	.0097	2.85	1.59	4.44	.26
Neponset River, at Readville0027	.0158	1.40	1.98	3.38	.29
Neponset River, below Hyde Park.	.0064	.0175	2.10	1.77	3.87	.30

104. Ratios of Standard Gallons.—A portion of the above analyses were found with their quantities of impurities expressed in grains per imperial gallon, a British standard measure containing 70,000 grains, and some of them expressed in parts per 100,000 parts. They have all been, as have those following, reduced to grains in a U. S. standard gallon, containing 58372.175 grains.

The degrees of hardness are expressed by Clark's scale, which refers to the imperial gallon.

* Selected from the Fifth Annual Report of the Mass. State Board of Health.

The other quantities may be easily reduced to equivalents for imperial gallons, by aid of logarithms of the quantities or of the ratios :

Imperial gallon—No. of grains.....	70000	Logarithm, 4.845098
U. S. gallon—No. of grains.....	58372.175	“ 4.766206
Ratio of imp. to U. S. gallon.....	1.199201	“ 0.078892
“ of U. S. to imperial gallon.....	.833886	“ $\bar{1}.921108$
“ of cubic foot to one imp. gallon...	6.23210	“ 0.794634
“ “ “ “ “ “ U. S. “ . . .	7.48052	“ 0.873932
“ “ one imp. gall. to one cu. ft....	.16046	“ $\bar{1}.205367$
“ “ “ U. S. “ “ “ “ “....	.13368	“ $\bar{1}.126066$

The following analyses of various well waters are in a more condensed form :

TABLE NO. 33.

ANALYSES OF WATER SUPPLIES FROM DOMESTIC WELLS.

(Quantities in Grains per U. S. Gallons.)

WELLS.	MINERAL MATTERS.	ORGANIC MATTERS.	TOTAL SOLIDS.	HARDNESS, CLARK'S SCALE.
Albany, Capital Park	65.20
“ Lydius Street.....	19.24
“ average of several.....	48.69
Boston, Beacon Hill	50.00
“ Tremont Street.....	26.60
“ Long Acre.....	56.80
“ average of three.....	44.46
“ Old Artesian.....	54.35	1.85	55.20
Brookline, Mass.....	9.89	4.08	13.97
Brooklyn, L. I.....	45.40
“ average of several.....	48.83
Charlestown, Mass.....	26.40
Cape Cod.....	10.01	2.41	12.42
Detroit, Mich.....	116.46
Dayton, Ohio.....	56.50
Dedham, Mass., Driven Pipe.....	5.12	1.12	6.24
“ “ Artesian.....	4.08	1.11	5.19
Fall River, Mass., average of seventeen..	25.16	7.00	32.16	12.17
Hartford, Conn., No. 1.....	19.33	8.39
“ “ No. 2.....	32.16	13.44
“ “ No. 3.....	37.10
“ “ No. 4.....	43.60	10.55
“ “ No. 5.....	69.05	19.22

ANALYSES OF WATER SUPPLIES FROM DOMESTIC WELLS—(Continued).

WELLS.	MINERAL MATTERS.	ORGANIC MATTERS.	TOTAL SOLIDS.	HARDNESS, CLARK'S SCALE.
Indianapolis, Ind.....	60.00
Lowell, Mass., average of fifteen.....	39.33	8.71
London, Eng., Leadenhall Street.....	90.38	9.59	99.97
“ “ St. Paul's Churchyard.....	62.54
Lambeth, “	83.39
Lynn, Mass.....	34.08
Manhattan, N. Y.....	104.00
“ “ average of several.....	49.00
New Haven, Conn., average of five.....	20.32
New York, west of Central Park.....	38.95	4.59	43.54
“ average of several.....	58.00
Newark, N. J., average of several.....	19.36
Providence R. I., average of twenty-four.....	24.05	8.82	33.02	10.87
“ “ purest of “.....	7.76	3.35	11.11	7.70
“ “ foulest of “.....	56.99	24.12	81.11	22.26
Portland, Me., average of four.....	13.35	5.13	18.48
Pawtucket, R. I.....	29.16	3.03	32.19
“ “	25.08	3.73	28.81
“ “	18.68	3.62	22.30
Paris, France, Artesian.....	9.86
Rochester, N. Y., average of several.....	30.00
Rye Beach, N. H.....	6.08	2.43	8.51
Springfield, Mass.....	7.82	2.03	9.85
“ “	8.81	2.01	10.82
“ “	11.53	1.91	13.44
“ “	14.83	3.08	17.91
Schenectady, N. Y., State Street.....	46.88	2.33	49.21
Taunton, Mass.....	20.14	2.98	23.12
“ “	39.86	4.09	43.95
Waltham, “	7.68	4.08	11.76
“ “ Pump.....	17.79	7.46	25.25
Winchester, “	4.00	2.40	6.40
“ “	8.00	2.40	10.40
“ “	10.80	2.04	13.20
Woburn, Mass., average of four.....	51.52	4.60	56.12

105. Atmospheric Impurities.—The constant disintegration of mineral matters and the constant dissolutions of organic matters, and their disseminations in the atmosphere, offer to falling rains ever-present sources of admixture, finely comminuted till just on the verge of transformation into their original elements. The force of the winds, the movements of animals, the actions of machines,

are every moment producing friction and rubbing off minute particles of rocks and woods and textile fabrics. Decaying organisms, breaking into fibre, are caught up and wafted and distributed hither and thither.

The atmosphere is thus burdened with a mass of lifeless particles pulverized to transparency.

A ray of strong light thrown through the atmosphere in the night, or in a dark room, reveals by reflection this sea of matter that vision passes through in the light of noon-day. These matters the mists and the showers absorb, and dissolve in solution.

The respirations of all animate beings, the combustions of all hearth-stones and furnaces, and the decaying dead animals and vegetables, continually evolve acid and sulphurous gases into the atmosphere. Chief among the deleterious gases arising from decompositions are carbonic acid, nitrous and nitric acids, chlorine, and ammonia. These are all soluble in water, and the mists and showers absorb them freely. Ehrenberg states that, exclusive of inorganic substances, he has detected three hundred and twenty species of organic forms in the dust of the winds. Hence the so-called pure waters of heaven are fouled, before they reach the earth, with the solids and gases of earth.

106. Sub-surface Impurities.—The waters that flow over or through the crevices of the granites, gneisses, serpentines, trappeans, and mica slates, or the silicious sandstones, or over the earths resulting from their disintegrations, are not usually impregnated with them to a harmful extent, they being nearly insoluble in pure water.

The limestones and chalks often impart qualities objectionable in potable waters, and troublesome in the household uses and in processes of art and manufacture.

The drift formation, wherever it extends, if unpolluted

by organic remains upon or in its surface soil, usually supplies a wholesome water.

The presence of carbonic acid in water adds materially to its solvent power upon many ingredients of the soil that are often present in the drift, such as sulphate of lime, chloride of sodium, and magnesian salts, and upon organic matters of the surface.

Carbonic acid in rain-water that soaks through foul surface soils, gives the water power to carry down to the wells a superabundance of impurities.

The presence of ammonia is a quite sure indication of recent contamination with decaying organic matter capable of yielding ammonia, whether in spring, stream, or well. This readily oxidizes, and is thus converted into nitrous acid and by longer exposure into nitric acid.

These acids combine freely with a lime base, as nitrate and nitrite of lime.

Analysts attach great importance to the nature of the nitrates and nitrites present, as indications of the *nature* of the contaminations of the water.

Some of the subterranean waters penetrate occasional strata that wholly unfit them for domestic use. A portion of the carboniferous rocks are composed so largely of mineral salts that their waters partake of the nature of brine, as in parts of Ohio; in the Kanawha Valley, West Virginia; and in parts of New York State; for instance, at Syracuse, where the manufacture of salt from sub-surface water has assumed great commercial importance. In other sections, the bituminous limestones are saturated with coal-oils, as in the famous oil regions of Pennsylvania. The dark waters from the sulphurous strata of the Niagara group of the Ontario geological division are frequently impregnated with sulphuretted hydrogen.

All along the western flank of the Appalachian chain, from St. Albans and Saratoga on the north to the White Sulphur Springs on the south, the frequent mineral springs give evidence of the saline sub-structure of the lands, while like evidences have recently become conspicuous in certain portions of Kentucky, Arizona, New Mexico, Utah, California, and Oregon.

107. Deep-well Impurities.—Deep well and spring waters, except those from dipping sand or sandstone strata, are especially liable to impregnations of mineral salts.

These impurities from deep and hidden sources, when present in quantities that will be harmful to the animal constitution, are almost invariably perceptible to the taste, and are rejected instinctively.

108. Hardening Impurities.—The solutions of salts of lime and magnesia are among the chief causes of the quality called *hardness* in water. Their carbonates are broken up by boiling, for the heat dissipates the carbonic acid, when the insoluble bases are deposited, and, with such other insoluble matters as are present, form incrustations such as are seen in tea-kettles and boilers where hard waters have been heated. The carbonates, in moderate quantities, are less troublesome to human constitutions than to steam users. The effects of the carbonates are termed *temporary hardness*. The sulphates, chlorides, and nitrates of lime and magnesia are not dissipated by ordinary boiling. Their effects are therefore termed *permanent hardness*.

An imperial gallon of pure water can take up but about two grains of carbonate of lime, when it is said to have two degrees of hardness; but the presence of carbonic acid in the water will enable the same 70,000 grains of water to dissolve twelve, sixteen, or even twenty grains of the carbonate, when it will have twelve, sixteen, or twenty degrees of

hardness, according to the number of grains taken into solution.

These salts of lime and magnesia, and of iron, in water, have the property of decomposing an equivalent quantity of soap, rendering it useless as a detergent; thus, one degree or grain of the carbonate neutralizes ten grains of soap; two degrees, twenty grains of soap; three degrees, thirty grains, etc.

This source of *waste* from foul hard waters, which extends to the destruction of many valuable food properties, as well as to destroying soap, is not sufficiently appreciated by the general public.

It may be safely asserted that a foul hard well water will destroy from the family that uses it, more value each year than would be the cost in money of an abundant supply of water for domestic purposes, from an accessible public water supply; and this refers to purchased articles merely, and not to destruction of human health and energy, which are beyond price.

109. Temperatures of Deep Sub-surface Waters.

—Very deep well and spring waters have, upon their first issue, too high a temperature for drinking purposes, as from the artesian wells of the Paris basin, which rise at a temperature of 82° Fah., and as from hot springs, among which, for illustration, may be mentioned the Sulphur Springs, Florida, of 70° Fah., the Lebanon Springs, N. Y., of 73° F.; and, as extremes of high temperature, the famous geysers of the Yellowstone Valley, at a boiling temperature, and the large hot spring near the eastern base of the Sierra Nevadas and Pyramid Lake, whose broad pool has a temperature of 206°, and central issue 212°. The springs at Chaudes Aigues, in France, have a temperature of 176°, and the renowned geysers of Iceland, of 212°.

Artesian wells have temperatures for given depths approximately as follows :

TABLE No. 36.

ARTESIAN WELL TEMPERATURES.

Depth in Feet.....	100	500	1000	1500	2000	2500	3000
Temperature, deg. Fah.....	52	59	68	76	85	94	102

about 8° for each 500 feet.

110. Decomposing Organic Impurities.—If we resolve, chemically, a piece of stone, ore, wood, fruit, a cup of water, or an amputated animal limb, into their simple elements within the limits of exact chemical investigation, we shall find that their varied compositions and properties are results of combinations, substantially, of the same few elements ; and that the *organic* substances—that is, such as are the result of growth under the influence of their own vitality—are composed chiefly of carbon, oxygen, hydrogen, and nitrogen, with spare proportions of a few metalloids, as above enumerated. The general order of predominance of the gases and metalloids is not, however, quite the same in mineral as in organic matters. But notwithstanding this apparent similarity of chemical compositions, there is a quality in organic substances accompanying the vital force, that makes it as widely different in essential characteristics from simple mineral compounds as life is from death.

The mysterious properties which accompany only the vital force do not submit to analyses by human art. They are known only by their results and their effects.

In the natural decomposition of animal matters, especially in their stage of putrefaction, their elements are often in a condition of molecular activity that will not admit of their being safely brought into contact with the human

circulation, where they will be liable to induce similar conditions.

Witness the extreme danger to a surgeon who receives a minute quantity of animal fluid into a sore upon his hand, when dissecting a dead body, even though the life has been extinct but one or two days.

The excreta of living animals also passes through a decomposing transformation, in which stage they cannot safely be brought into contact with the human circulation, however finely they may be dissolved in water, when received.

The process of decay in dead animal bodies, and of decomposition of vegetable substances, is quite rapid when moisture and an abundance of atmospheric air, or available oxygen in any form, are present, and a warm temperature promotes the activity of the elements; hence the same matter does not long remain in its most objectionable state, but from the multiplicity of bodies on every hand, a constant source of pollution may be maintained.

Potable waters, when exposed to those organic matters in process of rapid decay, meet perhaps their most fatal sources of natural contamination, *that are not readily detected by the eye and tongue.*

111. Vegetable Organic Impurities.—Nature around us swarms with an abundance of both vegetable and animal life, in air, in earth, in stream and sea, and therefore death is constantly on every hand, and its dissolutions meet the waters wherever they fall or flow. There are numerous plants, trees, insects, and animals that we recognize day by day, but there are undoubtedly species and classes more innumerable above and below, that we can discover only when our vision is aided by magnifying lenses.

Upon the meadow pools and small ponds of the swamps,

species of microscopic fungi, not unlike the mould upon decaying fruit, though less luxuriant, are found in abundance by searchers who suspect their presence. To the general observer they appear as dust upon the water or give to it a slight appearance of opaqueness.

There are species of fresh-water algæ that thrive in abundance, peculiar to all seasons, and they are said to have been found in the heated waters of boiling spring basins, and also in healthy life within an icicle, and they are the last of life high up on the mountain slopes, near the borders of eternal snows. Ditches, pools, springs, rivers, lakes, and dripping grottoes have each their native class. In stagnant waters abound the oscillatoriæ of dull-greenish or dark-purplish or bluish color, forming dense slimy strata, and the brighter green zygenemas which float or lie entangled among the water plants.

The desmids abound in the early spring of the year, and various algæ flourish in the autumn. A thrifty fungus of the genus *Noctos* frequents the quiet waters of lower New England and the Middle States.

These plants at their dissolution often impart an oily appearance, a greenish or brownish color, and a somewhat offensive smell to the water. The *noctos*, while in active growth, forms part of the green scum often seen upon the surface of still water. The fishy smell and the color which they impart to the water in decomposing seems to be largely due to an essential oil which they give out when breaking up.

112. Vegetal Organisms in Water-Pipes. — A species of *confervæ* has been found growing and multiplying rapidly within water-pipes, having taken root in the fine organic sediment deposited from feeble currents of water in the dead ends or in the large mains. These microscopic plants, after maturing in abundance, are detached

by the current, decompose, and impart an appreciable amount of odor and taste to the water, reduce its transparency and give a slight tinge of color.

113. Animate Organic Impurities.—The waters are not less pregnant with animate than vegetal life. The microscope has here extended our knowledge of varieties and numbers of species also, especially in waters infused with organic substances.

The tiny infusoria were first discovered in strong vegetable infusions, hence the name given to them; but with the extension of microscopical science, the class has been extended to include a variety of animate existences, from the quiet fresh water sponge to the most energetic little creatures that battle ferociously in a drop of water.

Dr. Crace Calvert has shown* that when albumen from a new laid egg is introduced in pure distilled water and exposed to the atmosphere, minute globular bodies soon appear having independent motion. These he denominated monads.

Their appearance was earlier in lake water than in distilled water, and earliest and most abundant in solutions of largest exposure to the atmosphere.

These monads have diameters of about $\frac{1}{128000}$ of an inch; in their next successive stage, of about $\frac{1}{20000}$ of an inch; and then of about $\frac{1}{6400}$ of an inch. He denominates them vibrios in the two last stages. Then they change into cells, having power to pass over the field of the microscope rapidly.

The albuminous products of decaying leaves and plants in water also promote the generation of aquatic life, and dead animal substances are almost immediately inhabited by a myriad of creatures.

* Papers read before the Royal Society, London.

The discussion upon the question of spontaneous generation in progress at the opening of our centennial year, is adding many new and interesting experimental results to the researches of Pasteur and Schroeder, relating to the propagation of bacterial life from atmospheric mote germs, and the agency of germs in the spread of epidemic *cōntagia*. Prof. Tyndall and Dr. Bastian, the leading controversialists in this discussion, are agreed that both vegetable and animal infusions, if exposed to the summer atmosphere, will, ordinarily, abound in bacterial life in about three days.

There are also in the streams and lakes the larger zoophytes, mollusca, articulata, and crustacea, some of which are familiar products of the waters, and also fish in great variety.

But all of these do not pass through the objectionable putrefactive stage described above. The weaker classes are food for the stronger, and the smaller of some classes food for the larger of the same class. Of the many that come into being, comparatively few survive till a natural death terminates their existence, but each devours others for a substantial part of its own nourishment, and hides, fights, or retreats to preserve its own existence.

114. Propagation of Aquatic Organisms.—A warm temperature of both air and water are requisite for the abundant propagation of aquatic life. The presence of a considerable amount of either vegetable or animal impurities in the waters seems also a requisite for the lower grades of life.

How far certain electrical influences in the air and water control the results are not yet determined. Certain it is, however, that the microscopic creatures sometimes swarm suddenly in abundance in quiet lakes and pools, in a seemingly unaccountable manner, remain in abundance for a few days, or possibly a few weeks in rare seasons, and then

as mysteriously disappear. There is a similar appearance of microscopic plants, when all the natural conditions favorable thereto occur simultaneously, but their coming cannot always be predicted, neither can the time of their disappearance be foretold.

A very brief existence is allotted to a large share of the minute vegetal and animate aquatic beings we have had in consideration. Perhaps the greater share of the animate, count scarce a single circuit of the sun in their whole term; others soon pass to a higher stage in their existence, and are thereafter terrestrial in their habits.

115. Purifying Office of Aquatic Life.—One of the chief offices of the inferior inhabitants of the waters is to aid in their purification by devouring and assimilating the dead and decaying organic matters.

The infusorial animalculæ are undoubtedly encouraged in their propagation by the presence of impurities so far as to be an unmistakable indication of such impurities; and they, on the other hand, attack and destroy such impurities for their own nourishment, when they are devoured, and their devourers devoured by higher existences, till the last become food for fish that constitutes a food for man.

This, and this only, is the proper channel through which the decomposing organic impurities in water should reach the human stomach, having by Nature's wonderful processes of assimilation been first converted into superior living tissues.

A great variety of fish are daily consumed for our food, also of mollusca from salt water, as clams, oysters, and mussels, also of crustacea, as lobsters, crabs, shrimp, etc.; hence we infer that the higher orders of fresh water inhabitants are not harmful while living therein, and are nourishing as food, if consumed while the influence of their vital force remains.

The action of oxygen upon organic bodies tends always powerfully to decomposition, but is counteracted by the vital force. When the vital force ceases then decomposition soon begins, and then the body acted upon is unfitted for the human digestive organs.

116. Intimate Relation between Grade of Organisms and Quality of Water.—The grade and character of the growths in fresh water are almost invariably reliable tests of the quality of the water, and if the plants be fine-grained, firm, and delicate in outline, or the fish trim in form, lithe in motion, and fine in flavor, the water is most sure to be good.

117. Animate Organisms in Water-Pipes.—Nearly all of the animate aquatic existences must rise frequently to the water surface to secure their necessary share of atmospheric oxygen. If any of them, not having tracheal gills, or their equivalents, to enable them to breathe a long time under water, are drawn into the pipes, and are thus cut off from their supply of oxygen, they soon perish. Then, if the water is not of low temperature, their decomposition soon commences, and an offensive gas from their bodies enters into solution with the water.

118. Abrasion Impurities in Water.—The most prominent sources of the frictional impurities are the banks of clay and sand bordering upon the running streams, and the plowed fields of the hillside farms. The movement of these sedimentary matters in suspension is dependent largely upon the force of storms and floods, and in the majority of streams their movement is rapid toward the sea, where they are massed in foundations of lagoons and islands.

With them are swept away a great bulk of the matured products of vegetation that annually ripen in the forest, the field, and upon the banks of the streams.

119. Agricultural Impurities.—It remains now to review in outline the *artificial* impurities, which are always to be shunned if known to be present, and are to be suspiciously watched for, as secret poisons lurking in the clear and sparkling water.

These are, it is true, compounds of mineral and organic matters, similar in many respects to those already considered.

Nature provides prompt acting remedies for such noxious impurities as she presents to the waters, and the seasons of most rapid fouling have the most abundant purifying resources. But when great bulks of decomposing organic matters are massed and are permitted to foul the streams with a blackening flow of disease-inducing dregs, such as are washed from fertile gardens, or pour from manufactories and sewers, no adequate, prompt, natural remedy is at hand.

One of the first results of the massing of people together is an increase in degree of fertilization of the land of their neighborhood, and thus the lands over and through which their waters flow are mixed with concentrated decomposing vegetable and animal products.

120. Manufacturing Impurities.—Manufactories, especially such as deal with organic products, are prolific sources of contamination. Among their operations and refuse may be enumerated as prominent polluters, washings of wool and vegetable dyes of woollen mills, washing of old rags and foul linens of paper-mills, the hair, scrapings, bark, and liquors of tanneries, the refuse and liquors of glue factories, bone-boiling and soap-works, pork rendering and packing establishments, slaughter-houses and gas-works.

121. Sewage Impurities.—Most foul and fearful of all

the artificial pollutions which ignorant and careless humanity permits to reach the streams are the drainage of cesspools, sewers, pig-styes, and stable-yards.

The man who permits his family to use waters impregnated with fecal substances that the bodies of other persons or animals have already excreted, and the authorities who permit their citizens to use such waters, opens for them freely the gates to aches and pains, weaknesses of body and mind, injuries of tissues and blood, attacks of chronic diseases and epidemics, and surely permits destruction of their vigor, shortens their average life, and also degenerates the entire existence of the generation they are rearing to succeed them, whom it is their duty as well as pleasure to cherish and protect.

There is no community, there are very few families, and comparatively few animals without disease. In large communities there is rarely a time when some virulent disease does not exist.

The products of the humors and fevers of each individual in large part escapes from the body in the feces and urine. If drinking water is allowed to absorb these festering matters, either in the ground or in the stream, it transmits them directly to the blood and tissues of other individuals, and a hundred deaths may result from the evacuations of a single diseased person.

122. Impure Ice in Drinking Water.—Ice is now so generally used in drinking-water in summer, to cool it immediately before drinking, that the people should be warned against such use of ice gathered from water that would have been unfit for drinking before freezing. Chemistry has fully demonstrated that ice is not entirely purified by the process of crystallization, as has been popularly believed.

The impurities that are in that portion of water that freezes, some of which have just been brought from the bottom by the vertical circulation that occurs when water is chilled at the surface, are caught among the crystals and preserved there, as even fresh meats, and fruits might be preserved. The process of purification of the water that would have gone on by the oxidation of the impurities, is checked when they are surrounded by the ice crystals, and proceeds again when the ice melts.

An instance, of much notoriety, of the effects of impure ice, was that of the sickness among the numerous guests, during the season of 1875, at one of the Rye Beach hotels, a popular resort on the New Hampshire coast.

The sickness here, confined to one hotel in the early part of the season, was, after much search by an expert physician, traced unmistakably to the ice, which was gathered from a small stagnant pond, and all the peculiar unpleasant symptoms ceased when the source was located and a purer supply of ice obtained.

An analysis of the impure ice in question, by Professor W. R. Nichols, gave the following result, by the side of which is placed a like analysis of water from Cochituate Lake, for the purpose of comparison :

	ICE FROM STAGNANT POND.		WATER FROM COCHITUATE LAKE.
	GRAINS PER U. S. GAL.		GRAINS PER U. S. GAL.
	<i>Unfiltered.</i>	<i>Filtered.</i>	
Ammonia.....	0.0121	0.0124	0.0020
Albuminoid Ammonia.....	0.0410	.0096	0.0068
Inorganic Matter.....	4.55	4.01	1.61
Organic and Volatile Matter.....	3.33	1.66	1.22
Total solid residue at 212° Fahrenheit..	7.88	5.67	2.83
Chlorine.....		1.88	.18
Oxygen required to oxidize organic matter.		0.495	

123. A Scientific Definition of Polluted Water.—

Subject, as the sensitive water is, to innumerable deteriorating and purifying influences, in its transformations and varied course from the atmosphere to the household fountain, it becomes of the greatest sanitary importance to know when the deteriorating influences still predominate, and when further purification is essential for the well being of the consumers.

Professor Frankland, an eminent English authority on the quality of drinking water, has clearly defined a minimum limit, when, in his opinion, water contains sufficient mechanical or chemical impurities, in suspension or solution, to entitle it to be considered bad, or a polluted liquid, viz. :

(a.) Every liquid which has not been submitted to precipitation produced by a perfect repose in reservoirs of sufficient dimensions during a period of at least six hours ; or which, having been submitted to precipitation, contains in suspension more than one part by weight of dry organic matter in 100,000 parts of liquid ; or which, not having been submitted to precipitation, contains in suspension more than 3 parts by weight of dry mineral matter, or 1 part by weight of dry organic matter, in 100,000 parts of liquid.

(b.) Every liquid containing in solution more than 2 parts by weight of organic carbon or 3 parts of organic nitrogen in 100,000 parts of liquid.

(c.) Every liquid which, when placed in a white porcelain vessel to the depth of one inch, exhibits under daylight a distinct color.

(d.) Every liquid which contains in solution, in every 100,000 parts by weight, more than 2 parts of any metal, except calcium, magnesium, potassium, and sodium.

(e.) Every liquid which in every 100,000 parts by weight

contains in solution, suspension, chemical combination, or otherwise, more than 0.5 of metallic arsenic.

(*f.*) Every liquid which, after the addition of sulphuric acid, contains in every 100,000 parts by weight more than 1 part of free chlorine.

(*g.*) Every liquid which, in every 100,000 parts by weight, contains more than 1 part of sulphur, in the state of sulphuretted hydrogen or of a soluble sulphuret.

(*h.*) Every liquid having an acidity superior to that produced by adding 2 parts by weight of hydrochloric acid to 1,000 parts of distilled water.

(*i.*) Every liquid having an alkalinity greater than that produced by adding 1 part by weight of caustic soda to 1,000 parts of distilled water.

(*j.*) Every liquid exhibiting on its surface a film of petroleum or hydrocarbon, or containing in suspension in 100,000 parts, more than 0.5 of such oils.

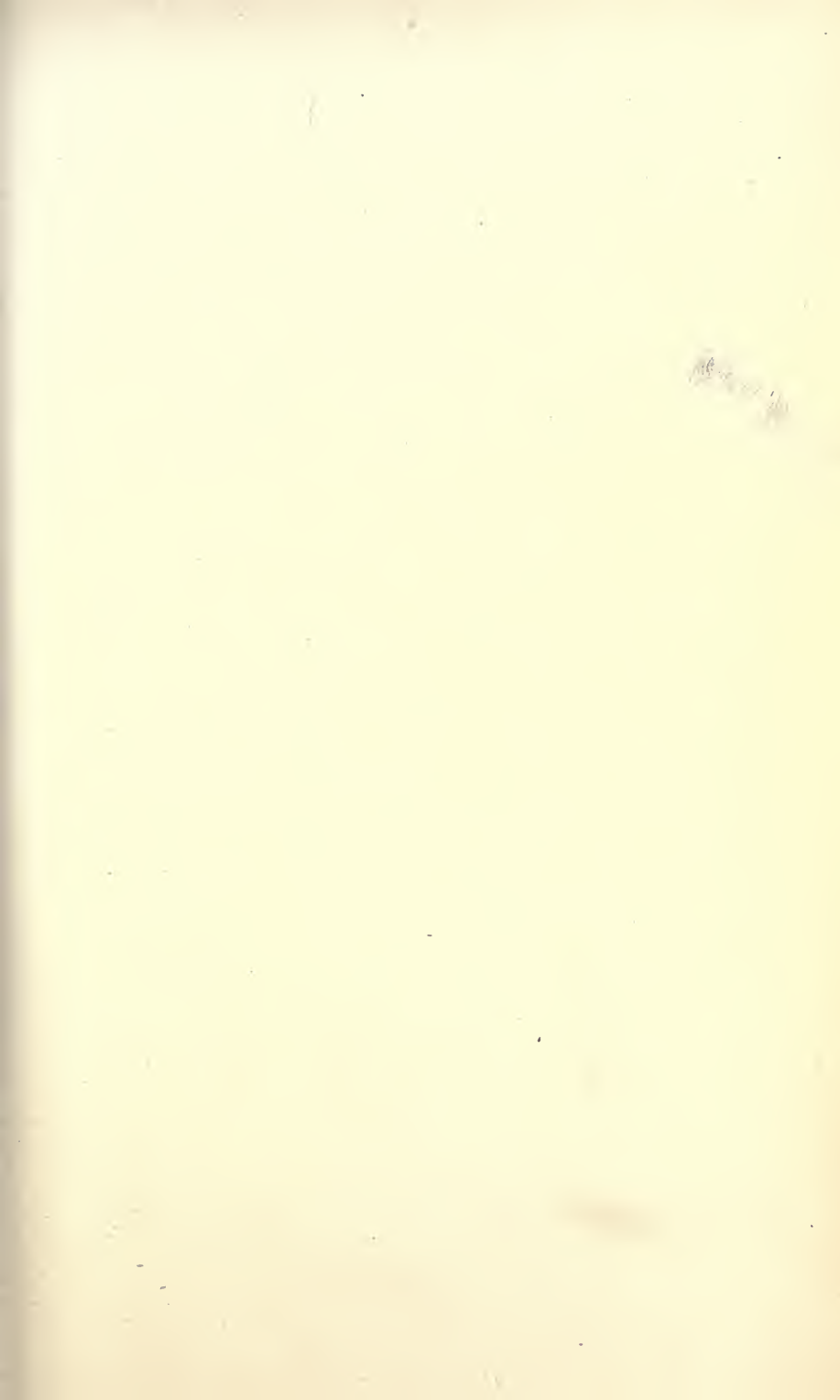



PUMPING STATION, NEW BEDFORD.

CHAPTER IX.

WELL, SPRING, LAKE, AND RIVER SUPPLIES.

It remains now to add to these general theories respecting the purity of water some special suggestions relating to the selection of a potable water.

WELL WATER.

124. Location for Wells.—We have seen that the source of water supply to wells is, immediately, the rain, and that in the vicinity of dense populations the rain reaches the surface of the earth, already polluted by the impurities of the town atmosphere.

In the open country, the water reaches the ground in a tolerably pure condition, and by judicious selection of a site for a well, its water may usually be procured of excellent quality. Country wells must, however, be entirely separated from the drainage of the stable yards, muck heaps, and house sewerage, and from soakage through highly fertilized gardens.

In towns, surface soils are continually recipients of household refuse, manures, and sewer liquors, and of dead and decaying animal matters.

These have, by abundant examples, been proved to be the most dangerous of the ordinary contaminations of shallow wells.

The strictly mineral impurities, to which all wells are to some extent subject, are not usually injurious to human constitutions, though in districts where lime is present in

the soil in considerable quantity, the resulting hardness is inconvenient and indirectly expensive.

An intelligent examination of the positions, dip, and porosity of the earth's superstrata in the vicinity of a proposed well will be a more infallible guide to its location where it will yield an unfailing, abundant, and wholesome supply, than will reliance upon "hazel forks" and "divining rods," in which the superstitious have evinced faith and by which they have often been deceived.

125. Fouling of Old Wells.—The table of analyses of well-waters above presented (page 121, et seq.) indicates that the old wells of towns are among the most impure sources of domestic water supply.

The continued increase in the hardness of well-water as the population about them becomes more dense, indicates that this increase is due to the salts of the dissolved organic refuse with which the ground in time becomes saturated.

Mr. F. Sutton, an English analyst, states, that "out of four hundred and twenty-nine samples of water sent him from wells in country towns, he was obliged to reject three hundred and seven as unfit for drinking." Another English chemist states that "much of the well-water he is called upon to examine proves to be more fit for fertilizing purposes than for human consumption."

Prof. Chandler, President of the New York City Board of Health, and Professor of Chemistry in the School of Mines, Columbia College, remarked: "In many cases, from the proximity of cesspools and privy vaults, the well-water becomes contaminated with filtered sewage, matters which, while they hardly affect the taste or smell of the water, have nevertheless the power to create the most deadly disturbances in the persons who use the waters."

Hall's "Journal of Health" remarked that, "in the

autumn many wells, which supply families with drinking and cooking water, get very low and their bottoms are covered with a fine mud, largely the result of organic decompositions, also containing poisonous matters of a very concentrated character. The very emanations from this well mud are capable of causing malignant fevers in a few hours; hence many families dependent on well-waters are made sick during the fall of the year by drinking these impregnated poisons, and introducing them directly into the circulation. Many obscure ailments and 'dumb agues' are caused in this way."

SPRING WATERS.

126. Harmless Impregnations.—The impurities of spring water are chiefly mineral in character, derived from the constituents of the earths through which their waters percolate. Among the most soluble of the earths are magnesium, calcium, potassium, and sodium, and these appear in spring waters as carbonates, bicarbonates, chlorides, sulphates, silicates, phosphates, and nitrates, and are usually accompanied by an oxide of iron and a minute quantity of silica.

The above earths are harmless, and are, in fact, considered beneficial in drinking waters, when present in moderate quantities, or not exceeding eight or ten grains per gallon. Most persons are familiar with the medicinal properties of the carbonate of magnesia, a mild cathartic, and of its sulphate (Epsom salts), a mild purgative, and with the carbonate and nitrate of potassa (pearlash and saltpetre) in the arts, and with the medicinal properties of the bromide of potassium, a mild diuretic.

Sodium is more familiarly known as common sea-salt, and calcium as common lime, of which it is the base, and

silica as the base of quartz or common sand. Spring waters are, by their passage through the earth, thoroughly filtered and relieved of suspended impurities, and therefore appear as the most clear and sparkling of all natural waters.

In the selection of a spring water, it is to be specially observed that it is free from impregnation by decaying organic matters.

127. Mineral Springs.—In illustration of the facts that clearness to the eye is not evidence of purity, or mineral impregnation of the most usual character immediately dangerous to the constitution, we append a few analyses of well-known mineral spring waters, with quantities of ingredients expressed in grains per U. S. gallon. (See page 143.)

This formidable array of chemical ingredients indicates that the waters have taken into solution the familiar minerals, magnesia, common salt, lime, iron, potash, sulphur, quartz, and clay, and the gases, oxygen, hydrogen, nitrogen, and carbonic acid.

It is much to be regretted that supplies from good springs are usually so limited in quantity.

The water supply of Dubuque, Iowa, is obtained from an adit pierced into the bluff near the city. The operations of miners working in the bluff were seriously impeded by water, and they relieved themselves by tunneling in from the face of the bluff, and thus underdraining the mine. In so doing, they intercepted numerous percolating streams of water. This water is now utilized for the supply of the city.

LAKE WATERS.

128. Favorite Supplies.—Fresh water lakes and deep ponds, whose watersheds have extents equal to at least ten times their water surfaces, are ordinarily, of all ample

TABLE NO. 37.—ANALYSES OF MINERAL SPRING WATERS.

INGREDIENTS.	Congress Springs, N. Y.	Sharon Springs, N. Y.	Sharon Springs, N. Y.	Sharon Springs, N. Y.	Avon Springs, Livingston Co., N. Y.	Rockbridge Alum Springs, Va.	Red Sulphur Springs, Monroe Co., Va.	Blue Sulphur Springs, West Va.	Greenville Springs, Harrodsburg, Ky.	Chalybeate Springs, Harrodsburg, Ky.	Blue Licks Springs, Ky.	Warm Springs, Buncombe Co., N. C.	Beer Springs, Oregon.	Bedford Springs, Bedford Co., Pa.	White Sulphur Springs, W. Va.
Carbonate of magnesia.....	32.00	4.82	1.1113	12.88
“ soda.....	16.00	5.25	5.05	6.88	34.48	22.47	15.44	8.00	3.53
“ lime.....	144.00	26.96	4.00	4.00	5.00
“ iron.....	22.96	3.44
Bicarbonate of magnesia.....
“ soda.....	30.50
“ magnesium.....	1.50
Chloride of sodium.....	1.20	1.5094	30.77	4.4816
“ calcium.....	1.12	1.50	5.68	1.01	4.31	9.92	488.25	8.9652
“ magnesium.....	434.4001	5.3202
Sulphate of soda.....	21.20	22.70	8.08	1.66	6.38	120.28	223.36	8.00	48.40	8.00	19.04
“ lime.....	38.72	4.14	20.84	9.24
“ potash.....	76.00	3.52	3.26	.55	46.55	88.48	161.92	32.30	19.32	8.48	15.00	73.13
“ magnesium.....	1.76	8.87
Bromide of magnesium.....05
Iodide of magnesium.....04
Muriate of soda.....
“ lime.....
Hydrobromate of potassa.....
Hydrosulphuret of sodium.....	10.00
“ calcium.....	3.00
Hydrosulphate of magnesia.....
“ lime.....25
Carbonic acid.....25
Sulphuric acid.....
Silicic acid.....
Hydrosulphuric acid.....
Alumina.....
Peroxide of iron.....
Protoxide of iron.....
Sulphur compound.....17
Sulphuretted hydrogen.....
Nitrogenized organic matter.....
	626.40	132.70	86.48	82.96	86.04	26.33	92.29	247.60	437.12	599.68	32.64	103.96	121.00	118.71

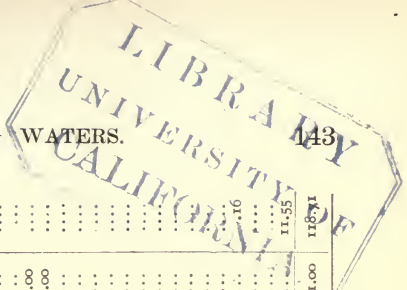

sources, least liable to objectionable impregnation in harmful quantity. When such waters have been imprisoned in their flow, by the uplifting of the rock foundations of the hills across some resulting valley, or by more recent crowding by ice-fields of masses of rock and earth débris into a moraine dam, they are bright and lovely features in their landscapes, and favorite sources of water-supplies.

The accomplishments of scientific attainments are not requisite to enable the intelligent populations to discover in these waters wholesomeness for human draughts and adaptability to quench thirsts.

When such waters are deep, and have a broad expanse and bold shores, nature is ever at work with rain and wind and sunshine, maintaining their natural purity and sparkle.

129. Chief Requisites.—The prime requisites in lakes, when to be used for domestic supplies, are *abundant inflow* and *outflow*, that will induce a general circulation; *abundant depth*, that will maintain the water cool through the heats of summer and hinder organic growth; and *a broad surface*, which the wind can press upon, and roll, and thus stir the water to its greatest depths.

These are features opposed to quietude, shallowness, and warmth, which we have seen (§ 114) to be promoters of excesses of vegetal and animal life, accompanied by a very objectionable mass of vegetable decay and animal decomposition. Fortunately, the shallow waters are oftenest at the upper ends, opposite to the usual points of draught from the lake, or in indented bays along the sides, from whence their vegetal products are least liable to reach the outflow conduit.

130. Impounding.—When supplying lakes have moderate drainage areas in proportion to the total volume of water required from them, it is then necessary to place the

draught conduit below their natural surface or to raise their natural surface by a dam at their outlet, to avail of their storage, thus in a degree changing their condition of nature into the artificial condition of *impounding reservoirs*.

The theory of volume of supply from given drainage areas (§ 53), and the theory of making available a large proportion of the rainfall by impounding (§ 75), have already been discussed in their appropriate sections.

Important results, affecting the purity of the water, may follow from the disturbance of the long-maintained conditions of the shores, analogous to those of the construction of artificial impounding reservoirs in valleys, by embankments across the outflow streams.

The waves, of natural broad lakes that have but little rise and fall, have long since removed the soil from large portions of their shores, leaving them paved with boulders and pebbles, which the ice, if in northern latitudes, has crowded into close rip-raps, and the removed soil has been deposited in the quiet shallow bays.

Upon the paved shores the lack of vegetable mold and the dash of the waters are obstacles to the growth of vegetation.

131. Plant Growth.—If, under the new conditions, the waters are drawn down in the summer, the wave power reduced, the shallow bottoms of the bays uncovered, and an entire shore circuit of vegetable deposit exposed to the hot sun, a mass of luxuriant vegetation at once springs into existence upon this uncovered bottom, and the greater its thrift the more rapid its decay, and the more objectionable its gaseous emanations that will enter into solution in the water.

Such growths and transformations may continue to repeat themselves through several successive years, and to

some extent continuously. Under the former conditions of deeper water the plant life was of less abundance, of less thrifty growth, and of less rapid decay, and the natural processes of purification were adequate to maintain the natural purity of the water.

Stimulated vegetable growths result in quick decay and the production of vegetable muck, the foulest solid product of vegetable decompositions in water. Slow decompositions of vegetable matter in water rarely affect the water to a noxious degree, and result in the production of a peat deposit almost entirely free from deleterious qualities in the water.

The presence of the fishy or cucumber odor is evidence that the water, or a considerable portion of it, has been too warm for stored potable water; and that there is too much of shallow margin, or that the storage lake has received too much of meadow drainage. It is not, as many have supposed, an evidence of dead fish in the reservoir, but an effect tending to drive the higher orders of the fish more closely about the springs or inflowing streams.

132. Strata Conditions.—The winds assist the ready escape of the odorous gases when they have risen near to the surface, and the stratum of water of greatest purity, in summer, is usually a little below the surface, and would be at the surface were it not for the microscopic organisms that exist there, and the floating matters.

The change of density of water with change of temperature produces a remarkable effect in autumn. Water is at its greatest density at the temperature just above freezing (39°2 Fah.), and when the frosts of autumn chill the surface water it is then heavier than the water below, and sinks, displacing the bottom water; and the vertical circulation, stirring up the whole body, continues until the surface is sealed

by ice, when quiet again reigns at the bottom. This action stirs up the bottom impurities, and often makes them particularly offensive in autumn, even more than in mid-summer.

In the case of new flowage of artificial reservoirs over a meadow bottom, the live vegetable growth has all to go through a certain chemical transformation, the influence of which upon the water is often detectable, for a time, by the sense of smell. This action in the water may be considerably reduced by first burning thoroughly the whole surface, and destroying the organic life and properties, leaving only the mineral ash.

The breaking up of the vegetable fibres, if undestroyed by fire, and their deposition in the quiet, shallow bays, encourages the growth of aquatic plants, and, indirectly, animal life there.

The protection of the shores by high water in winter, and their exposure by drawing down the water in summer, is favorable to aquatic growths upon them, as in the above-mentioned lake examples.

133. Plant and Insect Agencies.—In cases of excessive growths of either or both vegetal and animal life, their products are liable to be drawn into the outflow conduit and the distribution pipes, where their presence becomes disagreeably evident by the gaseous “fishy” or “cucumber” odors liberated when the water is drawn from faucets.

When conditions are favorable for the production of either vegetal or animal life alone, in excessive abundance, disagreeable effects, especially if the excess be animal, are almost certain to follow, since both are among the active agents employed by nature in the purification of water, and natural laws tend to preserve the due balance in their

growth, the one being producers of oxygen and the other of carbon.

Newly flowed collecting or storage reservoirs should be promptly stocked with a fine grade of fish, that will feed upon and prevent the overabundance of the crustacea, which in turn will consume the organic decompositions, and prevent their diffusion through the waters.

134. Preservation of Purity.—General observation teaches that neither vegetation or any species of the infusoria flourish to an objectionable extent in fresh waters in the temperate zone where the depth exceeds about ten feet, though it is true that insects are liable to swarm upon the surface of all waters that arrive at a high temperature. Stored waters, for domestic purposes, ought to have in our American climate, depths of not less than twelve feet.

To insure purity of water, so far as protection from its own products is concerned, it is necessary that the shallow waters be cut off by embankments, or that they be deepened, or that their place be supplied by clean sand or gravel filling, raised to a level above high water. It is frequently advisable, also, that the shores of artificial impounding reservoirs of moderate extent be provided with an equivalent for the natural rip-rap provided by nature around natural lakes.

Each of the above expedients has been successfully adopted by the writer in his own practice.

Fig. 7 is an illustration of the revetment of stone surrounding the reservoir of the Norwich, Conn., water-works. The reservoir in this case is two and one-half miles out from the city, and fills the office of both a gathering and distributing reservoir, for a gravitation supply. Its circumference is two and one-quarter miles, and this revetment protects the shore of the entire circuit. Its height above

FIG. 7.

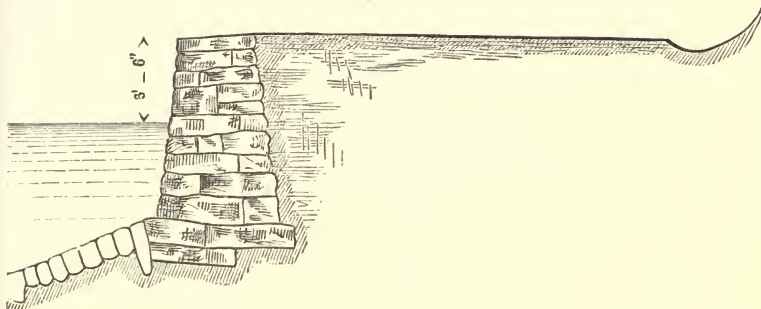

high water, in the vicinity of the dam, is four feet, and in the upper part of the valley three feet.

If the supplying streams of a small lake bring with them much vegetable matter in suspension, and the flow reaches the conduit before complete clarification by natural processes is effected, some method of artificial filtration of the water will be necessary, the details of which will be discussed hereafter.

135. Natural Clarification.—The various sources of chemical impregnation to which waters reaching lakes, usually are subject, whether flowing over or through the earth, have been already herein discussed (§ 101, *et seq.*), so that persons of ordinary intelligence and information may detect them, and form a tolerably accurate estimate of their harmfulness, and if they ought to be considered objectionable when they are to be gathered in a lake and there subjected to the processes in Nature's favorite laboratory of purification.

Waters flowing in the brooks from the wooded hills and the swamps almost always come down to the lakes highly charged with the coloring matter and substances of forest leaves and grasses, and not unfrequently have a very per-

ceptible reddish or chocolate hue. The waters are soon relieved of these vegetable impurities by natural processes in the lake, and their natural transparency and sparkle is restored to them. Sunlight has been credited with a strong influence in the removal of color from water. The chemical transformation already begun upon the hills is continued in the lake, and the atmospheric oxygen aids in releasing the gases of the minutely subdivided vegetable products producing the color, when the mineral residues have sufficient specific gravity to take them speedily to the bottom. The winds are the good physicians that bring the restoring remedies.

Ponds and lakes often receive a considerable part of their supply from springs along their borders, whose waters have received the most perfect natural clarification. Such springs, from quartzose earths, yield waters of the most desirable qualities. *Kelley's Pond, L. S.*

136. Great Lakes.—When lakes, on a scale of great inland seas, like those lining our northern boundary, upon which great marts of trade are developing, are at hand, many of the above supposed conditions belonging to smaller lakes and ponds, are entirely modified.

In such cases the cities become themselves the worst polluters of the pure waters lying at their borders, and they are obliged to push their draught tunnels or pipes beneath the waters far out under the lakes to where the water is undefiled.

This system was inaugurated on a great scale by Mr. E. S. Cheesboro, C.E., for Chicago, and followed by the cities of Cleveland, Buffalo, and with submerged pipe by Milwaukee.

137. Dead Lakes.—The waters of the Sinks, or Dead Lakes of the Utah, Nevada, and southern California, Great

Desert, from which there are no visible outlets, are notable exceptions to general conditions of lake waters. Here the salts gathered by the inflowing waters, for centuries, which evaporating vapors can not carry away, have been accumulating, till the waters are nauseating and repugnant.

The skill of the well-borer must aid civilization when these desert regions are to become generally inhabitable.

RIVER WATERS.

138. Metropolitan Supplies.—Rivers are of necessity the final resort of a majority of the principal cities of the world for their public water supply. The volume of water daily required in a great metropolis often exceeds the combined capacity of all the springs, brooks, and ponds within accessible limits, and supplies from wells become impossible because of lack of capacity, excessive aggregate cost, and the sickening character of their waters.

Since rivers occupy the lowest threads of the valleys in which they flow, their surfaces are lower than the foundations of the habitations and warehouses along their banks.

Their waters have therefore usually to be elevated by power for delivery in the buildings, the expense of conducting their waters from their sufficiently elevated sources being greater far than the capitalized cost of the artificial lift nearer at hand.

The theories by which the minimum flow of the stream (§ 53), and the maximum demand for supply (§ 19), are determined and compared have been already herein discussed; so we now assume that the supplies have, after proper investigation, been determined ample, and also that the geological structure (§ 106) of the drainage area is found to present no impregnating strata precluding the use of its

waters for domestic and commercial purposes, or in the chemical arts.

139. Harmless and Beneficial Impregnations.—

The natural organic impurities of rivers are seldom other than dissolving vegetable fibres washed down from forests and swamps, and these are rarely in objectionable amount; and the natural mineral impurities in solution are usually magnesia, common salt, lime, and iron, and, in suspension, sand and clay. The lime, sand, and clay are easily detectible if in objectionable amount, and the remaining natural mineral impregnation are quite likely to be beneficial rather than otherwise, since they are required in drinking water to a limited extent to render them palatable, and for promotion of the healthy activity of the digestive organs, and the building up of the bones and muscles of our bodies.

140. Pollutions.—We reiterate that it is the *artificial impurities* that are the bane of our river waters. Manufactories, villages, towns, and cities spring up upon the river-banks, and their refuse, dead animals, and sewage are dumped into the running streams, making them foul potions of putrefaction and destruction, when they should flow clear and wholesome according to the natural laws of their creation and preservation.

141. Sanitary Discussions.—The prolific discussion upon the sanitary condition of the water of the river Thames, England, since the report of the Royal Commission of 1850, has brought out a variety of conflicting opinions in regard to the efficiency of natural causes to destroy sewage impurities in water.

About one-half the population of London, or one-half million persons, received their domestic water supply from the Thames in 1875. The drainage area above the pumping stations is about 3675 square miles, and the minimum

summer flow is estimated to be about 350,000,000 imperial gallons daily, and of this flow about 15,000,000 gallons is pumped daily by the water companies. Upon the Thames watershed above the pumping stations there resides a population of about 1,000,000 persons, including three cities of over 25,000 persons each, three cities of from 7000 to 10,000 persons each, and many smaller towns and villages. The whole of the river and its principal tributaries are under the strictest sanitary regulation which the government is able to enforce, notwithstanding which a great mass of sewage is poured into the stream.

Yet it is claimed by eminent authority that the Thames water a short distance above London is wholesome, palatable, and agreeable, and safe for domestic use.

A remark by Dr. H. Letheby, medical officer of health for the city of London until his decease in the spring of 1876, gives a comprehensive summary of the argument in favor of the Thames water, viz.: "I have arrived at a very decided conclusion that sewage, when it is mixed with twenty times its volume of running water and has flowed a distance of ten or twelve miles, is absolutely destroyed: the agents of destruction being infusorial animals, aquatic plants and fish, and chemical oxydation."

Several eminent chemists testify that analyses detect no trace of the sewage in the Thames near London. Sir Benjamin Broodie, Professor of Chemistry in the University of Oxford, remarked in his testimony upon the London water supply: "I should rely upon the dilution quite as much, and more, than upon the destruction of the injurious matter."

Dr. C. F. Chandler, President of the New York Board of Health, and Professor of Chemistry in the School of Mines, Columbia College, has in his own writings quoted

many eminent authorities,* with apparent indorsement of their conclusions, supporting the theory of the wholesomeness and safety of the Thames water as a domestic supply for the city of London.

142. Inadmissible Polluting Liquids.—The Parliamentary Rivers Pollution Committee, when investigating the subject of the discharge of manufacturing refuse and sewage into the English rivers, Mersey and Ribble, and the possibility of the deodorization and cleansing of the refuse by methods then available, suggested † that liquids containing impurities equal to or in excess of the limiting quantity defined by Prof. Frankland (*vide* § 123, p. 137), be deemed polluting and inadmissible into any stream.

143. Precautionary Views.—On the other hand, many physicians, chemists, and engineers, whose scientific attainments give to their opinions great weight, emphatically protest against the adoption or use of a source of domestic water supply that is at all subject to contamination by sewage or putrefying organic matters of any kind.

There are certain laws of nature that have for their object the preservation of human life to its appointed maturity, which we term instinct, as, for instance, involuntary grasping at a support to save from a threatened fall; involuntary raising the arm to protect the eye or head from a blow; involuntary sudden withdrawal of the body from contact with a hot substance that would burn. There is also an instinctive repugnance to receiving any excrementitious or putrefying animal substance, or anything that the eye or sense of smell decides to be noxious, upon the tongue or into the system. It is not safe to overlook or subdue the natural instincts created within us for our preservation.

* Public Health Papers of American Public Health Association, vol. i.

† First Report. R. P. C., 1868, vol. i, p. 130.

Following are a few opinions supporting the cautionary side of the question :

“Except* in rare cases, water which holds in solution a perceptible proportion of organic matter becomes soon putrid, and acquires qualities which are deleterious. It is evident that diarrhœa, dysentery, and other acute or chronic affections have been induced endemically by the continued use of water holding organic matter in large proportions, either in solution or in suspension. It is admitted, as the result of universal observation, that the less the quantity of organic matter held by the water we drink, the more wholesome it is.”

“No † one has conclusively shown that it is safe to trust to dilution, storage, agitation, filtration, or periods of time, for the complete removal from water of disease-producing elements, whatever these may be. Chemistry and microscopy cannot and do not claim to prove the absence of these elements in any specimen of drinking water.”

“It ‡ is a well-received fact, that decomposing animal matter in drinking water is a fertile producer of intestinal diseases.”

Dr. Wolf (in *Der Untergrund und das Frinkwasser der Städte, Erfurt, 1873*) gives a large number of cases, which prove conclusively that “bad water produces diarrhœa, and can propagate dysentery, typhoid fever, and cholera, and that such water is frequently clear, fresh, and very agreeable to the taste.”

Dr. Lyon Playfair, of London, remarks : “The effect of

* Boutron and Boudet. *Annual of French Waters, 1851.*

† Testimony of Dr. R. A. Smith before the Royal Commission of Water Supply of London.

‡ Report of Medical Commission on Additional Water Supply for Boston, 1874.

organic matter in the water depends very much upon the character of that organic matter. If it be a mere vegetable matter, such as comes from a peaty district, even if the water originally is of a pale sherry color, on being exposed to the air in reservoirs, or in canals leading from one reservoir to another, the vegetable matter gets acted upon by the air and becomes insoluble, and is chiefly deposited, and what remains has no influence on health. But where the organic matter comes from drainage, it is a most formidable ingredient in water, and is the one of all others that ought to be looked upon with apprehension when it is from the refuse of animal matter, the drainage of large towns, the drainage of any animals, and especially of human beings."

The Massachusetts State Board of Health, in their fifth annual report, remarking upon the joint use of watercourses for sewers and as sources of water supply for domestic use, remarks: "We believe that all such joint use is to be deprecated. . . . The importance of this matter is underrated for two reasons: first, because of the oft-repeated assertion, made on the authority of Dr. Letheby, 'that if sewage-matter be mixed with twenty times its bulk of ordinary river water, and flow a dozen miles, there is not a particle of that sewage to be discovered by chemical means;' secondly, because of the feeling that to be in any way prejudicial to health, a water must contain enough animal matter to be recognized readily by chemical tests—enough, in fact, to be expressed in figures."

144. Speculative Condition of the Pollution Question.—Sanitary writings have abounded with discussions of this subject during the last decade; still, looking broadly over the field of discussion, it is evident that the leading medical and chemical authorities have not

agreed upon the limit for any case, or class of cases, when water becomes noxious or harmful.

Some of the consumers of the waters of the Thames in England and of the Mystic and Charles rivers in New England, have evinced a remarkable faith in the toughness of human constitutions.

The whole subject of water contamination remains as yet rather physiologically speculative than chemically exact. It is earnestly to be desired that the present experimental practice upon human constitutions, so costly in infantile life, may soon yield a sufficiency of conclusive statistics, or that science shall soon unveil the subtle and mysterious chemical properties of organic matters, at least so far as they are now concealed behind recombinations, reactions, and test solutions.

145. Spontaneous Purification.—The river courses are the natural drainage channels of the lands, and it cannot but be expected that a considerable bulk of refuse, from populous districts, will find its way to the sea by these channels, however strict the sanitary regulations for the preservation of the purity of the streams. Therefore it is a matter of high scientific interest, and in most cases of great hygienic and national importance, to determine what proportion of the organic refuse is destroyed beyond the possibility of harm to animals that drink the water, by spontaneous decomposition, and what proportion remains in solution and suspension.

In ordinary culinary and chemical processes we find that temperature has an important influence upon the dissolving property of water. Water of temperature below 60° Fah. dissolves meats, vegetables, herbs, sugar, or gum, slowly, - comparatively, and a cold atmosphere does not promote decomposition of organic matter. We therefore infer

that a temperature of both atmosphere and water as high, or nearly as high, as 60° Fah. are required to promote rapid oxydation of the organic impurities in water. In winter the process must proceed slowly, and if the stream is covered by ice, be almost suspended. Agitation of the water is absolutely essential to the long-maintained process of oxydation, in order that the water may continue charged with the necessary bulk of oxygen in solution; therefore weirs across the stream, roughness of the bed and banks of the stream, and rapidity of flow are essential elements in rapid oxydation.

Dr. Sheridan Murpratt remarks,* in respect to this spontaneous purification of river waters containing organic matters: "As a general rule, the carbon unites with oxygen to form carbonic acid; and with hydrogen to form marsh gas or carbide of hydrogen; hydrogen and oxygen unite to form water; nitrogen and oxygen with hydrogen to form ammonia; sulphur with hydrogen to form sulphide of hydrogen; phosphorus with hydrogen to form phosphide of hydrogen.

"The latter two are exceedingly offensive to the sense of smell, and are, moreover, highly poisonous. Thus in the spontaneous decomposition of the organic matter contained in water, there are produced carbonic acid, carbide of hydrogen, ammonia, sulphide of hydrogen, and phosphide of hydrogen. These are the *recognized* compounds; but when it is borne in mind that the *gaseous emanations* of decomposing animal matters are infinitely more offensive to the sense of smell and injurious to health than any of the gases above mentioned, or of any combination of them, it can only be concluded that the effluvia of decaying organic

* Chemistry, Theoretical, Practical, and Analytical: Glasgow.

matter contains other constituents, of which the true character has not yet been determined." This chemical purification is assisted by vegetal absorption and animalculine consumption.

146. Artificial Clarification.—While water subjected at all to organic, especially drainage or animal impurities, should be avoided, if possible, for domestic consumption, it should, on the other hand, when necessarily submitted to, be clarified before use, of its solids in suspension, by precipitation, deposition in storage or settling basins, or by one of the most thorough processes of filtration.

147. A Sugar Test of the Quality of Water.—The *Pharmaceutical Journal* quotes Heisch's simple sugar test for water, as follows:

“Good water should be free from color, unpleasant odor and taste, and should quickly afford a good lather with a small proportion of soap.

“If half a pint of the water be placed in a clean, colorless glass-stoppered bottle, a few grains of the best white lump-sugar added, and the bottle freely exposed to the daylight in the window of a warm room, the liquid should not become turbid, even after exposure for a week or ten days. If the water becomes turbid, it is open to grave suspicion of sewage contamination; but if it remain clear, it is almost certainly safe.

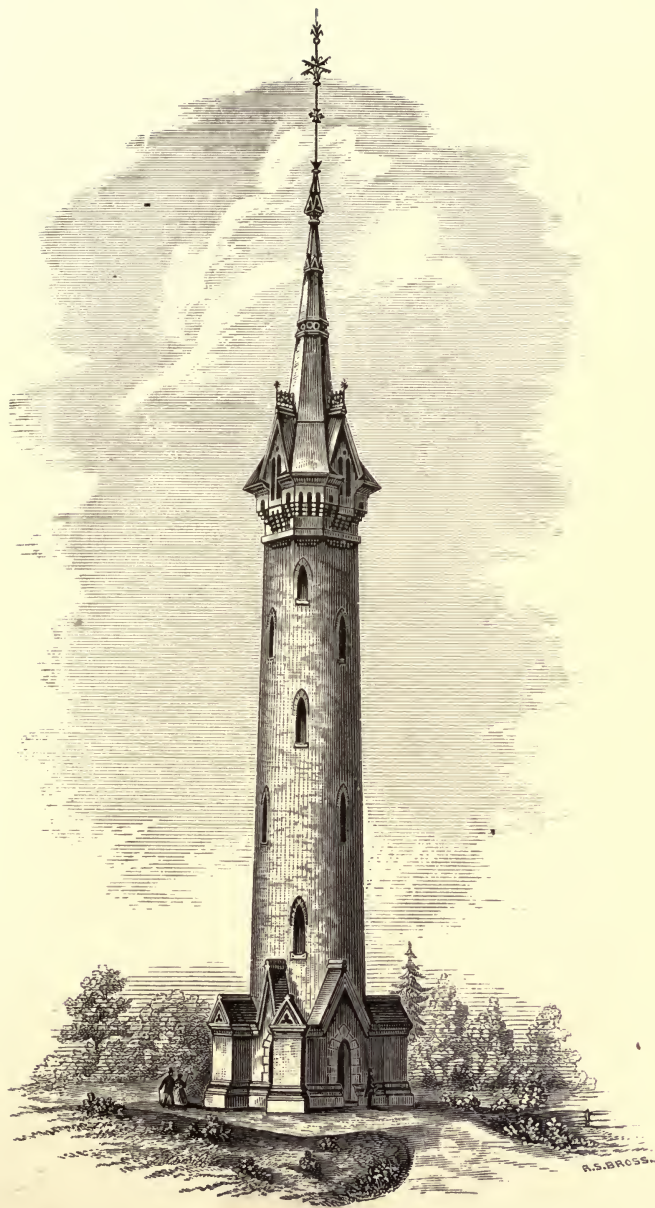

STAND-PIPE, BOSTON.

SECTION II.

FLOW OF WATER THROUGH SLUICES, PIPES AND CHANNELS.

CHAPTER X.

WEIGHT, PRESSURE, AND MOTION OF WATER.

148. Special Characteristics of Water.—If we consider those qualities of water that have reference to its *weight*, its *pressure*, and its *motion*, we shall observe, especially: *That the volume of the liquid is composed of an immense number of minute particles; that each particle has weight individually; that each particle can receive and transmit the effect of weight, in the form of pressure, in all directions; and that the particles move past and upon each other with very slight resistance.*

We are convinced by the sense of touch that the particles of a body of water are minute, and have very little cohesion among themselves or friction upon each other, when we put our hand into a clear pool and find that the particles separate without appreciable resistance; and also by the sense of sight, when we see fishes and insects, and, with the aid of the microscope, the tiny infusoriæ, moving rapidly through the water, without apparent effort greater than would be required to move in air.

149. Atomic Theory.—Ancient records of scientific research inform us that the study of the divisibility and nature of the particles of matter occupied, long ago, the most vigorous minds. It is twenty-two centuries since Democritus explained the atomic theory to his fellow-citizens, and taught them that particles of matter are capable of subdivision again and again, many times beyond the limit perceptible to human senses, but that finally the atom will be reached, which is indivisible, the unit of matter. Anaxagoras, the teacher of Socrates, maintained, on the contrary, that matter is divisible to infinity, and that all parts of an inorganic body, to infinite subdivision, are similar to the whole. This latter theory has not been generally accepted. The whole subject of the nature of matter, in its various conditions, forms, and stages of progress, has maintained its interest through the succeeding centuries, and is to-day a favorite study of philosophers and theme of discussion in lecture halls.

150. Molecular Theory.—Modern research has demonstrated that the unit of water is composed of at least two different substances, and therefore is not an atom. The unit is termed a molecule, and, according to the received doctrine, the foundation of each molecule of water is two molecules of hydrogen and one molecule of oxygen. These latter molecules may possibly be ultimate atoms.

The theory is advanced that each molecule of water is surrounded by an elastic atmosphere, and by a few that it is itself slightly elastic.

Sir William Thompson estimated that between five hundred millions and five thousand millions of the molecules of water may be placed side by side in the space of one lineal inch. To enable us to detect the outline of one of these molecules, our most powerful microscope must have

its magnifying power multiplied as many times again, or squared.

A film of water flowing through an orifice one-hundredth of an inch deep, or about the thickness of this leaf, would be, according to the above estimate, from five to fifty million molecule diameters in depth. It is impossible to comprehend so infinitesimal a magnitude as the diameter of one of these molecules, so we shall be obliged to imagine them so many times magnified as to resemble a mass of transparent balls, like billiard balls, for instance, or similar spheres, and to consider them while so magnified.

151. Influence of Caloric.—There is also a theory, very generally accepted, that the molecules of water, more especially their gaseous constituents, are constantly subject to the influence of caloric, the cause of heat, and are in consequence in incessant compound motion, both vibratory and progressive, and that they are constantly moving past each other, progressing with wavy motion, or are rebounding against each other, and against their retaining vessel.

This motion may be partially illustrated by the motion of a great number of smooth, transparent, elastic balls, in a vessel when the vessel is being shaken. It may be demonstrated by placing a drop of any brilliant colored liquid, for which water has an affinity, into a vessel of quiet water, when the drop will be gradually diffused throughout the whole mass, showing not only that among the molecules of colored liquid there is activity, but that certain of the molecules before in the vessel plunge into and through the drop from all sides, dividing it into parts, and its parts again into other parts, until the particles are distributed throughout the mass.

While the molecules are arranged in crystalline form, they require considerably more space than when in liquid

form, and there are a less number of them in a cubic inch ; therefore a cubic inch of ice weighs less than a cubic inch of water.

152. Relative Densities and Volumes.—The relative changes in weight and volume of water at different temperatures are shown graphically in Fig. 8. When

FIG. 8.

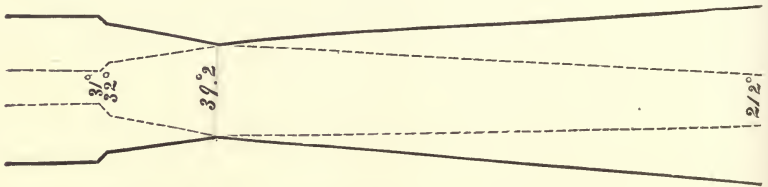

weight is maintained constant and the *temperature* of the water is increased or decreased, the *volume* will change as indicated by the solid lines. When *volume* is maintained constant and the *temperature* increased or decreased, the *weight* will change as indicated by the dotted lines.

WEIGHT OF WATER.

153. Weight of Constituents of Water.—Water is substantially the result of the union (§ 150) of two volumes of hydrogen, having a specific gravity equal to 0.0689, and one volume of oxygen, having a specific gravity equal to 1.102 ; but various other gases that come in contact with this combination are readily absorbed.

Bulk for bulk, the oxygen is sixteen times heavier than the hydrogen. Water at its greatest density is about eight hundred and fifteen times as heavy as atmospheric air.

The density of the vapor or gases enveloping the liquid molecules is greatest at a temperature of about $39^{\circ}.2$ Fah. At this temperature the greatest number of molecules is

contained in one cubic inch, and the greatest weight for a given volume obtains.

As the temperature of water rises from $39^{\circ}.2$, its gaseous elements expand and are supposed to increase their activity; and a less number of molecules can be contained in a cubic inch, or other given volume; therefore the weight of water decreases as the temperature rises from $39^{\circ}.2$ Fah. (*vide* Fig. 8.)

154. Crystalline Forms of Water.—As the temperature falls below $39^{\circ}.2$ Fah., the molecules, under one atmosphere of pressure, incline to arrange themselves in crystalline form, their action is supposed to be more vibratory and less progressive, and they become ice at a temperature of about 32° Fah.

The relative weights and volumes of distilled water at different temperatures on the Fahrenheit scale are shown numerically in the table on the following page.

Although there is a slight difference in the results of experiments of the best investigators in their attempts to obtain the temperature of water at its maximum density, it is commonly taken at 39.2° Fah., and the weight of a cubic foot of water at this temperature as 62.425 pounds, and the weight of a United States gallon of water at the same temperature as 8.379927 pounds.

155. Formula for Volumes at Different Temperatures.—The tables of weights and volumes of water is extended, with intervals of ten degrees, to the extreme limits within which hydraulic engineers have usually to experiment. The intermediate weights and volumes for intermediate temperatures, may be readily interpolated, or reference may be had to the following formulas taken from Watt's "Dictionary of Chemistry," combining the law of expansion as determined by experiments of Matthiessen, Sorby, Kopp, and Rossetti.

TABLE No. 38.

WEIGHT AND VOLUME OF DISTILLED WATER AT DIFFERENT TEMPERATURES.

Temperature Fah.	Weight of a cu. ft. in pounds.	Difference.	Ratio of volume to volume of equal wt. at max. density of temperature, 39.2° Fah.	Difference.
Ice.	57.200916300
32°	62.417	5.217	1.000129	.083829
39.2°	62.425	.008	1.000000	.000129
40°	62.423	.002	1.000004	.000004
50°	62.409	.014	1.000253	.000249
60°	62.367	.042	1.000929	.000676
70°	62.302	.065	1.001981	.001052
80°	62.218	.084	1.00332	.001339
90°	62.119	.099	1.00492	.00160
100°	62.000	.119	1.00686	.00194
110°	61.867	.133	1.00902	.00216
120°	61.720	.147	1.01143	.00241
130°	61.556	.164	1.01411	.00268
140°	61.388	.168	1.01690	.00279
150°	61.204	.184	1.01995	.00305
160°	61.007	.197	1.02324	.00329
170°	60.801	.206	1.02671	.00347
180°	60.587	.214	1.03033	.00362
190°	60.366	.221	1.03411	.00378
200°	60.136	.230	1.03807	.00396
210°	59.894	.242	1.04226	.00419
212°	59.707	.187	1.04312	.00086

Let V = ratio of a given volume of distilled water, at the temperature, T , on Fahrenheit's scale, to the volume of an equal weight, at the temperature of maximum density.

W = weight of a cubic foot of distilled water, in pounds, at any temperature, Fahrenheit.

For temperatures 32° to 70° Fah.

$$V = 1.00012 - 0.000033914 \times (T - 32) + 0.000023822 \times (T - 32)^2 - 0.00000006403 (T - 32)^3.$$

For temperatures above 70°.

$$V = 0.99781 + 0.00006117 \times (T - 32) + 0.000001059 \times (T - 32)^2.$$

$$W = \frac{62.425}{V}$$

156. Weight of Pond Water.—Fresh pond and brook waters are slightly heavier than distilled water, and when not loaded with sediment have, for a given volume, an increased weight equal to from 0.00005 to 0.0001 of an equal volume of distilled water.

157. Compressibility and Elasticity of Water.—The compression of rain-water, according to experimental results of Canton, is 0.000046 and of sea-water 0.000040 of its volume under the pressure of one atmosphere.

According to experiments of Regnault, water suffers a diminution of volume amounting to 48 parts in one million, when submitted to the pressure of one atmosphere, equal to 14.75 pounds per square inch, and to 96 parts when submitted to twice that pressure.

Grassi found the compressibility of water to be 50 parts at 37° Fah., and 44 parts at 127° Fah. in each million parts, with one atmosphere pressure.

A column of water 100 feet high would, according to these estimates, be compressed nearly one-sixteenth of an inch.

The degree of elasticity of fluids was discovered by Canton in 1762. He proved that the volume of liquids diminished slightly in bulk under pressure and proportionally to the pressure, and recovered their original volume when the pressure ceased.

This has been confirmed by experiments of Sturm, Ørsted, Regnault, and others.

PRESSURE OF WATER.

158. Weights of Individual Molecules.—If again we consider the molecules of water magnified, as before explained, we can conceive that *each molecule has its individual weight, and is subject, independently, to the force of gravity.* Consider again the film of water of one-hundredth of an inch in depth, flowing through the orifice of same depth, and imagine the orifice to be magnified also in the same proportion as the molecules have been imagined to be magnified, that is, to five million molecule diameters; then the immense leverage that gravity has, proportionally, upon each molecule to set it in motion and to press it out of the orifice can be conceived, and the reason why there is apparently so little frictional resistance to the passage of the molecules over each other will be apparent.

159. Individual Molecular Actions.—The magnified molecule can also be conceived to be acting independently upon any side of its retaining vessel, or upon any other molecule, with which it is in contact, with the combined weight or pressure of all the molecules acting upon it.

In a volume of fluid, *each molecule presses in any direction from which a sufficient resistance is opposed, with a pressure due to the combined natural pressures of all molecules acting upon it in that direction, and also with the pressure transmitted through them from any exterior force.*

In treatises on hydrostatics, propositions relating to pressures of fluids are commonly stated in some form similar to the following:* “When a fluid is pressed by its own weight, or by any other force, at any point it presses equally in all directions.”

* *Vide* Hutton's Mathematics, Hydrostatics, § 310.

160. Pressure Proportional to Depth.—The pressure of a fluid at any point on an immersed surface, is *in proportion to the vertical depth* of that point below the surface of the fluid ; but not in proportion to variable breadths of the fluid.

In vessels of shapes similar to Fig. 9 and Fig. 10, containing equal vertical depths of water, the pressures on equal areas of the horizontal bottoms are equal ; also the pressures on equal and similar areas of their vertical sides, having their centres of gravity at equal depths, are equal.

FIG. 9.

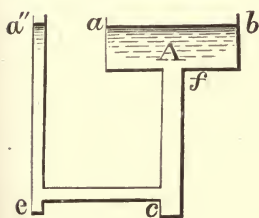
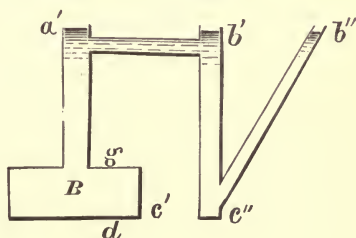

FIG. 10.



161. Individual Molecular Reactions.—Any particle of fluid that receives a pressure *reacts with a force equal to the pressure*, if its motion is resisted upon the opposite side.

Any point of a fixed surface pressed by a particle of water *reacts upon the particle* with a force equal to the pressure of the particle.

The large body of water in the section A of the tank, Fig. 9, is perfectly counterbalanced by the slender body in the section a''. A pressure equal to that due to the weight of all the particles above the horizontal bottom surface, *f*, acts upon that surface, and the surface reacts with an equal pressure and sustains all those particles. The effect would be similar if the surface, or a portion of it, was inclined or curved ; therefore, only a pressure equal to the

weight of those particles vertically over the opening in the partition, f , acts upon the column below the partition f . The right and left horizontal pressures of the individual particles of A are transmitted to the particles on the right and left, which, in turn, react with equal pressures, and sustain them from motion sideways. The particles in contact with the partitions a and b transmit their pressures horizontally to the partition, which in turn react and sustain them, and all the particles remain in equilibrium.

162. Equilibrium Destroyed by an Orifice.—If an orifice is made at the bottom of the side b , then the particles at that point will be relieved of the reaction of the point, or of its support, equilibrium will be destroyed, and motion will ensue, and all the particles throughout A will begin to move toward the orifice, though not with equal velocities.

163. Pressures from Vertical, Inclined and Bent Columns of Water.—In Fig 10 the particles in the body of water, B , are pressed with a pressure due to the weight of any one vertical column of particles or molecules in the body of water above the opening in the partition g , consequently the reaction horizontally from any point in the partition c' , or downward from any point in the covering partition g , or upward from any point in the bottom d , is equal to the weight of a column of molecules pressing upon that point, of height equal to the depth of the given point below the surface of the water $a'b'$. The pressure due to this vertical column of molecules would still remain the same if the column $a'g$ was inclined or bent, so long as the water surface remained in the level $a'b'$, as is evident by inspection of the column b ."

Since the downward reaction from any point in the surface g is equal to the pressure of a column of molecules equal in height to $a'g$, this reaction is added to the action

of gravity on all the molecules beneath the given point in g , therefore the pressure on any point in d , beneath the given point in g , is equal to the pressure of a column of molecules of height $a' d$.

164. Artificial Pressure.—If in the vessel illustrated by Fig. 10, we close the openings b' and b'' at the level of the water surface, and fit a piston carrying a weight into the opening a' , then we will increase the pressure at points d, g, c', b', b'' , etc., respectively, an amount equal to the pressure received by a point in contact with the piston at a' . This artificial pressure is equal in effect to a column of fluid placed upon a' of weight equal to the weight of the loaded piston.

165. Pressure upon a Unit of Surface.—Since one cubic foot of water, measuring 144 square inches on its base and 12 inches in height weighs 62.425 pounds, there must be a pressure exerted by its full bottom area of 62.425 pounds, and by each square inch of its bottom area of $\left(\frac{62.425 \text{ lbs.}}{144 \text{ sq. in.}}\right) = 0.433472$ pounds for each foot of vertical depth of the water.

In ordinary engineering calculations 62.5 pounds is taken as the weight of one cubic foot of water, and 0.434 pounds as the resulting pressure per square inch for each vertical foot of depth below the surface of the water. These weights used in the computation of the following table, give closely approximate results, slightly in excess of the true weights.

In nice calculations, as for instance, relating to tests of turbines to determine their useful effect, or of pumping engines to determine their duty, the weights due to the measured temperatures of the water are to be taken.

TABLE No. 39.

PRESSURES OF WATER AT STATED VERTICAL DEPTHS BELOW THE SURFACE OF THE WATER, AT TEMP. 39.2° FAH.

DEPTH.	PRESSURE PER SQ. INCH.	PRESSURE PER SQ. FOOT.	DEPTH.	PRESSURE PER SQ. INCH.	PRESSURE PER SQ. FOOT.
<i>Feet.</i>	<i>Pounds.</i>	<i>Pounds.</i>	<i>Feet.</i>	<i>Pounds.</i>	<i>Pounds.</i>
1	.4335	62.425	36	15.60	2247.30
2	.8670	124.85	37	16.04	2309.72
3	1.300	187.27	38	16.47	2372.15
4	1.734	248.70	39	16.91	2434.57
5	2.167	312.12	40	17.34	2497.00
6	2.601	374.55	41	17.77	2559.42
7	3.035	436.97	42	18.21	2621.85
8	3.468	499.40	43	18.64	2684.27
9	3.902	561.82	44	19.07	2746.70
10	4.335	624.25	45	19.51	2809.12
11	4.768	686.67	46	19.94	2871.55
12	5.202	749.10	47	20.37	2933.97
13	5.636	811.52	48	20.81	2996.40
14	6.069	873.95	49	21.24	3058.82
15	6.503	936.37	50	21.67	3121.25
16	6.936	998.80	60	26.01	3745.5
17	7.370	1061.23	70	30.35	4370
18	7.803	1123.65	80	34.68	4994
19	8.237	1186.07	90	39.01	5618
20	8.670	1248.50	100	43.35	6242.5
21	9.104	1310.92	110	47.68	6867
22	9.537	1373.35	120	52.02	7491
23	9.971	1435.77	130	56.36	8115
24	10.40	1498.20	140	60.69	8739
25	10.84	1560.62	150	65.03	9364
26	11.27	1623.05	160	69.36	9988
27	11.70	1685.47	170	73.70	10612
28	12.14	1747.90	180	78.03	11237
29	12.57	1810.32	190	82.36	11861
30	13.00	1872.75	200	86.70	12485
31	13.44	1935.17	210	91.04	13109
32	13.87	1997.60	220	95.37	13733
33	14.31	2060.02	230	99.71	14358
34	14.74	2122.45	240	104.04	14982
35	15.17	2184.87	250	108.37	15606

166. Equivalent Forces.—In many computations in elementary statics we are accustomed to consider the force

acting from a *weight* as equivalent to the force of a pressure and to place weights to represent statical forces.

On one square foot of the bottom of a vessel containing one foot depth of water, a pressure is exerted by the water that would tend to prevent any other force from lifting up that bottom. We might remove that water and substitute the pressure of a quantity of oil, or of stone, or of iron, as an equivalent for the pressure of the water, but to be an exact equivalent its weight must be exactly the same as the weight of the water. In this case we should take for the 62.5 pounds pressure in the water, 62.5 pounds weight of oil, or of stone, or of iron.

167. Weight a Measure of Pressure.—Weight is, then, a standard whose unit is one pound, by which pressures may be compared and measured.

FIG. 11.

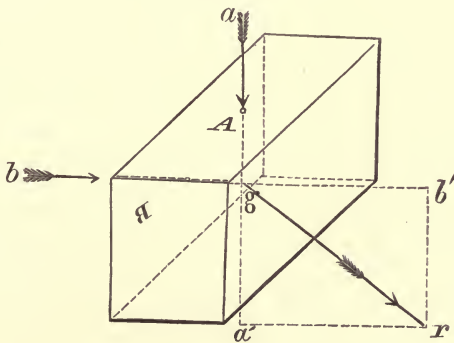

168. A Line a Measure of Weight.—In graphical statics we are also accustomed to represent weights by *lines* which are drawn to some scale.

If two forces act upon the centre of gravity of a body, Fig. 11, one of which, a , is equal to 30 pounds, and the other b , to 40 pounds, we can, after adopting some scale,

say one inch, to equal one pound, represent the force a by a line 30 inches long, drawn from some given point, g , in its direction of action, ga' , and the force b by a line 40 inches long, drawn from the same point, in its direction, gb' . Now, if we draw lines from the end of each line thus produced parallel to the other line to r , completing the parallelogram, and then draw the diagonal, gr , then the *resultant* of the two forces will pass through the line gr , and the length of gr will represent the combined effect of the two forces in this direction. Its length will be 50 inches $= \sqrt{(gb')^2 + (b'r)^2}$, and the combined effect of the two forces in this direction will be 50 pounds.

169. A Line a Measure of Pressure upon a Surface.—Let the dimensions of the top surface of the body A , be 10 feet long and 3 feet wide, and its area be 30 square feet; let the side dimensions, B , be 10 feet long and 4 feet high, and its area be 40 square feet; let the pressure upon each surface be one pound per square foot, and the direction of the pressure be shown by the arrows a and b . The body being solid, the forces are to be considered as acting through its centre of gravity. We can now plot the pressure upon A of 30 pounds in its direction, and upon B of 40 pounds in its direction, and the diagonal of the parallelogram gr will give the direction and ratio of the resultant, as before. The forces being equal to those before considered as acting upon a point, will again give a diagonal 50 inches long and indicating an effect of 50 pounds.

It is plain, then, that we can take the line ga' , or the line $b'r$, which is equal to it, to represent the force or pressure a acting upon the point g or upon the surface A ; and we can take the line gb' , or the line $a'r$, to represent the force or pressure b acting upon the point g or the surface B , and the line gr to represent the combined effect of the two

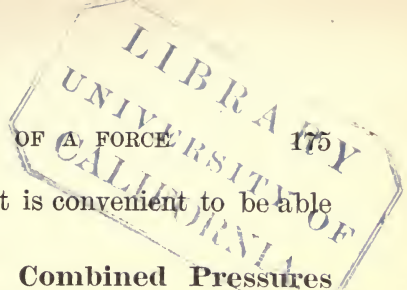

forces. In various calculations it is convenient to be able to do this.

170. Diagonal Force of Combined Pressures Graphically Represented.—Again, if we know the magnitude of the force r acting through the centre of the body, and we desire to know the magnitude of the effects upon the sides A and B , in directions at right angles to them, that produced the force r , we draw the line r to a scale in the direction the force acts, and from both of its ends draw lines to the same scale in directions at right angles to the sides A and B , and proportional to their areas, as ga' and gb' , and complete the parallelogram; then will ga' measured to scale indicate the effect of the force a upon A , and gb' measured to scale indicate the force b upon B . If gr measures 50 pounds, then will ga' measure 30 pounds and gb' measure 40 pounds.

171. Angular Resultant of a Force Graphically Represented.—If a force represented by the line ag , Fig. 12, acts upon and at right angles to an inclined surface fe at g , then its horizontal resultant will be represented by the line bg , and the end b will be perpendicularly beneath a . The ratios of the lengths of the lines ag and ab and bg are the ratios of the effects of the force in their three directions respectively.

FIG. 12.

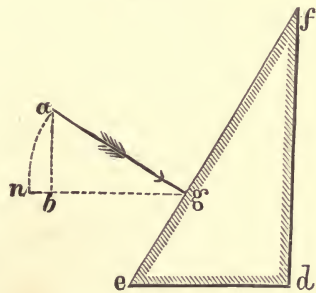

If a perpendicular line be let fall from f upon the horizontal line ed , intersecting it in d , then the ratio of fe to fd will be equal to the ratio of ag to bg ; consequently, the horizontal pressure or effect of the force ag upon fe would be to its direct effect as fd is to fe . Therefore, the ratio of

the line fd to fe equals the ratio of the *horizontal* effect of the *direct* force upon fe .

The ratio of the *vertical* downward effect of the force a upon fe is to its direct effect as the length ab to the length ag , and also as the length ed to the length ef . Therefore, the ratio of the line or surface ed to the line fe represents the ratio of the *vertical* downward effect of the direct force upon fe .

172. Angular Effects of a Force Represented by the Sine and Cosine of the Angle.—Also, ab is the sine, and bg the cosine of the angle agn , and we have seen that their ratios are to radius ag as ed and fd are to fe ; therefore the vertical and horizontal effects of the force a upon the inclined surface fe are to its direct force as the sine and cosine of the angle efd is to radius fe .

173. Total Pressure.—To find the *total* pressure of quiet water on any given surface: *Multiply together, its area, in square feet; the vertical depth of its centre of gravity, below the water surface, in feet; and the weight of one cubic foot of water in pounds (= 62.5 lbs.).*

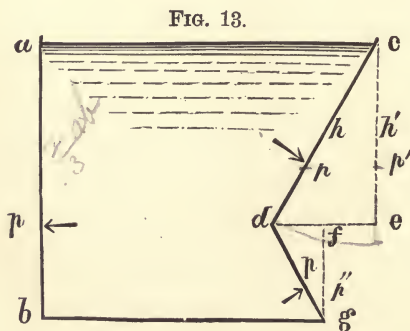

In the tank, Fig. 13, filled with water, let the depth ab be 9 feet; then the centre of gravity of the surface ab will be at a depth from a equal to one-half $ab = 4\frac{1}{2}$ feet. If the length of the side ab

is 1 foot, then the total pressure on ab will equal

$$9 \text{ ft.} \times 1 \text{ ft.} \times 4\frac{1}{2} \text{ ft.} \times 62.5 \text{ lbs.} = 2531.25 \text{ lbs.}$$

174. Direction of Maximum Effect.—The *direction of the maximum effect* of a pressure on a plane surface is

always *at right angles to the surface*. The maximum horizontal effect of the pressure on the unit of length of ab equals the product of ab , into the depth of its centre of gravity, into the unit of pressure. The horizontal effect of pressure on the unit of length of cd equals the product of its vertical projection ce , into the depth of its centre of gravity, into the unit of pressure; and the vertical effect of pressure on cd equals the product of its horizontal projection de , into the depth of its centre of gravity, into the unit of pressure.

175. Horizontal and Vertical Effects.—Assuming the length of the side cd to be radius of the angle dce , then the total pressure on cd is to its horizontal effect as radius cd is to the cosine ce of the angle dce , or as the surface cd is to its vertical projection ce ; and the total pressure is to its vertical effect as radius cd is to the sine de of the same angle, or as cd to de .

The *total pressure* on dg is to its *horizontal effect* as dg is to fg , or to the cosine of the angle dgf ; and to its *vertical effect* as dg to df , or to the sine of the angle dgf .

176. Centers of Pressure and of Gravity.—The *centre of hydrostatic pressure*, which tends to overturn or push horizontally the surface of equal width, ab , is not in the center of gravity of that surface, but in a point at two-thirds the depth from a at $p = 6$ feet.

The center of gravity of the surface cd is at one-half the vertical depth ce , at h' , or at one-half the length of the slope cd , at h . The points h and h' are both in the same horizontal plane. When the water surface is at ac , the center of pressure of the surface cd is at two-thirds of the vertical depth ce , at p' , or at two-thirds the slope cd , at p . The points p' and p are in the same horizontal plane. If ce equals six feet, then the center of gravity of cd or ce will be

at the vertical depth of *three* feet = ch' , and the center of pressure at the vertical depth of *four* feet = cp' .

The center of gravity of the surface dg is at a depth from the water surface c , equal to the sum of one-half the vertical depth fg added to the depth $ce = ce + \frac{fg}{2}$, and the center of pressure of dg is at a vertical depth equal to $\frac{2}{3} \frac{(cg)^3 - (ce)^3}{(cg)^2 - (ce)^2} = cp'' = 7.6$ feet.

177. Pressure upon a Curved Surface and Effect upon its Projected Plane.—In a vessel, Fig. 14, filled with water, one of whose ends, ab , is a segment of a cylinder, and opposite end in

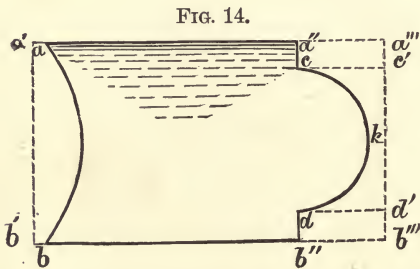

part of the vertical plane $a''b''$, and in part of a hemisphere cd , the total pressure on ab will be as the total surface ab ; but its horizontal effect will be as the area of its

vertical projection $a'b'$. The total pressure on the end $a''b''$, will be as the remaining surface of the vertical plane $a''b''$, increased by the concave surface of the hemisphere ckd , but its horizontal effect will be equal to its vertical projection $a'''b'''$ or $a'b'$. The vertical effect on the plane $a''b''$ is equal to zero, but the vertical effect of the pressure in the hemisphere is represented by the plan of one-half a sphere of diameter equal to cd .

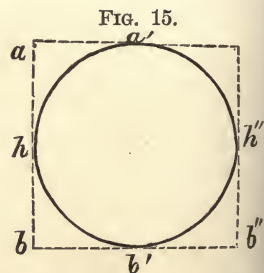

In a hollow sphere, Fig. 15, filled with water, the total pressure will be as the total concave surface $a'hb'h''$, but the horizontal

effect will be as its vertical projection ab , which represents a circular vertical plane of diameter equal to ab , and the vertical effect will be as its horizontal projection bb'' , which represents a horizontal circular area of diameter equal to bb'' .

In a pipe, or cylinder, represented also in section by Fig. 15, the total pressure within is as the inner circumferential area $a'hb'h''$, and when the cylinder lies horizontally the horizontal and vertical effects of its pressure in a unit of length will be represented by its vertical and horizontal projections ab and bb'' .

If the cylinder is inclined, the pressure at any point upon its circumference is as the depth of that point below the surface of the water, and the total pressure in pounds upon any section of the cylinder will be found by multiplying its area in square feet into the depth of its center of gravity, in feet, below the surface of the water and their product into the weight, in pounds (62.5 lbs.), of a cubic foot of water.

178. Center of Pressure upon a Circular Area.—

The center of pressure of a vertical circular area, represented also by Fig. 15, when its top a is in the water surface, is at a depth below a equal to five-fourths the radius of the circle.

179. Combined Pressures.—The sum of pressures in pounds, upon a number of adjacent surfaces, may be found by multiplying the sum of their surfaces in square feet into the depth of their common center of gravity, in feet, below the surface of the water, and this product into the weight of one cubic foot of water, in pounds (62.5 lbs.).

180. Sustaining Pressure upon Floating and Submerged Bodies.—The pressure tending to sustain a cylinder floating vertically in water c (Fig. 16) is equal to

FIG. 16.

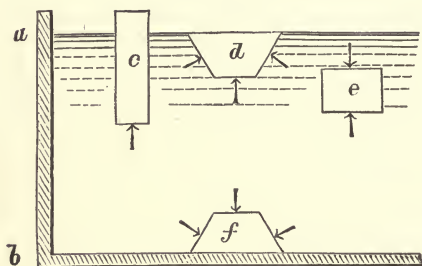
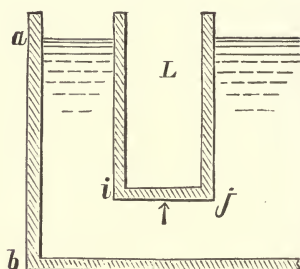

FIG. 17.



the vertical effect of the pressure on its bottom area. The sustaining pressure may be computed, in pounds, by multiplying the bottom area of the cylinder, in square feet, into its depth, in feet (which gives the cubical contents of the immersed portion of the cylinder), and this product into the weight of a cubic foot of water.

The weight of water displaced may be computed also by multiplying the cubic contents of the immersed portion of the cylinder, in cubic feet, into the weight of a cubic foot of water. The two results will be equal to each other; therefore the vertical effect tending to sustain the cylinder is equal to the weight of water displaced.

To compute the pressure tending to sustain the truncated cone, or pyramid, *d*, multiply the vertical projection of the inclined surfaces (= top area — bottom area), in feet, into the depth of their common center of gravity, in feet, and to this product add the product of its bottom area, in feet, into its depth, in feet, and then multiply the sum of the products into the weight of a cubic foot of water, in pounds.

This sustaining pressure will also equal the weight of the water displaced.

To compute the pressure tending to sustain the immersed cube *e*, multiply, in terms as before, the bottom

area into the depth and into the weight of water, and from the final product subtract the product of the top area into its depth and into the weight of water. This sustaining pressure also equals the weight of water displaced.

The downward pressure on the top of e tends to sink it, and the upward pressure on its bottom to sustain it. The difference of the two effects is the resultant. The resultant will act vertically through the center of gravity of the body. If e is of the same specific gravity as the water, then its weight will just balance the resultant, and it will neither rise or fall; if of less specific gravity it will rise; if of greater, it will sink. The cylinder c is evidently of less specific gravity than the water, and d of the same specific gravity.

Let c be a hollow cylinder with a water-tight bottom, then although it may be made of iron, and weights be placed within it, it will still float if its total weight, including its load, is less than the weight of the water it displaces. On the same principle iron ships float and sustain heavy cargoes.

181. Upward Pressure upon a Submerged Lintel.—If L , Fig. 17, be a horizontal lintel covering a sluice between two reservoirs, the upward pressure of the water upon ij , tending to lift it, will be equal to the product of the rectangular area ij into its depth and into the weight of a cubic foot of water; that is, the upward pressure in pounds will be equal to the weight in pounds of a prism of water having the rectangular area ij for its base and the depth of ij below the surface of the water for its height.

If the lintel is constructed of timber, at a considerable depth, and is not equally as strong as the enclosing walls of the reservoir at the same depth, it may be broken in or thrust upward.

182. Atmospheric Pressure.—Upon the particles of all bodies of water resting in open vessels or reservoirs,

FIG. 18.

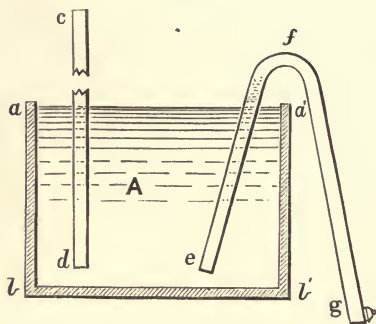

there is a force constantly acting, in addition to the direct force of gravity, upon the independent particles. This force comes from the effect of gravity upon the atmosphere. The weight of the atmosphere produces a pressure upon the surface of the water of about 14.75 pounds per square

inch, or about 2124 pounds per square foot. This is equivalent to a column of water $\left(\frac{14.75 \text{ lbs.}}{0.433472 \text{ ft.}} =\right)$ 34.028 feet high.

In the open vessel, Fig. 18, filled with water to the level *a*, the effect of the pressure of the atmosphere is transmitted through the particles, and acts on all the interior surface below the water surface *abb'a'*, with a force of 14.75 pounds on every square inch, in addition to the pressure from the weight of the water. There is also an equal atmospheric pressure on the exterior of the vessel of 14.75 pounds per square inch; therefore the resultant is zero, and the weight of the atmosphere does not tend to move either side of the vessel or to tear the vessel asunder.

183. Rise of Water into a Vacuum.—If the tube *cd* be extended to a height of thirty-five or more feet above the surface of the water, and a piston, containing a proper valve, be closely fitted in its upper end, then by means of the piston the air may be pumped out of the tube, and the surface of water in the tube relieved of atmospheric pressure. The equilibrium of the particles within the tube will then be de-

stroyed, and the pressure of the atmosphere acting through the particles in the lower end of the tube will press the water up the tube to a height, according to the perfection of the vacuum, of 34.028 feet approximately. It is atmospheric pressure that causes pump cylinders to fill when they are above the free surface of the water.

If the bottom of the immersed tube, cd , be closed by a valve, and the tube filled with water, and the top then sealed at a height of thirty-five or more feet above the surface of the water aa' , the valve at d may afterwards be opened, and the pressure of the atmosphere acting through the particles in the lower end of the tube will sustain the column to a height of 34.028 feet approximately.

184. Siphon.—If the bent tube or siphon, efg , Fig. 18, having its leg fg longer, vertically, than its leg ef , be filled with water and its end e inserted in the water A , then the action of gravity upon the water in the leg fg , will be greater than upon the water in the leg ef , and the equilibrium in the particles at f will be destroyed. The pressure of the atmosphere on the surface aa' , will constantly press the water A up the leg ef , tending to restore the equilibrium, and gravity acting in the leg fg will as constantly tend to destroy the equilibrium, consequently there will be a constant flow of the water A out of the end g , until the water surface falls nearly to the level e , or until the air can enter at e .

185. Transmission of Pressure to a Distance.—*The effect of pressure on a fluid is transmitted through its particles to any distance, however indefinitely great, to the limit of its volume.*

If water is poured into the open top b'' , Fig. 10, the division $b'c''$, will fill as fast as the division b'' , and the water will flow over $b'g$, and will reach the level a' , at approxi-

mately the same time as it reaches b'' ; so in any inverted siphon, or in a system of water pipes of a town, water will in consequence of transmitted pressure, flow from an elevated source down through a valley and up on an opposite hill to the level of the source. If the syphon, or pipe, has an indefinite number of branches with open tops as high as the source, then the surface of the water at the source and in each of the branches will rest in the same relative elevation of the earth's curvature.

186. Inverted Siphon.—By transmission of pressure through the particles, water in a pool or lake near the summit of one hill or mountain is sometimes, when the rock strata have been bent into a favoring shape, forced through a natural subterranean inverted siphon, and caused to flow out as a spring on an opposite hill or mountain summit.

187. Pressure Convertible Into Motion.—Thus we see that the force of gravity in the form of weight is convertible into pressure, and pressure into motion; and that motion may be converted into pressure, and pressure be equivalent to weight.

Motion we are accustomed to measure by its rate, which we term its velocity; that is, the number of units of space passed over by the moving body in a unit of time, as, feet per second.

MOTION OF WATER.

188. Flow of Water.—*All forces tending to destroy equilibrium among the particles of a body of water tend to produce motion in that body.*

We have above referred to the accepted theory of motion due to the influence of caloric; there is a motion of water due to the winds, a motion due to the attraction of the heavenly bodies, and an artificial motion, as, for instance,

that due to the pressure of a pump-piston. The motion herein to be considered is that originated by the influence of gravity and termed the *flow* of water.

189. Action of Gravity upon Individual Molecules.—*All natural flow of water is due to the force of gravity, acting upon and generating motion in its individual molecules.*

If in the side of a vessel filled with water there be made an orifice; if one end of a level pipe filled with water be lowered; or if a channel filled with water have its water released at one end, then equilibrium among the particles of the water will be destroyed, and motion of the water will ensue. Gravity is the force producing motion in either case, and it acts upon each individual molecule as it acts upon a solid body, free to move, or devoid of friction.

190. Frictionless Movement of Molecules.—The molecules of water move over and past each other with such remarkable ease that they have usually been considered as devoid of friction.

The formulas in common use for computing the velocity with which water flows from an orifice in the bottom or side of a tank filled with water, assume that the individual molecules, at the axis of the jet, will issue with a velocity equal to that the same molecules would have acquired if they had fallen freely, in vacuo, in obedience to gravity, from a height above the orifice equal to the height of the surface of the water.

191. Acceleration of Motion.—The force of gravity perpetually gives *new impulse* to a falling body and *accelerates its motion*, if unresisted, *in regular mathematical proportion.*

Experiment has shown that a solid body falling freely in *vacuo*, at the level of the sea, passes through a space or

height of 16.1 feet nearly, during the first second of time; has a velocity at the end of the first second of 32.2 feet nearly, and is accelerated in each succeeding second 32.2 feet nearly. The usual symbol of this rate of acceleration is g , the initial of the word *gravity*, and we shall have frequent occasion for its use.

The latitude and altitude, or distance from the centre of the earth, affects the rate of motion slightly, but does not affect materially the results of ordinary hydrodynamic calculations.

The resistance of the air affects slightly the motion of dense bodies, and retards them more if they are just separating, as water separates into spray.

192. Equations of Motion.—The velocity, v , acquired by a solid body at the end of any time, t , equals the product of time into its acceleration by gravity, g , and is directly proportional to the time :

$$v : g :: t : 1, \quad \text{or} \quad v = gt.$$

The height, h , through which the body falls in one second of time equals $\frac{1}{2}g$, and the heights in any given times, t , are as the squares of those times :

$$h : \frac{1}{2}g :: t^2 : (1)^2, \quad \text{or} \quad h = \frac{1}{2}gt^2;$$

and, by transposition, we have

$$t = \sqrt{\frac{2h}{g}}.$$

This value of t in the equation of v gives

$$v = g\sqrt{\frac{2h}{g}} = \sqrt{2gh}.$$

From these equations we deduce the following general equations of *time*, t ; *height*, h ; *velocity*, v ; and *acceleration*, g :

$$t = \frac{v}{g} = \frac{2h}{v} = \sqrt{\frac{2h}{g}} = .031063v \tag{1}$$

$$h = \frac{gt^2}{2} = \frac{v^2}{2g} = \frac{tv}{2} = .015536v^2 \tag{2}$$

$$v = gt = \frac{2h}{t} = \sqrt{2gh} = 8.0227\sqrt{h} \tag{3}$$

$$g = \frac{v}{t} = \frac{2h}{t^2} = \frac{v^2}{2h} = 32.1908 \tag{4}$$

The *time*, *space*, and *velocity* are at the ends of the first ten seconds as follows :

Time (<i>t</i>).....	1	2	3	4	5	6	7	8	9	10
Space (<i>h</i>).....	16.1	64.4	144.9	257.6	402.5	579.6	788.9	1030.4	1304.1	1600
Velocity (<i>v</i>).....	32.2	64.4	96.6	128.8	161.0	193.2	225.4	257.6	289.8	322
Acceleration (<i>g</i>).....	32.2	32.2	32.2	32.2	32.2	32.2	32.2	32.2	32.2	32.2

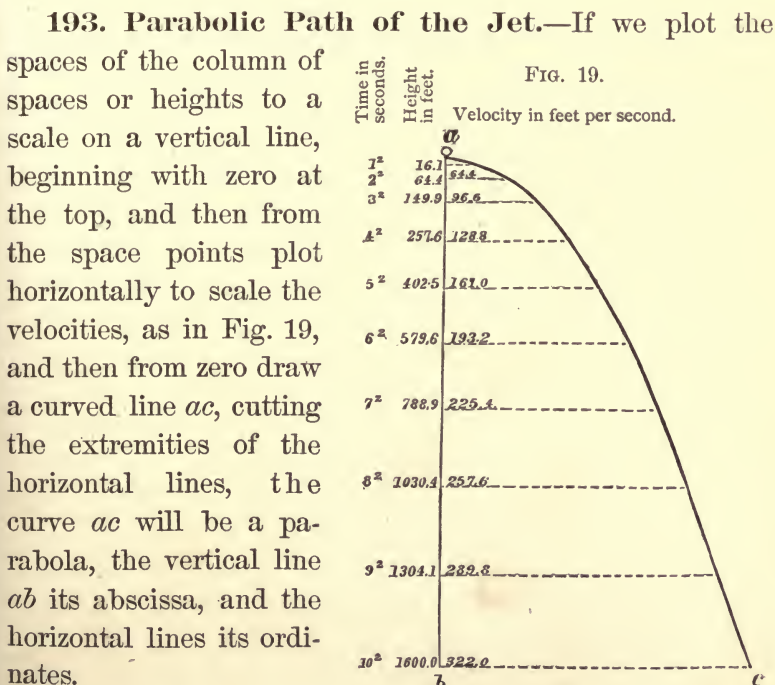

194. Velocity of Efflux Proportional to the Head.

—If in the several sides of a reservoir *A*, Fig. 19*a*, kept filled with water, orifices with thin edges are made at depths of 20 feet, 25 feet, 50 feet, 75 feet, and 100 feet from the surface of the water, then water will issue from each

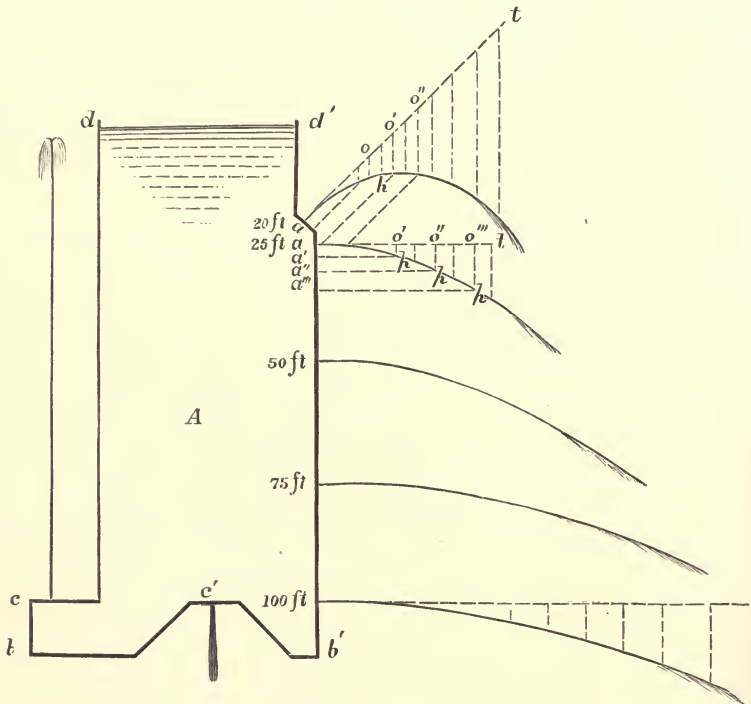
FIG. 19*a*.

orifice in a direction perpendicular to the side, with a velocity proportional to the square root of the head of water above the centre of gravity of the orifice, and equal approximately to the velocity one of its particles would have acquired if it had fallen freely from the height of the head.

195. Conversion of the Force of Gravity from Pressure into Motion.—The accumulated vertical force of gravity due to the head or “charge” will act upon the

particles as pressure before the orifice is opened, but instantly upon an orifice being opened pressure will impel the particles of water in the direction of the axis of the orifice, and gravity will begin anew to act upon the particles in a vertical direction. If the axis of the orifice is not vertical, gravity will deflect the particles through a curved path.

196. Resultant Effects of Pressure and Gravity upon the Motion of a Jet.—If on a line at , drawn through the center of an orifice, perpendicular to the plane of the orifice, we plot to scale the products of any given times into a given velocity, and from each of the points thus indicated we plot vertically downward the distance a body will fall freely in those times, op , and then from the orifice draw a line through the extremities of the vertical lines, the curved line thus sketched will indicate the path of the jet flowing from the orifice. The curved line is a parabola, to which the axis of the orifice is tangent; and the distances ao upon the tangent are equal and parallel to ordinates, and represent the force per unit of time given to the particles of the jet by pressure, and the verticals from the tangent are equal and parallel to abscisses, and represent by their increase the accelerating effect of gravity upon the falling particles. The distances ao and op , ordinates ap , and abscisses aa' , form a series of parallelograms, one angle of which lies in the orifice and the opposite angles of which lie in the curved path of the jet, and the diagonals of which are equal to resultants of the effects of pressure and gravity.

197. Equal Pressures give Equal Velocities in all Directions.—The velocities of issues, downward from the orifice c' and upward from the orifice c , and horizontally from the lower orifice b' , will be equal, since they all are at the same depth.

198. Resistance of the Air.—Since the velocity of upward issue from c is due to the gravity force of the head dc , acting as pressure, the jet should theoretically reach the level of the water surface d . The spreading of the particles and consequent enhanced resistance of the air prevents such result, and the resistance increases as the ratio of area of orifice to height of head decreases.

199. Theoretical Velocities.—The following table of *theoretical velocities* and *times* due to given heights or *heads* has been prepared to facilitate calculation :

TABLE NO. 40.

CORRESPONDENT HEIGHTS, VELOCITIES, AND TIMES OF FALLING BODIES.

$H = \frac{v^2}{2g}$	$v = \sqrt{2gH}$	$t = \frac{\sqrt{2H}}{g}$	$H = \frac{v^2}{2g}$	$v = \sqrt{2gH}$	$t = \frac{\sqrt{2H}}{g}$
Head in feet.	Velocity in feet per second.	Time in seconds.	Head in feet.	Velocity in feet per second.	Time in seconds.
.010	.80	.0248	.145	3.05	.0949
.015	.98	.0304	.150	3.11	.0964
.020	1.13	.0350	.155	3.16	.0980
.025	1.27	.0394	.160	3.21	.0995
.030	1.39	.0431	.165	3.26	.1011
.035	1.50	.0465	.170	3.31	.1016
.040	1.60	.0496	.175	3.36	.1042
.045	1.70	.0527	.180	3.40	.1054
.050	1.79	.0555	.185	3.45	.1069
.055	1.88	.0583	.190	3.50	.1085
.060	1.97	.0611	.195	3.55	.1100
.065	2.04	.0632	.20	3.59	.1113
.070	2.12	.0657	.21	3.68	.1141
.075	2.20	.0682	.22	3.76	.1166
.080	2.27	.0704	.23	3.85	.1193
.085	2.34	.0725	.24	3.93	.1221
.090	2.41	.0747	.25	4.01	.1243
.095	2.47	.0766	.26	4.09	.1268
.100	2.54	.0787	.27	4.17	.1293
.105	2.60	.0806	.28	4.25	.1317
.110	2.66	.0825	.29	4.32	.1339
.115	2.72	.0843	.30	4.39	.1361
.120	2.78	.0862	.31	4.47	.1386
.125	2.84	.0880	.32	4.54	.1407
.130	2.89	.0896	.33	4.61	.1429
.135	2.95	.0914	.34	4.68	.1451
.140	3.00	.0930	.35	4.75	.1472

CORRESPONDENT HEIGHTS, VELOCITIES, AND TIMES OF FALLING
BODIES—(Continued.)

$H = \frac{v^2}{2g}$	$v = \sqrt{2gH}$	$t = \frac{\sqrt{2H}}{g}$	$H = \frac{v^2}{2g}$	$v = \sqrt{2gH}$	$t = \frac{\sqrt{2H}}{g}$
Head in feet.	Velocity in feet per second.	Time in seconds.	Head in feet.	Velocity in feet per second.	Time in seconds.
.36	4.81	.1491	.83	7.31	.2266
.37	4.87	.1510	.84	7.35	.2278
.38	4.94	.1531	.85	7.40	.2294
.39	5.01	.1553	.86	7.44	.2306
.40	5.07	.1572	.87	7.48	.2319
.41	5.14	.1593	.88	7.53	.2334
.42	5.20	.1612	.89	7.57	.2347
.43	5.26	.1634	.90	7.61	.2359
.44	5.32	.1649	.91	7.65	.2377
.45	5.38	.1668	.92	7.70	.2387
.46	5.44	.1686	.93	7.74	.2399
.47	5.50	.1705	.94	7.78	.2412
.48	5.56	.1724	.95	7.82	.2424
.49	5.62	.1742	.96	7.86	.2437
.50	5.67	.1758	.97	7.90	.2449
.51	5.73	.1779	.98	7.94	.2461
.52	5.79	.1795	.99	7.98	.2474
.53	5.85	.1813	1.	8.03	.2491
.54	5.90	.1829	1.02	8.10	.2518
.55	5.95	.1844	1.04	8.18	.2543
.56	6.00	.1860	1.06	8.26	.2567
.57	6.06	.1879	1.08	8.34	.2589
.58	6.11	.1894	1.10	8.41	.2616
.59	6.17	.1913	1.12	8.49	.2638
.60	6.22	.1928	1.14	8.57	.2660
.61	6.28	.1947	1.16	8.64	.2685
.62	6.32	.1959	1.18	8.72	.2706
.63	6.37	.1975	1.20	8.79	.2730
.64	6.42	.1990	1.22	8.87	.2751
.65	6.47	.1999	1.24	8.94	.2774
.66	6.52	.2021	1.26	9.01	.2797
.67	6.57	.2037	1.28	9.08	.2819
.68	6.61	.2049	1.30	9.15	.2842
.69	6.66	.2065	1.32	9.21	.2866
.70	6.71	.2080	1.34	9.29	.2885
.71	6.76	.2096	1.36	9.36	.2906
.72	6.81	.2111	1.38	9.43	.2927
.73	6.86	.2127	1.40	9.49	.2950
.74	6.91	.2142	1.42	9.57	.2968
.75	6.95	.2154	1.44	9.63	.2991
.76	6.99	.2167	1.46	9.70	.3010
.77	7.04	.2182	1.48	9.77	.3030
.78	7.09	.2198	1.50	9.83	.3052
.79	7.13	.2210	1.55	9.98	.3106
.80	7.18	.2226	1.60	10.2	.3137
.81	7.22	.2238	1.65	10.3	.3204
.82	7.26	.2251	1.70	10.5	.3238

CORRESPONDENT HEIGHTS, VELOCITIES, AND TIMES OF FALLING
BODIES—(Continued.)

$H = \frac{v^2}{2g}$	$v = \sqrt{2gH}$	$t = \frac{\sqrt{2H}}{g}$	$H = \frac{v^2}{2g}$	$v = \sqrt{2gH}$	$t = \frac{\sqrt{2H}}{g}$
Head in feet.	Velocity in feet per second.	Time in seconds.	Head in feet.	Velocity in feet per second.	Time in seconds.
1.75	10.6	.3302	8.4	23.3	.7210
1.80	10.8	.3333	8.6	23.5	.7319
1.85	10.9	.3394	8.8	23.8	.7395
1.90	11.1	.3423	9.	24.1	.7469
1.95	11.2	.3482	9.2	24.3	.7572
2.	11.4	.3509	9.4	24.6	.7642
2.1	11.7	.3590	9.6	24.8	.7742
2.2	11.9	.3697	9.8	25.1	.7809
2.3	12.2	.3770	10.	25.4	.7866
2.4	12.4	.3871	10.5	26.	.8077
2.5	12.6	.3968	11.	26.6	.8277
2.6	12.9	.4031	11.5	27.2	.8456
2.7	13.2	.4091	12.	27.8	.8633
2.8	13.4	.4179	12.5	28.4	.8803
2.9	13.7	.4234	13.	28.9	.8997
3.	13.9	.4317	13.5	29.5	.9153
3.1	14.1	.4397	14.	30.	.9333
3.2	14.3	.4476	14.5	30.5	.9508
3.3	14.5	.4552	15.	31.1	.9646
3.4	14.8	.4595	15.5	31.6	.9810
3.5	15.	.4667	16.	32.1	.9969
3.6	15.2	.4737	16.5	32.6	1.0123
3.7	15.4	.4805	17.	33.1	1.0272
3.8	15.6	.4872	17.5	33.6	1.0417
3.9	15.8	.4937	18.	34.	1.0588
4.	16.	.5000	18.5	34.5	1.0725
4.2	16.4	.5122	19.	35.	1.0857
4.4	16.8	.5238	19.5	35.4	1.1017
4.6	17.2	.5343	20.	35.9	1.1142
4.8	17.6	.5454	20.5	36.3	1.1295
5.	17.9	.5587	21.	36.8	1.1413
5.2	18.3	.5683	21.5	37.2	1.1559
5.4	18.7	.5775	22.	37.6	1.1702
5.6	19.	.5895	22.5	38.1	1.1811
5.8	19.3	.6010	23.	38.5	1.1948
6.	19.7	.6091	23.5	38.9	1.2082
6.2	20.	.6200	24.	39.3	1.2214
6.4	20.3	.6305	24.5	39.7	1.2343
6.6	20.6	.6408	25	40.1	1.2469
6.8	20.9	.6507	26	40.9	1.2714
7.	21.2	.6604	27	41.7	1.2950
7.2	21.5	.6698	28	42.5	1.3176
7.4	21.8	.6789	29	43.2	1.3426
7.6	22.1	.6878	30	43.9	1.3667
7.8	22.4	.6964	31	44.7	1.3870
8.	22.7	.7048	32	45.4	1.4097
8.2	23.	.7130	33	46.1	1.4317

CORRESPONDENT HEIGHTS, VELOCITIES, AND TIMES OF FALLING
BODIES—(Continued.)

$H = \frac{v^2}{2g}$	$v = \sqrt{2gH}$	$t = \sqrt{\frac{2H}{g}}$	$H = \frac{v^2}{2g}$	$v = \sqrt{2gH}$	$t = \sqrt{\frac{2H}{g}}$
Head in feet.	Velocity in feet per second.	Time in seconds.	Head in feet.	Velocity in feet per second.	Time in seconds.
34	46.7	1.4561	77	70.4	2.1874
35	47.4	1.4768	78	70.9	2.2003
36	48.1	1.4968	79	71.3	2.2160
37	48.8	1.5164	80	71.8	2.2284
38	49.5	1.5354	81	72.2	2.2438
39	50.1	1.5569	82	72.6	2.2590
40	50.7	1.5779	83	73.1	2.2709
41	51.3	1.5984	84	73.5	2.2857
42	52.	1.6154	85	74.0	2.2973
43	52.6	1.6350	86	74.4	2.3118
44	53.2	1.6541	87	74.8	2.3262
45	53.8	1.6729	88	75.3	2.3373
46	54.4	1.6912	89	75.7	2.3514
47	55.	1.7090	90	76.1	2.3653
48	55.6	1.7266	91	76.5	2.3791
49	56.2	1.7438	92	76.9	2.3927
50	56.7	1.7637	93	77.4	2.4031
51	57.3	1.7801	94	77.8	2.4165
52	57.8	1.7993	95	78.2	2.4297
53	58.4	1.8151	96	78.6	2.4427
54	59.	1.8305	97	79.0	2.4557
55	59.5	1.8487	98	79.4	2.4685
56	60.	1.8667	99	79.8	2.4812
57	60.6	1.8812	100	80.3	2.4907
58	61.1	1.8985	125	89.7	2.7871
59	61.6	1.9156	150	98.3	3.0519
60	62.1	1.9324	175	106	3.3019
61	62.7	1.9458	200	114	3.5088
62	63.2	1.9620	225	120	3.7500
63	63.7	1.9780	250	126	3.9683
64	64.2	1.9938	275	133	4.1353
65	64.7	2.0093	300	139	4.3165
66	65.2	2.0245	350	150	4.6667
67	65.7	2.0396	400	160	5.0000
68	66.2	2.0544	450	170	5.2941
69	66.7	2.0690	500	179	5.5866
70	67.1	2.0864	550	188	5.8511
71	67.6	2.1006	600	197	6.0914
72	68.1	2.1145	700	212	6.6038
73	68.5	2.1313	800	227	7.0485
74	69.	2.1449	900	241	7.4689
75	69.5	2.1583	1000	254	7.8740
76	69.9	2.1745			

CHAPTER XI.

FLOW OF WATER THROUGH ORIFICES.

200. Motion of the Individual Particles.—If an aperture is made in the bottom or side of a tank, filled with water, the particles of water will move from all portions of the body toward the opening, and each particle flowing out will arrive at the aperture with a velocity, V , dependent upon the pressure or head of water upon it, and, as we shall see hereafter, upon its initial position.

201. Theoretical Volume of Efflux.—If we assume the fluid veins to pass out through the orifice parallel with each other, and with a velocity due to the head upon each, and the section of the jet to be equal to the area, S , of the orifice, then the theoretical volume, or quantity, Q , of discharge will equal $S \times V = S\sqrt{2gH}$; H being the head upon the centre of the orifice, and g the acceleration of gravity per second = 32.2 feet. We have then for the theoretical volume

$$Q = S \sqrt{2gH}.$$

202. Converging Path of Particles.—The particles are observed to approach the orifice, not in parallel veins, but by curved converging paths, and if the partition is "*thin*," the convergence is continued slightly beyond the partition, a distance dependent upon the velocity of the particles.

203. Classes of Orifices.—If the top of the orifice is beneath the surface of the water, the orifice is termed a submerged orifice, and if the surface of the water is below the

top of the orifice, the notch is termed a “weir.” We are now to consider *submerged* orifices.

204. Form of Submerged Orifice-jet.—In Fig. 20 is shown a submerged circular orifice in thin partition.

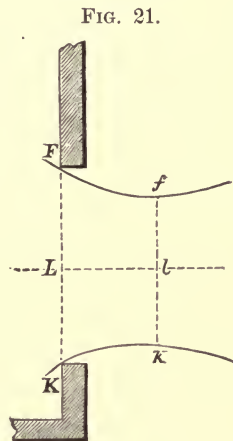
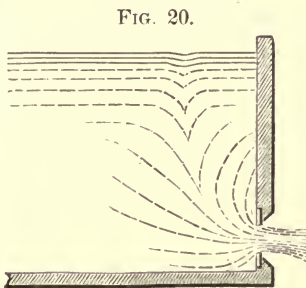

In Fig. 21 are delineated more clearly the proportions of the issuing jet at the contracted vein, or *venâ contractâ*, as it was termed by Newton. The form of the contracted vein has been the subject of numerous measurements, and as the result of late experiments writers now usually assign to the three dimensions FK , fk , and Ll , the ratios 1.00, 0.7854, 0.498, as mean proportions of circular jets not exceeding one-half foot diameter.

205. Ratio of Minimum Section of Jet.—The particles of the jet that arrive at the centre of the orifice have a direction parallel with the axis of the orifice. The particles that arrive near the perimeter have converging directions, and since they have individually both weight and velocity, they have also individual force or momentum in their directions. This force must be deflected into a new direction, and as it can be most easily deflected through a curved

path, the curve is continued until the particles have parallelism. The point where the direction of the particles is parallel is at a distance from the inside of a small square-edged orifice, equal to about one-half the diameter of the orifice, and the diameter of the jet at that point is equal to about 0.7854 of the diameter of the orifice. The cross-section of a circular jet at the same point has therefore a mean ratio to the area of the orifice as $(0.7854)^2$ to $(1.00)^2$, or as 0.617 to 1.00.

206. Volume of Efflux.—If the velocity due to the head upon the center of the orifice is the mean velocity of all the particles of the jet, then we have for the volume of discharge,

$$Q = 0.617 S \times V, \text{ or } Q = 0.617 S \sqrt{2gH}. \quad (2)$$

The real volume, Q , of the jet, and its ratios of velocity and of contraction, have been the subjects of many observations, and have engaged the attention of the ablest experimentalists and hydraulicians, from time to time, during many years.

207. Coefficient of Efflux.—In every jet flowing through a thin orifice there is a reduction of the diameter of the jet immediately after it passes the orifice. Some fractional value of the area S , or the velocity V , or the theoretical volume Q , must therefore be taken—that is, they must be multiplied by some fraction coefficient to compensate for the reduction of the theoretical volume of the jet. This fractional coefficient is termed the *coefficient of discharge*. Place the symbol c to represent this coefficient, and the formula for volume of discharge becomes

$$Q = cS \sqrt{2gH}. \quad (3)$$

208. Maximum Velocity of the Jet.—The point where the mean velocity of the particles is greatest is in the

least section of the jet, and here only can it approximate to $\sqrt{2gH}$. The mean velocity will be less at the entrance to the orifice, and also after passing the contraction, than in the contraction. When speaking of the velocity of the particles or of the jet hereafter, in connection with orifices, the maximum velocity—that is, the velocity in the contraction—is referred to, unless otherwise specially stated.

209. Factors of the Coefficient of Efflux.—If the edges of the orifice are square, the circumferential particles of the jet receive some reaction from them; therefore only the axial particles can have a velocity equal to $\sqrt{2gH}$, and the *mean* velocity is a small fraction less.

In such case the general coefficient of discharge (*c*) will be the product of two factors, one representing the reduction of velocity, and the other the reduction of the sectional area of the jet.

We shall have occasion to investigate these factors after we have determined the value of the general coefficient.

210. Practical Use of a Coefficient.—The usefulness of a *coefficient*, when it is to be applied to new computations, depends upon its accord with practical results.

All new and successful hydraulic constructions of original design must have their proportions based upon computations previously made. Those computations must be founded upon hydrodynamic formulæ in which the coefficient performs a most important office. In fact the skillful application of formulæ to hydraulic designs depends upon the skillful adaptation of the one or more coefficients therein.

The coefficient product adopted must harmonize with results before obtained, practically or experimentally, and the parallelism of all the conditions of the old or experimental structure and the new design cannot be too closely

scrutinized when an experimental result is to control a new design for practical execution.

211. Experimental Coefficients.—A few experimental results are here submitted as worthy of careful study.

From Michelotti.—The following table of experiments with square and circular orifices, by Michelotti, we find quoted by Neville.* They refer to a very carefully made set of experiments, with an extensive apparatus specially prepared, near Turin, where the apparatus was supplied with the waters of the Doire by a canal.

The table is given by Neville in French measures, but they are given here as we have reduced them to English measures.

TABLE No. 41.

COEFFICIENTS FROM MICHELOTTI'S EXPERIMENTS.

DESCRIPTION, AND SIZE OF ORIFICE, IN FEET.	Depth upon the center of the orifice in feet.	Quantity discharged in cubic feet.	Time of discharge in seconds.	Resulting coefficients of discharge.
Square orifice, 3.197'' × 3.197'' = .071 square foot section....	7.05	561.240	600	.619
	7.30	685.762	720	.619
	12.43	625.652	510	.610
	12.59	741.036	600	.611
	23.13	502.931	300	.612
Square orifice, 2.13156'' × 2.13156'' = .0315 square foot section..	23.14	604.362	360	.613
	7.06	399.266	900	.660
	12.17	512.650	900	.645
Sq. orifice, 1.06578'' × 1.06578'' = .0079 square foot section..	22.86	466.500	600	.643
	7.20	191.940	1800	.628
	12.59	198.300	1440	.612
Circular orifice, 3.197'' diameter = .05577 square foot section..	22.90	681.500	3600	.625
	7.13	657.130	900	.611
	12.31	691.200	720	.610
Circular orifice, 2.13156'' diam. = 0.2477 square foot section..	23.03	631.090	480	.612
	7.23	591.610	1800	.616
	11.71	713.700	1680	.605
Circular orifice, 1.06578'' diam. = .0062 square foot section...	23.44	696.700	1200	.605
	7.33	299.449	3600	.619
	12.51	392.370	3600	.620
Circular orifice, 6.378'' diameter.	23.45	538.158	3600	.621
	6.92619
	12.01619

* Hydraulic Tables, by John Neville, C. E. ; M.R.I.A., London, 1853.

From Abbe Bossut.—From experiments made by the Abbé Bossut we have the following results, as reduced to English measures :

TABLE No. 42.

COEFFICIENTS FROM BOSSUT'S EXPERIMENTS.

DESCRIPTION, POSITION, AND SIZE OF ORIFICE, IN INCHES.	Depth of the centre of the orifice, in feet.	Discharge, in cubic feet per minute.	Resulting coefficient.
Lateral and circular, .53289" diameter.....	9.59	1.096	.613
" " " 1.06578" "	9.59	4.344	.617
" " " .53289" "	4.273	.723	.616
" " " 1.06578" "	4.273	1.952	.619
" " " 1.06578" "0529	.341	.649
Horizontal and circular, .53289" diameter.....	12.54	1.255	.614
" " " 1.06578" "	12.54	5.040	.617
" " " 2.13156" "	12.54	20.201	.618
Horizontal and square, 1.06578" × 1.06578"....	12.54	6.417	.617
" " " 2.13156" × 2.13156"....	12.54	25.717	.618
Horizontal and rectangular, 1.06578" × .26644"'. .	12.54	1.593	.613

From Rennie.—We have also, from experiments of Rennie with circular and square orifices, under low heads, the following :

TABLE No. 43.

COEFFICIENTS FOR CIRCULAR ORIFICES.

Heads at the centre of the orifice, in feet.	$\frac{1}{2}$ inch diameter.	$\frac{3}{4}$ inch diameter.	$\frac{1}{2}$ inch diameter.	1 inch diameter.	Mean Values.
1	.671	.634	.644	.633	.645
2	.653	.621	.652	.619	.636
3	.660	.636	.632	.628	.639
4	.662	.626	.614	.584	.621
Means.....	.661	.629	.635	.616	.635

COEFFICIENTS FOR RECTANGULAR ORIFICES.

Heads at the centre of gravity, in feet.	1 inch x 1 inch.	2 inches wide x $\frac{1}{2}$ inch high.	$1\frac{1}{2}$ inches wide x $\frac{2}{3}$ inch high.	Equilateral triangle of 1 square inch, base down.	Same triangle, with base up.
1	.617	.617	.663	—	.596
2	.635	.635	.668	—	.577
3	.606	.606	.606	—	.572
4	.593	.593	.593	.593	.593
Means.....	.613	.613	.632	.593	.585

From Castel.—In 1836, M. Castel, the accomplished hydraulic engineer of the city of Toulouse, made with care certain experiments by request of D’Aubuisson, to determine the volume of water discharged through apertures in thin partitions.

He placed a dam of thin copper plate in a sluice which was 2.428 feet broad, and in the plate opened three rectangular apertures, each 3.94 inches wide and 2.36 inches high. The distance between the orifices was 3.15 inches. The flow took place under constant heads of 4.213 inches above the centres of gravity of the orifices, with contractions as follows :

One orifice open.	{	Coefficient for the middle.....	.6198
		“ “ right.....	.6192
		“ “ left.....	.6194
Two orifices open.	{	Coefficient for the two outsides... ..	.6205
		“ “ middle and right.....	.6205
		“ “ “ “ left.....	.6207
Three orifices open, coefficient for all.....		.6230	

Subsequently, he experimented with two orifices, 1.97 inches wide and 1.18 inches high, with results as follows :

Head.	No. of orifices open.	Coefficient.
3.379.....	{ 1	.621
	{ 2	.622
6.693.....	{ 1	.619
	{ 2	.621

When more than one aperture was open in these experiments of Castel, the volume of water discharged induced considerable velocity in each of the supplying sluices. This actually increased the *effective* head. Its effect is here recorded in the coefficient instead of in the head, consequently an increased coefficient is given.

In such cases the real head is the observed head increased by the head due to the velocity of approach =

$$H + \frac{V^2}{64.4}.$$

From Lespinasse.—From among experiments on a larger scale, the following by Lespinasse, with a sluice of the canal of Languedoc, are of interest :

TABLE NO. 44.
COEFFICIENTS OBTAINED BY LESPINASSE.

OPENINGS.			HEAD ON THE CENTRE.	DISCHARGE IN ONE SECOND.	COEFFICIENT.
Breadth.	Height.	Area.			
<i>Feet.</i> 4.265	<i>Feet.</i> 1.805	<i>Sq. feet.</i> 7.745	<i>Feet.</i> 14.554	<i>Cubic feet.</i> 145.292	.613
"	1.640	6.992	6.631	92.635	.641
"	1.640	6.992	6.247	88.221	.629
"	1.509	6.466	12.878	138.937	.641
"	1.575	6.723	13.586	128.764	.647
"	1.575	6.723	6.394	83.948	.616
"	1.575	6.723	6.217	79.857	.594
"	1.575	6.717	6.480	85.219	.621

From Gen. Ellis.—Gen. Theo. G. Ellis has reported in a paper* presented to the American Society of Civil Engineers, the results of some experiments very carefully conducted by him at the Holyoke testing flume in the summer of 1874.

* Hydraulic Experiments with Large Apertures. Jour. Am. Soc. Civ. Eng., 1876, Vol. V, p. 19.

The coefficients for the minimum, mean, and maximum velocities are given to indicate generally the range, and the results obtained by Gen. Ellis.

The volume of water discharged was determined by weir measurement, and computed by Mr. James B. Francis' formula.

The edges of the orifices were plated with iron about one-half inch thick, jointed square.

VERTICAL APERTURE, 2 ft. \times 2 ft.

Minimum head, 2.061 feet.	Coefficient, .60871	} Centre of aperture, 1.90 feet above top of weir. Temp. of water, 73° Fah.
Mean " 3.037 "	" .59676	
Maximum " 3.538 "	" .60325	

VERTICAL APERTURE, 2 ft. horizontal \times 1 ft. vertical.

Minimum head, 1.7962 feet.	Coefficient, .59748	} Centre of aperture, 2.40 feet above top of weir. Temp. of water, 76° Fah.
Mean " 5.7000 "	" .59672	
Maximum " 11.3150 "	" .60572	

VERTICAL APERTURE, 2 feet horizontal \times .5 feet vertical.

Minimum head, 1.4220 feet.	Coefficient, .61165	} Centre of aperture, 2.15 feet above top of weir. Temp. of water, 76° Fah.
Mean " 8.5395 "	" .60686	
Maximum " 16.9657 "	" .60003	

VERTICAL APERTURE, 1 ft. \times 1 ft.

Minimum head, 1.4796 feet.	Coefficient, .58230	}
Mean " 9.8038 "	" .59612	
Maximum " 17.5647 "	" .59687	

HORIZONTAL APERTURE, 1 ft. \times 1 ft. AND SLIGHTLY SUBMERGED
ISSUE.

Minimum head, 2.3234 feet.	Coefficient, .59871	} Top surface of orifice .441 feet above crest of weir.
Mean " 8.0926 "	" .60601	
Maximum " 18.4746 "	" .60517	

HORIZONTAL APERTURE (IN PLANK) WITH CURVED ENTRANCE AND
SLIGHTLY SUBMERGED ISSUE.

Minimum head, 3.0416 feet.	Coefficient, .95118	} Issue about level with crest of weir.
Mean " 10.5398 "	" .94246	
Maximum " 18.2180 "	" .94364	

The range, and results generally, of Gen. Ellis' experiments with circular vertical orifices, are indicated by the following extracts from his extended tables:

TABLE No. 43.

COEFFICIENTS FOR CIRCULAR ORIFICES, OBTAINED BY GEN. ELLIS.

DIAMETERS.	HEAD.	COEFFICIENTS.
2 feet.	1.7677 feet.	.58829
" "	5.8269 "	.60915
" "	9.6381 "	.61530
1 foot.	1.1470 feet.	.57373
" "	10.8819 "	.59431
" "	17.7400 "	.59994
.5 foot.	2.1516 feet.	.60025
" "	9.0600 "	.60191
" "	17.2650 "	.59626

212. Coefficients Diagrammed.—The coefficients, as developed by the several experimenters, seem at first glance to be very fitful, and without doubt the apparatus used varied in character as much as the results obtained

To arrange all the series of coefficients that appeared to have been obtained by a reliable method, in a systematic manner, we have plotted all to a scale, taking the heads for abscisses and the coefficients for ordinates. The curves thus developed were brought into their proper relations, side by side, or interlacing each other.

Then we were able to plot in the midst of those curves the general curves due to each class of orifice under the several heads, and those apparently due to the law governing the flow of water through submerged orifices.

From these curves we have prepared tables of coefficients for various rectangular orifices, with greatest dimension,

both horizontal and vertical, with ratios of sides varying from 0.125 to 1, to 4 to 1, and for heads varying from 0.2 feet to 50 feet.

All of the curves increase from that for very low heads rapidly as the head increases, until a maxima is reached, and then to decrease gradually until a minima is reached, and then again to increase very gradually, the head increasing all the time. This increase, and decrease, and increase again of the coefficients, arranges them, when thus plotted, into two curves of opposite flexure, and with all the curves tending to pass through one intermediate point.

213. Effect of Varying the Head, or the Proportions of the Orifice.—The effect of increasing or decreasing the head upon a given orifice is clearly shown by the several columns of coefficients in Tables 46 and 47.

The effect of increasing or decreasing the ratio of the base to the altitude of an orifice will be manifest by tracing the lines of coefficients horizontally through the two tables, for any given head.

These effects should be duly considered when a coefficient is to be selected from the table for a special application.

The coefficients apply strictly to orifices with sharp, square edges, and with full contraction upon all sides. The heads refer to the full head of the water surface, and not to the depressed surface over or just in front of an orifice when the head is small.

A very slight rounding of the edge would increase the coefficient materially, as would the suppression of the contraction upon a portion of its border by interference with the curve of approach of the particles.

TABLE No. 46.

COEFFICIENTS FOR RECTANGULAR ORIFICES.

In thin vertical partition, with greatest dimension *vertical*.

BREADTH AND HEIGHT OF ORIFICE.

Head upon centre of orifice.	4 feet high, 1 foot wide.	2 feet high, 1 foot wide.	1½ feet high, 1 foot wide.	1 foot high, 1 foot wide.
<i>Feet.</i>	<i>Coefficient.</i>	<i>Coefficient.</i>	<i>Coefficient.</i>	<i>Coefficient.</i>
.65984
.75994
.86130	.6000
.96134	.6006
16135	.6010
1.256188	.6140	.6018
1.506187	.6144	.6026
1.756186	.6145	.6033
26183	.6144	.6036
2.256180	.6143	.6039
2.5	.6290	.6176	.6139	.6043
2.75	.6280	.6173	.6136	.6046
3	.6273	.6170	.6132	.6048
3.5	.6250	.6160	.6123	.6050
4	.6245	.6150	.6110	.6047
4.5	.6226	.6138	.6100	.6044
5	.6208	.6124	.6088	.6038
6	.6158	.6094	.6063	.6020
7	.6124	.6064	.6038	.6011
8	.6090	.6036	.6022	.6010
9	.6060	.6020	.6014	.6010
10	.6035	.6015	.6010	.6010
15	.6040	.6018	.6010	.6011
20	.6045	.6024	.6012	.6012
25	.6048	.6028	.6014	.6012
30	.6054	.6034	.6017	.6013
35	.6060	.6039	.6021	.6014
40	.6066	.6045	.6025	.6015
45	.6054	.6052	.6029	.6016
50	.6086	.6060	.6034	.6018

TABLE No. 47.

COEFFICIENTS FOR RECTANGULAR ORIFICES.

In thin vertical partition, with greatest dimension *horizontal*.

BREADTH AND HEIGHT OF ORIFICE.				
Head upon centre of orifice.	0.75 feet high, 1 foot wide.	0.50 feet high, 1 foot wide.	0.25 feet high, 1 foot wide.	0.125 feet high, 1 foot wide.
<i>Feet.</i>	<i>Coefficient.</i>	<i>Coefficient.</i>	<i>Coefficient.</i>	<i>Coefficient.</i>
0.26333
.36293	.6334
.46140	.6306	.6334*
.5	.6050	.6150	.6313	.6333
.6	.6063	.6156	.6317	.6332
.7	.6074	.6162	.6319	.6328
.8	.6082	.6165	.6322	.6326
.9	.6086	.6168	.6323*	.6324
1	.6090	.6172	.6320	.6320
1.25	.6095	.6173*	.6317	.6312
1.50	.6100	.6172	.6313	.6303
1.75	.6103	.6168	.6307	.6296
2	.6104*	.6166	.6302	.6291
2.25	.6103	.6163	.6293	.6286
2.50	.6102	.6157	.6282	.6278
2.75	.6101	.6155	.6274	.6273
3	.6100	.6153	.6267	.6267
3.50	.6094	.6146	.6254	.6254
4	.6085	.6136	.6236	.6236
4.50	.6074	.6125	.6222	.6222
5	.6063	.6114	.6202	.6202
6	.6044	.6087	.6154	.6154
7	.6032	.6058	.6110	.6114
8	.6022	.6033	.6073	.6087
9	.6015	.6020	.6045	.6070
10	.6010	.6010	.6030	.6060
15	.6012	.6013	.6033	.6066
20	.6014	.6018	.6036	.6074
25	.6016	.6022	.6040	.6083
30	.6018	.6027	.6044	.6092
35	.6022	.6032	.6049	.6103
40	.6026	.6037	.6055	.6114
45	.6030	.6043	.6062	.6125
50	.6035	.6050	.6070	.6140

214. Peculiarities of Efflux from an Orifice.—

In Fig. 22, containing a horizontal orifice, the horizontal line cutting *a* has an altitude above the orifice equal to 3.5 diameters, and the horizontal line cutting *e* equal to 10 diameters of the orifice. As the altitude of the water sur-

FIG. 22.

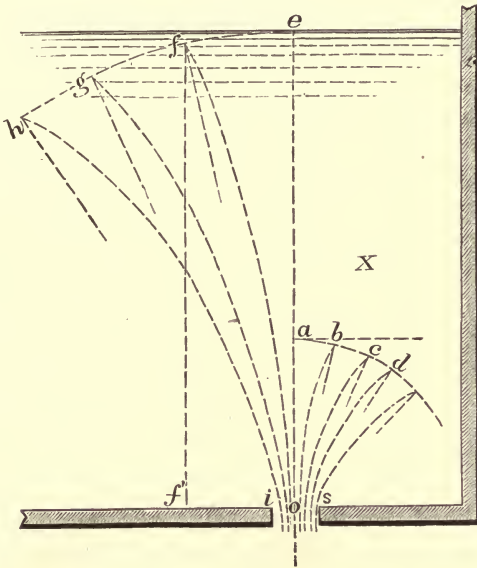

face above a square orifice increases from very low heads to the level *a*, the particles continually find new advantage or less hindrance in their tendency to flow out of the orifice, possibly by decrease of the vortex effect accompanying very low heads over orifices nearly square; afterwards the resistance increases up to the altitude *e*, possibly by more effective reaction from the inner edges of the orifice, *is*, until gravity is enabled to gather the jet well into a body and establish firmly its path. For altitudes greater than ten diameters the coefficients for square orifices remain nearly constant.

Similar effects are observed when the orifices are rectangles, other than squares, though their first change occurs at different depths.

These phenomena are not fully accounted for by experiment.

215. Mean Velocity of the Issuing Particles.—

We have heretofore assumed in our theoretic equations, that all the particles of water *b c d e f g*, Fig. 22, will arrive at the point of greatest contraction of the issuing jet, with a velocity equal to that which a solid body would have acquired by falling freely from *e* to *o*, which, according to the theorem of Toricelli, and its demonstrations frequently repeated by other eminent philosophers, would be equal to $\sqrt{2gH}$. *H* being equal to the height *e o*.

The experiments of Mariotte, Bossut, Michelotti, Poncelet, Pousseile, and others, covering a large range of areas of orifice, and of head, show that this is very nearly correct; and the velocity of issue of the axial particles has in some of the experiments appeared to slightly exceed the value of $\sqrt{2gH}$. An average of experiments gives the *mean* velocity of the particles as a whole through the minimum section as $.974 \sqrt{2gH}$.

Their dynamic effect if applied to work should have $.974 \sqrt{2gH}$ instead of $\sqrt{2gH}$ as the factor of velocity.

216. Coefficients of Velocity and Contraction.—

We have then, $.974$ for mean coefficient of *velocity*, indicating a loss of $.026$ per cent. of theoretic volume or discharge by reduction of velocity; $.637$ for mean coefficient of *contraction*, indicating a loss of 36.3 per cent. of theoretic volume by contraction; and $.62$ nearly for mean coefficient of *discharge*, including all losses, a total of about 38 per cent.

The coefficient of velocity we will designate by c_v , and the coefficient of contraction by c_c .

Then $c_p \times c_e = c =$ coefficient of discharge or volume.

217. Velocity of Particles Dependent upon their Angular Position.—Bayer assumed the hypothesis that, the velocities of the particles approaching the orifice from all sides are inversely as the squares of their distances from its centre, but this should undoubtedly be applied only to particles in some given angular position.

Gravity will not act with equal force in the direction of the orifice, upon each of the particles $e, f, g,$ and $h,$ Fig. 22, though they are all equally distant from $o,$ but more nearly in the ratios of the cosines of the angles $eo e, eof, eog,$ etc., and it is not probable that the particle h will acquire a velocity at its maximum through the contraction, quite equal to that which e will acquire. If the velocity of e is assumed equal to unity, and the mean velocity of all the particles equal to .974, then, according to the hypothesis of the angular distance, the mean velocity will be that due to particles having their cosines equal to .974, or an angular distance of $13^\circ,$ as at b and $f.$

218. Equation of Volume of Efflux from a Submerged Orifice.—Neville suggests a formula* for the discharge of water from rectangular orifices, more strictly mathematical than the above simple formulas, as follows :

$$D = c \sqrt{2gh} \times \frac{2}{3} A \left(\frac{(h + \frac{1}{2}d)^{\frac{3}{2}} - (h - \frac{1}{2}d)^{\frac{3}{2}}}{dh^{\frac{1}{2}}} \right) \quad (4)$$

when $D =$ volume of discharge,

$A =$ area of orifice,

$h =$ head upon the centre of the orifice,

$d =$ depth of the orifice, or distance between its
bottom and top,

$c =$ coefficient of discharge.

* Third Edition of Hydraulic Tables, page 48. London, 1875. Also *vide* equation 3, page 283, *ante.*

This formula can be advantageously applied when the orifice is large and but slightly submerged, as is frequently the case with sluice gates controlling the flow of water from storage reservoirs or canals into flumes leading to water-wheels, or with head-gates of races or canals.

Good judgment must, however, be exercised in each case in the selection of the coefficient of velocity (c_v) and the coefficient of contraction (c_c), the factors of c , especially the coefficient of contraction (§ 216), which is usually much the most influential of the two.

219. Effect of Outline of Symmetrical Orifices upon Efflux.—According to the various series of experiments, the coefficient for a circular orifice under any given head is substantially the same as for a square orifice under the same head, and it is probable that the coefficients for elliptical orifices is substantially the same as that for their circumscribing rectangles.

220. Variable Value of Coefficients.—The coefficients obtained by careful experiment and recorded above, as also tables of coefficients, indicate unmistakably that the value of c in the equation

$$Q = cS \sqrt{2gH}$$

is a variable quantity, and that a general *mean* coefficient cannot be used universally when close approximate results are desired, but that, for a particular case, reference should always be made to a coefficient obtained under conditions similar to that of the case in question.

221. Assumed Mean Volume of Efflux.—In ordinary approximate calculations, and in general discussions of formulas for square and circular orifices, whether the jet issues horizontally or vertically, it is customary to assume 0.62 as the ratio of the actual to the theoretical volume of

discharge. This makes the equation for ordinary calculations :

$$Q = .62S\sqrt{2gH}, \text{ or } Q = .62SV. \quad (5)$$

The expression for effect of acceleration of gravity ($2g$) being a constant quantity, may be combined with the coefficient, when $(.62\sqrt{2g} = 4.9725)$ we have the equation

$$Q = 4.9725S\sqrt{H}, \text{ or approximately, } Q = 5.S\sqrt{H}. \quad (6)$$

Q being the discharge in cubic feet in one second, it will be multiplied by 60 to determine the discharge in one minute, and by 3600 to determine the discharge in one hour.

222. Circular, and other Forms of Jets.—A circular aperture, with full contraction, gives a jet always circular in section, until it is broken up into globules by the effects of the varying velocities of its molecules and the resistance of the air. Through the *venâ contractâ* its form is that of a truncated conoid.

Polygonal and rectangular orifices give jets that continually change their sectional forms as they advance.

Fig. 22a, from D'Aubuisson's Treatise on Hydraulics, illustrates the transformations of forms of a jet from a square orifice, $ACEG$. The jet is square at the entrance to the aperture, assumes the form $bcdefgha$ a short distance in front of it, and the form $a'c'e'g'$ a short distance further on, and continues to assume new forms until its solidity is destroyed. Symmetrical orifices, without re-entrant angles, give symmetrical jets that assume symmetrical, varying sections.

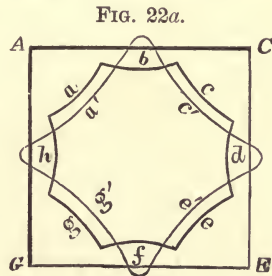
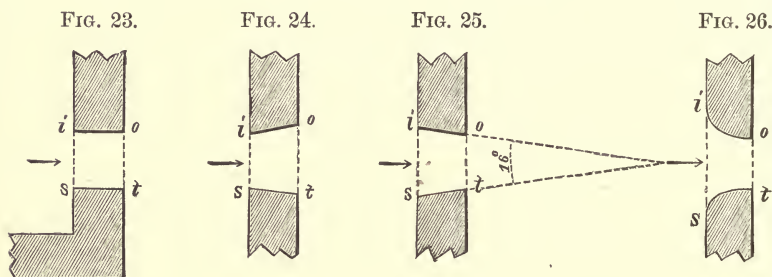

FIG. 22a.

Star-shaped and irregular orifices, upon close observa-

tion, are found to give very complex forms of jets. Their coefficients of efflux have not been fully developed by experiment.

223. Cylindrical and Divergent Orifices.—In Fig. 23 and Fig. 24 showing cylindrical and divergent orifices, if the diameters, is , of the orifices, are greater than the



thickness of the partitions, the coefficients of discharge will remain the same as in thin plate. In such cases the jets will pass through the orifices without touching them, except at the edges, is . Such orifices are also termed thin.

224. Converging Orifices.—In Fig. 25 and Fig. 26, showing converging orifices in thin partitions, if the diameters, is , are taken, the coefficients will be reduced to .58, or a little less; but if the diameters, ot , are taken, the coefficients will be increased nearly to .90, and will be greater, for any given velocity, in proportion as the forms of the orifices approach to the form of the perfect *venâ contractâ*, for that velocity.

When the converging sides of the orifice in Fig. 25, prolonged, include an angle of 16° , the coefficient should be about .93, and when in Fig. 26 the sides of the orifice are in the form of the *venâ contractâ*, the coefficient should be about .95..



PUMPING STATION, MANCHESTER,

CHAPTER XII.

FLOW OF WATER THROUGH SHORT TUBES.

225. An Ajutage.—If a cylindrical orifice is in a partition whose thickness is equal to two-and-one-half or three times the diameter of the orifice ; or if the orifice is a tube of length equal to from two and one-half to three interior diameters, then the orifice is termed a *short tube*, or *ajutage*. The sides of short tubes may be *parallel*, *divergent*, or *convergent*.

226. Increase of Coefficient.—There is an influence affecting the flow of water through short cylindrical tubes, Fig. 28, sufficient to increase the coefficient materially, that does not appear when the flow is through thin partition. The contraction of the jet still occurs as in the flow through thin partition, but after the direction of the particles has become parallel in the *venâ contractâ*, a force acting from the axis of the jet outward, together with the reaction from the exterior air, begins to dilate the section of the jet and to fill the tube again. The tube is in consequence again filled at a distance, depending upon the ratio of the velocity to the diameter, of about two and one-half diameters from the inner edge of the orifice. The axial particles of the jet, not receiving so great a proportion of the reaction from the edges of the orifice as the exterior particles, obtain a greater velocity. A portion of their force is transmitted to their surrounding films through divergent lines, and the velocity of the exterior particles within the tube is augmented, and the section of the jet is also augmented, until its circumfer-

ence touches the tube. At the same time, the transmission of force from the axis toward the circumference tends to equalize the velocity of the particles throughout the section, and to materially reduce their mean velocity, and consequently the coefficient of velocity, c_v .

227. Ajutage Vacuum and its Effect.—Immediately upon the issue of the jet, beyond the contraction, the velocity of the particles tends to impel forward the imprisoned air, and as soon as the tube fills to cause a vacuum* about the contraction. The full force of gravity is here acting upon the jet in the form of velocity; the jet is therefore without pressure in a transverse direction.

As soon as the exterior of the jet is relieved from the pressure of the atmosphere about the contraction, its particles are deflected to parallelism with less force and in a shorter distance from the entrance to the aperture, and the contraction is consequently lessened; also the pressure of the atmosphere upon the reservoir surface tends to augment the velocity of entry of the particles into the aperture toward the vacuum, and atmospheric pressure equally resists the issue of the jet, the combined effect resulting in the expansion of the jet.

228. Increased Volume of Efflux.—If the cylindrical tube terminates at the point where the moving particles reach the circumference and fill the tube, and before the *reaction from the roughness of the interior of the tube* has begun sensibly to counteract the accelerating force of gravity, the capacity of discharge is then found to be increased about twenty-five per cent., and the mean coefficient becomes .815 approximately, or if the tube projects

* If the inside of a smooth divergent tube is greased, so as to repel the particles of water and prevent contact, the vacuum cannot take place.

into the reservoir, .72, instead of .62, as in the orifice in thin plate. We have now for the volume of water discharged, in cubic feet per second,

$$Q = .815 S \sqrt{2gH}, \text{ or } Q = .815 SV, \text{ or } Q = 6.54 S \sqrt{H}. \quad (1)$$

If the section of the tube is expressed in terms of the diameter, in feet or fractional parts of feet, then since $S = .7854d^2$, the equation will become

$$Q = 6.54 (.7854d^2) \sqrt{H} = 5.137d^2 \sqrt{H}. \quad (2)$$

229. Imperfect Vacuum.—If the tube is of less length than above indicated, so that the vacuum is not perfect, the conditions of flow and the coefficient will be similar to that through thin plate; and if the tube is lengthened, the flow will be reduced by reaction from the interior of the tube, in which case the tube will be termed a pipe.

FIG. 28.

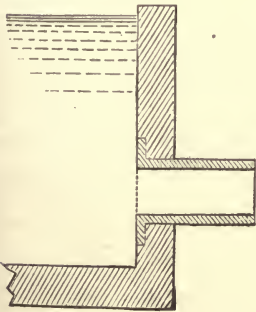

FIG. 29.

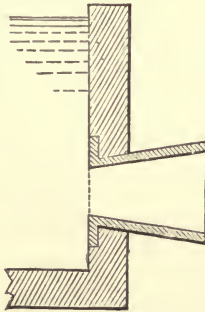
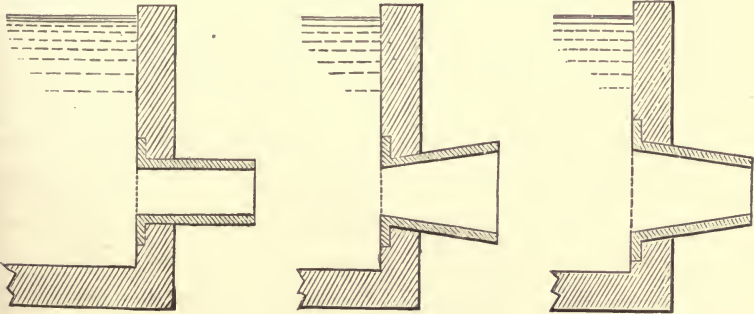

FIG. 30.



230. Divergent Tube.—When a *short divergent tube*, Fig. 29, is attached by its smaller base to the inside of a plane partition, the phenomena of discharge will be similar to that through an orifice in thin plate, unless a vacuum shall be established about its contraction, as in the case of

short cylindrical tubes. This can only occur when the divergence is slight, or the velocity great.

For ordinary cases, the *mean* coefficient of discharge through square-edged divergent tubes may be taken as .62, but it is subject to considerable variation in tubes of small divergence, as the divergences, the ratio of length to diameter, and the velocity of flow or head varies.

When a vacuum takes place in a divergent tube, the discharge exceeds that from a cylindrical tube with diameter equal to the smaller diameter of the divergent tube, and the coefficient of volume may then even become greater than unity.

231. Convergent Tube.—When a *short, convergent tube*, Fig. 30, is attached by its larger base to the inside of a plane partition, and its coefficient of flow with a perfect vacuum is determined for its diameter of entrance, as above in the cases of thin plate, cylindrical and divergent tubes, then the coefficient of volume will be found to decrease as the angle of convergence increases.

Contraction will take place as in thin plate, until the angle of convergence, that is, the included angle between the sides produced, exceeds 13° , and a vacuum will also be produced; but the exterior of the jet will reach the inner circumference and fill the tube at a shorter distance from the point of least contraction, as the angle increases, and the augmenting effect of the vacuum will be reduced.

232. Additional Contraction.—There is always an additional contraction just after the exit of the jet from convergent tubes.

The coefficient of discharge will remain in excess of the coefficient for thin plate until the second contraction equals that in thin plate, after which the coefficient will be less than for thin plate.

233. Coefficients of Convergent Tubes.—In the following table are given the coefficients of *discharge* for the larger and the smaller diameters, also of the *velocity*, for several angles of convergence. The table is based upon careful experiments by Castel. The length of the tube was 2.6 diameters, and the smaller diameter and length of tube remained constant.

TABLE No. 48.

CASTEL'S EXPERIMENTS WITH CONVERGENT TUBES.

Smallest diameter = .05085 feet.

Angle of convergence.	Larger diameter.	Smaller diameter.	Velocity.
	<i>Coefficient.</i>	<i>Coefficient.</i>	<i>Coefficient.</i>
0° 0'	0.829	0.829	0.830
1° 36'	.809	.866	.866
3° 10'	.786	.895	.894
4° 10'	.771	.912	.910
5° 26'	.747	.924	.920
7° 52'	.691	.929	.931
8° 58'	.671	.934	.942
10° 20'	.647	.938	.950
12° 4'	.611	.942	.955
13° 24'	.597	.946	.962
14° 28'	.577	.941	.966
16° 36'	.545	.938	.971
19° 28'	.501	.924	.970
21° 0'	.480	.918	.971
23° 0'	.457	.913	.974
29° 58'	.390	.896	.975
40° 20'	.319	.869	.980
48° 50'	.276	.847	.984

The coefficients for the larger diameter have been computed from the remaining data of the table for insertion here.

234. Increase and Decrease of Coefficient of Smaller Diameter.—When the coefficient of volume is

determined for the smaller diameter, or issue of a short, convergent tube, the coefficient is found to increase from that for cylindrical tubes at angle 0° to an angle of about $13^\circ 30'$, when, under the conditions upon which Castel's table was based, it has increased from .83 to .95. Afterwards, the coefficient gradually reduces, until at 180° it becomes .62, as in thin plate.

235. Coefficient of Final Velocity.—The coefficient of final velocity of issue gradually increases as the angle of convergence increases, until it rises from .83* at angle 0° to nearly unity at angle 180° ; but that, for angles less than 13° , is not the true coefficient of velocity, since it refers to the velocity of issue at the end of the tube, instead of in the contraction.

FIG. 31.

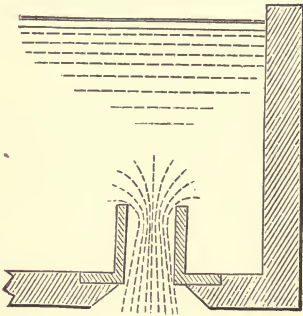

236. Inward Projecting Ajutage.—When an orifice, or the entrance of a short tube, is projected into the interior of a reservoir, as in Fig. 31, the angle of approach of the particles be-

comes greater than when the orifice is in plane partition, and the contraction becomes still more marked. Borda, when experimenting with such a tube, in which the vacuum was not perfected, found the coefficient to be .515. This coefficient may be considered as an extreme minimum.

237. Compound Tube.—When two or more of the short tubes above described are joined together endwise into one tube, as in Fig. 32, the new tube thus formed is termed a *compound tube*.

* Its mean velocity, in a cylindrical tube, after the jet has expanded beyond the contraction.

FIG. 32.

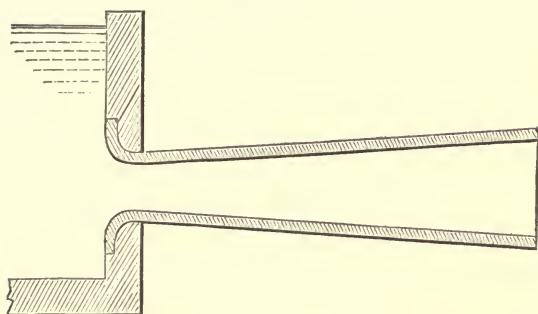

Venturi experimented with various forms and proportions of compound tubes, and observed remarkable results produced by certain of them, which apparently augmented the force of gravity.

With a tube similar to Fig. 32, but with less perfect contraction, having the included angle of the divergent tube equal to $5^{\circ} 6'$, the smallest diameter equal to 0.1109 feet, and the length equal to nine diameters, the coefficient, computed for the smallest diameter, when flowing under a constant head of 2.89 feet, was 1.46, or about 2.4 times that of an equal orifice in thin plate.

238. Coefficients of Compound Tubes.—Other forms of compound tubes, with conical diverging ajutages of different lengths and angles, gave results as follows:

TABLE No. 49.
EXPERIMENTS WITH DIVERGENT AJUTAGES.

AJUTAGE.		COEFFICIENT.	AJUTAGE.		COEFFICIENT.
Angle.	Length.		Angle.	Length.	
	<i>Feet.</i>			<i>Feet.</i>	
$3^{\circ} 30'$	0.364	0.93	$5^{\circ} 44'$.193	.82
$4^{\circ} 38'$	1.095	1.21	$10^{\circ} 16'$.865	.91
$4^{\circ} 38'$	1.508	1.21	$10^{\circ} 16'$.147	.91
$4^{\circ} 38'$	1.508	1.34	$14^{\circ} 14'$.147	.61
$5^{\circ} 44'$	0.577	1.02			

239. Experiments with Cylindrical and Compound Tubes.—The following table gives interesting results of experiments by Eytelwein with both cylindrical and compound tubes.

He first experimented with a series of cylindrical tubes of different lengths, but of equal diameters; he then placed between the cylindrical tubes and the reservoir a conical converging tube of the form of the *venâ contractâ*, and repeated the experiments; and afterwards added also to the discharge end a conical diverging tube with $5^{\circ} 6'$ angle, Fig. 33.

FIG. 33.

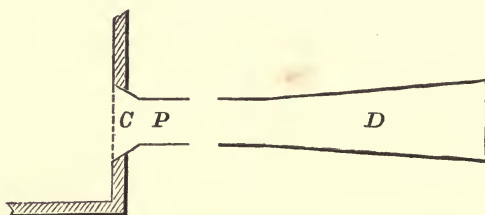

TABLE NO. 50.
EXPERIMENTS WITH COMPOUND TUBES.

Length of tube P in diameters.	Length of tube P in feet.	Coefficient for tube P.	Coefficient for tube CP.	Coefficient for tube CPD.
0.038	0.0033	0.62
1.000	.0853	.62	.967
3.000	.2559	.82	.943	1.107
12.077	1.0302	.77	.870	.978
24.156	2.0605	.73	.803	.905
36.233	3.0907	.68	.741	.836
48.272	4.1176	.63	.687	.762
60.116	5.1479	.60	.648	.702

The diameter of the tube *P* was 0.0853 feet, and the flow took place under a computed average head of 2.3642 feet. The mean head was computed by the formula,

$$H' = \left[\frac{H - h}{2(\sqrt{H} - \sqrt{h})} \right]^2 \quad (3)$$

in which H = maximum head, h = minimum head, H' = mean head.

240. Tendency to Vacuum.—The effect of the percussion of the axial particles, tending to produce a vacuum, and of the enlargement of the circumference of the jet in D , is apparent until the length reaches thirty-six diameters, and is greatest at three diameters length, though still less than with Fig. 28, because the surface of contact of the jet against the tube is greater.

241. Percussive Force of Particles.—The percussive effect of particles of water in rapid motion is illustrated by another experiment of Venturi's, with apparatus similar to Fig. 34.

A is a high tank kept filled with water, and C is a smaller tank at its base, full of water at the beginning of the experiment. P is an open-topped pipe placed in the small tank, and has holes pierced around its base, so that the water in C may enter it freely and rise to the level c . From A a small tube, e , leads a jet into P .

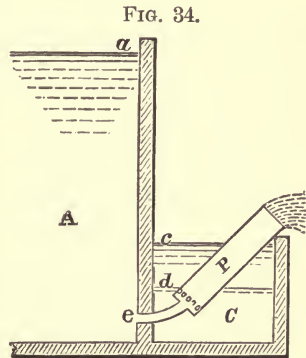

Upon the tube e being opened, the whole body of water in P is set in motion and begins to flow over its top, and the body of water in C is drawn into the pipe P through the perforations, and the surface of C will be seen to fall gradually from c to d , until air can enter through the perforations and destroy the partial vacuum in P .

For a clear conception of the effect of the particles of the jet upon the particles in P , imagine all the particles and the apparatus to be greatly magnified, so that there will appear to be a jet, e , of balls, like billiard balls, for illustration, through a mass, P , of similar balls.

242. Range of a Set of Eytelwein's Experiments.

—In the last table (No. 50), there appears the mean coefficients due to several distinct classes of apertures, viz. : 0.62 due to a tube *orifice* or orifice in thin plate, with length equal to 0.038 diameters ; 0.82 due to a *short cylindrical tube*, with length equal to 3 diameters ; 0.943 due to lessened contraction by the convergent entrance, with length equal to 3 diameters ; and 1.107 (which in more perfect form of *compound tube* we have found to be 1.46) due to convergent entrance and divergent exit, with length equal 3 diameters.

There also appears the increase of coefficient from *orifice* to *short tube*, and then the gradual reduction of all the coefficients by increase of length of tube (into *pipe*) from 3 to 60 diameters long.

These phenomena cannot fail to be of interest to students in that branch of natural philosophy which relates to hydrodynamics, and the practical hydraulician cannot afford to overlook their effects.

243. Cylindrical Tubes to be Preferred.—There is rarely occasion for the practical and honest use of the divergent tube, when its object cannot better be accomplished by a slightly increased diameter of cylindrical tube. The capability of the divergent ajutage to increase the discharge from a given diameter of orifice, was known to the ancient philosophers, and to some of the Roman citizens who had grants of water from the public conduits, and D'Aubuisson states that a Roman law prohibited their use within $52\frac{1}{2}$ feet of the entrance of the tube.



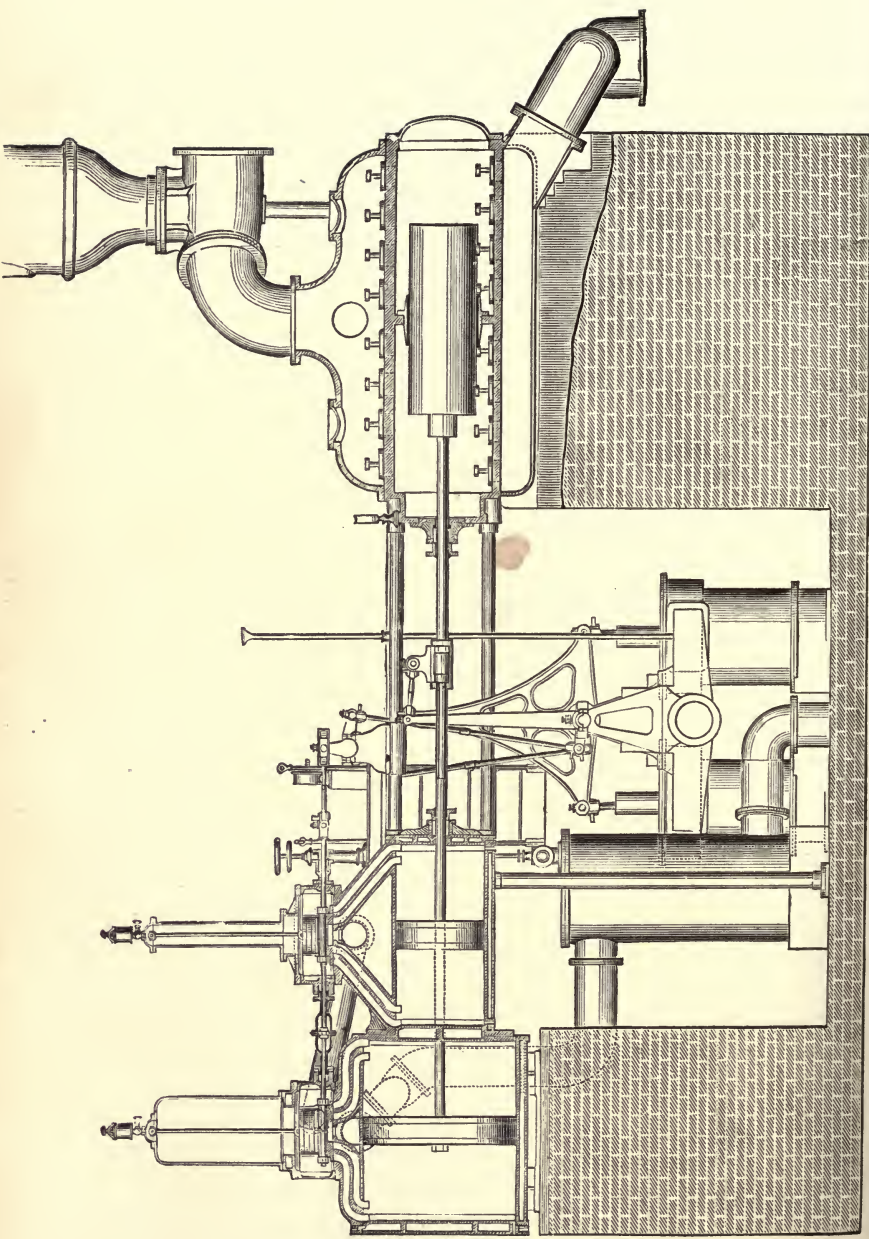

WORTHINGTON COMPOUND DUPLEX PUMPING ENGINE.

CHAPTER XIII.

FLOW OF WATER THROUGH PIPES, UNDER PRESSURE.

244. Pipe and Conduit.—A cylindrical tube intended to convey water under pressure is termed a *pipe* when its length exceeds about three times its interior diameter ; or immediately after its length has become sufficient for the completion of the vacuum about the jet flowing into it.

A long pipe constructed of masonry is termed a *conduit*, and when it is a continuous tube, or composed of sections of tubes with their axes joined in one continuous line and adapted to convey water under pressure, it is termed a *main pipe, sub-main, branch, waste, or service pipe*, according to its office.

245. Short Pipes give Greatest Discharge.—The greatest possible discharge through a cylindrical tube, due to a given head, occurs when its length is just sufficient to allow of the completion of the vacuum about the contraction of its jet at the influence, if its influent end is then sufficiently submerged to maintain the pipe full at the issue.

In the discussion of short tubes (§ 228), we have seen that their coefficient of discharge is increased from 0.62 (that for thin plate) to a mean of 0.815. There is still a loss of eighteen per cent. of the theoretical volume, due chiefly to the contraction of the vein at its entrance to the tube, from which results a loss of velocity and a loss of energy as the jet expands to fill the tube.

LOSS OF FORCE, OR EQUIVALENT HEAD, AT THE ENTRANCE TO A PIPE.

246. Theoretical Volume from Pipes.—Let *A*, Fig. 35, be a reservoir containing water one hundred feet deep = *H*, to the level of its horizontal effluent pipe, *P*. Let the pipe *P* be one foot in diameter = *d*.

Then the *theoretical* volume of discharge will equal $\sqrt{2gH} \times .7854d^2 = 63.028$ cubic feet per second ; but when the pipe is three diameters long (= 3 feet), the real discharge according to experiment will be

$$Q = .815 \sqrt{2gH} \times .7854d^2, \tag{1}$$

= 51.40 cubic feet per second.

FIG. 35.

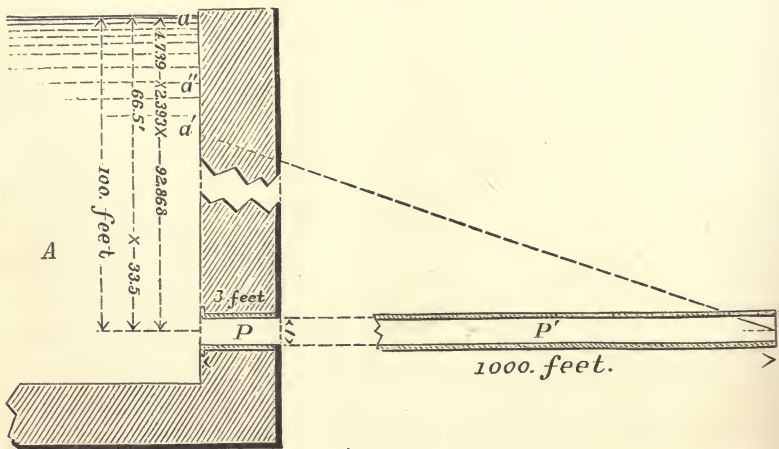

Let *V* represent the *theoretical* velocity ; then will the total head $H = \frac{V^2}{2g} = 100$ feet.

Let *v* represent the measured velocity of discharge, and *h* the head necessary to generate *v*, then $h = \frac{v^2}{2g}$.

247. Mean Efflux from Pipes.—The section of the jet, having expanded beyond the contraction issues with a diameter equal to that of the tube, and the coefficient of velocity, c_v , is consequently equal to the coefficient of discharge, c , which is, at a mean, .815 and the theoretical velocity $V = \frac{v}{c_v} = \frac{v}{.815} = 80.25$ feet per second.

248. Subdivision of the Head.—The total head H , acting upon a short cylindrical tube, consists of two portions, one of which generates $v = .815 V = 65.4$ feet per second. The other portion, capable of generating $\frac{v}{.815} - v = 14.85$ feet per second, acts in the form of pressure to overcome the resistance of entry of the jet into the tube. Let h' represent this force.

The head due to v is $h = \frac{v^2}{2g}$, = 66.5 feet in the above assumed case.

The head due to $\frac{v}{.815} - v$ is $h' = \left(\frac{v^2}{.815^2 \times 2g} - \frac{v^2}{2g} \right) = \left(\frac{1}{c_v^2} - 1 \right) \frac{v^2}{2g} = 33.5$ feet.

The ratio of h' to h is therefore $\left(\frac{1}{c_v^2} - 1 \right) = .5055$ for this case, and $(h + h') = (h + .5055 h) = H$.

249. Mechanical Effect of the Efflux.—Since the dynamic force of the jet is as the effective head acting upon it, the loss of .505 of h is a matter of importance, especially in cases of short pipes.

The theoretical velocity being = $\frac{v}{.815}$, the *theoretical* energy of the jet, under the same assumed conditions, is $\frac{1}{.815^2} \times \frac{v^2}{2g} \times Q \times w = 321250$ foot pounds per second = 584.09

H.P.; w representing the weight in pounds (= 62.34) per cubic foot of the water, and Q the volume or quantity of water in cubic feet per second.

The energy E , due to v , is expressed by the equation,

$$E = \frac{v^2}{2g} \times Q \times w \quad (2)$$

= 213631.2 foot pounds per second = 388.42 *H.P.*

The loss of energy from the quantity of water Q during the efflux in one second, being proportionate to the loss of head, is,

$$\left(\left\{ \frac{1}{c_v^2} \times \frac{v^2}{2g} \right\} - \frac{v^2}{2g} \right) \times Qw = \left(\frac{1}{c_v^2} - 1 \right) \frac{v^2}{2g} \times Qw. \quad (3)$$

= 107618.75 foot pounds per second = 195.67 *H.P.*

250. Ratio of Resistance at Entrance to a Pipe.

—The ratio, .505 of h' to h , is very nearly a *mean* for tubes whose edges are *square* and *flush* in a plane partition. If the entrance of the tube is well rounded in trumpet-mouth form, corresponding to the form of the *venâ contractâ*, the coefficient of velocity c_v will be increased to about .98, and the ratio of resistance will become $\left(\frac{1}{.98^2} - 1 \right) = .0412$, equal in this case (Fig. 35) to about four feet head, and the head that can be made available for work will equal ninety-six feet.

The disadvantage of the square edges, as respects both volume and dynamic force, is apparent. This resistance of entry of the jet into a tube, whose ratio of head we have determined, is force, or its equivalent head irrecoverably lost. Its maximum for a given head occurs when the tube is about three diameters long, the velocity being then at its maximum, and thereafter its value is reduced as the pipe is lengthened, and with the square of the velocity.

RESISTANCE TO FLOW WITHIN A PIPE.

251. Resistance of Pipe-wall.—We have heretofore considered the whole head H as applied to and entirely utilized in overcoming the resistance of entry of the jet into the pipe, and in generating the velocity among the particles of the jet.

We will now consider the resistances within the pipe and its appendages, and the portion of the velocity that must be converted into pressure or dynamic force to overcome them.

252. Conversion of Velocity into Pressure.—If the pipe P , Fig. 35, of three diameters length, be extended as at P' , a new resistance arising within the added length acts upon the jet and again reduces the volume of flow. A portion of the velocity of the jet is converted into pressure or dynamic force, and is applied to overcome the resistances presented within the pipe, and the proportion of the velocity thus consumed is almost directly proportional to the length added of the pipe, of the given diameter.

253. Coefficients of Efflux from Pipes.—The effects upon the volume of discharge through a given pipe consequent upon varying its length will be apparent upon inspection of a table of coefficients of efflux, c , due to its several lengths respectively.

We will assume the pipe to be one foot diameter, of clean cast iron, when the coefficients determined experimentally have mean values about as follows :

TABLE No. 31.
COEFFICIENTS OF EFFLUX (c) FOR SHORT PIPES.

Lengths, in diameters ..	1	5	10	25	50	75	100	125	150	175	200	225	250	275	300
Coefficients (c).....	.62	.792	.770	.714	.643	.588	.548	.512	.485	.462	.440	.420	.405	.386	.378

Plotted as ordinates, beginning with the theoretical coefficient, unity, they range themselves as in Fig. 36.

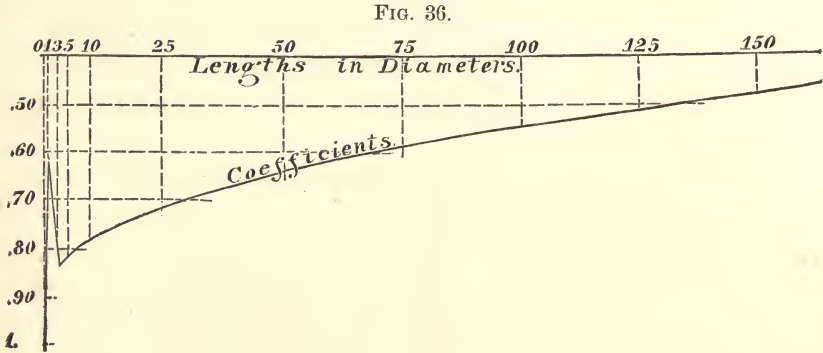

254. Reactions from the Pipe-wall.—A fair sample of ordinary pipe casting, a cement-lined, lead, or glazed earthenware pipe are each termed smooth pipes, but a good magnifying lens reveals upon their surfaces innumerable cavities and projections.

The molecules of water are so minute that many thousands of them might be projected against and react from a single one of those innumerable projections, even though it was inappreciable to the touch, or invisible to the naked eye.

A series of continual reactions and deflections, originated by the roughness of the pipe, act upon the individual molecules as they are impelled forward by gravity, and materially retard* their flow.

In a given pipe, having a uniform character of surface, the sum of the reactions, for a given velocity, is directly as

* The resistance was, by the earlier philosophers, attributed chiefly to the adhesion of the fluid particles to the sides of the pipe, and to the cohesion among the particles. *Vide* Downing, who accepts the views of Du Buat, D'Aubuisson, and other eminent authorities. *Practical Hydraulics*, p. 200. London, 1875.

its wall surface, or as the product of the inner circumference into the length. Since in a pipe of uniform diameter the circumference is constant, the sum of the reactions is also *directly as the length*.

The *impulse* of the flowing particles, and therefore their reactions and eddy influences, are theoretically proportional to the head to which their velocity is due, which is proportional to the square of the velocity, or, in general terms, the effective reactions are proportional nearly to the *square of the velocity*.

The resistances arising from the interior surface of the pipe are, therefore, not only as the *length*, but as the *square of the velocity*, nearly.

The effect of the resistances is not equal upon all the particles in a section of the column of water, but is greatest at the exterior and least at the centre, or, in a given section, approximately *as its circumference divided by a function of its area*.*

255. Origin of Formulas of Flow.—These simple hypotheses constitute the foundation of all the expressions of resistance to the flow of water in pipes, as they appear in the varied, ingenious, and elegant formulas of those eminent philosophers and hydraulicians who have investigated the subject scientifically.

256. Formula of Resistance to Flow.—Place R to represent the sum of all the resistances arising from the circumference of the pipe (excluding those due to the entry); C for the contour or circumference of the pipe, in feet; S for the section of the interior of the pipe, in square feet; l for the length of the pipe, in feet; and v for the mean velocity

* The law of the effects of the resistances is believed to have been first formulated in the simple algebraic expressions now in general use, by M. Chezy, about the year 1775.

of flow, in feet per second. Then the resistance to flow is expressed by the equation

$$R = \frac{C}{S} \times l \times (m) v^2. \quad (4)$$

257. Coefficient of Flow.—In the equation a new coefficient m appears, which also is to be determined by experiment. It is not to be confounded with the c heretofore investigated, but will hereafter be investigated independently.

258. Opposition of Gravity and Reaction.—We have seen that gravity (§ 189) is the natural origin and the accelerating force that produces motion of water in pipes.

Its effect, if no resistance was opposed, would be to continually accelerate the flow. On the other hand, if its effect was removed, the resistances would bring the column to a state of rest.

The two influences oppose each other continually, and therefore tend to the production of a rate of motion in which they balance each other.

259. Conversion of Pressure into Mechanical Effect.—When the motion has become sensibly constant, a portion of the effect of gravity that appeared as velocity in the cases of orifices and short tubes, or its equivalent in the form of pressure or head, has been converted into dynamic force and is acting to overcome the resistances, and the remaining force due to gravity or head is producing the velocity of flow then remaining.

260. Measure of Resistance to Flow.—The effect of the resistance along a main pipe, when discharging water from a reservoir, as in Fig. 37, may be observed by attaching a series of pressure gauges at intervals, or by attaching a series of open-topped pipes, as at p p_1 p_2 , etc.

FIG. 37.

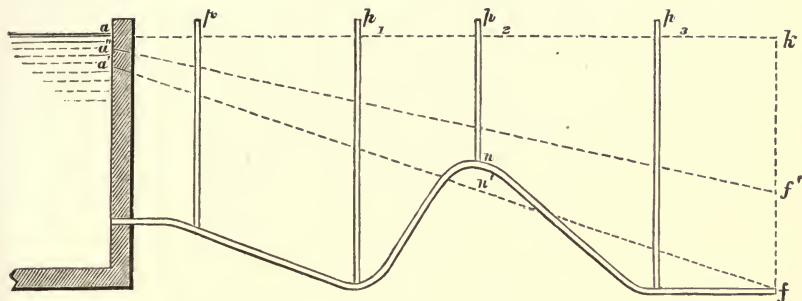

If the end f of the pipe is closed, water will stand in all the vertical pipes at the same level, ak , as in the reservoir.

If the diameter of the pipe is uniform throughout its length, and the flow, the full capacity of the pipe, then water will stand in the several vertical pipes up to the inclined line $a'f$; provided that the top of p_2 be closed so that there may be a tendency to vacuum at n , and provided also that n is not more than thirty feet, or the height to which the pressure of the atmosphere can maintain the pipe full, above the line $a'f$, at n' .

When f is an open end discharging into air, and the vacuum at n is not maintained, $a'n$ will be the total effective head, and the portion of the pipe nf will be only partially filled.

261. Resistance Inversely as the Square of the Velocity.—If the discharge of the pipe is throttled at f , by a partial closing of a valve, by a contraction of the issue, or by diversion of the stream into other pipes of less capacity, and a portion of the velocity is in consequence converted into pressure equivalent to the head $f'f$, then the resistance will be lessened as the square of the velocity decreases, and water will stand in the vertical pipes, or the gauges will indicate the inclined line $a''f'$. This is the usual condition of mains in public water supplies.

262. Increase of Bursting Pressure.—One effect of throttling the discharge is seen to be an increase of bursting pressure upon the pipes, which is greater when the exit is entirely closed than when there is a constant flow, and which decreases as the velocity increases, though a sudden closing of a valve against a rapid current will probably prove disastrous to an ordinary pipe that is fully able to sustain a legitimate pressure due to the head.

263. Acceleration and Resistance.—Let ab (Fig. 38) be a vertical pipe discharging water from a reservoir A , maintained always full. If, before the water entered the

FIG. 38.

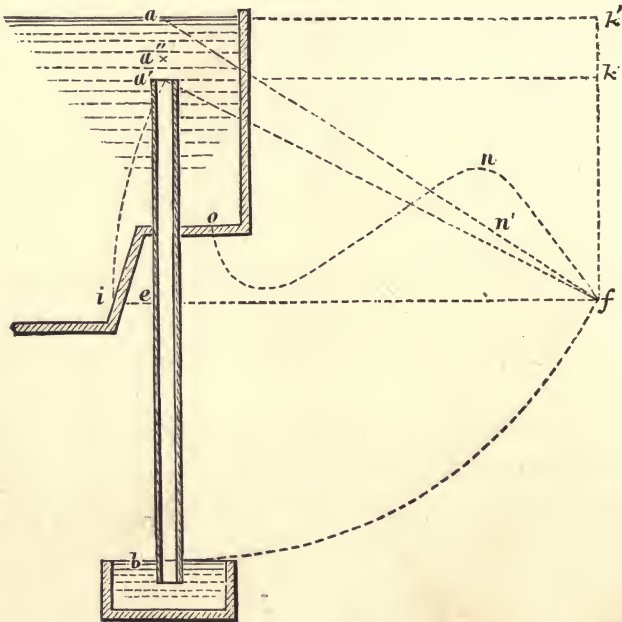

pipe, a single particle had been dropped into its centre from a , the velocity of movement of the particle would, in consequence of the effect of gravity upon it, have been constantly accelerated through its whole passage along the axis.

Its velocity, when it had reached b , would have been equal to $\sqrt{2gH}$, when H represents the vertical height ab in feet.

The greater the height ab the greater the sum of the accelerations by gravity, and also, if the pipe is flowing *full*, the greater the length $a'b$ the greater the sum of the resistances acting upon the column of water to retard it.

264. Equation of Head Required to Overcome the Resistance.—Let v be the velocity of the jet issuing from b , h the head due to v , and h'' the head acting upon the resistance, R .

Then the amount of the force of gravity, or equivalent head, h'' , converted into dynamic force in each second to overcome the resistances within the length of pipe traversed by the jet in one second = $\frac{mC}{S} \times l \times \frac{v^2}{2g}$, and we have the equation,

$$h'' = \frac{mC}{S} \times l \times \frac{v^2}{2g}. \quad (5)$$

representing the resistances overcome per second for the given head and in the given length.

265. Designations of h'' and l .—In long pipes the total head, $H = h + h' + h''$.

The head, or *charge* of water h'' acting upon the resistances, is the vertical height of the surface of the reservoir, less the height $aa'' = h$ (Fig. 38), necessary to generate the velocity v , and also less the height $a''a' = h'$ necessary to overcome the resistance of entry, above the centre of the discharging jet at the exit; or if the discharge is into another body of water, above the surface of the lower body.

The length l to be taken, is the actual length of the axis of the pipe.

Then whatever the position or direction of the pipe $a'b$,

or $a'f$, or if , or onf (abstracting for the present any resistance of curvature), we have for its dynamic equation of resistance to the force of gravity,

$$h'' = \frac{Clm}{S} \times \frac{v^2}{2g} = \frac{Clm}{S} \times h, \quad (6)$$

unless, in the case of a pipe discharging near to its full capacity, an upward curve, n , shall rise more than thirty feet above the line of *hydraulic mean gradient* $a'f$, when h'' is to be taken in two sections, first from a' to n vertically, and second from n to f vertically reduced by the effect of the vacuum, if any, or as a simple channel without pressure if the length nf does not fill.

266. Variable Value of m .—In the equation

$$h'' = \frac{Cl}{S} \times m \frac{v^2}{2g},$$

we have the coefficient m , whose several values are to be deduced from actual measurements of the flow of water through pipes, and whose governing conditions are to be closely observed and studied.

The physical conditions of various pipes are so different that special coefficients are required for each class of conditions.

A slight increase in the roughness of the interior surface of the pipe, occasional sudden enlargements or contractions of the diameter of the pipe, and sudden bends in the direction of the pipe, may be instanced as sufficient departures from the conditions of straight pipes with uniform diameters and surfaces to materially modify the value of its coefficient of flow.

267. Investigation of Values of m .—For the determination of a series or table of coefficients, m , for full

pipes, we will select data from published tables of* experiments by Henry Darcy, made while he was director of the public water service of the city of Paris; from† experiments by Geo. S. Greene, made while chief engineer of the Croton Aqueduct Department of New York city; from experiments by Geo. H. Bailey, Esq., made while chief engineer of the Jersey City Water-works; from some of the famous experiments of Du Buat, Couplet, and Bossut, which furnished the chief data for the elegant formulas of those eminent philosophers, as well as those of Prony‡ and Eytelwein, and from several other sources.

268. Definition of Symbols.—By transposition we have

$$m = 2g \times \frac{S}{C} \times \frac{h}{l} \times \frac{1}{v^2}. \quad (7)$$

The member $\frac{h}{l}$ is the ratio of the height which the particles fall through in the given length, equal $\frac{\text{height}}{\text{length}}$, or the sine of the angle of inclination $ka'f$, Fig. 38. The inclination $a'f$ is termed the “*slope*,” or the *hydraulic mean gradient*, and is usually designated by the letter i . The point a' is always beneath the surface of the water a depth aa' necessary to generate the velocity v in the pipe, and to overcome the resistance of entry, whether the pipe be in the position $a'f$, if , or onf .

The depth aa' varies as the velocity varies, and the “*slope*” i corresponds to an imaginary right line connecting the points a' and f .

* Recherches experimentales relatives au mouvement de l'eau dans le tuyaux. Paris, 1857.

† Descriptive Memoir of the Brooklyn Water-works, by James P. Kirkwood. Van Nostrand, N. Y., 1867.

‡ Vide Recherches Physico-Mathématiques sur la Théorie du Mouvement des Eaux Courantes, 1804.

The member $\frac{S}{C}$, as now inverted (§ 256) refers to the ratio of the section to the contour of the given pipe, or to the sectional area. It is termed the "*mean radius*," or, in wetted perimeter. ** It is termed the "mean radius," or, in the cases of pipes and channels partially filled, the hydraulic mean depth, and is usually designated by the letter r. The value of r for full pipes is always equal to one-fourth of the diameter = $\frac{d}{4}$, according to well-known properties of the circle.*

269. Experimental Values of the Coefficient of Flow.—We have then, as an equivalent for equation (7) :

$$m = \frac{2gri}{v^2}, \quad \text{or} \quad m = \frac{2ghS}{Cv^2}. \quad (8)$$

** Area of circle = $\frac{\pi d^2}{4}$*
Circumf " = πd
Ratio = $\frac{S}{C} = \frac{d}{4}$

TABLE No. 52.

EXPERIMENTAL COEFFICIENTS (m) OF FLOW OF WATER IN *Clean*PIPES, UNDER PRESSURE. $m = \frac{2ghS}{Clv^2} = \frac{2gri}{v^2}$.

EXPERIMENTS BY H. DARCY (Cast-iron Pipes).

Diameter = d , in feet.	Head = h , in feet.	Length = l , in feet.	Velocity = v , in feet per sec.	Coefficient = m .
0.2687	0.066	328.09	0.2885	.0104478
"	1.742	"	1.8399	.0067800
"	3.347	"	2.5946	.0065508
"	13.260	"	5.1509	.0065850
"	39.299	"	8.9242	.0065162
"	56.011	"	10.7115	.0064320
0.4501	0.079	328.09	0.4887	.0073054
"	.686	"	1.6021	.0059026
"	1.558	"	2.5021	.0054960
"	54.975	"	15.3929	.0051240
0.6151	0.089	328.09	0.6544	.0062884
"	1.207	"	2.4991	.0058476
"	2.641	"	3.7155	.0057898
"	4.369	"	4.9045	.0055296
"	12.500	"	8.2564	.0055482
"	47.872	"	16.2360	.0054948
0.9751	0.092	328.09	0.7997	.0068802
"	.883	"	2.7134	.0057306
"	1.762	"	3.7863	.0058728
"	3.625	"	5.4039	.0059314
"	7.562	"	7.8330	.0058890
"	13.473	"	10.3575	.0060010
1.6427	0.148	328.09	1.3765	.0062950
"	.148	"	1.4685	.0055310
"	.197	"	1.5549	.0065688
"	.394	"	2.5954	.0047160
"	.853	"	3.6637	.0051216
"	.820	"	3.6900	.0048536

TABLE No. 53.

EXPERIMENTAL COEFFICIENTS (m) OF FLOW OF WATER IN *Clean*

$$\text{PIPES, UNDER PRESSURE. } m = \frac{2ghS}{Clv^2} = \frac{2gri}{v^2}.$$

EXPERIMENTS BY THE WRITER (Wrought-iron Cement-lined Pipe).

Diameter = d , in feet.	Head = h , in feet.	Length = l , in feet.	Velocity = v , in feet per sec.	Coefficient = m .
1.6667	1.86	8171.0	0.949	.006360
"	3.60	"	1.488	.005335
"	5.93	"	1.925	.005251
"	8.48	"	2.329	.005347
"	10.93	"	2.598	.005313
"	12.91	"	2.867	.005153
"	16.28	"	3.271	.004993
"	18.60	"	3.439	.005160
"	22.22	"	3.741	.005209
"	24.54	"	3.920	.005115
"	25.58	"	4.00	.005110
"	26.16	"	4.04	.005100

TABLE No. 54.

EXPERIMENTS BY DU BUAT (Tin Pipes).

0.0889	.973	10.401	5.179	.004992
"	1.484	10.401	6.334	.005089
"	.0481	12.304	0.7717	.009393
"	.375	12.304	2.606	.006424
"	1.220	12.304	5.220	.005207
"	.013	65.457	0.1411	.014276
"	1.022	"	1.775	.007091
"	1.954	"	2.546	.006585

TABLE No. 55.

EXPERIMENTS BY BOSSUT (Tin Pipes).

0.0889	0.331	53.284	1.085	.001698
"	.976	86.094	1.979	.004142
.11841	.864	31.956	2.945	.005943
"	2.066	191.840	1.679	.007282
"	1.699	31.956	4.308	.005461
.178	.765	31.956	3.581	.005363
"	2.019	191.840	2.196	.006270
"	1.892	95.905	2.250	.011190
"	1.491	31.956	5.230	.004901

TABLE No. 56.

EXPERIMENTAL COEFFICIENTS (m) OF FLOW OF WATER IN *Clean*PIPES, UNDER PRESSURE. $m = \frac{2ghS}{Clv^2}$.

EXPERIMENTS BY COUPLET (Iron Pipes).

Diameter = d , in feet.	Head = h , in feet.	Length = l , in feet.	Velocity = v , in feet per sec.	Coefficient = m .
0.4439	0.492	7481.88	0.1785	.001475
"	1.005	7481.88	.2802	.012230
.4374	1.484	7481.88	.3665	.010390
"	1.670	"	.4258	.008667
"	2.130	"	.4640	.009309
"	2.215	"	.4728	.009323
1.5988	12.629	3836.66	3.4779	.007004

TABLE No. 57.

EXPERIMENTS BY W. A. PROVIS. (Lead Pipes.)

0.125	2.91666	20.00	6.1495	.006465
"	"	40.00	4.7588	.005398
"	"	60.00	3.9032	.005360
"	"	80.00	3.3961	.005287
"	"	100.00	3.0897	.005122

TABLE No. 58.

EXPERIMENTS BY RENNIE.

With glass pipes slightly rounded at the ends.

0.0020833	1.0	1.0	7.1627	.000653
"	2	"	10.4196	.000408
"	3	"	12.9409	.000601
"	4	"	14.6240	.000627
.0041666	1.0	1.0	5.6450	.001672
"	2	"	8.3676	.001916
"	3	"	10.0497	.001992
"	4	"	11.6000	.001994
.00625	1.0	1.0	5.5487	.004162
"	2	"	8.1852	.004814
"	3	"	9.8551	.003956
"	4	"	10.8320	.004378
.00833	1.0	1.0	6.1028	.004584
"	2	"	8.5386	.004684
"	3	"	10.8003	.004392
"	4	"	13.0400	.004016

TABLE No. 59.

EXPERIMENTAL COEFFICIENTS (m) OF FLOW OF WATER IN *Old*
 PIPES, UNDER PRESSURE. $m = \frac{2ghS}{Clv^2}$.

EXPERIMENTS BY H. DARCY. (Foul Iron Pipes.)

Diameter = d , in feet.	Head = h , in feet.	Length = l , in feet.	Velocity = v , in feet per sec.	Coefficient = m .
0.1194	0.223	328.09	0.2669	.018342
"	.600	"	.4273	.019210
"	2.198	"	.8291	.018735
"	5.003	"	1.2494	.018784
"	10.630	"	1.8079	.019055
"	13.632	"	2.0772	.018511
0.2628	0.213	328.09	0.4040	.016811
"	.820	"	.8242	.015551
"	2.379	"	1.4645	.014288
"	5.282	"	2.2226	.013774
"	10.171	"	3.0517	.014082
"	14.879	"	3.7434	.013679
0.8028	0.308	328.09	1.0080	.011934
"	.663	"	1.4824	.011878
"	1.552	"	2.3218	.011334
"	3.773	"	3.6283	.011285
"	7.513	"	5.0727	.011494
"	10.499	"	6.0169	.011417
"	13.468	"	6.8037	.011454
"	45.870	"	12.5779	.011415

TABLE No. 60.

EXPERIMENT BY GEN. GEO. S. GREENE, C. E.,

Upon a New York City cast-iron Main. (Tuberculated.)

3.0 | 20.215 | 11217.00 | 2.99967 | .00966

EXPERIMENT BY GEO. H. BAILEY, C. E.,

Upon a Jersey City cast-iron Main. (Tuberculated.)

1.6667 | 28.1285 | 29715.00 | 1.43795 | .01228

TABLE 60.—(Continued.)

EXPERIMENTAL COEFFICIENTS (m) OF FLOW OF WATER IN *Old*PIPES, UNDER PRESSURE. $m = \frac{2ghS}{Clv^2}$.

EXPERIMENT UPON THE COLINTON MAIN.*

Eight years in use.

Diameter = d , in feet.	Head = h , in feet.	Length = l , in feet.	Velocity = v , in feet per sec.	Coefficient = m .
1.3334	184	3815	14.500	.004923
“	230	25765	5.252	.005556
“	420	29580	6.816	.006559

LAMBETH WATER WORKS MAIN.

2.5	25	54120	1.772	.005918
1.583	41	22440	2.734	.006229
1	38	5200	4.353	.006208

LIVERPOOL WATER WORKS MAIN.

1	27	8140	2.644	.007633
---	----	------	-------	---------

CARLISLE WATER WORKS MAIN.

1	34.5	6600	3.568	.006610
---	------	------	-------	---------

EXPERIMENTS BY THE WRITER.

With unlined wrought iron pipe (gas tubing), the jet entering through a stop-cock and piston meter, with coefficient $c = .58$ when length = 0.25. The pipe had been in use one week, but had rusted considerably.

0.08334	28.73	0.25	46.70
“	85.57	9	18.964	.035467
“	98.34	735	4.850	.007636
“	96.38	1337	3.538	.007722
“	87.33	2040	2.722	.007746

* *Vide* Proceedings of Inst. Civ. Engineers, p. 4, Feb. 6th, 1855, London.

TABLE No. 61.

SERIES OF COEFFICIENTS OF FLOW (m) OF WATER IN CLEAN PIPES,
UNDER PRESSURE, AT DIFFERENT VELOCITIES, AND IN PIPES

OF DIFFERENT DIAMETERS. $\left(m = \frac{2ghS}{Clv^2} = \frac{2grl}{v^2}\right)$.

VELOCITY.	DIAMETERS.					
	$\frac{1}{8}$ inch. .0417 ft.	$\frac{3}{8}$ " .0625'	1" .0834'	1½" .1250'	1¾" .1458'	2" .1667'
<i>Feet per Second.</i>	<i>Coefficient.</i>	<i>Coefficient.</i>	<i>Coefficient.</i>	<i>Coefficient.</i>	<i>Coefficient.</i>	<i>Coefficient.</i>
.1	0.0150	0.0130	0.0119	0.0107	0.00970	0.00870
.2	.0143	.0126	.0116	.0105	.00952	.00860
.3	.0137	.0123	.0113	.0103	.00937	.00850
.4	.0133	.0119	.0110	.0100	.00920	.00840
.5	.0128	.0116	.0107	.00984	.00904	.00830
.6	.0124	.0113	.0104	.00960	.00890	.00822
.7	.0120	.0111	.0102	.00940	.00873	.00813
.8	.0116	.0108	.0100	.00922	.00860	.00804
.9	.0113	.0105	.00972	.00910	.00850	.00798
1.0	.0110	.0102	.00950	.00893	.00840	.00790
1.1	.0107	.00995	.00933	.00880	.00826	.00783
1.2	.0104	.00973	.00913	.00867	.00817	.00776
1.3	.0101	.00952	.00898	.00854	.00809	.00770
1.4	.00992	.00930	.00882	.00843	.00800	.00763
1.5	.00959	.00910	.00868	.00832	.00793	.00757
1.6	.00942	.00890	.00854	.00823	.00786	.00750
1.7	.00920	.00872	.00840	.00814	.00777	.00746
1.8	.00900	.00856	.00830	.00806	.00769	.00741
1.9	.00880	.00842	.00820	.00800	.00763	.00736
2.0	.00862	.00830	.00810	.00790	.00757	.00731
2.25	.00840	.00804	.00785	.00770	.00742	.00721
2.5	.00795	.00780	.00768	.00752	.00730	.00710
2.75	.00775	.00761	.00750	.00736	.00716	.00700
3.0	.00753	.00745	.00734	.00722	.00707	.00692
3.5	.00732	.00722	.00712	.00702	.00692	.00680
4	.00722	.00710	.00702	.00692	.00682	.00671
5	.00704	.00693	.00684	.00675	.00664	.00654
6	.00689	.00678	.00670	.00660	.00650	.00640
7	.00675	.00664	.00657	.00648	.00639	.00629
8	.00663	.00652	.00646	.00638	.00627	.00618
9	.00652	.00643	.00636	.00628	.00618	.00609
10	.00644	.00634	.00628	.00620	.00610	.00601
12	.00630	.00620	.00614	.00607	.00599	.00590
14	.00622	.00613	.00606	.00600	.00592	.00584
16	.00618	.00608	.00600	.00595	.00589	.00581
18	.00616	.00606	.00599	.00594	.00588	.00580
20	.00615	.00605	.00598	.00593	.00587	.00579

TABLE No. 61—(Continued).

COEFFICIENTS OF FLOW (m) OF WATER IN CLEAN IRON PIPES
UNDER PRESSURE.

VELOCITY.	DIAMETERS.					
	3 inch .250 feet.	4" .3333'.	6" .5'.	8" .6667'.	10" .8333'.	12" 1.0'.
<i>Feet per Second.</i>	<i>Coefficient.</i>	<i>Coefficient.</i>	<i>Coefficient.</i>	<i>Coefficient.</i>	<i>Coefficient.</i>	<i>Coefficient.</i>
.1	0.00800	0.00763	0.00730	0.00704	0.00684	0.00669
.2	.00792	.00755	.00724	.00698	.00678	.00662
.3	.00784	.00750	.00720	.00693	.00673	.00657
.4	.00780	.00742	.00713	.00688	.00668	.00652
.5	.00774	.00737	.00708	.00682	.00663	.00648
.6	.00767	.00732	.00702	.00677	.00659	.00642
.7	.00760	.00727	.00697	.00673	.00654	.00638
.8	.00754	.00722	.00693	.00668	.00651	.00633
.9	.00750	.00718	.00688	.00663	.00648	.00629
1.0	.00743	.00712	.00684	.00659	.00643	.00624
1.1	.00739	.00708	.00679	.00654	.00640	.00620
1.2	.00733	.00704	.00674	.00652	.00635	.00617
1.3	.00729	.00700	.00670	.00648	.00632	.00613
1.4	.00724	.00697	.00666	.00644	.00628	.00610
1.5	.00720	.00693	.00662	.00640	.00625	.00607
1.6	.00716	.00690	.00658	.00637	.00622	.00603
1.7	.00712	.00687	.00655	.00633	.00618	.00601
1.8	.00708	.00684	.00652	.00630	.00615	.00599
1.9	.00703	.00680	.00650	.00628	.00612	.00597
2.	.00700	.00678	.00648	.00624	.00609	.00593
2.25	.00690	.00670	.00640	.00617	.00603	.00588
2.50	.00683	.00662	.00634	.00611	.00596	.00581
2.75	.00675	.00655	.00629	.00605	.00590	.00575
3.	.00670	.00650	.00623	.00600	.00584	.00570
3.5	.00660	.00640	.00614	.00593	.00574	.00561
4.	.00651	.00631	.00607	.00586	.00568	.00553
5.	.00636	.00618	.00594	.00573	.00558	.00543
6.	.00622	.00605	.00582	.00562	.00548	.00534
7.	.00610	.00595	.00572	.00552	.00540	.00527
8.	.00600	.00587	.00562	.00544	.00532	.00520
9.	.00593	.00578	.00555	.00538	.00525	.00512
10.	.00585	.00572	.00549	.00530	.00520	.00508
12.	.00582	.00560	.00540	.00522	.00512	.00500
14.	.00573	.00554	.00533	.00516	.00507	.00494
16.	.00570	.00552	.00530	.00513	.00502	.00491
18.	.00576	.00550	.00528	.00510
20.	.00566	.00549

TABLE No. 61—(Continued).

COEFFICIENTS OF FLOW (m) OF WATER IN CLEAN CAST-IRON
PIPES UNDER PRESSURE.

VELOCITY.	DIAMETERS.					
	14 inches 1.1667 feet.	16" 1.3333'.	18" 1.5'.	20" 1.6667'.	24" 2.0'.	27" 2.25'.
<i>Feet per Second.</i>	<i>Coefficient.</i>	<i>Coefficient.</i>	<i>Coefficient.</i>	<i>Coefficient.</i>	<i>Coefficient.</i>	<i>Coefficient.</i>
.1	0.00650	0.00623
.2	.00644	.00619	0.00600	0.00583
.3	.00640	.00614	.00597	.00578	0.00548	0.00530
.4	.00634	.00611	.00592	.00574	.00544	.00526
.5	.00630	.00607	.00588	.00570	.00540	.00523
.6	.00625	.00603	.00584	.00567	.00537	.00520
.7	.00621	.00600	.00580	.00563	.00533	.00517
.8	.00617	.00597	.00577	.00561	.00531	.00513
.9	.00612	.00593	.00573	.00558	.00528	.00511
1.0	.00609	.00588	.00570	.00555	.00525	.00508
1.1	.00605	.00584	.00568	.00552	.00522	.00505
1.2	.00601	.00581	.00564	.00550	.00520	.00503
1.3	.00598	.00578	.00561	.00548	.00517	.00500
1.4	.00593	.00575	.00559	.00545	.00514	.00498
1.5	.00590	.00572	.00556	.00542	.00512	.00495
1.6	.00587	.00569	.00553	.00539	.00510	.00493
1.7	.00584	.00566	.00551	.00536	.00508	.00491
1.8	.00582	.00563	.00549	.00534	.00506	.00489
1.9	.00579	.00561	.00546	.00532	.00503	.00487
2.0	.00576	.00559	.00543	.00529	.00501	.00485
2.25	.00570	.00553	.00538	.00524	.00497	.00480
2.50	.00564	.00548	.00533	.00518	.00492	.00475
2.75	.00559	.00543	.00528	.00513	.00488	.00472
3.	.00554	.00538	.00523	.00509	.00483	.00468
3.5	.00547	.00529	.00516	.00502	.00478	.00462
4.	.00540	.00524	.00511	.00498	.00473	.00458
5.	.00530	.00515	.00501	.00490	.00466	.00451
6.	.00520	.00507	.00495	.00482	.00460	.00446
7.	.00512	.00500	.00489	.00476	.00453	.00440
8.	.00503	.00491	.00483	.00470	.00450	.00435
9.	.00498	.00489	.00478	.00466	.00445	.00431
10.	.00493	.00483	.00473	.00462	.00443	.00429
12.	.00487	.00478	.00468	.00457	.00440	.00429
14.	.00482	.00473	.00463	.00452	.00434	.00422
16.	.00480	.00470	.00460	.00450	.00432	.00420

TABLE No. 61—(Continued).

COEFFICIENTS OF FLOW (*m*) OF WATER IN CLEAN CAST-IRON
PIPES, OR SMOOTH MASONRY, UNDER PRESSURE.

VELOCITY.	DIAMETERS.					
	30 inch 2.5' feet.	33'' 2.75'.	36'' 3.0'.	40'' 3.3333'.	44'' 3.6667'.	48'' 4.0'.
<i>Feet per Second.</i>	<i>Coefficient.</i>	<i>Coefficient.</i>	<i>Coefficient.</i>	<i>Coefficient.</i>	<i>Coefficient.</i>	<i>Coefficient.</i>
.4	0.00510	0.00497	0.00476
.5	.00507	.00492	.00473	0.00436	0.00420	0.00400
.6	.00504	.00490	.00471	.00434	.00418	.00399
.7	.00501	.00488	.00469	.00432	.00416	.00398
.8	.00498	.00485	.00467	.00431	.00414	.00397
.9	.00495	.00482	.00464	.00430	.00412	.00396
1.0	.00492	.00480	.00462	.00428	.00411	.00395
1.1	.00490	.00478	.00459	.00426	.00410	.00394
1.2	.00488	.00475	.00457	.00424	.00409	.00393
1.3	.00486	.00472	.00455	.00423	.00407	.00392
1.4	.00484	.00470	.00453	.00422	.00406	.00391
1.5	.00482	.00468	.00451	.00421	.00404	.00390
1.6	.00480	.00466	.00450	.00400	.00403	.00388
1.7	.00477	.00464	.00448	.00419	.00402	.00387
1.8	.00475	.00462	.00446	.00418	.00401	.00386
1.9	.00473	.00460	.00444	.00417	.00400	.00385
2.	.00470	.00458	.00442	.00416	.00399	.00384
2.25	.00465	.00453	.00437	.00413	.00397	.00382
2.5	.00460	.00449	.00432	.00410	.00394	.00380
2.75	.00456	.00444	.00428	.00408	.00391	.00378
3.	.00452	.00440	.00424	.00407	.00389	.00376
3.5	.00446	.00434	.00419	.00402	.00386	.00373
4.	.00441	.00430	.00415	.00400	.00383	.00370
5.	.00436	.00423	.00410	.00395	.00381	.00366
6.	.00430	.00418	.00405	.00391	.00377	.00363
7.	.00427	.00413	.00401	.00388	.00373	.00361
8.	.00422	.00410	.00398	.00384	.00371	.00358
9.	.00418	.00407	.00395	.00382	.00370	.00355
10.	.00415	.00404	.00392	.00380	.00367	.00353
12.	.00412	.00400	.00389	.00377	.00364	.00351
14.	.00409	.00397	.00386	.00373	.00363	.00350
16.	.00406	.00395

TABLE No. 61—(Continued).

COEFFICIENTS OF FLOW (m) OF WATER IN CLEAN CAST-IRON PIPES,
OR SMOOTH MASONRY, UNDER PRESSURE.

VELOCITY.	DIAMETERS.				
	54 inches. 4.5 feet.	60'' 5.0'.	72'' 6.0'.	84'' 7.0'.	96'' 8.0'.
<i>Feet per second.</i>	<i>Coefficient.</i>	<i>Coefficient.</i>	<i>Coefficient.</i>	<i>Coefficient.</i>	<i>Coefficient.</i>
.4
.5	0.00378	0.00358	0.00339	0.00318	0.00290
.6	.00377	.00357	.00338	.00317	.00289
.7	.00376	.00356	.00337	.00317	.00288
.8	.00375	.00355	.00336	.00316	.00287
.9	.00374	.00354	.00335	.00315	.00286
1.0	.00373	.00353	.00334	.00314	.00286
1.1	.00372	.00352	.00333	.00313	.00285
1.2	.00371	.00351	.00332	.00313	.00285
1.3	.00370	.00350	.00332	.00312	.00285
1.4	.00369	.00350	.00331	.00312	.00284
1.5	.00368	.00349	.00331	.00311	.00284
1.6	.00368	.00348	.00330	.00311	.00284
1.7	.00367	.00347	.00329	.00310	.00283
1.8	.00366	.00347	.00329	.00309	.00283
1.9	.00365	.00346	.00328	.00309	.00283
2	.00364	.00346	.00328	.00308	.00282
2.25	.00362	.00344	.00327	.00307	.00282
2.5	.00360	.00342	.00325	.00306	.00281
2.75	.00358	.00341	.00323	.00305	.00280
3	.00357	.00339	.00321	.00302	.00278
3.5	.00353	.00337	.00320	.00300	.00276
4	.00350	.00333	.00318	.00298	.00274
5	.00345	.00329	.00313	.00294	.00272
6	.00340	.00324	.00310	.00292	.00268
7	.00338	.00322	.00308	.00289	.00266
8	.00335	.00320	.00304	.00286	.00264
9	.00332	.00318	.00302	.00283	.00262
10	.00331	.00316	.00300	.00282	.00261
12	.00330	.00313	.00299	.00280	.00260
14	.00329	.00312	.00298	.00279	.00259

270. Peculiarities of the Coefficient (m) of Flow.—

In the tables and diagram of coefficients (m) of flow in pipes, as well as in those of coefficients of discharge (c) through orifices, there is variation in value with each variation in velocity of the jet. In the case of pipes, there is also a variation with the variation of diameter of jet, that equally demands attention.

It will be observed in the tables of experiment above quoted that the coefficient decreases as the diameter or *hydraulic mean radius* increases, and also that with a given diameter the coefficient decreases as the velocity increases; thus, with a given low velocity, we may trace the decrease of the coefficient from 0.0128 for a half-inch pipe to 0.0029 for a ninety-six inch pipe; and with a given diameter of one-half inch we may trace the decrease of the coefficient from 0.0128 for .5 foot velocity per second to 0.00622 for 14 feet velocity per second, and with a given diameter of 96 inches we may trace the decrease of the coefficient from 0.0029 for a velocity of .5 foot per second to 0.00259 for a velocity of 14 feet per second.

We have then a large range of coefficients applicable to clean, smooth, and straight bores. When the bores are of coarse grain, or are slightly tuberculated, the range is still greater, and the values of coefficients of the smaller diameters quite sensibly affected; and if the bores are very rough or tuberculated, the values of coefficient for small diameters and low velocities are very much augmented.

271. Effects of Tubercles.—These effects, in tuberculated pipes, as compared with clean pipes, are illustrated in the following approximate table, which we have endeavored to adjust to a common velocity of three feet per second for all the diameters. The data for very foul pipes is however scanty, though sufficient to show that the coefficients do in

extreme cases exceed the limits given for the small diameters; and that conditions from clean to foul may occur, with the several diameters, that shall cover the entire range from minimum to maximum coefficients, and calling for a careful exercise of judgment founded upon experience.

TABLE No. 62.

COEFFICIENTS FOR CLEAN, SLIGHTLY TUBERCULATED, AND FOUL PIPES, OF GIVEN DIAMETERS, AND WITH A COMMON VELOCITY OF 3 FEET

PER SECOND.
$$\left(v = \left\{ \frac{2ghd}{(4m)l} \right\}^{\frac{1}{2}} = \left\{ \frac{2gri}{m} \right\}^{\frac{1}{2}} \right).$$

Hydraulic Mean Radius, $\frac{S}{C} = \frac{d}{4}$	Diameter.		Clean.	Slightly tuberculated.	Foul.
	Feet.	Inches.	Coef., m.	Coef., m.	Coef., m.
.0104	.0417	$\frac{1}{2}$	0.00753
.0156	.0625	$\frac{3}{4}$.00745
.0208	.0834	1	.00734	0.00982
.0312	.1250	$1\frac{1}{2}$.00722	.00940
.0364	.1458	$1\frac{3}{4}$.00707	.00925
.0417	.1667	2	.00692	.00910	0.01400
.0625	.2500	3	.00670	.00862	.01300
.0833	.3334	4	.00650	.00825	.01200
.1250	.5000	6	.00623	.00772	.01100
.1667	.6667	8	.00600	.00733	.00922
.2083	.8334	10	.00584	.00706	.00868
.2500	1.0000	12	.00510	.00680	.00828
.2917	1.1667	14	.00554	.00657	.00792
.3333	1.3333	16	.00538	.00636	.00760
.3750	1.5000	18	.00523	.00616	.00733
.4167	1.6667	20	.00509	.00598	.00710
.5000	2.0000	24	.00483	.00567	.00664
.5625	2.2500	27	.00468	.00544	.00635
.6250	2.5000	30	.00452	.00525	.00604
.6875	2.7500	33	.00440	.00507	.00578
.7500	3.0000	36	.00424	.00490	.00554
.8333	3.3333	40	.00407	.00466	.00524
.9167	3.6667	44	.00389	.00443	.00500
1.0000	4.0000	48	.00376	.00422	.00477

272. Classification of Pipes and their Mean Coefficients.—In ordinary calculations, the mean coefficient for medium diameters and velocities may be taken, for clean pipes, as .00644; for rough or slightly tuberculated pipes, as .0082; and for very rough or very foul pipes, as .012. These coefficients apply approximately to pipes of about five inches diameter, when the velocities are about three feet per second, reference being made to the diameter of the pipe itself when clean.

273. Equation of the Velocity Neutralized by Resistance to Flow.—Having now developed the several values of m as applicable to the several conditions of pipes, we will again transpose our equation and remove v , the member expressing velocity of flow, to one side by itself, and we have the equation of velocity of flow :

$$v = \left\{ \frac{2ghS}{Clm} \right\}^{\frac{1}{2}} \quad \text{or} \quad v = \left\{ \frac{2gri}{m} \right\}^{\frac{1}{2}}$$

$$\text{or} \quad v = \left\{ \frac{2gdi}{4m} \right\}^{\frac{1}{2}} \quad \text{or} \quad v = \left\{ \frac{2ghd}{(4m)l} \right\}^{\frac{1}{2}}$$

$$\text{or} \quad v = \left\{ \frac{2ghr}{ml} \right\}^{\frac{1}{2}} \quad (8)$$

In which h = the ~~head to which the velocity is due, in feet.~~ *resistance head in feet.*

l = the length of the pipe, in feet.

d = the internal diameter of the pipe, in feet.

C = the contour of the unit of length of pipe, in feet.

S = the sectional area of the pipe, in square feet.

i = the sine of inclination = $\frac{h}{l}$.

r = the hydraulic mean radius = $\frac{S}{C} = \frac{d}{4}$.

$g = 32.2$.

274. Equation of Resistance Head.—By transposition again we have the equation for that portion, h'' , of the total head H included in the slope i :

$$h'' = \frac{Clmv^2}{2gS} \quad \text{or} \quad h'' = \frac{(4m)lv^2}{2gd}$$

$$\text{or} \quad h'' = m \frac{l}{r} \times \frac{v^2}{2g} \quad (9)$$

Let c_r represent the ratio of h' to h , or coefficient of resistance of entry of the jet $= \left(\frac{1}{c_v^2} - 1\right) = \left(\frac{1}{c^2} - 1\right)$.

275. Equation of Total Head.—Then

$$H = \frac{v^2}{2g} + c_r \frac{v^2}{2g} + \left(m \frac{l}{r}\right) \frac{v^2}{2g}$$

or*
$$H = \left(1 + c_r + m \frac{l}{r}\right) \frac{v^2}{2g} \quad (10)$$

and
$$v = \left\{ \frac{2gH}{\left(1 + c_r\right) + m \frac{l}{r}} \right\}^{\frac{1}{2}} \quad (11)$$

also, when c is the coefficient of discharge,

$$v = \sqrt{2gH} \times \left\{ \frac{1}{\frac{1}{c^2} + \left(m \frac{l}{r}\right)} \right\}^{\frac{1}{2}} \quad (12)$$

276. Equation of Volume.—The velocity v having been ascertained, we have, for volume of flow q per second,

$$v = \frac{q}{.7854d^2} \quad \text{and} \quad q = .7854d^2v;$$

* Compare Weisbach's Mechanics of Engineering, translated by E. B. Coxe, A. M. N. Y., 1870, p. 870.

also, we have

$$\frac{q}{.7854d^2} = \sqrt{2gH} \times \left\{ \frac{1}{(1 + c_r) + 4m \frac{l}{d}} \right\}^{\frac{1}{2}}$$

or
$$q = .7854\sqrt{2g} \times \left\{ \frac{Hd^5}{(1 + c_r)d + 4ml} \right\}^{\frac{1}{2}}$$

or
$$q = 6.303 \left\{ \frac{Hd^5}{(1 + c_r)d + 4ml} \right\}^{\frac{1}{2}} \quad (13)$$

277. Equation of Diameter.—By transposition again for the value of d , we have

$$d^5 = \frac{1}{6.303^2} \times \left\{ (1 + c_r)d + 4ml \frac{q^2}{H} \right\}$$

or
$$d = .4788 \left\{ (1 + c_r)d + 4ml \frac{q^2}{H} \right\}^{\frac{1}{5}} \quad (14)$$

In this last equation of d , the assistance of the table of velocities for given slopes and diameters (p. 259), and the table of coefficients, m , for given velocities and diameters (§ 269, p. 242), will be required, since the unknown quantities d and m appear in the equation. The approximate values of d and m for the given velocity can be taken from the tables and inserted in the right-hand side of the equation, and a close value of d worked out for a first approximation, and then the operation repeated for a closer value of d , if necessary.

278. Relative Values of Subdivisions of Total Head.—Referring again to the extended pipe, P' , Fig. 35, assume it to be 1000 feet long, horizontal, 1 foot diameter, and under a constant head of 100 feet; then the velocity of discharge, according to equation (11) will be

$$v = \left\{ \frac{64.4 \times 100}{1 + .505 + .00495 \frac{1000}{.25}} \right\}^{\frac{1}{2}} = 17.386 \text{ feet per second ;}$$

and
$$h = \frac{v^2}{2g} = 4.694 \text{ feet.}$$

$$h' = .505 \frac{v^2}{2g} = 2.370 \text{ "}$$

$$h'' = \left(.00495 \frac{1000}{.25} \right) \frac{v^2}{2g} = 92.941 \text{ "}$$

and
$$H = h + h' + h'' = 100.0 \text{ feet.}$$

279. Many Popular Formulas Incomplete.—The fact that the majority of popular formulas for flow of water in pipes, *as usually quoted* in cyclopedias and text-books, refer to $h' + h''$, or in some cases to h'' only, and not to H , has led us to treat the subdivisions of H more minutely in detail than would otherwise have been necessary.

Serious errors are liable to result from the application of such hydrodynamic formulæ by persons not familiar with their origin, especially when the problem includes a *high* head of water and *short* length of pipe.

We believe that the coefficient of flow, m , has not heretofore been as fully developed as its importance has demanded.

280. Formula of M. Chezy.—The formula of M. Chezy, proposed a century ago, and into which nearly all expressions for the same object, since introduced, can be resolved, refers to h'' only, or $h' + h''$, and not to H . When stated in the symbols herein used, it becomes

$$v = \left\{ \frac{ghS}{Clm'} \right\}^{\frac{1}{2}}.$$

As g is introduced in place of $2g$ in our equation, m' will equal $\frac{m}{2}$.

281. Various Popular Formulas Compared.—The value of treating the question of flow of water in pipes in detail may perhaps best be illustrated by computing the velocity of flow from our pipe P' , Fig. 35, as it is extended to different lengths, from 5 feet to 10,000 feet, by a complete formula, with m at its legitimate value, and then computing the same by several prominent formulas, in the form in which they are usually quoted. (See Table No. 63, p. 254.)

282. Sub-heads Compared.—If we compute the total head, to which the velocities, found by the first formula of the table, are due, we shall have the sub-heads, as follows; when $d = 1$ foot.

$$H = 1 + .505 + \left(m \frac{l}{r}\right) \cdot \frac{v^2}{2g} = \left(\frac{v^2}{2g}\right) + \left(c_r \frac{v^2}{2g}\right) + \left(m \frac{l}{r} \frac{v^2}{2g}\right).$$

LENGTHS IN FEET.	5.	50.	100.	1000.	10,000
VELOCITIES IN FT. PER SECOND.	63.463.	51.111.	43.111.	17.386.	5.392.
h	62.542	40.568	28.863	4.694	.451
h'	31.583	20.487	14.575	2.370	.228
h''	5.878	38.945	56.571	92.941	99.330
H	100.0	100.0	100.0	100.0	100.0

It is here shown that the values of h and h' cannot be neglected until the length of the pipe exceeds one thousand diameters, under the ordinary conditions of public water supplies.

In our first length of five feet, h is about ten and one-half times h'' , and h' is about five and one-half times h'' .

TABLE No. 63.

RESULTS GIVEN BY VARIOUS FORMULAS FOR FLOW OF WATER IN SMOOTH PIPES, UNDER PRESSURE, COMPARED.

DATA.—To find the velocity, given: *Head, H* = 100 feet; *Diameter, d* = 1 foot; and *Lengths, l*, respectively as follows:

AUTHORITY.	EQUATIONS.	LENGTHS.				
		5 feet.	50 feet.	100 feet.	1000 feet.	10,000 feet.
Equation (11) ..	$v = \left\{ \frac{2gH}{(1 + c) + m \frac{l}{r}} \right\}^{\frac{1}{2}}$	63.463	51.111	43.111	17.386	5.392
Chezy	$v = \left\{ \frac{ghS}{\frac{1}{2}mC} \right\}^{\frac{1}{2}}$	223.607	70.710	50.000	15.810	5.000
Du Buat	$v = \frac{88.5r^{\frac{1}{2}} - .03}{\left(\frac{l}{h}\right)^{\frac{1}{2}} - \text{hyp. log.} \left(\frac{l}{h} + 1.6\right)^{\frac{1}{2}}} - .84(r^{\frac{1}{2}} - .03)$	102.918	81.510	13.662	3.9781	
Prony (a)	$v = (9419.75ri + .00665)^{\frac{1}{2}} - .0816$	216.94	68.54	48.446	15.258	4.770
" (b)	$v = (9978.76ri + .02375)^{\frac{1}{2}} - .15412$	223.214	70.480	49.792	15.641	4.842
Eytelwein (a) ..	$v = (11703.95ri + .01698)^{\frac{1}{2}} - .1308$	241.778	76.367	53.960	16.975	5.280
" (b) ..	$v = 50 \left\{ \frac{dh}{l + 50d} \right\}^{\frac{1}{2}}$	67.40	50.00	40.82	15.427	4.985
Saint Venant ..	$v = 105.926 (ri)^{\frac{1}{2}}$	246.171	73.682	51.247	15.232	4.592
D'Aubuisson (a)	$v = (9579ri + .00813)^{\frac{1}{2}} - .0902$	218.758	69.114	48.845	15.384	4.800
" (b) ..	$v = 95.6 \sqrt{ri}$	213.761	67.589	47.804	15.114	4.780
Neville (a)	$v = \left\{ \frac{Hr}{.0234r + .0001085l} \right\}^{\frac{1}{2}}$	62.540	47.080	38.750	14.780	4.780
" (b)	$v = 140 (ri)^{\frac{1}{2}} - 11 (ri)^{\frac{1}{3}}$	294.650	90.263	63.070	18.917	5.507
Blackwell	$v = 47.913 \left\{ \frac{hd}{l} \right\}^{\frac{1}{2}}$	214.267	67.715	47.913	15.140	4.791
D'Arcy	$v = \left\{ \frac{ri}{.00007726 + \frac{.00000162}{r}} \right\}^{\frac{1}{2}}$	244.120	77.133	54.640	17.279	5.464
Leslie	$v = 100 \sqrt{ri}$	223.607	70.710	50.000	15.810	5.000
Jackson	$v = 50c (di)^{\frac{1}{2}}$	223.607	70.710	50.000	15.810	5.000
Hawksley	$v = 48.045 \left\{ \frac{dh}{l + 54d} \right\}^{\frac{1}{2}}$	62.555	47.084	38.724	14.797	4.804

In which *C* = contour of pipe, in feet; *l* = length of pipe, in feet.
c = unity for smooth pipes, and *m* = coefficient of flow.
is reduced for rough pipes. *r* = hyd. mean radius, in feet, = $\frac{d}{4}$.
d = diam. of pipe, in feet. *S* = sectional area of pipe, in square feet.
H = entire head, in feet. *i* = sine of inclination, in feet, = $\frac{h}{l}$.
h = resistance head, in feet. *v* = velocity of flow, in feet per sec.

In long pipes, sufficient velocity is converted into pressure to reduce somewhat the contraction of the jet at its entrance into the pipe. In very long pipes the effect of this contraction becomes insignificant when compared with the effect of reaction from the walls of the pipe.

283. Investigations by Du Buat, Coloumb, and Prony.—The investigations of Du Buat and Coloumb led them to the conclusion that the velocity of the fluid occasioned a resistance to flow, in addition to that arising from the wet perimeter of a channel or pipe, which is proportional to the simple velocity; and afterwards Prony, coinciding with this view, undertook the investigation of the two coefficients thus introduced into the formula of resistance to flow.

Since their new coefficient, β , applied to the simple velocity and not to the square of the velocity, as does the coefficient m , their expression, in our symbols, became

$$H - \frac{v^2}{2g} = m \frac{Cl}{S} (v^2 + \beta v); \quad (15)$$

in which

$$\left(H - \frac{v^2}{2g} = (H - h) \text{ or } h' + h'' \right)$$

284. Prony's Analysis.—Prony analyzed the results of fifty-one experiments to determine the values of m and β , including eighteen experiments by Du Buat with a tin pipe of about one inch diameter and sixty-five feet long; twenty-six experiments by Bossut with pipes of about one, one and one-quarter, and two-inch diameters, and varying in length from thirty-two to one hundred and ninety-two feet; and seven experiments by Couplet. Six of these last experiments were made with a five and one-quarter inch pipe, under a head less than two and one-quarter feet, and

one with a nineteen-inch pipe with a head of about twelve and one-half feet.

We have quoted above (§ 269) eight of the experiments by Du Buat, nine of those by Bossut, and the full seven by Couplet, and in the two first included the extremes so as to cover their entire range.

This was a limited foundation upon which to build a theory of the flow of water in pipes, nevertheless the attainments of this eminent investigator enabled him to deduce from the limited data hypotheses which were valuable contributions to hydrodynamic science.

From these experiments Prony deduced the values, as reduced to English measures, $m = .0001061473$; and $\beta = .16327$.

285. Eytelwein's Equation of Resistance to Flow.

—Eytelwein, investigating the question anew, and believing the contraction of the vein at the entrance to the pipe should not be overlooked, soon afterward modified the equation to the form,

$$H - \frac{v^2}{2gc'} = .000085434 \frac{Cl}{S} (v^2 + .2756 v), \quad (16)$$

in which c' refers to the effect of the contraction.

286. D'Aubuisson's Equation of Resistance to Flow.—D'Aubuisson, more than a half-century later, having regard more particularly to the experiments of Couplet, gave to m and β values as follows :

$$H - \frac{v^2}{2g} = .000104392 \frac{Cl}{S} (v^2 + .180449 v). \quad (17)$$

287. Weisbach's Equation of Resistance to Flow.

—Weisbach, availing himself of eleven experiments of his own with high velocities, and one by M. Gueymard, in ad-

dition to the fifty-one above referred to, proposed the following formula as coinciding better with the results of his observations :

$$h'' = \left(a + \frac{\beta}{\sqrt{v}} \right) \frac{l}{d} \frac{v^2}{2g} = \left(.014312 + \frac{.017155}{\sqrt{v}} \right) \frac{l}{d} \frac{v^2}{2g}. \quad (18)$$

This coefficient $\left(a + \frac{\beta}{\sqrt{v}} \right)$, which replaces $4m$ in our symbols, is founded upon the assumption that the resistance of friction increases at the same time with the square and with the square root of the cube of the velocity.

288. Transpositions of an Original Formula.—

That Chezy's formula has been generally accepted as one founded upon correct principles, we readily infer by its frequent adoption, transposition and modification in the writings of many philosophers and hydraulicians. Note, for instance, the second formulas (v) of Eytelwein and D'Aubuisson in the above table (No. 63), and the formulas of Beardmore, Blackwell, Downing, Hawksley, Jackson, Box, Storrow, and others, which may be resolved into this original form.

289. Unintelligent Use of Partial Formulas.—

That serious errors may arise from an unintelligent and improper use of these formulas is conspicuously apparent in the above table of results, computed upon conditions in the very midst of the range of conditions of ordinary municipal water supplies. A full knowledge of the origin of a formula is essential for its safe practical application.

A solid body falling freely in a vacuum through a height of 100 feet, acquires a rate of motion of only about 80.3 feet per second, yet some of the formulas appear to indicate a velocity of flow exceeding 200 feet per second, through five feet of pipe, under 100 feet head pressure.

290. A Formula of more General Application.—

Weisbach has suggested a more comprehensive form of expression which includes the head generating the velocity of flow and the head equivalent to the dynamic force lost at the entry of the jet into the pipe, as well as the head balancing the resistance to flow in the pipe, and therefore his equation presents the equality between the total head H , and the sum of the velocity and resistance heads equal to $h + h' + h''$.

Weisbach has also developed a portion of the values of m .

291. Value of v for Given Slopes.—We have heretofore insisted that m , as introduced into the equation, shall approximate near to its legitimate value for the given conditions. Its value for each given diameter, or hydraulic mean radius, r , depends upon the velocity of flow, and therefore upon the slope, s , generating the velocity.

To aid in the selection of m from the tables of m , page 242, we have plotted the several velocities as ordinates with given sines of slopes, i , as abscissas for such experimental data as was obtainable, and have taken the intermediate approximate values of v from their parabolic curves thus determined from the experimental data, and have arranged the following table of v ; which of course refers to the head h'' , balancing the resistance in the slope s .

TABLE No. 64.

VELOCITIES, v , FOR GIVEN SLOPES AND DIAMETERS.
FOR CLEAN IRON PIPES.

$$\left\{ v = \sqrt{2gH} \cdot \left(\frac{1}{(1 + c_r) + m \frac{l}{r}} \right)^{\frac{1}{2}} \right\} \quad \text{or} \quad v = \left(\frac{2gr_i}{m} \right)^{\frac{1}{2}}$$

SLOPE.	SINE OF SLOPE.	DIAMETERS.					
		$\frac{1}{2}$ inch. .0417 ft.	$\frac{3}{4}$ " .0625'	1" .0834'	1 $\frac{1}{2}$ " .1250'	1 $\frac{3}{4}$ " .1458'	2" .1667'
	$i = \frac{h}{l}$	Velocity. Ft. per sec.	Velocity. Ft. per sec.	Velocity. Ft. per sec.	Velocity. Ft. per sec.	Velocity. Ft. per sec.	Velocity. Ft. per sec.
I in 250	.004	1.184
I " 200	.005	1.206	1.340
I " 167	.006	1.190	1.360	1.500
I " 143	.007	1.290	1.453	1.600
I " 125	.008	1.038	1.391	1.580	1.730
I " III	.009	1.130	1.480	1.700	1.870
I " 100	.010	1.030	1.240	1.600	1.790	1.980
I " 83.3	.012	0.892	1.140	1.430	1.730	1.953	2.219
I " 71.4	.014	0.910	1.230	1.540	1.860	2.130	2.360
I " 62.5	.016	0.990	1.340	1.640	2.010	2.220	2.500
I " 55.6	.018	1.050	1.450	1.760	2.100	2.350	2.630
I " 50.0	.02	1.100	1.518	1.813	2.276	2.530	2.800
I " 33.3	.03	1.440	1.920	2.280	2.810	3.100	3.390
I " 25.0	.04	1.765	2.298	2.730	3.367	3.694	4.002
I " 20.0	.05	2.040	2.600	3.050	3.730	4.280	5.020
I " 16.6	.06	2.310	2.850	3.400	4.110	4.690	5.500
I " 14.3	.07	2.490	3.100	3.640	4.420	5.020	5.900
I " 12.5	.08	2.680	3.300	3.920	4.730	5.360	6.300
I " 11.1	.09	2.850	3.540	4.180	5.045	5.630	6.610
I " 10.0	.10	3.040	3.730	4.437	5.480	6.009	6.979
I " 8.33	.12	3.320	4.180	4.900	6.030	6.650	7.490
I " 7.14	.14	3.460	4.500	5.290	6.535	7.190	8.010
I " 6.25	.16	3.840	4.825	5.640	7.010	7.700	8.500
I " 5.55	.18	4.090	5.108	5.998	7.500	8.221	8.960
I " 5.00	.20	4.310	5.400	6.330	7.880	8.690	9.380
I " 4.00	.25	4.830	6.100	7.135	8.770	9.690	10.430
I " 3.33	.30	5.359	6.730	7.902	9.650	10.620	11.380
I " 2.50	.40	6.260	7.790	9.130	11.225	12.280	12.980
I " 2.00	.50	7.070	8.818	10.339	12.600
I " 1.66	.60	7.800	9.790	11.570
I " 1.43	.70	8.470	10.760	12.710
I " 1.25	.80	9.140
I " 1.11	.90	9.800	12.600
I " 1.00	I	10.390

TABLE No. 64—(Continued).

VELOCITIES, v , FOR GIVEN SLOPES AND DIAMETERS.
FOR CLEAN IRON PIPES.

SLOPE.	SINE OF SLOPE.	DIAMETERS.					
		3 inch. .250 ft.	4" .3333'.	6" .5'.	8" .6667'.	10" .8333'.	12" 1.0'.
	$i = \frac{h}{l}$	Velocity. Ft. per sec.	Velocity. Ft. per sec.	Velocity. Ft. per sec.	Velocity. Ft. per sec.	Velocity. Ft. per sec.	Velocity. Ft. per sec.
I in IIII	.0009	1.540
I " 1000	.0010	1.610
I " 909	.0011	1.680
I " 833	.0012	1.610	1.785
I " 769	.0013	1.692	1.880
I " 714	.0014	1.760	1.940
I " 667	.0015	1.840	2.010
I " 625	.0016	1.640	1.920	2.080
I " 588	.0017	1.680	1.990	2.148
I " 556	.0018	1.750	2.035	2.200
I " 526	.0019	1.800	2.125	2.270
I " 500	.0020	1.515	1.830	2.190	2.325
I " 455	.0022	1.600	1.930	2.320	2.470
I " 417	.0024	1.680	2.015	2.430	2.580
I " 385	.0026	1.415	1.760	2.110	2.525	2.695
I " 357	.0028	1.480	1.830	2.220	2.610	2.810
I " 333	.0030	1.284	1.530	1.920	2.315	2.695	2.925
I " 286	.0035	1.410	1.680	2.100	2.510	2.910	3.140
I " 250	.004	1.525	1.790	2.260	2.690	3.085	3.390
I " 200	.005	1.710	2.030	2.525	2.993	3.420	3.845
I " 167	.006	1.863	2.204	2.790	3.315	3.775	4.215
I " 143	.007	2.020	2.460	3.000	3.615	4.075	4.585
I " 125	.008	2.160	2.670	3.215	3.850	4.370	4.910
I " 111	.009	2.280	2.820	3.425	4.080	4.610	5.185
I " 100	.010	2.425	2.960	3.670	4.285	4.880	5.480
I " 83.3	.012	2.675	2.230	3.992	4.710	5.375	6.020
I " 71.4	.014	2.880	2.480	4.370	5.105	5.885	6.485
I " 62.5	.016	3.070	2.710	4.695	5.490	6.325	6.980
I " 55.6	.018	3.240	3.91	4.965	5.825	6.745	7.435
I " 50.0	.02	3.498	4.134	5.206	6.175	7.070	7.842
I " 33.3	.03	4.240	5.160	6.430	7.640	8.730	9.715
I " 25.0	.04	5.030	6.110	7.560	9.010	10.200	11.280
I " 20.0	.05	5.674	6.825	8.479	10.062	12.293	12.689
I " 16.6	.06	6.213	7.324	9.828	11.020
I " 14.3	.07	6.785	7.985	10.062	12.020
I " 12.5	.08	7.250	8.604	10.920
I " 11.1	.09	7.775	9.125	11.583
I " 10.0	.10	8.238	9.703	12.209
I " 8.33	.12	9.045	10.625
I " 7.14	.14	9.773	11.531
I " 6.25	.16	10.455	12.383
I " 5.55	.18	11.075
I " 5.00	.20	11.883
I " 4.00	.25	13.289
I " 3.33	.30

T A B L E N o. 64—(Continued).

VELOCITIES, v , FOR GIVEN SLOPES AND DIAMETERS.
FOR CLEAN IRON PIPES.

SLOPE.	SINE OF SLOPE.	DIAMETERS.					
		14 inch 1.1667 ft.	16'' 1.3333'	18'' 1.5'	20'' 1.6667'	24'' 2.0'	27'' 2.25'
	$i = \frac{h}{l}$	Velocity. Ft. per sec.	Velocity. Ft. per sec.	Velocity. Ft. per sec.	Velocity. Ft. per sec.	Velocity. Ft. per sec.	Velocity. Ft. per sec.
I in 2500	.0004
I " 2000	.0005	2.080
I " 1667	.0006	1.655	1.940	2.105
I " 1428	.0007	1.610	1.755	1.860	2.115	2.285
I " 1250	.0008	1.610	1.738	1.850	1.995	2.265	2.385
I " 1111	.0009	1.710	1.855	1.975	2.145	2.405	2.580
I " 1000	.0010	1.800	1.950	2.070	2.255	2.530	2.700
I " 909	.0011	1.895	2.065	2.195	2.360	2.655	2.880
I " 833	.0012	1.975	2.160	2.295	2.475	2.785	3.000
I " 769	.0013	2.040	2.275	2.395	2.575	2.910	3.155
I " 714	.0014	2.130	2.350	2.400	2.675	3.015	3.260
I " 667	.0015	2.200	2.425	2.606	2.775	3.120	3.395
I " 625	.0016	2.285	2.500	2.685	2.875	3.225	3.515
I " 588	.0017	2.375	2.590	2.775	2.970	3.366	3.625
I " 556	.0018	2.430	2.640	2.845	3.050	3.430	3.725
I " 526	.0019	2.500	2.725	2.925	3.170	3.535	3.825
I " 500	.0020	2.550	2.810	3.000	3.230	3.640	3.930
I " 455	.0022	2.700	2.950	3.187	3.400	3.835	4.135
I " 417	.0024	2.825	3.095	3.320	3.570	4.015	4.335
I " 385	.0026	2.950	3.230	3.495	3.730	4.210	4.530
I " 357	.0028	3.080	3.355	3.610	3.885	4.388	4.715
I " 333	.0030	3.200	3.490	3.755	4.020	4.535	4.905
I " 286	.0035	3.473	3.800	4.060	4.350	4.935	5.315
I " 250	.004	3.735	4.060	4.330	4.655	5.290	5.690
I " 200	.005	4.180	4.575	4.901	5.240	5.955	6.373
I " 167	.006	4.602	5.025	5.400	5.770	6.502	6.975
I " 143	.007	5.025	5.485	5.844	6.260	7.020	7.520
I " 125	.008	5.400	5.845	6.275	6.718	7.515	8.045
I " 111	.009	5.725	6.185	6.625	7.125	7.980	8.545
I " 100	.010	6.030	6.515	7.000	7.550	8.410	9.025
I " 83.3	.012	6.555	7.124	7.725	8.245	9.240	10.000
I " 71.4	.014	7.120	7.785	8.345	8.935	10.025	10.870
I " 62.5	.016	7.655	8.330	8.965	9.640	10.790	11.715
I " 55.6	.018	8.170	8.900	9.565	10.295	11.515	12.085
I " 50	.02	8.667	9.409	10.104	10.801	12.238
I " 33.3	.03	10.691	11.583	12.369	13.229
I " 25	.04	12.383	13.445

TABLE No. 64—(Continued.)

VELOCITIES, v , FOR GIVEN SLOPES AND DIAMETERS.
FOR CLEAN IRON PIPES.

SLOPE.	SINE OF SLOPE.	DIAMETERS.					
		30 inch 2.5 feet.	33" 2.75'	36" 3.0'	40" 3.3333'	44" 3.6667'	48" 4.0'
	$i = \frac{h}{l}$	Velocity. <i>Ft. per sec.</i>	Velocity. <i>Ft. per sec.</i>	Velocity. <i>Ft. per sec.</i>	Velocity. <i>Ft. per sec.</i>	Velocity. <i>Ft. per sec.</i>	Velocity. <i>Ft. per sec.</i>
I in 5000	.0002	1.457	1.590	1.719	1.829
I " 3333	.0003	1.586	1.681	1.797	1.948	2.104	2.220
I " 2500	.0004	1.831	1.962	2.060	2.255	2.420	2.620
I " 2000	.0005	2.085	2.175	2.313	2.530	2.735	2.945
I " 1667	.0006	2.235	2.355	2.550	2.800	2.980	3.200
I " 1428	.0007	2.425	2.550	2.796	3.010	3.265	3.475
I " 1250	.0008	2.617	2.755	2.950	3.225	3.510	3.725
I " 1111	.0009	2.745	2.960	3.155	3.415	3.695	3.904
I " 1000	.0010	2.895	3.156	3.320	3.605	3.890	4.150
I " 909	.0011	3.065	3.290	3.525	3.810	4.080	4.375
I " 833	.0012	3.220	3.415	3.695	3.975	4.260	4.565
I " 769	.0013	3.355	3.585	3.848	4.150	4.430	4.780
I " 714	.0014	3.500	3.703	3.995	4.305	4.625	4.936
I " 667	.0015	3.655	3.875	4.130	4.490	4.795	5.130
I " 625	.0016	3.785	4.000	4.285	4.645	4.970	5.295
I " 558	.0017	3.915	4.120	4.445	4.800	5.119	5.450
I " 556	.0018	4.006	4.245	4.595	4.935	5.255	5.620
I " 526	.0019	4.140	4.400	4.725	5.075	5.400	5.790
I " 500	.0020	4.235	4.535	4.880	5.180	5.575	5.924
I " 455	.0022	4.445	4.759	5.115	5.515	5.845	6.230
I " 417	.0024	4.650	5.000	5.340	5.785	6.095	6.500
I " 385	.0026	4.875	5.230	5.575	6.035	6.335	6.780
I " 357	.0028	5.065	5.435	5.780	6.307	6.590	7.040
I " 333	.0030	5.270	5.660	5.981	6.455	6.850	7.300
I " 286	.0035	5.695	6.090	6.500	7.000	7.385	7.990
I " 250	.004	6.080	6.493	6.907	7.495	7.920	8.425
I " 200	.005	6.835	7.260	7.765	8.375	8.845	9.497
I " 167	.006	7.495	7.980	8.480	9.205	9.784	10.415
I " 143	.007	8.080	8.645	9.220	9.935	10.585	11.307
I " 125	.008	8.635	9.245	9.875	10.610	11.360	12.250
I " 111	.009	9.215	9.800	10.515	11.230	12.150	...
I " 100	.010	9.720	10.375	11.100	11.919
I " 83.3	.012	10.780	11.449	11.720
I " 71.4	.014	11.745	12.450

TABLE No. 64—(Continued).
VELOCITIES, v , FOR GIVEN SLOPES AND DIAMETERS.
FOR CLEAN IRON PIPES.

SLOPE.	SINE OF SLOPE.	DIAMETERS.				
		54 inch 4.5 feet.	60" 5.0'.	72" 6.0'.	84" 7.0'.	96" 8.0'.
	$i = \frac{h}{l}$	Velocity. Ft. per sec.	Velocity. Ft. per sec.	Velocity. Ft. per sec.	Velocity. Ft. per sec.	Velocity. Ft. per sec.
I in 10000	.0001	1.381	1.516	1.661	1.906	2.144
I " 5000	.0002	1.993	1.945	2.039	2.719	3.033
I " 3333	.0003	2.423	2.653	2.919	3.279	3.749
I " 2500	.0004	2.837	3.007	3.395	3.779	4.352
I " 2000	.0005	3.158	3.441	3.870	4.229	4.880
I " 1667	.0006	3.490	3.785	4.300	4.600	5.320
I " 1428	.0007	3.785	4.100	4.670	4.990	5.780
I " 1250	.0008	4.000	4.395	4.950	5.400	6.185
I " 1111	.0009	4.235	4.685	5.260	5.780	6.600
I " 1000	.0010	4.550	4.939	5.580	6.110	6.972
I " 909	.0011	4.760	5.215	5.870	6.583	7.285
I " 833	.0012	4.975	5.465	6.120	6.880	7.600
I " 769	.0013	5.190	5.680	6.340	7.150	7.915
I " 714	.0014	5.400	5.935	6.630	7.475	8.250
I " 667	.0015	5.629	6.095	6.859	7.701	8.510
I " 625	.0016	5.815	6.300	7.080	8.000	8.815
I " 588	.0017	5.995	6.500	7.300	8.215	9.100
I " 556	.0018	6.140	6.685	7.500	8.490	9.360
I " 526	.0019	6.300	6.865	7.700	8.725	9.580
I " 500	.0020	6.528	7.071	7.965	9.049	9.875
I " 455	.0022	6.840	7.435	8.330	9.480	10.400
I " 417	.0024	7.135	7.770	8.715	9.880	10.890
I " 385	.0026	7.445	8.080	9.060	10.275	11.340
I " 357	.0028	7.740	8.380	9.450	10.611	11.780
I " 333	.0030	8.060	8.680	9.828	11.000	12.175
I " 286	.0035	8.735	9.370	10.615	12.550
I " 250	.004	9.300	10.060	11.344
I " 200	.005	10.425	11.304	12.680
I " 167	.006	11.470	12.440
I " 143	.007	12.450

292. Values of h and h' for Given Velocities.

In Table 65 are given the values of h and h' for given velocities, which are to be subtracted from H to compute the height of the slope generating the velocity v .

The velocity being known approximately, its corresponding m for any given diameter may be taken from the table of m , page 242, and inserted in the formula:

$$v = \sqrt{2gH} \cdot \left(\frac{1}{(1 + c_r) + m \frac{l}{r}} \right)^{\frac{1}{2}}$$

TABLE No. 65.

TABLES OF h AND h' DUE TO GIVEN VELOCITIES, h AND h' BEING
IN FEET AND v IN FEET PER SECOND.

Velocity.	h	h'	$h + h'$	Velocity.	h	h'	$h + h'$
.80	.010	.0050	.0150	4.47	.31	.1565	.4665
.98	.015	.0075	.0225	4.54	.32	.1616	.4816
1.13	.020	.0101	.0301	4.61	.33	.1666	.4966
1.27	.025	.0126	.0376	4.68	.34	.1717	.5117
1.39	.030	.0151	.0451	4.75	.35	.1767	.5267
1.50	.035	.0177	.0527	4.81	.36	.1818	.5418
1.60	.040	.0202	.0602	4.87	.37	.1868	.5568
1.70	.045	.0227	.0677	4.94	.38	.1919	.5719
1.79	.050	.0252	.0752	5.01	.39	.1969	.5869
1.88	.055	.0278	.0828	5.07	.40	.2020	.6020
1.97	.060	.0303	.0903	5.14	.41	.2070	.6170
2.04	.065	.0328	.0978	5.20	.42	.2121	.6321
2.12	.070	.0353	.1053	5.26	.43	.2172	.6472
2.20	.075	.0379	.1129	5.32	.44	.2222	.6622
2.27	.080	.0404	.1204	5.38	.45	.2272	.6772
2.34	.085	.0429	.1279	5.44	.46	.2323	.6923
2.41	.090	.0454	.1354	5.50	.47	.2373	.7073
2.47	.095	.0480	.1430	5.56	.48	.2424	.7224
2.54	.100	.0505	.1505	5.62	.49	.2474	.7374
2.60	.105	.0530	.1580	5.67	.50	.2525	.7525
2.66	.110	.0555	.1655	5.73	.51	.2575	.7675
2.72	.115	.0580	.1730	5.79	.52	.2626	.7826
2.78	.120	.0606	.1806	5.85	.53	.2676	.7976
2.84	.125	.0631	.1881	5.90	.54	.2727	.8127
2.89	.130	.0656	.1956	5.95	.55	.2777	.8277
2.95	.135	.0672	.2022	6.00	.56	.2828	.8428
3.00	.140	.0707	.2107	6.06	.57	.2878	.8578
3.05	.145	.0732	.2182	6.11	.58	.2929	.8729
3.11	.150	.0757	.2257	6.17	.59	.2979	.8879
3.16	.155	.0772	.2322	6.22	.60	.3030	.9030
3.21	.160	.0808	.2408	6.28	.61	.3080	.9180
3.26	.165	.0833	.2483	6.32	.62	.3131	.9331
3.31	.170	.0858	.2558	6.37	.63	.3181	.9481
3.36	.175	.0883	.2633	6.42	.64	.3232	.9632
3.40	.180	.0909	.2709	6.47	.65	.3282	.9782
3.45	.185	.0934	.2784	6.52	.66	.3333	.9933
3.50	.190	.0959	.2859	6.57	.67	.3383	1.0083
3.55	.195	.0984	.2934	6.61	.68	.3434	1.0234
3.59	.200	.1010	.3010	6.66	.69	.3484	1.0384
3.68	.21	.1060	.3160	6.71	.70	.3535	1.0535
3.76	.22	.1111	.3311	6.76	.71	.3585	1.0685
3.85	.23	.1161	.3461	6.81	.72	.3636	1.0836
3.93	.24	.1212	.3612	6.86	.73	.3686	1.0986
4.01	.25	.1262	.3762	6.91	.74	.3737	1.1137
4.09	.26	.1313	.3913	6.95	.75	.3787	1.1287
4.17	.27	.1363	.4063	6.99	.76	.3838	1.1438
4.25	.28	.1414	.4214	7.04	.77	.3888	1.1588
4.32	.29	.1464	.4364	7.09	.78	.3939	1.1739
4.39	.30	.1515	.4515				

TABLE No. 63—(Continued).

TABLES OF h AND h' DUE TO GIVEN VELOCITIES, h AND h' BEING IN FEET AND v IN FEET PER SECOND.

Velocity.	h	h'	$h + h'$	Velocity.	h	h'	$h + h'$
7.13	.79	.3989	1.1889	22.34	7.75	3.914	11.664
7.18	.80	.4040	1.2040	22.70	8	4.040	12.040
7.22	.81	.4090	1.2190	23.05	8.25	4.166	12.666
7.26	.82	.4141	1.2341	23.40	8.50	4.292	12.792
7.31	.83	.4191	1.2491	23.74	8.75	4.419	13.169
7.35	.84	.4242	1.2642	24.07	9	4.545	13.545
7.40	.85	.4292	1.2792	24.41	9.25	4.671	13.921
7.44	.86	.4343	1.2943	24.73	9.50	4.797	14.297
7.48	.87	.4393	1.3093	25.06	9.75	4.924	14.674
7.53	.88	.4444	1.3244	25.38	10	5.050	15.050
7.57	.89	.4494	1.3394	25.69	10.25	5.176	15.426
7.61	.90	.4545	1.3545	26.00	10.50	5.302	15.802
7.65	.91	.4595	1.3695	26.32	10.75	5.429	16.242
7.70	.92	.4646	1.3846	26.62	11	5.555	16.555
7.74	.93	.4696	1.3996	26.91	11.25	5.681	16.931
7.78	.94	.4747	1.4147	27.21	11.50	5.807	17.307
7.82	.95	.4797	1.4297	27.51	11.75	5.934	17.684
7.86	.96	.4848	1.4448	27.8	12	6.060	18.060
7.90	.97	.4898	1.4598	28.4	12.5	6.186	18.686
7.94	.98	.4949	1.4749	28.9	13	6.565	19.565
7.98	.99	.4999	1.4899	29.5	13.5	6.817	20.317
8.03	1	.505	1.505	30.0	14	7.070	21.070
8.97	1.25	.631	1.881	30.5	14.5	7.322	21.822
9.83	1.50	.757	2.257	31.1	15	7.575	22.575
10.60	1.75	.884	2.634	31.6	15.5	7.827	23.327
11.4	2	1.010	3.010	32.1	16	8.080	24.080
11.35	2.25	1.136	3.386	32.6	16.5	8.332	24.832
12.6	2.50	1.362	3.862	33.1	17	8.585	25.585
13.30	2.75	1.389	4.139	33.6	17.5	8.837	26.337
13.9	3	1.515	4.515	34.0	18	9.090	27.090
14.47	3.25	1.641	5.891	34.5	18.5	9.342	27.842
15.0	3.50	1.767	5.267	35.0	19	9.595	28.595
15.54	3.75	1.894	5.644	35.4	19.5	9.847	29.347
16.05	4	2.020	6.020	35.9	20	10.100	30.100
16.54	4.25	2.146	6.396	36.8	21	10.352	31.352
17.02	4.50	2.272	6.772	37.6	22	11.110	33.110
17.49	4.75	2.399	7.149	38.5	23	11.615	34.615
17.94	5	2.525	7.525	39.3	24	12.120	36.120
18.39	5.25	2.651	7.901	40.1	25	12.625	37.625
18.82	5.50	2.777	8.277	40.9	26	13.130	39.130
19.24	5.75	2.904	8.654	41.7	27	13.635	40.635
19.66	6	3.030	9.030	42.5	28	14.140	42.140
20.06	6.25	3.156	9.406	43.2	29	14.645	43.645
20.46	6.50	3.282	9.782	43.9	30	15.150	45.150
20.85	6.75	3.409	10.159	44.4	35	17.675	52.675
21.23	7	3.535	10.535	50.7	40	20.200	60.200
21.61	7.25	3.661	10.911	53.8	45	22.725	67.725
21.98	7.50	3.787	11.287	56.7	50	25.250	75.250

293. Classified Equations for Velocity, Head, Volume, and Diameter.—The coefficients of flow for the given slopes and diameters being determined, they, with the coefficients of resistance of entry for different forms of entrance, may be introduced into the classified equations for velocity, and their resolutions for head, volume, and diameter; when the equations will become,

$$v = \left\{ \begin{array}{l} \left\{ \frac{2gH}{1.054 + m \frac{l}{r}} \right\}^{\frac{1}{2}} \text{ for pipes with well-rounded entrances.} \quad (a) \\ \left\{ \frac{2gH}{1.505 + m \frac{l}{r}} \right\}^{\frac{1}{2}} \text{ for pipes with square-edged flush entrances.} \quad (b) \\ \left\{ \frac{2gH}{1.956 + m \frac{l}{r}} \right\}^{\frac{1}{2}} \text{ for pipes with square-edged entrances projecting into the reservoir.} \quad (c) \end{array} \right\} \quad (19)$$

$$H = \left\{ \begin{array}{l} \left(1.054 + m \frac{l}{r} \right) \frac{v^2}{2g} \quad \cdot \quad \cdot \quad \cdot \quad \cdot \quad (a) \\ \left(1.505 + m \frac{l}{r} \right) \frac{v^2}{2g} \quad \cdot \quad \cdot \quad \cdot \quad \cdot \quad (b) \\ \left(1.956 + m \frac{l}{r} \right) \frac{v^2}{2g} \quad \cdot \quad \cdot \quad \cdot \quad \cdot \quad (c) \end{array} \right\} \quad (20)$$

$$q = \left\{ \begin{array}{l} 6.303 \left\{ \frac{Hd^5}{1.054d + 4ml} \right\}^{\frac{1}{2}} \quad \cdot \quad \cdot \quad \cdot \quad (a) \\ 6.303 \left\{ \frac{Hd^5}{1.505d + 4ml} \right\}^{\frac{1}{2}} \quad \cdot \quad \cdot \quad \cdot \quad (b) \\ 6.303 \left\{ \frac{Hd^5}{1.956d + 4ml} \right\}^{\frac{1}{2}} \quad \cdot \quad \cdot \quad \cdot \quad (c) \end{array} \right\} \quad (21)$$

$$d = \left\{ \begin{array}{l} .4788 \left\{ 1.054d + 4ml \frac{q^2}{H} \right\}^{\frac{1}{2}} \quad \cdot \quad \cdot \quad \cdot \quad (a) \\ .4788 \left\{ 1.505d + 4ml \frac{q^2}{H} \right\}^{\frac{1}{2}} \quad \cdot \quad \cdot \quad \cdot \quad (b) \\ .4788 \left\{ 1.956d + 4ml \frac{q^2}{H} \right\}^{\frac{1}{2}} \quad \cdot \quad \cdot \quad \cdot \quad (c) \end{array} \right\} \quad (22)$$

294. Coefficients of Entrance of Jet.—Other values of c_r , for other conditions of pipe entrance, or other coefficients of velocity c_v , may be taken from, or interpolated in the following table, computed from the formulas,

$$c_r = \frac{1}{c_v^2} - 1; \quad \text{and} \quad c_v = \left(\frac{1}{c_r + 1} \right)^{\frac{1}{2}}.$$

TABLE NO. 66.

VALUES OF c_v AND c FOR TUBES.

c_v or c_r ..	.980	.974	.950	.925	.900	.875	.850	.825	.815	.800	.750	.715	.700
c_r041	.054	.109	.169	.235	.306	.383	.469	.505	.563	.778	.956	1.041
$1 + c_r$...	1.041	1.054	1.109	1.169	1.235	1.306	1.383	1.469	1.505	1.563	1.778	1.956	2.041

295. Mean Coefficients for Smooth, Rough, and Foul Pipes.—In ordinary approximate calculations for long pipes, it is often convenient to select a mean coefficient for medium diameters and velocities, and insert it in a fundamental formula as a constant. In such case we may select, say, for clean and smooth iron pipes, .00644; for rough or slightly tuberculated pipes, .0082; and for very rough or very foul pipes, .012.

These coefficients are applicable more particularly (witness table No. 61) to pipes of about five inches diameter with a velocity of flow of about three feet per second, and to lengths exceeding one thousand diameters.

$$\text{Since } \sqrt{\frac{2gr_i}{m}} = \left\{ 2g \times \frac{1}{m} \times \frac{h''}{l} \times \frac{d}{4} \right\}^{\frac{1}{2}},$$

we have

$$v = \left\{ \frac{2g}{4m} \times \frac{h''d}{l} \right\}^{\frac{1}{2}}.$$

We may now unite the constant $2g = 64.4$ and our assumed constant coefficients, and substitute their algebraic equivalents in the equations :

$$(a) \dots \frac{2g}{4m} = \frac{64.4}{.02576} = 2500.$$

$$(b) \dots \frac{2g}{4m} = \frac{64.4}{.0328} = 1963.4146.$$

$$(c) \dots \frac{2g}{4m} = \frac{64.4}{.048} = 1341.6666.$$

The equations will in this case become :

$$v = \left\{ \begin{array}{l} \left\{ 2500 \frac{h''d}{l} \right\}^{\frac{1}{2}} = 50 \left\{ \frac{h''d}{l} \right\}^{\frac{1}{2}} \text{ for clean pipes. } (a) \\ \left\{ 1963.4146 \frac{h''d}{l} \right\}^{\frac{1}{2}} = 44.31 \left\{ \frac{h''d}{l} \right\}^{\frac{1}{2}} \text{ for slightly tuber-} \\ \qquad \qquad \qquad \qquad \qquad \qquad \qquad \qquad \qquad \qquad \qquad \qquad \text{culated pipes. } (b) \\ \left\{ 1341.6666 \frac{h''d}{l} \right\}^{\frac{1}{2}} = 36.63 \left\{ \frac{h''d}{l} \right\}^{\frac{1}{2}} \text{ for very foul pipes. } (c) \end{array} \right.$$

296. Mean Equations for Smooth, Rough, and Foul Pipes.—From these expressions of *velocity*, in long, full pipes, the equations for *head*, *length*, and *diameter* may be deduced, thus :

$$v = \left\{ \begin{array}{l} 50 \left\{ \frac{h''d}{l} \right\}^{\frac{1}{2}} \text{ for clean pipes. } \quad \quad \quad (a) \\ 44.31 \left\{ \frac{h''d}{l} \right\}^{\frac{1}{2}} \text{ for slightly rough pipes. } \quad (b) \\ 36.63 \left\{ \frac{h''d}{l} \right\}^{\frac{1}{2}} \text{ for very rough pipes. } \quad (c) \end{array} \right\} (23)$$

$$h'' = \left\{ \begin{array}{l} .0004 \frac{lv^2}{d} \quad \cdot \quad \cdot \quad \cdot \quad \cdot \quad (a) \\ .000508 \frac{lv^2}{d} \quad \cdot \quad \cdot \quad \cdot \quad \cdot \quad (b) \\ .000745 \frac{lv^2}{d} \quad \cdot \quad \cdot \quad \cdot \quad \cdot \quad (c) \end{array} \right\} (24)$$

$$l = \left\{ \begin{array}{llll} 2500 & \frac{dh''}{v^2} & \cdot & \cdot & \cdot & \cdot & (a) \\ 1963.4146 & \frac{dh''}{v^2} & \cdot & \cdot & \cdot & \cdot & (b) \\ 1341.6666 & \frac{dh''}{v^2} & \cdot & \cdot & \cdot & \cdot & (c) \end{array} \right\} \quad (25)$$

$$d = \left\{ \begin{array}{llll} .0004 & \frac{lv^2}{h''} & \cdot & \cdot & \cdot & \cdot & (a) \\ .000508 & \frac{lv^2}{h''} & \cdot & \cdot & \cdot & \cdot & (b) \\ .000745 & \frac{lv^2}{h''} & \cdot & \cdot & \cdot & \cdot & (c) \end{array} \right\} \quad (26)$$

In which, v = velocity of flow, in feet, per second ;
 h'' = head in slope, or mean gradient, in feet ;
 l = length of pipe, in feet ;
 d = internal diameter of pipe, in feet.

It is sometimes convenient to express the volume of flow per second in a term of quantity, q , rather than in a term of velocity.

Since $v = \frac{q}{S}$, therefore,

$$q = Sv = 50 S \left\{ \frac{h''d}{l} \right\}^{\frac{1}{2}} = 39.27 \left\{ \frac{h''d^5}{l} \right\}^{\frac{1}{2}}$$

The equations, in terms of quantity (q), in cubic feet per second, will then take the following forms :

$$q = \left\{ \begin{array}{ll} 39.27 & \left\{ \frac{hd^5}{l} \right\}^{\frac{1}{2}} \text{ for clean pipes . . . (a)} \\ 34.80 & \left\{ \frac{hd^5}{l} \right\}^{\frac{1}{2}} \text{ for slightly rough pipes (b)} \\ 28.77 & \left\{ \frac{hd^5}{l} \right\}^{\frac{1}{2}} \text{ for very rough pipes . (c)} \end{array} \right\} \quad (27)$$

$$h'' = \left\{ \begin{array}{ll} .0006484 & \frac{lq^2}{d^5} \quad \cdot \quad \cdot \quad \cdot \quad \cdot \quad (a) \\ .0008257 & \frac{lq^2}{d^5} \quad \cdot \quad \cdot \quad \cdot \quad \cdot \quad (b) \\ .001208 & \frac{lq^2}{d^5} \quad \cdot \quad \cdot \quad \cdot \quad \cdot \quad (c) \end{array} \right\} \quad (28)$$

$$l = \left\{ \begin{array}{ll} .00064845 & \frac{h'' d^5}{q^2} \quad \cdot \quad \cdot \quad \cdot \quad \cdot \quad (a) \\ .0008257 & \frac{h'' d^5}{q^2} \quad \cdot \quad \cdot \quad \cdot \quad \cdot \quad (b) \\ .001208 & \frac{h'' d^5}{q^2} \quad \cdot \quad \cdot \quad \cdot \quad \cdot \quad (c) \end{array} \right\} \quad (29)$$

$$d = \left\{ \begin{array}{ll} .23034 & \left\{ \frac{lq^2}{h''} \right\}^{\frac{1}{5}} \quad \cdot \quad \cdot \quad \cdot \quad \cdot \quad (a) \\ .24174 & \left\{ \frac{lq^2}{h''} \right\}^{\frac{1}{5}} \quad \cdot \quad \cdot \quad \cdot \quad \cdot \quad (b) \\ .2609 & \left\{ \frac{lq^2}{h''} \right\}^{\frac{1}{5}} \quad \cdot \quad \cdot \quad \cdot \quad \cdot \quad (c) \end{array} \right\} \quad (30)$$

In which, q = volume of flow, in cubic feet per second ;
 h'' = head in slope, or mean gradient, in feet ;
 l = length of pipe, in feet ;
 d = internal diameter of pipe, in feet.

297. Modification of a Fundamental Equation of Velocity.—The following expressions for velocity, containing the *assumed* constant coefficient of flow .00644, are equivalent to each other :

$$v = \left\{ \frac{2gri}{m} \right\}^{\frac{1}{2}} = 50 \left\{ \frac{h'' d}{l} \right\}^{\frac{1}{2}} = 100 \sqrt{ri}.$$

They are sometimes modified by another coefficient, thus :

$$v = c'. \left\{ \frac{2gri}{m} \right\}^{\frac{1}{2}} = 50 c' \left\{ \frac{h'' d}{l} \right\}^{\frac{1}{2}} = 100 c' \sqrt{ri}, \quad (31)$$

to make them conform more nearly to experiment for certain classes of conditions.

This coefficient (c') equals unity ($c' = 1$) in cases when .00644 is the proper coefficient of flow to embody in the fundamental formula; is greater than unity ($c' > 1$) when the principal coefficient should be less than .00644, and less than unity ($c' < 1$) when the principal coefficient should exceed .00644. Generally, with medium velocities of say two and one-half to three feet per second, this coefficient, c' , will exceed unity for long clean pipes exceeding five inches diameter, and be less than unity for pipes of less than five inches diameter.

298. Values of c' .—When the legitimate coefficient, m , is replaced by the assumed constant coefficient .00644, then approximately,

$$\left\{ \frac{2g}{.00644} \right\}^{\frac{1}{2}} : \left\{ \frac{2g}{m} \right\}^{\frac{1}{2}} :: 1 : c',$$

therefore,

$$c' = \left\{ \frac{2g \div m}{2g \div .00644} \right\}^{\frac{1}{2}} = \left\{ \frac{2g}{10000 m} \right\}^{\frac{1}{2}} \quad (32)$$

With a given velocity of flow of say three feet per second, in pipes exceeding one thousand diameters in length, the several values of c' for different diameters would be approximately as follows:

TABLE No. 66a.
SUB-COEFFICIENTS OF FLOW (c') IN PIPES.

Diameter.	c' .	Diameter.	c' .	Diameter.	c' .
$\frac{1}{2}$ inch.	.930	6 inches.	1.015	24 inches.	1.150
$\frac{3}{4}$ "	.936	8 "	1.031	27 "	1.170
1 "	.942	10 "	1.050	30 "	1.195
$1\frac{1}{2}$ "	.950	12 "	1.060	33 "	1.207
$1\frac{3}{4}$ "	.960	14 "	1.080	36 "	1.225
2 "	.970	16 "	1.095	40 "	1.245
3 "	.980	18 "	1.110	44 "	1.287
4 "	.995	20 "	1.125	48 "	1.308

These values of c' decrease as the velocity of flow decreases from three feet per second, and are approximately correct for higher velocities up to ten feet per second.

BENDS AND BRANCHES

299. Bends.—The experiments with bends, angles, and contractions in pipes, so far as recorded, have been with very small pipes, and the deductions therefrom are of uncertain value when applied to the ordinary mains and distribution pipes of public water supplies.

Our pipes should be so proportioned that the velocity of flow, at an extreme, need not exceed ten feet per second. Our bends should have a radius, at axis, equal at least to four diameters.

Under such conditions, the loss of head at a single bend will not exceed about one-tenth the height to which the velocity is due (not including height balancing resistance of pipe-wall).

In such case, we may for an approximation take,*

$$v = \left\{ \frac{2gH}{\left(\frac{(1 + c_r) + 4m \frac{l}{d}}{.9} \right)} \right\}^{\frac{1}{2}} \quad (33)$$

$$H = \left\{ \frac{(1 + c_r) + 4m \frac{l}{d}}{.9} \right\} \times \frac{v^2}{2g} \quad (34)$$

According to this equation, if a pipe is 1 foot diameter, 1000 feet long, and flowing with free end under 100 feet head, the loss at one 90° bend, whose axial radius of curvature equals 4 diameters, will be .47 feet of head. If there are two bends, the total head remaining constant, the loss

* The mean value of $(1 + c_r)$ for short pipes is 1.505.

at both will not be double this amount, for the velocity through the first will be reduced by the resistance in the second, and therefore the resistance in the first will be reduced proportionally with the square of the reduction of the velocity; and a similar proportional reduction of resistance will take place in the first and second bends when a third is added.

Let v be the velocity due to the given head and length of pipe without a bend, and v_1 the velocity after the bend is inserted, then the height of head lost, h_b , in consequence of the bend, is

$$h_b = \frac{(v - v_1)^2}{2g}$$

and $H - h_b$ is the effective remaining head.

After computing the new value of H beyond the first bend, we may substitute that in the equation, *to find the new value* double the ~~subdivisor 0~~, and proceed to deduce the value of H beyond the second bend, etc.

For larger pipes, or for larger radius of curvature, or reduced velocity, the value of the subdivisor may rise to .94 or .96, or even near to ~~zero~~ *unity*.

When pipes exceed one thousand diameters in length, the term $(1 + c_r)$ may be neglected, and the equations assume the more simple forms,

$$v = \left\{ \frac{2gh''ri}{1.111m} \right\}^{\frac{1}{2}} \quad (35)$$

$$h'' = \frac{1.111mv^2}{2gri} \quad (36)$$

In which v = the rate of flow, in feet per second.

h = the head balancing frictional resistance of pipe-wall, in feet.

i = the sine of inclination = $\frac{\text{head}}{\text{length}}$.

r = the hydraulic mean radius = $\frac{\text{section}}{\text{contour}}$.

m = a coefficient (*vide* table of m , page 242).

$2g = 64.4$.

The experiments by Du Buat, Venturi, and other of the early experimentalists, with pipes varying from one-half to two inches diameter, and more recent experiments by Weisbach, have been fully and ably discussed by the latter, in "Mechanics of Engineering" and elsewhere.

Weisbach's formula for *additional* height of head, h_b , necessary to overcome the resistance of *one* bend, is

$$h_b = z \frac{\phi}{180^\circ} \times \frac{v^2}{2g}, \quad (37)$$

in which z is a coefficient of resistance, ϕ the arc of the bend in degrees, and h_b the additional head required.

The value of z he deduces by an empirical formula :

$$z = .131 + 1.847 \left(\frac{r}{R} \right)^{\frac{7}{2}},$$

in which r is the radius or semi-diameter of the pipe, and R the axial radius of curvature of the bend.

For given ratios of r to R , z has the following values, for pipes with circular cross-sections.

TABLE NO. 67.
COEFFICIENTS OF RESISTANCE IN BENDS.

$\frac{r}{R}$.1	.15	.2	.25	.3	.35	.4	.45	.5	.55
z	.131	.133	.138	.145	.158	.178	.206	.244	.294	.350
$\frac{r}{R}$.6	.65	.7	.75	.8	.85	.9	.95	1
z	.440	.540	.661	.806	.977	1.177	1.408	1.674	1.978

300. Branches.—In branches, the sums of the resistances due to the deflections of the moving particles, the contractions of sections by centrifugal force, and the contractions near square edges, if there are such, will for each given velocity vary inversely as the diameters of the branches.

Until reliable data for other than small pipe branches is supplied, we may assume in approximate preliminary estimates of head required, when the velocity of flow, under pressure, is ten feet per second, a reduction of that portion of the head to which the velocity is due ($= \frac{v^2}{2g}$) at a right-angled branch, equal to about fifty per cent. in branches of three to six inches diameter and thirty to forty per cent. in larger branches.

The equations then take the following form :

$$v = \left\{ \frac{2gH}{(1 + c_r) + \left(4m \frac{l}{d}\right)} \cdot .60 \right\}^{\frac{1}{2}} \quad (38)$$

$$H = \frac{(1 + c_r) + \left(4m \frac{l}{d}\right)}{.60} \times \frac{v^2}{2g} \quad (39)$$

The value of the subdivisor will be changed according to the special conditions of the given case, and the effects of a series of branches will be similar to those above described for a series of bends, but enhanced in degree.

For long pipes, equivalent equations will be,

$$v = \left\{ \frac{2ghri}{1.666m} \right\}^{\frac{1}{2}} \quad (40)$$

$$h'' = \frac{1.666mv^2}{2gri} \quad (41)$$

301. How to Economize Head.—The losses of head and of energy due to frictions of pipe-wall and to resistances of angles, contractions, etc., increase with the square of the velocity, and they occasionally consume so much of the head that a very small fraction of the entire head only remains to generate the final velocity of flow.

The losses, other than those due to the walls of the pipes, originate chiefly about the *square edges* of the pipes, orifices, and valves, where contractions and their resulting eddies are produced, or are due to the centrifugal force of the particles in angles and bends.

These losses about the edges may be modified materially, even near to zero, by rounding all entrances to the form of their *venâ contractâ*, and by joining all pipes of lesser diameter to the greater by acutely converging or gently curved reducers (Fig. 102), so that *the solidity and symmetrical section* of the column of water shall not be disturbed, and *so that all changes of velocity shall be gradual and without agitation among the fluid particles.*

It is of the utmost importance, when head and energy are to be economized, that the general *onward motion* of the particles of the jet be maintained, since wherever a sudden contraction occurs an eddy is produced, and wherever currents of different velocities and directions intermingle an agitation results, both of which divert a portion of the forward energy of the particles to the right and left, and convert it into pressure against the walls of the pipe, from whence so much reaction as is across the pipe is void of useful effect, and the energy of the jet to a like extent neutralized, and so much as is back into the approaching column is a twofold consumption of dynamic force.

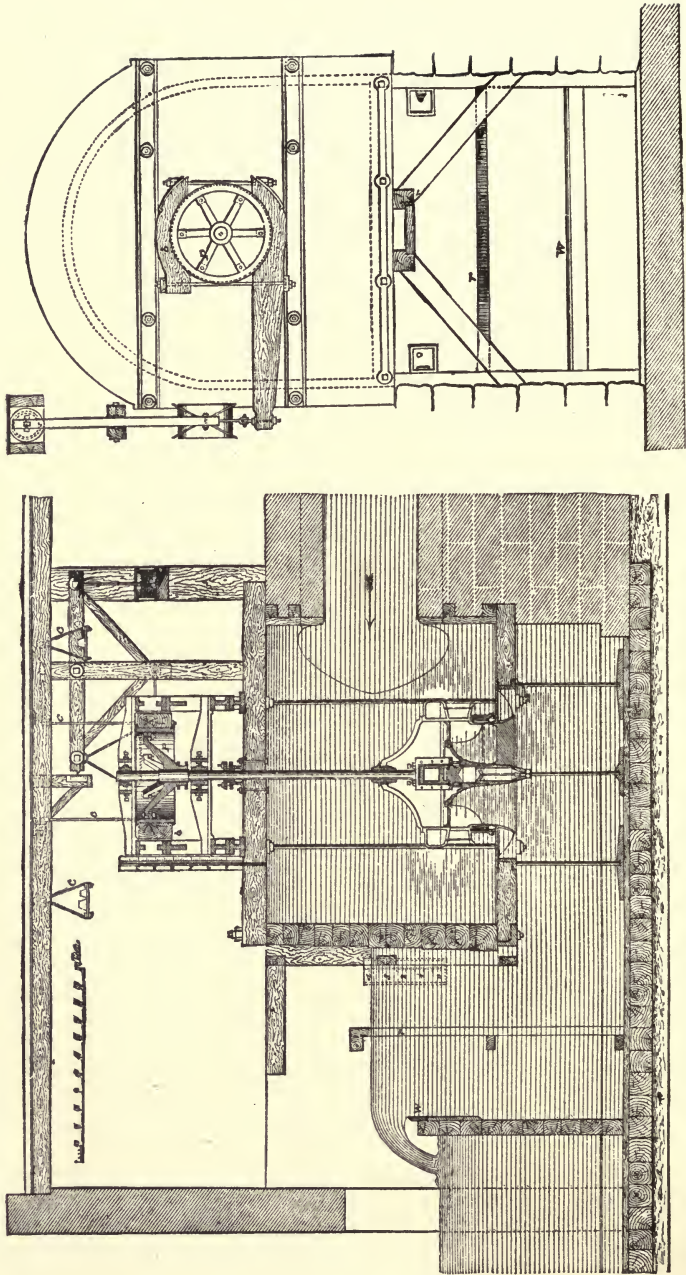

WEIR, FOR A TURBINE TEST AT LOWELL, BY JAS. B. FRANCIS, C. E.

CHAPTER XIV.

MEASURING WEIRS, AND WEIR GAUGING.

302. Gauged Volumes of Flow.—A partially submerged measuring orifice or notch in one of the upright sides of a water tank, or a horizontal measuring crest with vertical shoulders, in a barrier across a stream, equivalent to a notch, is termed a *weir*.

Weirs, as well as submerged orifices (§ 206) are used for gauging the flow of water, and in their approved forms give opportunity to apply the constant force and acceleration of gravity, acting upon the water that falls over the weir, to aid in determining the volume of its flow.

The volume of flow, Q , equals the product of the section of the jet upon the weir, S , into its mean velocity, V .

$$Q = SV. \quad (1)$$

303. Form of Weir.—For convenience in practical construction and use, hydraulicians usually form their measuring weirs with horizontal crests, CD , and vertical ends AC and BD , Fig. 41.

FIG. 40.

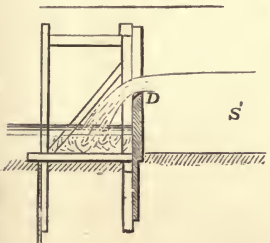
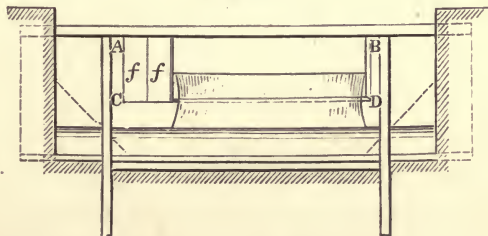

FIG. 41.



The theory of flow over weirs of this description is more accurately established by numerous experimental and positive measurements, than for any other form of notch.

The head of water upon rectangular weirs is measured from the crest CD of the weir to the surface of still water, a short distance above the weir, instead of from the centre of pressure or centre of gravity (§ 206) of the aperture, as in the case of submerged orifices.

The weir is placed at right angles to the stream, with its upstream face in a vertical plane.

The crest and vertical shoulders of the weir are chamfered so as to flare outward on the discharge side at an angle not less than thirty degrees. The thin crest and ends receiving the current must be truly horizontal and vertical, and truly at right angles to the upper plane of the

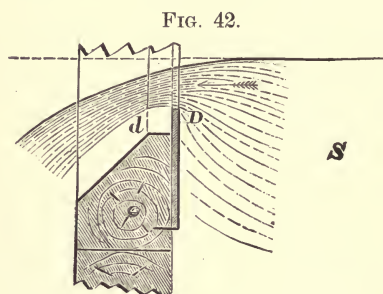

weir, and sharp-edged, so as to give a contracted jet analogous to that flowing through thin, square-edged plate.

The edges are commonly formed of a jointed and chamfered casting, or of a jointed plate not exceeding

one-tenth inch thickness, as shown in Fig. 42.

304. Dimensions. — The dimensions of the notch should be ample to carry the entire stream, and yet not so long that the depth of water upon a sharp crest shall be less than five inches, and if contraction is obtained at the upright ends, the section of the jet in the notch should not exceed one-fifth the section of the approaching stream, lest the stream approach the weir with an acquired velocity that will appreciate the natural volume of flow through the notch.

305. Stability.—Care is to be taken to make the foundation of the weir firm, the bracing substantial, and the planking rigid, so there shall be no vibration of the framework or crest, and its sheet piling is to go deep, and well into the banks on each side, when set in a stream, so that there shall be no escape of water under or around it, and a firm apron is to be provided to receive the falling water and to prevent undermining.

306. Varying Length.—Upon mountain streams, it is frequently necessary to provide for increasing or shortening the length of the weir, so that due proportions of notch to volume may be maintained. This may be accomplished by the use of vertical stop-planks with flared edges, placed at one or both ends of the weir, as at *ff*, Fig. 41.

Sometimes it is necessary to make the notch of the entire width of the stream, when there will be crest contraction only, and no end contractions, in which case partitions *E* (Fig. 44) should be placed against the upper side of the

FIG. 43.

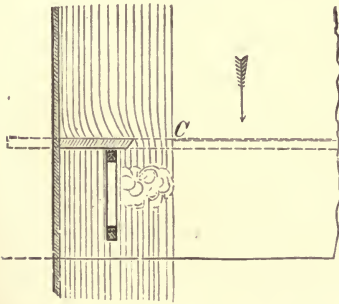
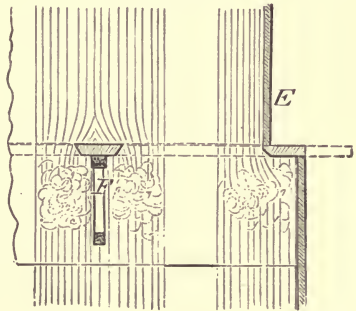

FIG. 44.



weir flush with its shoulders and at right angles to its plane. On other occasions the weir may be so long as to require intermediate posts, *F* (Fig. 44), in its framework, when intermediate contractions, one to each side of a post, will be obtained, in additions to the crest and end contrac-

tions; each of which exerts an important diminishing influence upon the volume of flow.

307. End Contractions.—A *short weir* may be defined, one which is appreciably affected by end contractions throughout its entire length; practically, when the length of unbroken opening is less than about four times the depth of water flowing over.

The end contractions affect a nearly constant length at each end, for each given depth, on long weirs, and such length increases with the depth of water upon the weir.

To obtain perfect end contractions, the distance from the vertical shoulder to the side of the channel should not be less than double the depth of the water upon the weir.

If there is no end contraction, the volume for any given depth is proportional to the entire length of the weir.

The flow, for a given length, on long weirs, or on weirs without end contractions, is proportional to a power of the depth on the weir.

308. Crest Contractions.—To obtain perfect crest contractions, the depth of water above the weir should not be less than about double the depth upon the weir, especially when the depth flowing over is less than one foot; and the clear fall below the crest to the surface of tail water should be sufficient to maintain a perfect circulation of air in the crest contraction, d (Fig. 42), under the jet, all along the crest. Such supplies of air are to be provided for at ends, and at central posts, F (Fig. 44), since a vacuum under the jet would defeat the application of the ordinary formula.

309. Theory of Flow over a Weir.—To illustrate the deduced theory of flow through rectangular notches, we will first consider a case independent of contraction:

FIG. 45.

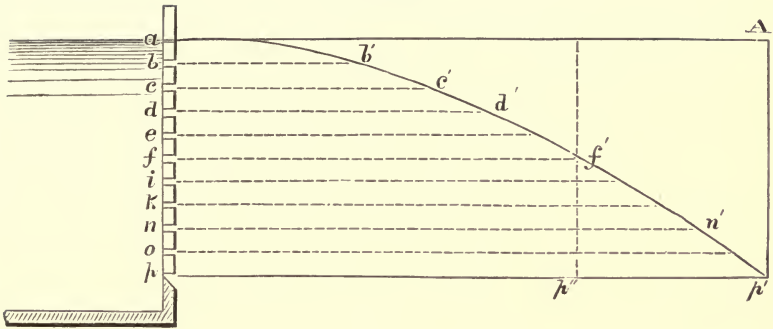

Let a, b, c, d, e, f , etc. (Fig. 45), be orifices in the side of a reservoir, at depths below the water surface, respectively of 1, 2, 3, 4, 5, 6, etc., feet.

Then the velocity of issue of jet from each orifice will be

$$V = \sqrt{2gH},$$

according to its depth, H , below the surface, viz. :

For orifice	b ,	$V = \sqrt{2g1} = 8.03$	feet per second.
“ “	c ,	$V = \sqrt{2g2} = 11.40$	“ “ “
“ “	d ,	$V = \sqrt{2g3} = 13.90$	“ “ “
“ “	e ,	$V = \sqrt{2g4} = 16.00$	“ “ “
“ “	f ,	$V = \sqrt{2g5} = 17.90$	“ “ “
“ “	i ,	$V = \sqrt{2g6} = 19.70$	“ “ “
“ “	k ,	$V = \sqrt{2g7} = 21.20$	“ “ “
“ “	n ,	$V = \sqrt{2g8} = 22.70$	“ “ “
“ “	o ,	$V = \sqrt{2g9} = 24.10$	“ “ “
“ “	p ,	$V = \sqrt{2g10} = 25.40$	“ “ “

Plot each of these depth, a, b, c , etc., to scale upon the same vertical line as abscisses and their corresponding velocities of issue, bb', cc', dd' , etc., horizontally to the same

scale as ordinates; then the extremities of the horizontal lines will touch a parabolic line, a, b', d', p' , whose vertex is at a , abscissa is ap , ordinates are bb', cc', pp' , etc., and whose parameter equals $2g$.

Suppose now the lintels separating the orifices are infinitely thin, then the volume issuing per second from each orifice will equal a prism, whose length and height equals that of the orifice, and whose mean projection is equal to its ordinate, bb', cc', dd' , etc., or equals in feet, the feet per second of velocity of issue from the orifice.

Again, suppose the partitions to be entirely removed and the fluid veins to be infinitely thin and infinite in number as respects height, then the velocities of the veins plotted to scale, will touch, as before, the parabolic line $ab'd'p'$, and the volume of issue per second will equal a prism whose end area equals the notch ap , and whose area of projection equals the area of the parabolic segment, $app'd'a$.

According to well known properties of the parabola, the segment $app'd'a$ is equal to two-thirds its circumscribing parallelogram $Aapp'$.

Let l be the length of the notch, H the height = ap , and $\sqrt{2gH}$ the length of the segment = pp' ; then the area of the circumscribing parallelogram equals $H \times \sqrt{2gH}$ and the area of the segment equals $H \times \frac{2}{3} \sqrt{2gH}$ and the volume of issue $Q = l \times H \times \frac{2}{3} \sqrt{2gH}$. (2)

Let V be the velocity of the film of mean velocity. Since the volume of the segmental prism $app'd'a$ equals two thirds of the paralleliped Ap of equal height, length, and projection, it follows that the volume of the segment equals the volume of a paralleliped of equal height and length and of $\frac{2}{3}$ the projection = pp'' , and the mean velocity of issue, $V = pp'' = \frac{2}{3} \sqrt{2gH}$.

The volume $Q = l \times H \times V = l \times H \times \frac{2}{3} \sqrt{2gH}$.

If the crest of the weir is raised to f , then let the height af be h , and the velocity of issue of the film at the crest f will be $\sqrt{2gh}$, and the volume of issue q from the notch af will be, $q = \frac{2}{3}l \times h \times \sqrt{h} \times \sqrt{2g}$.

If the volume q of this segmental prism $aff'b'a$, be subtracted from the volume Q of the segmental prism $app'd'a$, the remainder will equal the volume of the prism $fpp'f' = Q - q = (\frac{2}{3}l \times H \times \sqrt{H} \times \sqrt{2g}) - (\frac{2}{3}l \times h \times \sqrt{h} \times \sqrt{2g}) = \frac{2}{3}l \sqrt{2g} (\overline{H\sqrt{H}} - \overline{h\sqrt{h}})$. (3)

310. Formulas for Flow without and with Contractions. — The formula (2), $Q = l \times H \times \frac{2}{3} \sqrt{2g} \times \sqrt{H}$ may take the form $Q = \sqrt{2g} \times l \times \frac{2}{3} H^{\frac{3}{2}}$. (4)

Taking into consideration the complete contraction in a rectangular weir, we observe first, that in addition to the crest and end contractions, the surface of the stream, Fig. 42, begins to lower at a short distance above the weir, and the jet assumes a downward curve over the weir.

Experiments demonstrate that the measurements are facilitated, both in accuracy of observations and in ease of calculations, by taking the height of water upon the weir to the true surface level a short distance above the weir, instead of to the actual surface immediately over the crest. In such case the top contraction has no separate coefficient in the formula of volume.

Experiments demonstrate also, that a perfect end contraction, when depths upon the weir are between three and twenty-four inches, and length not less than three times the given depth, will reduce the effective length of the weir a mean amount, approximately equal to one-tenth of the depth from still water surface to crest.

If H is this depth from surface to crest, and l the full length of the weir, and l' the effective length of the weir, then one end contraction makes $l' = (l - 0.1H)$; and two

end contractions make $l = (l - 0.2H)$; and any number, n , of end contractions make $l = (l - 0.1nH)$.

The reduction of volume by the crest contraction is compensated for by a coefficient m introduced in the formula for theoretical volume, as above deduced. This coefficient (m) is to be determined for the several relative depths and lengths by experiment.

If we insert the factors relating to end and crest contractions, the formula for volume becomes :

$$Q = \frac{2}{3}m \times \sqrt{2g} \times (l - 0.1nH)H^{\frac{3}{2}}. \quad (5)$$

The factors $\frac{2}{3}$ and $\sqrt{2g}$ are constants, and for *approximate* calculations within limits of 3 to 24 inches depths upon the weir, m may be taken as constant.

Let C represent the product of these three factors, then $C = \frac{2}{3}m \times \sqrt{2g}$.

The admirable experiments with weirs* upon a great scale, which were conducted by James B. Francis, C. E., with the aid of the most perfect mechanical appliances, in a most thorough and careful manner, give to C a mean value of 3.33, and we have $3.33 = \frac{2}{3}m \times \sqrt{2g}$.

Transposing and assigning to $\sqrt{2g}$ its numerical value, we have,

$$m = \frac{3.33}{\frac{2}{3} \times 8.025} = \frac{3.33}{5.35} = .622 \text{ as a mean coefficient.}$$

The formula for volume of flow may take the following forms :

$$Q = \frac{2}{3} \sqrt{2g} \times m(l - 0.1nH)H^{\frac{3}{2}} = 5.35m(l - 0.1nH)H^{\frac{3}{2}}, \quad (6)$$

or for approximate results,

$$Q = C(l - 0.1nH)H^{\frac{3}{2}} = 3.33(l - 0.1nH)H^{\frac{3}{2}}. \quad (7)$$

This last formula, suggested by Mr. Francis, assumes

* Lowell Hydraulic Experiments; Van Nostrand, New York, 1868.

that the discharge is from a reservoir infinitely large, so that the water approaching has received no initial velocity.

311. Increase of Volume due to Initial Velocity of Water.—When there is appreciable velocity of approach, let S be the section of stream in the channel of approach, and V the mean velocity of flow in the section S' , and h the height to which the velocity V is due, and Q' the volume enhanced by the initial velocity. Then

$$SV = Q', \text{ and } V = \frac{Q'}{S}, \text{ and } h = \frac{V^2}{2g}.$$

If the mean velocity, V , is to be determined from the surface motion of the water in the channel of approach, let V' be the surface motion; then, as will be shown in the consideration of flow of water in channels (§ 332), the mean velocity is, approximately, eight-tenths of the surface velocity, and $V = .8V'$, and $h = \frac{(.8V')^2}{2g}$.

Referring again to a parabolic segment of length equal to the unit of length of weir, Fig. 46, and let $H = ap$, and $h = sa$, and $\sqrt{2gH} = pp'$ and $\sqrt{2g(H+h)} = pt$.

The ordinate pp' of the segment app' is the projection of a parabolic segment whose volume equals the volume of flow when the depth upon the weir equals ap .

When the flow has no initial velocity the ordinate at $a = 0$, but when the flow has an initial velocity due to the height $sa = h$, the ordinate at a equals $\sqrt{2gh} = aa'$, and the ordinate at $p = \sqrt{2g(H+h)} = pt$, and any ordinate f , at a

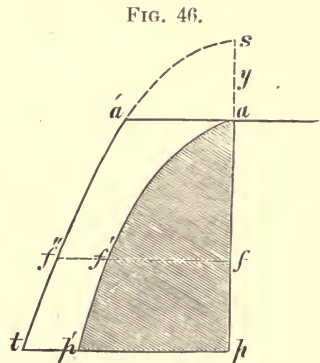

FIG. 46.

depth $h' = sf$, equals $\sqrt{2gh'} = ff''$, therefore the increase of volume of flow due to initial velocity is represented by the volume $aa'tpf'$, and the whole volume of flow by the volume $apta'$.

This last volume is the volume spt less the volume saa' , and equals, for unit of length,

$$\left\{ \frac{2}{3} (H + h) \sqrt{2g(H+h)} \right\} - \left\{ \frac{2}{3} h \sqrt{2gh} \right\} = \frac{2}{3} \sqrt{2g} \{ (H+h)^{\frac{3}{2}} - h^{\frac{3}{2}} \}. \quad (8)$$

Let Q' be the enhanced volume, and let H' be some depth, yp , upon the weir, that substituted for H in the ordinary formula for Q would give the value of Q' .

The formula then, if there are no end contractions, is

$$Q' = \frac{2}{3} ml \sqrt{2g} H'^{\frac{3}{2}}, \quad (9)$$

or, for approximate measures, including end contractions, if any,

$$Q = 3.33 (l - 0.1nH') H'^{\frac{3}{2}}. \quad (10)$$

To determine the value of H' from $(H + h)$, substitute the value of Q' in the equation (8) of volume for one unit of length, and we have

$$\frac{2}{3} \sqrt{2g} \{ (H + h)^{\frac{3}{2}} - h^{\frac{3}{2}} \} = \left\{ \frac{2}{3} \sqrt{2g} H'^{\frac{3}{2}} \right\},$$

and reducing, we have

$$H' = \{ (H + h)^{\frac{3}{2}} - h^{\frac{3}{2}} \}^{\frac{2}{3}}. \quad (11)$$

If the volume of flow ($Q = \frac{2}{3} ml \sqrt{2g} H'^{\frac{3}{2}}$) is known, and it is desired to find the depth H upon a weir of given length, then by transposition we have,

$$H = \left\{ \frac{Q}{\frac{2}{3} ml \sqrt{2g}} \right\}^{\frac{2}{3}}; \quad (12)$$

or, in case of initial velocity in the approaching water,

$$H = \left\{ \frac{Q}{\frac{2}{3}ml\sqrt{2g}} + h^{\frac{3}{2}} \right\}^{\frac{2}{3}} - h. \quad (13)$$

The first of these two values of H will give results sufficiently near for all ordinary practice, if the initial velocity does not exceed one-half foot per second.

In the above formulas of volume the symbols represent values as follows :

Q = volume due to natural flow, in cubic feet per second.

l = length of weir, in feet.

l' = effective length of weir, in feet.

m = coefficient of crest contraction, determined by experiment.

H = observed depth of water upon the weir, in feet.

S = section of channel leading to the weir, in square feet.

V = mean velocity of water approaching the weir, in feet per second.

h = head to which this velocity is due, in feet.

$2g$ = 64.3896, or 64.4 for ordinary calculations.

H' = head upon the weir, when corrected to include effect of initial velocity of approaching water.

Q' = volume of flow, including effect due to initial velocity of approaching water.

312. Coefficients for Weir Formulas.—The controlling influence of the contractions entitle them to a detailed study.

In Mr. Francis' formula for volume, quoted above, the end contraction is assumed to be a function of the depth, and the crest contraction to be compensated for by the coefficient C , of which m is the variable factor dependent upon the depth.

In the following table the quantities in columns *A*, *B*, *D*, *E*, *F* have been selected from Mr. Francis' table, the column *C* reduced from its corresponding column, and the column *G* computed. Each of the columns are means of a number of nearly parallel experiments, and they are here arranged according to depth upon the weir.

TABLE No. 68.
EXPERIMENTAL WEIR COEFFICIENTS.

A.	B.	C.	D.	E.	F.	G.
Length of weir = <i>l</i> , in feet.	Corrected depth upon weir = <i>H'</i> , in feet.	Quantity of water passing weir, in cu. ft. per sec. = <i>Q'</i> .	Quantity computed by $\frac{2}{3}m \sqrt{2g} (l - 0.1nH') H'^{\frac{3}{2}}$ in cu. ft. per sec.	Quantity computed by $3.33 (l - 0.1nH') H'^{\frac{3}{2}}$ in cu. ft. per sec.	Value of $C = \frac{2}{3}m \sqrt{2g}$.	Value of <i>m</i> .
9.997	.62	16.2148	16.0382	16.0502	3.3275	.622
9.997	.65	17.3401	17.1990	17.2187	3.3262	.622
9.995	.80	23.7905	23.8821	23.8156	3.3393	.624
9.997	.80	23.4304	23.4011	23.4391	3.3246	.621
9.997	.83	25.0410	24.8313	24.7548	3.3403	.624
9.995	.98	32.5630	32.3956	32.2899	3.3409	.624
9.995	1.00	33.4946	33.2534	33.2833	3.3270	.622
9.997	1.00	32.5754	32.5486	32.6240	3.3223	.621
9.997	1.06	36.0017	35.8026	35.5602	3.3527	.627
9.997	1.25	45.5654	45.4125	45.3608	3.3338	.623
9.997	1.56	62.6019	62.6147	62.8392	3.3181	.620
7.997	.68	14.5478	14.4581	14.4247	3.3368	.624
7.997	1.02	26.2756	26.2686	26.0333	3.3601	.628
					Mean,	.623

Mr. Francis points out the necessity of caution in applying the above formula for *Q'* beyond the limit covered by the experiments, but it occasionally becomes necessary to use some formula for depths both less and greater than is included in the above table.

After plotting with care the results obtained in various

experiments by different experimentalists, we suggest the following coefficients for the respective given depths, until a series of equal range shall be established by experiments with a standard weir gauge. At the same time, we advise that weirs be so proportioned that the depths upon them shall conform to the limits already covered by experiment, or at least between 4 and 24 inches depths, and with length equal to four times the depth.

TABLE No. 69.

COEFFICIENTS FOR GIVEN DEPTHS UPON WEIRS (in thin vertical plate).

Depths	1 in.	1½ in.	2 in.	3 in.	4 in.	6 in.	8 in.	10 in.
083 ft.	.124 ft.	.167 ft.	.25 ft.	.333 ft.	.500 ft.	.667 ft.	.833 ft.
Value of m6100	.6120	.6140	.6170	.6195	.6223	.6235	.6240
Value of C	3.263	3.274	3.285	3.301	3.314	3.329	3.336	3.338
<hr/>									
Depths	12 in.	14 in.	16 in.	18 in.	20 in.	24 in.	30 in.	40 in.	48 in.
	1 ft.	1.167 ft.	1.333 ft.	1.500 ft.	1.667 ft.	2.000 ft.	2.500 ft.	3.333 ft.	4.000 ft.
Value of m6241	.6242	.6243	.6242	.6241	.6240	.6232	.6226	.6200
Value of C	3.339	3.339	3.340	3.339	3.339	3.338	3.334	3.331	3.317

313. Discharges for Given Depths.—The following table of approximate flow over each foot in length of a sharp-crested rectangular weir has been prepared to aid in adjusting the proportions of weirs for given streams. End contractions are not here allowed for.* The coefficients C (in $CUH^{\frac{3}{2}}$) are taken from table above, and l equals unity.

The proportions of weir and its ratio to section of channel are here supposed to conform to the general suggestions given above.

* To compensate for a single end contraction, on a weir of any length, deduct one-tenth the volume due to one foot length of the same weir; for two contractions, two-tenths; and for n contractions, n -tenths of the volume for one foot length.

from the total length in feet a amount = to $\frac{1}{10}$ the head upon the weir in feet. Reduce the total length

TABLE No. 70.

DISCHARGES, FOR GIVEN DEPTHS OVER EACH LINEAL FOOT OF WEIR.

Head from still water in ft. = H .	$H^{3/2}$.	Cu. ft. per second for 1 ft. length = $C/H^{3/2}$.	Head.	$H^{3/2}$.	Cubic feet.	Head.	$H^{3/2}$.	Cubic feet.
.04	.0080	.0261	.46	.3120	1.0386	1.2	1.3145	4.3904
.05	.0112	.0365	.48	.3326	1.1072	1.3	1.4822	4.9506
.06	.0147	.0480	.50	.3536	1.1771	1.4	1.6565	5.5311
.07	.0185	.0604	.52	.3750	1.2483	1.5	1.8371	6.1341
.08	.0226	.0737	.54	.3968	1.3209	1.6	2.0239	6.7558
.09	.0270	.0881	.56	.4191	1.3951	1.7	2.2165	7.3987
.10	.0316	.1035	.58	.4417	1.4724	1.8	2.4150	8.0516
.11	.0365	.1195	.60	.4648	1.5506	1.9	2.6190	8.7317
.12	.0416	.1369	.62	.4882	1.6286	2.0	2.8284	9.4299
.13	.0469	.1536	.64	.5120	1.7080	2.1	3.0432	10.1460
.14	.0524	.1718	.66	.5362	1.7888	2.2	3.2631	10.8694
.15	.0581	.1906	.68	.5607	1.8705	2.3	3.4881	11.6189
.16	.0640	.2102	.70	.5875	1.9599	2.4	3.7181	12.3850
.17	.0701	.2303	.72	.6109	2.0380	2.5	3.9528	13.1668
.18	.0764	.2512	.74	.6366	2.1237	2.6	4.1924	13.9649
.19	.0828	.2726	.76	.6626	2.2118	2.7	4.4366	14.7783
.20	.0894	.2951	.78	.6889	2.2996	2.8	4.6853	15.6067
.22	.1032	.3407	.80	.7155	2.3883	2.9	4.9385	16.4501
.24	.1176	.3882	.82	.7426	2.4788	3.0	5.1962	17.3086
.26	.1326	.4377	.84	.7699	2.5699	3.1	5.4581	18.1809
.28	.1482	.4892	.86	.7975	2.6620	3.2	5.7243	19.0676
.30	.1643	.5445	.88	.8255	2.7557	3.3	5.9948	19.9687
.32	.1790	.5932	.90	.8538	2.8500	3.4	6.2693	20.7953
.34	.1983	.6572	.92	.8824	2.9463	3.5	6.5479	21.7194
.36	.2160	.7158	.94	.9114	3.0432	3.6	6.8305	22.6568
.38	.2342	.7761	.96	.9406	3.1407	3.7	7.1171	23.6074
.40	.2530	.8384	.98	.9702	3.2395	3.8	7.4076	24.5710
.42	.2722	.9020	1.00	1.0000	3.3390	3.9	7.7019	25.5472
.44	.2919	.9717	1.1	1.1537	3.8522	4.0	8.0000	26.5360

The *coefficients* derived from the experiments of Castel and D'Aubuisson, Du Buat, Poncelet and Lebros, Smeaton and Brindley, and Simpson and Blackwell, have been deduced by those eminent experimentalists to compensate for all contractions. In such cases, the ratio of length of weir to depth, especially where depth exceeds one-fourth the length, and the ratio of length to breadth of channel by which water approaches, exert controlling influences upon the coefficient.

The following table of coefficients, deduced by Castel, show the influence of depth and length.

In these experiments, Castel used for channel a wooden trough 2 feet 5½ inches wide, and the weir placed upon its discharging end was in each case of thin copper plate.

TABLE No. 71.
WEIR COEFFICIENTS, BY CASTEL.

Depth upon the crest.	CANAL, 2.427 feet wide. COEFFICIENTS, the lengths of the overfall being respectively											
	<i>Ft.</i> 2.42	<i>Ft.</i> 2.23	<i>Ft.</i> 1.96	<i>Ft.</i> 1.64	<i>Ft.</i> 1.31	<i>Ft.</i> 0.98	<i>Ft.</i> 0.65	<i>Ft.</i> 0.32	<i>Ft.</i> 0.16	<i>Ft.</i> 0.09	<i>Ft.</i> 0.06	<i>Ft.</i> 0.03
<i>Ft.</i>												
0.78	0.595	0.615	0.639
.72594	.614639
.65	0.596	.594	.614	0.629	.640	0.670
.50595	.613	.628	.641	.672
.52595	.613	.628	.642	.674
.45	0.603	.593	.592	.612	.628	.643	.675
.39	0.621	.604	.592	.591	.612	.628	.645	.678
.32	0.657	0.644	0.631	.621	.604	.593	.591	.612	.627	.648	.687
.26	0.662	.656	.644	.632	.620	.606	.595	.592	.612	.627	.652	.698
.19	.662	.656	.645	.632	.622	.610	.604	.595	.612	.628	.658	.713
.16	.662	.656	.644	.633	.626	.616	.611	.597	.613	.629	.663
.13	.662	.656	.645	.636	.632	.623	.619	.604	.614669
.09	.663	.660	.651	.642	.636	.631	.624	.618

If we plot certain series of experiments by Smeaton and Brindley, Poncelet and Lesbro, Du Buat, and Simpson and Blackwell, and take the corresponding series of coefficients from the resulting curves, we have the following results for the given depths and lengths.

TABLE No. 72.
SERIES OF WEIR COEFFICIENTS.

EXPERIMENTERS.	Lengths of weir, in feet.	DEPTHS UPON WEIR, IN FEET.											
		<i>Ft.</i> 0.075	<i>Ft.</i> 0.1	<i>Ft.</i> 0.15	<i>Ft.</i> 0.2	<i>Ft.</i> 0.25	<i>Ft.</i> 0.3	<i>Ft.</i> 0.4	<i>Ft.</i> 0.5	<i>Ft.</i> 0.6	<i>Ft.</i> 0.7	<i>Ft.</i> 0.8	<i>Ft.</i> 0.9
Smeaton and Brindley.....	0.5	.682	.667	.640	.623	.613	.605	.596	.593
Poncelet and Lesbros.....	.646	.625	.618	.608	.600	.597	.593	.590	.488	.485	.482	.480	.478
Du Buat.....	1.533	.673	.662	.645	.635	.629	.624	.622	.628	.635
Simpson and Blackwell....	3.0	.740	.725	.700	.678	.657	.638	.608	.592	.577	.560
" " " " ..	10.0	.615	.638	.673	.700	.718	.735	.754	.767	.780	.793

Within the limits of depths covered by the above experiments the coefficients all increase as the depths decrease, except in the last series belonging to the 10 foot weir. The curves in each instance begin to bend rapidly at depths of about three-tenths feet. In the two last series above, the convexities of the curves are opposed to each other, and the curves cross at a depth of .275 feet.

314. Vacuum under the Crest.—If the partitions *E* (Fig. 44) are prolonged below the weir so as to close the ends of the crest contraction, and the fall is slight to surface of tail water, the moving current will withdraw sufficient air from under the fall to produce a vacuum in the crest contraction, from which will result an increased flow over the weir. Such vacuum will take place if the surface of the tail water rises to the level of the crest when there is two and one-half or more inches depth flowing over the weir.

The tail water may rise near to the crest of the weir, if no vacuum is produced, without materially affecting the volume of flow.

315. Examples of Initial Velocity.—Mr. Francis found that with a half foot depth upon the weir, a half foot per second initial velocity of approach increased the discharge about one per cent., and with one foot upon the weir, one foot per second initial velocity increased the discharge about two per cent.

When initial velocity exists in the approaching water, and the flow is irregular, with eddies, results of submerged obstructions or irregular channel, the channel should be corrected, and, if necessary, a grating placed in the stream some distance above the weir, so that the water will approach with steady and even flow upon each side of the channel's axis, so that correct measurements may be taken of the height of the surface of the stream above the weir.

316. Wide-Crested Weirs.—If the crest of the weir is thickened, as in the case of an unchamfered plank, the jet tends to cross in contact with its full crest breadth, and the contraction is distorted. This is especially the case when the depth upon the weir is less than three inches.

If the edge receiving the current is not a perfect angle not greater than a right-angle, that is, if it is worn or rounded, the jet tends to follow the crest surface and distort the contraction.

In such cases the ordinary formula are not applicable, and the safest remedy is to correct the weir.

When the weir crest is about three feet wide, and level, with a rising incline to its receiving edge, as in Fig. 47, Mr. Francis suggests a formula for approximate measurements, when end contractions are suppressed, for depths between six and eighteen inches, as follows:

$$Q = 3.01208 l H^{1.53} \quad (12)$$

The coefficient m is here .563 approximately.

FIG. 47.

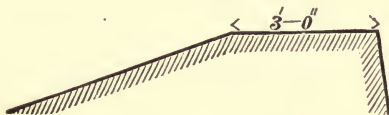

In Mr. Blackwell's experiments on weirs three feet wide, both level and inclined downward from the receiving edge to the discharge, coefficients m were obtained, as follows, applicable to the formula

$$Q = \frac{2}{3} m l \sqrt{2g} H^{\frac{3}{2}} \quad (13)$$

TABLE No. 73.

COEFFICIENTS FOR WEIR CRESTS THREE FEET WIDE.

Depths from still water upon the weir.	3 feet long, level.	3 feet long, inclined. 1 in 18.	3 feet long, inclined. 1 in 12.	6 feet long, level.	10 feet long, level.	10 feet long, inclined. 1 in 18.
<i>Feet.</i>	<i>m.</i>	<i>m.</i>	<i>m.</i>	<i>m.</i>	<i>m.</i>	<i>m.</i>
.083	.452	.545	.467381	.467
.167	.482	.546	.533479	.495
.250	.441	.537	.539	.492
.333	.419	.431	.455	.497515
.417	.479	.516518
.500	.501531	.507	.513	.543
.583	.488	.513	.527	.497
.667	.470	.491468	.507
.750	.476	.492	.498	.480	.486
.833465	.455
.917467
1.000

317. Triangular Notches.—Prof. James Thomson, of the University of Glasgow, proposed, in a paper read before the British Association at Leeds, in 1858, a *triangular* form of measuring weir. In his experiments with such weir, the depths of water varied from 2 to 4 inches, and the volumes from .033 to .6 cubic feet per second. From his experiments he derived the formula

$$Q = 0.317 H^{\frac{3}{2}}. \quad (14)$$

The flow for all depths would be through similar triangles, therefore an empirical formula applies with greater reliability to varying depths.

Prof. Thomson claimed that “in the proposed system the quantity flowing comes to be a function of only one variable—namely, the measured head of water—while in the rectangular notches it is a function of at least two variables, namely, the head of water, and the horizontal width

of the notch; and is commonly also a function of a third variable, namely, the depth from the crest of the notch down to the bottom of the channel of approach.”

When the stream is of such magnitude as to require a considerable number of triangular notches (say of 90° angles, or isosceles right-angled triangles) for a single gauge, the greatest nicety will be required to place the inverted *apices* all in the same exact level, so one measurement of depth only may suffice for all the notches.

The angles of the notches in each weir must conform exactly to the angles of the notch from which the empirical formula, or series of coefficients for given depths, was deduced.

For large volumes of water, the great length required for a sufficient number of notches, as well as depth required in each notch, are often obstacles not easily overcome, and the mechanical refinement necessary to ensure accuracy of measurement is often difficult of attainment.

318. Obstacles to Accurate Measures.—A correct measurement of the depth of water upon a weir is not so easily obtained as might be supposed by those unpractised in hydraulic experiments.

If the weir is truly level and the shoulders truly vertical, which are results only of good workmanship, and the length intended to be some given number of even feet, the chances are that only a skilled workman will have brought the length within one, two, or even three-thousandths of a foot of the desired length. Again, when the weir is truly adjusted and its length accurately ascertained, it is not easy to measure the depth upon the crest within one or two thousandths of a foot, without excellent mechanical devices for the purpose.

The errors due to agitation or ripple upon the water and

the capillary attraction of the measuring-rod have to be eliminated.

If the graduated measuring-rod is of clean wood, glass, steel, copper, or any metal for which water has an affinity, and its surface is moist, or is wetted by ripple, the water will, in consequence of capillarity, rise upon it above the true water level; or if, on the other hand, the rod is greasy, the water may, in consequence of molecular repulsion, not rise upon it to the true surface level.

These sources of error may not be of much consequence in gaugings of mountain streams, when the only object is to ascertain approximately the flow from a given watershed; but in measurements of power, and in tests of motors, turbines, and pumps, they are of consequence.

Upon a weir ten feet long, with one foot depth of water flowing over, an error of one-thousandth of a foot in measurement of depth will affect the computation of flow about two cubic feet per minute, and an error of one-thousandth of a foot (about $\frac{1}{8}$ of an inch) in length will affect the computation about two-tenths of a cubic foot per minute.

These amounts of water upon a twenty-five or thirty foot fall would have quite appreciable effects and value.

319. Hook Gauge.—A very ingenious and valuable instrument for accurately ascertaining the true level of the water surface, and depth upon a weir to still water, was invented by Uriah Boyden, C. E., of Boston, and used by him in hydraulic experiments as early as the year 1840.

This, shown in one of its forms, in Fig. 48, is commonly termed a *hook gauge*.

This gauge renders capillary attraction a useful aid to detect error, instead of being a troublesome source of error.

The instrument is firmly secured to solid substantial beams or a masonry abutment, so that it will be suspended

FIG. 48.

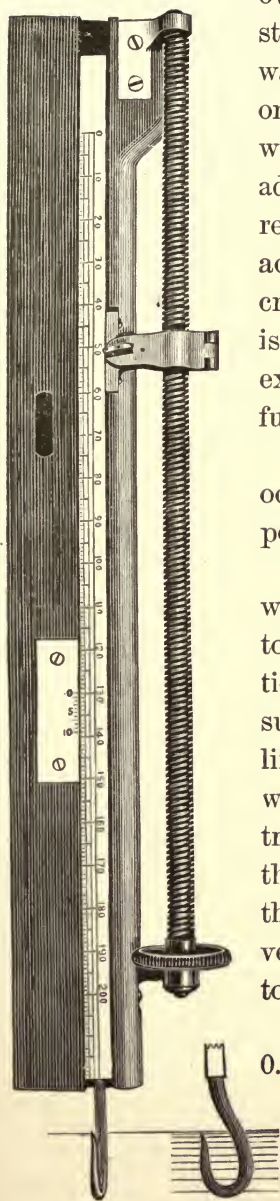

HOOK GAUGE.

over the water channel a few feet upstream from the weir, and where the water surface is protected, naturally or artificially, from the influence of wind and eddies. The gauge is here adjusted at such a height that when it reads zero the point of the hook shall accurately conform to the level of the crest of the weir; or the vernier reading is to be taken, with the hook at the exact weir level, for a correction of future readings.

This correction is to be verified as occasion requires between successive experiments.

When the full flow of water over the weir has become uniform, the hook is to be carefully raised by the screw motion, until the point just reaches the surface of the water. If the point is lifted at all above the water surface, the water is lifted with it by capillary attraction, and the reflection of light from the water surface is distorted and reveals the fact. The screw is then to be reversed and the point slightly lowered to the true surface.

In ordinary lights, differences of 0.001 of a foot in level of the water are easily detected by aid of the hook, and even 0.0001 of a foot by an experienced observer in a favorable light.

Such gauges are ordinarily gradu-

ated to hundredths of a foot and are provided with a vernier indicating thousandths of a foot, and fractions of this last measure may be estimated with reliability.

320. Rule Gauge.—For rougher and approximate measures a post is set at an accessible point on one side of the channel, above the weir, and its top cut off level at the exact level of the weir crest.

The depth of the water is measured by a rule placed vertically on the top of this post and observed with care.

321. Tube and Scale Gauge.—For summer measures, a pipe, say three-fourth inch lead, is passed from the dead water a little above the weir, through or around the weir, and connected to a vertical glass water tube set below the weir at a convenient point of observation. In such case a scale with fine graduations is fastened against the glass with its zero level with the weir. With such an arrangement quite accurate observations can be taken, as the water in a three-quarter inch tube will rise to the level of the water above the weir over the open mouth of the tube, due precautions being taken to keep sediment out of the tube.

CHAPTER XV.

FLOW OF WATER IN OPEN CHANNELS.

322. Gravity the Origin of Flow.—Gravity tends to cause motion in all bodies of water. Its effects upon the flow of water *under pressure* have been already discussed (Chap. XIII), as have also the effects of the reactions and cohesive attractions that retard its flow.

The same influences control the flow of water in open channels.

The fluid particles are attracted toward the earth's centre along that path where the least resistance is opposed.

An inclination of water surface of one-thousandth of a foot in one foot distance leaves many thousand molecules of water, but partially supported upon the lower side, and they fall freely in that direction, and by virtue of their weight press forward the advanced particles in lower planes.

FIG. 49.

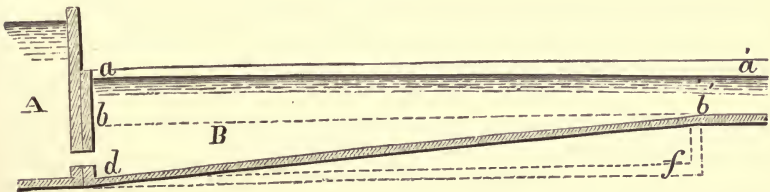

If water is admitted from the reservoir *A*, into the open canal *B* (Fig. 49), until it rises to the level *bb'*, it will there stand at rest, although the bottom of the channel is inclined, for its surface will be in a horizontal plane. The

resistances to motion upon opposite inclosing sides, and also upon opposite ends, balance each other. The algebraic sum of horizontal reactions from the vertical end bd , is exactly equal to the sum of the horizontal reactions from the inclined bottom db' , for the vertical projection, or trace of the inclined area, db' , exactly equals the vertical area bd .

The same equilibrium would have resulted if the bottom had been horizontal or inclined downward from d to f , and a vertical weir placed at $f'b'$, for the horizontal reaction from $f'b'$ would have been balanced by the sum of the horizontal reactions from bd and df .

A destruction of equilibrium permits gravity to generate motion.

If a constant volume of water is permitted to flow from the reservoir A into the channel B , the water surface will rise above the level bb' , when there will be less resistance at the end b' than at b , and the fluid particles, impelled by the force of gravity, will flow toward b' . When motion of the water is fully established, and the flow past b' has become uniform, there will result an inclination of the surface from a toward a' . This inclination, being a resultant of a constant force, gravity may be used as a measure of the portion of that force that is consumed in maintaining the velocity of flow.

323. Resistances to Flow.—Let the channel be extended from b' (Fig. 49) indefinitely, and with uniform inclination, as from a' to k (Fig. 50). Some resistance to flow will be presented by the roughness and attraction of the sides and bottom of the channel.

If the sides and bottom are of uniform quality, as respects smoothness or roughness, the amount of their *resistance* in each unit of length will be proportional to the sum of their areas, plus the water surface in contact with the

air reduced by an experimental fractional coefficient; and to the square of the velocity of flow past them; and inversely to the section of the stream flowing past them.

The exact resistance due to the air perimeter, has yet to be separated and classified by a series of careful experiments, but we may assume that the resistance of calm air for each unit of free surface will not exceed ten per cent. of that for like units of the bottom and sides of *smooth* channels, and will bear a less ratio for rough channels.

The air perimeter resistance will be increased by opposing and lessened by following winds.

Let R be the sum of resistances from the sides, bottom, and surface, in foot pounds per second; C , the contour, or wetted area of sides and bottom, and c , the width, or surface perimeter, in square feet; S , the sectional area of the stream, in square feet; and v , the mean velocity of flow of the stream, in feet per second; then we have for equation of resistance to flow, from sides, bottom, and surface, for one unit of length:

$$R = \frac{C + .1c}{S} \times (m) v^2, \quad (1)$$

and for any length, l , in lineal feet,

$$R = \frac{C + .1c}{S} \times l \times mv^2. \quad (2)$$

324. Equations of Resistance and Velocity.—

When the surface of the water is level the entire force of gravity acts through it as pressure, but when the surface is inclined, a portion of the pressure is converted into *motion*. Motion is measured by its *rate* or distance passed through in the given unit of time, and the rate is expressed by the term *velocity*.

In Fig. 50, let $a'k$ be the inclination of the water surface in a unit of length of the stream, then $a''k$ will be its vertical distance and $k'k$ its horizontal distance.

The effective action of gravity g to maintain motion, or velocity of the water, is dependent on this slope, and the slope is usually indicated by a ratio of the vertical distance to the horizontal distance.

FIG. 50.

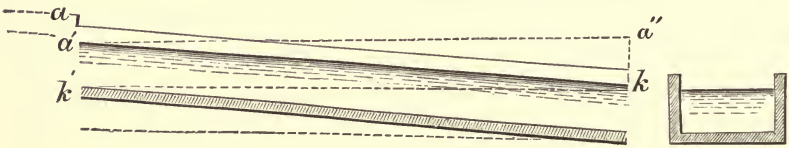

Let h'' be the vertical distance, $a''k$ and l be the horizontal distance $k'k$, and i the slope, or *sine* of the inclination, then the ratio of slope is $i = \frac{h''}{l}$.

If the sides and bottom of the channel opposed no resistance to flow, then the velocity v should be accelerated in the length $k'k$ an amount equal to the $\sqrt{2gh''}$, but the flow being uniform, the sum of the resistances in l just balance the accelerating force of gravity g , and the velocity v continues from a' to k at the same rate that had already been established when the stream reached a' , which was due to some height $aa' = h = \frac{v^2}{2g}$.

By transposition, we have $v = \sqrt{2gh}$.

If the sum of the resistances in the length $k'k$ balance the accelerating force due to the head $a''k = h''$, then we have

$$h'' = \frac{v^2}{2g} \times \frac{C + .1c_s}{S} \times lm. \quad (3)$$

$$v^2 = 2g \times \frac{S}{C + .1c_s} \times \frac{h''}{l} \times \frac{1}{m}. \quad (4)$$

The inverted fractional term $\frac{S}{C + .1c_s} = \frac{\text{Section}}{\text{Contour}^*}$ is termed in open channels the *hydraulic mean depth*, and the letter r is used to express it. Since i expresses the value of the *sine of the slope* $= \frac{h''}{l}$, we have

$$v = \left\{ \frac{2gr i}{m} \right\}^{\frac{1}{2}}. \quad (5)$$

$$h'' = \frac{lmv^2}{2gr}. \quad (6)$$

The total head H equals the heights $aa' + a''k = h + h''$, and

$$h + h'' = H = \frac{v^2}{2g} + \frac{lmv^2}{2gr} = \left\{ 1 + \frac{lm}{r} \right\} \times \frac{v^2}{2g}. \quad (7)$$

$$v = \left\{ \frac{2gH}{1 + m\frac{l}{r}} \right\}^{\frac{1}{2}}. \quad (8)$$

In *long* canals and rivers, with slopes not exceeding three feet per mile, the velocity head h is usually insignificant compared with the frictional head h'' , and may be neglected in the equation.

When the rate of flow is uniform, h is a constant quantity, independent of the length, and when the mean velocity is known may be taken, by inspection, from the table of "Heads (h) due to given Velocities," page 264.

The frictional head h'' increases with the length, hence the term l in the equation of h'' .

* In full pipes $\frac{S}{C}$ equals the sectional area divided by the full circumference, and is termed the *hydraulic mean radius* (§ 268), but in open channels the *contour* is the wetted perimeter; that is, the sum of the sides and bottom and air surface in contact with the water.

The mean velocity, which multiplied into the sectional area of the stream will give the volume of discharge, is a quantity often sought.

Neglecting the value of $h = \frac{v^2}{2g}$, which has given the stream its resultant motion, and taking the formula for h'' , the head balancing the resistance to flow,

$$h'' = \frac{lmv^2}{2gr},$$

and we have by transposition,

$$v = \left\{ \frac{2gr i}{m} \right\}^{\frac{1}{2}} = \left\{ \sqrt{\frac{2g}{m}} \times \sqrt{ri} \right\}, \quad (9)$$

in which v = mean velocity of all the films, in feet per sec.

r = hydraulic mean depth = $\frac{S}{C + 0.1c_s}$ in feet.

i = sine of inclination = $\frac{h}{l}$ in feet.

g = 32.2.

m = a comprehensive variable coefficient.

C = wetted earth perimeter.

c_s = surface (air) perimeter, taken at $0.1c_s$ for smooth channels, or $0.05c_s$ for rough channels.

l = length, referred to a horizontal plane.

h = vertical fall in the given length.

325. Equation of Inclination.—If the flow is to be at some predetermined rate, and it is desired to find the inclination, or slope to which the given velocity, for the given hydraulic mean radius, is due, then we have, by transposing again,

$$i = \frac{mv^2}{2gr}. \quad (10)$$

The member v , refers to the mean motion of all the fluid threads, or the rate which, multiplied into the section of the stream, gives the volume of flow.

326. Coefficients of Flow for Channels.—The value of the coefficient of flow m , is very variable under the influences of

- (a.) Velocity of flow, or inclination of water surface ;
- (b.) Hydraulic mean depth ;
- (c.) Mean depth ;
- (d.) Smoothness or roughness of the solid perimeter ;
- (e.) Direction and force of wind upon the water surface.

A complete theoretical formula for flow in a straight, smooth, symmetrical channel should have an independent coefficient for each of these influences, and other coefficients for influences of bends, convergence or divergence of banks, and eddy influences ; but such mathematical refinement belongs oftener to the recitation room than to expert field practice.

The comprehensive coefficient m , for open channels, which includes all these minor modifiers, is inconstant in a degree even greater than the coefficient m for full pipes, which we have already discussed (§ 270. Peculiarities of the Coefficient of Flow), to which the reader is here referred.

Experience teaches that m is *less* for large or deep, than for small or shallow streams ; for high velocities, than for low velocities ; and for smooth, than for rough channels.

Kutter adopted,* for open channels, the simple formula $v = c \sqrt{ri}$, and divided the values of c into twelve classes, to meet the varying conditions, from small to great velocities and sections of streams, and from smooth to rough sides

* *Vide* "Hydraulic Tables," trans. by L. D. A. Jackson. London, 1876.

and beds of channels. His c corresponds to $\sqrt{\frac{2g}{m}}$, as herein employed, and a portion of its values are :

$r.$	I.	II.	III.	IV.	V.	VI.	VII.	VIII.	IX.	X.	XI.	XII.
.5	85.5	82.5	77.9	72.4	66.9	61.1	55.8	49.5	43.2	36.7	29.7	22.5
.6	85.6	83.8	79.5	74.2	68.9	63.3	58.1	51.8	45.5	38.9	31.7	24.1
.7	87.5	84.8	80.7	75.6	70.5	65.1	59.9	53.8	47.4	40.7	33.4	25.5
.8	88.2	85.6	81.7	76.8	71.9	66.5	61.5	55.4	49.0	42.3	34.9	26.8
.9	88.8	86.4	82.6	77.9	73.0	67.8	62.9	56.9	50.5	43.8	36.2	28.0
1	89.3	87.0	83.3	78.7	74.0	69.0	64.1	58.2	51.8	45.0	37.5	29.1
2	60.3	53.7	45.9	36.7
3	65.0	58.7	50.9	41.5
4	68.3	62.1	54.5	45.0
5	70.6	64.8	57.3	47.8
6	72.5	66.8	59.5	50.1
7	74.0	68.5	61.3	52.0
8	75.2	69.9	62.9	53.7
9	76.3	71.1	64.2	55.1
∞	100	100	100	100	100	100	100	100	100	100	100	100

327. Observed Data of Flow in Channels.—Let us deduce the several values of m from various actual measurements of streams, and seek its curve of mean values, so that when it is a divisor of the simple fundamental equation $v = \sqrt{2gri}$, we shall have some degree of confidence in the use of this simple equation for channels and small streams. For this purpose we will select at random from data given by Messrs. Humphreys and Abbott, 1861; M.M. Darcy and Bazin, 1865; M. Heine Gerbenau, 1867; and sundry reports of U. S. Engineer Corps, and compute the experimental value of m for each case.*

It will be observed that the data cover ranges as follows : Of *sectional area*, from 9.5 to 15911 sq. feet; of *hydraulic mean depth*, from .96 to 15.9 feet; and of *velocity*, from .817 to 4.689 feet per second, or from three-quarters to about three and one-quarter miles per hour.

* The same, with additional data for large rivers, has been used by General H. L. Abbott, in a paper upon Gauging of Rivers, for the purpose of testing the new (Humphreys and Abbott) formula for flow of rivers, *vide* Jour. Franklin Institute, May, 1873.

TABLE NO. 74.

OBSERVED AND COMPUTED FLOWS IN CANALS AND RIVERS.

$$\left(v = \left\{ \frac{2grz}{m} \right\}^{\frac{1}{2}} \text{ AND } m = \left\{ \frac{2grz}{v^2} \right\} \right).$$

NAME OF STREAM.	A.	B.	C.	D.	E.	F.	G.
	Area = <i>S</i> .	Wetted Perimeter = <i>C</i> .	Hy. mean Depth = <i>r</i> .	Inclination = <i>i</i> .	Observed Velocity = <i>v</i> .	Value of Coefficient = <i>m</i> .	Computed Velocity = <i>v</i> .
	<i>Sq. ft.</i>	<i>Feet.</i>	<i>Feet.</i>	<i>Feet.</i>	<i>Feet.</i>		<i>Feet.</i>
Feeder Chazilly.....	9.5	9.9	0.96	0.000792	1.234	.03215	1.133
“ “.....	11.3	10.8	1.04	.000445	0.962	.03227	0.966
“ “.....	14.9	12.3	1.21	.000808	1.667	.02265	1.547
“ “.....	18.1	13.1	1.38	.000450	1.296	.02381	1.275
“ “.....	18.8	13.3	1.41	.000993	1.798	.02789	1.926
“ “.....	19.4	13.8	1.41	.000858	1.815	.02363	1.794
“ “.....	22.2	14.4	1.54	.000986	1.959	.02548	2.062
“ “.....	22.9	14.7	1.56	.000842	1.998	.02118	1.930
“ “.....	27.2	15.9	1.71	.000441	1.510	.02130	1.496
Feeder Grobois.....	10.1	10.2	0.98	.000555	0.984	.03617	1.063
“ “.....	11.8	11.3	1.05	.000310	0.817	.03155	0.852
“ “.....	17.2	12.5	1.38	.000450	1.326	.02274	1.278
“ “.....	23.0	14.1	1.63	.000479	1.434	.02445	1.502
“ “.....	25.9	14.1	1.71	.000515	1.746	.01860	1.617
“ “.....	26.8	15.7	1.71	.000493	1.683	.01917	1.585
“ “.....	30.8	17.3	1.78	.000275	1.467	.01465	1.231
“ “.....	32.0	17.3	1.85	.000330	1.411	.01974	1.381
Speyerbach.....	30.2	19.7	1.54	.000407	1.814	.01408	1.422
Canal.....	50.0	20.6	2.40	.000063	1.134	.00757	0.743
Lauter Canal.....	56.4	31.0	1.82	.000664	2.806	.01754	1.934
Saalach.....	86.9	61.2	1.38	.001036	2.155	.01982	1.934
“.....	96.7	71.8	1.34	.001136	1.970	.02585	1.980
“.....	119.0	32.5	3.70	.000698	2.723	.02243	3.523
C. and O. C. Feeder.....	121.0	32.7	3.70	.000699	3.032	.01811	3.527
River Haine.....	248.5	50.5	4.90	.000165	2.495	.00836	2.146
Isaa.....	300.1	161.6	1.85	.002500	3.997	.01864	3.812
“.....	306.4	53.4	5.70	.000155	2.558	.00869	2.328
Seine.....	1978	349	5.70	.000127	2.694	.01063	2.107
B. La Fourche.....	2868	230	15.7	.000044	2.789	.00572	3.110
“.....	3025	232	13.0	.000037	2.843	.00383	3.311
“.....	3738	238	15.7	.000045	3.076	.00481	3.145
Seine.....	4421	405	10.90	.000140	3.741	.00702	3.810
“.....	6372	439	14.50	.000140	4.232	.00730	5.062
“.....	8034	504	15.90	.000172	4.682	.00803	6.326
“.....	9522	518	18.40	.000103	4.689	.00268	5.991
Rhine.....	14150	1458	9.72	.000112	2.910	.00828	3.037
Upper Mississippi.....	15911	1612	9.87	.000074	2.941	.00544	2.554

328. Table of Coefficients for Channels. — From the experimental results we deduce the following values of *m* for the given hydraulic mean depths. Since *2g* is a constant, we have also the corresponding values $\sqrt{\frac{2g}{m}}$.

TABLE No. 75.

VALUES OF m FOR OPEN CHANNELS, AND VALUES OF $\sqrt{\frac{2g}{m}}$,
FOR GIVEN HYDRAULIC MEAN DEPTHS.

$r = \frac{S}{C}$.	m .	$\sqrt{\frac{2g}{m}}$.	$r = \frac{S}{C}$.	m .	$\sqrt{\frac{2g}{m}}$.
.25	.0500	35.89	7	.0096	81.90
.3	.0478	36.70	7.5	.0092	83.66
.4	.0440	38.25	8	.0088	85.54
.5	.0408	39.73	8.5	.0085	87.04
.6	.0378	41.27	9	.0081	89.16
.7	.0353	42.71	9.5	.0077	91.45
.8	.0332	44.04	10	.0074	93.28
.9	.0312	45.43	11	.0068	97.31
1.0	.0298	46.49	12	.0064	100.30
1.25	.0260	49.77	13	.0058	105.36
1.5	.0234	52.46	14	.0054	109.21
2	.0197	57.17	15	.0049	114.65
2.5	.0172	61.19	16	.0043	122.37
3	.0153	64.87	17	.0040	126.88
3.5	.0137	68.56	18	.0036	133.77
4	.0127	71.21	19	.0033	139.69
4.5	.0118	73.87	20	.0030	146.53
5	.0112	75.83	21	.0029	149.04
5.5	.0107	77.58	22	.0027	154.44
6	.0102	79.46	23	.0025	160.49
6.5	.0099	80.65	25	.0020	179.44

These values of m and of $\sqrt{\frac{2g}{m}}$ were inserted in the simple formula, $v = \left\{ \sqrt{\frac{2g}{m}} \cdot \sqrt{ri} \right\}$, and were used for a test to compute the velocities in the column G , of the above table of experimental data. The computed velocities may there be compared with the observed velocities. The results are satisfactory, if the exceeding difficulty of securing an accurate measurement of mean velocity of the stream and the probability of small errors are considered.

The *velocities* in the experimental table above, cover the range in ordinary practice, excepting the extremes of floods and droughts. The values of m are for the mean range of velocities there given. A considerable increase of velocity would reduce, or of roughness of channel would increase, the value of m for its given hydraulic mean depth. The influences of bends and eddies are to be eliminated from the formula, since the formula applies to a straight, smooth, symmetrical channel.

Jackson gives,* from Darcy, Bazin, Gauguillet, and Kutter, variable coefficients for the channel surfaces named, as follows. (These appear to be applicable to a constant value of v , equal to about 2.5.):

- .018, Well-planed plank.
- .020, Glazed pipes, or smooth cement lining.
- .022, Smooth cement and sand mortar lining.
- .024, Unplaned plank.
- .026, Brickwork and cut-stone lining.
- .034, Rubble masonry lining.
- .040, Canals, in very firm gravel.
- .050, Rivers in earth, free from stones and weeds.
- .070, “ with stones and weeds in great quantities.

329. Various Formulas of Flow Compared.—To compare this simple formula, having its variable m , with some of the more complex formulas, in the forms in which they are generally quoted in text-books and cyclopedias, four experiments are taken from the table, having their hydraulic mean depths and sectional areas of mean, minimum, and maximum values, and their velocities are computed by it. The velocities are then computed by well-known formulas upon the same data. The results are given in the following table:

* Hydraulic Manual. London, 1875.

TABLE No. 76.

FORMULAS FOR FLOW OF WATER IN CHANNELS, TO FIND THE VELOCITY.

Comparing results given by the several formulas.

AUTHORITY.	FORMULAS.	FEEDER CHAZILLY.*	LAUTER CANAL.†	SEINE.‡	B. LA FOURCHE.§
Eq. (9), § 324.	$v = \left\{ \frac{2g}{m} \cdot ri \right\}^{\frac{1}{2}}$	0.966	1.934	2.107	3.145
Du Buat	$v = \frac{88.51 (r^{\frac{1}{2}} - .03)}{\left(\frac{i}{z}\right)^{\frac{1}{2}} - \text{hyp. log.} \left(\frac{i}{z} + 1.6\right)^{\frac{1}{2}}} - .084(r^{\frac{1}{2}} - .03)$	1.929	3.627	2.411	2.143
Eytelwein ...	$v = (8975.43ri + .011589)^{\frac{1}{2}} - .1089$	1.932	3.184	2.442	2.382
Girard	$v = (10567.8ri + 2.67)^{\frac{1}{2}} - 1.64$	1.109	2.289	1.572	1.517
Prony.....	$v = (10607.02ri + .0556)^{\frac{1}{2}} - .236$	1.962	3.352	2.545	2.479
D'Aubuisson.	$v = (8976.5ri + .012)^{\frac{1}{2}} - .109$	1.932	3.184	2.435	2.418
Neville.....	$v = 140 (ri)^{\frac{1}{2}} - 11 (ri)^{\frac{1}{4}}$	2.161	3.695	2.778	2.706
Leslie.....	$v = \frac{100 \sqrt{r}}{\sqrt{\frac{i}{h}}}$	2.151	3.338	2.691	2.627
Pole.....	$v = \left\{ 10000 \frac{hS}{iC} \right\}^{\frac{1}{2}}$	2.151	3.438	2.691	2.627
Beardmore...	$v = 100 \sqrt{ri}$	2.151	3.438	2.691	2.627
Darcy and Bazin. }	$v = r \left\{ \frac{1000i}{.08534r + .35} \right\}^{\frac{1}{2}}$	1.047	2.086	2.166	2.582
M. Hagen....	$v = 4.39 \sqrt{r} (i)^{\frac{1}{2}}$	1.237	1.747	2.350	3.268
Humphreys and Abbott. }	$v = \left\{ \sqrt{.0081b + \left(\frac{225a \sqrt{i}}{\beta + W}\right)^2} - .09 \sqrt{b} \right\}^2 - \frac{2.4 \sqrt{b}}{1 + \beta}$	1.372	2.078	2.642	4.582

* FEEDER CHAZILLY. Area, 11.3 sq. ft. Hydraulic mean depth, 1.04 ft. Inclination, .000445. Observed velocity, 0.962 ft.

† LAUTER CANAL. Area, 564 sq. ft. Hydraulic mean depth, 1.82 ft. Inclination, .000664. Observed velocity, 2.106 ft.

‡ SEINE. Area, 1978 sq. ft. Hydraulic mean depth, 5.70 ft. Inclination, .000127. Observed velocity, 2.094 ft.

§ B. LA FOURCHE. Area, 3738 sq. ft. Hydraulic mean depth, 15.7 ft. Inclination, .000044. Observed velocity, 3.076 ft.

In the preceding table, the symbols in the formulas have values as follows :

r = hydraulic mean depth, in feet.

i = inclination of surface in straight channel, in feet.

l = length, in feet.

h = head, or fall in the given length, in feet.

S = sectional area of stream, in square feet.

C = wetted solid perimeter, in feet.

v = mean velocity of stream, in feet per second.

In the Humphreys and Abbotts' formula, the symbols have values as follows :

a = sectional area of stream, in square feet.

b = a function of depth = $\frac{1.69}{\sqrt{r + 1.5}}$.

p = wetted perimeter.

r = mean hydraulic depth.

i = inclination of surface of stream, corrected for bends.

W = width of stream.

v' = value of first term in the expression for v .

v = mean velocity of stream.

330. Velocities of Given Films.—Since the chief source of resistance to flow arises from the reactions at the perimeter of the stream, along the bottom and sides, A, B, B', A' , Fig. 51, and in a small degree along the surface A, A' , in contact with the air, it is evident that the points of minimum velocity will be along the solid perimeter, and the point of maximum velocity will be that least influenced by the resultant of all retarding influences. In a channel of symmetrical section, the point of maximum velocity should be, according to the above hypothesis, on a vertical line passing through the centre of the section and a little below the water surface, provided the surface was unin-

fluenced by wind. The velocity measurements of Darcy and Bazin* with an improved "Pitot" Tube, locate the thread of maximum velocity in a trapezoidal channel, at *a*, Fig. 51; a nearly concentric film of lesser velocity at *b*, and other films, decreasing regularly in velocity, at *c*, *d*, *e*, *f*, and *g*.

If the velocities, at the depths at which the given films cross a vertical centre line, are plotted as ordinates from a vertical line, as at *a*, *b*, *c*, etc., Fig. 52, their extremities will lie in a parabolic curve, and the degree of curvature will be less or greater as the velocity is less or greater, and as the bottom is smoother or rougher, for the given section. Velocity ordinates, plotted in the same manner for any horizontal section, as in the surface, or through *b*, *a*, *b*, *c*, etc., Fig. 51, will also have their extremities from shore

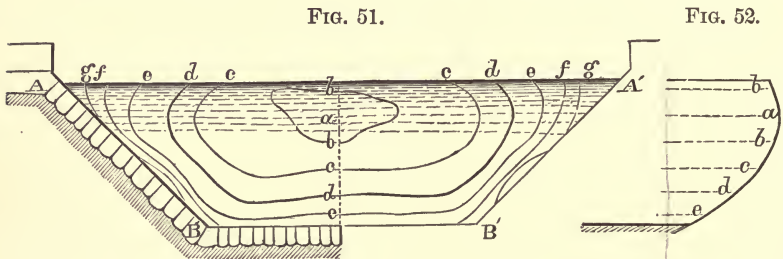

nearly to the centre in parabolic curves, the longest ordinate being near the centre of breadth of the canal, and the two side parabolas being connected by a curve more or less flat, according to breadth of canal. In Fig. 51, *d* indicates the film of mean velocity, and it cuts the central vertical line at nearly three-fourths the depth from the surface. In deep streams, or channels in earth, it is usually a little below the centre of depth.

* Tome XIX des Memoires presentes par divers Savants á l'Institut Imperial de France, Planche 4.

331. Surface Velocities.—The velocity of the centre of the surface, in symmetrical channels, or of the mid-channel in unsymmetrical sections, is that most readily obtainable by simple experiment.

For such velocity observations a given length, say one hundred feet of the smoothest and most symmetrical straight channel accessible is marked off by stations on both banks, and a wire stretched across at each end at right angles to the axis of the channel. Thin cylindrical floats are then put in the centre of the stream a short distance above the upper wire, by an assistant, and the time of their passing each wire accurately noted.

A transit instrument at each end station is requisite for very close observations. A small gong-bell, on a stand or post beside the transit, is to be struck by the observer the instant the centre of the float passes the cross-hair, or a signal is to be transmitted by an electric current, and the time, noted to the nearest quarter-second by a skillful assistant, is to be recorded.

The floats are sometimes of wax, weighted until its specific gravity is near unity; sometimes a short, thick vial, corked, and containing a few shot or pebbles; and sometimes a thin slice of wood cut from a turned cylinder, which for small channels may be two inches diameter. For large rivers, the float may be a short keg, with both heads in place, and weighted with gravel stones. The float is to be loaded so its top end will be just above the surface of the water. In broad streams, a small flag may be placed in the centre of the float.

If a number of floats are started simultaneously at known distances on each side of the axis of the channel, they should have each a special color-mark or conspicuous flag number, so that the time and distance from axis, at

each station, may be correctly noted for each individual float.

Du Buat made experiments with small rectangular and trapezoidal channels of plank, 141 feet long and about 18 inches wide, with depths from .17 to .895 feet, and velocities from .524 to 4.26 feet, to determine the ratio of the mean velocity v of the channel section to its central surface velocity, V . From the mean results he deduced the empirical formula,

$$v = (\sqrt{V} - .15)^2 + .02233. \quad (11)$$

This gives, when V is taken as unity,

$$v = .545 V.$$

Prony afterwards, reviewing the same experimental results, proposed the formula,

$$v = V \left(\frac{V + 7.782}{V + 10.345} \right) = .774 V. \quad (12)$$

Ximenes' experiments upon the River Arno, Raucort's upon the Neva, Funk's upon the Wesser, Defontaines and Brünning's upon the Rhine, on larger scales, gave mean velocities in a vertical line at the centre equal to .915 V , which being the maximum velocity in its horizontal plane, indicates, if the reduction of velocity toward the shore is considered, an approximate mean velocity,

$$v = .915 (.915 V) = .837 V. \quad (13)$$

Mr. Francis' experiments in a smooth, rectangular channel, with section about 10 feet broad and 8 feet deep, and velocity of 4 feet per second, indicates

$$v = .911 V. \quad (14)$$

In the Mississippi River, with depths exceeding one

hundred feet, Messrs. Humphreys and Abbott occasionally found v greater than V .

The Ganges Canal experiments at Roorkee, in 1875, by Capt. Cunningham, R. E., in a rectangular section 9 feet deep and 85 feet wide, gave the *mean surface* velocity equal to $.927 V$.

In any series of rectangular channels of like constant sectional areas or of like constant borders, it is seen, by simple mathematical demonstrations, that the *hydraulic mean depth* $= \frac{S}{C}$, is at its maximum when the breadth equals twice the depth.* Since the velocity of flow in a series of rectangular channels is nearly proportional to the square roots of their hydraulic mean depths, it follows that the proportions of such channels most favorable for high velocities is breadth equal twice depth.

These proportions of breadth to depth being adopted again for another series of rectangular channels of varying section, the velocities will again be sensibly proportional to the square roots of their hydraulic mean depths.

The ratio of v to V should be at its maximum when breadth equals twice the depth, and when the section is the maximum of the given series.

332. Ratios of Surface to Mean Velocities.—Let d = depth and b = breadth of rectangular channels, then letting depth be *unity* for a depth of 8 feet and approximately between 6 and 12 feet, and we shall have, according to the various recorded experiments, approximate values of the mean velocity v of flow in the channel, as compared with the central surface velocity V , as follows, for smooth channels:

* The influence of sectional profile upon flow is elaborately discussed by Downing, in *Elements of Practical Hydraulics*, p. 204, *et seq.* (London, 1875.)

When	$b = 2d$	then	$v = .920 V$	} (15)
“	$b = 3d$	“	$v = .910 V$	
“	$b = 4d$	“	$v = .896 V$	
“	$b = 5d$	“	$v = .882 V$	
“	$b = 6d$	“	$v = .864 V$	
“	$b = 7d$	“	$v = .847 V$	
“	$b = 8d$	“	$v = .826 V$	
“	$b = 9d$	“	$v = .804 V$	
“	$b = 10d$	“	$v = .780 V$	

The values of v should be slightly less for trapezoidal canals of equal sections, decreasing as the side slopes are flattened. The values of v will decrease also as the bottom and sides increase in roughness. The wind may enhance or retard the surface motion, and thus affect the mean velocity.

Since inclination of water surface, section of stream, hydraulic mean depth, and roughness of bottom and side, all affect the final result of flow, it is evident that experience and good judgment will aid materially in the selection of the proper ratio of v to V . A misapplication of formulæ that are valuable when judiciously used, may lead to gross errors; as, for instance, Prony's formula, deduced from experiments with Du Buat's small canal, gave result fifteen per cent. too small when tested by the flow in the Lowell flume, 10 feet wide and 8 feet deep, where the volume was proved by tube floats and weir measurements at the same time.

333. Hydrometer Gaugings.—When opportunity offers, the mean velocity for the whole depth should be measured, and thus some of the uncertainties accompanying surface measures be eliminated. Among the most reliable hydrometers that have been used for this purpose

in canals and the smaller rivers may be mentioned, *tin tubes* of length nearly equal to the depth of the stream; improved "*Pitot tubes*;" and "*Woltmann tachometers*."

334. Tube Gauge.—When the velocity measurements are to be taken with Francis' tubes or Krayenhoff poles, Fig. 53, a straight section of the stream is chosen, with smooth symmetrical channel, clear of weeds and obstructions. A length of one hundred or more feet, according to circumstances, is marked off by stations at each end on each bank, located so as to mark lines at right angles to the axis of the stream. A steel measuring chain, or wire with marks at equal intervals, is then to be stretched across at each end. The depths are then to be taken across the stream at each end, and at the centre if the banks are warped, at known intervals of a few feet, according to the formation of the banks and bottom of the stream, so that the sectional area of the stream shall be accurately known, and may be plotted. The soundings are all to refer to the same datum previously established, and referred to a permanent bench mark on the shore, which will greatly facilitate future observations or verifications at the same point.

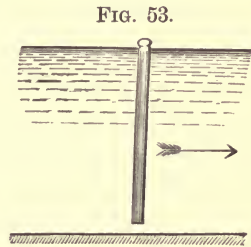

The requisite number of tight tin tubes, of say two inches diameter,* are then to be prepared, one for the axis of the stream, and others for short successive intervals on each side of the axis, all to be duly numbered for their respective positions. The length of each is to be such that it will float just clear of the bottom, and extend to a little above the water surface. The tube is to be loaded at one

* Tubes 40 feet long, 3 inches diameter, made up in sections, have been used by the United States Coast Survey Staff.

end with fine shot or sand, until it has the proper submergence in a vertical position.

The several tubes are to be started by signal, simultaneously if possible, from a short distance above the upper end station, so that they may cross the upper station as nearly as possible at the same instant. Their arrivals at the lower stations are to be carefully noted, and the time of transit of each recorded.

When the experiment has been several times repeated, the central and other tubes may be passed down singly, if the volume of the stream still remains constant, to verify the first observations. In the last observations, transits may conveniently be used to observe the passage by the stations, as suggested above for observing surface floats.

Suppose the stream to be divided transversely into seven sections, as in Fig. 54, then tubes 1, 2, 3, etc., may be started

FIG. 54.

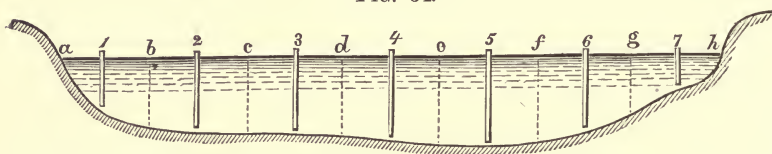

in the centres of their respective sections. The degree of accuracy with which they will move along their intended courses will depend upon the symmetrical regularity of flow, and very much upon the regularity of the side banks, and several trials may be necessary to get satisfactory side and even central measurements, since a slight obstruction, or a stray boulder upon the bottom, may distort the fluid threads in an unaccountable manner. The side floats have also a tendency away from shore.

The mean area of each of the sub-sections being known, and the mean velocity through each being ascertained,

their product gives the volume flowing through, and the sum of volumes of the sub-section gives the volume for the whole section.

When streams are in the least liable to fluctuations from the opening or closing of sluices above, or the opening or closing of turbine gates when the stream is used for hydraulic power, a hook-gauge (Fig. 48), should be placed over the axis of the stream where the usual vibration of surface is least, to watch for such fluctuations, since a variation in the mean level of the water surface one-hundredth of a foot will appreciably affect the velocity and volume of flow. If the tubes have much clearance they will not be influenced by the films of slowest velocity next the bottom. A clearance of six inches in a rectangular flume eight feet deep, may give an excess of three per cent. of velocity. The cross-section depths, in canals and shallow streams, may be taken with a graduated sounding-rod having a flat disk of three or four inches diameter at its foot, and in deep streams by a measuring-chain with a sufficient weight upon its foot to maintain it straight and vertical in the current. A good level instrument and level staff are requisite, however, for accurate work.

In broad streams the transverse stations may be located trigonometrically by two transits placed at the extremities of a carefully measured base line upon the shore.

335. Gauge Formulas.—The volume of flow through the mean transverse section (Fig. 54) is required.

Let s be the established *length*, or distance between the longitudinal end stations, and $t_1 t_2 t_3 \dots t_n$ the *times* occupied by the several tubes in passing along their respective courses between end stations; then the mean velocities in the respective sub-sections will be

$$\frac{s}{t_1} = v_1; \quad \frac{s}{t_2} = v_2; \quad \frac{s}{t_3} = v_3; \quad \dots \quad \frac{s}{t_n} = v_n.$$

Let the transverse breadths of the sub-sections be, $a_1 a_2 a_3 \dots a_n$.
 " " mean depths " " " " $d_1 d_2 d_3 \dots d_n$.
 " " mean velocities in " " " " $v_1 v_2 v_3 \dots v_n$.
 " " " volumes of flow in " " " " $q_1 q_2 q_3 \dots q_n$.

Then the whole sectional area in square feet, S , of the stream is,

$$S = a_1 \cdot d_1 + a_2 \cdot d_2 + a_3 \cdot d_3 + \dots + a_n \cdot d_n; \quad (16)$$

and the whole volume in cubic feet, Q , is

$$Q = (a_1 \cdot d_1) v_1 + (a_2 \cdot d_2) v_2 + (a_3 \cdot d_3) v_3 + \dots + (a_n \cdot d_n) v_n; \quad (17)$$

and the mean velocity in feet per second, v , of the whole section is,

$$v = \frac{Q}{S}. \quad (18)$$

The summary of field notes, beginning at a on the left shore, is:

	<i>Feet.</i>	<i>Feet.</i>	<i>Feet.</i>	<i>Feet.</i>	<i>Feet.</i>	<i>Feet.</i>	<i>Feet.</i>	
Breadths of sub-sections	a_1 16.45	a_2 20.00	a_3 24.85	a_4 32.00	a_5 29.50	a_6 26.80	a_7 18.24	} = S .
Mean depths of " "	d_1 4.85	d_2 9.74	d_3 12.37	d_4 15.68	d_5 12.52	d_6 9.71	d_7 4.79	
Mean velocities in the sub-sections... ..	v_1 2.25	v_2 3.80	v_3 4.62	v_4 5.00	v_5 4.65	v_6 3.75	v_7 2.00	
	<i>Cu. ft.</i>	<i>Cu. ft.</i>	<i>Cu. ft.</i>	<i>Cu. ft.</i>	<i>Cu. ft.</i>	<i>Cu. ft.</i>	<i>Cu. ft.</i>	
Volume in the sub-sections.....	q_1 179.5	q_2 740.2	q_3 1420.2	q_4 2508.8	q_5 1717.4	q_6 975.8	q_7 174.7	} = Q .

The sum of the several products of breadth into depth is $S = 1800.675$ square feet.

The sum of the several volumes is $Q = 7716.73$

The mean velocity for the whole section is $\frac{Q}{S} = \frac{7716.73}{1800.675} = v = 4.285$ feet per second.

If the tubes have several inches clearance at the bottom, a slight reduction, say two and a half per cent., from the computed velocity and volume are to be made, to compensate therefor.

336. Pitot Tube Gauge.—The Pitot tube has been used with a tolerable degree of success in many experiments upon a small scale. In its best simple form it has

been constructed of glass tubing swelled into a bulb near one end, and with tube of smaller diameter below the bulb bent at a right angle, and terminated with an expanded trumpet-mouth, as in Fig. 55.

For deep measures the mouth and bulb and a convenient part of the tube may be of copper, that part which is to project above the surface of the water being of glass, and the whole instrument may be attached to a vertical rod, which rests on the bottom, so as to be slid up and down on the rod to the heights of the several films whose velocities are required.

When in use, the bulb and tube are to be held vertically,

and the small trumpet-mouthed section exposed horizontally to the current so as to receive its maximum force into the mouth.

The object of the expanded bulb and contraction below the bulb is to reduce oscillation of the water within the tube to a minimum.

Theoretically the impulse of the current, acting as pressure on the water within the tube, should raise the surface of the water within, a height, $h = \frac{v^2}{2g}$, above the normal surface.

But owing to reactions from several parts of the tube, the entire force of the current does not act upon the column of water in the vertical section of the tube, hence the elevation of the water in the tube is $c_h h$ and

$$\frac{v^2}{2g} = c_h h \text{ and } v = \sqrt{2gc_h h}. \quad (19)$$

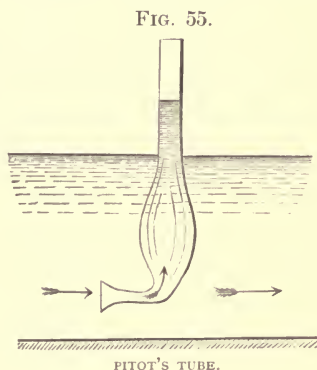

The coefficient c_v , for the given tube and the different velocities, must be determined by experiment before it can be used for practical measures.

The stream is cross-sectioned, as before described for the leading station when long tin tubes are used, and the mean velocity is ascertained from the mean velocity of the various superposed films taken in a vertical line at the centre of each sub-section.

The computations of volume are made in a manner similar to those when tubes are used.

Pitot introduced a plain tube bent at right angles as early as 1730, and by his measurements with it in the Seine and other streams, overthrew some of the hypotheses of the older hydraulicians.

It has since received a variety of forms and entered into a variety of combinations, among which may be mentioned the "Darcy-Pitot" tube, which, after an instantaneous closing of a stop-cock, can be lifted up for an observation, and the Darcy double tube, but there is still difficulty in reading by its graduations measures of small velocities, with sufficient accuracy, and the capillarity may be a source of error in unskillful hands.

The almost exclusive use of this instrument in improved forms by Darcy and Bazin in their valuable series of experimental observations, has given to it prominent rank among hydrometers.

337. Woltmann's Tachometer.—The most successful of all the simple mechanical hydrometers, not requiring the assistance of an electric battery, has been the revolving mill introduced by Woltmann in 1790, and known as "*Woltmann's Tachometer*," or *moulinet*. This current meter has from two to five blades, either flat or like marine propeller blades, set upon a horizontal shaft as shown in

Fig. 56, which represents the entire instrument* in its actual magnitude, for small canal and flume measures.

Upon the main axle, which carries the propeller, is a worm-screw, *G*. A series of toothed wheels and pinions, with pointers and dials similar to the registering apparatus

FIG. 56.

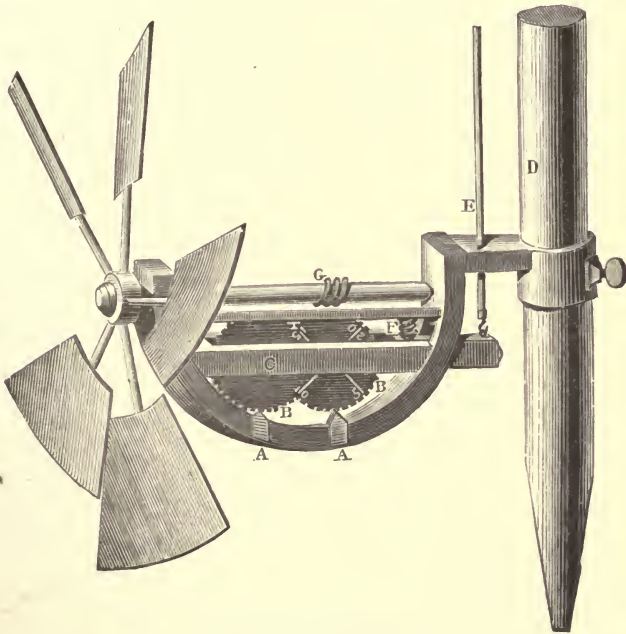

WOLTMANN'S TACHOMETER.

of a water or gas meter, are hung in a light frame, *C*, immediately beneath the main axle. One end of the frame is movable upward and downward, but when out of use is held down by a spring, *F*.

The whole instrument is secured by a set-screw upon an iron rod, *D*, on which it may be set at any desired height.

* Another form with two blades is illustrated in Stevenson's Canal and River Engineering. Edinburgh, 1872, p. 101.

When brought into practical use, the instrument is adjusted upon the rod,* so that when the staff rests upon the bottom, the main axle will be at the height of the film to be first measured. It is then placed in position with the propeller toward the approaching current and the main axle parallel with the direction of the current. The propeller will soon acquire its due velocity of revolution from the moving current, when the movable end of the frame carrying the recording train is lifted by the wire *E*, and the first toothed wheel brought into mesh with the worm-screw. If the train does not stand at zero, its reading is to be taken before the instrument is brought into position. The times when the train is brought into mesh with the worm-screw, and when disengaged, are both to be accurately noted and recorded.

Upon the slackening of the wire *E*, the spring *F*, instantly throws the train out of mesh, and it is held fast by the stud *A*, which engages between two teeth of the wheel. The instrument may then be raised and the revolutions in the observed time read off. In waters exceeding a few feet in depth there are usually pulsations of about one minute, more or less, intervals, and the instrument should be held in position until several of these have passed.

The velocities are thus measured at several heights on vertical centre lines in the several sub-sections, and the computations for mean velocity and volume completed as in the above described case when long tin tubes are used.

The blades of the propeller are usually set at an angle of about 70° , or with an equivalent pitch if warped as a propeller blade.

* Several moulinets upon the same staff, at known heights between bottom and surface, expedite the work and tend to greater accuracy.

338. Hydrometer Coefficients.—The number of revolutions of the main axle is nearly proportional to the velocity of the impinging current; but there is some frictional resistance offered by the mechanism, hence it is necessary that the coefficients for the given instrument and for given velocities be established by experiment, and tabled for convenient reference before it is put to practical use. These coefficients, which decrease in value as the velocity increases, may be ascertained, or verified, by placing the instrument submerged in currents of known velocity, or by causing it to move, submerged, through still water at known velocities.

An apparatus adapted to the last purpose is described by L' Abbe Bossut, and illustrated in Plates I and II, in "Experts * De Bossut."

If the instrument is to be tested in a reservoir of still water, by moving it with different known velocities through a given distance, let s be that distance, t the time consumed in passing the instrument from end to end stations, n the number of revolutions of the main axle in the given time t , c_o the coefficient of revolutions for the given velocity, and v the given velocity.

$$\text{Then } \frac{s}{t} = v; \text{ and } \frac{s}{n} = c_o; \text{ and } c_o n = s; \text{ and } \frac{c_o n}{t} = v.$$

Now if the instrument is placed in a current, and n is the observed number of revolutions in the given time, c_o may be taken from the table, or an approximate value of c_o assumed and nearer values determined by the formula

$$\frac{vt}{n} = c_o, \text{ when the velocity will be, } v = \frac{c_o n}{t}. \quad (20)$$

* Nouvelles Experiences sur la Resistance des Fluids; M. l'Abbe Bossut, Rapporteur. Paris.

Vide, also, Annales des Ponts et Chaussées, Nov. et Dec., 1847, and Journal of Franklin Institute, May, 1869, and Beaufoy's Hydraulic Experiments.

339. Henry's Telegraphic Moulinet.—An ingenious indicating current meter* has been invented by D. Farrand Henry, C. E., late assistant of the U. S. Lake Survey, and was tested by him with very satisfactory results in the surveys of the large streams joining and flowing from the great lakes of North America. The recording apparatus of this meter may be retained above the water surface in a position convenient for observation, while the revolving propeller is submerged at any desired depth. The two portions of the instrument are connected by flexible wires with an electric battery so that the circuit passes through the axle of the propeller. The electric circuit is closed for an instant during each revolution, when the lever of the register moves the first of the train of registering wheels forward one cog.

This meter gives promise of especial value for gaugings of deep waters and tidal estuaries.

340. Earlier Hydrometers.—Castelli's quadrant, or hydrometric pendulum, Boileau's horizontal gauge glass, Gauthey's and Brunning's pressure plates, Brewster's long screw-meter, and Lapointe's beveled gear-meter, have now all been superseded by the more perfect modern current meters.

341. Double Floats.—Various double-float combinations, having one float at the surface and a second near the bottom, connected with the first by a cord or fine wire rope, have been used both in Europe and America. The liability of erroneous deductions from the movements of such combinations has been ably discussed† by Prof. S. W. Robinson.

342. Mid-depth Floats.—The *mid-depth float* proves

* This meter is illustrated in the Jour. of the Franklin Inst., May, 1869, and Sept. 1871.

† Vide Van Nostrand's Eclectic Engineering Magazine, Aug., 1875.

most generally satisfactory of all float apparatus, excepting full-depth tubes, for gauging artificial channels and the smaller rivers.

This may consist of a hollow metal globe of say six inches diameter, with a cork-stopper or pet-cock at its lower vertical pole, which permits the partial filling of the globe with water until its specific gravity, submerged, is slightly in excess of unity. This globe is connected by a fine flexible wire with the smallest and lightest circular disk-float upon the surface that can retain the globe in its proper mid-depth position.

It is desirable that the float be controlled as fully as possible by the mid-depth velocity, where, in artificial channels and deep streams, the film of most constant velocity is found. The reactions and eddies that continually agitate all the particles that flow near the bottom and sides of the stream, and the wind pressure and motion along the surface, make the motions of all perimeter (so called) films very complex, and continually cause the parabolic velocity values in the central vertical plane to change between flatter and sharper curves, or to straighten out and double up, hinged, as it were, upon a mid-depth point; hence the bottom, side, and surface velocities are liable to great irregularities, and these irregularities are projected to some extent through the whole body of the water. These effects may be readily observed in a stream carrying fine quartz sand, upon a sunshiny day, if a position is taken so that the sunlight is reflected from the sand-grains to the eye. If in such case the eye and body is moved along with the current, the whole mass of water appears in violent agitation and the particles appear to move upward, downward, backward, forward, and across, with writhing motions, illustrating the method by which the water tosses up and bears

forward its load of sediment. In the midst of this agitation, the film having a velocity nearest to the mean resultant of onward progress is usually over the mid-channel of a straight course, and near to, or a little below, the centre of depth. The suspended float that takes this mean velocity is more certain to give a reliable velocity measure than that controlled by any other point of the stream section.

343. Maximum Velocity Floats.—If it is desired to place the submerged float in the film of maximum velocity in artificial channels, then this may be sought over the mid-channel, and between the surface and one-third the depth, according to the cross-section of the stream and velocity of flow. In a smooth rectangular section with depth equal to width, or with depth one-half width, it will probably be near one-third the depth, and higher as the depth of stream is proportionately less, until depth is only one-fourth breadth, when it will have quite, or nearly, reached the surface.

The film of maximum velocity may reach the surface in trapezoidal canals when depth of stream is only one-third mean breadth. It is at one-fourth depth in the trapezoidal channel, Fig. 51, in which bottom breadth equals twice depth.

In shallow streams, the maximum velocity is at or near the surface.

344. Relative Velocities and Volumes due to Different Depths.—When the mean velocity has been reliably determined in a channel, or small stream, at some given section, and for some particular depth, it is often desirable to construct a table of velocities and volumes of flow, for other depths in the same section, so that, if a reading of depth is taken at any time from a gauge established at that section, the velocity and volume due to the observed depth at that time may be read off from the table.

The inclination, or surface slope, $i = \frac{mv^2}{2gr}$, and the value of the coefficient of friction, $m = \frac{2gri}{v^2}$, may be observed within the ordinary extremes of depth at the time of the experimental measurement, if opportunity offers, or otherwise for the given experimental depth, and computed for the remaining depths.

Theory indicates that the variation of *velocity*, with varying depth, is nearly as the variation of the square root of the hydraulic mean radius, $= \sqrt{\frac{S}{C}}$, and the variation of *volume* of flow is nearly as the variation of the product of sectional area into the square root of hydraulic mean radius, $= S \sqrt{\frac{S}{C}}$.

These terms are readily obtained for the several depths, from measurement of the channel.

To compare new depths, velocities, and volumes, with the depth, velocity, and volume accurately measured by experiment, as *unity*,

let the experimental depth	be d , and the new depth	be d_1 ;
“ “ “ hy. mean rad.	“ r , “ “ “ hy. mean rad.	“ r_1 ,
“ “ “ slope	“ i , “ “ “ slope	“ i_1 ;
“ “ “ coef. of friction	“ m , “ “ “ coef. of friction	“ m_1 ;
“ “ “ sectional area	“ S , “ “ “ sectional area	“ S_1 ;
“ “ “ velocity	“ v , “ “ “ velocity	“ v_1 ;
“ “ “ volume	“ q , “ “ “ volume	“ q_1 .

The relative values of new depths, velocities, volumes, etc., will be

$$\frac{d_1}{d}; \quad \frac{v_1}{v}; \quad \frac{q_1}{q}, \quad \text{etc.,}$$

and $v : v_1 :: 1 : \frac{v_1}{v};$

$$q : q_1 :: 1 : \frac{q_1}{q}; \text{ etc.}$$

The ratio of v_1 to v is

$$\frac{v_1}{v} = \left\{ \frac{2gr_1i_1}{m_1} \right\}^{\frac{1}{2}} \div \left\{ \frac{2gr_i}{m} \right\}^{\frac{1}{2}} = \left\{ \frac{r_1i_1m}{rim_1} \right\}^{\frac{1}{2}},$$

$$\text{and} \quad v_1 = v \left\{ \frac{r_1i_1m}{rim_1} \right\}^{\frac{1}{2}} \quad (21)$$

$$q_1 = q \frac{S_1v_1}{Sv} = S_1v_1. \quad (22)$$

In long straight channels of uniform section, i_1 will be less than i for increased depths, and greater than i for reduced depths; but ordinarily (except with great velocities) their values will be so nearly equal to each other that they may be omitted from the equation without serious error, when the equation of velocity will become,

$$v_1 = v \left\{ \frac{r_1m}{rm_1} \right\}^{\frac{1}{2}}. \quad (23)$$

The variations in m cannot be neglected in relatively shallow channels.

For illustration of the equations, let Fig. 57 be a smooth

FIG. 57.

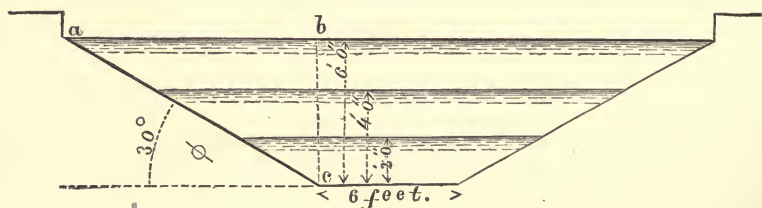

trapezoidal channel, 6 feet broad at the bottom, = e , and with side slopes inclined thirty degrees from the horizon, = ϕ .

During the experimental measurement, let the depth be 4 feet; the slope, one foot in one mile = $i = .000189$; the experimental velocity, 1.201 feet per second; and the experimental volume, 62.128 cubic feet per second.

The velocities and volumes are to be computed when the depths are 2 feet and 6 feet, respectively.

Let d be any given depth;

e " the bottom breadth, = 6 feet;

b " the mean breadth;

ϕ " the slope of the sides, = 30° ;

S " the sectional area;

C " the wetted earth perimeter.

Then we have for the given values of d :

ASSUMED VALUES OF d .	2 FEET.	4 FEET.	6 FEET.
$b = e + \frac{2d}{\tan \phi} \dots =$	12.93	19.86	26.79
$S = \frac{d^2}{\tan \phi} + de \dots =$	18.93	51.73	98.35
$C = e + \frac{2d \sec \phi}{\tan \phi} =$	14.00	22.00	30.00
$r = \frac{S}{C} \dots \dots \dots =$	1.35	2.30	3.28
$i \dots \dots \dots =$.0002	.000189	.000185
$m \dots \dots \dots =$.02396	.0187	.0146
$v_1 \dots \dots \dots =$.836	1.201	1.606
$q_1 \dots \dots \dots =$	15.825	62.128	157.95

With increase of depth, there is also increase of velocity; hence there are two factors to increase of volume.

Some practical considerations relating to *open canals* are given in Chap. XVII, following.

LIBRARY
UNIVERSITY OF
CALIFORNIA

FAIRMOUNT PUMPING MACHINERY, PHILADELPHIA.

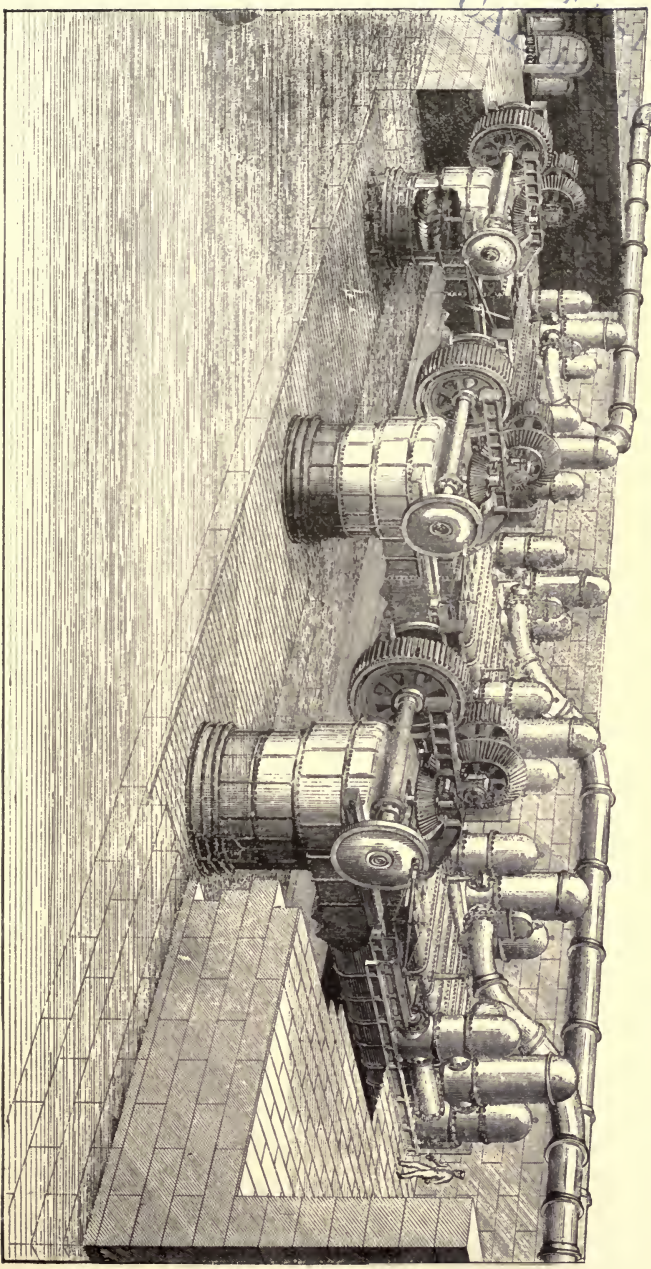
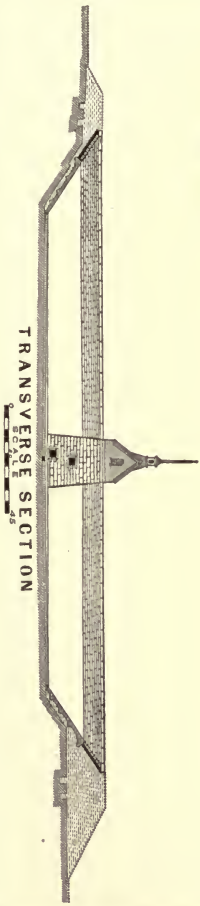
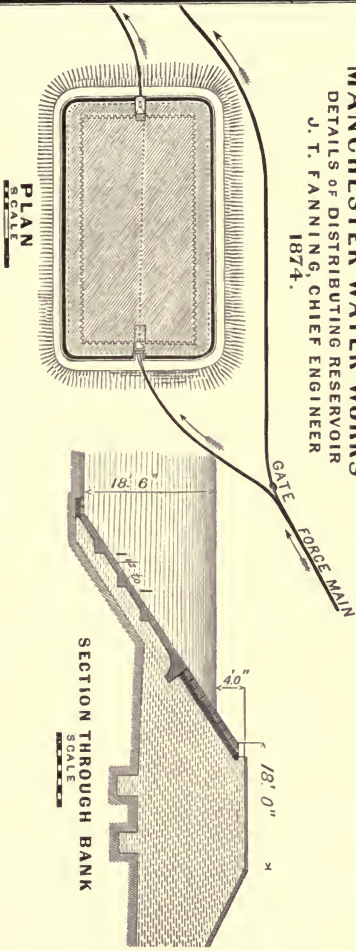

FIG. 58.

MANCHESTER WATER WORKS

DETAILS OF DISTRIBUTING RESERVOIR
J. T. FANNING, CHIEF ENGINEER
1874.



DISTRIBUTING RESERVOIR.

SECTION III.

PRACTICAL CONSTRUCTION OF WATER-WORKS.

CHAPTER XVI.

RESERVOIR EMBANKMENTS AND CHAMBERS.

345. Ultimate Economy of Skillful Construction.

—An earthwork embankment appears to the uninitiated the most simple of all engineering constructions, the one feature that demands least of educated judgment and experience. Possibly from such delusion has, in part, resulted the fact, which is patent and undeniable, that failures of reservoir embankments have exacted more terrible and appalling penalties of human sacrifice, and sacrifice of capital, than the weaknesses of all other hydraulic works together.

Each generation in succession has had its notable flood catastrophes, when its broken dams have poured deluges into the valleys, which have swept away houses and mills and bridges and crops, and too often twenty, fifty, or a hundred human beings at once.

Such devastations are scarcely paralleled by, though more easily averted by forethought, than those historical inundations when the sea has broken over the embanked shores of Holland and England, and when great rivers

have poured over their populous leveed plains, yet they seem to be quickly forgotten, except by the immediate sufferers who survived them.

The earliest authenticated historical records of the Eastern tropical nations describe existing storage reservoirs and embankments, and more than fifty thousand such reservoirs have been built in the Indian Madras Presidency Districts alone. Arthur Jacobs, B. A., says* of these Madras embankments, that they will average a half mile in length each, and the longest has a length of not less than thirty miles.

Two thousand years of practice seems to have developed but a slight advance of skill in the construction of earth-works, while their apparent simplicity seems to have distracted modern attention from their minute details, and to have led builders to the practice of false economy in some instances, and to the neglect of necessary precautions in others.

Among the recent disastrous failures may be mentioned the Bradfield or Dale Dyke embankment of the Sheffield, England, water-works, in 1864; the Danbury, Conn., water-works embankment, in 1866; the Hartford, Conn., water-works embankment, in 1867; the New Bedford, Mass., water-works embankment, in 1868; the Mill River, or Williamsburgh, Mass., embankment, in 1875; and Worcester, Mass., water-works embankment, in 1876. More than one hundred other breakages of dams are upon record for New England alone for the same short period.

The practical utility of streams is dependent largely upon the storage of their surplus waters in the seasons of their abundant flow, that they may be used when droughts would otherwise reduce their volume.

* *Vide* Paper read before the Society of Engineers, London.

Their waters are usually stored in elevated basins, whether stored for power, for domestic consumption, for compensation, or to regulate floods; and frequently single embankments toward the head-waters of streams suspends millions of tons of water above the villages and towns of the lower valleys. In other instances, embanked distributing reservoirs crown high summits in the midst of populous cities. These are good angels of health, comfort, and protection, when performing their appointed duties, but very demons of destruction when their waters break loose upon the hillsides.

Every consideration demands that a storage reservoir embankment shall be as durable as the hills upon which it rests. To this end, no water is to be permitted to percolate and gather in a rill beneath the embankment; its core must be so solid, heavy and impervious that no water shall push it aside, lift it up or flow through it, or follow along its discharge pipes or waste culvert; its core must be protected from abrasions and disintegrations; and its waste overfall must be ample in length and strength to pass the most extraordinary flood without the embankment being overtopped.

346. Embankment Foundations.—The foundation upon which the structure rests is the first vital point requiring attention, and may contain an element of weakness that shall ultimately lead to the destruction of the structure placed upon it.

The superposed drift strata beneath the surface layer of muck or vegetable soil may consist of various combinations of loam, gravel, sand, quicksand, clay, shale and demoralized rock, resting upon the solid impervious rock, or above an impervious stratum of sufficient thickness to resist the penetration of water under pressure. If the water is raised

fifty feet above the surface and there are thirty feet of pervious earth in the bed of the valley, then the pressure upon the bed stratum will be five thousand pounds, or two and one-half tons per square foot, which will tend to force the water toward an outlet in the valley below. That much of the natural earth is porous is well demonstrated by the freedom with which water enters on the plains and courses through the strata to the springs in the valleys, even without a head of water to force its entrance. Such porous strata must be cut off or sealed over, or the permanency and efficiency of the structure, however well executed above, cannot be assured.

If the valley across which the embankment is thrown is a valley of denudation, or if the embankment stretches across one or more ridges to cover several minor valleys with a broad lake, the waters in rising may cover the outcropping edges of coarse porous strata that shall lead the flowage by subterranean paths to distant springs where water had not flowed before. Hence the necessity of a thorough examination of the geological substructure of the valley, and of tests by trial shafts, supplemented by deep borings, of the site of the embankment and the hill-sides upon which it abuts. The test borings should cover some distance above and below the site of the embankment, lest a mere pocket filled with impervious soil be mistaken for a thick strata supposed to underlie the whole vicinity.

The trial shafts only, permit a proper examination of the covered rock, which may be so shattered, or fissured, as to be able to conduct away a considerable quantity of water, or to lead water from the adjoining hills to form springs under the foundations.

Several *deep* reservoirs constructed within a few years past have demanded excavations for cut-off walls, to a

depth of a hundred feet at certain points along their lines, but the porosity and the firmness of the strata in such cases are points demanding the exercise of the most mature judgment, that the work may be made sure, and at the same time labor be not wasted by unnecessarily deep cutting.

Thoroughness in the preliminary examination of the substrata of a proposed site may frequently result in the avoidance of a great deal of vexatious labor and enhanced cost that would otherwise follow from the location of an embankment over a treacherous sub-foundation.

347. Springs under Foundations.—If the excavation shall cut off or expose a spring that, when confined, will produce an hydrostatic pressure liable to endanger the outside slope of the embankment, it must be followed back by a drift or open cutting to a point from whence it may be safely led out in a small pipe below the site of the embankment.

348. Surface Soils.—Dependence cannot be placed upon the vegetable soil lying upon the site of an embankment to hold water under pressure, for it is always porous in a state of nature, as is also the subsoil to the depth penetrated by frost. The vegetable soil should be cleared from beneath the core of the embankment, and the subsoil rolled and compacted.

The vegetable soil will be valuable for covering the top and outside slope of the embankment.

If good hard-pan underlies the surface soil to a depth sufficient to make a strong foundation for the embankment, then its surface should be broken up to the depth it has been made porous by frost expansion, and the material rolled down anew in thin layers with a grooved roller of not less than two tons gross weight, or of one-half ton per lineal foot.

If next to the surface soil there is a layer of hard-pan within the basin to be flowed, and this hard-pan covers open and porous strata that extend below the dam, caution should be used in disturbing the hard-pan, lest the water be admitted freely to the porous strata, when it will escape, perhaps by long detour around the dam.

349. Concrete Cut-off Walls.—If the trench for the cut-off wall is deep and very irregular, it is well to level up in the cuts with a *water-proof* concrete well settled in place, and this may prove more economical than to cut the deep trench of sufficient width to receive a reliable puddle wall; also, the greater reliability of the concrete under great pressure should not be overlooked.

350. Treacherous Strata.—In one instance the writer had occasion to construct a low embankment, not exceeding twenty feet height at the centre, across an abraided cut through a plain. The embankment was to retain a storage of water for a city water supply, and the enclosed lake was to have an area of 200 acres.

The test pits and soundings developed the fact that the abraided valley and adjacent plains were underlaid with a stratum of fine sand twelve feet in thickness, which, when disturbed, became a quicksand, and if water was admitted to it, would flow almost as freely as water.

The sand lay in a compact mass, and would not pass water freely until disturbed. Above the sand was a layer of about three feet of fine hard-pan, and above this about three feet of good meadow soil had formed.

For this case the decision was, not to uncover the quicksand, but to seal it over in the vicinity of the embankment. The foundation of the embankment, and of the waste overfall which necessarily came in the centre of length of the embankment, was made of concrete of such thickness as to

properly distribute the weight of the earthwork and overfall masonry. Above the embankment, after a careful cleaning of the soil to the depth penetrated by the grass roots, the valley was covered with a layer of gravel and clay puddle for a distance of one hundred feet.

Beneath the toe of the inside slope, where the bottom puddle joined the concrete foundation, a trench was cut across the valley into the quicksand, as deep as could be excavated in sections, with the aid of the light pumping power on hand, and sheet piling placed therein and driven through the quicksand, and then the trench was filled around the piling with puddle, thus forming a puddle and plank curtain under the inside edge of the embankment.

Such expedients are never entirely free from risks, especially if a faithful and competent inspector is not retained constantly on the work to observe that orders are obeyed in the minutest detail.

In the case in question many thousands of dollars were saved, and the work has at present writing successfully stood the test of seven years use, during which time the most fearful flood storm recorded in the present century has swept over the section of Connecticut where the storage lake is situated.

351. Embankment Core Materials.—Rarely are good materials found ready mixed and close at hand for the construction of the core of the embankment. It is essential that this portion be so compounded as to be impervious.

If we fill a box of known cubical capacity, say one cubic yard, with shingle or screened coarse gravel, we shall then find that we can pour into the full box with the gravel a volume of water equal to twenty-eight or thirty per cent. of the capacity of the box, according to the volume of voids ;

or if we attempt to stop water with the same thickness (one yard) of gravel, we shall find that water will flow through it very freely. Then let the same gravel be dumped out upon a platform and twenty-eight per cent. nearly of fine gravel be mixed with it, so as to fill the voids equally, and the whole be put into the measuring-box. We now find that we can again pour in water equal to about thirty per cent. of the cubical measure of the fine gravel. Then let fine sand, equal to this last volume of water, be mixed with the coarse and fine gravel, and the whole returned to the measure. We now find that we can pour in water, though not so rapidly as before, equal to thirty-three per cent. approximately of the cubical measure of the sand, and we resort to fine clay equal to the last volume of the water to again fill the voids. The voids are now reduced to microscopic dimensions.

If we could in practice secure this strict theoretical proportion and thorough admixture of the material, we should introduce into one yard volume quantities as follows: Coarse gravel, 1 cubic yard; fine gravel, 0.28 cubic yard; sand, 0.08 cubic yard; and clay, 0.03 cubic yard, or a total of the separate materials of 1.39 cubic yards.

In practice, with a reasonable amount of labor applied to thoroughly mix the materials so as to fill the voids, we shall use, approximately, the following proportion of materials:

Coarse gravel.....	1.00	cubic yard.
Fine gravel.....	0.35	“ “
Sand.....	0.15	“ “
Clay.....	0.20	“ “
Total.....	1.70	“ “

which, when mixed loosely or spread in thin layers, will make about one and three-tenths yards bulk, and when

thoroughly compacted in the embankment, will make about one and one-quarter cubic yards bulk.

The voids now remaining in the mass may each be a thousand times broader than a molecule of water, yet they are sufficiently minute, so that molecular attraction exerts a strong force in each and resists flow of the molecules, even under considerable head pressure of water.

It will be interesting here to compare the weights of a solid block of granite with its disintegrated products of gravel and sand, taking for illustration a cubic foot volume.

TABLE No. 77.

WEIGHTS OF EMBANKMENT MATERIALS.

MATERIAL.	AV. WEIGHT. <i>cu. ft.</i>	SPECIFIC GRAVITY.	AV. VOIDS.
Granite.....	166 lbs.	2.662
Coarse Gravel.....	120 "	1.925	.28 per cent.
Gravel.....	116 "	1.861	.30 " "
Sharp Sand.....	110 "	1.765	.33 " "
Clay.....	125 "	1.440	.12 " "
Water.....	62.5 "	1.000

If the shingle is omitted and common gravel is the bulk to receive the finer materials, then the proportions in practice may be :

Common gravel.....	1.00 cubic yard.
Sand.....	0.86 " "
Clay.....	0.25 " "
	1.61

which, when loosely spread, will make about one and one-sixth yards bulk; and compacted, some less than one and one-tenth yards bulk.

Gravel is usually found with portions of sand, or sand and clay, already mixed with it, though rarely with a suf-

iciency of fine material to fill the voids. The lacking material should be supplied in its due proportion, whether it be fine gravel sand, fine sand, or clay. The voids must be filled, at all events, with some durable fine material, to ensure imperviousness.

It is sometimes found expedient to substitute for a portion of the fine sand or clay, portions of loam or selected soil from old ground, and on rare occasions peat, but neither peat nor loam should be introduced in bulk into the core of an embankment.

There is a general prejudice against the use of peat or surface soils in embankments, and the objections hold good when they are exposed to atmospheric influences. Mr. Wiggin remarks,* however, that a peat sea-bank which was opened after being built for seventeen years, exhibited the material as fibrous and undecayed as when first deposited.

Weight is a valuable property in embankment material, when placed upon a firm foundation, since, for a given bulk, the heavier material is able to resist the greater pressure.

Peat and loam are very deficient in the weight property, and therefore need the support of heavier materials. Clay is heavier than sand or fine gravel; shingle is heavier than clay; but the compound of shingle, gravel, sand, and clay, above described, is heavier than either alone, and weighs when compacted, for a given volume, nearly as much as solid granite.

Cohesiveness and *stability* are valuable properties in embankment materials, but sand and gravel lack permanent cohesiveness, and clay alone, though quite cohesive, is liable to slips and dangerous fissures, if unsupported; but a proper combination of gravel, sharp sand, and clay,

* *Embanking Lands from the Sea*, p. 20. London, 1852.

gives all the valuable properties of weight, cohesiveness, stability, and imperviousness.

352. Peculiar Pressures.—There are peculiar pressure influences in an earthwork structure that are not identical with the theoretical hydrostatic pressures upon a tight masonry, or fully impervious structure of the same form. The hydrostatic pressure upon an impervious face, whatever its inclination, might be resolved into its horizontal resultant (§ 171), and that resultant would be the theoretical force tending to push the structure down the valley, and would be equal to the pressure of the same depth of water acting upon a vertical face. The pressure would be, upon a vertical face, *per square foot*, at the given depths, as follows:

Depth, in feet.	5	10	15	20	25	30	35	40	45	50	60	70	80	90	100
Pressure, in lbs.....	312.1	624.3	936.4	1249	1561	1873	2185	2497	2809	3121	3746	4370	4994	5618	6243

The effective action of the theoretical horizontal resultant is neutralized somewhat upon an impervious slope by the weight of water upon the slope.

But all embankments are pervious to some extent. If with the assistance of the pressure, the water penetrates to the centre of the embankment, it presses there in all directions, upward, downward, forward and backward, and at a depth of fifty feet the pressure will be a ton and a half per square foot. Such pressure tends to lift the embankment, and to soften its substance, as well as to press it forward, and if in course of time the water penetrates past the centre it may reach a point where the weight or the imperviousness of the outside slope is not sufficient to resist the pressure, when the embankment will crack open and be speedily breached.

That portion of the embankment that is penetrated by

the water has its weight neutralized to the extent of the weight of the water, or at any depth, a total equal to the water pressure at that depth; thus, at fifty feet depth, that portion penetrated is reduced in its total weight a total of one and one-half tons per square foot.

Hence the value of imperviousness at the front as well as in the centre of the embankment, so that the maximum amount of its weight may be effective.

If water penetrates the subsoil beneath the embankment, as is frequently the case, it there exerts a lifting pressure according to its depth.

353. Earthwork Slopes.—If earth embankments of the forms usually given to them, and their subsoils also, were quite impervious, as a wall of good concrete would be, the embankments would have a large surplus of weight, and might be cut down vertically at the centre of their breadth, and either half would sustain the pressure and impact of waves with safety, but the vertical wall of earth would not stand against the erosive actions of the waves and storms. Surface slopes of earthwork are controlling elements in their design, and govern their transverse profiles.

Different earths have different degrees of permanent stability or of *friction* of their particles upon each other, that enable them to maintain their respective natural surface slopes, or *angles of repose*, against the effects of gravity, ordinary storms, and alternate freezings and thawings, until nature binds their surfaces together with the roots of weeds, grasses and shrubs. The coefficient of friction of earth equals the tangent of its angle of repose, or natural slope. The amount or value of the slope is usually described by stating the ratio of the horizontal base of the angle to its vertical height, which is the reciprocal of the tangent of the inclination.

The following data relating to these values are selected* in part from Rankine, and to them are added the angles at which certain earths sustain by friction other materials laid upon their inclined surfaces.

TABLE No. 78.

ANGLES OF REPOSE, AND FRICTION OF EMBANKMENT MATERIALS.

MATERIAL.	ANGLE OF REPOSE.	COEFFICIENT OF FRICTION.	RATIO OF SLOPE.	
			<i>Hori.</i>	<i>Vert.</i>
Dry sand, fine	28°	.532	1.88	to 1
“ “ coarse	30°	.577	1.73	“ 1
Damp clay	45°	1.000	1.00	“ 1
Wet clay	15°	.268	3.73	“ 1
Clayey gravel	45°	1.000	1.00	“ 1
Shingle	42°	.900	1.11	“ 1
Gravel	38°	.781	1.28	“ 1
Firm loam	36°	.727	1.38	“ 1
Vegetable soil	35°	.700	1.43	“ 1
Peat	20°	.364	2.75	“ 1
Masonry, on clayey gravel..	30°	.577	1.73	“ 1
“ “ dry clay	27°	.510	1.96	“ 1
“ “ moist clay. . .	18°	.325	3.08	“ 1
Earth on moist clay	45°	1.000	1.00	“ 1
“ “ wet clay	17°	.306	3.26	“ 1

Inclined earth surfaces are most frequently dressed to the slopes, having ratios of bases to verticals, respectively $1\frac{1}{2}$ to 1; 2 to 1; $2\frac{1}{2}$ to 1; and 3 to 1; corresponding respectively to the coefficients of friction 0.67, 0.50, 0.40, and 0.33, and to the angles of repose $33\frac{1}{2}^\circ$, $26\frac{1}{2}^\circ$, $21\frac{3}{4}^\circ$, and $18\frac{1}{4}^\circ$, nearly.

Gravel, and mixtures of clay and gravel, will stand ordinarily, and resist ordinary storms at an angle of $1\frac{1}{2}$ to 1, but the angle must be reduced if the slope is exposed to accumulations of storm waters or to wave actions, and upon

* Civil Engineering, p. 316. London, 1872.

broad lake shores the waves will reduce coarse gravel, if unprotected, to a slope of 5 to 1, and finer materials to lesser slopes. Complete saturation of clay, loam, and vegetable soil, destroys the considerable cohesion they have when merely moistened, and they become mud, and assume slopes nearly horizontal; hence the conditions to which the above table refers may be entirely destroyed and the angles be much flattened, unless the slopes are properly protected. On the other hand, the table does not refer to the temporary stability which some moist earths have in mass, for compact clay, gravel, and even coarse sand may, when their adhesion is at its maximum, or when their pores are partially and nearly filled with water, be trenched through, and the sides of the trench stand for a time, nearly vertical, at heights of from 6 to 15 feet. In such cases, loss or increase of moisture destroys the adhesion, and the sides of the trench soon begin to crumble or cave, unless supported.

354. Reconnoissance for Site.—Let us assume, for illustration, that a storage reservoir is to be formed in an elevated valley. The minimum allowable altitude being fixed upon, and designated by reference to a permanent bench mark in the outfall of the valley, the valley is then explored from the given altitude upward for the most favorable site for the storage basin, and for the site for an embankment, or dam, as the circumstances may require. We may expect to find a good site for the storage at some point where a broad meadow is flanked upon each side by abrupt slopes, and where those slopes draw near to each other at the outlet of the meadow, as is frequently the case. Having found a site that appears favorable, a preliminary reconnoissance with instruments is made to determine if the basin has the required amount of watershed and storage capacity, previously fixed upon (§ 59), and to determine

approximately the height the embankment or masonry dam must have. If the preliminary reconnoissance gives satisfactory results, then the site where the embankment can be built most economically and substantially is carefully sought, and test pits and borings put down at the point giving most promise upon the surface. It is important to know at the outset that the subsoil is firm enough to carry the weight of the embankment without yielding, and if there is an impervious substratum that will retain the ponded water under pressure. It is important also to know that suitable materials are obtainable in the immediate vicinity.

355. Detailed Surveys.—The preliminary surveys all giving satisfactory indications as respects extent of flowage, volume of storage, depth of water, inclination and material of shore slopes, soils of flowed basin, and the detailed surveys confirming the first indications, and also establishing that the drainage area and rainfall supplying the basin is of ample extent and quantity to supply the required amount of water (§ 24) of suitable quality (§ 100 *et seq.*); then let us suppose that the conditions governing the retaining embankment may best be met by a construction similar to that shown in Fig. 59, based upon actual practice.

356. Illustrative Case.—Here the water was raised fifty feet above the thread of the valley. The surface of the impervious clay stratum, containing a small portion of fine gravel, was at its lowest dip, thirty feet below the surface of the valley, and was overlaid at this point, in the following order of superposition, with stratas of sandy clay, coarse sand, quicksand, sandy marl, gravel and sand, gravelly loam, and vegetable surface soil, each of thickness as figured.

Gravel and sand and loam were obtainable readily in the immediate vicinity, but clay was not so readily procured, and must therefore needs be economized.

FIG. 59.

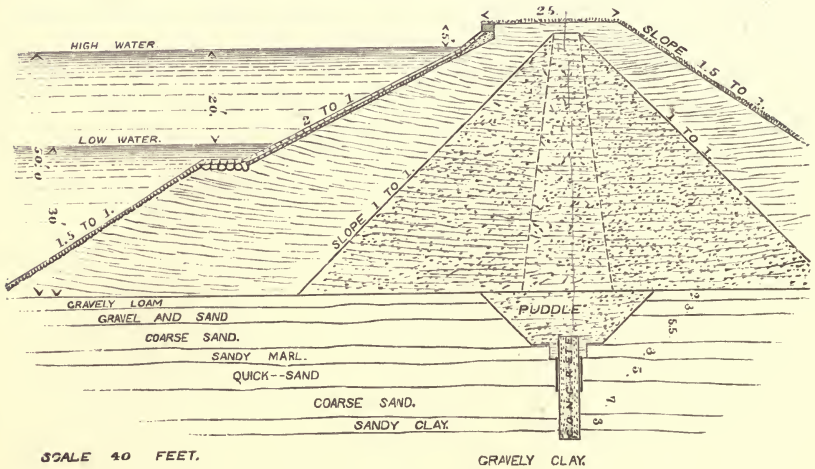

STORAGE RESERVOIR EMBANKMENT.

357. Cut-off Wall.—A broad trench was cut, after the clearing of the surface soil, down to the sandy marl, and then a narrow trench cut down to eighteen inches depth in the thick clay strata, finishing four feet wide at the bottom.

A wall of concrete, four feet thick, composed of machine-broken stone, four parts; coarse sand, one part; fine sand, one part; and good hydraulic cement, one part, was built up to eighteen inches above the top of the marl stratum.

The concrete was mixed with great care, and the materials rammed into the interstices of the bank, to insure imperviousness in the wall, and to prevent water being forced down its side and under its bottom. Puddle, of one part mixed coarse and fine sharp gravel, one part fine sand, and one part good clay then filled the broad trench up to the surface of the embankment foundation.

358. Embankment Core.—The core of the embankment was composed of carefully mixed coarse and fine gravel, sand, and clay, in the proportions given above

(p. 340), requiring for one cubic yard of core in place, approximately :

Coarse gravel.....	.74	cubic yard.
Fine "26	" "
Sand.....	.11	" "
Clay.....	.15	" "
	1.26	" "

When measured by cart-loads, these quantities became eight loads* of mixed gravels, one load of sand, and two loads of clay, the cubic measure of each load of clay being slightly less than that of the dry materials. The gravel was spread in layers of two inches thickness, loose, the clay evenly spread upon the gravel and lumps broken, and the sand spread upon the clay. When the triple layer was spread, a harrow was passed over it until it was thoroughly mixed, and then it was thoroughly rolled with a two-ton grooved roller, made up in sections, the layer having been first moistened to just that consistency that would cause it to knead like dough under the roller, and become a compact solid mass.

Such a core packs down as solid, resists the penetration or abrasion of water, nearly as well, and is nearly as difficult to cut through as ordinary concrete, while rats and eels are unable to enter and tunnel it.

The proportions adopted for the core was—a thickness of five feet at the top at a level three feet above high-water mark, and approximate slopes of 1 to 1 on each side.

For the maximum height of fifty-four feet this gave a breadth of 113 feet base.

This core was abundantly able to resist the percolation of the water through itself, and to resist the greatest pres-

* Seven loads of coarse and three loads of fine gravel make, when mixed, about eight loads bulk.

sure of the water, and had these been the only matters to provide for, the embankment core would have been the complete embankment.

359. Frost Covering.—Frost would gradually penetrate deeper and deeper into that part of the work above water and into the outside slope, and by expansions make it porous and loose to a depth, at its given latitude, of from four to five feet. A frost covering was therefore placed upon it, and carried to a height on the inside of five feet above high-water line, and of just sufficient thickness at high-water line to protect it from frost.

The frost-covering was composed of such materials as could be readily obtained in the vicinity of the embankment. It was built up at the same time, in thin layers, with the core, and the whole was moistened and rolled alike, making the whole so compact as to allow no apparent “*after settlement.*” The *wave slope* was built eighteen inches full, and then dressed back to insure solidity beneath the pavement.

The core of an embankment should be built up at least to the highest flood level, which is dependent upon length of overfall as well as height of its crest, and the frost-covering should be built of good materials to at least three feet above maximum flood level.

360. Slope Paving.—The exterior slope, when soiled, was dressed to an inclination of $1\frac{1}{2}$ to 1; the interior slope was made 2 to 1 from one foot above high water down to a level, three feet below proposed minimum low water, where there was a berm five feet wide, and the remainder of the slope to the bottom was made $1\frac{1}{2}$ to 1. The lower interior slope was paved with large cobbles driven tightly, the berm with a double layer of flat quarried stone, and the upper slope, which was to be exposed to wave action, was covered

with one foot thickness of machine-broken stone, like "*road metal*," and then paved with split granite paving-blocks of dimensions as follows: Thickness, 10 to 14 inches; widths, 12, 14, or 16 inches; and lengths, 24 to 48 inches.

A granite ledge, in sheets favorable for the splitting of the above blocks, was near at hand, and supplied the most economical slope paving, when labor of placing and future maintenance was considered. From one foot above high water to the underside of the coping, the paving had a slope of 1 to 1, and the face of the coping was vertical.

361. Puddle Wall.—The policy might be considered questionable of using clay in so large a section of the embankment, when the haulage of the clay was greater than of any of the other materials, and when the clay might be confined to the lesser section of the usual form of *puddle wall*. These methods of disposing the clay were compared in a preliminary calculation, both upon the given basis, and that of a puddle wall of minimum allowable dimensions, viz., five feet thick at the top and increasing in thickness on each side one foot in eight of height, which gave a maximum thickness of 18.6 feet at base with 54 feet height. (See dotted lines in Fig. 59.)

The estimate of loose materials for each cubic yard of complete core was—coarse gravel, .74 cu. yard; fine gravel, .26 cu. yd.; sand, .07 cu. yd.; and clay, .15 cu. yd.; and for puddle wall of equal parts of gravel and clay—gravel .59 cu. yd., and clay .59 cu. yd.

This calculation gave the excess of clay in the maximum depth of embankment, less than 4 cubic yards per lineal foot of embankment, and the excess at the mean depth of thirty feet, about three-fourths yard per lineal foot of embankment.

The difference in estimated first cost was slightly against

the mixed core, but in that particular case this was considered to be decidedly overbalanced by more certainly insured stability, more probable freedom from slips and cracks in a vital part of the work, and by the additional safety with which the waste and draught pipes could be passed through the core.

The value of puddle in competent hands has, however, been demonstrated in many noble embankments. It is usually placed in the centre of the embankment, as in Fig. 61, and occasionally near the slope paving, as in Fig. 62, from a design by Moses Lane, C. E.

362. Rubble Priming Wall. — The drift formation presents a great variety of materials; but not always such as are desired for a storage embankment, in the immediate vicinity of its site. The selection of proper materials often demands the best judgment and continued attention of the engineer. Clay, which is often considered indispensable in an embankment, may not be found within many miles.

Fig. 60 (p. 84) gives a section of an embankment constructed where the best materials were a sandy gravel and a moderate amount of loam, but abundance of gneiss rock and boulders were obtainable close at hand.

Here a *priming wall* of thin split stone was carried up in the heart of the embankment from the bed-rock, which was reached by trenching. Each stone was first dashed clean with water, and then carefully floated to place in good cement mortar, and pains taken to fill the end and side joints, and exceeding care was taken not to move or in any way disturb a stone about which the mortar had begun to set. No stones were allowed to be broken, spalted, or hammered upon the wall, neither were swing chains drawn out through the bed mortar. The construction of a watertight wall of rubble-stone is a work of skill that can be

performed, but the ordinary layer of foundation masonry in cement mortar seems no more to comprehend it than would a fiddler at a country dance the enchanting strains of a Vieuxtemps or Paganini.

Grouting such rubble-stone walls, according to the usual method, will not accomplish the desired result, and is destructive of the most valuable properties of the cement.

363. A Light Embankment.—In this embankment (Fig. 60), selected loam and gravel were mixed in due proportions on the upper side of the priming wall, so as to insure, as nearly as possible, imperviousness in the earth-work. The entire embankment was built up in layers, spread to not exceeding four or five inches thickness, and moistened and rolled with a heavy grooved roller.

The cross-section of this work is much lighter than that advised by several standard authorities, both slopes being $1\frac{1}{2}$ to 1, but great bulk was modified by the application of excellent and faithful workmanship. This embankment retains a storage lake of sixty-six acres and thirty feet maximum depth. It was completed in 1868, and has proved a perfect success in all respects. This work fills the offices of both an impounding and distributing reservoir, in a gravitation water supply to a New England city.

364. Distribution Reservoirs.—Distributing reservoirs are frequently located over porous sub-soils and require puddling over their entire bottoms and beneath considerable portions of their embankments, and puddle walls are usually carried up in the centres of their embankments or near their inner slopes.

The same general principles are applicable to distributing as to storage reservoir embankments.

365. Application of Fine Sand.—Fig. 58 (p. 333) illustrates a case where the bottom was puddled with clay, but a

sufficiency of clay to puddle the embankments was not obtainable. The embankment is here constructed of gravel, coarse sand, very fine sand, and a moderate amount of loam. The materials were selected and mixed so as to secure imperviousness to the greatest possible extent, and were put together in the most compact manner possible, and have proved successful. This has demonstrated to the satisfaction of the writer that very fine sand may replace to a considerable extent the clay that is usually demanded, and his experience includes several examples, among which, on a single work, is more than three-fourths of a mile of successful embankment entirely destitute of clay, but sand was used with the gravel, of all grades, from microscopic grains to coarse mortar sand, and a sufficiency of loam was used to give the required adhesion. The outside slopes were heavily soiled and grassed as soon as possible.

FIG. 61.

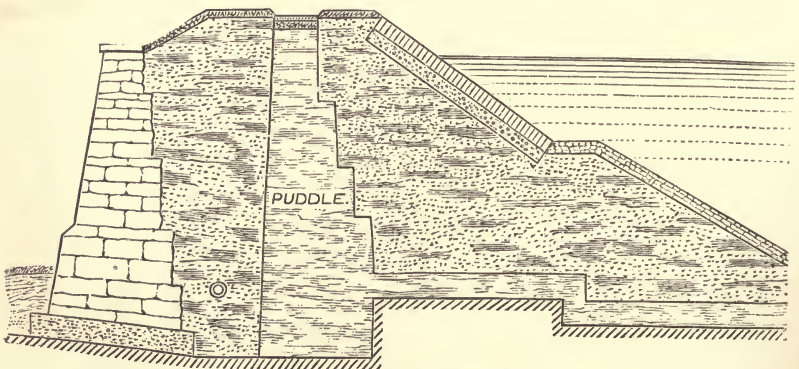

REVETTED RESERVOIR EMBANKMENT.

366. Masonry-faced Embankment.—When there is a necessity for economizing space, one or both sides of an embankment may be faced with masonry.

An example of such construction is selected from the practice of a successful engineer in one of the Atlantic

States, and is shown in Fig. 61. A method of introducing clay puddle into a central wall in the embankment, beneath the embankment, and on the reservoir bottom, is also here shown. The puddle of the reservoir bottom is usually covered with a layer of sand.

367. Concrete Paving.—The lower section of the slope paving of the distributing reservoir, Fig. 58, was built up of concrete, composed of broken stone 4 parts; coarse sand 1 part; fine sand 1 part; and hydraulic cement 1 part. The cement and sand were measured and mixed dry, then moistened, and then the stone added and the whole thoroughly worked together. The concrete was then deposited and rammed in place, building up from the base to the top, in sections of about forty feet length. A very small quantity of water sufficed to give the concrete the proper consistency, and if more was added the concrete inclined to quake under the rammer, which was an indication of too much water.

The general thickness of the concrete sheet is ten inches, and there is in addition four ribs upon the back side to give it bond with the embankment, and to give it stiffness, and also to check the liability of the sheet being lifted or cracked by back pressure from water in the embankment, when the water in the reservoir may be suddenly drawn down.

The upper part of the slope that is exposed to frost is of granite blocks laid upon broken stone. The layer of broken stone at the wave line is fifteen inches thick, which is none too great a thickness to prevent the waves from sucking out earth and allowing the paving to settle.

368. Embankment Sluices and Pipes.—Arched *sluices* have been in many cases built through the foundation of the embankment and the discharge pipes laid therein, and then a masonry *stop-wall* built around the pipes near

the upper end of the sluice. By this plan the pipes are open for inspection from the outside of the embankment up to the stop wall. If the sluice is not circular or elliptical, its floor should be counter-arched, and its sides made strong, to resist the great pressure of the water that may saturate the earth foundation.

FIG. 62.

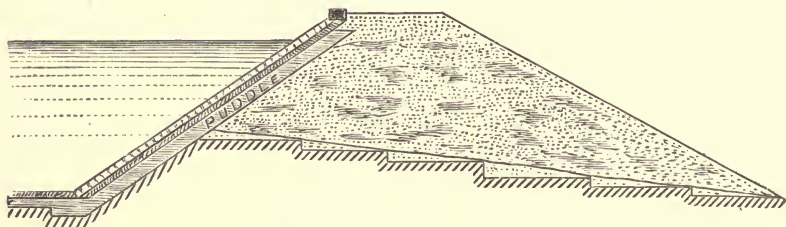

SLOPE PUDDLED RESERVOIR EMBANKMENT.

Such a sluice is sometimes built in a tunnel through the hillside at one end of the embankment. The latter plan, when the upper end of the tunnel is through rock, is the safer of the two, otherwise there is no place where it can be more safely founded, constructed, and puddled around, than when it is built upon the uncovered foundation of the embankment, either at the lowest point in, or upon, one side of the valley, since every facility is then offered for thorough work, which cannot so easily be attained in an earth tunnel obstructed by timber supports.

A circular or rectangular well rising above the water surface, is usually built over the upper end of the sluice, and contains the valves of the discharge pipes, and inlet sluices at different heights, admitting water to the pipes from different points below the surface of the reservoir.

When the sluice is used for a waste-sluice, also, the stop-wall is omitted, and the sluice well rises only to the weir crest level, or has openings at that level and an additional opening at a lower level controlled by a valve.

Sometimes heavy cast-iron pipes, for both delivery and waste purposes, are laid in the earthwork instead of in sluices, in which case the puddle should be rammed around them with thoroughness. In this latter case they should be tested, in place, under water pressure before being covered. A suitable hand force-pump may be used to give the requisite pressure if not otherwise obtainable. Bell and socket pipes with driven lead joints are used in such cases, and projecting *flanges* are cast around the pipes at intervals.

The method of laying and protecting discharge pipes, as shown in Fig. 60 (p. 84), has been adopted by the writer in several instances with very satisfactory results. A foundation of masonry is built up from a firm earth stratum to receive the pipes, and then when the pipes have been laid and tested, they are covered with masonry or concrete. In such case the sides of the masonry are not faced, and pointed, or plastered, but the stones are purposely left projecting and recessed, and the covering stones are of unequal heights, making irregular surfaces. This method is more economical in construction, and attains its object more successfully than the faced *break-walls* sometimes projected from the sides of gate-chambers and sluices.

The puddle or core material is rammed against the masonry in all cases, so as to fill all interstices solid. This portion of the work demands the utmost thoroughness and faithfulness; and with such, the structure will be so far reliable, and otherwise may be uncertain.

369. Gate Chambers.—When an impounding reservoir is deep, requiring a high embankment, it is advisable to place the effluent chamber upon one side of the valley toward the end of the embankment, with the effluent pipes for ordinary use only as low as may be necessary to draw

the lake down to the assumed low water level, as in Fig. 63, showing the inside slope of an embankment.

A waste-pipe for drawing off the lowest water is, in such case, extended from the front of the effluent chamber, sideways down the slope and side of the valley to the bed of its old channel, and is fitted with all details necessary for it

FIG. 63.

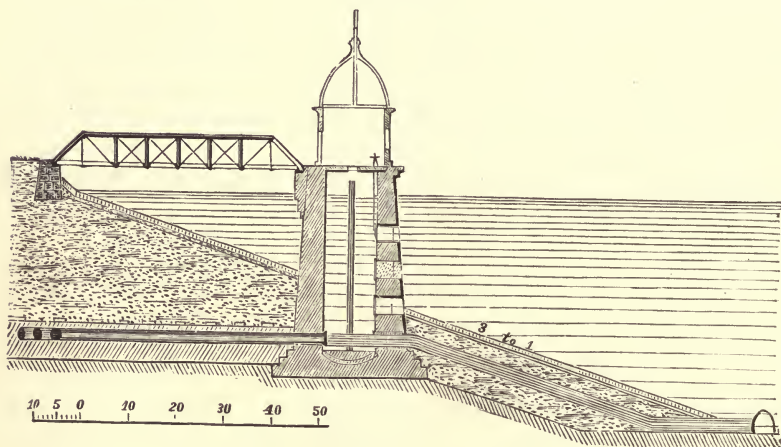

EFFLUENT CHAMBER AND SIPHON WASTE.

to perform the office of a siphon when there shall be occasion to draw the reservoir lower than the level of the gate chamber floor. By such arrangement the pipes may pass through the embankment, or through a sluice or tunnel in the side of a hill at a level twenty or twenty-five feet above the bed of the valley.

When a valve-chamber is built up from the inner toe of the embankment, so that the water surrounds it at a higher level, provision must be made for the ice-thrust, lest it crowd back toward the embankment the upper portion sufficiently to make a crack in the wall; and precaution must also be taken to prevent the ice lifting bodily the whole top of the

chamber when the water rises in winter, as it usually does in large storage reservoirs.

The writer has usually connected the gate-house with the embankment by a solid pier, when there would otherwise be opportunity for the ice to yield behind the chamber by slipping up the paving, as it expanded, and thus endanger the gate-chamber masonry.

There are inlets through the front of the effluent chamber shown in Fig. 63, at different depths, permitting the water to be drawn at different levels.

These, when the volume of water to be delivered is small, may be pieces of flanged cast-iron pipe built into the masonry, with stop-valves bolted thereon, but usually are rectangular openings with cast-iron sluice-valves and frames (Fig. 64) secured at their inside ends. The seat and bearing of the valves are faced with a bronze composition, which is planed and scraped so as to make water-tight joints. The screw-stem of the valve is also of composition, or aluminum or manganese bronze.

If such a valve exceeds 2'-3" \times 2'-9" in area, or is under a pressure of more than twenty feet head, some form of geared motion is usually necessary to enable a single man to start it with ease.

It is usually advisable to increase the number of valves rather than to make any one so large as to be unwieldy in the hands of a single attendant, even at the expense of some frictional head.

The stem of the small valves usually passes up through a pedestal resting on the floor of the chamber, and through a nut in the centre of a hand-wheel that revolves upon the pedestal.

The outside edge of each valve-frame should be so formed that a temporary wood stop-gate might be easily fitted

against it by a diver, in case accident required the removal of the valve for repairs. The chamber might then be readily emptied and the valve removed, without drawing down the lake.

Upon the back of the valve (Fig. 64) are lugs faced with bronze, and upon the frame corresponding lugs, both being arranged as inclined planes, and their office is to confine the valve snug to its seat when closed.

If the valve is secured to the side of the opening opposite to that which the current approaches, or to the pressure, its bolts must enter deep into or pass through the masonry.

FIG. 64.

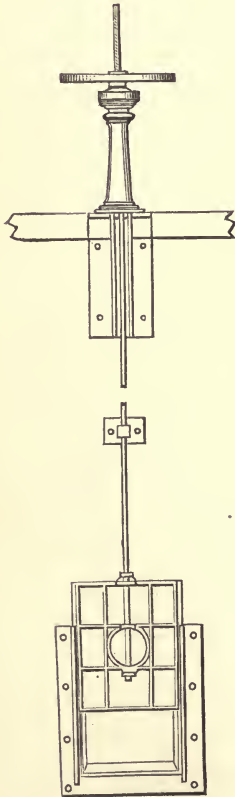

IRON SLUICE-VALVE.

A slight flare is usually given to the sluice-jambs, from the sluice-frame outward.

370. Sluice-Valve Areas.—When the head is to be rigidly economized, the submerged sluice-valve area must be sufficient to pass the required volume of water at a velocity not exceeding about five lineal feet per second; when the loss of head due to passage of the valve will not exceed about one-half foot.

If Q is the maximum volume, in cu. ft. per second; S , the area of the sluice in square feet; v , the assumed maximum velocity; then

$$Q = cSv, \quad (1)$$

in which c is a coefficient of contraction, that may be taken, for a mean, as equal to .70 for ordinary chamber-sluices.

From this equation of Q , we derive that of area,

$$S = \frac{Q}{cv}. \quad (2)$$

Let $Q = 70$ cubic feet per second; $v = 5$ lineal feet per second; then we have $\frac{Q}{cv} = 20$ square feet area, and we may make the valve opening, say $4' \times 5'$.

If there are a number of valves, whose respective areas are $s_1, s_2, s_3 \dots s_n$, then

$$\frac{Q}{cv} = s_1 + s_2 + s_3 \dots + s_n, \quad (3)$$

or advisedly we should give a slight excess to the sum of areas and make $s_1 + s_2 + s_3 \dots + s_n > \frac{Q}{cv}$.

371. Stop-Valve Indicator.—When a stop-valve is used, instead of a sluice-valve whose screw rises through the hand-wheel, it is usually desirable to have some kind of an indicator to show how nearly the stop-valve is to full open.

Fig. 65 illustrates such an indicator attached to the hand-wheel standard, as manufactured by the Ludlow Valve Co., at Troy, N. Y. A worm-screw upon the valve-stem revolves the indicator-wheel at the side of the standard, and indicates the various lifts of the valve between shut and full open.

372. Power Required to Open a Valve.—The theoretical computation of the power required to start a

FIG. 65.

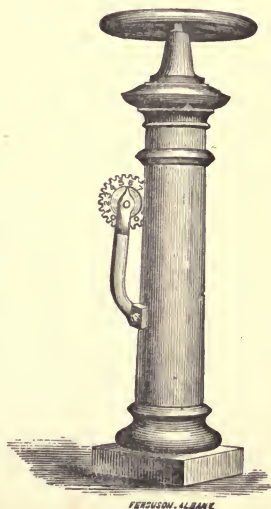

FERGUSON, ALBANY

closed valve, when it is pressed to its seat by a head of water upon one side and subject only to atmospheric pressure on the other side, is attended with some uncertainties; nevertheless this computation, subject to such coefficients as experience suggests, is a valuable aid when proportioning the parts of new designs.

Take the case of the metal sluice-valve, Fig. 64, raised by a screw, with its nut placed between collars in the top of a pedestal, and revolved by a hand-wheel, and let the centre of water pressure upon the valve be at a depth of 30 feet. Let the size of valve-opening be 2'-6" \times 2'-9", the pitch of the screw .75 inch, and the diameter of the hand-wheel 30 inches.

The weight has to slide along the spiral inclined plane of the screw, but its actual advance is in a vertical line, the pitch distance, for each revolution of the screw.

The power is applied to the hand-wheel, which is equivalent to a lever of length equal to its radius, moving through a horizontal distance equal to the circumference of its circle ($=$ radius \times 6.283) and a vertical distance equal to the pitch of the screw.

FIG. 66.



The distance d , moved through by the power in each revolution, is the hypotenuse bc , Fig. 66, of an angle whose base, ab , equals the circumference of its circle, and whose perpendicular, ac , equals the pitch of the screw $= \sqrt{\text{circumference}^2 + \text{pitch}^2} = d$.

Let w be the weight in lbs.; p the pitch, in inches; d the distance moved by the power per revolution, in inches, and P , the power, in foot-pounds..

According to a theory of mechanics, the

Vel. of Power : Vel. of Weight :: Weight : Power ; or,
 d : p :: w : P .

The *weight*, in this case, includes the actual weight of the iron valve and its stem ; its friction upon its seat due to the pressure of water upon it ; the friction of the screw upon its nut, and the friction of the nut upon its collar. These we compute as follows :

Weight of valve, assumed	=	300 lbs.
Friction of valve (15469 lbs. pres. \times coef. .20)	=	3094 "
Friction of screw (300 + 3094) \times coef. 20	=	679 "
Friction of nut (300 + 3094) \times coef. 15	=	501 "
Total equivalent weight, w	=	4574 "
Distance of power, $d = \{ \text{circum.}^2 \div \text{pitch}^2 \}^{\frac{1}{2}}$	=	94.25 inches.
Pitch	=	.75 "

In the form of equation,

$$P = \frac{wp}{d} = \frac{4574 \times .75}{94.25} = 36.4 \text{ lbs.} \quad (4)$$

Theoretically, this power applied at the circumference of the hand-wheel would be just upon the point of inducing motion, or if this power was in uniform motion around the screw, it would just maintain motion of the weight. The theory here admits that the screw and nut are cut truly to their incline, and that there is no binding between them due to mechanical imperfection.

When two metal faces remain pressed together an appreciable length of time, the projections of each enter into the opposite recesses of the other, to a certain extent. These projections of the moving weight must be lifted out of lock, and the inertia of the weight must be overcome before it can proceed. Metal valves usually drop against an inclined wedge at their back that presses them to their seat, and there is also a fibre lock with this wedge, or "stick," as it

is commonly called, according to the force with which the valve is screwed home.

Hence, the power required to *start* a valve is often double or treble, or even quadruple that ^{which} ~~that~~ would theoretically be required to maintain it in motion the instant after starting. The equation for starting the valve in such case may become,

$$\frac{4wp}{d} = P. \quad (5)$$

The computed distance which the power moves per revolution (94.25 inches) equals 7.854 feet, and the computed power 36.4 lbs. If twenty revolutions of the hand-wheel are made per minute, then the power exerted is theoretically 7.854 ft. \times 20 rev. \times 36.4 lb. = 5717.7 foot-pounds per minute. This is a little more than one-sixth of a theoretical horse-power.

If, for the hand-wheel, which revolves the nut, there is substituted a spur-gear of equal pitch diameter, and into this meshes a pinion of one-third this diameter, and the same hand-wheel is placed upon the axle of the pinion, then the new power required will be reduced proportionally, as the square of diameter of the pinion is reduced from the square of diameter of the spur, or in this case, one-ninth.

373. Adjustable Effluent Pipe. — An adjustable effluent pipe, capable of revolving in a vertical plane, and connected directly to the main supply pipe,* is shown in Fig. 60 (p. 84).

This adjustable pipe is constructed of heavy sheet copper, and is sixteen inches in diameter. Upon its end is a

* This ingenious form of flexible joint was suggested to the writer by Hon. Alba F. Smith, one of our most able American mechanical engineers. Mr. Smith designed this joint many years ago, and used it at watering stations upon the Hudson River, and other railroads under his charge.

perforated bulb, through which the water enters the pipe. The movable section of the pipe is counter-weighted within the chamber, so the bulb can be set at any desired depth in the water, or raised out of water to the platform upon the chamber, for cleaning, expeditiously and easily by a single attendant. This arrangement has operated most satisfactorily during the eight years since its completion, and delivers the water supply for about 18,000 inhabitants.

Equivalent devices have been adopted in several instances in Europe and in India, and they are especially applicable to cases where the impounding reservoirs are also the distributing reservoirs, without the intervention of filtering basins, and to cases where the surface fluctuates frequently, rapidly, or to a considerable extent.

When a sudden or considerable decrease of the temperature of the air chills the quiet reservoir water surface, and thus induces a vertical motion in, or shifting of position of the whole mass of water, the bulb may be made to follow the most wholesome stratum.

If the impounded water is to be led to filter-beds or to one or more distributing reservoirs, then the discharge-pipes lead directly from the effluent chamber.

374. Fish Screens.—In the chamber, Fig. 67, is shown a set of fish-screens, arranged in panels so as to slide out readily for cleaning. The finer ones of the double set are of No. 15 copper wire, six meshes to the inch, and the coarser ones of No. 12 copper wire, woven as closely as possible.

Figs. 67 and 68 show a plan of and a vertical section through an influent chamber of a distributing reservoir.

The pipes *d d* deliver water from the impounding reservoir, or may be force mains, leading from pumping engines to the chamber *A*. The main chamber is divided in two

FIG. 67.

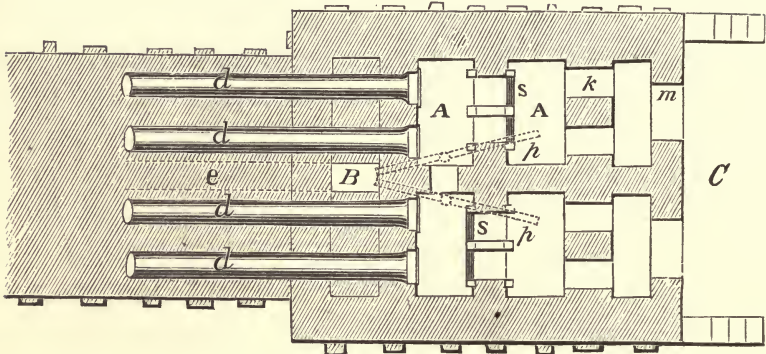

PLAN OF INFLUENT CHAMBER.

parts, for convenience in management when there are several delivery pipes. There are sluices *k k*, controlled by valves, through which the water may be admitted to the reservoir *C*. There is also a weir, *i*, over which water may be passed, instead of through the sluices.

FIG. 68.

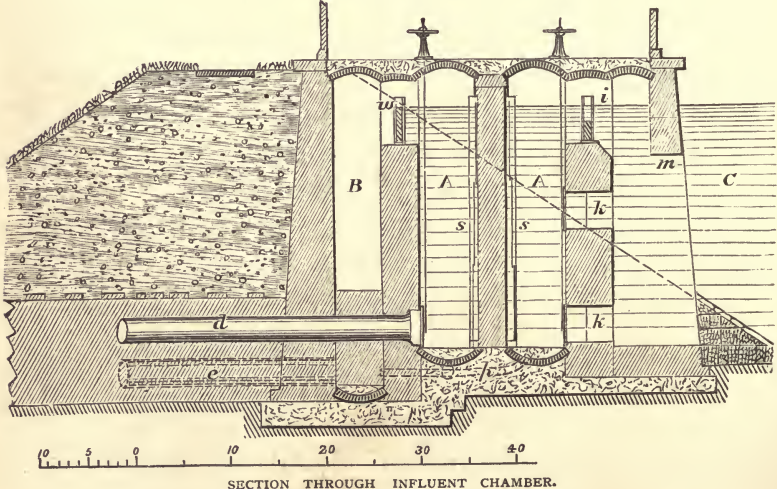

SECTION THROUGH INFLUENT CHAMBER.

Grooves are prepared in each section of the main chamber for a double set of screens, *ss*.

B is a waste chamber, and e a waste pipe, and w a waste overflow weir.

A frost curtain, m , is placed in front of the inflow weir, to prevent the water surface in the chamber from freezing, if the pumps are not in operation during winter nights.

There are drain pipes, p , leading from the sections of the main chamber to the waste well.

In the dividing partition is a sluice, with valve so that the whole chamber may be connected as occasion requires.

A distributing reservoir effluent chamber might be similar to the above, omitting the waste chamber, weirs, and frost curtain; the direction of the current would in this case be reversed, of course.

In the effluent chamber of the reservoir shown in Fig. 58, a check-valve is placed in the effluent pipe, so that when the pumps are forcing water into the distribution pipes around the reservoir, with direct pressure, the water will not return into the reservoir by the supply main.

375. Gate-Chamber Foundations.—Gate-chambers built into the inner slope of an earthwork embankment will introduce an element of weakness at that point, unless intelligent care is exercised to prevent it.

Any after settlement along the sides of the foundation or walls of the chamber separates the earth from the masonry, leaving a void or loose materials along the side of the masonry, which permits the water of the reservoir to percolate along the side to the back of the chamber, under the full head pressure.

The stratum of earth on which the foundation rests should be not only impervious, but so firm, or made so firm, that no settlement of the foundation can take place. If the chamber is high and heavy, the footing courses should be extended on each side so as to distribute the

weight on an area of earth larger than the section of the chamber.

The foundation of the chamber is to be water-tight, and capable of resisting successfully the upward pressure upon its bottom due to the head of water in the reservoir, when the chamber is empty.

376. Foundation Concrete.—The use of *beton*, or hydraulic concrete, is often advisable for the bed-course of a valve-chamber foundation, to aid in distributing the weight of the structure and in securing a water-tight floor. The composition of the concrete is to be proportioned for these especial objects. Concrete for a revetment, demands weight as a special element; for a lintel, tensile strength; for an arch, compressile strength; but for the submerged foundation of a gate-chamber, *imperviousness*, which will ensure sufficient strength.

The volume of cement should equal one and one-third times the volume of voids in the sand. The volume of mortar should equal one and one-third times the volume of voids in the coarse gravel or broken stone. The cement and sand should be first thoroughly mixed, then tempered with the proper quantity of water equally worked in, and then the mortar should be thoroughly mixed with the coarse gravel or broken stone, which should be clean, and evenly moistened or sprinkled before the mortar is introduced. None of the inferior cement so often appearing in the market should be admitted in this class of work. Good hydraulic lime may in some cases be substituted for a small portion of the cement, say one-third.

The concrete should be rammed in place, but never by a process that will disturb or move concrete previously rammed and partially set. A very moderate amount of water in the concrete suffices when it is to be rammed.

377. Chamber Walls.—Fine-cut beds and builds, hammered end joints, and coursed work, in chamber masonry, make expensive structures, but even such work is hardly made water-tight by a poor or careless mechanic. A great deal of skill and care must be brought into requisition to make a rubble wall water-tight.

Imperviousness is here, again, a special object sought. That a wall may be impervious, its mortar must be impervious; its voids must be compactly filled, every one; its stones must be cleaned of dust, moistened, laid with close joints, and well bedded and bonded; and no stone must be shaken or disturbed in the least after the mortar has begun to set around it.

Stone must not be broken or hammered upon the laid wall, or other stones will be loosened. Stones should be so lewised or swung that the bed or joint mortar shall not be disturbed when the stone is floated into place.

The plan occasionally adopted of grouting several courses at the same time with thin liquid grout, might answer in a cellar wall when the object was to prevent rats from perambulating through its centre, but it is unreliable in a chamber or tank-wall intended to resist percolation under pressure. Skillful workmanship, in hydraulic masonry, is cheaper than expensive stock.

CHAPTER XVII.

OPEN CANALS.

378. Canal Banks.—The stored waters of an impounding reservoir are sometimes conveyed in an open canal toward the distributing reservoir, or the city where they are to be consumed, or for the purposes of irrigation. The theory of flow in such cases has been already discussed (Chap. XV).

The subsoils over which the canal leads require careful examination, and if they are at any point so open and porous as to conduct away water from the bed of the canal, the bed and sides must be lined with a layer of puddle protected from frost, as in Fig. 69, showing a section of a puddled channel in a side-hill cut.

FIG. 69.

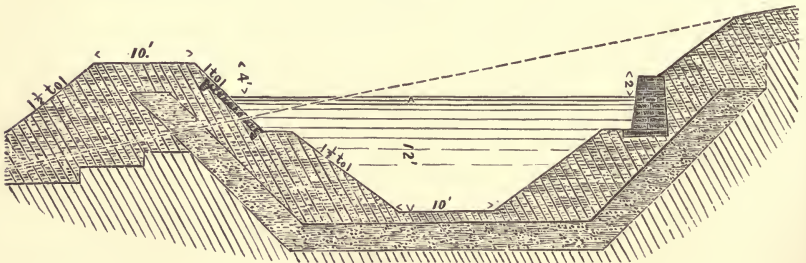

PUDDLED CHANNEL BANK.

The retaining channel bank on the down-hill side is constructed upon the same principles as a reservoir embankment (§ 351), the chief objects being to secure solidity, imperviousness, and permanence.

A longitudinal drain along the upper slope of side-hill sections will prevent the washing of soil into the canal. The water slopes will require revetments or paving from three feet below low-water to two feet above high-water line, and paving or rubbling down the entire slope at their concave curves.

Substantial revetments or pavings of sound stone are the most economical in the end.

Revetments, built up of bundles of fascines laid with ends to the water and each layer in height falling back with the slope line, have been used to some extent on the banks of canals of transport, and on dykes.*

If the slopes are rip-rapped, or pitched with loose stone, the slopes must be sufficiently flat, so the waves and the frost will not work the stones down into the water, and demand constant repairs.

The retaining canal banks of the head races of water-powers have sometimes a longitudinal row of jointed-edged sheet-piles through their centre. The selected mixed earth is compactly settled on both sides of this piling, as shown in Fig. 70. Such piling tends to insure im-

perviousness, prevent vermin from burrowing through the bank, and lasts a long time in compact earth.

379. Inclinations and Velocities in Practice.—The unrevetted trapezoidal canals in earthwork, for water-

* *Vide* illustration of Foss Dyke in Stevenson's Canal and River Engineering, p. 18, Edinburgh, 1872; and Mississippi River Dyke at Sawyer's Bend. Report Chief of U. S. Engineers, June 30, 1873.

FIG. 70.

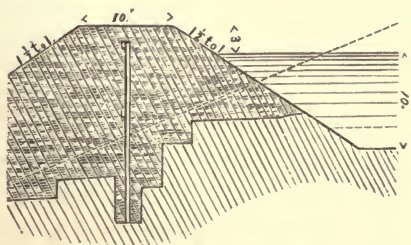

SHEET-PILED CHANNEL BANK.

supplies, irrigation, and for hydraulic power, except in water-powers of great magnitude, have sectional areas, respectively, between 500 and 50 square feet limits, and hydraulic mean radii between 7 and 2.5.

In such canals the surface velocities range between 5 feet and 2 feet per second, and the inclinations of surface between .75 feet (= .000104) and 3.5 feet (= .000663) per mile.

Practice indicates that the favorite surface velocity of flow, in such straight canals, is about 2.5 feet per second, in canals of about five feet depth, being less in shallower canals, and increased to 3.5 feet per second in canals of nine feet depth.

Only very firm earths, if unprotected by paving or rubble, will bear greater velocities without such considerable erosions as to demand frequent repairs.

Burnell states* that the inclinations given to the recently constructed irrigation canals in Piedmont and Lombardy, varies from $\frac{1}{1600}$ (= .000625) to $\frac{1}{3600}$ (= .000278); but that inclinations frequently given to main conductors in the mountainous districts of the Alps, Tyrol, Savoy, Dauphiné, and Pyrenees, is $\frac{1}{500}$ (= .002).

380. Ice Coverings.—The maximum winter flow having been determined upon, the sectional area, beneath the thickest formation of ice at the lowest winter stage of water, must be made ample to deliver this maximum quantity of water, and the influence of the increase of friction on the ice perimeter over that on the equal air perimeter must be duly considered.

381. Table of Dimensions of Supply Canals.—The dimensions and inclinations of a few well-known canals

* Rudiments of Hydraulic Engineering, p. 127. London, 1858.

are given as illustrative of the general practice in various parts of the world, relating especially to *water supply* and *irrigation*.

TABLE No. 79.

DIMENSIONS OF WATER SUPPLY AND IRRIGATION CANALS.

	FORM.	BOTTOM WIDTH.	SIDE SLOPE.	DEPTH, AT CENTRE.	INCLINATION.	RATIO OF INCLINATION.	MEAN VELOCITY.
Henares Canal, Spain.....	Trapezoidal.	8.23	1½ to 1	4.92	1 in 3067	.000326	2.296
Roquefavour Canal, France...	"	9.84	1½ to 1	4.92	1 in 3333	.0003	...
Marseilles " " ...	"	9.84	1½ to 1	5.58	1 in 3000	.000333	2.72
Ourcq " " " ...	"	11.48	1½ to 1	4.92	1 in 9470	.0001056	...
Montreal W. W. (old), Canada.	"	20	1¼ to 1	8	1 in 25000	.00004	...
" " (new), " "	"	78	2 to 1	14	1 in 25000	.00004	...
Manchester, N.H., W.W., U.S.	"	6	1 to 1	14	1 in 5280	.000189	...
	"	150	9
Ganges Canal, India... ..	and part Twin Rect.	85	0	3.7
Glasgow W. W., Scotland....	Rectangular.	8	0	1 in 6325	.000158	1.478
Cavour Canal, Italy.....	"	131	6.1	1 in 2800	.000357	2.6
	"	60	11.15	1 in 4000	.00025	

In the numerous shallow irrigation canals of Spain, Italy, and northern India, a mean velocity as great as three feet per second is necessary to prevent a luxuriant growth of weeds on the bottoms and side slopes, which reduce the effective sectional area of the canal, and consequently the volume of water delivered.

382. Canal Gates.—Fig. 71 is a half elevation of the gates in the Manchester, N. H., water-works canal, showing also a profile of the canal beyond the wing walls of the gate abutments.

This canal leads the water from Lake Massabesic to the turbines and pumps at the pumping station.

The water surface rises and falls with the lake, which has a maximum range of five feet, so that the turbines are constantly under the full head of the lake. The canal is sixteen hundred feet long, and has similar gates at its

entrance and at the head of the turbine penstock. The entrance gates are provided with a set of iron racks to intercept floating matters that might approach from the lake, and the penstock gates are provided with a set of fine mesh copper-wire fish-screens.

There are four gates in each set, each 3 feet wide and 5 feet high. On the top of each gate is secured a cast-iron

FIG. 71.

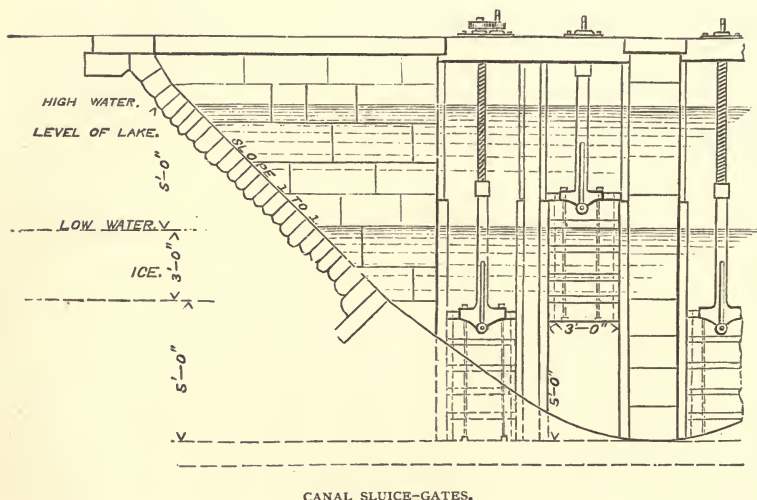

tube containing a nut at its top. Over each tube is fastened, to a lintel, a composition screw, working in its nut, which raises or lowers its gate.

Two gates in each set have their screws provided with gears and pinions. The pinions, or screws, are turned by a ratchet wrench, so the operator may turn them either way, to raise or lower the gate, by walking around the screw, or by a forward and backward motion of the arms.

The floor covering the gate-chamber is of tar-concrete resting upon brick arches.

When large sluices are necessary, a system of worm gearing is usually applied for hoisting and lowering the gates. These gears may be operated by hand-power, or may be driven by the belts or gears upon a counter-shaft, which is driven by a turbine or an engine.

Canals leading from ponds subject to floods or sudden rise above normal level, are to be provided with waste-weirs near their head gates, and with waste-gates, so their banks will not be overtopped or their waters rise above the pre-determined height.

Stop-gates are placed at intervals in long water-supply and irrigation canals, with waste-gates immediately above them for drawing off their waters, to permit repairs, or for flushing, if the waters deposit sediment.

Culverts are sometimes required to pass the drainage of the upper adjoining lands beneath the canal, and these may be classed among the treacherous details that require exceeding care in their construction to guard against settlements, and leakage of the canal about them.

383. Miners' Canals.—The sharp necessities of the gold-mining regions of California and Nevada have led to some of the most brilliant hydraulic achievements of the present generation. The miners intercept the torrents of the Sierras where occasion demands, and contour them in open canals, along the rugged slopes, hang them in flumes along the steep rock faces, syphon them across deep canyons, and tunnel them through great ridges, in bold defiance of natural obstacles, though constant always to laws of gravity and equilibrium.

The force of water is an indispensable auxiliary in surface mining, and capital hesitates not at thirty, fifty, or a hundred miles distance, or almost impassable routes, when the torrent's power can be brought into requisition. A

hundred *ditches*, as the miners term them, now skirt the mountains, where but a few years ago there was no evidence that the civilization or energy of man had ever been present.

The Big Canyon Ditch, near North Bloomfield, Nevada, for instance, is forty miles long and delivers 54,000,000 gallons of water per day. The sectional area of the stream is about 33 square feet, and the inclination 16 feet to the mile. Its flumes are 6 feet wide with grade of one-half inch in twelve feet, or about 18 feet to the mile. The contour line of the canal is from 200 to 270 feet above the diggings, to which its waters are led down in wrought-iron pipes.

With a terrible power, fascinating to observe, its jets dash into the high banks of gravel, rapidly under-cutting their bases, and razing them in huge slides that flow down the sluice-boxes with the stream.

Thus, in a single mine, 30,000 cubic yards of gravel melt away in a single day, under the mighty hydraulic influence that has been gathered in the torrent and canaled along the eternal hills.

The Eureka Ditch, in El Dorado County, is forty miles long, and there are many others of great length, whose magnitude and mechanical effect entitle them to consideration, as valuable hydraulic works, and monuments of hardy enterprise.

The Eureka embankment is seventy feet in height, flows two hundred and ninety-six acres, and is located six thousand five hundred and sixty feet above the level of the sea.

CHAPTER XVIII.

WASTE-WEIRS.

384. The Office and Influence of a Waste-Weir.

—An ample waste-weir is the safety-valve of a reservoir embankment.

The outside slope of an earth embankment is its weakest part, and if a flood overtops the embankment and reaches the outer slope, it will be cut away like a bank of snow before a jet of steam.

The overfall should be maintained always open and ready for use, independent of all waste sluices that are closed by valves to be opened mechanically, for a furious storm may rage at midnight, or a waterspout burst in the valley when the gate-keeper is asleep.

Data relating to the maximum flood flow is to be diligently sought for in the valley, and the freshet marks along the watercourse to be studied. The overfall is to be proportioned, in both dimensions and strength, for the extraordinary freshets, which double the volume of ordinary floods, and if there are existing or there is a probability of other reservoirs being built in the valley above, it may be wise to anticipate the event of their bursting, especially if an existing reservoir dam is of doubtful stability.

A short overfall may increase or affect the damage by flood flowage to an important extent, and makes necessary the building of the embankment to a considerable height above its crest level; while, on the other hand, a long overfall, if exposed to the direct action of the wind, may permit

too great a volume of water to be rolled over its crest in waves just at the commencement of a drought, when it is important to save, to the uttermost gallon. Such wave action, under strong winds, might draw down a small reservoir several inches, or even a foot below its crest, unless such contingency is anticipated and guarded against. Strong winds blowing down a lake often heap up its waters materially at the outlet, and increase the volume of waste flowing over its weir or outfall.

An injudicious use of *flash-boards* upon waste-weirs has in many instances led to disastrous results. In all cases, a maximum flood height of water should be determined upon, and then the weir dimensions be so proportioned that no contingency possible to provide for shall raise the water above the predetermined height. The length of the overfall and volume of maximum flood-flow govern the distance the highest crest-level must be placed below the maximum flood-level. Flash-boards may in certain cases, and in certain seasons, be serviceable in governing the level of water *below or just at the crest line*, especially when there are low lands, or *lands awash*, as they are termed, bordering upon the reservoir, with their surfaces not exceeding three feet above the crest line.

Several English writers mention that a general rule for length of waste-weir, accepted in English practice, is to make the waste-weir three feet long for every 100 acres of watershed. This rule will apply for watersheds not exceeding three square miles area, but for larger areas gives an inconvenient length.

385. Discharges over Waste-Weirs.—Having determined, or assumed from the best data available, the maximum flood-flow which the overfall may have to discharge, if a very heavy storm takes place when the reservoir

is full, the overfall is then to be proportioned upon the basis of this flow.

For the calculation of discharge, the overfall may be considered to be a species of measuring-weir (§ 303), and subject to certain weir formulas.

If there are flash-boards, with square edges, forming the crest, then, for depths of from nine inches to three feet, Mr. Francis' formula may be applied with approximate results, and we have the discharge :

$$Q = 3.33 (l - 0.1nH) H^{\frac{3}{2}}, \quad (1)$$

in which Q is the volume of discharge, in cubic feet per second ; H , the depth of water upon the crest, measured to the lake surface level ; l , the clear length of overfall ; and n the number of end contractions.

We have seen (§ 309) that the velocities of the particles flowing over the crest are proportionate to the ordinates of a parabola, and that the mean velocity is equal to two-thirds the velocity of the lowest particles ; hence we have the mean velocity, v , of flow over the crest,

$$v = \frac{2}{3}\sqrt{2gH} = 5.35\sqrt{H}. \quad (2)$$

Multiplying the depth of water H upon the weir, into the length l of the weir, and into the mean velocity v , we have the volume of discharge, when there are no intermediate flash-board posts :

$$Q = mlH \times \frac{2}{3}\sqrt{2gH} = 5.35mlH^{\frac{3}{2}}, \quad (3)$$

in which m is a coefficient of contraction (§ 312), with mean value about .622 for sharp-edged thin crests.

By transposition, we have :

$$H = \left\{ \frac{Q}{\frac{2}{3}ml\sqrt{2g}} \right\}^{\frac{2}{3}}. \quad (4)$$

If the overfall has a wide crest similar to that usually given to masonry dams, Fig. 47, then we may apply more

accurately the formula suggested by Mr. Francis for such cases, viz. :

$$Q = 3.012lH^{1.53} \quad *$$
(5)

If we desire to know the depth of discharge for a given volume and weir length, then, by a transposition of this last formula, we have :

$$H = \left\{ \frac{Q}{3.012l} \right\}^{\frac{1}{1.53}}$$
(6)

A few approximate values of Q , for given values of H , are given in the following table, to facilitate preliminary calculations.

TABLE No. 80.

WASTE-WEIR VOLUMES PER LINEAL FOOT FOR GIVEN DEPTHS.

H .	$Q = 5.35mH^{\frac{3}{2}}$.	$Q = 3.012lH^{1.53}$.
<i>In feet.</i>	<i>In cu. ft. per sec.</i>	<i>In cu. ft. per sec.*</i>
.50	1.043	1.177
.75	1.939	2.167
1.00	3.012	3.339
1.25	4.238	4.670
1.50	5.602	6.134
1.75	7.093	7.625
2.00	8.699	9.430
2.25	10.415	11.244
2.50	12.238	13.167
2.75	14.159	15.193
3.00	16.171	17.309
3.50	21.2
4.00	26.5
4.50	32.3
5.00	38.6
5.50	45.0
6.00	52.0
6.50	60.0
7.00	68.3
7.50	78.0
8.00	87.0

* In this column m increases from .563 for 1 foot depth to .670 for 8 feet depth, but the values of m for depths exceeding 3 feet have not been determined by experiment, and their results are subject to some uncertainty.

386. Required Length of Waste-Weirs.—The following table, prepared to facilitate preliminary calculations, gives estimated flood volumes of waste from *small* impounding reservoirs, in ordinary Atlantic slope basins, for watersheds of given areas ; also the length of waste-weir required, and approximate depth of water on the crest of the given length :

TABLE NO. 81.

LENGTHS AND DISCHARGES OF WASTE-WEIRS.

Area of Watershed.	Required length of overfall for given watershed.	Approx. depth of water on overfall of given length.	Approx. discharge per lin. ft. of given overfall, for given depth.	Flood volume from whole area, $Q = 200 (M)^{\frac{3}{2}}$.
<i>Square miles.</i>	<i>Feet.</i>	<i>Feet.</i>	<i>Cubic feet.</i>	<i>Cubic feet per sec.</i>
1	25	1.89	8.00	200
2	32	2.35	11.13	356
3	39	2.56	12.82	500
4	44	2.76	14.43	635
6	54	3.01	16.56	890
8	61	3.22	18.54	1131
10	68	3.46	20.04	1363
15	83	3.70	23.01	1910
20	95	3.90	25.56	2428
25	105	4.14	27.85	2925
30	116	4.28	29.35	3404
40	133	4.58	32.53	4326
50	149	4.71	34.95	5208
75	183	5.14	39.92	7304
100	212	5.34	43.78	9282
200	295	6.28	56.08	16542
300	360	6.65	64.42	23190
400	400	7.36	73.70	29480
500	440	7.81	80.70	35500
600	480	7.98	86.08	41320
800	530	8.86	99.09	52520
1000	580	9.32	109.07	63260

The maximum flood, and consequently the required length of overfall, or depth upon it, varies with the maximum periodic rainfall ; the inclination and porosity of

soils; the sum of pondage surfaces; and to some extent with temperatures.

The above estimated flood volumes refer to ordinary American Atlantic slopes, and forty to fifty inch mean annual rainfalls, and to streams with comparatively small pondage areas.

The above tabled lengths of overfalls or range of depths upon crests of waste-weirs, are to be increased for *flashy* streams, and may be reduced for *steady* streams with large or many small ponds.

The increase of pressure upon all portions of the embankment and foundation, and upon the waste-weir, by the flood rise, must be fully anticipated in the original design of the structure.

387. Forms of Waste-Weirs.—Fig. 72 illustrates a waste-weir placed in the centre of length of an earthwork embankment, retaining a storage lake of twenty-four hundred acres, and the drainage of forty square miles of watershed.

FIG. 72:

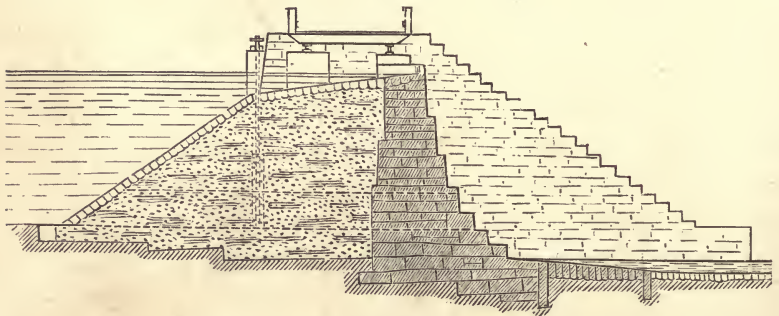

WASTE-WEIR.

The down-stream face of the weir is constructed in a series of steps of decreasing height and increasing projection, from the crest downward, so that the edges of the steps nearly touch an inverted parabolic curve.

The apron receiving the fall of waste water from the crest of the weir is of rubble masonry, and contains two upright courses intended to check any scour from the "undertoe" during freshets, and also to lock the foundation courses that receive the heaviest shocks of the falling water.

The projection of the steps was arranged to break up the force of the falling water as much as possible.

The fall from crest to apron is twenty-five feet, and the flood depth upon the weir twenty inches; yet the force of the falling water is so thoroughly destroyed that it has not been sufficient to remove, in three years service, the coarser stones of some gravel carted upon the apron during construction of the upper courses of the weir.

There is a 3 by 5 feet waste-slucice through the weir at one end, discharging upon the apron. In front of the slucice the apron consists of two eighteen-inch courses of jointed granite upon a rubble foundation, doweled and clamped together in a thorough manner.

A carriage-bridge spans the weir, and rests upon the wing walls and three intermediate piers built upon the weir.

388. Isolated Weirs.—Where the topography of the valley admits of the waste-weir being separated from the embankment, it should be so placed at a distance, and it is often conveniently made to discharge into a side valley where the flowage nearly, or quite, reaches a depression in the dividing ridge.

But it is not always admissible to so divert the water, as riparian rights may be affected, or flood damages be created on the side stream.

When possible, it is advisable to locate the waste-weir upon a ledge at one end of the embankment, so that the fall from the crest will not exceed three or four feet.

There should be a fall of at least three feet from the crest, as in such case a less length of weir will be required than if it slopes gently away as a channel.

FIG. 73

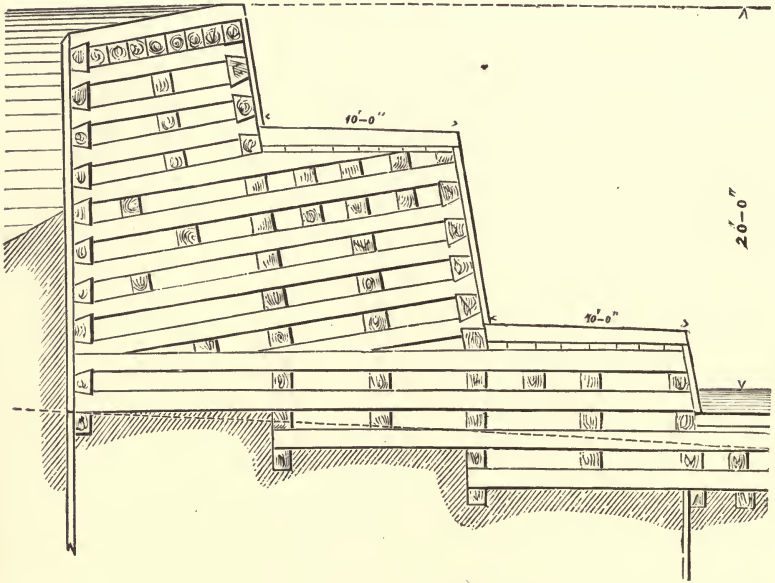

TIMBER CRIB-WEIR.

389. Timber Weirs.—In those localities where sound and durable building-stones are scarce, and timber is plenty and cheap, the waste-weir may be substantially constructed of timber in crib form. Fig. 73 represents such a weir placed upon a gravel foundation. The fall is twenty feet, and the face of the weir is divided into three benches so as to neutralize the force of the fall that in freshets, if vertical, would tend to excavate a hole in the gravel in front of the dam at least two-thirds as deep below the lower water surface as the height of the fall.

The timbers are faced upon two sides to twelve inches thickness and entirely divested of bark. The bed-sills are

sunk in trenches in the firm earth, and two rows of jointed sheet-piling are sunk, as shown, to a depth that will prevent the possibility of water working under them. Upon the bed-sills longitudinal timbers are laid five feet apart, then cross timbers as shown, and so alternately to the top. As each tier is put upon another it is thoroughly fastened to the lower tier by trenails or $\frac{7}{8}$ -inch round iron bolts. The bolts should pass entirely through two timbers depth and one-half the depth of the next tier, requiring for twelve-inch timbers 30-inch bolts.

As each tier is laid it should be filled with stone ballast and sufficient coarse and fine gravel puddled in to make the work solid, leaving no interstices by the side of or under timbers. The gravel should be rammed under the timbers so as to give them all a solid bearing.

A tier of plank is placed under each bench capping, and a tier of close-laid timbers is placed under the crest capping. The bench and crest cappings are of timbers jointed upon their sides and laid close. The upper and lower faces are planked tight with jointed plank.

A weir thus *solidly* and *tightly* constructed will prove nearly as durable as the best masonry structures. The capping and face plankings will be the only parts requiring renewal, and these only at intervals of a number of years if they are at first of proper thickness.

Similar forms of crib-work have been used with complete success on rock bottoms, on impetuous mountain streams, where they were subject to the shocks of ice at the breaking up of winter, and to great runs of logs in the spring. In such cases the bed-sills are bolted to the rocks.

Similar crib foundations may be used to carry masonry weirs upon gravel bottoms, but the crib-work should in such case be placed so low as to be always submerged.

Fig. 73 was designed for a case where the watershed is of about one hundred square miles area. Its crest-length is two hundred feet, and six feet is the estimated maximum flood-depth upon its crest.

390. Ice-thrust upon Storage Reservoir Weirs.—Those weirs that are located in Northern climates upon storage ponds, such as are drawn down in summer and do not rise to the crest-level until past mid-winter, should be backed with gravel to the level of the backs of their caps, and the gravel should be substantially paved, as in Fig. 72. Otherwise the expansion of the thick ice against the vertical backs of the weirs may act with such powerful thrust as to displace or seriously injure its upper portion.

391. Breadth of Weir-Caps.—The cap-stones of weirs in running streams should incline downward toward the pond side at least two inches for each foot of breadth, so that the floating ice and logs will not strike against their back ends when the water is flowing rapidly.

There is a lack of uniformity, in practice, in breadths of tops of waste-weirs, and the unsatisfactory working of the quarry from which the caps are supplied often controls this dimension so far as to reduce it to an unsubstantial measure.

The breadth of cap required depends somewhat on the pond behind the weir. If the pond is relatively broad and deep, water and whatever floating debris it carries, will approach the weir with a relatively low velocity. If the pond is small and the stream torrential, with liability of great depth upon the weir, then the cap-stones must have length and weight to resist the force of the current and impact of the floating bodies. Overfalls upon logging streams rising in the lumber regions, require particularly heavy caps, and the force of the logs or ice upon the caps will

usually be greater when the depth upon the weir is from one and one-half to two feet, than when deeper.

392. Thickness of Waste-Weirs and Dams.—If the back, or pond side of the dam, is vertical, and the thickness at cap constant, then the thicknesses at given depths may be found, for plotting a trial section, by the following equation :

Let b be the assumed top breadth, and t the thickness at any given depth, d , then

$$t = b + .1 d^{\frac{3}{2}}. \quad (7)$$

For illustration, let the assumed cap breadth, or length of cap stones, for a long straight dam, be eight feet, then for the following given depths, the ordinates or thicknesses are as follows :

TABLE No. 82.

THICKNESS FOR MASONRY WEIRS AND DAMS.

DEPTHS FROM TOP OF CAP.				THICKNESS.
<i>Feet.</i>	(<i>b.</i>)	($.1d^{\frac{3}{2}}$)	=	<i>Feet.</i>
0	8	0.0	=	8.00
4	8	.8	=	8.80
6	8	1.47	=	9.47
8	8	2.26	=	10.26
10	8	3.16	=	11.16
12	8	4.16	=	12.16
15	8	5.81	=	13.81
20	8	8.94	=	16.94
25	8	12.50	=	20.50
30	8	16.43	=	24.43
35	8	20.71	=	28.71
40	8	25.30	=	33.30
45	8	30.19	=	38.19
50	8	35.36	=	43.36

If the face curve is resolved into steps, as is advisable over gravel bottoms or tertiary rock, then the masonry of

the steps must be very heavy and substantial, in the high dams, to withstand for a long term of years the shock of the falling water.

393. Force of the Overflowing Water.—It is of the utmost importance that the water passing over the lip of a high dam shall reach the bed of the stream below the dam with the least possible shock to the foundation, even though it is of a tolerably hard rock, and especially if the apron be of concrete or crib-work.

The “life” of numerous upright-face dams has been materially shortened by the tremor due to the flood falls upon their foundations.

In the case of an overfall twenty-five feet high, with six feet depth of water above the crest, for instance, there is a force of nearly 80,000 pounds per second pounding upon each lineal foot of its apron, tending to shake the structure into granular disintegration, and making the earth tremble under the shock.

394. Heights of Waves.—Stevenson gives, in his treatise on Harbors, the following formula for computing the height of waves coming from a given exposure, or “fetch” of clear deep water:

$$H = 1.5\sqrt{D} + (2.5 - \sqrt[4]{D}), \quad (8)$$

in which H is the height of waves in feet, and D is the length of exposure or fetch in miles.

The numerical values of height of wave, according to this formula, for given exposures, are as follows:

TABLE No. 83.

HEIGHTS OF RESERVOIR AND LAKE WAVES.

Exposure, in miles.....	.25	.50	.75	1	1.5	2	3	5	10.
Height of wave, in feet..	2.543	2.756	2.868	3	3.031	3.332	3.782	4.437	5.466

When waves meet a paved slope their vertical longitudinal section is suddenly reduced and their velocity enhanced in inverse proportion. They will therefore rise up the slope to a vertical height much greater than the height of the approaching wave, which height will depend on both the initial velocity of the wave and the suddenness with which its sectional area is reduced.

CHAPTER XIX.

PARTITIONS, AND RETAINING WALLS.

395. Design.—The hydraulic engineer finds necessary exercise for his skill on every hand to adapt a variety of constructions in masonry to their several ends, in methods at once substantial and economical.

Designs are required for reservoir partitions and gate chambers that are to sustain pressures of water upon both sides, and either side alone; revetments for reservoirs, canals, and lake and river fronts that are to sustain pressures of water and earth upon opposite sides, and earth alone upon one side; coal-shed walls that are to sustain the pressure of coal, whose horizontal thrust nearly equals that of a liquid of equal specific gravity; conduit and filter gallery walls, that are to sustain pressures of earth and water and thrusts of loaded arches; basement walls and bridge abutments that are to sustain thrusts of earth and carry weight; wing walls of triangular elevations and varying heights, that are to sustain varying thrusts; and waste-weirs, that are to sustain pressures of water higher than their summits and moving with velocity.

Rule of thumb practice in such structures has led to many failures, when the amounts and directions of thrusts were not understood; and such failures have, on the other hand, led to the piling up of superfluous quantities of masonry, often in those parts of section where it did not increase the stability of position, but did endanger the stability of the foundations.

Good design only, unites economy with stability in masonry subjected to lateral thrusts.

396. Theory of Water Pressure upon a Vertical Surface.—The theory of pressure of water upon a plane surface, and of the stability of a vertical rectangular retaining wall, is quite simple, and is easily exemplified by graphic illustration, and by simple algebraic equations.

Let BD , Fig. 74, be a vertical plane, receiving the pressure of water.

The pressure, p , at any depth is proportional to that depth into the density of the fluid.

Let w_1 be the weight of one cubic foot of water = 62.5 lbs.; then the pressure upon any square foot of the vertical plane, whose depth of centre of gravity is represented by d , is $p = dw_1$.

Let the depth of the water B_2D be 12 feet = h . Plot in horizontal lines from B_2D , at several given depths, the magnitudes of the pressures at those depths = dw , as at ss_1 ; then the extremities of those lines will lie in a straight line passing through B , and cutting the horizontal line CDf , in f , Df being equal to the magnitude of the pressure at D .

The total pressure upon the plane B_2D , and its horizontal effects at all depths are graphically represented by the area and ordinates of the figure B_2fD .

In theoretical statics, the effect of a pressure upon a solid body is treated as a force acting through the centre of gravity of the body.

Consider the pressure of BfD to be gathered into its *resultant*, passing through its centre of gravity,* g . The

* To find the centre of gravity of a triangle BfD , draw a broken line from D , bisecting the opposite side in s_1 , and from f , bisecting the opposite side in s : the centre of gravity will then lie in the intersection of those lines. Or, draw a line from any angle B_2 , bisecting the opposite side, and the centre of

FIG. 74.

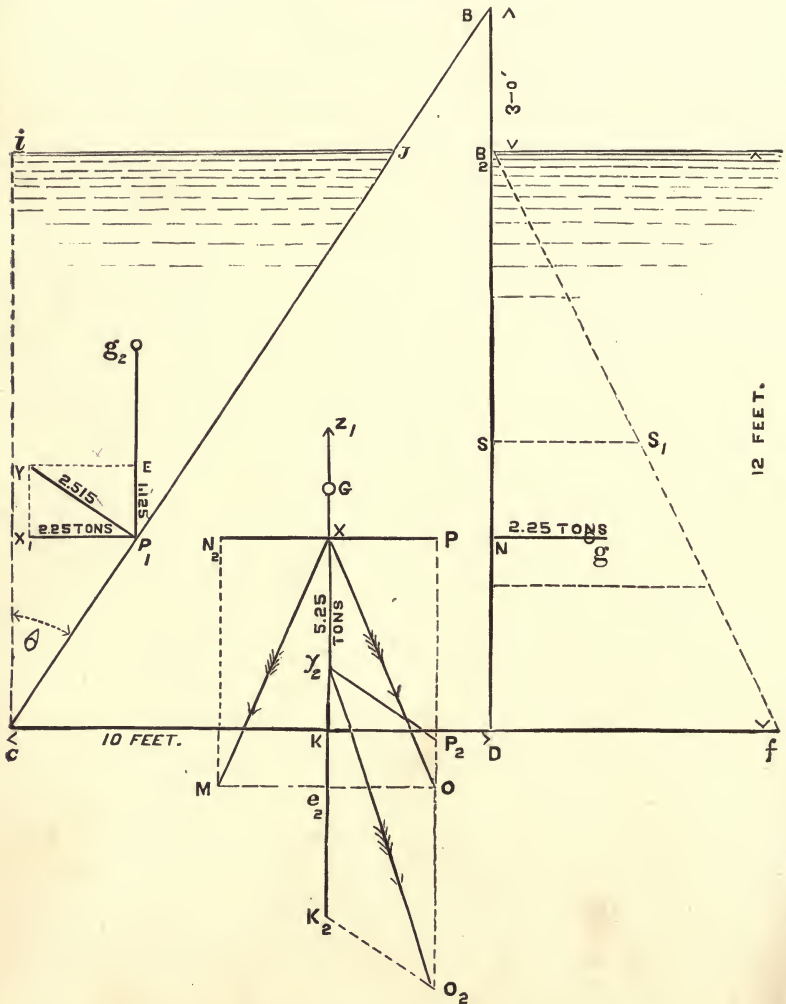

horizontal resultant through g will meet B_2D in N , at two-thirds the depth B_2D .

Let DCB be a section of wall one foot long. Let B_2D

gravity will lie in this line, at one-third the height from the side bisected. The centre of gravity is at two-thirds the vertical depth $B_2D = \frac{2}{3}h$ from B_2 .

$= h = 12$ ft. The centre of gravity of the submerged wall surface B_2D is at one-half its height, $= \frac{h}{2}$. The total pressure of water p upon the wall-surface B_2D equals the product of the surface *area*, $B_2D = A_1$, into the weight of one cubic foot of water, w_1 , into one-half the height, =

$$\begin{aligned}
 p &= A_1 w_1 \frac{h}{2} = w_1 \frac{h^2}{2} & (1) \\
 &= (12 \times 1) \times 62.5 \times \frac{12}{2} \\
 &= 4500 \text{ pounds} = 2.25 \text{ tons.}
 \end{aligned}$$

Draw this total pressure to scale, in the resultant gN , meeting B_2D in N .

The effect of a pressure, when applied to a solid body, is the same at whatever point in the line of its direction it is applied; so we may consider gN as acting upon the wall either at N or at x , in the vertical through the centre of gravity of the wall.

The force tending to push the wall along horizontally is gN .

397. Water Pressure upon an Inclined Surface.

—The maximum resultant of pressure of water upon the inclined plane JC has a direction perpendicular to the plane, and meets the plane in P_1 , at two-thirds the vertical depth of the water.

The entire weight of the triangular body of water CiJ is supported by the masonry surface JC . Its vertical pressure resultant upon JC passes through its centre of gravity in g_2 , and meets JC in P_1 , at two-thirds the vertical depth iC or JC . Its horizontal pressure resultant also meets JC in P_1 .

Let x_1 be the symbol of its horizontal resultant.

“ <i>e</i>	“	“	“	vertical	“
“ <i>y</i>	“	“	“	maximum	“

The horizontal effect of the pressure, x_1 , may be computed as acting upon the plane of its vertical projection or trace, iC , and will equal,

$$\begin{aligned} x_1 &= A_1 w_1 \frac{h}{2} = \frac{h^2}{2} \cdot w_1, & (2) \\ &= 2.25 \text{ tons, when } h = 12 \text{ ft.} \end{aligned}$$

Draw $x_1 = 2.25$ tons to scale in x_1P_1 . Let fall a perpendicular upon JC , meeting it in P_1 ; then will the angle yP_1x_1 equal the angle $JCi = \theta$, and yP_1 will equal *

$$\begin{aligned} y &= x_1 \cdot \sec \theta = \left\{ w_1 \frac{h^2}{2} \right\} \cdot \sec \text{ angle } x_1P_1y & (3) \\ &= 2.515 \text{ tons;} \end{aligned}$$

and eP_1 will equal

$$\begin{aligned} e &= x_1 \cdot \tan \theta = \left\{ w_1 \frac{h^2}{2} \right\} \cdot \tan \text{ angle } x_1P_1y & (4) \\ &= 1.125 \text{ tons.} \end{aligned}$$

The horizontal force tends to displace the wall horizontally. The vertical downward force tends to hold the wall in place, by friction due to its equivalent weight.

If water penetrates under the base of the wall, it will there exert an upward pressure upon the base, opposed to the downward pressure upon JC , and to the weight of the wall, with *maximum* theoretical effect equal to area CD into depth of its centre of gravity into the weight of one cubical foot of water.

Let z_1 be the symbol of the maximum upward pressure, and let c_1 be the ratio of the effective upward pressure in any case to the maximum.

Draw c_1z_1 in the vertical line through the centre of gravity of the masonry, in Gz_1 .

When computing the resultant weight of the masonry,

* *Vide* trigonometrical diagram and table in the Appendix.

opposed to the horizontal water pressure, deduct from the weight of wall the excess of upward, c_1z , over downward pressure, e , $= c_1z_1 - e$.

398. Frictional Stability of Masonry.—The *weight*, W , in pounds, of the wall (of one foot length) equals its sectional area $DCB = A$, in square feet, into the weight of one cubical foot w of its material :

$$W = Aw. \quad (5)$$

The downward *resultant of weight* is

$$W_r = (Aw) + e - (c_1z_1). \quad (6)$$

The upward pressure of the water upon the base will rarely exceed .50 per cent. of the theoretical maximum, even though the wall is founded upon a coarse porous gravel, or upon rip-rap, without a like upward relief of backfilling.

The *frictional stability*, S , of the wall, equals its resultant weight into its coefficient, c , of friction,

$$S = \{ W + e - (c_1z_1) \} \times c. \quad (7)$$

Foundations of masonry upon earth are usually placed in a trench, by which means the frictional stability upon the foundation is aided by the resistance of the earth side of the trench, and the coefficient thus made at least equal to unity. In such case the measure of resistance to horizontal displacement is the friction of some horizontal or inclined joint.

The value of the adhesion of the mortar in bed-joints is usually neglected in computations of horizontal stability, and sufficient frictional stability should in all cases be given by weight, so that the resistance of the mortar may be neglected in the theoretical investigation.

If, however, the mortar is worthless, or its adhesion is

destroyed by frost or careless workmanship, or otherwise, then the mortar becomes equivalent to a layer of sand as a lubricant, and the coefficient of friction may thus be reduced very low.

399. Coefficients of Masonry Friction.—The following table of coefficients of masonry frictions will be found useful.* They are selected from several authorities, and have been generally accepted as mean values.

TABLE NO. 84.

COEFFICIENTS OF MASONRY FRICTIONS (DRY).

		COEF.	ANGLE OF REPOSE.
			° /
Point dressed granite	(medium) on dry clay	.51	27.0
" " "	" " moist clay	.33	18.15
" " "	" " gravel	.58	30
" " "	" " like granite	.70	35
" " "	" " common brickwork	.63	32.2
" " "	" " smooth concrete	.62
Fine cut granite	" " like granite	.58	30
Very fine cut granite	" " " " " "	.61	30.30
" " "	" " pressed Beton Coignet	.61	30.30
Dressed hard limestone	(medium) " like limestone	.38	20.48
" " "	" " brickwork	.60	31
Beton blocks	(pressed) " like Beton blocks	.66	33.15
Polished marble	" " common bricks	.44	23.45
" " "	" " fine cut granite	.61	30.30
Common bricks	" " common bricks	.64	32.38
" " "	" " dressed hard limestone	.60	31

When S and x_1 are equal to each other, the wall is just upon the point of motion, and x_1 must be increased; that is, more weight must be given to the wall to ensure frictional stability.

Let the water be withdrawn from the side BD , Fig. 74, and let the upward pressure attain to one-half the maximum, and the coefficient be that of a horizontal bed-joint upon a concrete foundation, assumed to be .62, then $S =$

* Vide § 353, pp. 344, 345.

$(w + e - .50z_1) \times c = 2.79$ tons, and $x_1 = 2.25$ tons, and the wall has a small margin of frictional stability.

The weight of the wall should be increased until it is able to resist a horizontal thrust of at least $1.5x_1$, or until $S = 1.5x_1$, when the equation of *frictional stability* becomes

$$S = (w + e - c_1z_1) \times c = 1.5x_1, \quad (8)$$

in which

- w is the weight of masonry above any given plane.
- e “ vertical downward water pressure resultant.
- z_1 “ maximum upward water pressure resultant.
- c_1 “ ratio of effective upward water pressure to the maximum.
- c “ coefficient of friction of the given section upon its bed.
- x_1 “ horizontal water pressure resultant.
- S “ symbol of frictional stability.

400. Pressure Leverage of Water.—Since the horizontal resultant of the water-pressure has its point of application above the level of D , in N , its *moment of pressure leverage*, L , has a magnitude equal to DN , or $Kx = \frac{1}{3}h$, into the horizontal resultant.

$$L = A_1w_1 \frac{h}{2} \times \frac{h}{3} = \frac{h^3}{6} w_1. \quad (9)$$

401. Leverage Stability of Masonry.—The moment of pressure-leverage of the water tends to overturn the wall about its toe, D or C , Fig. 74, opposite to the side receiving the pressure alone, or the maximum pressure.

Let the weight of DCB , per cubical foot, be assumed 140 pounds, an approximate weight for a mortared rubble wall of gneiss, or mica-slate; then the total weight above the bed-joint CD , is $140A = 5.25$ tons, which we may con-

sider as acting vertically downward through G , the centre of gravity of DCB .

Plot to scale this vertical resultant of weight in $x e_2 = 5.25$ tons (neglecting for the present the upward and downward pressures of the water), and the horizontal resultant of water pressure in $x N_2 = 2.25$ tons, and complete the parallelogram $x N_2 M e_2$; then the diagonal $x M$, is in magnitude and direction the final resultant of the two forces. The resultant arising from the horizontal pressure on JC , and weight of the masonry, is in magnitude and direction $x O$.

If the directions of $x M$ and $x O$ cut the base DC , then the wall has, theoretically, leverage stability, but if the directions of these diagonals are outside of DC , then the wall lacks leverage stability and will be overturned.

For safety, the direction of $x M$ should cut the base at a distance from K not exceeding one-half KC , and the direction of $x O$ cut the base at a distance from K not exceeding one-half KD .

402. Moment of Weight Leverage of Masonry.—

Since the vertical resultant of weight of masonry takes its direction through G , and cuts DC at a distance from C , the point or fulcrum over or around which the weight must revolve, the *moment of weight leverage* of the wall has a magnitude, when resisting revolution to the right, equal to the distance KD into the vertical weight resultant; and when resisting revolution to the left, equal to the distance KC into the vertical weight resultant.

Let the symbol of distance of K from the fulcrum, on either side, be d , and its value be computed or taken by scale, at will; and let the symbol of moment of weight leverage be M , then

$$M = Awd. \quad (10)$$

For double stability, or a coefficient of safety equal to 2, $\frac{Awd}{2}$ must, at least, be equal to $A_1w_1\frac{h^2}{6}$, or

$$M = \frac{h^3}{3}w_1.$$

403. Thickness of a Vertical Rectangular Wall for Water Pressure.

Let h be the height of the wall and of the water.

“ w “ weight of a cubic foot of the masonry.

“ w_1 “ “ “ “ “ water.

“ z “ required thickness of the wall.

Then $h \times z \times \frac{z}{2} \times w =$ leverage moment of weight of wall, $= \frac{hz^2w}{2}$; and $h \times \frac{h}{2} \times w_1 \times \frac{h}{3} =$ leverage moment of pressure of water = for double effect, $\frac{h^3w_1}{3}$.

The equation for a vertical rectangular wall, Fig. 75, that is to sustain quiet water level with its top, and that just balances a double effect of the water is :

$$\frac{hz^2w}{2} = \frac{h^3w_1}{3},$$

from which we deduce the equation of thickness,

$$z = \left\{ \frac{h^3w_1}{3} \times \frac{2}{hw} \right\}^{\frac{1}{2}} = \left\{ \frac{h^2w_1}{1.5w} \right\}^{\frac{1}{2}}. \quad (11)$$

404. Moments of Rectangular and Trapezoidal Sections.—Let $DCEB$, Fig. 75, be a vertical rectangular wall of masonry, of sectional area exactly equal to the triangular section of wall in Fig. 74, viz., 15 feet in height and 5 feet in breadth, and weighing, also, 140 pounds per cubical foot. Let the depth of water which it is to sustain upon either side, at will, be 12 feet.

The horizontal resultant of water pressure is

$$w \frac{h^2}{2} = 2.25 \text{ tons,}$$

and the vertical resultant of weight of wall into the coefficient (.62) of friction is

$$[W - (.25z_1)] \times c = 2.96 \text{ tons.}$$

This leaves a small margin of frictional stability.

The vertical weight resultant is

$$(Aw) - (.25z_1) = 4.78 \text{ tons,}$$

or, if there is no upward pressure,

$$Aw = 5.25 \text{ tons.}$$

Plot to scale the horizontal and vertical resultants from their intersection in x , and complete the parallelogram $xPMe_2$; then will the diagonal xM be the final resultant of the two forces.

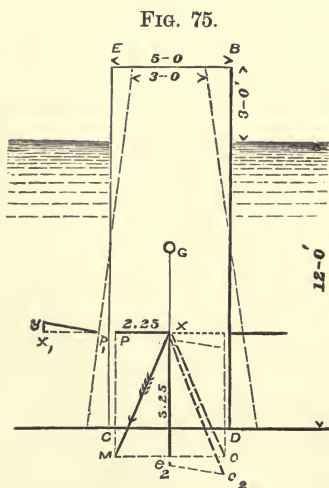

The direction of the diagonal now cuts the base very near the toe C , and the given wall with vertical rectangular section lacks the usual coefficient of leverage stability, though it was found to have ample leverage stability in the equal triangular section.

If we now give to this same wall a slight batter upon each side, as indicated by the dotted lines, its final resultant, arising from the horizontal water pressure, will lie in xO_2 ,

Plot to scale the horizontal pressure resultants in their respective directions through P and P_1 , and the weight resultant in its vertical direction through the centre of gravity,* G , and complete the parallelograms. The diagonals then give the directions and magnitudes of the maximum leverage effects.

The diagonal xO cuts the base CD at a distance from K less than half KD ; the diagonal xM cuts the base at a distance from K more than half the distance KC .

The leverage stability of the wall is therefore satisfactory to resist pressure from the left, but has not the desired factor of safety to resist pressure from the right.

405. Graphical Method of Finding the Leverage Resistance.—The ratio of leverage resistance may be obtained from the sketch by scale, as follows: Extend the base, JO , of the parallelogram upon the right, indefinitely; draw a broken line from x through D , cutting JO in r_1 ; then the ratio of leverage stability against the water pressure upon EC is to unity as Jr_1 is to JO .

Also extend KO_2 indefinitely; draw a broken line from y_2 through the toe C , cutting KO_2 in r_2 ; then the ratio of leverage stability against the *maximum* water pressure upon BD is to unity as Kr_2 is to KO_2 .

The ratio of r_2O_2 to r_2K exceeds .5, but the ratio of rM to rJ is less than .5; therefore the effect of the horizontal pressure xP to overturn the wall exceeds the effect of the maximum pressure yP_1 to overturn the wall.

406. Granular Stability.—We have found the *maxi-*

* The centre of gravity of a rectangular symmetrical plane, Fig. 75, lies in the intersection of its diagonals.

The centre of gravity of a trapezoidal plane $DCEB$, Fig. 76, may be found graphically, thus: Prolong CD to i , and make $Ci = EB$. Also prolong EB to k , and make $Bk = CD$. Join ki . Bisect CD and EB , in d and b , and join db . The centre of gravity G lies in the intersection of the lines db and ik .

mm water pressure resultant upon the inclined side, *JC* (Fig. 74), to be $yP_1 = y = 2.515$ tons; its direction to be perpendicular to *JC*, and its point of application to be at two-thirds the vertical depth *JC*, or *iC*.

Plot this inclined resultant, in the prolongation of the line yP_1 , from a vertical through *G*, in $y_2P_2 = 2.515$ tons; and plot the vertical weight resultant of the wall from the intersection y_2 , in $y_2K_2 = 5.25$ tons; complete the parallelogram $y_2P_2O_2K_2$, then the diagonal y_2O_2 is in magnitude and direction the maximum pressure resultant of the two forces tending to crush the granular structure of the wall and its foundation.

The following table of data relating to computed pressures in masonries of existing structures, is condensed and tabulated from memoranda* given by Stoney and from other sources:

TABLE No. 85.

COMPUTED PRESSURES IN MASONRY.

KIND OF MASONRY.	LOCATION.	MATERIAL.	PRESSURE IN LBS. PER SQ. FOOT.
Piers, All Saints Church.....	Angers.	Forneaux stone.	86,016
Pillar, Chapter House.....	Elgin.	Red sandstone.	40,096
Pillars, dome St. Paul's Church	London.	Portland limestone.	39,424
" " St. Peter's Church	Rome.	Calcareous tufa.	33,376
Aqueduct, pier.....	Marseilles.	Stone.	30,240
Arch bricks, bridge, Charing } Cross.....	London.	London paviers.	26,880
Pier bricks, Suspension Bridge.	Clifton.	Staffordshire blue bricks.	22,400
Bridge pier.....	Saltash.	Granite.	21,280
Arch concrete, bridge, Char- } ing Cross.....	London.	Port. Cement, 1; gravel, 7.	17,920
Arch bricks, viaduct.....	Birmingham.	Red bricks.	15,680
Brick chimney.....	Glasgow.	Brick.	20,160
Bricks, estimated pressure on } leeward side in a gale.... }	33,600

Long span bridges have sometimes pressures at their springing exceeding 125,000 pounds per square foot.

* The Theory of Strains in Girders and Similar Structures. New York, 1873.

Experimental data of the ultimate strength of masonry in large masses has not been obtained in a sufficient number of instances to determine a limit generally applicable for safe practice.

Failure first shows itself by the spalling off of the angles or edges of the stones, or by the breaking across of stones subjected to a transverse strain, and next by the crushing of the mortar.

407. Limiting Pressures.—From experiments of several engineers upon the ultimate crushing strength of small cubes of dressed stones (1 inch and $1\frac{1}{2}$ inch square), and from computations of pressures upon the lower courses of tall stacks and spires, the data of the following table has been prepared :

TABLE No. 86.

APPROXIMATE LIMITING PRESSURES UPON MASONRY.

	Av. weight laid in mortar, per cubic foot.	Approx. ultimate resistance of dry, dressed, one-inch cubes.	Est. safe static pressure per sq. ft. on thick blocks, unladen.	Est. safe pressure per sq. ft. in coursed rubble masonry, at 2 ft. from edge, when laid in strong mortar.
Limestone.	152 lbs.	4,000 lbs.	115,000 lbs.	50,000 lbs.
Sandstone.	132 "	6,000 "	170,000 "	50,000 "
Granite.	154 "	10,000 "	280,000 "	60,000 "
Brick.	120 "	2,500 "	72,000 "	35,000 "

McMaster mentions* that in Spain, and in some instances in France, the limit of pressure in stone masonry has been taken in practice as high as 14 kilogrammes per square centimeter (= 28678 lbs. per square foot); but in the majority of cases the limit is taken at from 6 kilometers to 8.50 kilometers per square centimeter.

* Profiles of High Masonry Dams. New York, 1876.

The ultimate granular resistance of the masonry is largely dependent upon the strength of the mortar, and upon the skill applied to the dressing and laying of the stones.

It is not advisable to allow either a direct or resultant pressure exceeding 140 pounds per square inch within one foot of the face of rubble masonry, or 225 pounds per square inch in the heart of the work; and these limits should be approached only when both materials and workmanship are of a superior class.

The resultant of the horizontal pressure is seen to cut the base-line nearer to the toe, or fulcrum, over which the resultant tends to revolve the wall, than does the resultant of maximum pressure; the crushing strain is therefore greater near the face of the masonry from the horizontal than the maximum resultant.

Care must be exercised, in high structures, that the safe pressure limit near the edge is not exceeded, lest the edge spall off, and the fulcrum be changed to a position nearer the centre of the wall, and the leverage stability thus reduced.

408. Table of Walls for Quiet Water.—The following table gives dimensions for walls to sustain quiet water on either side, and also on the back only, with a limiting face batter of two inches per foot rise :

TABLE No. 87.

APPROXIMATE DIMENSIONS OF WALLS TO RETAIN WATER.

For granite rubble walls, in mortar, of specific gravity 2.25, or weight, 140 pounds per cubic foot; to retain quiet water level with the top of the wall.

Height of water and wall, in feet.	VERTICAL RECTANGULAR WALL. Breadth in feet.	PRESSURE ON EITHER SIDE. SYMMETRICAL PARTITIONS.		PRESSURE ON BACK ONLY.		
		Top breadth in feet.	Bottom breadth in feet.	Top breadth in feet.	Facebatter in inches per ft. rise.	Bottom breadth in feet.
4	3.5	3.5	3.5	3.5	0	3.5
5	3.5	3.5	3.5	3.5	0	3.5
6	3.5	3.5	3.5	3.5	0	3.5
7	4.0	3.5	4.25	3.5	$\frac{1}{2}$	4.0
8	4.5	3.5	5.25	3.5	$1\frac{1}{2}$	5.0
9	5.0	3.5	6.00	3.5	2	5.75
10	5.5	3.5	6.50	3.5	2	6.75
11	6.0	3.5	7.25	3.5	2	7.25
12	6.75	4.0	7.75	4.0	2	7.83
13	7.25	4.0	8.50	4.0	2	8.67
14	7.75	4.0	9.25	4.0	2	9.50
15	8.25	4.0	10.00	4.0	2	10.50
16	9.00	4.0	10.75	4.0	2	11.50
17	9.50	4.0	11.67	4.0	2	12.00
18	10.00	5.0	11.75	5.0	2	12.50
19	10.50	5.0	12.67	5.0	2	13.67
20	11.00	5.0	13.33	5.0	2	14.50
21	11.50	5.0	14.00	5.0	2	15.25
22	12.25	5.0	14.83	5.0	2	16.25
23	12.75	5.0	15.75	5.0	2	17.25
24	13.25	5.0	16.50	5.0	2	18.25

The top thickness is to be increased if the top of the wall is exposed to ice-thrust; and the whole thickness must be increased if water is to flow over the crest, according to the depth of the crest, and its initial velocity of approach.

Unless partition-walls rest on solid rock, or on impervious strata of earth, as they should, percolation under the

wall must be prevented by a concrete or puddle stop-wall, or by sheet-piling; or the previous strata must be effectually sealed over.

409. Economic Profiles.—It is evident, from the above investigations, that the profile has an important influence upon the leverage stability of a wall of given weight of material, and therefore, for a given stability, upon economy of material.

The leverage stability against pressures of water upon the vertical sides of triangular or trapezoidal sections of masonry is greater than the leverage resistances to pressures upon their inclined sides, as is graphically illustrated in the above sketches; hence there is an advantage in giving all the batter to the side opposite to the pressure.

The vertical rectangular sections are least economic, and the triangular sections most economic of material.

When some given thickness is assumed for the top of a retaining wall, to give it stability against frost, or displacement from any cause, then theory makes both sides vertical from the top downward until the limiting ratio of leverage stability is reached, and then gives to the side opposite to the pressure a parabolic concave curve.

It may be necessary to widen the base of high walls upon both sides beyond the breadth required for leverage stability, to distribute the weight sufficiently upon a weak foundation. Practical considerations, in opposition to theory, tend to rectangular vertical sections.

The engineer who is familiar with both theory and practice, adjusts the profile for each given case, so as to attain the requisite frictional, leverage, and granular stabilities, in the most substantial and economical manner, having due regard to the quality and cost of materials, and the skill and cost of the required labor.

410. Theory of Earth Pressures.—Earth filling of the different varieties behind retaining walls, is met in all conditions of cohesiveness between that of a fluid and that of a solid.

The same filling, in place, is subject to constant changes in its degree of cohesion, as its moisture is increased or diminished, or as its pressure and condensation is increased, or as it is subjected to the tremulous action of traffic over it. The theory of earth pressure, therefore, leads to less certain results than does the theory of water pressure.

We have seen (§ 353) that different earths have different natural *angles of repose* when exposed to atmospheric influences, and they also tend to assume their natural *frictional angle* when deposited in a bank. If we make a broad fill with earth, behind a vertical wall and then suddenly remove the wall, a portion of the earth, of triangular section, will at once fall, and the slope will assume its natural frictional angle. If we make such a fill even with the top of a vertical rectangular wall, whose thickness is only equal to one-fourth of its height, then the earth will overturn the wall. This is evidence that a portion of the earth produces a lateral pressure. If the earth is fully saturated with water, its lateral pressure may be nearly like that of a fluid of equal specific gravity. If the earth is compact like a solid, its thrust may be nearly like that of a rigid wedge.

Let $LDBJ$, Fig. 77, be an earth-fill behind a vertical retaining wall DB . Let LDV_1 be the natural frictional angle $= \phi$, of that earth filling. It is evident that the portion of earth LDV_1 will produce no thrust upon the masonry, because it would remain at rest if the wall was removed. Suppose all the filling above DV_1 to be divided into an infinite number of laminæ whose planes of cleavage all meet at one edge in D , and radiate from D . Then the

by the plane DJ , which bisects the angle BDV_1 . Let the wedge BDJ , then be increased in dimensions by revolving the side JD to the right, around D ; then its weight, as a solid, will rest more upon V_1D , and its lateral thrust will not be increased. Let the wedge BDJ , then be reduced in dimensions by revolving the side JD to the left; then its total weight and its ability to produce lateral thrust upon the masonry will be reduced. We may therefore assume that that portion of the mass V_1DBJ , included in the upper wedge formed by bisecting the angle V_1DB will be the maximum portion of the earth that will first fall if the wall is suddenly removed, and that the thrust of the wedge BDJ , if considered alone, and as devoid of friction upon the plane JD , will give a safe theoretical maximum effect upon the masonry of the whole mass V_1DBJ .

The practical value of such assumption has been ably demonstrated by Coloumb, Prony, Canon Moseley, Rankine, Neville, and others.

411. Equation of Weight of Earth-Wedge.—The weight W_2 of the wedge of earth (considered as one foot in length), in pounds, equals its surface area DBJ , in square feet, $= A_2$, into the weight of one cubical foot of the material $= w_2$.

$$W_2 = A_2 w_2. \quad (12)$$

Let the symbol of the frictional angle LDV of the earth filling be ϕ ; then will the angle

$$BDJ = \frac{90^\circ - \phi}{2} = \left\{ \frac{\frac{1}{2}\pi - \phi}{2} \right\} = \theta = \text{angle } V_1DJ.$$

Let the height BD equal 12 feet, $= h$; then the area of DBJ will equal DB into one-half $BJ =$

$$A_2 = h \times \frac{h}{2} \tan \theta = \frac{h^2}{2} \cotan (\phi + \theta). \quad (13)$$

412. Equation of Pressure of Earth-Wedge.—

Assume the weight of the wedge $DBJ = A_2 w_2 = W_2$ to be gathered into its vertical resultant passing through its centre of gravity, g ; then the thrust P of the wedge equals its weight into its horizontal breadth BJ , divided by its vertical height $BD =$

$$P = A_2 w_2 \tan \theta = W_2 \cotan (\phi + \theta). \quad (14)$$

Draw the vertical resultant W_2 to scale in eP , meeting the inclined plane JD , in P .

The thrust effect of W_2 will have its maximum action in a line parallel to the line DV_1 , since the mass V_1DBJ , as a whole, tends to move down the plane V_1D .

The theoretical reaction from the wall, necessary to sustain W_2 , will then be in a direction parallel to DV_1 , cutting the vertical resultant in P . Draw the reaction of the wall to scale in nP . The reaction of the plane JD is in direction and magnitude equal to the diagonal Py , of the parallelogram of which W_2 and P form two sides. Draw the reaction of JD to scale in VP . Then will the three resultants eP , nP , and VP be in equilibrium about the point P .

Let $\phi = 30^\circ$.

Assume the filling to be of gravel, weighing 125 pounds per cubic foot, and that after a storm, its drains being obstructed, its voids are filled with water, increasing the weight to 140 pounds per cubic foot, $= w_2$; then

$$\begin{aligned} W_2 &= \frac{h^2}{2} \cotan (\phi + \theta) w_2 \\ &= 12 \text{ feet} \times \frac{12}{2} \text{ feet} \times .57735 \times 140 \text{ pounds} \\ &= 5,820 \text{ pounds} = 2.91 \text{ tons.} \end{aligned}$$

The reaction from the wall necessary to sustain the weight of the wedge $JBD =$

$$\begin{aligned}
 P &= W_2 \tan \theta = \frac{h^2}{2} \cotan^2 (\phi + \theta) w_2 & (15) \\
 &= 2.91 \text{ tons} \times .57735 \\
 &= 1.68 \text{ tons.}
 \end{aligned}$$

The horizontal effect of $P =$

$$\begin{aligned}
 x &= P \cos \phi = A_2 w_2 \tan \theta \cos \phi & (16) \\
 &= 1.68 \text{ tons} \times .86602 = 1.45 \text{ tons.}
 \end{aligned}$$

The thrust of the wedge tending to push away and to overturn the wall is equal to the reaction from the wall necessary to sustain the wedge in position. We find its *horizontal* effect in this case to be 1.45 tons, and this is the maximum effect, $= x$, tending to displace the wall horizontally.

413. Equation of Moment of Pressure Leverage.

—The maximum *moment of pressure leverage*, L , tending to overturn the wall around its toe, equals x into the height, in feet, above D at which x meets the wall.

When the wall is vertical and the surface of filling horizontal, x always meets BD at one-third h from D , $= \frac{h}{3}$; therefore the equation of moment of pressure leverage becomes

$$\begin{aligned}
 L_1 &= x \frac{h}{3} = (A_2 w_2 \tan \theta \cos \phi) \frac{h}{3} & (17) \\
 &= 1.45 \text{ tons} \times \frac{12 \text{ ft.}}{3} = 5.80 \text{ tons.}
 \end{aligned}$$

414. Thickness of a Vertical Rectangular Wall for Earth Pressure.—The moment of weight leverage of

a vertical rectangular wall is $\frac{hz^2w}{2}$, in which z is the thickness of the wall.

The double moment of pressure leverage of earth level with the top of the wall is

$$(h^2 w_2 \tan^2 \theta \cos \phi) \times \frac{h}{3} = \frac{h^3}{3} w_2 \tan^2 \theta \cos \phi.$$

When the wall just balances the theoretical double pressure of the earth level with its top,

$$\frac{hz^2 w}{2} = \frac{h^3}{3} w_2 \tan^2 \theta \cos \phi,$$

from which is deduced the equation of thickness for a vertical rectangular wall,

$$z = \left\{ \frac{2h^3 w_2 \tan^2 \theta \cos \phi}{3hw} \right\}^{\frac{1}{2}} = \left\{ \frac{h^2 w_2 \tan^2 \theta \cos \phi}{1.5w} \right\}^{\frac{1}{2}} \quad (18)$$

415. Surcharged Earth-Wedge.—When the earth-fill behind a wall is carried up above the top level BJ of the wall, and is sloped down against the top angle B , or upon the top of the wall, the fill DBF is then termed a *surcharged* fill.

Its weight W_2 is, as in the case of the level fill, per lineal foot,

$$W_2 = A_2 w_2. \quad (19)$$

To compute the pressure of the surcharged fill, we may divide the mass $V_1 DBF$ into two wedges by a plane DF , bisecting the angle $V_1 DB$, and take the action of the wedge FDB as equivalent to the effective action of the whole mass $VDBF$.

Let the natural frictional angle of the earth-fill be

$$\phi = 30^\circ.$$

The area A_2 of the wedge FDB may be computed by any method of ascertaining the area of a triangular super-

fices. If, with a given slope BF , the fill does not rise as high as F , and its surface level cuts $F'B$ and $F'J$ between the levels of F and B , then its area is ascertained by any method of ascertaining the superficies of a trapezium.

Let fall upon DF a perpendicular from B , meeting DF in i ; then the distances Di and iF are equal, each, to the cosine of the angle $BDF = \cos. \frac{90^\circ - \phi}{2} = \cos \theta$; and the distance iB is equal to $\sin \frac{90^\circ - \phi}{2} = \sin \theta$.

Let the height $DB = h = 12$ feet.

The area BDF equals the length DF into one-half $iB =$

$$\begin{aligned} A_2 &= h \times 2 \cos \theta \times h \frac{1}{2} \sin \theta = h \cos \theta \times h \sin \theta \quad (20) \\ &= (12 \times .866) \times (12 \times .5) = 62.53 \text{ sq. ft.} \end{aligned}$$

Let the mean weight of the fill, which is quite sure to be drained above the level BJ , be assumed 130 pounds per cubical foot.

416. Pressure of a Surcharged Earth-Wedge.—

Suppose the weight to be gathered into its vertical resultant passing through the centre of gravity g_2 , of the mass DFB . This vertical resultant will meet the plane FD in P_1 at a level higher than P .

The wedge-thrust P_1 , due to the weight W_2 , equals the weight into the horizontal breadth BJ , divided by the height $DB =$

$$P_1 = W_2 \tan \theta = A_2 w_2 \cotan (\phi + \theta) = \quad (21)$$

$$62.53 \text{ sq. ft.} \times 130 \text{ lbs.} \times .577 = 4690.38 \text{ lbs.} = 2.345 \text{ tons.}$$

The maximum pressure-action of the weight upon the wall is in a direction parallel to V_1D , the natural frictional angle ϕ , of the filling material. Its *horizontal pressure effect*, x_1 , is therefore :

$$x_1 = P_1 \times \cos \phi = A_2 w_2 \tan \theta \cos \phi = \quad (22)$$

$$2.345 \text{ tons} \times .866 = 2.03 \text{ tons.}$$

The maximum horizontal pressure resultant takes its direction through P_1 and meets the wall at the altitude of P_1 , which is greater than $\frac{h}{3}$.

We may here observe that, even though the fill DBF is of lighter material than the fill DBJ , so that the total weight of one is exactly equal to the total weight of the other, the pressure leverage effect from the surcharged fill will exceed the pressure leverage effect from the level fill, because its centre of gravity g_2 will be higher than g , its vertical resultant W_2 will meet the plane JD in P_1 at a point higher than P , and its horizontal resultant x_1 will meet the wall at a greater altitude from D than will the resultant x .

Let r_h be the symbol of the ratio of h at which x_1 meets the wall from D ; then if x_1 meets DB at $\frac{1}{3}h$, $r_h = .3333$; and if x_1 meet DB at $\frac{1}{2}h$, $r_h = .5$, etc.

417. Moment of a Surcharge Pressure Leverage.

—The maximum *moment of pressure leverage* L_1 , of a surcharged fill, tending to overturn the wall around its toe, equals x_1 into the height, in feet = $(r_h h)$ above D , at which x_1 meets the wall.

$$L_1 = x_1 \times (r_h h) = A_2 w_2 \tan \theta \cos \phi (r_h h) = \quad (23)$$

$$2.03 \text{ tons} \times 5.98 = 12.14 \text{ tons.}$$

418. Pressure of an Infinite Surcharge.—Let BF , Fig. 78, be the natural slope of the filling material, and parallel with DI , which makes with DL the natural frictional angle $LDI = \phi$. Let BF extend indefinitely.

If $IDBF$ is a perfect solid it will be just upon the point of motion down the slope ID ; on the other hand, if $IDBF$

is liquid, of specific gravity equal to the specific gravity of the filling material, it will then exert its maximum pressure upon the wall-face DB .

Let the filling be considered liquid, resting upon the *equivalent* horizontal base DI , and having the *equivalent* horizontal surface BF .

Let fall upon DI a perpendicular from B , meeting DI in j ; then will Bj be an equivalent vertical projection, or trace, of BD . The angle DBj equals the angle $LDI = \phi$. The distance $Bj = h_1$ equals the distance $BD (=h)$ into the cosine of the angle $DBj = h \cos \phi$.

The direct liquid pressure P_1 upon Bj equals $\frac{h_1^2}{2} w_2 =$

$$P_1 = w_2 \frac{h^2}{2} \cos^2 \phi, \quad (24)$$

and the pressure upon BD in the same direction is

$$= w_2 \frac{h^2}{2} \cos^2 \phi,$$

and its maximum resultant has a direction parallel with ID , and meets Bj at one-third the height jB , in m , and BD at one-third the height DB , in P_1 .

The horizontal pressure effect x_1 upon the wall BD , is

$$x_1 = P_1 \cos \phi = w_2 \frac{h^2}{2} \cos^3 \phi = \quad (25)$$

$$130 \text{ lbs.} \times \frac{12^2}{2} \times .6495 = 6079.32 \text{ lbs.} = 3.036 \text{ tons.}$$

The maximum moment of liquid pressure leverage L_1 of the infinite surcharged fill tending to overturn the wall around its toe, equals x_1 into one-third the height BD .

$$L_1 = x_1 \frac{h}{3} = \left(w_2 \frac{h^2}{2} \cos^3 \phi \right) \times \frac{h}{3} = \quad (26)$$

$$3.036 \text{ tons} \times \frac{12 \text{ ft.}}{3} = 12.14 \text{ tons.}$$

419. Resistance of Masonry Revetments.—The elements of stability of a revetment that enables it to sustain the thrust of an earth-filling behind it, are identical with those we have already examined (§ 401), that enable it to sustain a pressure of water.

There must be sufficient weight, W , to give it frictional stability, S , and the profile must be adjusted so that with the given weight the mass shall have the requisite moment M of weight leverage, with an ample coefficient of safety, to resist the thrust of the earth-filling, at its maximum.

The *weight* of wall above any given horizontal plane between B and D (Fig. 77) equals the area of the section above that plane in square feet, into the weight of a cubical foot of the materials of the wall (§ 398),

$$= W = Aw.$$

The *frictional stability*, S , of the wall at the given horizontal plane, that has to resist the horizontal pressure of the earth filling, equals the weight of masonry above that plane, plus the vertical downward pressure of any water that may rest upon its front batter (EC , Fig. 80), less the vertical resultant of upward pressure beneath the plane or in the bed-joints, and into the coefficient of friction of the given section upon its bed (§ 398),

$$S = (W + e - c_1z_1) \cdot c.$$

The moment of weight leverage of the wall that has to resist the overturning tendency of the earth-thrust, equals the weight of the masonry above the given plane into the horizontal distance of the centre of gravity of the masonry from the toe, or fulcrum, over which the thrust tends to revolve it (§ 402),

$$M = Awd.$$

In these equations :

W is the weight above the given plane.

S “ “ frictional stability of the given section.

M “ “ moment of weight leverage of the given section.

e “ “ vertical downward water pressure resultant.

z_1 “ “ vertical upward water pressure resultant.

c_1 “ “ ratio of effective vertical upward water pressure.

c “ “ coefficient of friction of the given section upon its bed.

The moment of weight leverage of the wall must, for a safe coefficient of stability, be equal to double the moment of pressure leverage of the earth fill ; that is, for a level fill we must at least make

$$\frac{Awd}{2} = A_2w_2 \tan. \theta \cos. \phi \frac{h}{3},$$

and for a surcharged fill,

$$\frac{Awd}{2} = A_2w_2 \tan. \theta \cos. \phi (r_h h),$$

and a like margin of frictional stability should be secured.

420. Final Resultants in Revetments.—The height of the wall (Fig. 79) is the same, by scale, as the wall in Fig. 77, whose reactions to sustain the level and surcharged fills we have investigated.

The back of the wall (Fig. 79) is vertical, and the horizontal earth-thrusts against it are as before computed—viz., 1.45 tons for the level fill, and 2.03 tons for the surcharged fill. Draw these horizontal earth-thrust resultants to the left from a vertical line passing through the centre of gravity of the masonry, in their respective directions and at their respective altitudes. Draw in the vertical line the vertical weight resultant of the masonry in PK ; complete the parallelogram PKO_2x ; then will the diagonal PO_2 represent, in

TABLE No. 88.

APPROXIMATE DIMENSIONS OF WALLS TO SUSTAIN EARTH.

For granite rubble walls, in mortar, of specific gravity 2.25, or weight 140 pounds per cubic foot, to retain earth level with the top of the wall.

Height of wall, in feet.	Top breadth of wall, in feet.	Face batter of wall, in inches per foot rise.	Base breadth of wall at lower earth surface, in feet.	Thickness of a vertical rectangular wall, in feet.
4	3.0	0	3.0	3.0
5	3.0	0	3.0	3.0
6	3.0	0	3.0	3.0
7	3.0	0	3.25	3.50
8	3.0	$\frac{1}{2}$	3.83	4.00
9	3.33	$1\frac{1}{2}$	4.83	4.25
10	3.33	$1\frac{1}{2}$	5.00	4.50
11	3.5	$1\frac{1}{2}$	5.25	5.00
12	3.5	2	5.67	5.50
13	3.5	2	6.33	5.83
14	3.5	2	7.00	6.25
15	3.5	2	7.50	6.75
16	4.0	2	8.00	7.25
17	4.0	2	8.67	7.75
18	5.0	2	9.00	8.25
19	5.0	2	9.50	8.75
20	5.0	2	9.87	9.00
21	5.0	2	10.50	9.50
22	5.0	2	11.00	10.25
23	5.0	2	11.33	10.50
24	5.0	2	11.78	10.75

It will rarely be advisable to reduce the top thicknesses given in the table, with a view only to economizing material lest the top courses be too light to withstand the variety of shocks to which they will be liable, and which are not recognized in the common formulas.

Several eminent professors who have written upon the theory of retaining walls, give formulas for determining their proportions; but such formulas usually give too small top breadths, for practical adoption, for low walls, and objectionably great top breadths for high walls.

Each class of wall has its own most convenient top breadth, which remains nearly constant through a large range of height.

Common uncoursed rubble walls of granite, laid dry, should be increased from the above dimensions six inches in the top breadth and thirty-three per cent. in the bottom breadth. If the level earth-filling behind the wall is to be loaded, or subject to traffic, the weight and leverage resistance of the wall are to be increased accordingly.

The thrust of the filling material behind a retaining wall, upon the wall, will be lessened if the filling next the wall is spread in thin horizontal layers and well settled, instead of being allowed to slope against it, as it falls at the head of a dump.

422. Curved Face—Batter Equation.—When it is desired to give to the face a curve, the back being perpendicular, and the top breadth constant, the following equation will assist in determining ordinates at any given depths for plotting a trial section.

Let b be the assumed top breadth, and t the thickness at any given depth d , then

$$t = b + \overset{.075}{.75} \sqrt{d^3}. \quad (27)$$

For illustration, assume the top breadth *not less* than 3.5 feet; then for several given depths, from 0.0 to 30 feet, we have ordinates, or thicknesses, as given in Table No. 89.

Upon the curve thus obtained, steps may be laid off with either vertical or battered risers.

Tests with the equation for moment of leverage stability, will determine whether the risers may cut the curve, or if the inner angle of tread and riser shall lie in the curve.

A slight increase or reduction of the top breadth, or of the fractional multiplier, will increase or reduce the wall-section, as desired.

TABLE No. 89.

THICKNESS AT GIVEN DEPTHS OF A CURVED FACE WALL.

DEPTHS.				THICKNESS.	
<i>Feet.</i>	(<i>b.</i>)	$\frac{.075}{.75} \sqrt{d^2}$		<i>Feet.</i>	
0	3.5	+	.0	=	3.50
4	3.5	+	.6	=	4.10
6	3.5	+	1.10	=	4.60
8	3.5	+	1.69	=	5.19
10	3.5	+	2.37	=	5.87
12	3.5	+	3.12	=	6.62
15	3.5	+	4.36	=	7.86
20	3.5	+	6.71	=	10.21
25	3.5	+	9.38	=	12.88
30	3.5	+	12.32	=	15.82

423. Back Batters, and their Equations.—When for practical or other reasons there is objection to giving all the batter to the front of the wall, and a portion of it is placed upon the back, then it is usually arranged in a series of offsets or steps BD_1 , Fig. 80.

In such case, the weight of the triangle of earth B_2D_1B may be assumed to be supported entirely by the wall, and as producing no lateral thrust upon the wall. This triangle increases the weight leverage of the wall, and moves its weight resultant farther back from the toe C .

Find the centre of gravity of the masonry, in g , and find the centre of gravity of the triangle of earth, in g_2 ; then will the centre of gravity of the two united bodies be in G .

Let LD_1I be the natural frictional angle of the material. Bisect the angle ID_1B_2 by the plane D_1F ; then we may assume the trapezium $D_1B_2F_1F$ to be that portion of the earth-filling that, considered alone, will produce the maximum thrust effect upon the wall, and its horizontal and leverage effects may be computed by equations 21 and 23.

FIG. 80.

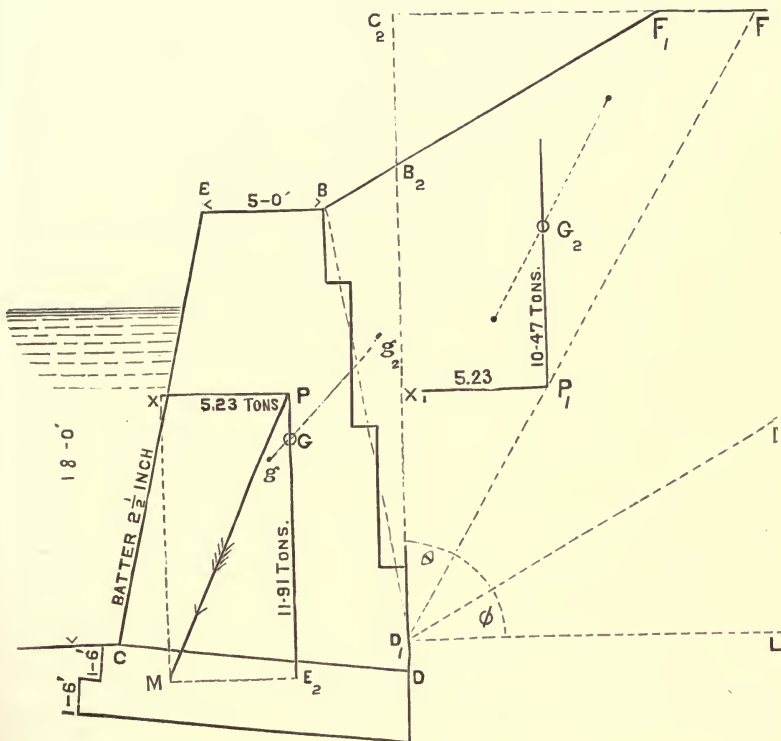

Prof. Moseley's equation* for the maximum pressure of a surcharge similar to this is

$$P_1 = \frac{1}{2} w_2 \left\{ \sec \phi - (h_1^2 \tan^2 \phi + c_2^2)^{\frac{1}{2}} \right\}^2, \quad (28)$$

in which c_2 is the height B_2c_2 .

P_1 " maximum pressure of the earth.

w_2 " weight of one cubic foot of earth.

h_1 " vertical distance D_1c_2 .

ϕ " frictional angle of the earth.

424. Inclination of Foundation.—The frictional stability of a wall upon its foundation is materially in-

* Mechanics of Engineering, p. 426. Van Nostrand, New York, 1860.

Correction; see Preface to Second Edition

creased, and its pressure is more evenly distributed upon the foundation stratum, if an inclination is given to the bed nearly at right angles to the final thrust resultant, as in Fig. 80. Bed-joints may often be similarly inclined with advantage.

A sliding motion in such case involves the additional work of lifting the whole weight up the inclined plane.

425. Front Batters and Steps.—Masons experience a very considerable difficulty in laying the face of rubble walls with batters exceeding two inches to the foot, and often with batters exceeding one and one-half inches to the foot, unless with stones from a quarry where the transverse cleavage varies several degrees from a perpendicular to the rift.

The difficulty is increased when the bed-joints of the work are level from front to rear, as the workmen prefer to make them.

It is especially troublesome to the workmen, and expensive as well, to make face-batters of high walls conform to the theoretical curved batters deduced from the logarithmic equations.

It is better, therefore, to transpose the curve into a series of steps when its tangent inclination exceeds two inches to the foot, in which case the steps may have equal heights and varying projections, as in Fig. 81, which is a revetment upon a navigable river, or may have both varying rise and projection, with batter upon the rise, as in the weir, Fig. 72.

426. Top Breadths.—The thickness at the top of a revetment should in all cases be sufficient, so that its weight will be able to resist the frost expansion thrust of the surface layers of the earth. Sometimes a batter is given to the back of the wall, three or four feet down from the top, to enable the earth to expand readily in a vertical direction,

and thus act with less force horizontally against the backs of the cap-stones.

An increased thickness at the top of the wall, and at all points of depth, is also necessary when the filling is liable to be loaded with construction materials, fuel, merchandise,

FIG. 81.

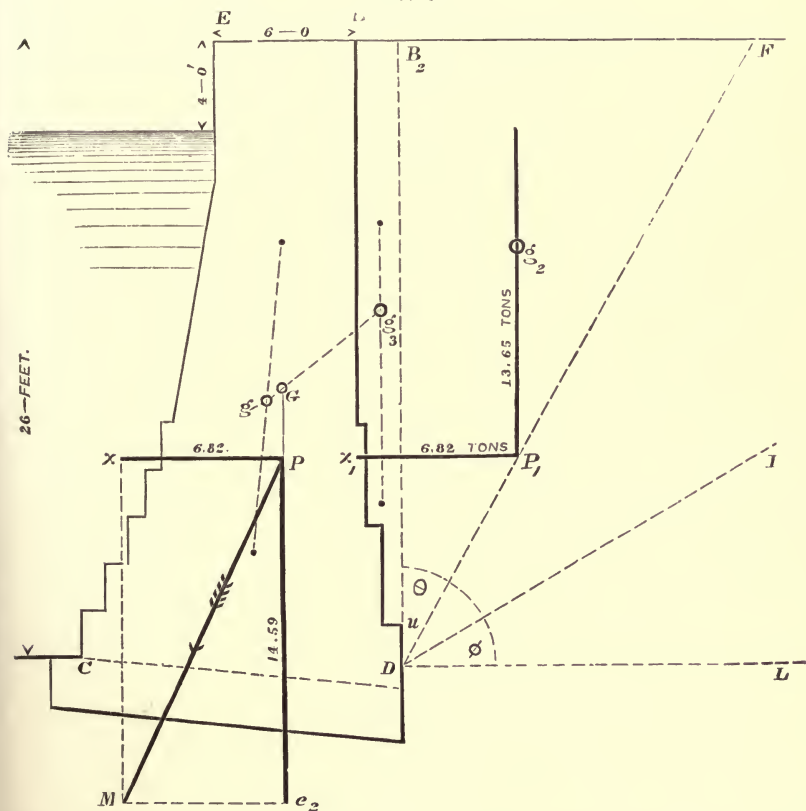

or other weights, or if it is to sustain traffic of any kind. The additional weight may in such case be considered equivalent to a surcharge weight, and the centre of gravity of the filling and of the additional weight will be resolved into their united centre of gravity and the vertical resultant

be considered as passing through this new centre of gravity. The new horizontal thrust resultant will then act upon the wall at a greater altitude, and with greater leverage than the horizontal resultant of filling alone (§ 416), as has been already demonstrated.

In the cases of discharge weirs the floods are considered as surcharge weights, and not only the depth of water behind the weir and upon its crest is to be considered, but

FIG. 82.

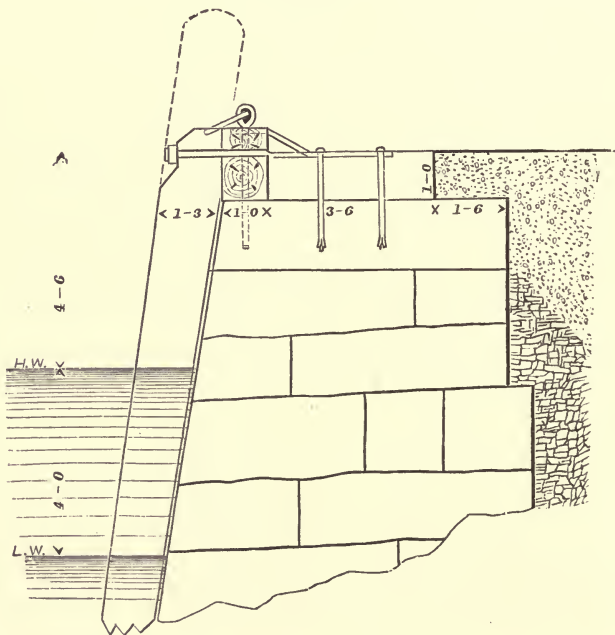

the additional height to which the velocity of approach of the water is due.

If there is but one or two feet depth of water flowing over, then the cap-stones may be subject to the blows of logs, cakes of ice, and such debris as the floods gather.

427. Wharf Walls.—When a wall is to be generally

used for wharf purposes, its face should be protected by fender piles, both for its own advantage and that of the vessels that lie alongside.

Fig. 82 illustrates the method of piling and capping, adopted by the writer, in an extensive *wharf-pier* of one-half mile frontage in one of the deep harbors upon the New England coast. The caps are, in this case, dressed dimension stones, three and one-half feet wide and one foot thick. The wharf log is made up of 12" \times 10" and 12" \times 8" hard pitch pine, placed one upon the other so as to break joints, and tre-nailed together. The anchors of the pile-heads pass through the cap-log, and their bolts pass through the cap-stones into headers specially placed to receive them. The piles are placed eight feet between centres, and each fourth pile extends above the log for a belay pile. Waling pieces of 6" \times 12" hard pine are fitted between the pile-heads, and spiked to the face of the cap-log to confine the pile-heads rigidly in place. Midway between the belay piles are belay rings, whose bolts pass through the cap-logs into headers, and are also anchored by straps to cap-stones.

428. Counter-fortcd Walls.—There is so rarely an economic advantage in counter-fortcd a wall, except in those cases of brick walls where the counter-fort may take the form of a buttress upon the exterior face, that we shall not here devote space to their special theoretical investigation, which, by graphical analysis, is a simple reapplication of the principles already laid down.

429. Elements of Failure.—In our theoretical investigation of the resistances of masonry to sliding or overturning we have supposed the walls to be laid in mortar and solid, and well bonded, so that the mass was practically one solid piece, considered as one foot long.

If any given foot of length, considered alone as a unit

of length, is found stable, and each other foot is equal to it, then evidently the whole length will be stable.

The joints from front to rear in cut and first-class rubble walls are usually laid level, and the workmen intend to give a good bond of one course upon another. When considering the leverage stability of a high wall, at the respective joints, working from top downward, we usually treat the joints as horizontal planes. Let us turn again to the sketch of the partition wall, Fig. 76, which has joints laid off upon it showing an average class of rubble work. Suppose the water to be drawn off from the side EC , and the full water upon the opposite side to be freezing, and the ice exerting a thrust upon the upper courses of the wall. We investigate the leverage stability at the joint jj_1 , and find that it will resist a considerable leverage strain, which for further illustration we assume to be ample. Examining critically the building of the wall, we find that jj_1 is not the real joint, and j_1 the fulcrum to be considered in connection with pressure upon Bj , but in consequence of faulty workmanship, j_2j_3 is the zigzag joint and j_3 the fulcrum, and that the joint, instead of being horizontal, is an equivalent inclined plane on which the wall is quite likely to yield by slipping slightly with each extra lateral strain put upon it.

If in a high and long wall such weaknesses are repeated several times, the result will be a bulge upon the face of the wall, ordinarily reaching its maximum at about one-third the height of the wall, the portion above that level appearing to have been moved bodily forward, and retaining nearly its true batter.

When walls are so high as to require a thickness in a considerable portion of their height exceeding seven or eight feet, careless wall-layers, who are not entitled to the honorable name *mechanic*, often pile up an outside and

inside course, and fill in the middle with their refuse stone, thus producing a miserable structure, especially if it is dry rubble, that is almost destitute of leverage stability, unless a great surplus of stone is put into the wall sufficient to resist the thrust of an earth-backing by compounded weight alone.

Short walls supported at each end may by such transverse motion be brought into an arched form, concave to the pressure, but at the same time into a state of longitudinal tension that will assist in preventing further motion.

If there is the least transverse motion in a mortared wall sustaining water, the masonry ceases from that instant to be water-tight, and if the stones are in the least disturbed on their bed after their mortar has begun to set, the wall will never be tight.

430. End Supports.—Well constructed short walls, supported at each end, such as gate-chamber and wheel-pit walls, have an appreciable amount of that transverse resistance prominently recognized in a beam, which permits their sections to be reduced, an amount dependent on the effective value of such transverse support. The supported ends of long walls transmit the influence of the support in a decreasing ratio, out to some distance from the supports, and walls whose ends abut upon inclines, as in the case of stone weirs across valleys, may be reduced in thickness, ordinarily, at the top and through their whole height, as the height reduces.

431. Faced, and Concrete Revetments.—Walls on deep water-fronts, as in Fig. 81, for instance, when laid within coffer-dams, are often faced with coursed ashler having dressed beds and builds, and backed up with either rubble-work laid in mortar, or with concrete, the headers of the ashler being intended to give the requisite bond between

the two classes of work. Much care must be exercised in such composite work, lest the unequal settlement of the different classes of work entirely destroy the effective bond between them and thus lead to failure.

Such walls have been constructed with perfect success without coffer-dams, of heavy blocks of moulded *beton*, and also successfully by depositing concrete in place in the wall, under water, with the assistance of a caisson mould, or sheet-pile mould, thus forming a monolithic revetment.

Foundations under water to receive masonry structures have also been successfully placed by the last-mentioned system.

Concrete structures under water laid without coffers, however, demand the exercise of a great deal of good judgment, educated both in theory and by practice, and admit only of the most faithful workmanship.

LIBRARY
UNIVERSITY OF
CALIFORNIA

FIG. 83.

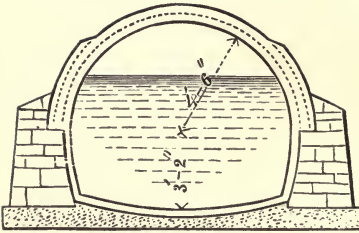

FIG. 84.

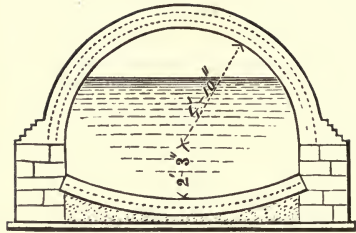

FIG. 85.



FIG. 86.

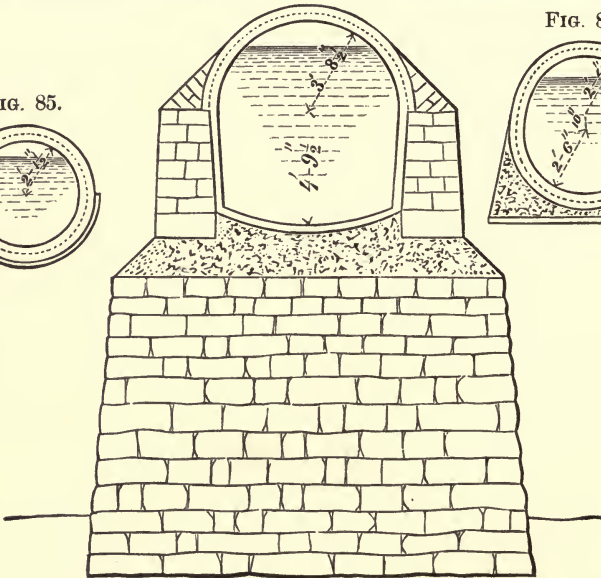
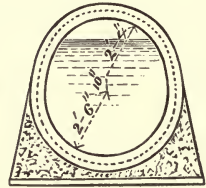

FIG. 87.

FIG. 88.

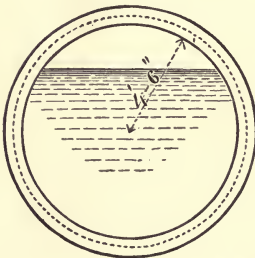
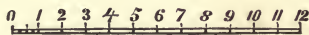
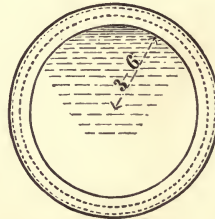

FIG. 89.



CONDUIT SECTIONS.

CHAPTER XX.

MASONRY CONDUITS.

432. Protection of Channels for Domestic Water Supplies.—The observations, sound reasonings, and good judgments that influence municipalities to seek and secure the most wholesome and coolest waters for their domestic uses, compel them also to guard the purity and maintain the equable temperature of the waters as they flow to the point of distribution.

The larger cities, with few exceptions, must lead their waters in artificial conduits, from sources in distant hills, where neither the soils nor atmosphere are tainted by decompositions such as are always in progress in the midst of large concourses of human beings and animals.

Such long water-courses ought to be paved or revetted, or their currents will be impregnated with the minerals over which they flow, and will cut away their banks where the channels wind out and in among the hills. An arch of masonry spanning from wall to wall is then the most sure protection from inflowing drainage, the approach of cattle and vermin, the heating action of the summer sun, and the growth of aquatic plants in too luxuriant abundance.

433. Examples of Conduits.—When proper grades are attainable to permit the waters to flow with free surfaces, such conduits, requiring more than six or eight square feet sectional area are usually, and most economically, constructed of hydraulic masonry.

Figures 83 to 89 illustrate some of the forms adopted in American masonry conduits.

Fig. 87 is a section of the Croton conduit, at a point where it is raised upon embankment. This conduit is 7'-5" wide and 8'-5½" high, and conveys from Croton River to the distributing reservoir in Central Park, New York city, about one hundred million gallons of water daily. The combined length of conduit and of siphons between Croton Dam and Central Park is about thirty-eight miles, and they were completed in 1842.

Fig. 88 is a section of the Washington conduit, which is circular, of 9 feet internal diameter. This leads water from a point in the Potomac River about sixteen miles from the capital, to a distributing reservoir in Georgetown, from whence the water is led to the Government buildings and grounds, and throughout the City of Washington, in iron pipes. This conduit was constructed in 1859.

Fig. 84 is a section of the Brooklyn, L. I., conduit leading the waters of Jamaica and other ponds to the basin adjoining the well of the Ridgewood pumping-engines. This conduit increases in dimensions at points where its volume of flow is augmented from 8'-2" wide to 10'-0" wide, and to a maximum height of 8'-8". It was constructed in 1859.

Fig. 86 is a section of the Charlestown, Mass., conduit, leading the water of Mystic Lake to the well of the Mystic pumping-station. This conduit is 5'-0" wide and 5'-8" high, and was constructed in 1864.

Fig. 85 is a section of the Lowell, Mass., conduit, of 4'-3" diameter. This leads water from a subterranean infiltration gallery along the margin of the Merrimack River, a short distance above Lowell, a portion of the distance to the pumping-station. It was constructed in 1872.

Fig. 89 is a section of the second Chicago tunnel, extend-

ing under Lake Michigan two miles from the shore to the lake crib, and underneath the city to the side opposite to the shore of the lake. It is 7'-0" wide and 7'-2" high in the clear. The masonry of this tunnel consists of three rings of brickwork, the two inner of which have the sides of their bricks in radial lines, and the outer having its sides of brick at right angles to radial lines. This tunnel was completed in 1874.

Fig. 83 is a section of the Boston conduit, commenced in 1875, to lead an additional supply from Sudbury River to the Chestnut Hill reservoir. Its length is sixteen and one-half miles, its width 9'-0", and height 7'-8".

The new Baltimore conduit, as in progress in 1876, is to be 36,495 feet in length, entirely in tunnel, extending from Gunpowder River to the receiving reservoir. The portions lined with masonry are circular in section, of 12 feet clear diameter. The inclination is 1 in 5000, and the anticipated capacity about 170,000,000 gallons per 24 hours.

The Cochituate conduit of the Boston water supply is 5 feet wide, 6'-4" high, of oviform section, and has an inclination of $3\frac{1}{8}$ inches to the mile. Its capacity is 16,500,000 gallons per 24 hours.

434. Foundations of Conduits.—The foundations of masonry conduits must be positively rigid, since the superstructures are practically inelastic, and any movement is certain to produce rupture. A crack below the water-line admits water into the foundation, and tends to soften or undermine the foundation, and to further settlement, and to additional leakage. So long as the foundation yields, the conduit cannot be maintained water-tight, for the settling away of the support at any point results in an undue transverse strain upon the shell, and the adhesion of the mortar to the masonry is overcome and the work cracks.

435. Conduit Shells.—A perfect shell should have considerable tensile strength in the direction of its circumference; but when a longitudinal crack is produced its tensile strength is destroyed at that point, and cannot again be fully restored except by rebuilding.

When the side walls are of rubble masonry they are usually lined with a course of brick-work laid in mortar, or with a smooth coat of hydraulic cement mortar. The bottoms are frequently lined with a nearly flat invert arch of brick.

All the materials and workmanship entering into this class of structures should be of superior quality.

436. Ventilation of Conduits.—Conduits of form and construction similar to those above illustrated are usually proportioned so that they are capable of delivering the maximum volume of water required when flowing about two-thirds full. Provision is then made for the free circulation of a stratum of air over the water surface and beneath the covering arch.

FIG. 90.

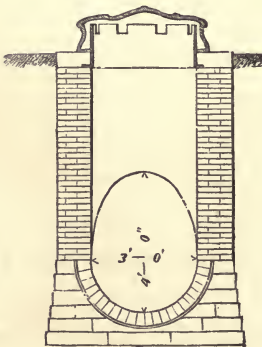
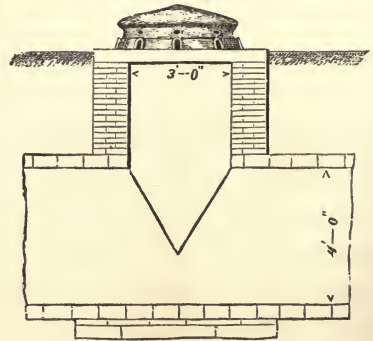

FIG. 91.



Figs. 90 and 91 illustrate the form of ventilating shaft and cover used upon the New Bedford, Mass., conduit.

These shafts may be used also for man-hole shafts, which are required at frequent intervals for inspection and care of the conduit.

FIG. 92.

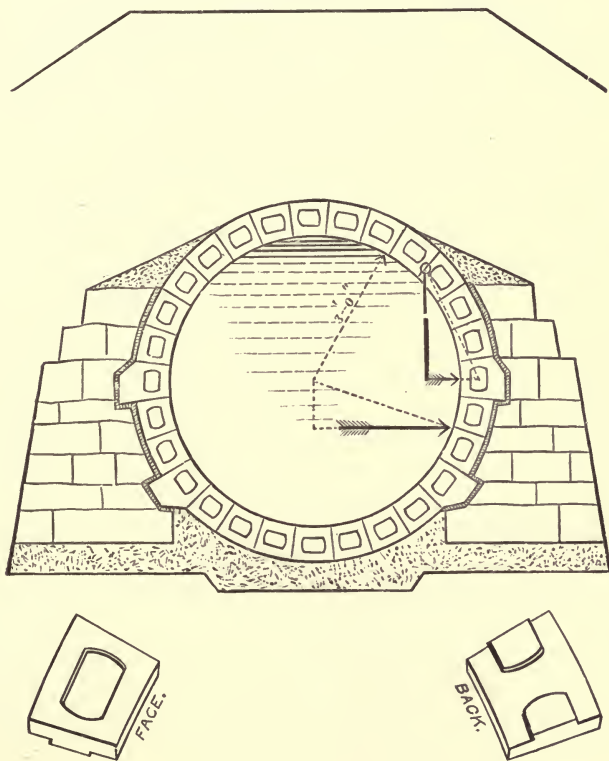

437. Conduits under Pressure.—Fig. 92 illustrates a conduit of locked bricks, designed by the writer to convey water under pressure. The specially moulded bricks are eight inches long and eight inches wide and two and one-half inches thick. They have upon one side a mortise six inches long, four and one-quarter inches wide, and one-half inch deep, and upon the opposite side two tenons, each matching in form a half mortise. When the bricks are laid

in the shell the tenons at the adjoining ends of two bricks fill the mortise in the brick over which the joint breaks.

In brick conduits as usually constructed the bricks have their greatest length in a longitudinal direction, but here the length is in circumferential direction. The object here is to utilize to the fullest extent the tensile bonding strength of the masonry, and then to reinforce this strength by interlocking the bricks themselves. The conduit cannot be ruptured by pressure of water without shearing off numerous tenons in addition to overcoming the cohesive strength of the masonry.

This system permits of vertical undulations in the grade of the conduit within moderate limits, and reduces materially the amount of lift of the conduit required upon embankments.

Upon long conduits it permits the insertion of stop-gates and the examination and repair of any one section while the other sections remain full of water. Also when of a given sectional area and flowing full, and delivering to a pump-well or directly into distribution-pipes a given volume of water, it transfers more of the pressure due to the head than the usual form of construction of like sectional area, and thus reduces the lift of the pump or increases the head upon the distribution. This is more especially the case when the consumption is less than the maximum.

438. Protection from Frost.—The masonry of conduits must be fully protected from frost, or its cement mortar will be seriously disintegrated by the freezing and expansion of the water filling its pores. The frost coverings are usually earthen embankments, of height above the top of the masonry equal to the greatest depth to which frost penetrates in the given locality. The level breadth of the

top of the embankment should equal the breadth of the conduit, and the side slopes be not less than $1\frac{1}{2}$ to 1.

439. Masonry to be Self-sustaining.—When the conduit is in part or wholly above ground surface, its masonry should be self-sustaining under the maximum pressure, independent of any support that may be expected from the embanked earth. The winds of winter generally clear the embankments very effectually of their snow coverings, and leave them exposed to the most intense action of frost. *weight above*

In periods of most excessive cold weather the entire embankment may be frozen into a solid arch, and by expansion rise appreciably clear of the masonry, and possibly exert some adhesive pull upon the hances of the arch. If the conduit is then under full pressure, and not wholly independent of earth support, a rupture at the crown of the arch may result.

Each quadrant of the covering arch, above its springing line, exerts a horizontal thrust at the springing line as indicated in Fig. 92 by the shorter arrow, and the water pressure exerts an additional horizontal thrust, as indicated by the lower arrow in Fig. 92. When the conduit is just even full, the point of mean intensity of this latter pressure is at one-third the height from the bottom of the conduit.

The amount of horizontal pressure upon each side in each unit of length is equal to the vertical projection of the submerged portion of that side, per unit of length into the vertical depth from free water surface, of the centre of gravity of the submerged surface, into the weight of one cubic foot of water; the depths being in feet, and weight and pressure in pounds.

The product of weight of backing masonry at any given depth below the crown of the arch into its coefficient of

friction, should be greater than the sum of thrusts at that depth, and for a safe margin to insure frictional stability should be equal to double the sum of thrusts.

The backing masonry is liable to receive some pull from

the embankment, if one side of the embankment settles or slides, but if the foundations of the sides of the embankments are reasonably firm, the earth at the sides of the backings may be assumed capable of neutralizing the thrusts due to the weight of covering earth upon the hances of the arch.

FIG. 93.

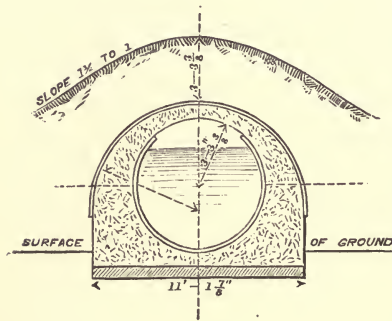

440. A Concrete Conduit.—The use of hydraulic concrete, or *beton*, is at present being more generally introduced* into American hydraulic constructions, in those localities where good quarried stones are not readily and cheaply accessible, than has been practiced in years past.

Fig. 93 is introduced here as a matter of especial interest, since it illustrates the form of a conduit constructed entirely of beton, in the new Vanne water supply for the city of Paris. This conduit is two meters (6.56 feet) in diameter.

The *beton aggloméré* of this conduit is a very superior quality of hydraulic concrete, which has resulted from the experiments and researches of M. Francois Coignet, of Paris.

Gen. Q. A. Gillmore has described* in Professional Papers, Corps of Engineers, U. S. Army, No. 19, the materials, compositions, manipulations, and properties of this

* Report on Beton Aggloméré, or Coignet Beton. Washington, 1871.

beton in a masterly manner, and has given several plates illustrating some of the magnificent monolithic aqueducts of concrete, spanning valleys and quicksands, in the great forest of Fontainebleau, on the line of the Vanne conduit, between La Vanne River and the city of Paris.

441. Example of Conduit under Heavy Pressure.

—The details of the Penstock, leading water from the canal above referred to (§ 382), to the Manchester, N. H., turbines and pumps, are shown in Fig. 94.

This penstock is six hundred feet long, and six feet clear internal diameter. Its axis at the upper end is under twelve feet head of water, and at the lower end under thirty-eight feet head of water. It was constructed, in place, in a trench averaging thirteen feet deep. The staves, which are of southern pitch-pine, 4 inches thick, were machine-dressed to radial lines, and laid so that each stave breaks joint at its end at a distance from the ends of the adjoining staves, after the usual manner of laying long floors. The end-joints where each two staves abut are closed by a plate of flat iron, one inch wide, let into saw-kerfs cut in the ends of the staves at right angles to radius. Thus a continuous cylinder is formed, except at the two points where changes of grade occur. The hoops are of $2\frac{1}{2} \times \frac{1}{2}$ -inch rolled iron, each made in two sections with clamping bolts, and they are placed at average distances of eighteen inches between centres.

Its capacity of delivery is sixty-five million gallons in twenty-four hours, with velocity of flow not exceeding four feet per second.* It was completed in the spring of 1874, and has since been in successful use, requiring no repairs. It lies in a ground naturally moist, and sufficiently satu-

* This penstock is more fully described in a paper read before the American Society of Civil Engineers in January, 1877. *Vide* Trans., March, 1877.

FIG. 94.

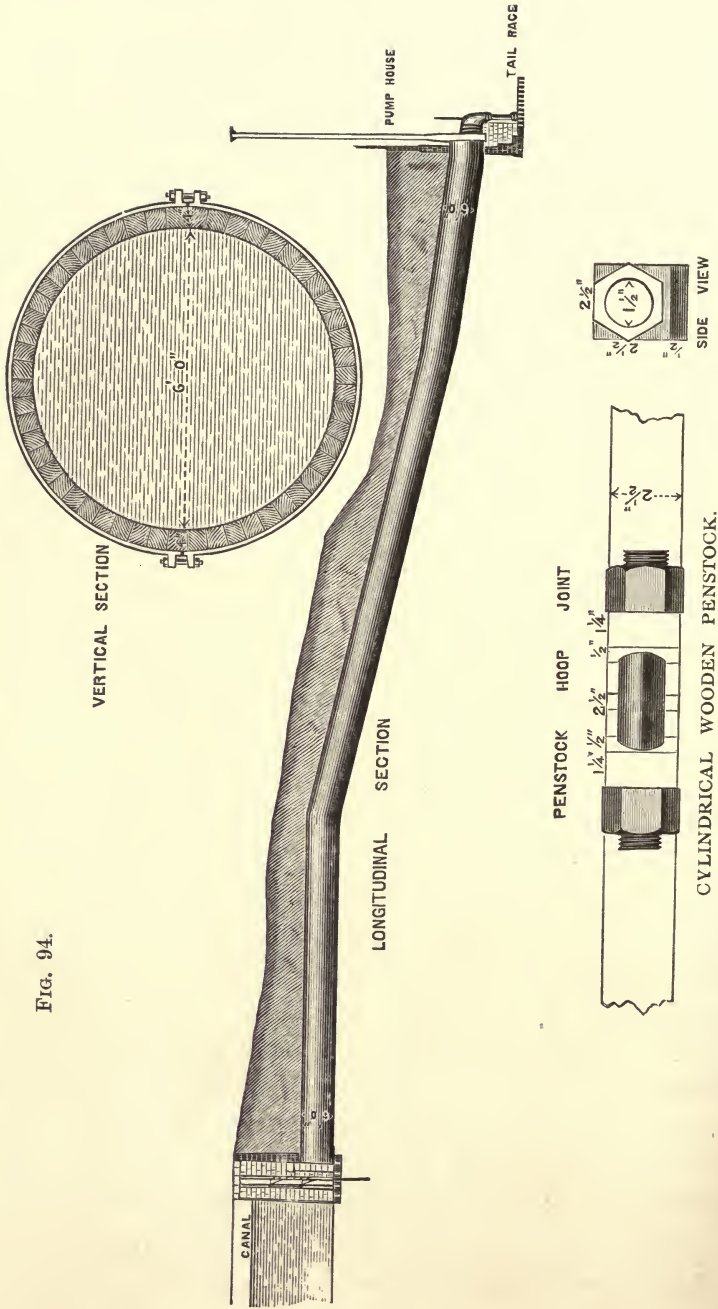

rated to fully protect the wood-work from the atmospheric gases.

The city of Toronto, Canada, has just completed a conduit of wood, which conveys water under pressure from the filtering gallery on an island in Lake Ontario, opposite to the city, about 7,000 feet, to the pumping-station on the main land. The internal diameter of this conduit is 4 feet.

442. Mean Radii of Conduits.—In the formula of flow for open canals (§ 323), the influence of the air perimeter is taken into consideration in establishing the value of the *hydraulic mean depth*, $r = \frac{\text{sectional area, } S}{\text{contour, } C}$, and a fractional portion of the air perimeter, equal to its proportional resistance, is added to the solid wet perimeter.

It is more especially necessary that the resistance of the air perimeter be recognized in conduits partially full. As the depth of water increases above half-depth, the influence of the confined air section is, apparently, inversely as the mean hydraulic radius of the stream.

If we compute, for circular conduits, values of r , as equal to $\frac{\text{section}}{\text{wet solid perimeter}}$, we have at 0 depth, $r = 0d$; at one-fourth depth, $r = .14734d$; at one-half depth, $r = .25d$; at three-fourths depth, $r = .30133d$; and at full depth, $r = .25d$. This series gives a maximum value of r at about eight-tenths depth and a decrease in its value from thence to full.

The relative discharging powers, in volume, of a circular conduit, with different depths of water, are as the product $S \sqrt{\frac{r}{m}}$, when S is the sectional area of the stream; r , the mean hydraulic radius; and m , a coefficient.

If for a given series of depths, in the same conduit, we compute its series of volumes of discharge, neglecting the

influence of the air perimeter, we arrive at the paradoxical result that when the depth is eighty-eight hundredths of full the volume flowing is ten per cent. greater than when the conduit is full. This theoretical result has misled several hydraulicians who have written upon the subject.

With a true value of r , the discharge has some ratio of increase so long as sectional area of column of water in a circular conduit increases; but the maximum capacity of discharge of a conduit is very nearly reached when it is seven-eighths full.

TABLE No. 90.

HYDRAULIC MEAN RADII FOR CIRCULAR CONDUITS, PART FULL.

(Expressed in decimal parts of the diameter.)

RATIO OF FULL DEPTH.																	
0	.1	.2	.25	.3	.4	.5	.55	.6	.65	.7	.75	.8	.85	.875	.9	.95	Full.
HYDRAULIC MEAN RADII, IN RATIO OF DIAMETER.																	
0	.058	.110	.136	.157	.200	.235	.250	.263	.272	.275	.278	.277	.273	.270	.265	.260	.250

443. Formulas of Flow, for Conduits.—Rankine's formula* for loss of head in an open conduit is,

$$h'' = \frac{ml}{r} \cdot \frac{v^2}{2g}, \quad (1)$$

from which, by transposition, we have the equation of velocity,

$$v = \left\{ \frac{2ghr}{ml} \right\}^{\frac{1}{2}} = \left\{ \frac{2gri}{m} \right\}^{\frac{1}{2}}. \quad (2)$$

For value of the coefficient m he adopts Weisbach's formula, viz. :

$$m = .0074 + \frac{.00023}{v}.$$

* Civil Engineering, p. 678. London, 1872.

This formula for m gives a constant value to m , while v remains constant, even though r varies. Experiment shows that the variable r exerts a very appreciable influence upon the value of the coefficient m , when

$$m = \frac{2gr i}{v^2}. \tag{3}$$

It is unfortunate that data for the construction of a table of m for conduits, not under pressure, is so scanty. Their values for brick conduits, or brick linings for a given series of r , evidently lie somewhere between the values of m for smooth pipes under pressure, and the values of m for straight open channels in earth.

The following column of values for the given series of r are suggested merely as approximate mean values for smooth conduits three-quarters full, and are placed between columns of values of m for smooth pipes under pressure, and for straight open channels in earth for convenience of ready comparison.

They are applicable to the formulas, for conduits :

$$v = \left\{ \frac{2gr i}{m} \right\}^{\frac{1}{2}} \tag{4}$$

$$h = \frac{ml}{r} \cdot \frac{v^2}{2g} \tag{5}$$

$$i = \frac{mv^2}{2gr}, \tag{6}$$

in which

v = velocity of flow, in feet per second.

r = hydraulic mean radius.

i = sine of inclination of water surface.

h = vertical head lost in given length, in feet.

l = given length, in feet.

TABLE No. 90a.

COEFFICIENTS FOR SMOOTH CONDUITS, THREE-QUARTERS FULL.

(For a mean velocity of about 2.5 feet per second.)

Hydraulic mean radii <i>r</i> in feet.	Coefficient <i>m</i> for smooth pipes, under pressure.	Coefficient <i>m</i> for smooth conduits, $= \frac{2gr_i}{v^2}$.	Coefficient <i>m</i> for open channels in earth.
1	.00380	.0100	.0298
1.25	.00342	.0084	.0260
1.50	.00325	.0071	.0234
1.75	.00300	.0063	.0212
2	.00281	.0057	.0197
2.25	.0027	.0053	.0183
2.50	.0026	.0050	.0172
2.75		.0048	.0161
3		.0046	.0153
3.25		.0045	.0143
3.50		.0044	.0131
3.75		.0042	.0137
4		.0040	.0127

A mean velocity of flow of about two and one-half feet per second is usually preferred in smooth conduits and supply mains, when local circumstances permit the inclination and sectional area to be adapted to this end. Less velocities, in conduits of three feet or more diameter, permits the waters to deposit the sediments they have in suspension.

444. Table of Conduit Data.—The following table gives such data as is at present obtainable respecting some of the well-known conduits of masonry :

TABLE No. 91.

CONDUIT DATA.

LOCALITY.	Width.	Height.	Depth of Water.	<i>r.</i>	<i>i.</i>	<i>v</i> per sec.	<i>m.</i>	Daily delivery at given depth.	Total daily capacity.
	<i>Feet.</i>	<i>Feet.</i>	<i>Feet.</i>			<i>Feet.</i>		<i>U.S. gal.</i>	<i>U.S. gal.</i>
Cochituate, Boston.....	5	6.333	6.333	1.417	.0000496	1.0	.00452	16,398,980	16,500,000
Croton, New York.....	7.417	8.458	6.083	2.3415	.00021	2.218	.006435	59,340,243	100,000,000
Washington Aq., D.C.....	9	9	3.465	1.8735	.00015	1.893	.00505	27,559,364	100,000,000
Brooklyn, L. I.....	10	8.667	5.00	2.5241	.0001	70,000,000
Sudbury, Boston.....	9	7.667	5.30002	70,000,000
Baltimore.....	9	9	170,000,000
Loch Katrine, Glasgow..	8	8	6.85	2.5253	.0001578	1.7126	.00876	60,000,000	60,000,000
Canal of Isabel II, Madrid	7.0522	9.184	52,000,000
Vienna.....	5.667	6.0000435
Vanne, Paris.....	6.6	6.6	5.000001	23,500,000
Dhuis, ".....	2.3	3.50001	5,500,000
Pont du Gard, Nimes.....	4.00	3.3330004	2
Pont Pyla, Lyons.....	1.833	1.83300166	2.95
Metz.....	3.167	2.167001	2.783
Arcueil.....0004
Roquencourt, Versailles..	3.925	2.5830003
Caserte, Naples.....0002	1.333
Montpellier.....	1	0.50003	.716

CHAPTER XXI.

MAINS AND DISTRIBUTION PIPES.

445. Static Pressures in Pipes.—Passing from the consideration of masonry conduits to that of pipes with tough metal shells, the pressure strains and the capabilities of resistance of the pipe metals to these strains, first demand our attention.

The theoretical relations of thickness to pressure are so simple that we may easily adapt any tough metal pipe to withstand any practical static head pressure, however great.

By the term *static pressure*, we indicate the full pressure due to the head of water, while standing at rest.

The unit of pressure area is commonly taken as one square inch, and this is the area used herein for the unit.

FIG. 95.

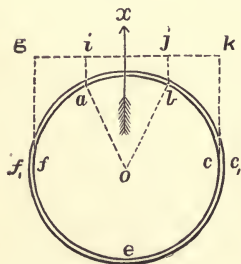

The pressure p upon the unit of area a_1 of a conduit or water-pipe, is equal to the product of the given area into the vertical height h of the surface of water above the centre of gravity of the given area, into the weight w of one cubic foot of water ($= 62.5$ lbs.) divided by 144.

$$p = \frac{a_1 \times h \times w}{144} = .434h. \quad (1)$$

Let $abcef$, Fig. 95, be the internal circumference of a

FIG. 96a.

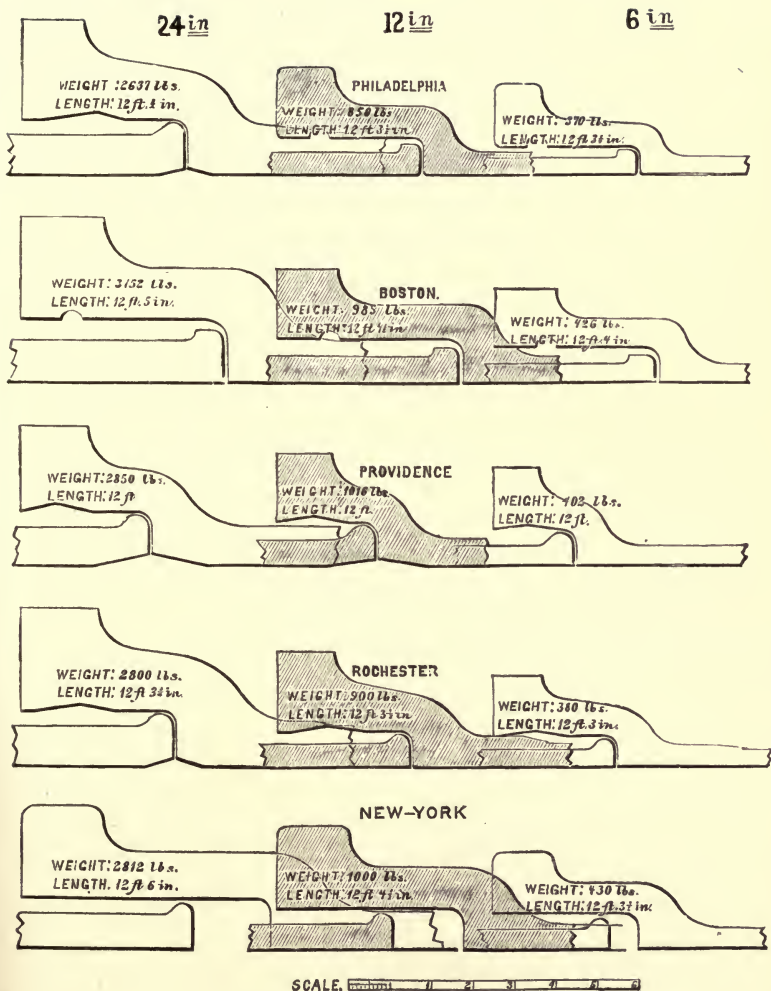

FORMS OF PIPE SOCKETS.

water-pipe, of diameter d , in inches ; then the total pressure P of water upon the circumference is

$$P = 3.1416d \times .434h. \quad (2)$$

The maximum pressure acts upon each point of the circumference radially outward, tending to tear the shell asunder.

The resultant of the maximum pressure upon any given portion of the circumference ab , acts in a radial direction ox , through the centre of gravity of the surface ab , and is equal to the product of pressure into the projection or trace of the surface ij , at right-angles to radius,

$$= \{ (\text{area } ij) \times p \}.$$

Also the resultant of the maximum pressure upon the semi-circumference $cbaf$ is equal to the product of pressure into its trace gk , at right-angles to the radial line cutting its centre of gravity,

$$= \{ (\text{area } gk) \times p \}.$$

The trace of the semi-circumference is also equal to the diameter d , and its resultant equals the product dp .

Opposed to the resultant ox is an equal resultant of the pressure upon the semi-circumference fec .

These two resultants exert their maximum tensile strain upon the pipe-shell at the points c and f .

446. Thickness of Shell resisting Static Pressure.

—Let S be the cohesive strength or ultimate tenacity per sq. in. of the metal of the shell, and t be the thickness cc_1 and ff_1 in inches of the shell, then we have for equation of resistance of shell that will *just balance* the steady static pressure,

$$2tS = dp. \quad (3)$$

from which we deduce the required thickness of shell :

$$t = \frac{dp}{2S} = \frac{rp}{S}, \quad (4)$$

in which r equals radius in inches, $= \frac{d}{2}$.

It is not enough that the shell be able to just sustain the steady static pressure, since this pressure may be increased by "*water-rams*," incident to ordinary or extraordinary use of the pipe, or the metal may have unseen weaknesses, or deteriorate by use.

The thickness t should therefore be multiplied by a coefficient, for safety, equal to 4, 6, 8, or 10; or the pressure be assumed to be increased 4, 6, 8, or 10 times, or the tenacity of the metal be taken at .1, .2, .3, or .4 of its test value; in which case the equation of t may take the form,

$$t = \frac{10pr}{S}; \quad \text{or} \quad t = \frac{pr}{.1S}. \quad (5)$$

The pressure due to a given head H of water is greater within a pipe when the water is at rest, than when the current is flowing through the pipe at a steady rate, for when the current is moving, a portion of the force of gravity is consumed in producing that motion, and in balancing frictions; hence the effective head H_1 remaining at a given point is less than the static head by an amount equal to the sum of the head to which the velocity is due ($= h = \frac{v^2}{2g}$), and the head overcoming the frictional resistances between the reservoir and the given point in the length of the pipe ($= h'' = \frac{ml}{r} \times \frac{v^2}{2g}$).

$$H_1 = H - (h + h''). \quad (\text{Vide } \S \text{ 265.})$$

When a pipe has a stop-valve at its outflow, or in its line, the pressure p , used in its formula of thickness t , for

any point above the valve, should be the static pressure of the water at rest.

447. Water-ram.—If any valve in a line or system of water-pipes can be suddenly closed while the water is flowing freely under pressure, such sudden closing of the valve will produce a strain upon the pipes far greater than that due to the static head of water.

For illustration, let any delivery-pipe, having a stop-valve at its outflow end, be 1 ft. diameter = d_1 , and 5280 ft. long = l , and the current of water filling it be flowing at a uniform rate v of 5 feet per second. Then the momentum M of this column of water, due to its weight and velocity, is

$$\begin{aligned} M &= .7854d_1^2 \times w \times l \times \frac{v^2}{2g} & (6) \\ &= .7854 \times 62.5 \times 5280 \times .3882 \\ &= 100,614.45 \text{ lbs.} \end{aligned}$$

If the valve is closed and the flow checked instantaneously, this great force will act upon the valve and upon the shell of the pipe. If the given *length* of column of water in motion is doubled or quadrupled, the force of the ram will be doubled or quadrupled. If the valve is one second or one minute in closing, then the force will be distributed through one second or one minute in time, and its intensity will be correspondingly reduced. Also, if there are any accumulations of air in the pipe at summits, they will help to prolong the time of action and to modify the force behind them.

No system of distribution-pipes should be fitted with stop-valves of instantaneous action, lest the pipes be constantly in danger of destruction by "*water rams.*"

Genieys made allowance, in the old water-pipes of Paris, for water-rams, of force equal to static heads of 500 feet,

but he used on his smaller mains plug-valves that might be very rapidly closed.

With proper stop and hydrant valves, it is not probable that the momentum strain will exceed that due to a steady static head of 200 or 225 feet, but it is liable to be great in pipes under low static heads as well as in pipes under great heads, and it is in either case in addition to the static head. The momentum strain must be fully allowed for, whether the head be ten feet or three hundred feet.

448. Formulas of Thickness for Ductile Pipes.—

Ordinarily, for ductile pipes, such as lead, brass, welded iron, etc., an allowance of from 200 to 300 feet head is made for the momentum strain, and the tenacity of the material is taken at .25 or .3 of its ultimate resistance S , in which

case the formula for thickness of *ductile pipes*, subject to water-ram, may take the form, $k = \frac{a \times h \times w}{144}$ $t = \frac{a h}{2 S}$

$$t = \frac{(h + 230 \text{ ft.}) r w}{(.25 S) \times 144} = \frac{(h + 230) d w}{(.5 S) \times 144} = \frac{(h + 230) d w}{72 S}, \quad (7)$$

in which h is the head of water, in feet.

w “ “ weight of one cubic foot of water, in lbs.

r “ “ radius of the pipe, in inches.

d “ “ diameter of the pipe, in inches.

t “ “ thickness of the pipe-shell, in inches.

S “ “ tenacity of the metal, per square inch.

If we substitute a term of pressure per square inch, p ($= .434h$), for $\frac{hw}{144}$ in the equation for thickness of *ductile pipes*, it becomes

$$t = \frac{(p + 100 \text{ pounds}) r}{.25 S} = \frac{(p + 100) d}{.5 S}. \quad (8)$$

If the pipes have merely a steady static pressure to sus-

tain, then the term + 100 may be omitted, and the equation, with factor of safety equal to 4, takes the simple form,

$$t = \frac{pr}{.25S} = \frac{pd}{.5S}, \tag{9}$$

or with factor of safety equal to 6,

$$t = \frac{pr}{.16667S} = \frac{pd}{.33333S}. \tag{10}$$

449. Strengths of Wrought Pipe Metals.—The following values of *S* give the tenacities of the respective materials named, in pounds *per square inch of section of metal*, when the metal is of good quality for pipes :

TABLE No. 92.

TENACITIES OF WROUGHT PIPE METALS.

	WEIGHT PER CU- BIC INCH.		COEF. 6 (<i>pr</i>).	COEF. 4 (<i>pr</i>).	COEF. 6 (<i>pd</i>).	COEF. 4 (<i>pd</i>).
	<i>Pounds.</i>	<i>S. in lbs.</i>	.16667 <i>S.</i>	.25 <i>S.</i>	.33333 <i>S.</i>	.5 <i>S.</i>
Lead.....	.4119	2,386	397.66	596.5	795.33	1193
Block tin.....	.2637	4,600	766.66	1150	1533.33	2300
Glass.....	.1046	9,400	1566.66	2350	3133.33	4700
Brass.....	.3000	28,000	4666.66	7000	9333.33	14000
Copper.....	.3146	30,000	5000	7500	10000	15000
Wrought-iron, single riveted.....	.2607	35,000	5833.33	8750	11666.66	17500
“ “ double “.....	.2607	40,000	6666.66	10000	13333.33	20000

CAST-IRON PIPES.

450. Moulding of Pipes.—The successful founding of good cast-iron pipes requires no inconsiderable amount of skill, such as is acquired only by long practical experience, and keen, watchful observation.

The loam and sand of the moulds and cores must be carefully selected for the best characteristics of grain, and

proportioned, combined, and moistened, so that the mixture shall be of the right consistency to form smooth and substantial moulds and cores, and be at the same time sufficiently porous to permit the free exit of moisture and steam during the process of drying. The moulds must be filled and rammed with a care that insures their stability during the inflow of the molten metal, and must be dried so there will be no further generation of steam during the inflow; and yet not be overdried so as to destroy the adhesion among their particles, lest the grains of sand be detached and scattered through the casting. The core roping of straw must be judiciously proportioned in thickness for the respective diameters of their finished cores, and must be twisted to a firmness that will resist the pressure of the molten metal, so that the pipe will be free from swells and the proper and uniform thickness of metal will be secured. The mixture of the metals and fuel in the cupola must be guided by that experience by which is acquired a foreknowledge of the degree of tenacity, elasticity, and general characteristics of the finished castings. A superior class of pipe is produced only when excellent materials are used, and when superior workmanship and mechanical appliances give to them accuracy of form and excellence of texture.

451. Casting of Pipes.—A certain thickness of shell, of twelve-foot pipes, cast vertically, is required for each diameter of pipe, to insure a perfect filling of the mould before the metal chills, or cools, and also to enable the pipes to be safely handled, transported, laid, and tapped.

In the smaller pipes this thickness is greater than that ordinarily required to sustain the static pressure of the water.

The necessary *additional* thickness, beyond that re-

quired to resist the water pressure, decreases as the diameter of the pipe increases.

There must, therefore, be affixed to the formula of thickness of cast-iron pipes, a term expressing the additional thickness required to be given to the pipes beyond that required to resist the pressure of the water, and this term must decrease in value as the diameter increases in value.

452. Formulas of Thickness of Cast-iron Pipes.

—The ultimate tenacity of good iron-pipe castings ranges from 16,000 to 29,000 pounds per square inch of section of metal. Their value of S , the symbol of tensile strength per square inch, is usually taken at 18,000 pounds, and the coefficient of safety equal to 10, or the term of tensile resistance is taken equal to $.1S$, or if an independent term is introduced in the formula for the effect of water-ram, the coefficient of S may be increased to, say $.2$.

Assuming that the probable or possible *water-ram* will not produce an additional effect greater than that due to a static pressure of 100 pounds per square inch, or head of 230 feet, then the formula for thickness of *cast-iron* pipes may take the form,

$$t = \frac{(h + 230)rw}{(.2S) \times 144} + .333 \left(1 - \frac{d}{100}\right) = \frac{(h + 230)dw}{(.4S) \times 144} + .333 \left(1 - \frac{d}{100}\right). \quad (11)$$

in which h is the head of water, in feet.

- w “ weight of one cubic foot of water, in lbs.
- r “ internal radius of the pipe, in inches.
- d “ internal diameter of the pipe, in inches.
- t “ thickness of the pipe shell, in inches.
- S “ tenacity of the metal, in pounds per sq. in.

If we substitute a term of pressure per square inch,

$p (= .434h)$ for $\frac{hw}{144}$, in the above equations for thickness of cast-iron pipes, they become,

$$t = \frac{(p + 100)r}{.2S} + .333 \left(1 - \frac{d}{100}\right) = \frac{(p + 100)d}{.4S} + .333 \left(1 - \frac{d}{100}\right). \quad (12)$$

453. Thicknesses found Graphically.—Since with a constant head, pressure, or assumed static strain, the increase of tensile strain upon the shell is proportional with the increase of diameter, and also since the decrease of additional thickness is proportional with the increase of diameter, it is evident that if we compute the thickness of a series of pipes, say from 4-inch to 48-inch diameters, for a given pressure, by a theoretically correct formula, and then plot to scale the results, with diameters as abscissas and thicknesses as ordinates, the extremes of all the ordinates will lie in one straight line; and also, that if the thicknesses for the minimum and maximum diameters of the series be computed and plotted as ordinates, in the same manner, and their extremities be connected by a straight line, the intermediate ordinates, or thicknesses for given diameters as abscissas, will be given to scale. This method greatly facilitates the calculation of thicknesses of a series of “classes” of pipes, and if the ordinates are plotted to large scale, gives a close approximation to accuracy.

454. Table of Thicknesses of Cast-iron Pipes.—The following table gives thicknesses of good, tough, and elastic cast-iron, with $S = 18,000$ lbs., for three classes of cast-iron pipes, covering the ordinary range of static pressures of public water supplies.

The thicknesses in the table are based upon the formula,

$$t = \frac{(p + 100)d}{.4S} + .333 \left(1 - \frac{d}{100}\right).$$

TABLE No. 93.
THICKNESSES OF CAST-IRON PIPES.

(When $S = 18000$ lbs.)

DIAMETER.	CLASS A. Pressure, 50 lbs. per square inch, or less. Head, 116 feet.		CLASS B. Pressure, 100 lbs. per square inch. Head, 230 feet.		CLASS C. Pressure, 130 lbs. per square inch. Head, 300 feet.	
	THICKNESSES.		THICKNESSES.		THICKNESSES.	
<i>Inches.</i>	<i>Inches.</i>	<i>Ap- prox. in.</i>	<i>Inches.</i>	<i>Ap- prox. in.</i>	<i>Inches.</i>	<i>Ap- prox. in.</i>
3	.3858	$\frac{13}{32}$.4066	$\frac{13}{32}$.4191	$\frac{7}{16}$
4	.4033	$\frac{13}{32}$.4311	$\frac{7}{16}$.4477	$\frac{7}{16}$
6	.4383	$\frac{7}{16}$.4800	$\frac{1}{2}$.5050	$\frac{1}{2}$
8	.4734	$\frac{1}{2}$.5289	$\frac{17}{32}$.5622	$\frac{9}{16}$
10	.5083	$\frac{1}{2}$.5777	$\frac{19}{32}$.6194	$\frac{5}{8}$
12	.5433	$\frac{9}{16}$.6266	$\frac{5}{8}$.6766	$\frac{11}{16}$
14	.5783	$\frac{19}{32}$.6755	$\frac{11}{16}$.7338	$\frac{3}{4}$
16	.6166	$\frac{5}{8}$.7277	$\frac{3}{4}$.7944	$\frac{13}{16}$
18	.6483	$\frac{23}{32}$.7733	$\frac{25}{32}$.8483	$\frac{27}{32}$
20	.6833	$\frac{11}{16}$.8222	$\frac{27}{32}$.9055	$\frac{29}{32}$
22	.7183	$\frac{23}{32}$.8711	$\frac{7}{8}$.9628	$\frac{31}{32}$
24	.7533	$\frac{3}{4}$.9200	$\frac{15}{16}$	1.0200	1
27	.8058	$\frac{13}{16}$.9933	1	1.1058	$1\frac{3}{32}$
30	.8583	$\frac{7}{8}$	1.0666	$1\frac{1}{16}$	1.1916	$1\frac{3}{16}$
33	.9108	$\frac{15}{16}$	1.1400	$1\frac{5}{32}$	1.2775	$1\frac{9}{32}$
36	.9633	$\frac{31}{32}$	1.2133	$1\frac{7}{32}$	1.3633	$1\frac{3}{8}$
40	1.0333	$1\frac{1}{32}$	1.3111	$1\frac{5}{16}$	1.4778	$1\frac{5}{32}$
44	1.1033	$1\frac{1}{8}$	1.4088	$1\frac{13}{32}$	1.5921	$1\frac{19}{32}$
48	1.1733	$1\frac{3}{16}$	1.5066	$1\frac{1}{2}$	1.7066	$1\frac{11}{16}$

In the following table are given the thicknesses of cast-iron pipes, as used by various water departments.

TABLE No. 93a.
THICKNESSES OF CAST-IRON PIPES, AS USED IN SEVERAL CITIES.

DIAMETER, INCHES.	PHILADELPHIA.	NEW YORK.	BALTIMORE.	BROOKLYN.	ST. LOUIS.	CHICAGO.	CLEVELAND.	PROVIDENCE.	LOWELL.	ROCHESTER.	FALL RIVER.	ALLEGHENY.	DETROIT.	ALBANY.	MILWAUKEE.	DIAMETER, INCHES.
	Head Pressures for which Pipes are Classed, in feet.															
	115	100	218	120	130	125	150	100	130	150	80	162	100	144	150	
	250	170	170	140	170	200	140	200	200	
	198	180	200	260	
Thicknesses of Pipe Shells, in inches.																
4	$\frac{3}{8}$	$\frac{7}{16}$	$\frac{1}{2}$	$\frac{1}{2}$	$\frac{1}{2}$	$\frac{1}{2}$	$\frac{3}{8}$	$\frac{1}{2}$	$\frac{7}{16}$	$\frac{1}{2}$	4
6	$\frac{7}{16}$	$\frac{1}{2}$	$\frac{7}{16}$	$\frac{9}{16}$	$\frac{13}{16}$	$\frac{1}{2}$	$\frac{1}{2} +$	$\frac{1}{2}$	$\frac{7}{16}$	$\frac{3}{8}$	$\frac{15}{16}$	$\frac{1}{2}$	$\frac{7}{16}$	$\frac{1}{2}$	$\frac{15}{16}$	6
6	$\frac{21}{32}$	$\frac{1}{2}$	$\frac{1}{2}$	$\frac{1}{2}$	$\frac{7}{16}$	$\frac{3}{8}$	$\frac{3}{8}$	$\frac{1}{2}$	6
8	$\frac{7}{16} +$	$\frac{1}{2}$	$\frac{1}{2}$	$\frac{1}{2}$	$\frac{1}{2}$	$\frac{1}{2}$	$\frac{1}{2}$	$\frac{1}{2}$	$\frac{7}{16}$	$\frac{13}{16}$	$\frac{3}{8}$	$\frac{1}{2}$	$\frac{1}{2}$	$\frac{1}{2}$	8
8	$\frac{21}{32}$	$\frac{5}{8} +$	$\frac{9}{16}$	$\frac{9}{16}$	$\frac{3}{4}$	$\frac{3}{8}$	$\frac{9}{16}$	8
10	$\frac{1}{2}$	$\frac{1}{2}$	$\frac{5}{8}$	$\frac{5}{8}$	$\frac{5}{8}$	$\frac{13}{16}$	$\frac{3}{4}$	$\frac{13}{16}$	$\frac{1}{2}$	$\frac{3}{8}$	10
12	$\frac{9}{16}$	$\frac{3}{8}$	$\frac{11}{16}$	$\frac{5}{8}$	$\frac{13}{16}$	$\frac{13}{16}$	$\frac{13}{16}$	$\frac{1}{2}$	$\frac{13}{16}$	$\frac{13}{16}$	$\frac{5}{8}$	$\frac{3}{4}$	$\frac{9}{16}$	$\frac{3}{8}$	$\frac{9}{16}$	12
12	$\frac{13}{16}$	$\frac{13}{16}$	$\frac{13}{16}$	$\frac{5}{8} +$	I	$\frac{15}{16}$	$\frac{3}{8}$	$\frac{5}{8}$	12
16	$\frac{5}{8}$	$\frac{3}{4}$	$\frac{13}{16}$	$\frac{7}{8}$	$\frac{3}{4} +$	$\frac{13}{16}$	$\frac{11}{16}$	$\frac{3}{4}$	$\frac{3}{4}$	$\frac{3}{4}$	$\frac{5}{8}$	$\frac{3}{4}$	$\frac{11}{16}$	16
16	$\frac{3}{4}$	$\frac{3}{4}$	I	$\frac{11}{16}$	$\frac{3}{4}$	16
20	$\frac{11}{16}$	$\frac{3}{4}$	$\frac{15}{16}$	$\frac{7}{8}$	$\frac{13}{16}$	$\frac{7}{8}$	$\frac{13}{16}$	$\frac{3}{4}$	$\frac{7}{8}$	I	$\frac{3}{4}$	$\frac{3}{4}$	20
20	I	$\frac{15}{16} +$	$\frac{13}{16}$	I	$\frac{15}{16}$	$\frac{7}{8}$	$\frac{7}{8}$	20
24	$\frac{7}{8}$	$\frac{7}{8} +$	$\frac{13}{16}$	$\frac{13}{16}$	$\frac{3}{4}$	$\frac{3}{4}$	I	$\frac{15}{16}$	24
24	$\frac{15}{16}$	$\frac{15}{16} +$	I	I	I	24
30	$\frac{15}{16}$	I	$\frac{11}{8}$	$\frac{13}{16}$	$\frac{13}{16}$	$\frac{11}{8}$	$\frac{13}{16}$	$\frac{15}{16} +$	$\frac{7}{8}$	$\frac{11}{8}$	I	30
30	$\frac{13}{16}$	$\frac{11}{8}$	I	$\frac{11}{8}$	$\frac{11}{16}$	30
30	$\frac{11}{16}$	$\frac{15}{16}$	$\frac{11}{8}$	30
36	$\frac{11}{8}$	I	$\frac{11}{8}$	$\frac{11}{8} +$	$\frac{11}{16}$	I	$\frac{11}{8}$	I	36
36	$\frac{15}{16}$	$\frac{11}{4}$	36
48	$\frac{11}{4}$	$\frac{5}{16}$	$\frac{5}{8}$	48

455. Table of Equivalent Fractional Expressions.

—The following tables of equivalent expressions for fractions of an inch and of a foot, may facilitate pipe calculations :

TABLE No. 94.

PARTS OF AN INCH AND A FOOT, EXPRESSED DECIMALLY.

INCHES.	Equivalent Dec. part of an inch.	Equivalent Dec. part of a foot.			
1-32	.03125	.002604			
1-16	.06250	.005208			
3-32	.09375	.007812			
1-8	.12500	.010416			
5-32	.15625	.010420			
3-16	.18750	.015625			
7-32	.21875	.018229			
1-4	.25000	.020833			
9-32	.28125	.023437			
5-16	.31250	.026041			
11-32	.34375	.028645			
3-8	.37500	.031250			
13-32	.40625	.033854			
7-16	.43750	.036458			
15-32	.46875	.039062			
1-2	.50000	.041666			
17-32	.53125	.044270			
9-16	.56250	.046875			
19-32	.59375	.049479			
5-8	.62500	.052083			
21-32	.65625	.054607			
11-16	.68750	.057291			
23-32	.71875	.059895			
3-4	.75000	.062500			
25-32	.78125	.065104			
13-16	.81250	.067708			
27-32	.84375	.070312			
7-8	.87500	.072916			
29-32	.90625	.075520			
15-16	.93750	.078125			
31-32	.96875	.080729			
1	1.	.083333			

INCHES.	Equivalent Dec. parts of a foot.	Dec. parts of a foot.	Equip. inches and ³² d pts., nearly.
1	.0833	.1	1 ⁸ / ₁₆
2	.1667	.2	2 ³ / ₁₆
3	.2500	.3	3 ³ / ₁₆
4	.3333	.4	4 ³ / ₁₆
5	.4167	.5	5 ³ / ₁₆
6	.5000	.6	6 ³ / ₁₆
7	.5833	.7	7 ³ / ₁₆
8	.6667	.8	8 ³ / ₁₆
9	.7500	.9	9 ³ / ₁₆
10	.8333	1.0	10 ³ / ₁₆
11	.9167		11 ³ / ₁₆
12	1.0000		12 ³ / ₁₆

456. Cast-Iron Pipe Joints.—According to Crecy,* cast-iron pipes were first generally adopted in London very near the close of the last century. The great fire destroyed many of the lead mains in that city. These were in part replaced by wood pipes, but when water-closets were introduced and more pressure was demanded, the renewals were afterward wholly of iron.

* Encyclopedia of Civil Engineering, p. 549. London, 1865.

The earliest pipes had flanged joints with a packing ring of leather, and were bolted together. These were two and one-half feet in length. Those first generally used by the New River Company were somewhat longer, and were screwed rigidly together at the joints. This prevented their free expansion* and contraction, with varying temperatures of water and earth, rendering them troublesome in winter, when they were frequently ruptured. Cylindrical socket-joints were then substituted. These were accurately turned in a lathe, to a slightly conical form, and, being luted with a little whiting and tallow, were driven together.

The length of the pipes was subsequently increased to nine feet, and a hub and spigot-joint formed, adapted first to a joint packing of deal wedges, and afterward to a packing of lead.

The hub and spigot-joint, with various slight modifications, has been generally adopted in the British and continental pipe systems, for both water and gas pipes; but the turned joint has by no means been entirely superseded in European practice.

A variety of the forms given to the turned joint are illustrated and commented upon in a paper† recently read by Mr. Downie in Edinburgh. The illustrations include turned joints used in Glasgow, Launceston, Dundee, Flyde, Liverpool, Trieste, Sydney, Hobart Town, and Hamilton (Canada) water-works, and in the Buenos Ayres gas-works. These joints were also used by Mr. George H. Norman, the well-known American contractor for water and gas works, in gas works constructed by him in Cuba.

* M. Girard found that the lineal expansion of cast-iron pipes, when free and in the open air was .000036 of an inch for each additional degree of Fahrenheit.

† Proceedings Inst. E. S., vol. vii, p. 16.

The turned joint has not as yet been adopted in the pipe systems in the United States; but in the new water-work of Ottawa, Canada, completed in 1875 under the direction of Thos. C. Keefer, C.E., they were very generally used.

The depths of hub and of lead packing in the early English and Scotch pipes, and in fact in the first pipes used in connection with the Fairmount, Croton, and Washington aqueducts, exceeded greatly the depths at present used.

The pine-log water-pipes of Philadelphia had been generally replaced by cast-iron pipes as early as about 1819. The forms of hubs and spigots then used, as designed by Mr. Graffe, Sr., were very similar to those now used, except that the hubs had somewhat greater depth. The lengths of the pipes were nine feet, and other dimensions as in the following table, from data in the "Journal of the Franklin Institute":

Diameter of pipe, in inches.	3	4	6	8	10	12	16	20
Thickness of shell.....	$\frac{3}{8}$	$\frac{7}{16}$	$\frac{7}{16}$	$\frac{1}{2}$	$\frac{1}{2}$	$\frac{9}{16}$	$\frac{5}{8}$	$\frac{3}{4}$
Depth of hub.....	$3\frac{3}{8}$	4	$4\frac{1}{2}$	5	5	$5\frac{1}{2}$	6	6

It is observed that the set, by which the lead is compacted in the joint, acts upon the lead, ordinarily only to a depth of from one to one and one-quarter inches. The lead beyond the action of the set is of but little practical value, and there is no advantage in giving the hemp packing an excessive depth.

Deep joints run solid with lead often give to the line of pipes such rigidity that it cannot accommodate itself to the unevenness of its bearings and weight of backfilling, especially in ledge cuttings, and rupture results.

When trenches are too wet to admit of pouring the lead successfully, small, soft lead pipe may be pressed into the joint and faithfully set up with good effect.

457. Dimensions of Pipe-joints.—Fig. 96 is a re-

FIG. 96.

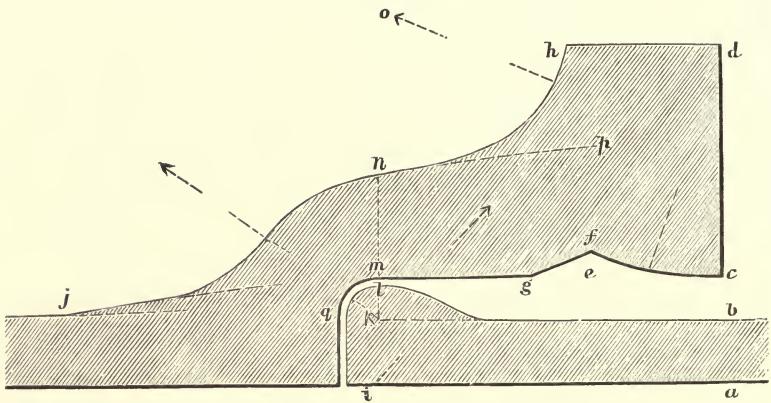

duced section of a bell and spigot of a 12-inch diameter pipe. Dimensions of cast-iron pipe socket-joints for diameters from 4-inch to 48-inch, corresponding to the letters in the sketch, are given in the following table (No. 95), and like data are given for flange-joints in the next succeeding table, No. 96.

The weight of flanged pipes, per lineal foot, exclusive of weight of flanges, which is given in Table No. 96, may be computed by the following formula (*vide* § 461) :

$$w = 9.817 (d + t) t. \quad (13)$$

458. Templets for Bolt Holes.—A sheet-metal templet for marking centres of bolt holes on flanges should be laid out and pricked with the nicest accuracy, and have its face side and one hole conspicuously marked.

On special castings intended for fixed positions the templet should be placed upon the flange so that the centre of the marked hole shall fix the position of one bolt hole exactly over the centre of the bore of the pipe when the pipe shall be placed in position, then the bolt holes of abutting flanges will match with uniformity.

TABLE No. 95.

DIMENSIONS OF CAST-IRON WATER-PIPES. (Fig. 96.)

(Thickness of shell is herein proportioned for 100 lbs. static pressure.)

Diameter.	Length over all.	Thickness of shell.	Depth of hub.	Joint room.	cd	dh	ce	eg	ef	fp	kl	km	mn	ho	qj
<i>in.</i>	' "	" "	" "	" "	" "	" "	" "	" "	" "	" "	" "	" "	" "	" "	" "
4	12-3	$\frac{7}{16}$	3	$\frac{5}{16}$	$1\frac{1}{2}$	$1\frac{1}{4}$	$1\frac{1}{8}$	$\frac{1}{2}$	$\frac{3}{16}$	$\frac{3}{4}$	$\frac{1}{4}$	$\frac{5}{16}$	$\frac{3}{4}$	$\frac{7}{8}$	2
6	12-3	$\frac{1}{2}$	3	$\frac{5}{16}$	$1\frac{5}{8}$	$1\frac{1}{4}$	$1\frac{1}{8}$	$\frac{1}{2}$	$\frac{3}{16}$	$\frac{3}{4}$	$\frac{1}{4}$	$\frac{5}{16}$	$\frac{3}{4}$	1	2
8	12-3	$\frac{17}{32}$	3	$\frac{5}{16}$	$1\frac{3}{8}$	$1\frac{1}{4}$	$1\frac{1}{8}$	$\frac{1}{2}$	$\frac{3}{16}$	$\frac{3}{4}$	$\frac{1}{4}$	$\frac{5}{16}$	$\frac{3}{4}$	$1\frac{1}{8}$	$2\frac{1}{4}$
10	12-3	$\frac{19}{32}$	3	$\frac{5}{16}$	$1\frac{7}{8}$	$1\frac{1}{4}$	$1\frac{1}{8}$	$\frac{1}{2}$	$\frac{3}{16}$	$\frac{3}{4}$	$\frac{1}{4}$	$\frac{5}{16}$	$\frac{3}{4}$	$1\frac{1}{8}$	$2\frac{1}{4}$
12	12-3 $\frac{1}{4}$	$\frac{5}{8}$	3 $\frac{1}{4}$	$\frac{5}{16}$	2	$1\frac{3}{8}$	$1\frac{1}{8}$	$\frac{1}{2}$	$\frac{3}{16}$	$\frac{7}{8}$	$\frac{1}{4}$	$\frac{5}{16}$	$\frac{7}{8}$	$1\frac{1}{4}$	$2\frac{1}{2}$
14	12-3 $\frac{1}{4}$	$\frac{11}{16}$	3 $\frac{1}{4}$	$\frac{5}{16}$	$2\frac{1}{8}$	$1\frac{3}{8}$	$1\frac{1}{8}$	$\frac{1}{2}$	$\frac{3}{16}$	$\frac{7}{8}$	$\frac{1}{4}$	$\frac{5}{16}$	$\frac{7}{8}$	$1\frac{1}{4}$	$2\frac{1}{2}$
16	12-3 $\frac{1}{2}$	$\frac{3}{4}$	3 $\frac{1}{2}$	$\frac{3}{8}$	$2\frac{1}{8}$	$1\frac{5}{8}$	$1\frac{3}{16}$	$\frac{5}{8}$	$\frac{1}{4}$	$\frac{7}{8}$	$\frac{5}{16}$	$\frac{3}{8}$	$\frac{7}{8}$	$1\frac{1}{2}$	$2\frac{3}{4}$
18	12-3 $\frac{1}{2}$	$\frac{35}{64}$	3 $\frac{1}{2}$	$\frac{3}{8}$	$2\frac{1}{4}$	$1\frac{5}{8}$	$1\frac{3}{16}$	$\frac{5}{8}$	$\frac{1}{4}$	$\frac{7}{8}$	$\frac{5}{16}$	$\frac{3}{8}$	$\frac{7}{8}$	$1\frac{1}{2}$	$2\frac{3}{4}$
20	12-3 $\frac{3}{4}$	$\frac{7}{8}$	3 $\frac{3}{4}$	$\frac{3}{8}$	$2\frac{1}{4}$	$1\frac{5}{8}$	$1\frac{3}{16}$	$\frac{5}{8}$	$\frac{1}{4}$	$\frac{7}{8}$	$\frac{5}{16}$	$\frac{3}{8}$	$\frac{7}{8}$	$1\frac{1}{2}$	$2\frac{3}{4}$
22	12-3 $\frac{3}{4}$	$\frac{7}{8}$	3 $\frac{3}{4}$	$\frac{3}{8}$	$2\frac{1}{2}$	$1\frac{3}{4}$	$1\frac{3}{16}$	$\frac{5}{8}$	$\frac{1}{4}$	1	$\frac{5}{16}$	$\frac{3}{8}$	1	$1\frac{5}{8}$	3
24	12-3 $\frac{3}{4}$	$\frac{15}{16}$	3 $\frac{3}{4}$	$\frac{3}{8}$	$2\frac{1}{2}$	$1\frac{3}{4}$	$1\frac{3}{16}$	$\frac{5}{8}$	$\frac{1}{4}$	1	$\frac{5}{16}$	$\frac{3}{8}$	1	$1\frac{5}{8}$	3
27	12-4	1	4	$\frac{7}{16}$	$2\frac{3}{4}$	$1\frac{7}{8}$	$1\frac{1}{4}$	$\frac{3}{4}$	$\frac{1}{4}$	$1\frac{1}{8}$	$\frac{3}{8}$	$\frac{7}{16}$	$1\frac{1}{8}$	$1\frac{3}{4}$	$3\frac{1}{4}$
30	12-4	$1\frac{1}{16}$	4	$\frac{7}{16}$	$2\frac{3}{4}$	$1\frac{7}{8}$	$1\frac{1}{4}$	$\frac{3}{4}$	$\frac{1}{4}$	$1\frac{1}{8}$	$\frac{3}{8}$	$\frac{7}{16}$	$1\frac{1}{8}$	$1\frac{3}{4}$	$3\frac{1}{4}$
33	12-4 $\frac{1}{4}$	$1\frac{5}{32}$	4 $\frac{1}{4}$	$\frac{7}{16}$	$2\frac{3}{4}$	2	$1\frac{1}{4}$	$\frac{3}{4}$	$\frac{1}{4}$	$1\frac{1}{8}$	$\frac{3}{8}$	$\frac{7}{16}$	$1\frac{1}{8}$	$1\frac{7}{8}$	$3\frac{1}{2}$
36	12-4 $\frac{1}{4}$	$1\frac{7}{32}$	4 $\frac{1}{4}$	$\frac{1}{2}$	$2\frac{3}{4}$	2	$1\frac{1}{4}$	$\frac{3}{4}$	$\frac{1}{4}$	$1\frac{1}{8}$	$\frac{7}{16}$	$\frac{1}{2}$	$1\frac{1}{8}$	$1\frac{7}{8}$	$3\frac{1}{2}$
40	12-4 $\frac{1}{2}$	$1\frac{5}{16}$	4 $\frac{1}{2}$	$\frac{1}{2}$	$2\frac{3}{4}$	$2\frac{1}{8}$	$1\frac{1}{4}$	$\frac{3}{4}$	$\frac{1}{4}$	$1\frac{1}{4}$	$\frac{7}{16}$	$\frac{1}{2}$	$1\frac{1}{4}$	2	$3\frac{3}{4}$
44	12-4 $\frac{5}{8}$	$1\frac{33}{64}$	4 $\frac{5}{8}$	$\frac{1}{2}$	$2\frac{7}{8}$	$2\frac{1}{8}$	$1\frac{1}{4}$	$\frac{3}{4}$	$\frac{1}{4}$	$1\frac{1}{4}$	$\frac{7}{16}$	$\frac{1}{2}$	$1\frac{1}{4}$	2	$3\frac{3}{4}$
48	12-4 $\frac{3}{4}$	$1\frac{1}{2}$	4 $\frac{3}{4}$	$\frac{1}{2}$	3	$2\frac{1}{4}$	$1\frac{1}{4}$	$\frac{3}{4}$	$\frac{1}{4}$	$1\frac{3}{8}$	$\frac{7}{16}$	$\frac{1}{2}$	$1\frac{3}{8}$	2	4

TABLE No. 96.

FLANGE DATA OF FLANGED CAST-IRON PIPES.

Diam. of bore of pipe.	Diameter of flange.	Thick-ness of flange.	Approx. weight of one flange.	No. of bolts.*	Diam. of bolts.	Diameter of circle of bolts.	Distance between centres of bolts.	Common diam. of valve flanges.
<i>Inches.</i>	<i>Inches.</i>	<i>Inches.</i>	<i>Pounds.</i>		<i>Inches.</i>	<i>Decimal inches.</i>	<i>Decimal inches.</i>	<i>Inches.</i>
3	6 $\frac{1}{2}$	$\frac{11}{16}$	3.45	8	$\frac{7}{16}$	5.6	2.199	8
4	7 $\frac{3}{4}$	$\frac{3}{4}$	6.64	10	$\frac{1}{2}$	6.7	2.105	9
6	10	$\frac{13}{16}$	8.56	10	$\frac{9}{16}$	8.9	2.796	11
8	12 $\frac{3}{8}$	$\frac{13}{16}$	11.98	12	$\frac{5}{8}$	11.1	2.906	13
10	14 $\frac{5}{8}$	$\frac{7}{8}$	16.5	14	$\frac{3}{4}$	13.3	2.985	16
12	17	$\frac{15}{16}$	22.3	14	$\frac{3}{4}$	15.5	3.478	18
14	19 $\frac{1}{4}$	1	28.6	16	$\frac{3}{4}$	17.75	3.485	20
16	21 $\frac{5}{8}$	$1\frac{1}{16}$	36.8	18	$\frac{3}{4}$	20.0	3.491	22
18	23 $\frac{7}{8}$	$1\frac{1}{8}$	45.5	20	$\frac{3}{4}$	22.2	3.487	24
20	26 $\frac{1}{4}$	$1\frac{3}{16}$	56.9	20	$\frac{3}{4}$	24.4	3.833	26 $\frac{1}{4}$
22	28 $\frac{1}{4}$	$1\frac{1}{4}$	62.8	22	$\frac{3}{4}$	26.5	3.784	28 $\frac{1}{4}$
24	30 $\frac{3}{8}$	$1\frac{1}{4}$	65.4	24	$\frac{7}{8}$	28.6	3.744	30 $\frac{3}{8}$
27	33 $\frac{5}{8}$	$1\frac{5}{16}$	80.8	26	$\frac{7}{8}$	31.8	3.842	33 $\frac{5}{8}$
30	36 $\frac{3}{4}$	$1\frac{3}{8}$	95.9	28	$\frac{7}{8}$	35.0	3.927	36 $\frac{3}{4}$
33	40	$1\frac{1}{2}$	117	30	$\frac{7}{8}$	38.1	3.990	40
36	43 $\frac{1}{2}$	$1\frac{9}{16}$	143	32	$\frac{7}{8}$	41.6	4.084	43 $\frac{1}{2}$
40	47 $\frac{5}{8}$	$1\frac{5}{8}$	160	34	$\frac{7}{8}$	45.75	4.227	47 $\frac{5}{8}$
44	51 $\frac{7}{8}$	$1\frac{3}{4}$	197	36	$\frac{7}{8}$	50.0	4.363	51 $\frac{7}{8}$
48	56	$1\frac{7}{8}$	224	40	$\frac{7}{8}$	54.1	4.249	56

* The number of bolts given in the table may be decreased when the water pressures and transverse strains upon the bolts are light.

If an even number of bolts are used, then there will be a bolt vertically over and under the centre of the bore of the pipe.

If the templet is not very exactly spaced the face side should be placed against one flange with the marked hole at top, and the back against the other abutting flange with same hole at top; otherwise the bolt holes may not exactly match.

459. Flexible Pipe-Joint.—It is sometimes necessary to take a main or sub-main across a broad, deep stream or

FIG. 97.

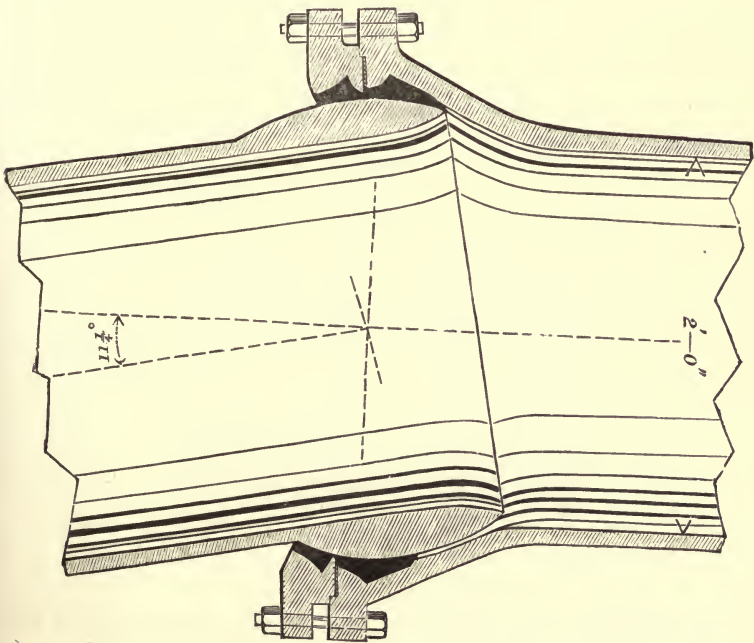

estuary, or arm of a lake, where it is both difficult and expensive to coffer a pipe course so as to make the usual form of rigid joint. Different forms of *ball* and *socket*

flexible joints have been adopted for such cases, which allow the pipes to be joined and the joints completed above the water surface, and the pipe then to be lowered into its bed.

Fig. 97 illustrates the form of joint designed by the writer for a twenty-four inch pipe, which is especially adapted to large-size pipe-joints. It is a modification of the Glasgow "universal joint."

The difficulty of making the back part of the lead-packing of the joint firm and solid, which difficulty has heretofore interfered with the complete success of the larger flexible pipes, is here overcome by separating the bell into two parts, so as to permit both the front and rear parts of the packing to be driven.

In putting together this joint, the loose ring is passed over the ball-spigot and slipped some distance toward the

FIG. 98.

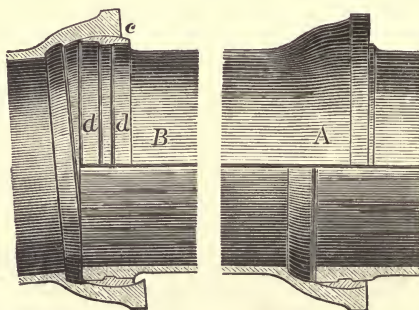

centre of the pipe ; the ball-socket is then entered into the solid part of the bell and its lead joint packing poured and snugly driven ; the loose ring is then bolted in position, and its lead joint packing is poured and firmly driven, also. This secures a solid packing at both front and rear of the

joint, capable of withstanding the strain that comes upon it as the pipe is lowered into position, and ensures a tight joint. The ball-spigot is turned smooth in a lathe to true spherical form.

Fig. 98 illustrates J. B. Ward's patent flexible joint.

460. Thickness Formulas Compared.—The results given by some of the well-known formulas for thicknesses of *cast-iron* pipes, may be compared in Table No. 97.

461. Formulas for Weights of Cast-iron Pipes.—The mean weight of cast-iron is about 450 pounds per cubic foot, or .2604 pounds per cubic inch.

Let d be the diameter of a cast-iron pipe, in inches; t , the thickness of the pipe-shell, in inches; and π the ratio of circumference to diameter ($= 3.1416$); then the cubical volume V_1 , in inches, of a pipe-shell (neglecting the weight of hub), is, for each foot in length,

$$V_1 = (d + t) \times t \times \pi \times 12. \quad (14)$$

When the *length* of a pipe is mentioned, it is commonly the length between the bottom of the hub and the end of the spigot that is referred to; that is, the net length of the pipe laid, or which it will lay.

The *average* weight of a pipe per foot includes the weight of the hub, which, as thus spoken of, is assumed to be distributed along the pipe.

The weights of the hubs, of general form shown in Fig. 96, and whose dimensions are given in Table No. 95 (p. 461), increase the average weight per foot of the twelve-foot light pipes, approximately, eight per cent.; of the medium pipes, seven and one-half per cent.; and of heavier pipes, seven per cent.

The equation for cubical volume of pipe-metal, including hub, is

TABLE No. 97.

FORMULAS FOR THICKNESS OF CAST-IRON PIPES COMPARED.

Assumed static pressure, 75 lbs. per square inch. Assumed tenacity of metal, 18,000 lbs. per square inch.

AUTHORITY.	EQUATIONS.	DIAMETERS.			
		4 in.	12 in.	24 in.	48 in.
		Thick- ness. <i>Inches.</i>	Thick- ness. <i>Inches.</i>	Thick- ness. <i>Inches.</i>	Thick- ness. <i>Inches.</i>
Equation (12), § 452..	$t = \frac{(p+100)d}{.4S} + .333 \left(1 - \frac{d}{100}\right) \dots$.4172	.5850	.8367	1.3400
M. Dupuit	$t = (.0016nd) + .013d + .32 \dots$.4055	.5766	.8333	1.3466
J. F. D'Aubuisson...	$t = (.015d) + .395 \dots$.4550	.5750	.7550	1.1150
Julius Weisbach....	$t = (.00238nd) + .34 \dots$.3899	.4897	.6394	.9389
Dionysius Lardner..	$t = (.007nr) + .38 \dots$.4534	.6002	.8204	1.2608
Thomas Box	$t = \left\{ \frac{\sqrt{d}}{10} + .15 \right\} + \frac{hd}{25000} \dots$.3776	.5794	.8069	1.1750
G. L. Molesworth...	$t = (.000054hd) + \left\{ \begin{array}{l} .37 \text{ for } 4'' \text{ to } 12'' \\ .50 \text{ " } 12 \text{ " } 30 \text{ " } \\ .62 \text{ " } 30 \text{ " } 50 \text{ " } \end{array} \right\}$.4074	.6121	.7242	1.0684
Wm. J. M. Rankine.	$t = \sqrt{\frac{d}{48}} \dots$.2887	.5000	.7071	1.0000
John Neville	$t = [.0016(n+10)d] + .32 \dots$.4175	.6126	.9053	1.4902
Thos. Hawksley ...	$t = .18\sqrt{d} \dots$.3600	.6235	.8818	1.2470
Baldwin Latham ...	$t = \frac{whd}{28.8S} + .25 \dots$.3334	.5002	.7504	1.2508
James B. Francis...	$t = (.000058hd) + .0152d + .312 \dots$.4129	.6148	.9176	1.5232
Thos. J. Whitman...	$t = (.0045nd) + .4 - .0011d \dots$.4900	.6699	.9397	1.4795
M. C. Meigs.....	$t = (.0260416d) + .25 \dots$.3542	.5625	.8750	1.5000
J. H. Shedd	$t = (.00008hd) + .01d + .36 \dots$.4554	.6461	.9322	1.5000
J. F. Ward.....	$t = (.0002hd) + .30 \dots$.4384	.7152	1.1304	1.9608
Jos. P. Davis.....	$t = (.00475nd) + .35 \dots$.4496	.6488	.9476	1.5452

In which t = thickness of pipe wall, in inches.

d = interior diameter of pipe, in inches.

h = head of water, in feet.

w = weight of a cubic foot of water, = 62.5 lbs.

n = number of atmospheres of pressure, at 33 feet each.

p = pressure of water, in pounds per square inch.

S = ultimate tenacity of cast-iron, in pounds per square inch.

$$V = (d + 1.08t) \times t \times \pi \times 12. \quad (15)$$

Let w_1 be the weight per cubic inch of the metal (= .2604 lbs.), and w the *average* weight per foot of the pipe, then we have for equation of average weight per foot, of twelve-foot pipes,

$$w = 12(d + 1.08t) t \pi w_1. \quad (16)$$

To compute the average weight per lineal foot of an 18-inch diameter pipe, twelve feet long, and $\frac{3}{8}$ inch thick in the shell, assign the numerical value to the symbols, and the equation is :

$$\begin{aligned} w &= 12 [18 + (1.08 \times .65625)] \times .65625 \times 3.1416 \times .2604 \\ &= 120.58 \text{ pounds.} \end{aligned}$$

In the equation, 12, π , and w_1 are constants, and may be united, and their product (= 9.81687) supply their place in the equation, when the equation for *average weight per foot* is,

$$w = 9.82(d + 1.08t) \cdot t; \quad (17)$$

and for the *total weight* of a 12-foot pipe :

$$W = 117.8(d + 1.08t) \cdot t. \quad (18)$$

462. Table of Weights of Cast-iron Pipes.—The following table gives minimum weights of three classes of cast-iron pipes, of good, tough, and elastic cast-iron (with $S = 18,000$ lbs.), for heads up to 300 ft. ; also, approximate weights of lead required per joint for the respective diameters, from 4 to 48 inches, inclusive.

TABLE No. 98.

MINIMUM WEIGHTS OF CAST-IRON PIPES.

DIAMETER.	CLASS A. Head, 116 feet. Pressure, 50 lbs.			CLASS B. Head, 230 feet. Pressure, 100 lbs.			CLASS C. Head, 300 feet. Pressure, 130 lbs.			Depth of lead in socket.	Weights of lead per joint.
	Thickness,*	Average weight per lineal foot, $w=9.82 \times (d+1.08d)^2$.	Total weight of a 12-foot pipe.	Thickness.	Average weight per lineal foot, $w=9.82 \times (d+1.075d)^2$.	Total weight of a 12-foot pipe.	Thickness.	Average weight per lineal foot, $w=9.82 \times (d+1.07d)^2$.	Total weight of a 12-foot pipe.		
<i>in.</i>	<i>in.</i>	<i>lbs.</i>	<i>lbs.</i>	<i>in.</i>	<i>lbs.</i>	<i>lbs.</i>	<i>in.</i>	<i>lbs.</i>	<i>lbs.</i>	<i>in.</i>	<i>lbs.</i>
4	.4033	17.57	211	.4311	18.94	227	.4477	19.69	236	1	4.25
6	.4383	27.87	334	.4800	30.71	369	.5050	32.43	389	1	6.25
8	.4734	39.67	476	.5289	44.50	534	.5622	47.49	570	1	8.25
10	.5083	52.66	632	.5777	60.25	723	.6194	64.85	778	1	10.25
12	.5433	67.12	805	.6266	76.20	914	.6766	84.53	1014	2	13.00
14	.5783	83.04	996	.6755	97.68	1172	.7338	106.54	1278	2	15.00
16	.6166	100.90	1211	.7277	119.93	1439	.7944	131.45	1577	2	24.25
18	.6483	119.35	1432	.7733	143.00	1716	.8483	157.51	1890	2	27.25
20	.6833	139.14	1670	.8222	168.61	2023	.9055	186.45	2237	2	30.75
22	.7183	160.64	1928	.8711	196.00	2352	.9628	217.74	2613	2	35.25
24	.7533	183.55	2203	.9200	225.75	2709	1.0200	251.33	3016	2	38.25
27	.8058	220.53	2646	.9933	273.70	3285	1.1058	306.15	3674	2	51.25
30	.8583	260.66	3128	1.0666	326.01	3912	1.1916	366.00	4392	2	56.75
33	.9108	304.00	3648	1.1400	383.13	4598	1.2775	431.15	5174	2	62.25
36	.9633	350.31	4204	1.2183	444.48	5334	1.3633	501.48	6018	2	79.50
40	1.0333	417.20	5006	1.3111	533.15	6398	1.4778	603.45	7241	2	88.75
44	1.1033	489.50	5874	1.4088	629.70	7556	1.5921	714.55	8575	2	107.75
48	1.1733	567.63	6812	1.5066	734.10	8809	1.7066	835.00	10020	2	111.00

The following table gives the weights of pipes that have been used by various water departments for their maximum pressures :

* *Vide* thicknesses of pipes in Table No. 93, p. 455.

TABLE No. 98a.

WEIGHTS OF CAST-IRON PIPES, AS USED IN SEVERAL CITIES FOR THEIR MAXIMUM PRESSURES.

DIAMETER, INCHES.	PHILADELPHIA, NEW YORK, BOSTON, BALTIMORE, BROOKLYN, ST. LOUIS, CHICAGO, PROVIDENCE, LOWELL, FALL RIVER, TOLEDO, ROCHESTER, OTTAWA, RICHMOND, MILWAUKEE.																DIAMETER, INCHES.
	Maximum Head, in feet.																
	R.	R.	R.	R.	R.	R.	S.-P.	R.	R.	S.-P.	S.-P.	R. & D.-P.	D.-P.	R.	R. & S.-P.		
	250	100	180	218	198	170	125	180	200	260	175	200	250	237	200		
Average Weights, per lineal foot, in pounds.																	
3	15	...	13½	12	14	14	...	3	
4	19	24	20	18½	18	...	24½	24	23½	20	*25	20	...	4	
6	31	36	32	28½	39½	35	36½	33½	34	43	34	32	...	30	35	6	
8	42	...	46	40	55	...	50	49	49	69	48	45	46	45	50	8	
10	53	56	64½	...	87	...	53½	...	60	...	10	
12	71	86	81	85	90	85	83½	85	85	123	85	75	86	100	87	12	
14	103	*125	14	
16	105	...	124	130	125	128	129½	197½	134	113	...	130	129½	16	
20	151	170	174	200	208	183	...	178½	182	239	194	165	...	170	194	20	
24	307	235	231	250	239	241½	257	265	265	202	230	266½	24	
30	330	340	337	350	407½	325	...	338	350	...	358	334	257	330	351	30	
36	422	405	458	...	400	438	450	472	412	36	
48	585	690	606	...	692	48	

The initials in the horizontal column of heads indicate the systems of pressure, viz., R., reservoir; S.-P., stand-pipe; and D.-P., direct pressure.

463. Interchangeable Joints.—When several classes of pipes, varying in weight for similar diameters, enter into the same system of distribution, as, for instance, in an undulating town, with considerable differences in levels, there is an advantage in making the exterior diameters the constants, instead of the interiors, for then the spigots and bells of both plain and special castings, and of valves and hydrants, have uniformity, and are interchangeable, as occasion requires, and the different classes join each other without special fittings.

* The Ottawa pipe weights classed as of 4 and 14 inch diameters are in fact 5 and 15 inch diameters respectively.

If it is objectionable to increase and decrease the interior diameters of the light and heavy classes, then the object may be attained by increasing the thickness of the ends of the light and medium classes, so far as they enter the hubs.

464. Characteristics of Pipe-Metals.—The metal of pipes should be tough and elastic, and have great tenacity. In proportion as these qualities are lacking, bulk of metal, increased in a geometrical ratio, must be substituted to produce their equivalents. In our formula given above (§ 452) for thickness of cast-iron, it will be remembered that we were obliged to add a term of thickness

$\left\{.333\left(1 - \frac{d}{100}\right)\right\}$ to enable the pipes to be safely handled.

If the metal is given great degrees of toughness and elasticity, we may omit, for the larger pipes, this last member of the formula; but now we add to each twelve-foot piece of pipe, of 20-inch diameter, five or six hundred pounds; 36-inch diameter, six or eight hundred pounds, etc., that would not be required with a superior metal.

It is expensive to freight this extra metal a hundred or more miles, and then to haul it to the trenches and swing it into place, and at the same time to submit to the breakage of from three to five per cent. of the castings because of the brittleness of the inferior metal.

It is well known that the same qualities of iron stone, and of fuel, may produce from the same furnace very different qualities of pigs, and it is the smelter's business to know, and he generally does know, whether he has so proportioned his materials and controlled his blast, as to produce pigs that when remelted will flow freely into the mould, take sharply its form, and become tough and elastic castings. The founders will supply a refined and homogeneous iron, if such quality is clearly specified, and it is well worthy of

consideration in the majority of cases whether such iron will not be in fact the most economical, at its fair additional cost, if extra weight, extra freight and haulage, and extra breakage, are duly considered.

Expert inspectors cannot with confidence pronounce upon the quality of the cast metal from an examination of its exterior appearance, nor infallibly from the appearance of its fracture. Wilkie says* of the fracture of good No. 1 cast-iron, that it shows a dark gray color with high metallic lustre; the crystals are large, many of them shining like particles of freshly-cut lead; and that however thin the metal may be cast, it retains its dark gray color. It contains from three to five per cent. of carbon. This is the most fusible pig iron and most fluid when melted, and superior castings may be produced from it.

No. 3 has smaller and closer crystals, which diminish in size and brightness from the centre of the casting toward the edge. Its color is a lighter gray than No. 1, with less lustre. No. 2 is intermediate in appearance and quality between Nos. 1 and 3.

The "*bright*," "*mottled*," and "*white*" irons have still lighter colored fractures, with a white "*list*" at the edges, are less fusible, and are more crude, hard, and brittle.

The mottled and white irons are sometimes produced by the furnace working badly, or result from using a minimum of fuel with the ore and flux.

The crystals of the coarser kinds of cast-irons were found by Dr. Schott, in his microscopical examinations of fractures, to be nearly cubical, and to become flatter as the proportion of carbon decreased and the grain became more uniform.

* "The manufacture of Iron in Great Britain." London, 1857.

In wrought iron, the double pyramidal form of the cast crystal is almost lost, and has become flattened down to parallel leaves, forming what is termed the fibre of the iron.

In steel the crystals have become quite parallel and fibrous.

465. Tests of Pipe Metals.—The toughness and elasticity of pipe metal may be tested by taking sample *rings* of, say, 24-inch diameter, 1-inch width, and $\frac{3}{4}$ -inch thickness, hanging them upon a blunt knife-edge, and then suspending weights from them, at a point opposite to their support, noting their deflections down to the breaking point; also, by letting similar rings fall from known heights upon solid anvils. The iron may also be submitted to what is termed the “beam test,” generally adopted to measure the transverse strength and elasticity of castings for building purposes.

In such case the standard bar, Fig. 99, is 3 ft. 6 in. long, 2 in. deep, and 1 in. broad, and is placed on bearings 3 ft. apart, and is loaded in the middle till broken.

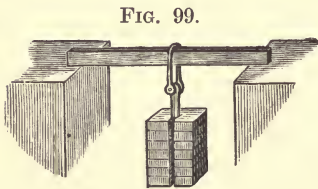

Iron that has been first skillfully made into pigs, from good ore and with good fuel, and has

then been remelted, should sustain in the above described beam test, from 4,000 to 4,500 pounds, and submit to a deflection of from $\frac{4}{10}$ to $\frac{1}{2}$ -inch.

The tenacity of the iron is usually measured by submitting it to direct tensile strain in a testing machine, fitted for the purpose. Its tenacity should reach an ultimate limit of 25,000 pounds per square inch of breaking section, while still remaining tough and elastic. Hard and brittle irons may show a much greater tenacity, though making less valuable pipes.

466. The Preservation of Pipe Surfaces.—The uncoated iron mains first laid down in London, by the New River Company, were supposed to impart a chalybeate quality to the water, and a wash of lime-water was applied to the interiors of the pipes before laying to remedy this evil.

Before iron pipes had been long in use, in the early part of the present century, in those European towns and cities supplied with soft water, it was discovered that tuberculous accretions had formed so freely upon their interiors as to seriously diminish the volume of flow through the pipes of three, four, and six-inch diameters.

This difficulty, which was so serious as to necessitate the laying of larger distribution pipes than would otherwise have been necessary, engaged the attention of British and continental engineers and chemists from time to time. Many experimental coatings were applied, of silicates and oxides, and the pipes were subjected to baths of hot oil under pressure, with the hope of fully remedying the difficulty. A committee of the British Association also inquired into the matter in connection with the subject of the preservation of iron ships, and instituted valuable experiments, which are described in two reports of Robert Mallet to the Association.

A similar difficulty was experienced with the uncoated iron pipes first laid in Philadelphia and New York.

In the report of the city engineer of Boston, January, 1852, mention is made of some pipes taken up at the South Boston drawbridge, which had been exposed to the flow of Cochituate water nine years.

He remarks that “some of the pipes were covered internally with tubercles which measured about two inches in area on their surfaces, by about three-quarters of an inch in height, while others had scarcely a lump raised in them.

Those which were covered with the tubercles were corroded to a depth of about one-sixteenth of an inch; the iron to that depth cutting with the knife very much like plumbago." Mr. Slade, the engineer, expressed the opinion, after comparing the condition of these pipes with that of pipes examined in 1852, that the corrosion is very energetic at first, but that it gradually decreases in energy year by year.

The process used by Mons. Le Beuffe, civil engineer of Vesoul, France, for the defence of pipes, as communicated* by him to Mr. Kirkwood, chief engineer of the Brooklyn Water-works, "consists of a mixture of linseed oil and beeswax, applied at a high temperature, the pipe being heated and dipped into the hot mixture.

The varnish of M. Crouzière, tested on iron immersed in sea-water at Toulon, by the French navy, consisted of a mixture of sulphur, rosin, tar, gutta-percha, minum, blanch de ceruse, and turpentine. This protected a plate of wrought iron perfectly during the year it was immersed.

A process that has proved very successful for the preservation of iron pipes used to convey acidulated waters from German mines, is as follows:† "The pipes to be coated are first exposed for three hours in a bath of diluted sulphuric or hydrochloric acid, and afterward brushed with water; they then receive an under-coating composed of 34 parts of silica, 15 of borax, and 2 of soda, and are exposed for ten minutes in a retort to a dull red heat. After that the upper coating, consisting of a mixture of 34 parts of feldspar, 19 of silica, 24 of borax, 16 of oxide of tin, 4 of fluorspar, 9 of soda, and 3 of saltpetre, is laid over the interior surface, and the pipes are exposed to a white heat for twenty minutes in a retort, when the enamel perfectly unites

* *Vide* Descriptive Memoir of the Brooklyn Water-works, p. 43. N. Y., 1867.

† *Vide* "Engineering." London, Jan., 1872, p. 45.

with the cast-iron. Before the pipes are quite cooled down, their outside is painted with coal-tar. The above ingredients of the upper coating are melted to a mass in a crucible, and afterwards with little water ground to a fine paste."

Prof. Barff, M.A., proposes to preserve iron (including iron water-pipes) by converting its surfaces into the magnetic or black oxide of iron, which undergoes no change whatever in the presence of moisture and atmospheric oxygen.

He says, "The method which long experience has taught us is the best for carrying out this process for the protection of iron articles, of common use, is to raise the temperature of those articles, in a suitable chamber, say to 500° F., and then pass steam from a suitable generator into this chamber, keeping these articles for five; six, or seven hours, as the case may be, at that temperature in an atmosphere of superheated steam.

"At a temperature of 1200° F., and under an exposure to superheated steam for six or seven hours, the iron surface becomes so changed that it will stand the action of water for any length of time, even if that water be impregnated with the acid fumes of the laboratory."

The first coated pipes used in the United States, were imported from a Glasgow foundry in 1858. These were coated by Dr. Angus Smith's patent process, which had been introduced in England about eight years earlier. Dr. Smith's Coal Pitch Varnish is distilled from coal-tar until the naphtha is entirely removed and the material deodorized, and Dr. Smith recommends the addition of five or six per cent. of linseed oil.

The pitch is carefully heated in a tank that is suitable to receive the pipes to be coated, to a temperature of about

300 degrees, when the pipes are immersed in it and allowed to remain until they attain a temperature of 300° Fah.

A more satisfactory treatment is to heat the pipes in a retort or oven to a temperature of about 310° Fah., and then immerse them in the bath of pitch, which is maintained at a temperature of not less than 210°.

When linseed oil is mixed with the pitch, it has a tendency at high temperature to separate and float upon the pitch. An oil derived by distillation from coal-tar is more frequently substituted for the linseed oil, in practice.

The pipes should be free from rust and strictly clean when they are immersed in the pitch-bath.

467. Varnishes for Pipes and Iron-work.—A good *tar varnish*, for covering the exteriors of pipes where they are exposed, as in pump and gate houses, and for exposed iron work generally, is mentioned * by Ewing Matheson, and is composed as follows: 30 gallons of coal-tar fresh, with all its naphtha retained; 6 lbs. tallow; 1½ lbs. resin; 3 lbs. lampblack; 30 lbs. fresh slacked lime, finely sifted. These ingredients are to be intimately mixed and applied hot. This varnish may be covered with the ordinary linseed-oil paints as occasion requires.

A *black varnish*, that has been recommended for outdoor iron work, is composed as follows: 20 lbs. tar-oil; 5 lbs. asphaltum; 5 lbs. powdered rosin. These are to be mixed hot in an iron kettle, with care to prevent ignition. The varnish may be applied cold.

468. Hydraulic Proof of Pipes.—When the cast-iron pipes have received their preservative coating, they should be placed in an hydraulic proving-press, and tested by water pressure, to 300 lbs. per sq. in.; and while under

the pressure be smartly rung with a hammer, to test them for minor defects in casting, and for undue internal strains.

Fig. 100 is one of the most simple forms of hydraulic proving-presses. The cast-iron head upon the left is fixed stationary, while toward the right is a strong head that is movable, and that advances and retreats by the action of

Fig. 100.

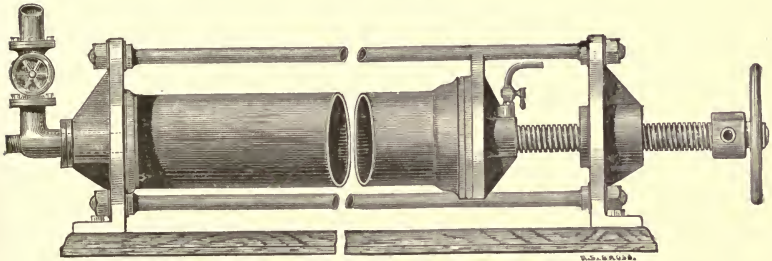

the screw working in the nut of the fixed head at the right. When the pipe is rolled into position for a test, suitable gaskets are placed upon its ends, or against the two heads, and then by a few turns of the hand-wheel of the screw, the movable head is set up so as to press the pipe between the two heads. Levers are then applied to the screw, and the pressure increased till there will be no leakage of water at the ends past the gaskets. The air-cock at the right is then opened to permit escape of the air, and the water-valve at the left opened to fill the pipe with water. The hydraulic pump and the water-pressure gauge, which are attached at the left, are not shown in the engraving. When the pipe is filled with water, and the valves closed, the requisite pressure is then applied by means of the pump. Care must be taken that all the air is expelled, before pressure is applied, lest in case of a split, the compressed air may scatter the pieces of iron with disastrous results.

FIG. 101.

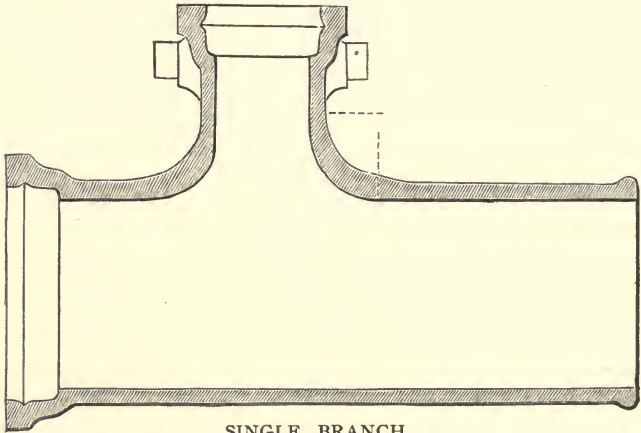

SINGLE BRANCH.

FIG. 102.

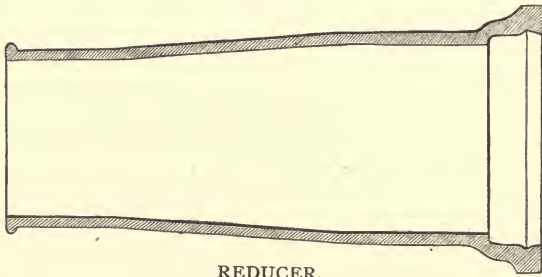

REDUCER.

FIG. 103.

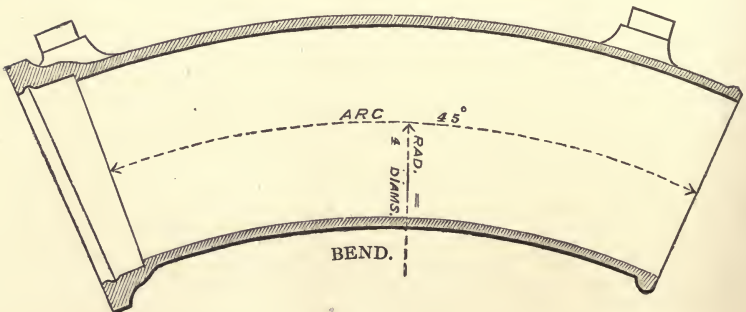

BEND.

469. Special Pipes.—Fig. 101 is a section through a single Branch, with side views of lugs for securing a cap or hydrant branch.

Fig. 102 is a section through a Reducer.

Fig. 103 is a section through a Bend.

FIG. 104.

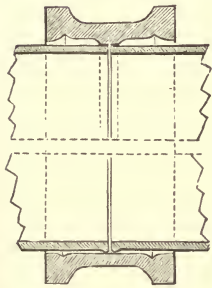

FIG. 105.

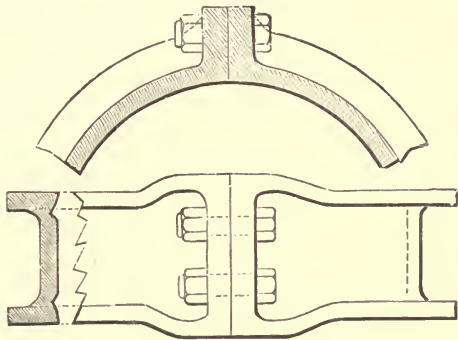

Fig. 104 is a section through a Sleeve, the upper half being the form for covering cut ends of pipes, and the lower half the form for uncut spigot ends.

Fig. 105 is a part section and plan of a clamp Sleeve.

WROUGHT-IRON PIPES

470. Cement-Lined and Coated Pipes.—Sheet-iron water-pipes, lined and coated with hydraulic cement mortar, by a process invented by Jonathan Ball, were laid in Saratoga, N. Y., to conduct a supply of water for domestic purposes to some of the citizens, as early as 1845.

The inventor, who was aware of the ready corrosion of wrought-iron when exposed to a flow of water and to the dampness and acids of the earth, had observed the preservative influence of lime and cement when applied to iron, and saw that with its aid, the high tensile strength of

wrought or rolled iron, could be utilized in water-pipes to sustain considerable pressures of water, and the weight of the iron required, thus be materially reduced.

The reduction in the weight of the iron reduced also the total cost of the complete pipe in the trench.

The favorable qualities of hydraulic cement as a conductor of potable waters had long been well-known, for the Romans invariably lined their aqueducts and conduits with it.

Twenty-five or thirty towns and villages, and a number of corporate water companies had already adopted the wrought-iron cement-lined water pipes in their systems, and still others were experimenting with it at the breaking out of the civil war in 1861.

As one result of the war, the price of iron * rose to more than double its former value, and the difference in cost between cast and wrought iron pipes became conspicuous, and the cost of all pipes rose to so great total sums that the pipe of least first cost must of necessity be adopted in most instances, almost regardless of comparative merits. So long as the high prices of iron and of labor remained firm, the contractors for the wrought-iron were enabled to lay it at a reduction of forty per cent. from the cost of the cast-iron pipe.

Increased attention to sanitary improvements led many towns to complete their water supplies even at the high rates, and many hundred miles of the cement-lined pipes came into use.

471. Methods of Lining.—Its manufacture is simple. The sheet-iron is formed and closely riveted into cylinders

* New York and Philadelphia prices current record the nearly regular average monthly increase in the price of Anthracite Pig Iron No. 1, from 18 $\frac{1}{2}$ dollars per ton of 2240 pounds in August, 1861, to 73 $\frac{3}{4}$ dollars per ton in August, 1864.

of seven or eight feet in length, and of diameter from one to one and one-half inches greater than the clear bore of the lining is to be finished. The pipe is then set upright and a short cylinder, of diameter equal to the desired bore of the pipe, is lowered to the bottom of the pipe. Some freshly mixed hydraulic cement mortar is then thrown into the pipe and the cylinder, which has a cone-shaped front; and guiding spurs to maintain its central position in the shell, is drawn up through the mortar. A uniform lining of the mortar is thus compressed within the wrought-iron shell. The ends are then dressed up with mortar by the aid of a small trowel or spatula, and the pipes carefully placed upon skids to remain until the cement is set.

The interiors of the pipe-linings are treated to a wash of liquid cement while they are still fresh, so as to fill their pores.

In another process of lining, a smoothly-turned cylindrical mandril of iron, equal in length to the full length of the pipe, and in diameter to the diameter of the finished bore, is used to form the bore, and to compress the lining within the shell. A fortnight or three weeks is required for the cement to set so as safely to bear transportation or haulage to the trenches. In the meantime the iron is or should be protected from storms and moisture, and also from the direct rays of the sun, which unduly expands the iron, and separates it from a portion of the cement lining.

472. Covering.—When these pipes are laid in the trench, a bed of cement mortar is prepared to receive them, and they are entirely coated with about one inch thickness of cement mortar, as is shown in the vertical section of a six-inch pipe, Fig. 106.

The writer has used upwards of one hundred miles of this kind of pipes, and the smaller sizes have proved uniformly successful.

FIG. 106.

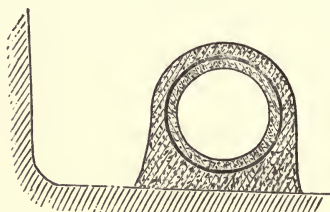

The iron is relied upon wholly to sustain the pressure of the water and resist the effects of water-rams. The cement is depended upon to preserve the iron, which object it has accomplished during the term these pipes have been in use, when the cement was good and workmanship faithful, which, unfortunately for this class of pipe, has not always been the case, and the reputation of the pipe has suffered in consequence.

FIG. 107.

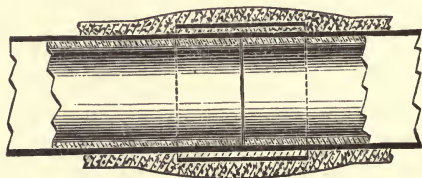

473. Cement-Joint.—A sheet-iron sleeve, about eight inches long, as shown in Fig. 107, is used in the common form of joint to cover the abutting ends of the pipe as they are laid in the trench.

The diameter of the sleeve is about one inch greater than the diameter of the wrought-iron pipe shell, and the annular space between the pipe and sleeve is filled with cement. The sleeve and pipe are then covered with cement mortar.

In a more recently patented form of pipe, the shell has a taper of about one inch in a seven-foot piece of pipe, and

the small end of one piece of pipe enters about four inches into the large end of the adjoining pipe, thus forming a lap without a special sleeve. The thickness of lining in these pipes varies, but the bore is made uniform.

474. Cast Hub-Joints.—The writer having experienced some difficulty with both the above forms of cement-joints, of the larger diameters, and desiring to substitute lead packings for the cement, in a 20-inch force main, to be subjected to great strains, devised the form of joint shown in Fig. 108.

FIG. 108.

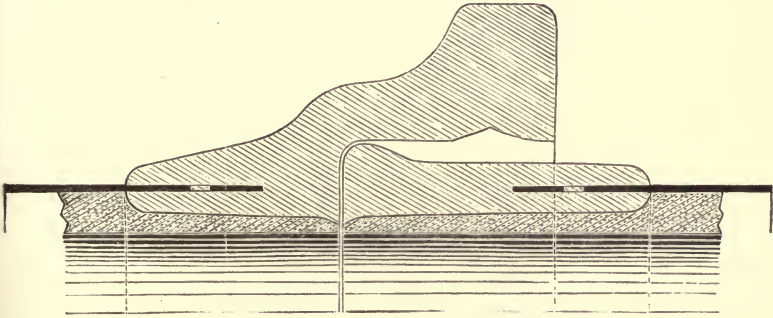

In this case the wrought-iron shells were riveted up as for the common 20-inch pipe, and then the pipe was set upon end in a foundry near at hand, a form of bell moulded about one end, and molten iron poured in, completing the bell in the usual form of cast-iron bell. A spigot is cast upon the opposite end in a similar manner. The lead packing is then poured and driven up with a set, as the pipes are laid, as is usual with cast-iron pipes. The joint is as successful in every respect as are the lead-joints of cast-iron pipes.

The force-main in question has been in use upwards of three years, and water was, during several months of its

earliest use, pumped through it into the distribution pipes, on the direct pumping system.

For lead joints on wrought-iron pipes from ten to sixteen inches diameter inclusive, about four inches width of the edge of the spigot end sheet may be rolled thicker, so as to bear the strain of caulking the lead, as a substitute for the cast spigot.

475. Composite Branches. — The wrought-iron branches were originally joined to their mains by the application of solder, the iron being first tinned near and at the junction. After the successful pouring of the bells, the experiment was tried of uniting the parts by pouring molten metal into a mould, formed about them, the metal being

FIG. 109.

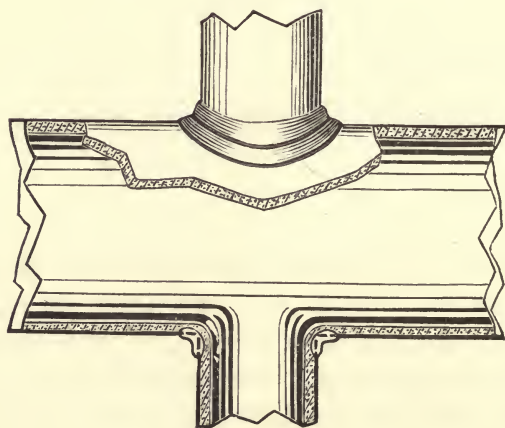

cast partly outside and partly inside the pipes, as in the case of the hub-joint. The parts were rigidly and very substantially united by the process, which is in practical effect equal to a weld.

Fig. 109 shows a section of a double six-inch branch on a twelve-inch sub-main.

Fig. 110 is a section of a wrought-iron angle with its parts united by a cast union.

Several holes, similar to the rivet holes of the pipe, are punched near the ends to be united at different points in the circumference, so that the metal flows through them, as shown in the sketches.

FIG. 110.

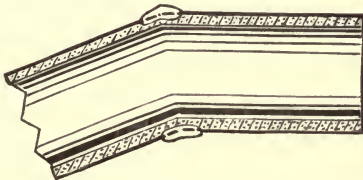

The writer has used these branches and angles exclusively in several cities, in wrought-iron portions of the distribution-pipes, without a single failure.

476. Thickness of Shells for Cement Linings.—

When computing the thickness of sheets for the shells of wrought-iron cement-lined pipes, the internal diameter of the shell itself, and not of finished *bore*, is to be taken. The longitudinal joints of the shells for pipes of 12-inch and greater diameters, should be closely double riveted.

The tensile strength of the shells, when made of the best plates, may be assumed, if single riveted, 36,000 pounds per square inch, and double riveted 40,000 pounds per square inch.

A formula of thickness, given above, with factor of safety = 4, in addition to allowance for water-ram, may be used to compute the thickness of plates, viz.:

$$t = \frac{(p + 100)d}{.5S}, \quad (19)$$

in which t is the thickness of rolled plate, in inches.

d “ diameter of the shell, in inches.

p “ static pressure due to the head in lbs. per sq. in. = $.434 h$.

S “ tenacity of riveted shells, in lbs. per. sq. in.

The following table gives the thickness of shells for cement linings, and the nearest No. of Birmingham gauge in excess, suitable for heads of from 100 to 300 feet, by formula,

$$t = \frac{(p + 100)d}{.5S}.$$

TABLE No. 99.

THICKNESS OF WROUGHT IRON PIPE SHELLS.

(Diameters 4" to 10" single riveted, $S = 36,000$ lbs. Diameters 12" and upward, double riveted, $S = 40,000$ lbs.)

DIAMETER OF BORE.	DIAMETER OF SHELL.	HEAD 116 FEET.		HEAD 175 FEET.		HEAD 300 FEET.	
		Thickness by Formula.	Nearest No. Birm. Gauge in Excess.	Thickness by Formula.	Nearest No. Birm. Gauge in Excess.	Thickness by Formula.	Nearest No. Birm. Gauge in Excess.
<i>Inches.</i>	<i>Inches.</i>	<i>Inches.</i>		<i>Inches.</i>		<i>Inches.</i>	
4	5	.0417	19	.0486	18	.0639	16
6	7	.0528	17	.0681	15	.0894	13
8	9.25	.0771	15	.0899	13	.1182	11
10	11.25	.0937	13	.1094	12	.1437	9
12	13.25	.0994	12	.1159	11	.1524	8
14	15.25	.1144	12	.1334	10	.1754	7
16	17.5	.1313	10	.1532	8	.2012	6
18	19.5	.1463	9	.1706	7	.2242	5
20	21.5	.1613	8	.1881	6	.2472	3
22	23.5	.1763	7	.2056	5	.2702	2
24	25.5	.1913	6	.2236	4	.2932	1

Shells having less factors of safety than our formula gives, have been used in many small works. A factor equal to 6, to include effect of water-ram, should always be

taken, and this may be found directly by a formula in the following form :

$$t = \frac{pd}{3333S} \quad (20)$$

477. Gauge Thickness and Weights of Rolled Iron.—The following table (No. 100) gives the thicknesses and weights of sheet-iron, corresponding to Birmingham gauge numbers ; also thicknesses and weights increasing by sixteenths of an inch.

478. Lining, Covering, and Joint Mortar.—The lining mortar and covering mortar should have the volume of cement somewhat in excess of the volume of voids in the sand, or, for linings, equal parts of the best hydraulic cement and fine-grained, sharp, silicious sand ; and, for coverings, two-fifths like cement and three-fifths like sand.

The joint mortar should be of clear cement, or may be of four parts of good Portland cement, and one part of hydraulic lime, with just enough water to reduce it to a stiff paste.

This kind of pipe demands very good materials for all its parts, and the most thorough and faithful workmanship.

A concrete foundation should be laid for it in quicksand, or on a soft bottom, and a bed of gravel, well rammed, should be laid for it in rock trench, and exceeding care must be taken in replacing the trench back-fillings. Poor materials or slighted workmanship will surely lead to after annoyance.

Some of the cement-lined pipes are given a bath in hot asphaltum before their linings are applied. In such case, a sprinkling of clean, sharp sand over their surfaces immediately after the bath, while the coating is tacky, assists in forming bond between the cement and asphaltum.

TABLE No. 100.

THICKNESSES AND WEIGHTS OF PLATE-IRON.

Birmingham gauge No.	Thickness.	Weight of a square foot.	Thickness, in sixteenths of an inch.	Thickness, in decimals of an inch.	Weight of a square foot.
	<i>Inches.</i>	<i>Pounds.</i>	<i>Inches.</i>	<i>Inches.</i>	<i>Pounds.</i>
0000	.454	18.35	$\frac{7}{32}$.03125	1.263
000	.425	17.18	$\frac{1}{16}$.06250	2.526
00	.38	15.36	$\frac{3}{32}$.09375	3.789
0	.34	13.74	$\frac{1}{8}$.12500	5.052
1	.3	12.13	$\frac{5}{32}$.15625	6.315
2	.284	11.48	$\frac{3}{16}$.18750	7.578
3	.259	10.47	$\frac{7}{32}$.21875	8.841
4	.238	9.619	$\frac{1}{4}$.25000	10.10
5	.22	8.892	$\frac{9}{32}$.28125	11.37
6	.203	8.205	$\frac{5}{16}$.31250	12.63
7	.18	7.275	$\frac{11}{32}$.34375	13.89
8	.165	6.669	$\frac{3}{8}$.37500	15.16
9	.148	5.981	$\frac{13}{32}$.40625	16.42
10	.134	5.416	$\frac{7}{16}$.43750	17.68
11	.12	4.850	$\frac{15}{32}$.46875	18.95
12	.109	4.405	$\frac{1}{2}$.50000	20.21
13	.095	3.840	$\frac{9}{16}$.56250	22.73
14	.083	3.355	$\frac{5}{8}$.62500	25.26
15	.072	2.910	$\frac{11}{16}$.68750	27.79
16	.065	2.627	$\frac{3}{4}$.75000	30.31
17	.058	2.344	$\frac{13}{16}$.81250	32.84
18	.049	1.980	$\frac{7}{8}$.87500	35.37
19	.042	1.697	$\frac{15}{16}$.93750	37.89
20	.035	1.415	1	1	40.42
21	.032	1.293	$1\frac{1}{16}$	1.06250	42.94
22	.028	1.132	$1\frac{1}{8}$	1.12500	45.47
23	.025	1.010	$1\frac{3}{16}$	1.18750	48.00
24	.022	.8892	$1\frac{1}{4}$	1.25000	50.52
25	.02	.8083	$1\frac{5}{16}$	1.31250	53.05
26	.018	.7225	$1\frac{3}{8}$	1.37500	55.57
27	.016	.6467	$1\frac{7}{16}$	1.43750	58.10
28	.014	.5658	$1\frac{1}{2}$	1.50000	60.63
29	.013	.5254	$1\frac{9}{16}$	1.56250	63.15
30	.012	.4850	$1\frac{5}{8}$	1.62500	65.68
31	.010	.4042	$1\frac{11}{16}$	1.68750	68.20
32	.009	.3638	$1\frac{3}{4}$	1.75000	70.73
33	.008	.3233	$1\frac{13}{16}$	1.81250	73.26
34	.007	.2829	$1\frac{7}{8}$	1.87500	75.78
35	.005	.2021	$1\frac{15}{16}$	1.93750	78.31
36	.004	.1617	2	2	80.83

479. Asphaltum-coated Wrought-iron Pipes.—

Wrought-iron pipes, coated with asphaltum, have been used almost exclusively in California, Nevada, and Oregon, some of those of the San Francisco water supply being thirty inches in diameter.

Some of these wrought-iron pipes, in siphons, are subjected to great pressure, as, for instance, in the Virginia City, Nevada, supply main, leading water from Marlette Lake.

This main is $11\frac{1}{2}$ inches diameter, and 37,100 feet in length, and crosses a deep valley between the lake, upon one mountain and Virginia City upon another. The inlet, where the pipe receives the water of the lake, is 2,098 feet above the lowest depression of the pipe in the valley, where it passes under the Virginia and Truckee Railroad, and the delivery end is 1528 feet above the same depression. A portion of the pipe is subjected to a steady static strain of 750 pounds per square inch.

The thickness of this pipe-shell varies, according to the pressure upon it, as follows :

Head, in feet.....	}	200	200	330	430	570	700	950	1050	1250	1400
		or	to	to	to	to	to	to	to	to	and
		less.	330	430	570	700	950	1050	1250	1400	over.
No. of iron, Birmingham gauge...		16	15	14	12	11	9	7	5	3	0
Thickness, in inches065	.072	.083	.109	.12	.148	.18	.22	.259	.34

The joints are covered with a sleeve, and the joint packing is of lead.

480. Asphaltum-Bath for Pipes.—A description of the asphaltum coating, as prepared for these pipes by Herman Schussler, C.E., under whose direction many pipes have been laid, is given in the January, 1874, Report of J. Nelson Tubbs, Esq., Chief Engineer of the Rochester Water-works, as follows, in Mr. Schussler's language :

“The purest quality of asphaltum (we use the Santa Barbara) is selected and broken into pieces of from the size of a hen’s egg to that of a fist. With this, three or four round kettles are filled full, then the interstices are filled with the best quality of coal tar (free from oily substances), and boiled from three to four hours, until the entire kettle charge is one semi-fluid mass, it being frequently stirred up. The best and most practical test then, as to the suitability of the mixture, is to take a piece of sheet-iron of the thickness the pipe is made of, say six inches square, it being cold and freed from impurities, and dip it into the boiling mass, and keep it there from five to seven minutes. Immediately after taking it out, plunge it into cold water, if possible near the freezing-point, and if, after removal from the water, the coating don’t become brittle, so as to jump off the iron in chips, by knocking it with a hammer, but firmly adheres (like the tin coating to galvanized iron), the coat is good and will last for ages. If, on the other hand, it is brittle, it shows that there is either too much oil in the tar or asphaltum, or the mixture was boiled too hot, or there was too much coal-tar in the mixture; as adding coal-tar makes the mixture brittle, while by adding asphaltum it becomes tough and pliable. The pipes are immersed in the bath as thus prepared.”

Wrought-iron pipes of this description are extensively used in France, in diameters up to 48 inches.

They are first subjected to a bath of hot asphaltum, and then the exteriors are coated with an asphaltum concrete, into which some sand is introduced, as into the cement-covering above described.

481. Wrought Pipe Plates.—The shells of wrought-iron conduits and pipes should be of the best rolled plates, of tough and ductile quality, of ultimate strength not less

than 55,000 lbs. per square inch, and that will elongate fifteen per cent. and reduce in sectional area twenty-five per cent. before fracture.

WOOD PIPES.

482. Bored Pipes.—The wooden pipes used to replace the leaden pipes, in London, that were destroyed by the great fire, three-quarters of a century ago, reached a total length exceeding four hundred miles. These pipes were bored with a peculiar core-auger, that cut them out in nests, so that small pipes were made from cores of larger pipes.

The earliest water-mains laid in America were chiefly of bored logs, and recent excavations in the older towns and cities have often uncovered the old cedar, pitch-pine, or chestnut pipe-logs that had many years before been laid by a single, or a few associated citizens, for a neighborhood supply of water.

Bored pine logs, with conical faucet and spigot ends, and with faucet ends strengthened by wrought-iron bands, were laid in Philadelphia as early as 1797.

Detroit had at one time one hundred and thirty miles of small wood water-pipes in her streets.

483. Wyckoff's Patent Pipe.—A patent wood pipe, manufactured at Bay City, Michigan, has recently been laid in several western towns and cities, and has developed an unusual strength for wood pipes. Its chief peculiarities are, a spiral banding of hoop-iron, to increase its resistance to pressure and water-ram; a coating of asphaltum, to preserve the exterior of the shell; and a special form of thimble-joint.

Fig. 111 is a longitudinal section through a joint of this wood pipe, showing the manner of inserting the thimble,

FIG. 111.

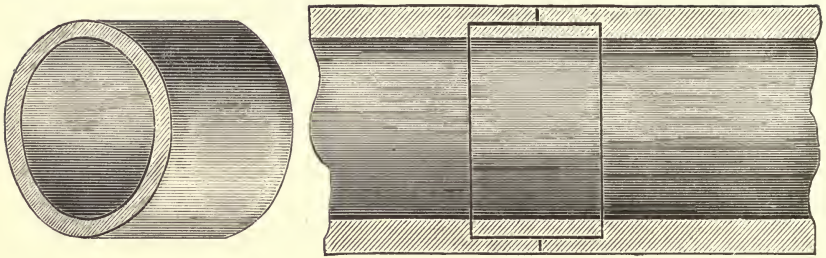

and Fig. 112 is an exterior view of the pipe, showing the spiral banding of hoop-iron, and the asphaltum covering.

The manufacturer's circular, from which the illustrations are copied, states that the pipes made under this

FIG. 112.

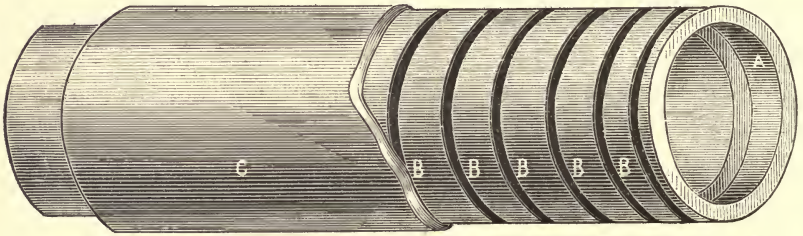

patent are from white pine logs, in sections eight feet long. The size of the pipes is limited only by the size of the suitable logs procurable for their manufacture.

Judged by schedules of factory prices, these pipes do not appear to be cheaper in first cost than wrought-iron pipes.

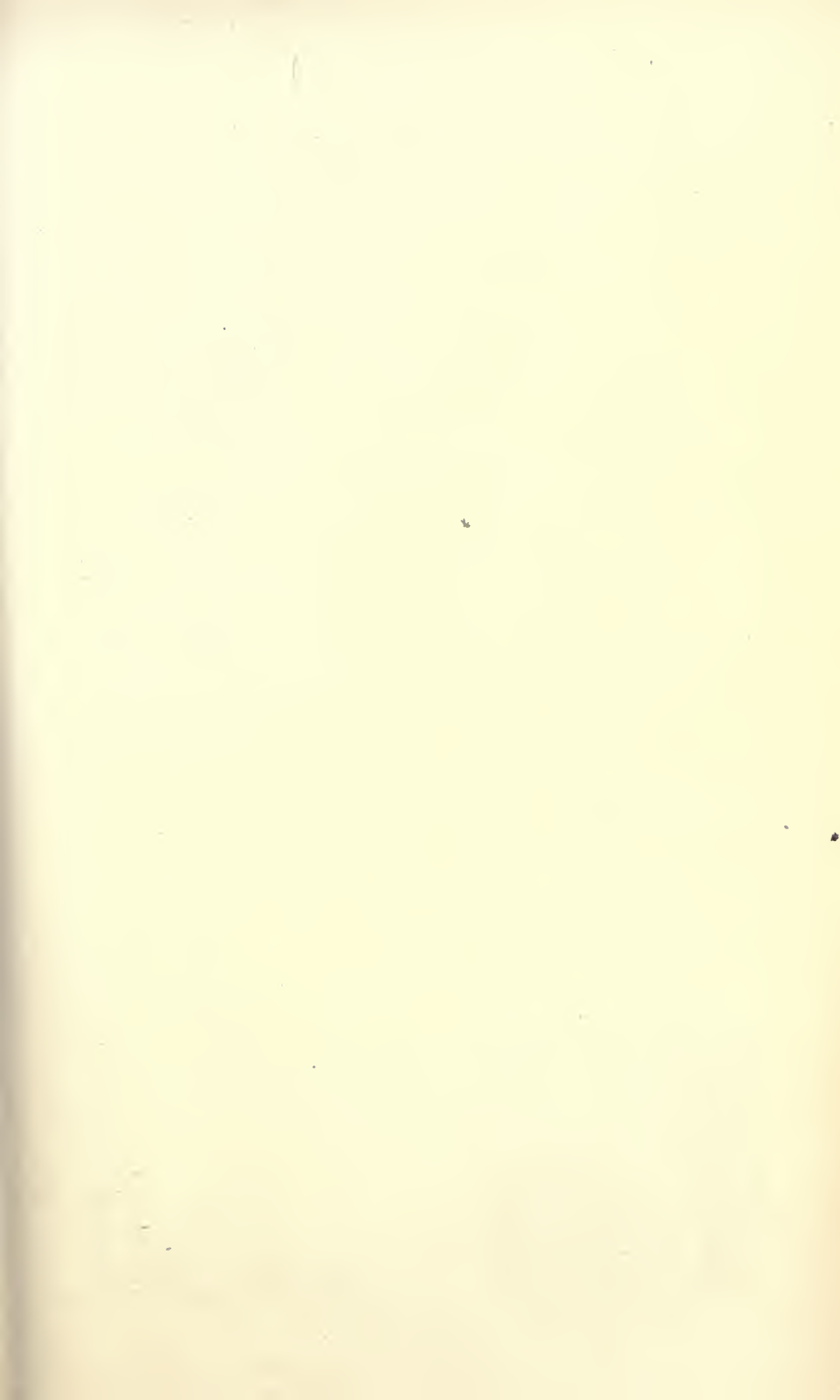

FIGS. 114, 115.

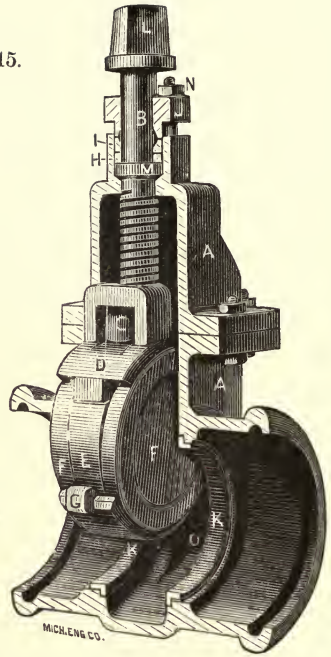
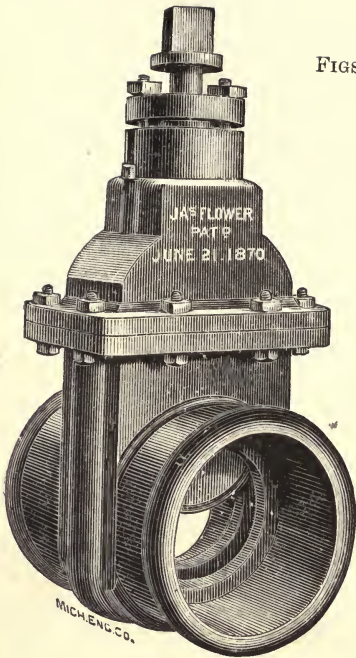

FLOWERS STOP-VALVE.—(Flowers Brothers, Detroit.)

FIGS. 116, 117.

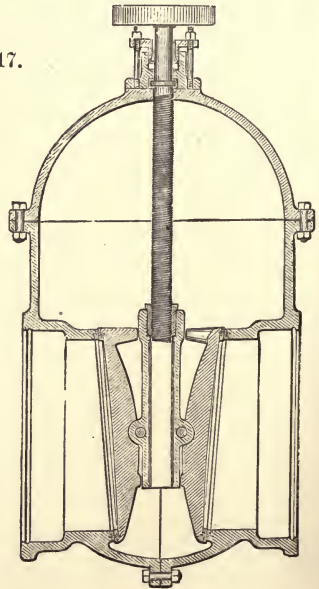
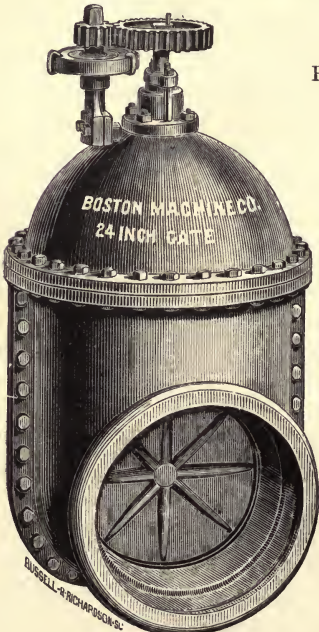

COFFIN'S STOP-VALVE.—(Boston Machine Co., Boston.)

CHAPTER XXII.

DISTRIBUTION SYSTEMS, AND APPENDAGES.

484. Loss of Head by Friction.—In the chapter upon *flow of water in pipes* (XIII, *ante*), we have discussed at length the question of the maximum discharging capacities of pipes. When planning a system of distribution pipes for a domestic and fire service, it is quite as important to know how much of the available head will be consumed by, or will remain after, the passage of a given quantity of water through a given pipe.

For a really valuable fire service, the *effective* head pressure remaining upon the pipes, *with full draught*, should be, in commercial and manufacturing sections of a town, not less than *one hundred and fifty feet*, and in suburban sections, not less than *one hundred feet*.

Water at such elevations, near a town, has a large commercial value, whether it has been lifted by the operations of nature and retained by ingenuity of man, or has been pumped up through costly engines and with great expenditure of fuel.

When such head pressures are secured at the expense of pumps and fuel, they are too costly to be squandered in friction in the pipes. Such frictional loss entails a corresponding daily expense of fuel so long as the works exist. In such case, the pipes may be economically increased in size until the daily frictional expense capitalized, approximates to the additional capital required to increase the given pipes to the next larger diameters.

The frictional head h'' in pipes under pressure, is found by the formula,

$$h'' = v^2 (4m) \frac{l}{2gd}. \quad (1)$$

The frictional head for a given diameter is as the square of the velocity, nearly (v^2m) and, for different diameters, inversely as the diameters.

The coefficient* m decreases in value as the velocity increases, and for a given velocity decreases as the diameter increases.

485. Table of Frictional Heads in Pipes.—The following table (No. 101, p. 493) we have prepared to facilitate frictional head calculations, and to show at a glance the frictional effect of increase of velocity, in given pipes from 4 to 36 inch diameters. The second and last columns show also the theoretical volume of delivery through clean, smooth pipes at different given velocities.

The fourth column gives approximate values of the coefficient m for given diameters and velocities, and for clean smooth pipes under pressure.

* *Vide* Table No. 62, page 248, of coefficients (m) for clean, slightly tuberculated, and foul pipes; also § 274, page 250, for formula of frictional resistance to flow.

TABLE No. 101.

FRICITIONAL HEAD IN MAIN AND DISTRIBUTION PIPES (in each

1000 feet length). $h'' = v^2 (4m) \frac{l}{2gd}$.

Diam. of pipe.	Volume of water delivered	Velocity of flow.	Coefficient of friction.	Frictional head per 1000 feet.	U. S. gallons in 24 hours.
<i>Inches.</i>	<i>Cu. ft. per min.</i>	<i>Feet per second.</i>		<i>Feet.</i>	<i>Gallons.</i>
4	5	.958	.00714	1.221	53,856
	7.5	1.437	.00695	2.675	80,784
	10	1.916	.00680	4.653	107,712
	12.5	2.394	.00666	7.114	134,640
	15	2.873	.00654	10.06	161,568
	17.5	3.295	.00644	13.03	188,496
	20	3.831	.00633	17.32	215,424
6	17.5	1.409	.00666	1.643	188,496
	20	1.701	.00655	2.355	215,424
	22.5	1.913	.00648	2.946	242,352
	25	2.126	.00646	3.628	269,280
	27.5	2.339	.00638	4.337	296,208
	30	2.551	.00634	5.126	323,136
	35	2.976	.00623	6.855	376,992
	40	3.401	.00615	8.838	430,848
	45	3.827	.00610	11.100	484,704
8	30	1.429	.00644	1.225	323,136
	35	1.685	.00635	1.680	376,992
	40	1.905	.00628	2.124	430,848
	45	2.143	.00620	2.654	484,704
	50	2.381	.00615	3.249	538,560
	55	2.619	.00609	3.893	592,416
	60	2.857	.00603	4.587	646,272
	65	3.095	.00600	5.356	700,128
	70	3.331	.00596	6.159	753,984
	75	3.571	.00592	7.035	807,840
	80	3.809	.00589	7.963	861,696
		85	4.048	.00586	8.948
	90	4.298	.00584	10.056	969,408
10	60	1.835	.00614	1.541	646,272
	70	2.141	.00606	2.071	753,984
	80	2.447	.00597	2.665	861,696
	90	2.752	.00590	3.331	969,408
	100	3.058	.00584	4.071	1,077,120
	110	3.364	.00578	4.876	1,184,832
	120	3.670	.00572	5.743	1,292,544
	130	3.976	.00569	6.706	1,400,256
	140	4.281	.00566	7.733	1,507,968
	150	4.587	.00562	8.815	1,615,680

TABLE No. 101—(Continued).

FRICTIONAL HEAD IN MAIN AND DISTRIBUTION PIPES (in each 1000 feet length).

Diam. of pipe.	Volume of water delivered.	Velocity of flow.	Coefficient of friction.	Frictional head per 1000 feet.	U. S. gallons in 24 hours.
<i>Inches.</i>	<i>Cu. ft. per min.</i>	<i>Feet per Second.</i>		<i>Feet.</i>	<i>Gallons.</i>
12	120	2.548	.00581	2.343	1,292,544
	140	2.972	.00571	3.133	1,507,968
	160	3.397	.00563	4.036	1,723,392
	180	3.821	.00555	5.033	1,938,816
	200	4.246	.00551	6.171	2,154,240
	220	4.637	.00546	7.407	2,369,664
	240	5.098	.00542	8.755	2,585,088
14	175	2.721	.00560	2.207	1,884,960
	200	3.109	.00553	2.845	2,154,240
	225	3.498	.00546	3.550	2,423,520
	250	3.887	.00542	4.359	2,692,800
	275	4.275	.00537	4.989	2,962,080
	300	4.665	.00538	6.232	3,231,360
	325	5.053	.00530	7.203	3,500,640
	350	5.597	.00524	8.738	3,769,920
	16	225	2.682	.00554	1.857
250		3.099	.00538	2.408	2,692,800
275		3.226	.00536	2.599	2,962,080
300		3.576	.00530	3.158	3,231,360
325		3.874	.00526	3.679	3,500,640
350		4.172	.00523	4.242	3,769,920
375		4.471	.00520	4.844	4,039,200
400		4.768	.00518	5.488	4,308,480
425		5.066	.00515	6.159	4,577,760
450		5.368	.00508	6.848	4,847,040
475		5.676	.00510	7.657	5,116,320
500		5.961	.00507	8.395	5,385,600
18		300	2.830	.00530	1.758
	350	3.301	.00519	2.342	3,769,920
	400	3.773	.00513	3.024	4,308,480
	450	4.245	.00508	3.791	4,847,040
	500	4.717	.00504	4.644	5,385,600
	550	5.188	.00499	5.562	5,924,160
	600	5.660	.00497	6.594	6,462,720
	650	6.132	.00495	7.708	7,001,280
	675	6.367	.00494	8.293	7,270,560

T A B L E 101—(Continued).

FRICITIONAL HEAD IN MAIN AND DISTRIBUTION PIPES (in each 1000 feet length).

Diam. of pipe.	Volume of water delivered.	Velocity of flow.	Coefficient of friction.	Frictional head per 1000 feet.	U. S. gallons in 24 hours.
<i>Inches.</i>	<i>Cu. ft. per min.</i>	<i>Feet per second.</i>		<i>Feet.</i>	<i>Gallons.</i>
20	350	2.674	.00516	1.375	3,769,920
	400	3.056	.00509	1.731	4,308,480
	450	3.438	.00503	2.215	4,847,040
	500	3.821	.00500	2.720	5,385,600
	550	4.202	.00496	3.264	5,924,160
	600	4.585	.00493	3.862	6,462,720
	650	4.967	.00490	4.505	7,001,280
	700	5.341	.00487	5.177	7,539,840
	750	5.731	.00484	5.924	8,078,400
	800	6.113	.00481	6.698	8,616,960
	850	6.572	.00479	7.710	9,155,520
900	6.878	.00477	8.409	9,694,080	
24	550	2.918	.00484	1.280	5,924,160
	600	3.183	.00482	1.517	6,462,720
	650	3.449	.00477	1.762	7,001,280
	700	3.714	.00475	2.035	7,539,840
	750	3.979	.00473	2.326	8,078,400
	800	4.245	.00471	2.636	8,616,960
	850	4.510	.00469	2.963	9,155,520
	900	4.775	.00467	3.307	9,694,080
	950	5.041	.00466	3.678	10,232,640
	1000	5.306	.00464	4.057	10,771,200
	1050	5.571	.00463	4.463	11,309,760
	1100	5.826	.00462	4.871	11,848,320
	1150	6.314	.00459	5.684	12,386,880
1200	9.367	.00457	5.754	12,925,440	
1250	6.633	.00455	6.218	13,464,000	
27	800	3.353	.00465	1.410	8,616,960
	900	3.772	.00461	1.811	9,694,080
	1000	4.192	.00457	2.217	10,771,200
	1100	4.611	.00453	2.659	11,848,320
	1200	5.030	.00451	3.150	12,925,440
	1300	5.454	.00449	3.687	14,002,560
	1400	5.868	.00447	4.250	15,079,680
	1500	6.287	.00445	4.856	16,156,800
	1600	6.707	.00443	5.502	17,233,920
1700	7.126	.00439	6.155	18,311,040	

TABLE No. 101—(Continued).

FRICTIONAL HEAD IN MAIN AND DISTRIBUTION PIPES (in each 1000 feet length).

Diam. of pipe.	Volume of water delivered.	Velocity of flow.	Coefficient of friction.	Frictional head per 1000 feet.	U. S. gallons in 24 hours.
<i>Inches.</i>	<i>Cu. ft. per min.</i>	<i>Feet per second.</i>		<i>Feet.</i>	<i>Gallons.</i>
30	1000	3.396	.00448	1.284	10,771,200
	1200	4.075	.00441	1.820	12,925,440
	1400	4.754	.00438	2.460	15,079,680
	1600	5.433	.00434	3.257	17,233,920
	1800	6.112	.00429	4.009	19,388,160
	2000	6.791	.00428	4.904	21,542,400
	2200	7.471	.00425	5.894	23,696,640
	2400	8.149	.00421	6.947	25,850,880
36	1500	3.536	.00419	1.085	16,156,800
	2000	4.708	.00412	1.891	21,542,400
	2500	5.894	.00406	2.920	26,928,000
	3000	7.073	.00401	4.154	32,313,600
	3500	8.252	.00397	5.598	37,699,200
	4000	9.431	.00394	7.257	43,084,800

486. Relative Discharging Capacities of Pipes.—

The volume of water delivered, q , by a pipe, is, as we have seen (§ 296), equal to the product of its section S , into its mean velocity of flow v ,

$$q = Sv.$$

The equation of velocity is,

$$v = \left\{ \frac{2gri}{m} \right\}^{\frac{1}{2}};$$

hence we have, for full pipes,

$$q = S \cdot \left\{ \frac{2gri}{m} \right\}^{\frac{1}{2}} = S \cdot \left\{ \frac{2gdi}{4m} \right\}^{\frac{1}{2}} = .7854d^2 \cdot \left\{ \frac{2gdi}{4m} \right\}^{\frac{1}{2}}.$$

By uniting the two terms of d , within the vinculum, we have the equation of volume,

$$q = \sqrt{2g} \cdot \left\{ \frac{.61685d^5i}{4m} \right\}^{\frac{1}{2}} = \sqrt{2gh} \cdot \left\{ \frac{.61685d^5}{4ml} \right\}^{\frac{1}{2}}. \quad (2)$$

For a given inclination, all the terms in the right-hand member are constant, except d and m . We have then the relative discharging powers of pipes, as the quotients, $\frac{d^{\frac{5}{2}}}{m}$, or nearly as the square roots of the fifth powers of the diameters.

By transposition of the equation for volume, q , we have the equation for diameter, d ,

$$d = \left\{ \frac{1}{2g} \times \frac{4q^2m}{.61685i} \right\}^{\frac{1}{5}} = \left\{ \frac{1}{2gh} \times \frac{4mlq^2}{.61685} \right\}^{\frac{1}{5}}. \quad (3)$$

By this we perceive that the relative diameters required for equally effective deliveries are as the products q^2m , or nearly as the squares of the volumes.

487. Table of Relative Capacities of Pipes.—The following table (No. 102) of approximate relative discharging powers of pipes, will facilitate the proper proportioning of systems of pipe distributions. It shows at a glance the ratio of the square root of the fifth power of any diameter, from 3 to 48 inches, to the square root of the fifth power of any other diameter within the same limit.

In the second column of this table, the diameter 1 foot is assumed as unit, and the ratios of the square roots of the fifth powers of the other diameters, *in feet*, are given opposite to the respective diameters in feet written in the first column. Thus the approximate relative ratio of discharging power of a 3-foot pipe to that of a 1-foot pipe is as 15.588 to 1; and of a .5 foot pipe to a 1-foot pipe as .1768 to 1; also the relative discharging power of a 4-foot pipe (= 48-inch) is to that of a 2-foot pipe (= 24-inch) as 32 to 5.657; and of

a 2.5-foot pipe to the combined discharging powers of a 2-foot and 1.5-foot pipes as 9.859 to $(5.657 + 2.756)$.

The last vertical column gives the diameters in inches, as does also the horizontal column at the head of the right-hand section of the table.

The numbers in the intersections of the horizontal and vertical columns from the diameters in inches give also approximate relative discharging capacities. For instance, if we select in the vertical column of diameters that of the 48-inch pipe and desire to know how many smaller pipes it is equal to in discharging capacity, we trace along the horizontal column from it, and find that it is equal to 15.59, sixteen-inch pipes, or 5.65 twenty-four-inch pipes, or 1.58 forty-inch pipes, etc. Also, for other diameters, we find that a 24-inch pipe is equal to 32 six-inch pipes, or 2.05 eighteen-inch pipes, and a 12-inch pipe is equal to 5.65 six-inch pipes.

488. Depths of Pipes.—The depths at which pipes are to be placed, so they shall not be injured by traffic or frost, is a matter for special local study, general rules being but partially applicable. The depth is controlled in each given latitude, or thermic belt, by first, the stability of the earth, whether it be soft and quaky, or heavy clay, or close sand, or rock; second, whether the ground be saturated by surface waters that remain and freeze and conduct down frost, or by living springs flowing up and opposing deep penetration of frost; third, whether the ground be porous, well underdrained to a level below the pipes, and the pores filled with air, which is a good non-conductor; and fourth, whether the winds sweep the snows off from given localities and leave them unprotected, or given localities are shaded and the severity of night is uncounteracted at noonday.

Along those *thermic lines* whose latitudes at the Atlan-

tic coast are as given, the depths of the axes of the pipes, in close gravelly soils, may be approximately as follows :

TABLE No. 103.

APPROXIMATE DEPTHS FOR AXES OF WATER-PIPES.

DIAM.	LATITUDE 40° North.	LATITUDE 42° North.	LATITUDE 44° North.	DIAM.	LATITUDE 40° North.	LATITUDE 42° North.	LATITUDE 44° North.
	<i>Depth of axis.</i>	<i>Depth of axis.</i>	<i>Depth of axis.</i>		<i>Depth of axis.</i>	<i>Depth of axis.</i>	<i>Depth of axis.</i>
"	' "	' "	' "	"	' "	' "	' "
4	4-8	5-2	6-2	20	4-10	5-5	6-3
6	4-8	5-2	6-2	22	4-10	5-5	6-3
8	4-7	5-1	6-2	24	4-11	5-6	6-4
10	4-7	5-1	6-2	27	4-11	5-7	6-4
12	4-7	5-1	6-2	30	5-0	5-8	6-4
14	4-7	5-2	6-2	33	5-0	5-9	6-5
16	4-8	5-3	6-2	36	5-0	5-10	6-6
18	4-9	5-4	6-3	40	5-1	5-11	6-7

There is a general impression that the water passed into pipes, will in a very short time take the temperature of the ground in which the pipes are laid. Close observation does not confirm this impression.

If water at a high temperature is admitted to a deep pipe system, in the early summer, while the ground is yet cool, the consumers will derive but little benefit from the coolness of the earth, and this is especially the case when the pipes are coated and lined with cement.

Frost also penetrates at various points as low as the bottoms of sub-mains, without seriously interfering with the flow, and water-pipes are often suspended beneath bridges, where ice forms in the river near by, a foot or more in thickness, without their flow being interfered with. An eight or ten inch pipe will resist cold a long time before it will freeze solid.

The hydrants, small dead ends, and service-pipes are

most sensitive to cold, and their depths and coverings should receive especial attention.

Dead ends should be avoided as much as possible, and circulation maintained for the protection of the pipes against frost, as well as to maintain the purity, or to prevent the fermentation of the motionless water.

489. Elementary Dimensions of Pipes.—A table of the elementary dimensions of pipes facilitates so much, pipe calculations, that we insert it here (p. 504). The last column gives also the quantity of water required to fill each lineal foot of the pipes, when laid complete, or the quantities they contain.

490. Distribution Systems.—We have now reduced to tabular form the data that will assist in establishing the proportions of the several parts of a system of distribution pipes, for the domestic and fire supply of a town or city.

For illustration, let us assume a case of a thriving young city of 25,000 inhabitants, situated on the bank of a navigable river, and that the contour of the land had permitted its streets to be straight, and to intersect at right-angles. In such case its system of distribution pipes will form a series of parallelograms, inclosing one, two or more of the city blocks, as circumstances require, substantially as is shown in the plan of a system of pipes, Fig. 113.

491. Rates of Consumption of Water.—The healthy growth of the city gives reason to anticipate an increase to 35,000 inhabitants within a decade, and this number at least should be provided for in the first supply main, the first reservoir, and such parts as are expensive to duplicate, and a larger number should be provided for in the conduit, and such parts as are very expensive and difficult to duplicate.

The continued popularization of the use of water, and

TABLE No. 104.

ELEMENTARY DIMENSIONS OF PIPES.

Diameter	Diameter.	Contour.	Sectional area.	Hydraulic mean radius.	Cubical contents per lineal foot.
<i>Inches.</i>	<i>Feet.</i>	<i>Feet.</i>	<i>Sq. feet.</i>		<i>Cubic feet.</i>
$\frac{1}{2}$.0417	.1310	.001366	.0104	.001366
$\frac{3}{4}$.0625	.1965	.003068	.0156	.003068
1	.083	.2618	.005454	.0208	.005454
$1\frac{1}{2}$.1250	.3927	.01227	.0312	.01227
$1\frac{3}{4}$.1458	.4581	.01670	.0364	.01670
2	.1667	.5235	.02232	.0418	.02232
3	.250	.7854	.04909	.0625	.04909
4	.3333	1.047	.08726	.0833	.08726
6	.5000	1.571	.19635	.1250	.19635
8	.6667	2.094	.3490	.1666	.3490
10	.8333	2.618	.5454	.2083	.5454
12	1.0000	3.142	.7854	.2500	.7854
14	1.1667	3.665	1.069	.2916	1.069
16	1.3333	4.189	1.397	.3333	1.397
18	1.5000	4.713	1.767	.3750	1.767
20	1.6667	5.235	2.181	.4166	2.181
24	2.0000	6.283	3.142	.5000	3.142
27	2.2500	7.069	3.976	.5625	3.976
30	2.5000	7.854	4.909	.6250	4.909
33	2.7500	8.639	5.940	.6875	5.940
36	3.0000	9.425	7.069	.7500	7.069
40	3.3333	10.47	8.726	.8333	8.726
44	3.6667	11.52	10.558	.9166	10.558
48	4.0000	12.56	12.567	1.0000	12.567
54	4.5000	14.14	15.905	1.1250	15.905
60	5.0000	15.71	19.635	1.2500	19.635
72	6.0000	19.29	29.607	1.5000	29.607
84	7.0000	21.99	38.484	1.7500	38.484
96	8.0000	25.45	50.265	2.0000	50.265

FIG. 113.

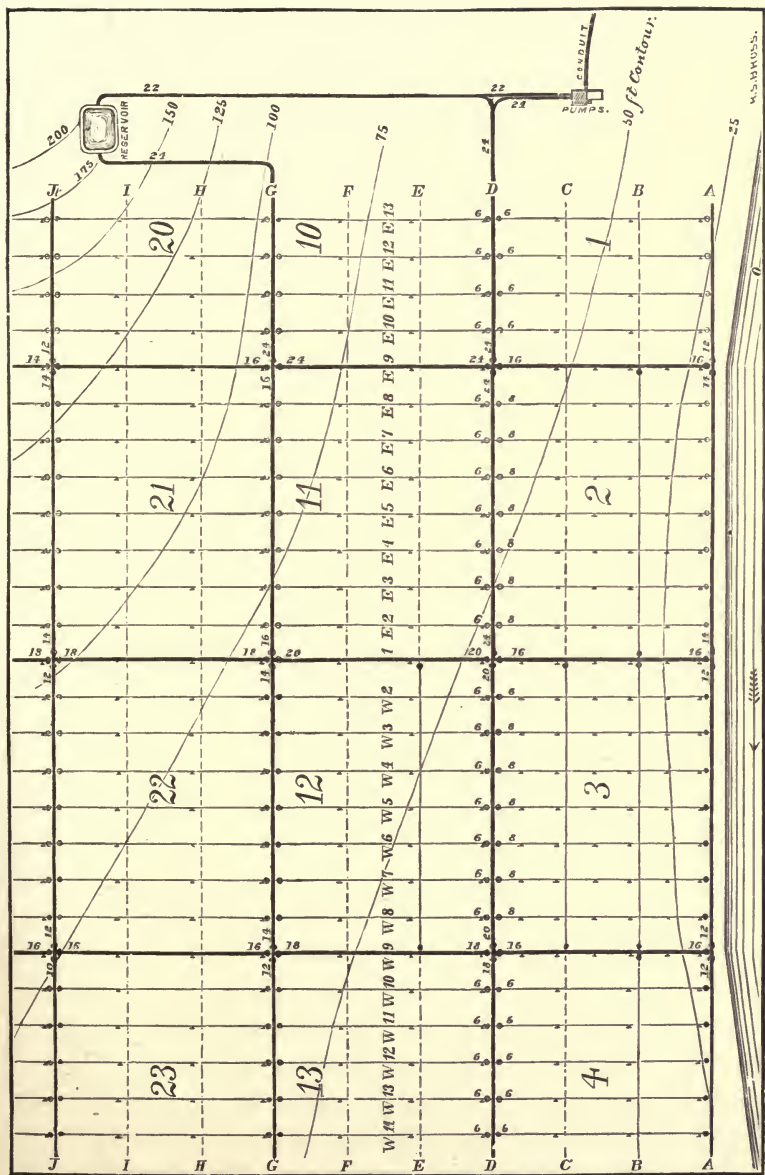

PLAN OF A DISTRIBUTION SYSTEM.

the increasing demand for it for domestic, irrigating, ornamental, and mechanical purposes, with the increasing waste to which they all tend, requires that at least an annual average of 75 gallons per capita daily must be provided for the 35,000 persons.

In our discussion of the varying consumption of water (§ 19), it is shown that in certain seasons, days of the week, and hours of the day, the rate of consumption, independent of the fire supply, is *seventy-five* per cent. greater than the average daily rate for the year. In anticipation of this varying rate, we should proportion our main for not less than *fifty* per cent. increase ($= 75 \times 1.50 = 112.5$), or for a rate of 112.5 gallons per capita daily, which for 35,000 persons equals a rate of 365 cubic feet per minute.

492. Rates of Fire Supplies.—For fire supply we anticipate the possibility of two fires happening at the same time requiring ten hose streams each. The minimum fire supply estimate is, then, twenty hose streams of say 20 cubic feet per minute, or a total of 400 cubic feet per minute.

The combined *rate* of flow of fire and domestic supply is $(365 + 400)$ 765 cubic feet per minute.

493. Diameter of Supply Main.—Turning now to the table of Frictional Head in Distribution Pipes, and looking for volume in the second column, we find that a 24-inch pipe will deliver 765 cubic feet per minute, with a velocity of flow of about 4 feet per second, and with a loss of head of about 2.5 feet in each thousand feet length of main. A 20-inch pipe will deliver the same volume with a velocity of flow of about 5.75 feet per second, and with a loss of head of about 6 feet in each thousand feet length. Unless the main is short, this velocity, and this loss of head, increased by the loss at angles and valves, is too great. We adopt, therefore, the 24-inch diameter for supply main.

494. Diameters of Sub-Mains.—We now compute the portions of the whole supply that will be required in each section of the city. If our plan of distribution is divided into twelve sections, then the *average* section supply is one-twelfth of the whole. We find, for instance, that Sec. 1 requires 85 per cent. of the average; Sec. 3, 125 per cent. of the average; Sec. 12, 100 per cent. of the average; Sec. 22, 95 per cent. of the average, etc.

Now, with the aid of the table of relative discharging powers of pipes, and the table of frictional heads in pipes, we can readily assign the diameters to the sub-mains that are to distribute the waters to the several sections, adding to the domestic and fire supply volumes for the nearest sections the estimated volumes that are to pass beyond them to remoter sections.

This done, we may sum up the frictional losses of head along the several lines from the supply to any given point, and deduct the sum from the static head, and see if the required *effective head* remains. The *volume* and *effective head* are matters of the utmost importance, when the pipes are depended upon exclusively to supply the waters required for fire extinguishment. The *lack* of these has cost several of our large cities a million dollars and more in a single night.

An inspection of the table of Frictional Head shows how rapidly the friction increases when velocity increases. The increase of frictions are, in the same pipe, as the increase of squares of velocities (v^2m), nearly.

495. Maximum Velocities of Flow.—As a general rule, the velocities in given pipes should not exceed, in feet per second, the rates stated in the following table for the respective diameters.

TABLE No. 103.

MAXIMUM VELOCITIES OF FLOW IN SUPPLY AND DISTRIBUTION PIPES.

Diameter, in inches.....	4	6	8	10	12	14	16	18	20	22	24	27	30	33	36
Velocity, in ft. per sec..	2.5	2.8	3	3.3	3.5	3.9	4.2	4.5	4.7	5	5.3	5.8	6.2	6.6	7

496. Comparative Frictions.—As regards friction alone in any given pipe, it does not matter whether the water is flowing up a hill or down a hill, or materially if the pressure is great or little; or in long, conical, and smooth pipes, whether the water is flowing toward the large end or toward the small end. The total friction will be the same in both directions in the first case, and will also be the same in both directions in the last case. In the conical pipe, however, the friction per unit of length, or per lineal foot, will be less than the average at the large end, because the velocity of flow will be less there, and more than the average at the small end. The total frictional head will be the same as though the whole pipe had a uniform diameter just equal to the diameter in the conical pipe at the point where the friction is equal to the average for the whole length.

497. Relative Rates of Flow of Domestic and Fire Supplies.—The actual consumption of water by the fire department for the extinguishment of fires, in any city, per annum, is very insignificant when compared with either the domestic, the irrigation and street sprinkling, or the mechanical supply for the same limit of time, yet it has appeared above that the pipe capacity required for the fire service, in the general main of a small city, exceeds that required for the whole remaining consumption. If we examine this question still closer, taking a length of 1200 feet of distribution pipe in a closely built up section of the

city, we find on the 1200 feet length, say 40 domestic service pipes, and consumption of say 750 gallons each per day, or total of 15000 gallons per day. Making due allowance for fifty per cent. increase of flow at certain hours, we have a required delivery capacity of 1.5 cubic feet per minute to cover this whole consumption. On the same 1200 feet of pipe there are, say four fire-hydrants. If in case of fire we take from these hydrants only four streams, in all, of 20 cubic feet per minute each, we require a delivery capacity of 80 cubic feet per minute. In this case, which is not an uncommon one, the required capacity for the fire service is to that for the remaining service as 80 to 1.5.

If the given pipe, 1200 feet long, is a six-inch pipe, supplied at both ends, then the delivery for fire at each end is forty cubic feet per minute. Referring to the table of frictional head, we find that this quantity requires a velocity of flow of 3.401 feet per second, and consumed head, in friction, at the rate of 8.8 feet per thousand feet.

If the 80 cubic feet per minute must all come from one end of the pipe, then the pipe should be eight inches diameter, in which case the velocity will be nearly four feet per second and the head consumed at the rate of about eight feet per thousand feet length.

498. Required Diameters for Fire Supplies.—As a general rule, the minimum diameters of pipes for supplying given numbers of hydrant streams, when the given pipes are one thousand feet long, and static head of water one hundred and fifty feet, are as follows :

TABLE No. 106.

DIAMETERS OF PIPES FOR GIVEN NUMBERS OF HOSE STREAMS.

Number of hose streams.....	1	2	3	4	5	6	7	8	9	10	11	12
Approximate total quantity of water, in cubic feet per minute.....	20	40	60	80	100	120	140	160	180	200	220	240
Required diameter of pipe, in inches..	4	6	8	8	10	10	10	12	12	12	12	14
Number of hose streams.....	13	14	15	16	17	18	19	20	21	22	23	24
Approximate total quantity of water, in cubic feet per minute.....	260	280	300	320	340	360	380	400	420	440	460	480
Required diameter of pipe, in inches..	14	14	14	16	16	16	16	16	16	18	18	18

If the pipes are short, the velocities of flow may be increased somewhat, for a greater ratio of loss of head per unit of length is then permissible.

If the pipe is supplied from both ends, then the number of hose streams may be doubled without increase of the frictional head ; hence the advantage of so distributing the sub-mains as to deliver a double supply to as many points as possible, for this is equivalent to doubling the capacity of the minor pipes. If the pipes are several thousand feet long, and have a large proportionate domestic draught, then a due increase should be given to the diameters.

499. Duplication Arrangement of Sub-Mains.—

When the sub-mains can be distributed in parallel lines, at several squares distance, and “gridironed” across by the smaller service mains, as in the plan, Fig. 113, or arranged in some equivalent manner, then a most excellent system will be secured. In such case, if an accident happens to a pipe, or valve, or hydrant, in any central location, there are at least two lines of sub-mains around that point, and the supply will with certainty be maintained at points beyond.

Pipes are always liable to accident in consequence of building excavations, sewerage excavations, sewer overflows, quicksand or clay slides, floods, and various other causes that cannot be foreseen when the pipes are laid ; and

when new hydrants are to be attached, or large pipe connections to be made, or repairs to be made, it is frequently necessary to shut off the water. The advantage of duplicate lines of supply to all points is apparent in such case. When a city has become dependent on its pipes for its water supply and protection from fire, it is absolutely necessary that the supply be maintained, and the result may be disastrous if it fails for an hour.

500. Stop-Valve System.—It is equally advantageous to have a sufficient number of stop-valves, or “gates,” as they are frequently termed, upon the pipe, so the water may be shut off from any given point without cutting off the supply from both a long and a broad territory, or even a very long length of pipe. The sub-main parallelogram system shown in the plan, Fig. 113, permits of such an arrangement of stop-valves, chiefly of small diameters and inexpensive, that an accident at any point will not leave that point without a tolerable fire protection from both sides. For instance, if it is necessary to shut off in Section 2 a part of East Fourth Street between Avenues A and D, the hydrants at

FIG. 118.

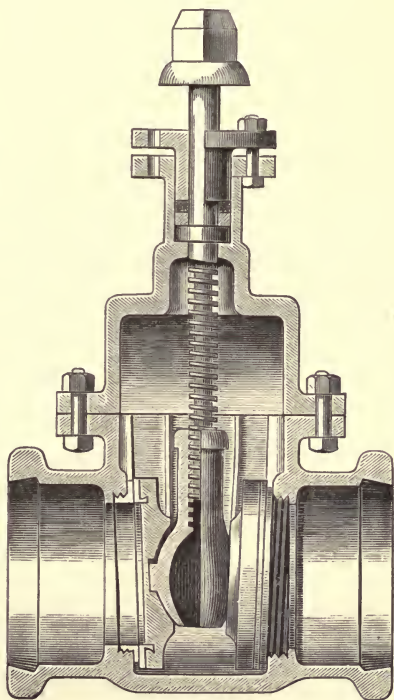

EDDY'S STOP-VALVE.

(R. D. Wood & Co., Philadelphia.)

the corners of East Third and Fifth Streets will still be available. If the gates are placed at each branch from the sub-mains, and at the intersections of the sub-mains, as they should be, then an accident to a sub-main will not necessitate the shutting off of any service-main joining it, for the service-main supplies can be maintained from the opposite ends. Wherever cross service-mains are required, as in Avenues B and C, in Section 3 in the plan, they may pass under the other service-mains whose lines they cross and have gates at their end branches only, which admits of their being readily isolated.

501. Stop-Valve Locations.—A systematic disposition of the pipes generally should be adopted. If the pipes are not placed in the *centres* of streets, they should be placed with strict uniformity at some *certain distance* from the centre of the street, and carefully aligned, and uniformly upon the same geographical side, as, upon the northerly and westerly side. The stop-valves should be disposed also, with rigid system, as, always in the line of the street boundary, the line of the curb, or some fixed distance from the centre of the street. An accident may demand the prompt shutting of any gate of the whole number, at any moment of day or night; and if, perchance, its curb-cover is hidden by frozen earth or by snow, it is important to know exactly where to strike without first journeying to the office and searching for a memorandum of distances and bearings. Searching for a gate-cover buried under frozen earth is a tedious operation, and it is not always possible to uncover every one of several hundred gates after every thaw and every snow-storm in winter.

Strict adherence to a system in locating gates enables new assistants to readily learn and to know the exact position of them all.

Strict adherence to system in locating pipes is requisite for the strict location of gates, and pipes should be cut, if necessary, to bring the gates to their exact locations. If a gate is a half-length of pipe out of position, it may cost several hours delay in digging earth frozen hard as a sandstone rock, to find the gate-cover.

502. Blow-off, and Waste Valves.—When pipes are located upon undulating ground, blow-off valves and pipes will be required in the principal depressions of the mains and sub-mains, to flush out the sediment that is deposited from unfiltered water. The diameters of the blow-off pipes may be about half the diameters of the mains from which they branch. Smaller wastes will answer for the drainage of the service-main sections for repairs or connections, and these may lead into sewers, or wherever the waste-water may be disposed of.

503. Stop-Valve Details.—A variety of styles of stop-valves are now offered by different manufacturers, and a special advantage is claimed for each, so that no little practical sagacity is required on the part of the engineer to protect his works from the introduction of weak and defective novelties, that may prove very troublesome.

He must observe that the valve castings are so designed as to be strong and rigid in all parts, that there are no thin spots from careless centring of cores; that flat parts, if any, are thickened up, or ribbed, so they will not spring; that the valve-disks are so supported as not to spring under great pressures, and that they and their seats are faced with good qualities of bronze composition and smoothly scraped, ground, or planed, and that they will not stick in their seats; that the valve-stems are particularly strong and stiff, with strong square or half-V threads, and that they and their nuts are of a tough bronze or aluminum composition.

FIG. 119.

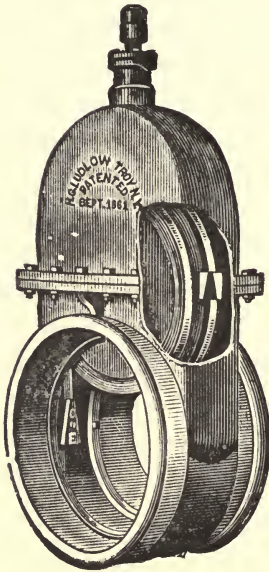

FIG. 119a.



LUDLOW'S STOP-VALVE—(Ludlow Manufacturing Co., Troy).

Figs. 114 to 119a illustrate the principal features of valves that have been well introduced.

A majority of the good valves have double disks, that are self-adjusting upon their seats, and their seats are slightly divergent, so that the pressure of the screw can set the valve-disks snug upon the seats.

The loose disks should have but a slight rocking movement between their guides, and must not be permitted to chatter when the valve is partially open.

The blow-off valves may be solid or single-disk valves, but the valves in the distribution must be tight against pressure from both and either sides, whether the difference of pressure upon the two sides be much or little.

Valves exceeding twenty inches diameter are usually placed upon their sides, except in chambers, and the disks have lateral motions, or sometimes the valve-cases are so

arranged that the disks have vertical downward motions. Otherwise the water in the valve-domes would be too much exposed to frost in winter, as it would rise nearly to the ground surface.

504. Valve Curbs.—The stop-valve curbs are sometimes of chestnut or pitch-pine plank, with strong cast-iron covers, and sometimes of cast-iron, placed upon a foundation of bricks laid in cement.

The plank curbs are about eighteen by twenty-four inches dimensions at top, flaring downward according to

FIG. 120.

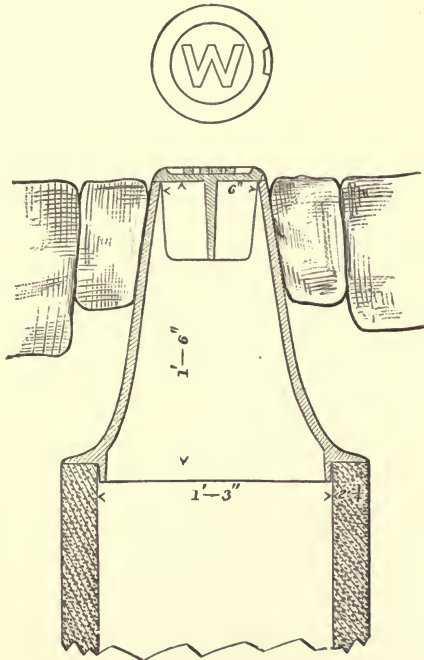

the size of the valve, and they are often of such dimensions as to admit a man, with room to enable him conveniently to renew the packing about the valve-stem.

The cast-iron curbs are usually elliptical in section. The writer has used in several cities, for the smaller gates, up to twelve inches diameter, circular curbs (Fig. 120) of *beton coignet*, with cast-iron necks and covers. The neck is six inches clear diameter at the road surface, fifteen to eighteen inches deep, according to the size of the valve, and flares to the size of the cement curb, which is just large enough to slip over the dome-flange of the valve-case. The cement curb rests upon a foundation of brick or stone laid in cement mortar.

When these are paved about, the whole surface exposed is only seven and one-half inches diameter, and they are not as objectionable in the streets as the larger covers.

All gate-curbs must be thoroughly drained, so that water cannot stand in them, and freeze in winter.

505. Fire-Hydrants.—The design of a fire-hydrant that is a success in every particular is a great achievement. It ranks very nearly with the design of a successful water-meter.

Nearly every speculative mechanic, it would seem, who has had employ in a machine-shop for a time, has felt it his duty to design the much-needed successful hydrant; as so many doctors and lawyers have grappled with, and believed for a time, that they had solved the great meter problem.

Innumerable patterns of hydrants are urged upon water companies and engineers, and are accompanied by an abundance of certificates setting forth their excellence; and many of them have good points and will answer all practical purposes until an emergency comes, when they fail, and the experiment winds up with a loss that would have paid for a thousand reliable hydrants.

A considerable practical experience with hydrants, and

an expert knowledge of the qualities demanded in the design and materials of a hydrant, are necessary to enable one to judge at sight of the value of a new pattern.

506. Post-Hydrants.—In the smaller towns and in the suburbs of cities, *post-hydrants*, of which Fig. 121 illustrates one pattern, are more generally preferred, as they are more readily found at night, and are usually least expensive in first cost.

They are placed on the edge of the sidewalk, and a branch pipe from the service main furnishes them with their water. If the service main is of sufficient capacity, the post-hydrant may have one, two, three, or four nozzles. In cities where steam fire-engines are used, a large nozzle is added for the steamer supply, and if there is a good head pressure, two nozzles are usually supplied for attaching leading hose.

For the supply of two hose streams, or a steamer throwing two or more streams, the hydrant requires a six-inch branch pipe from the service main, and a valve of equal capacity. The supply to post-hydrants has too often been throttled down, when there was no head pressure to spare, and the effectiveness of the hydrant very much reduced thereby.

507. Hydrant Details.—In New England and the Northern States, a *frost-case* is a necessary appendage to a post-hydrant, and it must be free to

FIG. 121.

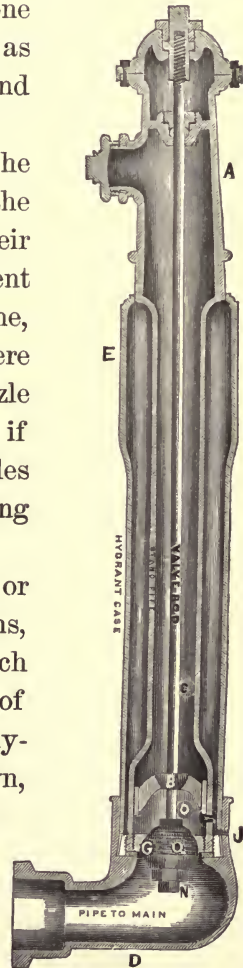

MATHEW'S HYDRANT—
(R. D. Wood & Co.,
Philadelphia.)

move up and down with the expansion and contraction of the earth, without straining upon the hydrant base. In clayey soils, these frost cases are often lifted several inches in one winter season, and if the post is not supplied with the movable case in such instances, it is liable to be torn asunder.

A waste-valve must be provided in every hydrant that will with certainty drain the hydrant of any and all water it contains as soon as the valve is closed, and the waste must close automatically as soon as the valve begins to open.

The main valve must be *positively tight*, or great trouble will be experienced with the hydrant in severe winters. A moderate leakage, as in some stop-valves, cannot be permitted. A free drainage must be provided to pass away the waste water from the hydrant, or, if the hydrant is frequently opened, for testing or use, the ground will soon become saturated and the hydrant cannot properly drain.

If the valve closes "with" the pressure there must be no slack motion of its stem, or when the valve is being closed and has nearly reached its seat, the force of the current will throw it suddenly to its seat and cause a severe water-ram.

The screw motion of hydrant valves must be such that the hydrant cannot be suddenly closed, or with less than ten complete revolutions of the screw. The valves should move slowly to their seats in all cases, as, if several hydrants happen to be closed simultaneously, the water-ram caused thereby may exert a great strain upon the valves, and the shock will be felt to some extent throughout the whole system of pipes. The sudden closing of a hydrant may make a gauge, attached to the pipes, that is more than a mile distant, kick up fifty or sixty pounds.

If a hydrant branch is taken from a main-pipe or sub-main, there should be a stop-valve between the main and hydrant, so the hydrant may be repaired without shutting off the flow through the main.

In 1874 the writer made some measurements of the quantities of water delivered, under different heads, through Boston Machine Co. Post Hydrants, which are similar in form to the Mathews Hydrant (Fig. 121). The volume of water was measured by passing it through a 3-inch Union water-meter, which was connected to each hydrant by a length of fire-hose.

The length of hose between the hydrant and meter in each and every experiment was 49 feet 10 inches. The bores of the hydrant nozzles and of the hose and meter couplings were two and one-quarter inches diameter. The hydrant branches were six inches in diameter, and hydrant barrels four and one-half inches diameter. The lengths of hose given, following, were in all cases beyond the meter, and were attached to the meter.

The hydrant was filled with water and pressure without flow, taken by a gauge just previous to the beginning of each test.

The following tests, at different elevations, covers a range of head pressures between 42 feet and 183 feet :

FIG. 122.

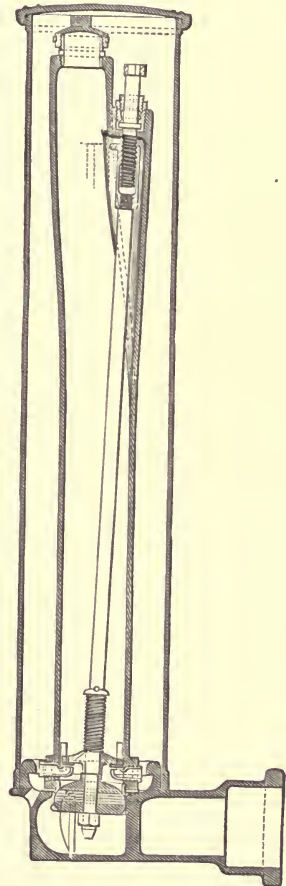

FLUSH HYDRANT.

FIG. 123.

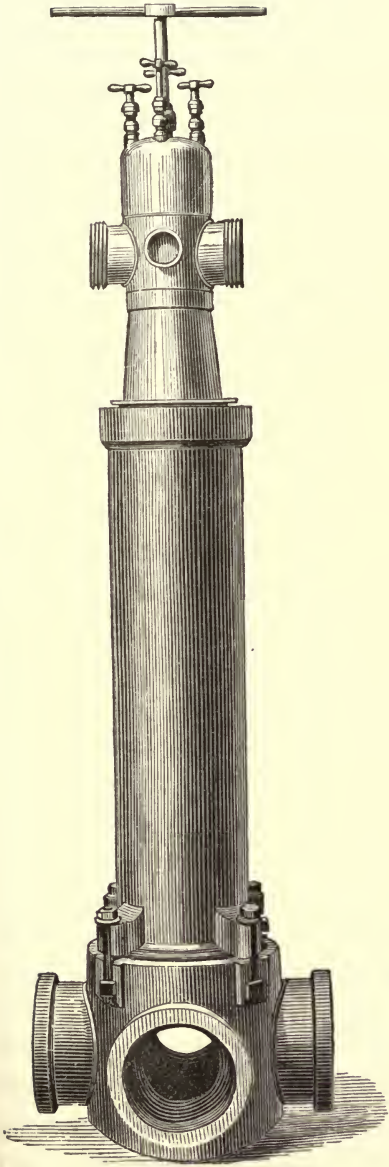
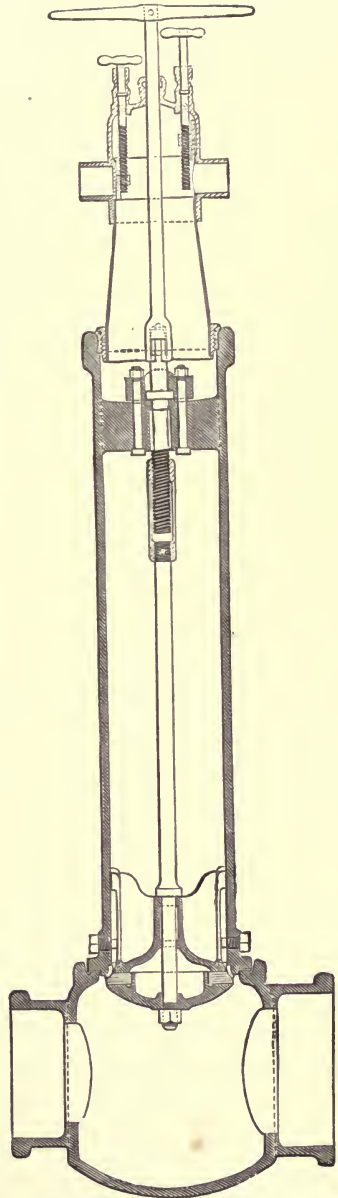

FIG. 124.



LOWRY'S FLUSH HYDRANT.—(Boston Machine Co., Boston.)

strength, and is usually carried upon the steamer or the hose carriage. It has any desired number of nozzles, from one to eight, each of which has its independent supplementary valve.

In the centre of the portable head is a revolving key that operates the main valve stem.

509. Gate Hydrants.—A variety of metallic “gate” hydrants have been introduced, from time to time, and had a brief existence, but the majority of them have been soon abandoned. The most minute particle of grit upon their faces gives trouble, and they are much more likely to *stick* than valves of good sole-leather or of rubber properly prepared, and clamped between metallic plates. Gate hydrants of good design and excellent workmanship, should be fully successful with filtered water.

The rubber of valves requires to be very skillfully tempered, or it will be too soft or too hard. It hardens, also, as the temperature of the water lowers.

510. High Pressures.—But a few years since the maximum static strain upon hydrants, in public water supplies, did not exceed that of a hundred and fifty feet head, and the majority of the hydrants in each system had not over one hundred feet pressures when the water was at rest. Hand or steam fire-engines were necessities in such cases, and the pipes were so small that often the engines had to exert some suctions on the pipes to draw their full supplies. Now the values of pressure that will permit six or eight effective streams to be taken direct from the hydrants in any part of the system is more fully appreciated, and direct pumping pressures equivalent to three or four hundred feet head are not uncommon. The effect upon the hydrants is, however, a greatly increased strain which they must be able to meet.

511. Air-Valves.—All water contains some atmospheric air. When water has passed through a pumping-engine into a force-main under great pressure, it absorbs some of the air in the air-vessel. If, then, it is forced along a pipe having vertical curves and summits at different points, it parts with some of the air at those summits. In time, sufficient air will accumulate at each summit to occupy a considerable part of the sectional area at that point, and it will continue to accumulate until the velocity of the water is sufficient to carry the air forward down the incline.

At such summits an *air-valve* is required to let off the accumulated air, as occasion requires. Also, when the water is drawn off from the pipes, as for repairs or any other purpose, there is always a tendency to a vacuum at the summits if no air is supplied there; and if the pipes are not thick and rigid, they may collapse in consequence of the vacuum strain, or exterior pressure.

When pipes are being filled, there should always be ample escape for the air at the summits, or the air contained in the pipes will be compressed and recoil, again be still more compressed and again recoil with greater force, shooting the column of water back and forth in the pipe with enormous force, and straining every joint.

In the distribution, hydrants are usually located upon summits, and in such case will perform the functions of air-valves.

If a stop-valve is inserted in an inclined pipe, and is closed during the filling of the section immediately below it, it makes practically a summit at that point, and an air-valve or vent will be required there.

An air and vacuum valve, for summits, may with advantage be combined in the same fixture, the air-valve motion being positive in action for the purpose of an air-valve,

opening against the pressure, but automatic as a vacuum-valve, opening freely to the pressure of the atmosphere.

Fig. 125 is a combined air and vacuum valve designed by the writer, and used in several cities with success.

A two-inch air-valve answers tolerably for four, six, eight, and ten inch pipes, but for large pipes a special branch with stop-valve may be used.

Great care should be exercised in filling pipes with water, and the water should not be admitted faster than the air can give place to it by issue at the air-valves, or open hydrant nozzles, without reactionary convulsions.

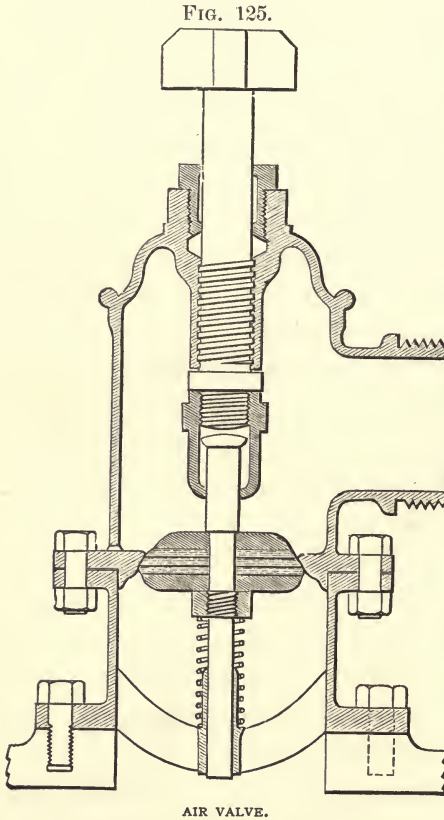

512. Union of High and Low Services.—Many cities have high lands within their built-up limits that are so much elevated above the general level that it is a matter of convenience to divide the distribution into “*high*” and “*low services*,” and to give to each its independent reservoir.

In such case the benefit of the pressure of the high reservoir may be secured in the *low* system in case of a large fire, by simply opening a valve in a branch connecting the

two systems. A check-valve, Fig. 126, will be required in the effluent pipe, or supply main from the lower reservoir to prevent the flow back into the lower reservoir.

A weighted valve, automatic in action, may also be placed in the branch connecting the two systems, and then

FIG. 126.

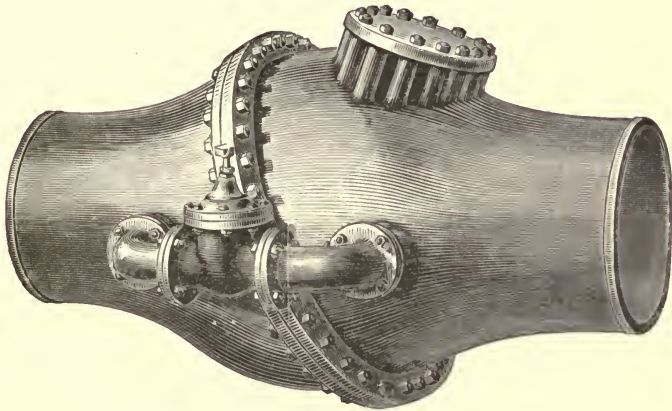

CHECK-VALVE.

in case of an accident to the supply pipe of the lower system, or a malicious closing of its valve, the upper service will maintain the supply at a few pounds diminished pressure.

If the pumps are arranged so as to give a direct increased pressure in the lower system for fire purposes, then a check-valve in the branch connecting the two systems, opening toward the high system, will be an excellent relief and protection against undue pressure.

513. Combined Reservoir and Direct Systems.—In the plan of a pipe system, Fig. 113, a pipe leads from the pumps direct to the reservoir, and a second pipe leads direct from the pumps into the distribution, so that water may be sent either to the reservoir or to the distribution, at will.

A branch pipe connects these two pipes so as to supply the distribution from the force main.

A check-valve opening toward the distribution is placed in this branch. If a fire-pressure is put upon the distribution through the direct pipe this valve prevents the flow back toward the reservoir, but upon the reduction of the fire-pressure it comes into action and maintains the supply to the distribution from the reservoir.

For additional security against unforeseen contingencies, another pipe may lead from the reservoir to one of the principal sub-mains, as shown in the plan, when the relative positions of the reservoir and distribution permits, and this pipe may contain in the effluent chamber a check-valve against fire-pressure and a weighted relief-valve to prevent undue pressure.

In the reservoir plan, Fig. 58 (page 333), the force and supply mains are shown to be connected by a pipe passing along the side of the reservoir, so that the water may be sent from the pumps direct into the distribution. The supply-main has a check-valve in the effluent chamber in this case.

A combined reservoir and direct pressure system, substantially like that of Fig. 113, including high and low services, was designed by the writer for one of the large New England cities in 1872, and the same was constructed with the exception of the high service reservoir, in the two following seasons.

514. Stand-Pipes.—Several of the American cities, whose reservoirs are distant from their pumping stations, have placed a stand-pipe upon their force-main, to equalize the resistance against the pumps, as in St. Louis, Louisville, and Milwaukee. Other cities use tall open-topped stand-pipes without reservoirs, when no proper site for a reservoir is readily attainable, as at Chicago and Toledo.

All the American stand-pipes now in use are of the

single leg class. The city of Sandusky, Ohio, has now (Nov. 1876) in process of construction a tank stand-pipe of 25 feet diameter and 208 feet height, surrounding a delivery stand-pipe of 3 feet diameter and 225 feet height. This tank is being built up of riveted metal plates, from designs by J. D. Cook, Esq., chief engineer. In Europe, the stand-pipes are more frequently double-legged, with connections between the up and down legs at intervals of height.

The stand-pipes as generally used, serve as partial substitutes for relief-valves combined or acting in conjunction with tall and capacious air-chambers. The surface of the water in the stand-pipes vibrates up and down according to the rate of delivery into them from the pumps, and the rate of draught, if the main over which they are placed is connected with the distribution. In northern cities it is necessary that they be housed and protected from frost.

The Boston Highlands Stand-pipe (page 161) stands upon an eminence 158 feet above tide, is of wrought-iron, and is 80 feet high, and 5 feet interior diameter. It is inclosed in a masonry tower.

The Milwaukee stand-pipe (page 25) rises to 210 feet above Lake Michigan, and the Toledo stand-pipe (page 31) to 260 feet above Maumee River.

515. Frictional Heads in Service-Pipes.—The following shows the *frictional head* in clean, smooth service-pipes, with given velocities, for *each one-hundred feet length*.

The numbers of the first column are the given velocities, in feet per second. The second column gives the head, which is necessary to generate the given velocities opposite.

In the first column, under each of the given diameters from $\frac{1}{2}$ inch to 4 inches, is the volume of flow, at its given velocity; in the next column the corresponding coefficient of friction; and in the next column the frictional head per each one hundred feet length at its given velocity.

TABLE No. 108.

FRICITIONAL HEAD IN SERVICE PIPES* (in each 100 feet length).

$$h'' = v^2 (4m) \frac{l}{2gd}$$

Velocity, in feet per second.	½ IN. DIAMETER			¾ IN. DIAMETER.			1 IN. DIAMETER.			1½ IN. DIAMETER.			
	Velocity head, in feet.	Cubic feet per minute.	Coefficient.	Frictional head.	Cubic feet per minute.	Coefficient.	Frictional head.	Cubic feet per minute.	Coefficient.	Frictional head.	Cubic feet per minute.	Coefficient.	Frictional head.
				<i>Feet.</i>			<i>Feet.</i>			<i>Feet.</i>			<i>Feet.</i>
1.4	.030	.0115	.00992	2.896	.0257	.00930	1.812	.0458	.00882	1.289	.1030	.00843	.821
1.6	.040	.0130	.00942	3.592	.0294	.00890	2.265	.0523	.00854	1.630	.1178	.00823	.955
1.8	.050	.0147	.00900	4.344	.0331	.00856	2.766	.0589	.00830	2.005	.1325	.00806	1.268
2.0	.062	.0164	.00862	5.136	.0368	.00830	3.300	.0654	.00810	2.416	.1472	.00790	1.570
2.2	.075	.0180	.00845	6.091	.0405	.00811	3.902	.0719	.00790	2.851	.1619	.00775	1.864
2.4	.090	.0196	.00810	6.950	.0442	.00792	4.534	.0785	.00773	3.320	.1766	.00760	2.175
2.6	.105	.0213	.00788	7.935	.0478	.00773	5.193	.0850	.00758	3.821	.1914	.00745	2.520
2.8	.122	.0229	.00770	8.993	.0515	.00759	5.891	.0916	.00745	4.356	.2061	.00730	2.844
3.0	.140	.0246	.00753	10.07	.0552	.00745	6.664	.0981	.00734	4.926	.2209	.00722	3.229
3.2	.160	.0262	.00745	11.36	.0589	.00737	7.501	.1046	.00720	5.544	.2356	.00714	3.634
3.4	.180	.0278	.00730	12.87	.0626	.00729	8.337	.1112	.00720	6.207	.2503	.00706	4.066
3.6	.202	.0295	.00729	14.01	.0662	.00718	9.038	.1177	.00714	6.900	.2651	.00700	4.509
3.8	.225	.0311	.00726	15.63	.0699	.00714	10.25	.1243	.00708	7.624	.2798	.00696	4.994
4.0	.250	.0328	.00722	17.21	.0736	.00710	11.29	.1309	.00702	8.376	.2945	.00692	5.502
4.2	.275	.0344	.00719	18.39	.0773	.00706	12.38	.1374	.00698	9.182	.3092	.00687	6.022
4.4	.302	.0360	.00715	20.63	.0810	.00702	13.51	.1440	.00694	10.02	.3239	.00683	6.571
4.6	.330	.0377	.00711	22.41	.0846	.00699	14.70	.1505	.00690	10.90	.3387	.00680	7.149
4.8	.360	.0393	.00708	24.30	.0883	.00696	15.94	.1571	.00687	11.80	.3534	.00677	7.751
5.0	.390	.0410	.00704	26.22	.0920	.00693	17.22	.1636	.00684	12.75	.3681	.00675	8.386
5.2	.422	.0426	.00701	28.24	.0957	.00689	18.52	.1701	.00681	13.73	.3828	.00671	9.017
5.4	.455	.0442	.00698	30.32	.0993	.00686	19.88	.1767	.00678	14.74	.3975	.00668	9.680
5.6	.490	.0459	.00695	32.47	.1030	.00683	21.29	.1832	.00675	15.79	.4123	.00665	10.37
5.8	.525	.0475	.00692	34.76	.1067	.00680	22.74	.1898	.00672	16.86	.4270	.00662	11.07
6.0	.562	.0492	.00689	36.96	.1104	.00678	24.26	.1963	.00670	17.99	.4417	.00660	11.81
6.2	.600	.0508	.00686	39.23	.1141	.00675	25.79	.2028	.00667	19.12	.4564	.00657	12.55
6.4	.640	.0524	.00683	41.67	.1177	.00672	27.35	.2094	.00664	20.28	.4711	.00654	13.31
6.6	.680	.0541	.00681	44.09	.1214	.00669	28.96	.2159	.00661	21.47	.4859	.00652	14.11
6.8	.722	.0557	.00678	46.70	.1251	.00666	30.61	.2225	.00659	22.72	.5006	.00650	14.94
7.0	.765	.0574	.00675	49.27	.1288	.00664	32.34	.2291	.00657	24.01	.5153	.00648	15.78

* This table does not include the resistances of the stop-cocks and short bends in service pipes. Such resistances, as services are usually laid, reduce the effective delivery of water fully fifty per cent.

In each column of cubic feet per minute, remove the decimal point one place to the left.

TABLE No. 108—(Continued).

FRICITIONAL HEAD IN SERVICE PIPES (in each 100 feet length).

Velocity, in feet per second.	Velocity head, in feet.	1 3/4 IN. DIAMETER.			2 IN. DIAMETER.			3 IN. DIAMETER.			4 IN. DIAMETER.		
		Cubic feet per minute.	Coefficient.	Frictional head.	Cubic feet per minute.	Coefficient.	Frictional head.	Cubic feet per minute.	Coefficient.	Frictional head.	Cubic feet per minute.	Coefficient.	Frictional head.
				<i>Feet.</i>			<i>Feet.</i>			<i>Feet.</i>			<i>Feet.</i>
1.4	.030	1.403	.00800	.668	1.875	.00763	.557	4.123	.00724	.353	7.330	.00697	.255
1.6	.040	1.603	.00786	.857	2.142	.00750	.715	4.712	.00716	.456	8.377	.00690	.342
1.8	.050	1.804	.00769	1.062	2.410	.00741	.895	5.301	.00708	.570	9.424	.00684	.415
2.0	.062	2.004	.00757	1.290	2.678	.00731	1.090	5.891	.00700	.696	10.47	.00678	.505
2.2	.075	2.204	.00745	1.536	2.946	.00724	1.306	6.480	.00693	.833	11.52	.00672	.606
2.4	.090	2.405	.00733	1.799	3.214	.00717	1.539	7.069	.00687	.983	12.56	.00666	.715
2.6	.105	2.605	.00723	2.083	3.481	.00711	1.791	7.685	.00681	1.144	13.61	.00660	.832
2.8	.122	2.806	.00713	2.382	3.794	.00704	2.057	8.247	.00675	1.315	14.66	.00655	.957
3.0	.140	3.006	.00707	2.711	4.018	.00692	2.321	8.846	.00670	1.498	15.71	.00650	1.090
3.2	.160	3.206	.00700	3.054	4.286	.00686	2.618	9.435	.00665	1.692	16.76	.00645	1.231
3.4	.180	3.407	.00694	3.418	4.554	.00681	2.934	10.02	.00661	1.899	17.80	.00641	1.381
3.6	.202	3.607	.00688	3.799	4.821	.00677	3.270	10.61	.00657	2.117	18.85	.00637	1.538
3.8	.225	3.808	.00685	4.215	5.089	.00674	3.623	11.20	.00654	2.347	19.90	.00634	1.706
4.0	.250	4.008	.00682	4.649	5.357	.00671	4.002	11.78	.00651	2.588	20.94	.00631	1.882
4.2	.275	4.208	.00678	5.096	5.625	.00667	4.385	12.37	.00647	2.836	21.99	.00628	2.065
4.4	.302	4.409	.00674	5.560	5.893	.00663	4.784	12.96	.00644	3.098	23.03	.00625	2.255
4.6	.330	4.609	.00670	6.040	6.160	.00660	5.205	13.55	.00641	3.370	24.08	.00623	2.457
4.8	.360	4.810	.00667	6.547	6.428	.00657	5.643	14.14	.00638	3.653	25.13	.00620	2.662
5.0	.390	5.010	.00664	7.079	6.696	.00654	6.094	14.73	.00636	3.951	26.18	.00618	2.880
5.2	.422	5.210	.00661	7.615	6.964	.00651	6.561	15.32	.00633	4.253	27.23	.00615	3.099
5.4	.455	5.411	.00658	8.175	7.232	.00648	7.059	15.91	.00630	4.565	28.27	.00612	3.326
5.6	.490	5.611	.00655	8.751	7.499	.00645	7.527	16.50	.00627	4.886	30.32	.00609	3.559
5.8	.525	5.812	.00652	9.345	7.767	.00642	8.049	17.09	.00624	5.167	30.37	.00607	3.816
6.0	.562	6.012	.00650	9.970	8.035	.00640	8.587	17.67	.00622	5.564	31.41	.00605	4.059
6.2	.600	6.212	.00647	10.59	8.303	.00637	9.126	18.25	.00619	5.912	32.46	.00603	4.320
6.4	.640	6.413	.00645	11.26	8.571	.00635	9.694	18.85	.00616	6.269	33.50	.00601	4.588
6.6	.680	6.613	.00643	11.93	8.838	.00633	10.28	19.44	.00614	6.646	34.55	.00599	4.863
6.8	.722	6.814	.00641	12.63	9.106	.00631	10.88	20.03	.00612	7.032	35.60	.00597	5.145
7.0	.765	7.014	.00639	13.34	9.374	.00629	11.49	20.62	.00610	7.427	36.65	.00595	5.510

CHAPTER XXIII.

CLARIFICATION OF WATER.

516. Rarity of Clear Waters.—A small but favored minority of the American cities have the good fortune to find an abundant supply of water for their domestic purposes, within their reach, that remains in a desirable state of transparency and limpidity.

The origin and character of the impurities that are almost universally found in suspension in large bodies of water, have been already discussed in the chapters devoted to "Impurities of Water" (Chap. VIII), and to "Supplies from Lakes and Rivers" (Chap. IX); so there remains now for investigation only the methods of separating the foreign matters before pointed out.

517. Floating Debris.—The running rivers, that are subject to floods, bring down all manner of floating debris, from the fine meadow grasses to huge tree-trunks, and buildings entire. These are all visible matters, that remain upon the surface of the water, and their separation is accomplished by the most simple mechanical devices.

Coarse and fine racks of iron, and fine screens of woven copper wire are effectual interceptors of such matters and prevent their entrance into artificial water conduits.

518. Mineral Sediments.—Next among the visible sediments may be classed the gravelly pebbles, sand, disintegrated rock, and loam, that the eddy motions continually

toss up from the channel bottom, and the current bears forward.

These are not intercepted by ordinary screens, but are most easily separated from the water by allowing them quickly to deposit themselves, in obedience to the law of gravitation, in a basin where the waters can remain quietly at rest for a time.

When the water is received into large storage reservoirs, it is soon relieved of these heavy sedimentary matters, by deposition ; and a season of quietude, even though but a few hours in duration, is a valuable preparation for succeeding stages of clarification.

Next are more subtle mineral impurities, consisting of the most minute particles of sand and finely comminuted clay, which consume a fortnight or more, while the water is at rest in a confining basin, in their leisurely meanderings toward the bed of the basin.

If these mineral grains are to be removed by subsidence for a public water supply, the subsidence basin must usually be large enough to hold a three-weeks supply, and must be narrow and deep, so the winds will stir up but a comparatively thin surface stratum, and also so the exposed water will not be heated unduly in midsummer.

519. Organic Sediments.—Next are the organic fragments, including the disintegrating seeds, leaves, and stalks of plants, the legs and trunks of insects and crustacea, and the macerated refuse from the mills.

All these have so nearly the same specific gravity as the water, that they remain in suspension until decomposition has removed so much of their volatile natures that the mineral residues can finally gravitate to the bottom.

If these are to be removed by subsidence, the basin must hold several months supply, at least, and be so formed

and protected as to neither generate or receive other impurities.

In addition, are the innumerable throngs of living creatures that people the ponds and streams, and their spawns. These cannot be removed by subsidence during their active existence, and reproduction maintains always their numbers good.

520. Organic Solutions.—Still more subtle than all the above impurities, that remain in *suspension*, are the dissolved organic matters that the water takes into *solution*. These include the dissolved remains of animate creatures, dissolved fertilizers, and dissolved sewage.

All the former may be treated mechanically with tolerable success, but the latter pass through the finest filters and yield only to chemical transformations.

521. Natural Processes of Clarification.—Nature's process for removing all these impurities, to fit the water for the use of animals, is to pass them through the pores of the soil and fissures of the rocks. The soil at once removes the matters in *suspension*, and they become food for the plants that grow upon the soil, and are by the plants reconverted into their original elements. The minerals of the soil reconvert the organic matters in *solution* into other combinations and separate them from the water.

522. Chemical Processes of Clarification.—Artificial chemical processes, more or less successful in their action, have been employed from the remotest ages to separate quickly the fine earthy matters from the waters of running streams. The dwellers on the banks of streams, who had no other water supply, treated them, each for themselves, and in like manner have others treated the rain waters which they caught upon their roofs, when they had no other domestic supplies.

Many centuries ago the Egyptians and Indians had discovered that certain bitter vegetable substances which grew around them were capable of hastening the clarification of the waters of the Nile, Ganges, Indus, and other sedimentary streams of their countries.

The Canadians have long been accustomed to purify rain-water by introducing powdered alum and borax, in the proportions of 3 ounces of each to one barrel ($31\frac{1}{2}$ gals.) of water; and alum is used by dwellers on the banks of the muddy Mississippi to precipitate its clay. Arago observed also the prompt action of alum upon the muddy water of the Seine. One part of a solution of alum in fifty thousand parts of water results in the production of a flocculent precipitate, which carries down the clayey and organic matters in suspension, leaving the water perfectly clear.

Dr. Gunning demonstrated by many experiments that the impure waters of the river Maas, near Rotterdam, could be fully clarified and rendered fit for the domestic supply of the city, by the introduction of .032 gramme of perchloride of iron into one liter of the water. The waters of the Maas are very turbid and contain large proportions of organic matter, and they often produce in those visitors who are not accustomed to their use, diarrhoeas, with other unpleasant symptoms.

Dr. Bischoff, Jr., patented in England, in 1871, a process of removing organic matter from water by using a filter of spongy iron, prepared by heating hydrated oxide of iron with carbon. The water is said to be quite perceptibly impregnated with iron by this process, and a copious precipitate of the hydrated oxide of iron to be afterwards separated.

Horsley's patent process for the purification of water

covers the use of oxalate of potassa, and Clark's the use of caustic lime.

Mr. Spencer has used in England with great success, in connection with sand filtration, the crushed grains of a carbide of iron, prepared by roasting red hematite ore, mixed with an equal part of sawdust, in an iron retort. This he mixes with one of the lower sand strata of a sand filter, and its office is to decompose the organic matters in solution in the water. The carbide is said to perform its office thoroughly several years in succession without renewal. Mr. Spencer's process may be applied on a scale commensurate with the wants of the largest cities, and has been adopted in several of the cities of Great Britain.

Dr. Medlock was requested by the Water Company of Amsterdam to examine the water gathered by them from the *Dunes* near Haarlem, for delivery in the city. The water had a peculiar "fish-like" odor, and after standing awhile, deposited a reddish-brown sediment.

Under the microscope, the deposit was seen to consist of the filaments of decaying algæ, confervæ, and other microscopic plants, of various hues, from green through pale-yellow, orange, red, brown, dark-brown, to black.

The Doctor found the open water channels lined with a luxuriant growth of aquatic plants, and the channel-bed covered with a deposit of black decaying vegetal matter. He discovered also that the reddish-brown sediment was deposited in greatest abundance about the iron sluice-gates. Copper, platinum, and lead, in finely-divided states, were known by him to have the power of converting ammonia into nitrous acid, and he was led to suspect that iron possessed the same power. Experiments with iron in various states, and finally with sheet-iron, demonstrated that strips of iron placed in water containing ammonia, or organic

matter capable of yielding it, acted almost as energetically as the pulverized metal. The organic matters of the Thames water in London, and the Rivington Pike water in Liverpool, as well as the Dune water in Amsterdam, were found to be completely decomposed or thrown down by contact with iron, and the iron acted effectually when introduced into the water in strips of the sheet metal or in coils of wire. This simple and easy use of iron may be employed in subsidence basins or reservoirs on the largest scale for towns, as well as on a smaller scale for a single family.

The results of these experiments with iron were considered of such great hygienic and national importance by Dr. Sheridan Muspratt that he has put an extended account of them on record.*

523. Charcoal Process.—The charcoal plate filters prepared under the patent of Messrs. F. H. Atkins & Co., of London, have not been introduced here as yet, so far as the writer is informed.

The valuable chemical and mechanical properties of animal charcoal for the purification of water have long been recognized, and it was the practice in the construction of the early English filter-beds, as prepared by Mr. Thom, to mix powdered charcoal with the fine sand.

If there is either lime or iron in the water, as there is in most waters, the chemical action results in the formation of an insoluble precipitate upon the grains of charcoal, when they become of no more value than sand, and their action is thenceforth only mechanical. Messrs. Atkins & Co. have devised a method of overcoming this difficulty, in part at least, by forming the charcoal into plates, usually one foot square and three inches thick, and so firm that their coated surfaces can be scraped clean. These plates may be set in

* Muspratt's Chemistry, p. 1085, Vol. II.

FIG. 129.

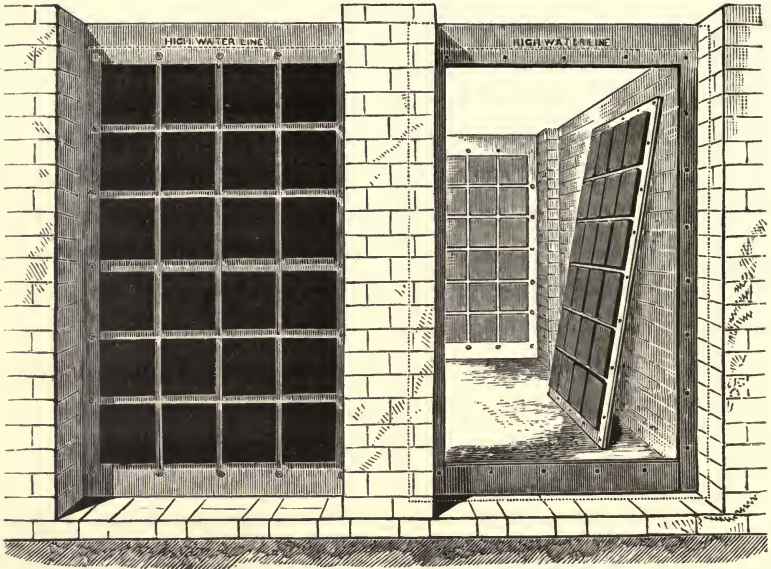

CHARCOAL-PLATE FILTERS.

frames, Fig. 129, as lights of glass are set in a sash, and the water be made to flow through them. They are compounded for either slow or quick filtration; the dense plates (a square foot) passing 30 to 40 imperial gallons per diem, the porous 80 to 100 gallons, and the very porous 250 to 300 gallons per diem, when clean. The water may be first passed through sand, for the removal of the greater part of the organic matters.

The use of charcoal has heretofore been confined almost entirely to the laboratory, so far as relates to the purification of water, and animal charcoal has been found very much superior to wood and peat coals. Its success has undoubtedly been due largely to its intermittent use and frequent cleanings and opportunities for oxidation. Its power of chemical action upon organic matter is very quickly reduced, and it must be often cleaned to be

effectual. Some very interesting and valuable experiments to test the purification powers of charcoal upon foul waters, were described to the members of the Institution of Civil Engineers, by Edward Byrne, in May, 1867.

524. Infiltration.—If any water intended for a domestic supply is found to be charged with organic matter *in solution*, the very best plan of treatment, relating to that water, is to let it alone, and take the required supply from a purer source.

The impurities *in suspension* in water may best be treated on Nature's plan, by which she provides us with the sparkling limpid waters of the springs that bubble at the bases of the hills and from the fissures in the rocks.

525. Infiltration Basins.—In the most simple natural plan of clarification, a well, or basin, or gallery, is excavated in the porous margin of a lake or stream, down to a level below the water surface, where the water supply will be maintained by infiltration.

All those streams that have their sources in the mountains, and that flow through the drift formation, transport in flood large quantities of coarse sand and the lesser gravel pebbles. These are deposited in beds in the convex sides of the river bends, and the finer sands are spread upon them as the floods subside. From these beds may be obtained supplies of water of remarkable clearness and transparency.

The volume of water to be obtained from such sources depends, first, upon the porosity of the sand or gravel between the well, basin, or gallery, and the main body of water, the distance of percolation required, the infiltration area of the well or gallery, and the head of water under which the infiltration is maintained.

A considerable number of American towns and cities have already adopted the infiltration system of clarification

of their public water supplies, and although it is not one that can be universally applied, it should and will meet with favor wherever the local circumstances invite its use. Attention has not as yet become fairly attracted in America to the benefits and the necessities of filtration of domestic water supplies, and many of the young cities have been obliged to make an herculean effort to secure a public water supply, having even the requisite of abundance, and they have been obliged to defer to days of greater financial strength the additional requisite of clarification. A knowledge of the processes of clarification, which are simple for most waters, is being gradually diffused, and this is a sure precursor of the more general acceptance of its benefits.

In some of the small western and middle State towns, the infiltration basins have heretofore taken the form of one or more circular wells, each of as large magnitude as can be economically roofed over, or of narrow open basins. In the eastern States the form has usually been that of a covered gallery along the margin of the stream or lake, or of a broad open basin. Some of these basins are intended quite as much to intercept the flow of water from the land side toward the river as to draw their supplies from the river, and the prevailing temperatures and chemical analyses of the waters, as compared with the temperatures and analyses of the river waters, give evidence that their supplies are in part from the land.

A thorough examination of the substrata, on the site of and in the vicinity of the proposed infiltration basin, down to a level eight or ten feet below the bottom of the basin, will permit an intelligent opinion to be formed of its percolation capacity.

526. Examples of Infiltration.—Fig. 130 illustrates a section of the infiltration gallery at Lowell, Mass. This

gallery is a short distance above the city and above the dam of the Locks and Canal Co. in the Merrimac River, that supplies some 10,000 horse-power to the manufacturers of the city. The gallery is on the northerly shore of the stream, parallel with it, and lies about one hundred feet from the shore.

Its length is 1300 feet, width 8 feet, and clear inside height, 8 feet. Its floor is eight feet below the level of the crest of the dam. The side walls have an average thickness of two and three-fourths feet, and a height of five feet, and are constructed of heavy rubble masonry, laid water-tight in hydraulic mortar.

FIG. 130.

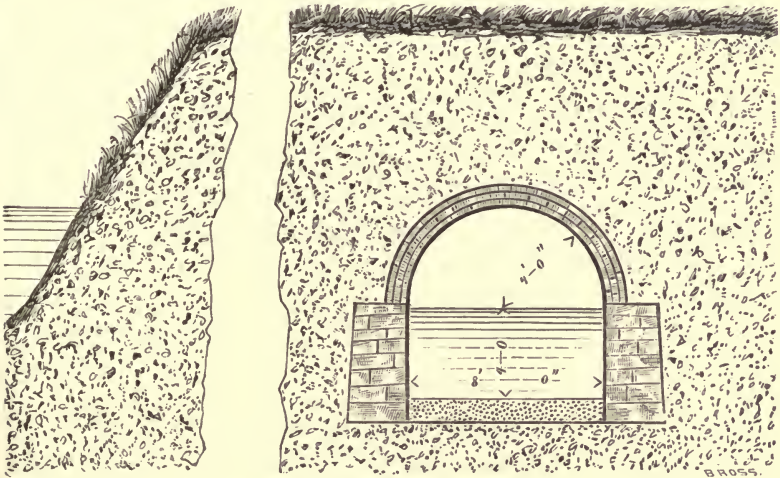

LOWELL INFILTRATION GALLERY.

The covering arch is semicircular, of brick, one foot thick, and is laid water-tight in cement mortar.

Along the bottom, at distances of ten feet between centres, stone braces one foot square and eight feet long, are placed transversely between the side walls to resist the exterior thrust of the earth and the hydrostatic pressure.

The bottom is covered with coarse screened gravel, one foot thick, up to the level of the top of the brace stones.

The required depth of excavation from the surface of the plain averaged about sixteen feet.

The Merrimac River is tolerably clear of visible impurities during a large portion of the year, but during high-water carries a large quantity of clay and of a silicious sand of very minute, microscopic grains.

An inlet pipe, thirty inches in diameter, connects the lower end of the gallery directly with the river, for use in emergencies, and to supplement the supply temporarily at low-water in the river, when it is usually clear. At the terminal chamber of the gallery into which the inlet pipe leads, and from which the conduit leads toward the pumps, are the requisite regulating gates and screens.

This gallery was completed in 1871, and during the drought and low water of the summer of 1873, a test developed the continuous infiltration capacity of the gallery to be one and one-half million gallons per twenty-four hours, or about one hundred and fifty gallons for each square foot of bottom area per twenty-four hours.

At Lawrence, Mass., is a similar infiltration gallery along the eastern shore of the Merrimac River, from which the city's supply is at present drawn.

The infiltration gallery for the supply of the town of Brookline, Mass., completed in 1874, lies near the margin of the Charles River. The bottom is six feet below the lowest stage of water in the river, its breadth between walls four feet, and length seven hundred and sixty-two feet. The side walls are two feet high, laid without mortar, and the covering arch is semicircular, two courses thick, and tight.

During a pump test of thirty-six hours duration, this gallery supplied water at a rate of one and one-half million

gallons in twenty-four hours, or four hundred and ninety gallons per square foot of bottom area per twenty-four hours. The ordinary draught up to the present writing is about one-third this rate.

The pioneer American infiltration basins were constructed for the city of Newark, N. J., under the direction of Mr. Geo. H. Bailey, chief engineer of the Newark water-works. These basins are somewhat more than a mile above the city, on the bank of the Passaic River. There are two basins, each 350 feet long and 150 feet wide, distant about 200 feet from the river. They are revetted with excellent vertical-faced stone walls, and everything pertaining to them is substantial and neat. An inlet pipe connects them with the river for use as exigencies may require.

At Waltham, Mass., a basin was excavated from the margin of the Charles River back to some distance, and then a bank of gravel constructed between it and the river, intended to act as a filter.

The excavation developed a considerable number of springs that flowed up through the bottom of the basin, and these are supposed to furnish a large share of the water supply.

At Providence, two basins have been excavated, one on each side of the Pawtuxet River. These are near the margin of the River, and are partitioned from the floods by artificial gravelly levees.

At Hamilton and Toronto, in Canada, basins have been excavated on the border of Lake Ontario. The Hamilton basin has, at the level of low-water in the lake, a water area of little more than one acre.

At Toronto, the infiltration basin lies along the border of an island in the lake, nearly opposite to the city. It is excavated to a depth of thirteen and one-half feet below

low-water in the lake, has an average bottom width of $26\frac{1}{2}$ feet, side slopes 2 to 1, and length, including an arm of 390 feet, of 3090 feet. This basin is distant about 150 feet from the lake.

The top of the draught conduit, which is four feet diameter, is placed at six and one-half feet below low-water, or the zero datum of the lake; and the water area in the basin, if drawn so low as the top of the conduit, will then be 3.75 acres, and when full to zero line is 5.64 acres, the average surface width being then eighty feet.

During a six days test this basin supplied about four and one-quarter million imperial gallons per twenty-four hours under an average head of five feet from the lake, or at the rate of fifty-two imperial gallons per square foot of bottom area per twenty-four hours.

At Binghamton, N. Y., two wells of thirty feet diameter each, were excavated about 150 feet from the margin of the Susquehanna River, one on each side of the pump-house. These wells are roofed in.

At Schenectady there is a small gallery along the margin of the Mohawk River.

Columbus opened her works with a basin on the bank of the Scioto, and has since added a basin with a process of sand filtration.

Other towns and cities have formed their infiltration basins according to their peculiar local circumstances.

These basins generally clarify the water in a most satisfactory manner, and accomplish all that can be expected of a mechanical process, but they have not always delivered the expected volumes of water; but perhaps too much is sometimes anticipated through ignorance of the true nature of the soil.

527. Practical Considerations.—The experience with

the American and European infiltration basins shows that when judiciously located they should supply from 150 to 200 U. S. gallons per square foot of bottom area in each twenty-four hours continuously. This requires a rate of motion through the gallery inflow surface, of from twenty to twenty-five lineal feet per twenty-four hours.

This inflow is dependent largely upon the area of *shore* surface through which the water tends toward the basin, and the *cleanliness* and *porousness* of that surface.

We have not here the aid of Nature's surface process, in which the intercepted sediment is decomposed by plant action, and the pores thrown open by frost expansions, but are dependent upon floods and littoral currents to clean off the sediment separated from the infiltrating water. If the infiltrating surface is not so cleaned periodically by currents, it becomes clogged with the sediment, and its capability of passing water is greatly reduced.

A uniform sized grain of sand or gravel offers greater percolating facilities than mixed coarse and fine grains. The proportion of interstices in uniform grains is from thirty to thirty-three per cent. of the bulk, and the larger the grains the larger the interstices and the more free the flow. On the other hand, the smaller the grains, or the more the admixture of smaller with predominating grains, the smaller the interstices, and the less the flow, but the more thorough the clarification and the sooner the pores are silted with sediment.

If there is much fine material mixed with the gravel, water will percolate very slowly, and a larger proportional infiltration area will be required to deliver a given volume of water.

It will be remembered that we found gravel (§ 351) with due admixtures of graded fine materials to make the very

best embankment to retain water, even under fifty or more feet head.

The best bank in which to locate an infiltration basin is one which is made up of uniform silicious sand grains of about the size used for hydraulic mortar, and which has a thin covering of finer grains next the body of water to be filtered. The silting will in such case be chiefly in the surface layer, and the cleaning by flood current then be most effectual.

The distance of the basin from the body of water is governed by the nature of the materials, being greater in coarse gravel than in sand. It should be only just sufficient to insure thorough clarification when the surface is cleanest. A greater distance necessitates a greater expense for greater basin area to accomplish a given duty, and a lesser distance will not always give thorough clarification.

The distance should be graduated in a varying stratum, so that the work per unit of area shall be as uniform as possible.

528. Examples of European Infiltration.—Mr. Jas. P. Kirkwood, C. E., in his report* to the Board of Water Commissioners of St. Louis, by whom he was commissioned to examine the filtering processes practised in Europe, as applied to public water supplies, has given most accurate and valuable information, which those who are interested in the subject of filtration will do well to consult.

From Mr. Kirkwood's elaborate report we have condensed some data relating to European infiltration galleries.

Perth, in Scotland, has a covered gallery located in an island in the River Tay. Its inside width is 4 feet, height 8 feet, and length 300 feet. Its floor is $2\frac{1}{2}$ feet below low-water surface in the river. Its capacity is 200,000 gallons

* Filtration of River Waters, Van Nostrand, New York, 1869.

per diem, and rate of infiltration per square foot of bottom area, 182 gallons per diem.

Angers, in France, has a covered gallery located in an island in the River Loire. This gallery has two angles of slight deflection, dividing it into three sections. The two end sections are 3'-4" wide and the centre section 6'-0" wide. The floors of the two end sections are $7\frac{1}{2}$ below low-water in the river, and of the central section $9\frac{1}{2}$ feet below. The combined length of these galleries is 288 feet, and their delivery 187 gallons per diem per square foot of bottom area.

These were constructed in 1856, and rest on a clayey substratum; consequently the greater part of their inflow must be through the open side walls.

More recently, these have been reinforced by a new gallery, with its floor $5\frac{1}{2}$ feet below low-water surface in the river, and not extending down to the clay stratum. This is 5 feet wide and 8 feet high, and delivers 300 gallons per diem per square foot of bottom area.

Lyons, in France, has two covered galleries along the banks of the Rhone, the first 16'-6" wide and 394 feet long. The second is 33 feet wide, except at a short section in the centre, where it is narrowed to 8 feet, and is 328 feet long. There are also two rectangular covered basins. The combined bottom areas of the two galleries is 17,200 square feet, and of the two basins 40,506 square feet. The total delivery at the lowest stage of the river is nearly six million gallons per diem, or 100 gallons per square foot of bottom area. The capacity of the 33-foot gallery alone is, however, 147 gallons per square foot of bottom area. About $6\frac{1}{2}$ feet head is required for the delivery of the maximum quantity. The average distance of the galleries from the river is about 80 feet, and the two basins are behind one of the galleries.

At Toulouse, France, three covered galleries extend along the bank of the Garonne. The first two, after being walled, were filled with small stones.

The new gallery has its side-walls laid in mortar, is covered with a semicircular arch, is 7'-6" wide, 8'-8" high, and 1180 feet long. Its floor is 8'-7" below low-water surface in the river. Its total capacity is a little in excess of $2\frac{1}{2}$ million gallons, or 228 gallons per diem, per square foot of bottom area.

For the supply of Genoa, in Italy, which lies upon the Mediterranean, a gallery has been constructed, in a valley of a northern slope of the Maritime Alps, at an altitude of 1181 feet above the sea. This gallery extends in part beneath the bed of the River Scrivia, transversely from side to side, and in part along the banks of the stream. The width is 5 feet, height 7 to 8 feet, and length 1780 feet.

The extraordinarily large delivery, per *lineal* foot, is 6412 gallons per diem.

The waters are conveyed down to Genoa in cast-iron pipes, with relieving-tanks at intervals.

529. Example of Intercepting Well.—The great well in Prospect Park, Brooklyn, L. I., is a notable instance of intercepting basin, such as is sometimes adopted to intercept the flow of the land waters toward a great valley, or the sea, or to gather the rainfall upon a great area of sandy plain.

This portion of Long Island is a vast bed of sand, which receives into its interstices a large percentage of the rainfall. The rain-water then percolates through the sand in steady flow toward the ocean. Although the surface of the land has considerable undulation, the subterranean saturation is found to take nearly a true plane of inclination toward the sea, and this inclination is found by measurements in

numerous wells to be at the rate of about one foot in 770 ft., or seven feet per mile. So if a well is to be dug at one-half mile from the ocean beach, water is expected to be found at a level about three and one-half feet above mean tide; or, if one mile from the beach, at seven feet above mean tide, whatever may be the elevation of the land surface. If in such subsoils a well is excavated, and a great draught of water is pumped, the surface of saturation will take its inclination toward the well, and the area of the watershed of the well will extend as the water surface in the well is lowered. If the well has its water surface lowered so as to draw toward it say a share equal to twenty-four inches of the annual rainfall on a circle around it of one-quarter mile radius, then its yield should be at the rate of very nearly one-half million gallons of water daily.

The Prospect Park well, Fig. 131 (p. 102), is 50 ft. in diameter. A brick steen or curb of this diameter, resting upon and bolted to a timber shoe, edged with iron, was sunk by excavating within and beneath it, fifty-nine feet to the saturation plane, and then a like curb of thirty-five feet diameter was sunk to a further depth of ten feet. The top of the inner curb was finished at the line of water surface. A platform was then constructed a few feet above the water surface, within the large curb, to receive the pumping engine. The boilers were placed in an ornate boiler-house near the well.

On test trial, the well was found to yield, after the water surface in the well had been drawn down four and one-half feet, at the rate of 850,000 gallons per twenty-four hours.

530. Filter-beds.—A method of filtration, more artificial than those above described, must in many cases be resorted to for the clarification of public water supplies.

The most simple of the methods that has had thorough

FIG. 132.

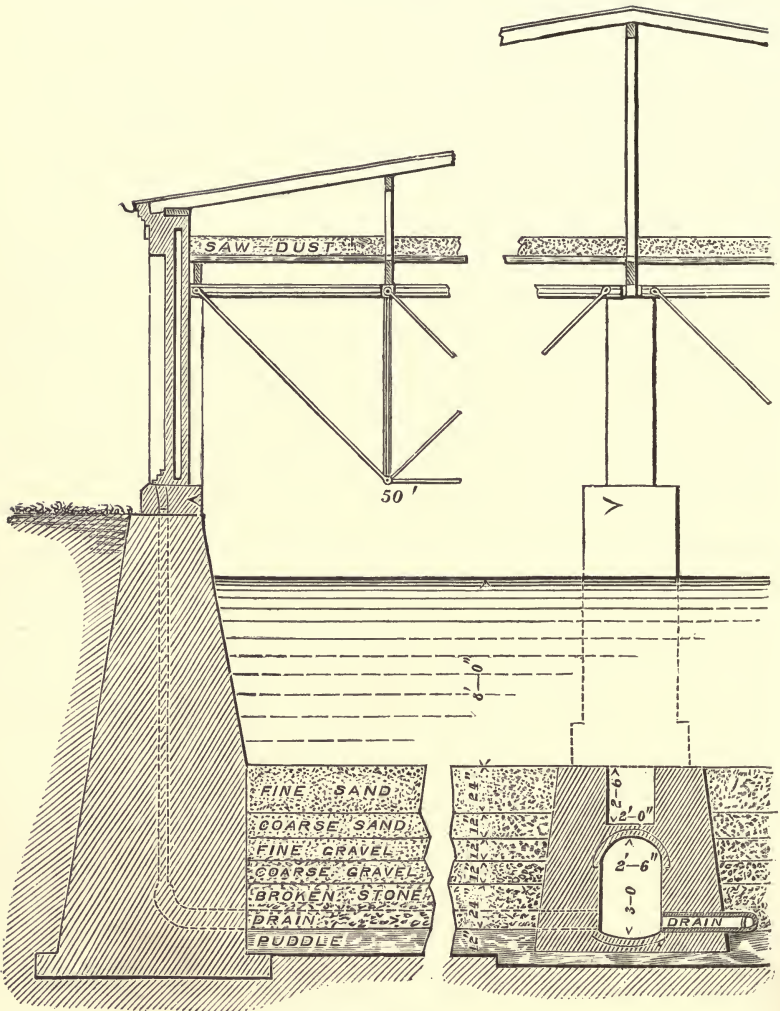

trial, consists in passing the water downward, in an artificial basin specially constructed for the purpose, through layers of fine sand, coarse sand, fine gravel, coarse gravel, and broken stone, to collecting drains placed beneath the whole, Fig. 132.

The basins in such cases are usually from 100 to 200 feet wide, and from 200 to 300 feet long, each. Each basin is made quite water-tight, the horizontal bottom or floor being puddled, if necessary, and sometimes also covered with a paving of concrete, or layer of bricks in cement mortar. The sides are revetted with masonry, or have slopes paved with substantial stone in mortar, or with concrete.

A main drain extends longitudinally through the centre of the basin, rests upon the floor, and is about two feet wide and three feet high. From the main drain, on each side, at right-angles, and at distances of about six feet between centres, branch the small drains. These are six or eight inches in diameter, of porous, or, more generally, perforated clay tiles, resting upon the bottom or floor, and they extend from the central drain to the side walls, where they have vertical, open-topped, ventilating, or air-escape pipes, rising to the top of the side walls.

These pipes and the central drain form an arterial system by which water may be gathered uniformly from the whole area of the basin.

This arterial system is then covered, in horizontal layers, according to the suitable materials available, substantially as follows, viz.: two feet of broken stone, like "road metal;" one foot of shingle or coarse-screened gravel; one foot of pea-sized screened gravel; one foot of coarse sand; and a top covering of one and one-half to three feet of fine sand.

This combination is termed a *filter-bed*, and over it is flowed the water to be clarified.

Provision is made for flowing on the water so as not to disturb the fine sand surface. This inflow duct is often arranged in the form of a tight channel on the top of the

covering of the central gathering drain, and the water flows over its side walls, during the filling of the basin, to right and left, with slow motion.

The depth of water maintained upon the filter-bed is four feet or more, according to exposure and climatic effects upon it.

At the outflow end of the central gathering drain is an effluent chamber, with a regulating gate over which the filtered water flows into the conduit leading to the clear-water basin. The water in the effluent chamber is connected with the water upon the filter-bed through the drains and interstices of the bed ; consequently, if there is no draught, its surface has the same level as that upon the bed, but if there is draught, the surface in the chamber is lowest, and the difference of level is the head under which water flows through the filter-bed to the effluent chamber.

The regulating gate in the effluent chamber controls the outflow there to the clarified water basin, and consequently the head under which filtration takes place, and the rate of flow through the filter-bed.

531. Settling and Clear-water Basins.—When the water is received from a river subject to the roil of floods, it should be received first into a *settling basin*, where it will be at rest forty-eight hours or more, so that as much as possible of the sediment may be separated by the gravity process, before alluded to. Its rest in large storage basins prepares it very fully for introduction to the filter-bed, which is to complete the separation of the microscopic plants, vegetable fibres, and animate organisms, that cannot be separated by precipitation.

Since the domestic consumption of the water at some hours of the day is nearly or quite double the average consumption per diem, the clarified water basin should be

large enough to supply the irregular draught and permit the flow through the filter to be uniform.

This system of clarification in perfection includes three divisions, viz. : the *Settling Basin*, the *Filter-bed*, and the *Clear-water Basin*.

The settling and clear-water basins may be constructed according to the methods and principles already discussed for distributing reservoirs (Chap. XVI). The capacity of each should be sufficient to hold not less than two days supply, and the depth of water should be not less than ten feet, so that the water may not be raised to too high a temperature in summer, and that its temperature may be raised somewhat in winter before it enters the distribution-pipes.

532. Introduction of Filter-bed System.—Poughkeepsie, on the Hudson, was the first American city to adopt the *filter-bed* system of clarification of her public water-supply.

The Poughkeepsie works were constructed in 1871, to take water from the Hudson River. During the spring floods, the river is quite turbid. These filtering works consist of a small settling basin and two filter-beds, each $73\frac{1}{2}$ ft. wide and 200 ft. long. Each bed is composed of

24	inches	of fine sand.
6	"	" $\frac{1}{4}$ -inch gravel.
6	"	" $\frac{1}{2}$ -inch gravel.
6	"	" 1-inch broken stone.
<u>24</u>	"	" 4 to 8-inch spalls.
72	"	total.

The floors on which the beds rest are of concrete, twelve inches thick.

The clear-water basin is 28 by 88 feet in plan, and 17 ft. deep.



Water is lifted from the river to the settling basin by a pump, and it flows from the clear-water basin to the suction chamber of the main pump, giving some back pressure. From thence it is pumped to the distributing reservoir.

The filter-beds are at present used but a portion of the year, subsidence in the main reservoir being sufficient to render the water acceptable to the consumers.

In the recent construction of the new water supply for the city of Toledo, 20,000 square feet of filter-bed was at first prepared to test its efficiency in the clarification of the turbid Maumee River water. The great demand for water has, however, made the construction of additional filter area and large subsidence basins a necessity, the consumption having already (1876) reached nearly 3,000,000 gallons per diem. Anticipating the necessity, Chief Engineer Cook has devised and is experimenting with a series of chambers, to contain filtering materials through which the water is to be flowed with an upward current.

When our American water consumers are more familiar with this filter-bed system of clarification, now in such general use in England and Scotland and on the Continent, its use will be oftener demanded. Subsidence, as we have before remarked, does not completely clarify the water, even in a fortnight's or three weeks' time, but a good sand filter, if not overworked, intercepts not only the visible sediment and fine clay, but the most minute vegetable fibres and organisms and the spawn of fish, and it is highly important that these should be separated before the water is passed to the consumer.

533. Capacity of Filter-Beds.—Experience indicates that the flow through a filter-bed, such as we have above described, should not exceed the rate of 17 feet lineal per diem, or be reduced by silting of the sand layer to less than

6.5 feet per diem. It must not be so rapid as to suck the sand grains or clay particles or the intercepted fibres through the bed, or its whole purpose will be entirely defeated.

A rate of about one-half inch per hour, or twelve lineal feet per diem, when the filter is tolerably clean, is generally considered the best. This gives the filter-bed a capacity of twelve cubic feet, or 89.76 gallons, per square foot of surface per twenty-four hours, and requires, in work, about 12,000 square feet of filtering surface for each million gallons of water to be filtered per diem.

534. Cleaning of Filter-Beds.—The filter-beds upon the English streams require cleaning about once a week, when the rivers are in their most turbid condition, and ordinarily once in three or four weeks.

The process of cleaning consists of removing a slice of about one-half inch thickness from the surface of the fine sand layer, and the stirring or loosening up of the sand that is packed hard by the weight of the water, when the clogging of the filter prevents or hinders greatly its flow. This requires the water to be drawn off from the bed to be cleaned, and of course puts the portion of filter area being cleaned out of service. According to the usual practice, the water is drawn down only about a foot below the sand surface for the cleaning; but there is a great advantage, though an inconvenience, in drawing the water entirely out of the bed, for this admits the air to oxidize the organic matters that are drawn into the filter, which is of great importance.

To provide for cleaning, the required area for service should be divided into two or more independent beds, and then one additional bed should be provided also, so that there shall always be one bed surplus that may be put out of use for cleaning.

The greater the number of equal divisions the less will be the surplus area to be provided, and on the other hand, each division adds something to the cost, so that both convenience and finance are factors controlling the design as well as the form and extent of lands available.

As a suggestion merely, it is remarked that the divisions may be approximately as follows, for given volumes, dependent on the turbidness of water and local circumstances :

TABLE No. 109.

DIMENSIONS OF FILTER-BEDS FOR GIVEN VOLUMES.

For	1	million	gallons	per	diem,	3	beds	60	feet	×	100	feet.
"	2	"	"	"	"	3	"	80	"	×	150	"
"	3	"	"	"	"	3	"	100	"	×	180	"
"	4½	"	"	"	"	4	"	100	"	×	180	"
"	6	"	"	"	"	4	"	100	"	×	240	"
"	8	"	"	"	"	4	"	120	"	×	270	"
"	10	"	"	"	"	5	"	120	"	×	270	"

535. Renewal of Sand Surface.—When the repeated pairings from the surface have reduced the top fine-sand layer to about twelve inches thickness, a new coat should be put on restoring it to its original thickness.

If good fine sand is difficult of procurement, the pairings may perhaps be washed for replacing with economical result.

This is sometimes accomplished by letting water flow over the sand in an inclined trough of plank, having cleats across it to intercept the sand, or by letting water flow up through it in a wood or iron tank. In the latter case water is admitted under pressure through the bottom of the tank, and the sand rests upon a grating covered with a fine wire cloth, placed a short distance above the bottom of the tank. The current is allowed to flow up through the sand and over the top of the tank until it runs clear.

536. Basin Coverings.—The British and Continental filter-beds are rarely roofed in, although the practice is almost universal of vaulting over the distributing reservoirs that are near the towns.

The intensity of our summer heat and intensity of winter cold in our northern and eastern States, makes the roofing in of our filter-beds almost a necessity, though we are not aware that this has been done as yet in any instance.

The use of the shallow depth of four feet of water, so common in the English filters, would be most fatal to open filters here, for the water would frequently be raised in summer to temperatures above 80° Fah. and sent into the pipes altogether too warm, with scarce any beneficial change before it reached the consumer. Such temperatures induce also a prolific growth of *algæ* upon the sides of the basin, and upon the sand surface when it has become partially clogged, and soon produce a vegetable scum upon the water surface also. As these vegetations are rapidly reproduced and are short-lived, their gases of decomposition permeate the whole flow, and render the water obnoxious.

Depth of water and protection from the direct heating action of the sun are the remedies and preventatives for such troubles. A free circulation of air and light must, however, be provided, and also the most convenient facilities for the cleansing and renewal of the bed.

In Fig. 132 is presented a suggestion for a roof-covering that will give the necessary protection from sun and frost, and the requisite light, ventilation, and convenience of access.

The side walls are here proposed to be of brick, and the truss supporting the roof to be of the suspended trapezoidal class. The confined air in the hollow walls, and the saw-dust or tan layer over the truss, are the non-conductors that

assist in maintaining an even temperature within the basin, and resist the effects of intense heat and intense cold.

The Parisian reservoirs at Ménilmontant, and the splendid new structure at Moutrouge, are covered with a system of vaulting, after the manner practised by the Romans, and this system is also followed by the British engineers in their basin covers.

A substantial cover over a filter basin will reduce the difficulties with ice to a minimum, and remove the risk of the bed being frozen while the water is drawn off for cleaning in winter. In such case, if the water is drawn immediately from a deep natural lake, or a large impounding reservoir, the only ice formation will be a mere skimming over of the surface in the severest weather, and the inflow of water, at a temperature slightly above freezing, will tend constantly to preserve the surface of the water uncongealed, and the sand free from anchor ice.

FIG. 133.

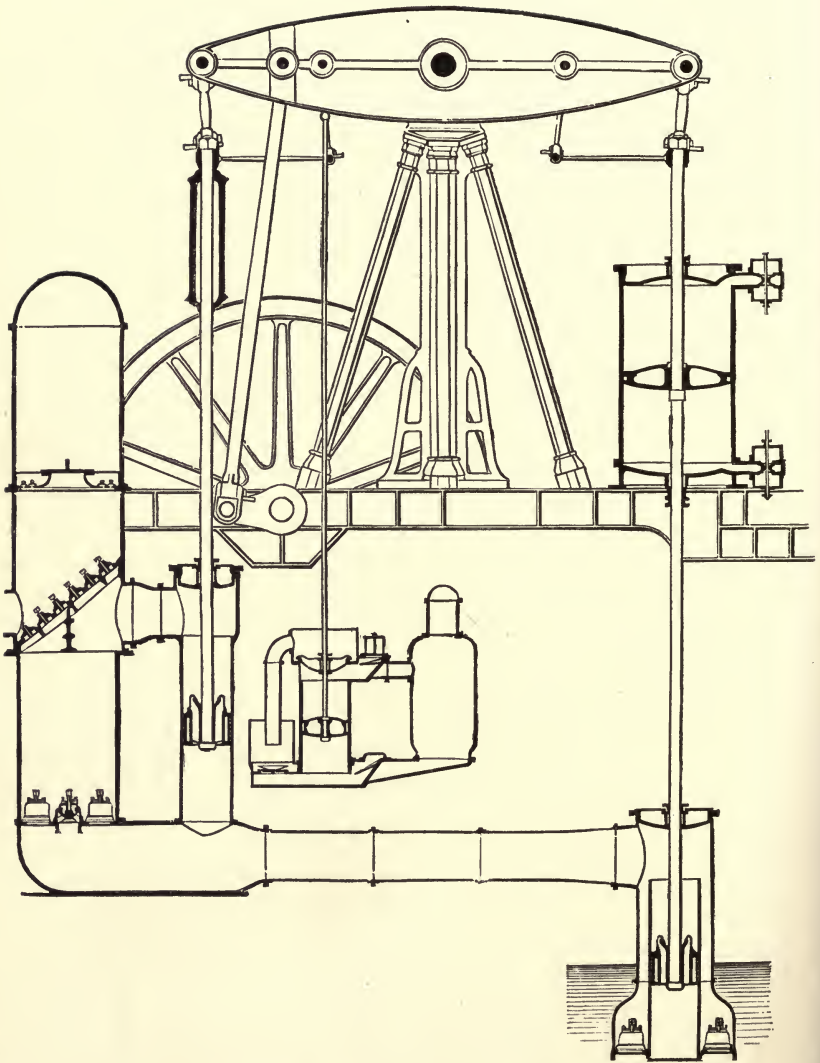

PUMPING ENGINE No. 3, BROOKLYN.

CHAPTER XXIV.

PUMPING OF WATER.

537. Types of Pumps.—The machines that have been used for raising water for public water supplies in the United States present a variety of combinations, but their water ends may be classified and illustrated by a few type forms.

Our space will not permit a discussion of the theories and details of their prime movers, nor more than a general discussion of the details of the pumps, with their relations to the flow of water in their force mains.

The horizontal double-acting piston pump of the type, Fig. 134, is an ancient device, and in its present form remains substantially as devised by La Hire, and described in the Memoirs of the French Academy in 1716. This was at one time a favorite type, and was adopted for the most prominent of the early American pumping works, as at Philadelphia, Richmond, New Haven, Cincinnati, Montreal, etc.

Several modifications of the vertical plunger pump, after the modern Cornish pattern (Fig. 135), were later introduced at Jersey City, Cleveland, Philadelphia, Louisville, etc., and in 1875 at Providence.

The vertical bucket pump (Fig. 133), in various modifications (referring to the water end only), was introduced at Hartford, Brooklyn, New Bedford, etc.

The bucket-plunger pump (Fig. 136, water end), has been more recently introduced at Chicago, St. Louis, Milwaukee, Lowell, Lynn, Lawrence, Manchester, etc.

A vertical acting differential plunger pump, having one set of suction and one set of delivery valves, each arranged in an annular ring around the plunger chamber, has recently been invented by at least two engineers, independently of each other, and with similar disposition of parts. This, like the bucket and plunger pump, is single-acting in suction and double-acting in delivery. This pump gives promise of superior excellence

The double-acting horizontal plunger pump (page 223), itself an ancient and admirable invention, was first introduced in combination with the Worthington duplex engine about the year 1860, and has since been adopted at Harrisburg, Charlestown, Newark, Salem, Baltimore, Toledo, Toronto, Montreal, etc.

FIG. 134.

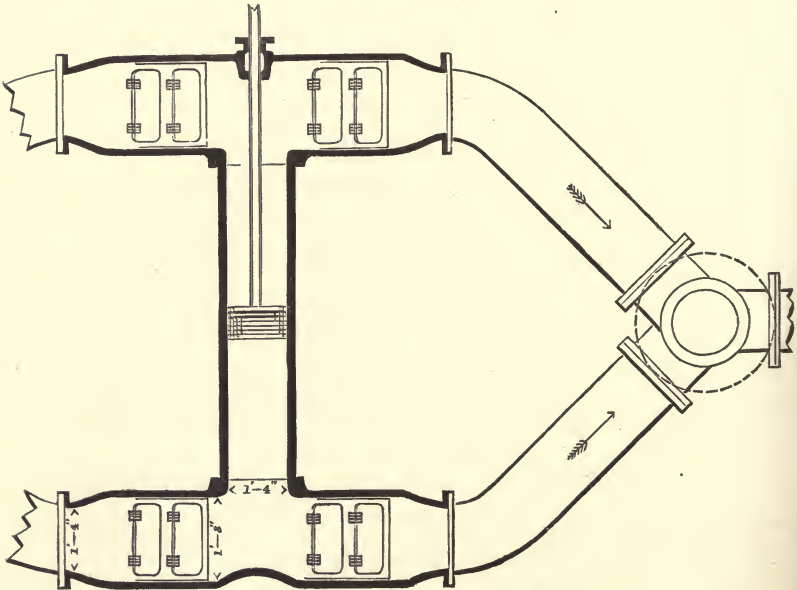

HORIZONTAL DOUBLE-ACTING PISTON PUMP.

Rotary, and gangs of small piston pumps have been introduced to some extent, in direct pressure systems, in some of the small Western towns.

538. Several of the earliest pumps* of magnitude worthy of note were driven by overshot, or breast water-wheels, as at Bethlehem, Pa., Fairmount Works, Philadelphia, New Haven, Richmond, and Montreal. Turbines have, however, taken the places of the horizontal wheels at Philadelphia and Richmond, and in part at Montreal, and turbines give the motion at Manchester, Lancaster, Bangor, and at other cities.

Fig. 143 shows the latest improved form of the Geyelin-Jonval turbine, which has been used very successfully in several of the large cities for driving pumps.

The greater number of the pumping machines now in use are actuated by compound steam-engines.

A considerable number of the large pumping machines have their pump cylinders in line with their steam cylinders, and their pump rods in prolongation of their steam piston rods.

539. Expense of Variable Delivery of Water.—It is important that the delivery of water into the force-main from the pumping machinery be as *uniform* as possible, and constant.

If the delivery of water is intermittent or variable, and the flow in the main equally variable, then power is consumed at each stroke in accelerating the flow from the minimum to the maximum rate.

The *vis viva*† of the column of water in the force-main, surrendered during the retardation at each stroke, is neutral-

* Bethlehem, Pa., constructed in 1762 the first public water supply in the United States in which the pumps were driven by water-power. Philadelphia constructed, in 1797, on the Schuylkill River, a little below Fairmount, the first public water-works in the United States driven by steam-power. In 1812 steam-pumps were started at Fairmount, and the old works abandoned. In April, 1822, the hydraulic-power pumps were started at Fairmount.

† *Vide* "principle of *vis viva*," in Moseley's "Mechanics of Engineering," p. 115, New York, 1860, and Poncelet's *Mécanique Industrielle*, Art. 135, Paris, 1841.

ized by gravity, and no useful effect or aid to the piston of the pump is given back, as useful work is given during the retardation of the fly-wheel of an engine.

If, as when the pump is single-acting, motion is generated during each forward stroke, and the column comes to rest during the return stroke of the piston, or between strokes of the piston, the power consumed (neglecting friction) to generate the maximum rate of motion, equals the product of the weight of the column of water into the height to which such maximum rate of motion would be due if the column was falling freely, in vacuo, in obedience to the influence of gravity.

Let Q be the volume of water to be set in motion, in cubic feet, w the weight of a cubic foot of water, in pounds ($= 62.5$ lbs), h_1 the equivalent height, in feet, to which the rate of motion is due ($= \frac{v^2}{2g}$), and p_1 the power required to produce the acceleration; then

$$p_1 = Q \times w \times h_1. \quad (1)$$

If the velocity is checked and then accelerated during each stroke, without coming to a rest, let v be the maximum velocity, in feet per second, and v_1 the minimum velocity; then the power consumed in or necessary to produce the acceleration is

$$p_1 = Q \times w \times \left\{ \frac{v^2}{2g} - \frac{v_1^2}{2g} \right\}. \quad (2)$$

In illustration of this last equation, which represents a smaller loss than the first, assume the force-main, with air-vessel inoperative, to be 1000 feet long and 2 feet diameter, and the maximum and minimum velocities of flow to be 5 feet and 4 feet per second respectively.

The weight of the contents of the main into its acceleration will be $(.7854d^2 \times l) \times w \times \left\{ \frac{v^2}{2g} - \frac{v_1^2}{2g} \right\} = 3142$ cu. ft. \times

62.5 lbs. \times .14 ft. = 27492.5 foot-lbs. If there are ten strokes per minute, 274925 foot lbs. = $8\frac{1}{2}$ HP will be thus consumed. If the main is twice, or four times as long, the power consumed will be doubled, or quadrupled.

The power required to accelerate the motion of the column is in addition to the dynamic power P_1 in foot-lbs., required to lift it through the height H , of actual lift.

For the equation of lifting power per second, when Q is the volume per second (neglecting friction), we have

$$P_1 = Q \times w \times H, \quad (3)$$

or for any time,

$$P_1 = Q \times t \times w \times H. \quad (4)$$

The frictional resistance to flow in a straight main is proportional, very nearly to the square of the velocity of flow (to mv^2), and is computed by some formula for frictional head h'' , among which for lengths exceeding 1000 feet is

$$h'' = \frac{4lmv^2}{2gd}, \quad (5)$$

in which h'' is the vertical height, in feet, equivalent to the frictional resistance.

l " length of main, in feet.

d " diameter of the main, in feet.

m is a coefficient, which may be selected from Table 61, page 242, of values of m .

The equation of power p'' , to overcome the frictional head, is

$$p'' = Q \times w \times \frac{4lmv^2}{2gd}. \quad (6)$$

The equation of power required, expressed in horse-powers [$H.P.$] of 33,000 foot-pounds per minute, each, for dynamic lift, and frictional resistance to flow combined, is

$$[H.P.] = \frac{Q \times t \times w \times (H + h'')}{33,000}. \quad (7)$$

The several resistances above described are all loads upon the pump-piston, and their sum, together with the frictions at angles and contractions, is the load, *from the flow in the main* which the prime mover has to overcome.

When the delivery of the water into the main is constant and uniform, these resistances are at their minimum.

540. Variable Motions of a Piston.—If we analyze the rates of motion during the forward stroke of a piston moved by a revolving crank with uniform motion, whose length or radius of circle is 1 foot, we find the spaces or distances moved through in equal times by the piston, while the crank-pin passes through equal arcs, to be as in the following table.

TABLE N O. 110.

PISTON SPACES, FOR EQUAL SUCCESSIVE ARCS OF CRANK MOTION, $11\frac{1}{4}^{\circ}$.

Arcs.....	0°	$11\frac{1}{4}^{\circ}$	$22\frac{1}{2}^{\circ}$	$33\frac{3}{4}^{\circ}$	45°	$56\frac{1}{4}^{\circ}$	$67\frac{1}{2}^{\circ}$	$78\frac{3}{4}^{\circ}$	90°
Space, ft..	0	.0223	.0648	.1034	.1384	.1655	.1849	.1946	.1981
Arcs.....	$101\frac{1}{4}^{\circ}$	$112\frac{1}{2}^{\circ}$	$123\frac{3}{4}^{\circ}$	135°	$146\frac{1}{4}^{\circ}$	$157\frac{1}{2}^{\circ}$	$168\frac{3}{4}^{\circ}$	180°
Space, ft..	.1921	.1806	.1609	.1375	.1104	.0814	.0488	.0163

The spaces are equal to the above, but in inverse order during the return stroke. To compute spaces for other lengths of crank, and the same arcs, multiply the given lengths of crank in feet by the above spaces.

The sum of the motions of the piston while the pin moves through the first 90° is 1.072 feet, and while through the second 90° is .928 feet; therefore the motion of the piston is faster during the first and fourth parts of the revolution than during the second and third.

The motion of the piston is accelerated through .5218 of its forward and .4782 of its return stroke, and is retarded during the remaining parts of its forward and backward

FIG. 135.

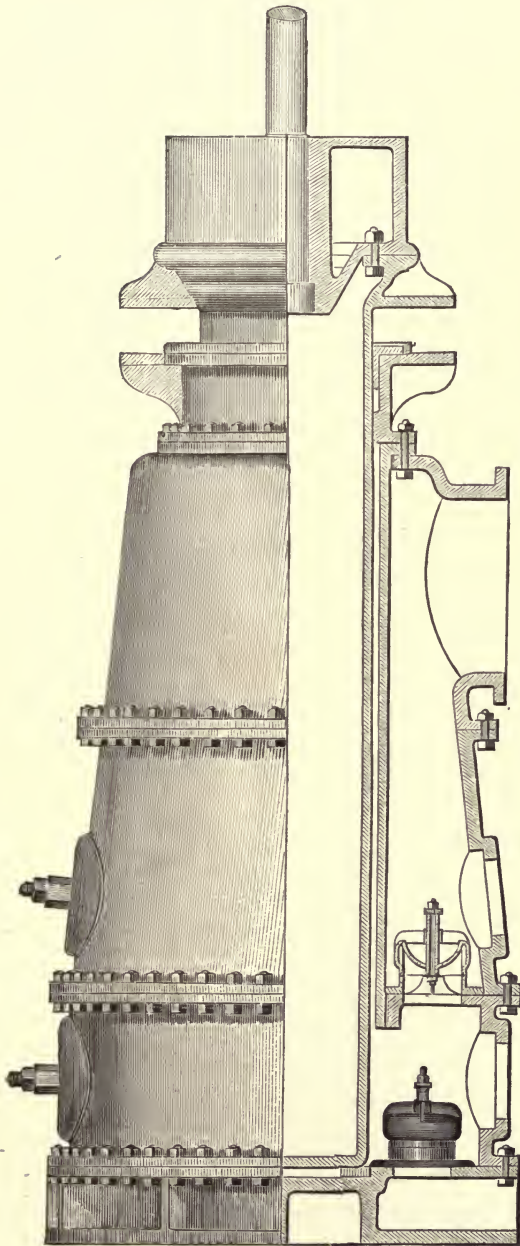

CORNISH PUMP, JERSEY CITY.

motions; and with the usual length of connecting rod, it attains a maximum velocity equal to about 1.625 times its mean velocity.

If the pump is single acting, then no delivery of water takes place during the return stroke, and this is the most difficult case of intermittent motion to provide for in the main.

541. Ratios of Variable Delivery of Water.—If we analyze the ratios of movement of a single, and the sums of ratios of movement of two or three coupled double-acting pump pistons, when the two crank-pins are 90° apart, and the three pins 60° , we find the ratios, during the forward motion of piston No. 1, for given arcs, approximately as in the following table:

TABLE NO. 111.

RATIOS, AND SUMS OF RATIOS, OF PISTON MOTIONS FOR EQUAL SUCCESSIVE ARCS OF CRANK MOTION, $11\frac{1}{4}^\circ$.

Arcs.....	0	$11\frac{1}{4}$	$22\frac{1}{2}$	$33\frac{3}{4}$	45	$56\frac{1}{4}$	$67\frac{1}{2}$	$78\frac{3}{4}$	90
1 piston..	.0	.0423	.0840	.1180	.1490	.1653	.1906	.1967	.1953
2 pistons.....	.1629	.2293	.2550	.2697	.2753	.2730	.2567	.2366	.1960
3 pistons.....	.3426	.3700	.3866	.3896	.3776	.3577	.3640	.3853	.3930

Arcs.....	$101\frac{1}{4}$	$112\frac{1}{2}$	$123\frac{3}{4}$	135	$146\frac{1}{4}$	$157\frac{1}{2}$	$168\frac{3}{4}$	180	
1 piston.....	.1853	.1710	.1500	.1250	.0967	.0660	.0333	.0
2 pistons.....	.2293	.2546	.2680	.2730	.2730	.2610	.2310	.1960
3 pistons.....	.3810	.3613	.3200	.3777	.3893	.3856	.3700	.3740

The variations of motion, and of *delivery of water*, on each side of the *mean* rate of delivery is with one piston about 10 per cent., with two pistons about $5\frac{1}{2}$ per cent., and with three pistons about $2\frac{1}{2}$ per cent., or in other words, the ratios of excess of delivery are .10, .055, .025, and the ratios of deficiency have like values.

542. Office of Stand-Pipe and Air-Vessel.—It is the office of the stand-pipe and air-vessel to take up the

excess, and to compensate for the deficiency of delivery by the pump pistons, plungers, or buckets. These are most effective when nearest to the pump cylinders.

The excess of delivery enters the open-topped stand-pipe and raises its column of water, and the column is drawn from and falls to supply the deficiency. Work is expended to lift the column, and this work is given to the advancing water in the main when the column falls again, but when the piston is again accelerated it has the labor of checking the motion of the falling column in the stand-pipe.

The air-vessel on the force main is practically a shorter, closed-top stand-pipe containing an imprisoned body of air. The excess of delivery of water from the pumps enters the air-vessel and compresses the air, and the expansion of the air forces out water to supply the deficiency. The reduction at each stroke of the mean volume of the air in the vessel is directly proportioned to the excess of water delivered and received into the air-vessel, which is; for different pumps, proportional to their variations, or if coupled or working through the same air-vessel, to the algebraical sums of their variations.

543. Capacities of Air-Vessels.—The cubical capacity of an air-vessel for one pair of double-acting pumps is usually about five or six times the combined cubical capacity of the water cylinders; but we shall see that the capacity of the cylinders alone is not the full basis on which the capacity of the vessel is to be proportioned.

If the air-vessel is filled with air under the pressure of the atmosphere only, and then is subjected to a greater pressure of water, it will not remain full of air, for the air will be compressed, and, according to Mariotte's law,* its

* *Vide* Lardner's Hydrostatics and Pneumatics, p. 158. London, 1874.

volume will be inversely proportional to the pressure under which it exists, provided the temperature remains the same. Thus, if the vessel was filled under a pressure of 15 lbs. per square inch, and the water pressure is six times greater or 90 lbs. per square inch, and the temperature is unchanged, then the air-vessel will be but one-sixth full.

It is the reduced volume of air in the vessel that is compressed to take up the excess of water delivered by the pumps; therefore the *degree of pressure* should be a factor in the equation of capacity of air-vessel, as well as the *ratio of excess of delivery* during a half stroke.

Let q be the volume of delivery of a pump piston during its forward stroke, r the ratio of excess; or if two or more pistons are coupled, the algebraic sum of ratios of excess of delivery of water during the forward stroke of No. 1 piston, n the maximum pressure of water in atmospheres (= 14.7 lbs. per square inch each), and f an experience coefficient whose value will ordinarily be about 15, then the equation for cubical capacity, C , in cubic feet, of air-vessel is,

$$C = q \times r \times n \times f, \quad (8)$$

or if p is the maximum water pressure, in pounds per square inch, then the equation, when $f = 15$, may take the form

$$C = pqr. \quad (9)$$

If the water is to be permitted to abstract an appreciable portion of the air from the air-vessel, that is, if the air-vessel is not to be frequently recharged, then the coefficient in the above equation should be greater than 15. If the air-vessel is to be recharged often, mechanically, with volumes of air greater than the atmospheric pressure would supply, then the coefficient may be some less than 15.

FIG. 136.

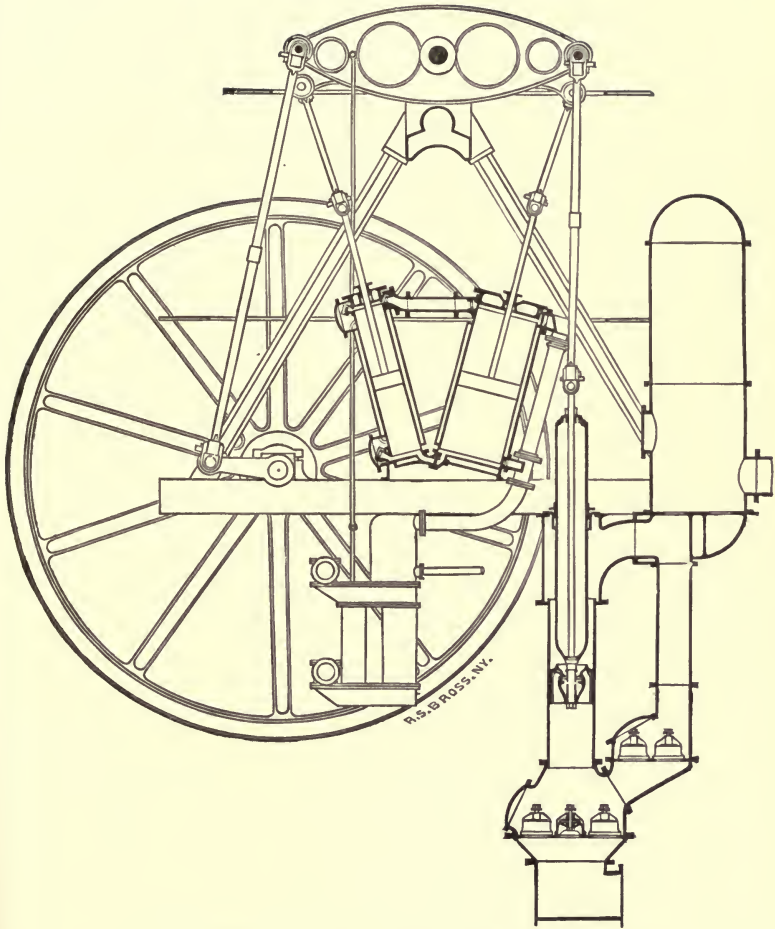

LYNN PUMPING ENGINE.—(E. D. Leavitt, Jr.'s, Patent.)

The larger the water surface in contact with the air in the air-vessel, the faster the air is absorbed by the water ; therefore it is advisable to give considerable height in proportion to diameter to the air-vessel, and a disk of wood or other nearly or quite impervious material, one or two inches less in diameter than the air-vessel, may be allowed to lie on the water in the vessel, and thus still more reduce the surfaces of contact of air and water.

544. Valves.—Pumps that have to lift water to heights greater than thirty feet, are usually of necessity, or for convenience of access, placed between the water to be raised and the point of delivery. When so situated they perform two distinct operations, one of which is to draw the water to them, and the other to force it up to the desired elevation. When the pump piston or plunger advances,

FIG. 137.

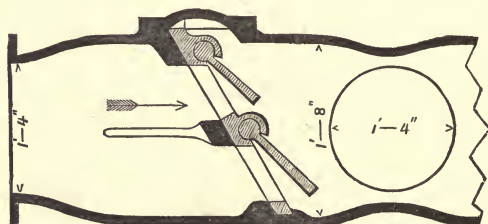

the water in front of it is pressed forward, and at the same time the pressure of the atmosphere forces in water to fill the space or vacuum that it would otherwise leave behind it. The return of the water must be prevented, or the work done by lifting it will be wasted. *Valves* which open freely to forward motion of the water and close against its return, are, therefore, a necessity, both upon the suction and the delivery sides of the pump.

All valves break up and distort, in some degree, the advancing column of water. Such distortions and divisions

cause frictional resistance, which consumes power. The valve that admits the passage of the column of water by or through it with the least division or deflection from its direct course, neutralizes least of the motive power. Short bends and contractions in water passages, that consume a great deal of power or equivalent head, often occur in their worst degree in pump valves.

The *piston valve* which moves entirely out of the water-passage, and permits the flow of water in a single cylindrical column, such for instance as was used in the Darlington and Junker *water-engines*,* is perhaps least objectionable in the matter of frictional resistance to the moving water, but is often inconvenient to use. The single flap-valve (Fig. 137), with area at 30° lift exceeding the sectional area of the pump cylinder, gives also a minimum amount of frictional resistance.

The single annular form of column, while passing through the valve, is less objectionable than any of the other divisions of the water, and annular valve openings have been the favorite forms in nearly all the large pumping machines.

In some of the earlier pumps the suction was through a single valve with two annular openings, after the Harvey and West model, or, as more familiarly known, the Cornish double-beat valve, similar to Fig. 138, illustrating the valves used in the Brooklyn engines.

When pumps began to be built of great magnitude, requiring large capacities for flow, and the valves were increased in size to two feet diameter and upward, the valves were found to strike very powerful blows as they

* *Vide* illustration of a water-engine in Rankine's "Steam Engine," p. 140, London, 1873, and Lardner's Hydrostatics and Pneumatics, p. 312, London, 1874.

FIG. 138.

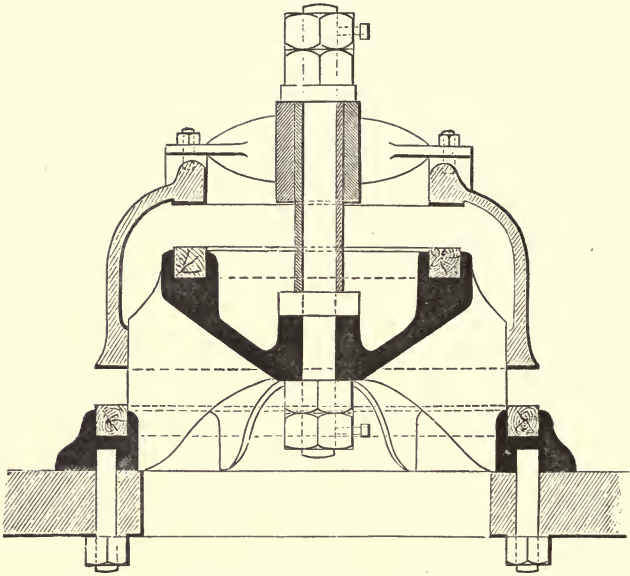

came upon their seats, and to make the whole machine, the building, and the earth around the foundations tremble.

This annoyance led to dividing the valves into nests of five or more valves of similar double-beat form. In London and other large English cities the valves have of late been of the *four-beat* class, or Husband's model.

In many pumps the valves have of late been divided into nests of twelve or more rubber-disks (Fig. 139) in each set, seating upon grated openings in a flat valve-plate. Each subdivision increases the frictional resistance, but reduces the force of the blow, or *water-hammer*, when the valve strikes its seat.

The suction and delivery valves of the piston pumps (Fig. 134) were usually of the flap or hinged pattern. These piston-pumps had sometimes, though rarely, their cylinders placed vertically, as at the Centre Square Works erected in

Philadelphia in 1801, and at the Schuylkill Works erected in the same city in 1844. They were inclined ten or twelve degrees from the horizontal at Montreal.

The horizontal plunger, or "Worthington" pumps (page 223), have uniformly been fitted with nests of rubber disk valves.

The best of the modern steam fire-engines are fitted with nests of rubber disk valves, showing that this class of valve is a favorite when the pressure is great and the motion is rapid.

The rubber disk valve (Fig. 139) was sketched from an Amoskeag fire-steamer valve.

545. Motion of Water Through Pumps.—Water is so heavy and inelastic that large columns of it cannot be quickly started or stopped, without the exertion or opposition of great power to overcome its inertia, or *vis viva*. There is therefore an advantage, as respects the even and moderate consumption of power, when the piston or plunger motion is reciprocal, in making the strokes long, and few per minute.

The case is entirely different with an elastic fluid like steam. The tendency of the most successful modern steam engineering has been toward quick strokes and high steam pressures, and with high degrees of expansion in the larger engines.

The "indoor" ends of the beams of the best Cornish pumping-engines are longer than the "outdoor" ends, and it is claimed as one of their special advantages that the indoor or steam stroke that lifts the plunger pole can be made

FIG. 139.

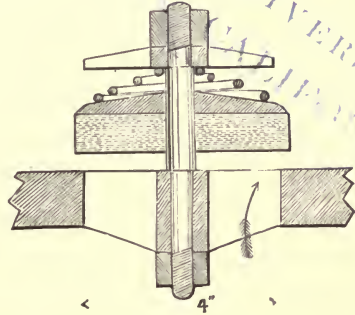

with rapidity, while the outdoor stroke, or fall of the plunger by its own weight, can be gradual, and thus the water be pressed forward at a nearly steady and uniform rate. The single-cylinder, single-acting, non-rotative Cornish engine is admirably adapted to the work to which it was early applied by Watt and Boulton—namely, the raising of water from the deep pits of mines by successive lifts to the surface adits, where it flowed freely away; but when applied to long force-mains of water-supplies, a stand-pipe near the pump becomes a necessity to neutralize the straining and laborious effects of the intermittent action.

546. Double-Acting Pumping-Engines.—The desire to overcome the objectionable intermittent delivery of the single-acting pump, as well as the influence of the sharp competition among engine-builders, that forced them to study methods of economizing the first cost of the machines while maintaining their capacity and economy of action, led to the introduction, for water-supply pumping, of the compound or double cylinder, double-acting, rotative or fly-wheel engine. This last class of engines was brought to a high state of perfection by Mr. Wicksted and Mr. Simpson at the London pumping stations. Some admirable pumping machines of this class have been constructed for American water-works from designs of Messrs. Wright, Cregeir, Leavitt, and others.

547. Geared Pumping-Engines.—Geared compound pumping-engines, one style of which (the Nagle) is shown in side and end elevations* in Figs. 140 (p. 377) and 141 (p. 573), are well adapted both for direct pumping, and also where the reservoir and direct systems are combined. Advantage

* From the design adopted for the Providence High Service, and working with direct pressure.

FIG. 140.

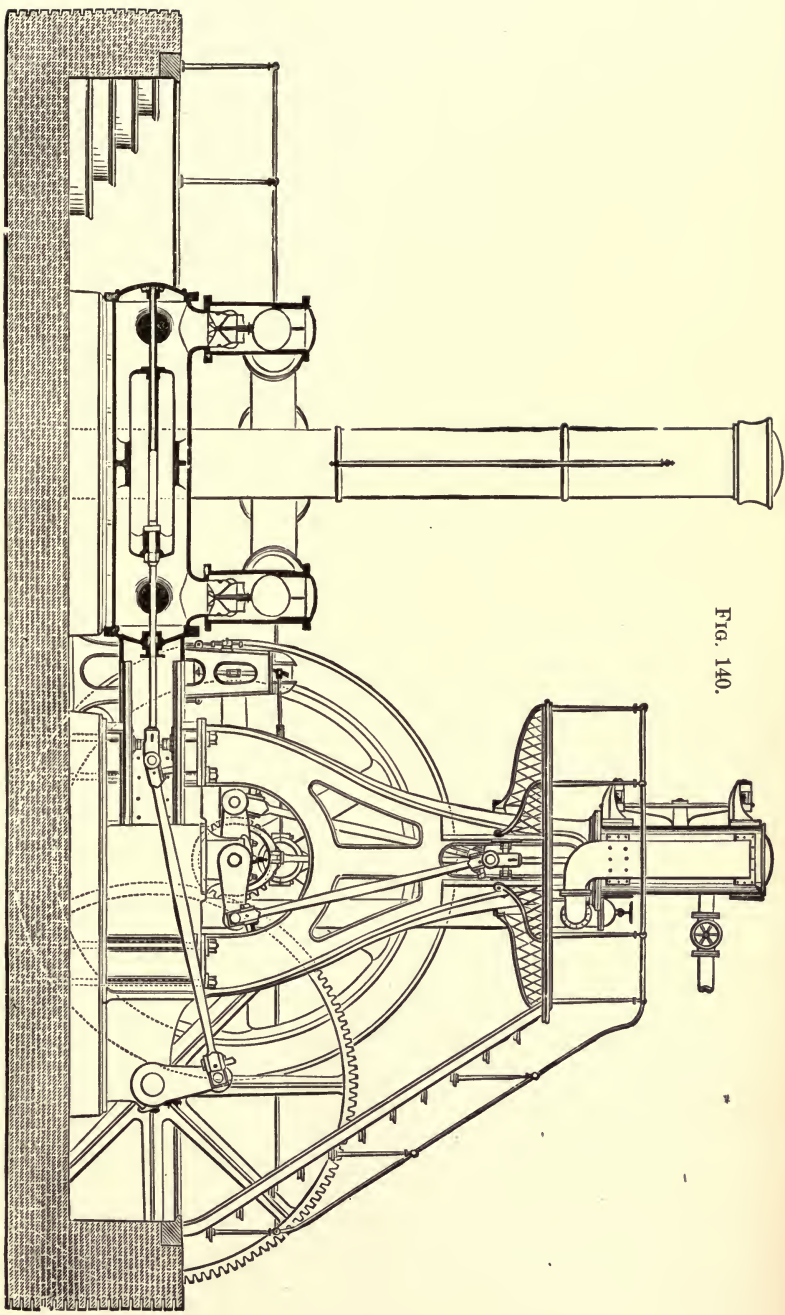

A. F. NAGLE.
FRONT ELEVATION—Sectional through Centre of Pump.
NAGLE'S GEARED PUMPING ENGINE.



Fig. 141.

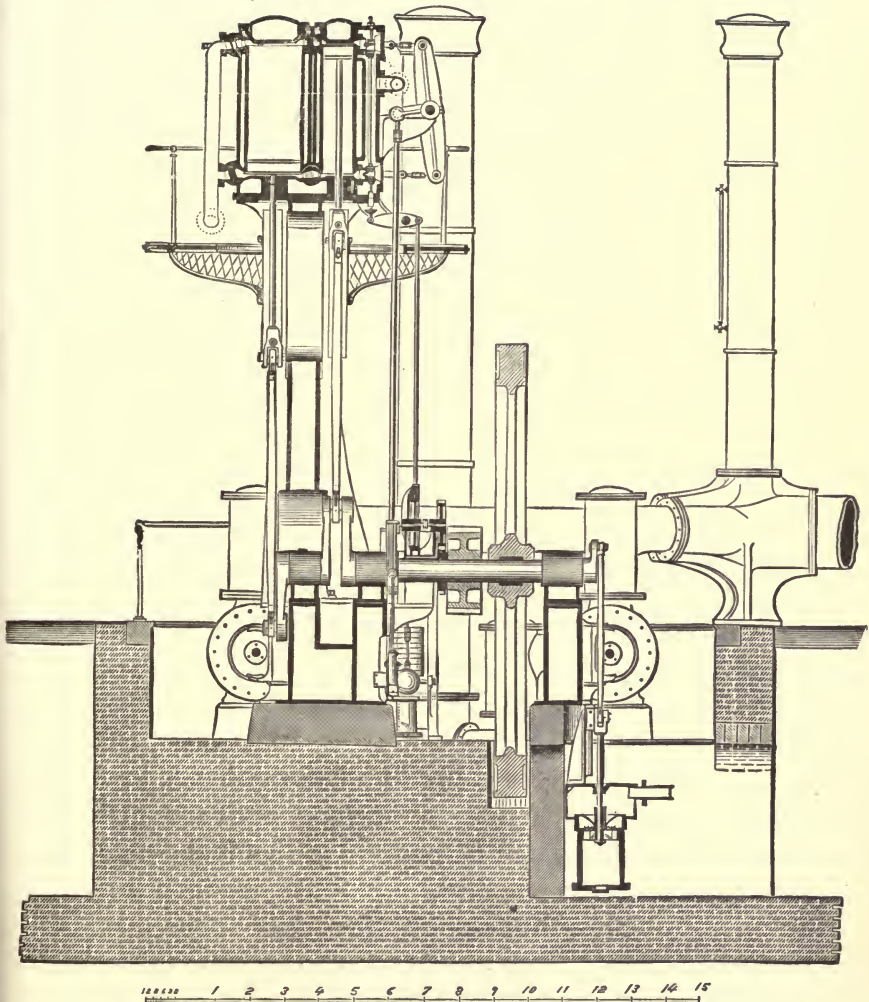

CROSS SECTIONAL ELEVATION.

A. F. NAGLE.

NAGLE'S GEARED PUMPING ENGINE.

may here be taken of high pressure of steam, rapid steam piston stroke, and large degree of steam expansion, while the water piston moves relatively slow with a minimum number of reversals.

548. Costs of Pumping Water.—The following table (p. 575) gives the running expenses for pumping water in various cities.

549. Duty of Pumping Engines.—The *duty* or effective work of a steam pumping-engine, as now usually expressed, is the *ratio* of the product, in foot-pounds, of the weight of water into the height it is lifted, to one hundred pounds of the coal burned to lift the water.

This standard is an outgrowth from that established by Watt, about the year 1780, for the purpose of comparing the performances of pumping-engines in the Cornish mines, when Messrs. Boulton and Watt first introduced their improved pumping-engines upon condition that their compensation was to be derived from a share of the saving in fuel. Watt first used a bushel of coal as the unit of measure of fuel, equal to about 94 pounds, and afterward a cwt. of coal, equal to 112 pounds. More recently, in European practice, and generally in American practice, 100 pounds of coal is the unit of measure of fuel. In some recent refined experiments, the weight of ashes and clinkers is deducted, and the unit of measure of fuel is the combustible portion of 100 pounds of coal. The use of these several units, differing but slightly from each other in value, leads to confusion or apparent wide discrepancies in results, when the performances of different pumping-engines are compared, unless the results are all reduced to an uniform standard.

To construct an equation in conformity with the more generally accepted standard of duty, let Q be the volume

GEARED PUMPING ENGINE.

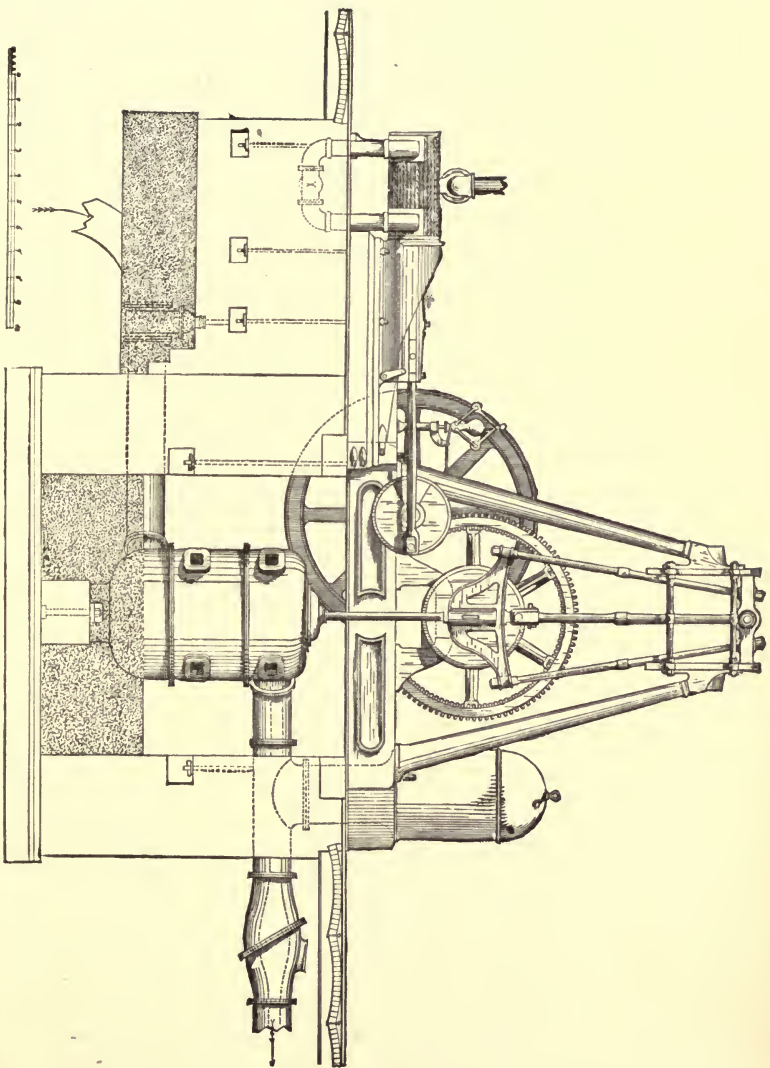

SIDE ELEVATION. - J. T. FANNING, C. E.

GEARED PUMPING ENGINE.

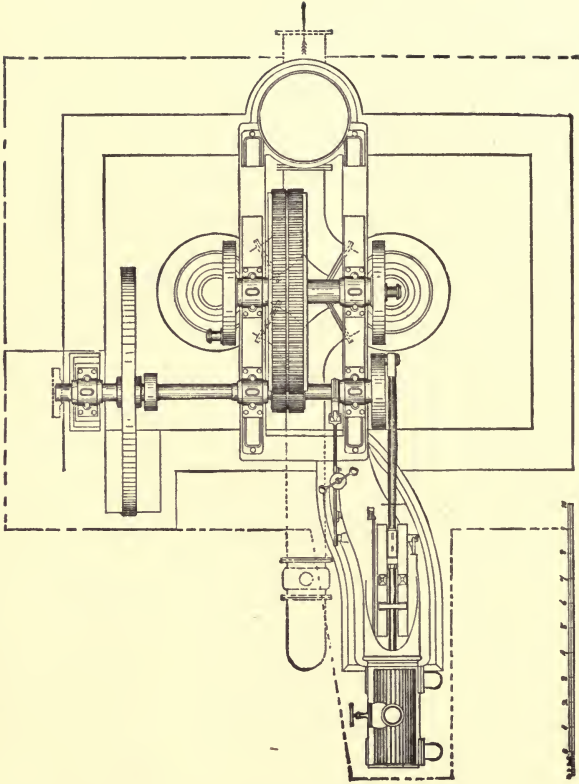

PLAN.—J. T. FANNING, C. E.

of water delivered in any given time into the force-main, in gallons; w the weight* of a gallon of water in pounds (= 8.34 lbs. approximately); H the dynamic height of lift; h the height equivalent to the frictional resistance between pumps and reservoir, including resistances of flow, valves, bends, etc., in the force-main, but not the work due to intermittent motion of pumps, or to bends and frictions within the pump itself; W the weight, in pounds, of coal passed into the furnace in the given time; and D the duty per 100 pounds of coal; then

$$D = \frac{Q \times w \times (H + h)}{.01 W}. \quad (10)$$

Sometimes the value of Q is expressed in cubic feet, in which case w is the weight in pounds of a cubic foot of water (= 62.33 lbs. approximately).

If it is preferred to use the area of plunger, its mean rate of motion in the given time, and the pressure against which it moves, as factors in the calculation, then the equivalent equation of duty D , takes the form,

$$D = \frac{cA \times V \times t \times (P + p)}{.01 W}, \quad (11)$$

in which A is the area, in square feet, of the piston or bucket, and c its coefficient of effective delivery, which varies from .60 to .98, according to design or condition of the valves and velocity of flow through them; V the mean rate of motion, in feet per minute, of the plunger or bucket; t the given time, in minutes; P the pressure, in pounds, due to the dynamic head; p the pressure in pounds due to the resistances in the force-main; and W the weight of

* *Vide* Table 38 for weights of water per cubic foot, at different temperatures.

coal, in pounds, passed into the furnace in the given time.

If W is taken for denominator in the equation instead of $.01 W$, then the result gives the duty per pound of coal.

The numerator in each equation refers to the foot-pounds of work done by the plunger or bucket of the pump in effective delivery of water into and efflux from the force-main, and the denominator refers to the foot-pounds of work converted from the heat in the coal, and effectively applied by the combination of boiler and steam engine.

The coefficient c and the terms h and p in equations 10 and 11 are ordinarily appreciably variable with variable rates of plunger or bucket motion. Preliminary to a general duty test of a pump the values of c for different velocities or rates of piston motion, from minimum to maximum, should be determined by a reliable and accurate weight or weir test, and the value of h or p be accurately determined for similar conditions by an accurate gauge or pressure test, and a scale, per unit of velocity prepared for each, so that values may be read off for the actual rates of piston motion during the general test.

The main parts or divisions which make up a steam pumping engine, are :

1. Boilers (including grates, heating surfaces, steam and water spaces, and flues).
2. Steam engine (including steam pipes, cylinders, valves, pistons, and condensing apparatus).
3. Pump (including water passages, cylinders, plunger or bucket, and valves).

In comparisons of data, for the selection or design of the parts of such a combination, the classes of each part should be considered in detail, independently, with prime costs,

since if either part gives a low duty alone, the duty of the combination will suffer in consequence.

Attention will be given especially to the evaporative power of the boiler and its duty, or ratio of effective to theoretical pressure delivered into the steam pipe; the effective piston pressure capabilities or duty of the steam cylinder, over and above its condensations, enhanced by slow motion, leakages of steam, and frictions; and the frictional resistances of the pump piston or plunger, and valves, and reactions in the water passages.

Each pound of good coal, according to the dynamic theory of heat, contains in its combustible part about 12,000 heat units, which are developed into a force by the burning of the coal to produce steam, and this force is capable of performing a definite amount of work. From sixteen to twenty per cent. of these heat units are, ordinarily, lost by escape up the chimney; sixteen to twenty per cent additional are lost by condensation of the steam in the pipes and cylinders, and by leakage past the piston or valves into the condenser, and about fifty per cent. of their equivalents escape with the exhaust steam into the condenser. Only about ten or twelve per cent. of these heat units are ordinarily transformed into actual useful work done by the steam.

If the engine has many rubbing surfaces, or binds at any bearing, or if the pumps have crooked water passages, many divisions of the jet in the valves, frequent and rapid startings and checkings of the water column, or if it binds at any bearing, then each of these resistances consume a portion of the remaining ten or twelve per cent. of useful work of the steam.

Stability and substantiality are matters of the utmost importance to be considered in the selection of a class or

manufacture of pumping engines. By these terms, in this connection, we mean the capability of endurance of continuous action at the standard rate and work, without stoppage for repairs, and with the minimum expenditure for repairs.

This power of continuous work at a maximum rate is of far greater value, ordinarily, than an extremely high duty, if stability is sacrificed in part for the attainment of a high duty, for the comfort and safety of the city may be jeopardized by a weakness in its pumping engine. Stability being first attained, then duty becomes an element of excellence and superiority.

FIG. 142.

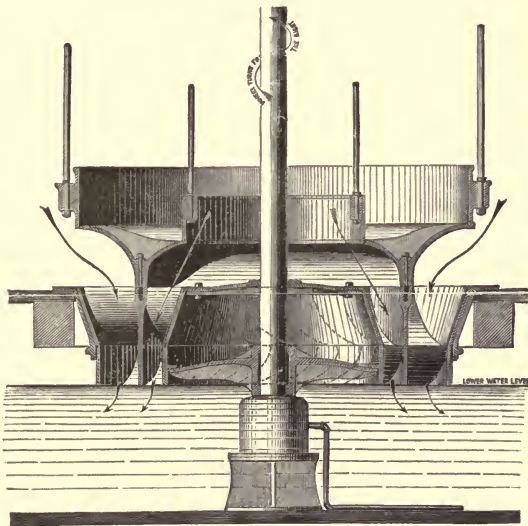

GEVELIN'S DUPLEX-JONVAL TURBINE (R. D. WOOD & CO., PHILA.)

550. Special Trial Duties.—The following table (page 580) gives the duty results obtained by special trials of various engines, under the direction of experts.*

551. Economy of a High Duty.—The financial value of a high *duty* is too often overlooked.

* *Vide* report of Messrs. Low, Roberts and Bogart ; in Journal of American Society of Civil Engineers. Vol. IV, p. 142.

T A B L E N O . 1 1 3 . — S P E C I A L T R I A L D U T I E S O F V A R I O U S P U M P I N G E N G I N E S .

CITY.	CLASS OF ENGINE.	CLASS OF PUMPS.	Year.	DUTIES PER HUNDRED POUNDS OF COAL.					Dynamic lift in feet.
				Pounds of water, reduced to standard temperature of air	By evaporation in boilers.	By pressure in steam cylinders.	By pressure on pump.	By dynamic lift and measurement of water delivered.	
Brooklyn, N. Y.	No. 1, double acting beam	Vertical sing. act. doub. beat valves.	1860	60,798,200	176
"	No. 1, altered to double-acting beam and fly-wheel	"	1871	60,040,560	176
"	No. 2, double-acting beam	"	1861	60,790,742	60,418,011	176.3
"	No. 2, " and fly-wheel	Vertical bucket and plunger and double-beat valves	1871	81,432,300	54,395,262	176
"	No. 3, " and fly-wheel	"	1869	11.099	827,776,739	68,387,200	64,147,194	176
"	Mt. Prospect, beam and fly-wheel	"	1871	64,957,700	60,875,994
"	"	"	1862	68,104,200
Cambridge, Mass.	Worthington, horizontal compound, direct	Horizontal plunger, disk valves.	1857	71,278,486	78.3
Cincinnati, Ohio	No. 3, combination, non-condens & fly-wheel	Doub. act. piston, flap valves	8.51	634,686,012	46,665,095	43,566,178	36,172,001	180.7
"	No. 6, Shields, vert. direct acting.	" rubber bar valves	9.98	744,320,376	25,588,007	23,580,687	21,215,510	240
Fall River, Mass.	Hori. crank and fly-wheel, direct.	Horizontal piston, disk valves	49,245,186
Hartford, Conn.	Rotative beam	"	1856	12.425	926,671,410	71,899,664	62,661,715	58,776,689	137.7
"	"	"	1857	68,974,549	137.7
New York City, High Bridge	Direct acting vert. with fly-wheel	Bucket and plunger, doub. beat valves	64,795,200
Jersey City, N. J.	Cornish	Vertical plunger, doub. beat valves	1856	11.082	826,308,858	87,832,671	72,115,396	65,524,049	166
Lawrence, Mass.	Leavitt, rotative beam, compound	Bucket and plunger, doub. beat valves	1876	9.430	117,236,500	98,261,700	168
Lowell, " "	Simpson, " " "	" " " "	93,022,272	80,607,600	164.3
Lynn, " "	Leavitt, " " "	" " " "	1873	10.06	759,286,872	103,623,215	99,776,678	164
Milwaukee, Wis.	Compound beam and fly-wheel	" " " "	1875	10.132	755,641,802	114,185,226	70,955,720	143
"	Worthington, horizontal duplex compound, direct	Horizontal plunger, disk valves
Newark, N. J.	McAlpine, beam and fly-wheel	Horizontal plunger, disk valves	1870	77,457,840	76,584,894	174.8
New Bedford, Mass.	Cornish, radial horizontal, direct compound	Bucket piston, butterfly valves	1869	59,336,497	137.6
Providence, R. I.	Worthington, horizontal duplex compound	Double-acting piston	1874	25,865,740	23,176,384	82.2
"	"	Horizontal plunger, disk valves	1874	53,528,210	50,574,955	171
"	Nagle, geared vertical compound	Horizontal plunger, doub. beat valves	1875	84,637,245
Philadelphia, Pa.	Worthington, horizontal duplex compound	Horizontal plunger, disk valves	9.104	678,987,245	54,416,694	208

THREE-CYLINDER TUBULAR BOILER.

NEWPORT, R. I., WATER WORKS.

[CONSTRUCTED FOR GEORGE H. NORMAN, PROPRIETOR.]

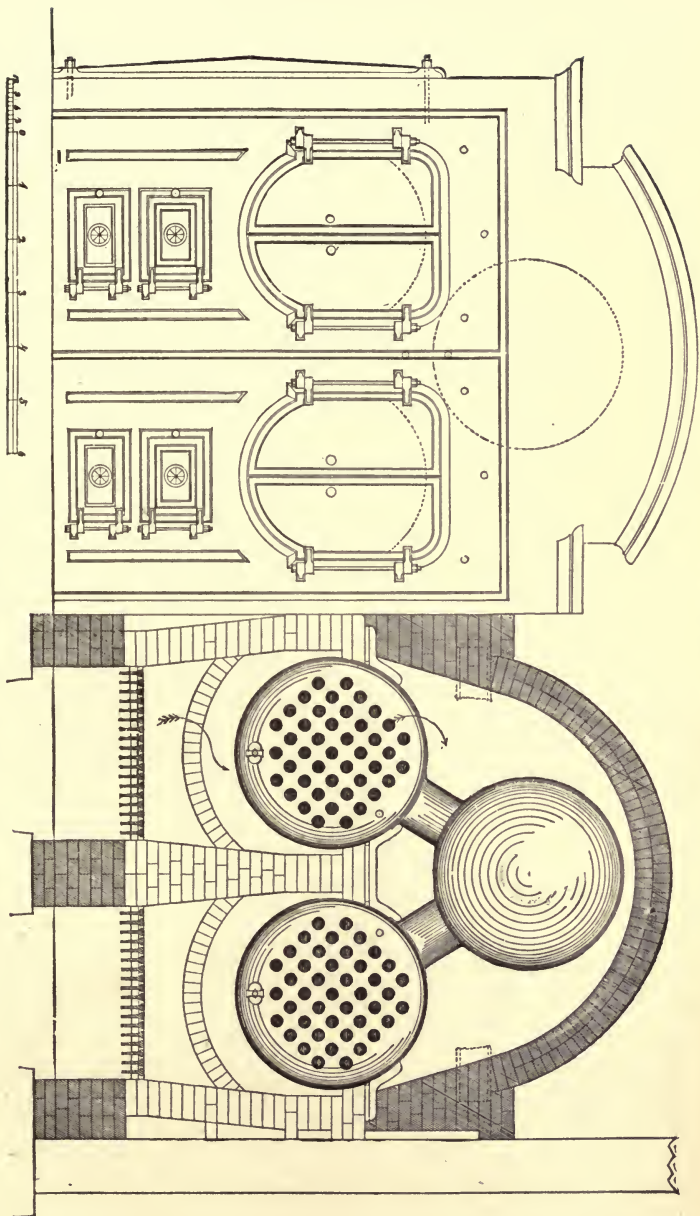

FRONT ELEVATION.—J. T. FANNING'S PATENT.

THREE-CYLINDER TUBULAR BOILER.
NEWPORT, R. I., WATER WORKS.

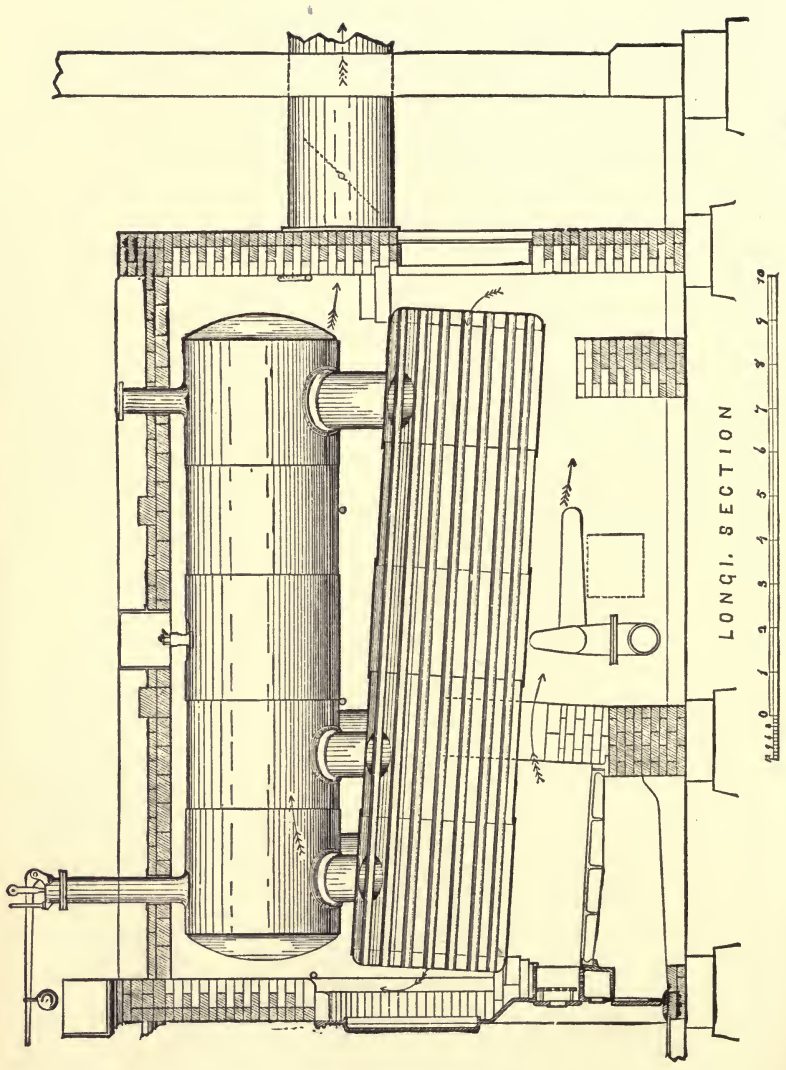

LONG. SECTION
SIDE ELEVATION. — J. T. FANNING'S PATENT.

Engines of substantial construction can now be readily obtained, that, when working continuously at their standard capacities, will give duties of from 75 to 100 million foot-pounds per 100 pounds of coal. When they are realizing less than their maximum duties, money, or its equivalent, goes to waste.

We have just seen (§ 549) that duty is a ratio of effective work. If we divide the dynamic work to be done by this ratio, then we have the pounds of coal required to do the work when the given duty is realized.

Let D be the given duty in foot-pounds per 100 pounds of coal; Q the volume of water delivered into the force-main in gallons; w the weight of a gallon of water, in pounds (= 8.34 lbs., approximately); H the actual height of lift; h the height equivalent to the frictional resistances in the main; and W the weight of coal required, in pounds; then we have for equation of weight of coal,

$$W = \frac{100Q \times w \times (H + h)}{D}. \tag{12}$$

When Q and D are in even millions, the computation will be shortened by taking one million as the unit for those quantities.

Let us assume that we have one million gallons of water to lift 100 feet high in twenty-four hours, then the pounds of coal required at various duties will be approximately as follows:

TABLE No. 114.

COMPARATIVE CONSUMPTIONS OF COAL AT DIFFERENT DUTIES.

Duty, in millions	105	100	95	90	85	80	75	70
Pounds of coal.....	794	834	878	927	981	1042	1112	1191
Duty, in millions	65	60	55	50	45	40	30	20
Pounds of coal.....	1283	1390	1516	1668	1853	2085	2780	4170

The relative costs per annum, in dollars, for lifting various quantities of water daily 100 feet high, at different duties, will be approximately as in the following table, on the assumption that the coal costs \$8 per ton of 2000 pounds, when delivered into the furnace.

TABLE No. 115.

FUEL EXPENSES FOR PUMPING, COMPARED ON DUTY BASES.

Duty in millions of foot-pounds.	Number of millions of gallons pumped daily, one hundred feet high. (Coal in furnace at \$8 per ton.)						
	1	2	3	4	6	8	10
	<i>Cost of coal per annum, in dollars.</i>						
100	\$1277.86	\$2556	\$3834	\$5111	\$7667	\$10223	\$12779
90	1419.85	2840	4260	5679	8519	11359	14198
80	1597.32	3195	4792	6389	9584	12778	15973
70	1825.51	3651	5477	7302	10953	14604	18255
60	2129.76	4260	6389	8519	12779	17038	21298
50	2555.72	5111	7667	10223	15334	20446	25557
40	3194.65	6389	9584	12769	19168	25537	31946
30	4259.53	8519	12779	17038	25557	34076	42595
20	6389.30	12768	19168	25537	39336	51174	63893

If the lift is 150 feet, then the annual cost will be one and one-half times the above amounts respectively, if 200 feet, twice the above amounts, etc.

If we have four million gallons per day to pump 100 feet high, then the cost of coal per annum for a 100 million duty engine will be about \$5000, and with a 20 million duty engine about \$25000. If we have to pump the same water 200 feet, the coal for the first engine will cost about \$10,200 and with the second engine \$51,000. These sums capitalized represent the relative financial values of the engines, so far as relates to cost of fuel.

If pumping-engines are sufficiently strong, of good mechanical workmanship, and simple in arrangement of parts, then the cost of attendance, lubricants, and ordinary repairs, while doing a given work, will be substantially the

same for different makes or designs. Beyond this the relative merits of machines of equal stability, independent of prime cost, are nearly in the inverse order of the amount of fuel they require to do a given work.

But the first costs of the complete combination should be made a factor in the comparison, including costs of foundations and extra costs of buildings, standpipes, etc., if required, as in the case of Cornish engines. Then the relative economic merits are inversely as the products of costs into reciprocals of duties, or directly as duty divided by cost.

Let C_a be the cost in dollars of the complete pumping-engine, including foundations, pump-wells, etc., and D the duty in millions, then the most economic engine, so far as relates to cost of fuel, will be that which has the least product of $C_a \times \frac{1}{D}$, or $\frac{C_a}{D}$, and the relative result will be very nearly the same if the cost of engine is capitalized.

Let $\%$ be the per cent., or rate of interest at which the cost is capitalized, then the most economic engine, as to prime cost and duty, will be that which has the least product of $\frac{C_a}{\%} \times \frac{1}{D}$, or $\frac{1}{\%} \times \frac{C_a}{D}$.

Let us assume that we have five million gallons of water to lift 100 feet high per day, and that a standard engine of suitable capacity to do the work, realizing one hundred million duty, will cost \$65,000.

With this standard let us compare, financially, engines of less first cost and giving less duties, as in the following table, in which the ratio of the standard is taken equal unity.

TABLE No. 116.

COMPARISON OF VALUES OF PUMPING-ENGINES OF VARIOUS PRIME COSTS AND DUTIES ON FUEL BASES.

Cost = C_d .	DUTY = D .	$C_d \times \frac{1}{D} = \frac{C_d}{D}$.	RATIO.
\$65,000	100 M.	650.0	1.
60,000	90 "	666.6	1.025
50,000	75 "	666.6	1.025
45,000	60 "	750.0	1.153
35,000	50 "	700.0	1.077
25,000	30 "	833.3	1.282

By the column of ratios in the table we learn that the \$25,000 engine will really cost twenty-eight per cent. more per annum than the \$65,000 engine, for the same work, and that the purchase of the assumed standard engine, if it has stability equal to that of the lower-priced engine, will lead to the most profitable results.

In the table, the \$50,000 pumping-engine giving a seventy-five million duty, is seen to have a financial value almost identical with that of the assumed standard engine. If it is also freer from liability to breakage or interruption, if it requires less labor or less skill in attendance, if it is easier in adjustment to varying work when variable work is to be performed, or if it is better adapted mechanically to the special work to be performed, then the practical over-balances the financial advantages, and it is obviously entitled to preference in the selection, and good judgment will lead to the purchase of this rather than of the assumed standard engine.

FIG. 143.

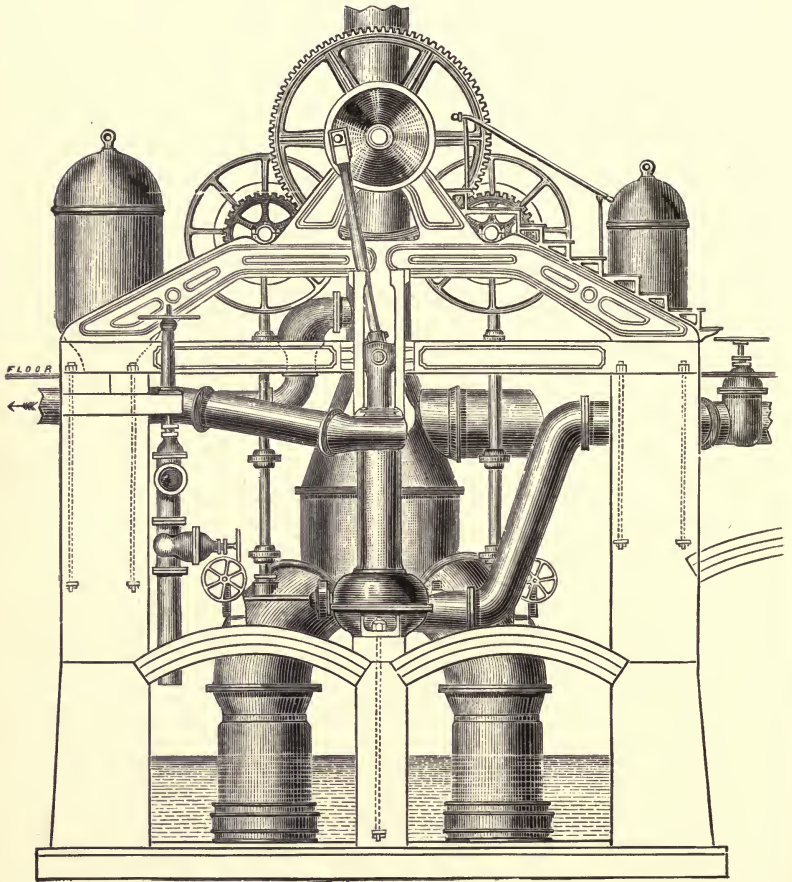

TURBINES AND PUMPS, MANCHESTER.

CHAPTER XXV.

SYSTEMS OF WATER SUPPLY.

552. Permanence of Supply Essential.—Let the projector of a public water supply first make himself familiar with the possible scope and objects of a good and ample system of water supply, and become fully conscious of how intimately it is to be connected with the well-being of the people and their active industries in all departments of their arts, mechanics, trade, and commerce, as well as in their culinary operations, and let him also appreciate the consequences of its failure, or partial failure after a season of success.

When the people have become accustomed to the ready flow from the faucets, at the sinks and basins, and in the shops and warehouses, then, if the pumps cease motion or the valve is closed at the reservoir, the household operations, from laundry to nursery, are brought to a standstill—engines in the shops cease motion, hydraulic hoists and motors in the warehouses cease to handle goods, railway trains, ocean steamers, and coasters delay for water, and a general paralysis checks the busy activity of the city. What a thrill is then given by an alarm of fire, because there is no pressure or flow at the hydrants!

The precious waters of the reservoirs preside over cities with protecting influences, enhancing prosperity, comfort, safety and health, and are not myths, as were the goddesses in ancient mythology, presiding over harvests, flowers, fruits, health and happiness.

Let the designer and builder of the public water system feel that his work must be complete, durable, and unfailing, and let this feeling guide his whole thought and energy, then there is little danger of his going astray as to system, whether it be called "gravitation," "reservoir," "stand-pipe," or "direct pressure," or of his being enamored with lauded but suspicious mechanical pumping automatons, and uncertain valve and hydrant fixtures.

When the people have learned to depend, or must of necessity depend, upon the public pipes for their indispensable water, it must flow unceasingly as does the blood in our veins. All elements of uncertainty must be overcome, and the safest and most reliable structures and machines be provided.

Many times, in different cities, a neglect, apparently slight, has cost, through failure, a fearful amount, when sacrificed life and treasure and a broad smouldering swarth across the city were the penalty. Having water-works is not always having full protection, unless they are fully adequate for the most trying hour.

553. Methods of Gathering and Delivering Water.

—There is no mystery about "*systems*" of water supply, as they have of late been often classified. The problem is simply to search out the best method of gathering or securing an ample supply of wholesome water, and then to devise the best method of delivering that supply to the people.

Usually there is one source whose merits and demerits, when intelligently examined, favorably outweighs the merits and demerits of each and every other source, and there is usually one method of delivery that is conspicuously better than all others, when all the local exigencies are seen and foreseen.

The usual methods of gathering the required supply are, to impound and store the rainfall or flow of streams among the hills ; draw from a natural lake ; draw from a running river ; or draw from an artesian well.

The usual methods of delivering water are, by gravitation from an elevated impounding basin ; elevation by steam or water power to a reservoir and from thence a flow by gravity ; elevation to low and high service reservoirs, and from thence flow by gravity to respective districts ; and by forcing with pressure direct into the distribution-pipes, and cushioning the motion by a stand-pipe, or ample air-vessel and relief valve.

554. Choice of Water.—The pumped supplies are usually drawn from lake, river, or subterranean sources.

The selection of a lake or river water for domestic use is to be governed by considerations of wholesome purity ; and cautiousness of financial expenditure must not in this direction exert too strong an influence in opposition to inflexible sanitary laws.

This selection involves an intelligent examination of the origin and character of the impregnations and suspended impurities of the water, and the possibility of their thorough clarification.

None of the waters of Nature are strictly pure. Some of the impurities are really beneficial, while others, which are often present, are not to be accepted or tolerated. A mere suspicion that a water supply is foul or unwholesome, even though not based on substantial fact, is often a serious financial disadvantage ; therefore earnest effort to maintain the purity of the water must extend also to the removal of causes of suspicion.

Chemical science and microscopy are valuable aids in this portion of the investigation of the qualities of waters ;

but we have detailed in the first part of this treatise so minutely the nature and source of the chief impurities, and so carefully pointed out those that are comparatively harmless and those that are deadly, that an intelligent opinion can generally be readily formed of the comparative purities and values of different waters. We have also pointed out how waters may be clarified and conducted in their best condition to the point of delivery, and distributed in the most efficient manner.

Predictions of any value as to quantity and quality of a supply from a proposed artesian well, demand a knowledge of the local geology and subterranean hydrology, which is rarely obtainable until the completion and test of the well; nevertheless we have shown the conditions under which a good supply of water may be anticipated with reasonable confidence.

555. Gravitation.—When a good and abundant supply of water can be gathered at a sufficient elevation, and within an accessible distance, the essential element of continuous full-pressure delivery can then most certainly be secured, and in the matter of possible safety the gravitation method will usually be superior to all others.

The quality of impounded water, when gathered in small storage reservoirs and from relatively limited watersheds, is subject to some of those unpleasant influences, heretofore referred to, which are to be provided against; and unless the hydrology and substructure of the gathering basin is well understood, the permanence of the supply may not fulfill enthusiastic anticipations.

The value and importance of sufficient elevation of the supplying reservoir, when the delivery is by gravity, to meet the most pressing needs of the fire-service, ought not to be overlooked, for an efficient fire-service is usually one

of the chief objects to be attained in a complete water supply.

A water pressure of sixty to eighty pounds per square inch in the hydrants in the vicinity of an incipient fire, has a value which cannot be wholly replaced by a brigade of fire-steamers in commission, for with light-hose carriages and trained hosemen, connection will usually be made with the hydrants, streams be put in motion, and the fire overpowered before pressure is raised in the steamer's boilers ; and the fire will not be suffered to assume unconquerable headway during the delay.

Constant liberal pressures in the hydrants is the first element of prompt and effective attack upon a fire immediately after an alarm is given. Each moment lost before the beginning of an energetic attack increases greatly the difficulty of subduing the fire, and the probability of a vast conflagration.

The element of distance of a gravitation supply, as regards cost of delivery, is an exacting one, and the lengths of conduit and large main are surprisingly short, while the balance of economy of delivery remains with the side of the gravitation scheme ; for conduits and mains are expensive constructions, and soon absorb more capital and interest than would pay for pumps and fuel for lifting a nearer supply ; still an element of safety is not to be sacrificed for a moderate difference in first cost.

556. Pumping with Reservoir Reserve.—As regards safety and reliability of operation, we place second the method of delivery when the supply is elevated by hydraulic power, and third when it is elevated by steam power to a liberal-sized reservoir holding in store from six to ten days reserve of water, from whence the supply flows by gravity into the distribution-pipes. If in such case there

are duplicate first-class pumping-machines whose combined capacity is equal to the delivery of the whole daily supply in ten hours, or one-half equal to the delivery of the whole daily supply in twenty hours, then this method is scarcely inferior in safety to the gravitation method.

The elements of safety may be equally secured in the low and high service method, when the physical features of the town or city make such division desirable. In a previous chapter we have shown how a union of the high and low service may be made an especially valuable feature in efficient fire service.

The records of nearly all the water departments of our largest cities, having duplicate pumping machinery, show how valuable and indispensable have been their reserve stores of water, and refer to the risks that would have been incurred had such reservoir storages been lacking.

557. Pumping with Direct Pressure.—We place fourth, as regards safety and reliability, the direct pressure delivery by hydraulic power, and fifth, by steam power, with either stand-pipe or air-vessel cushions and safety relief-valves.

The mechanical arrangements that admit of this method of delivery are simple, and several builders of pumping machinery have adapted their manufactures to its special requirements, but in point of continuous reliability the method still remains inferior to gravity flow.

Even when the most substantial and most simple steam pumping machinery is adopted, if not supplemented by an elevated small reserve of water, this method of delivery is accompanied with risks of hot bearings, sudden strains, unexpected fracture of connection, shaft, cylinder, valve-chest or pipe, and occasional necessary stoppages.

The best pumping combinations are so certainly liable

to such contingencies that cities may judiciously hesitate to rely entirely upon the infallibility of their boilers, engines, and pumps, even when so fortunate as to secure attendants upon whom they can place implicit confidence.

The direct pressure method, alone, necessitates unceasing firing of the boiler and motion of the pumping-engine, and consequently double or triple sets of hands, to whose integrity and faithfulness, night and day and at all times, the works are committed.

Hydraulic power and machinery are far more reliable than steam machinery, for direct pressure uses, and hydraulic power presents the great advantage of being able to respond almost instantaneously to the extreme demand for both water and pressure, while a dull fire under the boiler may require many minutes for revival so as to raise the steam to the effective emergency pressure. An example of pumping machinery of five million gallons capacity per diem, driven by hydraulic power, is shown in Fig. 143. This set of pumping machinery was constructed for the city of Manchester, N. H., by the Geyelin department of Messrs. R. D. Wood & Co., Philadelphia, from general designs by the writer, and has operated very satisfactorily since its completion in 1874. This machinery is adapted in all respects to direct pressure service, and was so used during a full season while the reservoir was in process of construction, and it is equally well adapted to its ordinary work of pumping water to the distributing reservoir.

The direct forcing method does not provide for the deposition or removal of impurities after they have passed the engine, but the sediments that reach the pumps are passed forward to the consumers in all sections of the pipe distribution.

In combination with a reservoir sufficient for all the

ordinary purposes, and equalizing the ordinary work and the ordinary pressures at the taps, and also in combination with a very small reservoir, the direct pressure facilities may prove a most valuable auxiliary in times of emergency, and they are then well worth the insignificant difference in first cost of pumping machinery.

In the smaller works the entire machinery, and in larger works one-half the machinery, may with advantage be capable of and adapted for direct pressure action.

If, instead of substantial and simple machinery built especially for long and reliable service, some one of the intricate and fragile machines freely offered in the market for direct pumping is substituted, and is not supplemented by an ample reservoir reserve, then a risk is assumed which no city can knowingly afford to suffer; and if true principles of economy of working are applied, it will generally be found that no city can, upon well-established business theories, afford to purchase and operate such machinery.

Well designed and substantially constructed pumping-machines, such as are now offered by several reliable builders, when contrasted with several of the low-priced and low-duty contrivances, are most economical in operation, most economical in maintenance, and infinitely superior in reliability for long-continuous work.

LIBRARY
UNIVERSITY OF
CALIFORNIA.

APPENDIX.

THE METRIC SYSTEM OF WEIGHTS AND MEASURES.

The use of the metric system of measure and weights was legalized in the United States in 1866 by the National Government, and is used in the coast survey by the engineer corps, and to considerable extent in the arts and trades.

Several of the best treatises on theoretical hydraulics give their lengths and volumes in metric measures, and we give their equivalents in United States measures in the following tables.

The *metre*, which is the unit of *length*, *area*, and volume, equals 39.37079 inches or 3.280899 feet in length lineal, and along each edge of its cube.

This unit is, for measures of length, multiplied decimally into the *decametre*, *hectometre*, *kilometre*, and *myriametre*, and is subdivided decimally into the *decimetre*, *centimetre*, and *millimetre*.

The affixes are derived from the Greek for multiplication by ten, and from the Latin for division by ten.

The measures for surface and volume are similarly divided.

The *gramme* is the unit of weight, and it is equal to the weight of a cubic centimetre of water, at its maximum density, in *vacuo*. = .0022046 lbs.

A cubic metre of water, at its maximum density, weighs 2204.6 lbs. avoird.

TABLE OF FRENCH MEASURES AND UNITED STATES EQUIVALENTS.

Measures of Length.

	No. of Metres.	
1 Millimetre.....	.001	= .0393708 inch = .0032809 foot.
1 Centimetre.....	.01	= .393708 inch = .032809 foot.
1 Decimetre.....	.1	= 3.93708 inches = .3280899 ft. = .1093633 yd.
1 Metre.....	1	= 39.3708 inches = 3.2808992 ft. = .198842 rod = .0006214 mile.
1 Decametre.....	10	= 32.808992 ft. = 1.98842 rods = .0062138 mile.
1 Hectometre.....	100	= 328.08992 ft. = 19.88424 rods = .062138 mile.
1 Kilometre.....	1000	= 3280.8992 ft. = 198.8424 rods = .621383 mile.
1 Myriametre.....	10000	= 32808.992 ft. = 1988.424 rods = 6.21383 miles.

Measures of Area.

	No. of sq. Metres.	
1 Centiare.....	1	= 10.7643 sq. ft. = 1.196033 sq. yds. = .039538 sq. rod.
1 Deciare.....	10	= 107.643 sq. ft. = .39538 sq. rd. = .002471 acre.
1 Are.....	100	= 1076.43 sq. ft. = 3.95383 sq. rds. = .02471 acre.
1 Decare (not used)	1000	= 10764.3 sq. ft. = 39.5383 sq. rds. = .2471 acre.
1 Hectare.....	10000	= 107643 sq. ft. = 395.383 sq. rds. = 2.471 acres.

Measures of Volume.

	No. of cu. Metres.	
1 Millilitre.....	.000001	= .0610279 cubic inch.
1 Centilitre.....	.00001	= .610279 cubic inch.
1 Decilitre.....	.0001	= 6.10279 cu. ins. = .00353 cu. ft. = .0264165 gal.
1 Litre.....	.001	= 61.0279 cu. ins. = .0353136 cu. ft. = .264165 gallon.
1 Decalitre.....	.01	= 610.279 cu. ins. = .353136 cu. ft. = .0130791 cu. yard.
1 Hectolitre.....	.1	= 26.4165 gallons = 3.53136 cu. ft. = .130791 cu. yard.
1 Kilolitre.....	1	= 264.1651 gallons = 35.313 cu. ft. = 1.30791 cubic yards.

TABLE OF FRENCH MEASURES AND UNITED STATES EQUIVALENTS
(Continued).

Measures of Solidity.

	No. of cu. Metres.	
I Millistere001	= 61.0279 cubic inches = .03532 cubic foot.
I Centistere01	} = 610.279 cu. ins. = .353166 cu. ft. = .013079 cu. yard.
I Decistere1	
I Stere	1	} = 6102.79 cu. ins. = 3.53166 cu. ft. = .130791 cubic yard.
I Decastere	10	
I Hectostere	100	= 353.166 cu. ft. = 13.0791 cu. yards.
I Kilostere	1000	= 3531.66 cu. ft. = 130.791 cu. yards.

Measures of Weight.

	No. of Grammes.	
I Milligramme001	= .015432 grain.
I Centigramme01	= .15432 grain.
I Decigramme1	= 1.5432 grains = .0035274 oz. Avoir.
I Gramme	1	= 15.432 grs. = .035274 oz. Av. = .002205 lb. Av.
I Decagramme	10	= 154.32 grs. = .35274 oz. Av. = .02205 lb. Av.
I Hectogramme	100	= 1543.2 grs. = 3.5274 oz. Av. = .2205 lb. Av.
I Kilogramme	1000	= 15432 grs. = 35.274 oz. Av. = 2.205 lbs. Av.
I Tonne	= 2204.737 lbs.

A cubic inch is equal to

.004329 gallon; or .0005787 cu. ft; or 16.38901 millilitres; or 1.638901 centilitres; or .1638901 decilitre; or .016389 litre; or .016389 millistere; or .0016389 centistere.

A gallon is equal to

231 cubic inches, .13368 cubic foot; or .031746 liquid barrel; or 3785.513 millilitres; or 378.551 centilitres; or 37.8551 decilitres; or 3.785513 litres; or .3785513 decalitre; or .037855 hectolitre; or .0037855 kilolitre.

A cubic foot is equal to

1728 cubic inches; or 7.48052 liquid gallons; or 6.2321 imperial gallons; or 3.21426 U. S. pecks; or .803564 U. S. struck bushel; or .23748 liquid bar-

rel of $31\frac{1}{2}$ gallons ; or 283.177 centilitres ; or 283.177 decilitres : or 28.3177 litres ; or 2.83177 decalitre ; or .283177 hectolitre ; or .0283177 kilolitre ; or 28.3177 millisteres ; or 2.83177 centisteres ; or .283177 decistere ; or .0283177 stere.

The imperial gallon is equal to

.16046 cu. feet ; or 1.20032 U. S. liquid gallons.

A cubic yard is equal to

46656 cu. inches ; or 201.97404 liquid gallons ; or 27 cu. feet ; or 21.69623 struck bushels ; or 764.578 litres ; or 76.4578 decalitre ; or 7.64578 hectolitres ; or .764578 kilolitre ; or 764.578 milisteres ; or 76.4578 centisteres ; or 7.64578 decisteres ; or .764578 stere ; or .0764578 decastere ; or .0076458 hectostere ; or .00076458 kilostere.

TABLE OF UNITS OF HEADS AND PRESSURES OF WATER AND EQUIVALENTS.

(RANKINE.)

One foot of water at $52^{\circ}.3$ Fah.	= 62.4	lbs. on the square foot.
“ “ “ “	= .433	“ “ “ “ inch.
“ “ “ “	= .0295	atmosphere.
“ “ “ “	= .8823	inch of mercury at 32° .
One lb. on the square foot	= .016026	foot of water.
“ “ “ inch	= 2.308	feet of water.
One atmosphere (= 29.922 in. mercury)	= 33.9	“ “
One inch of mercury, at 32°	= 1.1334	“ “
One cubic foot of average sea-water	= 1.026	cu. ft. of pure water in weight.
One Fahrenheit degree	= .55555	Centigrade degree.
One Centigrade degree	= 1.8	Fahrenheit degrees.
Temperature of melting ice	= 32°	on Fahrenheit's scale.
“ “	= 0	“ Centigrade scale.

TABLE OF AVERAGE WEIGHTS, STRENGTHS, AND ELASTICITIES OF MATERIALS.—(From Trautwine, Neville, and Rankine.)

MATERIALS.	Weight per cu. in.	Weight per cu. ft.	Specific Grav.	Tenacity per sq. in.	Resistance per sq. in. to crushing force.
Woods (seasoned and dry).					
Ash.....	<i>Lbs.</i>	<i>Lbs.</i>		<i>Lbs.</i>	<i>Lbs.</i>
“ American white.....	48.0	0.77	17000	9000
Beech.....	38	.61
.....	48	.77	16000	8500
Cedar, American.....	47	.75	4900
“ “ green.....	56.8	.91	11400	5600
Chestnut.....	41	.66	12000
Elm.....	36.8	.59	13500	10300
“ very dry.....	35	.56
Hemlock.....	25	.40
Hickory.....	53	.85
Maple.....	49	.79
Oak, live.....	59.3	.95	13000	6400
“ white.....	51.8	.83	16000	6500
“ red.....	40.0	10250	6000
Pine, white.....	25.0	.40
“ northern yellow.....	34.3	.55
“ southern “.....	45.0	.72	7800	5400
Spruce.....	25.0	.40	12400	5500
Walnut, black.....	38	.61	7200
Metals.					
Aluminum.....	.99972	162	2.6
Brass, cast.....	.93038	525	8.40	18000	10300
“ rolled.....	524	8.40
“ wire.....	.03085	533	8.54	49000
Bronze (copper 8 parts, tin 1 part).....	.03062	529	8.5	36000
Copper, cast.....	.03113	538	8.61	19000
“ sheet.....	549	8.80	30000
“ wire, drawn.....	.03241	560	8.88	60000
Glass.....	.00885	153	2.45	9400	33000
Iron, cast, cold blast.....	.02552	441	7.07	16700	106000
“ “ hot blast.....	440	7.04	13500	108000
“ “ wrought, sheet or plate.....	.02807	485	7.77	50000
“ “ “ large bars.....	474	7.60	48000
Lead, cast.....	.04152	717	11.44	1800
“ milled.....	713	11.40	3300
Mercury (at 32° Fah., 849 lbs.) (at 212°, } 836 lbs.), at 60°.....	.04896	846	13.58
Silver.....	.0373	644	10.31	40900
Steel.....	.02836	490	7.85	120000
Tin, cast.....	.02637	456	7.30	5300
Zinc.....	.02532	437	7.00	7500
Earth and Stones (dry).					
Asphaltum.....	<i>Cu. ft.</i>	<i>Cu. yd.</i>			
.....	87.3	2357	1.4
Brick, common hard.....	125	3375	280	800
“ soft inferior.....	100	2700
“ best pressed.....	150	4050
Cement, American Rosendale, loose.....	56	1512
“ “ Louisville.....	49.6	1339

Put decimal point to the right.

TABLE OF AVERAGE WEIGHTS, STRENGTHS, ETC.—(Continued).

MATERIALS.	Weight	Weight	Specific	Tenacity	Resist-
	per	per			
	cu. ft.	cu. yd.		per	sq. in. to
				sq. in.	crush-
					ing
					force.
	<i>Lbs.</i>	<i>Lbs.</i>		<i>Lbs.</i>	<i>Lbs.</i>
Cement, English Portland.....	90	2430	280
“ French Boulogne.....	80	2160
Clay, potter's.....	119	3213	1.9
“ dry, in lump, loose.....	63	1701
Concrete.....	556
Coal, bituminous.....	84	2268	1.35
“ broken, loose.....	50	1350
“ a ton occupies 43 to 48 cu. ft.....
Earth, loam, loose.....	75	2025
“ “ moderately rammed.....	95	2565
“ “ as a mud.....	110	2970
Granite.....	168	4536	2.69	10000
“ quarried, in loose piles.....	96	2592
Gneiss.....	168	4536	2.69
“ quarried, in loose piles.....	100	2700
Greenstone.....	187	5049
“ quarried, in loose piles.....	107	2889
Gravel.....	100	2700
“ moderately rammed, dry.....	120	3240	1.90
“ “ “ moist.....	130	3510
Limestone.....	168	4536	2.7	8333
Lime, ground, loose.....	53	1431
Marble.....	165	4455	2.64	5500
Masonry, dressed granite, or limestone..	165	4455
“ well-scabbled mortar rubble of do.	154	4158
“ “ “ dry “ “ do.	138	3726
“ roughly “ “ “ do.	125	3375
“ dressed sandstone.....	144	3888
“ dry rubble “.....	110	2970
“ brickwork, medium.....	125	3375	345
“ “ coarse.....	100	2700
“ “ press'd bricks, close joints	140	3780
Marl.....	110	2970	1.75
Mortar, cement.....	103	2781	1.65	50
Peat, unpressed.....	25	675
Sand, loose.....	100	2700
“ shaken.....	110	2970	1.76
“ wet.....	125	3375
Sandstone.....	150	4050	5000
“ quarried, in loose pile.....	86	2322
Slate.....	180	4873	2.89	12000
Soapstone, or steatite.....	170	4590	2.73
Miscellaneous Materials.					
Ice.....	58.7	1585	0.94	200
Leather.....	4200
Oil, linseed.....	58.6894
Petroleum.....	54.81878
Powder, slightly shaken.....	62.3	1.0
Snow, loose.....	12	324
“ wet and compact.....	50	1350
Water.....	62.334	1693	1.0

FORMULAS FOR SHAFTS.—(Francis.)

Wrought-iron prime movers, with gears:

$$d = \sqrt[3]{\frac{100P}{N}}, \text{ and } P = .01Nd^3.$$

Wrought-iron transmitting shaft:

$$d = \sqrt[3]{\frac{50P}{N}}, \text{ and } P = .02Nd^3.$$

Steel prime mover, with gears:

$$d = \sqrt[3]{\frac{62.5P}{N}}, \text{ and } P = .016Nd^3.$$

Steel transmitting shaft:

$$d = \sqrt[3]{\frac{31.25P}{N}}, \text{ and } P = .032Nd^3.$$

In which d = diameter of shaft in inches.

N = number of revolutions per minute.

P = horse powers.

TRIGONOMETRICAL EXPRESSIONS.

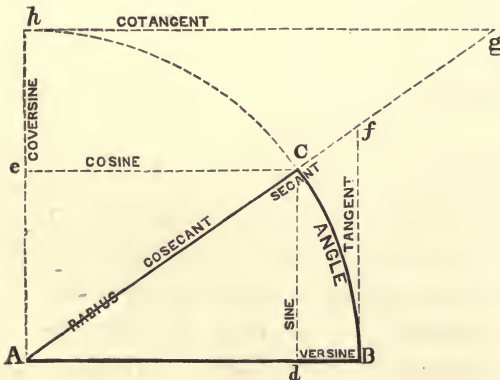

- Radius = AC.
- Sine = Cd.
- Cosine = Ce.
- Tangent = Bf.
- Cotangent = hg.
- Secant = Af.
- Cosecant = Ag.
- Versine = Bd.
- Coversine = he.

TRIGONOMETRICAL EQUIVALENTS, WHEN RADIUS = 1.

Sine	=	$1 \div \text{Cosec.}$
“	=	$\text{Cosin.} \div \text{Cotan.}$
“	=	$\sqrt{1 - \text{Cosin.}^2}$
Cosine	=	$1 \div \text{Sec.}$
“	=	$\text{Sin.} \div \text{Tan.}$
“	=	$\text{Sin.} \times \text{Cotan.}$
“	=	$\sqrt{1 - \text{Sin.}^2}$
Tangent	=	$1 \div \text{Cotan.}$
“	=	$\text{Sin.} \div \text{Cosin.}$
Cotangent	=	$1 \div \text{Tan.}$
“	=	$\text{Cosin.} \div \text{Sin.}$
Secant	=	$1 \div \text{Cosin.}$
“	=	$\sqrt{1 + \text{Tan.}^2}$
Cosecant	=	$1 \div \text{Sin.}$
“	=	$\sqrt{1 + \text{Cotan.}^2}$
Versine	=	$\text{Rad.} - \text{Cosin.}$
Coversine	=	$\text{Rad.} - \text{Sin.}$
Complement	=	$90^\circ - \text{Angle.}$
Supplement	=	$180^\circ - \text{Angle.}$

If radius of an arc of any angle is multiplied or divided by any given number, then its several correspondent trigonometrical functions are increased or diminished in like ratio.

Diameter	=	$\text{Rad.} \times 2.$
Circumference	=	$\text{Rad.} \times 6.2832.$
“	=	$\text{Diam.} \times 3.1416.$
Area of circle	=	$\text{Diam.}^2 \times .7854.$
Surface of a sphere	=	$\text{Diam.}^2 \times 3.1416.$
Volume of a sphere	=	$\text{Diam.}^3 \times .5236.$

Length of one second of arc = $\text{Rad.} \times .0000048.$

“ “ “ minute “ “ = $\text{Rad.} \times .0002909.$

“ “ “ degree “ “ = $\text{Rad.} \times .0174533.$

VALUES* OF SINES, TANGENTS, ETC., WHEN RADIUS = 1.

Deg.	Sine.	Cover.	Cosec.	Tang't.	Cotan.	Secant.	Versine.	Cosine.	Deg.
0	.00	1.00000	Infinite.	.0	Infinite.	1.00000	0.	1.00000	90
1	.01745	.98254	57.28986	.01745	57.2899	1.00015	.0001	.99984	89
2	.03480	.96510	28.6537	.03492	28.6362	1.00060	.0006	.99939	88
3	.05234	.94766	19.1073	.05241	19.0811	1.00137	.0013	.99863	87
4	.06976	.93024	14.3355	.06993	14.3007	1.00244	.0024	.99756	86
5	.08716	.91284	11.4737	.08749	11.4300	1.00381	.0038	.99619	85
6	.10453	.89547	9.5667	.10510	9.5144	1.00550	.0054	.99462	84
7	.12187	.87813	8.2055	.12278	8.1443	1.00750	.0074	.99255	83
8	.13917	.86082	7.1852	.14054	7.1154	1.00982	.0097	.99027	82
9	.15643	.84356	6.3924	.15838	6.3137	1.01246	.0123	.98769	81
10	.17365	.82635	5.7587	.17633	5.6712	1.01542	.0151	.98481	80
11	.19081	.80919	5.2408	.19438	5.1446	1.01871	.0183	.98163	79
12	.20791	.79208	4.8097	.21255	4.7046	1.02234	.0218	.97815	78
13	.22495	.77504	4.4454	.23087	4.3315	1.02630	.0256	.97437	77
14	.24192	.75807	4.1335	.24933	4.0108	1.03061	.0297	.97030	76
15	.25882	.74118	3.8637	.26795	3.7320	1.03527	.0340	.96593	75
16	.27554	.72436	3.6279	.28674	3.4874	1.04029	.0387	.96126	74
17	.29237	.70762	3.4203	.30573	3.2708	1.04569	.0436	.95630	73
18	.30922	.69098	3.2360	.32492	3.0777	1.05146	.0489	.95106	72
19	.32557	.67443	3.0715	.34433	2.9042	1.05762	.0544	.94552	71
20	.34202	.65797	2.9238	.36397	2.7475	1.06417	.0603	.93969	70
21	.35837	.64163	2.7904	.38386	2.6051	1.07114	.0664	.93358	69
22	.37451	.62539	2.6694	.40403	2.4751	1.07853	.0728	.92718	68
23	.39073	.60926	2.5593	.42447	2.3558	1.08636	.0794	.92050	67
24	.40674	.59326	2.4585	.44523	2.2460	1.09463	.0864	.91355	66
25	.42252	.57738	2.3662	.46631	2.1445	1.10337	.0936	.90630	65
26	.43837	.56162	2.2811	.48773	2.0503	1.11260	.1012	.89879	64
27	.45399	.54600	2.2026	.50952	1.9626	1.12232	.1089	.89101	63
28	.46947	.53052	2.1300	.53171	1.8807	1.13257	.1170	.88295	62
29	.48481	.51519	2.0626	.55431	1.8040	1.14335	.1253	.87462	61
30	.50000	.50000	2.0000	.57735	1.7320	1.15470	.1339	.86603	60
31	.51504	.48496	1.9416	.60086	1.6643	1.16663	.1428	.85717	59
32	.52992	.47008	1.8870	.62487	1.6003	1.17917	.1519	.84805	58
33	.54464	.45536	1.8360	.64941	1.5398	1.19236	.1613	.83867	57
34	.55919	.44080	1.7882	.67451	1.4826	1.20621	.1709	.82904	56
35	.57358	.42642	1.7434	.70020	1.4281	1.22077	.1808	.81915	55
36	.58778	.41221	1.7013	.72654	1.3764	1.23606	.1909	.80902	54
37	.60181	.39818	1.6616	.75355	1.3270	1.25213	.2013	.79864	53
38	.61566	.38433	1.6242	.78128	1.2799	1.26901	.2111	.78801	52
39	.62932	.37067	1.5890	.80978	1.2349	1.28675	.2228	.77715	51
40	.64279	.35721	1.5557	.83970	1.1918	1.30540	.2339	.76604	50
41	.65606	.34394	1.5242	.86929	1.1504	1.32501	.2452	.75471	49
42	.66913	.33086	1.4944	.90040	1.1106	1.34563	.2568	.74314	48
43	.68200	.31800	1.4662	.93251	1.0724	1.36732	.2686	.73135	47
44	.69465	.30534	1.4395	.96569	1.0355	1.39016	.2808	.71934	46
45	.70711	.29289	1.4142	1.	1.	1.41421	.2928	.70711	45
	Cosine.	Versine.	Secant.	Cotan.	Tang't.	Cosec.	Cover.	Sine.	

* When the angle exceeds 45°, read upward; the number of degrees will then be found in the right-hand column, and the names of columns at the bottom.

IN RIGHT-ANGLED TRIANGLES.

$$\begin{aligned} \text{Base} &= \sqrt{\text{Hyp}^2 - \text{Perp}^2}. \\ \text{"} &= \sqrt{(\text{Hyp.} + \text{Perp.}) \times (\text{Hyp.} - \text{Perp.})} \\ \text{Perpendicular} &= \sqrt{\text{Hyp.}^2 - \text{Base}^2}. \\ \text{"} &= \sqrt{(\text{Hyp.} + \text{Base}) \times (\text{Hyp.} - \text{Base.})} \\ \text{Hypothenuse} &= \sqrt{\text{Base}^2 + \text{Perp}^2}. \end{aligned}$$

What constitutes a car load (20,000 lbs. weight) :

70 bbls. lime ; 70 bbls. cement ; 90 bbls. flour ; 6 cords of hard wood ; 7 cords of soft wood ; 18 to 20 head of cattle ; 9000 feet board measure of plank or joists ; 17,000 feet siding ; 13,000 feet of flooring ; 40,000 shingles ; 340 bushels of wheat ; 360 bushels of corn ; 680 bushels of oats ; 360 bushels of Irish potatoes ; 121 cu. ft. of granite ; 133 cu. ft. sandstone ; 6000 bricks ; 6 perch rubble stone ; 10 tons of coal ; 10 tons of cast-iron pipes or special castings.

Lubricator, for slushing heavy gears :

10 gallons, or $3\frac{1}{2}$ pails of tallow ; 1 gallon, or $\frac{1}{3}$ pail of Neat's foot-oil ; 1 quart of black-lead. Melt the tallow, and as it cools, stir in the other ingredients.

For cleaning brass :

Use a mixture of one ounce of muriatic acid and one-half pint of water. Clean with a brush ; dry with a piece of linen ; and polish with fine wash leather and prepared hartshorn.

Iron cement, for repairing cracks in castings :

Mix $\frac{1}{4}$ lb. of flour of sulphur and $\frac{1}{4}$ lb. of powdered sal ammoniac with 25 lbs. of clean dry and fine iron-borings, then moisten to a paste with water and mix thoroughly.

Calk the cement into the joint from both sides until the crack is entirely filled. In heavy castings to be subjected to a great pressure of water, a groove may be cut along a transverse crack, on the side next the pressure, about one-quarter inch deep, with a chisel $\frac{3}{32}$ -inch wide, to facilitate the calking in of the cement.

Alloys.—The chemical equivalents of copper, tin, zinc, and lead bear to each other the following proportions, according to *Rankine* :

Copper.	Tin.	Zinc.	Lead.
31.5	59.	32.5	103.5

When these metals are united in alloys their atomic proportions should be maintained in multiples of their respective proportional numbers; otherwise the mixture will lack uniformity and appear mottled in the fracture, and its irregular masses will differ in expansibility and elasticity, and tend to disintegration under the influence of heat and motion.

MATERIALS.	COMPOSITION.			
	By Equivalents.		By Weight.	
	Copper.	Tin.	Copper.	Tin.
Very hard bronze.....	12	1	6.401	1
Hard bronze, for machinery bearings.....	14	1	6.966	1
Bronze or gun-metal, contracts $\frac{1}{180}$ in cooling	16	1	8.542	1
Bronze, somewhat softer	18	1	9.610	1
Soft bronze, for toothed wheels.....	20	1	10.678	1
	Copper.	Zinc.	Copper.	Zinc.
Malleable brass.....	4	1	3.877	1
Ordinary brass, contracts $\frac{1}{80}$ in cooling.....	2	1	1.938	1
Yellow metal, for sheathing ships.....	3	2	1.454	1
Spelter solder, for brazing copper and iron..	4	3	1.292	1

Babbitt's metal consists of 50 parts of tin, 1 of copper, and 5 of antimony.

Aluminum bronze, containing 95 to 90 parts of copper and 5 to 10 parts of aluminum, is an alloy much stronger than common bronze, and has a tenacity of about 22.6 tons per square inch, while the tenacity of common bronze, or gun-metal, is but about 16 tons.

Manganese bronze is made by incorporating a small proportion of manganese with common bronze. This alloy can be cast, and also can be forged at a red-heat.

A specimen cast at the Royal Gun Factory, Woolwich, in 1876, showed an ultimate strength of 24.3 tons per square inch, an elastic limit of 14 tons, and an elongation of 8.75 per cent. The same quality forged had an ultimate resistance of 29 tons per square inch, an elastic limit of 12 tons, and an elongation of 31.8 per cent. A still harder forged specimen had an ultimate strength of 30.3 tons per square inch, elastic limit of 12 tons, and elongation of 20.75 per cent.

The tough alloy, introduced by Mr. M. P. Parsons, will prove a desirable substitute for the common bronze in hydraulic apparatus, where its superior strength and greater reliability will be especially valuable.

APPROXIMATE BOTTOM VELOCITIES OF FLOW IN CHANNELS AT WHICH THE FOLLOWING MATERIALS BEGIN TO MOVE.

0.25	feet per second,	microscopic sand and clay.
.50	“ “ “	fine sand.
1.00	“ “ “	coarse sand.
1.75	“ “ “	pea gravel.
3	“ “ “	smooth nut gravel.
4	“ “ “	1½-inch pebbles.
5	“ “ “	2-inch square brick-bats.

TENSILE STRENGTH OF CEMENTS AND CEMENT MORTARS, WHEN 7 DAYS OLD, 6 OF WHICH THE CEMENTS WERE IN WATER.

(Compiled from Gilmore.*)

HOW MIXED.	BY WEIGHT.			BY VOLUME, LOOSELY MEASUR'D			BY VOLUME, WELL SHAKEN.			Tensile strength per square inch.	Crushing wt. per sq. in. } Blocks } 3.5 in. wide, 5.5 in. long, 3.0 in. thick.
	Portland Cement	Rosendale Cement.	Sand.	Portland Cement } Weight per U. S. bu., loosely measured, 120 lbs.	Rosendale Cement } Weight per U. S. bu., loosely measured, 56 lbs.	Sand.	Portland Cement.	Rosendale Cement.	Sand.		
Like béton aggloméré.	I	—	.25	I	—	.21	I	—	.25	Lbs.	Lbs.
“ common mortar.	I	—	.25	I	—	“	I	—	“	377	—
“ béton aggloméré.	I	—	.5	I	—	.42	I	—	.5	289	—
“ common mortar.	I	—	.5	I	—	“	I	—	“	320	—
“ béton aggloméré.	I	I	—	I	—	.85	I	—	.99	222	—
“ common mortar.	I	I	—	I	—	“	I	—	“	244	—
“ béton aggloméré.	I	—	1.33	I	—	1.13	I	—	1.3	197	—
“ common mortar.	I	—	1.33	I	—	“	I	—	“	179	—
“ béton aggloméré.	I	—	2	I	—	1.7	I	—	1.9	129	—
“ common mortar.	I	—	2	I	—	“	I	—	“	138	2804.4
“ béton aggloméré.	I	—	6	I	—	5	I	—	5.9	109	1038.0
“ common mortar.	I	—	6	I	—	“	I	—	“	66	259.5
“ béton aggloméré.	I	—	8	I	—	6.8	I	—	7.8	35	—
“ common mortar.	I	—	8	I	—	“	I	—	“	39	259.5
“ béton aggloméré.	I	8	—	I	—	11.6	I	—	—	24	104.7
“ common mortar.	I	8	—	I	—	“	I	—	—	96	—
“ béton aggloméré.	I	2	—	I	—	2.9	I	—	—	40	—
“ common mortar.	I	2	—	I	—	“	I	—	—	129	—
“ béton aggloméré.	—	I	1	—	—	—	—	—	—	44	—
“ common mortar.	—	I	2	—	—	—	—	—	—	51	—
“ “ “	—	I	3	—	I	1.2	—	I	1.4	40	310.7
“ “ “	—	I	4	—	I	1.8	—	I	2	33	116.4
“ “ “	—	I	3	—	I	2.4	—	I	2.8	22	156.0
“ “ “	—	I	6	—	I	3.6	—	I	4	Less than 10 lbs.	52.4
“ “ “	—	I	8	—	—	—	—	—	—	—	46.5
“ “ “	—	I	—	—	—	—	—	—	—	400	2846.7
“ common mortar.	—	I	—	—	—	—	—	—	—	—	2579.2
“ béton aggloméré.	—	I	—	—	—	—	—	—	—	—	727.3
“ common mortar.	—	I	—	—	—	—	—	—	—	—	104.7

* Vide Treatise on Coignet Béton, p. 28, et seq. New York, 1871.

STANDARD DIMENSIONS OF BOLTS, WITH HEXAGONAL HEADS
AND NUTS.

Diameter of bolt in inches.	No. of V threads per in. of length.	Breadth of head. in inches.	Thickn'ss of head in inches.	Breadth of nut in inches.	Thickness of nut in inches.	Weight of round rod per foot in pounds.	Weight of head and nut in pounds.
$\frac{1}{4}$	20	$\frac{3}{8}$	$\frac{1}{4}$	$\frac{3}{8}$	$\frac{5}{16}$.1653	.017
$\frac{5}{16}$	18	$\frac{1}{2}$	$\frac{5}{16}$	$\frac{1}{2}$	$\frac{3}{8}$.2583	.033
$\frac{3}{8}$	16	$\frac{5}{8}$	$\frac{3}{8}$	$\frac{5}{8}$	$\frac{7}{16}$.3720	.057
$\frac{7}{16}$	14	$\frac{11}{16}$	$\frac{7}{16}$	$\frac{11}{16}$	$\frac{1}{2}$.5063	.087
$\frac{1}{2}$	13	$\frac{3}{4}$	$\frac{1}{2}$	$\frac{3}{4}$	$\frac{9}{16}$.6613	.128
$\frac{9}{16}$	12	$\frac{7}{8}$	$\frac{9}{16}$	$\frac{7}{8}$	$\frac{5}{8}$.8370	.190
$\frac{5}{8}$	11	1	$\frac{5}{8}$	1	$\frac{11}{16}$	1.033	.267
$\frac{3}{4}$	10	$1\frac{1}{8}$	$\frac{3}{4}$	$1\frac{1}{8}$	$\frac{13}{16}$	1.488	.43
$\frac{7}{8}$	9	$1\frac{3}{8}$	$\frac{7}{8}$	$1\frac{3}{8}$	$\frac{15}{16}$	2.025	.73
1	8	$1\frac{1}{2}$	1	$1\frac{1}{2}$	$1\frac{1}{16}$	2.645	1.10
$1\frac{1}{8}$	7	$1\frac{3}{4}$	$1\frac{1}{8}$	$1\frac{3}{4}$	$1\frac{3}{16}$	3.348	1.60
$1\frac{1}{4}$	7	$1\frac{7}{8}$	$1\frac{1}{4}$	$1\frac{7}{8}$	$1\frac{5}{16}$	4.133	2.14
$1\frac{3}{8}$	6	$2\frac{1}{8}$	$1\frac{3}{8}$	$2\frac{1}{8}$	$1\frac{7}{16}$	5.001	2.95
$1\frac{1}{2}$	6	$2\frac{1}{4}$	$1\frac{1}{2}$	$2\frac{1}{4}$	$1\frac{9}{16}$	5.952	3.78
$1\frac{5}{8}$	$5\frac{1}{2}$	$2\frac{1}{2}$	$1\frac{5}{8}$	$2\frac{1}{2}$	$1\frac{11}{16}$	6.985	4.70
$1\frac{3}{4}$	5	$2\frac{5}{8}$	$1\frac{3}{4}$	$2\frac{5}{8}$	$1\frac{13}{16}$	8.101	5.60
$1\frac{7}{8}$	5	$2\frac{7}{8}$	$1\frac{7}{8}$	$2\frac{7}{8}$	$1\frac{15}{16}$	9.300	7.00
2	$4\frac{1}{2}$	3	2	3	$2\frac{1}{16}$	10.58	8.75
$2\frac{1}{4}$	$4\frac{1}{2}$	$3\frac{3}{8}$	$2\frac{1}{4}$	$3\frac{3}{8}$	$2\frac{5}{16}$	13.39	12.40
$2\frac{1}{2}$	4	$3\frac{3}{4}$	$2\frac{1}{2}$	$3\frac{3}{4}$	$2\frac{9}{16}$	16.53	17.00
$2\frac{3}{4}$	4	$4\frac{1}{8}$	$2\frac{3}{4}$	$4\frac{1}{8}$	$2\frac{13}{16}$	20.01	22.30
3	$3\frac{1}{2}$	$4\frac{1}{2}$	3	$4\frac{1}{2}$	$3\frac{1}{16}$	23.81	28.80

WEIGHTS OF LEAD AND TIN LINED SERVICE-PIPES.

Calibre.	AAA. Weight per ft.	AA Weight per ft.	A. Weight per ft.	B. Weight per ft.	C. Weight per ft.	D. Weight per ft.	D. Light. Weight per ft.	E. Weight per ft.	E. Light. Weight per ft.
<i>Inches.</i>	<i>Lbs.</i>	<i>Lbs.</i>	<i>Lbs.</i>	<i>Lbs.</i>	<i>Lbs.</i>	<i>Lbs.</i>	<i>Lbs.</i>	<i>Lbs.</i>	<i>Lbs.</i>
$\frac{3}{8}$	1.5	1.3	1.12	1	1.06	0.62	—	0.5	—
$\frac{1}{2}$	3	2	1.75	1.25	1	0.81	—	0.7	0.56
$\frac{5}{8}$	3.5	2.75	2.5	2	1.75	1.5	1.25	1	0.75
$\frac{3}{4}$	4.5	3.5	3	2.25	2	1.75	1.5	1.25	1
1	6	4.75	4	3.25	2.5	2	—	1.5	—
$1\frac{1}{4}$	6.75	5.75	4.75	3.75	3	2.5	—	2	—
$1\frac{1}{2}$	9	8	6.25	5	4.25	3.5	—	3.25	—
2	10.75	9	7	6	5.25	4	—	—	—

A manufacturer's circular states that the following quantities of water will be delivered through 500 feet of their pipes, of the respective sizes named, when the fall is ten feet :

Calibre	$\frac{3}{8}$ inch.	$\frac{1}{2}$ inch.	$\frac{5}{8}$ inch.	$\frac{3}{4}$ inch.	1 inch.	$1\frac{1}{4}$ inch.
Gallons per minute...	.348	.798	1.416	2.222	4.600	6.944
Gallons per 24 hours..	576	1150	2040	3200	6624	10000

A $\frac{3}{4}$ -inch clean service-pipe connected to a $\frac{1}{2}$ -inch tap under a hundred feet head, will deliver at the sink, through a common compression bib, ordinarily about three pails of water, or say 8.25 gallons, or 1.1 cu. ft. of water per minute.

Lead is more generally used for service-pipes than any other material, but wrought-iron pipe, lined and coated with cement, or with a vulcanized rubber composition or sundry coal-tar compositions and enamels, have been used to a nearly equal extent within a few years past. Block-tin pipe, tin-lined pipe, and galvanized iron pipe, have been used also to a limited extent.

Lead pipes of weights as in class A are used ordinarily when the head of water on them does not exceed 75 feet; class AA when the head is from 75 to 150 feet; and class AAA when the head, or strain from water-ram, is great.

The strain from water-ram, in service-pipes, is very much dependent on the character of the plumbing with which the services connect.

METERS AND METER RATES, 1875.

CITY.	N ^o . of Meters used.	Rate per 100 cu. ft. Cents.	Kind of Meters.	Furnished by*
Boston, Mass.	974	22½	W.	Water-works.
Baltimore, Md.	320	20	W.	Water-works.
Bridgeport, Conn.	1	26½ to 40	W.	Water-works.
Charlestown, Mass.	180	22½	W.—B. & F.	Water-works.
Chicago, Ill.	1050	13½	W.	Water-works.
Cleveland, O.	18	13½ to 21½	W.—B. & F.	Water-works.
Columbus, O.	138	26½	B. & F.—E.—Nav.	Consumer.
Fitchburg, Mass.	25	11¼ to 37½	B. & F.	Consumer.
Fall River, "	4	22½	B. & F.	Consumer.
Hartford, Conn.	6	15 to 22½	B. & F.—D.	Water-works.
Jersey City, N. J.	208	26½	W.	Water-works.
Louisville, Ky.	119	20	W.	Water-works.
Meriden, Conn.	9	26½ to 40	B. & F.	Water-works.
Manchester, N. H.	160	15 to 30	B. & F.—N.	Water-works.
New York, N. Y.	200	12	W.	Consumer.
New London, Conn.	20	26½	N.	Water-works.
New Haven, "	3	22½	N.	Consumer.
New Bedford, Mass.	3	B. & F.	Water-works.
Providence, R. I.	1358	22½	B. & F.—W.	Consumer.
Portland, Me.	22½ to 37½	B. & F.—W.	Consumer.
Springfield, Mass.	8	22½	W. & B. & F.	Water-works.
St. Paul, Minn.	40	40 to 64½	B. & F.—N.	Water-works.
San Francisco, Cal.	800	64½ to 133	W.	Water-works.
Waterbury, Conn.	8	26½ to 40	W.—B. & F.	Water-works.
Worcester, Mass.	800	11¼ to 18¾	B. & F.	Water-works.

The initials refer to kinds of meters, as follows :

W.—Worthington.

B. & F.—Ball & Fitts.

N.—National Meter Co. (Gem.)

E.—Eagle.

Nav.—Navarro.

D.—Desper.

* A common practice is, for the water-works to furnish the meter and maintain and control it, and to charge the consumer from ten to fifteen per cent. on its original cost, annually, to cover the expense, in addition to the regular meter rate for water consumed.

RESUSCITATION FROM DEATH BY DROWNING.

Persons may be restored from apparent death by drowning, if proper means are employed, sometimes when they have been under water, and are apparently dead, for fifteen or even thirty minutes. To this end—

1. Treat the patient INSTANTLY, on the spot, in the open air, freely exposing the face, neck, and chest to the breeze, except in severe weather.

2. Send with all speed for medical aid, and for articles of clothing, blankets, etc.

I. TO CLEAR THE THROAT.

3. Place the patient gently on the face, with one wrist under the forehead.

(All fluids, and the tongue itself, then fall forwards, and leave the entrance into the windpipe free.

II. TO EXCITE RESPIRATION.

4. Turn the patient slightly on his side, and

(I.) Apply snuff, or other irritant, to the nostrils; and

(II.) Dash cold water on the face, previously rubbed briskly until it is warm.

If there be no success, lose no time, but

III. TO IMITATE RESPIRATION.

5. Replace the patient on the face.

6. Turn the body gently but completely on the side, and a little beyond, and then on the face alternately, repeating these measures DELIBERATELY, EFFICIENTLY, and PERSEVERINGLY, fifteen times in the minute only.

(When the patient reposes on the chest, this cavity is

compressed by the weight of the body, and EXPIRATION takes place ; when it is turned on the side, this pressure is removed, and INSPIRATION occurs.)

7. When the prone position is resumed, make equable but efficient pressure along the spine, removing it immediately before rotation on the side.

(The first measure augments the EXPIRATION, and the second commences INSPIRATION.)

IV. TO INDUCE CIRCULATION AND WARMTH, CONTINUE THESE MEASURES.

8. Rub the limbs upwards, with FIRM PRESSURE and ENERGY, using handkerchiefs, etc.

9. Replace the patient's wet covering by such other covering as can be instantly procured, each bystander supplying a coat or a waistcoat. Meantime, and from time to time,

V. AGAIN, TO EXCITE INSPIRATION,.

10. Let the surface of the body be slapped briskly with the hand ; or

11. Let cold water be dashed briskly on the surface, previously rubbed dry and warm.

Avoid all rough usage. Never hold up the body by the feet. Do not roll the body on casks. Do not rub the body with salts or spirits. Do not inject smoke or infusion of tobacco, though clysters of spirits and water may be used.

The means employed should be persisted in for several hours, till there are signs of death.

I N D E X.

 *The figures refer to the pages.*

A.

Acceleration of motion, 185.
 Adjustable effluent pipe, 364.
 Advantages of water supplies, 29.
 Air, resistance of, to a jet, 190.
 " valves, 523.
 " vessel, 564, 565.
 Ajutage, an, 213.
 " inward projecting, 218.
 " vacuum, 214.
 Algæ, fresh water, 129.
 Analyses of lake, spring, and well waters, 117.
 " " mineral waters, 143.
 " " potable waters, table, 117.
 " " river and brook waters, 118, 120.
 Analysis of impure ice, 136.
 Angular force graphically represented, 175.
 Aquatic life, purifying office of, 132.
 " organisms, 131.
 Arago's prediction at Grenelle, 106.
 Areas of sluice valves, 360.
 Artesian wells, 105, 106, 108.
 " temperature of, table, 127.
 Artificial clarification of water, 159.
 " gathering areas, 100.
 " pollution of water, 152.
 " storage " " 84, 93, 95, 98, 99.
 Asphaltum bath for pipes, 475, 487, 490.
 Atlantic coast rainfall, 53.
 Atomic theory, 162.
 Attraction, capillary, 206.
 Atmospheric impurities of water, 122.
 " pressure, 182.
 Average consumption of water, 44.

B.

Basins, clear-water, 550.
 " infiltration, 537.
 " settling, 550.
 Bends and branches, 272, 275, 478, 485.
 " coefficients for, table of, 274.
 Blow-off valves, 513.
 Boilers, 577, 578, 580.
 Bolts in flanges, table of, 462.
 Bolt-holes, templet for, 460.
 Boyden's hook-gauge, 297.
 Branches and bends, 272, 478, 484.
 " composite pipe, 484.
 " formula for flow through, 275.
 Bucket-plunger pump, 557, 567.
 Bursting pressure, 232.

C.

Caloric, influence of, 163.
 Canal banks, 370.
 " in side hill, 370.
 " miner's, 375.
 " open, 370.

Canal revetments and pavings, 371.
 " slopes, 371.
 " stop-gates, 373.
 Canals and rivers, observed flows in, table of, 307.
 Canals and rivers, coefficients for flow in, 308.
 Capacity for filter-beds, 552.
 Capillary attraction, 296.
 Cast-iron pipes, 451.
 " weights of, 465, 468, 469.
 Cast socket on wrought pipe, 483.
 Casting of pipes, 452.
 Cement joints of pipes, 482.
 " lined pipes, 479.
 " lining of pipes with, 481.
 " mortar, for lining and covering pipes, 487.
 Census statistics, 31.
 Central rain system, 49.
 Chamber, effluent, 358.
 " influent, 366.
 " walls, 369.
 Chandler's, Prof., remarks on wells, 140.
 Channels, coefficients for, 308.
 " depths and relative volumes and velocities, 328.
 " flow in, experimental data, 306.
 " flow in open, 299.
 " formulas for flow, table, 310.
 " inclination in, 304.
 " influences controlling flow in, 316.
 " ratios of surface to mean veloc., 315.
 " surface velocities, 313.
 " velocity of flow in, 303, 304.
 " velocities of given films, 311.
 " water supply, protection of, 431.
 Characteristics of pipe metals, 470.
 Charcoal clarification of water, 535, 537.
 " filters, 536.
 Check-valve, 367, 525.
 Chemical clarification, 532.
 Choice of water, 587.
 Cities, families in various, 32.
 " persons per family in various, 32.
 " population of various, 32.
 " water supplied to, 35, 36, 37.
 Clarification of water, artificial, 159, 532.
 " " " charcoal, 535, 537.
 " " " chemical, 532.
 " " " natural, 149, 530, 532.
 Cleaning of filter-beds, 553.
 Clear water basin, 550.
 Climate effects, rainfall, 47.
 Coal required for pumping, 581.
 Coating (asphaltum) pipes, 475, 487, 490.
 Cochituate basin, rain upon, 72.
 Coefficients, compound tubes, 219, 220.
 " convergent tubes, 217.
 " c', table of, 271.
 " experimental, 198.
 " " table of, 237.

- Coefficients for channels, Kutter's, 305.**
 " " circular orifices, 203.
 " " flow in conduits, 444.
 " " hydrometers, 325.
 " " pipes, table of, 242.
 " " rectangular orifices, 205, 206.
 " " service-pipes, 528.
 " " weir formulas, 287, 288.
 " " wide-crested weirs, 294.
 " from Castel, 200.
 " " Eytelwein and D'Aubuis-
 son, 256.
 " " General Ellis, 201.
 " " L'Abbe Bossut, 199.
 " " Lespinasse, 201.
 " " Michelotti, 198.
 " " Prony, 255.
 " " Rennie, 199.
 " increase of, in short tubes, 213.
 " m, 234, 247.
 " mean, for smooth and foul pipes,
 248, 249, 267.
 " of efflux, factors of, 197, 208.
 " " table of, 227.
 " " entrance of jet, 267.
 " " flow for channels, 305, 308.
 " " friction of earth-work, 345.
 " " " table of, 495.
 " " issue from short tubes, 218.
 " " masonry frictions, 396.
 " " velocity and contraction for
 orifice jets, 208.
 " practical application of, 197.
 " range of, 222.
 " resistance in bends, 274.
 " variable values of, 210.
Coffer-dams, 430.
Combined reservoir and direct systems, 525.
Commercial use of water, 34.
Compensation flow, 86.
 " to riparian owners, 94.
Composite branches, pipe, 484.
Composition of water, the, 112.
Compound tubes, 218, 220.
 " " coefficients for, 220.
Compressibility and elasticity of water, 167.
Concrete conduit, a 438.
 " foundations, 368.
 " foundations for pipes, 487.
 " paving, 355.
 " proportions of, 368.
 " revetments, 429.
Conduit arch, thrust of, 437.
 " data, 445.
 " masonry to be self-sustaining, 437.
 " of concrete, 438.
 " of wood, 439, 441.
 " shells, 434.
Conduits and pipes, 223.
 " backing of, 438.
 " coefficients for, 444.
 " examples of, 431, 438, 439.
 " exposure to frost, 437.
 " formulas for flow in, 442, 443.
 " foundations for, 433.
 " locked bricks for, 435.
 " masonry, 431.
 " mean radii of, 441, 442.
 " protection from frost, 436.
 " stop-gates in, 436.
 " transmission of pressure in, 436.
 " under pressure, 435, 439.
 " ventilation of, 434.
Confervæ, 129.
Construction of embankments, 348.
 " of filter-beds, 548.
Consumption of water, 34, 43, 503.
Core of an embankment, 348.
Cornish pump, 557, 563.
Costs of pumping water, 574, 575.
Crib-work foundations, 385.
 " weir, 384.
Croton basin, rainfall upon, 72.
Curbs, stop-valve, 515.
Curved-face wall, 421.
Cut-off wall, embankment, 348.
Cycle, low, rainfalls, 69, 77, 78.
Cylindrical penstock, 440.
 " tubes, 222.
D:
Dams, thickness of, 387.
Darcy-Pitot tube gauge, 322.
Data from existing conduits, 445.
Débris, floating, 530.
Decimal parts of an inch and foot, 457.
Decomposing organic impurities, 127.
Densities and volumes of water, relative, 164.
Desmids, in fresh ponds, 129.
Details of stop-valves, 513.
Depths of pipes, 501, 502.
Diagonal force, 175.
Diagrams of pumping, 42.
 " of rainfall, 55, 57, 59.
Diameter of sub-mains, 507.
 " of supply-main, 506.
Dimensions of existing canals, 373.
 " " filter-beds, 554.
 " " retaining walls, 420.
Direct pressure system, 590.
Discharges of pipes, 498, 500.
 " over waste-weirs, 378, 381.
Domestic draught of water, 34, 508.
Draught, variations in, 41.
Duplicate pumping machinery, 590.
Duplication in pipe systems, 510.
Duty of pumping-engines, 574, 576, 580, 583.
Dwellings in various cities, 32.
Dykes, canal and river, 371.
E:
Earth and rock, porosity of, 102.
 " embankments, 333, 347, 348, 353, 370-
 " evaporation from, 89, 90.
 " pressures against walls, 408.
Eastern coast rain system, 50.
Economy of high duty of pumping-engines,
 " " skillful workmanship, 369.
Eddies, in weir channels, 292.
Effect, mechanical, of the efflux, 225.
Effluent chambers, 358.
 " " ice-thrust upon, 358.
Efflux, equation of, 211.
 " factors of the coefficient, 197.
 " from pipes, coefficients of, 196, 227.
 " mechanical effect of, 225.
 " peculiarities of jet, 207.
 " volume from short tubes, 194, 210, 214.
Elasticity and compressibility of water, 167.
Electric moulinet, Henry's, 326.
Elementary dimensions of pipes, 504.
Elements, the vapory, 45.
Embankment, a light, 353.
 " core materials, 339, 342, 348, 354-
 " cut-off walls, 336, 338, 348.
 " example of, 347.
 " failures, 334.
 " fine sand in, 353.
 " foundations, 335.
 " frost covering, 350.
 " gate chambers, 357, 358.
 " masonry-faced, 354.
 " materials, coeffs. of friction, 345.
 " " frictional angle of,
 345.

Embankment materials, proportions of, 340.
 " " weights of, 341.
 " pressures in, 343.
 " puddle wall, 351.
 " puddled slopes, 356.
 " sheet-piling under, 339.
 " site, reconnaissance for, 347.
 " slope-paving, 350.
 " slopes, 344, 345, 350.
 " sluices, 355, 356, 358.
 " soils beneath, 337.
 " springs under foundation, 337.
 " substructure, 336.
 " siphon waste-pipe, 358.
 " test borings at site, 336.
 " treacherous strata under, 338.
 Embankments, canal, 370.
 " Indian, 334.
 " reservoir, 333.
 Energy of jet, 276.
 England, supply per capita, 37.
 Equation of motion, 186.
 " " resistance to flow, 233.
 Equilibrium destroyed, 170, 300.
 Errors in application of formulæ, 252, 257.
 " " weir measurements, 296.
 Estimates of flow of streams, 78, 94.
 European infiltration, 544.
 Evaporation, effect upon storage, 93.
 " examples of, 90.
 " from earth, 89, 110.
 " " reservoirs, 94.
 " water, 88, 89.
 " phenomena, 87.
 " ratios of, table, 92.
 Evaporative power of boilers, 578, 580.
 Examples of conduits, 431, 438, 439.
 Experimental channel data, 306.
 " coefficients for hydrometers, 325.
 Experiments with weirs, 284.
 Eytelwein's coefficients, 222.

F.

Faced revetments, 429.
 Failures of embankments, 334.
 " " walls, 427.
 Falling bodies, 190.
 Families in various cities, 32.
 Fascine revetments, 371.
 Filter-beds, 547.
 " capacity of, 552.
 " cleaning of, 553.
 " construction of, 548, 557.
 " ice upon, 556.
 " protection of, 548, 555.
 " temperature of, 555.
 " vegetal growth in, 555.
 Filters, Atkin's, 536.
 Fire draught of water, 34, 506, 508.
 " extinguishment, reserve for, 44.
 " hydrants, 516, 519, 521.
 " losses, effect of water upon, 26.
 " service, 493, 588, 589, 591.
 " " head desirable for, 493.
 " supplies, diameters of pipes for, 510.
 Fish screens, 365.
 Flanges, diameters of valve, 462.
 " of cast-iron pipes, 462.
 Flash-boards, 378.
 Flashy and steady streams, 71.
 Flexible pipe-joints, 463.
 Floats, double, gauge, 326.
 " maximum velocity, 328.
 " mid-depth, 326.
 Flood flow, 65, 98.
 " volumes, 65, 67, 381.
 Floods, ratios of, to rainfalls, 62.

Floods, seasons of, 68.
 Flow, available, for consumption, 94.
 " coefficients of, 230.
 " compensation, 86.
 " equivalent to given depths of rain, 81.
 " from Croton and Cochituate basins, 73.
 " " different surfaces, 77.
 " gauged volumes of, 277.
 " gravity the cause of, 299.
 " in seasons of minimum rain, 69.
 " increase and decrease of, 86.
 " influence of absorption and evaporation upon, 68.
 " minimum, mean, and flood, 75.
 " of streams and channels, 65, 299.
 " " water, 184.
 " over a weir, 280.
 " periodic available, 69.
 " resistance to, in channels, 232, 300.
 " sub-surface equalizers of, 70.
 " summaries of monthly statistics of, 71.
 " through orifices, 194.
 " " pipes, 223, 508, 560.
 " " short tubes, 213.
 " " sluices, pipes, and channels, 161.
 Fluctuations of streams, 319.
 Flush hydrant, 519, 521.
 Foot and inch, equivalent decimal parts of, 457.
 Force, loss of, in pipes, 224.
 " percussive, of particles, 221.
 Forces, angular, 176.
 " equivalent, 172.
 " graphically represented, 175.
 Formula, efflux from an orifice, 196, 209, 211.
 " " short pipes, 215.
 " for capacity of air-vessel, 566.
 " " coal for pumping, 581.
 " " curved-face walls, 421.
 " " depth upon a weir, 286.
 " " duty of pumping-engines, 576.
 " " earth pressures upon walls, 410,
 " 412, 413, 415, 416.
 " " inclination in channels, 304.
 " " power to produce flow in pipes,
 " 561.
 " " pressure in pipes, 447.
 " " pressure on submerged walls, 393,
 " 394.
 " " resistance in channels, 301, 303.
 " " surcharged pressure walls, 414,
 " 416, 423.
 " " triangular notch weir, 294.
 " " velocity in channels, 303, 304.
 " " volume at given temp., 165.
 " " weights of cast pipes, 465, 467.
 " of M. Chezy, pipes, 252.
 " Weisbach, " 257.
 Formulas, coefficients for weir, 287.
 " for diameters of pipes, 251, 266, 269,
 " 270, 498.
 " " flood volumes, streams, 320.
 " " flow in conduits, 442, 443.
 " " " pipes, 254, 257.
 " " " origin of, 229.
 " " " through bends, 272.
 " " " " branches, 275.
 " " " " channels, 310.
 " " gauging streams, 320.
 " " head, pipes, 250, 266, 268, 270, 494.
 " " lengths of pipes, 269, 270.
 " " pipes, various compared, 254.
 " " resistance to flow, 230, 234, 250.
 " " thickness of pipes, table, 466.
 " " " cast pipes, 453, 454,
 " 466.
 " " " " wrought pipes, 448,
 " 450, 486.
 " " velocity, pipes, 249, 266, 267, 268,
 " 270, 498.

- Formulas for volume, pipes, 250, 254, 266, 498.
 " " weir volumes, 282, 283, 284, 286.
 " " wide-crested weirs, 293.
 " " many incomplete, 252.
 " " misapplication of, 316.
 " " stability of masonry, 395, 397, 398.
 " " velocities and times of falling bodies, 186.
 Foundation, concrete, 386.
 " " embankment, 335.
 " " for pipes, 487.
 " " of gate chambers, 367.
 " " of conduits, 433.
 " " walls, 395, 406, 407.
 " " under water, 430.
 Fountain use of water, 34.
 Francis, Jas. B., experiments with weirs, 284.
 " " tubes, 317.
 Frankland's definition of polluted water, 137.
 Friction, coefficient of masonry, 396.
 " " in pipes, 230, 234, 250, 508.
 " " of ice on canals, 372.
 " " pumping machinery, 578.
 Frictional head, formula for, 494.
 " " in pipes, 493, 494, 527.
 " " stability of masonry, 395.
 Frost curtain, 367.
 " " disintegrates mortar, 436.
 " " protection of conduits from, 436.
 Fuel, expense for pumping, 581.
 " " required " " 575.
 Fungi, microscopic, 129.

G.
 Galleries, infiltration, 539, 540.
 Gate chambers, 357, 367.
 " " hydrants, 522.
 Gates, stop, canals, 374.
 Gauge, Darcy-Pitot tube, 322.
 " " Darcy's double tube, 322.
 " " double float, 326.
 " " formulas, 319.
 " " hook, Boyden's, 296, 297.
 " " maximum velocity float, 328.
 " " mid-depth float, 326.
 " " Pitot tube, 320.
 " " rain, 63.
 " " rule, for weirs, 298.
 " " tube, 317.
 " " tube and scale, weirs, 298.
 " " Woltman's, 322.
 Gauges and weights of plate iron, 487, 488.
 Gauging, hydrometer, 316.
 " " of mountain streams, 296.
 " " rainfall, 62.
 " " rivers, 318, 319.
 Gears for sluice-gates, 359.
 General rainfall, 46.
 Geological science, application, 106.
 Granular stability of masonry, 402.
 Graphical representation of force, 175.
 Gravitation system, 588.
 Gravity, 185, 230, 299.
 " " centre of, 177.
 Great rain-storms, 61.
 Grouped rainfall statistics, 52.
 Grouting, 353, 369.

H.
 Hardening impurities, 125.
 Hardness of water, 125.
 Head, desirable for fire service, 493.
 " " effective in pipe system, 493.
 " " how to economize, 276.
 " " loss by friction, 493.
 " " subdivisions of, 225.
 " " value of, 493.
 Heat, units of, utilized, 578.

 Heights of waves, 388.
 Heisch's sugar test of water, 159.
 Helpful influence of water supplies, 27.
 Hook gauge, Boyden's, 296.
 Hook gauge, use to detect fluctuations, 319.
 Horse-power, to produce flow, 561.
 Hose streams, 510, 520.
 " " use of water, 34.
 Hudson valley, rainfall in, 53.
 Hydrants, 516, 517, 519, 522.
 " " high pressures, 522.
 " " streams, 520.
 Hydraulic mean depth, 235.
 " " radius, 236.
 " " power pumping, 589, 591.
 " " proof of pipes, 477.
 Hydrometers, Castells' and others, 326.
 " " coefficients for, 325.
 " " gauging with, 316.

I.
 Ice covering of canals, 372.
 " " impure, in drinking water, 135.
 " " thrust, 358, 386.
 Impounders, flow to, 86.
 Impounding of water, 144.
 Impregnation of water, 141, 152.
 Impurities of water, 112.
 " " " " agricultural, 134.
 " " " " atmospheric, 122.
 " " " " manufacturing, 134.
 " " " " mineral, 115, 133.
 " " " " organic, 116, 127, 130.
 " " " " sewage, 134.
 " " " " sub-surface, 123.
 " " " " deep wells, 125.
 Inch and foot, decimal parts of, 457.
 Incidental advantages of water supplies, 29.
 Inclination in channels, 235, 304, 371.
 Increase in use of water, 39.
 Indian embankments, 334.
 Indicator, stop-valve, 361.
 Infiltration, 537, 540, 543, 544.
 Influent chamber, 366.
 Infusoria, 130.
 Inhabitant, supply per, 40.
 Intercepting well, 546.
 Interchangeable pipe-joints, 469.
 Introduction of filters, 551.
 Insurance schedule, 29.
 Investment, value of water supplies as an, 29.
 Iron, gauges and weights, 488.
 " " sluice valves, 360.
 " " -work, varnishes for, 474, 476, 489.
 Irrigation canals, 370, 373.
 Isolated weirs, 383.

J.
 Jets, 211, 267.
 Joint mortar for pipes, 487.
 Joints of cast pipes, 457, 461, 463, 469.

K.
 Kutter's coefficients for channels, 305.

L.
 Lake waters, 142.
 Lakes, 150.
 Laying of wrought-pipes, 482.
 Lead, joint, 468.
 Lengths of waste-weirs, 381.
 Level, use of, in gauging, 319.
 Leverage of water pressure, 397.
 " " resistance of walls, 402.
 " " stability of masonry, 397.
 Life of dams, 388.
 Lining of pipes, cement, 481.
 Logarithms of ratios, 121.

- Loss by evaporation, 87.
- “ from reservoirs, 84.
- “ of head by friction, 276, 493.

M.

- Mains and distribution pipes, 446.
- “ power to produce flow in, 561.
- Masonry conduits, 431, 437.
- “ coverings of waste-pipes, 357.
- “ examples of pressure in, 403.
- “ faced embankment, 354.
- “ frictional stability of, 397.
- “ granular stability of, 402.
- “ limiting pressures in, 404.
- “ weight leverage of, 398.
- Materials, embankment, 339, 341.
- Maximum velocities of flow, 508.
- Metals, pipe, 470, 472.
- “ tenacities of wrought, 451, 486, 491.
- Microscopical examination of metals, 471.
- Mineral impurities, 115, 530.
- “ springs, 142, 143.
- Miners' canals, 375.
- Misapplication of formulæ, 316.
- Mississippi valley, rainfall in, 54.
- Molecular theories, 162, 296.
- Molecules, 185.
- Moment of earth leverage, 412.
- Monads, 130.
- Monthly and hourly variations in the draught, 41.
- “ fluctuations in rainfall, 56.
- Mortar for lining and covering pipes, 487.
- Motion, acceleration of, 185.
- “ equations of, 186.
- “ of a piston, 562.
- “ of water, 184, 194.
- “ parabolic of a jet, 187.
- Moulding of pipes, 451.
- Moulinets, 323, 326.
- Municipal control of water supplies, 28.

N.

- Natural clarification, 149, 532.
- “ laws, uniform effects of, 61.
- Necessity of water supplies, 25.
- Noctos, 129.

O.

- Ohio river valley, rainfall in, 54.
- Open canals, 370.
- Ordinary flow of streams, 80.
- Organic impurities, 80, 113, 116, 531, 532.
- Organisms, 129, 131, 133.
- Orifices, classes of, 194.
- “ convergent, 212.
- “ path toward, 194.
- “ cylindrical and divergent, 212.
- “ flow of water through, 194, 210.
- Orifice-jet, form of submerged, 195.
- “ peculiarities, 207.
- “ ratio of minimum section, 195.
- “ variations, 204.
- “ velocity, 196, 208, 209.

P.

- Pacific coast rainfall, 54.
- Parabolic path of jet, 187.
- “ segment, application to weir vol-umes, 282.
- Partitions and retaining walls, 390.
- Paving, concrete, 355.
- “ embankment slope, 350.
- Peculiar watersheds, 71.
- Penstock, cylindrical, wood, 439, 441.
- Percolation from reservoirs, 85, 94.

- Percolation of rain, 104, 111.
- “ under retaining walls, 406.
- Permanence of water supply essential, 585.
- Persons per family, 32.
- Physiological effects of the impurities of water, 114.
- “ office of water, 25.
- Pipe, adjustable effluent, 364.
- “ and conduit, 223.
- “ branches, composite, 484.
- “ joints, cast, 457, 461, 463, 469, 483.
- “ “ hub on wrought, 483.
- “ “ dimensions of, 459, 451, 462.
- “ “ flexible, 463.
- “ “ interchangeable, 469.
- “ metals, 470, 472.
- “ wrought, strength of, 451, 486, 491.
- “ resistance at entrance to, 226.
- “ shells, wrought, thickness of, 448, 485, 486.
- “ systems, duplication in, 510.
- “ “ illustrations, 493, 510.
- “ walls, resistances of, 227, 228.
- Pipes and sluices, embankment, 355.
- “ cast-iron, 451.
- “ “ thickness of, 453, 454, 455, 466.
- “ “ weights of, 465, 468, 469.
- “ cement joints, 482.
- “ lined, 479, 481.
- “ coefficients of friction, 242, 495.
- “ concrete foundations for, 487.
- “ depths of, 501, 502.
- “ “ sockets, 459, 461.
- “ diameters for fire supplies, 510.
- “ elementary dimensions of, 504.
- “ flanges, table of, 462.
- “ formulas for thickness of cast, 453, 466.
- “ “ velocity, head, volume, and diameter, 224, 266, 268, 270, 498.
- “ “ “ weights of cast, 465.
- “ frictions in, 224, 495, 508.
- “ hydraulic proof of, 477.
- “ lead in joints, 468.
- “ mains and distribution, 446.
- “ preservation of surfaces, 473, 480, 489, 491.
- “ relative capacities of, 498, 500.
- “ short, 223.
- “ square roots of fifth powers of diameters, 499, 500.
- “ static pressure in, 446.
- “ sub-coefficients of flow (c'), 271.
- “ temperatures of water in, 502.
- “ thicknesses of wrought, 447, 450, 486, 488.
- “ volumes of flow from, 223, 225, 495.
- “ water-ram in, 448, 449.
- “ wood, 491.
- “ wrought-iron, 479.
- “ plates for, 490.
- Piping and water supplied, 38.
- “ ratio to population, 35.
- Piston motion, 562.
- “ pump, 557, 558.
- Pitot tube gauge, 320.
- Plant and insect agencies, 147.
- “ growth in reservoirs, 145.
- Plates for wrought pipes, 490.
- Plunger pump, 557, 563.
- Pluviometer, 63.
- Polluted water, definition of, 137.
- Polluting liquids, inadmissible, 154.
- Pollution question, 156.
- “ of water, artificial, 152.
- Population, and relation of supply per capita, 40.
- “ of various cities, 32.

- Portland cement for joint mortar, 487.
 Porosity of earths and rocks, 102.
 Post hydrants, 517.
 Power consumed by variable flow in a main,
 560.
 " required to open a valve, 361, 364.
 Practical construction of water-works, 333.
 Precautions for triangular weirs, 295.
 Precipitation, influence of elevation upon, 50.
 Preservation of pipe surfaces, 473, 480, 489, 491.
 Pressure, a line a measure of, 174.
 " conduits under, 435, 439, 440
 " conversion into mechanical effect,
 230.
 " of velocity into, 227.
 " direction of maximum effect, 176.
 " leverage of water, 397.
 " of earth against walls, 408, 410, 413,
 415, 416.
 " " water, 168.
 " " " in a conduit, 437.
 " proportional to depth, 169.
 " sustaining upon floating bodies, 179.
 " transmission of, 183.
 " upon a unit of surface, 171.
 " " surfaces, 391, 393.
 " weight a measure of, 173.
 Pressures, artificial, 171.
 " at given depths, table, 172.
 " atmospheric, 182.
 " centres of, 177.
 " convertible into motion, 184.
 " from inclined columns of water, 170.
 " great in hydrants, 522.
 " horizontal and vertical effects, 177.
 " in embankments, 343.
 " limiting in masonry, 404.
 " static in pipes, 446, 448.
 " total of water, 176.
 " upon circular areas, 179.
 " " curved surfaces, 178.
 " upward upon submerged lintels, 181.
 Prism of weir volumes, 282.
 Processes for preserving iron, 474, 476, 489.
 Profile across the United States, 48.
 " of retaining walls, 407.
 Properties of water, 113.
 " of embankment materials, 342.
 Proportions " " " 349.
 Protection of filter beds, 548, 555.
 " " water supply channels, 431.
 Prony's analysis of experiments, 255.
 Proving press, hydraulic, 477.
 Puddled canal bank, 370.
 Puddle-wall, 351.
 " slope, 352.
 Pump, bucket-plunger, 557, 567.
 " Cornish, 557, 563.
 " piston, 557, 558.
 " plunger, 557, 563.
 " rotary, 558.
 Pumping of water, 557.
 " diagram of, 42.
 " engines, 557, 567, 573, 577.
 " " adaptability of, 584.
 " " cost of supplies, 575, 582.
 " " attendance, 575, 582.
 " " duties, 574, 579, 580, 581, 583.
 " " fuel expenses, 581.
 " " principal divisions, 577.
 " " special trial duties, 580.
 " " values compared, 583.
 " machinery, 591, 592.
 " " duplicate, 590.
 " " for direct pressure, 590,
 591.
 " " Manchester, 585.
 " system, 589, 590.
 " water, cost of, 574, 575.
 Pumps, types of, 557.
 " variable flow through, 559.
 Purity of water, chief requisites for, 144.
 Purity of water, preservation of, 148.
 Purification of water, natural, 134, 157, 158.
- Q.
- Quality of water, sugar test of, 159.
- R.
- Radii, mean of conduits, 441, 442.
 Rainfall, along river courses, 51.
 " diagrams of, 55, 57, 59.
 " gauging, 62.
 " general, 46.
 " in the United States, 53.
 " influences affecting, 60.
 " low cycle, 69, 77, 78.
 " monthly fluctuations in, 56.
 " ratio of floods to, 62.
 " secular fluctuations in, 60.
 " sections of maximum, 47.
 " statistics, review of, 46.
 " volumes of given, 62.
 Rain-gauge, 63.
 Rains, river-basin, 50.
 Rates of fire supplies, 506.
 Ratios of evaporation, 91.
 " monthly consumption, 43.
 " monthly flow in streams, 76.
 " qualification of deduced, 99.
 " rainfall, flow, etc., table, 100, 101.
 " standard gallons, 120.
 " surface to mean velocities in chan-
 nels, 315.
 " variable delivery of water, 564.
 Reaction and gravity, opposition of, 230.
 Reconnoissance for embankment site, 346.
 " of a water-shed, 78.
 Rectangular and trapezoidal walls, moments
 of, 399.
 " weirs, 277.
 Reducer, pipe, 478.
 Relation of supply per capita to total popula-
 tion, 40.
 Relative values of h , h' , and h'' , 253.
 " discharging capacities of pipes, 498,
 500.
 " rates of domestic and fire draughts,
 508.
 Repulsion, molecular, 296.
 Reserve for fire service, 44.
 Reservoir coverings, 556.
 " distributing, 353.
 " embankments, 333.
 " plant growth in, 145.
 " storage, surveys for, 347.
 " strata conditions in, 146.
 " system, 598.
 Reservoirs, subterranean, 105.
 Resistance of the air to a jet, 190.
 " at entrance to a pipe, 226.
 " of masonry revetments, 417.
 " to flow, measure of, 230, 231.
 Resistances to flow within a pipe, 227.
 " " in channels, 300.
 Resultant effect of rain and evaporation, 92.
 Retaining walls, 390.
 " " effect of traffic on, 425.
 " " for earth, table, 420.
 " " front batters, 424.
 " " percolation under, 406.
 " " sections of, 407.
 " " top breadths, 424.
 Revetted conduits, 431.
 Revetments, faced and concrete, 429,
 " final resultants, 418.

- Revetments, resistance of, 417.
 " trapezoidal, table of, 420.
- Riparian rights, 85.
- Rip-rap, slope, 371.
- River waters, 151.
- Rivers and canals, table of flows, 307.
 " basin rains, 50.
 " basins of Maine, 84.
 " courses, rainfall along, 51.
 " pollution committee, 154.
- Roof for filter beds and reservoirs, 548, 555.
- Rotary pump, 558.
- Rubble, grouted, 353.
 " masonry, 252.
 " priming wall, 352.
- S.
- Sand in embankments, 353.
- Sanitary discussions, 152.
 " improvements, 26.
 " office of water, 26.
 " views, precautionary, 154.
- Schussler's process of coating pipes, 489.
- Screens, fish, 365.
- Seasons of floods, 68.
- Sections of maximum rainfall, 47.
- Secular fluctuations in rainfall, 60.
- Sediments, 530, 531.
- Service pipes, frictions in, table, 528.
- Services, high and low, 524.
- Settling basins, 550.
- Sewage impurities, 134.
 " dilution of, 153, 155.
- Shells of conduits, 434.
- Sheet-iron, gauges and weights, 488.
- Sheet-piles, 371.
 " under embankment, 339.
- Short-tubes, 215, 216.
- Showers, source of, 45.
- Sleeves, pipe, 479, 482.
- Slope, earthwork, 344, 345.
 " paving exposed to frost, 355.
 " puddled, 352.
 " embankment, 356.
- Slopes, velocities for given, 258.
- Sluice areas, 360.
- Sluice and pipes, embankment, 355.
 " gate areas, 359.
 " temporary stop-gate, 359.
 " tunneled, embankment, 356, 358.
 " valves, iron, 360.
- Sines of slopes, table, 259.
- Siphon, 182, 184.
- Site for embankment, reconnaissance for, 346.
- Smith's (A. F.) adjustable pipe, 364.
- Soils beneath embankments, 337.
 " evaporation from, 110.
- Solutions, organic, 532.
 " in water, 112.
- Source of showers, 45.
- Springs, mineral, 141.
 " under embankments, 337.
 " and wells, 102.
 " supplying capacity of, 110.
 " waters, 141.
- Stable use of water, 34.
- Statistics, census, 31, 32.
 " rainfall, 46, 52.
- Stability of masonry, 395, 397.
 " pumping machinery, 578.
- Stand pipes, 526, 564.
- Static pressures in pipes, 446.
- Storage, additional required, 98.
 " basins, substratas of, 85.
 " percolation from, 85.
- Storage of water, 84.
 " influence upon a continuous supply, 99.
- Storage of water, effect of evaporation on, 93.
 " required, 95.
- Storage reservoir, 338.
 " embankment, 353.
 " supply to and draught from, table, 96.
- Strata conditions, 146.
- Streams, available annual flow, 94.
 " estimates of flow, 65, 78.
 " flashy and steady, 71.
 " gauging, 296.
 " minimum, mean, and flood flow, 75.
 " ordinary flow of, 80.
 " ratio of monthly flow, 76.
- Strengths of wrought pipe metals, 451, 486, 491.
- Stop-gates in conduits, 436.
- Stop-valve curbs, 515.
 " Ludlow's, 514.
 " Coffin's, 493.
 " Flowers', 493.
 " Eddy's, 511.
 " system, 511.
- Storms, great rain, 61.
- Sub-heads compared, 253.
- Sub-mains, diameters of, 507.
- Subterranean reservoirs, 105.
 " waters, 102.
 " watershed, 109.
 " waters, temperature of, 126.
 " uncertainties of search for, 106.
- Substrata of a storage basin, 85.
- Supply main, diameter of, 506.
 " to, and draught from a reservoir, table, 96, 97.
- Supplying capacity of watersheds, 94.
- Surcharged pressure, earth, 414, 416, 423.
- Surfaces, pressure of water upon, 391, 393.
- Surveys for storage reservoir, 347.
- Sources of water supplies, 587.
- Symbols, definitions of, 235.
 " combined reservoir and direct, 525.
- Systems of water supply, 585, 586.
 " distribution, 493.
 " rainfall, 47, 49, 50.
- T.
- Temperatures, artesian well, 127.
 " of deep sub-surface waters, 126.
 " filter beds, 555.
 " water in pipes, 502.
- Templets, for flange bolt-holes, 460.
- Tenacities of wrought-pipe metals, 451, 486, 491.
- Tests of pipe metals, 472.
- Testing of hydrometers, 325.
- Theory of flow over a weir, 278, 280.
- Thickness of a curved-face wall, 422.
 " dams, table, 387.
 " pipes, formulas, 466.
 " walls for water-pressure, 399.
 " wrought-pipe shells, 447, 486, 488.
- Thompson's molecular estimate, 162.
- Thrusts of a conduit arch, 437.
- Timber weirs, 384.
- Transit, use in gauging, 313, 318, 319.
- Transmission of pressures, 183.
- Traffic, effect upon retaining walls, 425.
- Trapezoidal revetments, table, 420.
- Treacherous strata beneath embankments, 338.
- Trial shafts, at embankment sites, 336.
- Tube gauge, 317.
- Tubes, short, 213.
- Tubercles, in pipes, 247.
- Turbine water-wheels, 559, 579.
- Turned pipe-joints, 458.
- Type curves of rainfall, 55, 57, 59.

U.

- Uniform effect of natural laws, 61.
- Union of high and low services, 524.
- Units of heat utilized, 578.
- Use of water increasing, 39.

V.

- Vacuum ajutage, 214.
 - “ imperfect, short tubes, 215.
 - “ rise of water into, 182.
 - “ tendency to in compound tubes, 221.
 - “ under a weir crest, 292.
- Values of c , 271.
 - “ k and k' , table, 264.
 - “ “ pumping engines compared, 583.
 - “ “ water supplies as an investment, 29.
- Vanne conduit, 438.
- Vapory elements, the, 45.
- Valves, air, 523.
 - “ blow-off, 513.
 - “ Cornish, 569, 570.
 - “ check, 525.
 - “ curbs, 515.
 - “ disk, 571.
 - “ double beat, 569, 570.
 - “ flap, 568.
 - “ iron sluice, 360.
 - “ piston, 569.
 - “ power required to open, 361, 364.
 - “ stop, 493, 511, 513, 514.
 - “ “ indicator, 361.
 - “ “ system, 511.
 - “ “ waste, 513.
- Variable flow through pumps, 559.
- Varnishes for iron, 474, 476, 489.
- Vegetal growth in filter beds, 555.
- Vegetable organic impurities, 128.
- Velocity, conversion into pressure, 227.
 - “ equation, modification of, 270.
 - “ formula for, 249, 250.
- Velocities in canals, 371.
 - “ theoretical table, 190.
 - “ of falling bodies, table, 190.
 - “ for given slopes, table, 259.
 - “ ratios of surface to mean, 315.
 - “ relative, due to different depths in channels, 328.
 - “ of given films, in channels, 311.
 - “ surface in channels, 313.
- Vermin in canal banks, 371.
- Vertical shifting of water, 365.
- Virginia City, wrought-iron pipe, 489.
- Voids of earths and rocks, 103.
- Volume delivered by pipes, table, 495.
 - “ of efflux from an orifice, 194, 209.
 - “ “ formula for, 196.
 - “ flood inversely as the area of the basin, 65.
- Volumes, formulas for flood, 65.
 - “ flood, from watersheds, 381.
 - “ relative, due to different depths in channels, 328.
 - “ of given rainfalls, 62.
 - “ for given depth upon weirs, 290.
 - “ from waste weirs, table, 380.

W.

- Walls, back batters of, 422.
 - “ chamber, 369.
 - “ counterforted, 427.
 - “ curved face, table, 422.
 - “ earth pressure against, 408, 410, 412, 413, 415, 416.
 - “ elements of failure, 427.
 - “ end supports of, 429.
 - “ front batters of, 424.

- Walls, formula of thickness for water pressure, 399.
 - “ foundations of, 395, 406, 407.
 - “ leverage resistance of, 402.
 - “ profiles of, 407.
 - “ retaining, 390.
 - “ to retain water, table, 406.
 - “ to sustain traffic, 425.
 - “ top breadths, 424.
 - “ wharf, 426.
- Waste pipes, embankment, 357.
 - “ sluice, “ 356.
 - “ weir formulas, 379.
 - “ “ volumes, table, 380.
 - “ “ aprons, 383.
 - “ “ ballast, 385.
- weirs, 377.
 - “ discharges over, 378.
 - “ “ forms of, 382.
 - “ “ thickness, table, 387.
- valves, 513.
- Water, analyses of potable, 117.
 - “ characteristics of, 113, 159, 161.
 - “ crystalline forms of, 165.
 - “ choice of, 587.
 - “ clarification of, 530.
 - “ compressibility and elasticity of, 167.
 - “ commercial use of, 34.
 - “ consumption of, 34, 503.
 - “ the composition of, 112.
 - “ domestic use, 34.
 - “ engine, 569.
 - “ evaporation from, 88, 89.
 - “ flow of, 184, 194.
 - “ force of falling, 388.
 - “ hose, use of, 34.
 - “ impregnations, 112, 141.
 - “ impurities, 112, 141.
 - “ molecular actions, 168, 169.
 - “ pressure upon surfaces, 168, 176, 391, 393.
 - “ pressure leverage of, 397.
 - “ physiological office of, 25.
 - “ “ effect of the impurities of, 114.
 - “ pipes, organisms in, 129, 133.
 - “ plant and insect agencies in, 147.
 - “ pumping of, 557.
 - “ rarity of clear, 530.
 - “ ratios of variable flow, 564.
 - “ river, 151.
 - “ sanitary office of, 26.
 - “ storage of, 84.
 - “ spring, 141.
 - “ solvent powers of, 113.
 - “ subterranean, 102.
 - “ sugar test of quality, 159.
 - “ supplies, gathering and delivering, 586.
 - “ “ incidental advantages of, 29.
 - “ “ necessity of, 25.
 - “ supplied, 31, 35, 36, 37, 38, 40.
 - “ supply, permanence of, 585.
 - “ “ systems of, 585, 586.
 - “ volumes and weights, table, 161, 164, 166.
 - “ vertical changes in, 365.
 - “ waste, 34.
 - “ weight of constituents, 164.
 - “ “ pressure and motion of, 161.
 - “ well, 139.
 - “ wheels, 559, 579.
 - “ works, construction of, 333.
- Watersheds, 71, 100.
 - “ supplying capacity of, 94.
- Water-ram in pipes, 449.
- Wave formula, 388.
- Waves, heights of, 388.
- Weir apron, 279.
- Weir benches, 384.
 - “ caps, breadths, 386.

- Weir coefficients, 288, 289, 291.
 " crests, 278, 292, 293.
 " gauging, 77.
 " overfalls, 377.
- Weirs, crest contractions, 280.
 " dimensions of, 278, 279.
 " discharges over, table, 289, 290.
 " experiments with large, 284.
 " forms of, 277.
 " formula for wide-crested, 293.
 " " " depth upon, 286, 287.
 " formulas, 282, 283, 284, 286.
 " gratings in front of, 292.
 " hook-gauge for, 297.
 " initial velocity of approach to, 285, 292.
 " measuring, 277, 295.
 " rule gauge for, 298.
 " stability of, 279.
 " tail-water of, 292.
 " triangular notch, 294, 295.
 " tube and scale-gauge for, 298.
 " timber, 384.
 " varying lengths, 279.
 " volumes, formulas for, 282, 283, 284,
 " 286, 287, 293.
 " waste, 337, 383.
 " wide-crested, 293.
- Weight, a line a measure of, 173.
- Weight, a measure of pressure, 173.
 " and volume of water, table, 166.
 " leverage of masonry, 398.
 " of pond water, 167.
- Weights of cast pipes, 465, 468, 469.
 " " embankment materials, 341.
 " " molecules, 168.
- Well, intercepting, 546.
 " water, 139.
 " waters, analyses of, 121.
- Wells and springs, 102, 110.
 " condition of overflowing, 107.
 " fouling of old, 140.
 " influence upon each other, 107.
 " impurities of deep, 125.
 " locations for, 139.
 " watersheds of, 108.
- Western rain system, 47.
- Wharf cap-log, 426.
 " fender and belay piles, 427.
 " walls, 426.
- Wood pipes, 491.
- Woltmann's tachometer, 322.
- Wrought-iron pipes, 479.
 " " pipe-joint, cast, 483.
 " " plates, gauges, and weights, 488.
- Wyckoff's wood-pipe, 491.



SCIENTIFIC BOOKS

PUBLISHED BY

D. VAN NOSTRAND,

23 Murray Street and 27 Warren Street,

NEW YORK.

Any Book in this Catalogue, sent free by mail on receipt of price.

Weisbach's Mechanics.

Fourth Edition, Revised. 8vo. Cloth. \$10.00.

A MANUAL OF THEORETICAL MECHANICS. By Julius Weisbach, Ph. D. Translated from the fourth augmented and improved German edition, with an introduction to the Calculus, by Eckley B. Coxe, A. M., Mining Engineer. 1100 pages and 902 wood-cut illustrations.

Francis' Lowell Hydraulics.

Third Edition. 4to. Cloth. \$15.00.

LOWELL HYDRAULIC EXPERIMENTS—being a Selection from Experiments on Hydraulic Motors, on the Flow of Water over Weirs, and in open Canals of Uniform Rectangular Section, made at Lowell, Mass. By J. B. Francis, Civil Engineer. Third edition, revised and enlarged, including many New Experiments on Gauging Water in Open Canals, and on the Flow through Submerged Orifices and Diverging Tubes. With 23 copperplates, beautifully engraved, and about 100 new pages of text.

Kirkwood on Filtration.

4to. Cloth. \$15.00.

REPORT ON THE FILTRATION OF RIVER WATERS, for the Supply of Cities, as practised in Europe, made to the Board of Water Commissioners of the City of St. Louis. By JAMES P. KIRKWOOD. Illustrated by 30 double-plate engravings.

Rogers' Geology of Pennsylvania.

3 Vols. 4to, with Portfolio of Maps. Cloth. \$30.00.

THE GEOLOGY OF PENNSYLVANIA. A Government Survey. With a general view of the Geology of the United States, Essays on the Coal Formation and its Fossils, and a description of the Coal Fields of North America and Great Britain. By HENRY DARWIN ROGERS, Late State Geologist of Pennsylvania. Splendidly illustrated with Plates and Engravings in the Text

Merrill's Iron Truss Bridges.

Third Edition. 4to. Cloth. \$5.00.

IRON TRUSS BRIDGES FOR RAILROADS. The Method of Calculating Strains in Trusses, with a careful comparison of the most prominent Trusses, in reference to economy in combination, etc., etc. By Bvt. Col. WILLIAM E. MERRILL, U.S.A., Corps of Engineers. Nine lithographed plates of illustrations.

Shreve on Bridges and Roofs.

8vo, 87 wood-cut illustrations. Cloth. \$5.00.

A TREATISE ON THE STRENGTH OF BRIDGES AND ROOFS—comprising the determination of Algebraic formulas for Strains in Horizontal, Inclined or Rafter, Triangular, Bowstring, Lenticular and other Trusses, from fixed and moving loads, with practical applications and examples, for the use of Students and Engineers. By Samuel H. Shreve, A. M., Civil Engineer.

The Kansas City Bridge.

4to. Cloth. \$6.00

WITH AN ACCOUNT OF THE REGIMEN OF THE MISSOURI RIVER,—and a description of the Methods used for Founding in that River. By O. Chanute, Chief Engineer, and George Morison, Assistant Engineer. Illustrated with five lithographic views and twelve plates of plans.

Clarke's Quincy Bridge.

4to. Cloth. \$7.50.

DESCRIPTION OF THE IRON RAILWAY. Bridge across the Mississippi River at Quincy, Illinois. By Thomas Curtis Clarke, Chief Engineer. With twenty-one lithographed plans.

Whipple on Bridge Building.

New edition. 8vo. Illustrated. Cloth. \$4.

AN ELEMENTARY AND PRACTICAL TREATISE ON BRIDGE BUILDING.
By S. Whipple, C. E.

Roebing's Bridges.

Imperial folio. Cloth. \$25.00.

LONG AND SHORT SPAN RAILWAY BRIDGES. By John A. Roebing,
C. E. With large copperplate engravings of plans and views.

Dubois' Graphical Statics.

8vo. 60 Illustrations. Cloth. \$2.00.

THE NEW METHOD OF GRAPHICAL STATICS. By A. J. Dubois, C. E.,
Ph. D.

Stahl's Telodynamics.

18mo. Boards. 50 cents.

ON TRANSMISSION OF POWER BY WIRE ROPE. By Albert W. Stahl.
Being No. 28 of Van Nostrand's Science Series.

Bow on Bracing.

156 Illustrations on Stone. 8vo. Cloth. \$1.50.

A TREATISE ON BRACING,—with its application to Bridges and other
Structures of Wood or Iron. By Robert Henry Bow, C. E.

Stoney on Strains.

New and Revised Edition, with numerous illustrations. Royal 8vo, 664 pp.
Cloth. \$12.50.

THE THEORY OF STRAINS IN GIRDERS—and Similar Structures, with
Observations on the Application of Theory to Practice, and Tables of
Strength and other Properties of Materials. By Bindon B. Stoney,
B. A.

Henrici's Skeleton Structures.

8vo. Cloth. \$1.50.

SKELETON STRUCTURES, especially in their Application to the building
of Steel and Iron Bridges. By OLAUS HENRICI.

Burgh's Modern Marine Engineering.

One thick 4to vol. Cloth. \$25.00. Half morocco. \$30.00.

MODERN MARINE ENGINEERING, applied to Paddle and Screw Propulsion. Consisting of 36 Colored Plates, 259 Practical Wood-cut Illustrations, and 403 pages of Descriptive Matter, the whole being an exposition of the present practice of the following firms: Messrs. J. Penn & Sons; Messrs. Maudslay, Sons & Field; Messrs. James Watt & Co.; Messrs. J. & G. Rennie; Messrs. R. Napier & Sons; Messrs. J. & W. Dudgeon; Messrs. Ravenhill & Hodgson; Messrs. Humphreys & Tenant; Mr. J. T. Spencer, and Messrs. Forrester & Co. By N. P. BURGH, Engineer.

King's Notes on Steam.

Nineteenth Edition. 8vo. \$2.00.

LESSONS AND PRACTICAL NOTES ON STEAM,—the Steam Engine, Propellers, &c., &c., for Young Engineers. By the late W. R. KING, U. S. N. Revised by Chief-Engineer J. W. KING, U. S. Navy.

Link and Valve Motions, by W. S. Auchincloss.

Sixth Edition. 8vo. Cloth. \$3.00.

APPLICATION OF THE SLIDE VALVE and Link Motion to Stationary, Portable, Locomotive and Marine Engines. By WILLIAM S. AUCHINCLOSS. Designed as a hand-book for Mechanical Engineers. Dimensions of the valve are found by means of a Printed Scale, and proportions of the link determined *without* the assistance of a model. With 37 wood-cuts and 21 lithographic plates, with copperplate engraving of the Travel Scale.

Bacon's Steam-Engine Indicator.

12mo. Cloth. \$1.00 Mor. \$1.50.

A TREATISE ON THE RICHARDS STEAM-ENGINE INDICATOR,—with directions for its use. By CHARLES T. PORTER. Revised, with notes and large additions as developed by American Practice, with an Appendix containing useful formulæ and rules for Engineers. By F. W. BACON, M. E., Illustrated. Second Edition.

Isherwood's Engineering Precedents.

Two Vols. in One. 8vo. Cloth. \$2.50.

ENGINEERING PRECEDENTS FOR STEAM MACHINERY.—By B. F. ISHERWOOD, Chief Engineer, U. S. Navy. With illustrations.

Slide Valve by Eccentrics, by Prof. C. W. MacCord.

4to. Illustrated. Cloth, \$3.00

A PRACTICAL TREATISE ON THE SLIDE VALVE BY ECCENTRICS,—examining by methods the action of the Eccentric upon the Slide Valve, and explaining the practical processes of laying out the movements, adapting the valve for its various duties in the steam-engine. For the use of Engineers, Draughtsmen, Machinists, and Students of valve motions in general. By C. W. MACCORD, A. M., Professor of Mechanical Drawing, Stevens' Institute of Technology, Hoboken, N. J.

Stillman's Steam-Engine Indicator.

12mo. Cloth. \$1.00

THE STEAM-ENGINE INDICATOR,—and the Improved Manometer Steam and Vacuum Gauges ; their utility and application. By PAUL STILLMAN. New edition.

Porter's Steam-Engine Indicator.

Third Edition. Revised and Enlarged. 8vo. Illustrated. Cloth. \$3.50.

A TREATISE ON THE RICHARDS STEAM-ENGINE INDICATOR,—and the Development and Application of Force in the Steam-Engine. By CHARLES T. PORTER.

McCulloch's Theory of Heat.

8vo. Cloth. 3.50.

A TREATISE ON THE MECHANICAL THEORY OF HEAT, AND ITS APPLICATIONS TO THE STEAM-ENGINE. By Prof. R. S. McCULLOCH, of the Washington and Lee University, Lexington, Va.

Van Buren's Formulas.

8vo. Cloth. \$2.00.

INVESTIGATIONS OF FORMULAS,—for the Strength of the Iron parts of Steam Machinery. By J. D. VAN BUREN, Jr., C. E. Illustrated.

Stuart's Successful Engineer.

18mo. Boards. 50 cents.

HOW TO BECOME A SUCCESSFUL ENGINEER. Being Hints to Youths intending to adopt the Profession. By BERNARD STUART, Engineer. Sixth Edition.

Stuart's Naval Dry Docks.

Twenty-four engravings on steel. Fourth edition. 4to. Cloth. \$6.00.

THE NAVAL DRY DOCKS OF THE UNITED STATES By CHARLES B. STUART, Engineer in Chief U. S. Navy.

Ward's Steam for the Million.

8vo. Cloth. \$1.00.

STEAM FOR THE MILLION. A Popular Treatise on Steam and its Application to the Useful Arts, especially to Navigation. By J. H. WARD, Commander U. S. Navy.

Tunner on Roll-Turning.

1 vol. 8vo. and 1 vol. folio plates. \$10.00.

A TREATISE ON ROLL-TURNING FOR THE MANUFACTURE OF IRON, by PETER TUNNER. Translated by JOHN B. PEARSE, of the Pennsylvania Steel Works. With numerous wood-cuts, 8vo., together with a folio atlas of 10 lithographed plates of Rolls, Measurements, &c.

Grüner on Steel.

8vo. Cloth. \$3.50.

THE MANUFACTURE OF STEEL. By M. L. GRÜNER; translated from the French. By LENOX SMITH, A.M., E.M.; with an Appendix on the Bessemer Process in the United States, by the translator. Illustrated by lithographed drawings and wood-cuts.

Barba on the Use of Steel.

12mo. Illustrated. Cloth. \$1.50.

THE USE OF STEEL IN CONSTRUCTION. Methods of Working, Applying, and Testing Plates and Bars. By J. BARBA, Chief Naval Constructor. Translated from the French, with a Preface, by A. L. HOLLEY, P.B.

Bell on Iron Smelting.

8vo. Cloth. \$6.00.

CHEMICAL PHENOMENA OF IRON SMELTING. An experimental and practical examination of the circumstances which determine the capacity of the Blast Furnace, the Temperature of the Air, and the Proper Condition of the Materials to be operated upon. By I. LOWTHIAN BELL.

The Useful Metals and their Alloys; Scoffren, Truran, and others.

Fifth Edition. 8vo. Half calf. \$3.75

THE USEFUL METALS AND THEIR ALLOYS, employed in the conversion of IRON, COPPER, TIN, ZINC, ANTIMONY, AND LEAD ORES, with their applications to the INDUSTRIAL ARTS. By JOHN SCOFFREN, WILLIAM TRURAN, WILLIAM CLAY, ROBERT OXLAND, WILLIAM FAIRBAIRN, W. C. AITKIN, and WILLIAM VOSE PICKETT.

Collins' Useful Alloys.

18mo. Flexible. 50 cents.

THE PRIVATE BOOK OF USEFUL ALLOYS and Memoranda for Goldsmiths, Jewellers, etc. By JAMES E. COLLINS.

Joynson's Metal Used in Construction.

12mo. Cloth. 75 cents.

THE METALS USED IN CONSTRUCTION: Iron, Steel, Bessemer Metal, etc., etc. By FRANCIS H. JOYNSON. Illustrated.

Dodd's Dictionary of Manufactures, etc.

12mo. Cloth. \$1.50.

DICTIONARY OF MANUFACTURES, MINING, MACHINERY, AND THE INDUSTRIAL ARTS. By GEORGE DODD.

Von Cotta's Ore Deposits.

8vo. Cloth. \$4.00.

TREATISE ON ORE DEPOSITS. By BERNHARD VON COTTA, Professor of Geology in the Royal School of Mines, Freiburg, Saxony. Translated from the second German edition, by FREDERICK PRIME, Jr., Mining Engineer, and revised by the author; with numerous illustrations.

Plattner's Blow-Pipe Analysis.

Third Edition. Revised. 568 pages. 8vo. Cloth. \$5.00.

PLATTNER'S MANUAL OF QUALITATIVE AND QUANTITATIVE ANALYSIS WITH THE BLOW-PIPE. From the last German edition, Revised and enlarged. By Prof. TH. RICHTER, of the Royal Saxon Mining Academy. Translated by Professor H. B. CORNWALL; assisted by JOHN H. CASWELL. With eighty-seven wood-cuts and Lithographic Plate.

Plympton's Blow-Pipe Analysis.

12mo. Cloth. \$1.50.

THE BLOW-PIPE: A Guide to its Use in the Determination of Salts and Minerals. Compiled from various sources, by GEORGE W. PLYMPTON, C.E., A.M., Professor of Physical Science in the Polytechnic Institute, Brooklyn, N.Y.

Pynchon's Chemical Physics.

New Edition. Revised and enlarged. Crown 8vo. Cloth. \$3.00.

INTRODUCTION TO CHEMICAL PHYSICS; Designed for the Use of Academies, Colleges, and High Schools. Illustrated with numerous engravings, and containing copious experiments, with directions for preparing them. By THOMAS RUGGLES PYNCHON, M.A., President of Trinity College, Hartford.

Eliot and Storer's Qualitative Chemical Analysis.

New Edition. Revised. 12mo. Illustrated. Cloth. \$1.50.

A COMPENDIOUS MANUAL OF QUALITATIVE CHEMICAL ANALYSIS. By CHARLES W. ELIOT and FRANK H. STORER. Revised, with the coöperation of the Authors, by WILLIAM RIPLEY NICHOLS, Professor of Chemistry in the Massachusetts Institute of Technology.

Rammelsberg's Chemical Analysis.

8vo. Cloth. \$2.25.

GUIDE TO A COURSE OF QUANTITATIVE CHEMICAL ANALYSIS, ESPECIALLY OF MINERALS AND FURNACE PRODUCTS. Illustrated by Examples. By C. F. RAMMELSBERG. Translated by J. TOWLER, M.D.

Naquet's Legal Chemistry.

Illustrated. 12mo. Cloth. \$2.00.

LEGAL CHEMISTRY. A Guide to the Detection of Poisons, Falsification of Writings, Adulteration of Alimentary and Pharmaceutical Substances; Analysis of Ashes, and Examination of Hair, Coins, Fire-arms, and Stains, as Applied to Chemical Jurisprudence. For the Use of Chemists, Physicians, Lawyers, Pharmacists, and Experts. Translated, with additions, including a List of Books and Memoirs on Toxicology, etc., from the French of A. NAQUET. By J. P. BATTERSHALL, Ph. D., with a Preface by C. F. CHANDLER, Ph. D., M.D., LL.D.

Prescott's Proximate Organic Analysis.

12mo. Cloth. \$1.75.

OUTLINES OF PROXIMATE ORGANIC ANALYSIS, for the Identification, Separation, and Quantitative Determination of the more commonly occurring Organic Compounds. By ALBERT B. PRESCOTT, Professor of Organic and Applied Chemistry in the University of Michigan.

Prescott's Alcoholic Liquors.

12mo. Cloth. \$1.50.

CHEMICAL EXAMINATION OF ALCOHOLIC LIQUORS.—A Manual of the Constituents of the Distilled Spirits and Fermented Liquors of Commerce, and their Qualitative and Quantitative Determinations. By ALBERT B. PRESCOTT, Professor of Organic and Applied Chemistry in the University of Michigan.

Prescott and Douglas's Qualitative Chemical Analysis.

Second Edition. Revised. 8vo. Cloth. \$3.50.

A Guide in the Practical Study of Chemistry and in the Work of Analysis.

Pope's Modern Practice of the Electric Telegraph.

Ninth Edition. 8vo. Cloth. \$2.00.

A Hand-book for Electricians and Operators. By FRANK L. POPE. Ninth edition. Revised and enlarged, and fully illustrated.

Sabine's History of the Telegraph.

Second Edition. 12mo. Cloth. \$1.25.

HISTORY AND PROGRESS OF THE ELECTRIC TELEGRAPH, with Descriptions of some of the Apparatus. By ROBERT SABINE, C.E.

Haskins' Galvanometer.

Pocket form. Illustrated. Morocco tucks. \$2.00.

THE GALVANOMETER, AND ITS USES;—A Manual for Electricians and Students. By C. H. HASKINS.

Larrabee's Secret Letter and Telegraph

18mo. Cloth. \$1.00.

CIPHER AND SECRET LETTER AND TELEGRAPHIC CODE, with Hogg's Improvements. By C. S. LARRABEE.

Gillmore's Limes and Cements.

Fifth Edition. Revised and Enlarged. 8vo. Cloth. \$4.00.

PRACTICAL TREATISE ON LIMES, HYDRAULIC CEMENTS, AND MORTARS. By Q. A. GILLMORE, Lt.-Col. U. S. Corps of Engineers. Brevet Major-General U. S. Army.

Gillmore's Coignet Beton.

Nine Plates, Views, etc. 8vo. Cloth. \$2.50.

COIGNET BETON AND OTHER ARTIFICIAL STONE.—By Q. A. GILLMORE, Lt.-Col. U. S. Corps of Engineers, Brevet Major-General U.S. Army.

Gillmore on Roads.

Seventy Illustrations. 12mo. Cloth. \$2.00.

A PRACTICAL TREATISE ON THE CONSTRUCTION OF ROADS, STREETS, AND PAVEMENTS. By Q. A. GILLMORE, Lt.-Col. U. S. Corps of Engineers, Brevet Major-General U. S. Army.

Gillmore's Building Stones.

8vo. Cloth. \$1.00.

REPORT ON STRENGTH OF THE BUILDING STONES IN THE UNITED STATES, etc.

Holley's Railway Practice.

1 vol. folio. Cloth. \$12.00.

AMERICAN AND EUROPEAN RAILWAY PRACTICE, in the Economical Generation of Steam, including the materials and construction of Coal-burning Boilers, Combustion, the Variable Blast, Vaporization, Circulation, Super-heating, Supplying and Heating Feed-water, &c., and the adaptation of Wood and Coke-burning Engines to Coal-burning; and in Permanent Way, including Road-bed, Sleepers, Rails, Joint Fastenings, Street Railways, etc., etc. By ALEXANDER L. HOLLEY, B.P. With 77 lithographed plates.

Useful Information for Railway Men.

Pocket form. Morocco, gilt. \$2.00.

Compiled by W. G. HAMILTON, Engineer. New Edition, Revised and Enlarged. 577 pages.

Stuart's Civil and Military Engineers of
America.

8vo. illustrated. Cloth. \$5.00.

THE CIVIL AND MILITARY ENGINEERS OF AMERICA. By General CHARLES B. STUART, Author of "Naval Dry Docks of the United States," etc., etc. Embellished with nine finely-executed Portraits on steel of eminent Engineers, and illustrated by Engravings of some of the most important and original works constructed in America.

Ernst's Manual of Military Engineering.

193 Wood-cuts and 3 Lithographed Plates. 12mo. Cloth. \$5.00.

A MANUAL OF PRACTICAL MILITARY ENGINEERING. Prepared for the use of the Cadets of the U. S. Military Academy, and for Engineer Troops. By Capt. O. H. ERNST, Corps of Engineers, Instructor in Practical Military Engineering, U. S. Military Academy.

Simms' Levelling.

12mo. Cloth. \$2.50.

A TREATISE ON THE PRINCIPLES AND PRACTICE OF LEVELLING, showing its application to purposes of Railway Engineering and the Construction of Roads, etc. By FREDERICK W. SIMMS, C.E. From the fifth London edition, Revised and Corrected, with the addition of Mr. Law's Practical Examples for Setting-out Railway Curves. Illustrated with three lithographic plates and numerous wood-cuts.

Jeffers' Nautical Surveying.

Illustrated with 9 Copperplates and 31 Wood-cut Illustrations. 8vo. Cloth. \$5.00.

NAUTICAL SURVEYING. By WILLIAM N. JEFFERS, Captain U. S. Navy.

Text-book of Surveying.

8vo. 9 Lithograph Plates and several Wood-cuts. Cloth. \$2.00.

A TEXT-BOOK ON SURVEYING, PROJECTIONS, AND PORTABLE INSTRUMENTS, for the use of the Cadet Midshipmen, at the U. S. Naval Academy.

The Plane Table.

8vo. Cloth. \$2.00.

ITS USES IN TOPOGRAPHICAL SURVEYING. From the papers of the U. S. Coast Survey.

Chauvenet's Lunar Distances.

8vo. Cloth. \$2.00.

NEW METHOD OF CORRECTING LUNAR DISTANCES, and Improved Method of Finding the Error and Rate of a Chronometer, by equal altitudes. By WM. CHAUVENET, LL.D., Chancellor of Washington University of St. Louis.

Burt's Key to Solar Compass.

Second Edition. Pocket-book form. Tuck. \$2.50.

KEY TO THE SOLAR COMPASS, and Surveyor's Companion; comprising all the Rules necessary for use in the Field; also Description of the Linear Surveys and Public Land System of the United States, Notes on the Barometer, Suggestions for an Outfit for a Survey of Four Months, etc. By W. A. BURT, U. S. Deputy Surveyor.

Howard's Earthwork Mensuration.

8vo. Illustrated. Cloth. \$1.50.

EARTHWORK MENSURATION ON THE BASIS OF THE PRISMOIDAL FORMULÆ. Containing simple and labor-saving method of obtaining Prismoidal Contents directly from End Areas. Illustrated by Examples, and accompanied by Plain Rules for practical uses. By CONWAY R. HOWARD, Civil Engineer, Richmond, Va.

Morris' Easy Rules.

78 Illustrations. 8vo. Cloth. \$1.50.

EASY RULES FOR THE MEASUREMENT OF EARTHWORKS, by means of the Prismoidal Formula. By ELWOOD MORRIS, Civil Engineer.

Clevenger's Surveying.

Illustrated Pocket Form. Morocco, gilt. \$2.50.

A TREATISE ON THE METHOD OF GOVERNMENT SURVEYING, as prescribed by the U. S. Congress and Commissioner of the General Land Office. With complete Mathematical, Astronomical, and Practical Instructions for the use of the U. S. Surveyors in the Field, and Students who contemplate engaging in the business of Public Land Surveying. By S. V. CLEVINGER, U. S. Deputy Surveyor.

Hewson on Embankments.

8vo. Cloth. \$2.00.

PRINCIPLES AND PRACTICE OF EMBANKING LANDS from River Floods, as applied to the Levees of the Mississippi. By WILLIAM HEWSON, Civil Engineer.

Minifie's Mechanical Drawing.

Ninth Edition. Royal 8vo. Cloth. \$4.00.

A TEXT-BOOK OF GEOMETRICAL DRAWING, for the use of Mechanics and Schools. With illustrations for Drawing Plans, Sections, and Elevations of Buildings and Machinery; an Introduction to Isometrical Drawing, and an Essay on Linear Perspective and Shadows. With over 200 diagrams on steel. By WILLIAM MINIFIE, Architect. With an Appendix on the Theory and Application of Colors.

Minifie's Geometrical Drawing.

New Edition. Enlarged. 12mo. Cloth. \$2.00.

GEOMETRICAL DRAWING. Abridged from the octavo edition, for the use of Schools. Illustrated with 48 steel plates.

Free Hand Drawing.

Profusely Illustrated. 18mo. Boards. 50 cents.

A GUIDE TO ORNAMENTAL, Figure, and Landscape Drawing. By an Art Student.

The Mechanic's Friend.

12mo. Cloth. 300 Illustrations. \$1.50.

THE MECHANIC'S FRIEND. A Collection of Receipts and Practical Suggestions, relating to Aquaria—Bronzing—Cements—Drawing—Dyes—Electricity—Gilding—Glass-working—Glues—Horology—Lacquers—Locomotives—Magnetism—Metal-working—Modelling—Photography—Pyrotechny—Railways—Solders—Steam-Engine—Telegraphy—Taxidermy—Varnishes—Waterproofing—and Miscellaneous Tools, Instruments, Machines, and Processes connected with the Chemical and Mechanical Arts. By WILLIAM E. AXON, M.R.S.L.

Harrison's Mechanic's Tool-Book.

44 Illustrations. 12mo. Cloth. \$1.50.

MECHANICS' TOOL BOOK, with Practical Rules and Suggestions, for the use of Machinists, Iron Workers, and others. By W. B. HARRISON.

Randall's Quartz Operator's Hand-Book.

12mo. Cloth. \$2 00.

QUARTZ OPERATOR'S HAND-BOOK. By P. M. RANDALL. New edition, Revised and Enlarged. Fully illustrated.

Joynson on Machine Gearing.

8vo. Cloth. \$2.00.

THE MECHANIC'S AND STUDENT'S GUIDE in the designing and Construction of General Machine Gearing, as Eccentrics, Screws, Toothed Wheels, etc., and the Drawing of Rectilineal and Curved Surfaces. Edited by FRANCIS H. JOYNSON. With 18 folded plates.

Silversmith's Hand-Book.

Fourth Edition. Illustrated. 12mo. Cloth. \$3.00.

A PRACTICAL HAND-BOOK FOR MINERS, Metallurgists, and Assayers. By JULIUS SILVERSMITH. Illustrated.

Barnes' Submarine Warfare.

8vo. Cloth. \$5.00.

SUBMARINE WARFARE, DEFENSIVE AND OFFENSIVE. Descriptions of the various forms of Torpedoes, Submarine Batteries and Torpedo Boats actually used in War. Methods of Ignition by Machinery, Contact Fuzes, and Electricity, and a full account of experiments made to determine the Explosive Force of Gunpowder under Water. Also a discussion of the Offensive Torpedo system, its effect upon Iron-clad Ship systems, and influence upon future Naval Wars. By Lieut.-Com. JOHN S. BARNES, U.S.N. With twenty lithographic plates and many wood-cuts.

Foster's Submarine Blasting.

4to. Cloth. \$3.50.

SUBMARINE BLASTING, in Boston Harbor, Massachusetts—Removal of Tower and Corwin Rocks. By JOHN G. FOSTER, U. S. Eng. and Bvt. Major-General U. S. Army. With seven plates.

Mowbray's Tri-Nitro-Glycerine.

8vo. Cloth. Illustrated. \$3.00.

TRI-NITRO-GLYCERINE, as applied in the Hoosac Tunnel, and to Submarine Blasting, Torpedoes, Quarrying, etc.

Williamson on the Barometer.

4to. Cloth. \$15.00.

ON THE USE OF THE BAROMETER ON SURVEYS AND RECONNAISSANCES. Part I.—Meteorology in its Connection with Hypsometry. Part II.—Barometric Hypsometry. By R. S. WILLIAMSON, Bvt. Lt.-Col. U. S. A., Major Corps of Engineers. With illustrative tables and engravings.

Williamson's Meteorological Tables.

4to. Flexible Cloth. \$2.50.

PRACTICAL TABLES IN METEOROLOGY AND HYPOMETRY, in connection with the use of the Barometer. By Col. R. S. WILLIAMSON, U.S.A.

Butler's Projectiles and Rifled Cannon.

4to. 36 Plates. Cloth. \$7.50.

PROJECTILES AND RIFLED CANNON. A Critical Discussion of the Principal Systems of Rifling and Projectiles, with Practical Suggestions for their Improvement. By Capt. JOHN S. BUTLER, Ordnance Corps, U. S. A.

Benét's Chronoscope.

Second Edition. Illustrated. 4to. Cloth. \$3.00.

ELECTRO-BALLISTIC MACHINES, and the Schultz Chronoscope. By Lt.-Col. S. V. BENÉT, Chief of Ordnance U. S. A.

Michaelis' Chronograph

4to. Illustrated. Cloth. \$3.00.

THE LE BOULENGÉ CHRONOGRAPH. With three lithographed folding plates of illustrations. By Bvt. Captain O. E. MICHAELIS, Ordnance Corps, U. S. A.

Nugent on Optics.

12mo. Cloth. \$1.50.

TREATISE ON OPTICS; or, Light and Sight, theoretically and practically treated; with the application to Fine Art and Industrial Pursuits. By E. NUGENT. With 103 illustrations.

Peirce's Analytic Mechanics.

4to. Cloth. \$10.00.

SYSTEM OF ANALYTIC MECHANICS. By BENJAMIN PEIRCE, Professor of Astronomy and Mathematics in Harvard University.

Craig's Decimal System.

Square 32mo. Limp. 50c.

WEIGHTS AND MEASURES. An Account of the Decimal System, with Tables of Conversion for Commercial and Scientific Uses. By B. F. CRAIG, M.D.

Alexander's Dictionary of Weights and Measures.

New Edition. 8vo. Cloth. \$3.50.

UNIVERSAL DICTIONARY OF WEIGHTS AND MEASURES, Ancient and Modern, reduced to the standards of the United States of America. By J. H. ALEXANDER.

Elliot's European Light-Houses.

51 Engravings and 21 Wood-cuts. 8vo. Cloth. \$5.00.

EUROPEAN LIGHT-HOUSE SYSTEMS. Being a Report of a Tour of Inspection made in 1873. By Major GEORGE H. ELLIOT, U. S. Engineers.

Sweet's Report on Coal.

With Maps. 8vo. Cloth. \$3.00.

SPECIAL REPORT ON COAL. By S. H. SWEET.

Colburn's Gas Works of London.

12mo. Boards. 60 cents.

GAS WORKS OF LONDON. By ZERAH COLBURN.

Walker's Screw Propulsion.

8vo. Cloth. 75 cents.

NOTES ON SCREW PROPULSION, its Rise and History. By Capt. W. H. WALKER, U. S. Navy.

Pook on Shipbuilding.

8vo. Cloth. Illustrated. \$5.00.

METHOD OF PREPARING THE LINES AND DRAUGHTING VESSELS PROPELLED BY SAIL OR STEAM, including a Chapter on Laying-off on the Mould-loft Floor. By SAMUEL M. POOK, Naval Constructor.

Saeltzer's Acoustics.

12mo. Cloth. \$2.00.

TREATISE ON ACOUSTICS in connection with Ventilation. By ALEXANDER SAELTZER.

Eassie on Wood and its Uses.

250 Illustrations. 8vo. Cloth. \$1.50.

A HAND-BOOK FOR THE USE OF CONTRACTORS, Builders, Architects, Engineers, Timber Merchants, etc., with information for drawing up Designs and Estimates.

Wanklyn's Milk Analysis.

12mo. Cloth. \$1.00.

MILK ANALYSIS. A Practical Treatise on the Examination of Milk, and its Derivatives, Cream, Butter, and Cheese. By J. ALFRED WANKLYN, M.R.C.S.

Rice & Johnson's Differential Functions.

Paper, 12mo. 50 cents.

ON A NEW METHOD OF OBTAINING THE DIFFERENTIALS OF FUNCTIONS, with especial reference to the Newtonian Conception of Rates or Velocities. By J. MINOT RICE, Prof. of Mathematics, U. S. Navy, and W. WOOLSEY JOHNSON, Prof. of Mathematics, St. John's College, Annapolis.

Coffin's Navigation.

Fifth Edition. 12mo. Cloth. \$3.50.

NAVIGATION AND NAUTICAL ASTRONOMY. Prepared for the use of the U. S. Naval Academy. By J. H. C. COFFIN, Professor of Astronomy, Navigation and Surveying; with 52 wood-cut illustrations.

Clark's Theoretical Navigation,

8vo. Cloth. \$3.00.

THEORETICAL NAVIGATION AND NAUTICAL ASTRONOMY. By LEWIS CLARK, Lieut.-Commander, U. S. Navy. Illustrated with 41 wood-cuts, including the Vernier.

Toner's Dictionary of Elevations.

8vo. Paper, \$3.00 Cloth, \$3.75.

DICTIONARY OF ELEVATIONS AND CLIMATIC REGISTER OF THE UNITED STATES. Containing, in addition to Elevations, the Latitude, Mean Annual Temperature, and the total Annual Rain Fall of many Localities; with a brief introduction on the Orographic and Physical Peculiarities of North America. By J. M. TONER, M.D.

VAN NOSTRAND'S SCIENCE SERIES.

It is the intention of the Publisher of this Series to issue them at intervals of about a month. They will be put up in a uniform, neat, and attractive form, 18mo, fancy boards. The subjects will be of an eminently scientific character, and embrace as wide a range of topics as possible, all of the highest character.

Price, 50 Cents Each.

- I. CHIMNEYS FOR FURNACES, FIRE-PLACES, AND STEAM BOILERS. By R. ARMSTRONG, C.E.
- II. STEAM BOILER EXPLOSIONS. By ZERAH COLBURN.
- III. PRACTICAL DESIGNING OF RETAINING WALLS. By ARTHUR JACOB, A.B. With Illustrations.
- IV. PROPORTIONS OF PINS USED IN BRIDGES. By CHARLES E. BENDER, C.E. With Illustrations.
- V. VENTILATION OF BUILDINGS. By W. F. BUTLER. With Illustrations.
- VI. ON THE DESIGNING AND CONSTRUCTION OF STORAGE RESERVOIRS. By ARTHUR JACOB. With Illustrations.
- VII. SURCHARGED AND DIFFERENT FORMS OF RETAINING WALLS. By JAMES S. TATE, C.E.
- VIII. A TREATISE ON THE COMPOUND ENGINE. By JOHN TURNBULL. With Illustrations.
- IX. FUEL. By C. WILLIAM SIEMENS, to which is appended the value of ARTIFICIAL FUELS AS COMPARED WITH COAL. By JOHN WORM-ALD, C.E.
- X. COMPOUND ENGINES. Translated from the French of A. MALLET. Illustrated.
- XI. THEORY OF ARCHES. By Prof. W. ALLAN, of the Washington and Lee College. Illustrated.
- XII. A PRACTICAL THEORY OF VOUSOIR ARCHES. By WILLIAM CAIN, C.E. Illustrated.

-
- XIII. A PRACTICAL TREATISE ON THE GASES MET WITH IN COAL MINES. By the late J. J. ATKINSON, Government Inspector of Mines for the County of Durham, England.
- XIV. FRICTION OF AIR IN MINES. By J. J. ATKINSON, author of "A Practical Treatise on the Gases met with in Coal Mines."
- XV. SKEW ARCHES. By Prof. E. W. HYDE, C.E. Illustrated with numerous engravings and three folded plates.
- XVI. A GRAPHIC METHOD FOR SOLVING CERTAIN ALGEBRAIC EQUATIONS. By Prof. GEORGE L. VOSE. With Illustrations.
- XVII. WATER AND WATER SUPPLY. By Prof. W. H. CORFIELD, M.A., of the University College, London.
- XVIII. SEWERAGE AND SEWAGE UTILIZATION. By Prof. W. H. CORFIELD, M.A., of the University College, London.
- XIX. STRENGTH OF BEAMS UNDER TRANSVERSE LOADS. By Prof. W. ALLAN, author of "Theory of Arches." With Illustrations
- XX. BRIDGE AND TUNNEL CENTRES. By JOHN B. McMASTERS, C.E. With Illustrations.
- XXI. SAFETY VALVES. By RICHARD H. BUEL, C.E. With Illustrations.
- XXII. HIGH MASONRY DAMS. By JOHN B. McMASTERS, C.E. With Illustrations.
- XXIII. THE FATIGUE OF METALS under Repeated Strains, with various Tables of Results of Experiments. From the German of Prof. LUDWIG SPANGENBERG. With a Preface by S. H. SHREVE, A.M. With Illustrations.
- XXIV. A PRACTICAL TREATISE ON THE TEETH OF WHEELS, with the theory of the use of Robinson's Odontograph. By S. W. ROBINSON, Prof. of Mechanical Engineering, Illinois Industrial University.
- XXV. THEORY AND CALCULATIONS OF CONTINUOUS BRIDGES. By MANSFIELD MERRIMAN, C.E. With Illustrations.
- XXVI. PRACTICAL TREATISE ON THE PROPERTIES OF CONTINUOUS BRIDGES. By CHARLES BENDER, C.E.

XXVII. ON BOILER INCRUSTATION AND CORROSION. By J. F. Rowan.

XXVIII. ON TRANSMISSION OF POWER BY WIRE ROPE. By Albert W. Stahl.

XXIX. INJECTORS: THEIR THEORY AND USE. Translated from the French of M. Leon Pouchet.

XXX. TERRESTRIAL MAGNETISM AND THE MAGNETISM OF IRON SHIPS. By Professor Fairman Rogers.

XXXI. THE SANITARY CONDITION OF DWELLING HOUSES IN TOWN AND COUNTRY. By George E. Waring, Jr.

♦ ♦ ♦

I N P R E S S .

Heating and Ventilation in its Practical Application for the Use of Engineers and Architects.

Embracing a Series of Tables and Formulæ for dimensions for Heating Flow and Return Pipes, for Steam and Hot Water Boilers, Flues, etc., etc. By F. Schumann, C. E. 1 vol. 12mo. Illustrated.

A Guide to the Determination of Rocks.

Being an Introduction to Lithology. By Edward Jannettaz, Doctuer des Sciences. Translated from the French by Geo. W. Plympton, Professor of Physical Science, Brooklyn Polytechnic Institute. 12mo.

Shield's Treatise on Engineering Construction.

12mo. Cloth.

Embracing Discussions of the Principles involved and Descriptions of the Material employed in Tunnelling, Bridging, Canal and Road Building, etc., etc.

MILITARY BOOKS

PUBLISHED BY

D. VAN NOSTRAND,

23 Murray Street and 27 Warren Street,

NEW YORK.

Any Book in this Catalogue sent free by mail on receipt of price.

Benton's Ordnance and Gunnery.

Fourth Edition, Revised and Enlarged. 8vo. Cloth. \$5.00.

ORDNANCE AND GUNNERY. A Course of Instruction in Ordnance and Gunnery. Compiled for the use of the Cadets of the U. S. Military Academy, by Col. J. G. BENTON, Major Ordnance Dep., late Instructor of Ordnance and Gunnery, Military Academy, West Point. Illustrated.

Holley's Ordnance and Armor.

8vo. Half Roan, \$10.00. Half Russia, \$12.00.

A TREATISE ON ORDNANCE AND ARMOR. With an Appendix, referring to Gun-Cotton, Hooped Guns, etc., etc. By Alexander L. Holley, B. P. With 493 illustrations. 948 pages.

Scott's Military Dictionary.

8vo. Half Roan, \$6.00. Half Russia, \$8.00. Full Morocco, \$10.00.

MILITARY DICTIONARY. Comprising Technical Definitions; Information on Raising and Keeping Troops; Law, Government, Regulation, and Administration relating to Land Forces. By Col. H. L. Scott, U.S.A. 1 vol. Fully illustrated.

Roemer's Cavalry.

8vo. Cloth, \$6.00. Half Calf, \$7.50.

CAVALRY: ITS HISTORY, MANAGEMENT, AND USES IN WAR. By J. Roemer, LL.D., late an officer of Cavalry in the Service of the Netherlands. Elegantly illustrated with one hundred and twenty-seven fine wood engravings. Beautifully printed on tinted paper.

Michaelis' Chronograph.

4to. Illustrated. Cloth. \$3.00.

THE LE BOULENGE CHRONOGRAPH. With three lithographed folding plates of illustrations. By Brevet Capt. O. E. Michaelis, First Lieutenant Ordnance Corps, U. S. Army.

Benet's Chronoscope.

Second Edition. Illustrated. 4to. Cloth. \$3.00.

ELECTRO-BALLISTIC MACHINES., and the Schultz Chronoscope. By Genl. S. V. Benét, Chief of Ordnance, U. S. Army.

Dufour's Principles of Strategy and Grand Tactics.

12mo. Cloth. \$3.00.

THE PRINCIPLES OF STRATEGY AND GRAND TACTICS. Translated from the French of General G. H. Dufour. By William P. Craighill, U. S. Engr., and late Assistant Professor of Engineering, Military Academy, West Point. From the last French edition. Illustrated.

Jomini's Life of the Emperor Napoleon.

4 vols. 8vo., and Atlas. Cloth. Half Calf.

MILITARY AND POLITICAL LIFE OF THE EMPEROR NAPOLEON. By Baron Jomini, General-in-Chief and Aid-de-Camp to the Emperor of Russia. Translated from the French, with Notes, by H. W. Halleck, LL.D., Major-General U. S. Army. With 60 Maps and Plans.

Jomini's Campaign of Waterloo.

Third Edition. 12mo. Cloth. \$1.25.

THE POLITICAL AND MILITARY HISTORY OF THE CAMPAIGN OF WATERLOO. Translated from the French of General Baron de Jomini, by Genl. S. V. Benét, Chief of Ordnance.

Jomini's Grand Military Operations.

2 vols. 8vo., and Atlas. Cloth, \$15.00. Half Calf or Morocco, \$21. Half Russia, \$22.50.

TREATISE ON GRAND MILITARY OPERATIONS. Illustrated by a Critical and Military History of the Wars of Frederick the Great. With a Summary of the Most Important Principles of the Art of War. By Baron de Jomini. Illustrated by Maps and Plans. Translated from the French by Col. S. B. Holabird, A. D. C., U. S. Army.

Rodenbough's Everglade to Canon.

Royal 8vo. Illustrated with Chromo-Lithographs. Extra Cloth. \$7.50.

EVERGLADE TO CANON, with the Second Dragoons (Second U. S. Cavalry), an authentic account of service in Florida, Mexico, Virginia and the Indian Country, including Personal Recollections of Distinguished Officers. By Theo. F. Rodenbough, Colonel and Brevet Brigadier-General, U. S. Army.

History of Brevets.

Crown 8vo. Extra Cloth. \$3.50.

THE HISTORY AND LEGAL EFFECTS OF BREVETS in the Armies of Great Britain and the United States, from the origin in 1692 until the present time. By Gen. James B. Fry, U. S. Army.

Barre Duparcq's Military Art and History.

8vo. Cloth. \$5.00.

ELEMENTS OF MILITARY ART AND HISTORY. By Edward de la Barré Duparcq, Chef de Bataillon of Engineers in the Army of France, and Professor of the Military Art in the Imperial School of St. Cyr. Translated by Colonel Geo. W. Cullum, U. S. E.

Discipline and Drill of the Militia.

Crown 8vo. Flexible cloth. \$2.00.

THE DISCIPLINE AND DRILL OF THE MILITIA. By Major Frank S. Arnold, Assistant Quartermaster-General, Rhode Island.

Wallen's Service Manual.

12mo. Cloth. \$1.50.

SERVICE MANUAL for the Instruction of newly appointed Commissioned Officers, and the Rank and File of the Army, as compiled from Army Regulations, The Articles of War, and the Customs of Service. By Henry D. Wallen, Bvt. Brigadier-General U. S. Army.

Boynton's History of West Point.

Second Edition. 8vo. Fancy Cloth. \$3.50.

HISTORY OF WEST POINT, and its Military Importance during the American Revolution; and the Origin and Progress of the United States Military Academy. By Bvt. Maj. Edward C. Boynton, A. M., Adjutant of the Military Academy. With 36 Maps and Engraving

Wood's West Point Scrap-Book.

8vo. Extra Cloth. \$5.00

THE WEST POINT SCRAP-BOOK. Being a Collection of Legends, Stories, Songs, &c. By Lieut. O. E. Wood, U. S. A. With 69 wood-cut Illustrations. Beautifully printed on tinted paper.

West Point Life.

Oblong 8vo. Cloth, \$2.50.

WEST POINT LIFE. A Poem read before the Dialectic Society of the United States Military Academy. Illustrated with twenty-two full-page Pen and Ink Sketches. By A Cadet. To which is added the song, "Benny Havens, Oh!"

Gillmore's Fort Sumter.

8vo. Cloth. \$10.00. Half Russia, \$12.00.

GILLMORE'S FORT SUMTER. Official Report of Operations against the Defences of Charleston Harbor, 1863. Comprising the descent upon Morris Island, the Demolition of Fort Sumter, and the siege and reduction of Forts Wagner and Gregg. By Maj.-Gen. Q. A. Gillmore, U. S. Engineers. With 76 lithographic plates, views, maps, etc.

Gillmore's Supplementary Report on Fort Sumter.

8vo. Cloth. \$5.00.

SUPPLEMENTARY REPORT to the Engineer and Artillery Operations against the Defences of Charleston Harbor in 1863. By Maj.-Gen. Q. A. Gillmore, U. S. Engineers. With Seven Lithographed Maps and Views.

Gillmore's Fort Pulaski.

8vo. Cloth. \$2.50

SIEGE AND REDUCTION OF FORT PULASKI, GEORGIA. By Maj.-Gen. Q. A. Gillmore, U. S. Engineers. Illustrated by Maps and Views.

Barnard and Barry's Report.

8vo. Cloth. \$4.00.

REPORT OF THE ENGINEER AND ARTILLERY OPERATIONS OF THE ARMY OF THE POTOMAC, from its Organization to the Close of the Peninsular Campaign. By Maj.-Gen. J. G. Barnard, U. S. Engineers, and Maj.-Gen. W. F. Barry, Chief of Artillery. Illustrated by 18 Maps, Plans, &c.

Guide to West Point.

18mo. Flexible Cloth. \$1.00.

GUIDE TO WEST POINT AND THE U. S. MILITARY ACADEMY. With Maps and Engravings.

Barnard's C. S. A., and the Battle of Bull Run.

8vo. Cloth. \$2.00.

THE "C. S. A.," AND THE BATTLE OF BULL RUN. By Maj.-Gen. J. G. Barnard, U. S. Engineers. With five Maps.

Barnard's Peninsular Campaign.

8vo. Cloth. \$1.00. 12mo. Paper 30c.

THE PENINSULAR CAMPAIGN AND ITS ANTECEDENTS, as developed by the Report of Maj.-Gen. Geo. B. McClellan, and other published Documents. By Maj.-Gen. J. G. Barnard, U. S. Engineers.

Barnard's Notes on Sea-Coast Defence.

8vo. Cloth. \$2.00.

NOTES ON SEA-COAST DEFENCE: Consisting of Sea-Coast Fortification; the Fifteen-Inch Gun; and Casemate Embrasure. By Major-Gen. J. G. Barnard, U. S. Engineers. With an engraved Plate of the 15-inch Gun.

Henry's Military Record of Civilian Appointments, U. S. A.

2 Vols. 8vo. Cloth. \$10.00.

MILITARY RECORD OF CIVILIAN APPOINTMENTS IN THE UNITED STATES ARMY. By Guy V. Henry, Brevet-Colonel U. S. A.

Harrison's Pickett's Men.

12mo. Cloth. \$2.00.

PICKETT'S MEN. A Fragment of War History. By Col. Walter Harrison. With portrait of Gen. Pickett.

Todleben's Defence of Sebastopol.

12mo. Cloth. \$2.00.

TODLEBEN'S (GENERAL) HISTORY OF THE DEFENCE OF SEBASTOPOL. By William Howard Russell, LL.D., of the London Times.

Hotchkiss and Allan's Battle of Chancellorsville.

8vo. Cloth. \$5.00.

THE BATTLE-FIELDS OF VIRGINIA. Chancellorsville, embracing the Operations of the Army of Northern Virginia. From the First Battle of Fredericksburg to the Death of Lt.-Gen. T. J. Jackson. By Jed. Hotchkiss and William Allan. Illustrated with five Maps and Portrait of Stonewall Jackson.

Andrews' Campaign of Mobile.

8vo. Cloth. \$3.50.

THE CAMPAIGN OF MOBILE, including the Co-operation of General Wilson's Cavalry in Alabama. By Brevet Maj.-Gen. C. C. Andrews. With five Maps and Views.

Stevens' Three Years in the Sixth Corps.

New and Revised Edition. 8vo. Cloth. \$3.00

THREE YEARS IN THE SIXTH CORPS. A concise narrative of events in the Army of the Potomac from 1861 to the Close of the Rebellion. April, 1865. By Geo. T. Stevens, Surgeon of the 77th Regt. New York Volunteers. Illustrated with 17 engravings and six steel portraits.

Lecomte's War in the United States.

12mo. Cloth. \$1.00.

THE WAR IN THE UNITED STATES. A Report to the Swiss Military Department. By Ferdinand Lecomte, Lieut.-Col. Swiss Confederation. Translated from the French by a Staff Officer.

Roberts' Hand-Book of Artillery.

16mo. Morocco Clasp. \$2.00.

HAND-BOOK OF ARTILLERY. For the service of the United States Army and Militia. Tenth edition, revised and greatly enlarged. By Joseph Roberts, Lt.-Col. 4th Artillery and Brevet. Maj.-General U. S. Army.

Instructions for Field Artillery.

12mo. Cloth. \$3.00.

INSTRUCTIONS FOR FIELD ARTILLERY. Prepared by a Board of Artillery Officers. To which is added the "Evolutions of Batteries," translated from the French, by Brig.-Gen. R. Anderson, U. S. A. 122 plates.

Heavy Artillery Tactics.

12mo. Cloth. \$2.50.

HEAVY ARTILLERY TACTICS.—1863. Instructions for Heavy Artillery; prepared by a Board of Officers, for the use of the Army of the United States. With service of a gun mounted on an iron carriage and 39 plates.

Andersons' Evolutions of Field Artillery.

24mo. Cloth. \$1.00.

EVOLUTIONS OF FIELD BATTERIES OF ARTILLERY. Translated from the French, and arranged for the Army and Militia of the United States. By Gen. Robert Anderson, U. S. A. Published by order of the War Department. 33 plates.

Duane's Manual for Engineering Troops.

12mo. Half Morocco. \$2.50.

MANUAL FOR ENGINEER TROOPS : Consisting of—Part I. Ponton Drill; II. Practical Operations of a Siege; III. School of the Sap; IV. Military Mining; V. Construction of Batteries. By General J. C. Duane, Corps of Engineers, U. S. Army. With 16 plates and numerous wood-cut illustrations.

Cullum's Military Bridges.

8vo. Cloth. \$3.50.

SYSTEMS OF MILITARY BRIDGES, in use by the United States Army; those adopted by the Great European Powers; and such as are employed in British India. With Directions for the Preservation, Destruction, and Re-establishment of Bridges. By Col. George W. Cullum, U. S. E. With 7 folding plates.

Mendell's Military Surveying.

12mo. Cloth. \$2.00.

A TREATISE ON MILITARY SURVEYING. Theoretical and Practical, including a description of Surveying Instruments. By G. H. Mendell, Major of Engineers. With 70 wood-cut illustrations.

Abbot's Siege Artillery Against Richmond.

8vo. Cloth. \$3.50.

SIEGE ARTILLERY IN THE CAMPAIGN AGAINST RICHMOND. By Henry L. Abbot, Major of U. S. Engineers. Illustrated.

Haupt's Military Bridges.

8vo. Cloth. \$6.50.

MILITARY BRIDGES; For the Passage of Infantry, Artillery and Baggage Trains; with suggestions of many new expedients and constructions for crossing streams and chasms. Including also designs for Trestle and Truss-Bridges for Military Railroads, adapted specially to the wants of the Service of the United States. By Herman Haupt, Brig.-Gen. U. S. A., author of "General Theory of Bridge Constructions," &c. Illustrated by 69 lithographic engravings.

Lendy's Maxims and Instructions on the Art of War.

18mo. Cloth. 75c.

MAXIMS AND INSTRUCTIONS ON THE ART OF WAR. A Practical Military Guide for the use of Soldiers of All Arms and of all Countries. Translated from the French by Captain Lendy, Director of the Practical Military College, late of the French Staff, etc., etc.

Benet's Military Law and Courts-Martial.

Sixth Edition, Revised and Enlarged. 8vo. Law Sheep. \$4.50.

BENET'S MILITARY LAW. A Treatise on Military Law and the Practice of Courts-Martial. By Gen. S. V. Benet, Chief of Ordnance U. S. A., late Assistant Professor of Ethics, Law, &c., Military Academy, West Point.

Lippitt's Special Operations of War.

Illustrated. 18mo. Cloth. \$1.00.

Lippitt's Field Service in War.

12mo. Cloth. \$1.00.

Lippitt's Tactical Use of the Three Arms.

12mo. Cloth. \$1.00.

Lippitt on Intrenchments.

41 Engravings. 12mo. Cloth. \$1.25.

Kelton's New Bayonet Exercise.

Fifth Edition. Revised. 12mo. Cloth. \$2.00.

NEW BAYONET EXERCISE. A New Manual of the Bayonet, for the Army and Militia of the United States. By General J. C. Kelton, U. S. A. With 40 beautifully engraved plates.

Craighill's Army Officers' Companion.

18mo. Full Roan. \$2.00.

THE ARMY OFFICERS' POCKET COMPANION. Principally designed for Staff Officers in the Field. Partly translated from the French of M. de Rouvre, Lieut.-Col. of the French Staff Corps, with additions from Standard American, French, and English authorities. By Wm. P. Craighill, Major U. S. Corps of Engineers, late Assistant Professor of Engineering at the U. S. Military Academy, West Point.

Casey's U. S. Infantry Tactics.

3 vols. 24mo. Cloth. \$2.50.

U. S. INFANTRY TACTICS. By Brig.-Gen. Silas Casey, U. S. A. 3 vols., 24mo. Vol. I.—School of the Soldier; School of the Company; Instruction for Skirmishers. Vol. II.—School of the Battalion. Vol. III.—Evolutions of a Brigade; Evolutions of a Corps d'Armée. Lithographed plates.

United States Tactics for Colored Troops.

24mo. Cloth. \$1.50.

U. S. TACTICS FOR COLORED TROOPS. U. S. Infantry Tactics for the use of the Colored Troops of the United States Infantry. Prepared under the direction of the War Department.

Morris' Field Tactics for Infantry.

Illustrated. 18mo. Cloth. 75c.

FIELD TACTICS FOR INFANTRY. By Brig.-Gen. Wm. H. Morris, U. S. Vols., late Second U. S. Infantry.

Monroe's Light Infantry and Company Drill.

32mo. Cloth. 75c.

LIGHT INFANTRY COMPANY AND SKIRMISH DRILL. Bayonet Fencing; with a Supplement on the Handling and Service of Light Infantry. By J. Monroe, Col. Twenty-Second Regiment, N. G., N. Y. S. M. formerly Captain U. S. Infantry.

Berriman's Sword Play.

Fourth Edition. 12mo. Cloth. \$1.00.

SWORD-PLAY. The Militiaman's Manual and Sword-Play without a Master. Rapier and Broad-Sword Exercises, copiously explained and illustrated; Small-Arm Light Infantry Drill of the United States Army; Infantry Manual of Percussion Musket; Company Drill of the United States Cavalry. By Major M. W. Berriman.

Morris' Infantry Tactics.

2 vols. 24mo. \$2.00. 2 vols. in 1. Cloth. \$1.50.

INFANTRY TACTICS. By Brig.-Gen. William H. Morris, U. S. Vols., and late U. S. Second Infantry.

Le Gal's School of the Guides.

16mo. Cloth. 60c.

THE SCHOOL OF THE GUIDES. Designed for the use of the Militia of the United States. By Col. Eugene Le Gal.

Duryea's Standing Orders of the Seventh Regiment.

New Edition. 16mo. Cloth. 50c.

STANDING ORDERS OF THE SEVENTH REGIMENT NATIONAL GUARDS. By A. Duryea, Colonel.

Heth's System of Target Practice.

18mo. Cloth. 75c.

SYSTEM OF TARGET PRACTICE ; For the use of Troops when armed with the Musket, Rifle-Musket, Rifle, or Carbine. Prepared principally from the French, by Captain Henry Heth, Tenth Infantry, U. S. A.

Wilcox's Rifles and Rifle Practice.

New Edition. Illustrated. 8vo. Cloth. \$2.00.

RIFLES AND RIFLE PRACTICE. An Elementary Treatise on the Theory of Rifle Firing ; with descriptions of the Infantry Rifles of Europe and the United States, their Balls and Cartridges. By Captain C. M. Wilcox, U. S. A.

Viele's Hand-Book for Active Service.

12mo. Cloth. \$1.00.

HAND-BOOK FOR ACTIVE SERVICE, containing Practical Instructions in Campaign Duties. For the use of Volunteers. By Brig.-Gen. Egbert L. Viele, U. S. A.

Nolan's System for Training Cavalry Horses.

24 Plates. Cloth. \$2.00.

NOLAN'S SYSTEM FOR TRAINING CAVALRY HORSES. By Kenner Garrard, Bvt. Brig.-Gen. U. S. A.

Arnold's Cavalry Service.

Illustrated 18mo. Cloth. 75c.

NOTES ON HORSES FOR CAVALRY SERVICE, embodying the Quality, Purchase, Care, and Diseases most frequently encountered, with lessons for biting the Horse, and bending the neck. By Bvt. Major A. K. Arnold, Capt. Fifth Cavalry, Assistant Instructor of Cavalry Tactics, U. S. Mil. Academy.

Cooke's Cavalry Practice.

100 Illustrations. 12mo. Cloth. \$1.00.

CAVALRY TACTICS; Regulations for the Instruction, Formation and Movements of the Cavalry of the Army and Volunteers of the United States. By Philip St. George Cooke, Brig.-Gen. U. S. A.

This is the edition now in use in the U. S. Army.

Patten's Cavalry Drill.

93 Engravings. 12mo. Paper. 50c.

CAVALRY DRILL. Containing Instructions on Foot; Instructions on Horseback; Basis of Instruction; School of the Squadron, and Sabre Exercise.

Patten's Infantry Tactics.

92 Engravings. 12mo. Paper. 50c.

INFANTRY TACTICS. School of the Soldier; Manual of Arms for the Rifle Musket; Instructions for Recruits, School of the Company; Skirmishers, or Light Infantry and Rifle Company Movements; the Bayonet Exercise; the Small-Sword Exercise; Manual of the Sword or Sabre.

Patten's Infantry Tactics.

Revised Edition. 100 Engravings. 12mo. Paper. 75c.

INFANTRY TACTICS. Contains Nomenclature of the Musket; School of the Company; Skirmishers, or Light Infantry and Rifle Company Movements; School of the Battalion; Bayonet Exercise; Small Sword Exercise; Manual of the Sword or Sabre.

Patten's Army Manual.

8vo. Cloth. \$2.00.

ARMY MANUAL. Containing Instructions for Officers in the Preparation of Rolls, Returns, and Accounts required of Regimental and Company Commanders, and pertaining to the Subsistence and Quartermaster's Department, &c., &c.

Patten's Artillery Drill.

12mo. Paper. 50c.

ARTILLERY DRILL. Containing instruction in the School of the Piece, and Battery Manœuvres, compiled agreeably to the Latest Regulations of the War Department. From Standard Military Authority. By George Patten, late U. S. Army.

Andrews' Hints to Company Officers.

18mo. Cloth. 60c.

HINTS TO COMPANY OFFICERS ON THEIR MILITARY DUTIES. By General C. C. Andrews, Third Regt., Minnesota Vols.

Thomas' Rifled Ordnance.

Fifth Edition, Revised. Illustrated. 8vo. Cloth. \$2.00.

RIFLED ORDNANCE; A Practical Treatise on the Application of the Principle of the Rifle to Guns and Mortars of every calibre. To which is added a new theory of the initial action and force of Fired Gunpowder. By Lynall Thomas, F. R. S. L.

Brinkerhoff's Volunteer Quartermaster.

12mo. Cloth. \$2.50.

THE VOLUNTEER QUARTERMASTER. By Captain R. Brinkerhoff, Post Quartermaster at Washington.

Hunter's Manual for Quartermasters and Commissaries.

12mo. Cloth. \$1.25. Flexible Morocco, \$1.50.

MANUAL FOR QUARTERMASTERS AND COMMISSARIES. Containing Instructions in the Preparation of Vouchers, Abstracts, Returns, etc. By Captain R. F. Hunter, late of the U. S. Army. 12mo. Cloth. \$1.25.

Greener's Gunnery.

8vo. Cloth. \$4.00. Full Calf. \$6.00.

GUNNERY IN 1858. A Treatise on Rifles, Cannon, and Sporting Arms. By Wm. Greener, R. C. E.

Head's System of Fortifications.

Illustrated. 4to. Paper. \$1.00.

A NEW SYSTEM OF FORTIFICATIONS. By George E. Head, A. M., Capt. Twenty-Ninth Infantry, and Bvt. Major U. S. A.

* **Experiments on Metal for Cannon,**

4to. 25 Plates. Cloth. \$10.00.

REPORTS OF EXPERIMENTS ON THE STRENGTH AND OTHER PROPERTIES OF METALS FOR CANNON; with a Description of the Machines for Testing Metals, and of the Classification of Cannon in Service. By Officers of the Ordnance Department U. S. Army. Published by authority of the Secretary of War.

Rodman's Experiments on Metals for Cannon and Powder.

4to. 60 Plates. Cloth. \$10.00.

REPORTS OF EXPERIMENTS ON THE PROPERTIES OF METALS FOR CANNON AND THE QUALITIES OF CANNON POWDER; with an Account of the Fabrication and Trial of a 15-inch Gun. By Captain T. J. Rodman, of the Ordnance Department of U. S. Army. Published by authority of the Secretary of War.

Norton's Report on the Munitions of War.

80 Illustrations. 8vo. Cloth. Extra. \$3.50.

REPORT TO THE GOVERNMENT OF THE UNITED STATES ON THE MUNITIONS OF WAR exhibited at the Paris Universal Exhibition, 1867. By Charles B. Norton, U. S. V., and W. J. Valentine, Esq., U. S. Commissioners.

Lieber's Instructions for Armies.

12mo. Paper. 25 cents.

INSTRUCTIONS FOR THE GOVERNMENT OF ARMIES OF THE U. S. IN THE FIELD. Prepared by Francis Lieber, LL.D.

Ordronaux's Manual for Military Surgeons.

12mo. Half Morocco. \$1.50.

MANUAL OF INSTRUCTIONS FOR MILITARY SURGEONS, in the Examination of Recruits and Discharge of Soldiers. Prepared at the request of the United States Sanitary Commission. By John Ordranax, M.D., Professor of Medical Jurisprudence in Columbia College, New York.

The Automaton Company.

In Box \$1.25. When sent by mail \$1.94.

THE AUTOMATON COMPANY; OR, INFANTRY SOLDIERS' PRACTICAL INSTRUCTOR. For all Company Movements in the Field. By G. Douglas Brewerton, U. S. Army.

The Automaton Battery.

In Box \$1.00. When sent by mail \$1.30.

THE AUTOMATON BATTERY; OR, ARTILLERIST'S PRACTICAL INSTRUCTOR. For all Mounted Artillery Manœuvres in the Field. By G. Douglas Brewerton, U. S. A.

The Automaton Regiment.

In Box \$1.00. When sent by mail \$1.30.

THE AUTOMATON REGIMENT; OR, INFANTRY SOLDIERS' PRACTICAL INSTRUCTOR. For all Regimental Movements in the Field. By G. Douglas Brewerton, U. S. A.

Grafton on the Camp and March.

12mo. Cloth. 75c.

A TREATISE ON THE CAMP AND MARCH. With which is connected the Construction of Field-Works and Military Bridges. By Captain Henry D. Grafton, U. S. A.

Gen. McClellan's Report of the Army of the Potomac.

8vo. Cloth. \$1.00. Paper. 50 cents.

REPORT OF THE ARMY OF THE POTOMAC, of its operations while under his command. With Maps and Plans. By General Geo. B. McClellan, U. S. A.

Moore's Portrait Gallery of the War.

1 vol. 8vo. Cloth. \$6.00. Half Calf. \$7.50.

PORTRAIT GALLERY OF THE WAR, CIVIL, MILITARY, AND NAVAL. A Biographical Record. Edited by Frank Moore. Illustrated with 60 fine portraits on steel.

Butler's Projectiles and Rifled Cannon.

4to. 36 Plates. Cloth. \$7.50.

PROJECTILES AND RIFLED CANNON. A Critical Discussion of the Principal Systems of Rifling and Projectiles, with practical suggestions for their improvement, as embraced in a report to the Chief of Ordnance, U. S. Army. By Capt. John S. Butler, Ordnance Corps, U. S. A.

Sergeant's Roll Book.

Pocket-book form. \$1.25.

SERGEANT'S ROLL BOOK, FOR THE COMPANY, DETAIL AND SQUAD.

NAVAL BOOKS

PUBLISHED BY

D. VAN NOSTRAND

23 Murray Street & 27 Warren Street,
NEW YORK.

Luce's Seamanship.

Fourth Edition. Crown 8vo. Revised and Improved. Illustrated by 89 full-page copper-plate engravings. 8vo. Half Roan. \$7.50.

SEAMANSHIP. For the use of the United States Naval Academy. By Capt. S. B. Luce, U. S. N. 1 vol., crown octavo.

 Text-Book at the U. S. Naval Academy, Annapolis.

Barnes' Submarine Warfare.

With 20 Lithographic Plates, and many Wood-cuts. 8vo. Cloth. \$5.00.

SUBMARINE WARFARE, DEFENSIVE AND OFFENSIVE. Comprising a Full and complete History of the invention of the Torpedo, its employment in War, and results of its use. Descriptions of the various forms of Torpedoes, Submarine Batteries and Torpedo Boats actually used in War. By Lieut.-Commander John S. Barnes, U. S. N.

Jeffers' Nautical Surveying.

Illustrated with 9 Copperplates and 31 Wood-cut Illustrations. 8vo. Cloth. \$5.00.

NAUTICAL SURVEYING. By William N. Jeffers, Captain U. S. Navy.

Coffin's Navigation.

Fifth Edition. 12mo. Cloth. \$3.50.

NAVIGATION AND NAUTICAL ASTRONOMY. Prepared for the use of the U. S. Naval Academy. By J. H. C. Coffin, Prof. of Astronomy, Navigation and Surveying, with 52 wood-cut illustrations.

Text Book of Surveying.

8vo. 9 Lithograph Plates and several Wood-cuts. Illustrated: Cloth. \$2.00.

A Text Book on Surveying, Projections and Portable Instruments for the use of the Cadet Midshipmen at the U. S. Naval Academy.

Clark's Navigation.

Illustrated. 8vo. Cloth. \$3.00.

THEORETICAL NAVIGATION AND NAUTICAL ASTRONOMY. By Lewis Clark, Lieut.-Commander U. S. Navy.

Simpson's Ordnance and Naval Gunnery.

Fifth Edition, Revised and Enlarged. Illustrated with 185 Engravings. 8vo. Cloth. \$5.00.

A TREATISE ON ORDNANCE AND NAVAL GUNNERY. Compiled and arranged as a Text-Book for the U. S. Naval Academy, by Commauder Edward Simpson, U. S. N.

Young Seaman's Manual.

8vo. Half Roan. \$3.00.

THE YOUNG SEAMAN'S MANUAL. Compiled from various authorities, and illustrated with numerous original and select designs. For the use of the U. S. Training Ships and the Marine Schools.

Harwood's Naval Courts-Martial.

8vo. Law-sheep. \$4.00.

LAW AND PRACTICE OF UNITED STATES NAVAL COURTS-MARTIAL. By A. A. Harwood, U. S. N. Adopted as a Text-Book at the U. S. Naval Academy.

Parker's Squadron Tactics.

Illustrated by 77 Plates. 8vo. Cloth. \$5.00.

SQUADRON TACTICS UNDER STEAM. By Foxhall A. Parker, Commo-
dore U. S. Navy. Published by authority of the Navy Department.

Parker's Fleets of the World.

8vo. 9 Illustrations. Cloth, extra. \$5.00

THE FLEETS OF THE WORLD. The Galley Period. By Foxhall A. Parker,
Commodore U. S. Navy.

Parker's Fleet Tactics.

18mo. Cloth. \$2.50.

FLEET TACTICS UNDER STEAM. By Foxhall A. Parker, Commodore
U. S. Navy. Illustrated by 140 wood-cuts.

Parker's Naval Howitzer Ashore.

26 Plates. 8vo. Cloth. \$4.00.

THE NAVAL HOWITZER ASHORE. By Foxhall A. Parker, Commo-
dore U. S. Navy. With plates. Approved by the Navy Department.

Parker's Naval Howitzer Afloat.

32 Plates. 8vo. Cloth. \$4.00.

THE NAVAL HOWITZER AFLOAT. By Foxhall A. Parker, Commo-
dore U. S. Navy. With plates. Approved by the Navy Department.

Brandt's Gunnery Catechism.

Revised Edition. Illustrated. 18mo. Cloth. \$1.50.

GUNNERY CATECHISM. As applied to the service of the Naval Ord-
nance. Adapted to the latest Official Regulations, and approved by
the Bureau of Ordnance, Navy Department. By J. D. Brandt, for-
merly of the U. S. Navy.

**Ordnance Instructions for the United States
Navy.**

Illustrated. 8vo. Cloth. \$5.00.

ORDNANCE INSTRUCTIONS FOR THE UNITED STATES NAVY. Part I.
Relating to the Preparation of Vessels of War for Battle, and to the
Duties of Officers and others when at Quarters. Part II. The Equip-
ment and Manœuvre of Boats, and Exercise of Howitzers. Part III.
Ordnance and Ordnance Stores. Published by order of the Navy De-
partment.

Barrett's Gunnery Instructions.

12mo. Cloth. \$1.25.

GUNNERY INSTRUCTIONS. By Capt. Edward Barrett, U. S. N., Instructor
of Gunnery, Navy Yard, Brooklyn.

Buckner's Tables of Ranges.

8vo. Cloth. \$1.50

CALCULATED TABLES OF RANGES FOR NAVY AND ARMY GUNS. By
Lieut. W. P. Buckner, U. S. N.

Luce's Naval Light Artillery.

22 Plates. 8vo. Cloth \$3.00.

NAVAL LIGHT ARTILLERY. By Lieutenant W. H. Parker, U. S. N.
Third Edition, revised by Lieut. S. B. Luce, Assistant Instructor of
Gunnery and Tactics at the United States Naval Academy.

Manual of Boat Exercise.

18mo. Flexible Cloth. 75c.

MANUAL OF THE BOAT EXERCISE at the U. S. Naval Academy, designed
for the practical instruction of the Senior Class in Naval Tactics.

Hamersly's Records of Living Officers of the U. S. Navy.

Revised Edition. Cloth. 8vo. \$5.00.

THE RECORDS OF LIVING OFFICERS OF THE U. S. NAVY AND MARINE CORPS. Compiled from Official Sources. By Lewis B. Hamersly, late Lieutenant U. S. Marine Corps.

Levy's Rules and Regulations for Men-of-War.

Third Edition, Revised and Enlarged. 18mo. Flexible Cloth. 50c.

MANUAL OF INTERNAL RULES AND REGULATIONS FOR MEN-OF-WAR. By Commodore U. P. Levy, U. S. N.

Pook's Shipbuilding.

8vo. Cloth. \$5.00

A METHOD OF COMPARING THE LINES AND DRAUGHTING VESSELS PROPELLED BY SAIL OR STEAM, including a Chapter on Laying off on the Mould-Loft Floor. By Samuel M. Pook, Naval Constructor. With Illustrations.

Osbon's Hand-Book of the United States Navy.

12mo. Cloth. \$3.00.

HAND-BOOK OF THE UNITED STATES NAVY. Being a compilation of all the principal events in the history of every vessel of the United States Navy from April, 1861, to May, 1864. Compiled and arranged by B. S. Osbon.

Totten's Naval Text-Book.

Second and Revised Edition. 12mo. Cloth. \$3.00.

NAVAL TEXT-BOOK. Naval Text-Book and Dictionary, compiled for the use of Midshipmen of the U. S. Navy. By Commander B. J. Totten, U. S. N.

Roe's Naval Duties.

12mo. Cloth. \$1.50.

NAVAL DUTIES AND DISCIPLINE: With the Policy and Principles of Naval Organization. By F. A. Roe, late Commander U. S. Navy.

Stuart's Naval Dry Docks.

Fourth Edition. 4to. Cloth. \$6.00.

THE NAVAL DRY DOCKS OF THE UNITED STATES. By Gen. C. B. Stuart. Illustrated with 24 fine engravings on steel.

Murphy and Jeffer's Nautical Route.

8vo. Cloth. \$2.50.

NAUTICAL ROUTINE AND STOWAGE. With Short Rules in Navigation.
By John McLeod Murphy and Wm. N. Jeffers, Jr., U. S. N.

Barrett's Dead Reckoning.

8vo. Flexible Cloth. \$1.25.

DEAD RECKONING; Or, Day's Work. By Edward Barrett, U. S. Navy.

Our Naval School and Naval Officers.

12mo. Cloth. 75c.

A GLANCE AT THE CONDITION OF THE FRENCH NAVY PRIOR TO THE
FRANCO-GERMAN WAR. Translated from the French of M. De Crise-
noy by Commander R. W. Meade, U. S. N.

Ward's Naval Tactics.

8vo. Cloth. \$3.00.

MANUAL OF NAVAL TACTICS: Together with a Brief Critical Analysis
of the Principal Modern Naval Battles. By James H. Ward, Com-
mander U. S. N. With an Appendix, being an extract from Sir How-
ard Douglas's "Naval Warfare with Steam."

Ward's Naval Ordnance.

8vo. Cloth. \$2.00.

ELEMENTARY INSTRUCTION IN NAVAL ORDNANCE AND GUNNERY. By
James H. Ward, Commander U. S. Navy.

Ward's Steam for the Million.

8vo. Cloth. \$1.00.

STEAM FOR THE MILLION. A Popular Treatise on Steam and its Appi-
cation to the Useful Arts, especially to Navigation. By J. H. Ward,
Commander U. S. Navy.

Walker's Screw Propulsion.

8vo. Cloth. 75 cents.

NOTES ON SCREW PROPULSION, its Rise and History. By Capt. W. H.
Walker, U. S. Navy.

RECENT WORKS.

Fanning's Water Supply Engineering.

8vo. 650 pages. 180 Illustrations. Extra cloth. \$6.00.

A PRACTICAL TREATISE ON WATER SUPPLY ENGINEERING. Relating to the Hydrology, Hydrodynamics, and Practical Construction of Water Works, in North America. With numerous Tables and Illustrations. By J. T. Fanning, C. E.

Clark's Complete Book of Reference for Mechanical Engineering.

1012 pages. 8vo. Cloth, \$7.50. Half morocco. \$10.00.

A MANUAL OF RULES, TABLES AND DATA FOR MECHANICAL ENGINEERS. Based on the most recent investigations. By Daniel Kinnear Clark. Illustrated with numerous diagrams.

Mott's Chemists Manual.

650 pages. 8vo. Cloth. \$6.00.

A PRACTICAL TREATISE ON CHEMISTRY (Qualitative and Quantitative Analysis), Stoichiometry, Blowpipe Analysis, Mineralogy, Assaying, Pharmaceutical Preparations, Human Secretions, Specific Gravities, Weights and Measures, etc., etc., etc. By Henry A. Mott, Jr., E. M., Ph. D.

Weyrauch on Iron and Steel Constructions.

12mo. Cloth. \$1.00.

STRENGTH AND CALCULATION OF DIMENSIONS OF IRON AND STEEL CONSTRUCTIONS, with reference to the latest experiments. By J. J. Weyrauch, Ph. D., Professor Polytechnic School of Stuttgart, with four folding plates.

Osburn's Beilsteins' Chemical Analysis.

12mo. Cloth. 75 cents.

An Introduction to Chemical Qualitative Analysis.

By F. BEILSTEIN. Third edition, translated by I. J. OSBUN.

Davis and Rae's Hand Book of Electrical Diagrams.

Oblong 8vo. Extra cloth. \$2.00.

HAND BOOK OF ELECTRICAL DIAGRAMS AND CONNECTIONS. By Charles H. Davis and Frank B. Rae, Illustrated with 32 full page illustrations. Second edition.

M



THIS BOOK IS DUE ON THE LAST DATE
STAMPED BELOW

AN INITIAL FINE OF 25 CENTS

WILL BE ASSESSED FOR FAILURE TO RETURN
THIS BOOK ON THE DATE DUE. THE PENALTY
WILL INCREASE TO 50 CENTS ON THE FOURTH
DAY AND TO \$1.00 ON THE SEVENTH DAY
OVERDUE.

OCT 9 1936

OCT 10 1936

FEB 22 1937

FEB 25 1955

FEB 4 1955 LU

APR 16 1970 49

APR 2 1970

T1034

F2

Fanning

14611

