

Woods Hole Oceanographic Institution

DOCUMENT COLLECTION

PRELIMINARY DESIGN

OF A

CABLE-TOWED

OCEANOGRAPHIC INSTRUMENTATION

SYSTEM

Prepared under Contract Nonr 3201(00)

Sponsored by the
Office of Naval Research

SYSTEMS ENGINEERING DIVISION
PNEUMODYNAMICS CORPORATION
BETHESDA, MARYLAND

A SUBSIDIARY OF
CLEVELAND PNEUMATIC INDUSTRIES, INC.

GC
41
.E4
1961

able-towed
system.

(4-2)

RETURNED

11/25/61
11/10/62
11/8/63
27 Feb 1964

MBL/WHOI



0 0301 0041524 6

PRELIMINARY DESIGN OF A CABLE-TOWED
OCEANOGRAPHIC INSTRUMENTATION
SYSTEM

Prepared under Contract NONr 3201(00)
Sponsored by
The Office of Naval Research

February 1961

Reproduction in whole or in part is
permitted for any purpose of the
United States Government

Prepared by: W. M. Ellsworth
W. M. Ellsworth
Manager, Marine Systems Department

S. M. Gay
S. M. Gay
Project Manager

Approved by: R. V. Hensley
R. V. Hensley
Director of Engineering

SYSTEMS ENGINEERING DIVISION
PNEUMODYNAMICS CORPORATION
Bethesda, Maryland

A Subsidiary of
CLEVELAND PNEUMATIC INDUSTRIES, INC.

TABLE OF CONTENTS

	<u>Page</u>
ACKNOWLEDGMENTS.....	1
SUMMARY.....	2
INTRODUCTION.....	3
REQUIREMENTS FOR DEEP-TOWED INSTRUMENTATION SYSTEM.....	7
SYSTEM DESCRIPTION.....	11
SYSTEM DESIGN.....	14
SYSTEM CONSIDERATIONS.....	15
COMPONENT SELECTION AND DESIGN.....	16
Selection of Cable Type.....	16
Selection of Cable Size and Downforce.....	22
Design of the Towed Body.....	25
Effect of Variation in Speed and Cable Length.....	31
Cable Fairing.....	37
Design of the Instrument Housings.....	41
Shipboard Handling Equipment.....	44
Instrumentation.....	53
DISCUSSION.....	55
CONCLUSIONS AND RECOMMENDATIONS.....	60
APPENDIX I: PRELIMINARY DESIGN OF A DEPRESSOR FOR THE TOWED, VERTICAL-INSTRUMENTATION ARRAY.....	62
INTRODUCTION.....	63
HYDRODYNAMIC DESIGN.....	65

TABLE OF CONTENTS (continued)

	<u>Page</u>
APPENDIX II: INSTRUMENTATION FOR MEASUREMENT OF TEMPERATURE PROFILE.....	79
INTRODUCTION.....	80
SHIPBOARD EQUIPMENT.....	84
GAGE PACKAGES.....	89
REFERENCES.....	94

LIST OF ILLUSTRATIONS

<u>Figure</u>		<u>Page</u>
1.	Comparison of Requirements for Faired and Unfaired Cable to Reach a Depth of 5000 feet....	20
2.	Effect of Towing Speed, U, on Required Downforce, T_0 , and Cable Diameter, d.....	23
3.	Vertical Profile Instrumentation Depressor.....	27
4.	Computed Variation of Downforce (L_0), Drag (D), and Downforce-to-Drag Ratio ($\theta = \arctan L_0/D$) as a Function of Towing Velocity.....	29
5.	Effect of Towing Speed, U, on Depth, y, Cable Length, S, and Horizontal Displacement of Towed Body, X, for a Constant Tension at Top....	32
6.	Effect of Towing Speed, U, on Depth, y, Tension at Top, T_1 , and Horizontal Displacement of Towed Body, X, for a Cable Length of 1000 feet..	33
7.	Effect of Towing Speed, U, on Depth, y, Tension at Top, T_1 , and Horizontal Displacement of Towed Body, X, for a Cable Length of 6000 feet...	35
9.	Double-Armor Cable with Clip-Type Fairing.....	38
10.	Armored Cable Sectionalizing Assembly.....	43
11.	Twin load-drum.....	46
12.	Class D, Type D-VA-72, "Caterpuller".....	48
13.	Generalized Design of a Cable-Towed Instrumentation System.....	57
14.	Temperature Profile Instrumentation - Block Diagram.....	82
15.	Shipboard Equipment.....	85
16.	Temperature Measuring Gage Package.....	90

ACKNOWLEDGMENTS

The Authors are deeply indebted to: LCDR. E. W. Sapp for his encouragement and enthusiastic support of this effort; Mr. Ralph Lane for the basic design of the instrument circuitry; Mr. H. M. Fitzpatrick and Mr. D. C. Pauli for their critical review and many contributions; Mr. P. D. Fisher for his contribution to the design of the towed depressor; and Dr. Edgar Bowles and Mrs. Betty Singer for editing and preparing the manuscript for publication.

SUMMARY

A cable-towed instrumentation system, capable of measuring and continuously recording data from oceanic depths as great as 5000 feet is described. General system design is outlined, with particular attention paid to contrasting requirements for faired- and unfaired-cable systems. The hydromechanical design for a depressor is included, as well as the detailed arrangements for a typical temperature-recording system.

INTRODUCTION

INTRODUCTION

There is a serious need for improvement in techniques of acquiring and recording oceanographic data. Improvements in both the quantity and quality of such data are needed, as well as extension of the range of depths to which measurements can be taken. This is particularly true with respect to measurement of temperature distribution.

An obvious method for increasing the rate (and thus the quantity) of data acquisition consists of spacing appropriate measuring devices at intervals along a line normal to the surface of the water, and then moving the entire array through the area of interest, continually monitoring the instrumentation. Several systems based on this principle have been designed, the best known being the "thermistor chain"(2)¹ developed by the Commercial Engineering Company in conjunction with the Woods Hole Oceanographic Institute.

While these systems represent a significant technological advance, the extreme weight and bulk involved to attain

¹ Numbers in parentheses refer to the list of references on page 94.

depths of about 1000 feet preclude extension to major depths. The Systems Engineering Division, sponsored by the Office of Naval Research, therefore undertook a program to increase the capabilities of such systems by designing to the practical maximum limits possible within the envelope of pertinent restrictions. The program had the following general objectives:

1. Study the requirements for deep-towed, continuous-reading oceanographic instrumentation and develop design criteria;
2. Conduct experimental verification of techniques necessary to implement the above design criteria; and
3. Conceptually design and prepare specifications for systems functional at 5000-foot and 1000-foot depths, including shipboard handling equipment.

It soon became apparent that the most expeditious approach to these objectives was to proceed with the conceptual design of the deeper of the two systems, as this would assure early recognition of relevant problems and force development of pertinent design criteria. Moreover, it was decided that whereas provision could not be made for every measurement that might be desired by oceanographers for specific investigations, the design should be directed toward satisfying

the need for temperature measurements in the vertical profile, as the thermal structure of the ocean is of direct and continuing interest in nearly every branch of oceanography.

The major result of this work consists of the conceptual design and specification for a cable-towed oceanographic instrument system suitable for simultaneously positioning measuring devices at discrete depth intervals to 5000 feet. The requirements and pertinent design criteria are contained in a general description of the development of this system. It should be noted that, although directed toward temperature measurements, the design is sufficiently flexible to accommodate any measurement for which suitably miniaturized in situ measurement devices exist. The volume of the instrument containers and the spacing along the tow wire can be varied to accommodate special requirements.

Feasibility of the major concepts has been demonstrated by carrying out necessary preliminary design. Certain critical components have been breadboarded and subjected to sufficient test to demonstrate validity. Details are reported in the appropriate sections of the report.

Finally, those problems which have not been completely resolved are discussed, and a recommended program for future action is given.

REQUIREMENTS FOR DEEP-TOWED INSTRUMENTATION SYSTEM

REQUIREMENTS FOR DEEP-TOWED INSTRUMENTATION SYSTEM

To establish the range of requirements for the system under consideration, personnel of five of the major oceanographic facilities in the United States were interrogated with respect to their future plans and needs. Although unanimity of need was not expected, the results indicate that a more significant range of immediate and near future needs can be satisfied by a versatile instrument support system than was at first believed possible. The major conclusions drawn from these visits are summarized below:

1. The oceanographic laboratories require deep-towed-instrumentation capability. About equal need was expressed for moderate speed (6-8 knots) very deeply towed systems, and shallow (1000-foot) intermediate speed (8-10 knots) systems suitable for fine-scale definition. A maximum depth of 5000 feet appears to cover the area of greatest interest, as this encompasses the deep sound channel and the regions with the greatest variation in physical characteristics.
2. The system should be adaptable for use with many different sensing devices and recording systems; it is essential that there be considerable flexibility in locating the sensors along the cable.

Considerable emphasis must be placed on minimizing size and weight, particularly in the handling equipment, since the capacity of many oceanographic vessels is already overtaxed. The maximum weight of a depressor should not exceed 1000 pounds to minimize handling problems.

3. The system should be operable with or without instrument modules.
4. The system should be capable of a wide variety of measurements. Measurement of temperature is of greatest immediate concern although provision must be made for measurements of conductivity, salinity, and oxygen content.
5. Emphasis at present should be placed on the attainment of desired depths and speeds with a reliable hydromechanical system not posing unreasonable problems in shipboard handling. Final selection of intelligence-transmission techniques should be deferred, although telemetry seems the only practical system for the depths and degree of coverage desired.

The major premise to be drawn from these discussions is that whereas it appears practical to adapt the towing system to a wide range of applications, demonstration of the

feasibility of attaining the desired range of speed and depths with a system which does not impose unreasonable shipboard handling requirements if of first concern. This premise was accordingly adopted as the working philosophy.

SYSTEM DESCRIPTION

SYSTEM DESCRIPTION

This study resulted in a conceptual design essentially satisfying the requirements detailed in the preceding section. The design, shown diagrammatically in Figure 13, consists of a number of lengths of three-quarter-inch diameter cable coupled end-to-end with a pipe-like housing. This housing (Figure 10) provides for instrumentation in the central section. The end pieces contain the cable terminals and appropriate electrical fittings.

The cable is covered with a free-swiveling, hydrodynamic fairing (Figure 9) to reduce drag and vibration. The instrument modules are also faired.

A core-space of about one-half-inch diameter is available within the load-carrying cable armor to accommodate any suitable electrical cable.

The cable-fairing-module assembly is retained at proper depth by a depressor (Figure 3) which develops the requisite depressing force by a combination of weight and hydrodynamic reaction.

Shipboard handling can be accomplished by a tractor-type capstan (Figure 12) for systems with rigid instrument modules distributed along the faired cable, or a twin load-drum (Figure 11) for systems lacking modules.

1. The first part of the document is a list of names.

2. The second part of the document is a list of names.

3. The third part of the document is a list of names.

4. The fourth part of the document is a list of names.

5. The fifth part of the document is a list of names.

6. The sixth part of the document is a list of names.

7. The seventh part of the document is a list of names.

Shipboard storage can be accomplished by the use of six compact storage reels, each accommodating 1000 feet of cable (cable connectors at 1000-foot intervals permitting such breakdown) or by coiling the cable in 6000-foot-capacity stowage wells.

A system employing binary coding to permit sequential sampling of the sensing gages was designed only to demonstrate the feasibility of transmitting data from a large number of sensors with the selected wire size. This technique provides for sampling 128 sensors with only ten conductors. The number of sensors may be doubled by each additional wire.

The various components are described in greater detail in later sections.

SYSTEM DESIGN

SYSTEM DESIGN

SYSTEM CONSIDERATIONS

This study is concerned with means for providing continuous underway measurement of ocean variables at a number of points in a vertical profile. The design of a towed-instrument system, with a flexible towing member providing both data link and support, is presented.

The problem consisted essentially of finding a configuration to provide the required 5000-foot depth, utilizing a towing link of sufficient dimensions to accommodate the data-transmission function and also providing a reasonable margin of reserve strength at a specified towing speed without imposing unusual demands on handling gear.

The first step in the solution of this problem was the establishment of the relationship between the towing link and the forces required to maintain it in the desired configuration. The towing link was specified from the results of these studies, incorporating data-transmission requirements. A depressor was then designed, achieving the required force characteristics without unreasonable size and weight penalties.

Instrument containers, compatible with this towing link were then investigated and winching equipment selected.

As the interdependent requirements can be most conveniently discussed in conjunction with particular components, detailed considerations are presented in the appropriate following sections.

COMPONENT SELECTION AND DESIGN

Selection of Cable Type

Several types of towing member have been used in comparable applications. One such type is a segmented chain of rigid links with provision for one or more separate electrical conductors. Typical of such designs is the "thermistor chain," developed by the Commercial Engineering Company in conjunction with Woods Hole Oceanographic Institution (2), and successfully used in obtaining continuous measurements of the temperature profile. The largest such unit, in use by the Department of Oceanography and Meteorology at the Agricultural and Mechanical College of Texas, has a length of 900 feet. The significant disadvantage of this towed system lies in its size and weight. Since even the 900-foot unit is extremely bulky, this type of equipment would hardly be practicable for use to a depth of 5000 feet.

Another type of towing member is a stranded steel cable combined with one or more electrical conductors. In one design, a conventional wire rope center is employed as a strain member; the insulated electrical leads are wrapped around this core, and the whole is enclosed in insulation. An alternative design, known as armored cable, has the electrical member, either multi-conductor or co-axial, as the core with the steel wires wrapped around the outside in one or two layers.

The single-armor type is frequently employed as undersea transmission cable. The double-armor cable is used extensively in oil-drilling operations and in naval systems such as the variable-depth sonar. There is a significant advantage in using a cable with the electrical leads in the outer jacket as this simplifies the problem of connecting measuring instruments along the cable. This advantage is offset, however, by handling problems, as the electrical leads are susceptible to crushing and wear. In some applications, a wire rope and a separately attached electrical cable have been employed. Here, the handling problem is still serious, as the electrical leads may be crushed under the wire rope in passing over sheaves and drums; it is not practicable to prevent twisting of the two cables in handling. Furthermore, under tow, the electrical cable tends to billow out between points of attachment and thus to increase the drag and vibration of the system. This can cause early fatigue failure of the electrical leads, and breakdown of the insulation.

Another design employs the strength member as an electrical conductor. This principle is used in the cable used in the deep oceanographic instrumentation probes being developed by Scripps Institute of Oceanography. That cable, manufactured by Columbia-Geneva Steel, is a steel strand composed of 19 wires, 0.031-inch O.D., and 18 wires, 0.028-inch O.D., covered with a polyethylene jacket to 0.32-inch O.D. This cable has an

estimated breaking strength of 2800 pounds. FM telemetering with a seawater return is used to send a large number of signals over several miles of cable. This technique offers some definite advantages, particularly in simplifying the connector problem, although its use does require a complex electronic telemetering system both within the instrument package and at the shipboard recording station.

These possible designs were considered at length, and discussed with members of organizations engaged in oceanographic research. As a result, it was decided to select a double-armor cable, with either a co-axial or multi-conductor core, as the basic configuration for the system. This selection does not preclude the possibility of using a single-strand combined strength and electrical conductor, however, since the basic design can be readily adapted to such use.

Consideration was also given to the problem of adding fairing to the cable to reduce its drag and vibration. Although the use of fairing seriously complicates the problems of storage and handling, and adds significantly to the cost, the achievement of great depths at reasonable towing speeds without the use of fairing is impractical. Unfortunately, obtaining comparisons of configurations that might satisfy requirements for depth and speed involves laborious calculations, using methods as described in (3). The tediousness of this task motivated the development of the

simplified engineering design procedure presented in (1). Since the earlier report, (1), constitutes an integral part of this study program, the details of these calculations will not be repeated here.

If we refer to the analysis of (1), a comparison of the unfaired- and faired-cable system requirements necessary to achieve a 5000-foot depth can be made. In the faired-cable case, it is shown that, if the tension at the water surface is limited to one-third the breaking strength of the cable, the minimum value of $\frac{d}{V^2}$ required to reach a depth of 5000 feet is $42 \times 10^{-6} \frac{\text{sec}^2}{\text{ft}}$. Here, d is the diameter of the cable and V , the towing speed. Corresponding to this ratio, the value of $\frac{T_0}{d^2}$ is $1.14 \times 10^6 \frac{\text{lbs}}{\text{ft}^2}$. Here, T_0 is the required downforce on the bottom end. The required cable length, s_1 , is 6200 feet, and the horizontal distance from the bottom end of the cable to the tow point is 3500 feet.

In the unfaired-cable case, as a result of the choice of the hydrodynamic loading functions, the curves do not exhibit a minimum value for $\frac{d}{V^2}$. This may be seen in Figure 1, which presents a comparison of the requirements for the faired and unfaired cases.

In carrying out these calculations, the methods of (4) were employed. The tension in the cable at the water surface was assumed to be one-third the breaking strength of the

100-100000

100-100000

100-100000

100-100000

100-100000

100-100000

100-100000

100-100000

100-100000

100-100000

100-100000

100-100000

100-100000

100-100000

100-100000

100-100000

100-100000

100-100000

100-100000

100-100000

100-100000

100-100000

100-100000

$$\frac{T_0}{d^2} \cdot \frac{\text{Pounds}}{\text{Foot}^2}$$

0 1x10⁶ 2x10⁶ 3x10⁶

Conditions

Depth = 5000 Feet
 Tension at top = 1/3 Breaking Str.
 Drag Coeff. = $\begin{cases} 0.2 \text{ Failed} \\ 1.2 \text{ Unfailed} \end{cases}$ based on diameter

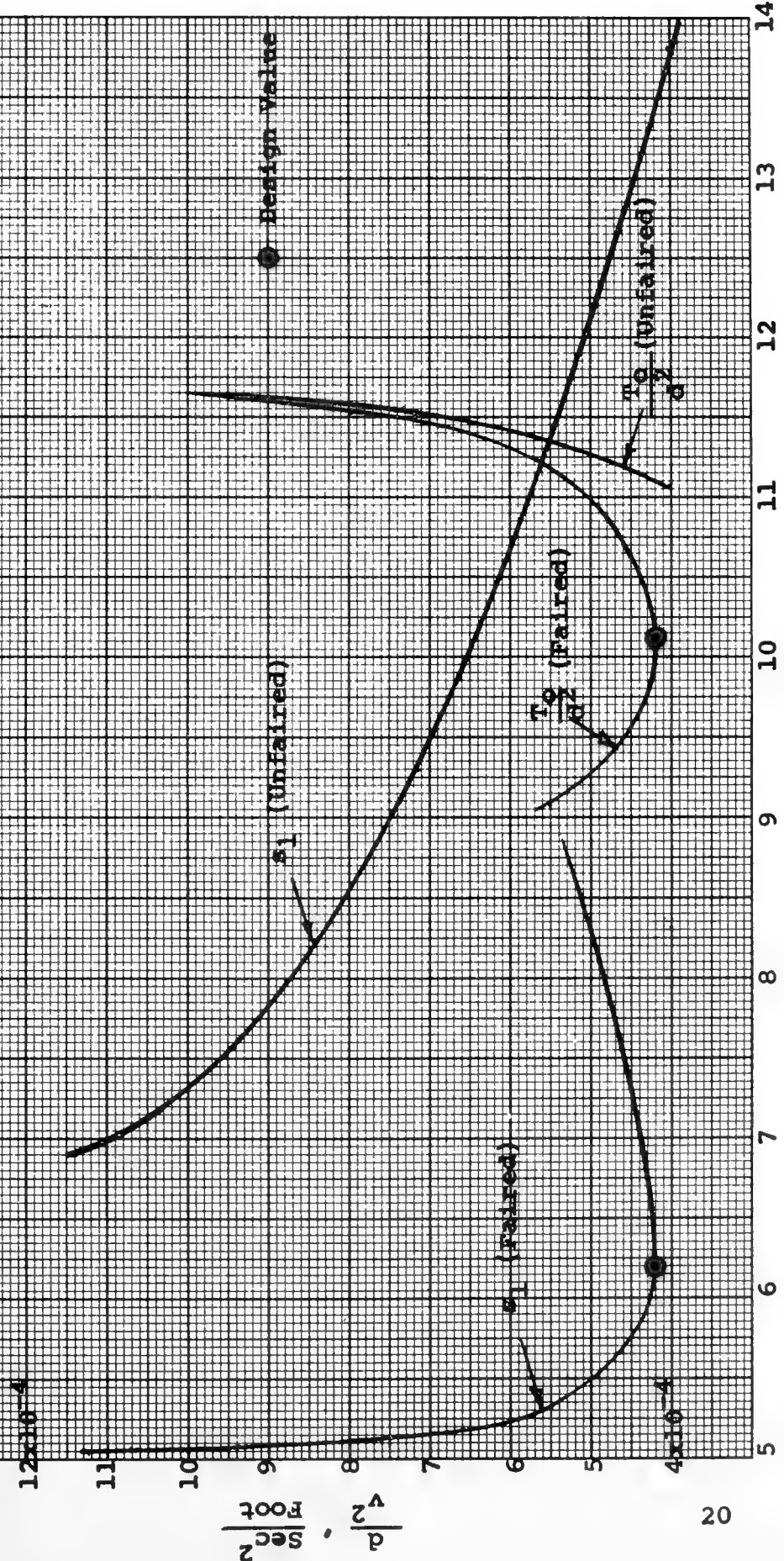

Cable Length, s_1 , in Thousands of Feet

Figure 1. Comparison of Requirements for Failed and Unfailed Cable to Reach a Depth of 5000 Feet.

double-armor cable. The fairing was assumed to be weightless in water. Other assumptions are noted in Figure 1.

Significant advantages in the use of faired cable for achieving the 5000-foot depth are apparent in Figure 1. From the minimum value, $42 \times 10^{-5} \text{ sec}^2/\text{ft}$ for $\frac{d}{v^2}$, the minimum allowable diameter of faired cable may be determined, once the highest desired towing speed is selected. The curves show that if unfaired cable of the same diameter were employed for the same requirements of depth and speed, more than twice the length of cable would have to be used. Moreover, the required downforce at the lower end would be about double that required for the faired cable. For these reasons, and because of the greater cable-life expectancy attributable to fairing, faired cable was selected for this design, in spite of the additional handling problems and increased costs.

Selection of Cable Size and Downforce

Since we have now chosen the basic configuration, and have determined that the minimum value $\frac{d}{v^2}$ is 42×10^{-5} sec²/ft for the 5000-foot depth, the selection of cable size becomes a matter of balancing requirements for a reasonable upper limit on the towing speed against the required size of electrical conductors and the practical problems of handling the system. Figure 1 shows the cable size and downforce required as a function of the maximum speed of tow, the downforce being obtained from the value $\frac{T_0}{d^2} = 1.14 \times 10^6 \frac{\text{lbs}}{\text{ft}^2}$, corresponding to the minimum value of $\frac{d}{v^2}$. Note that, at the maximum allowable speed corresponding to the cable size selected, the cable length and horizontal distance of the bottom end from the tow point remain the same: namely, 6200 feet and 3500 feet, respectively.

Upon examination of Figure 2, it becomes evident that the required cable size and downforce increase rapidly with increase in speed. This is due, of course, to the fact that the hydrodynamic forces acting on the system increase as the square of the speed. If we adopt the position that, in consideration of difficulty in handling and system costs, it is desirable to keep the cable size as small as possible, then the required size of electrical conductors becomes the

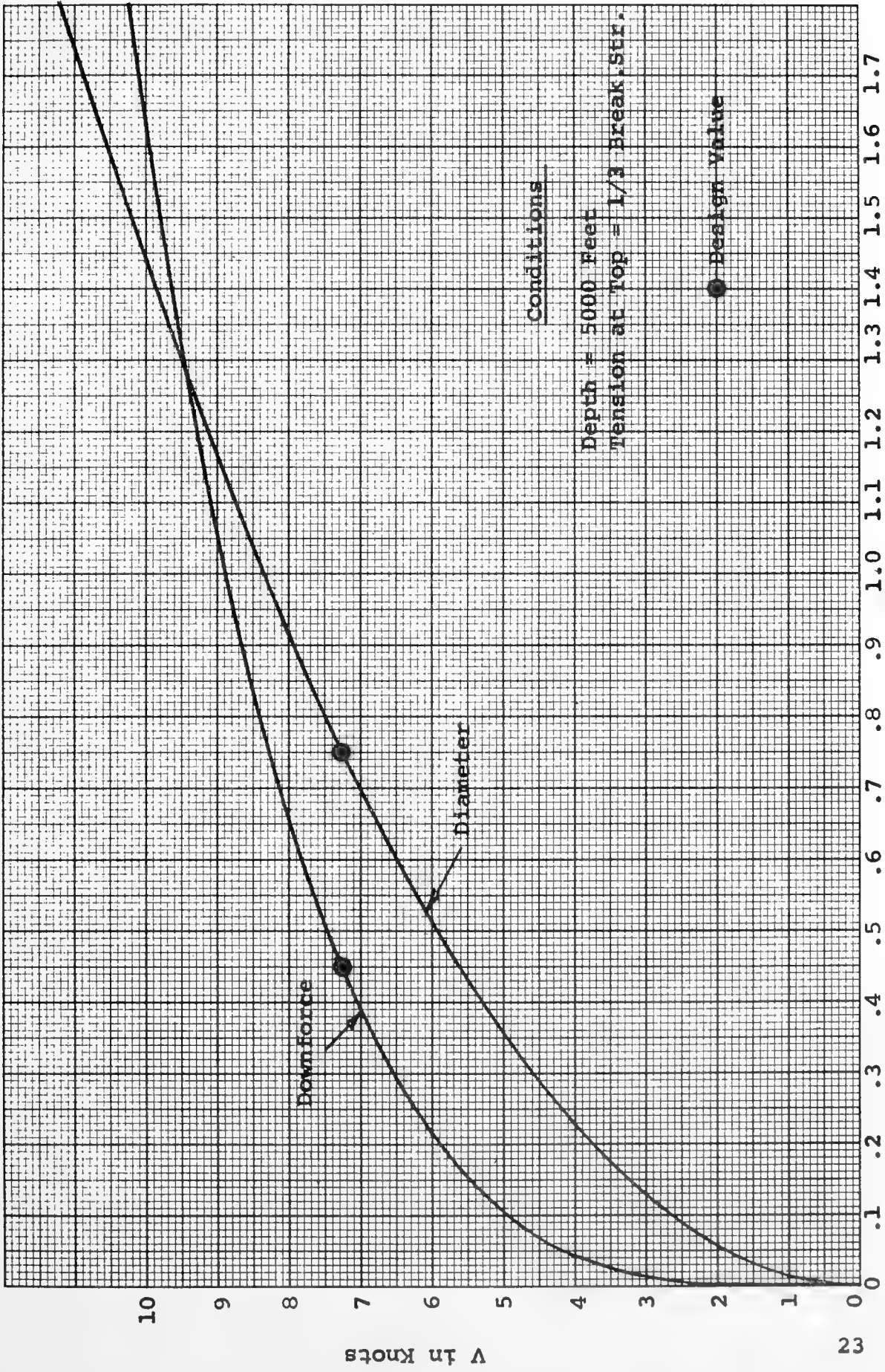

d in Inches
 T_0 in Tens of Thousands of Pounds

Figure 2. Effect of Towing Speed, V , on Required Downforce, T_0 , and Cable Diameter, d .

dominant design factor. The size of the conductor, depending as it does on the characteristics of the instrumentation, cannot be definitely established at this time. Rigid specifications of cable size must await delineation of specific applications on which instrumentation choice, and hence conductor size, depends. However, it appears likely that cable of at least one-half-inch diameter will be required for most applications. To allow for some flexibility in the instrumentation, cable of three-quarter-inch diameter was selected for this study. On this basis, maximum towing speed attainable without allowing the tension to exceed one-third the breaking strength of the cable, is about 7.2 knots. The downforce required at this speed is about 4450 pounds.

Design of the Towed Body

Two methods may be used to produce the downforce required on the bottom end of the cable. One is to attach a stable towed body, with weight in water equal to the required force; the other is to employ the hydrodynamic force produced by depressing wings attached to the body.

Disadvantages of using weight alone are:

1. The heavier the body the more difficult the problem of shipboard handling; and
2. With constant weight and a given cable length, depth of tow decreases with increase in speed.

Advantages of using weight alone are:

1. The towed body is less responsive to disturbances from the flow and from motion of the towing vessel;
2. Design of the towed body is less critical and less difficult;
3. The body is less subject to serious damage in handling; and
4. Accelerative forces during launching and retrieving while under way are less severe than transient hydrodynamic forces experienced with a winged body.

In applications where the required downforce is small (less than 1000 pounds) and the speed low, it is generally conceded that downforce can best be produced by the use of weight alone. There are exceptions to this: in a helicopter-towed system, weight becomes a critical factor. The configuration considered herein requires a downforce of 4450 pounds at a design speed of 7.2 knots. Users of oceanographic equipment were asked for comment on the shipboard-handling problem of such a heavy body and were unanimously of the opinion that the maximum practicable weight, for ease of handling aboard most oceanographic vessels, should not exceed 1000 pounds. They also concurred in citing a maximum acceptable linear dimension of seven feet.

In view of this unanimity of opinion, our configuration was designed to achieve the required downforce by a combination of weight and dynamic depression. An arbitrary weight of 1000 pounds in water was assumed, and calculations were made (see Appendix I) to determine the wing and tail configurations needed to produce the additional 3450 pounds of downforce at a towing speed of 7.2 knots. A biplane configuration was selected to keep the span small for easier handling. With the calculated necessary effective hydrodynamic lifting area of 39.75 square feet distributed equally, each wing, and the tail, has an area of about 13 square feet. The resulting configuration is shown in Figure 3.

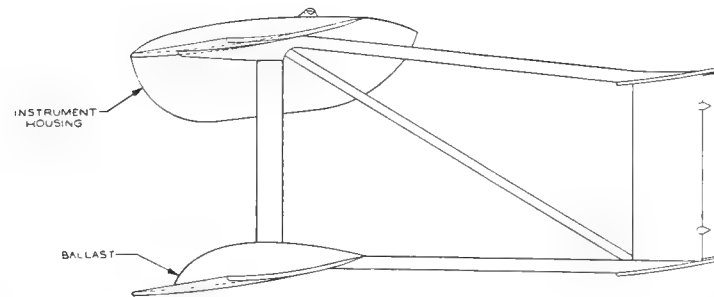
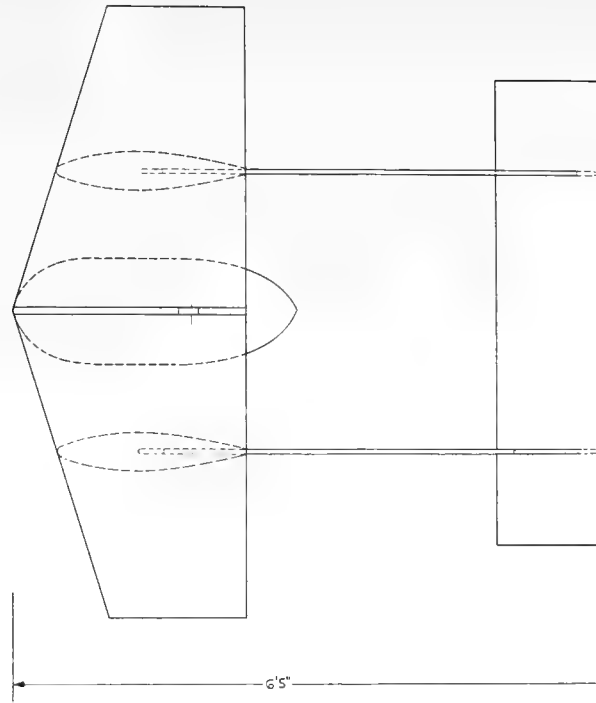
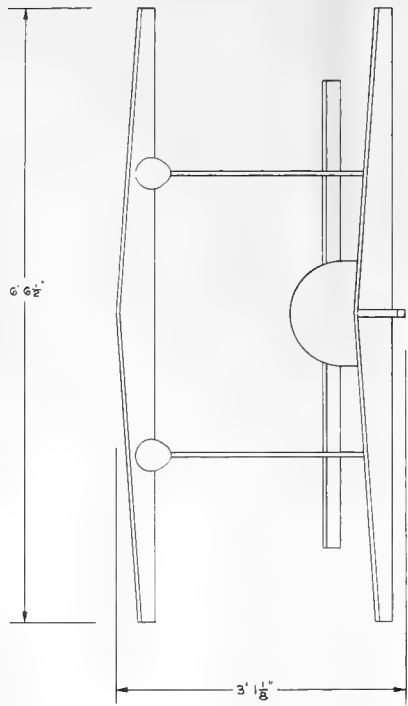

The wings are swept back to reduce the danger of fouling by seaweed and debris. Provision is made for an instrument capsule with a volume of about one cubic foot, to house equipment required at the maximum depth. The volume of the housing was selected arbitrarily and can be increased considerably without significant change in the system characteristics. Since the total weight of the body in water will be less than 1000 pounds, the additional static downforce required is provided by ballast weights. This provision facilitates static trim of the body and also increases the metacentric stability.

The stability of the body has been treated only for the static case. However, the margin of static stability, determined by past experience, should ensure satisfactory dynamic stability. This and other towing characteristics of the body can best be verified by limited tests in a towing basin. Such tests are usually desirable in any event in order to make final adjustments to ballast, location of tow point, and settings of wings and control surfaces.

The effect of variation in speed on downforce and drag was calculated. Results, presented in Figure 4, show that the cable angle at the body is about 84 degrees at the design speed, this angle being $\arctan \frac{L_0}{D}$, where L_0 is the total downforce and D the total drag. With decrease in speed, the angle increases to a maximum of 90 degrees, since the weight is a constant and the hydrodynamic forces vary

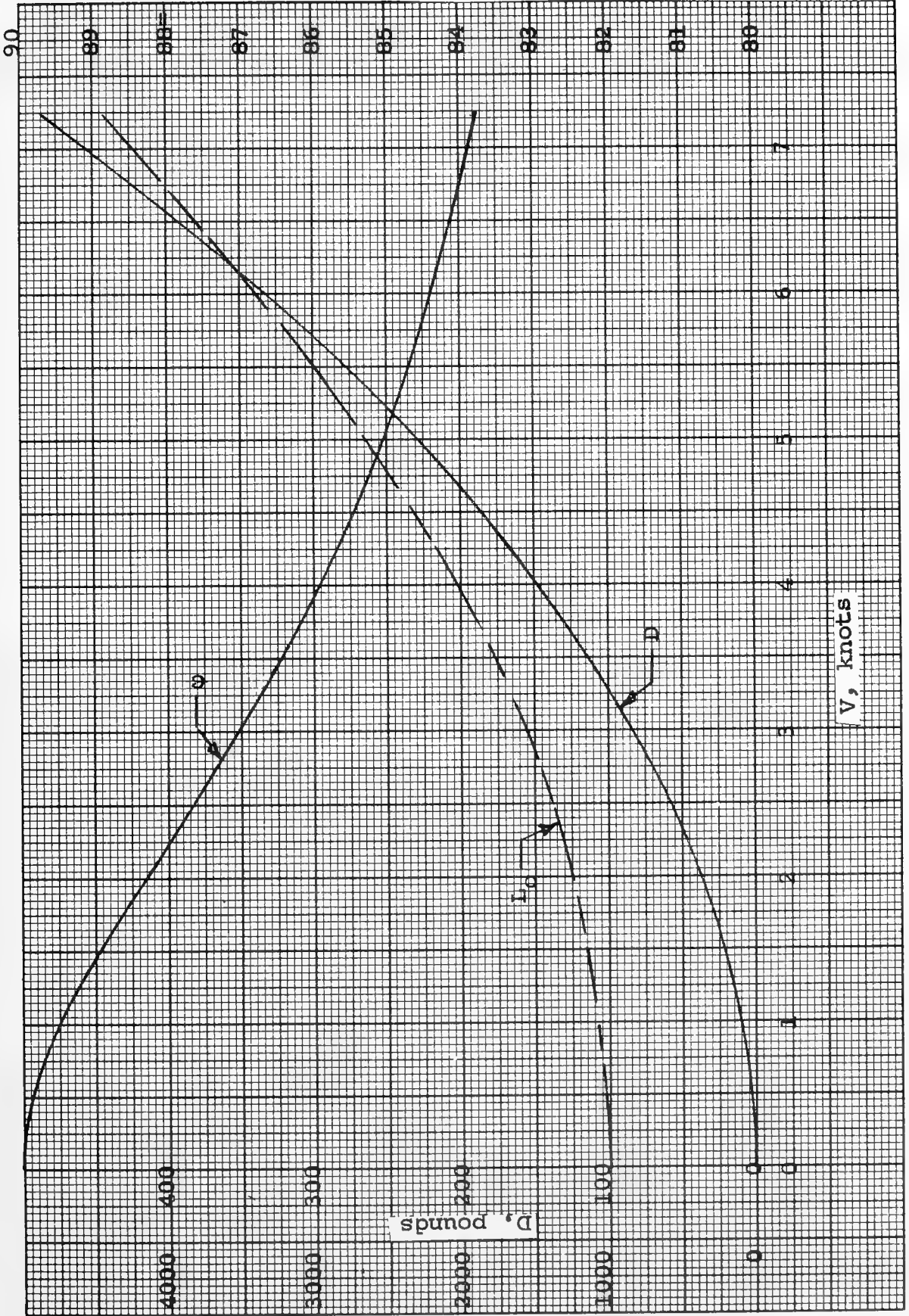

Figure 4 - Computed Variation of Downforce, L_0 , Drag, D, and Downforce to Drag Ratio, $\phi = \arctan L_0/D$, as a Function of Towing Velocity

approximately as the square of the speed. This result is consistent with the assumption made in (1), that the cable angle is not significantly less than 90 degrees.

Effect of Variation in Speed and Cable Length

The basic design configuration of the cable-body system having been determined, it is of interest to determine the effects of changes in the speed and length of cable payed out. Using the results of Figure 4, and the tabulated functions in (4), calculations of these effects were made and results presented in Figures 5, 6, 7, and 8. Figure 5 shows that, as the speed is reduced from 7.2 knots to zero, additional cable can be payed out to achieve a maximum depth of about 17,000 feet without exceeding a static tension of one-third the breaking strength of the cable. For the chosen three-fourths-inch double-armor cable, this limiting tension is approximately 15,000 pounds. Figures 6, 7, and 8 show the effect of speed variation on the tension at the top, T_1 , the depth, y , and the horizontal displacement of the body, x , for fixed cable lengths of 1000, 3000, and 6000 feet. The figure for maximum attainable depth shows a small discrepancy between this computation and (1). This discrepancy derives from the assumption made in (1) that the cable angle at the bottom is 90 degrees. The curves in Figures 5, 6, 7, and 8, based on the calculated values of cable angle shown in Figure 4, represent a refinement of the original design approximation.

Further examination of Figures 6 and 7 shows that the full speed capability has not been utilized since the tensions

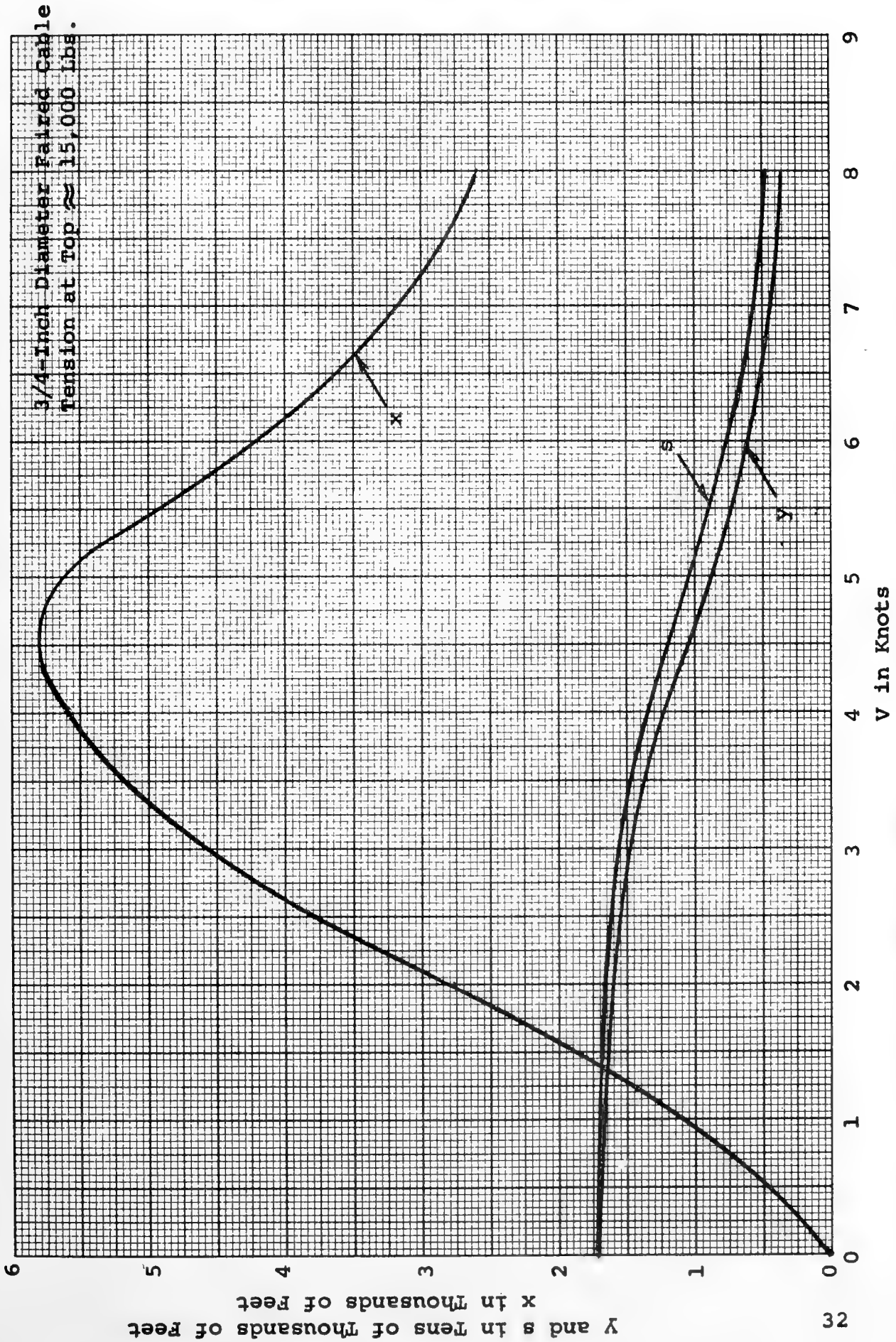

Figure 5. Effect of Towing Speed, V , on Depth, y , Cable Length, s , and Horizontal Displacement of Towed Body, x , for a Constant Tension at Top

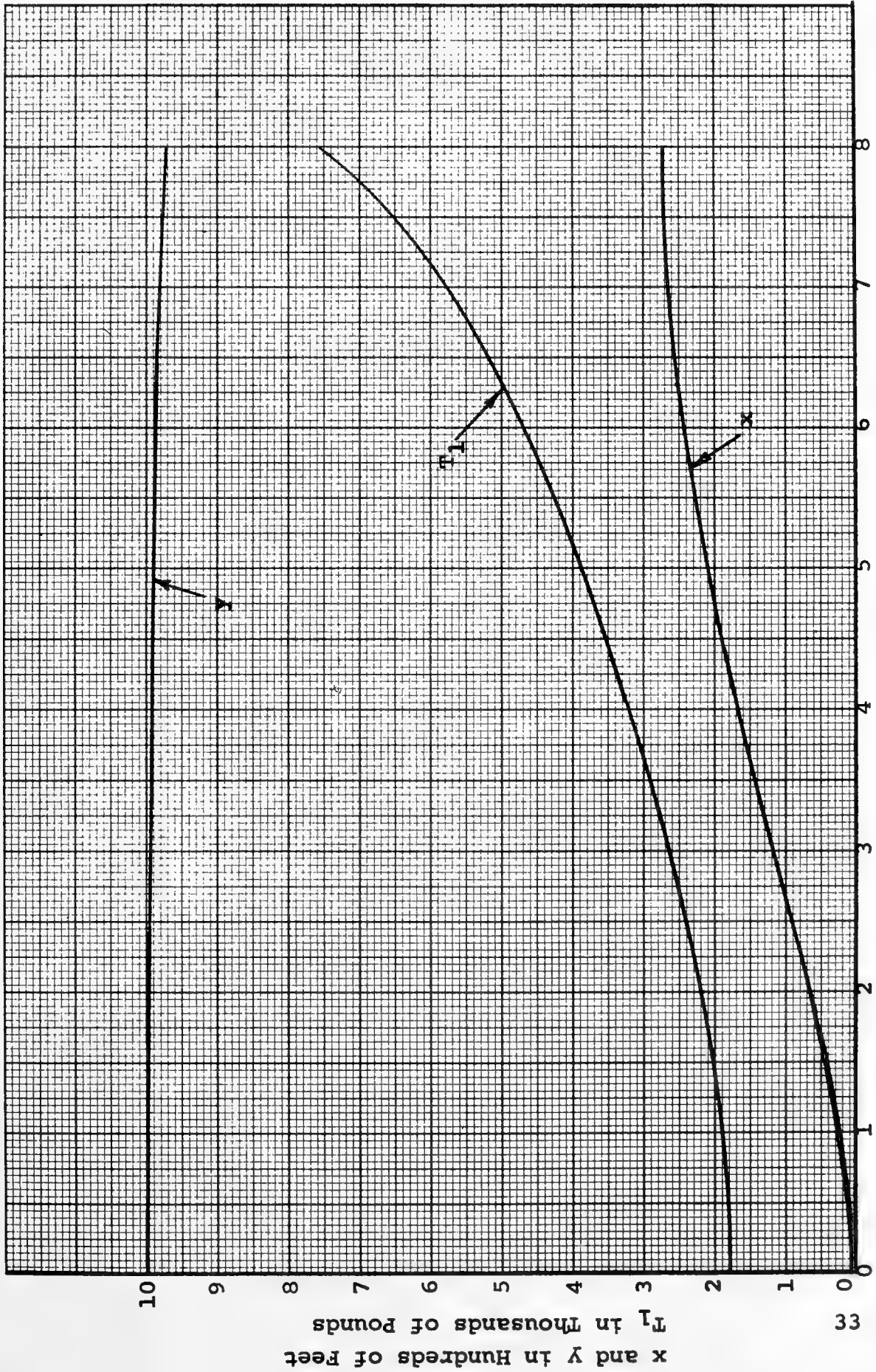

Figure 6. Effect of Towing Speed, V , on Depth, y , Tension at Top, T_1 , and Horizontal Displacement of Towed Body, x , for a Cable Length of 1000 Feet.

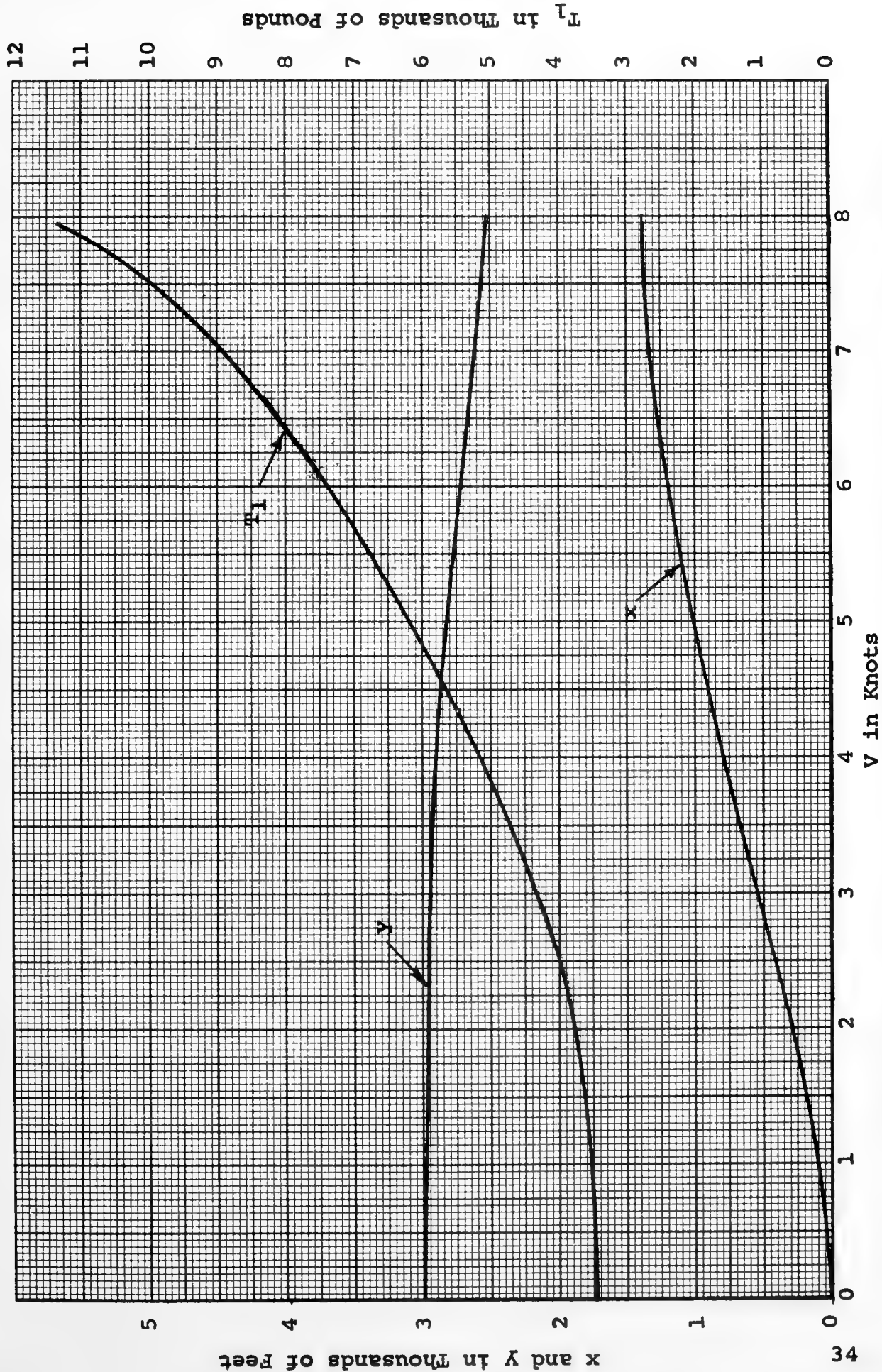

Figure 7. Effect of Towing Speed, V, on Depth, Y, Tension at Top, T₁, and Horizontal Displacement of Towed Body, x, for a Cable Length of 3000 Feet.

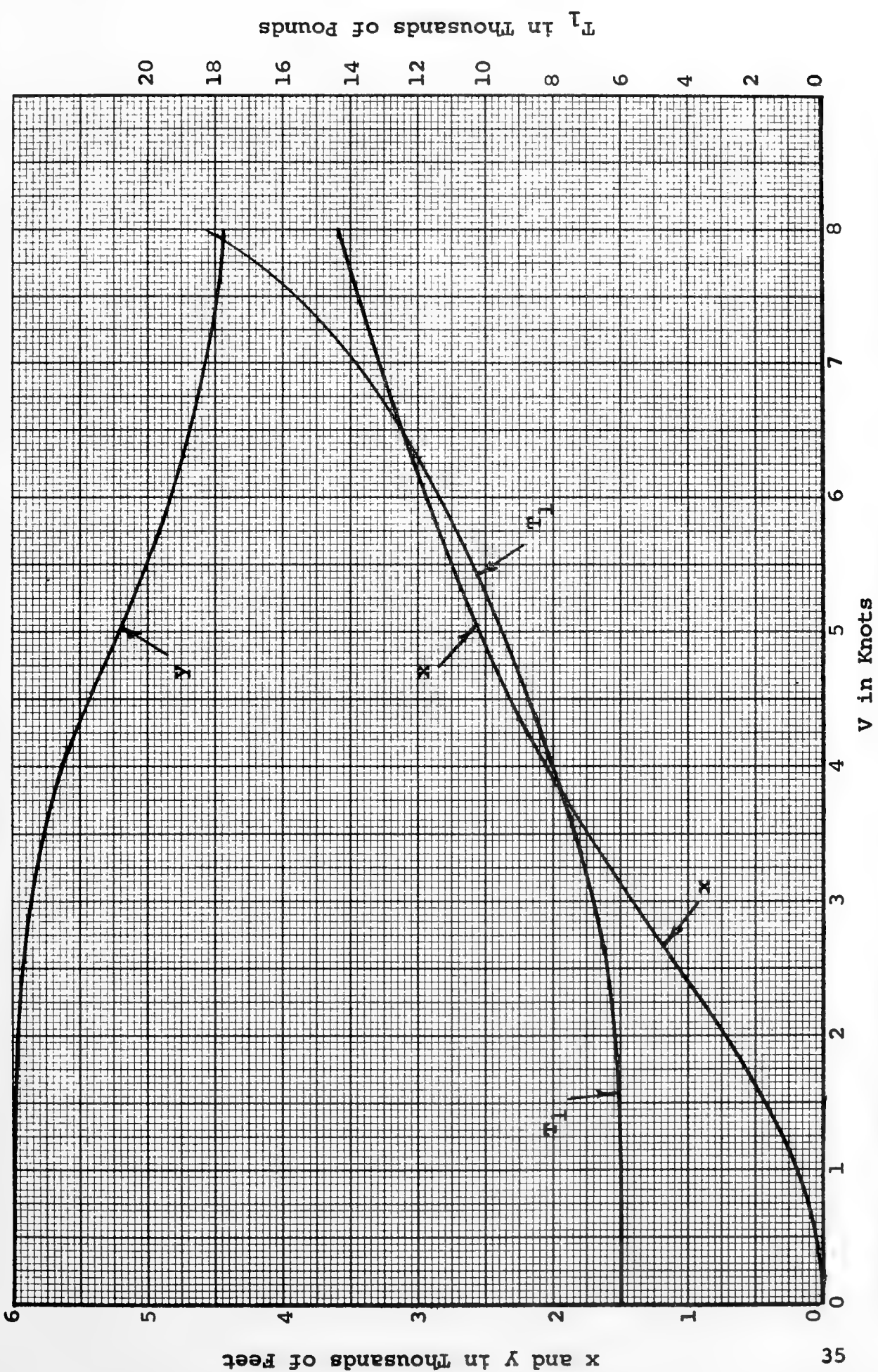

Figure 8. Effect of Towing Speed, V , on Depth, y , Tension at Top, T_1 , and Horizontal Displacement of Towed Body, x , for a Cable Length of 6000 Feet.

at 8 knots are below the imposed limiting value. The tensions vary nearly as the square of the towing speed in this speed range; we may estimate the maximum towing speed for a cable length of 1000 feet to be 11 knots and for a cable length of 3000 feet, 9 knots.

Cable Fairing

Considerable effort has been expended, during the past ten years, on the development of a satisfactory design for cable fairing. The most outstanding development of this period was the David Taylor Model Basin enclosed fairing design (DTMB No. 7). This fairing, of molded rubber in a streamline cross section, completely encloses the cable. The fairing was used in continuous lengths for such applications as the air-towed and ship-towed sonar. Success was tempered by serious problems in handling and storing, as fairing of the enclosed design did not lend itself to running over drums and sheaves under load. Canadian researchers partially solved the handling problem when they modified the DTMB design and clipped the fairing to the cable. Certain improvements in this modification were introduced at DTMB as a result of model studies. It was found that the fineness ratio (the ratio of the chord length of cable-plus-fairing to the cable diameter) could be reduced to 4:1. It was also found that the ideal fairing thickness was about eight-tenths the diameter of the cable. A clip-type fairing for a three-quarter-inch cable designed according to these specifications, is shown in Figure 9.

The tendency of fairing to stretch more than cable under load constitutes a serious design problem. Even with fiber reinforcing strands molded into the leading edge, long sections of fairing tend to stretch along the cable and bunch up at

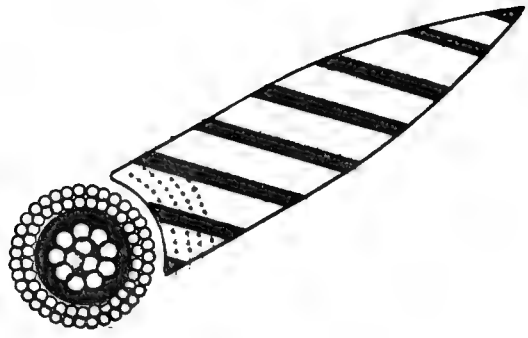
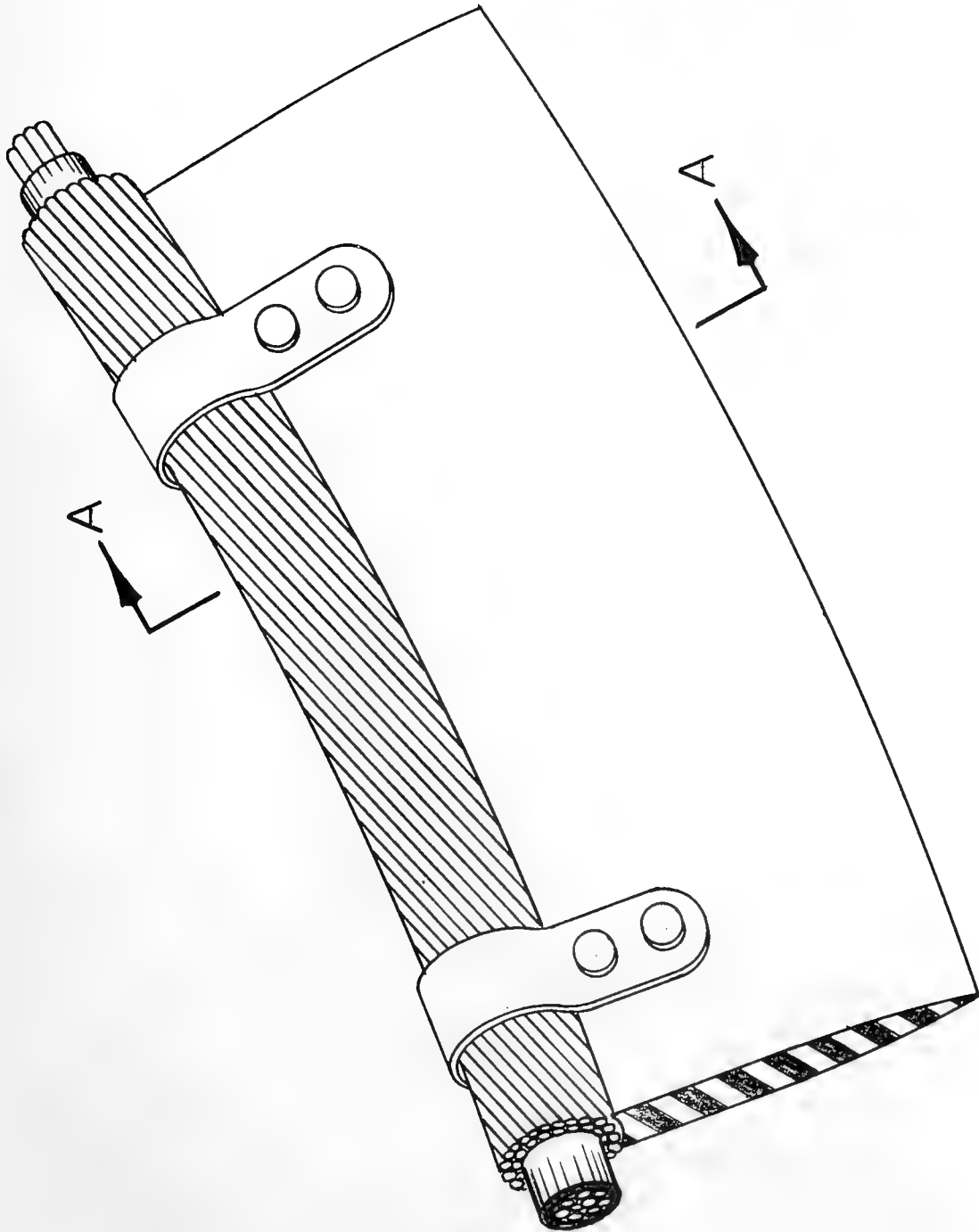

SECTION A-A

Figure 9 - Double-Armor Cable with Clip-Type Fairing

the lower end. Attempts to use swaged rings on the cable to support the clips have thus far been unsuccessful because the rings become loosened when the cable elongates under load. Recently, studies have been initiated to develop better methods of securing supporting rings on the cable but this problem is not yet solved. The problem of fairing stretching is minimized in our present design because each section of fairing will be less than 200 feet long. Each section would be supported at the upper end by a swivel attached to the lower end connector of each instrument module. The problem of bunching can be easily avoided if provision is made for slight stretch of the fairing sections at the bottom ends.

In specifying the use of cable fairing it is important to consider the manufacturing cost. Most fairing is made of natural rubber which is hand-layed to approximate size and then cured in a heated mold. This process is expensive, and even fairing of small section costs as much as five or six dollars per foot. Although studies of alternate materials, and possible development of an extrusion technique, have been initiated, no material has yet been found to possess as many desirable features as a rubber compound. Furthermore, extruded plastic fairings are subject to non-uniform stresses which cause asymmetries in shape and consequent erratic towing characteristics.

The most feasible means of cost reduction seem to lie in improved methods of rubber-fairing production. The Navy has recently contracted with the Marsh and Marine Manufacturing Company of Houston, Texas for the development of a new manufacturing technique and the production of sample fairing lengths. This development has been discussed with representatives of Marsh and Marine; they expect their studies to lead to production of clip-type fairing at considerably reduced cost.

Design of the Instrument Housings

The instrument housings for attachment at points along the faired double-armor cable must fulfill a number of requirements. They must:

1. Be watertight;
2. Be designed to house sensors of a variety of sizes and shapes;
3. Provide for necessary electronic equipment for transmission;
4. Provide watertight electrical connectors;
5. Be compatible with the shipboard handling system;
6. Provide for free-swiveling attachment of the sections of cable fairing;
7. Be of modular design, easily and rapidly connected to or removed from the cable;
8. Be of materials compatible with the steel cable in sea water and resistant to chemical corrosion.

It is vital that none of these stipulations adversely affect the towing characteristics of the system.

In order to fulfill these requirements, and recognizing the impracticability of controlling twist in the cable under load, it was decided to design an instrument housing circular in cross-section concentric with the cable.

In the absence of definite instrumentation details, the size of the housing was fixed arbitrarily. A cylinder with a minimum inside diameter of three inches, and a usable inside length of 12 inches, to provide space for housing a thermistor bridge and associated telemetry equipment, was selected for the preliminary design. Specifications were prepared, and an assembly, shown in Figure 10, was procured from the Marsh and Marine Manufacturing Company to demonstrate the feasibility of the design.

In this design, a mechanical clamping arrangement is used to secure the armor wires, but the quality of performance of this method has not yet been proven. Some difficulty can be expected, since the inner and outer armor wires are not of the same diameter. An alternate design, which shows considerable promise, consists of a poured fitting with epoxy as the potting material. The David Taylor Model Basin has been experimenting with a fitting of this type for some time and have found it to be completely satisfactory. If it can be established that a poured epoxy fitting will stand up for long periods, then it would appear to be the best solution to the armor-wire connector problem.

CABLE END TERMINATION

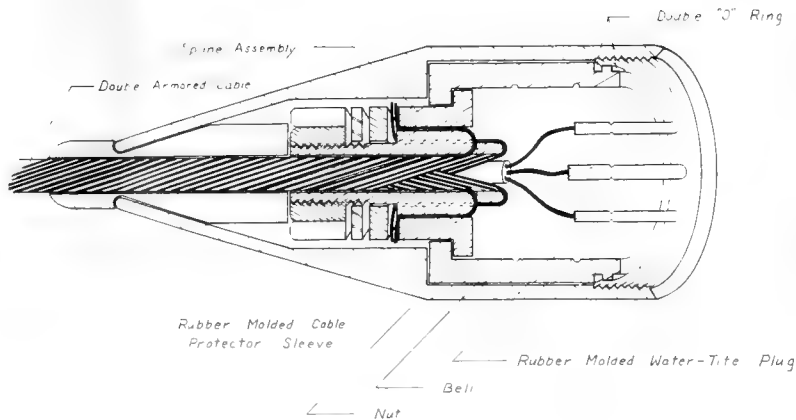

INSTRUMENT MODULE

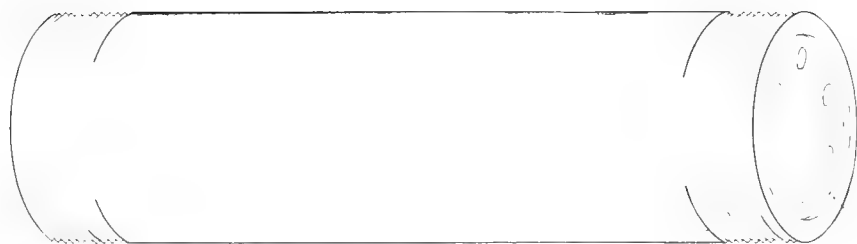

Removable Female Receptacle Assembly

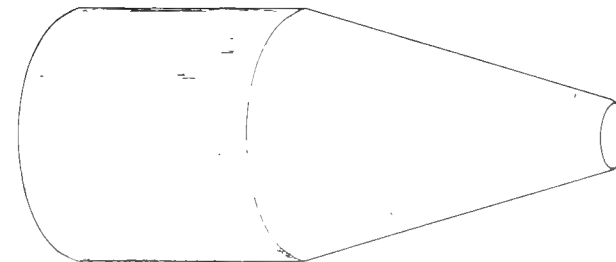

NOTES

- ① See Drawg "N-3482 for details of SPLINE ASSEMBLY and INSTRUMENT CASE
- ② See Drawg "N-3493 for details of BELL, NUT, SPLINE NUT and WASHERS, FEMALE RECEPTACLE and RUBBER MOLDED MALE PLUG

DRWG "N-3491

ARMORED CABLE SECTIONALIZING ASSEMBLY	
DESIGNED FOR	PneumoDynamics
DATE	2/3/61
DESIGNED BY	Bethesda A. Mariani
DRAWN BY	REL. SED
MARSH & MARINE	
523 G. Jefferson Dr.	Houston 30, Texas

Shipboard Handling Equipment

Probably the most important consideration in the use of any faired-cable system is the design of handling equipment for reeling in, paying out, and storing hundreds of feet of cable. The design of such equipment is even more critical in the system under consideration, since a number of instrument modules attached to the cable must also be handled.

It appears certain that, in handling long lengths of faired cable, it will be necessary to use a traction system which is separate from the cable-storing system. There are two ways in which this might be accomplished; one is to use twin load-drums and the other, to press the cable between tractor-like treads coupled to a drive motor. Either may be used in conjunction with one or more storage reels or with a cable well.

In the twin load-drum system, the cable is wrapped around two conventional drums as though they were a single unit. Projections of the drum axes are parallel in the plane of the deck and intersect at a small angle in a plane perpendicular to the deck. This angle determines the axial displacement of the cable as it passes from one drum to the other and this "canting" of the axes prevents "walking" of the cable along the drums. The diameter of the drums is determined, as in

conventional designs, by the minimum bending diameter of the cable. The length of the drums, however, need only be enough to accommodate the number of wraps required to absorb the tension in friction. Figure 11 shows a typical design using this principle.

The difficulty in using the twin-drum system (or any other drum system for that matter), lies in the necessity of passing the instrument modules under tension over the drums. The modules may be expected to be of large diameter in comparison with the cable, and of a length not significantly smaller than the drum radius. As a result, the concentrated loading on the module and the sharp bend in the cable at the connector may exceed strength limitations. The magnitude of this problem cannot, of course, be properly assessed until specifications are developed for a particular system. Nevertheless, it is likely that a drum system will not be acceptable for many such applications unless the drums are made considerably larger than would normally be required. For the system proposed here, tests with a small model twin-drum system are in progress, but results were not available in time to be included in this report.

Although the basic idea of a tractor-type capstan system has long been used in handling metal tubing and cable during the manufacturing process, the idea has only recently been applied to shipboard cable-handling problems. The principal

— DIESEL ENGINE

BI-AXIAL DRUM ASSEMBLY

CABLE STORAGE CONTROL ASSEMBLY

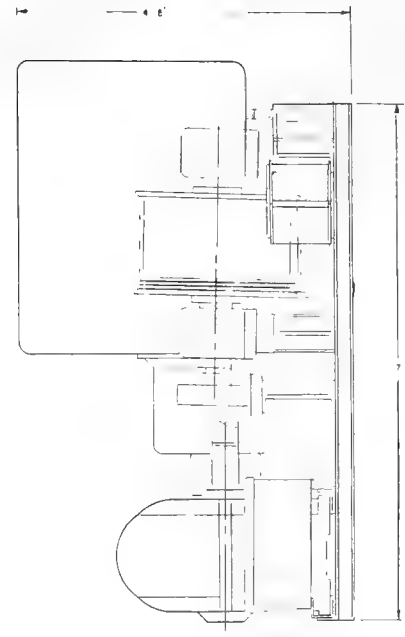
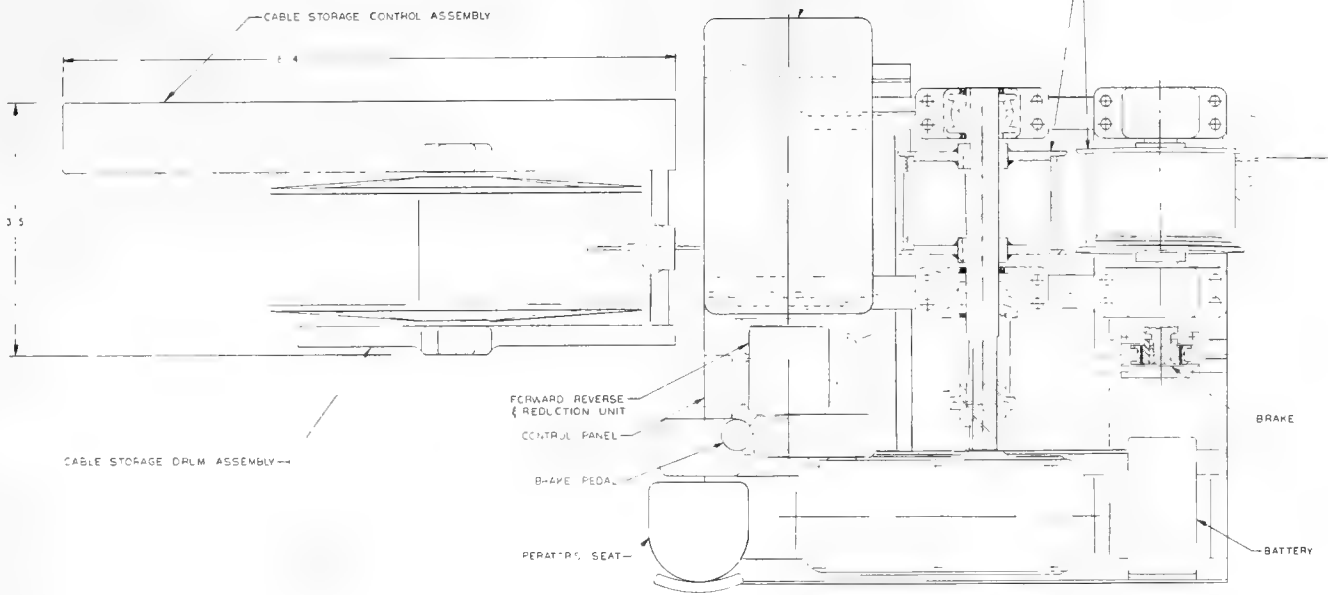

FORWARD REVERSE
REDUCTION UNIT
CONTROL PANEL

BRAKE PEDAL

OPERATOR'S SEAT

BRAKE

BATTERY

— SPEED REDUCER

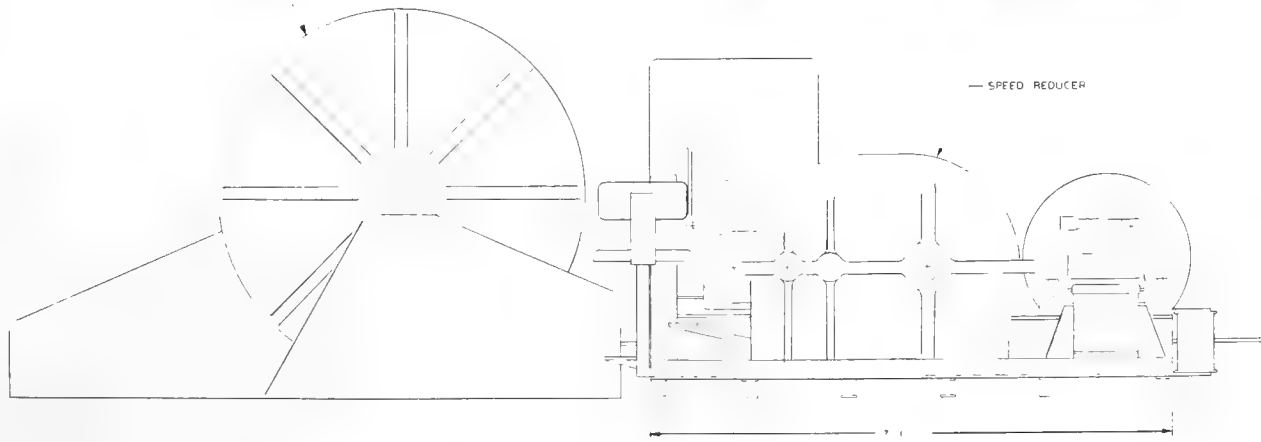

1 DIMENSIONS SUBJECT TO CHANGE
NOTES

LENGTH	FIGURE 11 TWIN LOAD DRUM	REV. NO. ENGINEERING NO. DRAWING CORPORATION
WIDTH		
HEIGHT		
SCALE		

proponent of this system is the Entwhistle Manufacturing Corporation of Providence, Rhode Island. This Company manufactures a number of different types of tractor-type capstans under the trade name "Caterpuller." The Navy some months ago purchased one unit (similar to that shown in Figure 12) and installed it on the destroyer USS GLENNON. Tests of this unit have been made by Destroyer Development Division, Group II at Newport, Rhode Island in connection with the installation of a deep-moored buoy system. It is reported that the unit on the GLENNON has successfully handled one-quarter-inch wire rope. Shackles and fittings up to two inches in diameter have been passed through the treads with no apparent difficulty and with no change required in the setting of the machine.

The use of a "Caterpuller" for the application proposed herein has been discussed with representatives of Entwhistle. The incorporation of a fail-safe system was emphasized, insuring that, if a failure in the equipment should occur, there would be no possibility for release of traction thereby allowing the cable to run free. Entwhistle representatives are of the opinion that a "Caterpuller" can be designed satisfying all system requirements and incorporating a fail-safe system insuring that any failure will cause sufficient pressure to be applied to the treads to restrain the cable under a load equal to the breaking strength. They

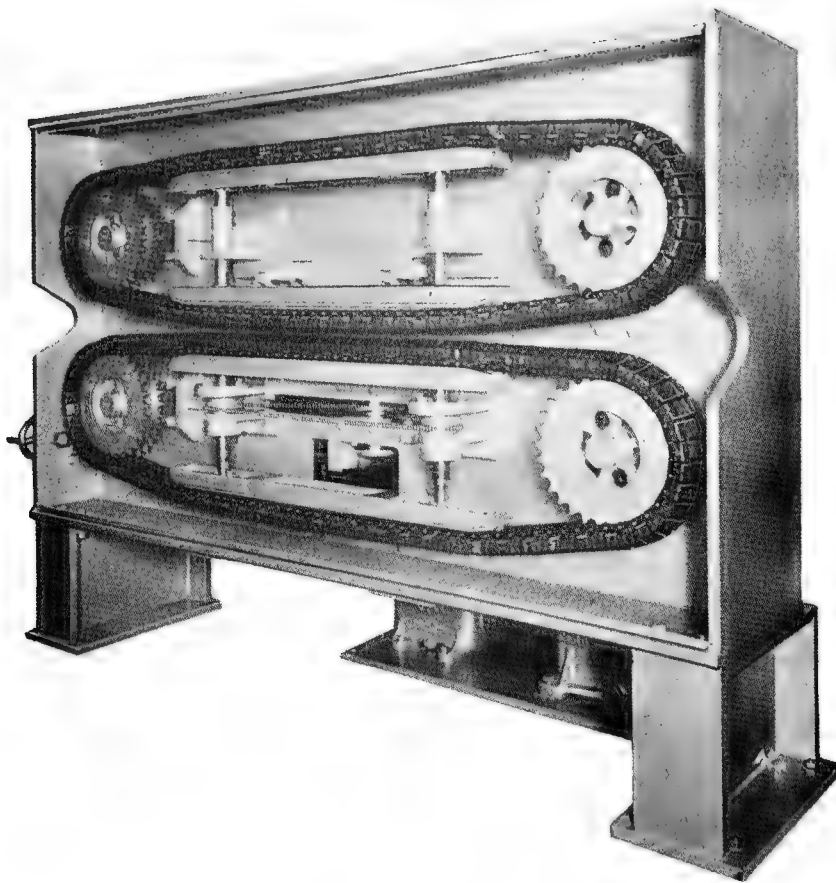

CLASS D
TYPE D-VA-72
CATERPULLER

Track Design: Floating.
Track Arrangement: Vertical.
Loading: Single Track - Multiple Pneumatic.
Effective Track Length: 45 Inches.
Maximum Recommended Operating Speed: 650 FPM.
Maximum Pull: 4000 Lbs. at 90 FPM.
Maximum Horsepower Input: 15 HP.
Cable Capacity: 3/16 to 6 inches in diameter.
Total Weight: 4500 Lbs. with drive.
Required Floor Space: 110 inches long, 64 inches wide.
Drive: Powered and Controlled to suit application.
Application: Cable Extrusion Lines.

Courtesy Entwhistle
Manufacturing Company,
Providence, R. I.

also feel that the instrument modules can be passed through the treads without damage either to modules or to tread faces.

As for the size of "Caterpuller" required for this application, (5) reports that a track loading of 500 pounds per inch is a reasonable design value. With such a loading "tractive pulls of from 100 to 300 pounds per inch of effective track have been achieved." Thus, to provide a maximum pull of 10,000 pounds, an effective track length of 33 to 100 inches would be required.

Figure 8 shows that at one or two knots, the tension in the cable, attributable chiefly to the combined weight of the body and cable is only about 6000 pounds. If the traction unit is designed to inhaul only at low towing speeds, the power required would not be large. Since inhaul and payout at frequent intervals should not be necessary, it would seem unreasonable to design for inhaul at the highest towing speed. Even if the inhaul load is not high, however, there is still a question regarding the normal loading that can be applied to the cable by the tread faces. This question arises as a result of the fairing. Even though the fairing is of rubber and of a thickness equal to eight-tenths the cable diameter, prevention of slippage of the cable relative to the fairing has not been demonstrated. The friction coefficient for the armored cable in contact with the tread faces

could conceivably vary between 0.05 and 0.3 depending on the presence of water or some form of preservative on the cable. This will be a factor in determining cable slippage. A further problem could arise in connection with the clip design. If the clips are made of spring steel to prevent permanent deformation by traction-unit pressure, they may be hard enough to damage the cable. A possible alternative is the use of some type of plastic clip, but this requires further study before actual selection of a clip design can be made.

The "Caterpuller" appears to offer the best solution to the design of an acceptable traction unit for the application discussed in this report. There are, however, many questions to be resolved before such a system can be considered acceptable. These questions can be resolved only by experiments with an existing "Caterpuller" unit in handling faired cable under tension.

Coping with the tension in the cable constitutes only part of the over-all handling problem; the other part involves storage of the cable on the low-tension side. One method is to store the cable on one or more reels which might be either separately driven or coupled to the load system to provide a small amount of back tension. Approximately 1000 feet of three-quarter-inch faired cable could be stored on a single, thin reel eight feet in diameter, with a two-foot diameter core. By using six such reels, and breaking the

cable with a connector at 1000-foot intervals, the entire 6000 feet of cable could be stored. An alternate method would be to store the entire 6000 feet of faired cable on a single reel six to eight feet in diameter and three to four feet wide. This would, however, require a level-wind device to provide for uniform spooling on the storage reel.

The use of one or more storage reels provides advantages in transporting the cable to and from the ship and in eliminating any need for manual handling during stowage operations. There is at least one disadvantage, however, in that the stored instrument modules are not readily accessible for inspection, servicing, or replacement.

Another method feeds the cable from the traction unit to a tank or cable well where it would be stored in a figure-eight to eliminate any kinking tendency. Considerable manual labor is involved in this method, but simplicity and easier access to the instrument modules are advantages. When this method was first proposed, the main objection concerned the safety hazard in the event of a failure in the traction unit. As noted previously, however, it is necessary to provide a fail-safe traction unit regardless of the selected storage system.

Since the proposed system will be comprised of short lengths of faired cable coupled by the module connectors, it

has been suggested that each length be de-coupled and stored along the deck during cable inhaul. Inasmuch as provision is to be made for quick disconnection of the modules, this appears at first glance to be an attractive solution. Upon further reflection, however, it can be anticipated that serious problems would arise from fouling of the electrical connectors by dirt and moisture. Once the array is assembled and checked out it should be de-coupled only when absolutely necessary to alter spacing, to change instrumentation, or to repair faulty elements.

INSTRUMENTATION

Although it was not the intent of this study to analyze requirements for instrumentation and data transmission, it was impossible to omit such considerations completely. Studies related to typical instrumentation housing and information transmission led to the design of a system for monitoring the temperature and pressure at many points along the cable. Some of the critical circuit elements were "breadboarded" to check the design. A detailed description of the instrument circuitry is given in Appendix III. In this system, binary coding is employed to make possible the sequential sampling of 128 sensing gages by the use of only seven wires for gage selection, one wire for gage output, one wire for calibration, and one wire for power. The ground return is provided either by an additional wire or by the steel jacket and the seawater. The number of sensing gages may be doubled for each additional gage-selection wire. A feature of the system is that failure in one of the instrument packages will not affect the operation of the rest of the system.

Although this instrument system offers distinct advantages over a co-axial FM telemetering system, there is no reason why a system employing coaxial cable could not be designed. The only requirement to be met is that the electrical conductor must be small enough to occupy the

core of the double-armor cable. Since the core diameter of a three-quarter-inch cable is approximately one-half inch, there would be ample room for either type of telemetering system. Admittedly, either system involves the use of complex electronic circuitry but, even with relatively wide spacing of the sensors, it does not appear possible to avoid the use of a somewhat sophisticated electronic system. This should not, however, be cause for great concern since far more complex telemetry systems are currently in wide use and improvements in reliability at decreased cost are being made continually. The development or selection of a satisfactory telemetering method, therefore, should not be a significant obstacle in the development of the proposed measuring system.

DISCUSSION

DISCUSSION

This study was conducted to provide a design for a cable-towed system capable of making simultaneous measurements at a great many depths in a vertical profile down to 5000 feet, with continuous monitoring of the instrumentation. The result is a generalized design (shown diagrammatically in Figure 13), satisfying the basic requirements of such a system.

The most promising means for achieving such depths at reasonable towing speeds is the use of double-armor cable with clip-type fairing. The fairing must be limited to relatively short lengths, probably no greater than one or two hundred feet, and the upper end of each fairing length must be tied back into the cable by means of a swivel support. The required downforce on the bottom end of the cable may be obtained by a combination of weight, and hydrodynamic force produced by depressing wings. To facilitate handling, the body weight should not exceed 1000 pounds.

A depth of 5000 feet can be attained with only 6200 feet of cable at a towing speed of 7 knots, using three-quarter-inch-diameter double-armor faired cable, without exceeding one-third the breaking strength (approximately 15,000 pounds).

The "Caterpuller" offers the most promise in shipboard handling of systems containing rigid instrument modules distributed along the faired cable. A twin load-drum should be satisfactory for systems not containing such modules.

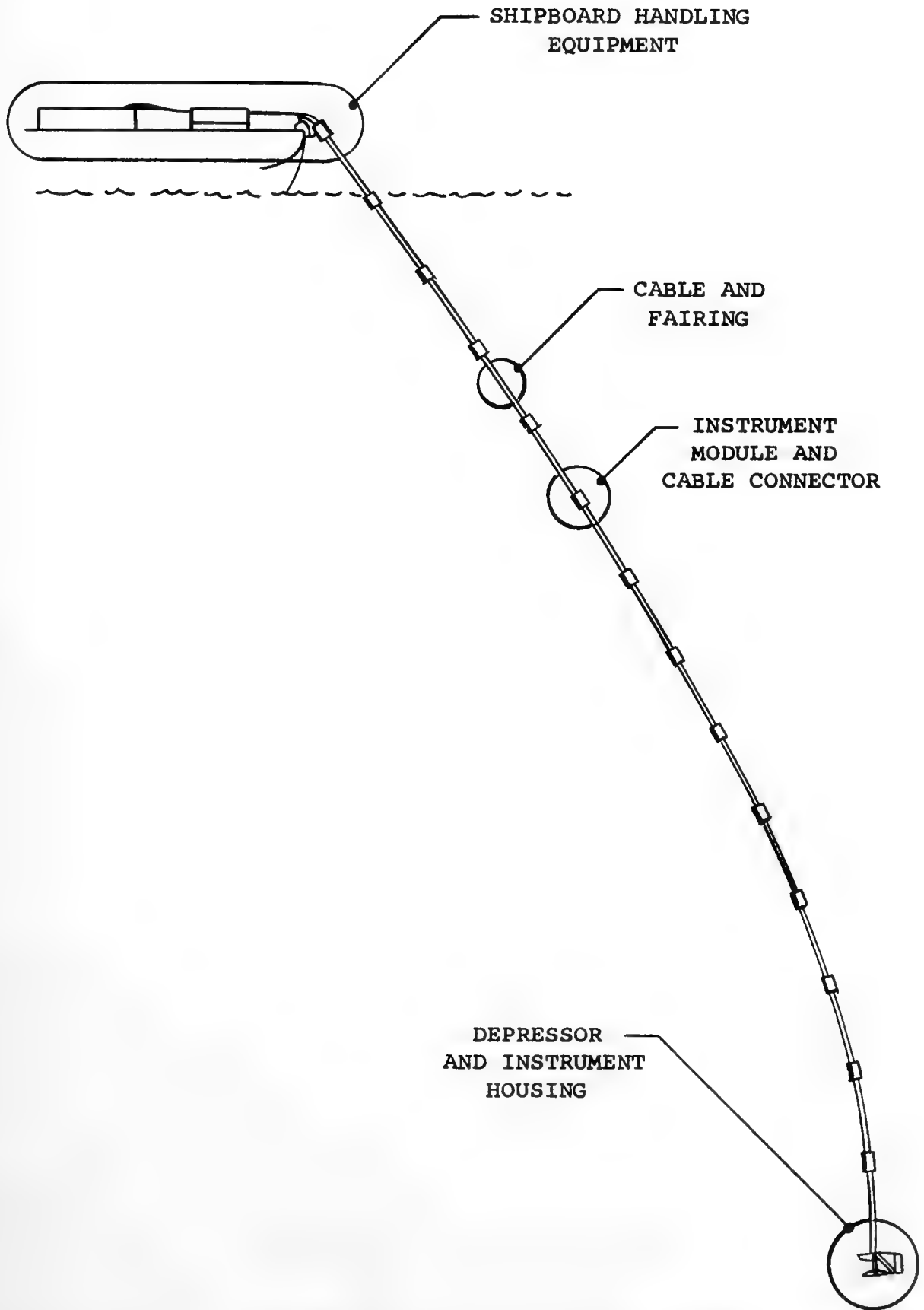

Figure 13 - Generalized Design of a Cable-Towed Instrumentation System

Several questions remain to be resolved in the design of the equipment, but it appears that solutions can be obtained by developmental modifications of existing devices, and predevelopment tests to obtain certain basic data.

Selection of the maximum length of cable fairing between terminal points can be made on the basis of the Eames' hydrodynamic loading assumptions (4) once the maximum towing speed has been set and the "stretch" characteristics of the fairing determined. An answer derived from the Eames' loading functions should be conservative, as noted earlier.

With respect to the problem of connecting the double-armor cable to the module terminals, an alternate method is available, using swaged lead fittings. Several companies have developed this art to a fairly high level of sophistication. It thus appears reasonable to expect that the problem can be resolved with only a moderate amount of development.

Two problems were mentioned in connection with the handling equipment: passage of module "lumps" through the "Caterpuller" and slip of the cable relative to the fairing. The existence and severity of these problems can be established with relatively inexpensive tests. Simulated modules of various sizes could be clamped to a three-quarter-inch-diameter cable and passed through a "Caterpuller." Similar tests can be conducted with a short length of almost any existing fairing,

utilizing cables of various diameters to simulate a range of t/d ratios. Questions concerning the use of metal clips on the fairing can be resolved at the same time.

The remaining impediment, the high unit cost of cable fairing, requires the development of mass-production techniques and procurement orders for large quantities. It is understood that a contract for the development of such techniques has been awarded to the Marsh and Marine Company of Houston. In consideration of the solution of many seemingly more complex mass production problems, it appears reasonable to expect success in this area.

CONCLUSIONS AND RECOMMENDATIONS

CONCLUSIONS AND RECOMMENDATIONS

The results of this study indicate that a towed oceanographic instrument system capable of measuring and recording data from depths as great as 5000 feet is now possible. Certain problems remain to be solved; they are primarily of a mechanical nature, however, and should be solved by a moderate additional development and test program.

It is felt that the inherent advantages and increased capabilities offered by this concept justify a development effort to produce an operational system.

In concurrence with the majority of oceanographers consulted, it is recommended that such developmental work be directed toward the demonstration of feasibility of hydro-mechanical specifications with minor emphasis on instrumentation problems. It is further recommended that work be initiated at an early date to resolve the few remaining technical problems.

APPENDIX I

PRELIMINARY DESIGN OF A DEPRESSOR FOR THE TOWED, VERTICAL-
INSTRUMENTATION ARRAY

this heavy type of depressor. Moreover, the present design should have relatively high damping, so that the effect of disturbances should not prove serious.

Although a detailed structural investigation was not undertaken, an abbreviated analysis was made and the results indicate that no serious structural difficulties need be expected.

HYDRODYNAMIC DESIGN

Weight, Lift, and Drag; Pitching Moments

The DEFINITION SKETCH shows the depressor with biplane wing and biplane horizontal stabilizer and defines, by illustration, the principal linear dimensions relating the positions of the wing, stabilizer, and towpoint. The distances x_W and x_H are the horizontal spacings of the mean quarter-chord points of the wing and stabilizer forward and aft of the towpoint, respectively. A longitudinal reference axis fixed on the body and passing through the towpoint is chosen so as to lie in the intended streamwise direction when the depressor is in steady tow. The sketch also illustrates the pitch angle, θ , defined by the inclination of the longitudinal reference axis with respect to the direction of motion. The incidence angles i_W and i_H are likewise defined as the inclinations of the chords of the cambered wing and horizontal stabilizer, both with respect to the longitudinal reference axis of the body.

The sketch illustrates also the lift and drag forces, L_W , L_H , D_W , and D_H , produced by the wing and horizontal stabilizer, and the hydrodynamic moments M_W and M_H , all referred to points at the quarter-chord and mid-gap positions of the biplanes. These last points on the wing and tail are further related to the reference axis by the vertical spacings h_W and h_H .

To attain the desired hydrodynamic downforce and the trim condition, $\theta = 0$, and to provide static stability in pitch

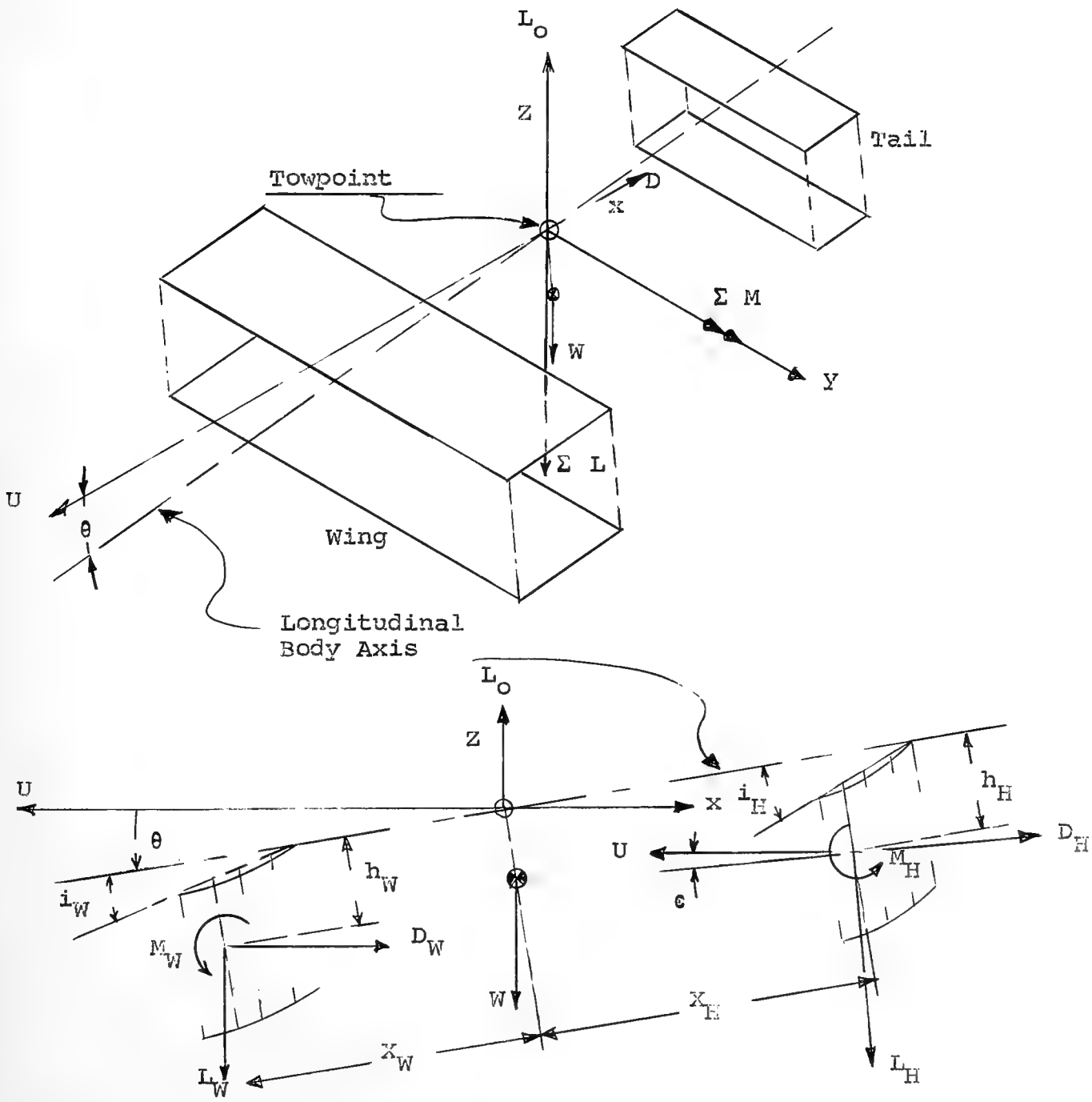

Definition Sketch for Hydrodynamic Design of the Depressor

about the towpoint, three conditions must be satisfied:

$$\Sigma L = L_0 - W \quad [1]$$

$$\Sigma M = 0 \quad [2]$$

$$\frac{d}{d\theta} \Sigma M < 0 \quad [3]$$

when $\theta = 0$.

Here ΣL is the total vertical hydrodynamic force; ΣM is the total force moment about a transverse axis through the towpoint; and W is the weight of the body in water.

We now define the following:

ρ , : density of the fluid;

U , : velocity of tow;

q , : dynamic pressure, $\rho U^2/2$;

D_W, D_H , : drag of wing and tail, respectively;

\bar{C}_W, C_H , : mean chord of wing, and chord of horizontal tail surface;

S_W, S_h , : lifting surface area of wing and horizontal tail;

ϵ , : "downwash" angle (inclination of fluid streamlines relative to the remote flow) at the tail;

L'_W, L'_H , : lift coefficients, $L_W/q S_W, L_H/q S_H$;

D'_W, D'_H , : drag coefficients, $D_W/q S_W, D_H/q S_H$;

M'_W, M'_H , : moment coefficients, $M_W/q S_W \bar{C}_W, M_H/q S_H C_H$;

With the further notation that an appended subscript " θ " denotes differentiation with respect to pitch angle, conditions

[1], [2], and [3] may be written:

$$\Sigma L = q S_W L'_W + q S_H (L'_H - \epsilon D'_H) = L_O - W \quad [1a]$$

$$0 = L'_W S_W x_W + D'_W S_W h_H + M'_W S_W \bar{C}_W \\ - (L'_H - \epsilon D'_H) S_H x_H + (D'_H + \epsilon L'_H) S_H h_H \\ + M'_H S_H C_H \quad [2a]$$

$$0 > (L'_{W\theta} + D'_{W\theta}) S_W x_W + (D'_{W\theta} - L'_{W\theta}) S_W h_W \\ - \left[L'_{H\theta} + \epsilon (1 - \epsilon_\theta) L'_H - \epsilon D'_{H\theta} + (1 - \epsilon_\theta) D'_H \right] S_H x_H \\ + \left[D'_{H\theta} + \epsilon (1 - \epsilon_\theta) D'_H + \epsilon L'_H - (1 - \epsilon_\theta) L'_H \right] S_H h_H \quad [3a]$$

Equations [2a] and [3a] do not include the moment due to the body's weight-in-water. It is intended, however, to specify the location of the ballast so as to place the effective center of the gravitational forces directly below the towpoint when the depressor assumes the design condition, $\theta = 0$, in tow.

In the preliminary choice of the dimensions of the depressor, the drag was neglected and various ratios of S_H to S_W , aspect ratios, and wing-tail separations were tested until a suitably compact configuration was obtained. Moderately large gap-to-span ratios, G/b , and gap-to-chord ratios, G/\bar{C} were chosen to minimize biplane interference effects. Also, biplanes of equal span and area and with zero stagger were selected. On this basis, a preliminary configuration was obtained and the values of the areas, aspect ratios, and overall length and height fixed. At this stage, camber and wing and stabilizer incidence

had not been fixed. The complete equations were then used to refine the estimates of wing and tail incidence and camber needed to satisfy design requirements. For this purpose, all quantities in [1a], [2a], and [3a] are expressed in terms of the effective angles of attack of the wing and horizontal stabilizer. For the condition, $\theta = 0$, the latter are respectively, $i_W + \beta_W$ and $i_H + \beta_H - \epsilon$. Here $(-\beta)$ is the angle of zero lift in the free-stream characteristic of the biplane wing or tail.

If, for brevity, we write ω for $i + \beta$ and designate by "a" the slope of the lift curve (i.e., the derivative of the lift coefficient with respect to angle of attack), the required identities may be written, in the case, $\theta = 0$:

$$\begin{aligned}
 L'_W &= a_W \omega_W & ; & & L'_H &= a_H (\omega_H - \epsilon) \\
 D'_W &= D'_{WP} + D'_{Wi} & ; & & D'_H &= D'_{HP} + D'_{Hi} \\
 M'_W &= M'_{OW} & ; & & M'_H &= M'_{OH} \\
 L'_{W\theta} &= a_W & ; & & L'_{H\theta} &= a_H (1 - \epsilon_\theta) \\
 D'_{W\theta} &= D'_{Wi\theta} & ; & & D'_{H\theta} &= D'_{Hi\theta}
 \end{aligned} \tag{4}$$

Here D'_p is the profile drag coefficient, assumed independent of angle of attack; and D'_i is the induced-drag coefficient assumed given by

$$D'_i = \frac{L'^2}{\pi A} (1 + \delta + \sigma)$$

where A is the the aspect ratio, b^2/S ; b is the span; δ is a tip correction factor for the isolated monoplane of equivalent aspect ratio; and σ is the biplane interference factor for finite aspect ratio (Reference 6).

The values M'_{OW} and M'_{OH} depend upon the camber of the airfoils, being zero for symmetrical foils. Reference 6 gives $M'_O = -\frac{\pi}{2} \beta$. Also, M'_O is independent of angle of attack so that M'_O does not appear the expression for static stability, Equation [3a].

For thin airfoils of small circular arc camber, 2β is half the angle subtended by the arc. Thus the camber f (maximum height of the mean camber line above the reference chord) is $\beta C/2$.

The lift curve slope, a , for a biplane may be deduced from the expression for the induced angle given by Reference 6;

$$a = \frac{a_o}{1 + a_o \left[\beta' + \frac{1 + \tau + \sigma}{\pi A} \right]}$$

where a_o is the lift curve slope of the lifting surface for infinite aspect ratio; τ is a second tip correction factor for the isolated monoplane airfoil of equivalent aspect ratio; and β' is the biplane interference correction for infinite aspect ratio. The equivalent aspect ratio of a biplane consisting of equal areas and spans is identically the aspect ratio of the isolated wings.

The downwash angle is expressed in terms of the value obtaining at the position of the idealized lifting line for an elliptic spanwise load distribution. The latter quantity, designated ϵ_0 , is equal to $L'_W/\pi A_W$. The downwash angle far behind the wing approaches twice the value ϵ_0 . Some reduction, however, occurs from viscous losses. Also the value is reduced in the region above and below the vortex sheet. An estimate of the latter reduction is given by Glauert (Reference 6) for spanwise position as a function of the ratio of height above the vortex sheet to the semispan. The approximate value of the average height of the horizontal stabilizer planes above the zero lift lines of the two wings for the initial configuration is $0.46 \frac{b_W}{2}$. The value of the downwash at that position above the wing was taken to be ϵ_0 .

On the basis of the equivalence in the induced drags, the downwash of the biplane is greater than the downwash for the equivalent isolated monoplane by the amount $\frac{\sigma L'}{\pi A}$, and the expression for the downwash angle at the tail plane is finally $\epsilon_0 (1 + \sigma)$ (Reference 6, p. 187).

Finally, to express equations [1a] and [2a] completely in terms of ω_W and ω_H , we need only fix β . This was done by imposing the condition that the remote flow be tangent to the mean camber line of the airfoil at the leading edge. Since, for small circular arc camber, this condition is

satisfied if $i = 2\beta$, the middle pair of Equations [4] become

$$M'_W = -\frac{\pi}{2} \frac{\omega_W}{3} ; M'_H = -\frac{\pi}{2} \frac{\omega_H}{3} .$$

Values of the parameters defining the final configuration are given in Table 1, and the resulting geometry is shown in Figure 3 in the body of the report.

The gravitational force and moment were then estimated to verify that the values initially estimated could be obtained with reasonable volume of ballast. This was found to be the case.

Since considerable uncertainty attends the prediction of the downwash angle, provision must be made for adjusting the horizontal stabilizer incidence. As it is not convenient to adjust the entire stabilizer assembly, an elevator should be provided for this purpose.

The uncertainty in the actual effective value of the downwash is, at most, ϵ_0 . From Table 1, $L'_W = 0.75$. Therefore

$$\begin{aligned} \epsilon_0 &= \frac{L'_W}{\pi A} = \frac{0.75}{3.25\pi} = 0.0734 \\ &= 4.2 \text{ degrees.} \end{aligned}$$

The elevator must thus provide for a minimum rotation of the horizontal stabilizer zero-lift-line of ± 2.1 degrees. For design purposes, we shall arbitrarily triple the required range by requiring a shift in the horizontal stabilizer

zero-lift line of 6 degrees for a 20-degree elevator deflection, i.e., an elevator effectiveness ($\Delta\alpha_H/\Delta\delta$) of 0.3. This condition is theoretically satisfied for a flap-to-stabilizer chord ratio of only 0.05 (Reference 7). Effectiveness factors of this magnitude are rarely obtained in practice, however, and experimental evidence (Reference 8) indicates that the flap-to-stabilizer chord ratio should be as much as 0.125 for installations with sealed gaps. If a sealed gap is not used, a ratio of not less than 0.2 should be selected.

Lateral Forces; Yaw and Roll Moments

The balance of forces in the lateral plane must satisfy the relations

$$\Sigma F_y = 0 \quad [5]$$

$$\Sigma M_z = 0 \quad [6]$$

$$\Sigma M_x = 0 \quad [7]$$

$$\frac{d}{d\phi} (\Sigma M_x) < 0 \quad [8]$$

$$\frac{d}{d\psi} (\Sigma M_z) < 0 \quad [9]$$

Here ΣF_y is the sum of all lateral forces; ΣM_z is the sum of all moments about the vertical axis; ΣM_x is the sum of all moments about the longitudinal axis. It is, of course, required that the above conditions be met for zero values of roll angle ϕ and yaw angle ψ .

Conditions [5], [6], and [7] are met if the depressor

is symmetrical about the x-z plane while [8] is satisfied by positioning the center of weight-in-water below the towpoint.

With respect to yaw, the principal destabilizing elements of the configuration are the vertical struts connecting the main wing panels and, since both the wing struts and vertical stabilizers are symmetrically disposed, we may write for Equation [9]:

$$\frac{d}{d\psi} (\Sigma M_z) \approx a_s S_s x_s q - a_v S_v x_v q_t$$

where subscript s denotes the forward struts and v the vertical stabilizers. The tail efficiency factor, q_t/q , must be considered since the span of the vertical stabilizer passes through the wake of the lower wing. Since the gap-to-chord ratios of both wing and vertical stabilizer struts are large, and since each is effectively end-plated by the wing and horizontal stabilizer, we may assume, $a_s = a_v = a_o$. Then assuming $q_t/q = 0.8$, we need only require $0.8 S_v x_v > S_s x_s$. From Table 1, $S_v = 4.6$ sq ft; $s_v = 3.77$ ft; $S_s = 1.37$ sq ft; and $x_s = 0.51$ ft. A more refined estimate of stability in yaw would include the contributions of the horizontal lifting surfaces, the bulbous housings, and the remaining parts of the structure. But this appears to be unnecessary.

TABLE 1

GEOMETRIC PARAMETERS FOR THE VERTICAL PROFILE
INSTRUMENTATION DEPRESSOR

GENERAL

Total Wing Area	S	39.75 sq ft
Towpoint Location		30% L*
Tail Length	x_H	4.5 ft
Overall Length	L*	6.42 ft
Overall Height		3.0 ft
Overall Width		6.54 ft

WING

Biplane Area	S_W	26.5 sq ft
Aspect Ratio	A_W	3.25
Mean Chord	\bar{C}_W	2.02 ft
Taper Ratio	λ_W	0.6
Span	b_W	6.56 ft
Camber Factor	$\beta = 2f/C$	0.0788
Lift Coefficient	L'_W	0.755
Lift Curve Slope	$L'_{W\theta}$	3.18
Incidence	i_W	9°
Gap	G_W	2.5 ft
Camber of Root	f_r	0.10 ft
Camber of Tip	f_t	0.06 ft

HORIZONTAL STABILIZER

Biplane Area	S_H	13.25 sq ft
Aspect Ratio	A_H	4.1
Chord	C_H	1.225 ft
Span	b_H	5.0 ft
Taper Ratio	λ_H	1.0
Camber Factor	$2f/C$	0.024
Lift Coefficient	L'_H	0.255
Lift Curve Slope	$L'_{H\theta}$	3.56
Incidence	i_H	8.1°
Gap	G_H	2.0 ft

VERTICAL STABILIZER

Biplane Area	S_V	4.6 sq ft
Chord	C_V	1.15 ft
Taper	λ_V	1.00
Rudder Chord	C_{vr}	0.235 ft (0.2 C_V)
Lever Arm	x_V	3.77 ft

WING STRUTS

Effective Strut Area	S_S	1.38 sq ft
Chord	C_S	0.275 ft
Taper Ratio	λ_S	1.00
Lever Arm	x_S	0.51 ft

APPENDIX II

INSTRUMENTATION FOR MEASUREMENT OF TEMPERATURE PROFILE

APPENDIX II

INSTRUMENTATION FOR MEASUREMENT OF TEMPERATURE PROFILE

INTRODUCTION

This section presents the design of an electronic instrument system for continuous temperature recording at each of a large number of points along the 6000-foot cable of the towed system described in the preceding sections of this report. The purpose of the detailed design is to provide an embodiment of the basic concept of the deep-towed vertical chain of sensors, first, as a demonstration of feasibility and, second, as the preliminary design of a practical instrument system for obtaining data of primary interest in oceanography.

A towed, vertical-profile, temperature-sensing chain, currently in use by Woods Hole Oceanographic Institution, is described in (2). It contains 22 thermistors equally spaced along its 900-foot length. The cross-sectional area of the faired chain is large enough to accommodate separate electrical leads connecting the thermistors to the shipboard sampling and recording apparatus.

By contrast, the present system calls for one hundred or more measuring points spaced along 6000 feet of cable, the cross-sectional area of which is sufficient to accommodate only about twenty electrical leads of reasonable size and insulation.

In the scheme adopted, the sampling of the various temperature and depth sensors is accomplished by time-sharing multiplexing employing a binary code transmitted along seven electrical conductors extending the length of the cable. The use of a seven-digit binary code allows the use of any number of modules up to 128. The number of modules may be doubled by the addition of another digit. The electronic equipment for decoding the switching signal, which interrogates each sensor in turn, is contained in the individual module. The module, when interrogated, transmits a carrier the frequency of which is controlled by its temperature or depth sensor. All power and switching signals are shipboard generated.

The electronic measurement system thus conforms to the modular concept of the basic cable-and-body vertical sensing array. The number of modules, and hence of measuring points, is variable and essentially unlimited. Modules are completely interchangeable (except for an identifying binary number carried on an easily removable coded card) and the type of sensor may be varied from module to module without change in the remainder of the system.

Figure 14 is a simplified block diagram of a telemetering system which incorporates switching circuits to control the action at each module. Additional features and details are given below in descriptions of the various sub-divisions of

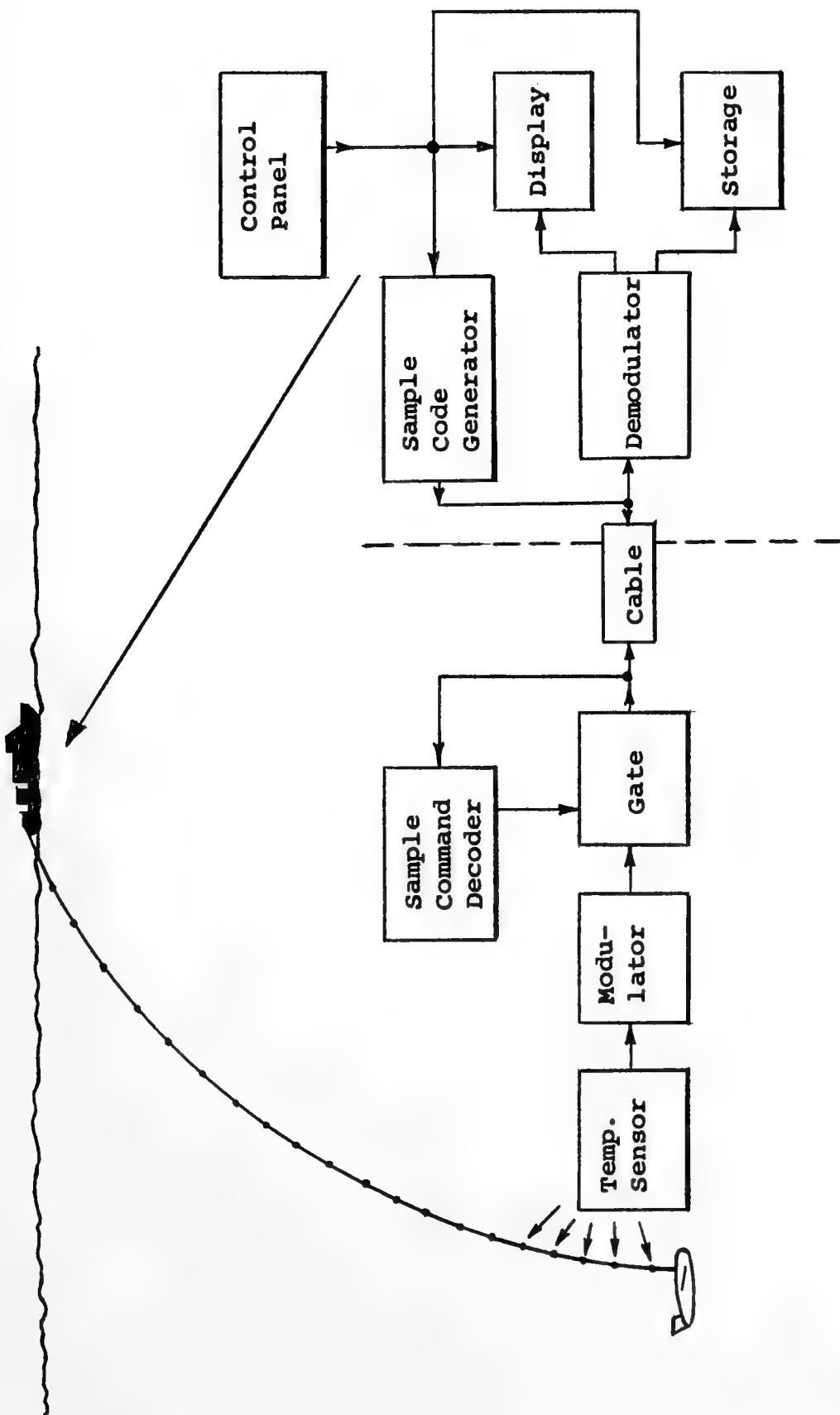

Figure 14 - Temperature Profile Instrumentation
Block Diagram

the system. Critical sections of the electronic switching and gage circuits have been breadboarded. Stated scanning rates and signal frequencies may be considered merely as typical, since these may be fixed variously as required in an actual system.

SHIPBOARD EQUIPMENT

Figure 15 shows the shipboard equipment in block diagram. For purposes of description we consider in order: the power supply; the gage-selection control circuitry; digital display and printer; and the analogue display.

The power to operate all gage packages is derived from a single power supply. A variable transformer is adjusted either manually or automatically to maintain the current at one ampere regardless of the number of gage packages operative in the chain. The power is led to the individual packages through a transformer in each module where the output of the secondary is rectified and used to power the package. The primary windings of all the gage packages in the chain are connected in series. Thus, in the event of a short or open circuit anywhere in the secondary side in a module, the remaining modules will continue to receive power in the proper amount. This "fail-safe" arrangement is employed also in the control and calibration circuits described below.

Approximately 330 volts will be required to operate 128 gages with 5000 feet of cable if a conductor of No. 22 copper wire is used for the power. The return wire will be the outer steel armor of the cable or an internal heavy gage lead. The power-supply frequency may be 60 cycles, although 400-cycle power is preferable in that it allows smaller transformers

TO CABLE
10 LEADS
PLUS
COMMON GROUND

GAGE SIGNALS
6.2 K.C. to
11.0 K.C.

DIGITAL DISPLAY & PRINT

ANALOGUE DISPLAY

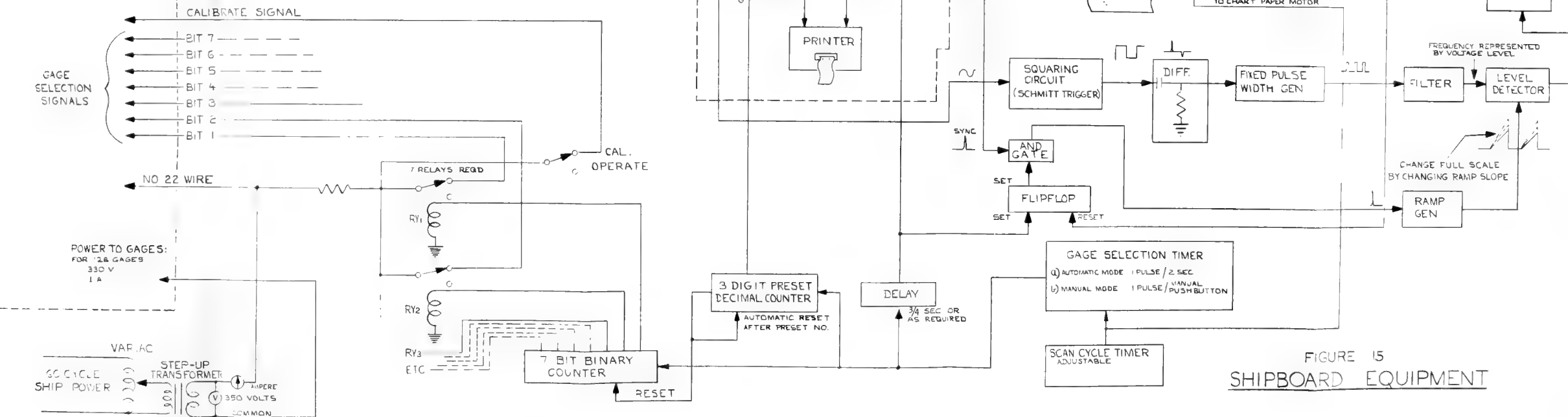

FIGURE 15
SHIPBOARD EQUIPMENT

in the modules. Other conductors in the cable will be: seven gage-selection control wires; one or two calibration control wires; and one conductor for returning the gage signal.

The gage-selection control consists of a timer which generates pulses at two-second intervals, a seven-bit binary counter which operates seven relays in such sequence as to range through all the binary digits from 0000000 to 1111111, and a 3-digit decimal counter the function of which is to reset the binary counter after the latter has covered the range that includes the total number of instrument packages. Each of the relays, when operated, sends a CW signal derived from the power supply down one of the seven gage-selection control wires. The combination of seven "on" or "off" CW signals is decoded in each package in such a way that only one of the packages sends back an FM gage-reading signal. Provision is made for a manual reset of the binary counter and for manual selection of the binary-coded sampling signal.

Thus, in automatic operation, the control circuit interrogates the whole chain at the rate of one reading each two seconds and automatically repeats the cycle. The operation may be interrupted and varied manually at any time.

Since the primary purpose of this study was to determine the feasibility of obtaining data from a chain of sensors

strung out on a 6000-foot cable, no detailed consideration has been given to the display and recording problem. In fact, no aspects of the display, recording, or processing in the system shown are peculiar to the use of a deep-towed instrument chain. The display and recording equipment indicated in the block diagram may therefore be considered as illustrations of a wide class of available equipment.

A feature of the digital display and printer shown is that the digit representing the temperature or depth is obtained directly by counting the number of cycles in the FM gage signal for a selected interval of time. The display and print-out may be made direct reading in, for example, degrees Centigrade simply by proper selection of the counting-time interval and a "bias count" which the counter adds to or subtracts from the total count of cycles occurring in the counting-time interval. The only requirement on the relation between the measured quantity and the gage-signal frequency is that it be a linear one. As an example, suppose that the gage-signal frequency is 6200 cycles per second at 0° C, 11,000 cycles per second at 30° C. A decimal counter which counts for 0.625 seconds and subtracts 3875 from the resulting count will read out temperature directly in hundredths of a degree C.

The analogue temperature plotter indicated employs conventional circuitry to convert the frequency of the gage signal

to a proportionate voltage. The display gives a temperature profile graphically. More sophisticated apparatus for presenting the data in various forms is readily adaptable to the gage system described.

GAGE PACKAGES

Figure 16 details the electrical circuitry of a modular package for measuring temperature. The temperature sensor consists of a pair of thermistors which control the frequency of a Wien-bridge oscillator. Tests have shown that, with suitable padding resistors, the frequency can be made a linear function of the temperature. Typically, the oscillator frequency may be made to vary from 6000 cycles per second at 0° C to 12,000 cycles per second at 30°C. In this way, by means of a shipboard counter and timer, direct digital readout of temperature may be obtained.

Figure 16 shows also the seven "bit" circuits which decode the control signal. Each bit circuit has two outputs of opposite polarity. The polarities are interchanged when the primary winding of the transformer is caused by the control signal to carry current. The binary number identifying a package is determined by the seven binary choices involved in connecting one of the two outputs (A or \bar{A} , B or \bar{B} , etc.) of each of its seven bit circuits into the 7-input "and" circuit. The carrier oscillator, the frequency of which is controlled by the measured temperature or pressure, will be turned on only if all seven inputs to the "and" gate are of the proper (same) polarity. Thus, each of 128 different packages can be interrogated separately by the proper combination of the presence or absence of exciting

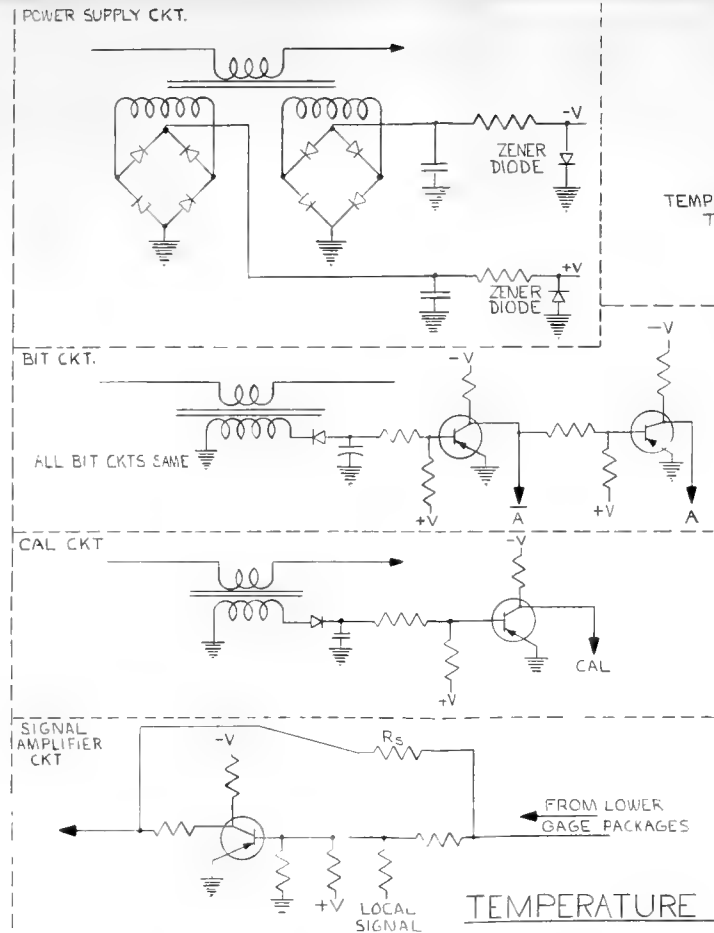
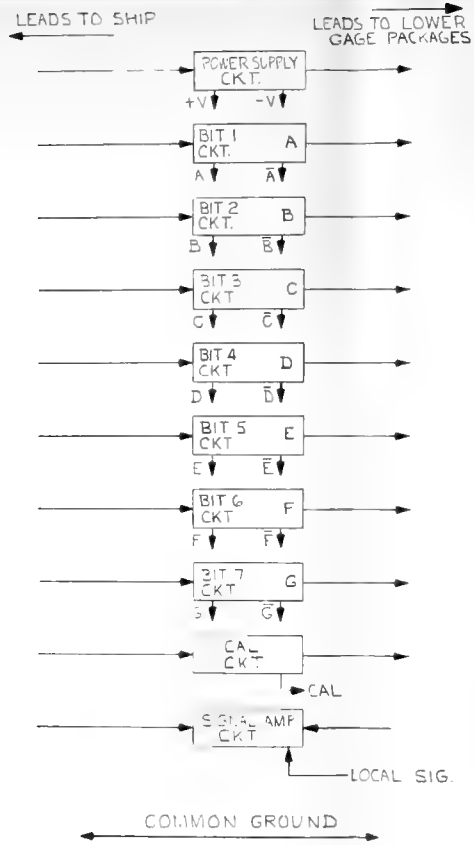

TEMPERATURE MEASURING THERMISTOR

TEMPERATURE MEASURING THERMISTOR

FIGURE 16
TEMPERATURE MEASURING GAGE PACKAGE

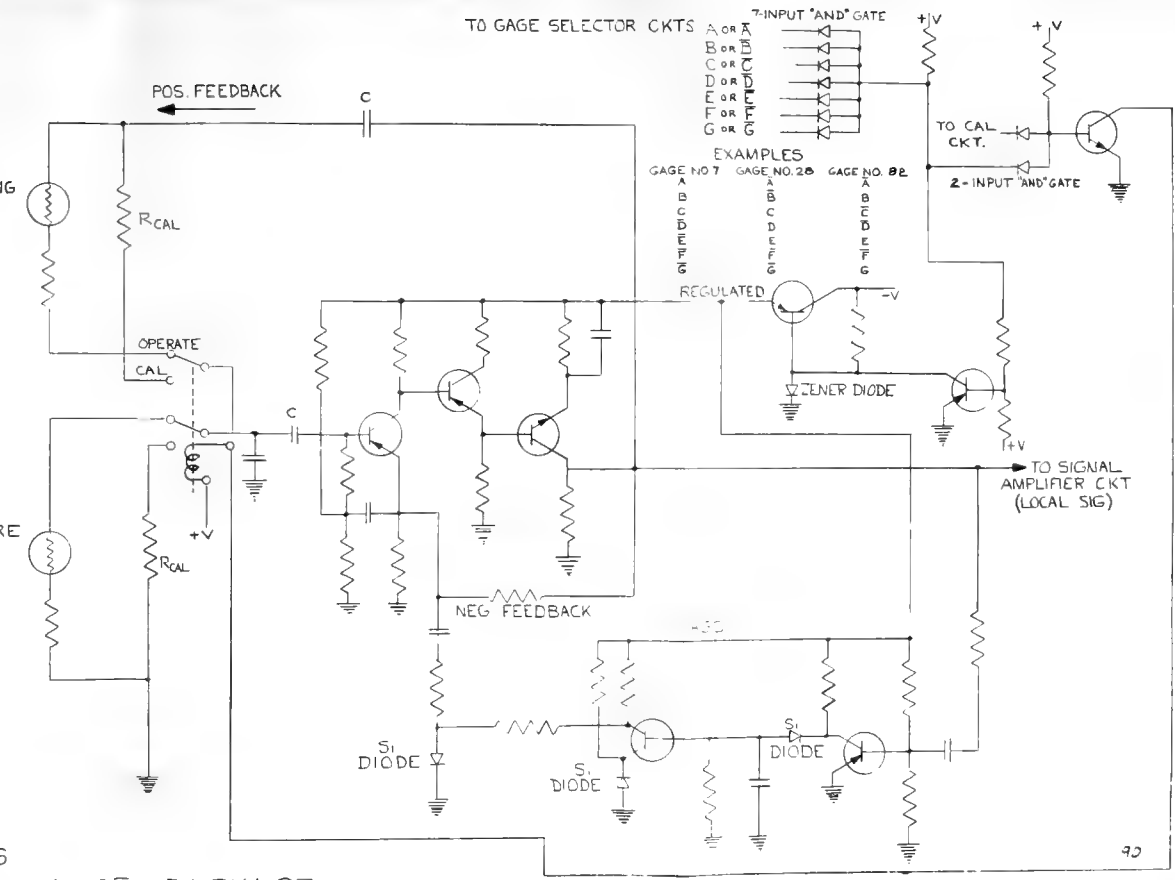

current in seven control lines. The primaries of the "A" transformers in all of the packages are connected in series; similarly the "B" transformers; etc. Thus, the control circuits have the same "fail-safe" feature as the power circuit.

Calibration of the temperature and pressure sensors is accomplished by remotely switching the frequency control of the telemetering oscillator to one or more sets of calibrated resistors. Switching is accomplished by sending a control signal which excites the primary windings of the calibration circuit transformers of all packages. The output from the secondary is rectified and caused to operate a relay which effects the necessary switching from sensor to calibration resistors. In order to avoid the unnecessary power drain incurred by operating relays in all packages, the calibration signal is applied to a 2-input "and" gate along with the output of the 7-input control "and" gate so that only the relay in the package being interrogated is operated. Inclusion of one calibration circuit allows the control of the oscillator frequency to be switched from sensor to one set of calibration resistors. Addition of a second calibration circuit would add two more calibration points, should this be desirable. It is probable that one circuit will suffice since the real purpose of the "calibration" is to apply a check on the proper operation of the telemetering system.

A very small number (perhaps three) of pressure measuring packages will be required to indicate the depth of the temperature sensors. The pressure gage will control the frequency of an oscillator and the package will be scanned in the same manner as the temperature packages. To obtain the required accuracy of pressure measurement pressure transducers of a precision strain gage type may be required. For use with these, precision sub-carrier type oscillators, commercially available, will be modified to suit the requirements of the system.

The signal amplifier contained in each package serves a double purpose: it amplifies the FM carrier generated by the signal oscillator in its own package and, when a gage farther down the chain is being sampled, transmits the FM signal from below on up the chain. The fail-safe feature afforded by the use of transformers in the power, control, and calibration circuits is provided in the signal amplifier by isolation resistors. If, for example, one gage package becomes flooded the signal from the lower gages will feed around that amplifier through resistor R_s . The next amplifier will be able to raise the signal to the standard level.

REFERENCES

REFERENCES

1. Ellsworth, W. M.: General Design Criteria for Cable-Towed Body Systems Using Faired and Unfaired Cable; Systems Engineering Division, PneumoDynamics Corporation Report No. TN-SEDU-6634-1, October, 1960.
2. Hubbard, C. J. and Richardson, W. S.: The Contouring Temperature Recorder; Woods Hole Oceanographic Institution, Reference No. 59-16 (Unpublished Manuscript), April 1959.
3. Pode, L.: Tables for Computing the Equilibrium Configuration of a Flexible Cable in a Uniform Stream; David Taylor Model Basin Report No. 687, March 1951.
4. Eames, M. C.: The Configuration of a Cable Towing a Heavy Submerged Body from a Surface Vessel; Naval Research Establishment (Canada) Report PHx-103, November 1956.
5. -----: Description and Application of the "Caterpuller" Tractor Type Capstan; brochure issued by the Entwhistle Manufacturing Corporation (no date).
6. Glauert, H.: The Elements of Aerofoil and Airscrew Theory; Cambridge University Press, 1948.
7. Fehlner, L. F.: The Design of Control Surfaces for Hydrodynamic Applications; David Taylor Model Basin Report C-358, January 1951.
8. Abbott, I. H., et al.: Summary of Airfoil Data; NACA Report No. 824, 1945.

DISTRIBUTION LIST

for

PneumoDynamics (Cleveland Pneumatic) Reports

Office of Naval Research
Washington 25, D. C.

- 1 Attn: Biology Branch (Code 446)
- 1 Surface Branch (Code 463)
- 1 Undersea Warfare (Code 466)
- 1 Special Projects (Code 418)
- 1 Acoustics Branch (Code 411)
- 1 Fluid Dynamics (Code 438)

1 Contract Administrator Southeastern
Area

Office of Naval Research
2110 G Street, N. W.
Washington 7, D. C.

2 Director
Naval Research Laboratory
Attn: Technical Services
Information Officer
Washington 25, D. C.

2 U. S. Navy Hydrographic Office
Attn: Division of Oceanography
Washington 25, D. C.

Chief, Bureau of Ships
Navy Department
Washington 25, D. C.
1 Attn: Code 671D
1 Code 341C
1 Code 688
1 Code 370

Chief, Bureau of Naval Weapons
Navy Department
Washington 25, D. C.
1 Attn: FAME-3
1 RUDC 252

2 Commanding Officer & Director
U. S. Navy Electronics Laboratory
San Diego 52, California
Attn: Code 2250

1 Commander
Hdqtrs., Detachment 2
Air Force Research Division
Geophysical Research Directorate
Laurence G. Hanscom Field
Bedford, Massachusetts

1 Commanding Officer & Director
U. S. Naval Civil Engineering
Laboratory
Port Hueneame, California
Attn: Code L54

1 Commander, Naval Ordnance
Laboratory
White Oak, Silver Spring, Md.
Attn: E. Liberman, Librarian

Commanding Officer
Naval Ordnance Test Station
China Lake, California
1 Attn: Code 753
1 Code 508

1 Commanding Officer
Naval Radiological Defense Laboratory
San Francisco, California

2 Commanding Officer & Director
David Taylor Model Basin
Washington 7, D. C.

1 Commanding Officer
U. S. Naval Underwater Sound
Laboratory
New London, Connecticut

1 Commanding Officer
U. S. Navy Mine Defence Laboratory
Panama City, Florida

1 Commanding Officer
U. S. Navy Air Development Center
Johnsville, Pennsylvania
Attn: NADC Library

1 Hdqtrs., U. S. Air Force
Attn: AFDRF-RD (Lt. Col. Jamison)
Washington 25, D. C.

2 Director, Bureau of Commercial
Fisheries
U. S. Fish & Wildlife Service
Department of Interior
Washington 25, D. C.

1 Army Research Office
Office of the Chief of R&D
Department of the Army
Washington 25, D. C.
Attn: Research Support Division

1 U. S. Army Beach Erosion Board
5201 Little Falls Road, N. W.
Washington 16, D. C.

1 Office of Technical Services
Department of Commerce
Washington 25, D. C.

10 Armed Services Technical Information
Center
Document Section, Arlington Hall
Arlington 12, Virginia

1 Commandant (OFU)
U. S. Coast Guard
Washington 25, D. C.

1 U. S. Naval Postgraduate School
Monterey, California

2 National Research Council
2101 Constitution Avenue
Washington 25, D. C.
Attn: Committee on Undersea Warfare
Committee on Oceanography

1 Director
U. S. Coast & Geodetic Survey
Department of Commerce
Washington 25, D. C.
Attn: Division of Tides & Currents

1 Director of Meteorological Research
U. S. Weather Bureau
Washington 25, D. C.

1 Ordnance Research Laboratory
Penna State University

U. S. Navy Representative
SACLANT ASW Research Center
La Spezia, Italy

2 Director
Woods Hole Oceanographic Inst
Woods Hole, Massachusetts

1 Director, Narragansett Marine
Laboratory
University of Rhode Island
Kingston, Rhode Island

1 Chairman
Department of Meteorology & Oceanography
New York University
New York 53, New York

1 Gulf Coast Research Laboratory
Post Office Box
Ocean Springs, Mississippi
Attn: Librarian

1 Director
Lamont Geological Observatory
Torrey Cliff
Palisades, New York.

1 Director
Marine Physical Laboratory
San Diego 52, California

2 Director
Hudson Laboratories
145 Palisade Street
Dobbs Ferry, New York

1 Director
Applied Physics Laboratory
University of Washington
Seattle 5, Washington

1 Bell Telephone Laboratories
Whippany, New Jersey
Attn: Dr. W. A. Tyrrell

1 Applied Physics Laboratory
Johns Hopkins University
8621 Georgia Avenue
Silver Spring, Maryland
Attn: Mr. George L. Sciolistad

3 British Joint Services Mission
Main Navy Building
19th & Constitution Ave., N. W.
Washington 25, D. C.

3 Canadian Joint Staff
2450 Massachusetts Ave., N. W.
Washington, D. C.

1 Admiralty Research Laboratory
Teddington
Middlesex, England
Via: Chief of Naval Operations (Op-703)
Department of the Navy
Washington 25, D. C.

1 Commanding Officer
Underwater Detection Establishment
Portland, England
Via: Chief of Naval Operations (Op-703)
Department of the Navy
Washington 25, D. C.

1 Cdr. Destroyer Development Group Two
U.S.N. Base
New Port, Rhode Island

1 Cdr. Destroyer Development Group
Pacific
San Diego, California

1 Great Lakes Research Division
Institute of Science & Technology
University of Michigan
Ann Arbor, Michigan
1 Dr. John C. Ayers (above address)

1 Director
Chesapeake Bay Institute
Johns Hopkins University
121 Maryland Hall
Baltimore 18, Maryland

1 Stanford Research Institute
Menlo Park, California

1 Lamont Geophysical Observatory
Bermuda Field Station
St. Georges, Bermuda

1 Director, Marine Laboratory
University of Miami
#1 Rickenbacker Causeway
Virginia Key
Miami 49, Florida

1 Head, Department of Oceanography &
Meteorology
Texas A & M College
College Station, Texas

1 Director
Scripps Institution of Oceanography
La Jolla, California

1 Department of Engineering
University of California
Berkeley, California

1 Head, Department of Oceanography
University of Washington
Seattle, 5, Washington

1 Director, Hawaiian Marine Laboratory
University of Hawaii
Honolulu, Hawaii

1 Director
Arctic Research Laboratory
Box 1070
Fairbanks, Alaska

1 Director
Bermuda Biological Station for Research
St. Georges, Bermuda

1 Laboratory Director
Bureau of Commercial Fisheries
Biological Laboratory
450-B Jordan Hall
Stanford, California

1 Department of Geodesy & Geophysics
Cambridge University
Cambridge, England

1 Allan Hancock Foundation
University Park
Los Angeles 7, California

