





THE LIBRARY
OF
THE UNIVERSITY
OF CALIFORNIA
LOS ANGELES

GIFT





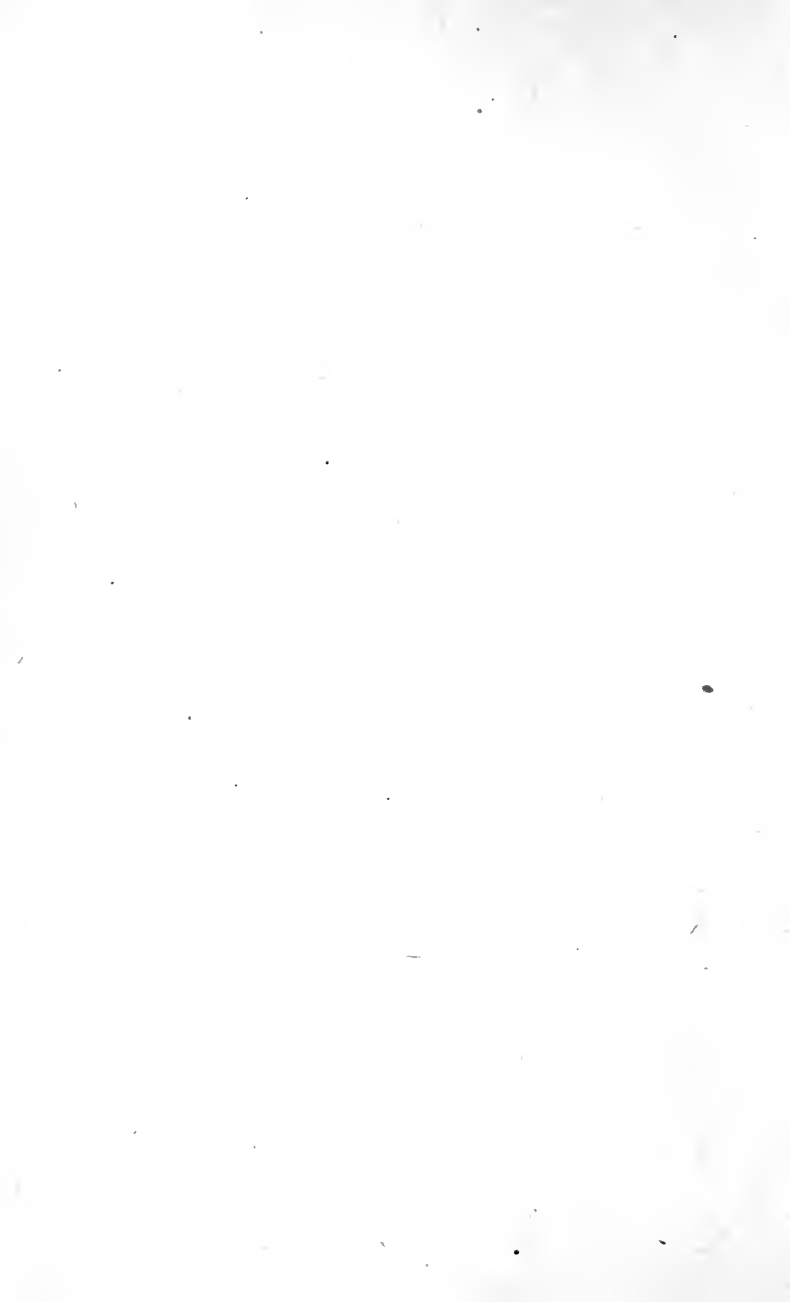

PRIMARY METHODS

A COMPLETE AND METHODICAL PRESENTATION
OF THE USE OF KINDERGARTEN MATERIAL
IN THE WORK OF THE PRIMARY SCHOOL

UNFOLDING

A Systematic Course of Manual Training in Connection with Arithmetic,
Geometry, Drawing, and other School-Studies

BY

W. N. HAILMANN, A. M.

SUPERINTENDENT OF PUBLIC SCHOOLS, LA PORTE, INDIANA

COPYRIGHT, 1887

A. S. BARNES & COMPANY
NEW YORK AND CHICAGO



Education
Library

LB

1169

H12p

TO THE TRUSTEES

OF THE

LA PORTE PUBLIC SCHOOLS

AND TO THE GOOD PEOPLE OF LA PORTE, TO WHOSE SYMPATHETIC AID THE
AUTHOR OWES SO MUCH, THIS VOLUME IS GRATEFULLY INSCRIBED.

1086094

Digitized by the Internet Archive
in 2007 with funding from
Microsoft Corporation

PREFACE

The growing demand among primary teachers for "busy work," "kindergarten methods," and other means of manual occupation, has led to the preparation of this little volume.

Its suggestions have grown in the school-room, and are the results of careful experience and of a thoughtful study of the children's needs, as well as of the drift and value of manual work as an educational factor. In this work I have been much aided by the teachers of the Primary Schools of La Porte, who, with rare intelligence, singleness of purpose, and professional devotion; have enabled me to work out the bearings and possibilities of the work in the various branches of school instruction involved. Whatever credit, therefore, may

come to the book, is largely due to their ready zeal.

It is hoped that this book will not only supply teachers with the needed means and directions for the methodical and systematic, the economical and efficient use of the occupations described, but will also successfully guard them against the evils of random "busy work."

W. N. HAILMANN.

LA PORTE, IND., July, 1887.

CONTENTS

| CHAPTER | PAGE |
|--|------|
| I.—THINGS BEFORE WORDS IN EXPRESSION | 1 |
| II.—THE COURSE OF STUDY | 7 |
| III.—GIFTS AND OCCUPATIONS | 13 |
| IV.—THE WORK SELECTED—OUTFIT | 19 |
| V.—SECOND-GIFT BEADS | 23 |
| VI.—SECOND-GIFT BEADS | 33 |
| VII.—A NUMERAL FRAME FOR EACH PUPIL | 45 |
| VIII.—COUNTING BLOCKS | 53 |
| IX.—COUNTING BLOCKS | 65 |
| X.—FOLDING SHEET | 73 |
| XI.—FOLDING SHEET | 83 |
| XII.—PLASTIC CLAY | 93 |
| XIII.—CUTTING AND MOUNTING | 101 |
| XIV.—CARD-BOARD* WORK | 113 |
| XV.—FRACTION STRIPS | 121 |
| XVI.—SPLINTS OR STICKS | 129 |
| XVII.—STICKS AND PEAS | 139 |
| XVIII.—LENTILS OR DOTS | 147 |
| XIX.—THE GROUP TABLE | 157 |



PRIMARY METHODS.

CHAPTER I.

THOUGHTS BEFORE WORDS IN EXPRESSION.

THE life of man, like all individual life, consists of a series of actions and reactions which constitute the experience of the man. They leave a residue in his consciousness and in his manner of being. The former is the furniture of his insight; the latter, of his conduct. By the former the man is wise; by the latter he is virtuous. Thus experience furnishes the material for the wisdom and virtue which hold all worthy objects of education.

The tenets of Pestalozzian education concede this. "Things before words"; "things before ideas" "first the thing, then its symbol"; "the intellect rests on sense-perceptions"—are utterances of this truth. It has been applied, however, almost exclusively to the in-leading processes in the growth

of intellect. In the out-leading processes we have been satisfied with symbols, with words; we have ignored the value of things. Although we had become aware of the insufficiency of words in the formation of fundamental ideas, yet their inadequacy in fundamental expression has been overlooked. The organs of speech which express ideas in words, were to the school the only road for expression of thought, worthy of its notice. The hand which expresses ideas in things has been neglected.

Similarly, it has been conceded that in the growth of insight, in the formation of accurate ideas, expression is needed as much as impression, that the intellect owes much to the reflex influence which comes from efforts to formulate knowledge in words. But it has been overlooked that the more or less plastic expression of ideas by the hands, with the help of suitable material, holds to their formulation in words very much the same relation that things hold to symbols; that in expression, too, it is necessary to bring things before symbols; things before words.

Thus, in studying the cube, with refer-

ence to its shape, the child will probably at first see the cube, handle it, use it in his games, and thus gain many impressions concerning its shape. These may be expressed in words or, plàstically, in clay. Both modes of expression will react favorably upon the child's idea of the shape; yet there is no doubt that the efforts at plastic representation will be the more effectual mode to clear his idea of inaccuracies and insufficiencies. At every step the child has opportunities to compare his representation of his idea with the idea and with the original, to correct faults and to supply omissions.

Again, it may be possible to give the child a fair idea of a square by showing him square pieces of paper, square figures, square objects, and by accompanying this with judicious instruction and skillful questioning on the details of the form; yet all this is but the glare of gas-light compared with the noonday light that is poured into the pupil's mind by the actual handling of squares, by using them in the construction of other forms, by drawing squares singly or in symmetrical groups, by cut-

ting such forms from paper, pasteboard, or wood, by fashioning them from clay or wax.

It will be readily seen that this hand-training has wider aims than industrial training in the various arts. Industrial training supplies some particular or transient need of self-preservation; whereas the aims of the hand-training here proposed lie in general and permanent self-expansion. Hand-training in this sense is as much a need of the professional and literary man, of the merchant and clerk, of the capitalist and land-owner, as it is of the artist and artisan, of the laborer and farmer; as much a need of woman as it is of man; its need rests on the immanent being of man, not on transient industrial circumstances.

Industrial work selects its material primarily in accordance with the use to which its products are to be put, whereas the hand-training here proposed looks primarily, in the selection of materials, to the capacities and needs of the little workers. Here it is of the first importance that the material should yield readily to the worker's limited skill. It should be of such a

shape and character that it will adapt itself without worry to the worker's aim, so that he may reach automatism in manual expression as readily as he does in speech; it should, therefore, be so prepared that the arranging and transforming activities of the hand may receive ready answers, as is done to a large extent in the materials suggested by Froebel.

The business of life is adaptation to surroundings, to nature, to the universe. This implies knowledge and control of self and surroundings. The business of education is to lead the young human being on the surest and shortest road to this adaptation. Education should see to it that the income of the senses be properly interpreted and appreciated by the mind, and that the tongue and the hands properly represent the mind and execute its behests. The mind should learn to rely implicitly upon its powers to see, say, and do. In seeing, saying, and doing, it should acquire the habit of success, a calm sense of power, a firm conviction of mastership. This is possible only, if head and hand are trained simultaneously and in unison with each

other; and for this purpose the hand-training here proposed is needed in the school.

The advocates of industrial training are met with the objection that the school is already loaded down with work, and that it will be ruinous to the child to add fresh burdens. The hand-training here proposed is not open to this objection; *it removes burdens*. It enables the child to gain the knowledge which the current subjects of school instruction represent, in a manner more suited to his tastes and powers; in a complete, all-sided, active, ideal child-life in which he is upheld and strengthened by the constant joy of success, the steady glow of growing power.

The chief object of this book is to show how this may be accomplished, to lay before the teachers the possibilities of available material, to indicate its many-sided applicability to primary school work, and to suggest in a number of model lessons modes of directing their life-giving sunshine into the school-room.

CHAPTER II.

THE COURSE OF STUDY.

IN the work indicated I shall have before me a quasi-ideal average Course of Study, the essentials of which appear in the following considerations:

“In framing a course of study for Primary and Grammar Schools, it should be constantly borne in mind that the period involved corresponds chiefly to the earlier portion of the psychological period of conception. When the child enters school he is still gathering perceptions, though upon some things he has quite clear and comprehensive conceptions; and when he leaves the Grammar School, his intellect should have grown into a fair supremacy, and the dawn of insight into the deeper relations of being should be full upon his mind. During the first years of school life, the subjects of study should be of a character to facilitate the formation of perceptions

and their transition into comprehensive conceptions; they should lie on the side of the concrete, the actual, the outer; they should deal with facts, with space, with objects. They should, then, gradually merge into forms that lie on the side of the abstract, the possible, the inner; that deal with principles, with laws, with time, steadily leading the child out of the complexity of things into the simplicity of thought. * * * The essentials of the outer world that interest man most nearly in his efforts to obtain intellectual control of his surroundings are centered in *space* which in its limits involves *form, position, size, direction,* and *number*. Of these, number and size have a special interest, inasmuch as they constitute the chief bridges in the transition of the mind from outer space to inner time. To these may be added *color* as an important element, depending on certain relations of material surfaces to light. Lying nearer the emotional side of sensation, it has much power to arouse interest in related elements of space, hence its educational value is very great. The school will, then, find the first subjects for instruction with reference to

the pupil's individual development, in the provinces of *Geometry, Drawing, Coloring, and Arithmetic.*

“Almost simultaneously, however, the phenomena of motion and life to which the changes of position, direction, size, form, and number among surrounding objects are referred, and which intensely affect the child's comfort and welfare, point to studies connected with the provinces of *Physics, Chemistry, Natural History, Geography, and Uranography.*

“Long before the child's entrance into school, too, the helpful presence of others aroused in his heart feelings of gratitude, of affection, and good-will. These may or may not have been brought more clearly to the child's consciousness, and more fully within his control in the social games and group-work of the kindergarten. Howsoever this may be, the school should afford constant opportunity for social enterprises, involving common interests, common purposes, and common effort, leading to an interest in the occupations of men, and in the relationships among men. This leads to studies connected with *Sociology and History,*

through which man connects himself consciously with the past, and bases his life on the experience of earlier days.

“In all that relates to motion and life and, consequently, to the social phases of being, *sound*—lying also nearer the emotional side of sensation—plays a part similar to that of color in the realms of space. Connected with rhythm in the harmonious combinations and melodious successions of *music*,—it has wonderful power in freeing the mind from the material, and leading it to the spiritual, and is, therefore, of incalculable value in lifting man to the highest planes of mental life.

“The chief medium of the work is *language*. At the moment when the child is awakened to self-consciousness, language appears as the chief outward reaction of growing self-consciousness in the intercourse with others. Language binds man to man, makes the past an ingredient of the present, and holds this fast for a future. In the development of the intellect and of reason, it is the medium of thought, the indispensable condition of their growth. Hence language, with all that pertains to

it, will furnish subjects of instruction during the entire school-life."*

In the details of the course the school should be guided largely by local and individual circumstances, needs, and wants. In no case, it is true, can the school afford to follow the child through the maze of facts and phenomena, as they occur in nature and in immediate practical experience. Yet, in all cases, it should create around the child a world of objects and events, more or less idealized, and more or less systematized, where the child may attain a fair understanding of the essentials of life with comparatively little friction; and, in all cases, it should strive to place this world as fully as possible within the child's control.

While these remarks apply equally to the Primary and Grammar Schools, it is evident that what I may have to say concerning the use of things in the school-room for purposes of expression will apply chiefly to the work of the Primary Grades. Nevertheless, even a superficial survey of

* Prize Essay: "Application of the Principles of Psychology to the Work of Teaching." By W. N. Hailmann.

the subjects of instruction will show that so far, at least, as Geometry, Drawing, Coloring, Physics, Chemistry, Natural History, Geography, and Uranography are concerned, I might with profit follow the pupil through the highest grade in the grammar school, aiding him in expressing thought in things as well as words. However, this would render my task too cumbersome; and I shall, therefore, not go beyond the pale of the primary school, save in an occasional hint concerning the extension of the work to higher grades.

CHAPTER III.

SYNOPTICAL TABLE OF GIFTS AND OCCUPATIONS— GIFTS AND OCCUPATIONS CONTRASTED.

IN order to enable teachers to choose intelligently the material for the needs of their pupils, I shall present in this chapter a survey of the so-called gifts and occupations selected and proposed by Froebel on the basis of considerations essentially in accordance with the two preceding chapters. Inasmuch as the play-and-work with these things is to lead the children to the study and control of an external world, their formal key lies in shape. There is prominent in them, as a whole, first a mathematical analysis descending from the body, through the surface and line, to the point. This is followed among the gifts by a synthetic gift in which from the point and line the child ascends to less material representations of the surface and body. In the occupations, the synthetic elements are

so intimately and prominently interwoven with their very essence, that one is almost tempted to treat them as the specifically synthetic side of Froebel's scheme.

The following synoptical presentation, although quite different from those generally accepted, is in strict accordance with Froebel's spirit. I have no doubt that he himself would have given us an arrangement not unlike this one, had he found time to look more calmly upon the revelations that came to us through him.

I. GIFTS.

A. BODIES.

I. *Things, objects—(color)*: Six colored soft worsted balls.—*First Gift*.

II. *Shape*: Wooden ball, cylinder and cube.—*Second Gift*.

III. *Number*:

1. Two ($2 \times 2 \times 2$):

a. *Divisibility*: Eight one-inch cubes, forming together a two-inch cube.—*Third Gift*.

b. *Dimensions*: Eight bricks ($2 \times 1 \times \frac{1}{2}$ in.), forming together a two-inch cube.—*Fourth Gift*.

2. *Three* ($3 \times 3 \times 3$):

a. *Direction — (Beauty)*: Twenty-seven one-inch cubes, forming together a three-inch cube. Three of the cubes are cut diagonally once into halves; and three are cut diagonally twice into quarters.—*Fifth Gift*.

- b. *Proportionality and Position (Law)*: Twenty-seven bricks ($2 \times 1 \times \frac{1}{2}$ in.), forming together a three-inch cube. Three of the bricks are cut lengthwise once into square prisms ($2 \times \frac{1}{2} \times \frac{1}{2}$ in.), and six bricks are cut crosswise once into flat square prisms ($1 \times 1 \times \frac{1}{2}$ in.).—*Sixth Gift*.

B. SURFACES.

- I. *Squares* derived from third gift, cut from veneer or card-board.

1. Entire squares (one square inch).—*Seventh Gift A*.
2. Half squares, right isosceles triangles.—*Seventh Gift B*.

II. *Equilateral Triangles*.

1. Entire triangle, each side one inch long.—*Seventh Gift C*.
2. Half triangles, right scalene triangles.—*Seventh Gift D*.

[These were formerly derived, less logically, from a double square or oblong rectangle, cut diagonally.]

3. Thirds of triangles, obtuse isosceles triangles.—*Seventh Gift E*.

- III. *Circles*. [The scheme calls for these, but as yet manufacturers do not furnish them, nor do manuals give directions concerning their use. With a one-inch gun-wad cutter, which may be obtained of any gunsmith, they may be cut cheaply from stiff paper or card-board.]

C LINES.

- I. *Straight Line*: Sticks or splints of various lengths.—*Eighth Gift A*.
- II. *Curved Line*: Rings and half-rings of various sizes.—*Eighth Gift B*.

D. POINTS.

Lentil-seeds, pebbles, beans, etc.—*Ninth Gift.*

E. RECONSTRUCTION. (Synthesis.)

Softened peas and sticks or straws.—*Tenth Gift.*

II. OCCUPATIONS.

A. BODIES.

1. Plastic clay (or substitutes, such as wax, putty, etc.).
2. Card-board.
3. Sand.

B. SURFACES.

1. Folding sheets. (To the square and oblong sheets, suggested by Froebel, I have added the circle and equilateral triangle.)
2. Cutting and Pasting. (Paper, card-board, wood.)
3. Painting. (With brush or crayon, or with the lead or slate pencil in "shading.")

C. LINES.

1. Interlacing slats.
2. Jointed slats.
3. Intertwining strips.
4. Weaving mats.
5. Thread-games.
6. Embroidery.
7. Drawing.

D. POINTS.

1. Stringing beads. (Mrs. Hailmann's Second-Gift beads.)
2. Mrs. Hailmann's lentils or dots.
3. Buttons, papers, and straws, etc.
4. Perforating.

I am aware that the distinction between gifts and occupations is post-Frobelian; but

it is not on that account less real. The *gifts* are intended to *give* the child from time to time new universal aspects of the external world, suited to the child's powers of comprehension. In the schedule the essential features of these are indicated for the first six gifts, by the italicized words introducing the gift. The *occupations*, on the other hand, furnish the child with materials on which to exercise certain phases of skill. Any thing will do for an occupation, provided it is sufficiently plastic and within the child's powers of control; but the gift, in form and material, is largely determined by the cosmic phase to be brought to the child's apprehension, and by the condition of the child's mind. Nothing but the *first gift* can so effectively arouse in the child's mind the feeling and consciousness of a world of individual things and of its own dawning individuality; but there are numberless occupations, in addition to those enumerated in the schedule, that will enable the child to become skillful in the manipulation of surfaces.

The gift gives the child a new cosmos; the occupation fixes the impressions made

by the gift. The gift invites only arranging activities; the occupation invites chiefly controlling, modifying, transforming, creating activities. The gift leans toward the in-leading processes, toward instruction; the occupation toward out-leading process, toward expression. The gift leads to discovery; the occupation, to invention. The gift gives insight; the occupation, power.

CHAPTER IV.

THE WORK SELECTED—OUTFIT OF SCHOOLS.

FROM the mass of material presented in the preceding chapter, I shall select a few gifts and occupations, and show in a series of somewhat detailed directions and “model” lessons how they may be used in the school-room in such a way as to aid in rendering the children’s growth compact, sound, all-sided, and rounded; and, at the same time, in giving them full and ready knowledge and mastership in the directions of ordinary subjects of instruction.

In this, while I shall aim to regard the types best suited to give an insight into the scheme as a whole, I shall be guided largely by considerations of expediency. Thus I shall give preference to those that seem to stand nearest the school as it is, and that will prove most serviceable in the ordinary school studies. Again, I shall consider the cost of the material, and put

more stress upon occupations that may be procured with comparatively little expense, so that teachers may be less exposed to annoying opposition on the part of conservative friends of education.

Probably each teacher, according to the circumstances in which she may be placed, will have to select again from my selection. Possibly, too, some may be able to use material not treated in this volume. In this case I hope my presentations may be sufficiently lucid and comprehensive to enable her to make the new applications independently. Most of all should I rejoice, if what I may say will enable and induce teachers to reach out in their surroundings for new and simpler material, to seek simpler ways of applying the principles that have guided me, and to discover new avenues of usefulness for the materials I may present.

In the order of the schedule of the preceding chapter I shall consider: (1) The counting-blocks, a modification of the third gift; (2) the square and half-square tablets; (3) the sticks or splints; (4) the lentil-seeds; (5) sticks and pease; (6) clay; (7) card-board work; (8) folding; (9) cutting

and pasting; (10) intertwining strips; (11) Mrs. Hailmann's second-gift beads; (12) Mrs. H.'s dots.

For various reasons, however, these will be presented in a different order, more in accordance with the needs of the school, as it is. Thus: (1) Mrs. Hailmann's second-gift beads, with special reference to lessons in number; (2) the counting-blocks, with special reference to number lessons; (3) the folding-sheets, with special reference to drawing and geometry; (4) clay, with special reference to drawing, geometry, and coloring; (5) cutting and pasting and, subsequently, card-board work, with special reference to arithmetic, geometry, and drawing; (6) intertwining strips, with special reference to arithmetic (fractions), geometry, and drawing; (7) the sticks or splints and, subsequently, sticks and pease, with special reference to geometry, drawing, and arithmetic; (8) Mrs. Hailmann's dots and lentils; (9) the square and half-square tablets.

For the majority of the exercises, it is desirable that the child should work upon a surface laid off in square inches, similar to the surface of a kindergarten table. In

my own schools I have found it quite satisfactory to rule such a net-work with a sharp scratch-awl on the ordinary desk-fronts. For many exercises, particularly in group-work—though these are not indispensable—it is desirable to have small tables, thirty inches square and of suitable height. The surface of these, too, is ruled with a net-work of square-inches, and each table accommodates four children. For my own schools I have been able to procure such tables at a trifling cost of \$1.50 a piece, and suitable low stools at \$2.50 per dozen. Other matters of outfit will be mentioned in the proper places.

CHAPTER V.

THE SECOND-GIFT BEADS.*

THE Second-Gift Beads consist of wooden cubes, cylinders, and balls (the shapes of Froebel's Second Gift), one half inch in diameter, colored in the hues of the rainbow—red, orange, yellow, green, blue, violet,—and perforated for stringing.

For the school, they are particularly useful in number lessons. The contrasts of color and form afford effective means for presenting analyses, aiding the mind *through the "sub-conscious"* in the formation of clear notions and ready mastership. This will become evident if we compare the following three typical ways of presenting the number *five*:

- (1) Five cubes (five cylinders, or five balls) of the same color.
- (2) Two pairs of cubes separated by one ball, all of the same color.

* Mrs. Hailmann's Second-Gift Beads are manufactured by the Milton Bradley Company, of Springfield, Mass.

(3) Two pairs of red balls separated by a green ball.

In the first mode (1) it will be found that the little child can not arrive at the unit: *five balls* (or beads), without laboriously counting: one, two, three, four, five. This process constantly tempts him to look upon these *counting* numbers as *names*, and to call the first ball *one*; the second, *two*; the third, *three*, etc. Thus the very unity in the outer fact hinders the growth of the desired corresponding mind unit. In the second mode (2) the contrast in form breaks up the number *five* into the familiar constituents, $2 + 1 + 2$; and these are readily united by the common color into *five BEADS*. Similarly, in the third mode (3), the separation into $2 + 1 + 2$ is made by color, and the common form unites the beads into *five BALLS*.

Another important feature of the work lies in the possibility of arranging the beads in rhythmic waves of form, color, and number. This is illustrated in the following lesson of threes, in which the square (\square) stands for cube; the circle (\circ), for ball; the semicircle (\cap), for cylinder; and the letters for the colors (*r* for red, *o* for orange,

y for yellow, *g* for green, *b* for blue, and *v* for violet):

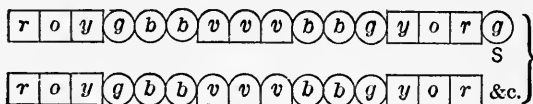

In this exercise two waves are represented, separated from each other by a green bead at the point *S*. The color wave on each side of this bead is as follows: (r-o-y) (g-b-b) (v-v-v) (b-b-g) (y-o-r). The corresponding form wave will be easily read from the diagram. The number wave reads, (1+1+1) (1+2) (3) (2+1) (1+1+1). It will be seen that the second half of the wave is in arrangement the reverse of the first half, descending where the latter ascends.

The outfit for the class is simple. Each child is furnished with a box of 50-100 assorted beads, and a shoe-string, two or three feet long. This outfit is ample for all exercises within the limits of 1 and 10, and admits of many exercises beyond these limits. For a class of twenty children the cost will not exceed \$2.00. One end of the shoe-string is tied to some convenient part

of the desk or table, and the other end is used for stringing the beads.

The beads may be used for all fundamental operations within the limits of one and ten, and one and twenty. In proof of this I suggest below several series of exercises in

(1) Counting by ones, twos, threes, fours, and fives.

(2) Analyses and syntheses of the numbers two to ten.

(3) The making of addition and subtraction tables.

(4) The making of multiplication and division tables.

In the exercises the arrangement of the beads will be indicated with the help of the symbols already mentioned, and the respective number lesson, indicated in figures, will accompany each exercise.

I. COUNTING EXERCISES.

- | | | | | | | | | | | | | | | |
|----|---|---|---|---|---|---|---|---|---|---|------|---|--------------------------|--|
| 1. | g | r | g | r | g | r | g | r | g | r | &c.) | } | (1, 1) (1, 1) (1, 1) &c. | |
| 2. | o | b | o | b | o | b | o | b | o | b | &c.) | | | |
| 3. | v | y | v | y | v | y | v | y | v | y | &c.) | | | |

4. $\boxed{r} \boxed{b} \circ \boxed{r} \boxed{b} \boxed{r} \boxed{b} \boxed{r} \boxed{b} \boxed{r} \boxed{b} \&c.$
5. $\circ \boxed{g} \circ \boxed{g} \circ \boxed{g} \circ \boxed{g} \circ \boxed{g} \circ \boxed{g} \&c.$
6. $\circ \boxed{y} \boxed{r} \circ \boxed{y} \boxed{r} \circ \boxed{y} \boxed{r} \circ \boxed{y} \boxed{r} \circ \boxed{y} \boxed{r} \&c.$
7. $\boxed{b} \boxed{r} \circ \boxed{y} \boxed{b} \boxed{r} \circ \boxed{y} \boxed{b} \boxed{r} \circ \boxed{y} \boxed{b} \boxed{r} \circ \boxed{y} \&c.$
8. $\circ \boxed{g} \boxed{v} \circ \boxed{g} \boxed{v} \circ \boxed{g} \boxed{v} \circ \boxed{g} \boxed{v} \circ \boxed{g} \boxed{v} \&c.$
9. $\boxed{r} \circ \boxed{y} \boxed{r} \circ \boxed{y} \boxed{r} \circ \boxed{y} \boxed{r} \circ \boxed{y} \boxed{r} \circ \boxed{y} \boxed{r} \circ \boxed{y} \&c.$
10. $\circ \boxed{y} \boxed{g} \boxed{b} \circ \boxed{y} \boxed{g} \boxed{b} \circ \boxed{y} \boxed{g} \boxed{b} \circ \boxed{y} \boxed{g} \boxed{b} \circ \boxed{y} \boxed{g} \boxed{b} \circ \boxed{y} \boxed{g} \boxed{b} \&c.$
11. $\boxed{b} \boxed{r} \boxed{g} \boxed{y} \boxed{b} \boxed{r} \boxed{g} \boxed{y} \boxed{b} \boxed{r} \boxed{g} \boxed{y} \boxed{b} \boxed{r} \boxed{g} \boxed{y} \boxed{b} \boxed{r} \boxed{g} \boxed{y} \&c.$
 (1, 2, 3, 4) (1, 2, 3, 4) (1, 2, 3, 4) &c.
12. $\boxed{r} \circ \boxed{y} \boxed{g} \boxed{r} \circ \boxed{y} \boxed{g} \boxed{r} \circ \boxed{y} \boxed{g} \boxed{r} \circ \boxed{y} \boxed{g} \boxed{r} \circ \boxed{y} \boxed{g} \boxed{r} \circ \boxed{y} \boxed{g} \&c.$
13. $\boxed{r} \boxed{b} \boxed{y} \boxed{b} \boxed{r} \boxed{r} \boxed{b} \boxed{y} \boxed{b} \boxed{r} \boxed{r} \boxed{b} \boxed{y} \boxed{b} \boxed{r} \boxed{r} \boxed{b} \boxed{y} \boxed{b} \boxed{r} \&c.$
 (1, 2, 3, 4, 5) &c.
14. $\circ \boxed{g} \boxed{v} \boxed{g} \circ \circ \boxed{g} \boxed{v} \boxed{g} \circ \circ \boxed{g} \boxed{v} \boxed{g} \circ \circ \boxed{g} \boxed{v} \boxed{g} \circ \circ \boxed{g} \boxed{v} \boxed{g} \circ \&c.$
15. $\boxed{r} \boxed{r} \circ \circ \boxed{r} \boxed{r} \circ \circ \boxed{y} \boxed{y} \boxed{r} \boxed{r} \circ \circ \boxed{y} \boxed{y} \boxed{g} \boxed{g} \&c.$
 (2, 4) (2, 4, 6) (2, 4, 6, 8) &c.
16. $\circ \circ \circ \boxed{g} \boxed{g} \boxed{g} \boxed{v} \boxed{v} \boxed{v} \circ \circ \circ \boxed{g} \boxed{g} \boxed{g} \boxed{v} \boxed{v} \boxed{v} \circ \circ \circ \&c.$
 (3, 6, 9) (3, 6, 9) &c.
17. $\boxed{b} \boxed{b} \boxed{b} \boxed{b} \boxed{b} \boxed{b} \boxed{b} \boxed{b} \boxed{b} \boxed{y} \boxed{y} \boxed{y} \boxed{y} \boxed{y} \boxed{y} \boxed{y} \boxed{y} \boxed{y} \boxed{y} \boxed{r} \boxed{r} \boxed{r} \&c.$
 (3, 6, 9) (3, 6, 9) &c.

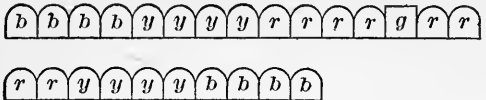
18.  } (4, 8, 12—4, 8, 12)

19.  } (5, 10, 15) &c.

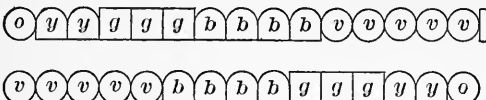
20.  } (1, 2, 3, 4, 5—
5, 4, 3, 2, 1)

In the first three exercises, the members of each pair of beads differ both in color and shape, and the child recognizes them merely as two ones, or (1, 1). It will probably count, *e. g.*, in Exercise 1: “one green cube, one red ball; one green cube, one red ball,” etc.

In the Exercises 4, 5, and 6, on the other hand, the members of each pair, though separated by color into two ones — 2(1)—, are united by shape into one two — 1(2). Reading the fourth exercise by color, the child would say: “One red cube, one blue cube; one red ball, one blue ball,” etc.; or simply: “One red, one blue,” etc. Reading the same exercise by shape, it would say: “Two cubes, two balls,” etc.

Similarly, in Exercises 7 and 8, the members of each set of three differ both in color and shape. The child would count, while stringing (in Exercise 7): "*One* blue cube, *one* red cylinder, *one* yellow ball," etc. On the other hand, in Exercises 9 and 10, the shape gathers the beads into distinct sets of threes. The child would read while stringing (Exercise 9): "*One* red *cube*, *one* orange *cube*, *one* yellow *cube*," etc.; or by shape alone: "*One* cube, *two* cubes, *three* cubes," etc. When the string is finished, it will read from its work, by shape: "Three cubes, three cylinders, three balls," etc.

Similar remarks apply to Exercises 11, 12, 13, and 14. In Ex. 13, the reader will observe color waves, the color ascending in each group of five from red to yellow, and descending on the opposite side from yellow to red. In Ex. 14, the color waves of each group of five are gathered in a larger form wave ascending from the balls to the cubes, and descending on the opposite side from the cubes to the balls. A second wave may be added to this, after indicating the close of the first by means of a cube, clearly contrasting in color with the orange balls.

In Ex. 15—counting by twos—the color separates the beads into sets of twos; and the shape teaches the child to read successively, as it strings the beads or surveys its work: “Two, four (cubes)”; “two, four, six (balls); two, four, six, eight (cylinders).” Here the child may insert an orange ball, in order to mark the highest point of the number wave, and then, reversing the order of colors and shapes, count: “two, four, six, eight (cylinders); two, four, six (balls); two, four (cubes),” etc.

Ex. 16 and 17 suggest the counting by threes. In Ex. 16, the child counts: “three, six, nine (balls); three, six, nine (cubes)”; and repeats this counting at pleasure. Here shape unites the threes, and color keeps them distinct. In Ex. 17, the reverse is the case; color unites the threes, and shape keeps them distinct. Here the child counts: “three, six, nine (blue beads); three, six, nine (yellow beads); three, six, nine (red beads),”—and repeats the exercise at pleasure.

In Ex. 18, shape unites the fours. The exercise presents coinciding shape and color waves, the highest point being marked by a green cube. The child counts: four, eight,

twelve (cylinders); four, eight, twelve (cylinders). It goes without saying that the green cube, marking the highest point of the wave, is *not* counted; also, that before the exercise is repeated, an orange ball must be strung to separate the last blue cylinder of the first exercise from the first blue ball of the repetition.

In Ex. 19, color unites the fives. The highest point of the shape wave is indicated by a yellow cube. The child counts: five, ten, fifteen (red beads); then—omitting to count the yellow cube—five, ten, fifteen (red beads). The repetition of the exercise would call for a green ball to separate the two exercises.

Exercise 20 is an excellent counting exercise. It reads—both in color and shape: “One (orange *ball*), two (yellow *cylinders*), three (green *cubes*), four (blue *cylinders*), five (violet *balls*)”; and from the red cube downward: “Five (violet *balls*), four (blue *cylinders*), three (green *cubes*), two (yellow *cylinders*), one (orange *ball*).”

I trust that these suggestions and explanations will make it easy for the teacher to devise additional exercises, as they may

be needed. The exercises may be dictated orally to the children; or they may be indicated on the blackboard with the help of the symbols used in this book; or the children may be left to invent form and color combinations for given number formulas. The last, however, should not be indulged too soon nor too frequently.

CHAPTER VI.

SECOND-GIFT BEADS. (Conclusion.)

FROM the very nature of the opposite processes, analysis and synthesis, it follows that the same exercises will answer the purposes of both. The inspection of the following typical exercise with the number *three* will show this:

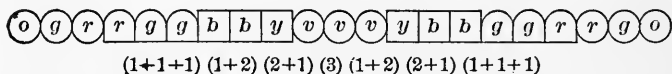

This may be read from left to right synthetically: $1 + 1 + 1 = 3$, $1 + 2 = 3$, $2 + 1 = 3$, $3 = 3$, $1 + 2 = 3$, $2 + 1 = 3$, $1 + 1 + 1 = 3$. Or, it may be read, in the same direction analytically: $3 = 1 + 1 + 1$, $3 = 1 + 2$, $3 = 2 + 1$, $3 = 3$, $3 = 1 + 2$, $3 = 2 + 1 = 3 = 1 + 1 + 1$.

Inasmuch as the stringing of the beads is a synthetic process, it will be necessary to begin with the synthetic reading. As the child proceeds with the work of string-

ing the beads, it says in accordance with the teacher's dictation or with the number formula indicated on the blackboard: "One orange (ball), one green (ball), one violet (ball)—three balls; one red (cyl.), two green (cyl.)—three cylinders; two blue (cubes), one yellow (cube)—three cubes; three violet balls," etc.

When the work is done, it surveys the string of beads, and is helped to read analytically, from left to right or vice versa: "Three balls—one orange, one green, one violet; three cylinders—one red, two green; three cubes—two blue, one yellow; three violet balls," etc.

Similar remarks apply to the "tables" for addition and subtraction, as well as to those for multiplication and division. The bead exercise that answers for addition is equally serviceable for subtraction; and the exercise that teaches multiplication is equally useful for division, as will appear directly.

II. SYNTHESIS AND ANALYSIS OF 2 TO 10.

1. $\boxed{r} \boxed{g} \circ \circ \boxed{g} \boxed{r} \vee \boxed{r} \boxed{g} \circ \circ \boxed{g} \boxed{r}$ &c. (1+1) (2) (1+1) &c.

2. $\circ \vee \circ \boxed{b} \boxed{g} \boxed{r} \circ \circ \boxed{r} \boxed{g} \boxed{b} \circ \vee \circ$ $\begin{matrix} (1+1) & (1+1) & (1+1) & (2) \\ \&c. & \text{or } 2=1+1 & \&c. \end{matrix}$

3. $\left\{ \begin{array}{l} \boxed{v \ b \ g \ y \ o \ o \ r \ r \ v \ y \ y \ y \ r} \\ \boxed{y \ y \ y \ v \ r \ r \ o \ o \ y \ g \ b \ v} \end{array} \right\} \begin{array}{l} (1+1+1) \ (1+2) \ (2+1) \\ (3)-(3) \ (1+2) \ \text{or } 3 \\ = 1+1+1, \ 3 = 1+ \\ 2, \ 3 = 2+1, \ \&c. \end{array}$

4. $\left\{ \begin{array}{l} \boxed{r \ o \ y \ g \ r \ y \ y \ y \ b \ b \ o \ o \ v \ v \ v \ v} \\ \boxed{o \ o \ b \ b \ y \ y \ y \ r \ g \ y \ o \ r} \end{array} \right\} \begin{array}{l} (1+1+1 \\ +1)(1+3) \\ (2+2) \ (4) \\ (2+2) \\ \&c.; \text{-or,} \end{array}$
 $4 = 4 \ (1), \ 4 = 1+3, \ 4 = 2 \ (2), \ 4 = 1 \ (4), \ \&c.$

5. $\left\{ \begin{array}{l} \boxed{r \ o \ y \ g \ b \ v \ v \ b \ g \ y \ y \ y \ o \ o \ r \ r \ b \ b \ b \ y} \\ \boxed{v \ v \ v \ v \ y \ b \ b \ b \ r \ r \ o \ o \ y \ y \ y \ g \ b \ v \ v \ b} \\ \boxed{g \ y \ o \ r} \end{array} \right\} . \ 4 \ (1) \ (1+2+1) \ (1+3) \ (2+2) \ (3+1) \ (4) \ \&c.$

6. $\left\{ \begin{array}{l} \boxed{v \ b \ g \ y \ o \ r \ g \ g \ g \ g \ b \ b \ y \ y \ y \ v \ v \ v \ v \ v} \\ \boxed{y \ y \ y \ b \ b} \end{array} \right\} \ \&c. \ 5 \ (1) \ (1+4) \ (2+3) \ (5) \ (3+2) \ \&c.$

7. $\left\{ \begin{array}{l} \boxed{r \ b \ y \ b \ r \ g \ o \ o \ v \ v \ r \ g \ g \ g \ r \ y \ b \ b \ b \ b} \\ \boxed{o \ o \ g \ g \ g \ r \ r \ r \ r \ r \ g \ g \ g \ o \ o} \end{array} \right\} \ \&c. \ 5 \ (1) \ (1+2 \\ +2) \ (1+3+1) \ (1+4) \ (2+3) \ (5) \ (3+2) \ (4+1) \ \&c.$

8. $\left\{ \begin{array}{l} \boxed{r \ o \ y \ g \ b \ v \ r \ r \ o \ o \ y \ y \ g \ g \ g \ b \ b \ b} \\ \boxed{v \ v \ v \ v \ v \ v \ b \ b \ b \ g \ g \ g \ y \ y \ o \ o \ r \ r} \\ \boxed{v \ b \ g \ y \ o \ r} \end{array} \right\} . \ 6 \ (1), \ 3 \ (2), \ 2 \ (3), \ (6), \ 2 \ (3), \ 3 \ (2), \ 6 \ (1)$

9. $\left\{ \begin{array}{l} \boxed{y \ v \ v \ v \ v \ v \ o \ o \ b \ b \ b \ b \ r \ r \ r \ g \ g \ g} \\ \boxed{o \ o \ o \ o \ o \ o \ g \ g \ g \ r \ r \ r \ b \ b \ b \ b \ o \ o} \\ \boxed{v \ v \ v \ v \ v \ y} \end{array} \right\} . \ (1+5) \ (2+4) \ (3+3) \ (6) \ (3+3) \ (4+2) \ (5+1)$

10. $\left\{ \begin{array}{l} \boxed{v \ v \ v \ b \ b \ b \ b} \ \textcircled{g \ g \ y \ y \ y \ y \ y} \ \textcircled{o} \ \textcircled{r} \ \textcircled{r} \ \textcircled{r} \ \textcircled{r} \ \textcircled{r} \\ \textcircled{y \ y \ y \ y} \ \textcircled{y \ y \ y} \ \textcircled{r \ r \ r \ r \ r \ r} \ \textcircled{o} \ \textcircled{y \ y \ y \ y \ y} \ \textcircled{g \ g} \\ \boxed{b \ b \ b \ b \ v \ v \ v} \ . \ (3+4) \ (2+5) \ (1+6) \ (7) \ (6+1) \ (5+2) \ (4+3) \end{array} \right.$

11. $\left\{ \begin{array}{l} \textcircled{g \ y \ o \ r \ o \ y \ r} \ \textcircled{v \ v \ o \ o} \ \textcircled{g \ g \ r} \ \boxed{y \ y \ y \ b \ b \ b \ r} \\ \textcircled{v \ v \ v \ v} \ \textcircled{v \ v \ v} \ \&c. \ 7 \ (1), \ 3 \ (2)+1, \ 2 \ (3)+1, \ 7, \ \&c. \end{array} \right.$

12. $\left\{ \begin{array}{l} \boxed{y \ y \ y \ y \ v \ v \ v \ v} \ \textcircled{o \ o \ o} \ \textcircled{b \ b \ b \ b \ b} \\ \textcircled{g \ g \ r \ r \ r \ r \ r} \ \textcircled{r} \ \boxed{y \ b \ b \ b \ b \ b \ b \ b} \\ \textcircled{r \ r \ r \ r \ r \ r \ r} \ \textcircled{r} \ \textcircled{b \ b \ b \ b \ b \ b \ b} \ \textcircled{y} \ \&c. \ (4+4), \ (3+5) \\ \ (2+6) \ (1+7) \ (8) \ (7+1) \ \&c. \end{array} \right.$

13. $\left\{ \begin{array}{l} \textcircled{r \ r \ r \ r} \ \textcircled{o \ o \ o \ o} \ \textcircled{y \ y} \ \textcircled{g \ g} \ \textcircled{b \ b} \ \textcircled{v \ v} \\ \textcircled{r \ o \ y \ g \ b \ v \ r} \ \textcircled{y} \ \textcircled{b \ b \ b \ b \ b \ b \ b} \\ \textcircled{y \ r \ v \ b \ g \ y \ o \ r} \ \&c. \ 2 \ (4), \ 4 \ (2), \ 8 \ (1), \ 8, \ 8 \ (1) \ \&c. \end{array} \right.$

14. $\left\{ \begin{array}{l} \textcircled{o \ o \ o} \ \textcircled{g \ g \ g} \ \textcircled{v \ v \ v} \ \textcircled{r \ y \ b \ r \ y \ b \ r \ y \ b} \\ \boxed{o \ o \ o \ o} \ \textcircled{o \ o \ o \ o} \ \&c. \ 3 \ (3), \ 9 \ (1), \ 9, \ \&c. \end{array} \right.$

15. $\left\{ \begin{array}{l} \textcircled{r \ r \ r \ r} \ \textcircled{r \ g \ g \ g \ g} \ \textcircled{v \ v} \ \textcircled{o \ o} \ \textcircled{g \ g} \ \textcircled{o \ o} \ \textcircled{v \ v} \\ \textcircled{r \ y \ r \ y \ r \ y \ r \ y \ r \ y} \ \textcircled{b \ b \ b \ b \ b \ b \ b \ b \ b} \\ \boxed{y \ r \ y \ r \ y \ r \ y \ r \ y \ r} \ \&c. \ 2 \ (5), \ 5 \ (2), \ 10 \ (1), \ 10, \ 10 \ (1) \ \&c. \end{array} \right.$

All these exercises may be read analytically as well as synthetically. Thus Exer-

cise 10 may be read, $3 + 4 = 7$, $2 + 5 = 7$, $1 + 6 = 7$, $7 = 7$, $6 + 1 = 7$, $5 + 2 = 7$, $4 + 3 = 7$; or, analytically, $7 = 3 + 4$, $7 = 2 + 5$, $7 = 1 + 6$, $7 = 7$, $7 = 6 + 1$, $7 = 5 + 2$, $7 = 4 + 3$. This is indicated above in Ex. 2, 3, and 4.

After what has been said on the subject in Chapter V., the teacher will find it easy to discover the suggestions, indicated in the diagrams, concerning waves of color and form, as well as the devices for marking the highest points of the waves and for separating one wave from another. Thus, Ex. 1 indicates two waves separated by a purple cylinder; and in Ex. 3 the highest point of the wave is marked by a red ball. In most cases only one wave is indicated, as in Ex. 2, 3, 4, and 5. In some cases, only a part of the wave is shown; the teacher will find it easy to supply the missing "descending" portion, *e. g.* in Ex. 6, 7, and others. In all cases, pupils may string as many waves as time and beads permit.

It will be noticed that, in exercises with numbers above 5, the number itself which marks the highest point of the wave in beads of the same *color* is broken up into a

shadowy *form* wave. This is done in order to enable the child to recognize the number more readily and *without counting by ones*. Thus, in Ex. 8, the six purple beads in the middle are two *cylinders* with two *cubes* on each side. These "three twos" indicated by the differences of form, facilitate the reading of the "six purple beads." This device should be dropped very cautiously, inasmuch as children find it quite difficult to grasp at sight numbers higher than five.

III. ADDITION AND SUBTRACTION TABLES.

1. $\left\{ \begin{array}{l} \boxed{r \ o \ r \ r \ o \ r \ r \ r \ o \ r \ r \ r \ r \ o} \\ \boxed{r \ r \ r \ r \ r \ o} \ \&c. \begin{cases} (1+1) \ (2+1) \ (3+1) \ (4+1) \ (5+1) \ \&c. \\ (2-1) \ (3-1) \ (4-1) \ (5-1) \ (6-1) \ \&c. \end{cases} \end{array} \right.$
2. $\left\{ \begin{array}{l} \boxed{g \ b \ b \ g \ g \ b \ b \ g \ g \ g \ b \ b \ g \ g \ g \ g \ b \ b} \ \&c. (1+2) \\ (2+2) \ (3+2) \ (4+2) \ \&c. - (3-2) \ (4-2) \ (5-2) \ (6-2) \ \&c. \end{array} \right.$
3. $\left\{ \begin{array}{l} \boxed{y \ o \ o \ o \ y \ y \ o \ o \ o \ y \ y \ y \ o \ o \ o} \\ \boxed{y \ y \ y \ y \ o \ o \ o} \ \&c. \ (1+3) \ (2+3) \ (3+3) \ \&c. - (4-3) \ (5-3) \\ (6-3) \ (7-3) \ \&c. \end{array} \right.$
4. $\left\{ \begin{array}{l} \boxed{b \ v \ v \ b \ b \ b \ v \ v \ b \ b \ b \ b \ b \ v \ v} \ \&c. \ (1+2) \ (3+2) \\ (5+2) \ \&c. - (3-2) \ (5-2) \ (7-2). \end{array} \right.$
5. $\left\{ \begin{array}{l} \boxed{r \ r \ v \ v \ v \ r \ r \ r \ r \ v \ v \ v \ r \ r \ r \ r \ r \ r \ v \ v \ v} \\ \&c. \ (2+3) \ (4+3) \ (6+3) \ \&c. - (5-3) \ (7-3) \ (9-3) \ \&c. \end{array} \right.$

$$6. \left\{ \begin{array}{l} \overbrace{(b \ b \ g \ b \ b \ g \ g \ b \ b \ g \ g \ g \ b \ b \ g \ g \ g \ g)} \text{ \&c.} (2+1) \\ (2+2) (2+3) (2+4) \text{ \&c.} - (6-2) (5-2) (4-2) (3-2). \end{array} \right.$$

$$7. \left\{ \begin{array}{l} \overbrace{(o \ o \ o \ y \ o \ o \ o \ y \ y \ y \ o \ o \ o \ y \ y \ y \ y \ y)} \text{ \&c.} (3+1) \\ (3+3) (3+5) \text{ \&c.} - (8-3) (6-3) (4-3). \end{array} \right.$$

For the addition and subtraction exercises, it is not desirable to reverse the order of the exercises, or to string the beads in waves of color and form. Each repetition of an exercise should be in the same order with the first, ascending or descending; only in the colors of the beads a change should be made. Thus, in a repetition of Ex. 1, the beads would follow each other in the same order and arrangement [(1 + 1) (2 + 1) (3 + 1), etc.]; but for red and orange two other adjacent colors, *e. g.*, blue and violet, would be used. Then, for a third series, yellow and green may be chosen.

It will be noticed that in all exercises sharp color contrasts between the terms of the same sum or series of sums (or differences) are avoided. This facilitates, on the one hand, the formation of mental sum images, and minuend images. For similar reasons, the same color contrasts are re-

tained for a given series of sums or differences.

It will be easy for the teacher to discover the principles that underlie the construction of Ex. 1, 2, and 3; 4 and 5, and 6 and 7, respectively; and to construct whatever additional similar exercises she may desire for the same or other numbers. Still other tables in which the sum (respectively the minuend) remains the same throughout the series are suggested by Ex. 9, 10, and 12, on pp. 35 and 36.

IV. MULTIPLICATION AND DIVISION TABLES.

1.

| | | | | | | | | | | | | | | | | | | | |
|---|---|---|---|---|---|---|---|---|---|---|---|---|---|---|---|---|---|---|---|
| r | o | y | y | g | g | b | b | b | v | v | v | r | r | r | r | o | o | o | o |
|---|---|---|---|---|---|---|---|---|---|---|---|---|---|---|---|---|---|---|---|

,
 &c. 2 (1), 2 (2), 2 (3), 2 (4) &c.—

2.

| | | | | | | | | | | | | | | | | | |
|---|---|---|---|---|---|---|---|---|---|---|---|---|---|---|---|---|---|
| v | b | g | v | v | b | b | g | g | v | v | v | b | b | b | g | g | g |
|---|---|---|---|---|---|---|---|---|---|---|---|---|---|---|---|---|---|

, &c. 3 (1),
 3 (2), 3 (3), 3 (4) &c.

3.

| | | | | | | | | | | | |
|---|---|---|---|---|---|---|---|---|---|---|---|
| r | o | y | g | r | r | o | o | y | y | g | g |
|---|---|---|---|---|---|---|---|---|---|---|---|

| | | | | | | | | | | | |
|---|---|---|---|---|---|---|---|---|---|---|---|
| r | r | r | o | o | o | y | y | y | g | g | g |
|---|---|---|---|---|---|---|---|---|---|---|---|

, &c. 4 (1), 4 (2), 4 (3) &c.

4.

| | | | | | | | | | | | | | | | | | | | |
|---|---|---|---|---|---|---|---|---|---|---|---|---|---|---|---|---|---|---|---|
| v | v | b | b | g | g | y | y | o | o | r | r | v | v | b | b | g | g | y | y |
|---|---|---|---|---|---|---|---|---|---|---|---|---|---|---|---|---|---|---|---|

,
 &c. 1 (2), 2 (2), 3 (2), 4 (2) &c.

5.

| | | | | | | | | | | | | | | | | | |
|---|---|---|---|---|---|---|---|---|---|---|---|---|---|---|---|---|---|
| v | v | v | r | r | r | o | o | o | g | g | g | b | b | b | v | v | v |
|---|---|---|---|---|---|---|---|---|---|---|---|---|---|---|---|---|---|

| | | | | | | | | | | | |
|---|---|---|---|---|---|---|---|---|---|---|---|
| r | r | r | o | o | o | y | y | y | g | g | g |
|---|---|---|---|---|---|---|---|---|---|---|---|

, &c.—1 (3), 2 (3), 3 (3) &c.

$$6. \left\{ \begin{array}{l} \boxed{r r r b b b} \bigcirc o o g g o o r g o o g r \\ \bigcirc o o g g o o \boxed{b b b r r r} \end{array} \right., 2 (3), 3 (2), 6 (1), 2 (3)$$

In Ex. 1, 2, and 3 the multiplier is constant; in Ex. 4 and 5 the multiplicand is constant; in Ex. 6 the product is constant. Additional suggestions for the last case may be found in Ex. 13, 14, and 15, on page 36.

The exercises may be dictated or indicated on the blackboard, read or reduced to slate-work from the strings for multiplication, division, or part-taking. Thus, Ex. 1 may be dictated or indicated on the blackboard.

| (a) for multiplication. | (b) for division. | (c) for part-taking. |
|-------------------------|-------------------|--|
| 2 (1) | $2 \div 1^*$ | $\frac{2}{2}$ (2) or $\frac{1}{1}$ (2) |
| 2 (2) | $4 \div 2$ | $\frac{2}{2}$ (4) $\frac{1}{1}$ (4) |
| 2 (3) | $6 \div 3$ | $\frac{2}{2}$ (6) $\frac{1}{1}$ (6) |
| 2 (4) | $8 \div 4$ | $\frac{2}{2}$ (8) $\frac{1}{1}$ (8) |
| etc. | etc. | etc. etc. |

The child may read the answers from the string, for multiplication: Two ones are two, two twos are four, etc.; for division: There are two ones in two, there are two twos in four, etc.; for part-taking: Two

* This is read by the pupil from right to left: "How many ones in two? how many twos in four," etc.

halves of two are two ones, two halves of four are two twos; or one half of two is one, one half of four is two, etc.—It may reduce the results of its stringing to slate-work as follows:

| (a) for multiplication ; | (b) for division ; | (c) for part-taking. |
|--------------------------|--------------------|--|
| 2 (1)= 2 | 2÷1=2 (1) | $\frac{2}{2}$ (2)=2 (1) or $\frac{1}{2}$ (2)=1 |
| 2 (2)= 4 | 4÷2=2 (2) | $\frac{2}{2}$ (4)=2 (2) $\frac{1}{2}$ (4)=2 |
| 2 (3)= 6 | 6÷3=2 (3) | $\frac{2}{2}$ (6)=2 (3) $\frac{1}{2}$ (6)=3 |
| 2 (4)= 8 | 8÷4=2 (4) | $\frac{2}{2}$ (8)=2 (4) $\frac{1}{2}$ (8)=4 |
| 2 (5)=10 | 10÷5=2 (5) | $\frac{2}{2}$ (10)=2 (5) $\frac{1}{2}$ (10)=5 |
| etc. | etc. | etc. etc. |

The following additional dictations are suggested for the benefit of the less experienced teachers:

| (a) for multiplication ; | (b) for division ; | (c) for part-taking. |
|--------------------------|--------------------|---|
| 1) 3 (1) 2) 4 (1) | 1) 3÷1 2) 4÷1 | 1) $\frac{3}{3}$ (3) 2) $\frac{4}{4}$ (4) |
| 3 (2) 4 (2) | 6÷2 4÷2 | $\frac{3}{3}$ (6) $\frac{4}{4}$ (8) |
| 3 (3) 4 (3) | 9÷3 4÷3 | $\frac{3}{3}$ (9) $\frac{4}{4}$ (12) |
| 3 (4) | 12÷4 4÷4 | $\frac{3}{3}$ (12) |
| 3) 1 (2) 4) 1 (3) | 3) 2÷2 4) 3÷3 | 3) $\frac{2}{2}$ (4) 4) $\frac{2}{2}$ (6) |
| 2 (2) 2 (3) | 4÷2 6÷3 | $\frac{2}{2}$ (6) $\frac{2}{2}$ (9) |
| 3 (2) 3 (3) | 6÷2 9÷3 | $\frac{4}{4}$ (8) $\frac{4}{4}$ (12) |
| 4 (2) 3 (4) | 8÷2 12÷3 | |
| 5 (2) | 10÷2 | |
| 5) 1 (4) 6) 1 (5) | 5) 4÷4 6) 5÷5 | 5) $\frac{4}{4}$ (8) 6) $\frac{5}{5}$ (6) |
| 2 (4) 2 (5) | 8÷4 10÷5 | $\frac{4}{4}$ (8) $\frac{5}{5}$ (6) |
| 3 (4) 3 (5) | 12÷4 15÷5 | $\frac{4}{4}$ (8) $\frac{5}{5}$ (6) |

The child would read the answers from the string, as indicated on page 41. In slate-work, the answers would make neat tables, as follows:

(a) for multiplication;

(b) for division;

- | | | | |
|-------------|-------------|--------------|--------------|
| 1) 3 (1)= 3 | 2) 4 (1)= 4 | 1) 3÷1=3 (1) | 2) 4÷1=4 (4) |
| 3 (2)= 6 | 4 (2)= 8 | 6÷2=3 (2) | 4÷2=2 (2) |
| 3 (3)= 9 | 4 (3)=12 | 9÷3=3 (3) | 4÷3=1 (3)+1 |
| 3 (4)=12 | . | 12÷4=3 (4) | 4÷4=1 (4) |
| 3) 1 (2)= 2 | 4) 1 (3)= 3 | 3) 2+2=1 (2) | 4) 3÷3=1 (3) |
| 2 (2)= 4 | 2 (3)= 6 | 4÷2=2 (2) | 6÷3=2 (3) |
| 3 (2)= 6 | 3 (3)= 9 | 6÷2=3 (2) | 9÷3=3 (3) |
| 4 (2)= 8 | 3 (4)=12 | 8÷2=4 (2) | 12÷3=4 (3) |
| 5 (2)=10 | | 10÷2=5 (2) | |
| 5) 1 (4)= 4 | 6) 1 (5)= 5 | 5) 4÷4=1 (4) | 6) 5÷5=1 (5) |
| 2 (4)= 8 | 2 (5)=10 | 8÷4=2 (4) | 10÷5=2 (5) |
| 3 (4)=12 | 3 (5)=15 | 12÷4=3 (4) | 15÷5=3 (5) |

(c) for part-taking.

- | | |
|----------------------------|----------------------------|
| 1) $\frac{3}{8}$ (3)=3 (1) | 2) $\frac{4}{4}$ (4)=4 (1) |
| $\frac{3}{8}$ (6)=3 (2) | $\frac{4}{4}$ (8)=4 (2) |
| $\frac{3}{8}$ (9)=3 (3) | $\frac{4}{4}$ (12)=4 (3) |
| $\frac{3}{8}$ (12)=3 (4) | |
| 3) $\frac{2}{8}$ (4)=2 (2) | 4) $\frac{2}{8}$ (6)=2 (3) |
| $\frac{2}{8}$ (6)=3 (2) | $\frac{2}{8}$ (9)=3 (3) |
| $\frac{4}{4}$ (8)=4 (2) | $\frac{4}{4}$ (12)=4 (3) |
| 5) $\frac{2}{8}$ (8)=2 (4) | 6) $\frac{2}{8}$ (6)=2 (3) |
| $\frac{4}{4}$ (8)=4 (2) | $\frac{3}{8}$ (6)=3 (2) |
| $\frac{8}{8}$ (8)=8 (1) | $\frac{6}{8}$ (6)=6 (1) |

It will rarely be found advisable to go beyond ten in these exercises. Even the twelves and the fifteens in the above suggestions are of doubtful propriety.

Work of this character may be done with great profit during the first (average) school-year, and need not be wholly abandoned during the second school-year.

CHAPTER VII.

A NUMERAL FRAME FOR EACH PUPIL.

IN a measure, the exercises suggested in the last two chapters satisfy this demand of "a numeral frame for each pupil." Yet, while they are unsurpassable for the formation of number *perceptions*, more flexible material is needed for calling up more promptly and in quicker succession images of these perceptions in the mind, thus aiding in the formation of mobile *number conceptions*, and leading the pupil from the mere desire for playing with numbers of pretty things to a real interest in number as such.

For this purpose I have chosen the balls. They represent the most mobile of the three bead forms and are least weighted with form features. These again are gradually freed from disturbing color contrasts by giving the pupil only two colors to work with, separating the ten beads of the

first series of exercises into two fives, and the twenty beads of the second series into two tens. These beads are fixed on the child's desk in a mobile arrangement, constantly ready for immediate use (Fig. 1). Near the back of the desk two eyelet screws

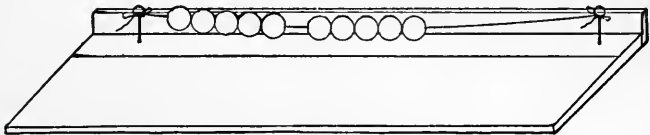

Fig. 1

are screwed into the desk. To one of these a shoe-string is tied. The beads are then strung by the pupil, and the free end of the string tied with a bow-knot to the second screw. The entire outfit costs five cents.

In all arithmetical exercises, this contrivance is at hand to furnish the child with the sure foundation of actual number perceptions, to give him opportunities for translating his number-thoughts into things, and to shield him against the dangers of mere verbalism. With its help the pupil follows dictations, solves problems indicated on the board or in the book, studies the relationships of given numbers, prepares arithmet-

ical tables, etc. A few typical exercises will illustrate my meaning. The exercises are selected from the first series for ten beads or two fives.

(1) The teacher is ready to dictate this exercise: $2 + 3 - 4 + 3 + 2 - 1 + 3 + 2$. The children sit ready to give the answers, first on the strings of beads, and then orally, as follows (the teacher's words are quoted): "Place all beads on the left. With the right hand move to the right: Two beads."—Two beads.—"Add three."—Five (beads).—"Subtract four."—One (bead).—"Add three."—Four (beads).—"Add two."—Six (beads).—"Subtract one."—Five (beads).—"Add three."—Eight (beads).—"Add two."—Ten (beads).—The same exercise may then be repeated with the left hand, moving the beads to the left. Indeed, in the light of the beneficial influence of ambidextrous work upon mental growth, I am tempted to say the exercise should be so repeated.

(2) The teacher has decided upon this dictation: $1 + 3, 2 + 2, 1 + 4, 2 + 3, 4 - 3, 5 - 3, 3 + 1, 4 + 1, 5 - 1, 4 - 2, 3 + 2, 5 - 2$. The children sit ready as above. The teacher begins: "With the left hand, all beads to

the left.—With the right hand one bead, with the left hand three beads; move all to the right.”—Children, as they move the beads: One (bead) and three (beads) are four (beads).—“All beads to the left.”—(It should be understood that this is carried out with the left hand).—“(With the right hand) two beads, (with the left hand) two beads; (all to the right).”—Two (beads) and two (beads) are four (beads).—“Beads to the left.”—“One (bead) and four (beads).”—One and four are five, etc. Expressions in parentheses may be gradually dropped, in order to give more and more prominence to the pure number forms. The teacher, however, should frequently return to them.

(3) The teacher has placed on the black-board, for silent work, one or more of the following exercises:

| (1) | (2) | (3) | (4) | (5) | (6) |
|-----|------|-------|------|--------------|----------|
| 4 | | (1) 4 | | (4) 5+2 = | 4+ =6 |
| 5 | | (2) 6 | | (2) 6-3 = | 7- =3 |
| 3 | | (3) 5 | | (6) 3 (3) = | 2 () =6 |
| 6 | +2 2 | (4) 3 | +2 ½ | (8) 6+2 = | 8+4 = |
| 2 | | (5) 2 | | (10) ½ (6) = | ¼ () =2 |
| 7 | | (3) 8 | | (6) ⅔ (6) = | 5+ =8 |
| 1 | | (1) 7 | | (2) 6+3 = | 6+ 2= |
| 8 | | (4) 9 | | (4) 5+4 = | ½ () =4 |

The children either study these problems for oral work, sitting squarely before the beads and working with both hands as occasion may require; or they set down on their slates the problems and solutions, working the beads with the left hand, and writing with the right hand. Thus:

| (1) | (2) | (3) | (4) | (5) | (6) |
|---------|-----------|--------------|---------------------|--------------------|--------------------|
| $4+2=6$ | $2(1)=2$ | $4+2=2(2)$ | $\frac{1}{2}(4)=2$ | $5+2=7$ | $4+2=6$ |
| $4-2=2$ | $2(2)=4$ | $6+2=3(2)$ | $\frac{1}{2}(2)=1$ | $6-3=3$ | $7-4=3$ |
| $5+2=7$ | $2(3)=6$ | $5+2=2(2)+1$ | $\frac{1}{2}(6)=3$ | $3(3)=9$ | $2(3)=6$ |
| $5-2=3$ | $2(4)=8$ | $3+2=1(2)+1$ | $\frac{1}{2}(8)=4$ | $6+2=3(2)$ | $8+4=2(4)$ |
| $6+2=8$ | $2(5)=10$ | $2+2=1(2)$ | $\frac{1}{2}(10)=5$ | $\frac{1}{2}(6)=2$ | $\frac{1}{2}(8)=2$ |

When the children have satisfactorily mastered the first series of exercises within the limits of one to ten or two fives, they may proceed to the second series, using twenty beads or two tens of different colors. These give very much greater latitude for exercises in multiplication, division, and part-taking.

The difference in color in the two tens gives a marked advantage in the formation of clear notions of numbers between 10 and 20. With red and green beads eleven appears as one (green) and ten (red) beads; twelve, as two (green) and ten (red) beads;

thirteen (three-teen), as three (green) and ten (red) beads; fourteen, as four and ten; etc. If the pupil adds $8 + 6$, the result, four green and ten red balls, almost *says* fourteen to him. If he is to subtract $16 - 9$, he removes with little trouble the 6 (green) and 3 (red) balls as nine. This advantage is invaluable in the formation of distinct mental number images, in accordance with the current decimal system of notation.

I append a few series of typical exercises within the limits of 1 to 20. The reader should study them with the help of a string of beads or some suitable substitute, such as buttons or perforated beans, if he would fully appreciate the value of the device. The mode of treating them is indicated on pp. 48 and 49, Exercise 3.

| (1) | (2) | (3) | (4) | (5) | (6) |
|-------|------|--------|---------------|---------------------|-----|
| 8 | 1 + | (1) 12 | $\frac{1}{2}$ | $\frac{2}{3}(15) =$ | |
| 7 | 2 + | (2) 14 | $\frac{1}{3}$ | $16 \div 4 =$ | |
| 9 + 5 | 3 + | (3) 15 | $\frac{2}{3}$ | $9 + 8 =$ | |
| 6 | 4 + | (4) 18 | $\frac{1}{4}$ | (12) $17 - 8 =$ | |
| 12 | 11 = | (5) 13 | $\frac{3}{4}$ | $16 - 11 =$ | |
| 13 | 6 + | (6) 16 | $\frac{1}{6}$ | $6(3) =$ | |
| 18 | 7 + | 10 | $\frac{5}{6}$ | $17 \div 5 =$ | |
| 14 | 8 + | 20 | | | |
| 11 | 9 + | | | | |

| | | | |
|--|--|---|--|
| (7) | (8) | (9) | (10) |
| $3+$ $4+$ $5+$ $2()$ $3()$ $4()$ $6()$ | $11-$ $13-$ $4=$ $\frac{1}{2}()$ $\frac{1}{3}()$ $\frac{1}{4}()$ $\frac{1}{5}()$ | $6 + \frac{1}{2}(8) =$ $\frac{1}{3}(9) + 11 =$ $\frac{2}{3}(6) + 3(4) =$ $\frac{3}{4}(8) + 2(6) =$ $16 \div \frac{1}{2}(8) =$ | $6 + 7 + \frac{1}{2}(6) =$ $\frac{2}{3}(9) + 11 =$ $8 - \frac{1}{2}(15) + 4 =$ $4 + 4(4) - \frac{1}{4}(4) =$ $\frac{2}{3}(15) - \frac{3}{4}(12) =$ |

For the sake of avoiding misapprehension, I add the solutions of these exercises as they would appear on the children's slates:

| | | | |
|-----------|-----------|-----------|------------------------|
| (1) | (2) | (3) | (4) |
| $8+5=13$ | $11=1+10$ | $3(1)=3$ | $12 \div 6 = 2(6)$ |
| $7+5=12$ | $11=2+9$ | $3(2)=6$ | $14 \div 6 = 2(6) + 2$ |
| $9+5=14$ | $11=3+8$ | $3(3)=9$ | $15 \div 6 = 2(6) + 3$ |
| $6+5=11$ | $11=4+7$ | $3(4)=12$ | $18 \div 6 = 3(6)$ |
| $12+5=17$ | $11=5+6$ | $3(5)=15$ | $13 \div 6 = 2(6) + 1$ |
| $13+5=18$ | $11=6+5$ | $3(6)=18$ | $16 \div 6 = 2(6) + 4$ |
| $18+5=23$ | $11=7+4$ | | $10 \div 6 = 1(6) + 4$ |
| $14+5=19$ | $11=8+3$ | | $20 \div 6 = 3(6) + 2$ |
| $11+5=16$ | $11=9+2$ | | |

| | | | |
|---------------------------|------------------------|-----------|-----------------------|
| (5) | (6) | (7) | (8) |
| $\frac{1}{2}(12)=6$ | $\frac{2}{3}(15)=9$ | $12=3+9$ | $4=11-7$ |
| $\frac{1}{3}(12)=4$ | $16 \div 4 = 4(4)$ | $12=4+8$ | $4=13-9$ |
| $\frac{2}{3}(12)=2(4)=8$ | $9+8=17$ | $12=5+7$ | $4 = \frac{1}{2}(8)$ |
| $\frac{1}{4}(12)=3$ | $17-8=9$ | $12=2(6)$ | $4 = \frac{1}{3}(12)$ |
| $\frac{3}{4}(12)=3(3)=9$ | $16-11=5$ | $12=3(4)$ | $4 = \frac{1}{4}(16)$ |
| $\frac{1}{5}(12)=2$ | $6(3)=18$ | $12=4(3)$ | $4 = \frac{1}{5}(20)$ |
| $\frac{5}{6}(12)=5(2)=10$ | $17 \div 5 = 3(5) + 2$ | $12=6(2)$ | |

(9)

$$6 + \frac{1}{2} (8) = 10$$

$$\frac{1}{3} (9) + 11 = 14$$

$$\frac{2}{3} (6) + 3 (4) = 16$$

$$\frac{3}{4} (8) + 2 (6) = 18$$

$$16 \div \frac{1}{2} (8) = 4 (4)$$

(10)

$$6 + 7 + \frac{1}{2} (6) = 16$$

$$\frac{2}{3} (9) + 11 = 17$$



$$8 - \frac{1}{2} (15) + 4 = 9$$

$$4 + 4 (4) - \frac{1}{4} (4) = 19$$

$$\frac{3}{4} (15) - \frac{2}{4} (12) = 19$$

CHAPTER VIII.

THE COUNTING BLOCKS.

THESE are wooden one-inch blocks, derived from the third gift. They are used in three sizes: (1) whole cubes ($1 \times 1 \times 1$ in.) , (2) half cubes ($1 \times 1 \times \frac{1}{2}$ in.) , (3) quarter cubes ($1 \times \frac{1}{2} \times \frac{1}{2}$ in.) . For ordinary number exercises, especially in primary work, the *whole* cubes are most serviceable. They are more easily handled, and—because of their regular shape—fit in all positions, and do not divert the attention from number to form. The half and quarter cubes may be dispensed with altogether in number lessons; at any rate, they should not be used for this purpose until number images are well fixed by the exclusive use of whole cubes.

The number images furnished by these blocks mark an important advance in mental growth with reference to number. The balls of the “numeral frame” touch only

in one point, so that even beads of the same color retain their individuality prominently in the twos, threes, fours, fives, etc., of the lessons; the child readily recognizes in each two, three, four, five the constituent two, three, four, five ones. The counting blocks, on the other hand, coalesce quite perfectly on contact; an entire face of one coincides with an entire face of the neighbor, and the group of blocks forms a complete, unbroken whole. The modest division lines do not force their presence on the child's attention; still they are sufficiently clear to be readily distinguished, and to announce without difficulty the number of constituent ones in the new composite unit. Color, too, is removed so that the pupil's number conceptions are more and more freed from other phases of material existence that cling to *things*, and brought nearer to the pure forms of abstract *ideas*.

Before the teacher attempts to guide the work of the children, she should have experienced these effects of the new number forms upon her own mind. For this purpose she should provide herself with a

sufficient number of these blocks (a few cents will purchase one hundred), and carry out the suggestions of the following pages for herself, extending the exercises according to her own needs. In the work of the children the suggestions already made hold good. A limited number of typical lessons in counting, analysis and synthesis of numbers, and in the fundamental operations will, therefore, suffice to unlock the possibilities of this occupation. In the diagrams each square represents a cube.

I. COUNTING EXERCISES.

(1) The child receives ten or twelve blocks, and counts from one to ten, the successive number forms presenting the following or similar phases:

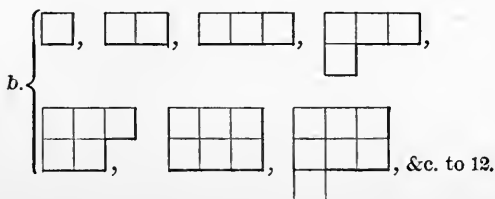
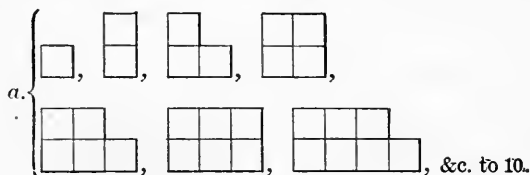

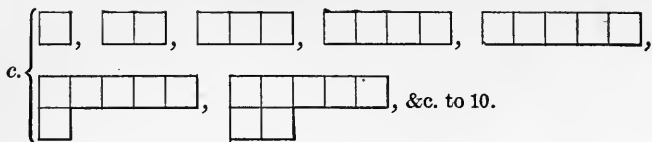

(2) The child receives from eighteen to twenty blocks, and counts by twos, threes, fours, or fives.

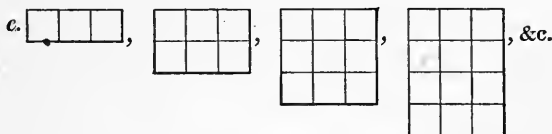
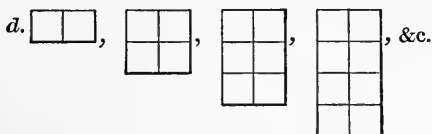

It will be noticed that the child thus secures a variety of mobile images of the various numbers. Thus in (a) 5 appears as $4 + 1$, in (b) as $3 + 2$, in (c) as 5 (1) or 1 (5); in (a) and (d) 6 appears as 3 (2), in (b) and (e) as 2 (3), in (c) as $5 + 1$, etc.

II. ANALYSIS AND SYNTHESIS OF NUMBERS.

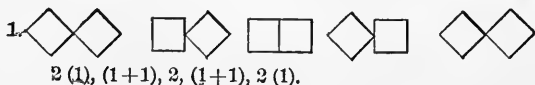

It will be seen that in Exercise (1), *posi-*

tion answers a purpose similar to that accomplished by color on pp. 34-36, with this difference, however, that the position of each cube is in the pupil's control. In the first form, both cubes are in the same slanting position, touching only corner to corner; they appear as two separate ones equal in position, or as 2 (1); in the second form they stand in different positions, touching again only in one point; they appear as two separate ones in different positions, or as (1 + 1); in the third position they have fully united, face to face, into a new composite unit; they appear as a two, 1 (2); the fourth and fifth forms are repetitions of the first and second in inverse order, forming the descending portion of a position wave similar to the color waves of Chapter V. and VI.

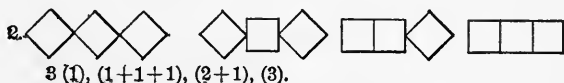

In this exercise, the number three is similarly treated. We have successively, three ones in the same position, yet clearly separated, one and one and one, two and one, and one three.

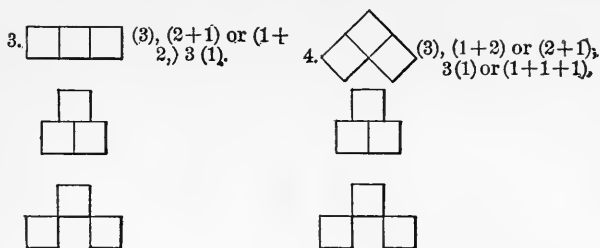

(Ex. 3 and 4 read from top to bottom or vice versa. This may be done with all these exercises.)

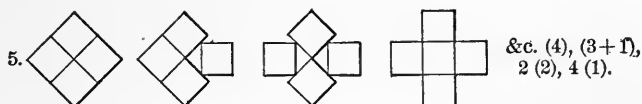

However, such exercises will prove quite cumbersome. They may be indulged for silent practice to a limited extent, but for class-instruction more efficient modes must be found. I have found it best, for this purpose, to begin on the analytic side of the work.

Thus for Ex. 6 the child receives four fours (16 blocks) arranged at equal distances from left to right. The task is to analyze them successively in accordance with the number indications:

(2 + 2) (1 + 3) (1 + 2 + 1) (4 (1)). The results

indicated in Ex. 6 may be reached by dictation or by independent study on the part of the more practical children.

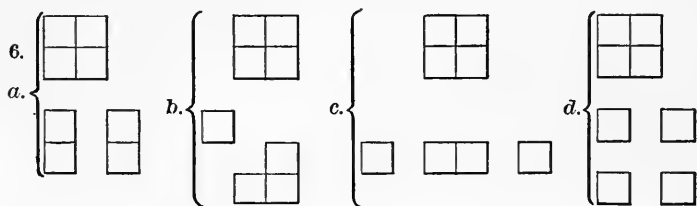

For Ex. 7 the children have received fifteen blocks each. The lesson is indicated on the blackboard:

$$1 + 4 = 5$$

$$2 + 3 = 5$$

$$2(2) + 1 = 5$$

Three sets of answers are indicated in the Exercise (7).

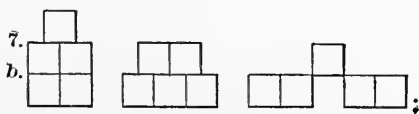
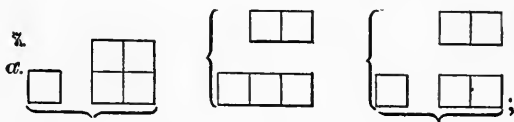

For Ex. 8 each child has received six blocks. The lesson has been indicated on the blackboard: $1+ = 6$; $2+ = 6$; $3+ = 6$; $6 \div 2 =$; $6 \div 3 =$. The child has solved the problems successively, and has recorded the solutions on the slate, in drawing and writing, and Ex. 8 shows one of the results:

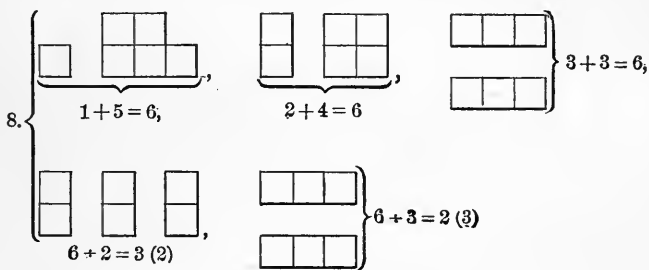

The great value of these blocks in factoring deserves special notice. For this purpose it is used to great advantage even in the fifth grade. Indeed, I have found children of still higher grades derive real benefit from an occasional return to these "things," when problems involving factoring had to be solved.

A few illustrations will make this clear. I have selected for this purpose the numbers 9, 10, 15, 12, 28, 36. For the number-forms the blocks are arranged in accord-

ance with our decimal system of notation, so that the number of tens and units may be readily distinguished; thus:

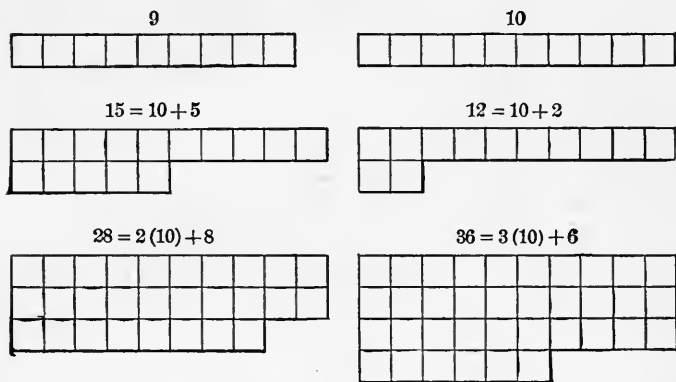

The pupils should then proceed in systematic order, testing the lowest factor first. Thus (9) would successively go through the following changes:

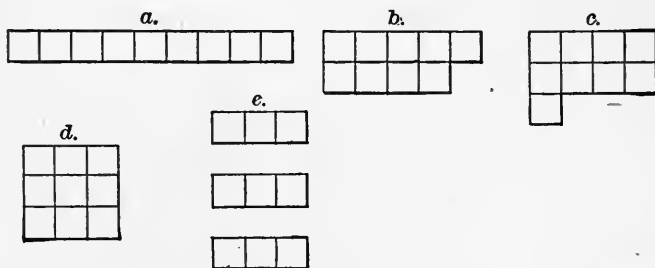

(10) and (15) are less refractory, yielding at once the forms $2(5)$ and $3(5)$, respectively:

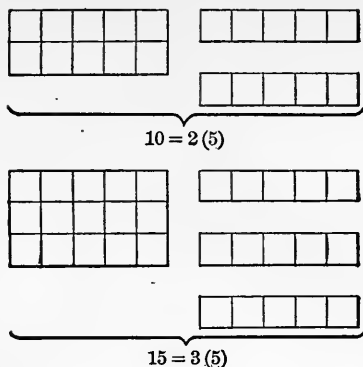

(12) may pass through a variety of successive transformations; in (a) $12 = 2(6) = 2 \times 2(3)$, in (b) $12 = 3(4) = 3 \times 2(2)$.

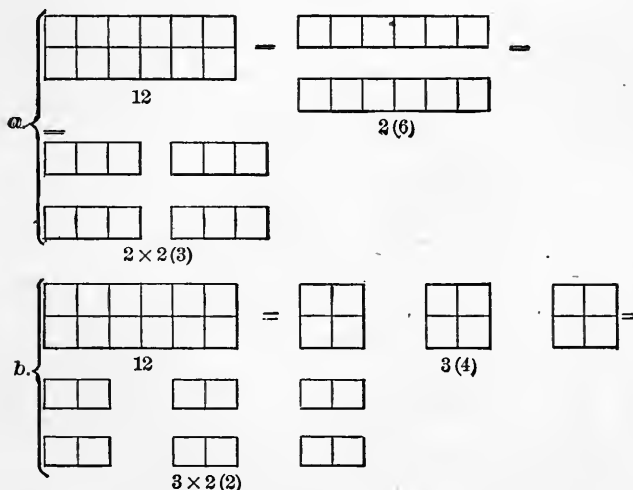

The following diagrams will sufficiently illustrate the factorings of (28) and (36).



In the illustration, twenty-eight is first resolved into 2 (10) and 2 (4) = 2 (14); then, in twice two sevens [$2 \times 2 (7)$].

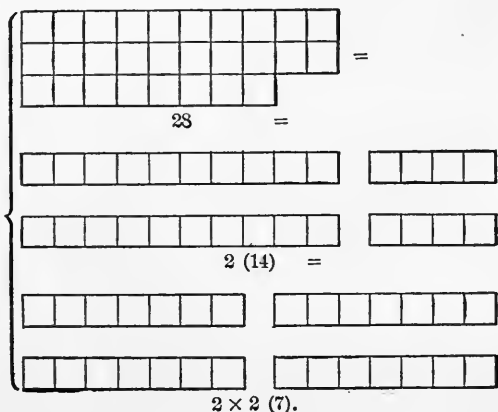

For thirty-six, two factorings are given on p. 64. In the first of these, bisection arranges the number in $2(10) + 2(5) + 2(3) = 2(18)$. These, by a second bisection, are readily grouped, each, in 2 (9), reducing 36 to $2 \times 2(9)$. Lastly, the trisection of the nines yields four sets of three threes, or $2 \times 2 \times 3(3)$.

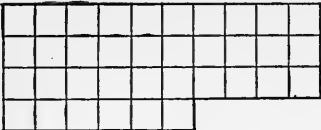
The same process is somewhat simplified in the second illustration of the reduction of thirty-six. We see successively two sets of two nines, $2 \times 2(9)$, and two sets of twice three sets of three, $2 \times 2 \times 3(3)$.

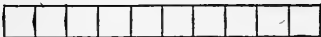



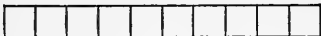
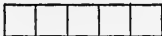

 =

$36 =$















 $2 (18) =$







 $2 \times 2 (9) =$









 &c.

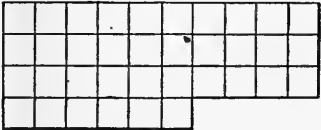







 $2 \times 2 \times 3 (3)$



or



 =

$36 =$



 $=$

 $2 \times 2 (9) = 2 \times 2 \times 3 (3).$

CHAPTER IX.

THE COUNTING BLOCKS. (Concluded.)

IN the use of the blocks for the fundamental operations—addition, subtraction, multiplication, division, and part-taking—the number-forms should be constructed in accordance with our decimal system of notation. Sixteen should appear clearly as one ten and one six; twenty-six as two tens and one six, etc. I have found it most convenient for this purpose to lay under each other as many tens (rows of ten blocks) as the number indicates, and the number of units under these. (See p. 61, where the number-forms of 9, 10, 15, 12, 28, and 36 are shown.)

In the solutions of problems it is best to dispose first of the tens of the number to be added or subtracted. Thus, if 27 is to be added, add first the 20 and then the 7; if 39 is to be subtracted, subtract first the 30 and then the 9; if 4 (26) is the prob-

lem, find 4 (20) and 4 (6), etc. This is in strict accordance with the number-names above 20; language says: Add *twenty-seven*, subtract *thirty-nine*, find the value of four *twenty-sixes*, etc. Besides this mode of procedure by removing the bulkiest portion of the task first, facilitates mental processes, and enables the pupils to ride safe between the Scylla of verbalism and the Charybdis of slavish subjection to slate-work.

In the following pages I present the successive number-forms as they occur in the solutions of a number of problems, illustrating the use of the blocks in the various fundamental operations. To these I have added a few examples of involution in connection with the finding of areas and volumes.

I. ADDITION:

TYPICAL PROBLEMS:

- | | | |
|-------------|--------------|------------|
| 1. $8+5=$ | 3. $14+5=$ | 5. $14+7=$ |
| 2. $9+6=$ | 4. $11+7=$ | 6. $19+5=$ |
| 7. $24+15=$ | 9. $29+23=$ | |
| 8. $26+14=$ | 10. $26+27=$ | |

SPECIMEN SOLUTIONS:

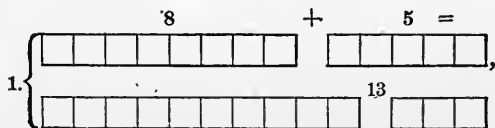

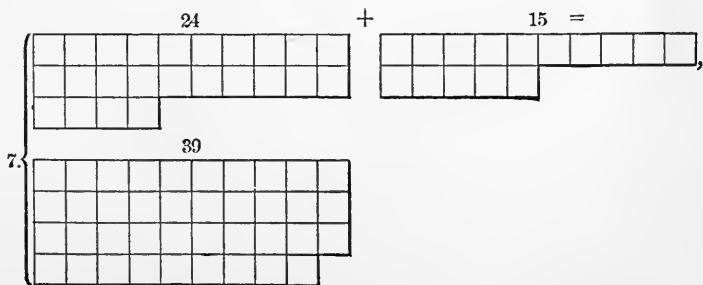
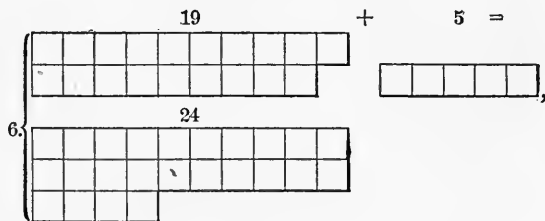
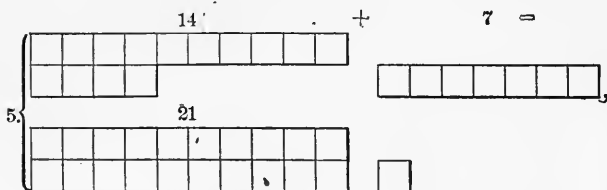
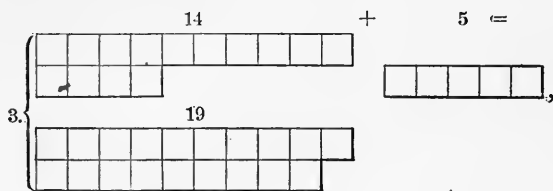
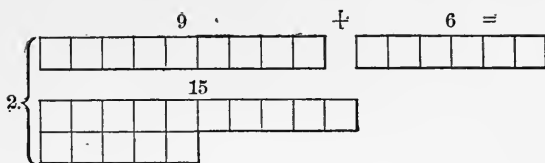

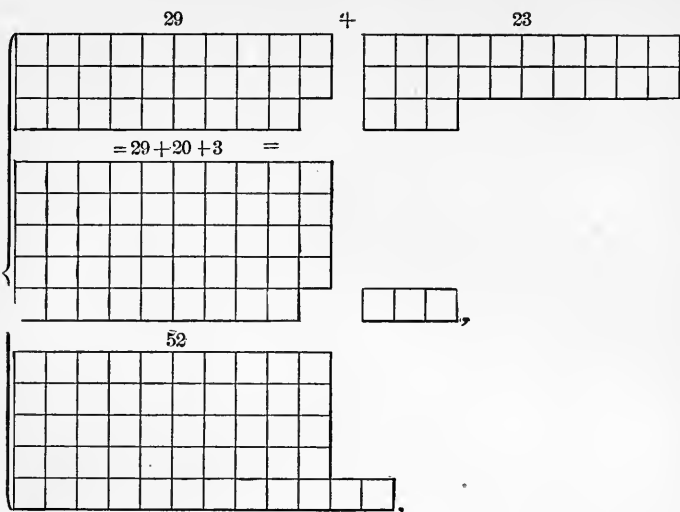

II. SUBTRACTION ;

TYPICAL PROBLEMS :

1. $16 - 4 =$

3. $28 - 12 =$

5. $58 - 34 =$

2. $12 - 7 =$

4. $32 - 26 =$

6. $51 - 29 =$

SPECIMEN SOLUTIONS :

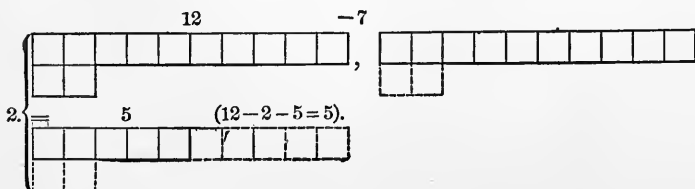
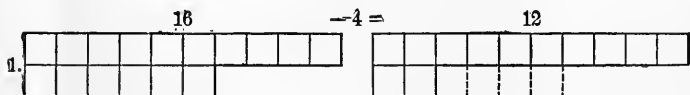

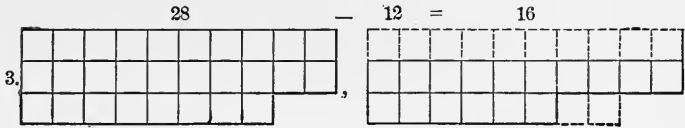

$(28 - 10 - 2 = 16)$

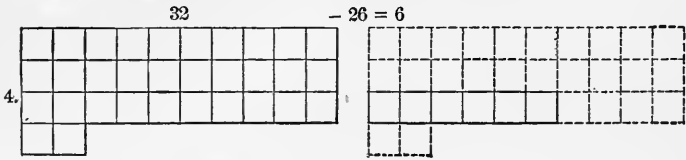

$32 - 20 - 2 - 4 = 6.$

III. MULTIPLICATION :

SPECIMEN SOLUTIONS :

1. $4 (9) = 2 (18) = 2 (10) + 2 (8) = 36.$

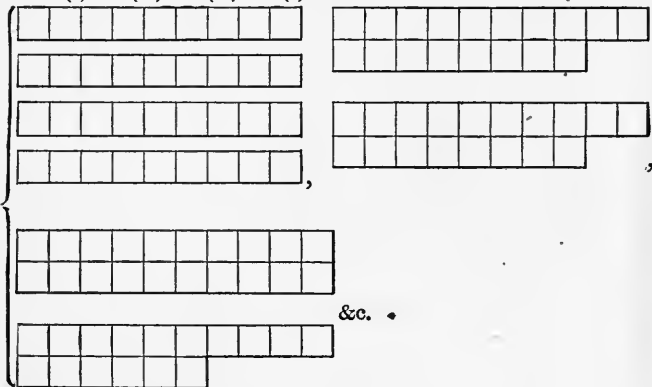

2. $3 (13) = 3 (10) + 3 (3) = 39.$

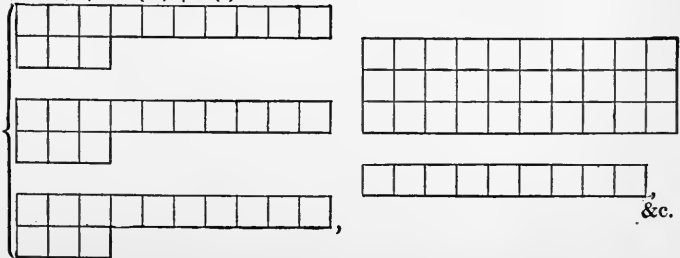

$$3. \quad 9(4) = 3(12) = 3(10) + 3(2) = 36.$$

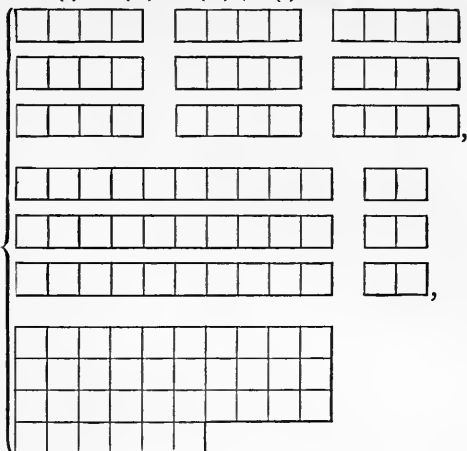

IV. DIVISION :

SPECIMEN SOLUTIONS :

$$1. \quad 24 + 3 = 8(3).$$

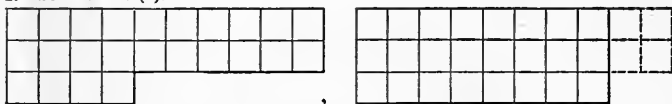

(The four blocks on the right are moved to the lowest row; in the second form the threes may be slightly separated from left to right.)

$$2. \quad 28 + 2 = 10(2) + 4(2) = 14(2).$$

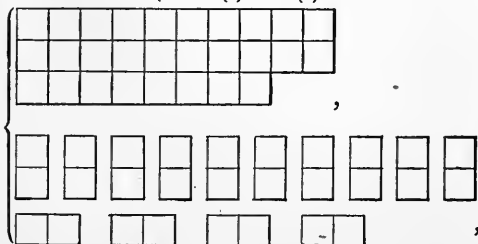

3. $19 + 4 = 4(4) + 3$



V. PART-TAKING :

SPECIMEN SOLUTIONS :

1. $\frac{1}{2}(36) = \frac{1}{2}(30) + \frac{1}{2}(6) = 18$

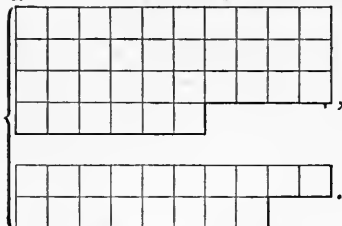

2. $\frac{3}{5}(25) [\frac{1}{5}(25) = 5] = 3(5) = 15.$

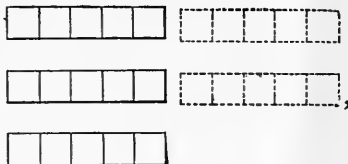
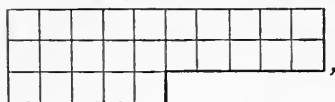

VI. INVOLUTION :

$2^2 = 4$



$3^2 = 9$



$4^2 = 16$

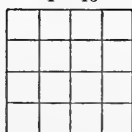

$5^2 = 25$

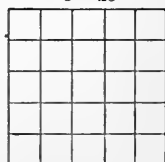

$$6^2 = 36$$

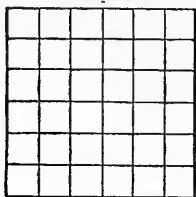

$$2^3 =$$

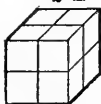

$$8$$

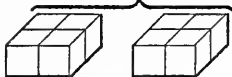

$$3^3 =$$

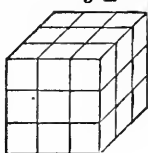

$$27$$

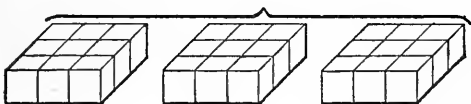

CHAPTER X.

THE FOLDING SHEET.

FOR the exercises to be suggested under this head, paper sheets of various sizes and shapes may be provided. The most convenient for class use are squares of four inches to the side, equilateral triangles of four inches to the side, and circles four inches in diameter. For drawing, I have found a fair quality of unsized manilla wrapping paper quite suitable; although, for some purposes, a good quality of unsized printing paper may be preferred. The same sheets will answer for geometrical exercises; nevertheless, for reasons to be stated hereafter, colored unglazed cover-paper will be found more satisfactory and not very expensive. The square and triangular paper can be cut cheaply on a cutting-machine by the nearest book-binder or job-printer. The circular papers will

have to be ordered from the manufacturer, or cut to order by the children.

In folding, stress should be laid on accuracy, care, and cleanliness; the creases should be sharply defined by drawing the back of the thumb-nail firmly over the folds. In the dictation exercises, the pupils should not change the position of the paper unless by direction, and should not lift the paper from the table until the desired form is completed. I shall show, first, how the sheets may be prepared and used for drawing exercises, and then, how they may be used in form lessons.

I. THE SQUARE SHEET IN DRAWING.

For an introductory exercise, the pupil should study the form features of the sheet before him; he should count and describe the edges, corners, and angles.—[“One edge in front (or below), one edge behind (or above), one edge on the right, one edge on the left.”—“The front (lower) edge and right edge form a *corner*—the right front (lower) corner; the front edge and left edge form a corner—the left front (upper) corner;” etc.—“The front (lower) edge and back (upper)

edge run from right to left;" etc.—“The right and left edges are in the same direction (from front to back) or *parallel*; the front and back edges are in the same direction (from right to left) or *parallel*.”—“The left edge makes a *right angle* with the front edge,—the left edge is *perpendicular* to the front edge,—the front edge is perpendicular to the left edge,—the left and front edges are perpendicular to each other,” etc.—“The lower and upper edges are *horizontal*, the right and left edges are *vertical*.”—Place the fore-finger of the left hand on the front edge,—the fore-finger of the right hand on the edge parallel to this, on an edge perpendicular to it, on the *opposite* edge, on an *adjacent* edge, etc.—Place the fore-fingers on the edges, forming the left front corner, the left back corner, etc.] In all these exercises the technical terms—italized above—should be freely used.

For the first exercises in drawing, the paper is prepared as follows, the teacher dictating: “Place the sheet before you with two edges running from right to left, and two from front to back.—Place the right edge on the left edge, and crease the paper

in the fold.—Open the paper*.—Front edge on back edge; crease; open†.—Right edge on vertical diameter (or crease); crease; open. Left edge on vertical diameter; crease; open. Front edge on horizontal diameter; crease; open. Back edge on horizontal diameter; crease; open.‡

The thirty-five suggestive figures of the subjoined plate indicate how, with the help of the sheet creased into sixteen square inches, as the above dictation teaches, the teacher may secure automatism in drawing straight lines, parallel and diverging, in all directions. Similar series can easily be

* The following facts may here be fixed in lively conversation with the children: "The vertical crease passes through the middle of the paper; it is a *diameter* of the square; it cuts the paper into two equal oblongs; each oblong is the half of the square; the vertical diameter *bisects* the square; it bisects the front edge; it bisects the back edge; it is parallel to the right and left edges; perpendicular to the front and back edges," etc.

† Here facts like these may be brought out in conversation: "The horizontal diameter bisects the right and left edges; it bisects the vertical diameter; the two diameters bisect each other; the two diameters cross at the center of the square; they divide the sheet into four equal squares," etc.

‡ Here the fact that the paper is divided into smaller squares may be noticed, and the squares counted.—"How many rows of squares from right to left; how many from front to back; how many squares in each row; how many in the paper?"—The number of creases, their relative directions, the angles which they form, and other things may be noticed and distinctly announced by the children in full, clear sentences, until they are quite familiar with the paper and love it for the pleasure obtained from it.

constructed by the teacher for the practice of curved lines, although, for this purpose, other appliances are preferable.

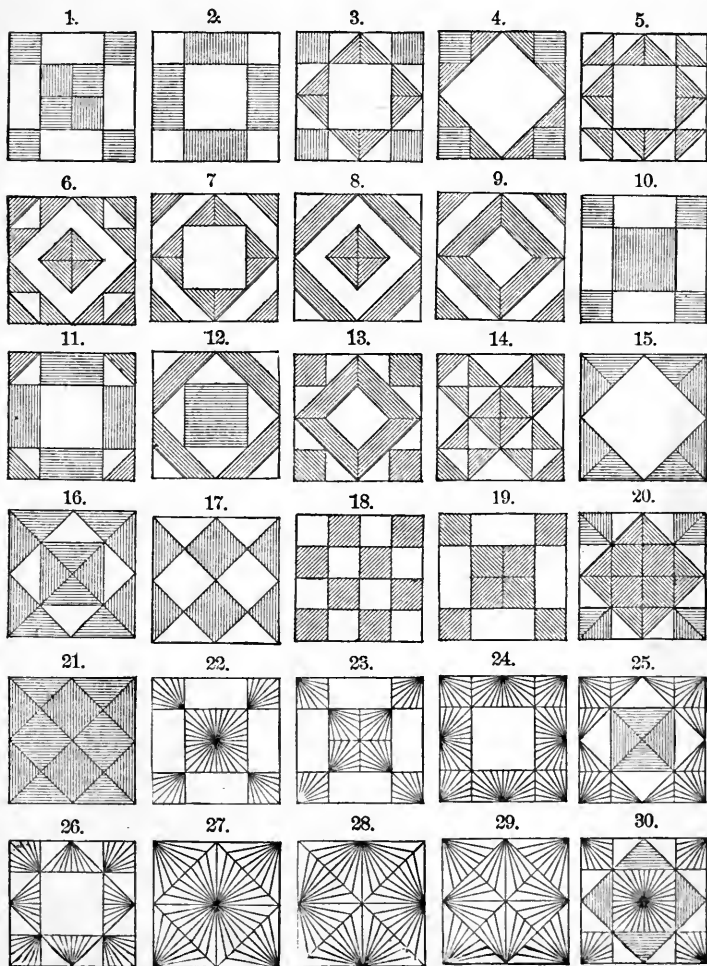

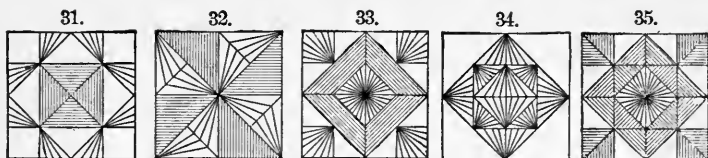

II. THE EQUILATERAL TRIANGLE IN DRAWING.

Here again, for an introductory exercise, the pupil may study the form features of the triangle—the position of its edges and corners, the equality of its sides and angles. The sheet may then be prepared for drawing, as follows: “Place the sheet before you, one edge in front from right to left, the other two slanting backward. Place the right (slanting) edge on the left (slanting) edge, and crease the paper in the middle.—Open the paper.* Front edge on left slanting edge,—crease,—open.—Front edge on right slanting edge,—crease,—open.”—(In Fig. 1 of the plate of suggestive figures on the next page, the resulting creases are indicated by the lines *c d*, *a e*, *b f*.)†—“Place the

* Here the following facts may be brought out: “The crease lies from front to back; it bisects the front edge; it bisects the triangle; it bisects the back angle; it is perpendicular to the front edge; it cuts the triangle into two equal, right, scalene triangles.”

† Here it may be noticed that the three creases (or altitudes)

back corner on the middle of front edge,—crease,—open;—right corner on the middle of left edge,—crease,—open;—left corner on the middle of right edge,—crease,—open.”— (In Fig. 1, the creases are shown by the lines $e f$, $e d$, $f d$.)*

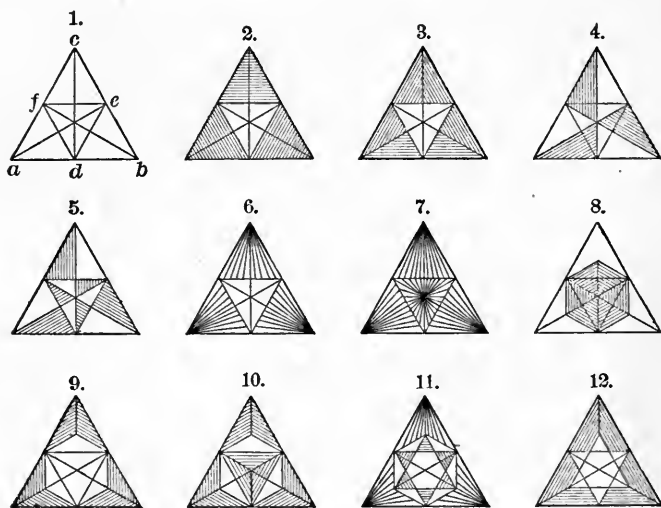

intersect at a common point, the *center* of the triangle, that they divide the triangle into six equal, right, scalene triangles; that the two triangles in front (on the right, on the left) form an isosceles, obtuse triangle; that the two triangles in the right (left, back) corner form a trapezium, etc.

* Here it may be noticed that the three short creases divide the equilateral triangle into four smaller equal equilateral triangles; that the short *crease* from right to left ($f e$) is parallel to the front edge, and divides the sheet into a trapezoid and a small equilateral triangle, etc.

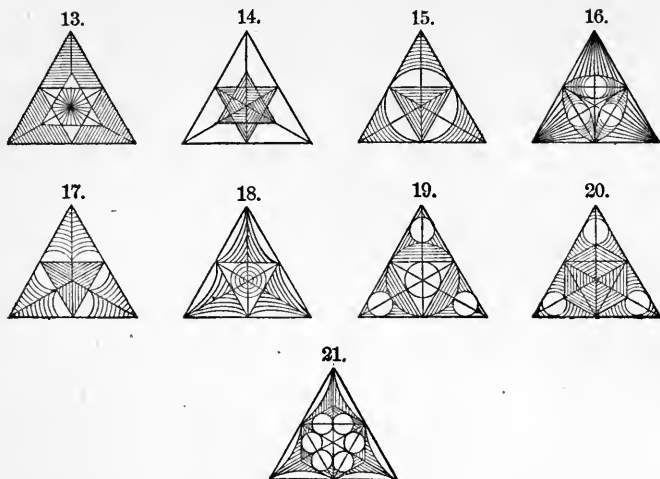

III. THE CIRCULAR SHEET IN DRAWING.

The sheet is prepared as follows (Fig. 1, in the plate on the next page): Front half on back half,—crease,—open (ab)*;—right half on left half (or right end of diameter on left end),—crease,—open (cd); †—right quadrant in front on left quadrant behind,—crease,—open (gh);—left quadrant in front on right quadrant behind,—crease,—open (ef).

For the suggestive Figs. 8-14, each half

* Facts to be brought out in conversation: The crease ab bisects the *circle*; it bisects the *circumference*; each half of the circle is called a *semicircle*; the crease is a *diameter*.

† Facts to be brought out: The two diameters bisect each other; they cross at the *center* of the circle; they divide the circle into four equal parts; each of these parts is a *quadrant*.

quadrant is again bisected by an additional crease.—For Figs. 15, 16, 17, the front and back ends of the diameter cd (lying from front to back), and the right and left ends of the diameter ab are successively folded on the center, giving chords parallel to these diameters. For Figs. 18-21, each semicircle is trisected, and in Fig. 21 each sextant is subsequently bisected.

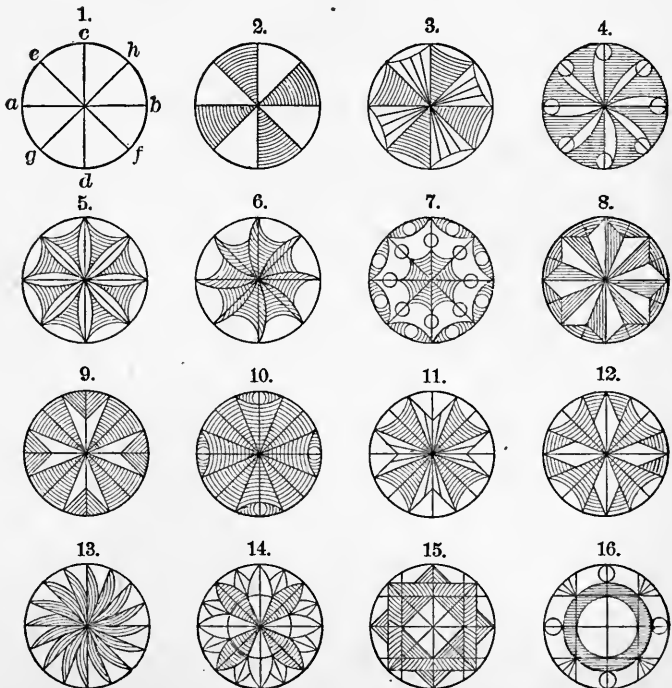

17.

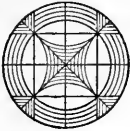

18.

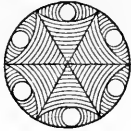

19.

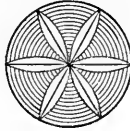

20.

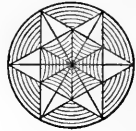

21.

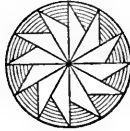

CHAPTER. XI.

THE FOLDING SHEET (Concluded).

IN the annotations of the previous chapter, I have indicated to some extent how, in the preparation of the drawing-sheets, rudimentary notions on form and direction may be brought out and fixed. In the present chapter, I shall suggest exercises which are very serviceable in more or less systematic lessons on form.

I. THE SQUARE SHEET IN FORM LESSONS.

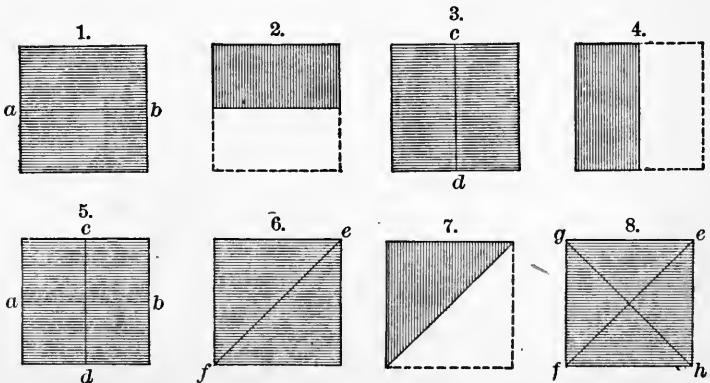

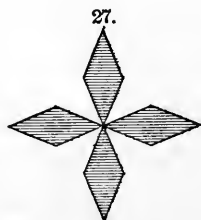
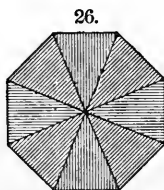
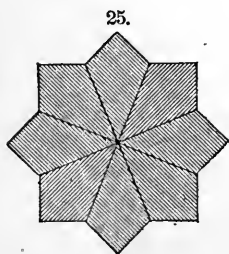
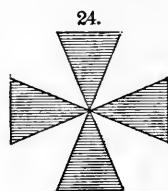
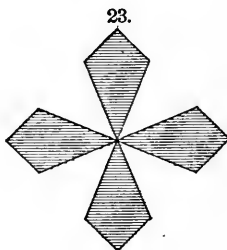
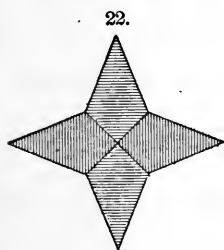
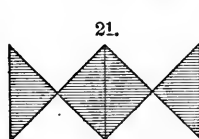
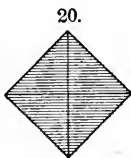
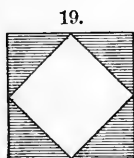
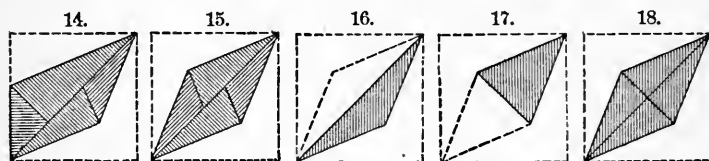
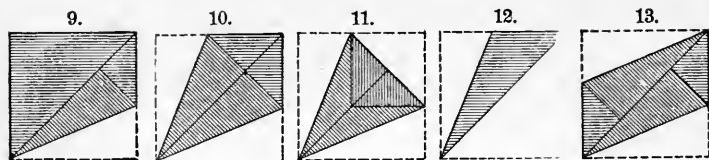

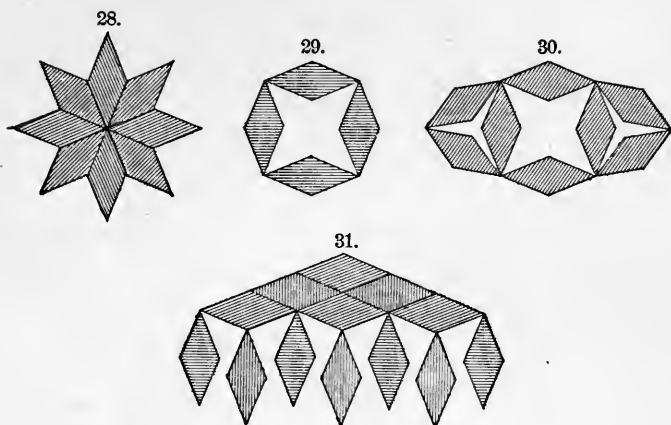

A square sheet of paper may be laid before each child. Simple observation will bring out in oral or written work, series of facts or statements like the following, suitable for various stages of progress: (a) "The paper is square. It has four sides. It has four corners. It has four right angles."—(b) "The right side of the square is parallel to the left side; the lower side is parallel to the upper side. The right side is perpendicular to the upper (and lower) side; the left side is perpendicular to the upper (and lower) side, etc. The opposite sides are parallel; the opposite sides are equal. The adjacent sides are parallel (equal)." (c) "The square has four sides; it is a quadrilateral.

Its opposite sides are parallel; it is a parallelogram. Its sides are equal; it is an equilateral parallelogram. Its angles are right; it is a right parallelogram. It is a right, equilateral parallelogram."

The children may be requested to fold the lower side on the upper one, to crease and open (Fig. 1 of the above table): "The crease bisects the square; it bisects the right (left) side. It is a diameter. This diameter is horizontal. It is perpendicular to the right (left) side. It is parallel to the upper (lower) side."

Similarly the children may study, in Fig. 2, the oblong; in Fig. 3, the vertical diameter; in Fig. 4, another oblong; in Fig. 5, the two diameters; in Fig. 6, one diagonal; in Fig. 7, the right isosceles triangle; in Fig. 8, both diagonals, etc. In the figures the blank spaces inclosed by dotted lines show the portion of the paper folded on the hatched part of the figure.

For Fig. 9 (trapezoid), after creasing a diagonal, the lower side is folded on the diagonal. The subsequent folding of the left side on the same diagonal, gives the trapezium, Fig. 10. From this we obtain

Fig. 11 by folding the right isosceles triangle of Fig. 10 inward. Fig. 12 (scalene obtuse triangle) comes from Fig. 10 by folding the lower half upon the upper half of the trapezium. Fig. 13 (rhomboid) comes from Fig. 9 by folding the upper side upon the diagonal. From this Figs. 14, 15, 16, and 17 are easily derived.

For Fig. 18, the child has been directed to open the last fold of Fig. 17, and to turn the lozenge over. On the reverse side, the two diagonals will be distinctly observed, and the child may be taught to see and say: "The long diagonal bisects the short one. The short diagonal bisects the long one. The two diagonals bisect each other. The short diagonal is perpendicular to the long one. The two diagonals are perpendicular to each other," etc.

The remaining figures (19-31) suggest exercises in the social synthesis of the forms obtained. Thus, for Fig. 19, four children have placed together the right isosceles triangles obtained by folding Fig. 7, so as to inclose a slanting hollow square. Other combinations of the same form are shown in Figs. 20 and 21. Similarly, Figs. 22, 23,

and 25 show combinations of the trapezium (Fig. 10); Figs. 24 and 26, of the isosceles triangle (Fig. 11); and Figs. 27-31, of the lozenge (Fig. 15).

The designs may be pinned to the wall or pasted on manilla paper, and thus utilized in ornamenting the school-room and as patterns for drawing or coloring.

II. THE EQUILATERAL TRIANGLE IN FORM LESSONS.

After what has been said concerning the square sheet, little need be added in explanation of the following cuts:

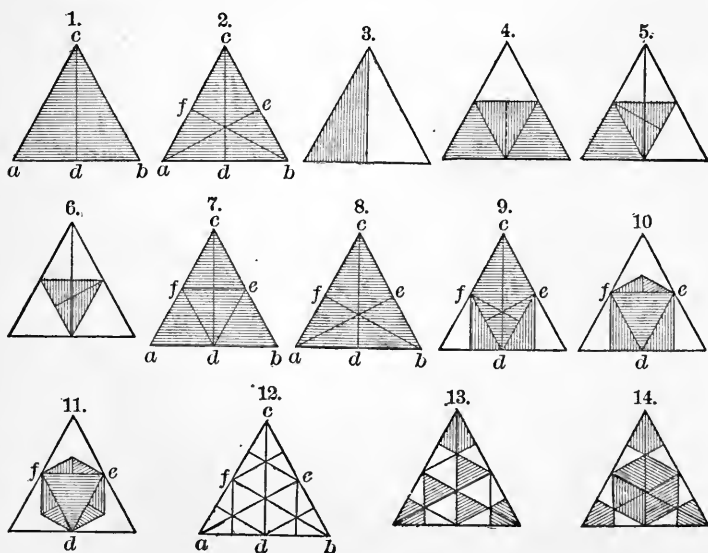

In Fig. 1 the child studies the equilateral triangle as such and, after folding the right half upon the left and opening the paper, the relation of the altitude to the triangle. In Fig. 2, he studies the three altitudes; in Fig. 3, a right scalene triangle (half of the equilateral); in Fig. 4, a trapezoid; in Fig. 5, a lozenge; in Fig. 6, a new smaller equilateral; in Fig. 7, after opening all the folds, the relations of parts. Figs. 8-11 show the growth of the hexagon; and Figs. 12-14 give some additional hints, on the basis of the net-work obtained in the last series of foldings, concerning a new line of drawing and coloring designs.

III. THE CIRCULAR SHEET IN FORM LESSONS.

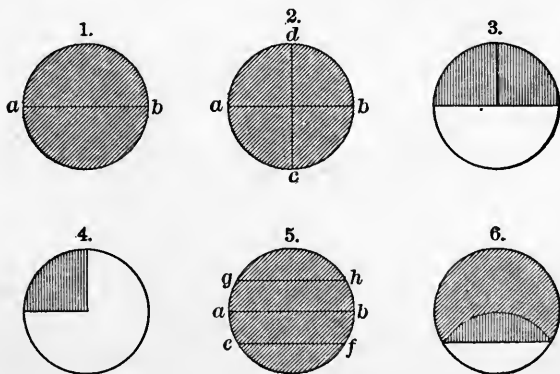

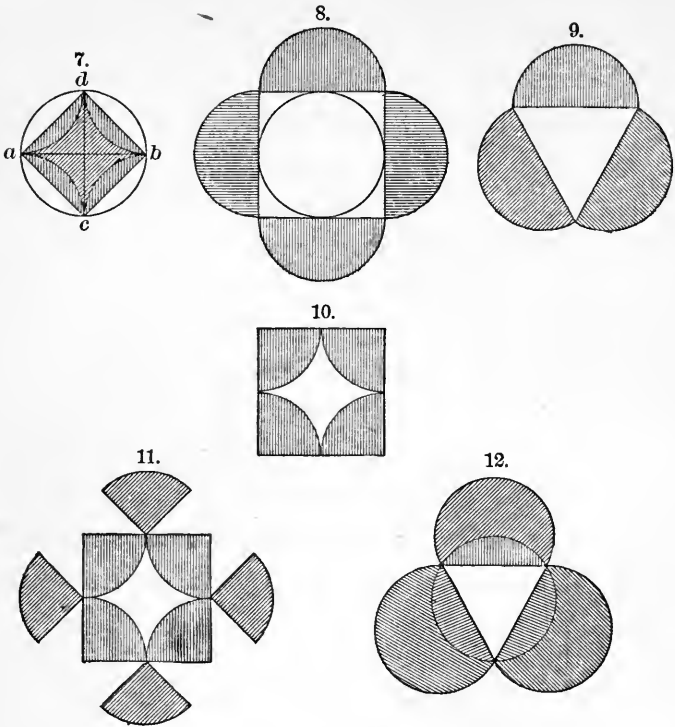

Fig. 1 represents the sheet re-opened after the creasing of the horizontal diameter; Fig. 2, the same after the creasing of two perpendicular diameters; Fig. 3, the semi-circle; Fig. 4, a quadrant; Fig. 5, parallel chords; Fig. 6, segments; Fig. 7, the inscribed square. Figs. 8-12, suggest social syntheses.

These suggestions must suffice. For the

thoughtful teacher they will open many avenues to rich fields of investigation on the subject of form, in many grades of the school. To her, however, as in previous cases, I must leave the task of selecting and adapting the exercises and of preparing the details of each lesson.

In all folding exercises it is essential for permanent success to secure neatness and promptness; neatness first and foremost, and then promptness. Never, under any circumstances, sacrifice the former to the latter. For this purpose, it is well strictly to observe a few rules, even at the risk of some pedantry:

1. Insist that all folding and creasing be done on the table; never allow the children to lift up the paper and do the folding and creasing in the air.

2. Insist that the paper be kept in the same position during the entire dictation, not turned so as to bring the right side in front when the direction is given to fold from right to left, etc.

3. Insist that point shall lie accurately on point and edge on edge, before any creasing is attempted.

4. Insist that the creasing be done slowly and deliberately with the back of the thumb-nail or some suitable instrument, such as a paper-knife.

5. Insist that the creasing be done thoroughly, so that the folds may lie flat.

6. Insist that in opening the folds the child keep the paper smooth and avoid all crumpling.

7. Dictate slowly, deliberately, with ample pauses, avoiding nervous repetition.

CHAPTER XII.

PLASTIC CLAY.

IN very many localities this material may be had for the digging. Elsewhere it may be procured from potteries at rates varying from $\frac{1}{4}$ to 3 cents per pound. It may be broken up in a pail, moistened with water; worked into suitable consistency, wrapped in a moist cloth, covered with an oil cloth, and laid aside for use. When ready for work the teacher may slice off pieces of suitable size with a piece of copper wire of convenient length. Each child is furnished with a modeling board about one foot square, which will be cut to order at the planing-mill for five or six cents a piece, and with a modeling knife which may be bought at 25 cents per dozen or whittled out of soft wood by the boys. The knives should be six inches long, the

blade three fourths to one inch wide, of a shape indicated by the following cut:



In fashioning the clay, the children use only gentle pressure with the thumbs and fingers. Violent pressure and beating are as inexpedient as they are unseemly. For smoothing, after the fingers have done their best, the blade of the knife is drawn gently over the surface with a minimum of pressure. For trimming the edges and carving, the knife blade is used like that of an ordinary knife. For engraving designs on the surface of the clay, the point of the handle is used. On account of the softness of the surface, gentleness and delicacy of touch are imperative. Thus the work with clay becomes an excellent corrective of the injurious influences of slate-work upon the hand, as well as an excellent school of patient, thoughtful persistence.

The easiest and most fertile work for primary grades, with endless resources for the exercise of inventive power and manual skill, lies in the manufacture of tiles of

various shapes; in succession of difficulty,—square, circular, octagonal, hexagonal, triangular (equilateral), pentagonal. With children who have not enjoyed the advantages of kindergarten training, the first few lessons should be devoted to free random exercises or play with the clay. They may be allowed to make marbles, cakes, loaves of bread, birds'-nests, and birds, snakes, and hundreds of other things according to their fancy. This will render them familiar with the plastic properties of the material, and will thoroughly arouse their interest. During these play-lessons, too, the need of gentleness in handling the clay should be inculcated; the children will soon learn that easy, delicate treatment yields better results.

For the manufacture of the square tile, each child receives about two cubic inches of clay. By gentle pressure with the fingers, this is spread out on the modeling board in a flat cake, about $4\frac{1}{2}$ inches square, and not quite one fourth inch thick. The surface of this is scraped smooth with the clay knife, and the edges are trimmed so as to leave a smooth tile, four inches square. The

teacher, in passing from child to child, giving directions, helping, and encouraging (or one of the children appointed for this purpose), is constantly busy picking up from the boards scraps of clay; this will insure neatness and respect for the material.

With the help of the ruler and the pointed knife-handle, or some other suitable style, the children may then analyze the surface in a variety of ways, reaching more or less complicated net-works for guidance in exercises of engraving, carving, or painting. The following figures indicate the principal ones of these net-works. The figures on page 77, Chapter X., suggest exercises for drawing or engraving. Exercises for carving and coloring will readily suggest themselves to a thoughtful consideration of the net-works. In Figs. 12, 13, and 14, the net-works appear as little picture-frames to be filled according to the child's taste and skill.

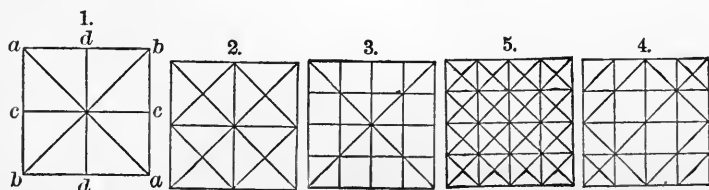

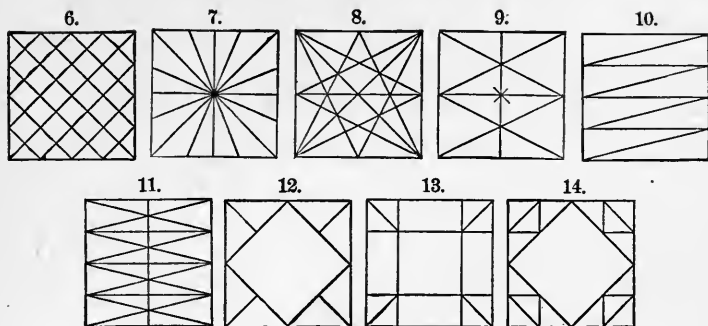

In the manufacture of the circular tile the child proceeds as above. When the tile is ready for trimming, he may stick a stout pin near the center of the tile, tie another pin to a piece of thread about ten inches long, pass this thread around the central pin so as to obtain a radius of four inches, and with the free pin mark the circumference of the circle on the tile. The excess of clay is then trimmed off with the clay-knife, and the tile is ready for work in accordance with previous suggestions, and on the basis of net-works, indicated below.

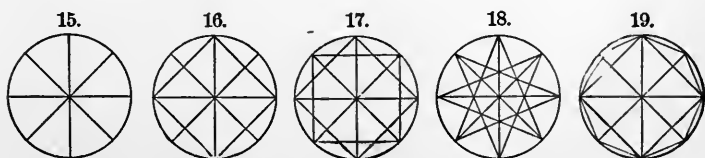

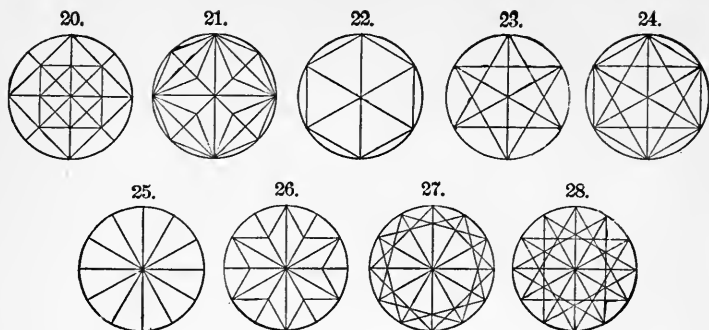

The circular tiles offer convenient surfaces for practice with dividers in the drawing of circles and circular arcs, as indicated in the following cuts. One of the points of the dividers may be protected with a small disc of card-board to keep it from penetrating too far into the plastic clay. In the place of dividers, two pins and a thread, as above, will answer the purpose. The following figures suggest some

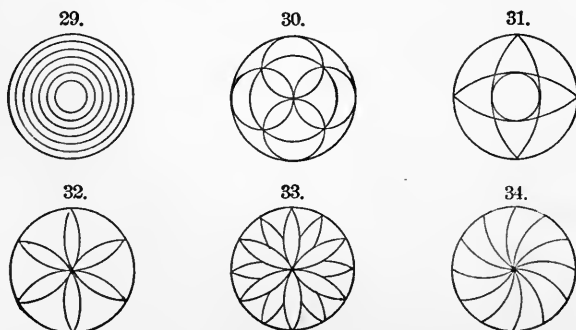

such exercises. The various fields may be painted in different colors to make the forms more impressive and to please the children.

In the making of solid forms, similar directions hold good. The pupils should, again, rely chiefly on gentle pressure with the thumbs and fingers; all beating and hammering should be discountenanced. For purposes of smoothing and decorating the faces of the solids, the same instruments and expedients are used as in the making of tiles. The fashioning of the solids offers excellent opportunities for the education of the sense of touch with reference to shape. Much is gained in this direction by requesting the children frequently to close their eyes while going through the initial processes of coaxing the clay into the required shape. This will not only add a new interest to the exercise, but will help to clear the children's notions of shape, by inducing them to concentrate their attention on the sense of touch as the true shape sense. In all cases, much heed should be given to efficient means for interesting the child in the shapes under considera-

tion. These means are found chiefly in the decoration of the pure shapes, and in their modification and combination for imitating objects. The various shapes are best considered in the following order:

(1) Cube; Square Prism; Square Pyramid.

(2) Cylinder; Prisms of three, six, eight, five sides.

(3) Cone; Pyramids of three, six, eight, five sides.

(4) Sphere; Spheroids; Tetrahedron and Octahedron.

The teacher's tact and opportunities must decide to what extent each of these shapes can be used in the study of objects and of geometrical relations, as well as in drawing and coloring. In my experience I have found them of great value in all grades of the Primary and Grammar Departments.

CHAPTER XIII.

CUTTING AND MOUNTING.

THE materials for this occupation are the square, circular, and triangular folding sheets and suitable paper or card-board for mounting. For the latter purpose, stout manilla wrapping paper, cut in pieces seven to nine inches square, is quite serviceable. A pair of cheap blunt-pointed scissors, a small dish or bottle with mucilage, a small clean piece of cotton cloth, and a camel-hair brush complete the outfit.

The simplest and, for primary school use, the most efficient method of preparing the square sheet, is indicated in the following dictation: "Lay the sheet before you, the front (nearest) side from right to left; lay the front edge on the back edge, crease in the fold, open the paper; the right on the left edge, crease, open; the front edge on the middle (horizontal) crease (diameter), crease, open; the back on the horizontal

diameter, crease, open; the right on the vertical diameter, crease, open; the left on the vertical diameter, crease, open.” (These creases divide the sheet into sixteen square inches, Fig. 1.) “Fold the front edge again on the back edge; the left (short) edge on the right (short) edge.”

The paper is now ready for work (Fig. 2). The point *c* indicates the center of the original large square sheet; the dotted lines show the creases which serve as guides in cutting. In the subsequent figures (3-19), the heavy lines indicate the cuts. Thus, in Fig. 3, the left and lower margins are marked heavy. The paper is cut in these lines, and thus divided into four smaller squares of four square inches each, which may be arranged in a variety of new ways and mounted on a suitable sheet of paper or card-board, or used as rudimentary exercises in mensuration.

In the following cut, Figs. 3-15 suggest a number of rectilinear cuts; Figs. 16-19, a few combinations of rectilinear with circular cuts; and Figs. 31-36, two cuts diverging from the center, combined with other available cuts.

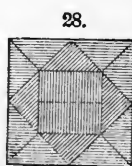
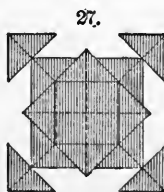
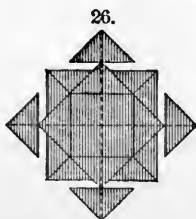
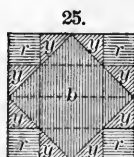
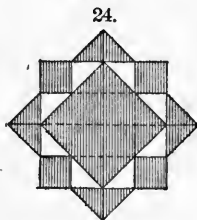
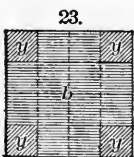
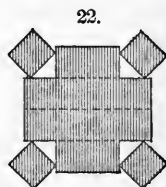
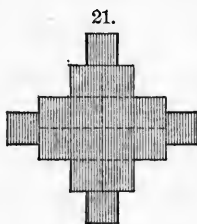
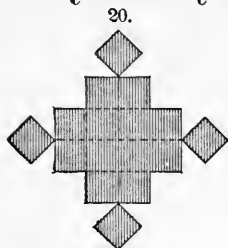
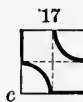
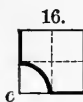
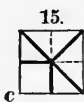
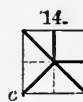
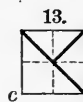
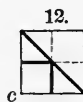
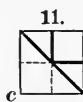
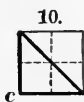
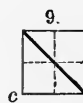
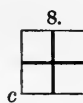
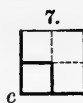
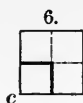
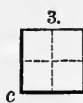
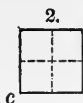
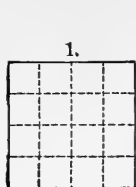

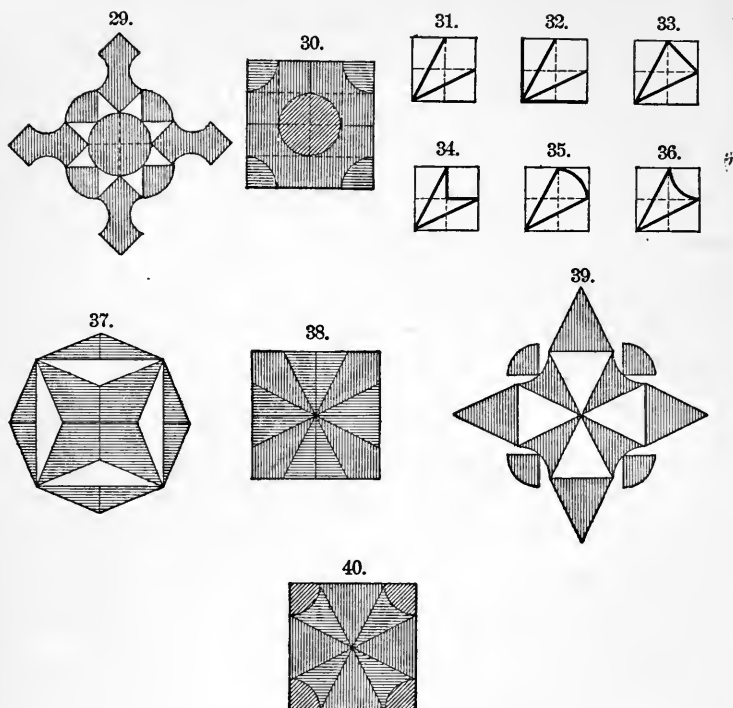

Figs. 20, 21, and 22 show three arrangements (or syntheses) made with the pieces resulting from the cut (analysis) indicated in Fig. 4.

For the arrangement of Fig. 23, two children who had sheets of different colors, have exchanged the squares. If one of these had a blue, and the other a yellow sheet, Fig. 23 would, then, represent a square

made up of a blue (yellow) cross, with a yellow (blue) square laid in each corner. In the figure, the difference in color is indicated by the different directions of the hatching lines. The same device has been used for a similar purpose in Figs. 25, 28, 30, 38, and 40.

Fig. 24 is a re-arrangement of the pieces obtained from Fig. 11.

Fig. 25 is a reconstruction of the square, after an exchange of forms among three children; perhaps the large central square is blue, the small triangles red, and the small squares in the corners yellow. The other two children will, then, have similar reconstructions with the same colors in different arrangements.

Figs. 26, 27, and 28 are obtained from the cuts of Fig. 15; Figs. 29 and 30, from the cuts of Fig. 17; Figs. 37 and 38, from the cuts of Fig. 32; and Figs. 39 and 40, from the cuts of Fig. 36.

It is scarcely needful to point out the ample opportunities which these exercises offer, for the varied and interesting use of geometric language, and for the cultivation of the esthetic sense with reference to

form and color; to speak of the certainty with which a thoughtful use of this charming work will lead the child to important discoveries concerning the laws of the equality, similarity, and equivalence of figures; or to indicate how much these exercises will aid the child in the work of drawing and coloring:

After these explanations, very little need be added in elucidation of the subjoined cut, suggesting the treatment of the circular sheet.

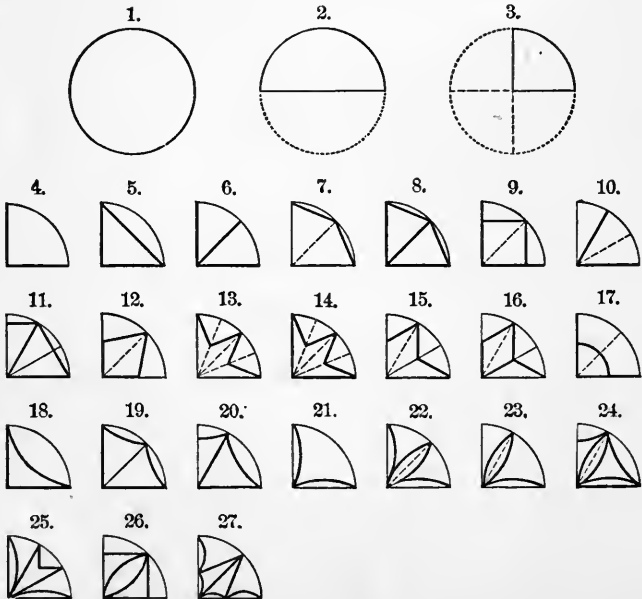

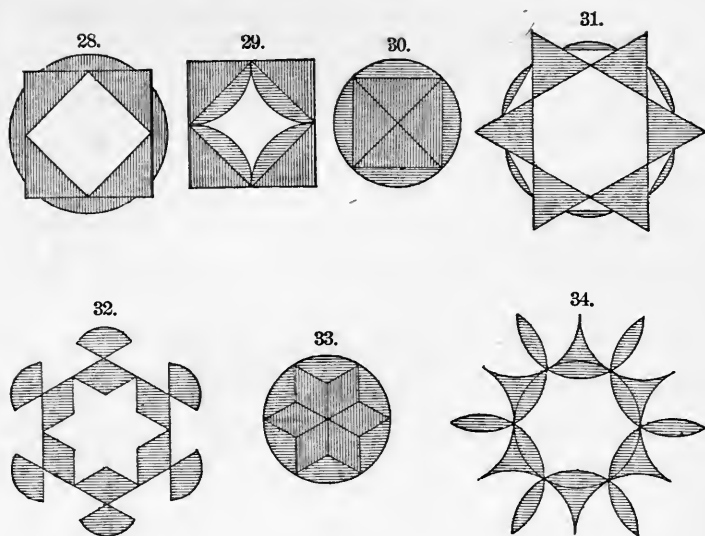

Figs. 1, 2, and 3 represent the circular sheet, respectively, (1) laid before the pupil, (2) the lower half folded on the upper half, (3) the left half on the right half. In Figs. 4 to 27, the heavy lines indicate the cuts to be made on the quadrants. Figs. 28, 29, and 30, suggest arrangements of the pieces from the cuts of Fig. 5; Fig. 31 comes from Fig. 11; Figs. 32 and 33, from Fig. 16; Fig. 34, from Fig. 23.

.For the use of the equilateral triangle (four-inch side), the following cut will give the needed directions.

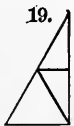
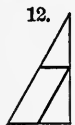
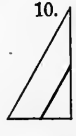
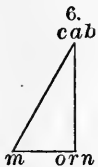
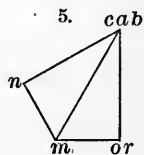
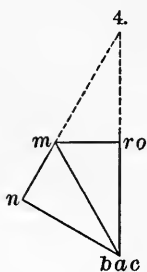
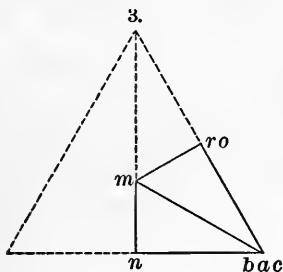
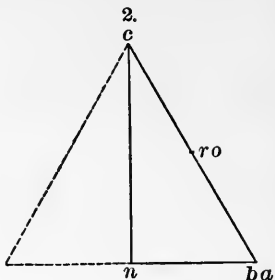
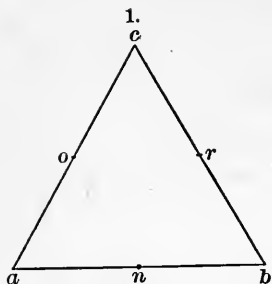

Figs. 1-6 indicate the successive steps in the preparation of the sheet for cutting. a, b, c mark the vertices of the triangle; n, o, r , the middle of the sides; m , the center of the triangle. The dictation may take the following form: Lay the triangle before you, one side in front, from right to left (Fig. 1); lay the left slanting side (ca) on the right slanting side (cb), and crease the paper in the fold (cn) (Fig. 2); lay the back point (c) on the right point in front (ba) (Fig. 3); move the back part of the paper to the right, and lay the right side from front to back (Fig. 4); turn the paper over forward (Fig. 5); lay the left (slanting) side on the right (vertical) side (Fig. 6). The sheet is now ready; the vertices of the triangle are all in the same point (cab), the middle points of the sides in orn , and the center of the sheet in m .

Figs. 7-21 indicate simple rectilinear cuts, bisecting sides and yielding a great variety of geometrical forms for exercises similar to those suggested in the treatment of the square and circular sheets. Figs. 22-28 suggest a few curvilinear cuts.

The subjoined foldings of the square

sheet, given in kindergarten manuals, I have not found as available in primary work as those just treated, which have the advantage of greater simplicity in preparation and in the forms resulting from the cuts.

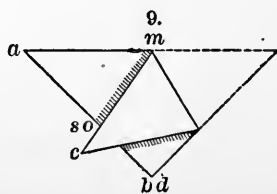
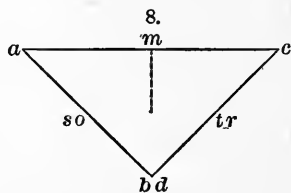
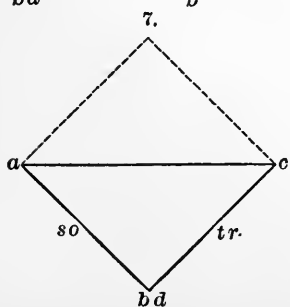
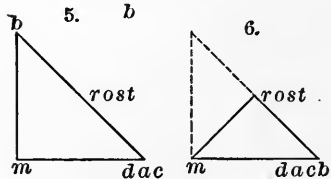
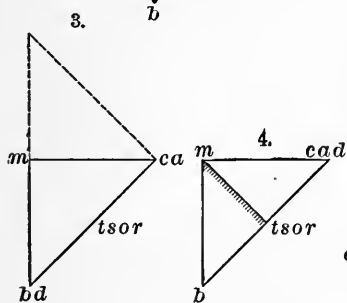
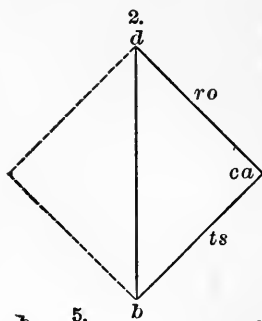
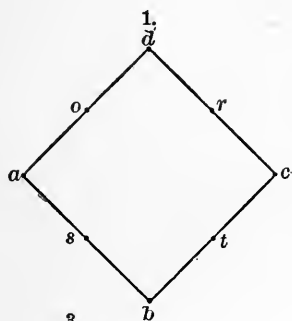

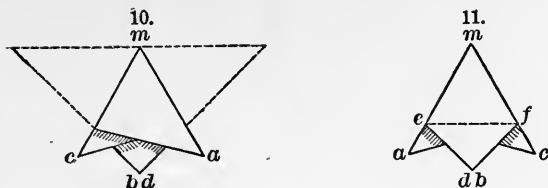

Fig. 1 shows the square folding sheet in position, "one corner in front and all sides slanting"; for Fig. 2 the left corner a has been placed on the right corner c , and the paper creased from d to b ; for Fig. 3 the back corner d has been placed on the front corner b , and the paper creased from m to ca ; for Fig. 4, the corner or point d has been lifted from b and folded on ca , bringing the points cad together; Fig. 5 shows the form turned over backward in order to bring the point b to the top; for Fig. 6 the point b is folded on the points acb , and the paper creased from m to $rost$. This unites all the corners or angles of the square in the one point $dacb$, all the middle points of the sides of the square in the point $rost$, and exposes the center of the square at the point m . The folding sheet is now ready for such cuts as the teacher or pupil may devise, and all cuts will produce symmetrical results.

Fig. 7 shows the first fold of a second series starting from the position of Fig. 1; for Fig. 8, the left point (*a*) was laid on the right (*c*), and the paper slightly creased at the point *m*; for the fold of Fig. 9, the angle at *m* should span 120° ; in Fig. 10, the angle at *m* is 60° ; for Fig. 11, the paper is turned over from left to right; the portion below the line *ef* is clipped off, and the form is ready for work.

CHAPTER XIV.

CARD-BOARD WORK.

THE cheapest and most satisfactory material for card-board work is a stout manilla board, which the printer or binder may cut of the required sizes,—usually from six to twelve inches square. A pencil, a ruler, a pair of dividers, a sharp knife, some pieces of clean paper, a little mucilage, and a cutting-board, twelve inches square, complete the outfit. For the sake of securing a fair amount of skill in the treatment of the material and the use of the tools, the pupils may first practice, in a few lessons, the drawing and cutting out of given numbers of figures of given forms and dimensions. Tasks like the following may be set:

(1) Draw and cut out six squares, 2×2 inches.

(2) Draw and cut out six equilateral triangles, each side two inches long.

(3) Draw and cut out six hexagons, each side two inches long.

(4) Draw and cut out six pentagons, from circles of two inches diameter.

(5) Draw and cut out six two-inch squares, and bisect them into two triangles.

(6) Draw and cut out six equilateral triangles (two inches to the side), and trisect each into three triangles.

The pieces resulting from the solutions of these tasks should be re-arranged symmetrically by the pupils, and the resulting forms and angles studied. The following figures suggest some of these arrangements for the first two tasks: Figs. 1 and 2, for the first; Figs. 3 and 4, for the second; Fig. 5, for both combined.

The forms thus obtained offer elements

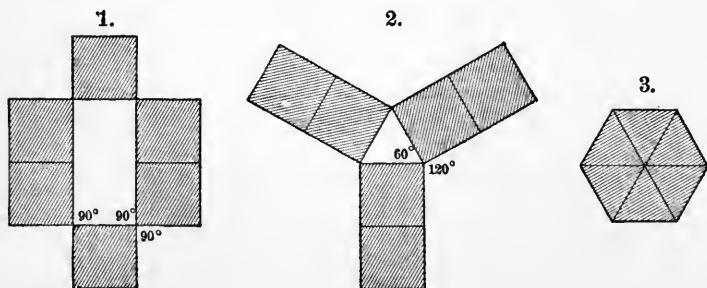

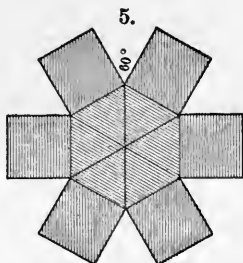
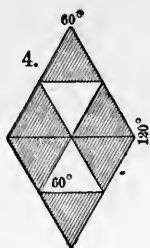

for designs in drawing, and furnish themes for form lessons for all grades of primary and grammar schools.

Next, in point of difficulty, would be a series of exercises in making hollow forms or "boxes." Some of these forms are suggested in the following figures, on the bases, successively, of the square, oblong, equilateral triangle, lozenge, and hexagon:

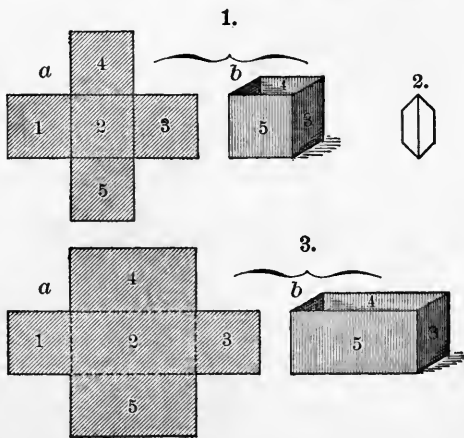

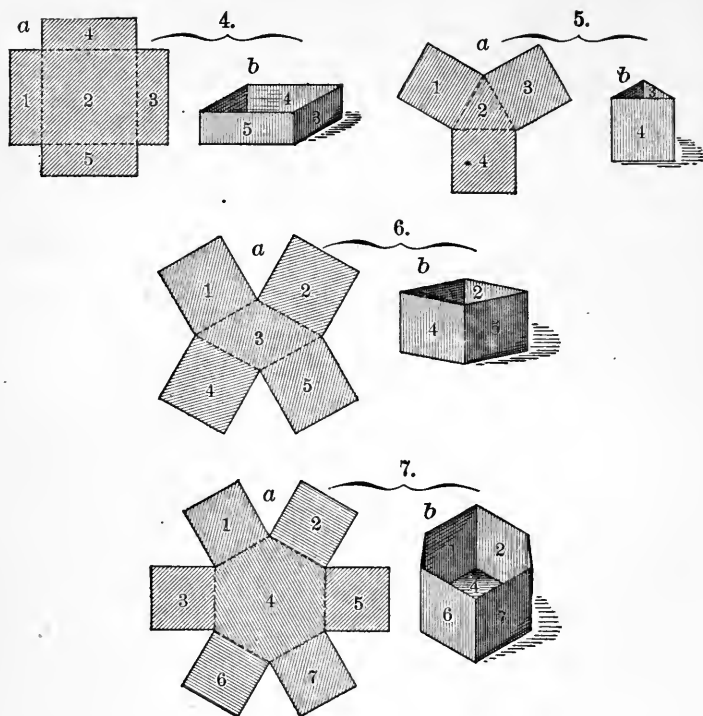

The outline is first carefully drawn on the card-board; this gives opportunity for practice in the use of instruments for geometrical drawing. The dotted lines (shown in *a* of each pair of figures) is then cut half through the paper with the help of a ruler and a sharp knife; this enables the pupil subsequently to fold the sides of the boxes upward, as shown in *b* of each pair

of figures. Fig. 2 represents the shape of small pieces of paper or "binding slips," cut of the required length for binding the faces at the edge of the boxes. The middle line represents a crease; this is placed exactly over and along the edge, and each half of the "binding slip" is firmly pasted on the two adjacent faces forming the edge. For the box (b) in Fig. 1, eight such slips of equal length would be required, four for the sides, and four for the bottom and sides; for the box of Fig. 2 it would be necessary to prepare six slips of one length and two of double that length, etc.

The last step, the manufacture of solid forms, offers now little difficulty. Figs. 8, 9, and 10 show that by the addition of one surface the box forms 1, 3, and 4 are changed into solids, a cube and two square prisms. A little patience and care will overcome the slight difficulty of fastening the lid or sixth surface. Figs. 11, 12, and 13 show the way to the construction of the triangular prism, the square pyramid, and the regular tetrahedron. Figs. 14, 15, and 16 give the net-work for the regular octahedron, icosahedron, and dodecahedron.

By substituting, for the triangles 4 and 5 in Fig. 11, hexagons, octagons, or pentagons, and adding the required numbers of rectangles (three, five, or two, respectively) the six-sided, eight-sided, or five-sided prisms will be obtained. By similar changes in Fig. 12, corresponding pyramids will result.

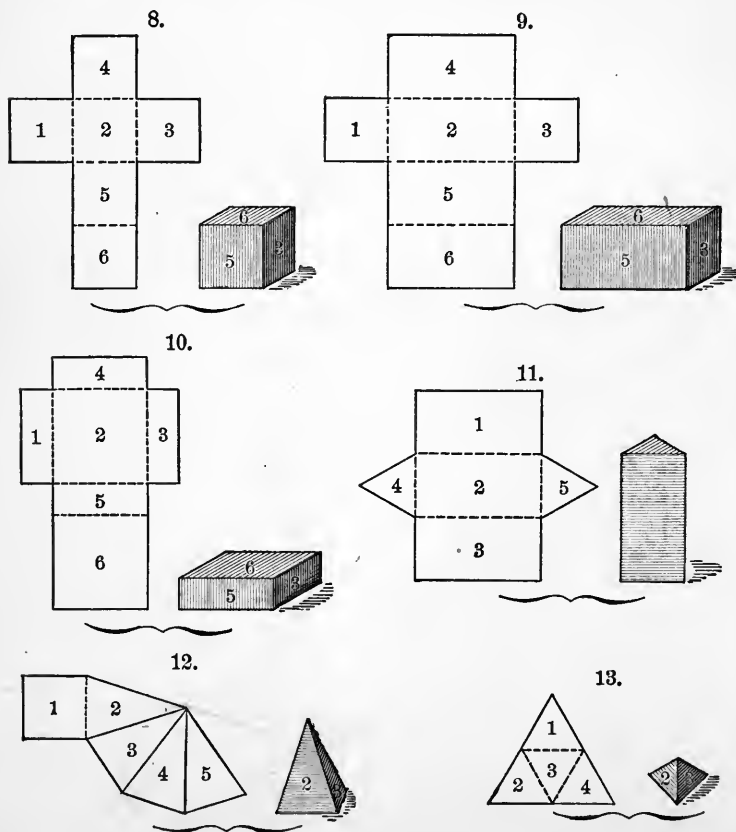

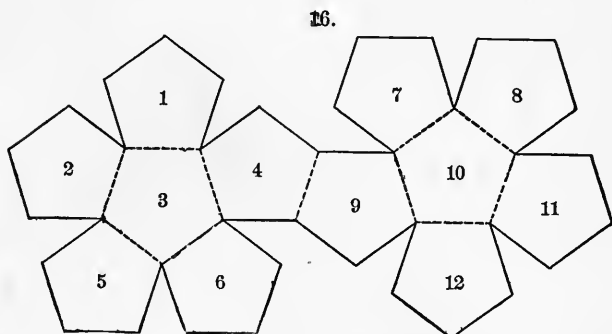
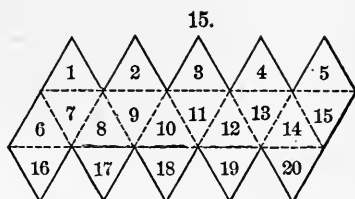
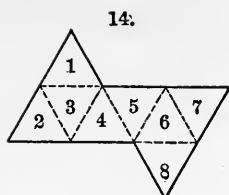

It is evident, without further explanation, that these forms may be used profitably in all grades of primary and grammar schools for a variety of exercises in rudimentary form lessons, mensuration, drawing, and solid geometry.

It is evident, too, that where circumstances permit, the pupils may from the same material, with little difficulty, fashion models of pieces of furniture, buildings, and a number of objects for purposes of drawing; and that geometrical analysis and synthesis will find the material serviceable at every step.

In all cases, it is desirable to give directions in few words, setting a clearly defined task on the basis of which the pupil may do the work independently. He should first assure himself of the correctness of his solution by carefully drawing the outline of the cuts on a piece of paper, as in Figs. 8, 9, 10, 11, 12, 13, 14, 15, and 16. Subsequently the drawing should be transferred to the manilla board, and the work may then proceed as indicated above.

CHAPTER XV.

FRACTION STRIPS.

ANY kind of strong, thin, well calendered paper will answer the purposes of these strips. The children, however, will be best pleased with strips cut from tinted cover paper or "engine-colored" paper. The paper may be bought by the quire or ream, and cut to order by the printer or binder. For use in numbers, as "fraction strips" proper, they should be one half or (later) one third inch wide, and twenty or twenty-four inches long. For use in form lessons, as intertwining strips, they should be one inch wide.

In forming the first definite notions of fractions, the child should have objects which he can actually *break up* into parts of one, in such a way that the parts can readily be re-arranged in the order of the original *whole*, or of new *wholes* dictated by the teacher or invented by the child. To

this, in the limits of $\frac{1}{2}$ to $\frac{1}{12}$, the fraction strips are well adapted.

For a first exercise with *halves*, the following is suggested: Place a (twenty-inch) strip before you from left to right. Lay the right half on the left half; crease the strip in the fold; open the strip (Fig. 1); carefully tear the strip in the crease.—Lay one half from left to right; lay the other half parallel to the first one inch (two, three, etc., inches) in front (behind) it.—Lay one half from front to back; lay the other half parallel to the first one inch (two, three, etc., inches) to the right (left) of the first; and so on through a variety of relative positions, as indicated in Figs. 2 to 8.

In each of these re-arrangements the child recognizes a new unit in which the two halves unite more or less completely into a *whole*. The child's attention may be directed to this cautiously and without urgency; in no case, however, should the growth of the ideas—one whole is two halves, two halves are one whole—be interrupted by premature formal statements or by abstract philosophizing thereon.

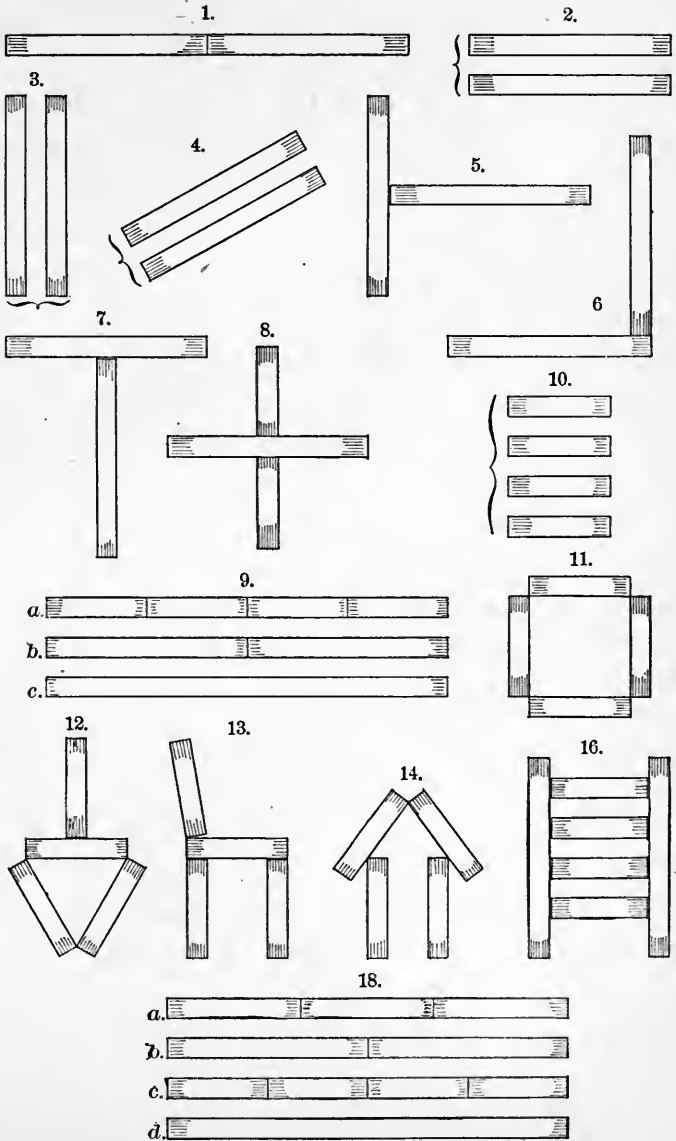

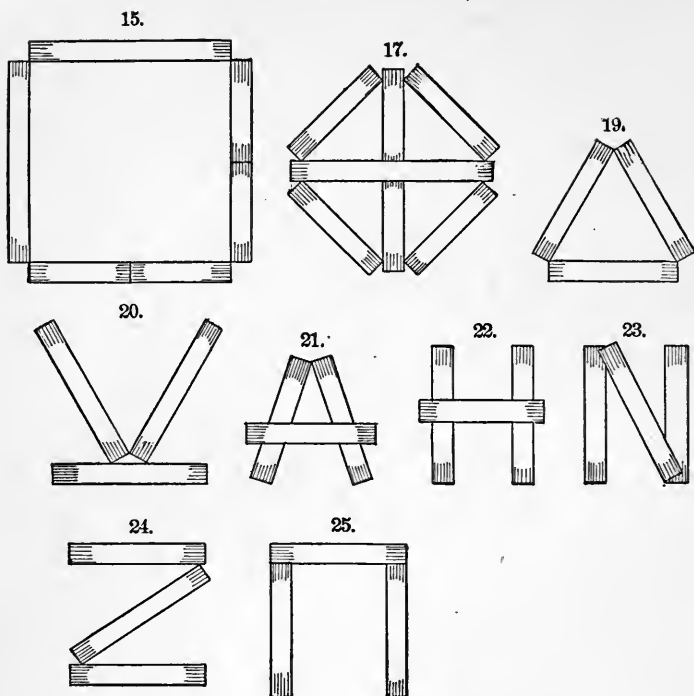

For the exercise with one fourth, suggested in Figs. 9-14, attention should be paid to the colors of the strips: the three strips, *a*, *b*, *c*, in Fig. 9, should be of different colors. These color contrasts will make the fraction contrasts more impressive.

In Figs. 15, 16, and 17, exercises for still further contrasting halves and fourths are suggested. In Fig. 15, the equivalence of

one (red) half and two (blue) fourths is quite prominent.

Fig. 18 contrasts thirds, halves, and fourths, and Figs. 19-25 suggest re-arrangements of thirds.

Dictations are quite helpful here in bringing numerical relations into prominence. Thus, for Fig. 11: "Lay two fourths parallel from right to left, five inches apart; lay the other two fourths between their ends, from front to back, five inches apart, making a square."—This dictation contains and conveys the formula $\frac{2}{4} + \frac{2}{4} = 1$. The same formula lies in Fig. 14.

In Figs. 12 and 13, lies the formula $\frac{3}{4} + \frac{1}{4} = 1$.

Figs. 20-25, by the similar positions (parallel or diverging) of two thirds and the clear contrast in position of the remaining third, say clearly $\frac{2}{3} + \frac{1}{3} = 1$.

These hints will suffice to show the educational value of the fraction strip, and to enable the reader to use it effectively, in the limits indicated above, in the development of clear notions concerning the relations of fractions to the whole and to each other.

The wide (one inch) fraction strip, pre-

pared as an intertwining strip, will be found very serviceable in the development of ideas of position and form. More particularly for the former, I have found it invaluable. It is prepared as follows: "Lay the strip before you from right to left (Fig. *a*), fold the upper third, lengthwise, on the remainder of the strip, and crease carefully in the fold (Fig. *b*); fold the front third lengthwise on the upper third and crease carefully in the fold (Fig. *c*).

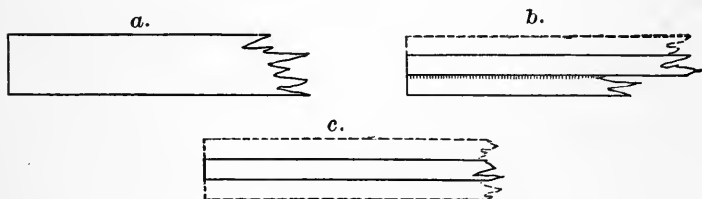

It may be necessary to assist a number of children the first time in making these somewhat difficult long creases; but they will find the work easy and enjoyable after this.

For exercises in positions, the children, by dictation, hold the strips well stretched between their hands, "horizontal, vertical, slanting (to the right, left, back, etc.), parallel to the front edge of the desk, perpen-

dicular and oblique to it (or to some other line or plane), from North to South, from East to West," etc. The interest of exercises in relative positions will be still further increased, if children are grouped in sets of two, one of whom has a red and the partner a yellow strip (other color contrasts will answer the same purpose). The red (or yellow) strips are then, by dictation, held parallel, perpendicular, oblique to the yellow (or red) strips, at a variety of distances, points, and angles.

The subjoined figures (1-7) may suffice to indicate how the intertwining strips may be used for exercises with angles (right, obtuse, and acute), as well as for the making of given geometrical forms. At the points, marked *m*, one end of the strip is inserted between the folds of the other end.

Thus Fig. 1 is a right angle which, by dictation, may be held in a variety of positions, or may be united with the right angles of neighbors into a variety of forms. Or, it may be used to represent a carpenter's square, the letter L, a tent, etc. Fig. 2 is a square, a picture-frame, a window, an inclosed well, etc.

1.

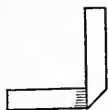

2.

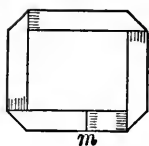

3.

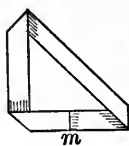

4.

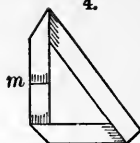

5.

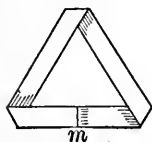

6.

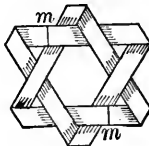

7.

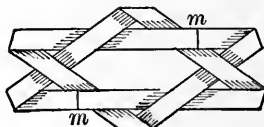

CHAPTER XVI.

SPLINTS OR STICKS.

SQUARE match splints, cut of the required lengths, offer a remarkably cheap and serviceable material for form and number studies, as well as for drawing exercises. They can be had from dealers in lengths of one to five inches. Where this is impracticable, pieces of straw, strips of card-board, or tooth-picks, appropriately cut, will answer the purpose quite well.

In a short chapter, it is possible only to indicate the wealth and flexibility of this material in school work. For this purpose, a few typical lessons have been sketched below. The first series is devoted to lessons in the rudiments of form.

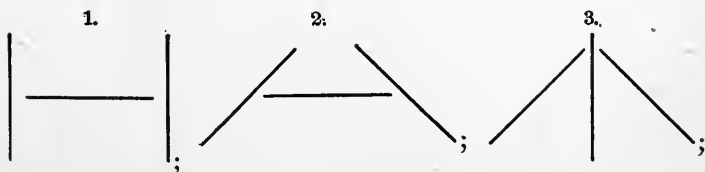

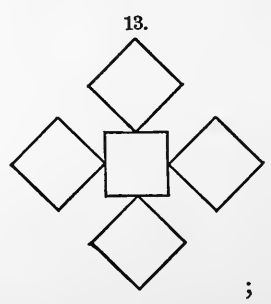
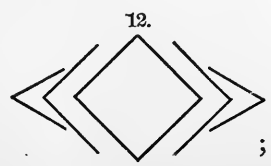
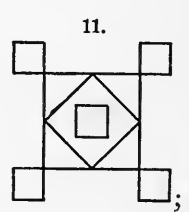
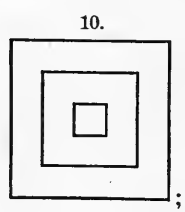
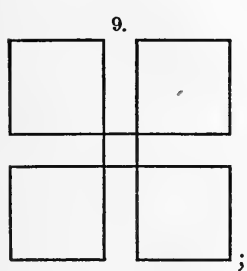
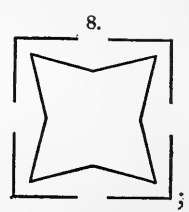
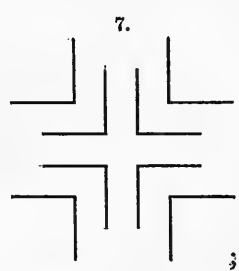
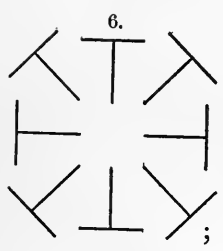
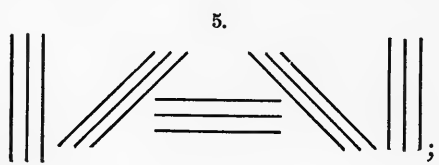

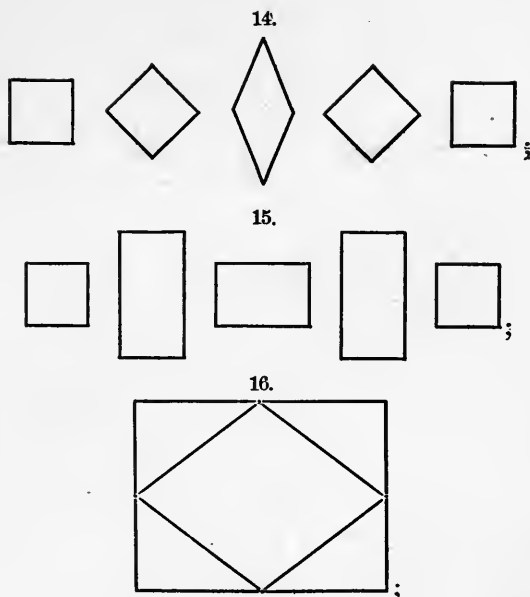

Figs. 1-4 indicate exercises for position, actual or symbolic (as in drawing from objects). Each child receives a supply (9-12) of splints, four inches long, with which he works, at first by dictation, and afterward independently, as follows (Fig. 1):

“Lay six sticks near your right hand, and six sticks near your left hand.—With the right hand, lay one stick (eight inches behind the edge of the desk) from right to left.—With the left hand lay one stick one inch to the left of this, from front to back;

with the right hand, lay a third stick from front to back, one inch to the right of the first stick." Questions may now be asked, to fix the contrasted ideas: "How many sticks from front to back? from right to left? Where is the stick from right to left? Where are the sticks from front to back?" The children may then be permitted to make a number of similar "forms" or "drawings" with the remaining sticks; and, subsequently, to imitate these on the slate, the paper, or the blackboard.

Or we may dictate as follows (Fig. 2): "I see" (the children laying on the desks the forms described) "nine inches from the desk front, near the middle of the desk, a straight line from right to left; right and left of this I see two straight lines slanting inward and backward."

Or (Fig. 4), using the symbolic terms, horizontal for "from right to left," vertical for "from front to back," etc.—we may say: "Draw with one stick, near the middle of the desk, a vertical line; draw right and left of the vertical two horizontal lines; draw right and left of these lines slanting inward at the top."

Similarly, Fig. 5 teaches parallelism in different positions; Fig. 6, the perpendicular relation in a variety of positions; Fig. 7, the right angle; Fig. 8 contrasts right obtuse and acute angles; Fig. 12 right and acute angles; Figs. 9, 10, 11, 13 present studies of the square in varieties of shape and position; Fig. 14 contrasts the square and lozenge; Fig. 15, the square and oblong rectangle; Fig. 16, the lozenge and oblong rectangle.

It is scarcely necessary to add that in these and similar ways the child may learn to control the form relations of all the various polygons, and to apply the knowledge obtained in drawing and other pursuits. This is partly indicated in the following nine "star forms:"

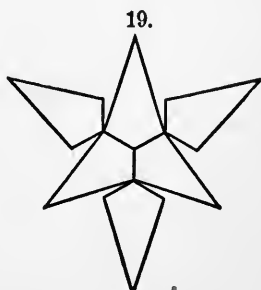
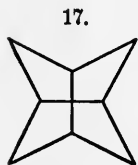

20.



21.

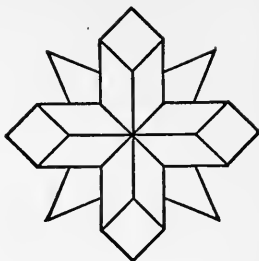

22.

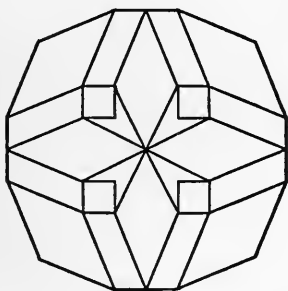

23.

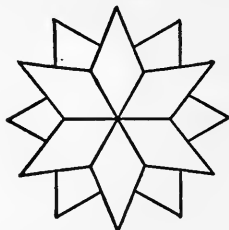

24.

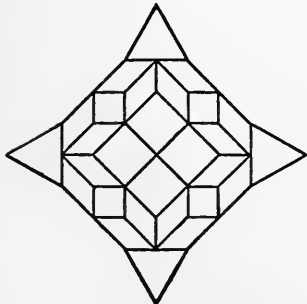

25.

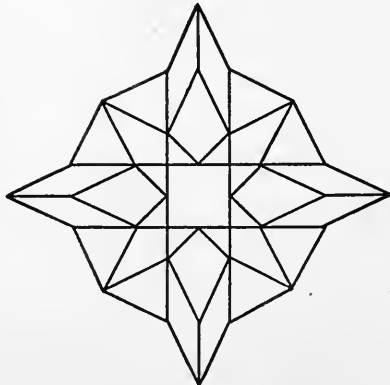

Figs. 17, 18, and 19 apply the trapezium; Fig. 20, the lozenge; Fig. 21, the rhomboid, square, and trapezium; Fig. 22, the trapezium, square, rhomboid, lozenge, and dodecagon; Fig. 23, trapezium with hexagon and dodecagon, etc. Star-forms and other symmetrical forms may thus be "drawn with the splints," and, subsequently, on slate or paper.

Similar devices will help the children to gain self-confidence even in object-drawing, inasmuch as even moderate skill will find it easy to lay or "*draw with splints*" skeleton sketches of houses, barns, fences, trees, pieces of furniture, etc. My "Primary Helps" contains an abundance of hints in this direction.

Teachers will find match splints very useful, too, in the rudiments of arithmetic. The analysis and synthesis of numbers, addition, subtraction, multiplication, division, and part-taking are performed readily in an endless variety of interesting exercises with the help of splints. For such exercises I have found the two-inch splint most convenient, although others may be used profitably enough. The following cut sug-

gests a simple mode of using these for exercises in the limits of 1-10.

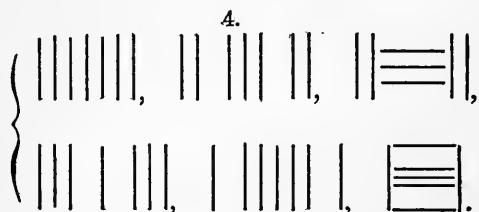
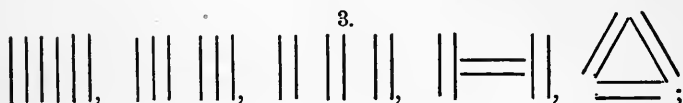
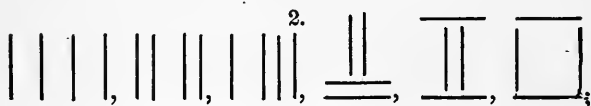
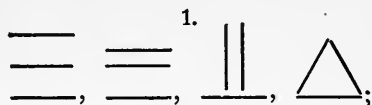

In the first series (Series 1) the number *three* comes to the child, successively, as three ones, two and one, one and two, one three. In the first figure of the series, the three sticks lie in the same direction at great one-inch intervals; to the child nothing unites them, they are distinctly three ones. In the second figure of the series, the upper two sticks are more closely associated as a *pair* or a *two* by their greater closeness. In

the third figure, this association of the two is strengthened or intensified by the additional uniting contrast of position. In the last figure, the three sticks are closely associated in a *three*, "one three," by the triangle they inclose.

Similar considerations will reveal in Series 2 the following number-readings for the little learner: $4(1) = 4$, $2(2) = 4$, $1 + 3 = 4$, $2 + 2 = 4$, $2 + 2(1) = 4$, $4 = 4$.—In Series 3 we have: $6(1)$, $2(3)$, $3(2)$, $2(2) + 1(2)$, and $3(2)$ more closely associated into a six with the help of the inclosed triangle.—In Series 4 we have: $7(1)$, $2(2) + 1(3)$, or (with the help of previous knowledge), $4 + 3$, $2(2) + 1(3)$, $2(3) + 1$, $2(1) + 5$, $4 + 3$.

By making bundles of sticks, ten in each, similar exercises may be contrived for work within even higher limits (1-100).

A very profitable combination of form and number exercises is illustrated in the following figures:

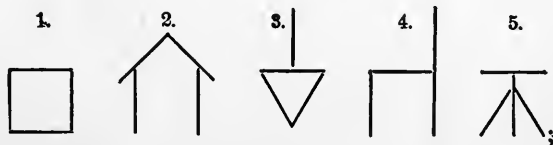

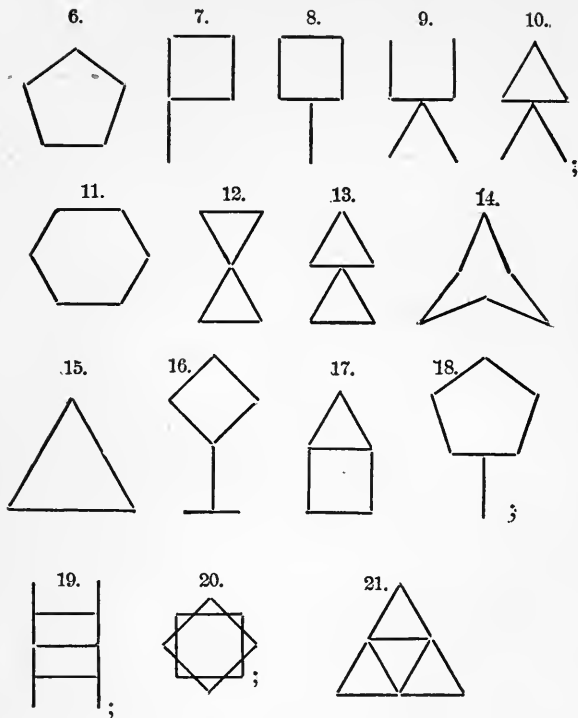

Figs. 1-5 show the four sticks, numerically, as 4, 2(2), 3 + 1, 3 + 1, 3 + 1. As suggestions for form concepts and drawing exercises, they represent to the child, successively, a box or picture, a house or shed, a trowel or spade, a chair, a table. The remainder of the table treats the numbers five, six, etc., in a similar way.

CHAPTER XVII.

STICKS AND PEAS.

FOR this occupation the ordinary match splints may be sharpened at the ends, or a special kind of sticks about the thickness of stout broom-straws may be procured from a dealer in kindergarten goods.* Dried peas, soaked over night in water, serve as a cement to bind these sticks together. If the forms are to be made more permanent, the ends of the sticks may be dipped in mucilage before insertion into the peas. For advanced children, small pellets of bees-wax about the size of peas answer an excellent purpose.

It will be seen from an examination of the illustrations given below that the peas represent points, and the lines mark the distances between them; also that the surfaces inclosed by these lines—as well as the

* These thin sticks come five and ten inches long, and may be cut with scissors of any required length within these limits.

solids inclosed by the surfaces—represent comparatively pure form-concepts quite free from any admixture of materialness.

The cuts show the growth and analysis of the square, the growth and study of the cube, the bisection and trisection of the right angle, the test of the latter with the help of the equilateral triangle and hexagon, and a few typical regular solids or crystal forms.

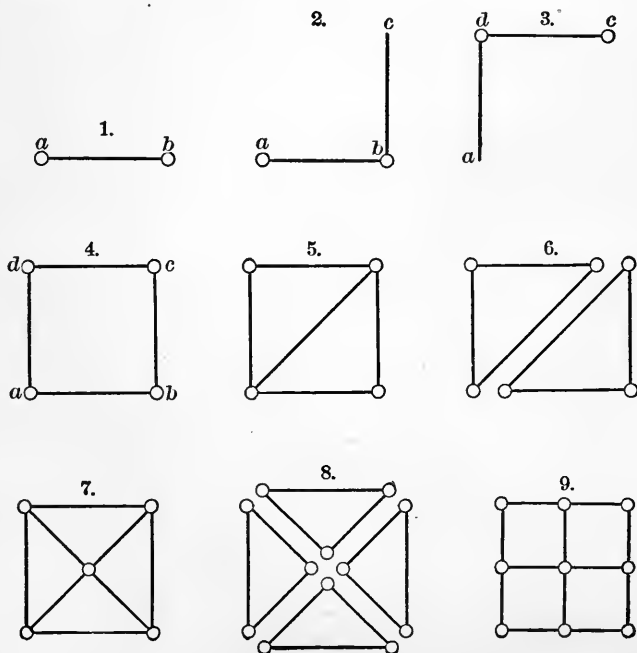

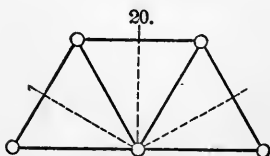
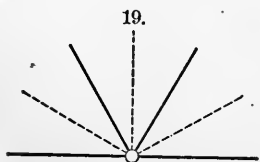
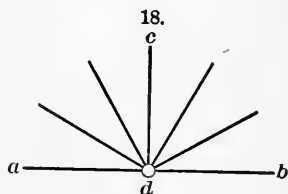
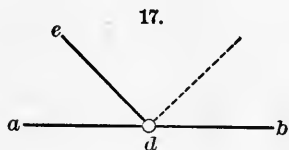
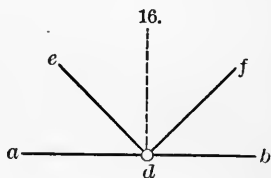
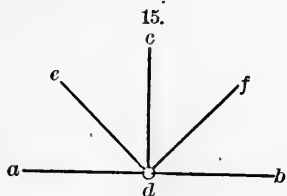
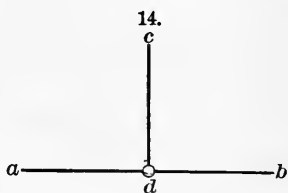
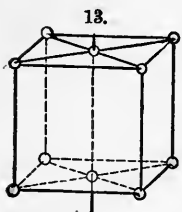
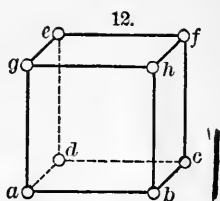
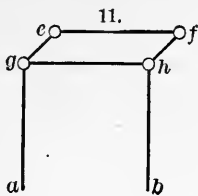
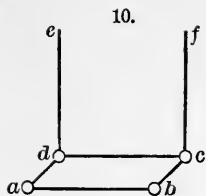

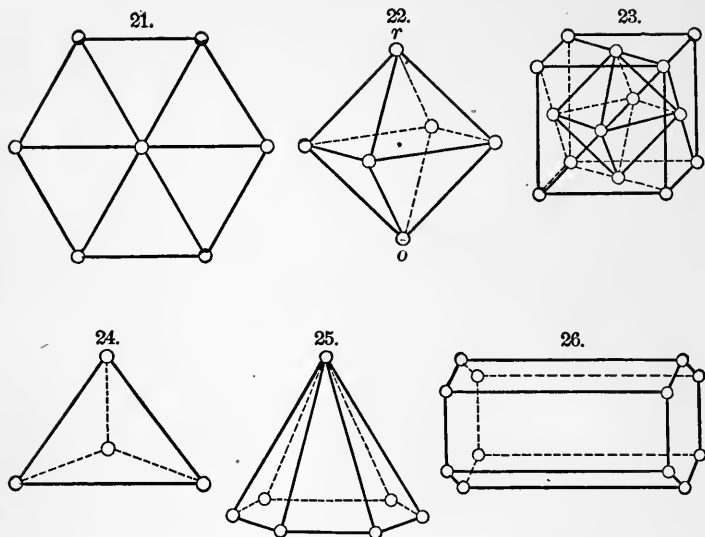

For Fig. 1—a straight line—the pupils hold the stick between thumb and forefinger of the right hand, quite near the left end of the stick, and insert the point of the latter in the pea, held between thumb and forefinger of the left hand. The same is done on the right end of the stick, the latter being held between the thumb and forefinger of the left hand, and the pea in the right hand.

For Fig. 2—two lines, forming a right angle—the stick *ab* is held with the left hand, the pea *b* being specially supported,

and the stick bc is inserted with the right hand. For Fig. 3, the hands change office.

For Fig. 4—the square—Fig. 2 is laid to the right and in front of Fig. 3; the free end c of Fig. 2 is inserted in pea c of Fig. 3, and the free end a of Fig. 3 is inserted in the pea a of Fig. 2.

Fig. 5 shows the first step in the analysis of the square, the “drawing” of a diagonal; Fig. 6, the separation by the diagonal into two equal, right, isosceles triangles.—In Fig. 7 the two diagonals are drawn. (For this purpose four sticks of the length of half a diagonal may be used, all inserted in the pea at the center; or a pea may be slipped to the middle of the first *whole* diagonal, and the second diagonal may be made from two halves.)—In Fig. 7 the square is broken up by the two diagonals into four equal, right, isosceles triangles.—Fig. 9 indicates a first step for analyzing the square by two diameters.

For the cube, two squares are made ($abcd$ in Fig. 10); in the two ends of one side of each of these, perpendiculars (de and cf) are inserted; one of these forms is then inverted, bringing the square to the top, and

the perpendiculars forward; this is lifted over and in front of the other, and the cube (Fig. 12) completed.

Fig. 13 shows the insertion of an axis of the cube. The diagonals in the upper and lower faces simply furnish points of support for the axis.

Figs. 14-17 illustrate exercises for bisecting the right angle. In Fig. 14, the right angle is established on both sides of the stick dc ; in Fig. 15, it is bisected on the right by stick df , on the left by stick de ; in Fig. 16, the removal of the stick dc reveals the right angle formed by the bisecting sticks df and de ; in Fig. 17, the removal of df brings out the contrast between the miter (45°) and the sum of the right angle and miter (135°).

Fig. 18 shows the trisection of the right angle on the two sides of the perpendicular dc . In Fig. 19, the removal of alternate sticks gives three angles of 60° . In Fig. 20, this is verified by the insertion of sticks of the same length between the outer or free ends of the radiating sticks. If the trisection is correct, this will give three equilateral triangles or one half of the hex-

agon, completed in Fig. 21.—Similarly treated, Fig. 15 will yield an octagon, and Fig. 18 a dodecagon.

The building of the octahedron (Fig. 22) begins with the laying of the square. On each side of this four equilateral triangles are erected, meeting in the common points *o* and *r*. Fig. 23 solves an interesting "puzzle," the building of the octahedron in the cube; the diagonals laid across the sides of the square merely hold the peas or wax pellets that represent the corners of the octahedron. Fig. 24 shows the tetrahedron, bounded by four equilateral triangles; the six-sided pyramid and the six-sided prism. Similarly other forms may be treated.

These skeleton models or outlines of forms may be used very profitably in the study of form and in drawing, more particularly in all kinds of perspective drawing. In the study of the propositions and problems of plane and solid geometry, as well as in the study of the rudiments of crystallography, the sticks and wax pellets furnish, even in advanced classes, a more convenient and more efficient aid than the drawing surface of paper or blackboard.

Whenever dictation is used in these exercises, it is essential for orderly success that the children should arrange their material similarly (*e. g.* the sticks to be used on the right side of the table or desk, and the peas in a neat paper box or other receptacle on the left side); and that all the work be done strictly in accordance with the teacher's directions, slowly and deliberately. On the other hand, full freedom in handling the material should be granted in independent work.

CHAPTER XVIII.

LENTILS OR DOTS.

AMONG us the lentil seed is rarely planted. It is quite largely imported, however, by German grocers, who sell it at very reasonable rates. Froebel found in this flat, smooth, circular seed a most serviceable representative of the *point* or position, as I shall show directly. Other seeds have been proposed—such as beans, peas, wheat, barley, etc.—but had to be abandoned as inadequate. Mrs. Hailmann, therefore, contrived an artificial lentil seed, a circular disk, one fourth inch in diameter, cut from wood. These are furnished white, black, and in the rainbow colors, by Mr. Bradley, at low rates. For primary work, too, he furnishes similar disks cut from gummed paper, which are of great value in form and color exercises, and cost very little. The subjoined plate will suggest the manner in which this most flexible material

may be used in lessons on form. For this purpose I have chosen a somewhat systematic treatment of the square, leaving the reader to devise similar series of exercises for other forms.

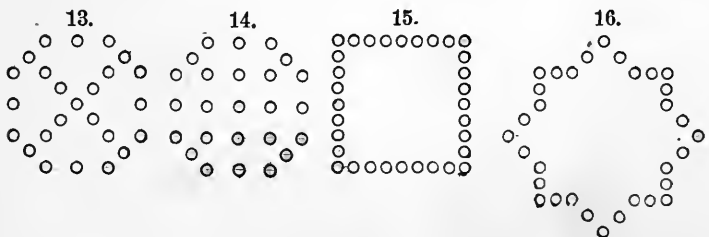
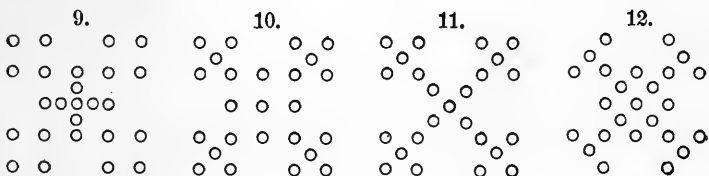
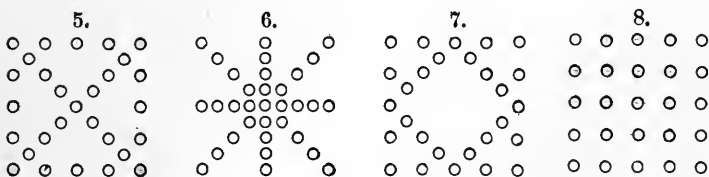
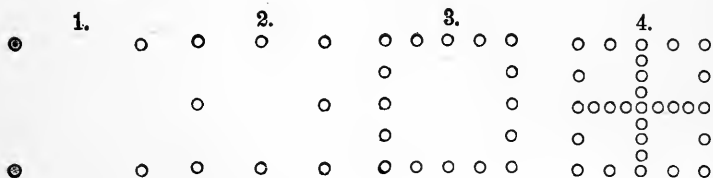

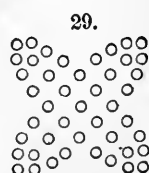
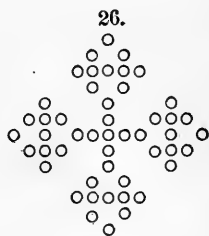
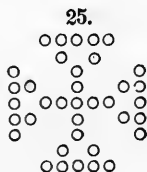
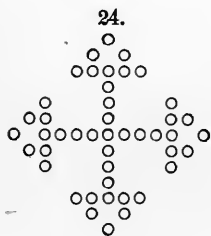
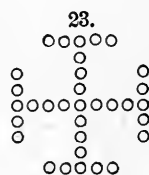
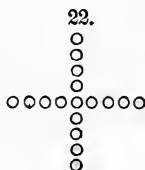
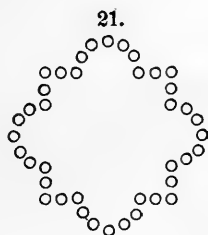
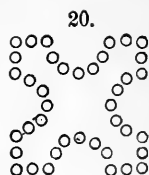
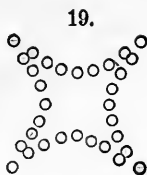
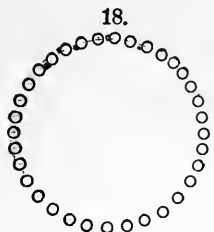
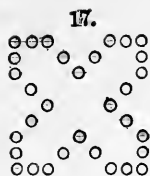

30.

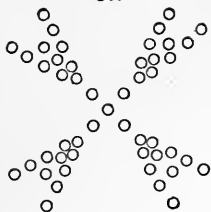

31.

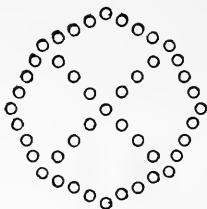

32.

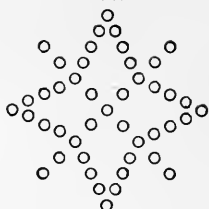

33.



34.

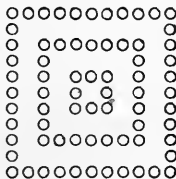

35.

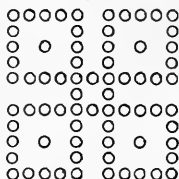

36.



37.



38.

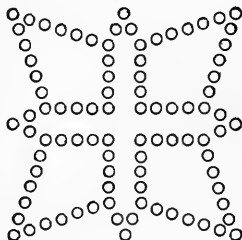

39.

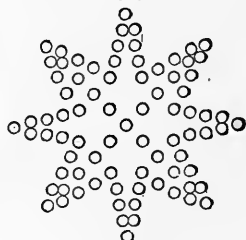

40.

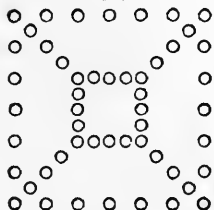

41.

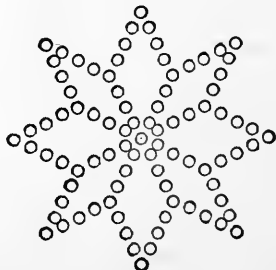

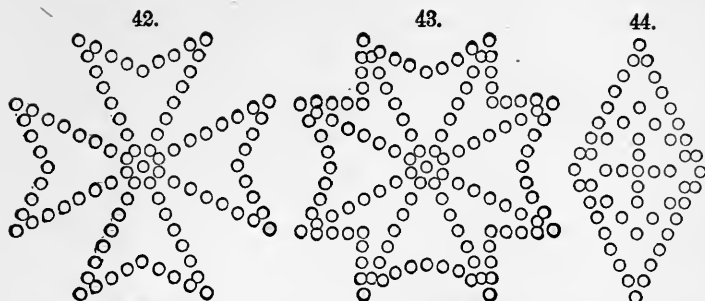

Fig. 1 indicates the square with the help of four dots placed at the corners; its outlines are formed by the distances between successive dots; and the space inclosed in these outlines. Thus, with the exception of the four corners, the square is wholly a mental creation. In Figs. 2 and 3 the sides are respectively bisected and quadrisectioned. In Figs. 4, 5, and 6, the diameters and diagonals are drawn. Fig. 7 shows the four secondary diagonals.

Figs. 8-14 show a series of transformations of the square introduced by Fig. 8. For Fig. 9, the central dot of each side of the square has been moved inward, near the center of the square.—For Fig. 10, the central dot of each side has been placed near one of the corner dots.—The remaining transformations will explain themselves.

Figs. 15-21 show a series of transformations of the outline of the square introduced by Fig. 15.—In Fig. 16, the three middle dots of each side were moved outward.—In Fig. 17, the same three dots were moved inward.—In Fig. 18, the sides of the square curve outward; in Fig. 19, they curve inward.—In Figs. 20 and 21, this curvature is limited to the middle five dots of each side.

Figs. 22-27 show a series of symmetrical patterns built on the two diameters of the square (Fig. 22).

Figs. 28-33 show a similar series of patterns built on the two diagonals of the square (Fig. 28).

The remaining figures will explain themselves sufficiently.

Similar series of exercises may be contrived on the basis of other simple geometrical figures—the equilateral triangle, the circle, the lozenge, the hexagon, etc.

Again, even small children will find it a comparatively easy task to “draw” or *lay* with these dots the outlines of all kinds of objects—houses, trees, pieces of furniture, tools, flowers, animals, etc. I have seen

quite complicated "picture stories" and landscapes drawn with the help of these by children, five to seven years old.

Lately I have learned to use the dots as a most convenient help in experimental arithmetic. A few specimen solutions will illustrate this, and suggest an abundance of useful exercises and ways.

The following examples were given by pupils in a class exercise with children of the third grade, and solved experimentally by the class with the help of dots. Each child had received fifty dots.

(1) John had 25 cents. He lost 3 cents, and spent 15 cents for a book. How many cents had he left?

SOLUTION.—The children first laid down 25 dots, to represent the 25 cents, taking care to lay them by tens, thus: $\begin{array}{l} \circ \circ \circ \circ \circ \circ \circ \circ \circ \circ; \\ \circ \circ \circ \circ \circ \circ \circ \circ \circ \circ; \\ \circ \circ \circ \circ \circ \end{array}$ they then removed three dots for three cents lost, and, lastly, fifteen dots for the 15 cents spent, leaving the remainder thus: $\circ \circ \circ \circ \circ \circ \circ$.

A few children had placed their dots on their slates, and then, without removing

any of them, counted off the required numbers and made marks with their pencils. Thus, in this example, three are counted off, and then fifteen, a vertical mark indicating the steps.

(2) Harry received 12 cents from his father, 9 cents from his mother, his sister gave him 4 cents, and he found 2 cents. How many cents had he in all?

SOLUTIONS: a.

```

○○○○○○○○○○○○
○○
○○○○○○○○○○○○
○○○○
○○
○○

```

b.

```

○○○○○○○○○○○○
○○○○○○○○○○○○
○○○○○○○○○○

```

c (on slates).

```

○○○○○○○○○○○○
○○|○○○○○○○○○○
○|○○○○○|○○

```

(3) How many pencils at 4 cents apiece can Harry buy with his money?

SOLUTIONS: a. ○○○○○○
○○○○○○
○○○○○○
○○○○○○
○○○○○○

b (on slates) ○○○○|○○○○|○○
○○|○○○○|○○○○|
○○○○|○○○

(4) My father gave us 36 pennies. How many did each one of us (four children) get?

SOLUTIONS: a. ○○○○○○○○○○○
○○○○○○○○○○○○
○○○○○○○○○○○○
○○○○○○○○○○○○

b (on slates) ○○○○○○○○○○○
○○○○○○○○○○○○
○○○○○○○○○○○○
○○○○○○○○○○○○

(5) What will $2\frac{1}{2}$ pounds of coffee cost, at 18 cents per pound?

SOLUTIONS: a. $\begin{array}{ccc} \circ \circ \circ \circ \circ \circ \circ \circ \circ \circ & \circ \circ \circ \circ \circ \circ \circ \circ \\ \circ \circ \circ \circ \circ \circ \circ \circ \circ \circ & \circ \circ \circ \circ \circ \circ \circ \circ \\ \circ \circ \circ \circ \circ \circ \circ \circ \circ \circ & \end{array}$

b. $\begin{array}{cccc} \circ \circ \circ \circ \circ \circ \circ \circ \circ \circ & & & \\ \circ \circ \circ \circ \circ \circ \circ \circ \circ \circ & & & \\ \circ \circ \circ \circ \circ \circ \circ \circ \circ \circ & & & \\ \circ \circ \circ \circ \circ \circ \circ \circ \circ \circ & & & \\ \circ \circ \circ \circ \circ \circ & & & \end{array}$ c. $\begin{array}{cccc} \circ \circ \circ \circ \circ \circ \circ \circ \circ \circ & & & \\ \circ \circ \circ \circ \circ \circ \circ \circ \circ \circ & & & \\ \circ \circ \circ \circ \circ \circ \circ \circ \circ \circ & & & \\ \circ \circ \circ \circ \circ \circ \circ \circ \circ \circ & & & \\ \circ \circ \circ \circ \circ \circ \circ \circ \circ \circ & & & \\ \circ \circ \circ \circ \circ \circ \circ \circ \circ \circ & & & \end{array}$

(6) A grocer mixed one pound of sugar worth 7 cents, one pound of sugar worth 8 cents, and one pound of sugar worth 12 cents. How much is one pound of the mixture worth? (This problem was given by the teacher.)

SOLUTIONS: a. $\begin{array}{cccc} \circ \circ \circ \circ \circ \circ \circ \circ \circ \circ & & & \\ \circ \circ \circ \circ \circ \circ \circ \circ \circ \circ & & & \\ \circ \circ \circ \circ \circ \circ \circ \circ \circ \circ & & & \end{array}$ b. $\begin{array}{cccc} \circ \circ \circ \circ \circ \circ \circ \circ \circ \circ & & & \\ \circ \circ \circ \circ \circ \circ \circ \circ \circ \circ & & & \\ \circ \circ \circ \circ \circ \circ \circ \circ \circ \circ & & & \end{array}$

[In (a) the child counted from top to bottom beginning on the left, successively 7, 8, 12; in (b) he laid in the first horizontal row 7, in the second 8, in the third 8; then filled up the rows with the remaining 4.]

(7) How many dozen in 50 eggs?

SOLUTIONS: a. $\begin{array}{ccc} \circ \circ \circ \circ \circ \circ \circ \circ \circ \circ & \circ \circ & \\ \circ \circ \circ \circ \circ \circ \circ \circ \circ \circ & \circ \circ & \\ \circ \circ \circ \circ \circ \circ \circ \circ \circ \circ & \circ \circ & \\ \circ \circ \circ \circ \circ \circ \circ \circ \circ \circ & \circ \circ & \\ & \circ \circ & \end{array}$ b. $\begin{array}{ccc} \circ \circ \circ \circ \circ \circ \circ \circ \circ \circ & & \\ \circ \circ & & \\ \circ \circ \circ \circ \circ \circ \circ \circ \circ \circ & & \\ \circ \circ & & \\ \circ \circ \circ \circ \circ \circ \circ \circ \circ \circ & & \\ \circ \circ & & \\ \circ \circ \circ \circ \circ \circ \circ \circ \circ \circ & & \\ \circ \circ & & \\ \circ \circ & & \end{array} \circ \circ$

(8) How many quarts of milk in $8\frac{1}{2}$ gallons?

SOLUTIONS:

a.

○○○○ ○○○○
 ○○○○ ○○○○
 ○○○○ ○○○○
 ○○○○ ○○○○
 ○○

b.

○○○○ ○○○○ ○○○○ ○○○○ ○○○○
 ○○○○ ○○○○ ○○○○ ○○

(9) A man sold 5 cows, and gained 45 dollars. How much did he make on each cow?

SOLUTION: ○○○○○○○○○○
○○○○○○○○○○
○○○○○○○○○○
○○○○○○○○○○
 ○○○○○○○○○○

CHAPTER XIX.

THE GROUP TABLE.

THE group table is a modified kindergarten table, adapted to the requirements of social work with the material described in this volume, as well as with other occupation material. The table I now use at La Porte is thirty inches square and twenty-two inches high. The top is ruled in square inches, like the ordinary kindergarten table. The center is marked in some convenient way. When it is in use, four children are seated around it on low chairs or stools; each child sitting in front of the middle of one of the sides. In the exercises, each child represents the side before it or the corner on the right or left, so that with its help a kind of rhythmic life is imparted to the square.

A few typical exercises will best illustrate its use.

In Fig. 1, the outline of the large square

represents the edges of the group table. The children are seated in front of the points *a*, *b*, *c*, and *d*. The center of the table is marked with a cross (X). Each child has received for work twelve cubical blocks which he has placed (by direction) in a row from right to left two inches behind the edge of the table. For my convenience in the description of the following exercises, I have marked the cubes in the diagram with the figures 1-6 from both ends of the row.

The diagram presents two exercises: the first near the margin, the second around the center of the diagram. For the first exercise the two central blocks (6, 6) of the original row remain stationary. The remainder are moved by the children in accordance with the following dictation, by the teacher or by an older pupil: "With the right hand move the five cubes on the right back one inch;—with the left hand the five cubes on the left back one inch.—With the left hand move the four cubes on the left back one inch;—with the right hand the four on the right back one inch.—With the right hand move the three cubes on the right back one inch;—with

the left hand the three cubes on the left back one inch.—With both hands move the two cubes on the left and the two on the right back one inch.—With both hands move one cube on the left and one on the right back one inch.” At each symmetric phase—indicated in the dictation by a period and dash—the teacher should pause to give the children an opportunity for observing the social or group value of the form obtained.

For the second exercise—indicated in the central form—the following dictation is in place: “With both hands move the outside blocks (1) inward (each) five inches,—back six inches.—With both hands move the next outside blocks (2) inward three inches,—backward six inches.—With both hands move the next outside cubes (3) inward one inch,—backward six inches.—With both hands move the next outside cubes (4) inward one inch,—backward six inches.—With both hands move the next outside cubes (5) backward six inches,—inward one inch. With both hands move the last blocks backward six inches.”

Here again it is desirable that the teacher

should pause at each symmetric phase to give the children an opportunity to observe *their* work. The influence of this work on the social instincts of the children is ob-

FIG. 1.

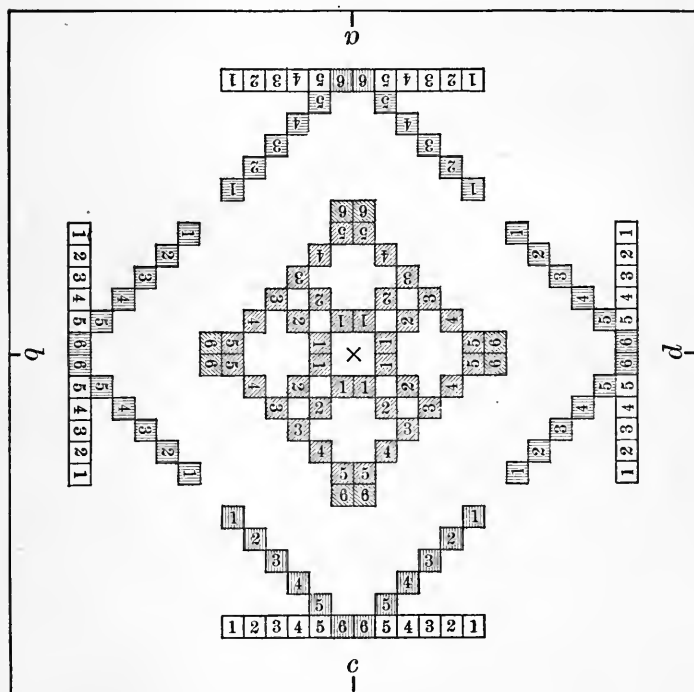

vious. However much each one may at the beginning be interested in *his* own cubes, this individual ownership is soon lost sight of in the joy of the common work, in the

results of "our" work. I have never yet found a child that had the hardihood to claim his share of the material as his own, after completion of the group form.

FIG. 2.

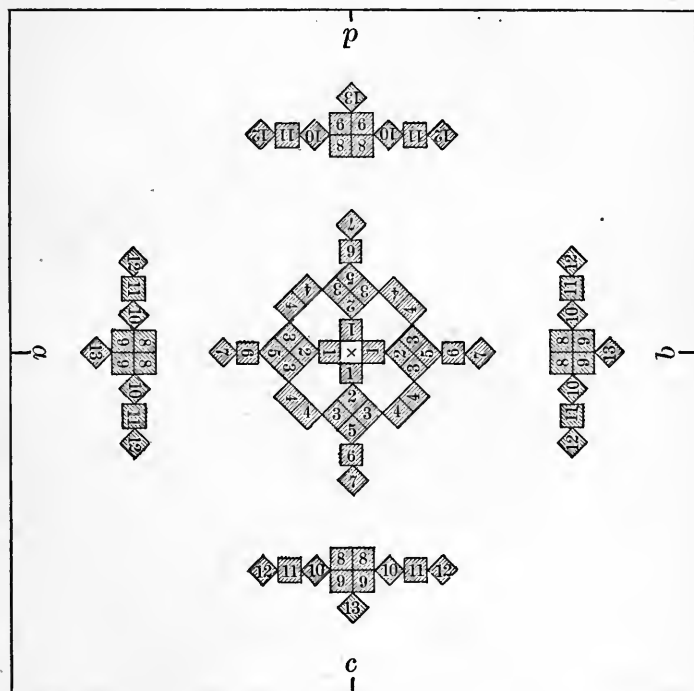

In Fig. 2, I have represented the result of the joint invention of a group of four children in the second grade of a primary school. Each child had received twenty

cubes ("four fives," as the teacher said). The teacher had indicated the center of the table by placing a cube in the spot indicated by a cross (x) in our figure, and then

FIG. 3.

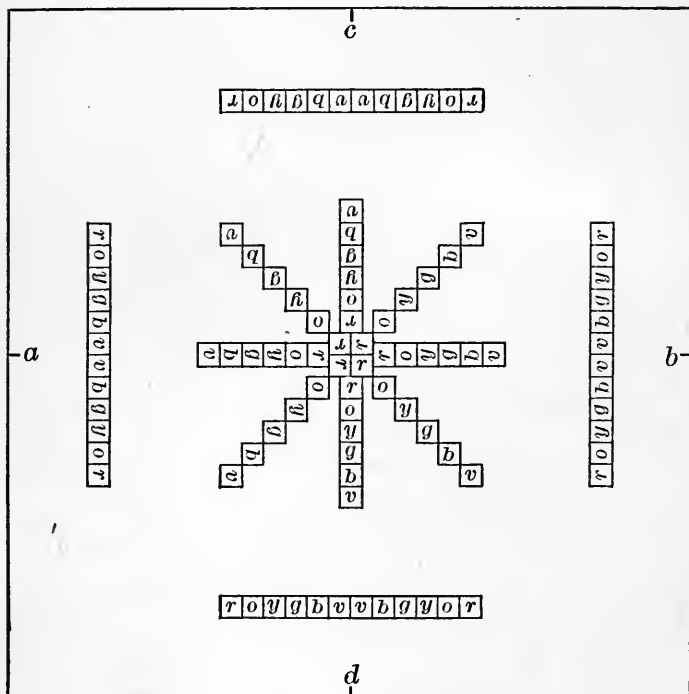

left the children to the rule of their "game" of *Follow the leader*. This rule is simple. One of the children (a) begins, places a block (in this case [1]). He is followed in the

same movement by the child on the opposite side (*b*), and this one is followed by the remaining children (*c* and *d*), who place the corresponding blocks simultaneously. The next move (2) is originated by the

FIG. 4.

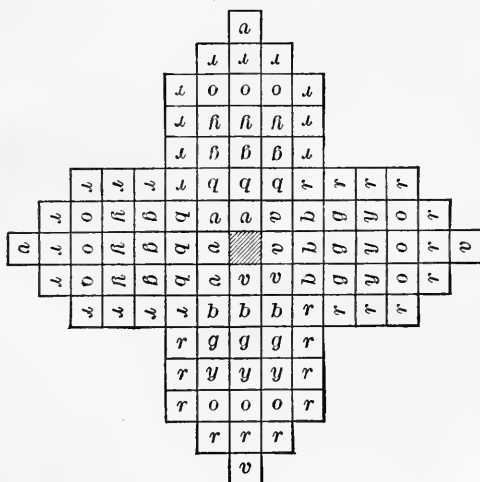

child (*b*), the third move (3) by the child (*c*), the next (4) by the child (*d*). Then it is again (*a*)'s turn, and the game continues until the material is exhausted.

Here both the conception and the work are common, belong not to any individual child, but to the group as a whole. The pattern is a common *finding* or invention,

drawing in its growth equally on the powers of all the children.

Figs. 3 and 4 are illustrations of color exercises with the aid of colored cubes. Fig. 3 is a dictation exercise in the rainbow

FIG. 5.

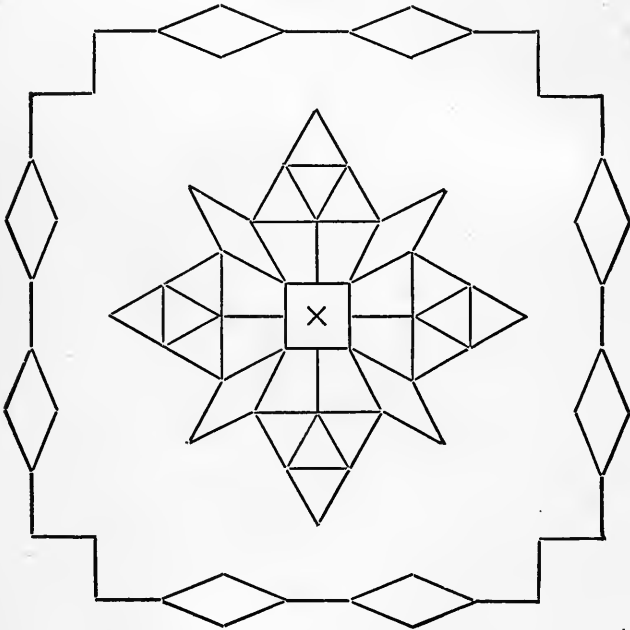

colors. The pupils have received twelve blocks, two of each of the six colors. By dictation, these are placed in a certain order—here indicated by the initial letters of the color names—from left to right, ready for

use. The central figure results from suitable dictation for moving the cubes inward. Fig. 4 is an invention of the group of children.

Figs. 5 and 6 present similar suggestions

FIG. 6.

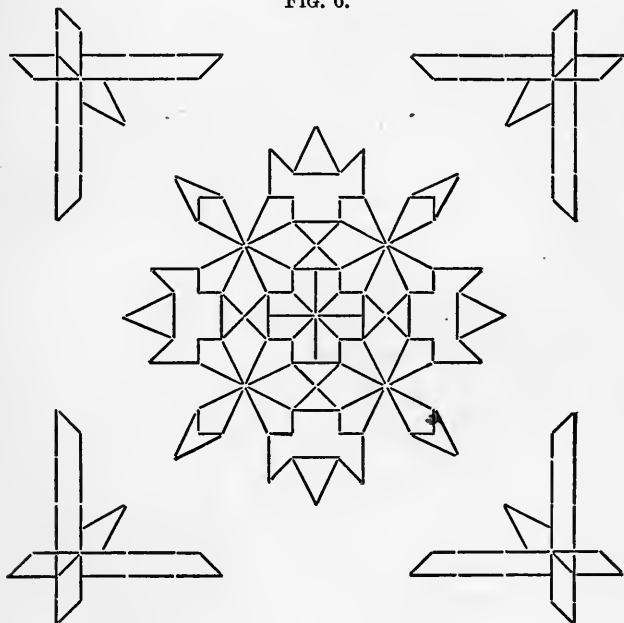

with sticks or splints. In Fig. 5 two-inch sticks—plain or colored—are used for a dictation. Fig. 6 reports the invention of a group of children with the help of one-inch and two-inch sticks.

These suggestions must suffice. The gain from these exercises in the development of social virtue constitute their chief value. The fact that the union of the group in aim and effort is essential to success is so prominent that a distinct group consciousness is born which makes the four peculiarly and distinctly one. On the other hand, the importance of each member of the group as an indispensable part thereof is so obvious, that both self-esteem and social esteem grow apace but in healthy union, one aiding the other. Thus the child is protected equally against the one-sided excrescences of self-conceit and self-abasement, and gains equally in individual and social vigor. The child is distinctly conscious that by this co-ordination and inordination in a union with equals, self is lifted into a higher order of being, and eagerly gives all he has and is to the purposes of the little group.



GENERAL HISTORY.

Monteith's Youth's History of the United States.

A History of the United States for beginners. It is arranged upon the catechetical plan, with illustrative maps and engravings, review questions, dates in parentheses (that their study may be optional with the younger class of learners), and interesting biographical sketches of all persons who have been prominently identified with the history of our country.

Willard's United States. School and University Editions.

The plan of this standard work is chronologically exhibited in front of the titlepage. The maps and sketches are found useful assistants to the memory; and dates, usually so difficult to remember, are so systematically arranged as in a great degree to obviate the difficulty. Candor, impartiality, and accuracy are the distinguishing features of the narrative portion.

Willard's Universal History. New Edition.

The most valuable features of the "United States" are reproduced in this. The peculiarities of the work are its great conciseness and the prominence given to the chronological order of events. The margin marks each successive era with great distinctness, so that the pupil retains not only the event but its time, and thus fixes the order of history firmly and usefully in his mind. Mrs. Willard's books are constantly revised, and at all times written up to embrace important historical events of recent date. Professor Arthur Gilman has edited the last twenty-five years to 1882.

Lancaster's English History.

By the Master of the Stoughton Grammar School, Boston. The most practical of the "brief books." Though short, it is not a bare and uninteresting outline, but contains enough of explanation and detail to make intelligible the *cause and effect* of events. Their relations to the history and development of the American people is made specially prominent.

Willis's Historical Reader.

Being Collier's Great Events of History adapted to American schools. This rare epitome of general history, remarkable for its charming style and judicious selection of events on which the destinies of nations have turned, has been skilfully manipulated by Professor Willis, with as few changes as would bring the United States into its proper position in the historical perspective. As reader or text-book it has few equals and no superior.

Berard's History of England.

By an authoress well known for the success of her History of the United States. The social life of the English people is felicitously interwoven, as in fact, with the civil and military transactions of the realm.

Ricord's History of Rome.

Possesses the charm of an attractive romance. The fables with which this history abounds are introduced in such a way as not to deceive the inexperienced, while adding materially to the value of the work as a reliable index to the character and institutions, as well as the history of the Roman people.

Hanna's Bible History.

The only compendium of Bible narrative which affords a connected and chronological view of the important events there recorded, divested of all superfluous detail.

Summary of History; American, French, and English.

A well-proportioned outline of leading events, condensing the substance of the more extensive text-books in common use into a series of statements so brief, that every word may be committed to memory, and yet so comprehensive that it presents an accurate though general view of the whole continuous life of nations.

Marsh's Ecclesiastical History.

Affording the History of the Church in all ages, with accounts of the pagan world during the biblical periods, and the character, rise, and progress of all religions, as well as the various sects of the worshippers of Christ. The work is entirely non-sectarian, though strictly catholic. A separate volume contains carefully prepared questions for class use.

Mill's History of the Ancient Hebrews.

With valuable Chronological Charts, prepared by Professor Edwards of N. Y. This is a succinct account of the chosen people of God to the time of the destruction of Jerusalem. Complete in one volume.

Topical History Chart Book.

By Miss Ida P. Whitcomb. To be used in connection with *any History, Ancient or Modern*, instead of the ordinary blank book for summary. It embodies the names of *contemporary rulers* from the earliest to the present time, with blanks under each, in which the pupil may write the summary of the life of the ruler.

Gilman's First Steps in General History.

A "suggestive outline" of rare compactness. Each country is treated by itself, and the United States receive special attention. Frequent maps, contemporary events in tables, references to standard works for fuller details, and a minute Index constitute the "Illustrative Apparatus." From no other work that we know of can so succinct a view of the world's history be obtained. Considering the necessary limitation of space, the style is surprisingly vivid, and at times even ornate. In all respects a charming, though not the less practical, text-book.

Baker's Brief History of Texas.

Dimitry's History of Louisiana.

Alison's Napoleon First.

The history of Europe from 1788 to 1815. By Archibald Alison. Abridged by Edward S. Gould. One vol., 8vo, with appendix, questions, and maps. 550 pages.

Lord's Points of History.

The salient points in the history of the world arranged catechetically for class use or for review and examination of teacher or pupil. By John Lord, LL.D. 12mo, 300 pages.

Carrington's Battle Maps and Charts of the American Revolution.

Topographical Maps and Chronological Charts of every battle, with 3 steel portraits of Washington. 8vo, cloth.

Condit's History of the English Bible.

For theological and historical students this book has an intrinsic value. It gives the history of all the English translations down to the present time, together with a careful review of their influence upon English literature and language.

DRAWING.

BARNES'S POPULAR DRAWING SERIES.

Based upon the experience of the most successful teachers of drawing in the United States.

The Primary Course, consisting of a manual, ten cards, and three primary drawing books, A, B, and C.

Intermediate Course. Four numbers and a manual.

Advanced Course. Four numbers and a manual.

Instrumental Course. Four numbers and a manual.

The Intermediate, Advanced, and Instrumental Courses are furnished either in book or card form at the same prices. The books contain the usual blanks, with the unusual advantage of opening from the pupil, — placing the copy directly in front and above the blank, thus occupying but little desk-room. The cards are in the end more economical than the books, if used in connection with the patent blank folios that accompany this series.

The cards are arranged to be bound (or tied) in the folios and removed at pleasure. The pupil at the end of each number has a complete book, containing only his own work, while the copies are preserved and inserted in another folio ready for use in the next class.

Patent Blank Folios. No. 1. Adapted to Intermediate Course. No. 2. Adapted to Advanced and Instrumental Courses.

ADVANTAGES OF THIS SERIES.

The Plan and Arrangement. — The examples are so arranged that teachers and pupils can see, at a glance, how they are to be treated and where they are to be copied. In this system, copying and designing do not receive all the attention. The plan is broader in its aims, dealing with drawing as a branch of common-school instruction, and giving it a wide educational value.

Correct Methods. — In this system the pupil is led to rely upon himself, and not upon delusive mechanical aids, as printed guide-marks, &c.

One of the principal objects of any good course in freehand drawing is to educate the eye to estimate location, form, and size. A system which weakens the motive or removes the necessity of *thinking* is false in theory and ruinous in practice. The object should be to educate, not cram; to develop the intelligence, not teach tricks.

Artistic Effect. — The beauty of the examples is not destroyed by crowding the pages with useless and badly printed text. The Manuals contain all necessary instruction.

Stages of Development. — Many of the examples are accompanied by diagrams, showing the different stages of development.

Lithographed Examples. — The examples are printed in imitation of pencil drawing (not in hard, black lines) that the pupil's work may resemble them.

One Term's Work. — Each book contains what can be accomplished in an average term, and no more. Thus a pupil *finishes* one book before beginning another.

Quality — not Quantity. — Success in drawing depends upon the amount of *thought* exercised by the pupil, and *not* upon the large number of examples drawn.

Designing. — Elementary design is more skilfully taught in this system than by any other. In addition to the instruction given in the books, the pupil will find printed on the insides of the covers a variety of beautiful patterns.

Enlargement and Reduction. — The practice of enlarging and reducing from copies is not commenced until the pupil is well advanced in the course and therefore better able to cope with this difficult feature in drawing.

Natural Forms. — This is the only course that gives at convenient intervals easy and progressive exercises in the drawing of natural forms.

Economy. — By the patent binding described above, the copies need not be thrown aside when a book is filled out, but are preserved in perfect condition for future use. The blank books, only, will have to be purchased after the first introduction, thus effecting a saving of more than half in the usual cost of drawing-books.

Manuals for Teachers. — The Manuals accompanying this series contain practical instructions for conducting drawing in the class-room, with *definite* directions for drawing *each* of the examples in the books, instructions for designing, model and object drawing, drawing from natural forms, &c.

FAMILIAR SCIENCE.

Norton & Porter's First Book of Science.

Sets forth the principles of Natural Philosophy, Astronomy, Chemistry, Physiology, and Geology, on the catechetical plan for primary classes and beginners.

Chambers's Treasury of Knowledge.

Progressive lessons upon—*first*, common things which lie most immediately around us, and first attract the attention of the young mind; *second*, common objects from the mineral, animal, and vegetable kingdoms, manufactured articles, and miscellaneous substances; *third*, a systematic view of nature under the various sciences. May be used as a reader or text-book.

Monteith's Easy Lessons in Popular Science.

This book combines within its covers more attractive features for the study of science by children than any other book published. It is a reading book, spelling book, composition book, drawing book, geography, history, book on botany, zoölogy, agriculture, manufactures, commerce, and natural philosophy. All these subjects are presented in a simple and effective style, such as would be adopted by a good teacher on an excursion with a class. The class are supposed to be taking excursions, with the help of a large pictorial chart of geography, which can be suspended before them in the school-room. A key of the chart is inserted in every copy of the book. With this book the science of common or familiar things can be taught to beginners.

NATURAL PHILOSOPHY.

Norton's First Book in Natural Philosophy.

Peck's Elements of Mechanics.

A suitable introduction to Bartlett's higher treatises on Mechanical Philosophy, and adequate in itself for a complete academical course.

Bartlett's Analytical Mechanics.

Bartlett's Acoustics and Optics.

A complete system of Collegiate Philosophy, by Prof. W. H. C. Bartlett, of West Point Military Academy.

Steele's Physics.

Peck's Ganot.

GEOLOGY.

Page's Elements of Geology.

A volume of Chambers's Educational Course. Practical, simple, and eminently calculated to make the study interesting.

Steele's Geology.

CHEMISTRY.

Porter's First Book of Chemistry.

Porter's Principles of Chemistry.

The above are widely known as the productions of one of the most eminent scientific men of America. The extreme simplicity in the method of presenting the science, while exhaustively treated, has excited universal commendation.

Gregory's Chemistry (Organic and Inorganic). 2 vols.

The science exhaustively treated. For colleges and medical students.

Steele's Chemistry.

NATURAL SCIENCE—*Continued.*

ASTRONOMY.

Peck's Popular Astronomy.

By Wm. G. Peck, Ph.D., LL.D., Professor of Mathematics, Mechanics, and Astronomy in Columbia College. 12mo. Cloth. 330 pages.

Professor Peck has here produced a scientific work in brief form for colleges, academies, and high schools. Teachers who do not want an elementary work — like Steele's Astronomy, for instance — will find what they want in this book. Its discussion of the Stars, Solar System, Earth, Moon, Sun and Planets, Eclipses, Tides, Calendars, Planets and Satellites, Comets and Meteors, &c., is full and satisfactory. The illustrations are numerous and very carefully engraved, so the student can gain an accurate comprehension of the things represented. Professor Peck is wonderfully clear and concise in his style of writing, and there is nothing redundant or obscure in this work. It is intended for popular as well as class use, and accordingly avoids too great attention to mathematical processes, which are introduced in smaller type than the regular text. For higher schools this astronomy is undoubtedly the best text-book yet published.

Willard's School Astronomy.

By means of clear and attractive illustrations, addressing the eye in many cases by analogies, careful definitions of all necessary technical terms, a careful avoidance of verbiage and unimportant matter, particular attention to analysis, and a general adoption of the simplest methods, Mrs. Willard has made the best and most attractive elementary Astronomy extant.

McIntyre's Astronomy and the Globes.

A complete treatise for intermediate classes. Highly approved.

Bartlett's Spherical Astronomy.

The West Point Course, for advanced classes, with applications to the current wants of Navigation, Geography, and Chronology.

NATURAL HISTORY.

Carll's Child's Book of Natural History.

Illustrating the animal, vegetable, and mineral kingdoms, with application to the arts. For beginners. Beautifully and copiously illustrated.

Anatomical Technology. Wilder & Gage.

As applied to the domestic cat. For the use of students of medicine.

ZOOLOGY.

Chambers's Elements of Zoölogy.

A complete and comprehensive system of Zoölogy, adapted for academic instruction, presenting a systematic view of the animal kingdom as a portion of external nature.

ROADS AND RAILROADS.

Gillespie's Roads and Railroads.

Tenth Edition. Edited by Cady Staley, A.M., C.E. 464 pages. 12mo. Cloth.

This book has long been and still is the standard manual of the principles and practice of Road-making, comprising the location, construction, and improvement of roads (common, macadam, paved, plank, &c.) and railroads. It was compiled by Wm. Gillespie, LL.D., C.E., of Union College.

ÆSTHETICS.

Huntington's Manual of the Fine Arts.

A view of the rise and progress of art in different countries, a brief account of the most eminent masters of art, and an analysis of the principles of art. It is complete in itself, or may precede to advantage the critical work of Lord Kames.

Boyd's Kames's Elements of Criticism.

The best edition of this standard work; without the study of which none may be considered proficient in the science of the perceptions. No other study can be pursued with so marked an effect upon the taste and refinement of the pupil.

ELOCUTION.

Watson's Practical Elocution.

A scientific presentment of accepted principles of elocutionary drill, with black-board diagrams and full collection of examples for class drill. Cloth. 90 pages, 12mo.

Taverner Graham's Reasonable Elocution.

Based upon the belief that true elocution is the right interpretation of thought, and guiding the student to an intelligent appreciation, instead of a merely mechanical knowledge, of its rules.

Zachos's Analytic Elocution.

All departments of elocution—such as the analysis of the voice and the sentence, phonology, rhythm, expression, gesture, &c.—are here arranged for instruction in classes, illustrated by copious examples.

SPEAKERS.

Northend's Little Orator.

Northend's Child's Speaker.

Two little works of the same grade but different selections, containing simple and attractive pieces for children under twelve years of age.

Northend's Young Declaimer.

Northend's National Orator.

Two volumes of prose, poetry, and dialogue, adapted to intermediate and grammar classes respectively.

Northend's Entertaining Dialogues.

Extracts eminently adapted to cultivate the dramatic faculties, as well as entertain.

Oakey's Dialogues and Conversations.

For school exercises and exhibitions, combining useful instruction.

James's Southern Selections, for Reading and Oratory.

Embracing exclusively Southern literature.

Swett's Common School Speaker.

Raymond's Patriotic Speaker.

A superb compilation of modern eloquence and poetry, with original dramatic exercises. Nearly every eminent modern orator is represented.

MIND.

Mahan's Intellectual Philosophy.

The subject exhaustively considered. The author has evinced learning, candor, and independent thinking.

Mahan's Science of Logic.

A profound analysis of the laws of thought. The system possesses the merit of being intelligible and self-consistent. In addition to the author's carefully elaborated views, it embraces results attained by the ablest minds of Great Britain, Germany, and France, in this department.

Boyd's Elements of Logic.

A systematic and philosophic condensation of the subject, fortified with additions from Watts, Abercrombie, Whately, &c.

Watts on the Mind. Edited by Stephen N. Fellows.

The "Improvement of the Mind," by Isaac Watts, is designed as a guide for the attainment of useful knowledge. As a text-book it is unparalleled; and the discipline it affords cannot be too highly esteemed by the educator.

MORALS.

Peabody's Moral Philosophy.

A short course, by the Professor of Christian Morals, Harvard University, for the Freshman class and for high schools.

Butler's Analogy. Hobart's Analysis.

Edited by Prof. Charles E. West, of Brooklyn Heights Seminary. 228 pages. 16mo. Cloth.

Alden's Text-Book of Ethics.

For young pupils. To aid in systematizing the ethical teachings of the Bible, and point out the coincidences between the instructions of the sacred volume and the sound conclusions of reason.

Smith's Elements of Moral Philosophy.

140 pages. 12mo. Cloth. By Wm. Austin Smith, A. M., Ph. D., Professor of Moral Philosophy in the Columbia (Tenn.) Athenæum.

This is an excellent book for the use of academies and schools. It is prepared to meet the wants of a much larger public than has heretofore been reached by works of this class. The subject is presented in clear and simple language, and will be found adapted to the comprehension of young pupils, at a time when they particularly need an insight into the laws which govern the moral world.

Janet's Elements of Morals.

By Paul Janet. Translated by Mrs. Prof. Corson, of Cornell University.

The **Elements of Morals** is one of a series of works chiefly devoted to Ethics, and treats of practical, rather than theoretical morality.

Mr. Janet is too well known that it be necessary to call attention to his excellence as a moral writer, and it will be sufficient to say that what particularly recommends the **Elements of Morals** to educators and students in general is the admirable adaptation of the book to college and school purposes.

Besides the systematic and scholarly arrangement of its parts, it contains series of examples and illustrations — anecdotic, historical — gathered with rare impartiality from both ancient and modern writers, and which impart a peculiar life and interest to the subject.

Another feature of the work is its sound religious basis. Mr. Janet is above all a religious moralist.

FRENCH.

Worman's First French Book.

On same plan as the German and Spanish. The scholar reads and speaks from the first hour understandingly and accurately. 83 pages.

Worman's Second French Book.

Continues the work of the First Book, and is a valuable Elementary French Reader. 96 pages.

Worman's Le Questionnaire.

Exercises on the First French Book. 98 pages. Cloth.

Worman's Grammaire Française.

Written in simple French, but based on English analogy. It therefore dwells upon the *Essentials*, especially those which point out the *variations* of the French from the student's vernacular. 184 pp.

Worman's Teacher's Hand-Book.

Or Key to the Grammaire Française.

Worman's French Echo.

This is not a mass of meaningless and parrot-like phrases thrown together for a tourist's use, to bewilder him when in the presence of a Frenchman.

The "Echo de Paris" is a *strictly progressive conversational book*, beginning with simple phrases and leading by frequent repetition to a mastery of the *idioms* and of the *every-day language* used in business, on travel, at a hotel, in the *clit-chat* of society.

It presupposes an elementary knowledge of the language, such as may be acquired from the First French Book by Professor Worman, and furnishes a *running French text*, allowing the learner of course to find the meaning of the words (in the appended Vocabulary), and forcing him, by the absence of English in the text, to *think in French*.

CHER MONSIEUR WORMAN, — Vous me demandez mon opinion sur votre "Echo de Paris" et quel usage j'en fais. Je ne saurais mieux vous répondre qu'en reproduisant une lettre que j'écrivais dernièrement à un collègue qui était, me disait-il, "bien fatigué de ces insipides livres de dialogues."

"Vous ne connaissez donc pas," lui disais-je, "l'Echo de Paris," édité par le Professor Worman? C'est un véritable trésor, merveilleusement adapté au développement de la conversation familière et pratique, telle qu'on la veut aujourd'hui. Cet excellent livre met successivement en scène, d'une manière vive et intéressante,

toutes les circonstances possibles de la vie ordinaire. Voyez l'immense avantage il vous transporte en France; du premier mot, je m'imaginais, et mes élèves avec moi, que nous sommes à Paris, dans la rue, sur une place, dans une gare, dans un salon, dans une chambre, voire même à la cuisine; je parle comme avec des Français; les élèves ne songent pas à traduire de l'anglais pour me répondre; ils pensent en français; ils sont Français pour le moment par les yeux, par l'oreille, par la pensée. Quel autre livre pourrait produire cette illusion? . . ."

Votre tout dévoué,

A. DE ROUGE-MONT.

Illustrated Language Primers.

FRENCH AND ENGLISH.

GERMAN AND ENGLISH.

SPANISH AND ENGLISH.

The names of common objects properly illustrated and arranged in easy lessons.

Pujol's Complete French Class-Book.

Offers in one volume, methodically arranged, a complete French course — usually embraced in series of from five to twelve books, including the bulky and expensive lexicon. Here are grammar, conversation, and choice literature, selected from the best French authors. Each branch is thoroughly handled; and the student, having diligently completed the course as prescribed, may consider himself, without further application, *au fait* in the most polite and elegant language of modern times.

MODERN LANGUAGES—*Continued.*

Pujol's French Grammar, Exercises, Reader. 3 vols.

These volumes contain Part I., Parts II. and III., and Part IV. of the Complete Class-Book respectively, for the convenience of scholars and teachers. The Lexicon is bound with each part.

Maurice-Poitevin's Grammaire Française.

American schools are at last supplied with an American edition of this famous text-book. Many of our best institutions have for years been procuring it from abroad rather than forego the advantages it offers. The policy of putting students who have acquired some proficiency from the ordinary text-books, into a Grammar written in the vernacular, cannot be too highly commended. It affords an opportunity for finish and review at once, while embodying abundant practice of its own rules.

SPANISH.

Worman's First Spanish Book.

On same plan as Worman's first German and French Books. Teaches by direct appeal to illustrations, and by contrast, association, and natural inference. 96 pp.

These little books work marvels in the school-room. The exercises are so developed out of pictured objects and actions, and are so well graduated, that almost from the very outset they go alone. A beginner would have little use for a dictionary in reading. The words are so introduced, and so often used, that the meaning is kept constantly before the mind, without the intervention of a translation.

OTHER SPANISH BOOKS TO FOLLOW.

ANCIENT LANGUAGES.

LATIN.

Searing's Virgil's Æneid, Georgics, and Bucolics.

1. It contains the first six books of the Æneid and the entire Bucolics and Georgics. 2. A very carefully constructed Dictionary. 3. Sufficiently copious notes. 4. Grammatical references to four leading Grammarians. 5. Numerous illustrations of the highest order. 6. A superb map of the Mediterranean and adjacent countries. 7. Dr. S. H. Taylor's "Questions on the Æneid." 8. A Metrical Index, and an essay on the Poetical Style. 9. A photographic *fac-simile* of an early Latin MS. 10. The text is according to Jahn, but paragraphed according to Ladewig. 11. Superior mechanical execution.

"My attention was called to Searing's Virgil by the fact of its containing a vocabulary which would obviate the necessity of procuring a lexicon. But use in the class-room has impressed me most favorably with the accuracy and just proportion of its notes, and the general excellence of its grammatical suggestions. The general character of the book, in its

paper, its typography, and its engravings, is highly commendable, and the *fac-simile* manuscript is a valuable feature. I take great pleasure in commending the book to all who do not wish a complete edition of Virgil. It suits our short school courses admirably." HENRY L. BOLTWOOD, *Master Princeton High School, Ill.*

Johnson's Persius.

The Satires of Aulus Persius Flaccus, edited, with English notes, principally from Conington. By Henry Clark Johnson, A. M., LL.B., Professor of Latin in the Lehigh University.

SCHOOL MUSIC.

Ryan's Vocalist.

A new singing book for Graded Schools, Seminaries and social assemblies. 232 pages, long 8vo, cloth.

The National School Singer.

Bright, new music for the day school, embracing Song Lessons, Exercise Songs, Songs of Study, Order, Promptness, and Obedience, of Industry and Nature, Patriotic and Temperance Songs, Opening and Closing Songs; in fact, everything needed in the school-room. By an eminent musician and composer.

Jepson's Music Readers. 3 vols.

These are not books from which children simply learn songs, parrot-like, but teach the subject progressively, the scholar learning to read music by methods similar to those employed in teaching him to read printed language. Any teacher, however ignorant of music, provided he can, upon trial, simply sound the scale, may teach it without assistance, and will end by being a good singer himself. The "Elementary Music Reader," or first volume, fully develops the system. The two companion volumes carry the same method into the higher grades, but their use is not essential.

The First Reader is also published in three parts, at thirty cents each, for those who prefer them in that form.

Nash and Bristow's Cantara.

The first volume is a complete musical text-book for schools of every grade. No. 2 is a choice selection of solos and part songs. The authors are Directors of Music in the public schools of New York City, in which these books are the standard of instruction.

The Polytechnic.

Collection of Part Songs for High and Normal Schools and Clubs. This work contains a quantity of exceedingly valuable material, heretofore accessible only in sheet form or scattered in numerous and costly works. The collection of "College Songs" is a very attractive feature.

Curtis's Little Singer:—School Vocalist.—Kingsley's School-Room Choir.—Young Ladies' Harp.—Hager's Echo (A Cantata).

SCHOOL DEVOTIONAL EXERCISE.

Brooks's School Manual of Devotion.

This volume contains daily devotional exercises, consisting of a hymn, selections of Scripture for alternate reading by teacher and pupils, and a prayer. Its value for opening and closing school is apparent.

Brooks's School Harmonist.

Contains appropriate *tunes* for each hymn in the "Manual of Devotion" described above.

Bartley's Songs for the School.

A selection of appropriate hymns of an unsectarian character, carefully classified and set to popular and "singable" tunes, for opening and closing exercises. The Secular Department is full of bright and well-selected music.

TEACHERS' AIDS AND SCHOOL REQUISITES.

CHARTS AND MAPS.

Baade's Reading Case.

This remarkable piece of school-room furniture is a receptacle containing a number of primary cards. By an arrangement of slides on the front, one sentence at a time is shown to the class. Twenty-eight thousand transpositions may be made, affording a variety of progressive exercises which no other piece of apparatus offers. One of its best features is, that it is so exceedingly simple as not to get out of order, while it may be operated with one finger.

Clark's Grammatical Chart.

Exhibits the whole science of language in one comprehensive diagram.

Davies's Mathematical Chart.

Elementary mathematics clearly taught to a full class at a glance.

De Rupert's Philological and Historical Chart.

This very comprehensive chart shows the birth, development, and progress of the literatures of the world; their importance, their influence on each other, and the century in which such influence was experienced; with a list for each country of standard authors and their best works. Illustrating also the division of languages into classes, families, and groups. Giving date of settlement, discovery, or conquest of all countries, with their government, religion, area, population, and the percentage of enrolment for 1872, in the primary schools of Europe and America.

Eastman's Chirographic Chart. Family Record.

Giffins's Number Chart.

Teaches addition, subtraction, multiplication, and division. Size, 23 x 31 inches.

Marcy's Eureka Tablet.

A new system for the alphabet, by which it may be taught without fail in nine lessons.

McKenzie's Elocutionary Chart.

Monteith's Pictorial Chart of Geography.

A crayon picture illustrating all the divisions of the earth's surface commonly taught in geography.

WM. L. DICKINSON, *Superintendent of Schools, Jersey City, says.*

"It is an admirable amplification of the system of pictorial illustration adopted

in all good geographies. I think the chart would be a great help in any primary department."

Monteith's Reference Maps. School and Grand Series.

Names all laid down in small type so that to the pupil at a short distance they are outline maps, while they serve as *their own key* to the teacher.

Page's Normal Chart.

The whole science of elementary sounds tabulated.

Scofield's School Tablets.

On five cards, exhibiting ten surfaces. These tablets teach orthography, reading, object-lessons, color, form, &c.

Watson's Phonetic Tablets.

Four cards and eight surfaces; teaching pronunciation and elocution phonetically. For class exercises.

Whitcomb's Historical Chart.

A student's topical historical chart, from the creation to the present time, including results of the latest chronological research. Arranged with spaces for summary, that pupils may prepare and review their own chart in connection with any text-book.

Willard's Chronographers.

Historical. Four numbers: Ancient chronographer, English chronographer, American chronographer, temple of time (general). Dates and events represented to the eye.

CHARTS, &c. — *Continued.*

Popular Folding Reading Charts.

In two parts. Price \$5.00 each. These fifty-three charts are the outgrowth of practical reading lessons, all of which have been tried with classes of little children, first as black-board lessons, and afterward as printed manuscripts. By this method all the lessons were adapted to the capacity of the children. The words have been carefully selected and graded from the child's own spoken vocabulary.

PART I.

The new words of the first part are taught by the word and sentence method, the object-words being illustrated by engravings.

All the lessons sparkle with real childlike expressions. The language is the language of childhood, and thus to the pupil becomes doubly interesting while at the same time progressive.

The **Clock Face**, with Movable Hands, is an important and attractive feature. The authors know from experience that very happy results can be had by its use. Teaching children to tell the time has always been expected of the teacher, though seldom, if ever, has an opportunity been afforded him to do so.

All the letters of the alphabet are taught by a series of writing lessons in the order of their development, and are finally grouped together in a script alphabet.

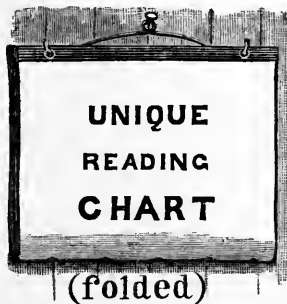

PART II

takes up the development of the **elementary sounds** of the language, from the words already learned in Part I., in such a way as to enable the child to see for himself how words are made, and giving the key by which he can make out for himself new words.

A series of **language lessons** is the feature of this part, by which children are gradually taught the use of words by composing brief sentences and original stories.

The **Color Chart** is the most unique feature ever offered to the public, enabling the teacher to teach the primary and secondary colors from nature.

Many review lessons are given in order that the children may learn to read by reading.

No easel or framework of any kind is required with the chart. The publishers have secured the exclusive right to use **Shepard's Patent Chart Binding**, the use of which gives it a decided advantage over any other reading chart yet made. It is in this respect unapproachable.

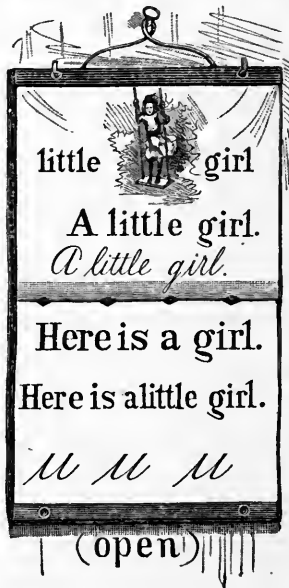

COPY-BOOKS, &c.

Barnes's New National System of Penmanship.

This new series of Copy-books, in six numbers, is based upon many years' experience. The publishers think these books are the best ever made in this country, for the following reasons:—

1. They contain a thoroughly Practical System of Penmanship, which, if once well learned in school, will not prove too difficult of execution for business purposes or private correspondence.

2. They have been prepared in the most careful manner, without regard to expense, by experts in the business; and the copies are infinitely superior to all others in the market, not only in beauty and grace of style, but also in accuracy of outline and proportion.

3. Pupils who use these books as directed will write in a free, graceful, rapid manner, and not in the slow, cramped, and crabbed style so common in many schools.

4. The classification of capitals is wonderfully simplified. Eleven letters are formed on one general plan; ten on another, and the rest on a third. The number of elements is reduced to five. Other systems have from seven to thirteen.

5. The gradation is perfectly simple. Only familiar words, and those easy of formation, are used, and not such unusual enigmatical words as "zengma," "urquesne," "xylus," "tenafly," "quinque," "minetic," "xuthus," and the like, that have long been the bane of both teachers and pupils.

6. No time has been lost by placing before the pupil disconnected words, unmeaning phrases, and stale aphorisms; but the complete sentence has been used early in the series, that the pupil, while writing, might be expressing thoughts, rather than simply copying abstract words.

7. The business forms are elaborately engraved on steel and printed on patent safety-tint paper. They are exactly like the checks, notes, drafts, receipts, etc., used in business, and the learning how to fill them out will serve as an admirable introduction to the counting-room.

8. The whole series for ungraded schools is comprised in six books; but for the benefit of the large, graded schools in both city and country, there are six additional books, of smaller size, to meet the demands of a still closer gradation.

Ward's Letter-Writing and Business Forms.

For Schools and Academies. In Four Numbers. No. 1, Letters and Bills. No. 2, Letters, Receipts, Accounts, etc. No. 3, Letters, Notes, Drafts, etc. No. 4, General Practice. 48 pages each. Price 15 cents each.

Intended to supply more practical work in the school-room. Letter-writing, Bills, Receipts, Accounts, Checks, Notes, and all Commercial forms are given for practice.

Beers's System of Progressive Penmanship.

This "round hand" system of Penmanship, in twelve numbers, commends itself by its simplicity and thoroughness. The first four numbers are primary books. Nos. 5 to 7, advanced books for boys. Nos. 8 to 10, advanced books for girls. Nos. 11 and 12, ornamental penmanship. These books are printed from steel plates (engraved by McLees), and are unexcelled in mechanical execution.

Beers's Slated Copy Slips.

Slate exercises, familiarizing beginners with the form of the letters, the motions of the hand and arm, etc., etc. These copy slips, 32 in number, supply all the copies found in a complete series of writing-books, at a trifling cost.

Fulton & Eastman's Chirographic Charts

To embellish the school-room walls, and furnish class exercise in the elements of Penmanship.

Payson's Copy-Book Cover.

Protects every page except the one in use, and furnishes "lines" with proper slope for the penman, under. Patented.

LIBRARY AND MISCELLANEOUS PUBLICATIONS.

TEACHERS' WORKING LIBRARY.

Object Lessons. Welch.

This is a complete exposition of the popular modern system of "object-teaching," for teachers of primary classes.

Theory and Practice of Teaching. Page.

This volume has, without doubt, been read by two hundred thousand teachers, and its popularity remains undiminished, large editions being exhausted yearly. It was the pioneer, as it is now the patriarch, of professional works for teachers.

The Graded School. Wells.

The proper way to organize graded schools is here illustrated. The author has availed himself of the best elements of the several systems prevalent in Boston, New York, Philadelphia, Cincinnati, St. Louis, and other cities.

The Normal. Holbrook.

Carries a working school on its visit to teachers, showing the most approved methods of teaching all the common branches, including the technicalities, explanations, demonstrations, and definitions introductory and peculiar to each branch.

School Management. Holbrook.

Treating of the teacher's qualifications; how to overcome difficulties in self and others; organization; discipline; methods of inciting diligence and order; strategy in management; object-teaching.

The Teachers' Institute. Fowle.

This is a volume of suggestions inspired by the author's experience at institutes, in the instruction of young teachers. A thousand points of interest to this class are most satisfactorily dealt with.

Schools and Schoolmasters. Dickens.

Appropriate selections from the writings of the great novelist.

The Metric System. Davies.

Considered with reference to its general introduction, and embracing the views of John Quincy Adams and Sir John Herschel.

The Student; The Educator. Phelps. 2 vols.

The Discipline of Life. Phelps.

The authoress of these works is one of the most distinguished writers on education, and they cannot fail to prove a valuable addition to the School and Teachers' Libraries, being in a high degree both interesting and instructive.

Law of Public Schools. Burke.

By Finley Burke, Counsellor-at-Law. A new volume in "Barnes's Teachers' Library Series." 12mo, cloth.

"Mr. Burke has given us the latest expositions of the law on this highly important subject. I shall cordially commend his treatise."—THEODORE DWIGHT, LL.D.

From the HON. JOSEPH M. BECK, Judge of Supreme Court, Iowa.

"I have examined with considerable care the manuscript of 'A Treatise on the

Law of Public Schools,' by Finley Burke, Esq., of Council Bluffs. In my opinion, the work will be of great value to school teachers and school officers, and to lawyers. The subjects treated of are thoughtfully considered and thoroughly examined, and correctly and systematically arranged. The style is perspicuous. The legal doctrines of the work, so far as I have been

MISCELLANEOUS PUBLICATIONS—Continued.

able to consider them, are sound. I have examined quite a number of the authorities cited; they sustain the rules announced in the text. Mr. Burke is an able and industrious member of the bar of the Supreme Court of this State, and has a high standing in the profession of the law."

"I fully concur in the opinion of Judge Beck, above expressed."—JOHN F. DILLON. *New York, May, 1880.*

SIoux CITY, IOWA, May, 1880.
I have examined the manuscript of Finley Burke, Esq., and find a full citation of all the cases and decisions pertaining to the school law, occurring in the courts of the United States. This volume contains

valuable and important information concerning school law, which has never before been accessible to either teacher or school officer.

A. ARMSTRONG,
Supt. Schools, Sioux City, Iowa.

DES MOINES, May 15, 1880.

The examination of "A Treatise on the Law of Public Schools," prepared by Finley Burke, Esq., of Council Bluffs, has given me much pleasure. So far as I know, there is no work of similar character now in existence. I think such a work will be exceedingly useful to lawyers, school officers, and teachers, and I hope that it may find its way into their hands.

G. W. VON COELLY,
Supt. Public Inst. for Iowa.

Teachers' Handbook. Phelps.

By William F. Phelps, Principal of Minnesota State Normal School. Embracing the objects, history, organization, and management of teachers' institutes, followed by methods of teaching, in detail, for all the fundamental branches. Every young teacher, every practical teacher, every experienced teacher even, needs this book.

From the New York Tribune.

"The discipline of the school should prepare the child for the discipline of life. The country schoolmaster, accordingly, holds a position of vital interest to the destiny of the republic, and should neglect no means for the wise and efficient discharge of his significant functions.

This is the key-note of the present excellent volume. In view of the supreme importance of the teacher's calling, Mr. Phelps has presented an elaborate system of instruction in the elements of learning, with a complete detail of methods and processes, illustrated with an abundance of practical examples and enforced by judicious councils."

Topical Course of Study. Stone.

This volume is a compilation from the courses of study of our most successful public schools, and the best thought of leading educators. The pupil is enabled to make full use of any and all text-books bearing on the given topics, and is incited to use all other information within his reach.

American Education. Mansfield.

A treatise on the principles and elements of education, as practised in this country, with ideas towards distinctive republican and Christian education.

American Institutions. De Tocqueville.

A valuable index to the genius of our Government.

Universal Education. Mayhew.

The subject is approached with the clear, keen perception of one who has observed its necessity, and realized its feasibility and expediency alike. The redeeming and elevating power of improved common schools constitutes the inspiration of the volume.

Oral Training Lessons. Barnard.

The object of this very useful work is to furnish material for instructors to impart orally to their classes, in branches not usually taught in common schools, embracing all departments of natural science and much general knowledge.

Lectures on Natural History. Chadbourne.

Affording many themes for oral instruction in this interesting science, especially in schools where it is not pursued as a class exercise.

MISCELLANEOUS PUBLICATIONS—*Continued.*

Outlines of Mathematical Science. Davies.

A manual suggesting the best methods of presenting mathematical instruction on the part of the teacher, with that comprehensive view of the whole which is necessary to the intelligent treatment of a part, in science.

Nature and Utility of Mathematics. Davies.

An elaborate and lucid exposition of the principles which lie at the foundation of pure mathematics, with a highly ingenious application of their results to the development of the essential idea of the different branches of the science.

Mathematical Dictionary. Davies and Peck.

This cyclopædia of mathematical science defines, with completeness, precision, and accuracy, every technical term; thus constituting a popular treatise on each branch, and a general view of the whole subject.

The Popular Educator. Barnes.

In seven volumes, containing interesting and profitable educational miscellany.

Liberal Education of Women. Orton.

Treats of "the demand and the method;" being a compilation of the best and most advanced thought on this subject, by the leading writers and educators in England and America. Edited by a professor in Vassar College.

Education Abroad. Northrop.

A thorough discussion of the advantages and disadvantages of sending American children to Europe to be educated; also, papers on legal prevention of illiteracy, study, and health, labor as an educator, and other kindred subjects.

The Teacher and the Parent. Northend.

A treatise upon common-school education, designed to lead teachers to view their calling in its true light, and to stimulate them to fidelity.

The Teachers' Assistant. Northend.

A natural continuation of the author's previous work, more directly calculated for daily use in the administration of school discipline and instruction.

School Government. Jewell.

Full of advanced ideas on the subject which its title indicates. The criticisms upon current theories of punishment and schemes of administration have excited general attention and comment.

Grammatical Diagrams. Jewell.

The diagram system of teaching grammar explained, defended, and improved. The curious in literature, the searcher for truth, those interested in new inventions, as well as the disciples of Professor Clark, who would see their favorite theory fairly treated, all want this book. There are many who would like to be made familiar with this system before risking its use in a class. The opportunity is here afforded.

The Complete Examiner. Stone.

Consists of a series of questions on every English branch of school and academic instruction, with reference to a given page or article of leading text-books where the answer may be found in full. Prepared to aid teachers in securing certificates, pupils in preparing for promotion, and teachers in selecting review questions.

How Not to Teach. Griffin.

This book meets a want universally felt among young teachers who have their experience in teaching to learn. It undertakes to point out the many natural mistakes into which teachers, unconsciously or otherwise, fall, and warns the reader against dangers that beset the path of every conscientious teacher. It tells the reader, also, the proper and acceptable way to teach, illustrating the author's ideas by some practice-lessons in arithmetic (after Grube).

MISCELLANEOUS PUBLICATIONS—*Continued.*

School Amusements. Root.

To assist teachers in making the school interesting, with hints upon the management of the school-room. Rules for military and gymnastic exercises are included. Illustrated by diagrams.

Institute Lectures. Bates.

These lectures, originally delivered before institutes, are based upon various topics in the departments of mental and moral culture. The volume is calculated to prepare the will, awaken the inquiry, and stimulate the thought of the zealous teacher.

Method of Teachers' Institutes. Bates.

Sets forth the best method of conducting institutes, with a detailed account of the object, organization, plan of instruction, and true theory of education on which such instruction should be based.

History and Progress of Education.

The systems of education prevailing in all nations and ages, the gradual advance to the present time, and the bearing of the past upon the present, in this regard, are worthy of the careful investigation of all concerned in education.

Higher Education. Atlas Series.

A collection of valuable essays. CONTENTS. International Communication by Language, by Philip Gilbert Hamerton; Reform in Higher Education; Upper Schools, by President James McCosh; Study of Greek and Latin Classics, by Prof. Charles Elliott; The University System in Italy, by Prof. Angelo de Gubernatis, of the University of Florence; Universal Education, by Ray Palmer; Industrial Art Education, by Eaton S. Drone.

LIBRARY OF LITERATURE.

Milton's Paradise Lost. (Boyd's Illustrated Edition.)

Young's Night Thoughts. do.

Cowper's Task, Table Talk, &c. do.

Thomson's Seasons. do.

Pollok's Course of Time. do.

These works, models of the best and purest literature, are beautifully illustrated, and notes explain all doubtful meanings.

Lord Bacon's Essays. (Boyd's Edition.)

Another grand English classic, affording the highest example of purity in language and style.

The Iliad of Homer. (Translated by Pope.)

Those who are unable to read this greatest of ancient writers in the original should not fail to avail themselves of this standard metrical version.

Pope's Essay on Man.

This is a model of pure classical English, which should be read, also, by every teacher and scholar for the sound thought it contains.

Improvement of the Mind. Isaac Watts.

No mental philosophy was ever written which is so comprehensive and practically useful to the unlearned as well as learned reader as this well-known book of Watts.

Milton's Political Works. Cleveland.

This is the very best edition of the great poet. It includes a life of the author, notes, dissertations on each poem, a faultless text, and is the only edition of Milton with a complete verbal index.

MISCELLANEOUS PUBLICATIONS—*Continued.*

Compendium of English Literature. Cleveland.

English Literature of XIXth Century. Cleveland.

Compendium of American Literature. Cleveland.

Nearly one hundred and fifty thousand volumes of Professor Cleveland's inimitable compendiums have been sold. Taken together they present a complete view of literature. To the man who can afford but a few books these will supply the place of an extensive library. From commendations of the very highest authorities the following extracts will give some idea of the enthusiasm with which the works are regarded by scholars:—

"With the Bible and your volumes one might leave libraries without very painful regret." "The work cannot be found from which in the same limits so much interesting and valuable information may be obtained." "Good taste, fine scholarship, familiar acquaintance with literature, unwearied industry, tact acquired by practice, an interest in the culture of the young, and regard for truth, purity, philanthropy, and religion are united in Mr. Cleveland." "A judgment clear and impartial, a taste at once delicate and severe." "The biographies are just and discriminating." "An admirable bird's-eye view." "Acquaints the reader with the characteristic method, tone, and quality of each writer." "Succinct, carefully written, and wonderfully comprehensive in detail," &c., &c.

THE TEACHER'S READING CIRCLE.

"No movement of modern times, rapid and startling as have been the changes in school methods, has ever made such simple and economical provisions for self-improvement among teachers, or promises such wide usefulness."—*The Educational Weekly.*

"A better indication of progress even than the improvement and increasing number of educational journals, is the formation of Teachers' Reading Circles. More may be confidently expected from these associations than from any other educational movement ever started in this country."—*The Practical Teacher.*

Among the leading publications selected for the Teachers' Reading Circles are the following:—

Barnes's Brief General History of the World.

From H. M. SKINNER, *Sec'y Indiana Reading Circle Board*: "It would not be asserting too much to say that if an author thoroughly competent had undertaken the preparation of a book expressly for the Reading Circle, — a book intended to impart general information and to encourage a taste for reading, — a work better adapted to the Reading Circle needs than Barnes's General History would hardly have been possible."

Page's Theory and Practice of Teaching. (New Ed.)

This volume has without doubt been read by several hundred thousand teachers, and its popularity remains undiminished — large editions being exhausted yearly. It was the pioneer, as it is now the patriarch, of professional works for teachers.

Watts's Improvement of the Mind. (New Edition.)

The ablest production of one of the most eminent writers of the English language. The amount of practical wisdom contained within its two hundred pages has challenged the admiration of the wisest of the two hemispheres for more than a century. This book should be carefully read and digested by every teacher and advanced student.

Hygiene for Young People.

Steele's Hygienic Physiology.

These books are of unsurpassed excellence. The text of each is brought fully up to the level of the New Physiological views, and the subjects are treated with special reference "to the effects of alcoholic drinks, stimulants, and narcotics upon the human system." They are essential to every well-regulated teacher's library.







UNIVERSITY OF CALIFORNIA LIBRARY

Los Angeles

This book is DUE on the last date stamped below.

SUBJECT TO FINE IF

NOT RETURNED TO

EDUCATION LIBRARY

RECEIVED

JUN 8 1964

AUG 21 1973

MAY 20 '81 -1 PM

APR 4 1966

RECEIVED

ED/PSYCH LIB.

APR 10 1971

AUG 27 1973

EDU./PSYCH.
LIBRARY

RECEIVED

APR 9 1971

JAN 3 1974

RECEIVED

EDU./PSYCH.
LIBRARY

JAN 08 1974

EDU./PSYCH.
LIBRARY

SEP 13 1971

RECEIVED

SEP 1 1971

QL JUN 29 1981

EDU./PSYCH.
LIBRARY

UCLA-ED/PSYCH Library

LB 1169 H12p



L 005 602 654 5

UC SOUTHERN REGIONAL LIBRARY FACILITY



A 000 993 617 0

