

UC-NRLF



\$B 26 066

THE
PRINCIPLES
OF
HEATING

WILEY & SONS

LIBRARY
OF THE
UNIVERSITY OF CALIFORNIA.

Class





PRINCIPLES OF HEATING

A practical and comprehensive treatise
on Applied Theory in Heating.

By WILLIAM G. SNOW,

Member

American Society of Mechanical Engineers.

American Society of Heating and Ventilating Engineers.



NEW YORK
DAVID WILLIAMS COMPANY
14-16 Park Place

TH 74-61
P 7

GENERAL

Copyright, 1907.
DAVID WILLIAMS COMPANY.

PRINCIPLES OF HEATING.

PREFACE.

While the title of this book may not be sufficiently comprehensive, it perhaps expresses, as nearly as may be done in a few words, the contents of the following pages. These are largely made up of a collection of articles by the author, which have appeared from time to time during the past few years in the *Metal Worker, Plumber and Steam Fitter*.

These contributions have been supplemented by reprints of articles relating to heating prepared by other writers.

Included in this work are the results of tests made by the author on heating apparatus and systems, together with numerous original tables and charts which he has found to be of practical use in the solution of heating problems.

Considerable space is devoted to a collection of articles on Vacuum and Vapor systems of heating, in view of the amount of interest manifested of late in this class of apparatus.

Special stress has been laid on the application of the heat unit to the solving of heating problems.

It is hoped that by the aid of the complete table of contents and the index persons interested in the subject treated will find the data contained in the following pages convenient for reference.

BOSTON, 1907.

WILLIAM G. SNOW.

TABLE OF CONTENTS.

CHAPTER I.

HEATING POWER OF FUELS, BOILERS AND COMBINATION HEATERS.

The Heat Unit.....	7
The Heating Power of Fuels, etc.....	8
Efficiency of Boilers and Coal Consumption.....	8
Computing Grate Surface on a Heat Unit Basis.....	10
Heating Surface in Boilers and Furnaces.....	10
Hot Water Combination Heaters.....	11
Dome Heater.....	12
Ring Heaters.....	12
Vertical Slab Sections.....	13
Pipe Coil Heaters.....	14
Types of Combination Heaters.....	16

CHAPTER II.

GAS, OIL AND ELECTRICITY VS. COAL.

General Discussion.....	17
Electric Heating.....	21

CHAPTER III.

THE CAPACITY AND FUEL CONSUMPTION OF HOUSE HEATING BOILERS.

How Compute Size of Boiler.....	23
Rate of Combustion.....	23
Amount of Fuel for a Season.....	25

CHAPTER IV.

FURNACE TESTS.

Tests on the Rate of Combustion in Furnaces and the Velocity of Air in the Pipes.....	27
A Cold Day Test.....	27
Data on Size of Rooms, Pipes, and the Flow of Air.....	28
Other Tests.....	29
Advantages of Air Supply at Relatively Low Temperatures	30

CHAPTER V.

SPECIFIC HEAT, THE HEATING AND COOLING OF AIR AND HUMIDITY.

Specific Heat and the Heating and Cooling of Air.....	31
Cooling Air.....	32
Mechanical Equivalent of Heat.....	33
Evaporation and Humidity.....	34

CHAPTER VI.

HEAT GIVEN OFF BY DIRECT RADIATORS AND COILS.

Notes on Heat Emitted by Direct Radiators.....	37
Heat Given Off by Indirect Radiators.....	40
Heat Given Off by Heaters Combined with Fans.....	44
Temperature of Air Required to Heat Rooms by Indirect Radiation	45
Size of Aspirating Heaters or Coils.....	48

CHAPTER VII.

THE LOSS OF HEAT BY TRANSMISSION, COMPUTING RADIATION.

Computation of Heat Losses and Radiation.....	54
Computing Direct Radiation on the Heat Unit Basis.....	56
The Boiler Horse-Power and Radiating Surface Required to Heat Isolated Buildings.....	63
Size of Heaters with Blower Systems.....	64
Relative Loss of Heat from Buildings Having the Same Cubic Contents.....	67

CHAPTER VIII.

HEATING WATER.

Heating Water by Submerged Steam Pipes.....	68
Hot Water Generators.....	69
Boiling Liquids in Vats.....	70
Heating Small Swimming Pools.....	71
Heating Large Swimming Pools.....	73
Amount of Steam and Size Boiler Required.....	73
Amount of Steam Pipe Required.....	74
Size Boiler Required.....	74
Tank Heaters.....	75
Water Backs and Gas Heaters.....	77

CHAPTER IX.

THE FLOW OF STEAM IN PIPES AND THE CAPACITIES OF PIPES FOR STEAM HEATING SYSTEMS AND FOR STEAM BOILERS.

A Comparison of Formulas.....	81
Application of Factors to Table XVI.....	82
Resistances to the Flow of Steam.....	83
Effect of Condensation.....	85
Steam Flow With More Than 40 Per Cent. Drop in Pres- sure	86
Relative Capacities of Pipes.....	86
Sizes of Steam Heating Mains.....	88
Sizes of Risers—One-Pipe System.....	90
Sizes of Risers—Two-Pipe System.....	91
Pipe Sizes for the Two-Pipe Vacuum System of Steam Heating	92
Comparison of Different Methods of Determining the Size of Steam Mains to Supply Radiating Surfaces.....	94
Low Pressure Heating Mains.....	99
Sizes of Main Steam Pipe Connections with Boilers.....	102
Sizes of Steam and Exhaust Pipes for Engines.....	103
Effect of Back Pressure on Simple Automatic Engines....	105
Effect of Back Pressure on Compound Engines.....	105
Counteracting Back Pressure by Increased Boiler Pressure	106
Steam Heating in Connection with Condensing Engines..	106

CHAPTER X.

CAPACITIES OF PIPES FOR HOT WATER HEATING.

The Flow of Water in Pipes.....	108
Volume of Water to Supply Radiators.....	109
The Velocity in Hot Water Heating Pipes.....	110
Radiating Surface Supplied by Pipes of Different Sizes..	110
Pipe Sizes for Indirect Heating.....	112
Sizes of Risers.....	113
Radiator Connections.....	114
Elbows and Bends.....	115
Expansion Tanks.....	115

CHAPTER XI.

VACUUM AND VAPOR SYSTEMS OF STEAM HEATING.

The Webster System.....	117
Heating at Night.....	118
Back Pressure Valves and Pressure Reducing Valves....	119
Advantages Claimed.....	119
Pipes, Sizes.....	122
The Paul System.....	123
Absence of Back Pressure.....	125
Steam to Operate the Ejector.....	125
Advantages Claimed.....	125
Heating with Radiators at a Relatively Low Temperature	126
Donnelly Positive Differential System of Exhaust Steam Circulation	127
The Thermograde System of Steam Heating.....	128
McGonagle Vacuum System for Low Pressure Plants....	131
Suggestions to Fitters.....	133
The K-M-C Vacuum System (Morgan Patents).....	134
The Trane Vacuum System.....	137
Advantages Claimed for the Mercury Seal Vacuum System	139
Comparison with Hot Water Heating.....	141
Vacuum Air Valves and the Norwall System.....	141
Gorton Vapor Vacuum System of Heating.....	143
Broomell's Vapor System of Heating.....	146
Advantages Claimed for the Vapor System.....	150



CHAPTER I.

HEATING POWER OF FUELS, BOILERS AND COMBINATION HEATERS.

THE HEAT UNIT.

What the pound is to the grocer, and the 2-foot rule is to the carpenter, the heat unit should be to those engaged in heating and ventilating work. It is their unit of measurement and is the common sense basis of all heating calculations. Briefly stated, a heat unit is the amount of heat required to raise the temperature of 1 pound of water 1 degree F.

To make practical use of the heat unit one must become familiar with the heating power of fuels, the loss of heat through walls

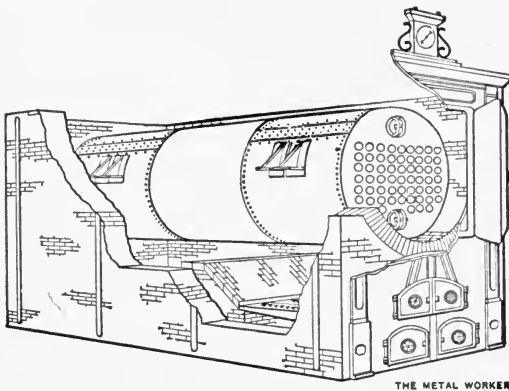

Fig. 1.—Horizontal Tubular Boiler.

and glass, the heat emitted by radiators and many other facts bearing on the subject. It is hoped this information will prove useful to those who wish to know the "whys and wherefores" of heating calculations and are not content to blindly follow "thumb rules," which may be good enough for small work, but for large undertakings are apt to give very unsatisfactory results and bring a serious loss to the contractor. A good grasp of the "heat unit basis" gives one confidence to attack and the ability to solve almost any heating problem that may arise.

THE HEATING POWER OF FUELS, ETC.

Anthracite coal has a theoretical heating power of about 14,200 heat units per pound of combustible. With 10 per cent. ash and noncombustible matter, 1 pound has a heating power of about 13,000 heat units. The smaller the coal the greater the percentage of ash, 16 per cent. or more being not uncommon with the smaller sizes.

Coke, like anthracite coal, consists almost entirely of carbon and has about the same heating power.

Good bituminous coal has a heating power of about 13,000 to 14,000 heat units per pound of combustible.

About $2\frac{1}{2}$ pounds of dry wood have the same heating power as a pound of coal.

Taking a fair average, 25,000 cubic feet of natural gas, or 40,000 cubic feet of illuminating gas, are equivalent in heating power to a ton of coal. A cubic foot of ordinary illuminating gas has a heating power ranging, as a rule, from 600 to 700 heat units.

The heating power of 1 pound of crude petroleum is about 21,000 heat units, the refined oil, or kerosene, having a heating power, in round numbers, of 27,000 to 28,000 heat units.

Electrical heat units are: 1 kilowatt hour equals 3412 heat units; 1 watt hour equals 3.412 heat units; 1 heat unit equals 0.293 watt hours.

A person gives off about 400 heat units per hour, an ordinary gas burner approximately 4,000 heat units and an incandescent electric light of 16 candle-power about 190 heat units.

EFFICIENCY OF BOILERS AND COAL CONSUMPTION.

To determine the probable coal consumption in a heating boiler one must assume a certain efficiency. It is of interest in this connection to discuss briefly the efficiency and coal consumption of high pressure boilers of the types shown in Figs. 1 and 2, and to show the application of the heat unit in solving problems of this nature. A boiler horse-power is equivalent to 33,305 heat units per hour; hence 3 pounds of combustible per horse-power is equivalent to 11,102 heat units out of a possible 14,000 in round numbers, representing an efficiency of about 80 per cent. With 4 pounds of combustible per horse-power these figures

would be reduced to 8,326 and 60 per cent. respectively, the latter conforming more nearly to ordinary working conditions than does 80 per cent. Suppose a boiler evaporates 9 pounds of water per pound of coal containing about 16 per cent. ash; then 1 pound of coal will contain only about $\frac{5}{6}$ pound of combustible, or the evaporation will be equivalent to about 11 pounds of water per pound of combustible. To evaporate 1 pound of water at a temperature of 212 degrees F. into steam at the same temperature requires about 964 heat units; hence the evaporation of 11 pounds

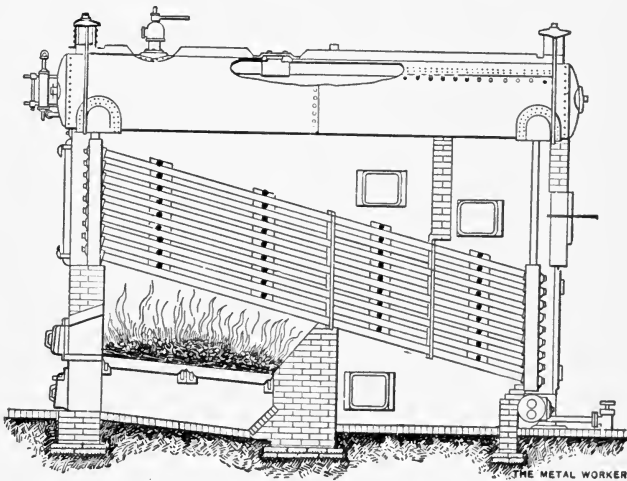

Fig. 2.—Water Tube Boiler.

of water by 1 pound of combustible is equal to 10,604 heat units per pound, or approximately 76 per cent. of the theoretical amount of heat in the coal.

Such an efficiency may be obtained under well managed high pressure boilers, but smaller cast iron heating boilers, illustrated in Figs. 3 and 4, will with the less skillful attendance given them have hardly more than 60 per cent. efficiency. In other words, we would not be likely to transfer from the fire to the water in the heater more than 8,000 to 9,000 heat units per pound of coal.

The distinction between coal and combustible must be kept in mind, the latter being only the burnable portion of the fuel.

COMPUTING GRATE SURFACE ON A HEAT UNIT BASIS.

A knowledge of the heat utilized per pound of coal burned and the total loss of heat from a building, the latter to be computed as described later, gives a convenient basis for determining the size of the heater, irrespective of the total radiating surface, on which the size is commonly based. If each pound of coal burned gives up to the water in the heater 8,000 heat units; dividing the total heat loss per hour from the building by 8,000 gives the weight of coal that must be burned. The grate surface is then

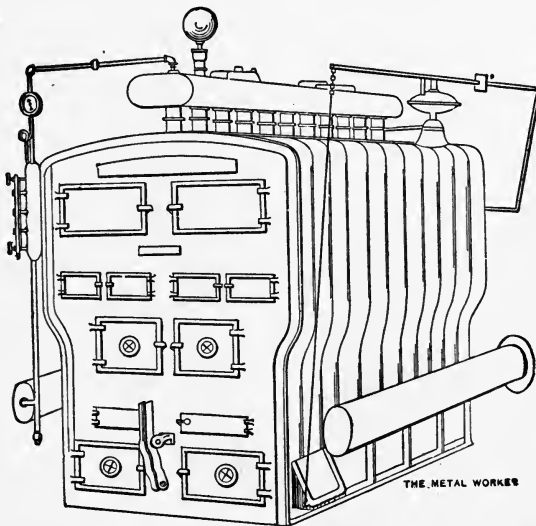

Fig. 3.—Sectional Cast Iron Boiler with Vertical Sections.

determined by dividing the weight just computed by 3 to 4 for small boilers, 4 to 5 for those of medium size, and by 5 to 7 for large sized boilers. These figures represent permissible rates of combustion, expressed in pounds of coal burned per square foot per hour in house heaters.

HEATING SURFACE IN BOILERS AND FURNACES.

The proper grate surface is only one element to be determined. It is equally important to see that the heater selected has the proper amount of heating surface well located. As to the amount of heat absorbed per square foot of heating surface, the small

boilers mentioned commonly have only 10 to 15 square feet of heating surface per square foot of grate, the medium sizes 16 to 20, and the larger ones 20 to 25. These proportions, with the rates of combustion stated, give from 2,000 to 2,200 heat units absorbed per hour per square foot of heating surface.

Hot air furnaces commonly have 15 to 20 square feet of heating surface to each square foot of grate. Taking the average, $17\frac{1}{2}$, and a 5-pound rate of combustion, the heat emitted per square foot of heating surface would be $\frac{5 \times 8,000}{17.5} = 2,400$. This figure is, of course, only approximate, the kind and location

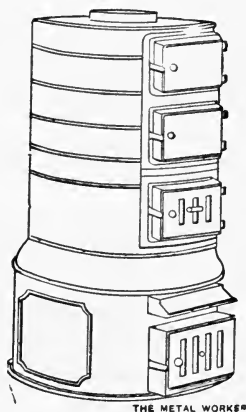

Fig. 4.—Sectional Cast Iron Boiler with Horizontal Sections.

of the heating surface making some portions more effective and others less so than the average. The heat given off varies also with the rate of combustion, but not at all in proportion to it.

HOT WATER COMBINATION HEATERS.

At best it is difficult, in a combination system of heating, to secure a proper balance between the hot water and hot air. Much depends on the proper rating of the coil or special casting used for heating the water. A number of tests made by the writer on various types of these heaters have established ratings which may safely be used in proportioning systems of this kind. In making the tests, radiators were arranged so that the total amount of surface connected with the heater could be nicely regulated to de-

termine the total radiating surface that could be maintained at an average temperature of about 160 degrees for hours at a time with an even fire and an ordinary rate of combustion.

DOMES HEATER.

A dome shaped cast iron section, of the general type illustrated in Fig. 5, proved capable of maintaining an average temperature in the flow pipe of about 160 degrees when supplying approximately 15 square feet of radiating surface to each square foot of heating surface. A great increase in capacity was noted when the fire was bright on top, the heater then being subjected to the direct rays from the burning coal. At other times it was merely

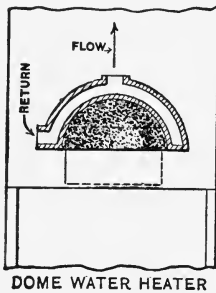

Fig. 5.—Type A.

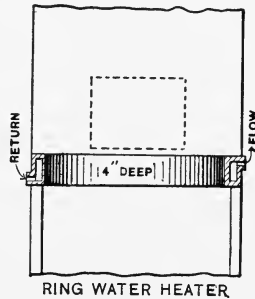

Fig. 6.—Type B.

surrounded by hot gases. The rating given is that under average conditions during an eight-hour run.

RING HEATERS.

A fire pot having a cored space $4\frac{1}{2}$ inches high by about 1 inch wide extending around the entire circumference, as shown in Fig. 6, was next tested. Three tests, each of about eight hours' duration, showed this type of combination heater, having a total of 5 square feet of heating surface, to be capable of heating to an average temperature of 170 degrees, the water in the flow pipe connected with 250 square feet of direct radiation. This is equivalent to a capacity of 50 square feet of direct radiation to every square foot of heating surface in contact with the fire. A combination of the ring and the dome shown in Fig. 7, has the heating capacity stated in Table I.

Another combination heater of a similar type, shown in Fig. 8.

was tested, the cored portion of the fire pot being 8 inches high, or about two-thirds the depth of the fire. Three eight-hour tests proved these heaters capable of heating the water in the flow pipe to about 160 degrees when connected with approximately 300 square feet of radiation. This heater had nearly twice the surface of the one previously described, yet the radiating surface carried was only about 20 per cent. more and was not so hot. Only about 30 square feet of radiating surface was supplied per square foot of heating surface exposed to the fire. The rapid falling off in efficiency was due to the chilling effect on the fire of so large a body of water, necessitating more frequent attention than with the

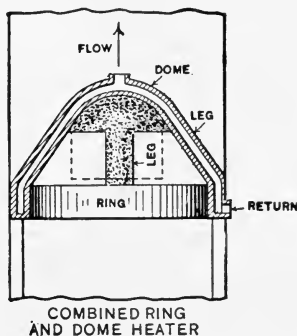

Fig. 7.—Type C.—A Combination of A and B.

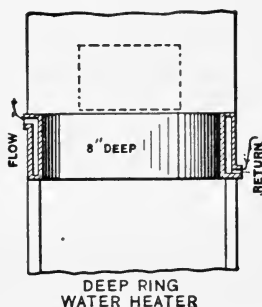

Fig. 8.—Deep Form of Type B.

other combination heaters tested. The average rate of combustion during the tests was about $3\frac{1}{2}$ pounds of hard coal per square foot of grate surface per hour.

In each of the three series of tests the drop in temperature between the flow and return pipes was, on an average, about 20 degrees and remained nearly uniform throughout.

VERTICAL SLAB SECTIONS.

Some makers who use vertical hollow cast iron slabs in connection with brick lined furnaces rate them as high as 75 square feet of radiating surface per square foot of heating surface. This rating is 50 per cent. greater than the highest one stated above. With a brisk fire there is no question that a square foot

of heating surface in direct contact with the fire will carry at least 75 square feet of heating surface, but it seems hardly wise to

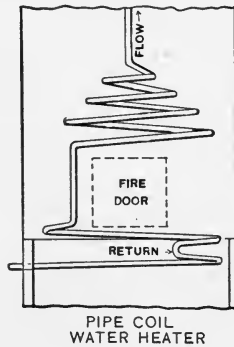

Fig. 9.—Type F.

reckon on its doing so right along, in view of the kind of attention commonly bestowed on furnace fires.

PIPE COIL HEATERS.

Coils of $1\frac{1}{4}$ or $1\frac{1}{2}$ -inch pipes, as shown in Fig. 9, make an excellent form of heater to combine with furnaces, especially if arranged so that the lower portion may be either above the fire or buried in it, according to the height at which the fire is carried,



Fig. 10.—Auxiliary Heater for Combination Heating.

thus giving a ready means of regulating the temperature of the water; since the coil, when in contact with the fire, is about twice

as effective as when the fire is kept several inches below it. Pipe coils, when suspended above the fire, may be rated to carry from 20 to 25 square feet of radiating surface per square foot of heat-

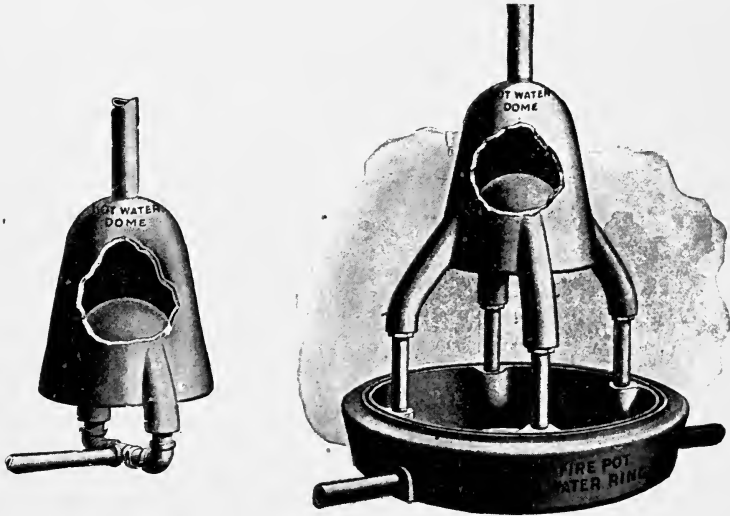

Fig. 11.—Types of Dome Heater for Combination Heating.

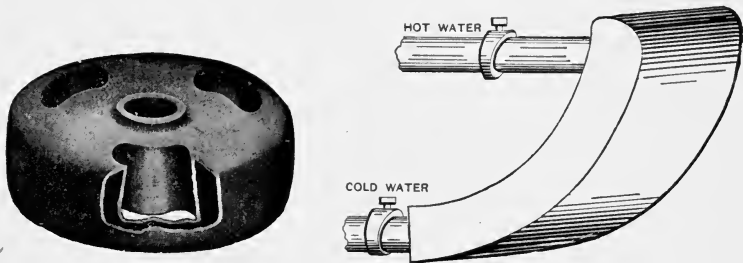

Fig. 12.—Disk Heater for Combination Heating.

Fig. 13.—Overhanging Type of Auxiliary Heater.

ing surface, and say, 30 to 40 square feet when arranged as described, the lower strand of the coil to be in contact with the fire. Single coils placed in the fire will carry at least 50 square feet of surface per square foot of coil.

Work installed on the basis of the figures above given has

proved satisfactory under the practical working conditions found in dwellings:

TABLE I.

SUMMARY, GIVING RATINGS FOR DIFFERENT CLASSES OF COMBINATION HEATERS.

Description.	Rating expressed in the number of square feet of direct radiating surface, which may be kept at a temperature of 160 degrees per square foot of heating surface in the combination heater.
A.—Cast iron sections suspended above the fire.....	15 to 20
B.—*Cast iron sections in contact with the fire.....	40 to 60
C.—A and B combined.....	25 to 35
D.—Pipe coil suspended above the fire.....	20 to 25
E.—Pipe coil buried in the fire.....	50 to 60
F.—D and E combined.....	30 to 40

* Capacity decreases as the depth of the surface in contact with the fire is increased, since the deeper the section the greater the chilling effect of the water on the fire and the harder to keep up the latter.

TYPES OF COMBINATION HEATERS.

A number of common types of combination heaters on the market are shown in Figs. 10, 11, 12, 13 and 14.

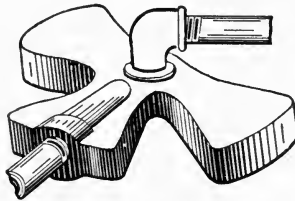

Fig. 14.—Maltese Type of Auxiliary Heater.

CHAPTER II.

GAS, OIL AND ELECTRICITY vs. COAL.

The question sometimes comes up whether to use gas or oil, instead of coal, for heating purposes. On a heat unit basis, we may not expect to utilize more than 8,000 to 9,000 units from each pound of coal burned. Comparing this with gas having a heating power of about 700 heat units per cubic foot, and assuming that 75 per cent. of the heat is transferred to the water in the heater, we have 525 heat units utilized per cubic foot of gas burned. From a ton of coal there would be utilized 2,000 (lbs.) \times 8,500 (heat units, as a maximum) = 17,000,000 heat units. This amount divided by 525 gives 32,400 cubic feet, or the equivalent amount of gas in heating effect. This volume of gas, at \$1 per 1,000, would cost more than five times as much as a ton of coal at \$6 per ton having the same heating power. Of course, the great advantages possessed by gas over coal are the absence of dirt and the ability to instantly turn on or shut off the heat.

The following statement by B. T. Galloway,* who made a number of experiments on oil and gas heating, is of interest:

“Oil (and by this material we mean the refined product, kerosene) may be dismissed with a few words, as, after many trials with numerous devices, it is found to be impracticable as a means of heating water or generating steam. In all of our experiments oil and gas were used to heat water circulating either in pipes or ordinary radiators. Taking an ordinary heating plant, say with a radiating capacity of 500 to 1,000 square feet, oil, when burned in the boiler with any of the so-called hydrocarbon burners, would be beyond the means of the ordinary house owner. The cost of heating 500 square feet of radiation, using kerosene oil and the best devices we have been able to secure or make, would be about three times as great for oil as compared with anthracite coal, provided coal was selling at \$6 per ton delivered in the cellar, and oil at 10 cents per gallon delivered in the same way. Then the

* See “Heating Experiments with Oils and Manufactured Gas,” by B. T. Galloway, in *The Metal Worker, Plumber and Steam Fitter*, October 17, 1903.

labor of handling oil, watching the burners and keeping the apparatus in order is fully as great as that connected with putting on coal and taking out ashes. Furthermore, we have never seen an oil device that could be entirely trusted, as experience with them shows that, when least expecting it, they go wrong, and fire and explosion follow unless great care is observed. The utilization of oil, therefore, as described, is hardly to be recommended.

“There is one method of utilizing oil, however, which is worthy of further trial and consideration—viz., that of adopting as a burner the ordinary blue flame oil stove, of which there are

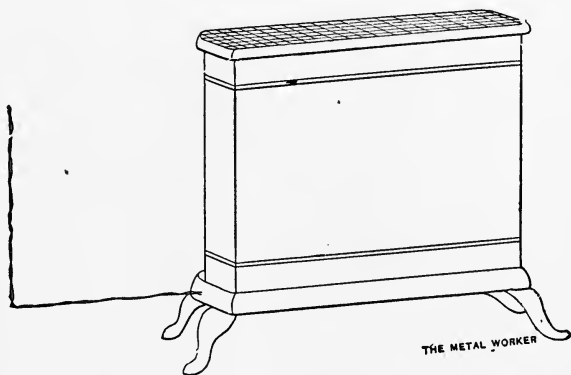

Fig. 15.—Type of Electric Radiator.

several kinds on the market. The burners for these stoves can be bought separately. They have a gravity feed, and will run indefinitely with little care and attention.

“It was found that boilers made for coal with their arrangements for cinders, drafts, etc., were poorly adapted for the use of a fuel as costly as gas. Only a small portion of the efficient heat units in the gas could be utilized, the rest going up the chimney or being lost in overcoming the resistance offered by the iron and in other ways. With specially constructed boilers, and by such we mean those where the flame of the burning gas can be brought into direct contact with a large surface of some metal like copper, much more effective results can be obtained than where ordinary boilers made for coal are used. Types of such boilers are to be found in those used for automobiles containing either a large number of small copper tubes or consisting of series upon series of

copper coils through which the circulating water passes. Even with such devices, however, it has been found impracticable to sufficiently heat the water from a central plant, except at a cost considerably more than that of coal at ordinary prices. In actual practice the cost of the gas would be about double that of coal, the price of the latter being estimated at \$6 per ton, and the former at \$1 per 1,000 cubic feet, 22 candle-power. Of course, in this case there is no coalman to bother with, no ashes to take out and no trouble in regulating the apparatus with the proper de-



Fig. 15A.—Luminous Electric Radiator.

vices at hand. Theoretically, and practically too for that matter, there is no reason why a householder could not light his burner in the autumn and the apparatus would do the rest, until it was time to turn the gas off in the spring. By means of properly adjusted regulators, the gas would be fed to the burner in sufficient amounts to maintain a uniform temperature in the room above. With gas at present prices this method of heating would be practically prohibitive for many, notwithstanding its advantages."

Extracts from an article by Donald McDonald on "Domestic Heating by Gas"* seem worth repeating here:

* See "Domestic Heating by Gas," Donald McDonald, in *The Metal Worker, Plumber and Steam Fitter*, October 24, 1903.

“Where the gas is the only source of heat and the room is occupied as a bed chamber it is much better, although somewhat more expensive, to use a closed heater provided with a good flue. Such a heater must, however, meet many very rigid conditions; otherwise the flue connection will be worse than useless. First of all, the flue must be so open and must run so high that a down draft through it will be an impossibility. A few seconds of down draft, carrying with it a load of carbonic acid and nitrogen, will put out the fire, and the flue becoming cold, the down draft will continue and the apartment become full of gas. No flue at all is



Fig. 15B.—Non-Luminous Electric Radiator.

much better than this. The stove must also be so constructed that no more air is drawn through it than is necessary to burn the gas, otherwise there will be a great waste of heat up the chimney.

“The amount of air required to burn the gas, if it is cooled to 300 degrees before it reaches the chimney, will only carry away with it about 5 per cent. of the heat. Closed stoves, however, as generally constructed, send up the chimney anywhere from 20 to 80 per cent. of the heat produced by the gas. Any device which sends a part of the products of combustion up the chimney and the rest of it into the room is simply folly. The part which reaches the chimney is no better and no worse than the part which is

put into the room, and unless care is taken to send all the products of combustion up the chimney it is much more sensible not to send any of them.

“I have seen and heard many learned discussions as to the question of whether a luminous flame or a blue flame produces the most heat. Nearly all salesmen and dealers of gas stoves will insist that the particular burner which they are advocating produces a great deal more heat than any other burner. Of course, any chemist or any engineer knows that if the combustion is complete and all the products of combustion escape into the room to be heated, the room receives all the heat due to the combustion of the fuel, and no amount of ingenuity can increase this 1 per cent. If the combustion is not complete the odor will be so vile that no one will tolerate it. In other words, in this class of stoves the efficiency is almost always 100 per cent., and need not be considered at all in selecting them.”

ELECTRIC HEATING.

To determine, on the heat unit basis, what it would cost to heat a room with electricity by means of an electric radiator, or heater, as shown in Fig. 15, let us suppose, for example, that it is desired to know the cost of heating a corner room, 14 x 14 x 10 feet, ten hours per day under average weather conditions. With, say, 20 per cent. glass surface, the equivalent glass surface, corresponding to the exposure, would be (20 per cent. of 280 square feet = 56 square feet) + [$\frac{1}{4} \times (280 - 56) = 56$ square feet] = a total of 112 square feet of glass; wall surface being rated as one-fourth as much glass surface. One hundred and twelve square feet of glass \times 85 heat units per square foot an hour for 70 degrees difference in temperature \times 1.25 (the factor for northwest exposure) = approximately 11,900 heat units per hour.*

A certain allowance must be added for quickly warming the contents of the room, apart from the transmission loss above computed. To do this it is convenient to add to the computed loss of heat through walls and windows a number of heat units equal to at least one-third the cubic contents; in this case $1-3 \times 1,960 = 653$ heat units. This combined with the 11,900 heat units previously computed, gives a total of 12,553 heat units per hour.

* See page 53 and following for a fuller discussion of computation of heat losses.

Electric current, when metered, is charged for on the basis of watt hours, a heat unit being equivalent to 0.293 watt hour. Therefore, 12,553 heat units would be equivalent to 3,680 watt hours; or, to heat the room ten hours in zero weather by electricity would require 36,800 watt hours.

The average amount, during the heating season, would probably not exceed, for a ten-hour day, $\frac{30}{70} \times 36,800 = 15,800$ watt hours, approximately. Ten cents per 1,000 watt hours is a not uncommon rate for such service; and at this price the cost to heat the room ten hours per day in average weather would be \$1.58, a prohibitive cost.

With coal, such a room, with a 50 square foot steam radiator, would, in zero weather, allowing 250 heat units per square foot of radiating surface per hour and 8,000 heat units per pound of coal, take only 50 (square feet) $\times 250$ (heat units) $\times 10$ (hours) $\div 8,000 = 15.6$ pounds of coal, costing, say, 5 cents.

Electric heating is bound to be expensive in comparison with steam, if the exhaust from the power plant goes to waste, since about 90 per cent. of the heat of the steam passes away with the exhaust from the engines. With, say, 75 per cent. boiler efficiency, 10 per cent. engine efficiency on a heat unit basis and 85 per cent. on a mechanical basis (that is, allowing 15 per cent. for friction) and 90 per cent. dynamo efficiency and 95 per cent. line efficiency, we have for the combined efficiency of boiler, engine, dynamo and wires: $0.75 \times 0.10 \times 0.85 \times 0.90 \times 0.95 = 5.45$ per cent. The efficiency of a direct steam heating system would probably be as high as 55 to 60 per cent., or, say, 10 times that of the electric heating system.

CHAPTER III.

THE CAPACITY AND FUEL CONSUMPTION OF HOUSE HEATING BOILERS.

Manufacturers' boiler ratings vary so widely that it is worth while for contractors to compute the capacities themselves and not trust implicitly the figures given in the catalogues. The basis of computation should be the grate surface and the rate of combustion. In house heating boilers of medium size not more than 5 pounds of coal should be burned per square foot of grate surface per hour. As to a 5-pound rate being a fair maximum to assume, it may be compared with horizontal tubular boiler practice in which, with easy firing, a 10 to 12 pound rate is common. Such boilers have 33 to 40 square feet of heating surface per square foot of grate, whereas common sizes of house heating boilers have, roughly speaking, 16 to 20. Hence, with half the heating surface the rate of combustion should be proportionally lower in order that the heat may be as well absorbed. This would give a 5 or 6 pound rate for house heaters.

HOW COMPUTE SIZE OF BOILER.

To ascertain the size of boiler necessary to supply a given amount of direct radiation, say, 1,500 square feet, for example, including the surface in mains, first multiply the total surface by the heat given off per square foot per hour. With hot water, in the case taken for illustration, this would be $1,500 \times 150 = 225,000$ heat units. Assuming 8,000 heat units to be utilized per pound of coal burned, each square foot of grate, with a 5 pound rate of combustion, will give to the water in the boiler 40,000 heat units per hour. Therefore the grate surface required will be $225,000 \div 40,000 = 5.62$ square feet.

RATE OF COMBUSTION.

The rate of combustion should not exceed 5 pounds for boilers having, say, not over 6 or 8 square feet of grate surface.

Boilers with two or three times as large a grate are generally cared for by a paid attendant, in which case there is no objection to burning coal at a faster rate. Such boilers generally have more heating surface in proportion to the grate than the smaller ones, hence the increased output of heat will be readily absorbed and the boiler will be just as economical as a smaller one burning coal more slowly.

Small boilers with 10 to 15 square feet of heating surface per square foot of grate should be rated to do their work on a 3 to 4 pound rate of combustion, corresponding to about 160 to 210 square feet of hot water radiating surface per square foot of grate.

Medium size boilers, with 16 to 20 square feet of heating surface to 1 of grate, should be based on burning 4 to 5 pounds of coal on each square foot of grate per hour, corresponding, in round numbers, to 210 to 260 square feet of hot water radiation per square foot of grate.

Large size boilers with 21 to 25 or more square feet of heating surface per square foot of grate may be rated on a coal consumption of 6 to 7 pounds per square foot per hour, or even a trifle higher rate, where the heating surface is ample, corresponding approximately to 320 to 370 square feet of hot water radiation per square foot of grate. With steam radiation giving off, say, 250 heat units per square foot per hour, the same grate would carry only $150-250 = 3.5$ as much surface as with hot water radiation.

The maximum night rate, when a boiler is expected to run at least eight hours without attention, should not exceed 4 pounds, equal to 32 pounds of coal burned on each square foot of grate in that length of time. With the 4-pound rate of combustion assumed, a fire one foot thick would burn about half through during the night, leaving an ample quantity of unconsumed fuel on the grate to readily ignite the fresh fuel added in the morning. With a higher rate of combustion a thicker fire would be necessary. Too great a depth, however, would interfere with the draft.

One of the essentials in a house heating boiler is a fire box of sufficient depth to permit carrying a good deep fire. Thin fires require too frequent attention. Avoid boilers with grates of ex-

cessive length, owing to the difficulty of properly handling the fire.

AMOUNT OF FUEL FOR A SEASON.

To compute the season's coal consumption in a house is, as heating men know, a very uncertain problem. The radiating surface or the grate area may be taken as a basis. If the boiler is properly proportioned for its work, so that the maximum rate of combustion need not exceed that stated above, the amount of coal required may be computed most readily by basing it directly on the grate surface. With a climate like that in many sections of the northeastern part of this country, where the heating season is of about seven months duration and the average outside temperature during that time is not far from 40 to 45 degrees, the average rate of combustion will be, roughly, from $1\frac{1}{4}$ to $1\frac{3}{4}$ pounds per square foot per hour.

Take, for example, a boiler of medium size, in which the coal is to be burned no faster than a 5 pound rate in zero weather. Assume the heating season to last 200 days, or 4,800 hours. With an average outside temperature of, say, 45 degrees, the average rate of combustion, based on the difference between the indoor and outdoor temperatures, will be only $\frac{25}{70} \times 5 = 1.79$ pounds.

Making allowance for the lower temperature maintained at night brings the average rate down to about 1.68 pounds. This, with a boiler having 4 square feet of grate surface, gives $4 \times 1.68 \times 4,800 = 32,256$ pounds, or about 16 tons for the season.

If the estimate be based on the radiating surface instead of on the grate area, we may assume, for example, a house heated by 1,000 square feet of direct radiation, including mains as a part of the surface.

Using the figures previously stated—viz., 150 heat units per square foot of direct hot water radiating surface and 8,000 heat units utilized per pound of coal, we have $1,000 \times 150 \div 8,000 = 18.8$ pounds per hour in coldest weather. The average hourly consumption, with an outside temperature of 45 degrees, would be $\frac{25}{70} \times 18.8$, and the total for the season of 4,800 hours $\frac{25}{70} \times 18.8 \times 4,800 =$ approximately 32,200 pounds. This would be reduced,

owing to the lower temperature kept up at night to, say, 15 tons.

With indirect radiation, reduce to approximate equivalent direct radiation by multiplying by not less than 1.6. Some boiler manufacturers recommend multiplying by 1.75. Expressed in another way the computation just made, based on hot water radiation, gives about 40 pounds of coal per season per square foot of surface in radiators, allowing 25 per cent. for mains. With steam radiation the coal required would be $\frac{250}{150} \times 40 =$ about 70 pounds.

It may be well to repeat that the above computations apply only to properly proportioned systems. If a boiler is known to be small for its work a higher average rate of combustion must be assumed and vice versa.

There is no economy in having a boiler so large that the fire must be checked by opening the feed door or running with a very low rate of combustion.

With a pair of boilers it is better to run one at its maximum rate until the second one is needed rather than run both with drafts checked nearly to the limit.

CHAPTER IV.

FURNACE TESTS.

TESTS ON THE RATE OF COMBUSTION IN FURNACES AND THE VELOCITY OF AIR IN THE PIPES.

The following tests were made on the heating apparatus in a frame house 29 by 35 feet, with parlor, dining room and reception room on the first floor, and four bedrooms and a bathroom on the second floor, heated during one winter season by a brick lined wrought iron furnace with a 22-inch fire pot, and during the following season by a cast iron furnace with a tapering fire pot having an average diameter of about 23 inches.

The brick lined furnace was tested during a 20 days' run in midwinter. The average outside temperature during this period, based on readings taken night and morning, was 26.3 degrees; total weight of coal burned, 2,328 pounds; rate of combustion per square foot of grate per hour, 1.84 pounds. A cold day run was made a little later in the season, the thermometer ranging from 7 degrees below zero to 8 degrees above. During the 24 hours test coal was fed six times, the total weight amounting to 258 pounds, making the average rate of combustion 4.07 pounds per square foot of grate per hour.

The cast iron furnace was tested during a 32 days' trial, the average outside temperature based on three readings per day, being 27½ degrees. The total weight of coal burned was 4,350 pounds; the average per square foot of grate per hour being 1.97 pounds. During this test a record of room temperatures was kept, the average being fully 70 degrees.

A COLD DAY TEST.

During this test a particularly severe day occurred, the temperature falling to 12 below zero. The coal burned during these 24 hours amounted to 300 pounds, giving an average rate of 4.35 pounds per square foot of grate per hour. Coal was fed seven times. The fire pot was red hot while the thermometer remained

below zero. The weight of ashes and unconsumed fuel passing through the grate was 10 per cent. of the weight of Lehigh egg coal supplied. The house in which these furnaces were installed was of ordinary frame construction, shingled on building paper and plastered inside. The total cubic contents of rooms connected with the furnace was 11,674 cubic feet. The total combined exposed wall and glass surface was 1,683 square feet.

It is to be noted that both furnaces used were inside the average rating given by reputable manufacturers to furnaces of their size—namely, about 14,000 cubic feet. If based on the exposure such furnaces are expected to carry approximately 1,700 square feet of combined wall and glass surface when the latter does not exceed, say, one-sixth the total exposure. The exposure in this case is practically the same as the above figure. The house had storm windows on the north and west sides, yet an average rate of combustion of nearly 5 pounds per square foot of grate per hour was found necessary to keep the rooms comfortable in severe weather. This high rate requires pretty frequent attention and should be considered a maximum.

DATA ON SIZE OF ROOMS, PIPES, AND THE FLOW OF AIR.

The dimensions and other data of the several rooms are as follows:

TABLE II.
ANEMOMETER TESTS.—FURNACE HEATING.

Rooms.	Dimensions.—Feet.	Approximate contents. Cubic feet.	Sides exposed.	Size of register.	Diam. of pipe.
First floor.					
Dining room.....	13 x 18 x 8½	2,000	2	10 x 14	10
Parlor	14½ x 15 x 8½	1,850	2	10 x 14	10
Hall	14 x 18 x 8½	2,140	2	10 x 14	10
Second floor.					
Bedroom	9 x 12 x 8	864	2	8 x 12	7
Bedroom	10 x 19 x 8	1,520	2	8 x 12	8
Bedroom	10 x 12 x 8	960	1	8 x 12	7
Bedroom	13 x 13 x 8	1,350	2	9 x 12	8
Bath	6 x 7½ x 8	390	1	7 x 10	6
		11,674			

Anemometer tests were made with the following results:

Room.	Temperature at register.	Velocity in pipe. Feet.	Size pipe. Inches.	Horizontal run. Feet.	Elbows.	
	Deg. F.				90°	45°
First floor.						
Dining room.....	116	418	10	8	1	1
Parlor	114	429	10	2	..	2
Hall	146	465	10	4	1	1

Room.	Temper- ature at register.	Velocity in pipe.	Hori- zontal run.		—Elbows.—	
	Deg. F.	Feet.	Inches.	Feet..	90°	45°
Second floor.						
Bedroom	100	252	7	16	2	2
Bedroom	104	320	8	12	2	2
Bedroom	104	510	7	2	1	1
Bedroom	127	570	8	2	1	1
Bath	103	286	6	8	1	1

The above tests were made with cold air box wide open and with little or no wind. The outside temperature was 5 degrees. The register temperatures were lower than would have been necessary to keep the rooms comfortable had it not been that they had been warmed to a temperature considerably in excess of 70 degrees, and furnace drafts were checked to reduce the heat.

Other tests were made, closing all registers on the first floor, giving velocities of over 500 feet in the rooms on the second floor most remote from the furnace. Tests were made in 34 degree weather, showing a velocity of only about 280 feet in rooms on the first floor. Anemometer readings taken in the cold air box showed a velocity of over 300 feet and a volume of 900 to 980 cubic feet per minute, corresponding to an air change in the rooms heated once in about 13 minutes.

OTHER TESTS.

Tests made in another house with outside temperature 24 degrees showed velocities in pipes leading to the first floor ranging from 306 to 334 feet, the temperature at the registers ranging from 104 to 109 degrees. Pipes leading to the second floor showed velocities in excess of 450 feet per minute with slightly lower register temperatures than on the first floor. The furnace in this case had a 22 inch fire pot. The total volume of air supplied to the house per minute was 850 cubic feet.

Still another test, made in a different house, gave these results for rooms located on the second and third floors, the test being made in cold winter weather. It will be noted that the register temperatures in this case are much higher than in the previous tests:

TABLE III.

FLUE VELOCITIES.—FURNACE HEATING.

Room.	Temperature of entering air. Deg. F.	Velocity in pipe. Feet.	Size pipe. Inches.	Hori- zontal run.	
				Feet.	Elbows.
Parlor	138	250	6 x 10 oval.	9	3
Library	120	210	6 x 7½ oval.	4	2
Dining room.....	140	275	7 diameter.	15	2
Hall	151	450	6 x 8 oval.	7	2
Bath	108	280	6 diameter.	8	2
Bedroom	152	500	4½ x 7½ oval.	4	3
Rear bedroom.....	140	540	5 x 7 oval.	12	3

These tests give only a general idea of what velocities may be expected under ordinary working conditions. From the above and other data the writer has adopted these velocities in making furnace heating computations.

Approximate velocity in pipes leading to first floor, 280 feet per minute; to second floor, 400 feet per minute; to third floor, 500 feet per minute.

During the test made in weather 12 degrees below zero the temperature of the air delivered by the furnace was 113 to 115 degrees. When the outside temperature rose to 6 or 8 below zero 122 degrees were indicated by the thermometer placed at register nearest the furnace. The maximum increase in temperature noted was 130 degrees. The wind was blowing strongly into a wide open cold air box. Had this been partially closed the maximum temperature would doubtless have exceeded 140 degrees, which is commonly used as a basis for computations in work of this kind.

ADVANTAGES OF AIR SUPPLY AT RELATIVELY LOW TEMPERATURES.

There are advantages in supplying air at, say, 120 degrees in zero weather. There is less tendency for the air to remain at the ceiling than when admitted at a higher temperature, thus promoting a better circulation in the room and a nearer approach to a uniform temperature throughout. On the other hand, the lower the temperature of the air supply the greater must be the volume to supply the number of heat units necessary to make good the loss through exposed walls and glass, consequently the more frequent the air change and the greater the fuel consumption.

CHAPTER V.

SPECIFIC HEAT, THE HEATING AND COOLING OF AIR AND HUMIDITY.

SPECIFIC HEAT AND THE HEATING AND COOLING OF AIR.

Different substances vary greatly in the amount of heat they must absorb to raise their temperature a given amount. The quantity of heat that must be imparted to a body to raise its temperature 1 degree in comparison with that required to raise an equal weight of water 1 degree is known as the "specific heat" of the body. Thus, the specific heat of air is 0.2375 (generally taken as 0.238)—that is, only about one-fourth as many heat units are required to raise 1 pound of air 1 degree as would be necessary to raise 1 pound water the same amount. The specific heat of water varies slightly, but this need not be taken into consideration except for scientific work.

To determine how many heat units are required to heat a given volume of air a stated number of degrees the quickest method is probably to multiply the volume in cubic feet by the degrees rise in temperature and divide the product by 55, this number representing approximately the number of cubic feet of air at 70 degrees that will be raised 1 degree by one heat unit. One cubic foot of dry air at 70 degrees temperature weighs 0.0747 pound, or 1 pound occupies 13.4 cubic feet. One heat unit will raise $\frac{1}{0.238}$ pound of air 1 degree, equal to 4.2 pounds of air 1 degree. Since 1 pound of dry air occupies 13.4 cubic feet, 1 heat unit will raise 4.2×13.4 cubic feet 1 degree = 56 cubic feet; 55 cubic feet is commonly used in making approximate calculations. On precisely the same basis it will be found that 1 heat unit will raise approximately 50 cubic feet of air at zero through 1 degree, zero air weighing 0.0864 pound to the cubic foot.

TABLE IV.
THE WEIGHT OF AIR PER CUBIC FOOT AT DIFFERENT TEMPERATURES.

Temperature.—F.	Weight in pounds of 1 cubic foot of dry air.	Temperature.—F.	Weight in pounds of 1 cubic foot of dry air.
0.....	0.0864	92.....	0.0720
12.....	0.0842	102.....	0.0707
22.....	0.0824	112.....	0.0694
32.....	0.0807	122.....	0.0682
42.....	0.0791	132.....	0.0671
52.....	0.0776	142.....	0.0660
62.....	0.0761	152.....	0.0649
72.....	0.0747	162.....	0.0638
82.....	0.0733		

COOLING AIR.

When the volume of air to be cooled is small, ice is generally used, each pound in melting absorbing about 142 heat units. Suppose, for example, it is desired to know the weight of ice that must be melted to cool 60,000 cubic feet of air per hour from 90 down to 80 degrees, the water from the melted ice to be discharged at 62 degrees temperature :

	Heat units.
1 pound of ice, in melting, absorbs.....	142
1 pound of water, when warmed from 32° to 62°, absorbs.....	30
Total heat units absorbed.....	172

One cubic foot of air at 90 degrees weighs 0.072 pound. Hence 60,000 cubic feet will weigh 4,320 pounds. Since the specific heat of air is 0.238, the number of heat units that must be absorbed by melting ice to cool this weight of air 10 degrees will be 4,320 pounds \times 10 \times 0.238 = 10,250 heat units, approximately. Since 1 pound of ice melted and the water raised to 62 degrees absorbs 172 heat units, 10,250 \div 172 heat units will be required, equal to about 60 pounds of ice per hour to cool 60,000 cubic feet of air 10 degrees F.

The ice would be most effective if it were crushed into small pieces so that the air would come in close contact with it. This, unfortunately, would seriously retard the flow of air, owing to the increased resistance over that when large cakes are used. With the latter arranged in properly constructed racks and provision made for retaining the water until its temperature has increased to within 20 or 30 degrees of that of the air, good results have

been obtained; but practically one must expect the amount of ice required to exceed considerably the theoretical weight based on the volume of air cooled, since there are losses by transmission through surrounding partitions, walls, etc.

For large systems mechanical refrigeration should be used. It may be said in a general way that in small plants the consumption of 1 ton of coal is sufficient to produce 7 to 8 tons of commercial ice. The actual ice making capacity of a machine is only 50 to 60 per cent. of its ice melting capacity, which is expressed in tons capacity in 24 hours—that is, a 30-ton machine means a refrigerating capacity in 24 hours equivalent to that produced by the melting of 30 tons of ice. The machine would produce, however, only 15 to 18 tons of real ice in the same period. For cooling air with a refrigerating plant, brine at, say, 8 to 12 degrees F. would be circulated by pumps through coils over which the air would be required to pass.

Unfortunately, the cooling of air does not make it agreeable. Its relative humidity is increased, which makes it less capable of absorbing moisture or perspiration from the body. Therefore the air should be dried by passing it over trays of calcium chloride, which has a great capacity for absorbing moisture, or it may be slightly heated after the chilling process to reduce its humidity.

MECHANICAL EQUIVALENT OF HEAT.

A definite relation exists between work and heat. The unit of work is the foot-pound—viz., the work required to raise 1 pound 1 foot. It has been determined experimentally that 1 heat unit is equivalent to 778 foot-pounds.

Whenever mechanical work is done heat is given off. Thus, the heat due to the running of machines in a shop assists in the warming of the room. A horse-power is 33,000 foot-pounds per minute. For each mechanical horse-power expended in whatever manner in factory, shop or elsewhere, $33,000 \div 778 = 42.4$ heat units are given off. A mechanical horse-power hour is equal, then, to 2,544 heat units per hour, an amount equal to the loss of heat through over 30 square feet of glass, or that given off by 8 to 10 square feet of direct radiation.

EVAPORATION AND HUMIDITY.

To moisten air water must be evaporated or steam must be injected into it. In either case about 1,000 heat units are necessary for the evaporation of 1 pound of water or the making of 1 pound of steam. Water evaporates very slowly when exposed in still air, the evaporation per square foot from a water surface in contact with still air at 70 degrees having a relative humidity of 40, being about 1-40 pound per hour. The rate of evaporation rapidly increases with an increase in temperature or the passage of air across the surface of the water. The capacity of air to absorb moisture increases rapidly with its rise in temperature—*e. g.*, air at 70 degrees can absorb about four times as much moisture as air at 30 degrees, as will be seen by referring to Table V:

TABLE V.

THE WEIGHT OF WATER VAPOR PER CUBIC FOOT OF SATURATED SPACE AT DIFFERENT TEMPERATURES.

Tem- perature.	Weight of vapor in grains per cubic foot.	Tem- perature.	Weight of vapor in grains per cubic foot.
0.....	0.54	50.....	4.09 = 4 approx.
10.....	0.84	60.....	5.76
15.....	0.99 = 1 approx.	70.....	7.99 = 8 approx.
20.....	1.30	80.....	10.95
30.....	1.97 = 2 approx.	90.....	14.81
40.....	2.88	100.....	19.79 = 20 approx.

1 pound avoirdupois = 7000 grains.

Approximately 1000 heat units are required to evaporate 1 pound of water.

The amount of heat and fuel necessary to moisten air is not generally appreciated. To illustrate this point take the amount of heat required to moisten air entering a furnace at 30 degrees, with a relative humidity of 65, so that a relative humidity of 50 will be maintained in the rooms kept at 70 degrees. Assume that 50,000 cubic feet of air per hour passes through the furnace: One cubic foot of saturated air at 30 degrees temperature contains, approximately, 2 grains of moisture, and with a relative humidity of 65 would contain 1.3 grains. Each cubic foot of air at 30 degrees expands to 1.08 cubic feet when heated to 70 degrees. One cubic foot of saturated air at 70 degrees contains about 8 grains of moisture. With 50 relative humidity 1 cubic foot of 70-degree air would contain 4 grains.

The amount of moisture that must be supplied by the evaporating pan in the furnace is the difference between 50,000 cubic feet

per hour $\times 1.08 \times 4$ and $50,000 \times 1.3$. The difference equals 151,000 grains, or 21.6 pounds, per hour. Since about 1,000 heat units are required to evaporate 1 pound of water, 21,600 heat units per hour are absorbed, equal to the heat utilized from the burning of about $2\frac{1}{2}$ pounds of coal.

The effect of an ordinary evaporating pan is of slight consequence in moistening the large volume of air that passes through a furnace. If an attempt is made by specially provided means to raise the relative humidity in the room to, say, 50, in cold winter weather, the moisture will condense on the windows and they will become frosted. A relative humidity of about 30 is said to be as high as one can secure without this trouble from condensation.

CHAPTER VI.

HEAT GIVEN OFF BY DIRECT RADIATORS AND COILS.

Repeated tests have shown the amount of heat given off by ordinary cast iron radiators per square foot of heating surface per hour per degree difference in temperature between the steam or water in the radiator and the air surrounding same to be about

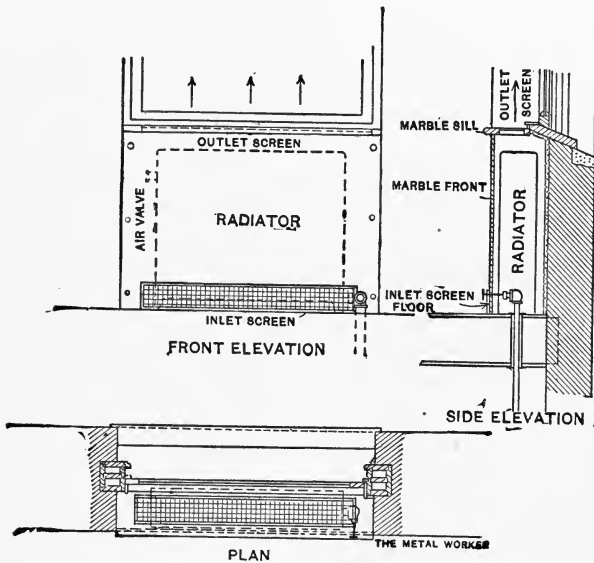

Fig. 16.—Plan and Front and Side Elevations, Showing Method of Concealing Radiator with Marble Wainscoting.

1.6 heat units. With this as a basis a steam radiator under 5 pounds pressure, corresponding to 228 degrees, surrounded by air at 70 degrees (neglecting the difference in temperature between the air near the top and the bottom of the radiator), will give off $(228 - 70 \text{ degrees}) \times 1.6$ heat units per square foot per hour = 253, commonly taken as 250. With hot water at an average temperature of 160 the heat given off is $(160 - 70) \times 1.6 = 144$, commonly taken at 150.

These are good average figures to use. If we go into the subject closely we note that low radiators are more effective than high ones and those of single column pattern are more effective than deeper radiators, since they radiate their heat more freely and air will circulate around them to better advantage.

Wall radiators and coils of pipe are still more effective, overhead coils, with pipes side by side, giving off more heat per square foot than those on walls with the pipes one over the other. The advantage in the location of the latter, however, more than offsets the greater efficiency of those placed overhead, as is common in mill heating. Coils may be based on 300 to 350 heat units per square foot per hour with low pressure steam, and wall radiators on about the same amount. Concealed radiators, like the one illustrated in Fig. 16, give off practically no heat by radiation, but heat the room by heating the air passing over them—that is, by convection. Such radiators should therefore be rated to give off not more than 200 heat units per square foot per hour, depending on the height and arrangement.

NOTES ON HEAT EMITTED BY DIRECT RADIATORS.

Professor Carpenter, in Vol. I, Transactions A. S. H. & V. E., states: "The capacity for heat transmission increases at a much higher rate than the difference of temperature. The efficiency of the radiator will be greatly increased by increasing the steam pressure or by forcibly bringing the air in contact with it. The heat emitted per hour under different conditions by the same radiator was found by tests to vary about 15 per cent., this variation being largely due to a difference in temperature and also to changes in velocity of air passing over the radiator.

"With radiators of the same form, but of different heights, the lower the radiator the more efficient. In the case of a Royal Union radiator 17 inches high, with practically the same amount of heating surface as another 37 inches high, 50 per cent. more heat was emitted by the low radiator. The radiator coefficient for a difference of temperature of 150 degrees is usually about 1.6 heat units; that for a 2-inch horizontal pipe 3.8 heat units; 1-inch pipe, 5.7 heat units.

"Radiators with one row of tubes are much superior to those of the same kind with two or more rows of tubes. The fact that

low radiators are more efficient than high ones would indicate that the tubes in the high radiators are too closely placed; that the air in its passage upward reaches nearly its maximum temperature in a short distance and from that point upward absorbs but little heat."

The average of many tests on ordinary cast iron radiators appears to confirm the figure of 1.6 heat units per square foot an hour per degree difference in temperature as a fair one to use.

Tests made by the City Engineer of Richmond, Va., on several types of radiators commonly used, gave results ranging from 1.43 heat units to 1.81 heat units per square foot an hour per degree difference in temperature. The average of the tests on five different makes of radiators was 1.68.

Monroe, in his book on "Steam Heating and Ventilation" states: "The writer found that under the conditions in his testing plant the 38-inch, 2-column cast iron radiator gave out 1.6 heat units per square foot per hour per degree difference of temperature, with an average difference of 147.5 degrees."

He states that "within the limits of ordinary radiator practice with steam temperatures from 212-230 degrees, and mean air temperatures from 40-70 degree, the coefficient of 1.6 will not vary more than 9 per cent. due to the difference in temperature between the steam and air. The radiator which has the most open space around its surface and the largest uninterrupted exposure to the surrounding air will give out the most heat per square foot under the same conditions. In compliance with this rule, other things being equal, narrow radiators are more effective than wide ones and low ones than high ones. Professor Cooley found that a single coil of horizontal pipes set side by side gives out 40 per cent. more heat per square foot than a two column cast iron radiator under the same conditions."

In the "Plumbers' and Fitters' Pocket Book," published by the International Correspondence Schools, 1905, a statement is made that the heat units emitted per hour per square foot of surface per degree difference in temperature amounts with 90 degrees difference (which would correspond approximately with hot water heating conditions), to 1.41 for radiators 40 inches high, 1.7 for radiators 24 inches high, 1.62 for single column radiators

40 inches high, and 2.22 for those 24 inches high. The figures taken in the same order for over 160 degrees difference in temperature corresponding practically to steam heat conditions would be 1.66, 1.98, 1.88 and 2.59.

The Fowler & Wolfe Mfg. Co.'s catalogue gives a summary of tests as follows:

TABLE VI.

Summary of Tests of various steam radiators made at Sibley College, Cornell University, by Messrs. Camp, Woodward and Sickles, mechanical engineers, under the direction of R. C. Carpenter, M.S.C.E., M.M.E. (This summary is the average of several consecutive tests made on these several radiators.)

These tests were all made in the same closed room under even temperatures and under same conditions.	F. & W. wall radiator. Standard 7-foot section tested.	Standard high 3-column cast iron radiator.	A standard high cast iron radiator with loops attached to base.	A standard high radiator made of 1-inch wrought iron pipe attached to cast iron base 3 rows wide.	A standard high cast iron 2-column radiator.
*B. T. U. heat radiated per hour per square foot of actual surface. Per degree difference in temperature.....	2.325	1.732	1.705	1.643	1.319
B. T. U. heat radiated per hour per rated square foot of surface. Per degree difference in temperature	2.400	1.712	1.594	1.266	1.266
Steam condensed per hour per actual square foot of heating surface. Pounds.	0.351	0.236	0.239	0.182	0.182

* B.T.U. = British thermal units, or heat units.

Reference is made in the Heine Safety Boiler Co.'s catalogue to the average of four experiments on the condensation in uncovered pipes which showed with an average steam pressure of 5 pounds gauge, 2.236 heat units per square foot per hour per 1 degree F. Other tests showed a loss of 2.812 for bare pipe.

Mr. A. R. Wolff gives 250 heat units per square foot per hour for ordinary cast iron radiators with steam from 3 to 5 pounds per square inch, and recommends about 60% of this amount for hot water heating.

The results of a number of radiator tests are given in Mills's book on "Heating & Ventilation," Vol. II., page 335. The heat

emitted from cast iron radiators, according to these tests, ranges from 1.4 for certain types of cast iron radiator, to 2.38 for single column wrought iron tube radiator. Heat given off by horizontal pipes is as follows: 1-inch pipe 2.73; 2-inch pipe 2.3; 3-inch pipe 2.33.

The following figures are taken from "Steam in Covered and Bare Pipes," by Paulding:

TABLE VII.
LOSS OF HEAT FROM PIPES.

Name of experimenter.	Size of pipe. Inches.	Temperature of steam. Deg. F.	Temperature of air. Deg. F.	B. T. U. per square foot per hour per 1 deg.
Barrus	2	325.2	56.6	3.01
Barrus	2	365.4	63.2	3.25
Barrus	10	365.3	73.6	3.18
Hudson-Beare	3.53*	358.0	67.0	3.10
130 pounds.....	2	354.7	80.1	3.13
Jacobus	2	300.6	71.2	2.78
Brill	8	344.5	75.5	2.71

* Actual outside diameter.

Since the heat given off is roughly proportional to the difference in temperature between the steam and the air in the room, radiators placed in rooms to be heated to a temperature lower than 70 degrees, say 50 degrees, will give off with radiators at

228 degrees $\frac{(228-50)}{(228-70)} \times 250$ heat units = about 280 heat units.

In this connection it may be well to remark that in computing boiler capacity one must remember that catalogue ratings are based on the radiators being placed in rooms at 70 degrees. The radiation must be reduced to equivalent surface when surrounded by air at 70 degrees temperature.

It has just been shown that in rooms at 50 degrees the radiators give off 280 heat units, against 250 heat units in 70-degree rooms; hence, a boiler rated for, say 2500 square feet will carry only $\frac{250}{280} \times 2500 = 2230$ square feet if the rooms are to be heated to only 50 degrees.

HEAT GIVEN OFF BY INDIRECT RADIATORS.

Indirect radiators of the pin or similar type, with extended surface, arranged somewhat as shown in Fig. 17, give off heat not

only in proportion to the difference in temperature between the steam and the surrounding air, but in proportion (though not directly) with the volume of air coming in contact with them.

The tests made some years ago by John H. Mills have been frequently quoted by writers on heating and ventilation. The writer has reduced these tests to a zero basis for the entering air, the data being given in the following table.

TABLE VIII.

THE HEAT UNITS GIVEN OFF PER SQUARE FOOT PER HOUR FROM INDIRECT PIN RADIATORS HAVING 40 PER CENT. PRIME SURFACE.—STEAM, 5 POUNDS PRESSURE; ENTERING AIR, 0 DEGREE F.

Cubic feet of air per hour passing over each square foot of heating surface.	Heat units given off per hour per square foot of extended surface.	Velocity in feet per minute between 10 square foot sections, having $\frac{1}{2}$ square foot air space between each two sections.
100	370	50
200	540	100
300	700	150
400	850	200
500	1,015	250
600	1,175	300
700	1,330	350
800	1,500	400

It is common to assume about 400 heat units to be given off per square foot an hour from ordinary indirect pin radiators with low pressure steam. Short vertical flues mean low velocities; higher ones give an increased air flow.

The table shows that where a good velocity between the sections may be secured their effectiveness is increased and less surface is required.

COMPUTING INDIRECT RADIATING SURFACE.

To illustrate the use of the table, suppose we have a room $20 \times 30 \times 12$ which it is desired to heat by indirect radiation and change the air every 12 minutes—contents equals 7200 cubic feet. With 5 changes per hour 36,000 cubic feet must be supplied. The heat loss by transmission, with two sides exposed, would be about 24,000 heat units per hour. The loss by ventilation would be $36,000 \times 1\frac{1}{4}$ ($1\frac{1}{4}$ representing the heat units carried away by each cubic foot of air escaping from a 70-degree room, with outside air at 0 degree) = 45,000. Adding these, the total heat loss is 81,000 heat units per hour. Assuming 400 heat units per

square foot of radiation per hour gives a trifle over 200 square feet of surface, or a ratio of 1 to 36 cubic feet. With 36,000 cubic feet per hour supplied the air admitted to the indirect radiators would be $36,000 \div 200 = 180$ cubic feet per square foot (neglecting the difference in volume between air at 70 degrees and at 0 degree). The table shows that with 200 cubic feet per square foot per hour 540 heat units are given off; hence we should expect

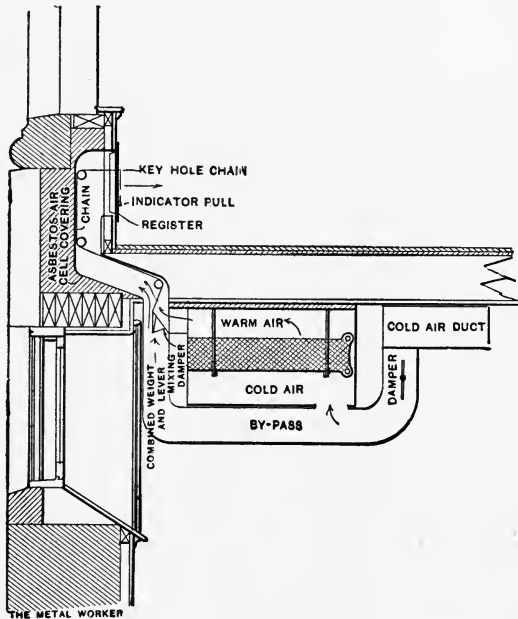

Fig. 17.—Indirect Radiator Connections.

that with 180 cubic feet about 500 heat units in round numbers would be given off, in which case only $81,000 \div 500 = 162$ square feet would be necessary. One must always be certain that the air space through the groups of radiators is considerably in excess of the area of flues connected therewith. The rule to allow 2 square inches of flue area to the first floor, $1\frac{1}{2}$ to the second floor and $1\frac{1}{4}$ to the third and fourth floors is simple, and gives good results in dwelling house work when the radiation is properly proportioned. That is just the difficulty, however, for in case of a mistake in the radiation a second mistake follows in the flues.

Taking $1\frac{1}{2}$ square inches of flue area per square foot of indirect radiating surface as a fair average for a house, a bench or stack of 100 square feet would have flues aggregating 150 square inches. The flue area between the sections would be about 480 square inches, or over three times the flue area; thus, common practice dictates that the velocity between the sections of pin radiators shall be only about one-third that in the flues. The rule to make the indirect surface 50 per cent. more than the direct radiation that would be required may be shown on a heat unit basis to be very nearly true under certain conditions. For example,

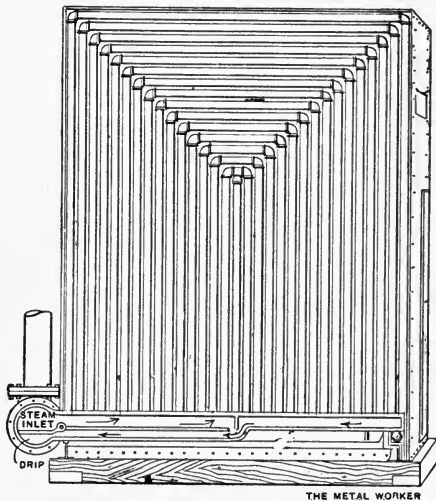

Fig. 18.—Blower System Heater.

take a corner room $16 \times 20 \times 10 = 3200$ cubic feet, the heat loss from which is 14,400 heat units per hour. With direct steam radiation rated at 250 heat units 14,400 \div 250 = 58 square feet would be required. Now, to heat the same room by indirect radiation at 400 heat units per square foot, the air to enter the room at 120 degrees, with 0 degree outside, about 86 square feet would be required, computed as follows:

One cubic foot of air at 120 degrees weighs 0.068 pound. Its specific heat is 0.238, therefore the heat units brought in by a cubic foot of air at 120 degrees is $0.068 \times 120^\circ \times 0.238 = 1.94$.

Of this only $\frac{50}{120}$ is available to offset the loss of heat by transmission, the other $\frac{70}{120}$ escaping with the air leaking out at 70 degrees temperature. $\frac{50}{120} \times 1.94 = 0.810$ heat unit. To make good the loss of 14,400 heat units per hour by transmission $14,400 \div 0.810 = 17,800$ cubic feet of air per hour at 120 degrees must be supplied. Each cubic foot brings in 1.94 heat units; total equals $17,800 \times 1.94 = 34,500$ heat units, which divided by 400

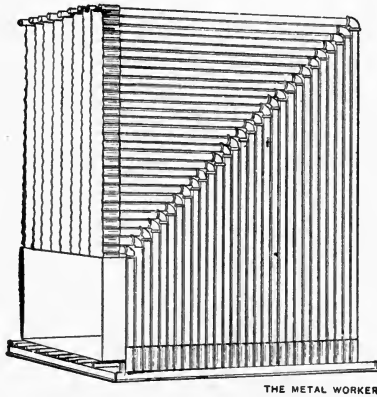

Fig. 19.—A Heater for Blower Use.

gives 86, an amount almost exactly 50 per cent. in excess of the direct radiation required.

HEAT GIVEN OFF BY HEATERS COMBINED WITH FANS.

It is not uncommon to secure an emission of 1500 to 2000 heat units or more per square foot of pipe coils when zero air is entering the heater at a velocity of 1000 to 1200 feet per minute, measured between the pipes and the steam is 2 to 5 pounds gauge pressure. See Figs. 18 and 19.

The heat given off per square foot by supplementary heaters or reheaters, as shown in Fig. 20, with which air at, say, 50 to 70 degrees from the main tempering coils comes in contact would be not far from 1000 to 1200 heat units in the case of low pressure steam. The velocity of the air and the depth of heaters—

that is, the number of coils of pipe they contain—have much to do with their efficiency, which depends chiefly on the steam pressure. Assuming a main tempering coil arranged to have the air blown through it by a fan or blower, as in Fig. 21, or to have the air drawn through, as shown in Fig. 22, to give off 2000 heat units per square foot per hour, what amount of surface would be necessary to raise the temperature of 30,000 cubic feet per minute 70 degrees from zero?

Since one heat unit will raise the temperature of approximately 50 cubic feet of air from 0 degree through 1 degree, to

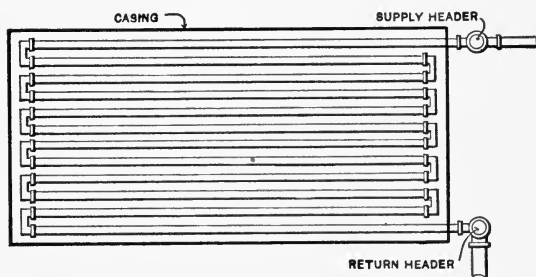

Fig. 20.—Supplementary Heater or Reheater.

raise $30,000 \times 60 = 1,800,000$ cubic feet per hour 70 degrees, would require $\frac{1,800,000 \times 70}{50} = 2,520,000$ heat units, which could be obtained by using a heater of $\frac{2,520,000}{2000} = 1260$ square feet, or about 3600 lineal feet of 1-inch pipe.

TEMPERATURE OF AIR REQUIRED TO HEAT ROOMS BY INDIRECT RADIATION.

It may be desired to predetermine the temperature that must be secured at the air inlet to warm a room.

Take a corner schoolroom, for example, $28 \times 32 \times 12$, with 30 per cent. glass and exposed north and west.

The equivalent glass surface, rating the wall as equivalent to one-quarter as much actual glass surface, will be 342 square feet.

The heat lost through same per hour will be $342 \times 85 \times 1.25 = 36,340$ heat units. (1.25 being the factor for N. or W. exposure.)

With the standard air supply to a 50-pupil room of 1500 cubic

feet per minute the loss of heat by leakage—that is, by the removal of air through the ventilating flues—will be $60 \times 1500 \times 1\frac{1}{4}$ (since $1\frac{1}{4}$ heat units are removed by each cubic foot of air escaping from a room at 70 degrees when the outside temperature is at 0 degree) = 112,500 heat units per hour. Total

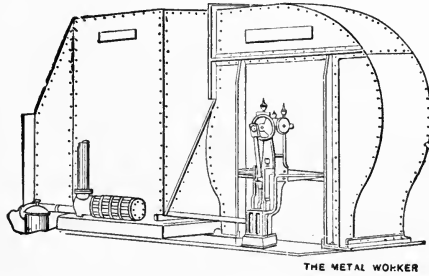

Fig. 21.—A Fan Blowing Air through Heater.

heat loss equals 148,840. To make good the loss of heat through walls and glass the 90,000 cubic feet of air per hour supplied to the room (the volume being based on 70-degree temperature)

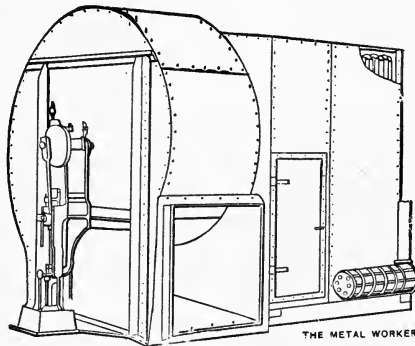

Fig. 22.—Fan or Blower Drawing Air through Heater.

must be superheated above the room temperature an amount equivalent to the 36,340 heat units transmitted through walls and glass.

The weight of 90,000 cubic feet of air at 70 degrees is about $90,000 \times 0.075 = 6750$ pounds. The specific heat of air is 0.238—that is, one heat unit will raise the temperature of about 4 pounds of air 1 degree.

Therefore, 36,340 heat units would raise the temperature of $36,340 \times 4 = 145,360$ pounds of air 1 degree, or would raise the

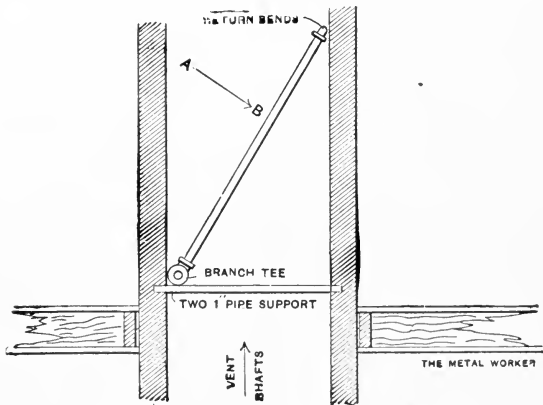

Fig. 23.—Section through Vent Flue, Showing Aspirating Coil.

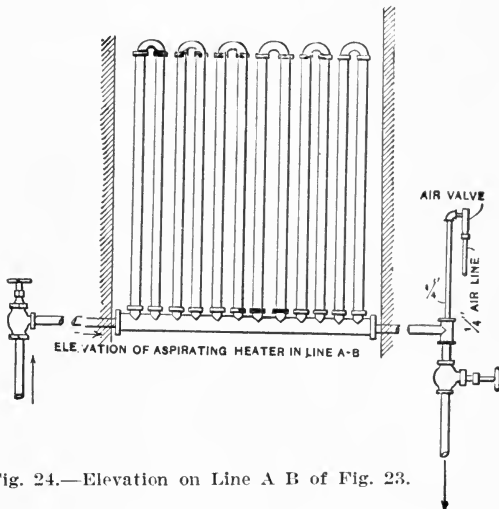

Fig. 24.—Elevation on Line A B of Fig. 23.

temperature of 6750 pounds of air; $145,360 \div 6750 =$ about 22 degrees.

That is, the air would have to be superheated at least 22 degrees above the room temperature of 70 degrees to maintain the room at that temperature under the conditions stated—viz., with a change of air about every eight minutes. As a matter of

fact, with the indirect system there is a considerable difference between floor and ceiling temperatures in high studded rooms, which means that if 70 degrees is to be maintained near the floor a considerably higher temperature must be maintained above, with a consequent increase in the loss of heat by transmission; therefore, instead of 92 degrees, as above computed, based on an average temperature at walls of 70 degrees, the inlet temperature would probably have to be kept at not less than 100 degrees in zero weather, especially if the windows were not tightly fitted.

SIZE OF ASPIRATING HEATERS OR COILS.

To compute the size of heaters or coils to be placed in ventilating flues, as shown in section and elevation in Figs. 23 and 24, to produce an aspirating effect in a system of ducts, as shown by plan and elevation in Figs. 25 and 26, we may proceed as follows: Suppose it is desired to remove 3000 cubic feet of air per minute from a room. Knowing the size and height of the flue, for example, 10 square feet area and 40 feet high above where the coil is to be placed, look up the flue velocities in Table IX—the excess of temperature over that outdoors that must be maintained in the flue to produce the required velocity. In this case the velocity must be $3000 \div 10 = 300$ feet per minute, and the excess temperature required, taken from Table IX, is 20 degrees.

To heat 3000 cubic feet per minute 20 degrees would require $\frac{3000 \times 60 \times 20}{55} = 65,454$ heat units per hour (55 representing the number of cubic feet of air heated 1 degree by 1 heat unit).

With an aspirating heater made up of ordinary pin radiators, giving off, say, 400 heat units per square foot of extended surface per hour, and this would be a fair allowance, the surface required would be $65,454 \div 400 = 163$ square feet. The sections should be coupled together with extra long nipples.

One should always compute the air space through heaters to make sure it is ample.

The free area between the sections of the heater should be at least 20 per cent. greater than the flue area, to allow for the increased friction of the air in passing over the pins or extended surface. A temperature rise of 20 degrees in the ventilating flues to produce an aspirating effect would require the use of very

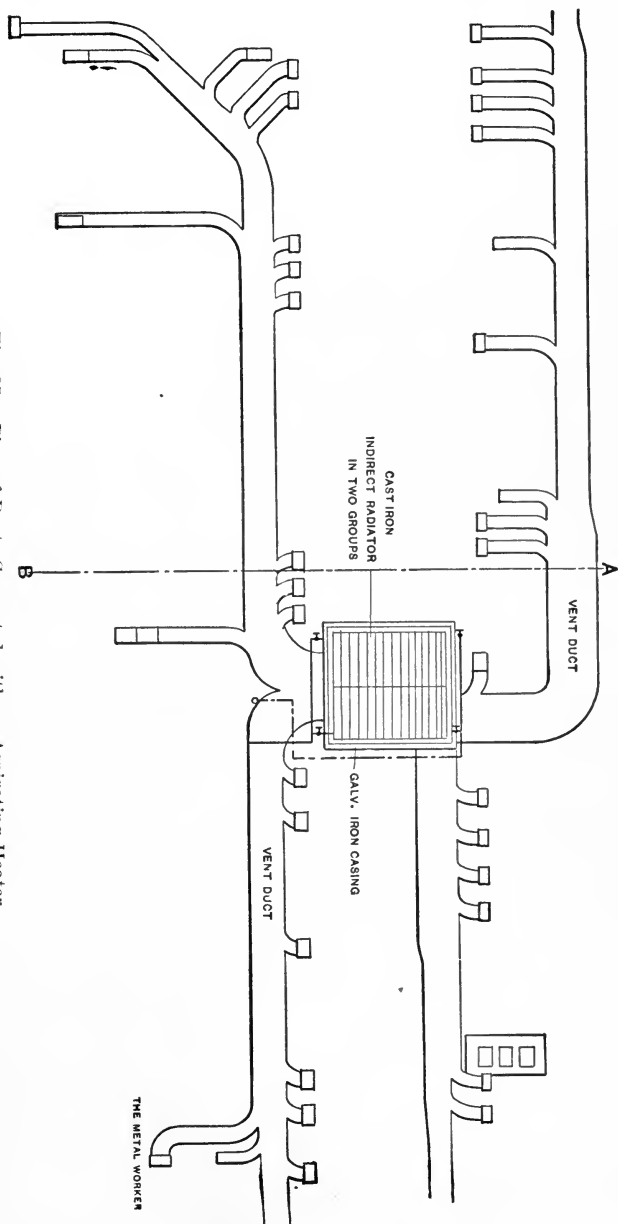

Fig. 27.—Plan of Ducts Connected with an Aspirating Heater.

large heaters and coils, or radiators. It is therefore seldom that a temperature rise of more than 10 degrees is provided for.

This means that a 40-foot vent flue proportional to handle the required volume of air with a 20-degree excess of temperature in the flue over that outdoors will work without the assistance of a coil up to 50 degrees outside temperature. If the outdoor air is 60 degrees then 10 degrees of the 20 degrees excess is provided by the air entering the vent flue from the room at 70 degrees, the balance, or other 10 degrees, to be furnished by the aspirating coil.

Should the weather reach 65 degrees outside the excess in the flue would be 15 degrees, and a slight falling off in flue velocity would take place, this falling off increasing as the outside temperature approaches 70 degrees, when windows may be opened and ample natural ventilation secured. When possible it is far preferable to use a fan in place of aspirating coils to produce the desired removal of air. Positive results are secured and the air may be handled at less cost.

It is impossible as a rule to install pin radiators in flues just above the ventilating registers in rooms without cutting down the flue area too much. The radiators must therefore be placed in the attic.

TABLE IX.*

THE APPROXIMATE VELOCITY OF AIR IN FLUES OF VARIOUS HEIGHTS.
Outside temperature, 32 degrees. Allowance for Friction, 50 per cent. in flue 1
Height
of flue. square foot in area.

Feet.	—Excess of temperature of air in the flue over that outdoors.—													
	10°	20°	30°	40°	50°	60°	70°	80°	90°	100°	120°	140°		
5.....	77	111	136	159	179	199	216	234	250	266	296	325		
10.....	109	156	192	226	254	281	306	330	354	376	418	460		
15.....	133	192	236	275	312	344	376	405	432	461	513	565		
20.....	154	221	273	319	359	398	434	467	500	532	592	650		
25.....	173	248	305	357	402	445	485	522	560	595	660	728		
30.....	189	271	334	390	440	487	530	572	612	652	725	798		
35.....	204	293	360	423	475	527	574	620	662	705	783	862		
40.....	218	311	386	452	508	562	612	662	707	753	836	920		
45.....	231	332	408	478	538	597	650	700	750	800	887	977		
50.....	244	350	432	503	568	630	685	740	790	843	935	1,030		
60.....	267	383	473	552	622	690	750	810	865	923	1,023	1,125		
70.....	289	413	510	596	671	746	810	875	935	995	1,105	1,215		
80.....	308	443	545	638	717	795	867	935	1,000	1,065	1,182	1,300		
90.....	327	470	578	678	762	845	920	990	1,060	1,130	1,252	1,380		
100.....	345	495	610	713	802	890	970	1,045	1,118	1,190	1,323	1,455		

* Reprinted from "Furnace Heating," by same author.

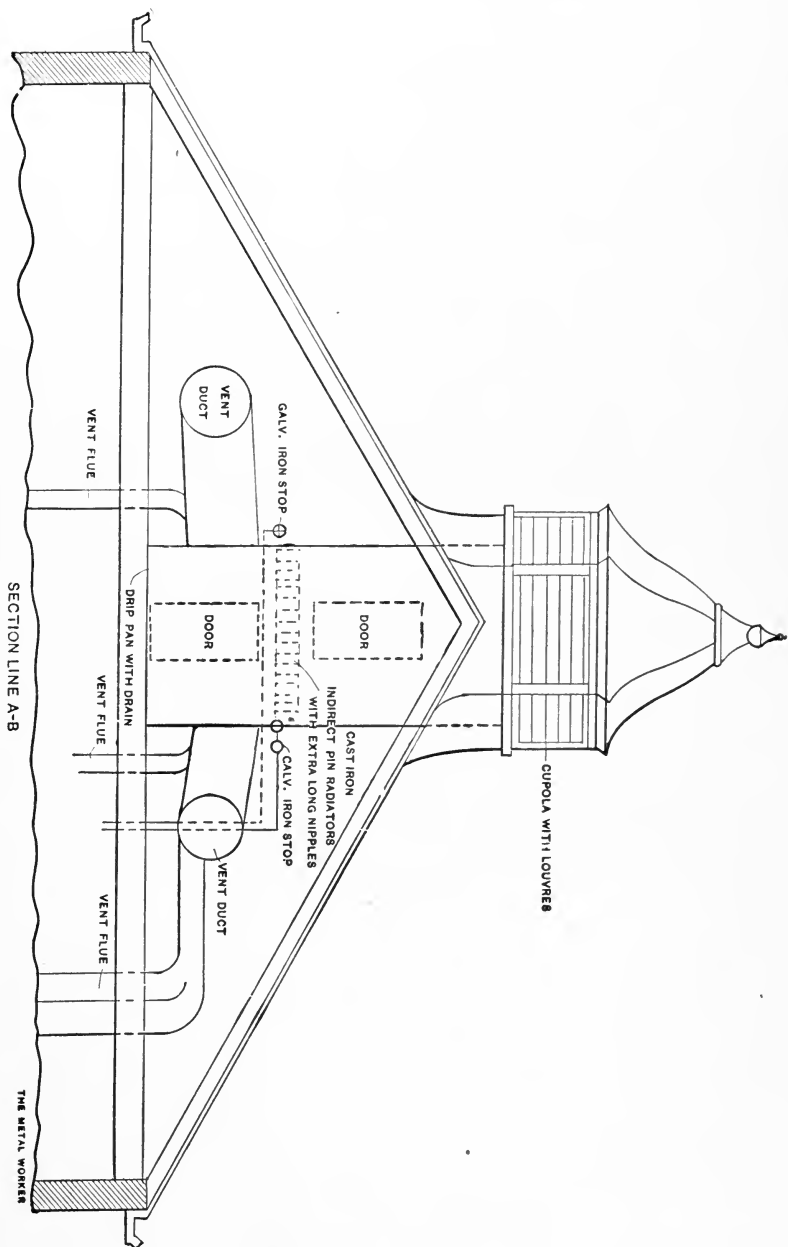

Fig. 26.—Elevation of System on Line A B of Fig. 25.

More radiation must be used, however, since the chimney effect of the flue is decreased the nearer the top the aspirating heater is placed.

Where small volumes of air are to be removed coils or lines of pipes may be used to advantage in place of cast iron radiators, care being taken not to block off too much of the flue area. Such coils may be computed on a basis of 600 heat units or more per square foot per hour, depending on the flue velocity.

CHAPTER VII.

THE LOSS OF HEAT BY TRANSMISSION, COMPUTING RADIATION, HORSE POWER REQUIRED.

The following tables have been computed from data presented in a series of articles on "German Formulas and Tables for Heating and Ventilating Work," by Prof. J. H. Kinealy, beginning in *The Metal Worker* of June 18, 1898. The values given include those for a greater variety of building materials than the writer has seen published elsewhere. The values for glass and brick work agree pretty closely with those commonly used in this country.

TABLE X.

LOSS OF HEAT THROUGH BRICK WALLS OF APPROXIMATELY THE THICKNESS STATED.
70 degrees inside, 0 degree outside.

Thickness of wall, inches.....	8	12	16	20	24	30	36
Heat units per square foot per hour..	24	21	18	16	14	12	10

Tables showing the relative transmitting power of solid brick walls and those with air spaces about 2.4 inches wide show that those with the air space transmit about 15 to 20 per cent. less heat than the solid walls. This applies only to walls, say, 8 to 16 inches thick. With thicker walls the saving due to an air space is much less.

TABLE XI.

LOSS OF HEAT THROUGH STONE WALLS, RUBBLE OR BLOCK MASONRY.
70 degrees inside, 0 degree outside.

Thickness of wall, inches.....	12	16	20	24	28	36	44
Heat units per square foot per hour..	31	27	25	21	19	17	14

The values given are for sandstone; about 10 per cent. should be added for limestone.

TABLE XII.

LOSS OF HEAT THROUGH PINE PLANKS.
70 degrees inside, 0 degree outside.

Thickness of planking, inches.....	1½	2	2½	3
Heat units per square foot per hour.....	21	18	16	14

TABLE XIII.

LOSS OF HEAT THROUGH WINDOWS AND SKYLIGHTS AND THROUGH OUTSIDE WALLS OF FRAME CONSTRUCTION, EXPRESSED IN HEAT UNITS PER SQUARE FOOT OF EXPOSED WALL PER HOUR.

70 degrees inside, 0 degree outside.

	Heat units per square foot per hour.
Single window.....	77
Single window, double glass.....	43
Double window.....	32
Single skylight.....	81
$\frac{3}{4}$ -inch sheathing and clapboards.....	20
$\frac{3}{4}$ -inch sheathing, paper and clapboards.....	16

Professor Kinealy states: "These can hardly be considered much more than rough approximations on account of the uncertainty due to leakage."

TABLE XIV.

LOSS OF HEAT, EXPRESSED IN HEAT UNITS PER SQUARE FOOT OF SURFACE PER HOUR, THROUGH PARTITIONS, FLOORS AND CEILINGS SEPARATING WARM ROOMS AT 70 DEGREES FROM COLD ROOMS AT 40 DEGREES.

	Heat units.
Ordinary stud partition, lath and plaster one side only.....	18
Ordinary stud partition, lath and plaster both sides.....	10
Ordinary lath and plaster ceiling separating unheated space from heated rooms	18
Floor, single, thickness $\frac{3}{4}$ inch, warm air above and cold space below:	
(a) No plaster beneath joists.....	13
(b) Lath and plaster beneath joists.....	8
Floor, double, thickness $1\frac{1}{2}$ inches, warm room above and cold space below:	
(a) No plaster beneath joists.....	9
(b) Lath and plaster beneath joists.....	5

The heat losses stated in the tables are to be increased as follows, based on the practice of different German engineers:

TABLE XV.

	Per cent.
For northeastern, northwestern, western or northern exposure.....	20 to 30
For rooms 12 to $14\frac{1}{2}$ feet high.....	$6\frac{1}{2}$
For rooms $14\frac{1}{2}$ to 18 feet high.....	10
When the heating is continued during the day only.....	10
When the building is allowed to become thoroughly chilled at night.....	30
When the building remains for long periods without heat.....	50

COMPUTATION OF HEAT LOSSES AND RADIATION.

To illustrate the use of the German values given, suppose it is desired to compute the amount of steam radiation required to



heat a corner room 14 x 16 x 10 feet, exposed to the north and west, located below a heated room and over an unheated room; floor to be double, with under side of floor joists lathed and plastered; outside walls 12 inches, brick; glass 20 per cent. of the exposure, equal to 60 square feet, net wall equaling 240 square feet:

Heat losses:	
Wall, 240 x 21 heat units.....	5,040
Glass, 60 x 77 heat units.....	<u>4,620</u>
Total.....	<u>9,660</u>
Heat loss x exposure factor = 9,660 x 1.25.....	<u>12,075</u>
Heat loss through floor, 224 x 5.....	<u>1,120</u>
Total heat loss.....	<u>13,190</u>

Direct radiating surface is equal to the total heat loss divided by heat given off per square foot of radiating surface—viz.: 250 heat units, or $13,190 \div 250 = 53$ square feet, giving a ratio of about 1 square foot to 43 cubic feet of space. It will be noted that no allowance has been made in the above example for air leakage. Professor Kinealy points out that the German engineers appear to make no allowance for this item, except as taken into account by the percentage addition for exposure. Some engineers in this country allow for the accidental leakage by assuming a certain rate of air change, say once an hour, for all rooms.

In large rooms having little exposure in proportion to the contents the loss of heat due to leakage, based on an hourly rate, is often as great as that through the walls, if not greater, which would call for more radiation than is found necessary in practice.

The question of leakage is an important one and requires good judgment for its proper determination. In preference to making a fixed allowance for leakage, based on the cubic contents, the writer has found it more satisfactory to consider the leakage to be sufficiently allowed for by the exposure factors of 1.25 for north or west and 1.15 for east, especially when using factor 77 or 85 for glass, and to make a separate allowance for the effect of the cubic contents on the heating of a room by adding to the loss of heat by transmission an amount of heat equal to the cubic contents in feet multiplied by 1-3 for room with two exposures, and the cubic contents multiplied by 2-3 for rooms with one exposure. This allowance will be found sufficient to provide for

reheating where the rooms are allowed to become somewhat chilled at night.

The reason for making a greater allowance for reheating in the case of rooms with one exposure than of those with two exposed walls is that the rate of transmission is somewhat greater per square foot through the single exposed wall having three partition walls radiating heat to it than through the same wall area of a corner room having only two interior walls radiating heat to the outer ones.

Furthermore the three inside walls on account of their greater surface, require more heat to warm them in a given time than do the two inside walls of a corner room of the same size, therefore, in order that corner rooms and single exposure rooms shall heat in approximately the same time, a greater allowance for reheating should be made for the latter.

COMPUTING DIRECT RADIATION ON THE HEAT UNIT BASIS.

Perhaps the most time consuming operation in connection with the work of the heating engineer or contractor is the computation of radiating surface. Innumerable rules have been devised, good, bad and indifferent, but the subject appears to have simmered down to the simple proposition that if the wall and glass surface and the required air change are known the heat losses due to transmission and leakage may be readily determined, and this total divided by the heat given off per hour per square foot of radiating surface gives the amount of radiation required.

The German values for the heat transmitting power of various substances of different thicknesses have been widely used since they were first introduced by A. R. Wolff. Tables or charts giving these values may be found in Kent's "Mechanical Engineers' Pocket Book" and in many trade catalogues. Values closely approximating these have been stated. The French values, based on the investigations of Pécelet and introduced by Professor Carpenter, are in some cases considerably lower than those just mentioned, his value or coefficient for glass being 70, Wolff's being 85. Furthermore, Carpenter assumes a certain air change per hour by leakage in rooms heated by direct radiation, whereas Wolff provides for this loss by adding a certain percentage to

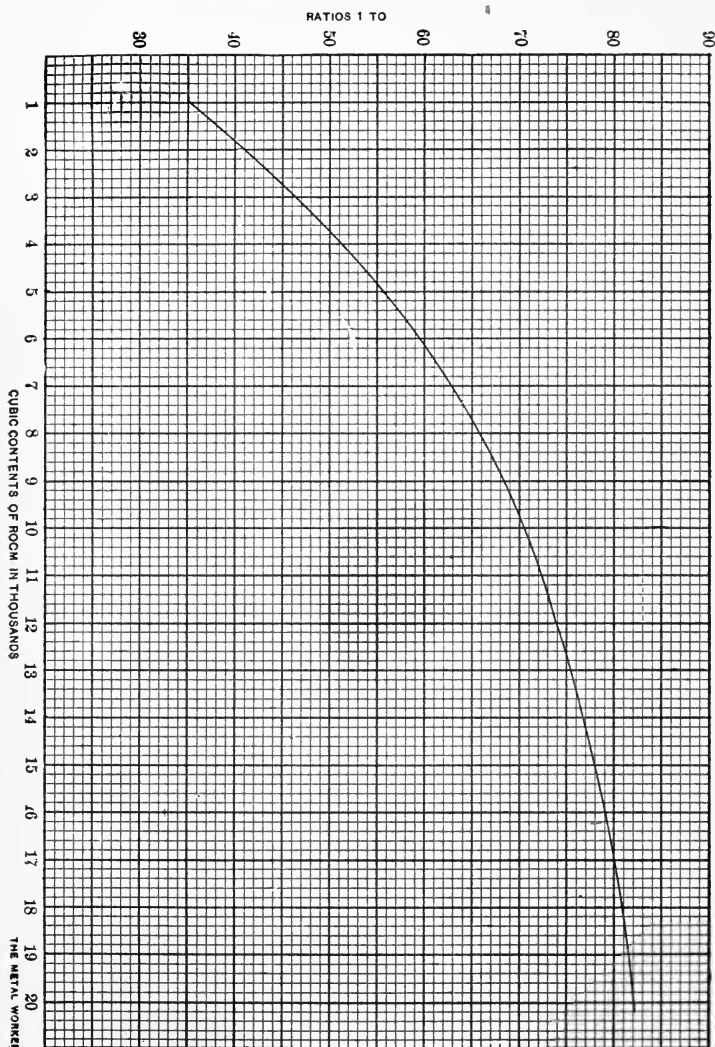

CHART I.

Ratios for DIRECT STEAM Radiating Surface in Rooms with TWO SIDES EXPOSED Toward the North and West, with Glass Surface Aggregating 20 Per Cent. of Total Exposure.

For northeast corner rooms use ratio 5 per cent. greater than given by chart.
 For southwest corner rooms use ratio 10 per cent. greater than given by chart.
 For southeast corner rooms use ratio 15 per cent. greater than given by chart.

the heat losses through walls and glass. Of course, where the leakage is great, as in rooms provided with ventilating flues, it is allowed for independently.

Admitting that the wall and glass surface affords the best basis on which to compute the radiating surface, it frequently happens in a contractor's office that insufficient time is given in which to lay out the work on this basis and prepare a bid. In house heating work especially some shorter method must often be used for the reason stated. In such cases an experienced man may be able to hit pretty close to the mark by "thumb rule," but, while quick, this method is a rather rough one.

Some simple method that will give reasonably accurate results that may be quickly arrived at is needed by many contractors. The author prepared, and has for several years used, the accompanying charts, Nos. 1 and 2, for computing direct steam and 3 and 4 for direct hot water radiation, the curves representing the mean or average of the German and French values with these modifications:

To the heat loss through walls and glass, based on German values, has been added a certain amount to allow for reheating the air in the rooms in case they should become chilled.

To the heat losses by transmission, computed on the French basis, has been added an amount representing the heat units escaping by a leakage of air equal to the contents of the room once each hour.

The tables are based on a glass surface equal to 20 per cent. of the total exposure. This the author has found to be a fair allowance; some rooms may have more than this amount, but an excessive glass surface is readily detected in inspecting plans and may be allowed for by adding to the radiating surface given by the chart an amount of radiation equal to about one-third of the excess of glass surface over the 20 per cent. on which the charts are based.

For example: If the total exposure is 400 square feet and the glass surface 120 square feet, or 40 square feet in excess of the glass surface based on 20 per cent. of the exposure, 13 square feet, being one-third of 40, should be added to the radiation computed by the chart.

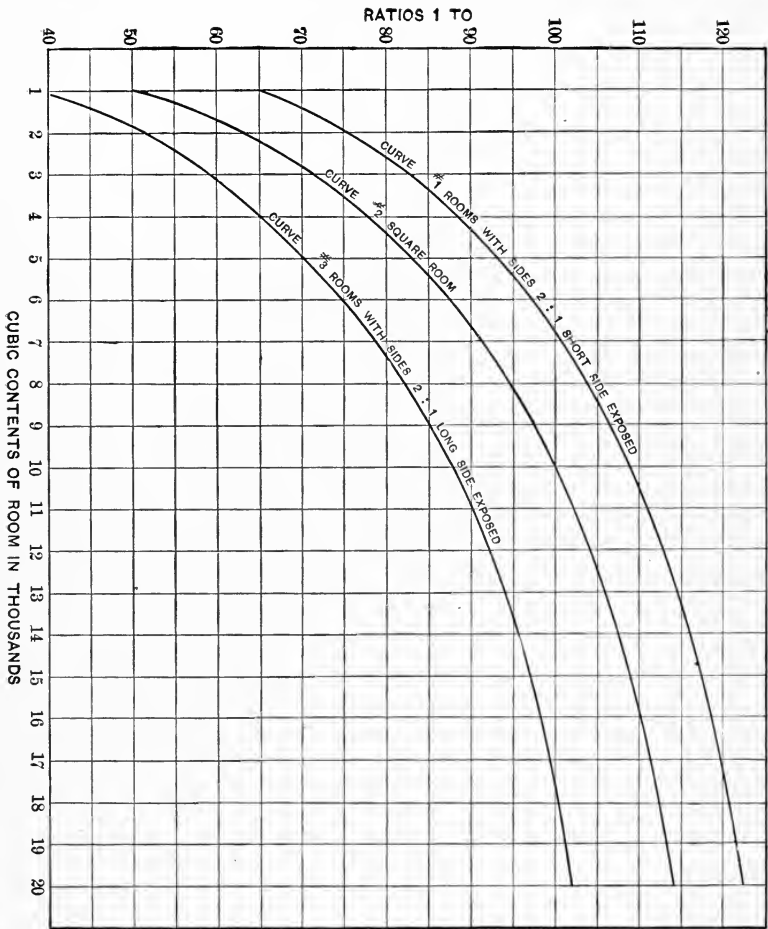

CHART 2.

Ratios for DIRECT STEAM Radiating Surface in Rooms Having Only ONE SIDE EXPOSED Toward North or West, with Glass Surface Aggregating 20 Per Cent. of Total Exposure.

Curve 1 is for rooms having length to width as 2 to 1, with short side exposed.

Curve 3 is for rooms having length to width as 2 to 1, with long side exposed.

Curve 2 is for square rooms with one side exposed.

For rooms with east, south or southeast exposure use ratio 10 per cent. greater than chart.

For rooms with southwest or northeast exposure use ratio 5 per cent. greater than chart.

Chart No. 1 shows a curve from which the proper ratios of steam heating surface to cubic contents may be determined for rooms with two exposed sides. The curve was computed for square rooms. Rectangular rooms of good proportions, however, have but little more exposed wall surface in proportion to their contents, and unless they are unusually long and narrow the ratio given by the chart may be safely used. The contents expressed in thousands of cubic feet is stated on the lower line and the ratio of radiating surface to contents is given in the vertical line at the left of the chart.

Example: What radiating surface should be used in a corner room 16 x 19 x 10 feet, having 3040 cubic feet? Just to the right of the 3000 line is a point representing the contents of 3040 cubic feet. Note where a line drawn vertically through this point would intersect the curve. In the left hand column this point of intersection is the ratio sought. The ratio in this case is about 1 to 47. The contents (3040) divided by this ratio gives 63 square feet of direct radiating surface.

Chart No. 2, for rooms with one exposure, contains three curves, one for rooms with sides in the proportion of 2 to 1 (24 x 12 feet, for example), having the long side exposed; one for similar rooms with the short side exposed and one for square rooms. Obviously it makes a great difference whether the long or the short side of a room is exposed.

For rooms having sides in the proportion of $1\frac{1}{2}$ to 1 (15 x 10 feet, for example), with the long side exposed, compute the contents and proceed as explained in connection with Chart No. 1, selecting a point in Chart 2 midway between curve 2 and curve 3 on the vertical line corresponding with the contents. The proper ratio will be found in the left hand column opposite this midway point.

With rooms like the one described, but having the short side exposed, select a point midway between curve 1 and 2.

Example: What amount of steam radiating surface is required in a room 12 x 18 x 10 feet, having the 12-foot wall exposed? Contents 2160 cubic feet. On Chart 2 follow up the line representing the contents to a point midway between curves 1 and 2, then out horizontally to the left hand column. The ratio there found is

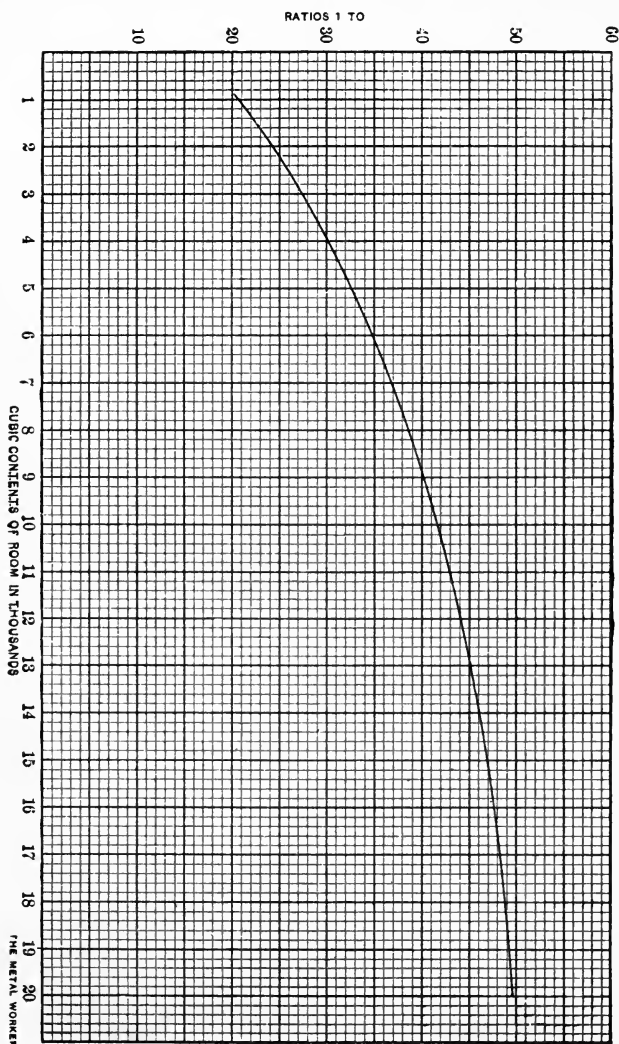

CHART 3.

Ratios for DIRECT HOT WATER Radiating Surface, Open Tank System, in Rooms with TWO SIDES EXPOSED Toward the North and West, with Glass Surface Aggregating 20 Per Cent. of Total Exposure.

For northeast corner rooms use ratio 50 per cent. greater than chart.

For southwest corner rooms use ratio 10 per cent. greater than chart.

For southeast corner rooms use ratio 15 per cent. greater than chart.

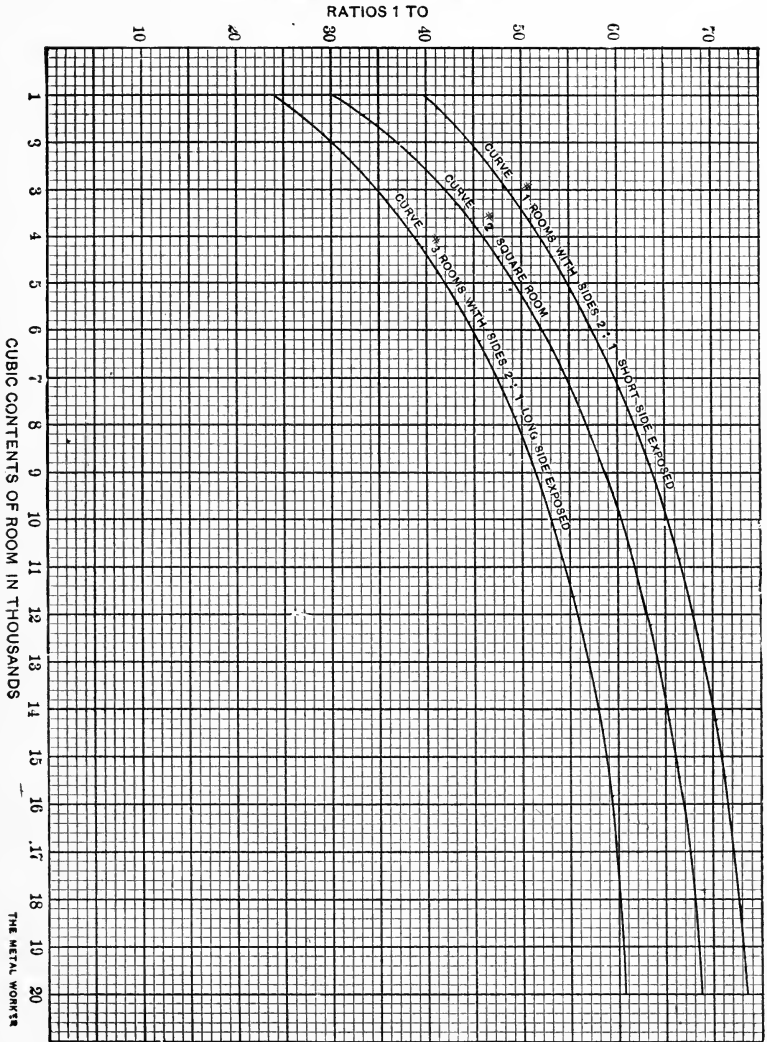

CHART 4.

Ratios for DIRECT HOT WATER Heating Surface, Open Tank System, in Rooms with Only ONE SIDE EXPOSED Toward the North or West, with Glass Surface Aggregating 20 Per Cent. of the Total Exposure.

Curve 1 is for rooms having length to width as 2 to 1, with short side exposed.

Curve 3 is for rooms having length to width as 2 to 1, with long side exposed.

Curve 2 is for square rooms, with one side exposed.

For rooms with east, south or southeast exposure use ratio 10 per cent. greater than chart.

For rooms with southwest or northeast exposure use ratio 5 per cent. greater than chart.

about 1 to 72, and the radiating surface $2160 \div 72 = 30$ square feet.

With this explanation of charts No. 1 and No. 2 for steam heating, the use of charts No. 3 and No. 4 for hot water heating will be readily understood without further examples.

THE BOILER HORSE-POWER AND RADIATING SURFACE REQUIRED TO HEAT ISOLATED BUILDINGS.

It is of interest to compute on a heat unit basis the boiler horse-power necessary to heat buildings under the conditions stated in connection with Chart 6.

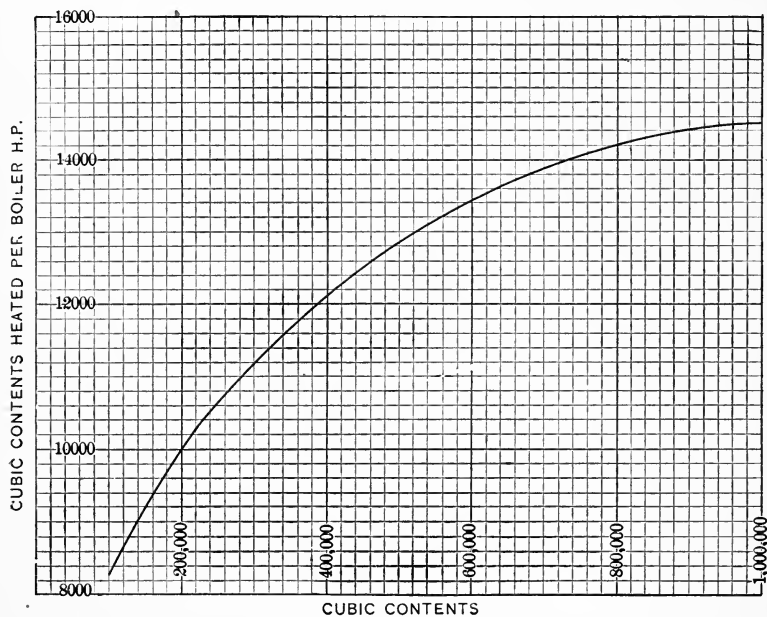

Chart 5.—Space Heated Per Boiler Horse-Power in Isolated Buildings Under Conditions Stated.

Chart No. 5 shows by the curve the increased space that may be warmed per boiler horse-power in large buildings over that in smaller ones, since the former have less exposed surface per unit of contents.

Chart No. 6 is based on buildings ranging in size from 100,000 to 1,000,000 cubic feet and in height from 20 to about 60 feet,

according to the size. The buildings are assumed to be rectangular in plan, the length being twice the breadth in each case. The glass surface is assumed to be one-third of the total exposure; the equivalent glass surface of the roof is taken as one-tenth the total area of same. An allowance for reheating the buildings was made equivalent to an amount of heat that would raise a volume of air equal to the contents 20 degrees in one hour. This amount of heat would not actually raise the temperature of the air in the building that amount in the time stated, since the walls and machines or what not in the rooms must have their temperature raised as well as that of the air, and would absorb a large portion of the heat. The greater the amount of material in the rooms the less will be the fluctuation in temperature with intermittent heating, since the machinery or goods that become thoroughly warmed during the day, when surrounded by air at, say, 60 to 70 degrees temperature, store up heat which is given off during the night or at times when steam is shut off.

For direct radiating systems the charts will be of service in checking roughly the boiler horse-power required. They apply only to buildings exposed on all sides under the conditions stated as to glass surface, exposure, etc. For other conditions due allowances must be made.

On the basis of, say, 85 square feet of radiating surface per boiler horse-power, mains and risers to be computed as radiating surface unless covered, the horse-power indicated in Chart No. 6, multiplied by 85, gives roughly the square feet of radiating surface necessary for buildings of contents stated. For example: A building of 200,000 cubic feet requires 20 horse-power, per chart No. 6 = $20 \times 85 = 1700$ square feet of radiating surface, a ratio of approximately 1 to 120 cubic feet. For 400,000 cubic feet, radiating surface = about $33 \times 85 = 2805$, giving a ratio of 1 to 143 cubic feet, and so on.

Of course, the above is to be considered as only a rough approximation. The figure 85 is perhaps too conservative. For accurate work the wall and glass surface must be computed.

SIZE OF HEATERS WITH BLOWER SYSTEMS.

With the blower system the inleakage of cold air will be somewhat diminished by the pressure in the rooms maintained by the

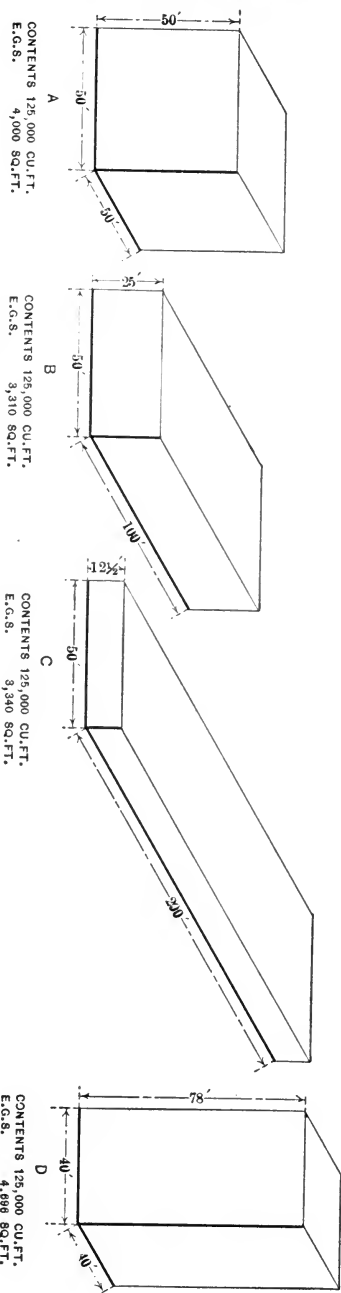

Fig. 26A.—Showing Variation in Exposure in Buildings of Equal Cubic Contents.

fan. This pressure is scarcely measurable, however, and its effect in preventing inleakage of cold air will be neglected in this discussion. With air supply at 140 degrees and building at 70 degrees, half the heat supplied is carried away by the air escaping at 70 degrees, the other half being lost by transmission through walls, windows and roof. Under these conditions twice as much heat is necessary as with direct radiation.

If the frequent change of air incident to the blower system is necessary, or if ample exhaust steam is available, well and

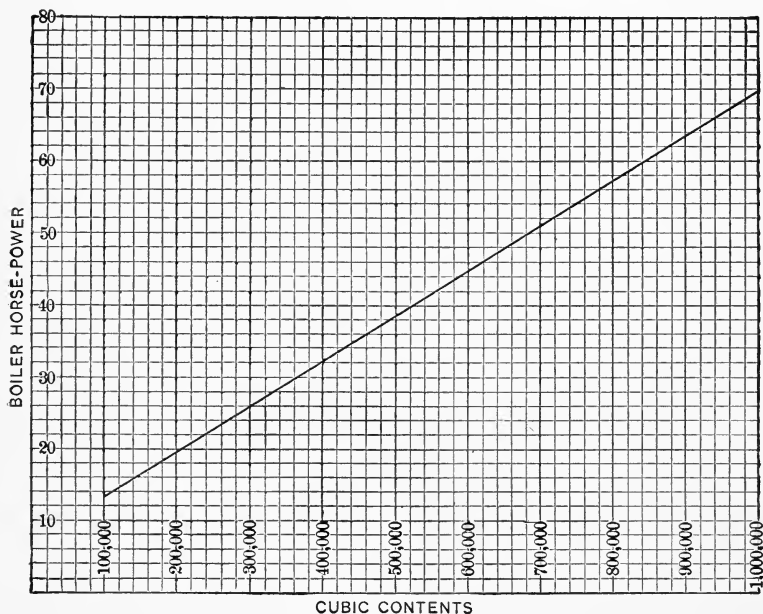

CHART 6.

Showing Boiler Horse-Power for Isolated Building Under Conditions Stated.

good; otherwise the loss of heat over direct radiation is a serious one.

Since a building with the blower system, under the conditions stated, taking air from the outside, will require twice as much heat as with direct radiation, the boiler horse-power shown in Chart No. 3 must be doubled; for example, a building of 200,000 cubic feet will require about $2 \times 20 = 40$ horse-power, and on the basis of 50 lineal feet of 1-inch pipe in the heater per horse-power, a

not uncommon allowance, a 2000 lineal foot heater would be required.

With other conditions than 140 degrees, 70 degrees and zero, as stated above, greater or less boiler horse-power would be required with lower or higher inlet temperatures, respectively. A much higher inlet temperature than 140 degrees is not to be generally recommended. With the blower system the heater pipes, with low pressure steam and ordinary velocities of air between them, are generally rated to give out 2000 heat units or more per square foot an hour, or, say an average of 600 heat units per lineal foot of 1-inch pipe, corresponding to 55 lineal feet per horse-power.

RELATIVE LOSS OF HEAT FROM BUILDINGS HAVING THE SAME
CUBIC CONTENTS.

The relative loss of heat from buildings having the same contents, but of different forms, is shown in the diagrams A B C and D of Fig. 26 A, each of approximately 125,000 cubic feet. Let each have glass equal to one-sixth the exposure, the equivalent glass surface of walls to equal the area of wall surface divided by 4, and let 1 square foot of roof be considered equivalent to one-tenth square foot of glass; the equivalent glass surface of each building is as stated under the different figures. Since the cubic contents is the same, the loss of heat would be roughly proportional to the equivalent glass surface in each. Long, low buildings require less horse-power per 1000 cubic feet than those more nearly cubical in form.

Building D, which is high in proportion to its floor area, would take considerably more horse-power per 1000 cubic feet than those represented by A, B or C.

The loss of heat by leakage of air would be greater in high buildings like D than in low ones like B and C, as they have a greater flue action involving greater leakage and have more wall surface in proportion to their contents than those shown in A, B and C.

CHAPTER VIII.

HEATING WATER.

The question frequently comes up how to determine the heating surface required to heat a given volume of water a certain number of degrees in hot water storage tanks or generators, as shown in Fig. 27. The proportions of feed water heaters in connection with boilers give a basis for such calculations, these heaters of the closed tubular type having 1-3 to $\frac{1}{2}$ square foot of heating surface per boiler horse-power.

HEATING WATER BY SUBMERGED STEAM PIPES.

Taking the greater amount as a basis, $\frac{1}{2}$ square foot of heating surface is expected to heat about 30 pounds of water per hour from, say, 50 to 200 degrees, that is $30 \times 150 = 4500$ heat units. In other words, a square foot is rated to transmit 9000 heat units per hour.

Suppose the exhaust steam pressure is 2 pounds, corresponding to a temperature of about 220 degrees, the average water temperature is $(200 + 50) \div 2 = 125$ degrees, making the average difference in temperature between the steam and the water $220 - 125 = 95$ degrees. Hence the number of heat units transmitted per square foot of heating surface per hour per degree difference in temperature is $9000 \div 95$, or about 100 heat units in round numbers.

Low pressure steam coils surrounded by air at 70 degrees give off only about 2 heat units per degree difference in temperature per hour, whereas when immersed in water they condense steam per degree difference about 50 times as rapidly—a striking fact.

To take a practical example, suppose it is desired to compute the heating surface in brass pipe required to raise the temperature of the water in a 4000-gallon tank from 70 degrees to 160 degrees in two and one-half hours with steam at 5 pounds pressure. The given number of gallons is equivalent to 4000×8.33 (number of pounds per gallon) = 33,333 pounds. The increase

in temperature is 90 degrees. Total number of heat units required is therefore $33,333 \times 90 = 2,999,970$. The number of heat units required per hour is thus approximately 1,200,000. The average difference in temperature between the steam and water is $228 - 115 = 113$ degrees. Since 1 square foot of heating surface with 1 degree difference between the temperature of the steam and water gives off approximately 100 heat units per hour, with 113 degrees difference approximately 11,300 heat units will be given off in an hour, and $1,200,000 \div 11,300 = 106$ square

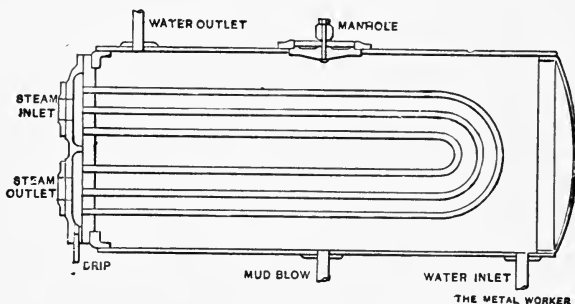

Fig. 27.—Hot Water Storage Tank Heated by Steam.

feet, the area of the heating surface required, which is 1 square foot to approximately 37 gallons capacity.

HOT WATER GENERATORS.

Hot water generators, so-called, otherwise known as coil boilers or hot water storage tanks, commonly have about 1 linear foot of 1-inch pipe to each 5 gallons capacity—that is, about 1 square foot of heating surface to each 15 gallons capacity. Such boilers are commonly assumed to be capable of heating their contents at least once an hour from, say, 60 to 160 degrees.

To heat 300 gallons per hour, for example, 100 degrees would require the expenditure of $300 \times 8.3 \times 100 = 250,000$ heat units (8.3 representing the approximate weight of 1 gallon of water in pounds). With a coil based on the proportions stated, 1 square foot to 15 gallons capacity, the heating surface is 20 square feet and the heat emitted per square foot per hour would be $250,000 \div 20 = 12,500$ heat units.

With steam at 228 degrees and average water temperature at

110 degrees the difference is 118 degrees; the transmission per square foot per hour per degree difference is $12,500 \div 118 = 106$ heat units.

A hot water generator of even moderate size when heating the contents once an hour condenses an immense amount of steam. Take, for example, one of, say, 300 gallons capacity. To heat this volume from, say, 50 to 160 degrees requires $300 \times 81.3 \times 110 = 275,000$ heat units. The condensation of 1 pound of steam at 5 pounds pressure gives off 954.6 heat units; therefore nearly 300 pounds of steam would have to be condensed in an hour, equivalent to about 10 boiler horse-power, or the consumption of 35 to 40 pounds of coal.

In office buildings and apartment houses at certain periods the volume of water drawn from the hot water generator is equal to a per hour rate many times in excess of the average per hour requirements throughout the day. The generator, or hot water storage tank, must be made large enough to meet these demands, just as a storage battery is used to carry an electric plant through certain periods of overload. The steam coil in the generator then has several hours in which to make good the sudden large drafts that occur at intervals.

BOILING LIQUIDS IN VATS.

It is a well-known fact that when water is heated in an open vessel to the boiling point, 212 degrees F., its temperature cannot be increased. If more heat is applied it simply causes the water to boil more rapidly. The amount of heat required to evaporate 1 pound of water at a temperature of 212 degrees into steam at the same temperature is, neglecting decimals, 966 heat units. This is known as the latent heat. The same number of heat units are given up by the steam when it is condensed back into water. For example, an ordinary heating coil condensing about 1.3 pound of steam per square foot per hour gives off a little more than 300 heat units, or about one-third of the latent heat in a pound of steam.

In computing the amount of coil necessary to evaporate a given amount of water in a stated time proper allowance must be made for the latent heat necessary to evaporate the water after

sufficient heat has been applied to bring it to the boiling point. Since the heat given off by the coil depends on the difference in temperature between the steam inside and the water outside one should have 20 to 40 pounds steam pressure in order to provide a reasonable excess of temperature in the steam over the water. For boiling thick, heavy liquids considerably more heating surface is necessary than for boiling water, on account of the more sluggish circulation. The difference in the specific heats also enters in.

HEATING SMALL SWIMMING POOLS.

Hot water generators fitted with steam coils, as shown in Fig. 27, are sometimes used to heat small swimming pools, the water being admitted to the latter through concealed pipes placed near the bottom.

When connected with a gravity return system of steam heating no more attention is necessary with regard to maintaining the proper amount of water in the steam boiler than if the steam coil in the hot water generator were a large radiator, since the condensation returns to the boiler, provided the generator is located well above the water line.

To compute the size of coil required with this method of heating take, for example, a pool 12 x 30 feet in plan and 5 feet in average depth. Its contents, 1,800 cubic feet, multiplied by $62\frac{1}{2}$, the number of pounds 1 cubic foot of water weighs, gives about 112,500 pounds to be heated.

Suppose the water to be continuously changing at the rate of one complete change every ten hours, equivalent to 11,250 pounds of water per hour. If the water in the street mains is at, say, 50 degrees, and that in the pool 75 degrees, $11,250 \times 25 = 281,250$ heat units must be supplied per hour.

It has been pointed out that 1 square foot of heating surface in the generator will give out about 12,500 heat units per hour; therefore $281,250 \div 12,500 = 22.5$, or about 22 square feet of coil would be necessary when using steam of, say, 5 pounds pressure. On the customary basis of 1 square foot of heating surface to 15 gallons capacity, 22 square feet of surface would correspond to a 330-gallon boiler, which, from experience, the writer has found gives good service under the conditions stated.

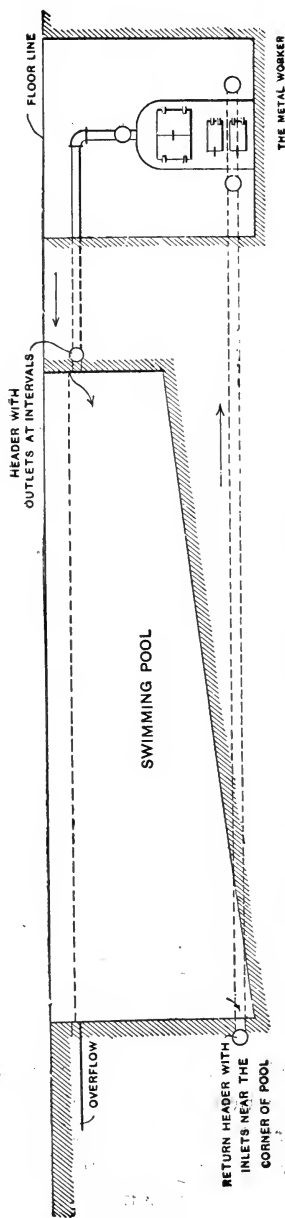

Fig. 28.—Arrangement of Heater Connected with Swimming Pool.

HEATING LARGE SWIMMING POOLS.

For heating large pools one of three methods is commonly used:

1. Steam is admitted directly to the water in the pool through one of the devices on the market for muffling the sound.
2. Steam coils are submerged in the pool.
3. The water is made to circulate through a boiler or heater, as shown in Fig. 28, the pool being practically a huge expansion tank.

AMOUNT OF STEAM AND SIZE BOILER REQUIRED.

The amount of steam that must be admitted to heat the water in a pool will depend on the volume, the temperature and the time in which the heating must be done.

Take, for example, a pool 20 x 80 feet, with an average depth of 7 feet, equal to 11,200 cubic feet, in which the water is to be heated from the street temperature of, say, 50 degrees, to a temperature of 80 degrees during a period of ten hours. Water at the street temperature weighs approximately $62\frac{1}{2}$ pounds per cubic foot; therefore 11,200 cubic feet of water to be raised 30 degrees in ten hours will require a number of heat units per hour equal to

$$11,200 \times 62.5 \times 30 \div 10 = 2,100,000 \text{ heat units.}$$

Suppose the steam be admitted at low pressure, say 5 pounds. One pound at that pressure will supply 955 heat units when condensed, and the water, in cooling from 228 degrees, the temperature of the steam at 5 pounds pressure, to 80 degrees, will give up 148 heat units more, making a total of 1,103 heat units per pound. This figure is contained in the total number of heat units required about 1,903 times—that is, 1,903 pounds of steam must be condensed in one hour.

The boiler capacity required is equal to $2,100,000 \div 33,305$ (which is a boiler horse-power expressed in heat units) = 63 horse-power. The above makes no allowance for the loss of heat by evaporation—a subject previously discussed—nor for losses through the walls or the bottom of the tank.

AMOUNT OF STEAM PIPE REQUIRED.

To ascertain the amount of steam pipe required with steam at, say, 5 pounds pressure, the pipes to be placed around the tank in recesses near the bottom, other conditions to be as stated above, proceed as follows: The average difference in temperature between the steam and water is

$$228 - \left(\frac{50 + 80}{2} \right) = 228 - 65 = 163 \text{ degrees.}$$

The discussion of feed water heaters showed that it is approximately correct to reckon on 100 heat units being given off per hour by the steam to the surrounding water per degree difference in temperature. Hence, with 163 degrees difference, we should expect to transmit to the water 16,300 heat units for each square foot of brass pipe installed. If galvanized wrought iron pipes are used we should expect to get only about 70 per cent. of the heat stated above, or 11,410 heat units per square foot per hour.

The total heat units—viz., 2,100,000—divided by 11,410, gives 184 square feet, or about 368 linear feet, of 1½-inch pipe that would be required to meet the conditions stated. If the water were to be heated in a shorter time proportionately more surface would be required.

The above computations have as a basis the heat given off by the pipes or tubes in feed water heaters where the circulation of water is comparatively rapid. With coils submerged in tanks the movement of water over them is sluggish and the heat is taken up from the pipes less rapidly, hence it is wise to add 25 to 50 per cent. to the computed amount of pipe according to its location to allow for this sluggish circulation.

SIZE BOILER REQUIRED.

If a boiler is to be used, as in the third method mentioned, the amount of coal to be burned, the size of the grate and the size of the boiler may be determined as follows:

The total number of heat units required per hour, as computed above, is 2,100,000. Assuming that 1 pound of coal will give up in this case 9,000 heat units, since the boiler will be more efficient than usual, due to the cooler heating surfaces, the coal required will be $2,100,000 \div 9,000 = 233$ pounds per hour. With a regu-

lar attendant at least an 8-pound rate of combustion per square foot of grate surface per hour may be safely assumed. The grate surface therefore should be $233 \div 8 =$ approximately 30 square feet.

The water in the boiler being only 80 odd degrees instead of, say, 228 degrees, with 5 pounds pressure, less heating surface is required, in proportion to the grate area than with ordinary heating boilers to give the same efficiency. Assuming, as a rough approximation, that the average temperature of the gases in the boiler or heater is 700 degrees, the effectiveness of the heating surface in the two cases would be in the proportion of $\frac{700 - 80}{700 - 228} = \frac{620}{472}$; that is, only about $472 \div 620 = 76$ per cent. as much heating surface per square foot of grate would be required in the boiler used for heating water to 80 or 90 degrees as would be needed in ordinary low pressure boilers.

The gist of this is that a heater for the purpose stated could have an abnormally large grate in proportion to its size and still be economical in the use of coal.

TANK HEATERS.

Tank heaters are commonly rated by manufacturers to heat one-half to three-fourths as many gallons of water per hour as the number of square feet of direct radiating surface they will supply; that is, a heater with a grate 20 x 24 inches connected as shown in Fig. 29, would be rated to carry, say, 600 square feet of radiating surface, or to heat 300 to 450 gallons of water per hour. Manufacturers fail to give the temperatures from and to which the water is heated, but for apartment houses and the like the tank temperature should be kept as a rule at about 160 degrees. Therefore the water must be heated on an average at least 100 degrees above that of the city supply.

It is a simple matter to show on a heat unit basis that a much greater expenditure of heat is necessary to raise 300 gallons—that is, 2,500 pounds—of water 100 degrees than to supply 600 square feet of radiating surface, the heat losses being 250,000 and 90,000 respectively. Therefore tank heaters are commonly overrated. This fact, however, seldom becomes apparent, as the

large capacity of the storage tank enables the heater to heat the water at night, or when little water is drawn, so that time and storage capacity help out the overrated heater.

If one knows approximately the number of gallons of water that must be heated per hour to a given temperature from that of the city supply, the size heater may be readily determined on the heat unit basis. For small heaters, having, say, not over 2 square feet grate surface, the rate of combustion should not exceed 3 pounds per square foot of grate per hour. Larger heaters may

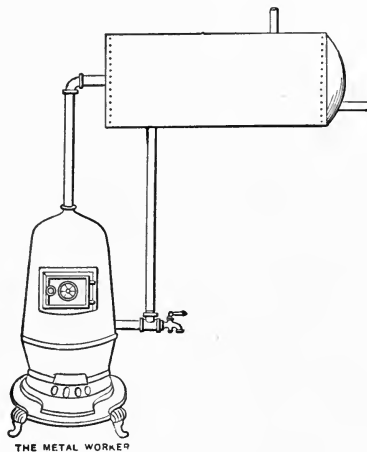

Fig. 29.—Tank Heater Connections.

be rated to burn 4 to 5 pounds or even more with frequent attention.

Example: What size will be required to heat 75 gallons per hour 90 degrees? The product: 75 (gallons) \times 8 1-3 (number of pounds of water in one gallon) \times 90 (the temperature range), gives the number of heat units involved. Dividing this product by 3 (number of pounds of coal burned per square foot of the grate per hour) \times 8000 (the number of heat units utilized per pound of coal) gives 2.3 as the number of square feet of grate surface required. The above basis of computation will be found convenient in determining the size heater to be used for a baptistry pool, when the volume to be heated, the time and the temperature to be attained are known.

By installing a storage tank of good size a small heater may be made to do as good service as a much larger one with a small tank. That is, with a large tank, holding several times the probable maximum hourly volume required, a sudden draft in excess of the ability of the heater to make good immediately is not accompanied by a lowering of temperature at the faucets, as would be the case with a small tank. The assumption is sometimes made that, unless stated to the contrary, heaters rated to supply tanks of certain capacities are capable of heating a volume of water equal to the tank capacity in one hour. As just stated, it is better that the tank capacity should be several times the average hourly consumption.

Taking the ratings of a prominent manufacturer :

- Heater with 12-inch grate is rated to supply a 200-gallon tank.
- Heater with 15-inch grate is rated to supply a 325-gallon tank.
- Heater with 18-inch grate is rated to supply a 485-gallon tank.

Averaging these gives 1 square foot of grate to 266 gallons tank capacity. Even with a rapid rate of combustion, say 5 pounds per square foot per hour, a square foot of grate would heat only about 48 gallons per hour 100 degrees, showing the tank capacity stated in these ratings to be over five times the hourly heating capacity of the heaters.

Suppose the water is heated from a street main at a temperature of 60 degrees to only 120 degrees; then 1 square foot of grate with a 5-pound rate of combustion would heat 80 gallons per hour, or only about one-third the rated tank capacity per square foot stated in the manufacturer's ratings. On the basis of 80 gallons per hour heated from 60 to 120 degrees per square foot of grate, a 320-gallon boiler, contents to be used once an hour, should have a heater with at least 4 square feet of grate surface, equivalent to a grate 27 inches in diameter. This would be uncommonly large for a tank of the size stated, showing that with the ordinary proportions of grate to tank capacity it must not be expected that the contents of the tank will be heated in less than several hours.

WATER BACKS AND GAS HEATERS.

Water backs in ranges ordinarily have 2 to 2½ square inches of heating surface per gallon capacity in the hot water boilers

with which they are connected. The ordinary temperature of water from city mains would be 50 degrees or more, running up to 70 degrees or so in summer. While 160 degrees is a common temperature for the hot water supply in large buildings having a separate heater, the temperature of a domestic supply is generally

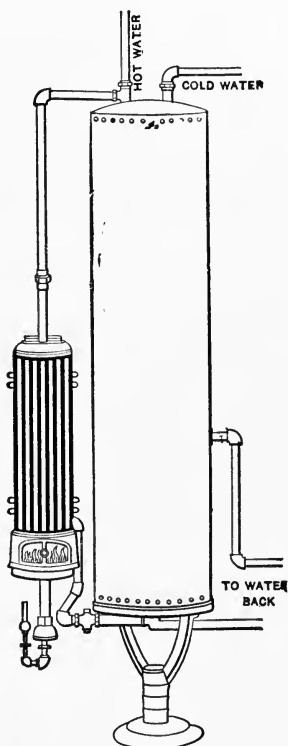

Fig. 30.—Gas Heater Connected with Range Boiler.

much lower, say not over 130 degrees as a rule, though in some cases much higher—even above boiling temperature at atmospheric pressure. Now, under the most favorable conditions the hot water supply must be heated from 70 to 130 degrees, equal to 60 degrees rise.

Take, for example, a 40-gallon boiler connected with a water back of 100 square inches area. To heat 40 gallons per hour 60 degrees would take $40 \times 8.13 \times 60 = 20,000$ heat units, which

with a water back area of about 2-3 square foot would mean over 30,000 heat units per square foot per hour transmitted to the water. Such a rating would be altogether too high with the proportions of water back and tank capacity just stated.

Similar surfaces in furnaces with combination heaters are seldom rated to carry over 75 square feet of direct radiating surface for each square foot of heating surface exposed to the fire; this is equivalent to only 75×150 (150 being the heat units given off per square foot of radiating surface per hour) = 11,250 heat units. This is only a little more than the heat given off per square foot by steam coils in contact with water. The low rating is due to the chilling effect of the coil or water back on the fire in contact with it.

For ordinary working conditions the writer believes a rating of 10,000 heat units per square foot per hour for water backs to be a fair one, but with a brisk fire, as on ironing days, the water back will probably take up as much as 15,000 heat units per square foot per hour.

It is pretty difficult to determine in advance in any household the approximate volume of hot water that must be supplied. Families of the same size differ greatly in the amount of water they are in the habit of using. A water back to meet maximum use would be altogether too large for ordinary use. The best way to meet excessive occasional demands is to use a gas heater, connected as shown in Fig. 30, in addition to the water back.

Tests of ordinary gas heaters used in connection with hot water boilers are stated to have shown efficiencies of 52 to 74 per cent., when burning gas having a heating power of 540 heat units per cubic foot.

COILS FOR HEATING WATER.

Coils for heating the domestic water supply are frequently placed in hot water or steam heaters. On the basis of 15,000 heat units per square foot per hour; to heat 40 gallons per hour, for example, from, say, 60 to 130 degrees, or through 70 degrees, $40 \times 8 \cdot 1-3 \times 70 = 23,310$ heat units would be necessary, requiring about $1\frac{1}{2}$ square feet of heating surface, equal to $4\frac{1}{2}$ lineal feet of 1-inch pipe or 3.5 feet of $1\frac{1}{4}$ -inch pipe.

If the coil is suspended in the combustion chamber above the fire a much lower rating must be assumed. It is well to arrange

the coil so that the fire may be brought in contact with it when desired by carrying a deep bed of coal on the grate. The heating capacity of a coil placed above the fire varies greatly with the condition of the fire on top; a bright fire giving good results and one black on top heating the water but little. As a rule it is a rather unsatisfactory way to heat a water supply unless the fire is run very regularly. A good sized tank should be used to avoid overheating.

An independent hot water stove or tank heater is generally to be preferred. A rating as high as 15,000 heat units should hardly be used, except when the fire is sure to receive careful attention. A rating of 10,000 to 12,000 heat units would represent more closely what could be expected in ordinary practice.

CHAPTER IX.

THE FLOW OF STEAM IN PIPES AND THE CAPACITIES OF PIPES FOR STEAM HEATING SYSTEMS AND FOR STEAM BOILERS.

The following chapter is intended not as an exhaustive discussion of the various methods of proportioning piping systems, nor of the formulas on which the flow of steam is based, but to provide, by tables, a ready means of solving problems relating to pipe sizes. The formulas on which the tables are based make due allowance for the diminished resistance due to an increase in the size of pipes.

The cruder, yet common, method of allowing, for large and small pipes alike, a certain number of thousandths of a square inch in cross sectional area to each square foot of radiating surface makes the larger pipes much greater in area in proportion to the surface supplied than the smaller ones.

A COMPARISON OF FORMULAS.

D'Arcy's modified formula, stated in Kent's "Mechanical Engineer's Pocketbook," gives the weight of steam that will flow per minute through pipes of various sizes as

$$W = c \sqrt{\frac{w(p_1 - p_2) d^5}{L}} \dots\dots\dots(a)$$

where w = the density or weight per cubic foot of steam at pressure p_1 ; $(p_1 - p_2)$ = drop in pressure, or the difference between initial and terminal pressure; d = diameter of pipe in inches; L = length of pipe in feet; c = coefficient, as follows:

Diameter of pipe in inches.	1	2	3	4	5	6	7	8	9
Value of c	45.3	52.7	56.1	57.8	58.4	59.5	60.1	60.7	61.2
Diameter of pipe in inches.	10	11	12	14	16	18	20	22	24
Value of c	61.8	62	62.1	62.3	62.6	62.7	62.9	63.2	63.2

Babcock's formula, given in "Steam," is

$$W = 87 \sqrt{\frac{w(p_1 - p_2) d^5}{L \left(1 + \frac{3.6}{d} \right)}} \dots\dots\dots(b)$$

This may be reduced to a form similar to D'Arcy's formula, but with different coefficients.

Table XVI has been computed from these formulas in order to compare the results for pipes of different sizes. This table is based on the actual inside diameter of standard wrought iron pipes of nominal sizes stated up to 12 inches, inclusive. Sizes of 14 inches and larger are nominal outside diameters of O. D. pipe, the inside diameter of each being $\frac{3}{4}$ -inch less than the outside.

TABLE XVI.

SHOWING THE WEIGHT OF STEAM IN POUNDS THAT WILL FLOW PER MINUTE THROUGH STRAIGHT PIPES 100 FEET IN LENGTH; NO ALLOWANCE BEING MADE FOR RESISTANCE AT THE ENTRANCE TO THE PIPE.

Initial pressure, 5 pounds by gauge, less a drop in pressure in a length of 100 feet, 1 pound.

Formula,	Nominal diameter of pipe in inches.											
	1	1¼	1½	2	2½	3	3½	4	4½	5	6	7
	—Weight of steam, in pounds, flowing through pipe per minute.—											
D'Arcy's	1.14	2.38	3.7	6.7	11.6	20.8	30.3	41.4	56	73	118	174
Babcock's	1.05	2.31	3.6	7.3	11.9	21.9	32.7	46.5	63	86	141	208

Formula,	Nominal diameter of pipe in inches.									
	8	9	10	12	14	16	18	20	22	24
	—Weight of steam, in pounds, flowing through pipe per minute.—									
D'Arcy's	246	327	438	694	910	1,266	1,735	2,285	2,945	3,660
Babcock's	293	394	533	853	1,140	1,590	2,210	2,910	3,760	4,730

APPLICATION OF FACTORS TO TABLE XVI.

Both formulas show the weight of steam delivered to be proportional: (1) To the square root of the density or the square root of the weight per cubic foot; (2) to the square root of the drop in pressure; (3) to the square root of the fifth power of the diameter of the pipe, and (4) to be inversely proportional to the square root of the length of the pipe.

For any other pressure than 5 pounds, on which Table XVI is based, multiply the figures there stated by the square root of the density at the given pressure, divided by the square root of the density at 5 pounds pressure. This gives the following factors for different pressures:

TABLE XVII.

FACTORS TO BE APPLIED TO TABLE XVI FOR OTHER GAUGE PRESSURES THAN 5 POUNDS.

Gauge pressure in pounds.....	1	2	5	10	15	20	30	40
Multiplier	0.90	0.93	1.00	1.11	1.21	1.31	1.47	1.61
Gauge pressure in pounds.....	50	60	70	80	90	100	110	120
Multiplier	1.74	1.86	1.97	2.07	2.18	2.26	2.37	2.46

This table shows, for example, that with 50 pounds pressure 1.74 times as much steam by weight will flow through a given pipe as with 5 pounds pressure; the drop in pressure being the same in each case.

For a drop in pressure other than 1 pound, on which Table XVI is based, multiply the figures in that table by the square root of the given drop corresponding to these factors.

TABLE XVIII.

FACTORS APPLYING TO TABLE XVI FOR OTHER DROPS IN PRESSURE THAN 1 POUND.

Drop in pressure in pounds ($p_1 - p_2$)	$\frac{1}{8}$	$\frac{1}{4}$	$\frac{1}{2}$	$\frac{3}{4}$	1	2	3
Multiplier	0.354	0.500	0.709	0.865	1.00	1.41	1.73

TABLE XIX.

FACTORS FOR OTHER LENGTHS THAN 100 FEET. TOTAL DROP IN PRESSURE ASSUMED TO BE 1 POUND, WHATEVER THE LENGTH OF THE PIPE THE CAPACITY OF WHICH IS BEING COMPUTED. FACTORS OR MULTIPLIERS TO BE USED IN CONNECTION WITH TABLE XVI.

Length of pipe in feet	50	100	150	200	250	300	350	400	450
Multiplier	1.41	1.00	0.816	0.710	0.632	0.578	0.535	0.500	0.471
Length of pipe in feet	500	550	600	650	700	750	800	850	
Multiplier	0.447	0.427	0.407	0.392	0.379	0.365	0.353	0.343	
Length of pipe in feet	900	950	1,000	1,200	1,400	1,600	1,800	2,000	
Multiplier	0.333	0.325	0.316	0.288	0.268	0.250	0.236	0.224	

To illustrate the use of Tables XVI, XVII, XVIII and XIX, suppose it is desired to compute the flow of steam at 50 pounds gauge pressure through a 3-inch pipe 400 feet long, the drop in pressure to be 2 pounds. Table XVI gives, with D'Arcy's formula, 20.8 pounds as the weight of steam passing in one minute through a pipe 100 feet long, with 1 pound drop in pressure. Applying the factors in Tables XVII, XIX and XVIII, respectively, corresponding to the above conditions, we have $20.8 \times 1.74 \times 0.5 \times 1.41 = 25.43$ pounds as the weight of steam flowing through the pipe per minute.

RESISTANCES TO THE FLOW OF STEAM.

In computing the flow of steam from Table XVI, the resistance at the entrance to the pipe at elbows and globe valves should be allowed for by adding to the actual length of the pipe a length that would produce the same resistance to the flow as that at these

points. The resistance at the entrance is commonly expressed in connection with Babcock's formula by the equation

$$R = \frac{114 \text{ diameters}}{1 + (3.6 \div d)} \dots \text{ "c."}$$

where R equals a length of straight pipe expressed in diameters that would interpose the same resistance as that at the entrance and d equals diameter of pipe in inches.

Very little has been published giving the results of tests bearing on this subject. Treatises on hydraulics, in discussing the flow of water in pipes, which follows the same general laws as the flow of steam, give tables and data showing the length of pipe equivalent in resistance to that at entrance to be approximately one-third of that given by formula "c." The use of formula "c" in computing pipe sizes for steam heating systems gives sizes much in excess of those found necessary in practice. The author, therefore, favors the use of

$$R = \frac{1}{3} \times \frac{114 \text{ diameters}}{1 + (3.6 \div d)} \dots \text{ "d."}$$

The values corresponding to the latter formula, reduced to feet, are as follows:

TABLE XX.

THE RESISTANCE AT THE ENTRANCE OF PIPES EXPRESSED IN THE NUMBER OF FEET OF STRAIGHT PIPE THAT WOULD PRODUCE THE SAME RESISTANCE AS THAT AT THE ENTRANCE.

*Nominal diameter of pipes in inches.	Resistance based on Formula "d."—Feet.	*Nominal diameter of pipes in inches.	Resistance based on Formula "d."—Feet.
1.....	0.8	7.....	14.7
1¼.....	1.2	8.....	17.5
1½.....	1.6	9.....	20.4
2.....	2.4	10.....	23.4
2½.....	3.1	12.....	29.4
3.....	4.5	14.....	35.3
3½.....	5.1	16.....	41.3
4.....	6.7	18.....	47.3
4½.....	7.9	20.....	53.6
5.....	9.3	22.....	60.0
6.....	12.1	24.....	66.0

* Nominal diameter of 14-inch pipes and larger is the outside diameter.

The resistance at a globe valve of given size is commonly allowed for by adding to the actual length of pipe a length three times that stated in Table XX, and for a standard elbow a length twice that stated in the table. These values are, however, to be

considered as only approximately true, although they are near enough for practical use. The longer the pipe the less will be the error in the computed flow due to any uncertainty or error in the allowance made for the three resistances at entrance, elbows and globe valves.

The use of long turn elbows and straightway gate valves practically eliminates two of these resistance losses, and the other is considerably reduced by reaming the pipes at the ends, as is common in hot water work.

The following example will illustrate the use of Table XVI, the multipliers in Tables XVII, XVIII, and XIX, and allowance in Table XX:

How many pounds of steam will flow per minute through a 4½-inch pipe 800 feet long, with four elbows and one globe valve? Initial gauge pressure, 10 pounds. Drop in pressure, 2 pounds.

	Feet.
Actual length of pipe.....	800
Allowance for loss at entrance (Table XX approximately).....	8
Allowance for two elbows.....	32
Allowance for one globe valve.....	24
Total equivalent length of straight pipe, making due allowances as above.	864

A length of 850 feet is the one most nearly corresponding to this length in Table XIX. The factor for this length is 0.343; for 10 pounds pressure the factor in Table XVII is 1.11; for 2 pounds drop in pressure the factor in Table XVIII is 1.41. The flow of steam in pounds by D'Arcy's formula, stated in Table XVI, to which these factors apply, is for a 4½-inch pipe 56 pounds. For a length of 800 feet, with conditions as stated, the computed flow would be $56 \times 0.343 \times 1.11 \times 1.41 = 30.1$ pounds per minute.

EFFECT OF CONDENSATION.

No account has been taken in the foregoing of the effect of condensation on the flow of steam. It is assumed that pipes will be covered, which will reduce this effect to about one-third of what it would be if they were bare. The condensation, while it cuts down the volume of steam, at the same time causes a greater drop in pressure. This, in turn, increases the velocity, tending to

offset the loss by condensation. A further discussion of this subject may be found in Kent's "Mechanical Engineers' Pocket Book."

STEAM FLOW WITH MORE THAN 40 PER CENT. DROP IN PRESSURE.

It is to be borne in mind, in making computations of the flow of steam, that steam of 25 pounds gauge pressure or more, discharged from a pipe against atmospheric pressure or against a pressure less than three-fifths the initial pressure, has a nearly constant velocity of 900 feet per second, in round numbers, the weight discharged increasing with the pressure and being proportional to the density or weight per cubic foot. The approximate weight of steam that will flow per hour through a pipe under the conditions just stated is equal to $50 \times$ (absolute pressure of steam) \times (area of pipe in square inches).

This constant velocity applies only to very short pipes.

RELATIVE CAPACITIES OF PIPES.

The relative capacities of pipes under the same conditions are shown in Table XVI, D'Arcy's values being the safer to use. This table will be found convenient in determining the size of pipe necessary to supply a number of smaller ones.

Example: What size pipe is required to supply one 2½, two 3 and one 4 inch pipes?

The capacities in Table XVI are, in the order stated, 1 x 11.6, 2 x 20.8, 1 x 41.4; total, 94.6. A 6-inch pipe with a capacity of 118 should be used, since a 5-inch pipe has a capacity of only 73.

It will be noted that the capacity of pipes increases much more rapidly than their area—*e. g.*, the relative capacities of 8 and 4 inch pipes in Table XVI are 246 and 41.4, or in the ratio of 6 to 1, whereas their areas are in the ratio of about 4 to 1.

Table XXI, which has been computed from Table XVI, gives the proper size of mains to supply branches of the sizes stated in the upper and side lines.

The Flow of Steam in Pipes.

TABLE XXI.

ELEVATION OF PIPES.

Size branch..1	Size mains to supply branches of sizes stated in upper and side lines.												Size branch		
1 1/4	1 1/2	2	2 1/2	3	3 1/2	4	4 1/2	5	6	7	8	9	10	12	1
1 1/2	2	2 1/2	3	3 1/2	4	4 1/2	5	6	7	8	9	10	12	12	1 1/4
2	2 1/2	3	3 1/2	4	4 1/2	5	6	7	8	9	10	12	12	12	1 1/2
2 1/2	3	3 1/2	4	4 1/2	5	6	7	8	9	10	12	12	12	12	2
3	3 1/2	4	4 1/2	5	6	7	8	9	10	12	12	12	12	12	2 1/2
3 1/2	4	4 1/2	5	6	7	8	9	10	12	12	12	12	12	12	3
4	4 1/2	5	6	7	8	9	10	12	12	12	12	12	12	12	3 1/2
5	6	7	8	9	10	12	12	12	12	12	12	12	12	12	4
6	7	8	9	10	12	12	12	12	12	12	12	12	12	12	5
7	8	9	10	12	12	12	12	12	12	12	12	12	12	12	6
8	9	10	12	12	12	12	12	12	12	12	12	12	12	12	7
9	10	12	12	12	12	12	12	12	12	12	12	12	12	12	8
10	12	12	12	12	12	12	12	12	12	12	12	12	12	12	9
12	12	12	12	12	12	12	12	12	12	12	12	12	12	12	10
16	12	12	12	12	12	12	12	12	12	12	12	12	12	12	12

NOTE.—Minus signs (—) indicate that mains of the sizes stated are of ample size to supply the branches stated opposite them. Plus signs (+) indicate that mains of the sizes stated are a trifle smaller than given by the formula, but not sufficiently so to warrant increasing the main to the next size, except when the requirements are unusually exacting as to the permissible drop in pressure.

SIZES OF STEAM HEATING MAINS.

For steam heating work it is generally more convenient to deal with heat units and the amount of direct radiating surface that pipes of different sizes will supply, than with the weight of steam they will carry. A conservative basis is to allow 250 heat units per hour per square foot of ordinary cast iron direct radiating surface, with steam at low pressure, say 3-5 pounds.

A pound of steam at 5 pounds pressure has a latent heat of 954.6 units—that is, it will give up 954.6 heat units when condensed to water at the steam temperature in the radiator.

Table XXII has been deduced from the flow of steam computed from D'Arcy's formula, as stated in Table XVI, on the basis of 250 heat units per square foot of radiation and 954.6 heat units given off per pound of steam, which is equivalent to 0.262 pounds of steam condensed per hour per square foot of direct radiating surface.

TABLE XXII.

THE AMOUNT OF ORDINARY CAST IRON RADIATING SURFACE THAT MAY BE SUPPLIED BY PIPES OF DIFFERENT SIZES, 100 FEET LONG, WITH 5 POUNDS INITIAL GAUGE PRESSURE AND THE DROP IN PRESSURE STATED IN THE COLUMN AT THE LEFT. FOR OTHER PRESSURES AND FOR LENGTHS IN EXCESS OF 100 FEET, USE FACTORS IN TABLES XVII AND XIX. RESISTANCE AT ENTRANCE, ELBOWS AND GLOBE VALVES MAY BE ALLOWED FOR AS STATED IN TABLE XX BUT THIS IS GENERALLY UNNECESSARY FOR ORDINARY WORK, A SLIGHT EXCESS IN THE DROP IN PRESSURE OVER THAT ASSUMED COMPENSATING FOR THE RETARDING EFFECT OF THE ENTRANCE, ELBOWS AND VALVES.

Line.	Diameter of pipes, Inches.....		Drop in pressure.							
	1	1¼	1½	2	2½	3	3½	4	4½	
	Pounds.	Square feet of radiating surface.								
A.....	1	261	545	847	1,535	2,660	4,770	6,950	9,500	12,820
B.....	¾	226	472	732	1,325	2,300	4,120	6,000	8,210	11,100
C.....	½	185	386	600	1,087	1,881	3,370	4,930	6,730	9,100
D.....	¼	130	273	423	767	1,330	2,385	3,475	4,750	6,210
E.....	⅓	92	193	299	543	940	1,680	2,460	3,360	4,530
F.....	1/16	65	136	212	384	665	1,192	1,740	2,380	3,210
G.....	1/32	46	96	150	272	470	845	1,230	1,680	2,270

Diameter of pipes, inches.....		5	6	7	8	9	10	12
Drop in pressure. Pounds.		Square feet of radiating surface.						
Line.		1	1/4	1/2	3/4	1	1 1/4	1 1/2
A.....	1	16,710	27,000	39,800	56,300	75,000	100,000	159,000
B.....	3/4	14,450	23,350	34,400	48,750	64,800	86,500	137,500
C.....	1/2	11,810	19,100	28,200	39,800	53,000	70,800	112,500
D.....	1/4	8,355	13,500	19,900	28,150	37,400	50,000	74,500
E.....	1/8	5,900	9,530	14,060	19,900	26,400	35,400	56,200
F.....	1/16	4,180	6,750	9,950	14,100	18,700	25,000	39,800
G.....	1/32	2,960	4,780	7,050	10,000	13,300	17,700	28,200
Diameter of pipe, inches.....		14	16	18	20	22	24	
Drop in pressure. Pounds.		Square feet of radiating surface.						
Line.		1	1/4	1/2	3/4	1	1 1/4	1 1/2
A.....	1	214,000	290,000	398,000	524,000	675,000	845,000	
B.....	3/4	186,000	250,000	343,000	453,000	583,000	730,000	
C.....	1/2	151,000	206,000	282,000	371,000	478,000	598,000	
D.....	1/4	107,000	145,000	198,000	262,000	338,000	425,000	
E.....	1/8	75,100	102,500	140,000	185,000	238,000	298,000	
F.....	1/16	53,300	72,600	99,000	131,000	169,000	212,000	
G.....	1/32	37,900	51,300	70,500	93,000	

NOTE.—Sizes 14 inches and larger are outside diameters. For sizes of returns see note under Table XXIV.

Table XXII shows a marked difference in the amount of radiating surface that may be applied with different assumed drops in pressure.

Mains may be proportioned as follows:

For systems trapped to an open receiver with the heating surface located well above same, a drop of 1/4 to 1/2 pound may be allowed.

For gravity return systems, where the radiators are located some distance, say 5 feet or more, above the water line in the boiler, 1-16 to 1/8 pound drop may be assumed in proportioning the piping. Where the radiators are but little above the water line, as in indirect systems, use 1-32 pound drop.

When exhaust steam is used and it is desired that the minimum back pressure be carried on the system, an assumed drop of 1-32 to 1-16 pound may be used, preferably 1-32 pound drop.

The size of vertical pipes or overhead feed risers of single pipe systems may be based on line G, Table XXII. This will give sizes corresponding to those based on 2 pounds pressure with a little greater drop than 1-32 pound, and will be found ample for exhaust steam heating.

In high buildings, with the single pipe overhead feed system, the risers must be very liberally proportioned on the lower stories, since they must carry not only steam to the radiators below, but the condensation from the radiators above.

It should be noted that pipe sizes based on the recommendations just made will be large enough to supply steam at, say, 2 or 3 pounds pressure to the radiating surface stated, but with a slightly greater drop in pressure.

Pipe sizes given in Table XXII to supply a given radiating surface with steam at 5 pounds pressure will be very nearly correct

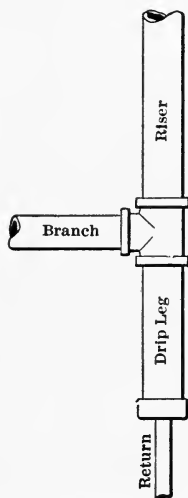
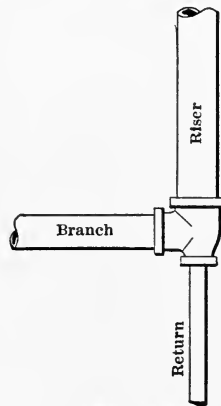

Fig. 31.



THE METAL WORKER

Fig. 32.

for higher pressures within the ordinary limits of steam heating, say up to 15 pounds. This is true, since the total heat supplied by the steam at higher pressures, taking into account its increased weight and decreased latent heat just about keeps pace with the increased radiation of heat.

SIZES OF RISERS—ONE-PIPE SYSTEM.

The risers of one-pipe up feed steam heating systems must be made large enough to supply the radiators and also permit the condensation to return by the same route. It is, therefore, well to limit the velocity to, say, 15 feet per second. On this basis.

with steam of 2 pounds pressure, pipes will supply ordinary cast iron direct radiators as follows :

TABLE XXIII.

CAPACITY OF UP FEED RISERS, ONE-PIPE SYSTEM.

Size of riser, one-pipe system.—Velocity steam, 15 feet per second.	Approximate radiating surface supplied.—Steam, 2 pounds pressure.	Size of riser, one-pipe system.—Velocity steam, 15 feet per second.	Approximate radiating surface supplied.—Steam, 2 pounds pressure.
Inches.	Feet.	Inches.	Feet.
1	*50	2½	300
1¼	*90	3	460
1½	130	3½	620
2	210	4	800

* It is advisable to make the upper end of riser the full size of standard radiator connections—viz., 1 inch up to 24 feet and 1¼ inches for 25 to 60 feet.

Down feed risers may be safely rated to carry at least 25 per cent. more surface than stated in the table. Care should be taken to proportion the risers liberally near the lower end to provide for the removal of condensation.

Branch connections with radiators should be the same size as regular tapping, except when radiators are located more than 4 or 5 feet from risers. In this event the connections should be increased one size to lessen the velocity and permit the condensation to easily flow back against the current of steam.

It is better to drip the riser as indicated in Fig. 31 than as shown in Fig. 32. With the latter the condensation is apt to be swept up along the heel of the elbow, causing a click, or water hammer. The arrangement shown in Fig. 1 forms a separator and the condensation trickles away quietly through the relief or return pipe.

SIZES OF RISERS—TWO-PIPE SYSTEM.

With the two-pipe up feed system risers may be considerably smaller for a given radiating surface than in the one-pipe system, since the condensation from the radiators is conducted away through separate returns.

Table XXIV gives safe allowances :

TABLE XXIV.

CAPACITIES OF UP FEED RISERS, TWO-PIPE SYSTEM.

Size of riser for two-pipe, up feed steam heating.	Approximate radiating surface supplied.—Steam at 2 pounds pressure.	Size of riser for two-pipe up feed steam heating.	Approximate radiating surface supplied.—Steam at 2 pounds pressure.
Inches.	Feet.	Inches.	Feet.
1	*70	2½	570
1¼	*130	3	1,020
1½	*190	3½	1,490
2	330	4	2,000

* It is advisable, at the upper ends of long risers, to make the riser the full size of standard radiator connections—viz., 1 inch up to 48 feet; 1¼ inches for 49 to 96 feet, and 1½ inches for 97 and up to 190 feet.

For down feed risers it is safe to allow 25 per cent. more surface than stated in the above table.

In high buildings, say over five or six stories, allow 10 per cent. less surface than that stated to allow for the increased length of and condensation in risers. Returns are commonly made one size smaller than the supply up to 2½ inches; above that the returns may be two sizes smaller, and for larger pipes, where the return has ample fall, it may be made one-half the diameter of the supply pipe, or even smaller.

PIPE SIZES FOR THE TWO-PIPE VACUUM SYSTEM OF STEAM HEATING.

Supply connections with radiators and coils in the two-pipe vacuum system of steam heating are commonly ¾ inch up to 50 square feet, 1 inch for 51 to 100 square feet, 1¼ inches for 101 to 190 square feet, 1½ inches for 191 to 310 square feet, 2 inches for 311 to 670 square feet, 2½ inches for 671 to 1250 square feet and 3 inches for 1251 to 2040 square feet. It will be noted that these are considerably smaller than pipe connections with ordinary low pressure heating systems.

Sizes of up feed risers in buildings of six or eight stories may be based on Table XXII, line D. In proportioning risers in high office buildings with the down feed vacuum system Table XXII, line E, may be used. The lower portion of such risers should be proportioned to supply 10 to 15 per cent. less surface than that stated in the table, since they must not only supply steam to the radiators, but must carry away the condensation from the attic mains and

from the risers above. Return risers are very much smaller than with the ordinary two-pipe system.

The following table gives safe allowances for horizontal returns. These allowances may be safely increased 20 to 30 per cent. for short lines.

TABLE XXV.

RETURN PIPE CAPACITIES FOR TWO-PIPE VACUUM SYSTEMS.

Size of return pipe.	Square feet of direct radiating surface to which return pipe is adapted.
$\frac{3}{4}$ inch.....	200
1 inch.....	200- 800
$1\frac{1}{4}$ inches.....	800- 1,500
$1\frac{1}{2}$ inches.....	1,500- 3,000
2 inches.....	3,000- 6,000
$2\frac{1}{2}$ inches.....	6,000-12,000
3 inches.....	12,000-20,000
$3\frac{1}{2}$ inches.....	20,000-30,000
4 inches.....	30,000-40,000

Return risers may be rated as follows :

$\frac{3}{4}$ inch up to.....	1,000 feet.
1 inch up to.....	1,600 feet.
$1\frac{1}{4}$ inches up to.....	2,500 feet.

The size of main steam supply pipes and branches should be based on the distance of the most remote radiator from the source of supply, the distance in overhead feed systems to be measured from the center of distribution in the attic. It is not necessary to add the length of the main exhaust pipe from the basement, since it is merely a reservoir of steam, and distribution really begins at the tee connected with the same in the attic.

For lengths of 100 feet or less pipe sizes based on line C of Table XXII agree fairly closely with common practice in this class of work. For other lengths, multiply the figures in line C by the factors in Table XIX in order to ascertain the capacity of pipes, expressed in the square feet of radiating surface, they will supply.

Smaller pipes, both for supply and return, could be made to do the work by carrying a few ounces more pressure on the mains or by causing the pumps to maintain a stronger pull on the returns.

COMPARISON OF DIFFERENT METHODS OF DETERMINING THE SIZE OF STEAM MAINS TO SUPPLY RADIATING SURFACES.

In addition to the foregoing it seems wise to reprint here an article by Earnest T. Child that appeared under the above heading in *The Metal Worker* of Aug. 19, 1899.

The primary method of figuring the sizes required is to ascertain the volume of steam which will be condensed by the radiating surface. This being known, the size of pipe may be computed by assuming a velocity of flow, which will cause a loss of pressure not exceeding 12 inches water head per 100 feet of pipe; say, a velocity of 50 feet per second, which will give an approximate frictional resistance of 8 inches of water per 100 feet.

For instance, to supply 1000 square feet of radiating surface at 5 pounds gauge pressure:

Temperature of steam = 227 degrees F.

Temperature of air in room, 70 degrees F.

Difference, air and steam, 157 degrees F.

British thermal units radiated per square foot of surface as per experiments by Wm. J. Baldwin, J. H. Mills, and others average 275. This gives 275,000 British thermal units per hour. As each pound of steam at this pressure is capable of yielding 954 British thermal units, it will require 288 pounds of steam per hour. One cubic foot of steam at 5 pounds weighs 0.0511 pounds, so 288 pounds equal 5636 cubic feet per hour, or 1.56 cubic feet per second, which, flowing at the rate of 50 feet per second, will require an area of 0.0312 square foot, or 4.59 square inches. This would require a pipe 2.4 inches in diameter, and as the next higher commercial size is 2½ inches in diameter, this would be the size required.

This is a roundabout way, however, and various formulas have been evolved for figuring the pipe sizes.

Robert Briggs in his "Steam Heating" uses a formula which has been extensively followed either directly or in a modified form, in which d = diameter of pipe; q = 9.2 cubic feet of steam

per 100 square feet radiating surface; l = length of main in feet; and h = head of steam to produce the flow. From this

$$d = 0.5374 \sqrt[5]{\frac{Q^2 l}{h}}$$

Frederic Tudor uses a modified form of the same, in which C = volume of steam per minute = $9.2 \times$ total radiating surface $\div 100$; L = length of main in yards; and H = head in inches of water lost [loss in] pressure; d = diameter of pipe. From which

$$d = \sqrt[5]{\frac{C^2 \times h}{H}} + 3.7$$

These two formulas, when figured on a basis of 6 inches lost [loss in] pressure in a 100-foot run, agree very closely.

A rule given by Wm. J. Baldwin in his "Steam Heating for Buildings," and also published by Geo. H. Babcock, states that diameter of main in inches should equal one-tenth of the square root of the total radiating surface, mains included. This rule, when compared with the two previous ones, provides for a much more ample pipe, and on systems of over 4000 square feet it would be safe to use on mains as long as 600 feet, though it does not primarily take in the element of distance at all. Even for smaller systems it gives a relatively large diameter, and for 10,000 square feet of surface it gives a diameter fully 35 per cent. larger than the best accepted practice, which means an area which is nearly doubled.

A. R. Wolff, in his "Addendum to Steam Heating" by Briggs, gives the following: "For determining the cross section area of pipes (in square inches) for steam mains and returns, it will be ample to allow a constant of 0.375 square inch in coils and radiators, 0.375 square inch when exhaust steam is used, 0.19 square inch when live steam is used and 0.09 square inch for the return for each 100 square feet of heating surface. If the cross sectional areas thus obtained are each multiplied by one and three-elevenths, and the square root extracted from each product, the respective figures will represent the proper diameters in inches of the several steam pipes referred to. The steam mains should never be less

than $1\frac{1}{2}$ inches in diameter, nor the returns less than $\frac{3}{4}$ inch in diameter."

This rule does not take into account the relative decrease in friction in pipes of larger diameters, and while in systems under 2500 square feet it follows the Briggs and Tudor formulas very closely, on larger areas it goes up more rapidly on account of the fact that the area of the main is directly proportional to the area of the radiating surface. This formula is safe to use for mains under 200 feet in length, but if this be exceeded the area should be proportionally increased.

Prof. R. C. Carpenter, in his "Treatise on Heating and Ventilating Buildings," uses Briggs' formula, with the exception that for a frictional resistance of 6 inches water column he uses the value of 318.6 for H instead of 477.8, which gives a 50 per cent. larger area of main; but as this table is figured for a single pipe system, 50 per cent. larger areas will, of course, be necessary. In figuring for a separate return he uses the Briggs formula without change. His rule for bends and obstructions is as follows: "Right angle ells add 40 diameters; globe valve, 60 diameters; entrance tee, 60 diameters. For other resistances and steam pressures multiply the diameters by the following factors:

Water level above boiler.....	2 inches.	12 inches.	18 inches.
Multiply by.....	1.25	0.88	0.80
Steam pressure above atmosphere.....	0 pound.	3 pounds.	30 pounds.
Multiply by.....	1.03	1.02	0.97

For indirect heating with separate return use the result as obtained."

The result of the above formula when plotted gives diameters about $\frac{1}{2}$ inch larger than A. R. Wolff's rule up to 5000 square feet, and at about 7600 square feet the lines across (see chart). On the other hand, when the "double pipe system" line is plotted, it follows the Wolff and Tudor curves quite closely up to 4000 square feet, and at 7000 square feet it drops below them all.

The results of all the above formulas have been plotted on a chart presented herewith, and it will be seen that for practical work as well as handiness in figuring and ease in remembering a simple formula, A. R. Wolff's rule of 0.375 square inch per 100 square feet of surface is best adapted to ordinary conditions of low pressure heating.

A line for sizes of returns has also been plotted, based on 0.1 square inch for each 100 square feet of surface. This gives an area about 11 per cent. larger than that used by Mr. Wolff; but

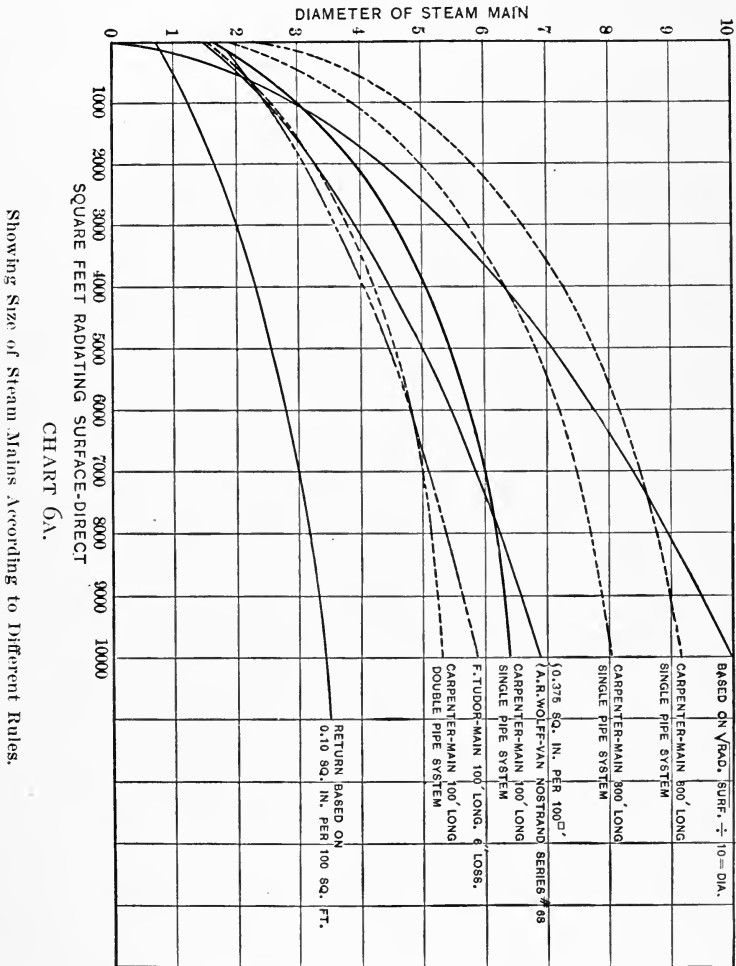

it will be noticed that the results are very nearly in line with the best practice.

Various rules for pipe sizes may be found, all of which vary in a greater or less degree, and seem to have been arrived at in a

more or less roundabout way, or by some rule of thumb. To illustrate the range covered by these rules a comparative table is given herewith, which may prove interesting:

TABLE XXVI.

DIAMETER OF PIPE AND NUMBER OF SQUARE FEET SUPPLIED.

Name.	1-inch.	1¼-inch.	1½-inch.	2-inch.	2½-inch.	3-inch.	3½-inch.
Billings	225	450	700	1,200	1,500
Tudor	40	80	160	320	640	1,280
Nason	125	200	500	1,000	1,500	2,500
Willett	40	70	110	220	360	560	810
Wolff	60	120	200	480	880	1,500

Billings, in his "Ventilating and Heating," states that the only objection to having steam mains large is increased first cost, but this is a poor argument for an engineer to set forth, as it is his business to design a system which will give the best and most economical results at a moderate first cost. He also overlooks the fact that larger pipes cause a greater loss by radiation.

The sizes used by Frederic Tudor are for connections to radiators only, the mains being determined by the formula previously stated. This is a simple rule, and has been proven very satisfactory. He allows 40 square feet radiation for each 1-inch pipe, and doubles the figure for each successive size up to 3 inches.

The sizes given by J. R. Willett are very large indeed compared with other authorities, and are not to be recommended.

The sizes used by the Nason Mfg. Company and A. R. Wolff, as given on pages 540 and 541 of Kent's Handbook, are almost identical. Of these five cases the rule used by Tudor appeals to the writer [E. T. Child] as being the simplest and most practical, in that it is easily applied and not easily forgotten; and while it gives sizes which are ample to fulfill the requirements it does not overdo the matter. Of course single radiators seldom aggregate more than 300 square feet on direct work, and it will be noted that up to this size there is very little variation in the sizes used by all.

The formulas given in the foregoing relate entirely to direct radiation. It has been found that indirect stacks condense from 50 to 100 per cent. more steam than direct, depending upon the velocity of the air passing over them, other conditions being the same. R. C. Carpenter states in his "Heating and Ventilating Buildings":

“The indirect heating surfaces require about twice as much heat as the same quantity of direct radiating surface, and hence, for same resistance in the pipe, the area should be twice that required in direct heating. It will usually be sufficiently accurate to use a pipe the diameter of which is 1.4 times greater than that for direct heating.” But he makes a statement earlier in the book that for indirect heating with separate return an area 50 per cent. larger than that used for direct heating will be sufficient. To cover all contingencies, however, it will be safe to figure an area twice as large as for direct, and the same rule, of course, applies to the return.

Indirect heaters, when used in connection with a fan, condense even more steam than when operated under natural draft, on account of the greater velocity bringing more air into contact with the radiating surface in a given time. The quantity of steam which will be condensed in them under these conditions is, however, a decidedly variable quantity. Suppose, for instance, that the air entering the heater is at 0 degrees F., then the condensation will be 36 per cent. greater than it would if air were returned from the building at 60 degrees F.; velocity being constant and steam pressure 5 pounds gauge. If the velocity of air passing through the heater changes from 750 to 1500 feet per minute there will be a further increase of at least 30 per cent.; making a total variation of about 77 per cent. in the amount of steam condensed. J. H. Mills states that 1000 cubic feet of air passing over each square foot of surface will cause it to condense from 900 to 1300 British thermal units.

LOW PRESSURE HEATING MAINS.

The following extracts from an article by C. E., which appeared in *The Metal Worker* of June 25, 1904, are reprinted here as adding something to the general fund of information on this subject:

“Gradually a set of rules for accurately determining the size of steam mains is being evolved. One of the earliest of these, and one of the most extensively used, states that a square inch of free cross sectional area in a steam pipe will supply 100 square feet of radiating surface. This rule is qualified by its originator in many different ways, so much so that he is reputed to have said that if

a pipe proved too small to double its size. This rule totally neglects the varying amount of frictional resistance between large and small pipes. It is rather absurd, of course, to assume that the carrying capacity of an 8-inch pipe can be computed by the same rule as a 1¼-inch pipe."

There are numerous other rules which have appeared in the more recent scientific books, all of which are helpful in their way, but none of which is in very general use among engineers, owing to the fact that they cannot be applied to pipes of all sizes.

Probably one of the safest rules in calculating the size of a steam heating main is that in common use among engine builders—that is, basing the size of the pipe to give an arbitrary velocity of steam flowing through. In high pressure work the safe velocities are well known; but in low pressure work this is not so, as there are only a few offices in which this method of calculating sizes has been experimentally reduced to a comparatively exact science and in which the safe velocities for various sizes of pipes used for different purposes are definitely known.

The basis, of course, for any such rule must be the amount of steam condensed by a direct radiator of the usual type working under normal conditions with the outside temperature at zero. After an exhaustive series of experiments it has been determined that this will amount to approximately 0.3 pound of steam condensed per hour per square foot of radiating surface. This amount, 0.3 pound, is based on using steam at zero pressure; but, as the ordinary steam heating plant is designed to operate at 1 to 10 pounds pressure, the difference in the amount of condensation at pressures within that range, although considerable, would not be enough to overload liberally designed piping.

Given the square feet of heating surface, the cubic feet of 1 pound of steam and the safe velocity, it is an easy matter to determine the size of the piping. The only difficult part is to determine what is the safe velocity for a given condition. No set of calculations, no matter how elaborate, will give this; nor can one fall back on the experience of the steam fitter, as he hasn't the slightest idea how fast the steam is going.

The best sources of information available indicate that the following velocities are safe. They are based on extensive experi-

ments and observations among old buildings in which the piping is very small: A velocity of 80 feet per second is perfectly safe in mains 2 to 3½ inches, inclusive. On mains of these sizes the frictional resistance is rather high, so that the velocity used is low. Still, even at that, a 3-inch main will supply 1800 square feet of direct radiation. According to the old rule of a square inch of area to 100 square feet of surface, the same pipe would supply only about 750 square feet—rather a wide variation between two rules; yet the former has been demonstrated time and again to be perfectly true.

For 1¼ and 1½-inch mains the safe velocity is hardly more than 50 feet per second; but, as a matter of practice, these sizes are rarely used with any but an arbitrary amount of radiation, depending on local conditions. At 50 feet velocity a 1½-inch pipe will supply 300 square feet of radiation. A velocity of 90 feet is low enough for 4 to 6 inch pipe, inclusive. On this basis a 5-inch main will supply 5700 square feet. This is probably considerably more than current practice among steam fitters allows. On pipes larger than 6 inches a velocity ranging from 95 to 100 feet per second is considered good practice. An 8-inch pipe at 100 feet velocity will carry about 15,000 square feet of direct radiation, and a 12-inch pipe about 35,000 square feet.

It is presumed, of course, in giving the above figures that the pipes are insulated with a fair make of covering and that they are reasonably dripped.

An elaborate system of drips is not essential, but the importance of a reasonable dripping cannot be overestimated. A main cannot be expected to carry its maximum amount of surface if in addition it must carry the condensation from a long system of mains. Furthermore, it is necessary that the drips be made in a way that will avoid any churning of water in the fittings at the drips. There is nothing so fatal to the capacity of a main as the churning and splashing caused by badly made drips and by wrong pitch.

For continuous circuit main work, so largely used nowadays, especially in the smaller class of buildings, it is necessary to provide carrying capacity in the mains for the entire amount of condensation as well as the steam, although it may be urged that as the

amount of water increases the amount of steam decreases. Still it is usual to make large allowance for the water in this class of work, using a velocity of about 60 feet for the smaller size mains and 70 feet for the larger sizes. On this basis a 5-inch continuous circuit main will supply about 4000 square feet of radiation.

The proper proportioning of the risers in a heating plant is probably the most difficult part. It is of course fatal to the entire apparatus to get them too small; and, at the same time, structural conditions usually, and the wishes of the architect or owner, necessitate making them as small as possible. A low velocity must be used on account of the reverse flow of water; much more serious in one-pipe work than in two-pipe. A velocity of 40 feet per second is perfectly safe on one-pipe risers and 50 feet for two-pipe risers. On this basis a 2½-inch one-pipe riser will supply 600 square feet of radiation and 2½-inch two-pipe riser about 750 square feet. These figures may seem excessive, but they are constantly in use and give excellent results. [These are greatly in excess of the capacities given in Tables XXIII and XXIV.]

No set velocities for radiator connections can be given, as these are determined arbitrarily by good practice, it being necessary to make allowance for many other things besides the amount of steam a connection will normally carry. The sizes are well known and will not be repeated here.

It is essential, in designing any steam heating apparatus, to provide for the very heavy demand for steam when the plant is put in operation in the morning. The effect of this, of course, is to increase the velocities, which effect is most troublesome in the risers and radiator connections. The velocities as given above are sufficiently low to provide for this, so that no further allowance need be made. It will be noticed that the risers will be far larger than the mains in proportion to the amount of steam they carry. Radiator connections in good practice are made larger than any possible demand for steam would necessitate.

SIZES OF MAIN STEAM PIPE CONNECTIONS WITH BOILERS.

Suppose a boiler is supplying steam to an engine cutting off at, say, one-third of the stroke—that is, admitting steam about one-third of the time? Assuming a maximum velocity in the supply

pipe of 6000 feet per minute, if steam is passing through the same only one-third of the time, the average velocity will be 2000 feet per minute. Basing the size of main steam connections with boilers on this velocity gives the following size pipes when the steam pressure is 80 pounds. The pipe sizes for higher pressures would, of course, be smaller if computed in the same manner, but it is advisable to use as large pipes as those stated in the table, which conform pretty closely with present boiler practice :

TABLE XXVII.

SIZE OF MAIN STEAM PIPES FOR BOILERS OF HORSE-POWER STATED.—STEAM PRESSURE ASSUMED TO BE 80 POUNDS BY GAUGE ; AVERAGE VELOCITY IN PIPE, 2000 FEET PER MINUTE.

Boiler horse-power.	Pipe area. Square feet.	Size of pipe corresponding. Inches.
50	0.057	3
62½	0.071	3½
75	0.085	4
100	0.114	4½
125	0.142	5
150	0.171	6
200	0.228	7
250	0.285	8
300	0.342	8

NOTE.—Four and one-half inch pipes and valves being an odd size, it is advisable to use 5-inch instead. When globe valves are used in boiler connections, it is well to make the pipes one size larger than when straightway gate valves are used, to compensate for the increased resistance.

SIZES OF STEAM AND EXHAUST PIPES FOR ENGINES.

The steam ports and supply pipes to engines are commonly proportioned on a basis of a maximum velocity flow of 6000 feet per minute. A simple automatic or throttling engine running on, say, 80 pounds steam pressure and taking 30 pounds of steam per horse-power per hour would require about 137 cubic feet of steam at the pressure stated for each horse-power per hour. The admission of steam is cut off anywhere from one-quarter to three-quarter stroke ; seldom over one-half stroke, unless the engine is very much overloaded. If we assume a cut-off of four-tenths of the stroke as a fair basis on which to compute the horse-power for pipes of different sizes we have under these conditions the capacities stated in the following table.

TABLE XXVIII.

SIZES OF SUPPLY PIPES FOR STEAM ENGINES.

Nominal diameter of pipe in inches.	Engine horse-power supplied.
2.....	24
2½.....	35
3.....	54
3½.....	72
4.....	92
4½.....	117
5.....	145
6.....	210
7.....	283
8.....	364

Engines exhaust during almost the entire stroke—say 95 per cent. as a fair average. On this basis, assuming 1 pound back pressure, 30 pounds steam per horse-power per hour and a maximum velocity through the exhaust pipe of 5000 feet per minute, the appropriate horse-power for exhaust pipes of given sizes has been computed and is stated in the following table: [4000 feet velocity is a not uncommon velocity to assume.]

TABLE XXIX.

SIZES OF EXHAUST PIPES FOR STEAM ENGINES.

Nominal diameter of exhaust pipe in inches.	Engine horse-power.
2½.....	20
3.....	30
3½.....	40
4.....	50
4½.....	63
5.....	80
6.....	115
7.....	153
8.....	200
10.....	312

A comparison of Tables XXVIII and XXIX shows the size exhaust pipe for a given horse-power to be one size larger than the steam pipe, which accords very well with the general practice of engine builders. Some engine builders make their steam and exhaust connections abnormally large to provide for cases where the pipe lines are long. The foregoing tables give permissible sizes that may be used in proportioning the piping in office and other buildings having individual or isolated mechanical plants.

EFFECT OF BACK PRESSURE ON SIMPLE AUTOMATIC ENGINES.

With a simple automatic engine carrying a back pressure of 5 pounds the loss in power due to back pressure will be as follows: Take, for example, a high speed engine commonly used to drive a direct connected dynamo. With 90 pounds initial gauge pressure, equal to about 105 pounds absolute pressure, and steam cut off at one-quarter stroke, the average pressure per square inch on the pushing side of the piston throughout the stroke will be about 63 pounds.

From this must be deducted the atmospheric pressure, equal to 15 pounds per square inch, or say 16 pounds, to allow for the resistance of the exhaust pipe and elbows. The mean effective pressure, equal to the average pressure on the pushing side of the piston minus that on the exhausting side is $63 - 16 = 47$ pounds. Now with 5 pounds back pressure, or a total of 20 pounds above a vacuum, the steam pressure on the pushing side remaining the same, the mean effective pressure will be $63 - 20 = 43$ pounds. The horse-power will be in proportion to the mean effective pressures computed above; that is, with 5 pounds back pressure the engine will have only $\frac{43}{47}$ ths or $91\frac{1}{2}$ per cent. of the horse-power it has when exhausting freely to the atmosphere. In other words the loss in power due to the back pressure would be nearly 9 per cent.

EFFECT OF BACK PRESSURE ON COMPOUND ENGINES.

The effect of back pressure is a more serious matter in the case of compound engines than with simple ones, since it acts on the relatively large area of the low pressure piston. To show to what extent the engine horse-power is reduced by a 5-pound back pressure on a compound engine, take for example an engine with a 16-inch high pressure cylinder, a 24-inch low pressure cylinder and a 16-inch stroke. A 5-pound back pressure exerted over the large area of the low pressure piston would with a piston speed of 600 feet per minute amount to 452 (square inches) $\times 5$ (pounds) $\times 600$ (feet) $\div 33,000$ (foot pounds per horse-power) = 41 horse-power. Such an engine with 125 pounds gauge pressure when run non-condensing is rated to develop about 225 horse-power, hence an increase in the back pressure of 5 pounds decreases the effective output of the engine about one-fifth or 20 per cent.

COUNTERACTING BACK PRESSURE BY INCREASED BOILER PRESSURE.

With a back pressure exhaust heating system either larger engines must be used to secure a given horse-power or a higher boiler pressure must be carried. If the latter is done considerably more than the 5 pounds back pressure commonly allowed on the engine must be added to the boiler pressure, since the back pressure is maintained throughout the stroke of the engine, but the boiler pressure is cut off at one-quarter, one-third, or some other point of the stroke, as the case may be. To counteract 5 pounds added to the back pressure of an engine cutting off at one-quarter stroke about 8 pounds must be added to the boiler pressure. A few pounds added in this way is not a serious matter so far as fuel consumption is concerned, since the total heat necessary to make steam increases very slowly with an increase in pressure and not at all in proportion to the pressure increase. With ordinary tubular boilers, however, the allowable pressure that may be carried is cut down from time to time by the insurance companies, so that if 10 pounds more pressure must be carried, for example, to overcome a certain back pressure than would otherwise be necessary, the boiler must be condemned so much the sooner.

STEAM HEATING IN CONNECTION WITH CONDENSING ENGINES.

In the case of plants having condensing engines, either simple or compound, the question arises whether it is better economy to run the engines noncondensing part of the time and heat with the exhaust steam, or to always run them condensing and heat with live steam. Which is the better policy depends chiefly on the amount of steam required for heating in comparison with the total exhaust from the engines. If the amount is very small manifestly it would be better to run condensing and secure the marked saving in steam and supply the heating system with live steam through a reducing valve. When there are several engines it is well to have the exhaust pipes connect with a header with cut-out valves between the engines, one end of the header connecting with the condenser and the other with the line leading to the heating system. Then one, two or more engines may be run condensing and the others exhaust to the heating system.

As to the economy: Suppose a compound condensing engine will develop an indicated horse-power with the consumption of



16 pounds of steam per horse-power per hour, and will require 23 pounds of steam to develop a horse-power when running non-condensing, a difference of 7 pounds. Under the conditions stated a 300 horse-power engine would consume when running noncondensing $300 \times 23 = 6900$ pounds per hour. If the engine were run condensing it would consume $300 \times 16 = 4800$ pounds. In the case assumed whenever more than $6900 - 4800 = 2100$ pounds of steam per hour are required by the heating system it will be cheaper to run noncondensing.

Suppose for example that 3600 pounds of steam are necessary to supply the heating system for one hour. If the engine is run condensing 4800 pounds of exhaust steam will be condensed and 3600 pounds of live steam must be supplied, a total of 8400 pounds in one hour, whereas if the engine were run noncondensing 6900 pounds of exhaust steam would be secured, of which 3600 would be used for heating, the rest escaping through the exhaust head, except that utilized in heating the feed-water.

With the steam consumption assumed, whenever more than 7 pounds of steam may be utilized in the heating system to each horse-power developed by the engine it would be better economy to run noncondensing. When less than 7 pounds is needed the engine should be run condensing. For example, suppose steam is required by the heating system at the rate of 4 pounds to each horse-power developed by the engine, one horse-power condensing will take 16 pounds of steam, which, plus the 4 pounds of live steam supplied to the heating system, amount to 20 pounds per engine horse-power, whereas if the engine were run noncondensing 23 pounds would be consumed. Against this method of heating must be charged the larger size engine required to produce a given horse-power when running noncondensing.

In the case of a Corliss simple noncondensing engine taking, say, 26 pounds of steam per horse-power per hour and 21 pounds when condensing, it will be found cheaper to run noncondensing whenever the heating demands more than 5 pounds of steam to each horse-power developed by the engine; in other words, whenever the steam for heating exceeds more than about one-fourth that for power it will be better economy to run noncondensing, and when less than that amount to run condensing.

CHAPTER X.

CAPACITIES OF PIPES FOR HOT WATER HEATING.

THE FLOW OF WATER IN PIPES.

The force causing circulation in a hot water heating system, due to the difference in temperature of the water in the supply and return pipes, is very slight and amounts to only 1 grain, or 1-7000 pound per square inch per degree difference in tempera-

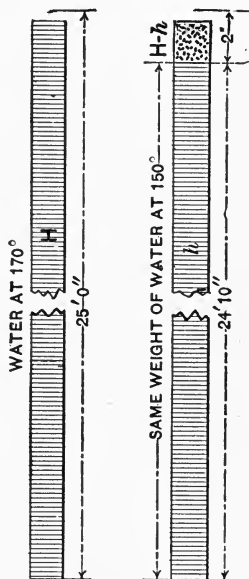

Fig. 33.—Head of Water Causing Flow.

ture per foot of hight. In ordinary two-pipe up-feed systems the hight is to be considered as that between the middle of the boiler and that of the topmost radiator. Suppose the supply and return risers to be 25 feet high with 20 degrees difference in temperature, then the excess of weight in the return over that in the supply line will be $25 \times 20 = 500$ grains = 1-14 pound for each square

inch cross sectional area. Since 1 pound pressure is equivalent to about 2.3 feet, 1-14 pound is equal to a head of, approximately, 0.165 feet, or about 2 inches.

Put in another way, let H in the accompanying sketch represent the height of a column of water at 170 degrees and h the height of a column of equivalent weight at 150 degrees. Let $H = 25$ feet, then

$$h = \frac{25 \times 60.801 \text{ (weight of 1 cubic foot at 170 degrees)}}{61.204 \text{ (weight of 1 cubic foot at 150 degrees)}}$$

$= 24.835$ feet. Then, $H - h$, the height representing the head or unbalanced force causing circulation of the water, is 0.165 foot, or about 2 inches, as above.

Were it not for friction the velocity corresponding to this head would be about 195 feet per minute, since the velocity in feet per second, neglecting friction, is approximately eight times the square root of the head, expressed in feet. Friction, however, plays a very important part in the laws governing the flow of water in pipes, and the actual velocity is only a fraction of the theoretical velocity, computed as above. The resistance to the flow is proportional to the length of the pipe to the square of the velocity, and decreases as the diameter increases. That is, the resistance varies inversely as the diameters.

VOLUME OF WATER TO SUPPLY RADIATORS.

The volume of water that must pass through a radiator of a given size to maintain a certain output of heat may be determined as follows: Take, for example, a direct radiator of 100 square feet, in which the water is cooled 15 degrees and which gives off 150 heat units per square foot per hour. The heat given off equals 100×150 , or 15,000 heat units per hour. Since the water is cooled 15 degrees, each pound gives up 15 heat units; therefore, 1000 pounds must be cooled in an hour. Suppose the water enters at 170 degrees. Table XXX, herewith, shows that water at this temperature weighs 60.801 pounds per cubic foot. Therefore, $1000 \div 60.801$, or 16.41 cubic feet, must pass through a 100 square foot radiator to give up the heat units stated. This number of cubic feet multiplied by $7\frac{1}{2}$ gives the number of gallons required—viz., 123.1.

TABLE XXX.
VOLUME AND WEIGHT OF DISTILLED WATER.
"Weisbach."

Temperature in degrees F.	Weight of a cubic foot in pounds.	Temperature in degrees F.	Weight of a cubic foot in pounds.
32	62.417	170	60.801
39.1	62.425	180	60.587
40	62.423	190	60.366
50	62.409	200	60.136
60	62.367	210	59.894
70	62.302	212	59.707
80	62.218	220	59.641
90	62.119	230	59.372
100	62	240	59.096
110	61.867	250	58.812
120	61.720	260	58.517
130	61.556	270	58.214
140	61.388	280	57.903
150	61.204	290	57.585
160	61.007	300	57.259

THE VELOCITY IN HOT WATER HEATING PIPES.

To compute the velocity in pipes, suppose, for example, a 2-inch pipe supplies 200 square feet of surface, the water to drop 20 degrees in passing through the radiator. This amount of surface will give off about 200×150 heat units = 30,000 heat units per hour. Suppose the water enters at 170 degrees, weighing 60.801 pounds per cubic foot. Each pound gives up 20 heat units; then, $30,000 \div (60.801 \times 20)$ 24.6 cubic feet must pass through the radiator per hour, equal to about 0.41 cubic foot per minute. A 2-inch pipe has an area of 0.0233 square foot, therefore the velocity must be about 17.6 feet per minute, or 0.293 foot per second.

The velocities in the pipes of hot water heating systems are very low, as they must be, for the water to circulate with the small head, due to the difference in temperature between the water in the flow and return pipes.

RADIATING SURFACE SUPPLIED BY PIPES OF DIFFERENT SIZES.

If the volume of water passing through pipes of different sizes is known, the radiating surface they will supply may be readily computed. With the same drop in temperature in radiators, the force causing circulation will be alike in all. With pipes of equal length the resistance will vary as the square of the velocity, and

inversely as for the diameter expressed, as $\frac{v^2}{d}$.

Now, if we assume, for example, that a 2-inch pipe will supply 200 square feet of direct radiation—which in practice it will readily do—and compute the value of $\frac{v^2}{d}$, then make $\frac{v^2}{d}$ the same for pipes of other sizes, a table may be prepared showing the radiating surface that may be supplied by pipes of different diameters when working under the same conditions with respect to the head causing the flow and the resistance to the circulation. This has been done, and the results are stated in the following table:

TABLE XXXI.

THE CAPACITY OF MAINS 100 FEET LONG EXPRESSED IN THE NUMBER OF SQUARE FEET OF DIRECT HOT WATER RADIATING SURFACE THEY WILL SUPPLY WITH THE OPEN TANK SYSTEM, WHEN THE RADIATORS ARE PLACED IN ROOMS AT 70 DEGREES F.

Nominal diameter of pipes.	Capacity in square feet of direct radiating surface.	Actual inside diameter in inches.	Actual inside diameter in feet.	Area in square inches.	Area in square feet.	Capacity in gallons per foot length.
1¼	75	1.38	0.125	1.49	0.0104	0.0777
1½	107	1.61	0.134	2.04	0.0141	0.1058
2	200	2.07	0.172	3.35	0.0233	0.1743
2½	314	2.47	0.206	4.78	0.0332	0.2483
3	540	3.07	0.256	7.39	0.0513	0.3835
3½	780	3.55	0.296	9.89	0.0687	0.5136
4	1,060	4.03	0.333	12.73	0.0884	0.6613
4½	1,410	4.50	0.375	15.94	0.1108	0.829
5	1,860	5.04	0.417	19.99	0.1388	1.038
6	2,960	6.06	0.500	28.89	0.2066	1.500
7	4,280	7.02	0.583	38.74	0.2690	2.012
8	5,850	7.98	0.666	50.04	0.3474	2.599

NOTE.—The above ratings in the second column are based on buildings having not more than three floors above the basement. With higher buildings the capacities would be increased.

It is of some interest to compare with Table XXXI the pipe capacities that have been presented in various publications and trade catalogues. Table XXXII gives such a comparison, and shows a wide variation in the computed capacities stated by various engineers:

TABLE XXXII.

THE CAPACITY OF HOT WATER HEATING MAINS EXPRESSED IN THE NUMBER OF SQUARE FEET OF DIRECT RADIATING SURFACES SUPPLIED.

Diameter of pipe. Inches.	A.	B.	C.	D.	E.	F.	G.
1	39	44	30	50	89
1¼	64	69	78	60	90	140
1½	95	100	111	100	130	200	202
2	156	176	184	200	250	325	359
2½	256	275	260	350	400	450	561
3	381	400	405	550	540	700	807
3½	531	540	576	850	740	900	1,099
4	706	710	784	1,200	890	1,200	1,436
4½	906	890	990	1,100	1,500	1,817
5	1,131	1,100	1,240	1,600	2,000	2,244
6	1,525	1,600	1,920	3,000	3,228
7	2,150	2,760	4,200	4,396
8	2,750	3,570	5,600	5,744
9	3,625	7,268
10	4,525	6,050	8,976

Authorities.

A—J. L. Bixley; B—J. H. Kinealy; C—J. L. Mott Iron Works; D—C. L. Hubbard; E—R. C. Carpenter; F—Model Heating Company; G—Nason Mfg. Company.

PIPE SIZES FOR INDIRECT HEATING.

Since indirect radiators are placed at a much lower level, with reference to the heater, than are direct radiators, the head corresponding to the difference in temperature between the supply and the return pipes is much less than is the case with the latter, and scarcely exceeds 1-20 foot. Since cold air comes in contact with the radiators, the loss of heat per square foot is much greater than from direct radiators. These two causes make it necessary to provide much larger pipes to supply a given amount of surface than in the case of direct radiators.

For supplying indirect radiators, C. L. Hubbard recommends using 1¼-inch pipes for 30 square feet, 1½-inch for 31 to 50, 2-inch for 51 to 100, 2½-inch for 101 to 200, 3-inch for 201 to 300, 3½-inch for 301 to 400, and 4-inch for 401 to 600. Baldwin recommends allowing a 2-inch pipe to 100 square feet of indirect radiation. This rule gives much larger pipes than customary. Certain hot water fitters use 1¼-inch pipes to 60 square feet, 1½-inch for 61 to 120, and 2-inch for 121 to 240 square feet. With pipes carrying so much radiating surface as the latter, the drop in temperature of the water in passing through the radiators must

be greater than when larger pipes are used. The objection to small pipes, with consequent increased drop in temperature to overcome resistance, is that the mean temperature of the radiator is lowered, and the heat given off per square foot is diminished. What is saved in piping must be made up in radiation.

The writer considers it unwise to supply more than 200 square feet of indirect radiation with a 2-inch pipe, and prefers rating a 2-inch pipe to supply 150 square feet of indirect surface. Taking the latter as a basis, pipes of other sizes would supply the surface stated in Table XXXIII when working against the same resistance, which varies as the square of the velocity and inversely as the diameter.

TABLE XXXIII.

THE CAPACITIES OF PIPES EXPRESSED IN THE NUMBER OF SQUARE FEET OF INDIRECT HOT WATER RADIATING SURFACE THEY WILL SUPPLY WITH THE OPEN TANK SYSTEM.

Diameter of pipes. Inches.	Indirect radiating surface. Square feet.	Diameter of pipes. Inches.	Indirect radiating surface. Square feet.
1¼	56	4	790
1½	80	4½	1,060
2	150	5	1,400
2½	235	6	2,220
3	405	7	3,200
3½	585	8	4,400

SIZES OF RISERS.

The capacities of risers recommended by different writers are as follows:

TABLE XXXIV.

COMPARISON OF RATINGS FOR HOT WATER RISERS.
(Height of floors approximately 10 feet each.)

Sizes of pipes. in inches.	—First-floor risers.—				—Second-floor risers.—			
	Square feet direct radiation.				Square feet direct radiation.			
¾	27	...	50	...	35	...	52	
1	39	48	30	89	45	62	55	92
1¼	64	75	60	140	73	97	90	144
1½	95	108	100	202	110	140	140	209
2	156	191	200	359	179	250	275	370
2½	256	300	350	561	294	390	475	577
3	381	430	550	807	438	835
3½	531	590	850	1,099	610	1,132
4	706	770	...	1,436	812	1,478
4½	906	970	...	1,817	1,042	1,871
5	1,131	1,200	...	2,244	1,301	2,309
6	1,525	1,700	...	3,228	1,753	3,341

	—Third-floor risers.—				—Fourth-floor risers.—			
	Square feet direct radiation.				Square feet direct radiation.			
¾.....	...	35	...	53	55
1.....	48	62	65	95	52	...	75	98
1¼.....	79	97	110	149	85	...	125	153
1½.....	118	140	165	214	126	...	185	222
2.....	194	250	375	380	206	...	425	393
2½.....	318	390	...	595	338	613
3.....	473	856	503	888
3½.....	659	1,166	701	1,202
4.....	876	1,520	932	1,571
4½.....	1,124	1,927	1,196	1,988
5.....	1,402	2,376	1,493	2,454
6.....	1,891	3,424	2,013	3,552

The figures stated in the first, second, third and fourth columns, giving capacities, are by Bixley, Kinealy, Hubbard and Nason, respectively. It will be noted that here, as in the case of mains, the capacities given by the Nason Company are much in excess of others. The figures given by Prof. Kinealy are based on water at high temperature and may be increased 25 per cent. for water at 160 degrees in the radiator.

The following table has been compiled by the writer, using as a basis a 1½-inch pipe rated to supply 100 square feet of direct radiation on the first floor, 140 square feet on the second, 175 square feet on the third and 200 square feet on the fourth. The capacities of other pipes are based on a flow that represents the same resistance to be overcome as in the 1½-inch pipes, as above rated; that is, the capacities of pipes larger than 1½-inch are based on a higher velocity and smaller pipes on a correspondingly lower velocity, since the resistance varies directly as the square of the velocity and inversely as the diameter.

TABLE XXXV.

THE CAPACITIES OF RISERS EXPRESSED IN THE NUMBER OF SQUARE FEET OF DIRECT HOT WATER RADIATING SURFACE THEY WILL SUPPLY ON DIFFERENT FLOORS.—FLOOR HEIGHTS APPROXIMATELY 10 FEET.—OPEN TANK SYSTEM.—RADIATORS IN ROOMS AT 70 DEGREES F.

Diameter of riser. in inches.	—Square feet of direct radiating surface supplied.—			
	First floor.	Second floor.	Third floor.	Fourth floor.
1.....	33	46	57	64
1¼.....	71	104	124	142
1½.....	100	140	175	200
2.....	187	262	325	375
2½.....	292	410	492	580
3.....	500	755	875	1,000

RADIATOR CONNECTIONS.

Direct hot water radiators are commonly tapped 1 inch up to 40 square feet, 1¼ inches for 41 to 72 square feet, and 1½ inches for ordinary sizes larger than 72 square feet.

ELBOWS AND BENDS.

The resistance interposed by elbows to the passage of water is a subject on which there appears to be little available data of value. Fortunately, it is unnecessary, in ordinary heating work, to compute the loss of heat due to this resistance. The writer, in a series of articles on the flow of steam, gives a table showing the lengths of straight pipe that would present the same resistance as a standard elbow. The values there given will be found convenient for use in case it is desired to allow for the resistance of elbows in an extensive system of hot water heating.

In the smaller sizes of fittings, say from $1\frac{1}{2}$ to 4 inches, the radius of the center line of the elbow is roughly $1\frac{1}{4}$ x the diameter of pipe for standard elbows; $1\frac{3}{4}$ x the diameter of pipe for the long turn patterns and $2\frac{1}{4}$ x the diameter of pipe for extra long turn elbows. The relative resistance, or loss of head, computed from Weisbach's formula is, for these three patterns, as follows: Standard, 100; long turn, 83; extra long turn, 77. While these figures may be considered merely approximate, they serve to show in a general way the great advantage of long turn elbows over those of standard patterns for hot water work.

Ordinary wrought iron or steel pipe bends have a radius of axis equal to, at least, 5 x the diameter of pipe. With such bends, Trautwine states, the flow will not be materially diminished. In first-class hot water heating plants long turn elbows are used, and the ends of the pipes are reamed inside to reduce, as far as possible, the resistance to the flow of water and to permit the least difference possible between the temperature in the supply and return pipes.

EXPANSION TANKS.

Hot water expands about 4 per cent. of its volume at 40 degrees when heated to 200 degrees. Taking these as the extremes of temperature between the water when the system is first filled and when operating in coldest weather, and assuming that the expansion tank should have a capacity equal to twice this increase in volume, the tank should be made 8 per cent., or about one-twelfth, of the total volume of radiator and piping. Suppose the piping is equivalent to one-third the direct radiating sur-

face and the volume of water in the system to amount to $1\frac{1}{2}$ pints per square foot of radiating surface, including mains, then, for example, a 10-gallon expansion tank would be adapted to a system holding 120 gallons, which, on the basis of $1\frac{1}{2}$ pints per square foot of radiation, mains included, would be 640 square feet. And, since mains are reckoned at one-third the actual surface in radiation, the latter would amount to three-fourths of 640 square feet equal 480 square feet, or, say, in round numbers, 500 square feet. On the same basis the capacity of other tanks would be in proportion, as follows:

TABLE XXXVI.

CAPACITY OF EXPANSION TANKS.

Capacity of tank in gallons.	Capacity in square feet of actual surface in hot water radiator to which tank is adapted.
5	250
10	500
15	750
20	1,000
30	1,500
40	2,000
50	2,500
60	3,000

It will be noted that the capacities in the above table are equivalent to 1 gallon in expansion tank to each 50 square feet of surface in radiators; a convenient rule. While tanks may be made smaller, the saving would be slight, and they would require more frequent attention, unless fitted with an automatic water line regulator.

It is beyond the scope of this work to discuss methods of piping; yet the writer feels constrained to warn fitters against the danger in placing a valve in the expansion pipe, which is sometimes done, and also to see to it that the expansion pipe and tank are located where there will be no danger from freezing.

CHAPTER XI.

VACUUM AND VAPOR SYSTEMS OF STEAM HEATING.

This chapter is made up chiefly of articles that appeared in *The Metal Worker* during the year 1906 under the heading, "Modified Systems in Steam Heating," by "Progress." These articles have been revised and supplemented by others relating to systems that properly come under this heading.

THE WEBSTER SYSTEM.

In the Webster system of steam circulation the steam supply to the radiators is controlled by a hand wheel valve as in the ordinary two-pipe system. At the return end of each radiator is placed a so-called "thermo-valve," Fig. 34, or a water seal motor, Fig. 35, either of which allows the escape of air and water and prevents the escape of steam. Since air is heavier than saturated steam, in the ratio of 1 to $\frac{5}{8}$ at atmospheric pressure, the location of the thermo-valve at the lower end of the radiator opposite the steam inlet is stated to be the most effective one possible. Air valves are not required with the Webster system. Typical radiator connections are shown in Fig. 36. It is essential that each unit of radiation be equipped with one of the valves described, or one performing the same functions, otherwise any unit without one would permit steam to pass into the returns and destroy the vacuum which it is the function of the pump to maintain. By means of this suction a continuous removal of condensation and air from the heating system is secured.

The water drawn from the system is discharged by the vacuum pump to a feed water heater, any air in the system escaping from an air separating chamber provided on the discharge line between the pump and the heater. (See Fig. 37.) The feed water heaters are commonly connected with a branch exhaust pipe, this method of piping being preferred by the patentees of the system to passing all the exhaust steam from the engines through the heater.

The vacuum pump exerts a suction on the return ranging as

a rule from 4 to 15 inches mercury column, according to the length and size of the pipes. With this system high pressure returns must not be connected with the returns leading to the vacuum pump, since the high temperature of the condensation causes the water to vaporize in the returns and interferes with the

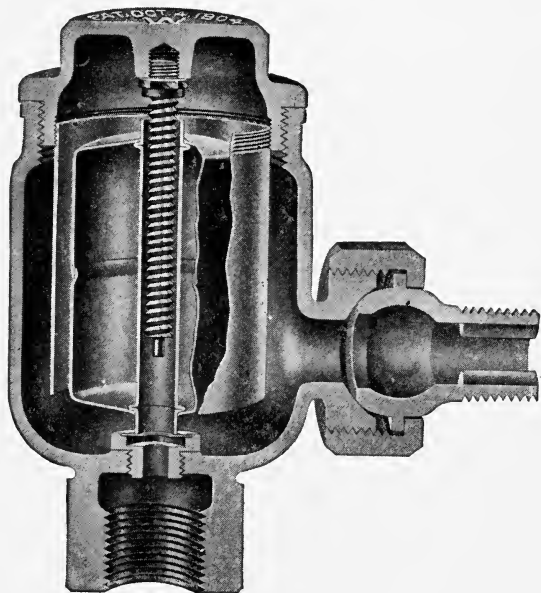

Fig. 34.—Sectional View Webster Water Seal Motor.

maintenance of the vacuum. The exhaust from the pump is utilized in the heating system.

HEATING AT NIGHT.

In buildings heated by this system it is possible to supply an amount of live steam less than that required to completely fill the system at atmospheric pressure, hence a saving may be made by heating at night with steam at a pressure below that of the atmosphere.

It is often desirable to locate some radiating surface at a point lower than the main return. With the Webster system the condensation may be raised several feet above the level of the radiator to be drained by reason of the suction in the returns.

BACK PRESSURE VALVES AND PRESSURE REDUCING VALVES.

The back pressure and pressure reducing valves need not be set to produce initial pressure in the heating mains in excess of that required to supply the most remote unit of radiation with steam at atmospheric pressure. The initial pressure may be

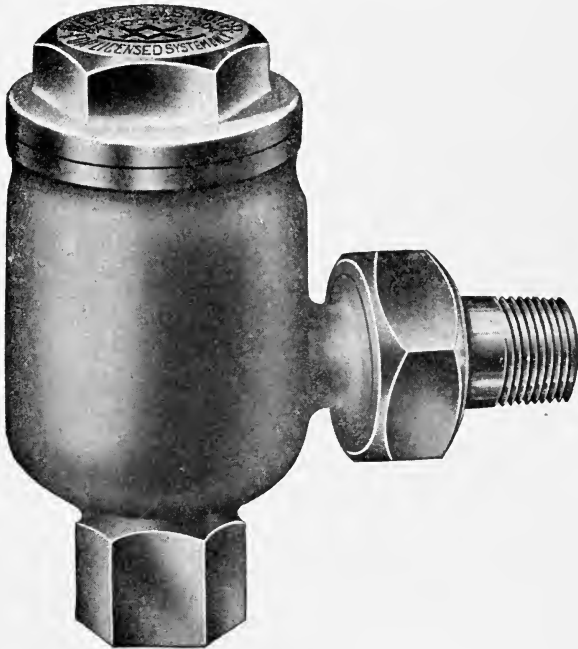

Fig. 35.—Exterior View Webster Water Seal Motor.

varied according to the outside temperature, as required. On high pressure jobs two reducing valves, set tandem, are sometimes installed, the first to reduce from boiler pressure down to 15 or 20 pounds, the latter to reduce to atmospheric pressure or a few ounces above.

ADVANTAGES CLAIMED.

The Webster Company in its publications sets forth these advantages:

1. Absence of back pressure on motive engines when exhaust steam is utilized.

2. A perfect drainage of supply pipe systems preliminary to an equally perfect drainage of radiating surface without the loss of steam.
3. A continuous automatic drainage of condensation and the prevention of any accumulations of water.
4. A positive and consequently effective steam circulation.
5. Perfect control of circulation with power to vary it at will.

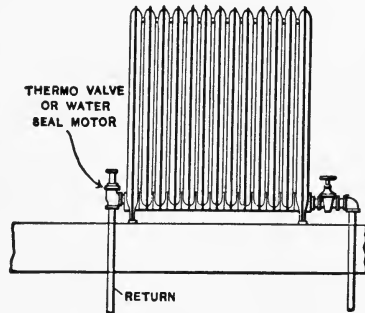

Fig. 36.—Typical Radiator Connections.

6. Removal of air and gases from heating surfaces and feed water.
7. Power to independently modulate temperature in any part of the heating surface.
8. The return of condensation from points somewhat below the line of drip or drainage mains when necessary.
9. Smaller pipes may be used than with the ordinary low pressure two-pipe system.

It is pointed out that the positive removal of air from the radiators is alone a great advantage, since automatic air valves seldom properly perform the function for which they were designed, and unless air lines lead from them to some suitable point of discharge the ill-smelling air from the radiators is discharged into occupied rooms.

Water hammer, due to ignorance or carelessness in operating radiator valves, is entirely overcome by the use of the two-pipe vacuum system. The supply valve is the only one that requires any attention, the return being automatic. The supply of steam may be throttled down at will, and the vacuum maintained on

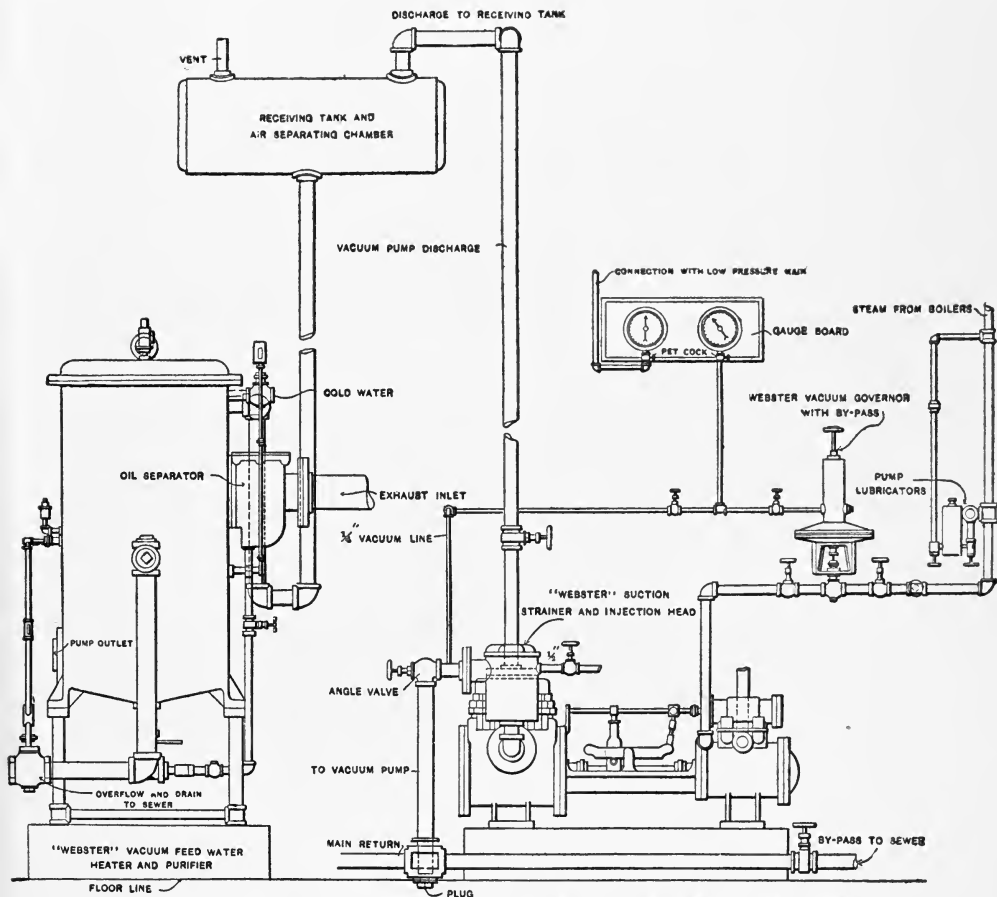

Fig. 37.—Typical Arrangement of Vacuum Pump and Feed Water Heater in Webster Vacuum Heating System.

the returns causes the continuous removal of condensation from the radiators and prevents any backing up of water.

The steam pressure in the radiators is not reduced by the vacuum maintained on the return, but depends solely on the amount of steam admitted to the radiators. Indirectly the vacuum on the return affects the steam pressure, since no pressure whatever above the atmosphere is required in the radiators for the purpose of forcing the water of condensation through them and the air out of them. In the case of old plants having insufficient radiation for the most severe weather, when using the very low pressures common with vacuum systems it is often better policy to carry a few pounds back pressure on the engines furnishing the exhaust steam during such weather than to overhaul the entire heating system.

This system secures the ready circulation of steam throughout buildings widely separated, and that, too, with only a slight back pressure on the engines. With the usual methods of steam heating it is necessary to carry a back pressure, even during mild weather, when the full efficiency of the radiating surfaces is not required, and when but few of the radiators of an extensive system may be needed. Under certain conditions it would be cheaper to supply live steam at reduced pressure than to carry back pressure on the engines in order to supply a small amount of radiating surface.

PIPE SIZES.

Since with this system no pressure is necessary in the radiators to force out the air and water, it follows that a drop in pressure of only a few ounces from the initial pressure will be sufficient to cause the necessary flow of steam through the pipes.

These may be made smaller than is customary with the ordinary two-pipe low pressure system, and the returns may be decidedly cut down in size owing to the action of the vacuum pump creating a rapid flow in them. See pipe sizes, pages 92 and 93. The supply pipes may be made one or two sizes smaller with the vacuum system, and the returns two to three sizes smaller than would be used with the ordinary low pressure system.

THE PAUL SYSTEM.

The Paul system secures the removal of air from radiators through air valves of the expansible plug type connected with air lines leading to a steam ejector. See Fig. 38. It may be applied either to one-pipe or two-pipe systems (see Figs. 39 and 40), the water returning in the same manner as in ordinary low

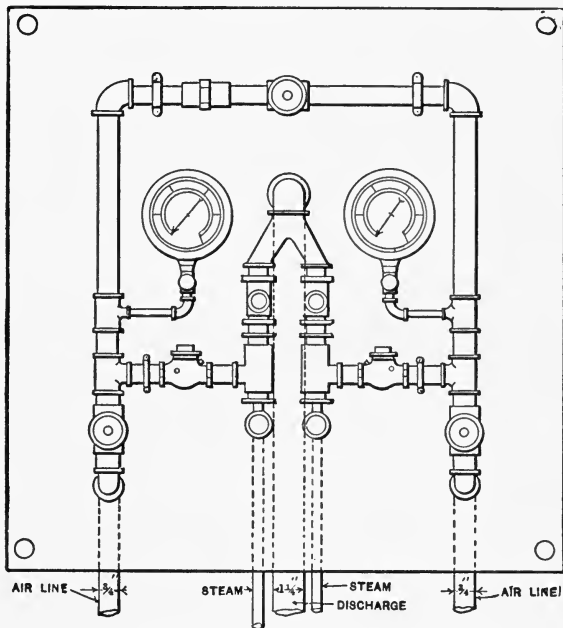

Fig. 38.—Front Elevation of Paul Exhausting Apparatus.

pressure steam heating plants. This system handles the air alone, whereas the Webster system removes both the air and condensation from radiators.

That air is the most serious hindrance to the proper operation of a steam heating plant is a well-known fact. To attempt to get rid of it by forcing it through ordinary automatic air valves by steam pressure is a rather slow process, especially in the case of large coils or radiators. With a common low pressure system the air remains in the radiators until forced out by the steam. With the vacuum system the air may be removed from the radia-

tors by starting the ejector before steam is turned on the system. The radiators then become quickly filled with, and remain full of,

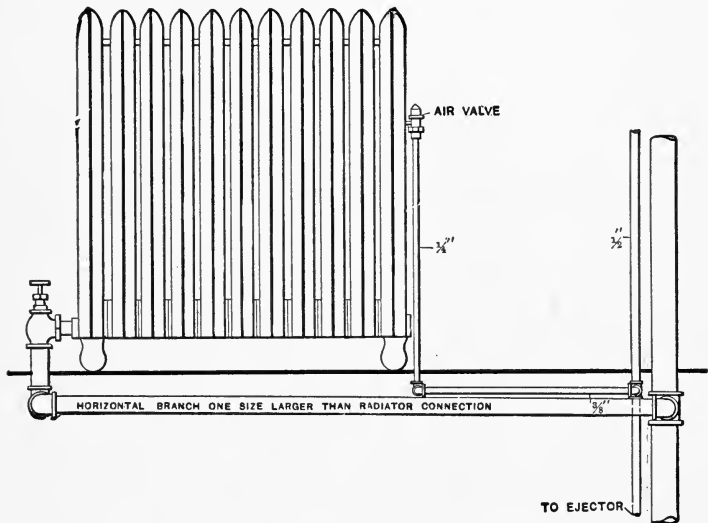

Fig. 39.—Paul System Connections for One-Pipe System.

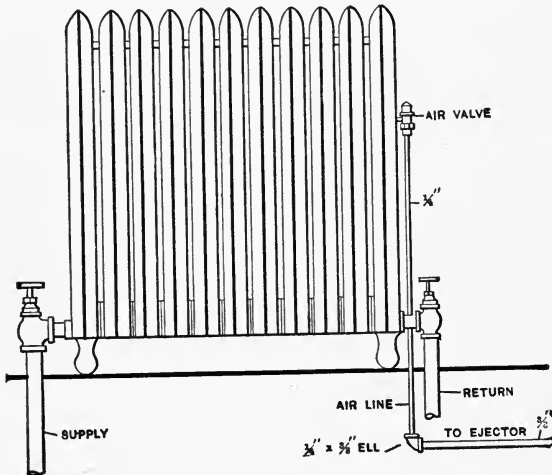

Fig. 40.—Paul System Connections for Two-Pipe System.

steam, since the air is automatically removed as rapidly as it accumulates.

ABSENCE OF BACK PRESSURE.

One of the chief advantages of this system over ordinary low pressure heating is the removal of back pressure from the engines and pumps. This is especially important in modern city buildings, where this system finds its widest application. By exhausting the air from the radiators by means of the steam ejector they become practically condensers, the engines exhausting into them, or, in other words, the radiators draw steam from the engines to them, due to the rapid condensation which they are capable of producing. In manufacturing plants where the power requirements may be in excess of those for heating the importance of the elimination of back pressure is apparent.

STEAM TO OPERATE THE EJECTOR.

As to the amount of live steam required to operate the ejector, it is claimed this amounts to but little if the plant is properly operated, since after the system has once been cleared of air it accumulates slowly and may be removed with the expenditure of a small volume of live steam.

To compute the volume of steam escaping from an orifice to the atmosphere, allow about 900 feet velocity per second and multiply by the area of the opening expressed in the decimal part of a square foot. As to the amount of steam required to operate the ejector, A. B. Franklin in a paper on the Paul system of exhaust steam heating, read before the Master Steam and Hot Water Fitters' Association of the United States, June 7; 1893, states that in ten hours' run, with a fan system of heating having heaters containing an aggregate of 24,150 linear feet of 1¼-inch pipe, supplied by a 6-inch main, the ejector discharging to a condenser used 300 pounds of steam in that length of time. A test made at the Ohio State University showed the total weight of water returned from the radiators to be 8160 pounds and the steam used by the exhauster or ejector to be 432 pounds.

ADVANTAGES CLAIMED.

Claims for the Paul system are:

1. A positive and uniform circulation of steam without pressure above that of the atmosphere.
2. Utilizing the heat of steam at low temperatures, thereby gaining great economy.

3. Warming without impairing the quality of the air in the rooms.

4. The independent and automatic removal of the air and water of condensation from the heating apparatus.

5. A sealed system; no leakage, no smell or dripping from air valves.

6. All heating surface held in the best condition to operate promptly when desired, and all parts of the surface rendered uniformly efficient when steam is turned on.

7. Exhaust steam utilized without back pressure at engine or pumps.

8. The water of condensation returned quickly and economically at highest temperatures.

9. Less steam used, less coal burned, to heat a given space.

HEATING WITH RADIATORS AT A RELATIVELY LOW TEMPERATURE.

Professor Kinealy, reporting on some tests to show the effect of the relatively low temperatures secured by the use of a vacuum system, makes the following statement: "The radiator at high temperature probably kept the air at the top of the room, when the temperature about 5 feet from the floor was 70 degrees, at a much higher temperature than it was kept when the temperature in the radiator was low. The higher the temperature of the air at the ceiling of the room the greater will be the average temperature of the air in contact with the cooling windows and walls of the building, and therefore for a given outside temperature the greater will be the difference between the average temperature of the air inside and that of the air outside, and hence the greater will be the amount of heat transmitted through the cooling walls and windows per hour. As the occupants of heated rooms live in the air which is within 6 feet of the floor, that system of heating must undoubtedly be the best and the most economical which will maintain the desired temperature of the room nearly uniform from the floor to 5 feet above it, with a low temperature in the upper part of the room, and this is, I think, done by radiators supplied with steam at low temperatures." (See "Heating with Steam at or Below Atmospheric Pressure," by J. H. Kinealy, in *The Metal Worker, Plumber and Steam Fitter*, July 29, 1899).

DONNELLY POSITIVE DIFFERENTIAL SYSTEM OF EXHAUST STEAM CIRCULATION.

In this system a controlling valve (see Fig. 41) is placed at the foot of return risers as indicated in Fig. 43. These valves are designed to maintain any desired difference in pressure between

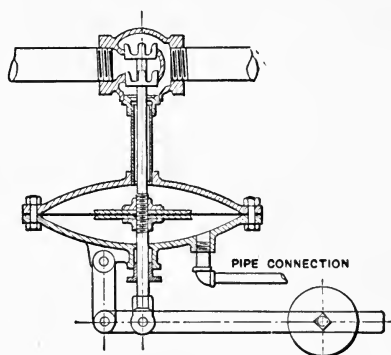

Fig. 41.—Differential Pressure Controlling Valve.

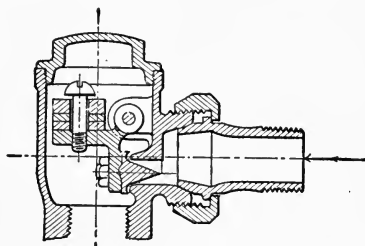

Fig. 42.—Impulse Automatic Valve.

the supply and return risers. By maintaining this constant pressure difference it is claimed that a special type of valve of simple design may be used at the radiator. A small opening is provided for the removal of air when this valve is closed. When open, both air and water pass through it. Valves of other patterns are used, but the impulse valve, so called, shown in Fig. 42, serves to illustrate their use. It is claimed that dirt and scale will freely pass through these valves.

Fig. 43 illustrates the application of this system to coils. The main supply riser is drained through a siphon loop to the return.

It is claimed, since all return risers may be kept in the same condition by means of the controlling valve, that the valve illustrated in Fig. 42 requires little or no adjustment and that all air and condensation is drawn away from the radiating surfaces to the

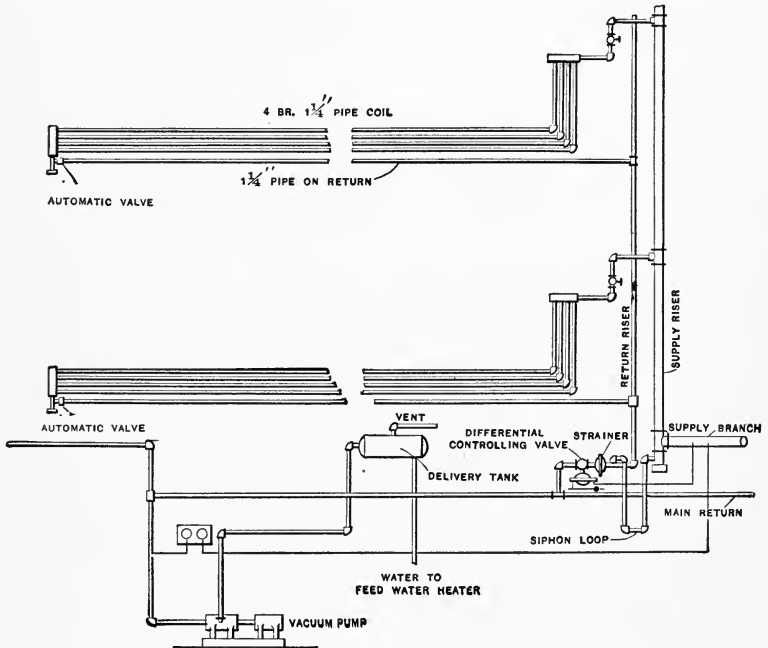

Fig. 43.—Application of the Donnelly System to Radiating Coils.

vacuum pump. It is further claimed that no short circuiting can occur.

THE THERMOGRADE SYSTEM OF STEAM HEATING.

The Thermograde system of low pressure steam heating provides for the control of the heat emitted by radiators by regulating the admission of steam to them. A control valve, illustrated in Fig. 44, is connected with the inlet of each radiator. These valves are intended to be capable of adjustment to admit enough steam to fill one-quarter, one-half, three-quarters or a fractional part of the radiator. When the handle is turned a lug rides up on a cam and raises the disk from the seat.

At the return end of each radiator is placed a combined air valve and expansion trap. This so-called auto valve is designed to allow water and air to escape from the radiator but to prevent the escape of steam. This valve is operated by a liquid sealed in a copper receptacle. When steam comes in contact with it the

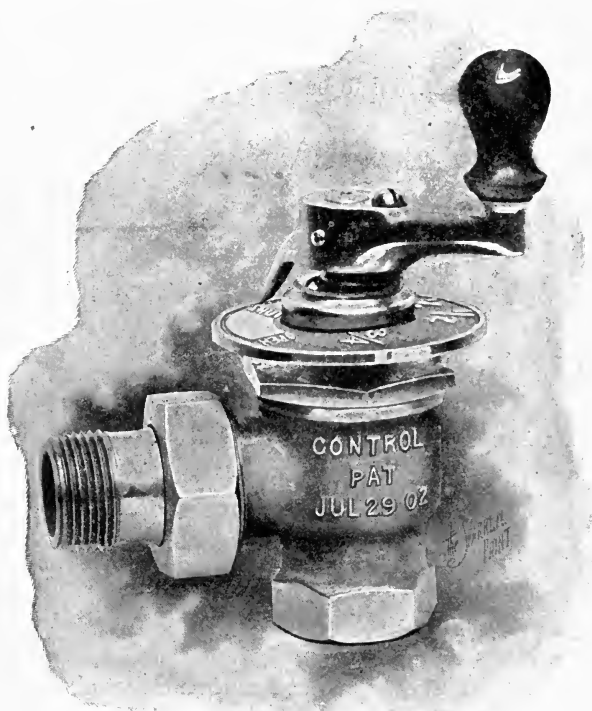

Fig. 44.—The Thermograde Control Valve.

liquid is vaporized and creates a pressure sufficient to force the valve disk against the seat. When the liquid cools, the valve is opened by a spring.

Fig. 45 shows a radiator equipped with the supply and return valves just described. With this system radiators of the hot water type are preferable to those of the ordinary steam pattern, as the control valve may be more conveniently located and because the

circulation in the radiator is said to be somewhat better than with steam radiators.

When a control valve is partially closed the steam is condensed in the upper portion of the radiator, the lower portion is cold and becomes filled with air that backs up through the return valve or trap, the return risers being open to the atmosphere at the top and free from pressure.

When the water of condensation is returned to a low pressure boiler it must be permitted to back up the main return sufficiently

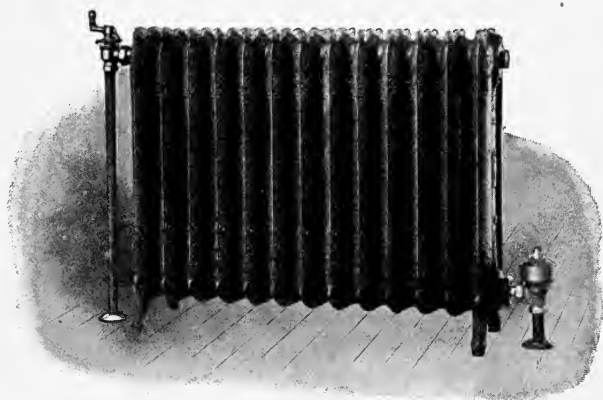

Fig. 45.—Radiator Equipped with Thermograde Valves.

to overcome the boiler pressure acting on the end of the return, where it connects with the boiler.

The lowest radiator should be not less than 6 feet above the water line of the boiler. Since 1 pound pressure is equal to about 2.3 feet, less than 3 pounds boiler pressure could be carried under these conditions without flooding the radiators. The use of a return tank is recommended for large jobs. When the condensation is returned to a tank, as in large buildings, the tank must be vented to the atmosphere.

The piping of a Thermograde system is practically the same as a regular two-pipe system except that the returns must be open to the atmosphere. The main returns are generally run dry. The company controlling this system recommends these sizes for radiator connections:

TABLE XXXVII.

TABLE OF SIZES OF RADIATOR CONNECTIONS.—THERMOGRADE SYSTEM.

Radiator surface. Square feet.	Control valve. Inch.	Drain valve. Inch.	Run-outs from risers to radiators.	
			Supply. Inch.	Return. Inch.
0 to 20.....	$\frac{1}{2}$	$\frac{1}{2}$	$\frac{3}{4}$	$\frac{3}{4}$
21 to 50.....	$\frac{3}{4}$	$\frac{3}{4}$	1	$\frac{3}{4}$
51 to 100.....	1	$\frac{3}{4}$	$1\frac{1}{4}$	1
100 to 150.....	$1\frac{1}{4}$	$\frac{3}{4}$	$1\frac{1}{2}$	1

Advantages claimed for this system are:

1. Positive circulation, due to absence of pressure at the return end of the radiators.
2. Quietness of operation.
3. Control of each unit of radiation independent of others.
4. Absence of separate air valves and lines, these being combined with the return carrying the water of condensation.
5. Convenience in operation, there being but one valve to manipulate.
6. Saving in fuel, due to absence of overheating in rooms, the heating being more easily controlled than with ordinary steam heating systems.
7. The quick heating of radiators, due to the rapid expulsion of air, there being no steam pressure in the returns to be overcome.
8. The drop in pressure between the supply and return lines being greater than in the ordinary two-pipe system, somewhat smaller pipes may be used if necessary.

M'GONAGLE VACUUM SYSTEM FOR LOW PRESSURE PLANTS.

The McGonagle vacuum system provides for an automatic air valve attached to each radiator, and is described about as follows in the publications of the company handling it: To these air valves a system of air piping is attached. This system of air piping terminates in a special trap placed above the water line of the boiler. The discharge from this trap is connected to a return connection of the boiler. A connection is taken from a convenient point in the air line above the trap and connected to the combustion chamber of the boiler furnace. This pipe is supplied with a check valve opening toward the furnace. When steam is generated in the boiler it rises through the steam pipes to the radiators. When the circu-

lation is established the automatic air valves close. These, however, are so adjusted that they will always pass sufficient steam

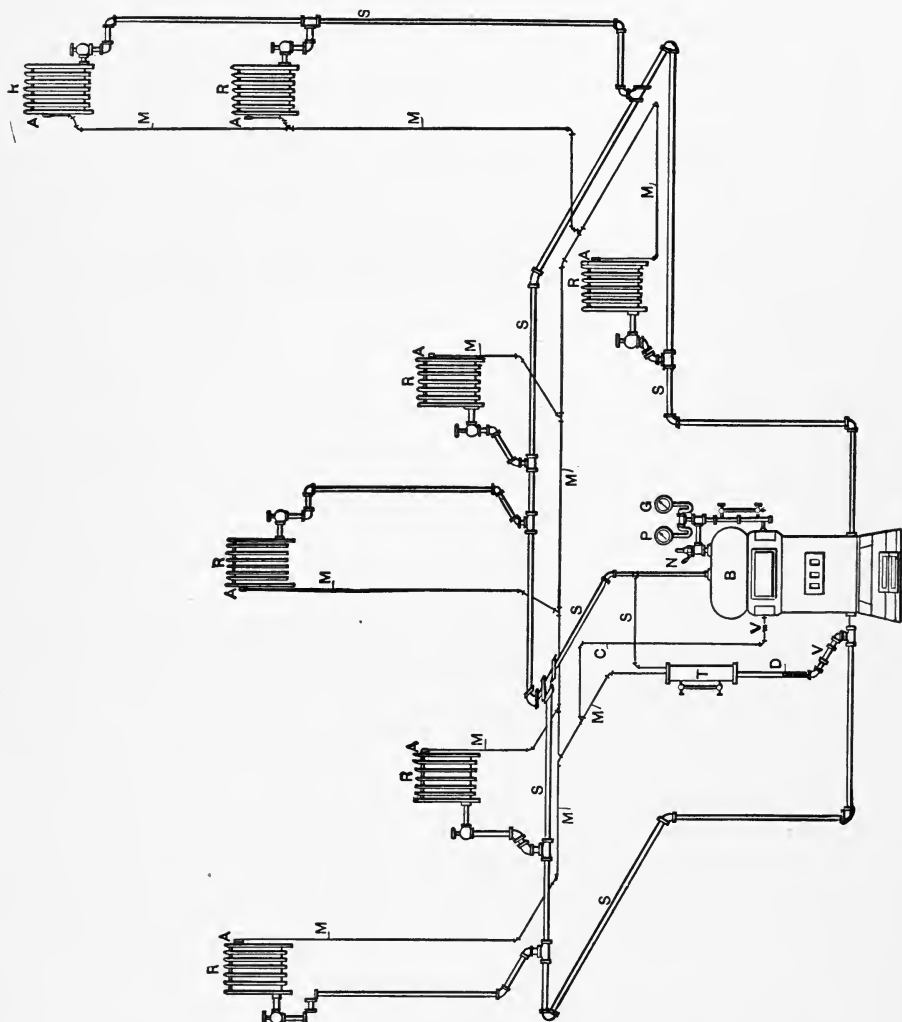

Fig. 46.—Typical Arrangement of the McGonagle Vacuum Heating System.

to keep the air pipe warm for a distance of from 18 inches to 2 feet beyond the air valve.

When the pressure in the air lines drops below the barometer

pressure in the combustion chamber of the boiler the check valve in the pipe to the furnace closes, thus preventing a back flow of the gases from the furnace into the air lines. The regulation of the fire can be accomplished either by hand, in the same manner that a stove is regulated, or by the use of a special draft controller.

The accompanying diagram illustrates the method of installing the McGonagle system. The system is shown as applied to an ordinary one pipe job. The feature of the system is the arrangement of the air piping. If it is desired to apply the system to two-pipe work or to another form of one-pipe work, the arrangement of the air piping should remain the same as shown.

The several parts of the system are designated by the following letters on the cut:

- A. Air valves of special design.
- B. Boiler.
- C. Connection to furnace.
- D. Discharge of trap.
- M. Air pipe.
- R. Radiators.
- T. Trap of special design.
- V. Check valve.
- S. Steam pipe.
- P. Pressure gauge.
- G. Vacuum gauge.
- N. Safety valve.

SUGGESTIONS TO FITTERS.

The radiation intended to heat the rooms should be figured on the same basis that would be used in apportioning radiation for any first-class job which was intended to heat with 2 or 3 pounds pressure. The same size piping should be used and the same care exercised in draining and dripping the pipe that would be necessary if it were intended to erect the apparatus without the use of the vacuum system. Extra precaution should be taken, however, to have all joints tight, and to have all fittings free from sand holes.

Care should be taken that all valves used are carefully packed so as to avoid the leakage of air into the system while the vacuum is being maintained. The manufacturers' packing in the valves should not be depended on but should be removed and carefully replaced with lamp wick dipped in oil and plumbago, being sure

that sufficient wick is used to make the valve tight around the stem. All check valves used should be swing checks, with asbestos or Jenkins' seats. Care should be taken to see that there is no leak of air into the system through the safety valve, water glass, gauge cocks or other trimmings.

The air pipe should not be less than $\frac{1}{4}$ inch between the air valve and the first fitting, where it should increase to $\frac{1}{2}$ inch pipe. The first fitting below the air valve should therefore be a $\frac{1}{4} \times \frac{1}{2}$ inch elbow in every case. No air riser should be less than $\frac{1}{2}$ inch, and where the air riser extends above the second floor or is connected to more than two air valves should not be less than $\frac{3}{4}$ inch. The horizontal air main should be run on the basement ceiling, and need not be larger than 1 inch except in cases of extreme length, where it should be $1\frac{1}{4}$ inches.

In making up the air lines, it is recommended that galvanized fittings be used and that the joints on the air lines be made up of asphaltum and the fittings painted all over on the outside with asphaltum in order to close up any sandholes. Care must be taken to have the air piping tight. Care must also be taken to give the air piping a good pitch of not less than 1 inch to 10 feet toward the boiler. The air piping must contain no pockets or traps of any kind. The connections of the air piping to the air valves should be made with ground joint brass unions.

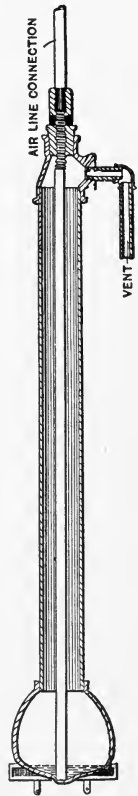

Fig. 47.—Mercury Seal.

THE K-M-C VACUUM SYSTEM.—(MORGAN PATENTS.)

In this system the air is forced out of the radiator by raising the steam pressure in the boiler, and is prevented from re-entering the radiators by means of the mercury seal in which the end of the air line is immersed. Fig. 48 illustrates an ordinary one-pipe job equipped with this system. At point marked O on each radiator is placed a retarder, so-called, consisting of a bent tube of

very small bore, designed to permit the escape of air, but to retard the escape of steam to the air lines.

All the lines leading from the retarders O are joined and lead

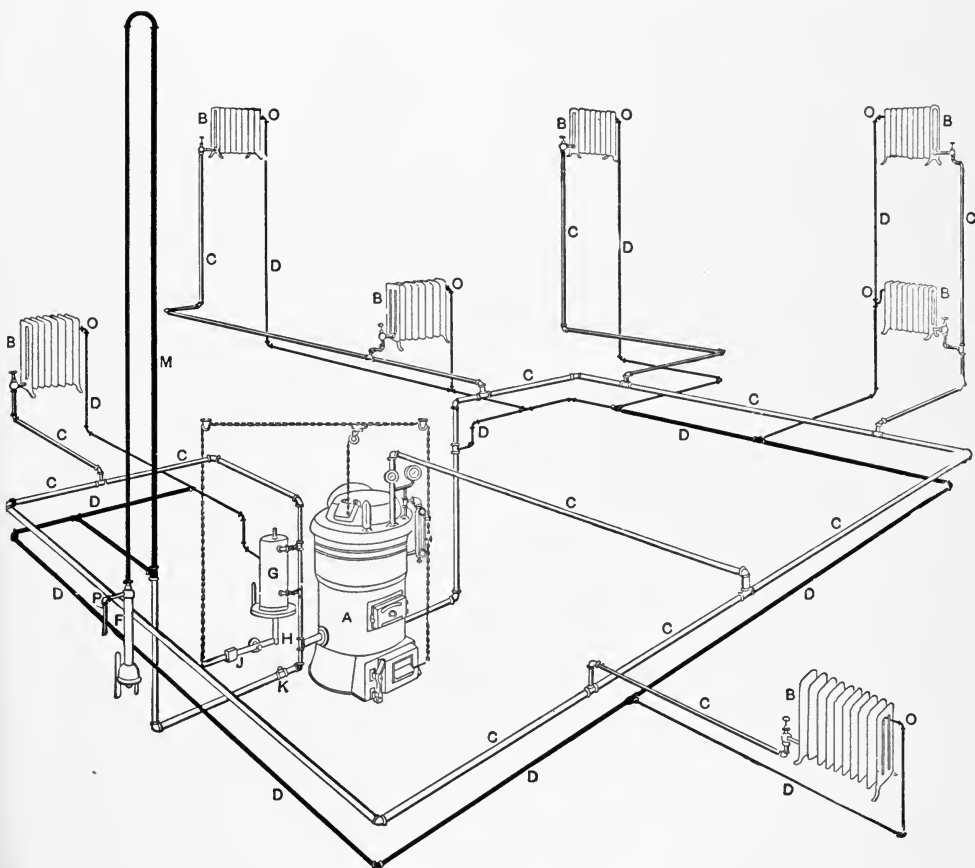

Fig. 48.—Application of Morgan System to One-Pipe Steam Radiation.

to the loop M, which should be extended up a distance not less than 15 feet. The water will back up this loop about 2.3 feet to every pound pressure carried on the boiler. At the foot of the loop a return is run to the boiler with a swing check valve in the return connection. The function of the loop is to condense the steam mixed with air in the vacuum lines connected with the

retarders. The water condensed from this steam backs up the loop until a height is reached that will overcome the pressure against the check valve, when the latter will be lifted and the water will return to the boiler.

From the top of the loop the main air line leads to the center of the mercury seal illustrated in Fig. 47. The lower end of this center tube is submerged in mercury to the depth of $\frac{1}{2}$ inch. After passing through the mercury at the base of the column the air is expelled from the system. By reference to the cut it will be noted that the base which contains the mercury is of greater diameter than the upper part of column. The purpose of this is to hold a quantity of mercury in a thin sheet, which offers little, if any, resistance to expelling the air. As the air will not pass

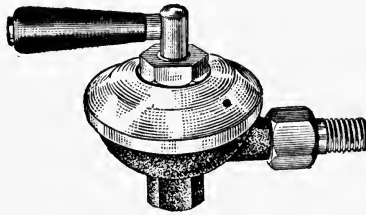

Fig. 49.—The K-M-C Manual Retarder.

down through a liquid more dense than itself it is impossible for the air to return to the system.

The above description applies to small plants. The system may be applied to two-pipe installations, as set forth in pamphlets published by the manufacturers.

In the case of larger plants "manual retarders," so called (See Fig. 49), are used in place of these, with a fixed opening. In operation the manual retarder is designed to allow a free flow of air from the pipes and radiators to the air escape line, but to offer a resistance to the passage of steam and water. The name manual is given from the fact that it is operated by hand and the name retarder from the fact that it prevents the escape of steam. It has no stuffing box or packing, and its operation involves the movement of a disk of Helmut metal. A slow movement of the wheel opens and closes the retarder. The construction provides for self cleaning, so that no accumulation may inter-

ferre with its operation. It may be used on radiators which are provided with valves, and by closing both the retarder and the valve to the radiator complete isolation from the rest of the system is effected. Packless valves are recommended.

An accumulating tank forming a storage chamber in the return from the air main is provided as well as other fixtures not common to the "loop system."

Special stress is laid on the necessity of having a tight job of piping. All superfluous boiler fittings are discarded.

THE TRANE VACUUM SYSTEM.

In the Trane vacuum system air valves of the expansible plug type illustrated in Fig. 50 are attached to the radiators, and air lines are joined and led to the mercury seal shown at A in Fig. 51, which shows a typical lay out of a one-pipe system. This method of piping is considered preferable, not only because of the greater convenience of having but one valve on each radiator, but because the fewer the valves the less the leakage through stuffing boxes, causing the loss of vacuum.

With this system special care must be exercised in packing radiator valves to prevent air leaking into the system and destroying the vacuum. It is claimed, however, that since the valves are used much less frequently than with low pressure systems, as the temperature of the house is approximately controlled by varying the vacuum on the system, the stuffing boxes receive less wear, and if well packed give little trouble from leakage.

This system is so arranged that with a steam pressure of a pound or two, the air in the radiators will be forced through the mercury and out of the system. The air valves prevent the escape of steam from the radiators. When the steam pressure is allowed to fall air is prevented from entering the system by the mercury column which rises in the pipe. The vacuum has no effect on the water line in the boiler, as the pressure on supply and return lines is the same. Of course, it will be necessary from time to time, even in mild weather, to get up sufficient pressure to expel the air from the system, as no job of piping can be made perfectly tight. Every precaution must be taken, however, to make the system as tight as possible, and all lines should be thoroughly

tested with at least 30 pounds pressure, which should be carried for 24 hours without serious loss.

The patentees of this system recommend that gauge cocks be omitted from the water column, as they are sometimes the source of air leakage when the system is running under vacuum. The gauge glasses should be thoroughly packed; the stuffing boxes on

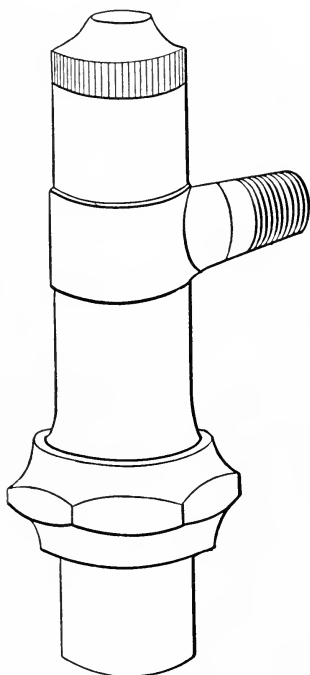

Fig. 50.—Trane System Air Valve.

radiator valves must be tightly packed. The same care must be taken to prevent pockets in the piping as with a regular low pressure system. The patentees recommend that the air pipe and fittings be made of galvanized iron to avoid trouble from stoppage by scale, etc.

Damper regulators of special design are used in connection with mercury seal systems, or thermostatic control may be applied, operating the boiler drafts from the thermostat located at a

point that will represent as nearly as possible the average temperature of the house.

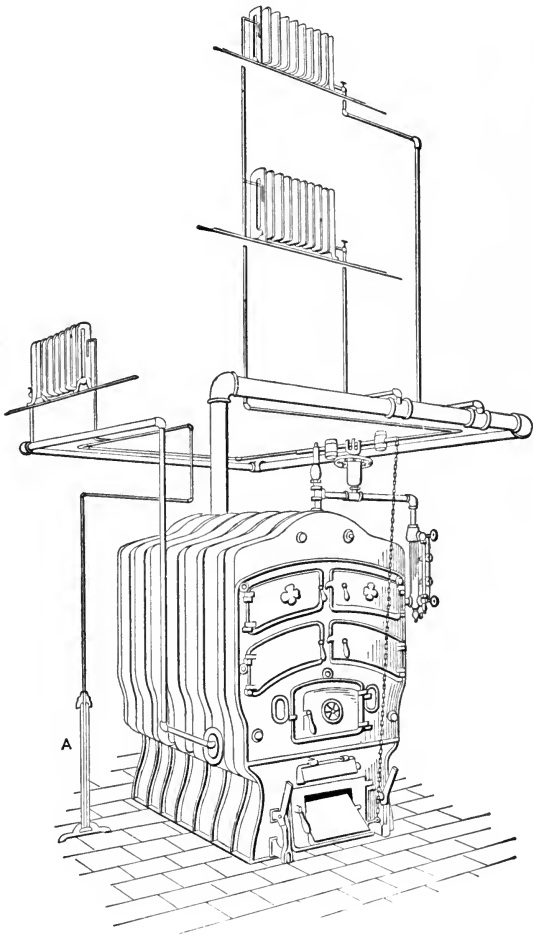

Fig. 51.—Trane One-Pipe Vacuum System.

ADVANTAGES CLAIMED FOR THE MERCURY SEAL VACUUM SYSTEM.

The principal advantages claimed for this system of steam heating over ordinary ones are :

1. That it is as well adapted to mild weather as cold, whereas with a steam heating system a temperature of 212 degrees must be attained to secure any effect from the radiators.

2. That considerable saving in fuel may be effected in mild weather, due to the circulation of steam below atmospheric pressure, thus avoiding overheating, so common with low pressure steam heating. In many sections in the northern part of this country the average outside temperature during the heating season is 35 to 40 degrees above zero.

Steam heating systems based on 70 degrees in zero weather are difficult to control with an outside temperature of, say, 40 degrees, when the loss of heat from a building is only about three-sevenths that in zero weather. The difference in temperature between the steam or vapor and the air in the room need be, under the stated conditions, only three-sevenths as much as in zero weather.

3. The mercury seal vacuum system when applied to a steam heating apparatus secures a wide range in the temperature at which the radiators may be kept to provide for different weather conditions.

The lack of this range of temperature in the ordinary low pressure steam system is the greatest drawback to its successful use in house heating. It is said to be practicable to maintain temperatures varying all the way from 140 to 230 degrees or more, which would permit the system to meet practically any outside weather conditions.

The following table shows the temperatures corresponding to different pressures:

TABLE XXXVIII.

SHOWING STEAM PRESSURE AND VACUUM AND CORRESPONDING TEMPERATURE.			
In. of mercury.	Temperature.	Gauge pressure.	Temperature.
Vacuum gauge.	Fahr.	Lb. per sq. in.	Fahr.
28.....	101.4	0.304.....	213.0
26.....	125.6	1.3.....	216.3
24.....	147.9	2.3.....	219.4
22.....	152.3	3.3.....	222.4
20.....	161.5	4.3.....	225.2
18.....	169.4	5.3.....	227.9
16.....	176.0	6.3.....	230.5
14.....	182.1	7.3.....	233.0
12.....	187.5	8.3.....	235.4
10.....	192.4	9.3.....	237.8
5.....	203.1	10.3.....	240.0
0.....	212.1		

The pressures are not given in even pounds. The 1.3 pound gauge pressure corresponds to 15 pounds absolute pressure, and so on.

COMPARISON WITH HOT WATER HEATING.

Advantages claimed for this system over hot water heating are:

1. Saving in cost of installation, as the pipes may be made smaller and smaller radiators may be used, owing to the higher temperatures carried in cold weather.

2. The ability to increase or decrease the temperature in the radiators more quickly, owing to the much smaller volume of water in the system.

3. The absence of danger of drainage from leaks.

On the other hand, in weather, say, from 50 to 60 degrees, when it is only necessary to take the chill off a house, a hot water system is especially well adapted to fulfill the requirements, and the temperature of the water may be kept as low as desired, whereas with the mercury seal vacuum system 140 degrees F. is about as low a temperature as can be maintained, and then not for any length of time, owing to imperceptible air leaks, which destroy the vacuum.

The advantage of quick heating in the vacuum system is, in a measure, offset by the advantage possessed by hot water for storing the heat during the night, insuring a warm house in the morning. With the mercury seal system all radiators are kept at the same temperature. The steam supply may not be throttled without fear of water backing up in the radiators and causing noise. In hot water heating systems the temperature of each radiator may be controlled at will by throttling down the supply, thus giving individual control of the temperature of each room.

VACUUM AIR VALVES AND THE NORWALL SYSTEM.

Several patterns of vacuum air valves have been put on the market designed to permit the escape of air from radiators and to prevent its reentering them when the steam pressure falls. With a system perfectly tight at all valves, fittings, etc., and with all vacuum air valves in working order a steam plant may be run as a vacuum system. It can derive the advantage of a great range in the temperature of the radiators by simply raising the steam

pressure sufficiently to drive out all the air, for then when the pressure falls below that of the atmosphere the radiators will remain filled with steam at a minus pressure and at a temperature below the boiling point, viz., 212 degrees F.

Mr. George D. Hoffman writes of the Norwall system as follows:

“The difficulty heretofore existing of being able positively and

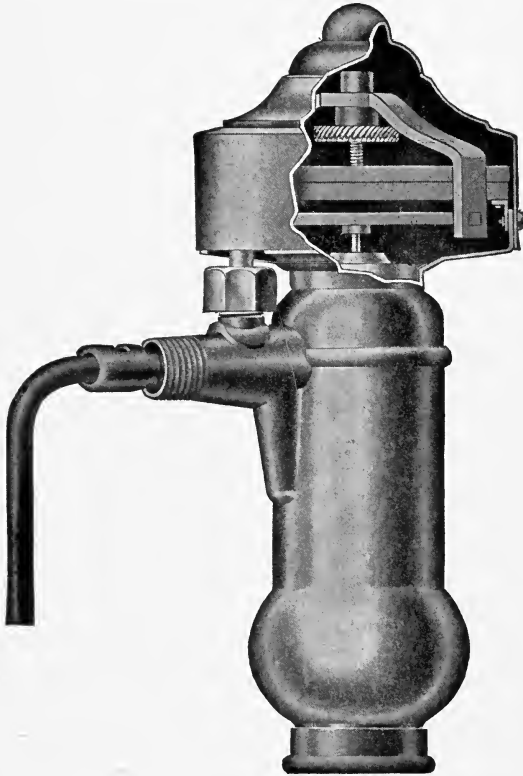

Fig. 52.—The Norwall Vacuum Air Valve.

automatically to prevent the air from going back into the system when the steam pressure is reduced below that of atmosphere, is overcome by the use of the Norwall automatic air and vacuum valve (See Fig. 52) and the Norwall air line system of vacuum heating.

“ The valve is intended to be a vacuum system in itself. With an apparatus that is practically air-tight in all its joints and connections, simply screw on the valves in place of the ordinary air valves and you have installed a complete system of vacuum steam heating. The use of the Norwall valve does not necessitate air lines or any mechanical appliance for exhausting the air. Pressure exhausts the air from the system through the valve, and then when pressure goes off the valve automatically closes, preventing the ingress of air into the apparatus through the valve. The valve is especially designed for use in connection with residence work, stores and small apartments where the number of radiators in connection with any one plant is limited.

“ The Norwall air line system of vacuum steam heating is especially designed for use on large buildings such as apartment buildings, schools, hospitals, asylums, business blocks, etc. In this system no automatic air valves are used on the radiators. Each radiator is fitted with a relief valve which is open at all times, and which is connected by a small pipe designated as an air line to a vacuum tank located in the basement adjacent to the boiler. All air from the entire system is vented by pressure into this tank and from the tank through a large air valve either into the basement, or it can be piped to a flue and thus vented directly to the atmosphere. The advantage with the air line system of vacuum steam heating in a building occupied by tenants is the fact that the apparatus is at all times in direct control of the engineer or fireman.” It is not wise to attempt to provide a vacuum system in large buildings by simply attaching vacuum air valves to the radiators, because of the great number of valve stuffing boxes, fittings, etc., at which an inleakage of air is liable to occur and destroy the vacuum, necessitating the raising of steam pressure at frequent intervals to force the air out of the system.

GORTON VAPOR VACUUM SYSTEM OF HEATING.

In the Gorton Vapor Vacuum System of Heating, by the use of an automatic drainage valve, which is placed on the return end of each radiator, and an automatic relief valve, which is connected to the steam and return mains in the cellar, it is claimed that steam can be circulated under a vacuum, and that the heat in any

radiator can be controlled by graduating the opening of the radiator valve.

In this system the hot-water type of radiator is usually employed, with the steam inlet at the top and the return outlet at

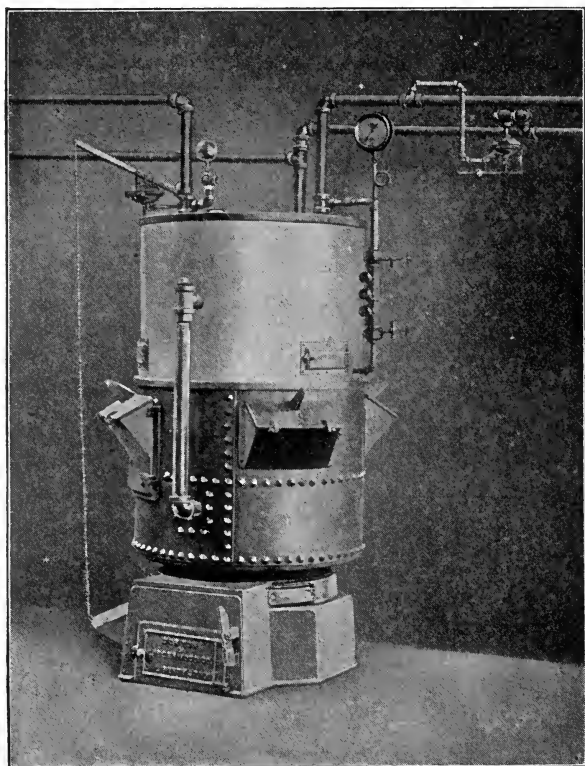

Fig. 53.—Gorton Vapor Vacuum System Connections.

the bottom. The system of piping is the ordinary two-pipe, gravity dry return, with a loop seal at the end of each steam main.

The automatic drainage valve is specially constructed, with a brass cylinder in the body of the valve, with a small opening in the side of the cylinder, which forms the valve seat. A cone-shaped piece of metal projects from the disk of the valve into the opening of the seat, which is made at such an angle as to prevent

wedging or sticking. The disk of the valve is suspended from the top of the cylinder, so that it can swing freely backward and forward, thus opening and closing the valve.

Normally the valve is closed, but a counterweight is applied in such a manner as to render the opening of the valve very gradual, according to the difference in pressure. Therefore, when a radiator valve is opened, the pressure of the steam in the radiator will force the cone backward, thus opening the valve and allowing the air in the radiator, and the water of condensation, to pass through, and down into the return main, where the air is removed through

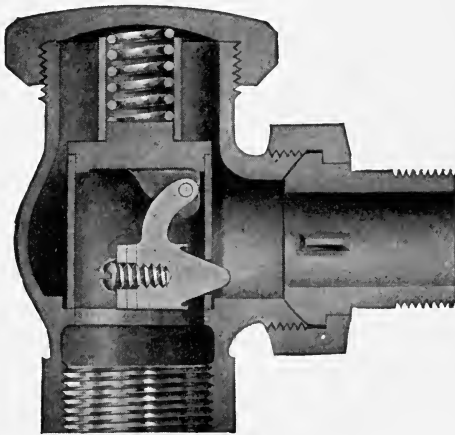

Fig. 54.—Gorton Vapor Vacuum System Valve.

the automatic relief valve, and the water returns to the boiler.

The automatic relief valve is made in two parts. The upper part, or air valve, is connected to the return main, and the lower part, or bowl, is connected to the steam main. In the bowl is a very sensitive flexible diaphragm, which is connected to the valve rod. The lower end of the rod is connected with a balance lever and weight, and the upper end of the rod terminates in the Jenkins disk valve seat of the air valve. The weight of the balance lever is so adjusted that the air valve will open when the pressure in the return main equals that in the steam main.

The system can be run as a vacuum system by simply raising enough pressure of steam to expel the air from all of the radiators,

and then allowing the fire to cool until the desired amount of vacuum is obtained, after which a low fire should be maintained.

BROOMELL'S VAPOR SYSTEM OF HEATING.

The vapor system is a modified two-pipe system of steam heating, arranged with devices to prevent more than a few ounces pressure accumulating in the boiler or radiators. Each radiator is equipped with a special supply valve shown in Fig. 56, designed

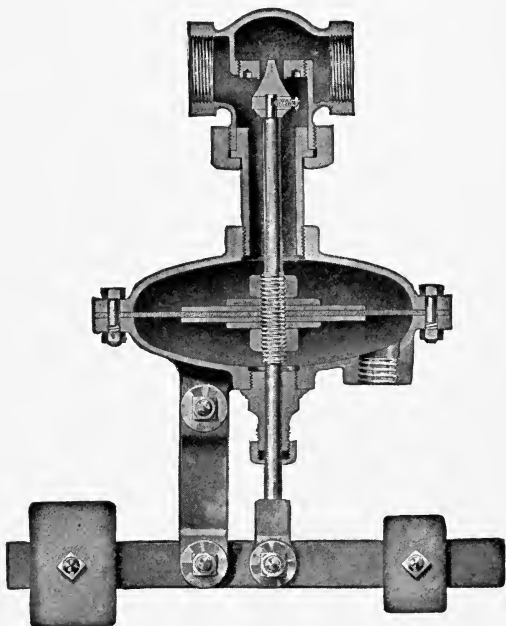

Fig. 55.—Gorton Vapor Vacuum System Differential Controller.

to admit a volume of vapor or low pressure steam sufficient to supply a portion or all of the radiating surface. At the return end of each radiator is placed a small combined water seal and air vent (see Fig. 57), designed to permit the escape of air and the water condensed in the radiator. Fig. 58 shows a radiator equipped with the supply valve and the combined water seal and air vent. Radiators of the hot water type are invariably used in connection with this system.

The returns from the radiators, this being a two-pipe system,

are combined in the basement and lead to a receiver (see Fig. 59) connected with the boiler. The main return is sealed at the end, as illustrated in Fig. 60, to prevent the escape of vapor to the cellar. From the chamber C the air combined with some vapor from

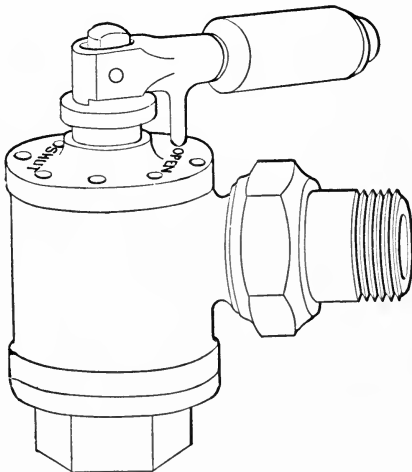

Fig. 56.—Vapor System Supply Valve.

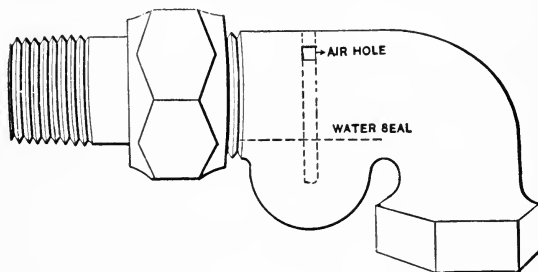

Fig. 57.—Union Elbow for Return End of Radiator.

the system escapes through the air line to the condensing radiators suspended from the basement ceiling as shown in Fig. 59. The vapor is condensed in these radiators and flows back by gravity to the boiler, the air escaping to the smoke flue. The latter is preferable to any other point of escape since the heat in the flue causes a slight pull on the air line accelerating the removal of the air from the system.

The receiver is open at the top, and there is no check valve between it and the boiler. It, therefore, acts as a perfect safety valve to prevent any excess of pressure in the boiler. Should the boiler pressure increase, the water would be driven out into the receiver. The float therein would be raised and the drafts closed. Should the pressure continue to increase from any cause

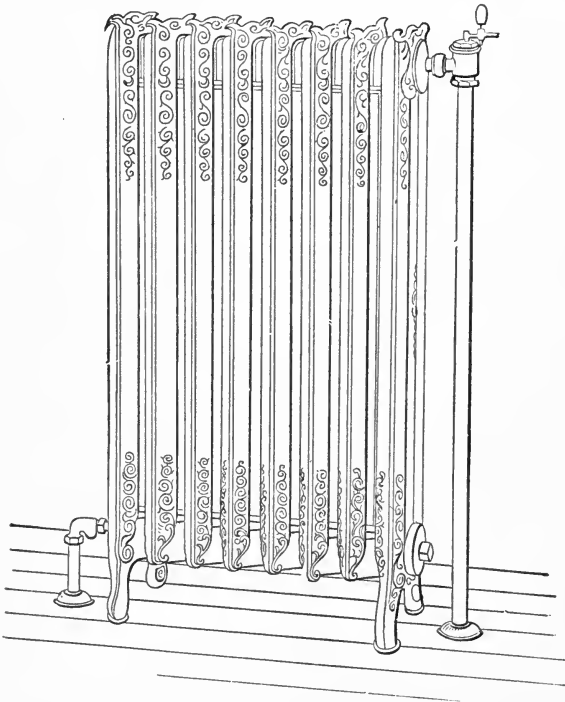

Fig. 58.—Radiator Connected on Vapor System.

the float in the receiver would rise until the lever of the relief valve is raised, permitting the escape of steam and reducing the pressure. A glass water gauge is attached to the receiver, and a scale indicates the boiler pressure in ounces. No other pressure gauge is necessary.

The maximum pressure never exceeds 13 ounces, and therefore the size of the radiators must be based on relatively low temperatures, and an amount of surface within 10 or 15 per cent. of that

required with hot water heating is commonly provided to warm the rooms properly in the coldest weather. With this system one cannot overcome the effect of a shortage in radiating surface by increasing the pressure and temperature as in low pressure steam

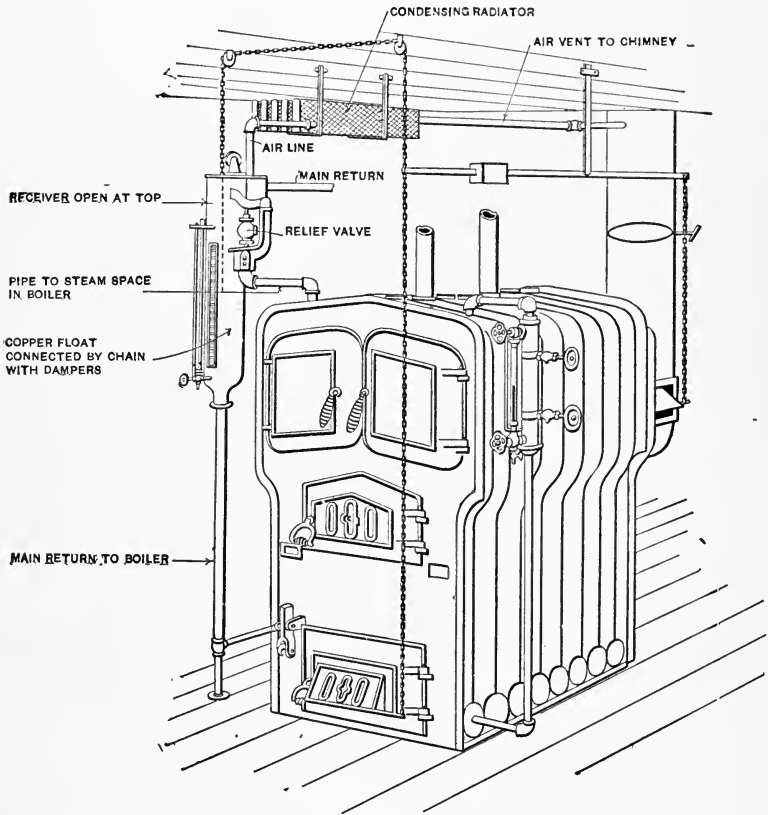

Fig. 59.—Connections at Boiler, Showing Condensing Coil.

heating, since the water would be backed out of the boiler through the main return connected with the receiver.

The water line of the boiler should be at least 4 feet below the basement ceiling to give sufficient pitch to the pipes and to provide ample height to cause the water to flow back into the boiler. A common arrangement of piping is shown in Fig. 61.

The returns must be run overhead in the basement, that is, they must be "dry." These pipes are preferably left uncovered in order to promote the condensation of any vapor escaping to them from the radiators.

The vapor system may be used in connection with exhaust steam plants supplemented by live steam and with central heating plants, as shown in Fig. 62. When the condensation is not returned to the boilers the pump and receiver are omitted, and the condensation is discharged to the sewer through a cooling coil. Central station heating companies commonly require the cooling

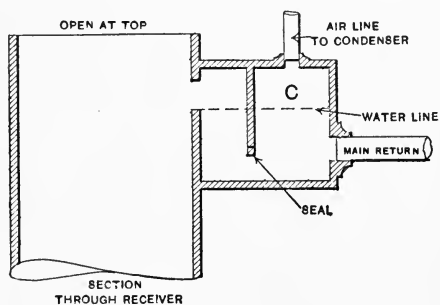

Fig. 60.—Seal at End of Main Return.

coil on low pressure systems to contain one-fifth to one-sixth of the entire direct radiating surface in the building.

ADVANTAGES CLAIMED FOR THE VAPOR SYSTEM.

1. The control of the heat given off by each radiator independently by means of the quintuple valve shown in Fig. 56, which may be set to admit any desired amount of steam. This is of great value when there is but one radiator in a room, for with ordinary steam heating one has practically no control of the room temperature under these conditions.

2. Freedom from any danger of over-pressure on the boiler. The safety valve of an ordinary system may stick or the water in the expansion pipe of a hot water system may become frozen.

3. Economy in fuel because of the easy control of temperature afforded, thus avoiding overheating.

4. Much smaller pipes may be used than with low pressure

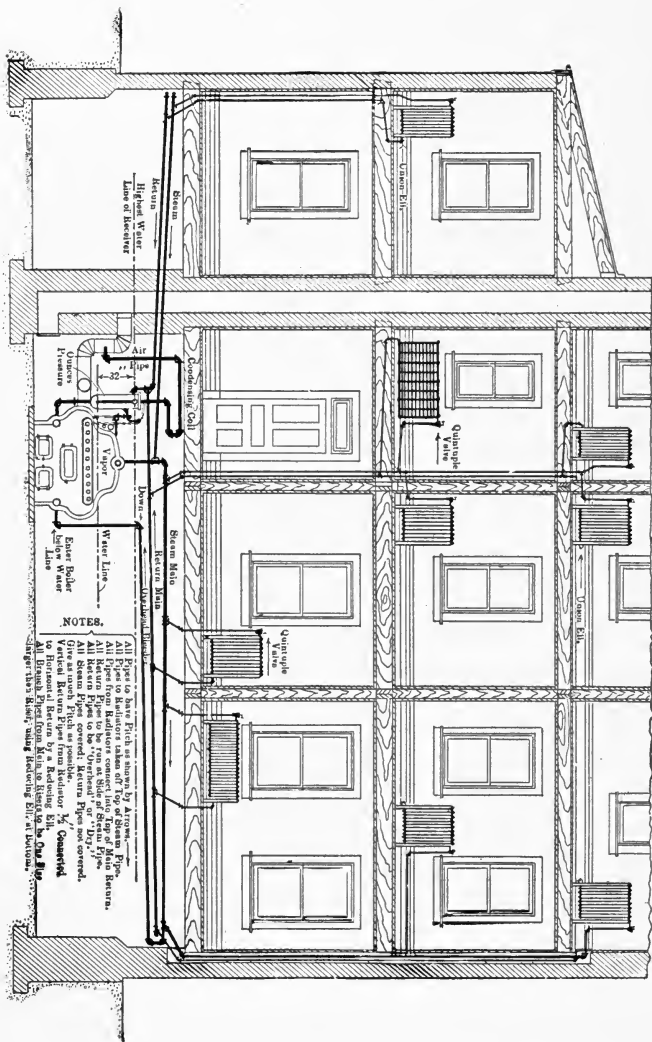

Fig. 61.—The Vapor System, Showing Manner of Running Steam and Return Pipes.

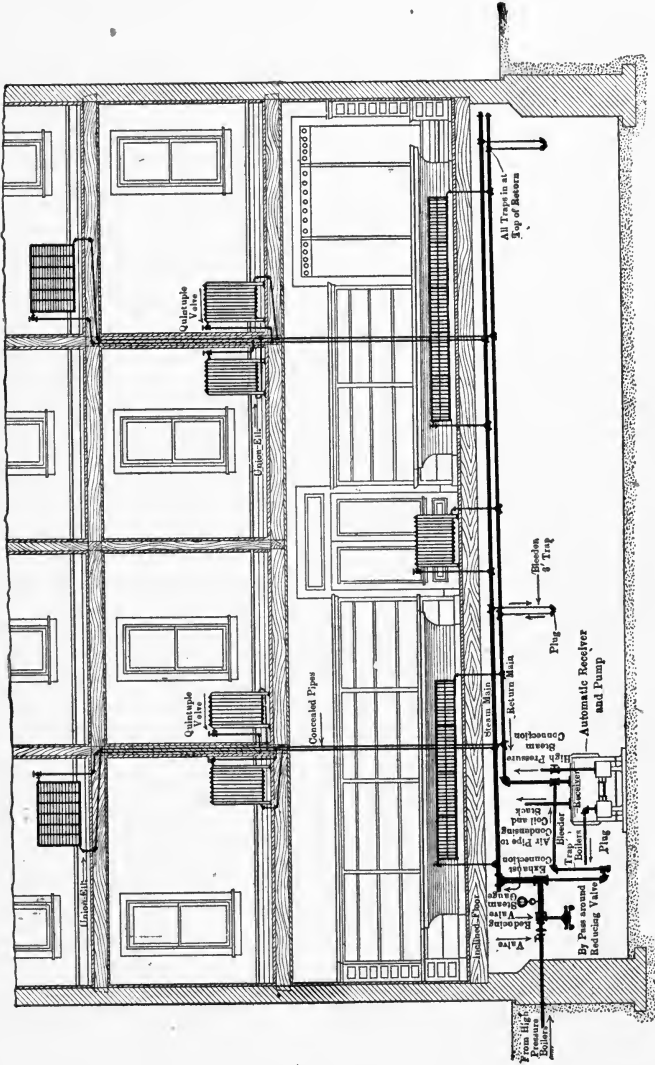

Fig. 62.—The Vapor System, Showing Manner of Heating from High Pressure Boilers.

steam or hot water heating. With the vapor system the supply connections practically never exceed $\frac{3}{4}$ inch in size, and the returns $\frac{1}{2}$ inch for direct radiators.

5. Air valves are not required, the air being removed through the small vent in the special fitting attached to the return end of each radiator.

6. Quick heating ability. A vapor may be very quickly secured sufficient to fill the radiators without forcing the fire.

INDEX.

Air, Weight of, per cubic foot.....	34
“ Capacity of, to absorb moisture.....	34
“ Heat brought in by.....	43
“ Temperature of, at inlet.....	45
“ Specific heat of.....	46
Aspirating coils.....	48
Babcock's formula for flow of steam in pipes.....	81
Back pressure, Effect of.....	105
“ “ Counteracting by increased boiler pressure.....	106
Blower coils, Heat given off by.....	44
“ “ See Heaters.	
“ “ How compute size of.....	45
“ “ Size of required.....	65-66
Boiler connections, Sizes of.....	103
Boilers, Efficiency of.....	8-9
“ Proportion of heating to grate surface.....	11-23
“ Horse power required to heat given space.....	63-66
“ Capacities of	23
“ How compute size of.....	23
Boiler Horse Power, expressed in heat units.....	8
“ ratings	24
Briggs' formula for steam pipes.....	95
British Thermal Unit (B. T. U.), or Heat Unit, Definition of.....	7
Broomell System, Description of.....	146 to 153
Charts for computing steam radiating surface required.....	57-59
“ Hot water	61-62
Child, E. T., Article by, on Steam Mains.....	94 to —
Coal, Heating power of.....	8
Coke, “ “ “	8
Coils, Heat given off by.....	37, 39, 40
“ Aspirating	48
“ for heating water, Efficiency of.....	68-69
Combination heaters, Tests on.....	11
“ “ Types of	11-12-13-14-15
“ “ Capacity of	16
Combustion, Rate of in boilers.....	10, 23, 24
Condensation of steam, Effect of, in pipes.....	85
D'Arcy's formula for flow of steam in pipes.....	81
Donnelly system, Description of.....	127-128
Efficiency of boilers.....	9
Evaporation, Heat required for.....	9
“ “ required to effect same.....	34

K-M-C- System, Description of.....	134 to 137
Liquids, Boiling of, in vats.....	70
Mains, Hot water, Capacities of, for direct heating.....	110-111
" " " For direct heating, various authorities.....	112
" " " " indirect heating.....	112-113
" Sizes of, for low pressure steam heating.....	88-99-100
" Steam, Velocities in.....	100-101
" Circuit, Capacity of.....	102
" Returns, Sizes of.....	92
" " " " for two pipe vacuum systems.....	93
" Sizes of, for steam heating.....	88-89
" " " vacuum system.....	92-93
" Chart and table showing capacities of, according to different rules.....	97-98
M'Gonagle System, Description of.....	131 to 134
Mechanical equivalent of heat.....	33
Morgan System, Description of.....	134 to 137
Norwall System and air valves—Description of.....	141 to 143
Paul System, Description of.....	123 to 126
Persons, Heat given off by.....	8
Petroleum, Heating power of.....	8
Pipes, Capacities of, for hot water heating.....	110-111
" Resistance in, to flow of water.....	110
Pipes. See Risers.	
Pipe sizes:	
Briggs' formula.....	95
Tudor's ".....	95
Baldwin's rule.....	95
Wolff's ".....	95-96
Pipes, see Mains.	
" Capacities of, expressed in amount of radiation supplied.....	88
" Exhaust for Engines.....	104
" Steam.....	104
" Flow of steam in.....	81-82
" " " " Example, illustrating use of tables.....	85
" " " " with more than 40% drop in pressure.....	86
" Heat given off by.....	40
" Relative capacities of.....	86
" Equation of (Table).....	87
Radiation, see Radiators.	
" Indirect steam, How compute amount required.....	41
" Indirect; Temperature at Inlet.....	45
" Relation between direct and indirect.....	43
" How compute on a heat unit basis.....	54-55-56
" Hot Water, How Compute by Charts.....	61 to 63
" Direct steam, How compute by charts.....	57 to 60

Electrical heat units.....	8
Electric heaters	18-19-20
" heating, Cost of.....	21
" " Combined efficiency of apparatus required.....	22
Elbows and bends.....	84
" " " Resistance of	96-115
Electricity, Heating power of.....	8
Engines, Steam and exhaust pipe sizes.....	103-104
" Condensing, Steam heating in connection with.....	106
Expansion tanks, Capacity of.....	116
Factors for use in computing pipe sizes.....	83-84
Feed water heaters, Proportion of.....	68
Flue area, Relation between flue area and indirect surface.....	42-43
Flues, Velocities in.....	28, 50
Fuels, Heating power of.....	8
Fuel, Amount of per season.....	25
Furnaces, Proportions of heating to grate surface.....	11
" Rate of combustion in.....	27
" Tests of	27-28-29-30
Furnace Heating, Temperature of air supply.....	28
" " Velocity of air in pipes.....	28-29-30
Gas, Heating power of.....	8-17
" heaters	79
Glass Surface, Equivalent.....	45
" Loss of heat through.....	56
Gorton System, Description of.....	143 to 146
Heat, Loss of, from rooms.....	21
" " " by transmission through walls, glass, etc.....	53-54
" How compute loss of.....	54-55
" Relative loss of, from buildings of different forms.....	65-67
" unit, Definition of.....	7
Heaters combined with fans.....	44-45, 66-67-99
" Supplementary	44-45
" Aspirating	48
Heating Surface, Ratio of, to grate.....	10-11
Horse power of boiler in heat units.....	8
Hot Water Heating.....	108 to 116
" " See Water.	
Hot water combination heaters, Tests on.....	11
" " " " Types of	11-12-13-14-15
" " " " Capacity of.....	16
" " generators	69-70
" " Heaters for water supply.....	75-76-77-80
Humidity	34-35
Ice, Heat units absorbed in melting.....	32

Kerosene, Heating power of.....	8
“ for heating	17-18
Radiator Connections, Sizes of, for Hot Water.....	113
Radiators, Hot water, Indirect, Pipe sizes for.....	112-113
“ Direct steam, Heat given off by.....	36-37-38-39-40, 94
“ Indirect steam, Heat given off by.....	41
“ “ “ “ “ “ “ when used with fans... ..	99
“ Direct, Heat given off by, in rooms at different temperatures	40
Refrigeration	33
Returns, Steam heating, Sizes of.....	92
Risers, Steam, Velocities in.....	91-102
“ Hot water, Capacities of.....	113-114
“ Steam, Capacities of.....	89-90
“ “ One pipe	91
“ “ Two pipe	92
Specific heat	31
“ “ of air	31-46
Steam Heating in connection with Condensing Engines.....	106-107
“ pressure and vacuum and corresponding temperature, Table showing	140
Steam, flow of in pipes.....	81 to 86
“ “ “ with more than 40% drop in pressure.....	86
Swimming pools, Heating of.....	71-72-73-74-75
“ “ How compute boiler capacity required.....	73-74
“ “ How compute heating surface required.....	74
Tables. See list of tables in Table of Contents.....	
Tanks, Expansion, capacities of.....	116
Tank heaters, Capacity of.....	75-76-77
“ “ Efficiency of	80
Thermograde System, Description of.....	128 to 131
Trane System, Description of.....	137 to 141
Tudor formula for steam pipes.....	95
Vacuum System, Pipe sizes.....	92-93
Vapor System, Description of.....	146 to 153
Ventilation, Loss of heat by.....	41-46
Water, Flow of, in pipes.....	108
“ Heating of, by steam pipes.....	68
“ Volume of, to supply radiators.....	109
“ Weight of distilled.....	110
“ Velocity of, in heating pipes.....	110
“ How compute surface required for heating.....	68
“ backs, Proportions and capacity of.....	77-78-79
Webster system, Pipe sizes.....	92-93
“ “ Description of	117 to 122
Wood, Heating power of.....	8

ILLUSTRATIONS.

<i>Figure.</i>		<i>Page.</i>
1.....	Horizontal Tubular Boiler.....	8
2.....	Water Tube Boiler.....	9
3.....	Sectional Cast Iron Boiler with Vertical Sections.....	10
4.....	Sectional Cast Iron Boiler with Horizontal Sections.....	11
5.....	Dome Water Heater.....	12
6.....	Ring Water Heater.....	12
7.....	Combined Ring and Dome Heater.....	13
8.....	Deep Ring Water Heater.....	13
9.....	Pipe Coil Water Heater.....	14
10.....	Auxiliary Heater for Combination Heating.....	14
11.....	Types of Dome Heater for Combination Heating.....	15
12.....	Disk Heater for Combination Heating.....	15
13.....	Overhanging Type of Auxiliary Heater.....	15
14.....	Maltese Type of Auxiliary Heater.....	16
15.....	Type of Electric Radiator.....	18
15A.....	Luminous Electric Radiator.....	19
15B.....	Non-Luminous Electric Radiator.....	20
16.....	Plan, and Front and Side Elevations, Concealed Radiator.....	36
17.....	Indirect Radiator Connections.....	42
18.....	Blower System Heater.....	43
19.....	A Heater for Blower Use.....	44
20.....	Supplementary Heater or Reheater.....	45
21.....	Fan Blowing Air Through Heater.....	46
22.....	Fan or Blower Drawing Air Through Heater.....	46
23.....	Section Through Vent Flue Showing Aspirating Coil.....	47
24.....	Elevation of Aspirating Heater on Line A-B.....	47
25.....	Plan of Ducts Connected with an Aspirating Heater.....	49
26.....	Elevation of System on Line AB of Fig. 25.....	51
26A.....	Variation in Exposure in Buildings of Equal Cubic Contents	65
27.....	Hot Water Storage Tank Heated by Steam.....	69
28.....	Arrangement of Heater Connected with Swimming Pool.....	72
29.....	Tank Heater Connections.....	76
30.....	Gas Heater Connected with Range Boiler.....	78
31 and 32.....	Methods of Dripping Risers.....	90
33.....	Head of Water Causing Flow.....	108
34.....	Webster Water Seal Motor.....	118
35.....	Webster Water Seal Motor.....	119
36.....	Typical Radiator Connections.....	120
37.....	Typical Arrangement of Vacuum Pump and Feed Water Heater in Webster Vacuum Heating System.....	121
38.....	Front Elevation of Paul Exhausting Apparatus.....	123
39.....	Paul System Connections for One-Pipe System.....	124
40.....	Paul System Connections for Two-Pipe System.....	124
41.....	Differential Pressure Controlling Valve.....	127

<i>Figure.</i>		<i>Page.</i>
42.....	Impulse Automatic Valve.....	127
43.....	Application of the Donnelly System to Radiating Coils...	128
44.....	Thermograde Control Valve.....	129
45.....	Radiator Equipped with Thermograde Valves.....	130
46.....	Typical Arrangement of the McGonagle Vacuum Heating System	132
47.....	Mercury Seal	134
48.....	Application of Morgan System to One-Pipe Steam Radiation	135
49.....	The K. M. C. Manual Retarder.....	136
50.....	Trane System Air Valve.....	138
51.....	Trane One-Pipe Vacuum System.....	139
52.....	The Norwall Vacuum Air Valve.....	142
53.....	Gorton Vapor Vacuum System Connections	144
54.....	Gorton Vapor Vacuum System Valve	145
55.....	Gorton Vapor Vacuum System Differential Controller...	146
56.....	Vapor System Supply Valve.....	147
57.....	Union Elbow for Return End of Vapor Radiator.....	147
58.....	Radiator Connected on Vapor System.....	148
59.....	Connections at Boiler Showing Condensing Coil.....	149
60.....	Seal at End of Main Return.....	150
61.....	The Vapor System, Showing Manner of Running Steam and Return Pipes.....	151
62.....	The Vapor System, Showing Manner of Heating from High Pressure Boilers.....	152

CHARTS.

<i>Chart.</i>		<i>Page.</i>
1.....	Ratios for Direct Steam Radiating Surface to Rooms with Two Sides Exposed Toward North and West, with Glass Surface Aggregating 25 per cent. of Total Exposure	57
2.....	Ratios for Direct Steam Radiating Surface in Rooms Having Only One Side Exposed Toward North or West, with Glass Surface Aggregating 20 per cent. of Total Exposure	59
3.....	Ratios for Direct Hot Water Radiating Surface Open Tank System in Rooms with Two Sides Exposed Toward the North and West, with Glass Surface Aggregating 20 per cent. of Total Exposure.....	61
4.....	Ratios for Direct Hot Water Heating Surface, Open Tank System, in Rooms with Only One Side Exposed Toward the North or West, with Glass Surface Aggregating 20 per cent. of Total Exposure.....	62
5.....	Cubic Contents, Showing Space Heated per Boiler Horse Power in Isolated Buildings Under Conditions Stated	63

<i>Chart.</i>	<i>Page.</i>
6.....	Cubic Contents, Showing Boiler Horse Power for Isolated Building Under Conditions Stated..... 66
6A.....	Size of Steam Main, According to Different Rules..... 97

TABLES.

<i>Table.</i>	<i>Page.</i>
I.	Ratings of Combination Heaters..... 16
II.	Anemometer Tests—Furnace Heating..... 28
III.	Flue Velocities—Furnace Heating..... 30
IV.	Weight of Air, per Cubic Foot..... 32
V.	Weight of Water Vapor, per Cubic Foot..... 34
VI.	Steam Radiator Tests..... 39
VII.	Loss of Heat From Pipes..... 40
VIII.	Heat Given Off by Indirect Radiators..... 41
IX.	Flue Velocities 50
X.	Loss of Heat Through Brick Walls 53
XI.	Loss of Heat Through Stone Walls..... 53
XII.	Loss of Heat Through Pine Planks 53
XIII.	Loss of Heat Through Glass, Etc..... 54
XIV.	Loss of Heat Through Partitions, Floors, and Ceilings... 54
XV.	Factors for Exposure, Etc..... 54
XVI.	Flow of Steam in Pipes..... 82
XVII.	Factors for Different Pressures 82
XVIII.	Factors for Different Drops in Pressure..... 83
XIX.	Factors for Different Lengths 83
XX.	Resistance at Entrance to Pipes..... 84
XXI.	Equation of Pipes..... 87
XXII.	Capacities of Steam Pipes, Expressed in Direct Radiating Surface 88
XXIII.	Capacities, Up-Feed, One-Pipe Steam Risers 91
XXIV.	Capacities, Up-Feed, Two-Pipe Steam Risers..... 92
XXV.	Capacities of Returns Two-Pipe Vacuum Systems..... 93
XXVI.	Capacities, Steam Mains..... 98
XXVII.	Sizes of Main Pipes for Boilers..... 103
XVIII.	Sizes of Supply Pipes for Engine..... 104
XXIX.	Sizes of Exhaust Pipes for Engine..... 104
XXX.	Volume and Weight of Distilled Water..... 110
XXXI.	Capacities of Hot Water Mains (by the author)..... 111
XXXII.	Capacities of Hot Water Mains (various authorities).... 112
XXXIII.	Capacities of Hot Water Pipes for Indirect Radiation... 113
XXXIV.	Comparison of Ratings for Hot Water Risers..... 113
XXXV.	Capacities of Hot Water Risers (by the author)..... 114
XXXVI.	Capacity of Expansion Tanks..... 116
XXXVII.	Pipe Sizes, Thermograde System..... 131
XXXVIII.	Temperatures Corresponding to Different Steam Pressures 140



**THIS BOOK IS DUE ON THE LAST DATE
STAMPED BELOW**

**AN INITIAL FINE OF 25 CENTS
WILL BE ASSESSED FOR FAILURE TO RETURN
THIS BOOK ON THE DATE DUE. THE PENALTY
WILL INCREASE TO 50 CENTS ON THE FOURTH
DAY AND TO \$1.00 ON THE SEVENTH DAY
OVERDUE.**

OCT 26 1932

20 Jan '64 CG

REC'D LD

JAN 6 '64-12 M

LD 21-50m-8, 32

Feb 6



161903

Snow
TH7461
S7

